

*Crown Copyright Reserved*

P W-B 3

# Post Office Engineering Department

---

## TECHNICAL PAMPHLETS FOR WORKMEN

---

*Subject :*

### Wheatstone System Morse Keyboard Perforators

ENGINEER-IN-CHIEF'S OFFICE  
1919

*(Reprinted July, 1925, incorporating amendments issued to date.)*

- ( " Jan., 1929, " " " " )
- ( " May, 1930, " " " " )
- ( " Mar., 1932, " " " " )
- ( " Apr., 1934, " " " " )
- ( " Nov., 1934, " " " " )

# LIST OF Technical Pamphlets for Workmen

## GROUP A.

1. Magnetism and Electricity.
2. Primary Batteries.
3. Technical Terms.
4. Test Boards.
5. Protective Fittings.
6. Measuring and Testing Instruments.
7. Sensitivity of Apparatus.
8. Standard List of Terms and Definitions used in Telegraphy and Telephony. (*Not on Sale.*)
9. Standard Graphical Symbols for Telegraphy, Telephony and Radio Communication. (*Not on Sale.*)

## GROUP B.

1. Elementary Principles of Telegraphy and Systems up to Morse Duplex.
2. Telegraph Concentrators.
3. Wheatstone System. Morse Keyboard Perforators.
4. Quadruplex, Quadruplex Repeated Circuits and Telegraph Repeaters, Simplex and Duplex.
5. Hughes Type-printing Telegraph.
6. Baudot Multiplex Type-printing System.
7. Western Electric Duplex Multiplex. Murray Duplex Multiplex. Siemens and Halske Automatic Type-printing System.
8. Fire Alarm Systems.

## GROUP C.

1. Wireless Transmission and Reception.
2. Interference with Reception of Broadcasting.

## GROUP D.

1. Elementary Principles of Telephony.
2. Telephone Transmission. "Loading." Telephone Repeaters and Thermionic Valves.
3. Principles of Telephone Exchange Signalling.
4. Magneto Exchanges—Non-Multiple Type.
5. Magneto Exchanges—Multiple Type.
6. C.B.S. No. 1 Exchanges—Non-Multiple Type.
7. C.B.S. Exchanges—Multiple Type.
8. C.B. Exchanges—No. 9 Type.
9. C.B. Exchanges—No. 10 Type.
10. C.B. Exchanges—No. 12 Type.
11. C.B. Exchanges—22 Volts.
12. C.B. Exchanges—40 Volts.
13. Trunk Telephone Exchanges.
14. Maintenance of Manual Telephone Exchanges.
15. Telephone Testing Equipment.
16. Routine Testing for Manual Telephone Exchanges.
17. Internal Cabling and Wiring.
18. Distribution Cases, M.D.F. and I.D.F.
19. Cord Repairs.

[Continued on page iii of Cover.]

**CORRECTION SLIP TABLE**

The month and year of issue is printed at the end of each amendment in the Correction Slips, and the number of the slip in which any particular amendment is issued can, therefore, be traced from the date. In the case of short corrections made in manuscript, the date of issue of the slip should be noted against the correction.

The Summary portions of the Correction Slips should be completed and affixed below in numerical order.

---

## **CORRECTION SLIP TABLE—(cont.)**

---

The month and year of issue is printed at the end of each amendment in the Correction Slips, and the number of the slip in which any particular amendment is issued can, therefore, be traced from the date. In the case of short corrections made in manuscript, the date of issue of the slip should be noted against the correction.

The Summary portions of the Correction Slips should be completed and affixed below in numerical order.

---

Wheatstone System.  
Morse Keyboard Perforators.

(B.3.)

---

*The following pamphlets in this series are of  
kindred interest :*

- B.1. Elementary Principles of Telegraphy.
- B.4. Quadruplex. Telegraph Repeaters.

# WHEATSTONE SYSTEM. MORSE KEYBOARD PERFORATORS.

---

---

## TABLE OF CONTENTS

	Page
1. Wheatstone Automatic System ... ..	3
(a) The Perforator ... ..	3
(b) The Transmitter ... ..	5
(c) The Receiver ... ..	9
2. The Gell Keyboard Perforator ... ..	13
3. The Kleinschmidt Keyboard Perforator ... ..	16
4. Wheatstone Automatic Simplex Circuits ... ..	17
5. Wheatstone Automatic Duplex Circuits ... ..	19
6. The Creed Wheatstone System ... ..	25
7. Method of Testing Speed ... ..	33

# WHEATSTONE SYSTEM. MORSE KEY-BOARD PERFORATORS.

## 1. THE WHEATSTONE AUTOMATIC SYSTEM.

At an early stage in the development of telegraphic science, it was recognized that circuits could not be worked to the fullest extent by direct manual operation. Mechanical means were, therefore, sought whereby the speed of transmission could be increased. One of the most effective methods devised for the purpose was Sir Charles Wheatstone's fast speed automatic system, which now finds its chief use in the distribution of press telegrams to all parts of the country.

In addition to the ordinary key-worded Morse apparatus which is used for speaking purposes, the equipment of a Wheatstone set involves the provision of three special instruments, viz.—

- (a) A perforator, by means of which holes representing the Morse code are punched in a slip of paper.
- (b) A transmitter, which sends out marking and spacing currents to line in accordance with the holes punched in the paper.
- (c) A receiver, which prints the Morse dot and dash signals on a paper ribbon.

### (a) THE PERFORATOR.

The form of perforator illustrated in Fig. 1 is wholly mechanical in its action.

The plungers A, A1, and A2, when struck by the rubber tipped mallets shown at the sides, operate the steel punches in a given order and produce combinations of holes in the paper, which correspond to the dots and dashes of the Morse code.

On striking the key A, the cutting faces of punches 1, 2, and 3 are forced through the paper into the holes similarly numbered on the front plate of the punch block (Fig. 2). The paper slip is, therefore, pierced with three holes in a vertical line. This represents a dot in the Morse code.

The operation of key A1 actuates punch 2 only, and produces one centre hole, which signifies a space.

The depression of key A2 causes punches 1, 2, 4 and 5 to perforate the dash signal.

The centre holes made by punches 2 and 4 act as a rack by which the paper is propelled through the perforator and also through the transmitter by the intervention of star wheels.

The perforations above the centre line represent marking currents, the duration being determined by the position of the succeeding hole below the centre line, which sends a spacing



Fig. 1.

current when the slip is passed through the transmitter. The centre holes in the slip are spaced at intervals of  $1/10$  inch centre to centre. If a length of slip containing 121 spacing perforations (which number may be obtained when the word "telegraph" is punched three times, the double space between the words, but no space after the last word being included), then the distance between the centres of the first and last holes should be exactly one foot.



**Keyboard Perforators.**—With the object of reducing the number of separate actions necessary to produce the perforations which go to make up Morse symbols by the method described, and of increasing the rapidity and ease of operating, perforators with typewriter keyboards have been introduced.

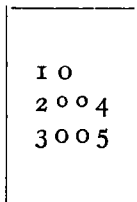

Fig. 2.

By the depression of a single key, the appropriate set of punches representing a complete letter or figure is selected and forced through the paper.

The keyboard perforators in general use for Wheatstone purposes are the Gell and the Kleinschmidt instruments, particulars of which are contained in sections 2 and 3.

#### (b) THE WHEATSTONE TRANSMITTER.

The positive pole of the battery (Fig. 3) is connected to *Cd*, *Cu*, and the negative pole to *Zd*, *Zu*; between these contacts the compound lever, *DU*, oscillates. The compound lever is in two parts, insulated from each other. *D* is connected to "down line or earth," and *U* to "up line or earth." When *D* makes contact with *Zd*, *U* is in contact with *Cu*, and when *D* moves to *Cd*, *U* goes over to *Zu*. In this way positive and negative currents are alternately sent to line.

A jockey wheel, *J*, presses against the upper end and holds the compound lever firmly against the contacts, preventing it remaining in the intermediate position shown in the figure. In one pattern of Wheatstone transmitter, the function of the jockey wheel is performed by a permanent magnet.

The bell-crank levers *A*, *A1* are the means by which the required movements of the compound lever are effected through rods *H*, *H1* and collets *K* and *K1*. The rocking beam *Y*, which is movable on a central pivot, has two projecting pins *P* and *P1*, against which the bell-crank levers are normally maintained by the action of springs *S3* and *S4*.

The rods *S*, *M* are placed one on each side of a star-wheel *W*, which is kept in motion by the mechanism while the transmitter is in action. The starwheel is so geared that the upward movement of the rods *S*, *M*, if properly adjusted,



rocking beam depresses P1 and allows P and S to rise, thus bringing the top of the compound lever to the left and reversing the current to line.

If slip, perforated (say) with the letter  $\begin{matrix} \circ & \circ \\ \circ & \circ \\ \circ & \circ \end{matrix}$  (A) be inserted, then when rod M rises it will be free to pass through the first upper hole, and the lever DU will be moved and will send a "marking" current; when the reverse movement of the rocking beam Y takes place, rod S will be free to pass through the first lower hole, and the current sent by DU will be reversed: a *dot* will, therefore, have been sent. On the next movement of the rocking beam, M will be free to pass through the second upper hole, and the length of the "spacing" current is consequently precisely equal to that of the previous "marking" current (*dot*). The "marking" current being now on, when the rocking beam leaves S free to rise, it is prevented from so doing by the paper, which is not perforated below the second upper hole. In this case, therefore, the "marking" current is kept on until the rod S is again free to rise, which it can do through the second lower hole, and the current is then reversed. It will be seen that the "marking" current is, therefore, kept on during movements equal to two dots and the space between, and this is the recognized length of a dash. It is thus clear that when properly perforated slip is run through the transmitter, any required Morse signals—dots and dashes, appropriately spaced—can be automatically sent to the Line.

The perforated slip is kept in position by a roller which gears with the starwheel. The position of the roller is limited

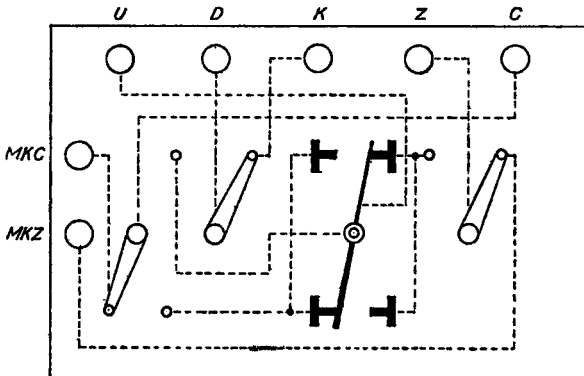

Fig. 4.—SWITCH CONNEXIONS OF WHEATSTONE TRANSMITTER.

so that it does not press upon the paper, but only prevents it from rising. The central portion of the roller is toothed, but on each side of the teeth space is provided to allow of the free upward movement of the rods S and M.

Fig. 4 shows the arrangement of the coupled switches which serve to transfer the electrical connexions from automatic to key working. In the position shown, the main battery terminals C, Z, are cross-connected to MKC, MKZ, which are externally joined to the battery terminals of the Morse key. The transmitter is, therefore, not in use.

At terminal offices worked on the universal battery

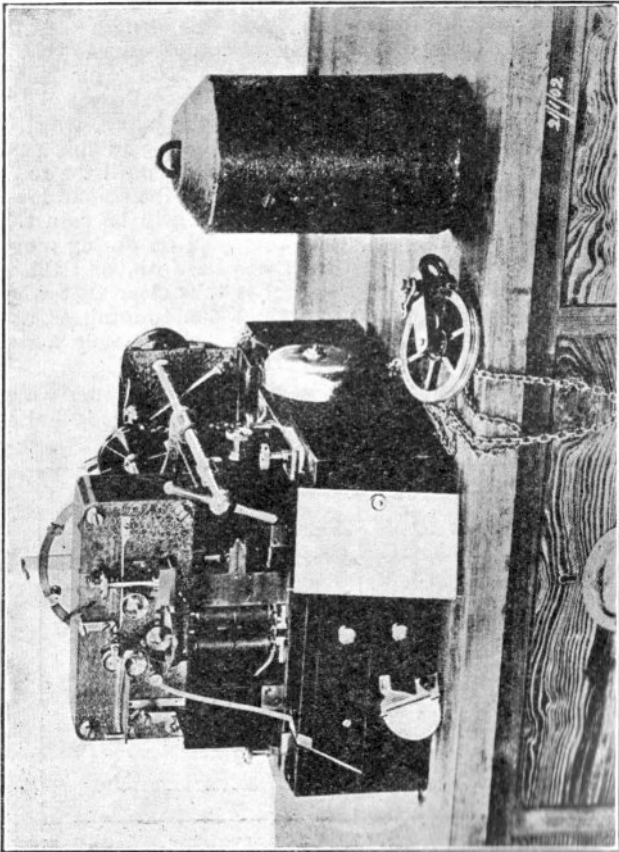

Fig. 5.—WHEATSTONE RECEIVER (SHOWING COILS).

principle, the transmitter terminal U is left disconnected. This avoids the necessity of continuing the former practice of opening out the contacts between which the upper part of the compound lever works.

(c) THE WHEATSTONE RECEIVER.

The Wheatstone Receiver is somewhat similar to a standard relay so far as the electrical portion of the apparatus is concerned.

The electro-magnets, which will be described later, are exposed to view in Fig. 5.

The arrangement of the permanent magnet, soft-iron armatures and inking disc is shown in Fig. 6.

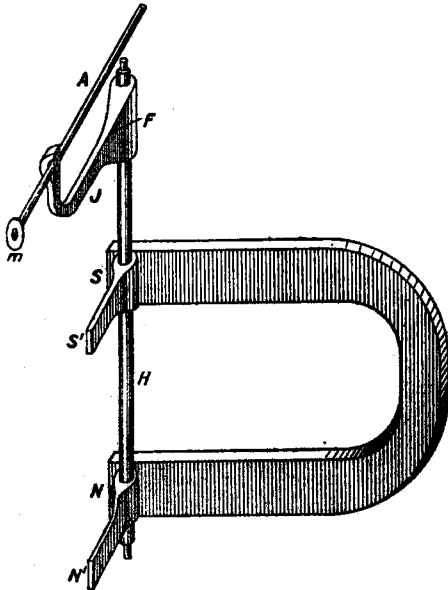

Fig. 6.—WHEATSTONE RECEIVER.—PERMANENT MAGNET. ARMATURES AND INKING DISC.

In addition to a tongue, which actuates a local sounder for key working, an extension of the armature spindle H above the permanent magnet carries a bent arm, J. At the bent end of J a slot is cut in which the axle A revolves. A is fixed at the end of the axle A. The inking disc m is

The clockwork mechanism gives rotary motion to the inking disc and its supply wheel, and also carries a paper slip

forward at any required speed between 7 and 60 feet a minute. When a marking current passes through the coils of the electro-magnets, the armatures S1, N1 are deflected to the left and the revolving disc *m* is pressed against the moving paper slip. The received signals are thus recorded in Morse symbols.

*There are three distinct methods of applying motive power to the mechanism, viz. :—*

- (i) By a coiled spring.
- (ii) By a descending weight.
- (iii) By the attachment of a small electric motor.

The mechanical action may be briefly described as follows, Fig. 7 :—

A train of wheels contained in the upper portion of the case causes the roller Q to revolve. The roller Q1 is pressed against Q by the spring R and rotates in the opposite direction to Q by frictional action. A roll of slip is accommodated in each of the drawers in the base of the instrument so that the paper may be changed without delay and fed from the second drawer when the first roll is exhausted. The paper passes over the slip-guide P and then between two steel projections, *a* and *b*, which keep it in the correct position for marking by the inking disc *m*. The latter, together with its supply wheel *d*, which revolves in an inkwell and conveys the ink to *m* by capillary action, are covered by a brass hood G, held in position by screw C. If the latter is slightly loosened, the hood G may be slipped off so as to expose *m* and *d* for cleaning purposes. The inkwell is secured in its place by the thumbscrew M. The starting and stopping of the mechanism is effected by means of the lever K. B is a removable plate to facilitate the cleaning and adjustment of the tongue and contact points. B and G are shown removed in Fig. 5.

The adjusting screw S controls the position of the electro-magnet coils with respect to the armatures. If the screw S is turned in a clockwise direction, a marking bias is obtained. For spacing, the screw is turned in the opposite direction.

The coils of the electro-magnets (Fig. 8) are each wound with two wires, each having a resistance of 200 ohms, which are then joined in "parallel" inside the instrument, so that the resistance between U and D and between (U) and (D) is 100 ohms. Outside the instrument, the coils may be joined either in "series," so that the total resistance is 200 ohms, or in "parallel," by which the resistance is reduced to 50 ohms. The cores of the electro-magnets consist of carefully concealed soft iron.

Having briefly explained the functions of the apparatus peculiar to Wheatstone automatic telegraphy, it now remains to deal with certain aspects of telegraph working which assume prominence in this system.

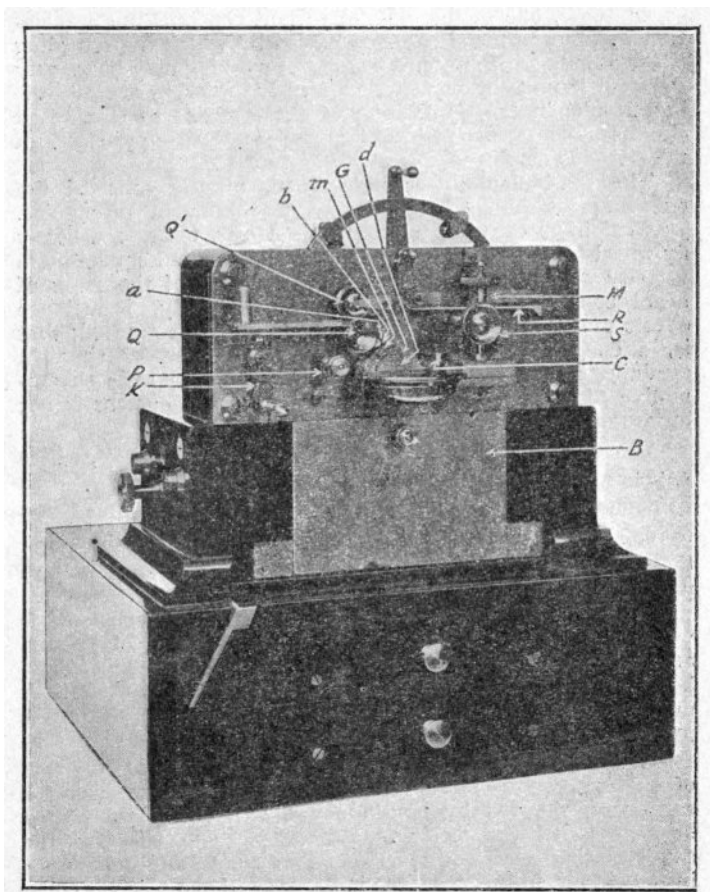
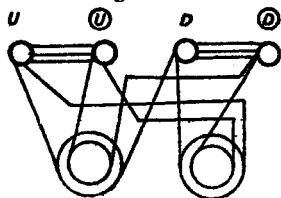

Fig. 7.—WHEATSTONE RECEIVER (LETTERED).



“COILS IN SERIES.”

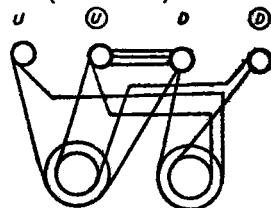

Fig. 8.

“COILS IN PARALLEL.”

Of these, one of the most important concerns the application to Wheatstone circuits by means by which the retarding effect of inductance upon the speed of working may be greatly reduced, if not entirely eliminated. In order to achieve the best results in the application of these means to fast speed circuits, it is necessary to understand clearly the principles of the methods employed.

**The self-induction, or inductance,** of the coils of the receiving instrument is analogous to inertia in mechanics. Just as, in mechanics, the application of a force to a heavy fly-wheel does not cause the latter to attain its maximum velocity at once, on account of the inertia of the mass of metal composing the wheel, so, in electricity, inductance causes the growth of a current in a circuit to be gradual; that is, a current occupies an appreciable amount of time in attaining its maximum value, and likewise, when the electro-motive force is removed, the cessation of the current is not instantaneous.

The electro-magnetic time constant of the circuit  $\frac{L}{R}$ , where  $L$  is inductance in henries and  $R$  the resistance in ohms, may be defined as the time required for a current to rise from zero to .632 of its maximum value. This quantity  $\frac{L}{R}$  is, therefore, the factor which determines the rate of working on any particular circuit.

In order to reduce the electro-magnetic time constant, it would appear to be only necessary to increase the total resistance of the circuit by adding non-inductive resistance. This, however, is not a complete remedy, as the current strength might be reduced below the working limit, necessitating a proportionate increase in electro-motive force.

Without having recourse to the method described, the rate of working can be more suitably increased by introducing a condenser, shunted by non-inductive resistance, and joined in series with the receiving apparatus. The effect of the condenser is exactly the reverse of that due to any inductance in the circuit, in this case, the inductance of the receiver coils. In the electro-magnetic circuit, when the electro-motive force is applied, the rise of current is retarded in relation to that force, or, in other words, the current "lags" behind the electro-motive force, whereas in the electro-static or condenser circuit the rise of the current is in advance of, or "leads" the electro-motive force.

The electro-static time constant of a circuit possessing capacity ( $K$  in farads) and non-inductive resistance ( $R$  in ohms) is equal to  $K \times R$ . Since inductance and capacity produce opposite effects, it is possible so to adjust the capacity



and resistance of a shunted condenser as to neutralize the inductance of the electro-magnetic circuit and so render it equivalent to a system possessing neither inductance nor capacity. This is effected by so adjusting K and R that the electro-magnetic and electro-static time constants are equal.

### TRAFFIC LIMITATIONS.

Under the best working conditions and using keyboard perforators, a simplex Wheatstone circuit working at 100 words a minute and employing 6 operators should dispose of 180 messages of average length per hour.

For continuous duplex working it is usual to provide a second circuit on which corrections and repetitions are obtained. In these circumstances a staff of 11 operators should complete 370 messages of average length per hour if the circuit is worked at 100 words a minute.

With a Creed receiver and printer in use, the staff would be reduced by 2 operators, making the total number employed 9 instead of 11.

### 2. THE GELL KEYBOARD PERFORATOR.

The general principles of the Gell keyboard perforator are as follows :—

Fig. 9. When a key (36) is depressed, a letter comb (28) is raised. This has projections on its upper surface which govern the selection of the punches for the required symbol and an extra single projection to control the length of paper slip to be propelled after the perforations have been made.

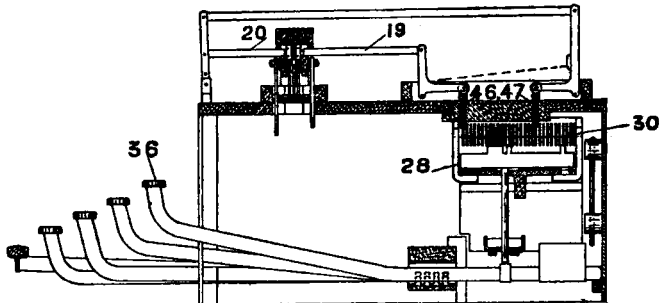

Fig. 9.

The projections raise thin parallel bars (30), which in turn raise guide pins (46 and 47) and so communicate mechanical movement to a series of interlocking bars (19 and 20), the ends of which pass through slots in the selected punches.

Fig. 10. When the depression of the letter key is approaching its downward limit, an electrical circuit is closed through contact screw (116), contact screw (119) and feed magnet coils (71).

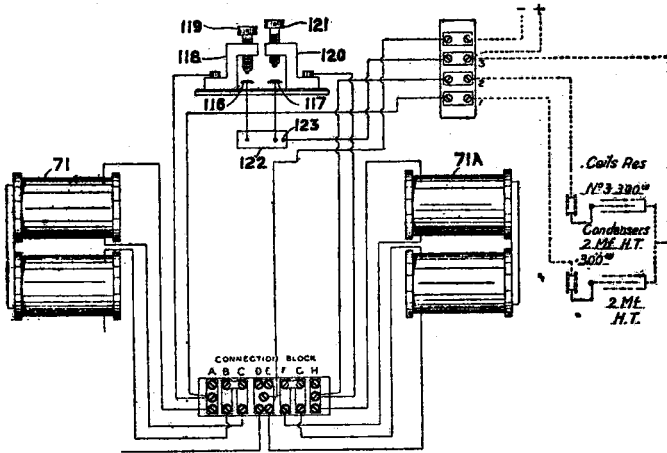

Fig. 10.

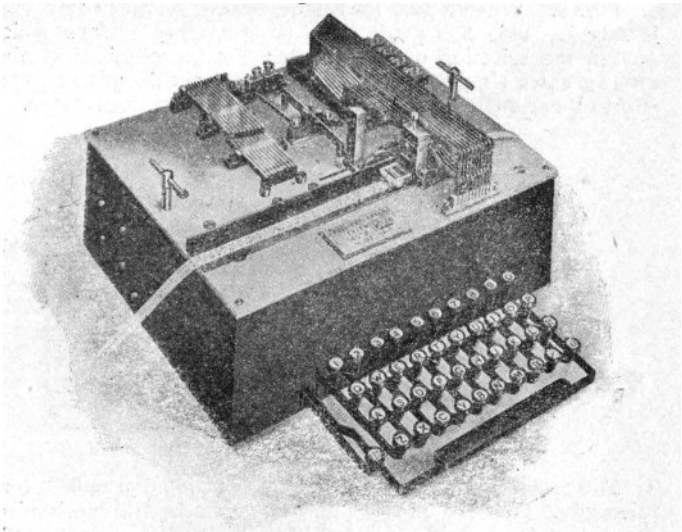

Fig. 11.

In descending, a yoke (not shown in the diagram) connecting the two plungers of the solenoid causes a click to pass over a certain number of teeth in a ratchet wheel in preparation to feed the paper forward when the armature is released.

Immediately after the feed magnet has been energised, the punching solenoid (71A) circuit is also closed through the right-hand spring contact (117) and screw (121). The yoke, in descending, draws down a slider which carries the marking and spacing punches held by the interlocking bars, and also the eleven centre-hole punches, to perforate the paper. The whole group of centre-hole punches are fixed in the slider and pass through the paper with each downward movement. If the preceding signal does not require the use of all the centre-holes, a number of the punches will pass through the unused perforations at the next depression of the slider. When key (36) is released, the punching solenoid circuit is first broken to allow the slider to withdraw the punches, the feed coils are immediately afterwards demagnetized and the paper slip travels forward under the control of the mechanism already described.

MECHANISM OF KLEINSCHMIDT KEYBOARD PERFORATOR.  
Main lever. Punch slides.

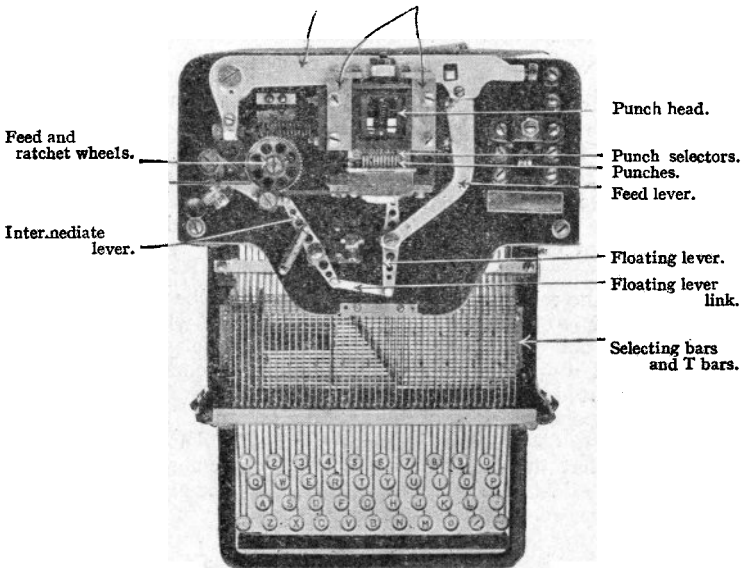

Fig. 12.

The coils of the solenoids may be joined either in series, as shown in the diagram, for use with 200 volts power supply, or in parallel, by removing the cross-connexions B—C, F—G on the connexion block and joining A—B, C—D, E—F, and G—H, for use on 100 volts supply circuits.

The instrument is capable of working at a speed of 80 words a minute, and in the hands of an expert operator the output, in messages of average length, may be taken as from 70 to 80 per hour.

### 3. THE KLEINSCHMIDT KEYBOARD PERFORATOR.

This instrument is designed to prepare Wheatstone slips similar to those already described in connexion with the Gell keyboard perforator, but in mechanical construction the two machines have few points of similarity.

In the Kleinschmidt perforator, the depression of a key acts on the appropriate selecting bar, which, by means of projecting tongues, selects the proper groups of T bars, and these, by their downward motion, communicate movement through connecting bars and links to the punch selectors, which are raised to a position immediately behind the punches to be operated.

The punches are arranged in three rows and are stepped so that the centre holes are first perforated, then the lower holes and finally the upper holes, the margin between the successive rows being about 5 mils. This reduces the amount of force necessary to perforate the paper. As with the Gell, the whole of the centre punches are actuated with each forward movement of the punch head.

When the selection has been made as described, an electrical contact is closed to energize the solenoid, which consists of a single coil and plunger controlling both the punching and paper feed mechanism. As the plunger descends, motion is communicated to a punch head sliding in a frame which carries a guide block containing the selectors. The selectors raised nearly fill the gaps between the guide block and punch head, so that the latter in its forward movement forces the selectors against the punches, which pass through the paper threaded between the die-plates.

The paper feed mechanism is controlled by a floating lever acting through an intermediate lever and link to operate the

feed pawl. The punch selectors, at their lower ends, have projecting leaves which act as stops for the floating lever. As the punch head moves into position, the free end of the floating lever rests against the raised leaf of the last selector of the group, and is locked by a small rack. This throws the opposite end of the floating lever forward and operates the intermediate lever and the feed-pawl, which passes over the required number of teeth on the ratchet wheel to feed the paper forward, in accordance with the length of the signal punched when the floating lever is released.

The coil ends of the solenoid are terminated on a connexion block in order that the windings may be readily connected either in series, for 220 volts supply, or in parallel, for use on 110 volts power systems.

It is claimed that the machine will work as fast as a typewriter, but for practical purposes 80 words a minute may be regarded as the limit. In messages per hour the output frequently reaches 70 to 80.

#### 4. WHEATSTONE AUTOMATIC SIMPLEX CIRCUITS.

Referring to the diagram of a complete Wheatstone set for simplex working (Fig. 13), the path of the current may be readily traced.

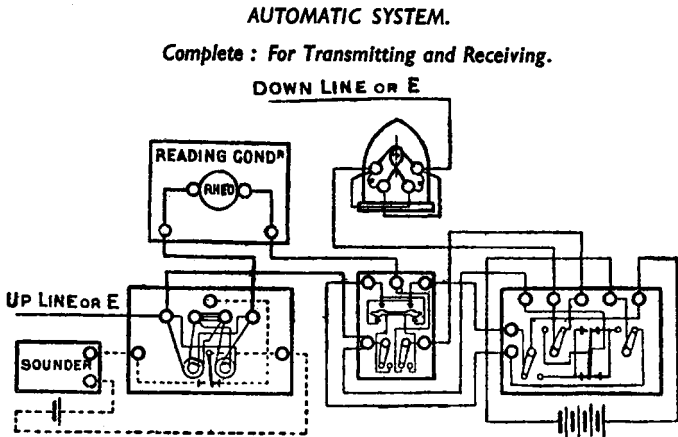

Fig. 13.

At the "Up" station the line is connected to the galvanometer, and the U terminal of the receiver is joined to earth.

At the " Down " office, these conditions are reversed, the line being joined to U of receiver and the galvanometer to earth.

The current from the positive pole of the battery at the " Up " station passes through the transmitter from C to MKC (Fig. 4), thence to the right-hand back terminal of the double current key. The switch of the latter being in the " send " position, the switch levers will rest on the studs shown disconnected in the diagram. Assuming the key to be depressed, the current will pass from the right-hand back terminal of the key through the key lever and right-hand switch lever to the right-hand side terminal of the key, thence to the centre back terminal of the transmitter (K) through the centre switch to the second back terminal (D) of the transmitter, which is joined to the galvanometer. The course is then through the galvanometer to line.

At the " Down " office the current enters from line at the U terminal of the receiver and leaves at (D) (Fig. 8), causing the tongue to pass on to the marking stop and so record the signal. After passing through the receiver, the current traverses the rheostat, which acts as a shunt on the reading condenser, the latter being charged to a degree dependent on the capacity of the condenser and the difference of potential between its terminals. The path of the current is then from the rheostat to the centre back terminal of the key, the switch of which is in the " Receive " position. The current passes through the key *viâ* the right-hand switch lever to the right-hand front terminal to K of transmitter, through the centre switch of the transmitter to galvanometer, and so to earth.

The current may then be assumed to pass through earth to the " Up " station. When it reaches the U terminal of the receiver, the path is to the left-hand front terminal of the key, through the left-hand switch lever to left-hand key lever, then to left-hand back terminal, and from thence to MKZ of the transmitter, through the right-hand lever switch of the latter to Z of transmitter, and so back to the negative pole of the " Up " battery.

When the transmitter is brought into action, the battery and line connexions are severed from the key, and the compound lever of the transmitter performs all the functions of the key lever by reversing the currents sent to line under the control of the perforated slip.

From the " Down " station, the current can be similarly traced through its course to the " Up " station.

## 5. WHEATSTONE AUTOMATIC DUPLEX CIRCUITS.

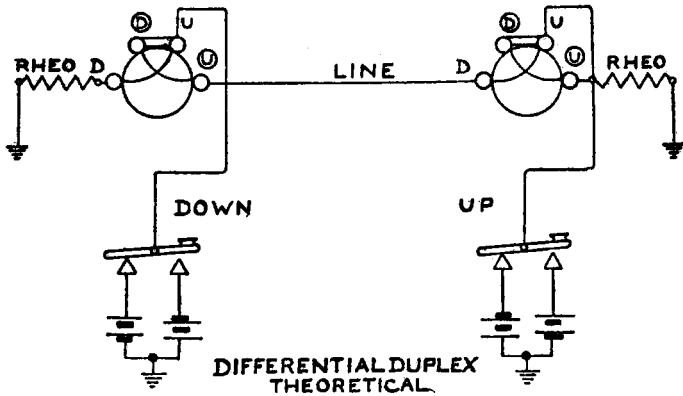

Fig. 14.

“Duplex” working is the term applied to any system of telegraphy which permits of messages being sent over a single circuit in both directions at the same time. The conditions which render such a method possible are :—

- (a) That outgoing current from either office shall not actuate the receiving apparatus at that office, and
- (b) That the receiving instrument at each station shall respond to the signals sent from the distant station.

There are two systems of duplex working in general use on P.O. circuits :—

- (i) **The Differential**, which is employed on overhead lines and underground cables of moderate length, and
- (ii) **The Bridge system**, which is adopted on long underground circuits and submarine cables.

(i) **The Differential duplex** may be explained with reference to Fig. 14, which shows a battery, key, polarized relay and rheostat at each station.

At the down office the positive pole of the spacing battery is joined to the back stop of the key and the negative pole is connected to earth. The current may be traced from the positive pole through the key to the back terminals of the polarized relay, which are strapped together. If the resistance in the rheostat equals the resistance of the line, one

coil of the distant station's relay and the spacing battery at that office, the outgoing current will divide into two equal parts, one of which will pass through one coil of the relay in a marking direction (U to D), and through the rheostat to earth and to the negative pole of the battery. This is called the compensation circuit. The other half of the current will pass through the second coil of the down station's relay (D) to (U) in a spacing direction to line, through one coil of the up station's relay in a spacing direction (D to U) to the back of relay, through the back stop of the key and the up-spacing battery to earth, whence it may be assumed to pass through the earth to the negative of the down station's battery.

In the down station's relay the two equal currents passing through the two coils in opposite directions leave the tongue unaffected while the current through the up station's relay is, as stated, in a spacing direction.

At the up station the positive pole of the spacing battery is joined to earth, and as the resistance between the two stations by this path is negligible in effect the spacing batteries at the two offices are joined in series.

The line current from the up office battery may be traced through the earth to the negative of the down office battery and so to the back of the relay.

A small portion of current, which may be ignored, will enter the down station's rheostat from earth, pass through both coils of the relay in a spacing direction and return to the up office *via* the line. The greater part of the current will, however, pass through one coil of the down relay in the spacing direction to line, through one coil of the up relay still in the spacing direction to the up key, and back to the negative pole of the battery. At the same time as this is taking place a current of equal strength passes from the positive pole of the up battery to the earth connexion of the rheostat, through the rheostat and one coil of the up station's relay in a marking direction, and so back to the negative pole of the battery. At the up office, therefore, the effect of the home battery on the relay is nil. These conditions may be stated as follows :—

(a) With both keys at rest the outgoing spacing current does not actuate the receiving apparatus at the home station.



(b) Both relay tongues are kept on the spacing contacts by the action of the distant battery.

When the up station's key is depressed the outgoing current is reversed. The line portion neutralizes the spacing current from the down station, thus leaving the current through the rheostat to act alone. This is now in a spacing direction so that the tongue is still held on the spacing stop.

At the down station, the current through the line coil is neutralized by the up station's battery, but the home current through the rheostat is still in a marking direction. The tongue, therefore, leaves the spacing contact and passes over to marking.

The effects produced by the different positions of the two keys may be summarized as follows :—

(a) When both keys are at rest the line current exceeds that of either compensation circuit and passes through both relays in a spacing direction.

(b) With the up office key depressed and down office key at rest there is no line current. The compensation current at the up station is in a spacing direction, while that through the down station compensation circuit is in a marking direction.

(c) With the down office key depressed and up station's at rest, the line currents are neutralized. At the down station the compensation current is in a spacing direction, and at the up station the compensation current is in a marking direction.

(d) With both keys depressed the conditions may be compared with (a), but as both batteries are reversed an excess of marking current passes through both relays.

The diagram of a full set of double current duplex apparatus is given as Fig. 15.

From the description given of the Wheatstone Automatic system it will be readily understood that by adding a Wheatstone Transmitter on the sending side and a Wheatstone Receiver in place of the polarized relay, fast speed duplex working should be possible. Plates 61 and 62 in the Telegraph Diagram Book illustrate such sets for Primary and Secondary battery working respectively.

(ii) The principle of the Bridge Duplex system is similar to that of the Wheatstone Bridge Testing Instrument.

## UNIVERSAL BATTERY SYSTEM.

Double Current, Duplex and Single : Up Office.

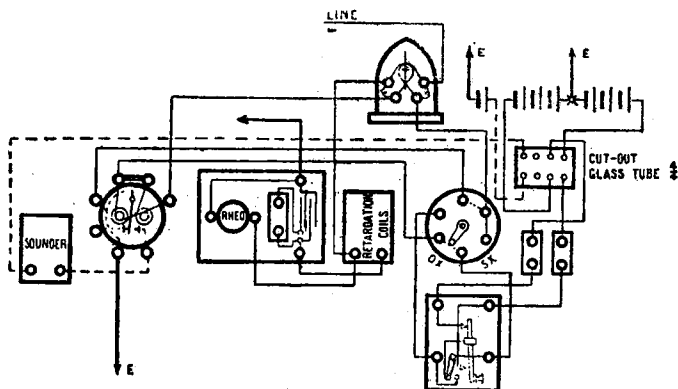

Fig. 15.

Two coils of high resistance usually  $3,000\Omega$  each and known as "Coils, Duplex,  $3,000\Omega + 3,000\Omega$ " are contained in a box which has three connexion terminals on its upper surface. Each coil forms one ratio arm of the bridge. The third arm consists of the line and distant apparatus and the fourth arm is represented by the rheostat.

Theoretically the system may be shown as in Fig. 16.

Across each of the  $3,000\Omega$  bridge arms is joined a condenser. These are known as signalling condensers and their function is to apply the full voltage of the battery to the end of the line at the instant the current is reversed. At the moment of change, the condensers practically short-circuit the  $3,000\Omega$  coils and cause the electrostatic capacity of the line to be satisfied more rapidly than would be the case if resistance coils without condensers were used. It will be seen that the receiving apparatus takes the place of the galvanometer usually associated with the Wheatstone Bridge and that so long as there is no difference of potential between points A and B at the down station no current will pass through the receiving instrument at that office. The same remark applies to the corresponding points at the up station.

As the Bridge duplex is principally used on long distance cable circuits of high electrostatic capacity, it is necessary that the balancing artificial circuit should also possess similar qualities in order to reproduce as nearly as possible the characteristics of the line. In addition, therefore, to the rheostat which balances the resistance, condensers  $c_1$ ,  $c_2$ , and

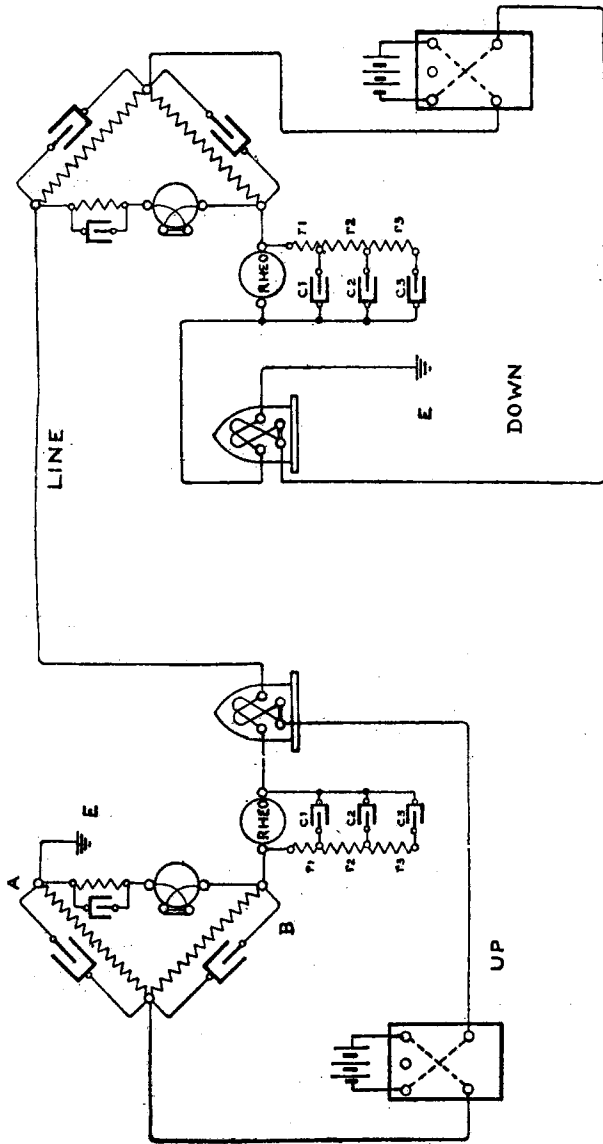

BRIDGE DUPLEX - THEORETICAL

Fig. 16.

c3, and resistance coils, r1, r2 and r3, are inserted in the balancing circuit, r1 and c1 represent the near end of the cable, r2 and c2 the intermediate portion, and r3 and c3 the distant end. The resistances r1, r2, and r3 time the rate of charge and discharge of the condensers in such a way as to correspond with the portions of cable they represent.

Joined in series with the receiving apparatus is a shunted condenser known as the "Reading Condenser." Its chief function is to neutralize the effects of inductance in the receiving coils of the instrument and so cause it to respond immediately to any change in the direction of the line current. Further information on this subject is given in the description of the Wheatstone Receiver Instrument. With both keys at rest, the current through each relay is in a spacing direction.

The depression of the key at either station causes a rearrangement of the potentials in the various arms of the bridge, and a current passes through the receiving apparatus at the distant station in such a direction as to produce a mark.

When both keys are depressed the difference of potential between the terminals of the receiving apparatus at each end of the line is such that a marking current passes through each instrument.

On long underground cable circuits it is necessary to use a metallic loop, without earth, for the purpose of avoiding inductive disturbances between the various lines. In the theoretical diagram, the removal of the earth connexion at each office and the attachment of a second line wire to the terminals thus left free would represent the conditions without further alteration. A method of wiring Wheatstone Automatic Bridge Duplex sets is given in plate 64 of the Telegraph Diagram Book, 1906 edition, which refers to secondary cell universal installations.

By the addition of a Gulstad vibrating relay to the normal Bridge Duplex Wheatstone set, it has been possible to increase materially the speed of long distance circuits. Diagram T.G. 244 indicates the method of wiring.

The Gulstad relay could not be applied to circuits worked on the differential duplex system, but the P.O. have designed and constructed a vibrating relay, known as the relay, standard "G," which is suitable for either Bridge or Differential working. This instrument has proved so successful that many long circuits are now worked differential at speeds which could previously be approached only by the adoption of the Bridge method with Gulstad relays. In some cases, the improvement has been so great as to allow of the withdrawal of repeaters at intermediate stations.

The vibrating relay is used on Baudot as well as on Wheatstone circuits and could be applied to any other multiplex or fast speed automatic system.

## 6. THE CREED WHEATSTONE SYSTEM.

In the usual method of Wheatstone working, the operations which cause the greatest loss of time are, firstly, the preparation of the punched slips at the transmitting offices; secondly, the translation of the received signals at the intermediate stations; thirdly, the re-perforating for re-transmission; and, lastly, at the terminal office, the writing up or printing of the received signals.

The first part of the problem, the simplification of the preparation of the punched slips, may be solved readily enough by means of a keyboard perforator such as the Gell or Kleinschmidt.

The remaining causes of time loss are greatly reduced by means of the Creed Receiving Perforator and the Creed Printer.

**The Creed Receiving Perforator.**—The receiving perforator is designed to facilitate re-transmission and to save manual labour in the reception of telegrams.

For instance, a station " B " may have to transmit telegrams received from a station " A " to stations beyond.

Ordinarily in Wheatstone working the messages from " A," which are to be forwarded by " B," are received by the latter in the usual Morse signals. In order that they may be forwarded, an operator at " B " has to prepare a new Wheatstone slip similar to that which was prepared at " A " in the first instance.

The object of the Creed receiving perforator at " B " is to avoid the necessity of preparing a fresh Wheatstone slip by hand, and to perform the same operation automatically by means of the signals received on the line relay.

The mechanism for accomplishing this consists of :—

(1) A relay.

(2) A perforator; this latter in its turn comprises three principal parts :—

(a) Punches and a system for actuating them.

(b) A mechanism for carrying the slip forward at a uniform speed with that of the transmitter at the sending station.

(c) A method of holding the slip firm whilst it is being perforated, and then releasing it as soon as the perforation has been accomplished.

The two operations (a) and (c) are performed by pneumatic agencies, whilst the operation (b) is fulfilled by the aid of an electric motor.

The line relay is actuated by currents in the usual way. The local connexions are shown in Fig. 17.

Within the Creed receiver is another relay similar in construction to the Post Office standard relay (Fig. 18), with the exception that in lieu of the usual tongue the spindle of the

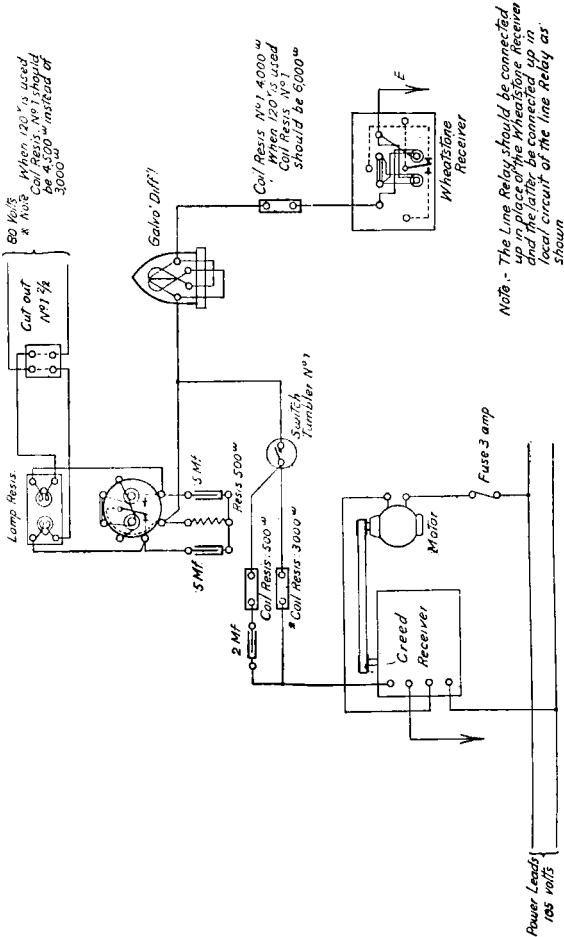
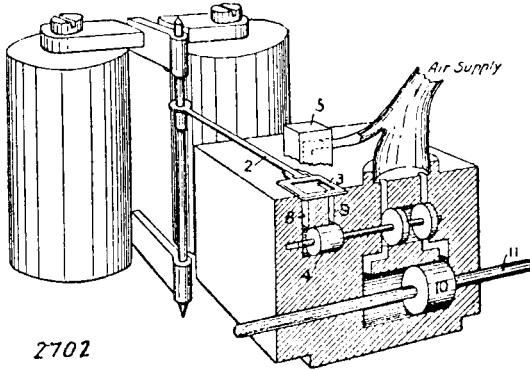

Fig. 17.

armature carries a light arm 2, at the end of which is an arrangement for opening and closing a small air valve 3, which controls the supply of air *via* the block 5 and the channels 8 or 9 to a small piston, 4. The pressure of the block 5 is regulated by means of the spring 6 (Fig. 19) and the adjustable screw 7. The small piston responds to the movements of the relay in accordance with the currents received from the line.



2702

Fig. 18.—SKETCH OF RELAY.

On an extension of the small piston-rod is an arrangement for controlling the air supply to a larger piston, which, by means of a rod passing through it, acts in turn on the adjacent

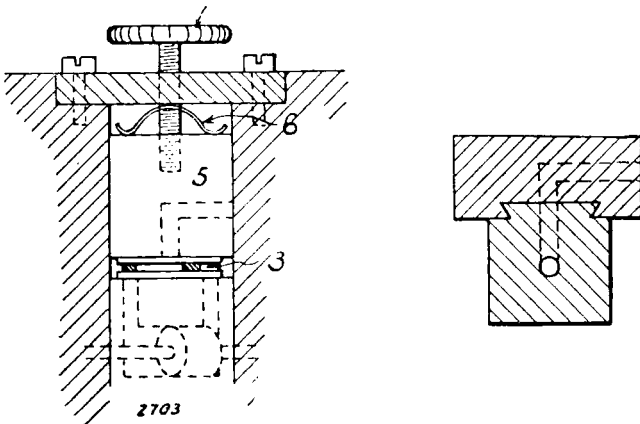

2703

Fig. 19.—DETAILS OF AIR VALVE.

arms of the system of bell-crank levers 1 and 2 (Fig. 20). The movement of the piston-rod and the levers 1 and 2 is regulated by means of the adjustable buffers 25. Attached to the arms 3 and 4 are two bifurcated hard-steel strikers 5 and 6, the free ends of which force forward the correcting rods 7 and 8 and the punches 9 and 10.

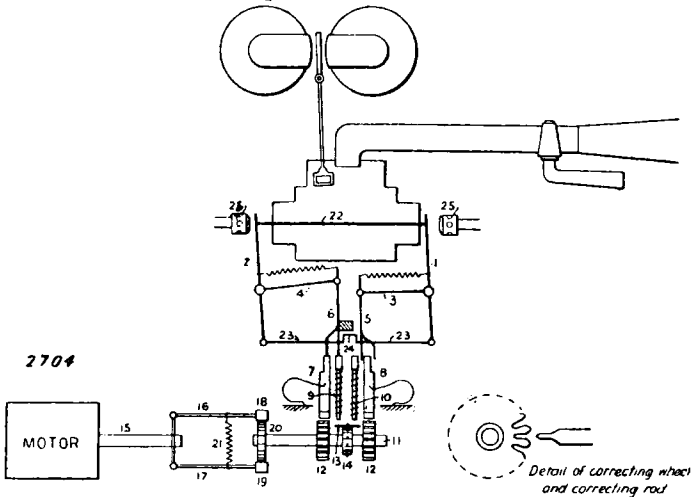

Fig. 20.

CREED RECEIVER. SKETCH OF MECHANICAL ARRANGEMENT.

The correcting rods and punches are mounted and guided in a separate block with the die-plates of the perforator and the feed-wheel spindle 11.

The correcting rods 7 and 8 have flattened blades at one end, which, when thrust forward, enter the slots of the correcting wheels 12. Retracting springs are provided to restore the rods to their normal positions against stops in the punch blocks. The punches are equipped with springs in like manner.

The Wheatstone paper slip 13 is previously centre-holed in order that it may be fed forward. It is placed in the paper guide, and by means of the centre-holes engages with the star-wheel 14, and is led upwards between the die-plates and past the punches. The star-wheel and the correcting wheels are fixed to the spindle 11.

When the point of either rod 7 or 8 is thrust forward by the striker 5 or 6, it enters the space between the teeth of the correcting wheel, and thus adjusts the position of the wheel



and holds it and the paper firmly in such a manner that the corresponding punch 9 or 10 will perforate the paper exactly opposite the centre or feed-holes.

The spindle 11 is rotated by an electric motor, whose spindle, 15, is connected to it by means of jointed arms, 16 and 17, which have friction blocks, 18 and 19, pressing on the disc 20. The friction is regulated by means of spring 21, which can be moved to the right or left along the rods 16 and 17.

The action of the apparatus is as follows :—

When a current is received in the relay 1 (Fig. 18) its armature, 2, moves to the right or left, dependent on the direction of the current through the relay coils.

The following series of mechanical operations take place in the latest form of Creed receiver of the pneumatic type.

When a " marking " current is received, the light arm 2 moves to the left. This opens the air-channel 8, and the pressure of the air forces the piston 4 to the right; this is connected with the main valve, which is opened in like manner, and the main piston 10 is driven to the right also.

The further action will now be seen by reference to Figs. 18 and 20.

The motion of the main piston shaft 11 (Fig. 18) and 22 (Fig. 20) is transmitted by means of the bell-crank 1 and the link 23 to the bell-crank 2, which, in turn, causes the left-hand striker 6 to force the sharp point of the correcting rod 7 between the teeth of the correcting wheel 12, thus adjusting the feed-wheel 14, if necessary, and pressing the punch 9 through the paper slip 13. The tappet piece 24 on the link 23 now comes in contact with the striker 6 and pushing it aside from the correcting rod and punch, allows them to withdraw from the correcting wheel and paper respectively through the action of the retracting springs and assume the normal position.

When the line-current is reversed, the armature 2 (Fig. 18) of the relay 1 is moved in the opposite direction, the piston-rods are reversed in their action, and another operation similar to that described causes the correcting rod 8 and punch 10 (Fig. 20) to be actuated.

As the operation of forcing the correcting rods and punches forward occupies only about 1/300th of a second, the time during which the movement of the feed-wheel is arrested is practically negligible, and the difference between the dots and dashes on the slip depends, therefore, on the time-interval between the successive spacing and marking contacts, during which time the tape is allowed to travel forward. In order to

allow for the interval of time occupied by the reversal of the currents required for signalling a "dot," during which period the slip has travelled forward a little, the right-hand punch and correcting wheel are given a lead, so that, although the spacing punch come into action a short time after the marking punch, the spacing perforation is made immediately opposite the same centre hole as the marking perforation.

The air supply is obtained by means of a small pump placed in the engine room, and is delivered at a pressure of 30 to 35 lbs. per square inch. A container is placed near the apparatus so as to avoid fluctuations of pressure when a variation in the number of instruments at work takes place.

The maximum speed of working which has been obtained experimentally by the Department is 215 words per minute, but a speed of 150 words per minute is generally regarded as the maximum for instruments of the latest type and 120 words per minute for the older apparatus.

**The Creed Printer.**—The printer translates the signals on the received perforated slip and prints them in Roman characters on a paper tape. The tape is afterwards gummed on to an ordinary telegram form.

The action of the printer will be understood by means of the skeleton diagram shown in Fig. 21.

The perforated slip, which is identical with ordinary Wheatstone slip, is shown passing through the printer on the right-hand of the figure.

The roll of Morse paper which receives the printing is placed on a wheel similar to that used in the Wheatstone receiver, and, guided by a roller, is then drawn forward between the connecting rods of the type bars by means of two rollers (between which it passes), which are driven by the mechanism. On its journey the slip passes over a printing platen and under a typewriter ribbon.

The perforated paper is fed upwards by means of a star-wheel fitted on a spindle carrying a toothed wheel, which is rotated, as desired, by the paper-lifting rack. The movement of the rack is obtained by means of a cam on the main shaft of the printer, which is belt-driven from an electric motor.

The slip is drawn forward, letter by letter, in front of ten pairs of selecting needles (one pair only is shown in the figure), which, by means of small springs, are pressed against the paper and made to enter the perforations that may happen to be immediately in front of them.

One of each pair of needles is connected to the hinged extension of a thin perforated plate or stopper sliding in the path of the air valves. Each of the ten slide plates can take two positions, and they thus provide a number of different

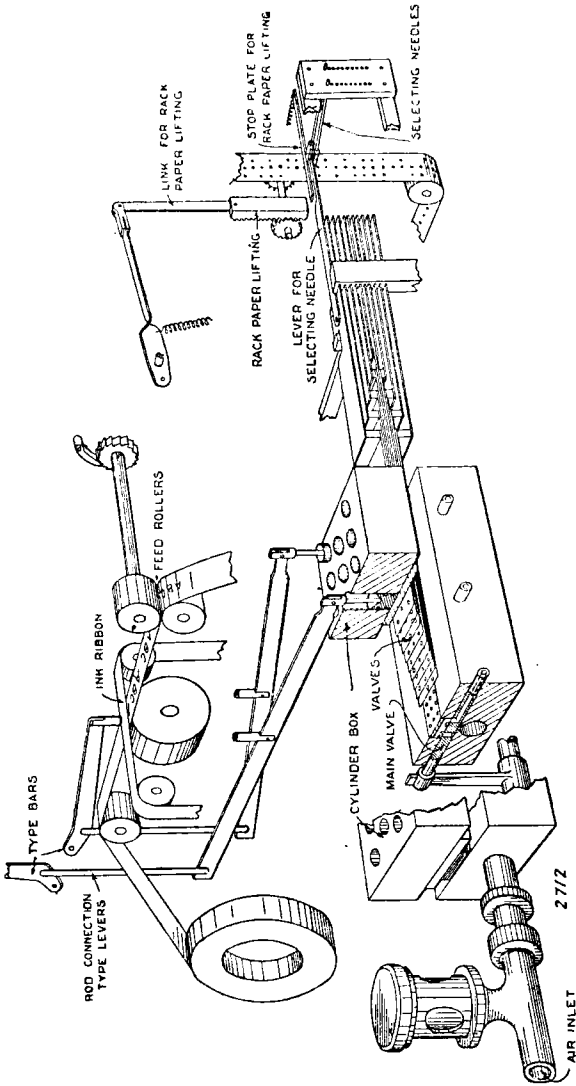

Fig. 21.  
 CREED PRINTER. SKELETON DIAGRAM OF MAIN PARTS.

combinations, every one of which opens one complete and particular passage through them. Air under pressure is admitted through the main valves below these plates, and through the passage thus opened to small cylinders placed immediately above them.

The type levers terminate in pistons which fit into the small cylinders, and as the plates are displaced the air acts on one or other of these pistons, and causes the corresponding type lever to print the letter or sign on the paper.

The movement of the slide valves or plates is determined by the paper-lifting rack. For this purpose the rack is given, independently of its up-and-down movement, a side motion, by means of which it pushes the slide valves which have been brought into its zone of action by the movement of the selecting needles.

The vertical motion of the paper-lifting rack is determined by the position of the first blank space in the slip; that is to say, it corresponds to the length of the letter which has been selected.

To provide for the variable vertical movement of the rack there is a group of ten space levers which are normally in its path, but when the selecting needles pass through the holes in the slip they press these levers aside and thus allow the rack to descend.

The rack can, therefore, move downwards as far as the space signals between the letters, which it cannot pass, because the position of the corresponding space lever has not been altered.

In its downward movement the rack does not engage with the toothed wheel which governs the movement of the paper, but at the end of its vertical motion it is moved laterally by means of a cam on the main spindle, and thus presses against the selected slide valves, and then engages with the toothed wheel of the paper-moving mechanism. The rack then rises and the slip is drawn upward, and as the amplitude of the rack's rising motion is equal to that of its descent, the paper is lifted exactly the length of the letter which has just been printed.

The slip is now in position ready for the selection of the next letter. The stop plates are formed of thin plates of steel; they are each provided with a hinged extension, which can follow the movements of the selecting needles, and at the same time the extension and the plate are free to move in a direction at right angles to the needles. The extension is provided with a shoulder against which the paper-lifting rack presses in its lateral movement.

The admission of the air into the distributor is controlled by four main valves, which are actuated by a cam on the main shaft only after the paper-lifting rack has pushed the selected stop plates into the working position. After the letter has been printed the four valves move into a second position, the air then escapes, and at the same time the stop plates are brought back to their normal position, by means of a cam on the main shaft.

It may be remarked that the selecting needles may enter the holes of the following letter or letters in the slip, but they do not affect the printing of the proper signal, because the stopping places are not actuated by the paper-lifting rack, as it does not descend beyond the first space after the letter which is being printed.

As previously stated, there are twenty selecting needles (10 pairs), but only the ten acting on the lower row of holes in the Wheatstone slip are attached to the valves; the other ten are not required for selecting purposes, but are used for shifting the space levers for the first portion of the dash signals.

The typewriter ribbon is fed forward by mechanism, which is actuated by the same cam that moves the paper slip.

In addition to its forward movement it is given an oscillatory motion, which brings all parts of the ribbon under the letter types in turn, and thus adds materially to its life.

Improved Creed Receivers and Printers in which the functions hitherto performed by the air pressure are effected electrically, were brought into use in 1925/26 but certain modifications are in course of being effected and descriptions of the apparatus cannot yet be provided.

#### 7. METHOD OF TESTING SPEED.

A convenient method of testing the speed at which the Wheatstone transmitter is running is as follows :—

(1) At the sending office, a perforated slip with the letters A, B, C, repeated, and having two spaces between each letter, is prepared (see Fig. 22). A length of 3 or 4 feet of slip is sufficient.

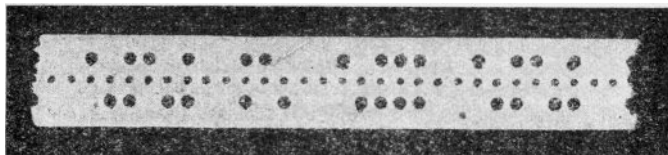

FIG. 22.—PERFORATED SLIP SHOWING THE LETTERS C, A, B, C, AND TWO SPACES BETWEEN EACH LETTER.

(2) The ends are carefully gummed together so that the slip forms a loop which can run continuously and accurately.

(3) The speed of working, in words per minute, is equal to the number of groups of A, B, C, passing through the transmitter in 50 seconds (or twice the number of groups in 25 seconds).

From this, it will be seen that the receiving station can determine the speed without reference to the sending station.

===== LIST OF =====  
**Technical Pamphlets for Workmen**

(Continued)

**GROUP D—continued.**

20. Superposed Circuits. Transformers. Bridging Coils and Retardation Coils.
21. Call Offices.
22. Units, Amplifying. (*Not on Sale.*)

**GROUP E.**

1. Automatic Telephony. Step-by-Step Systems.
2. Automatic Telephony. Coded Call Indicator (C.C.I.) Working.
3. Automatic Telephony. Keysending " B " positions.

**GROUP F.**

1. Subscribers' Apparatus. Common Battery System.
2. Subscribers' Apparatus, C.B.S. Part I—C.B.S. No. 1 System.
3. Subscribers' Apparatus. Magneto.
4. Private Branch Exchanges—Common Battery System.
5. Private Branch Exchange—C.B. Multiple No. 9.
6. Private Branch Exchanges—Magneto.
7. House Telephone Systems.
8. Wiring of Subscribers' Premises.

**GROUP G.**

1. Maintenance of Secondary Cells.
2. Power Plant for Telegraph and Telephone Purposes.
3. Maintenance of Power Plant for Telegraph and Telephone Purposes.
4. Telegraph Battery Power Distribution Boards.

**GROUP H.**

1. Open Line Construction, Part I.
2. Open Line Construction, Part II.
3. Open Line Maintenance.
4. Underground Construction, Part I—Conduits.
5. Underground Construction, Part II—Cables.
6. Underground Maintenance.
7. Cable Balancing.
8. Power Circuit Guarding.
9. Electrolytic Action on Cable Sheaths, etc.
10. Constants of Conductors used for Telegraph and Telephone Purposes.

**GROUP I.**

1. Submarine Cables.

**GROUP K.**

1. Electric Lighting.
2. Lifts.
3. Heating Systems.
4. Pneumatic Tube Systems.
5. Gas and Petrol Engines.