

No. 195

**The Institution of Post Office Electrical Engineers.**

**The Introduction of Automatic Switching  
to the Inland Teleprinter Network**

by

H. E. WILCOCKSON, A.M.I.E.E.

and

C. W. A. MITCHELL, A.M.I.E.E.

A Paper read before the London Centre of the Institution on 14th March, 1949,  
and at other Centres during the Session.

The objects of the Institution of Post Office Electrical Engineers are to promote the general advancement of electrical telegraphic and telephonic science and its application, and to facilitate the exchange of information and ideas on these and allied subjects amongst the members ; but, in furthering these objects by the publication of selected papers read at meetings of the Institution, the Council does not accept responsibility for the statements made, or the opinions expressed, by the author of any such paper.

**The Institution of Post Office Electrical Engineers**

**The Introduction of Automatic Switching  
to the Inland Teleprinter Network**

by

H. E. WILCOCKSON, A.M.I.E.E.

and

C. W. A. MITCHELL, A.M.I.E.E.

A Paper read before the London Centre of the Institution on 14th March, 1949,  
and at other Centres during the Session

## CONTENTS

1. INTRODUCTION.
2. LAYOUT OF THE NETWORK.
  - 2.1. Transmission Limits.
  - 2.2. Resistance Limits—Physical Lines.
  - 2.3. Impulsing Limits.
  - 2.4. Possible use of Regenerative Repeaters.
3. LINE AND SWITCHING PLANT—BASIS OF PROVISION.
  - 3.1. Teleprinter Trunk Circuits.
  - 3.2. Lines to Teleprinter Offices.
  - 3.3. Zone or Area Office Teleprinters.
  - 3.4. Switching Equipment.
  - 3.5. Point-to-Point Teleprinter Circuits.
  - 3.6. Duplex Positions.
  - 3.7. Enquiry Positions.
  - 3.8. Grade of Service Tests.
  - 3.9. Traffic Recording.
4. TRUNKING ARRANGEMENTS.
  - 4.1. Area Numbering Scheme.
  - 4.2. Typical Trunking Arrangements.
  - 4.3. Night Service Arrangements.
  - 4.4. Auxiliary Overflow Centres.
  - 4.5. Arrangements for Bothway Circuits.
5. CONVERSION PROGRAMME AND INITIAL SCHEME.
6. TELEPRINTER POSITION EQUIPMENT.
  - 6.1. The Teleprinter No. 11B.
  - 6.2. The Dialling Unit.
7. OPERATING FACILITIES AND SERVICE SIGNALS.
8. SWITCHING CENTRE EQUIPMENT.
  - 8.1. General.
  - 8.2. Relay Sets and Selectors.
  - 8.3. Racks and Frames.
  - 8.4. Engineering Control Board.
  - 8.5. Signal Generators and Associated Equipment.
9. SIGNALLING PRINCIPLES.
  - 9.1. General.
  - 9.2. Line Supervisory Signals (Local Calls).
  - 9.3. Line Supervisory Signals (Trunk Calls).
10. CIRCUIT FEATURES.
  - 10.1. Teleprinter Station Circuit.
  - 10.2. Station Line Circuit.
  - 10.3. Group Selector.
  - 10.4. Final Selector.
  - 10.5. Suspense Relay Set.
  - 10.6. O/G Selector Level Relay Set.
  - 10.7. Trunk Relay Set.
11. SPECIAL SERVICES.
  - 11.1. Special Services Final Selector.
12. TESTING EQUIPMENT.
  - 12.1. The Test Desk.
  - 12.2. Speaker and Test Sets.
  - 12.3. Portable Testers.
  - 12.4. Routine Testers.
13. OBSERVATION EQUIPMENT.
14. CONCLUSIONS.

# The Introduction of Automatic Switching to the Inland Teleprinter Network

## 1. INTRODUCTION.

A detailed survey of the problem of providing a national automatic switching system for the Inland Public Telegraph Service was commenced by the Intersectional Telegraph Switching Committee in 1935, at the instance of the Retransmissions Committee. The object of the scheme was to enable any teleprinter office to obtain connexion with any other teleprinter office by automatic selection, and so to establish a through telegraph circuit by switching together the various intermediate telegraph links between the offices concerned. By eliminating the necessity for the retransmission of telegrams at intermediate points, inherent with the point-to-point system then in operation, a reduction in the transit time of telegrams would be achieved, as well as material reduction in annual charges for the service as a whole, due to the consequential saving in staff costs. It should be noted that even with the increased engineering plant charges of the switching network, plant charges represent only a small proportion of total charges.

Experimental equipment, using standard step-by-step telephone switching apparatus as far as practicable,

was developed to meet the needs of the projected scheme, and installed in London and a number of provincial centres. Extensive engineering and traffic tests were carried out, and demonstrated the feasibility of providing a satisfactory switched service. As a result a decision was taken in 1937, to convert the Inland network to automatic working. All work in connexion with the project was suspended, however, at the outbreak of war in 1939.

In the summer of 1945, a review of the scheme was undertaken, and the equipment which has been developed as a result incorporates the latest developments in design technique, and allows for the possible subsequent integration of the public switched service and the projected telex service based on the use of exclusively telegraph channels.

## 2. LAYOUT OF THE NETWORK.

The layout of the switching network is based on the provision of 24 switching centres (Fig.1), the number and location of which have been determined on economic grounds after due consideration of the traffic and engineering requirements.

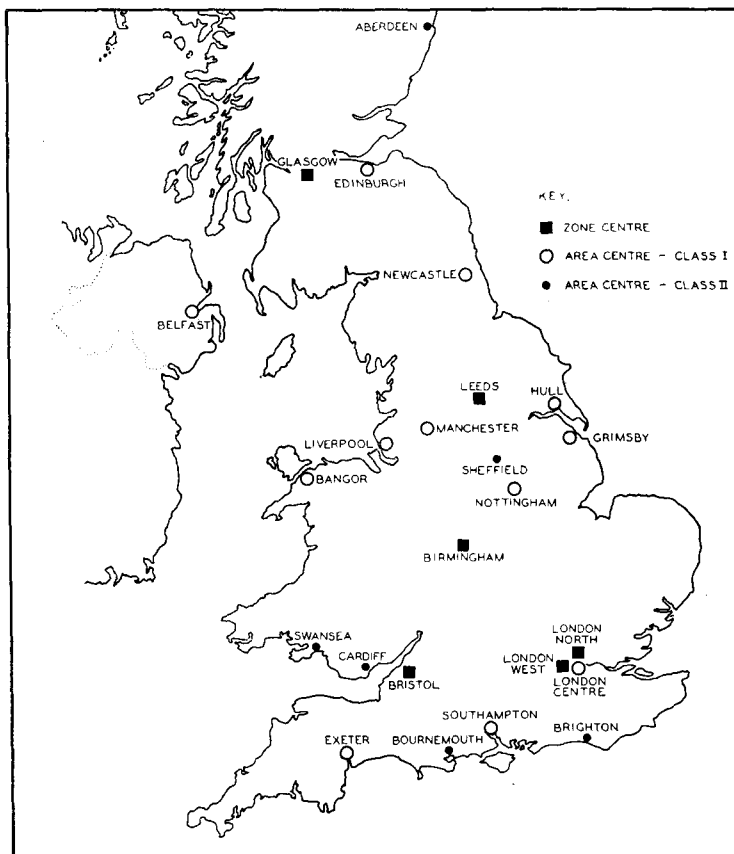

FIG. 1.—TELEPRINTER AUTOMATIC SWITCHING SYSTEM.  
LAYOUT OF SWITCHING CENTRES.

To ensure adequate margin for the satisfactory operation of any two teleprinters when interconnected via the switching network, the switching centres have been divided into three categories, determined by the manner in which they are interconnected with other switching centres, and the characteristics of the station line circuits which may be connected to them, as follows:—

*Zone Switching Centres*

Birmingham	Glasgow	London North
Bristol	Leeds	London West

These centres will have direct teleprinter trunk circuits connecting them to all other Zone Switching Centres, to all Area Switching Centres Class 1, and to Area Switching Centres Class 2 where justified by traffic.

Station lines connecting teleprinter offices to these centres may be either wholly physical lines having not more than 10 per cent. distortion, or VF channels with physical extensions having negligible distortion.

*Area Switching Centres Class 1*

Bangor	Grimsby	Manchester
Belfast	Hull	Newcastle
Edinburgh	Liverpool	Nottingham
Exeter	London Centre	Southampton

*Area Switching Centres Class 2*

Aberdeen	Brighton	Sheffield
Bournemouth	Cardiff	Swansea

Each of these centres will be directly connected by teleprinter trunk circuits to at least one zone switching centre, and to other switching centres where justified by traffic.

Only wholly physical station line circuits—having negligible distortion—may be connected to these centres.

The teleprinter trunk circuits interconnecting the switching centres, the network for which is shown in Fig. 2, will normally be VF channels, but exceptionally physical circuits may be employed between the three switching centres in London.

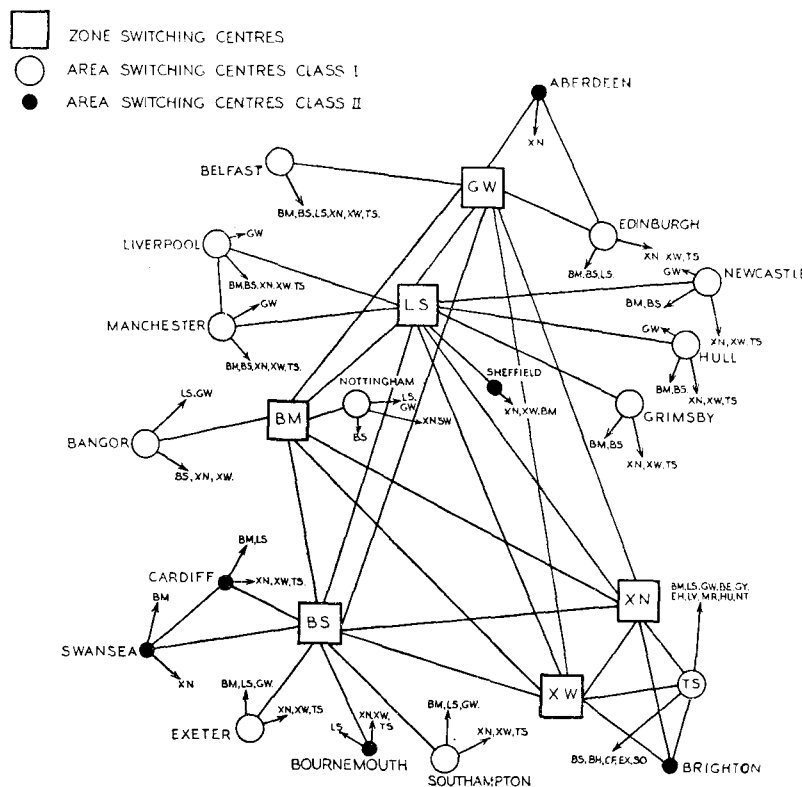

FIG. 2.—TELEPRINTER AUTOMATIC SWITCHING TRUNK NETWORK.

## 2.1 Transmission limits.

The layout arrangements above described and depicted schematically in Fig. 3, ensure that the maximum number of links in a switched connexion does not normally exceed either two VF channels plus two physical station lines of not more than 10 per cent. distortion, or three VF channels plus two physical station lines of negligible distortion.

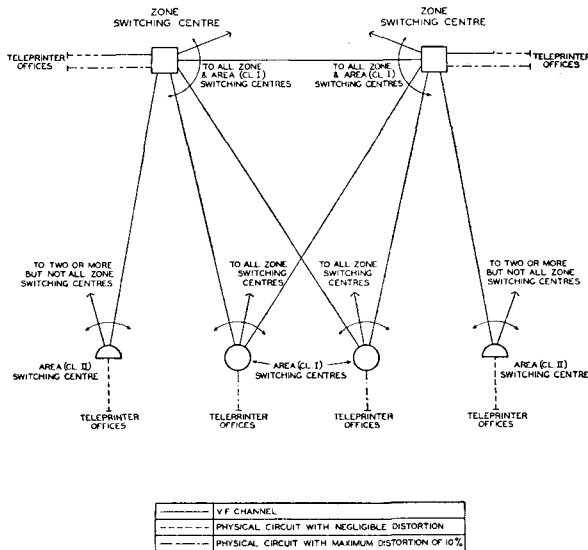

FIG. 3.—APPLICATION OF TRANSMISSION LIMITS.

These limits have been adopted to provide the required high degree of accuracy in the transmission of teleprinter signals under normal routing arrangements, whilst allowing ample margin for reception with alternative routing of traffic under emergency or breakdown conditions.

The limiting lengths of physical line which may be employed to meet the permissible distortion limits for station line circuits are shown in Table I. The figures quoted are equally applicable for 10, 20 or

TABLE I.  
Limiting distances for physical station line circuits routed in 10, 20 or 40lb star quad, twin or multiple twin cable.

Method of working employed	Maximum length of line (miles)	
	10% distortion	Negligible distortion
2-wire simplex non-relayed	20 (Note 2)	10
2-wire simplex relayed	45	20
2-loop simplex relayed	>90	>90

NOTE 1. The limits quoted for twin and multiple twin cables apply to side and phantom circuits.

NOTE 2. This figure would be 23 miles but for the requirement that when two physical lines are switched together the total cumulative distortion should not exceed 25%.

40lb conductor, as the signal distortion is due almost entirely to capacity coupling between adjacent conductors and is practically independent of conductor weight. Tests on 40lb or 70lb screened conductors

showed that the distortion was negligible up to distances greater than those likely to be encountered under automatic switching conditions, and limiting figures are not, therefore, quoted.

When, by application of these limits, teleprinter offices cannot be connected to their nearest switching centre by physical circuits of appropriate type, it will be necessary to connect them by VF channels to a zone switching centre, although it should be noted that in many cases connexion by VF channels has been employed for economic reasons. Fig. 4 shows the resulting network of VF station lines connected to zone switching centres.

Most of the distortion arising in a physical telegraph circuit is due to interference from other telegraph circuits working in the same quad. With duplex working between teleprinter offices, the possibility of three interfering circuits in one quad has to be allowed for, but under automatic switching conditions teleprinter transmission will normally be in one direction only, thereby restricting the potential number of interfering circuits in a quad to one, and the line limits given in Table I are based on this assumption.

The occasional setting up of switched duplex circuits (para. 3.6 refers) to deal with heavy concentration of traffic will normally be from a switching centre to a dependent teleprinter office, involving only one link in the connexion, and the limits adopted do not require to be modified on this account.

## 2.2 Resistance limits — physical station line circuits.

To cater for the "out-of-service" facility from teleprinter offices served by physical station lines, special circuit arrangements have been employed for both the non-relayed and relayed line terminations, which necessitate that the leg resistance of the physical circuit concerned should be limited to 1,060 ohms and 3,500 ohms respectively. These values are the equivalent of 12, 40 and 20 route miles of 10lbs conductor for non-relayed, 2-wire relayed, and 2-loop relayed circuits respectively, the limits for 20lbs conductor being, of course, double these values, and so on.

Having regard to the normal standards for the provision of medium to long physical line circuits, it is unlikely that the line limits imposed by resistance considerations will often be restrictive.

## 2.3 Impulsing limits.

Rigorous and extensive tests have shown that the impulsing arrangements adopted to operate the 2,000 type selectors employed in the system will function satisfactorily with all factors simultaneously adverse, up to the maximum number of links stipulated in paragraph 2.1.

## 2.4 Possible use of regenerative repeaters

On account of their geographical position relative to the main switching network it may not be possible to connect a small number of remote teleprinter offices to the switching system in accordance with the provisions of para. 2.1. Such offices would either

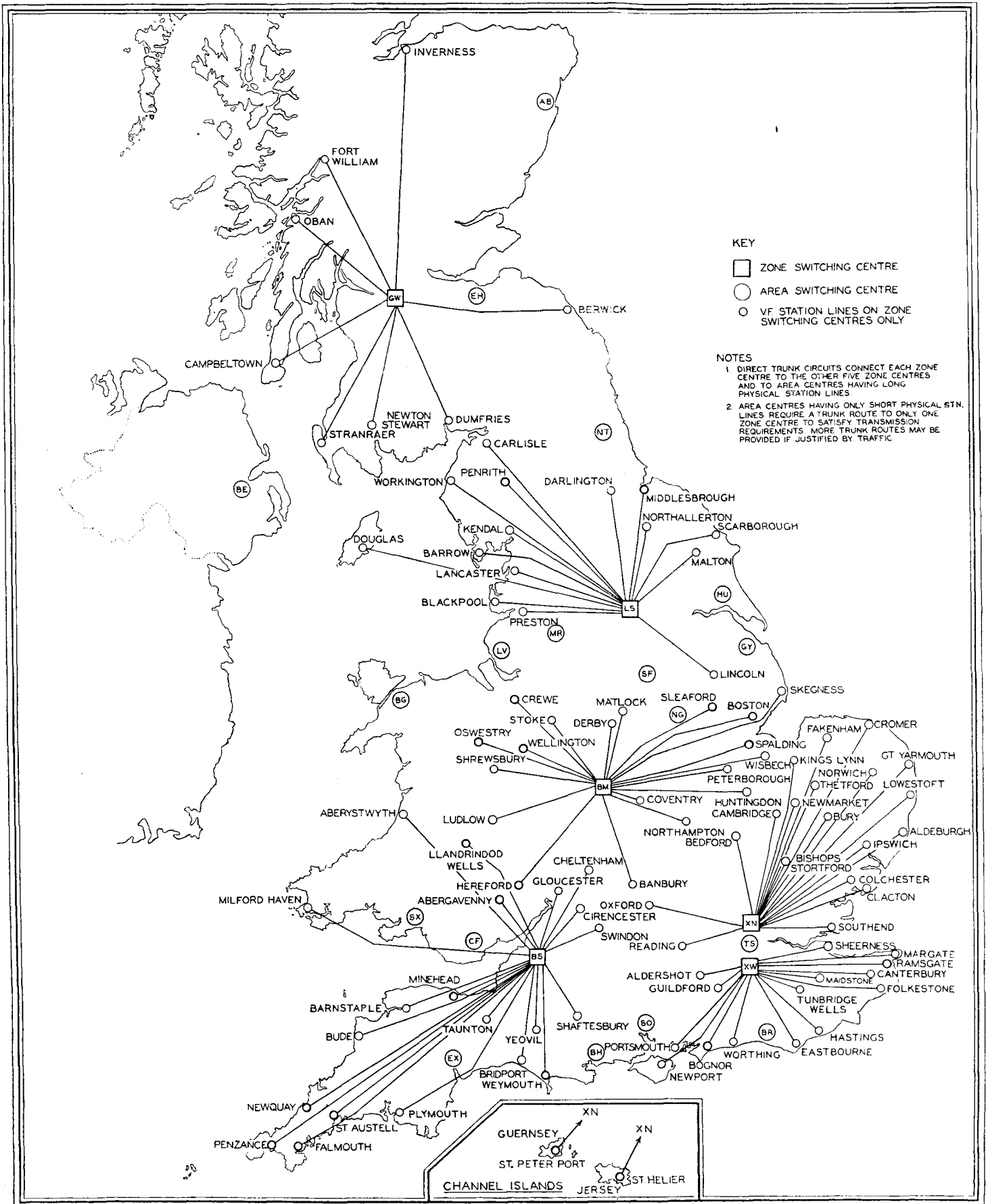

FIG. 4.—TELEPRINTER STATIONS CONNECTED VIA V.F. CHANNELS.



be excluded from the network, messages being re-transmitted, or alternatively connected to the network but restricted in some degree as to the offices to which direct dialling access could be obtained. The development of electronic regenerative repeaters of a type suitable to meet the requirements of the switching system has, however, reached a forward stage, and their possible application to the network, including the case of remote teleprinter offices, is receiving attention.

### 3. LINE AND SWITCHING PLANT—BASIS OF PROVISION.

The proportion of the cost of a telegram represented by the plant used to carry the signals is very small. Hence cost economies must be achieved by reducing staff costs, even if some increase in plant costs is necessitated. The introduction of automatic switching and consequent elimination of re-transmission at intermediate points will clearly reduce staff costs materially, but these savings would be largely offset if due to insufficiency of plant a number of repeated attempts had to be made to dial a call to completion. Further, the anticipated reduction in the transit times of telegrams would not be realised.

These factors have received full consideration during the development of the switching system, and as a result some novel facilities have been incorporated in the switching equipment, notably the provision of delayed hunting (or suspense) conditions on calls offered to the small groups of station line circuits, should all lines in the required group be engaged, coupled with facilities whereby the call is overflowed to the area office teleprinters at the switching centre concerned should a line in the group not become free within a period of 30—60 seconds.

The agreed basis of provision for lines and switching plant is stated in detail below. A common factor which should be noted, however, is that in applying the traffic tables to determine the actual plant provision the busy-hour traffic at times of peak-season load, *e.g.*, Christmas or other holiday period, is taken as the criterion, from which it follows that for by far the greatest proportion of the time the actual grade of service would be considerably better than the figures quoted.

The duration of each message or call is of obvious importance in determining traffic quantities, and observation on this factor during the pre-war grade of service tests resulted in figures of 62.5 seconds for

originated calls and 50 seconds for received calls, as an average of 10,171 messages transmitted. A figure of 60 seconds holding time for all calls has been adopted for design purposes.

#### 3.1 Teleprinter trunk circuits.

These, the main trunk circuits interconnecting the switching centres, will be provided to give a grade of service of .002 (1 lost call in 500).

The trunk circuits will be routed from the levels of 200 outlet group selectors, and will be provided on a bothway basis up to a maximum of 20 lines—the limit for full availability conditions. Routes in excess of this size will be divided into incoming, outgoing and bothway components, gradings being employed where necessary.

The standard traffic capacity table employed is reproduced in Table 2, showing interpolated the number of messages equivalent to the stated T.U. value for a holding time of 60 seconds.

#### 3.2 Lines to teleprinter offices.

The station line circuits which interconnect teleprinter offices with the switching centre equipment, are routed for outgoing traffic from the contacts of a 200 outlet final selector, which provides group hunting facilities on groups of 2—20 lines. Routes of up to 20 lines will be provided on a bothway basis, above which division into unidirectional and bothway circuits would be arranged. Requirements in excess of those which can be given with full availability are not anticipated.

The inefficiency of small groups of circuits in carrying automatically switched traffic with a reasonable grade of service is well known. The delayed hunting facility incorporated in the final selector, however, provides for a marked improvement in this respect, serving also to reduce the percentage of traffic overflowed to the area office teleprinters.

The special traffic table giving the agreed basis of provision is reproduced in Table 3, columns 1—3. Columns 4 and 5 show the estimated percentage of messages “delayed” and “overflowed”, and column 6 the average delay incurred by delayed messages. The figures as a whole take into account that the delayed hunting (or suspense) facility allows for 1 waiting call on groups of 1—4 circuits, and 2 waiting calls on groups of 5 or more circuits, any excess calls above these figures being routed without delay to the overflow teleprinter positions.

TABLE 2.—BASIS OF PROVISION OF TELEPRINTER TRUNK CIRCUITS (GRADE OF SERVICE 1 IN 500).

No. of Trunks	Traffic Units	No. of Messages	No. of Trunks	Traffic Units	No. of Messages	No. of Trunks	Traffic Units	No. of Messages	No. of Trunks	Traffic Units	No. of Messages
1	.002	—	11	4.02	241	21	10.70	642	31	16.95	1017
2	.065	4	12	4.63	278	22	11.32	679	32	17.57	1054
3	.25	15	13	5.27	316	23	11.95	717	33	18.20	1092
4	.53	32	14	5.92	355	24	12.57	754	34	18.82	1129
5	.90	54	15	6.58	395	25	13.20	792	35	19.45	1167
6	1.32	79	16	7.26	436	26	13.82	829	36	20.07	1204
7	1.80	108	17	7.95	477	27	14.45	867	37	20.70	1242
8	2.31	139	18	8.64	518	28	15.07	904	38	21.32	1279
9	2.85	171	19	9.35	561	29	15.70	942	39	21.95	1317
10	3.43	206	20	10.07	604	30	16.32	979	40	22.57	1354

NOTE.—Grading with availability of 20 assumed on trunk routes of 21—40 circuits.

TABLE 3.—BASIS OF PROVISION OF STATION LINES.

No. of Lines	Traffic Units	No. of Messages	Estimated %age of messages		Estimated delay on delayed calls (Secs.)	No. of Lines	Traffic Units	No. of Messages	Estimated %age of messages		Estimated delay on delayed calls (Secs.)
			Overflowed (Note 2)	Delayed					Overflowed (Note 2)	Delayed	
1	.30	18	8.4	21.6	34	11	6.00	360	1.0		
2	.70	42	4.7	13.3	26	12	6.60	396			
3	1.15	69	4.0	9.0	15	13	7.30	438	1.0		
4	1.65	99	2.2	7.8	12	14	8.00	480			
5	2.33	140	2.1	6.1	9	15	8.80	528			
6	2.94	176				16	9.60	576	1.0		
7	3.60	216	1.5	4.5	5	17					
8	4.30	258	1.35			18					
9	4.80	288				19					
10	5.40	324	1.1	2.9	3	20					

NOTE 1.—Assumes provision for 1 "waiting" call on groups of 1—4 lines; and for 2 "waiting" calls on groups of 5—20 lines.

NOTE 2.—In practice these figures are halved, the other half being in the form of delay to traffic originated at the teleprinter end of the line.

It will be noted that so far no specific reference has been given to the grade of service provided by this Table. From the viewpoint of the disposal of traffic from the originating office, an "overflowed" call is a completed transaction, and no further dialling attempts have to be made. Hence the grade of service can be regarded effectively as that provided for the outlets to the overflow teleprinter positions, *i.e.*, 1 in 500 (para. 3.3 refers), since this is the only point at which an engaged condition can be encountered when a call has reached the final selection stage. Alternatively, from the overall service viewpoint, overflowed calls have to be retransmitted from the area office, where they are received, to the objective teleprinter office, and hence the number of such transactions becomes the measure of the service provided. By this criterion, the grade of service for a single circuit office is 1 in 25, for a 5 circuit group 1 in 97, and for a 10 circuit group, 1 in 166. These figures do not, however, take into account the weighting effect of the varying numbers and sizes of the groups of circuits connected to a switching centre. A more effective method of demonstrating the effect of applying the above standards can be obtained by considering the aggregate effect at a typical zone switching centre, under average traffic conditions, for which it has been estimated that of the total of 1964 calls offered in the busy hour to its various groups of station lines, 26 (1.3%) would be overflowed and 78 (4%) would be delayed. The estimated increase in the duration per call due to the suspense facility would be 0.65 seconds.

Finally, as regards all the above figures, it should be noted that these assume all traffic to be offered from the switching equipment to the teleprinter office. In practice such circuits will carry traffic in both directions, and hence the percentages of calls suspended and overflowed would be half that quoted, the other half being in the form of delay to originated traffic at the teleprinter end of the circuit.

### 3.3 Zone or area office teleprinters.

To keep dialling time to a minimum, and to economise in switching plant, the circuits to the teleprinters in the instrument room associated with

each switching centre will be routed from a first selector level, and provided to give a grade of service of 1 in 500. For these circuits the cost of line provision is not a determining factor, as the instrument room will normally be located in the same building as the switching equipment.

In addition to handling the normal area office traffic, originating and received, the overflow traffic from all station line circuits served from Final Selector Units at the switching centre will be routed at most offices to the same common group of teleprinters, and will thus be afforded the same grade of service. Where the aggregate amount of overflow traffic is sufficient, however, to justify the provision of a separate group of "overflow" teleprinters at the area office, this arrangement will be adopted, initially in order to facilitate the subsequent retransmission of the messages, and ultimately to simplify the probable application of printing reperforators and auto-transmitters for the storage and retransmission of this traffic.

### 3.4 Switching equipment.

Switching equipment will be provided to give a grade of service of .001 (1 lost call in 1,000).

### 3.5 Point-to-point teleprinter circuits.

Circuits connecting together two offices having a sufficient quantity of direct traffic to justify their retention will continue to be provided. Such circuits will continue to be operated on a duplex basis.

In this connexion it is of interest to note that such is the diversity of traffic distribution in the inland network that the total estimated number of direct point-to-point circuits which will be retained after the completion of the automatisisation programme is 15, comprised of single circuits from 15 provincial offices, all of which will terminate at the Central Telegraph Office, London.

### 3.6 Duplex positions.

To facilitate the disposal of traffic accumulated due to breakdown conditions, or of heavy traffic due to emergency conditions or unpredictable local events, a separate group of duplex teleprinter positions will

be provided at each area office, to which access may be gained by dialling a special final selector number. Suspense and overflow facilities are not required on these circuits and will not be provided. At least one duplex position will also be provided at each teleprinter office handling traffic in both directions.

These arrangements will enable emergency point-to-point duplex circuits to be set up over the switching network, which may be used continuously for the "overload" period. From a technical viewpoint the duplex positions will be identical with the normal teleprinter positions, but will have physical dimensions of 5ft. 6in. compared with the normal 4ft. 6in. or 4ft. 9in.

### 3.7 Enquiry positions.

A separate group of enquiry teleprinter positions, to deal with RQ and similar traffic will be provided at each switching centre, access being gained by dialling a special final selector number without suspense or overflow facilities.

### 3.8 Grade of service tests.

The probable effects of traffic overloads on both trunk and station lines were given careful consideration when establishing the standards to be used. The estimates were subsequently verified by a series of traffic trials using the pre-war experimental switching equipment, during which some 3,000 dummy messages and 10,000 live messages were transmitted. The amount of overflow traffic was found, in general, to be less than estimated, for both normal and overload conditions up to 100%. The value of the suspense facility was also confirmed, particularly during a 500% overload test to a 2-circuit teleprinter office, during which it was also noted that no difficulty was experienced at the small office concerned in originating calls against the overload condition.

The conclusions drawn as a result of these trials are equally applicable to the post-war scheme, since the traffic facilities involved have remained virtually unchanged.

### 3.9 Traffic recording.

To enable the grade of service to be maintained, both on the automatic switching equipment, and the groups of trunk circuits, standard BPO type automatic traffic recorders will be provided at all switching centres. Overflow meters will also be provided where applicable.

## 4. TRUNKING ARRANGEMENTS.

### 4.1 Area numbering scheme.

To meet the specific requirements of the Public Telegraph Service, a direct dialling system, without storage or translation facilities has been adopted. Consequently, to ensure the most economical usage of line plant and switching equipment, and to keep the number of dialled digits to a minimum, an area numbering scheme will be employed. Thus the number to be dialled to reach a given office will depend on the area in which the originating office is situated.

Nevertheless a common "directory" will be issued for the country as a whole, this being made possible by the use of a mixed letter and figure code to designate each office, *e.g.*, BM531, where the letters

are the telegraph code of the parent switching centre, and the numerals represent the number allocated to the office concerned at this centre. To determine the complete number to be dialled at any originating teleprinter position, the operator would ascertain the numerical equivalent of the letter designation (*e.g.*, 12 for BM) from the dialling code list displayed on the front of the dialling unit, the resultant number to be dialled being 12-531. It should be noted that the identifying code BM531 will normally be inserted on a telegram at the circulation positions in the originating office before being passed to the forwarding teleprinter operator for transmission.

The adoption of an area numbering scheme, coupled with the circulation arrangements above described, will enable the alternative routing of traffic under prescribed conditions to be readily effected, it being necessary only to show the alternative dialling code for each switching centre, and not for each office.

A schematic diagram which illustrates the routing of typical calls over the network, is given in Fig. 5. From 1 to 7 digits may be necessary to establish a call although the weighted average will be of the order of 4 digits. The numerical value of the digits dialled, as well as the number of digits, affects the time taken to dial a call, and hence consideration has been given to the traffic loading in allocating the selector levels at each switching centre, in order to keep the dialling time to a minimum.

### 4.2 Typical trunking arrangements.

A skeleton trunking diagram for a typical small area switching centre (Bournemouth) is given in Fig. 6, from which it will be seen that a 3 digit numbering scheme is employed for the groups of station lines from the final selector unit, access to other switching centres being from the levels of first selectors, *i.e.*, a single digit dialling code. Level "0" of the first selector is used to give direct dialling access to the area office teleprinters associated with the switching centre, while the overflow level (level 1) of the final selector is tied to the same outlets in order to route the overflow traffic to the area office teleprinters. Level 9 of the first selector is reserved for possible use in connexion with the projected revised Telex service, and level 1 used for access to a separate rank of special services final selectors, the purpose of which is described later.

The trunking arrangements at all other switching centres will conform to the same general principles, excepting that with increase in size of the centres concerned, and also of their classification, the provision of second numerical selectors and of additional final selector ranks becomes necessary. The limit of such arrangements without recourse to a 4 digit numbering scheme is typified in Fig. 7, which shows the ultimate arrangements for the Birmingham zone switching centre, where all dialling codes are of two digits. It will also be noted that the overflow level of the final selectors is shown routed direct to a separate group of teleprinters situated in the zone office, for the reasons previously stated in para. 3.3. Exceptionally, in the London zone switching centres, London West (XW) and London North (XN), a 4 digit, and a mixed 3 and 4 digit numbering scheme respectively, will be employed.

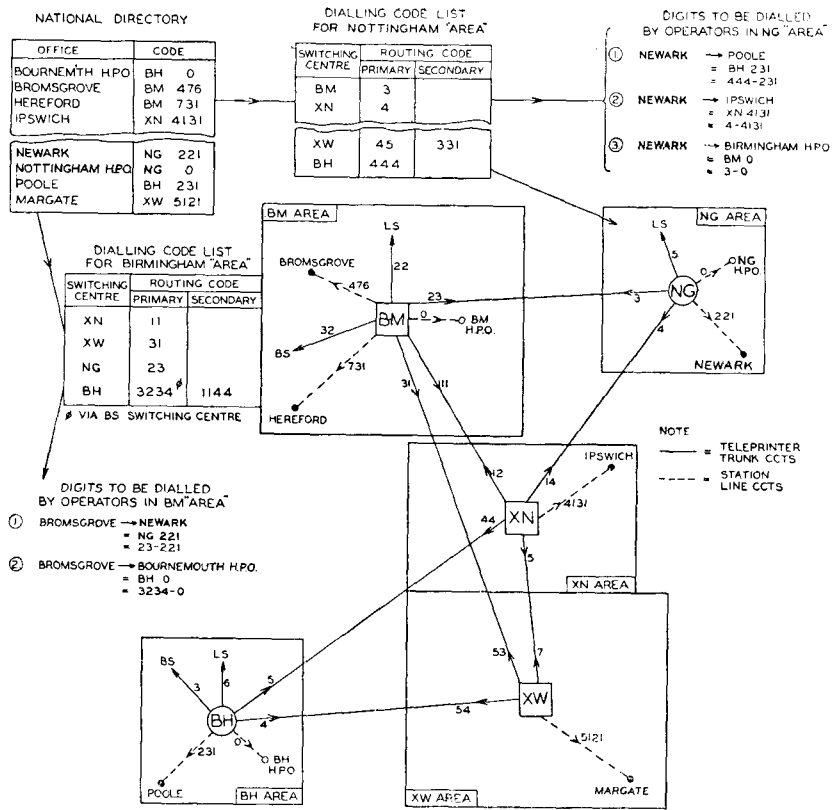

FIG. 5.—AREA NUMBERING SCHEME—TYPICAL ROUTING OF CALLS.

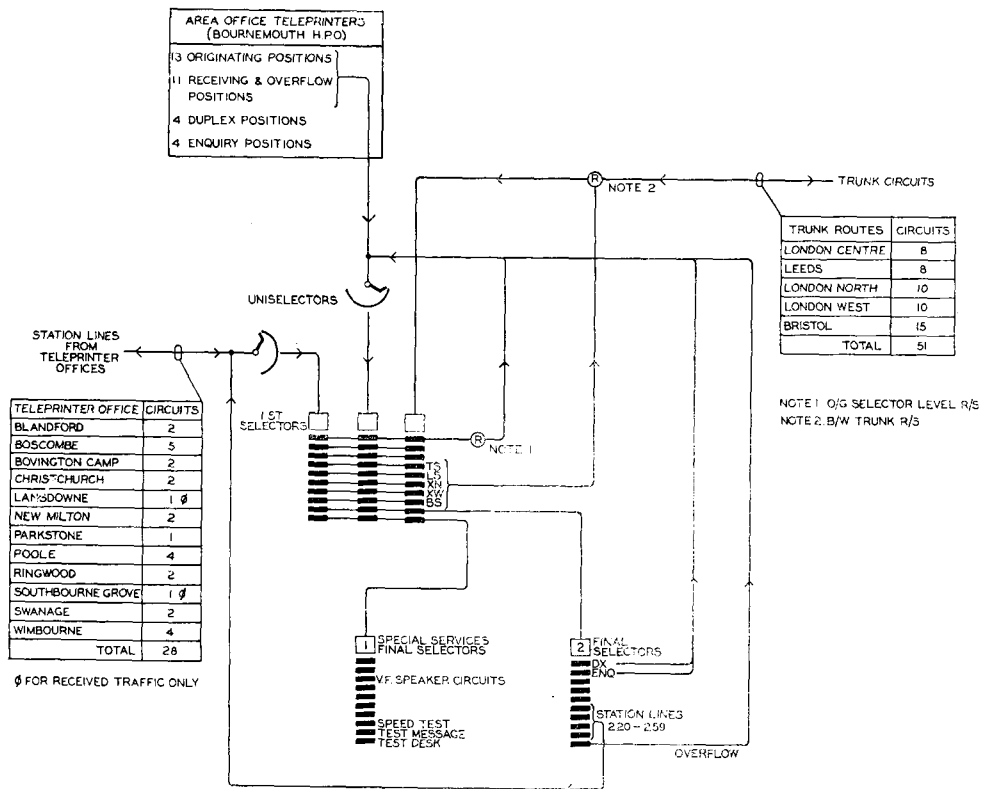

FIG. 6.—SKELETON TRUNKING DIAGRAM OF TYPICAL AREA SWITCHING CENTRE (CLASS II).

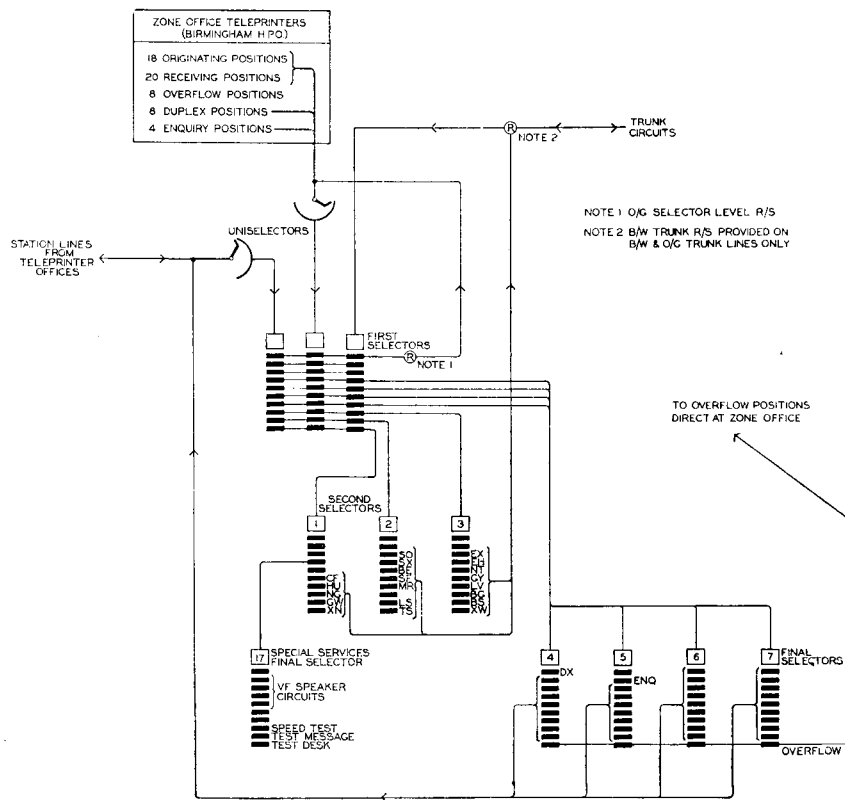

FIG. 7.—SKELETON TRUNKING DIAGRAM OF TYPICAL ZONE SWITCHING CENTRE (BIRMINGHAM).

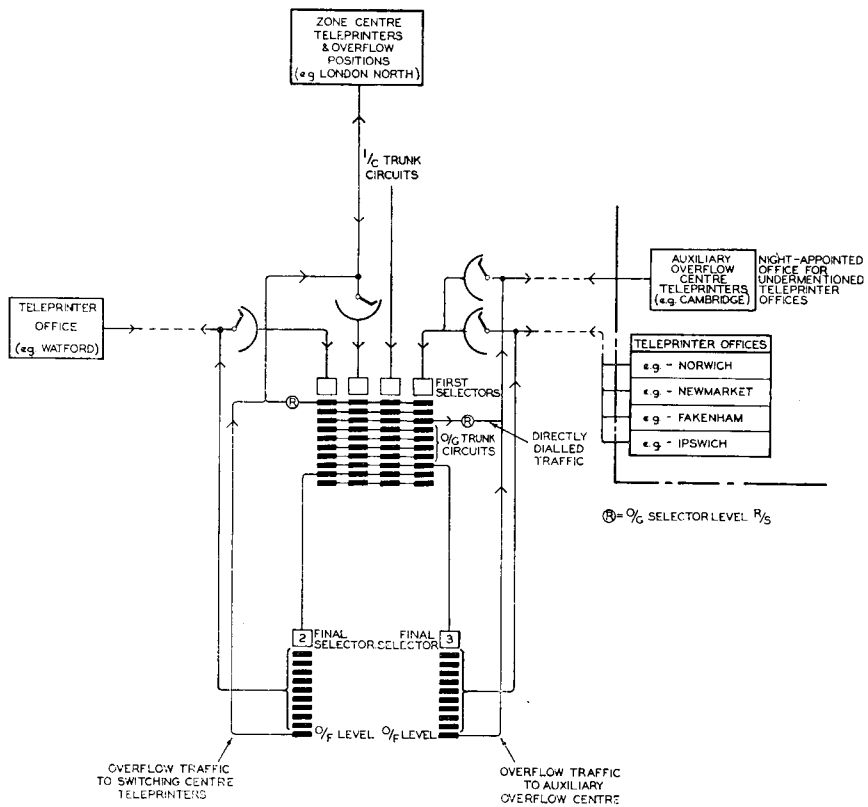

FIG. 8.—SCHEMATIC TRUNKING ARRANGEMENTS FOR AUXILIARY OVERFLOW CENTRES

### 4.3 Night service arrangements.

Generally the zone or area office functions also as the night-appointed office for the switching area. Calls are always dialled to the destination office, and are overflowed to the area office without delay if the destination office is closed. In this way the use of night service codes is avoided and the closing time of offices can be varied without prior notice.

Where these arrangements do not meet traffic requirements, either auxiliary overflow centres as described below will be employed, or special night dialling codes will be used.

### 4.4 Auxiliary overflow centres.

Certain offices which are not switching centres, but which are well situated to act as a "night-appointed office" for the smaller offices in their geographical area, have been designated as auxiliary overflow centres. These centres will handle overflow traffic from their associated smaller offices at all times, including night traffic which will be overflowed without delay when an office is closed down. Typical centres are Cambridge and Canterbury.

From Fig. 8, it will be seen that by providing a separate rank of final selectors to serve the teleprinter

offices in the designated area, the overflow traffic from these offices may be segregated from the switching centre overflow traffic, and connected to the outlets serving the auxiliary overflow centre. The normal arrangements will be to allocate a 2 digit dialling code to give direct access to such centres—the circuits being provided to give a grade of service of 1 in 500—the overflow level of the final selector rank concerned being teed to the allocated second selector level. Exceptionally, where the total traffic is small, the overflow level of the final selector rank may be allocated as the number of the auxiliary overflow centre, thereby automatically ensuring that overflow traffic from all other offices served by the final selector unit is routed to this centre.

The first-mentioned arrangement is also applied to the London ring offices not associated with switching centres, *i.e.*, London East (XE), which is connected to the London North zone switching centre, and London South (XS) connected to the London West zone switching centre. The simplified trunking diagram for this latter centre (Fig. 9) clearly illustrates the effect of providing such facilities on the trunking arrangements for a zone switching centre.

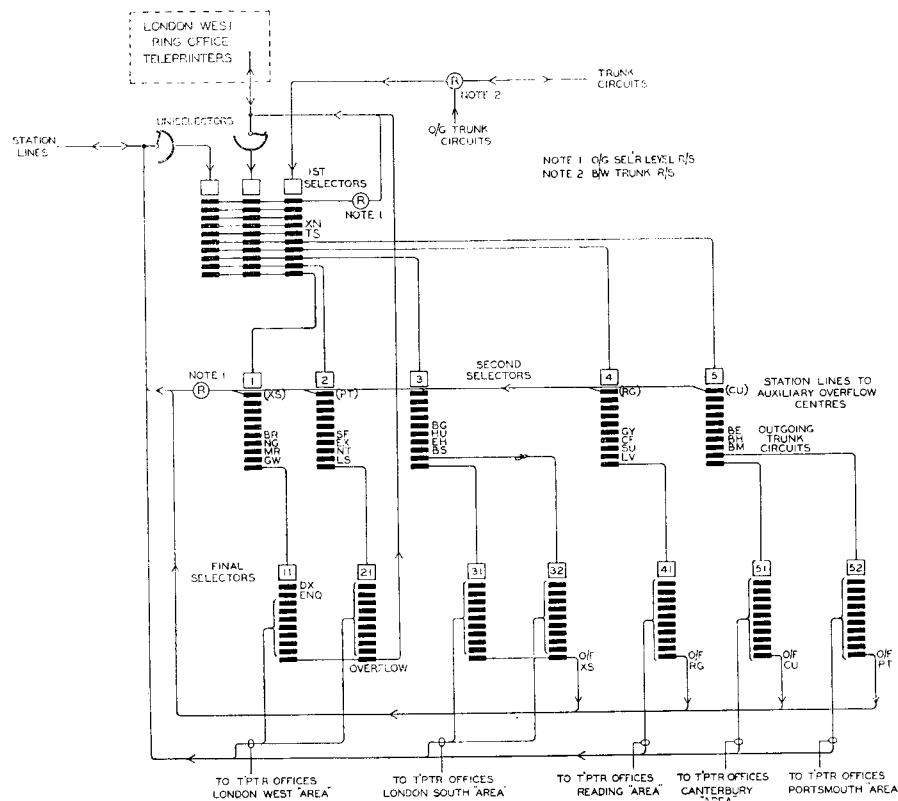

FIG. 9.—SKELETON TRUNKING DIAGRAM—LONDON WEST ZONE SWITCHING CENTRE.

#### 4.5 Arrangements for bothway circuits.

The use of bothway trunk circuits provides a special problem, since on seizure of a circuit it is not possible to guard against the intrusion of a call in the reverse direction for the transit time of the calling signal over the line, plus the time required to operate the guarding relay at the distant end. Although the operate time of the guard relay has been kept at less than 1 mS, the transit time of the calling signal over a VF channel may be appreciable, being composed of a constant delay of 40 mS due to the filter-networks in the MCVF equipment, plus a variable delay governed by the route mileage and characteristics of the line employed, which could also approach 40 mS for a long heavily loaded audio circuit.

To assess the probability of simultaneous connexions arising, calculations have shown that for a group of 20 bothway circuits the figures are 1 in 56 for a 100 mS delay period, and 1 in 150 for a 40 mS delay, assuming that the traffic is equally divided and offered in the same order to the circuits at either end. By reversing the order of testing as between the two ends, however, the probability of simultaneous connexions is reduced to the order of 1 in 10,000.

Although there is no possibility of losing messages due to simultaneous connexions, confusion would undoubtedly arise, as well as delay in the transmission of telegrams, and for these reasons bothway trunk circuits will be reversed in their order of connexion to selector outlets at the two ends, not only on wholly bothway routes, but also for routes divided into unidirectional and bothway components, where the unidirectional circuits should be arranged as the early choice outlets at either end.

To minimise the possibility of simultaneous connexions on station lines working on a bothway basis, it will be arranged that messages originating at the

teleprinter offices will be so distributed to teleprinter positions for forwarding, as to be offered effectively to the station line circuits in the reverse order to the order of testing at the switching centre.

#### 5. CONVERSION PROGRAMME.

The conversion of the existing network to automatic working will proceed by stages, the policy being to complete the installation of the zone switching centres as early as practicable, as will be seen from the installation programme given in Table 4.

For the initial phase of the scheme, which will partake also of the nature of a large scale field trial, London North and Birmingham zone switching centres will be opened for service, with switching equipment provided on a limited scale to carry only about 10% of the traffic these centres will ultimately handle. At all other stages, however, the automatic equipment installed initially at the switching centres will be provided to meet ultimate requirements, since the conversion programme has been planned for completion by Autumn, 1952.

The detail planning of the conversion programme has, to a large extent, been governed by the adoption of the Teleprinter No. 11B for use in the automatic system (para. 6(1) refers), since the possibility of interworking between the automatic network and the existing teleprinter manual switching scheme using the Teleprinter No. 3 has thereby been precluded, due to differences in the speed and code allocations of the two instruments. Other factors, such as availability of accommodation, and of staff training, coupled with the usage of two different teleprinter keyboards during the conversion period, have also required due consideration to be given them, details of which are beyond the scope of the present paper.

TABLE 4.—INSTALLATION PROGRAMME FOR SWITCHING CENTRE EQUIPMENT.

Stage	Target Date	Zone Switching Centres	Area Switching Centres Class I	Area Switching Centres Class II
1	Spring 1950	Birmingham London North		
2	Spring 1951	Bristol Leeds Glasgow	London Centre Manchester Exeter Newcastle Nottingham	
3	Autumn 1951 to Spring 1952	London West	Edinburgh Grimsby Hull Liverpool	Cardiff Sheffield Swansea
4	Autumn 1952		Bangor Belfast Southampton	Aberdeen Bournemouth Brighton

## 6. TELEPRINTER POSITION EQUIPMENT.

The main functional items of equipment concerned are the teleprinter, and the dialling unit. At large offices these items will be mounted on a continuous bench, and power supplies for driving the teleprinter motor and for signalling purposes, will be obtained from 80 + 80V batteries. At smaller offices, however, up to say 8 positions, a new design of unit table is to be installed, which, owing to its special shape, should facilitate the layout of the positions, and also ease the accommodation problem, as all engineering equipment is contained within the table unit. Fig. 10 illustrates the "L" shaped table, and shows also the teleprinter, dialling unit and rectifiers for providing the signalling and motor supplies. To provide easy access for maintenance, the chassis on which the rectifiers mount can be pulled forward from below the table top.



FIG. 10. UNIT TABLE EQUIPMENT.

### 6.1 The Teleprinter No. 11B.

The Teleprinter No. 11B (Fig. 11), which will replace the existing teleprinter No. 3 as the changeover to automatic switching proceeds, is a new design of tape-printing teleprinter, which conforms to CCIT recommendations as regards speed (50 bauds) and code (International Alphabet No. 2), and incorporates a 20 character answer-back unit.

The more notable features of the new design are :—

- (a) Ribbon inking.
- (b) External paper mounting, paper feed and printing mechanism.
- (c) Paper failure alarm contacts integral with the machine.
- (d) Receiving cam orientation device.
- (e) Improved type-head clutch.
- (f) Positive operation of the keyboard combination bars by the key levers, using "saw-tooth" principle.
- (g) "Run-out" key for obtaining repetitions of any desired character.
- (h) "Here-is" key for tripping the answer-back unit locally.
- (i) Improved type face.



FIG. 11. TELEPRINTER NO. 11B AND DIALLING UNIT.

### 6.2 The dialling unit.

The dialling unit (Fig. 11) is a self-contained item, mounting the dial, three supervisory lamps, and six keys. The case of the unit, which has been made of sufficient height to enable the main supervisory lamps to be seen readily from a distance, also contains the switching relays (accommodated on a jacked-in relay set to facilitate maintenance), the motor start-stop relay, and other components. The functions of these various items will be covered in following sections.

## 7. OPERATING FACILITIES AND SERVICE SIGNALS.

The major facilities provided from an operating viewpoint are summarised below :—

*Outgoing calls.* The sending operator depresses the dial key. When a free first selector has been seized the white opal dial lamp glows, and the teleprinter motor starts. The operator then dials the required number, and establishment of the connexion is indicated by the automatic return of the answer-back signal from the distant teleprinter, preceded by the darkening of the dial lamp and the lighting of the green supervisory lamp at the top of the dialling unit. After transmission of the message, and final depression of the teleprinter WRU key by the sending operator to obtain the answer-back signal, the connexion is cleared by depression of the clear key.

*Incoming calls.* A call received at a teleprinter position will be indicated by the lighting of the green supervisory lamp; the teleprinter motor is also started. The lamp will continue to glow (to call attention to a message awaiting collection) after the call has been cleared, until the reset key is operated.

The teleprinter motor stops upon the receipt of the clearing signal, but the position is free to receive further incoming calls without prior operation of the reset key.

An incoming call may be released—in exceptional circumstances—by depression of the clear key, as either party release facilities are incorporated in the system.



*Paper failure alarm.* In the event of the paper failure contacts operating, due to paper exhaustion, paper breakage or failure to feed, the established connexion is automatically released in its entirety, and, at the position where the paper failure occurred a red paper alarm lamp at the top of the dialling unit flashes, while an audible alarm is also operated in the instrument room. Operation of the alarm cut-off key silences the audible alarm and causes the red lamp to glow steadily, which persists until the failure is remedied and the alarm cut-off key restored to normal.

The faulty position is automatically rendered unavailable to further incoming calls until the fault condition is removed.

*Out-of-service condition.* By throwing the out-of-service key, a teleprinter position is busied against incoming calls, and the teleprinter connected for operation in local. The key will be operated either when it is desired to close a position for traffic reasons (e.g., when an office closes at night), or when it is faulty. In either event the position is restored to service by restoring the out-of-service key.

The remaining two keys of push-button type, mounted on the side of the dialling unit, i.e., the motor start and stop keys, are only operative when the out-of-service key is thrown, and permit the operation of the teleprinter in local for test purposes.

*Suspense facility and wait signal.* Calls to offices other than zone or area offices (i.e., the main instrument room associated with the switching centre) will be held in suspense if all the available circuits are engaged. At this stage the dial lamp is darkened, and the green supervisory lamp lights at the originating teleprinter position, and the wait signal is returned to the caller, being printed as the characters MOM—continuously repeated at 1.6 seconds intervals.

As soon as a line in the required group becomes free, the first waiting call is switched to it, and the establishment of the connexion indicated by the automatic receipt of the answer-back signal from the called teleprinter.

*Overflow facility.* The suspense or waiting period is limited to 30—60 seconds, and should a line not become free in this time, the waiting call is automatically routed to a teleprinter position at the area office, the automatic answer-back signal from which is an indication to the sending operator to transmit the message, which would be re-transmitted later to the objective office.

Calls dialled to a teleprinter office where all lines and waiting contacts are engaged, are automatically overflowed as above without a suspense period or the return of the wait signal. Similarly, if all the lines in a group are out-of-service (e.g., office closed down for the night period) calls dialled to such a group are also overflowed without delay.

*Busy signals.* These signals are returned to the calling operator if the call encounters engaged conditions due to congestion of switching equipment or of line plant, as follows :—

NC, signifying “no circuits”, should all outlets to a group of selectors, or trunk circuits, be engaged.

OCC, signifying “occupied”, should all station lines to the required office, or its overflow centre, be engaged. It will be appreciated that due to the overflow facility, this signal can only be received when all the available zone or area office teleprinters are engaged.

The calling operator would release the connexion on receipt of either of these signals, and re-dial the call later.

*Out-of-order Signals.* These signals are returned to the calling operator in the event of the call being connected to a faulty trunk circuit or station line, as follows :—

DER T, denoting trunk line (or associated switching equipment) faulty.

DER S, denoting station line (or associated switching or teleprinter equipment) faulty.

The calling operator would release the connexion on receipt of either of these signals, and re-dial the call later. Should the second attempt also fail, an alternative routing code would be dialled, or other action taken, according to the operating instructions in force.

*Forced release.* If an operator depresses the dial key but fails to dial, the connexion will be completely released after a delay period of 12—24 seconds.

*Immediate release.* A connexion will be immediately and completely released when—

- (1) The call is routed to a spare level or unallocated final selector contact.
- (2) A “false clearing” signal occurs on an established connexion due to a line irregularity.

## 8. SWITCHING CENTRE EQUIPMENT.

### 8.1 General.

The adoption of a step-by-step switching system has the great advantage that the equipment will in the main consist of standard components as employed in automatic telephony, which will not only facilitate the provision of the switching equipment, but also give economy in equipment costs. Staff training and maintenance arrangements should also be simplified.

### 8.2 Relay sets and selectors.

The following basic items of switching equipment will be required for installation at the switching centres :—

Station line (Uniselector Circuits)	B/W trunk relay sets
Group selectors (200 outlet)	O/G selector level relay sets
Final selectors (200 outlet)	Special services final selectors and associated miscellaneous relay sets
Suspense relay sets	

2000 type 2-motion selectors, P.O. standard uni-selectors, 3000 type relays and high speed relays comprise the major standard components employed, together with a polarised relay of telegraph type, which is required on some of the units. These components will be seen in Fig. 12, which illustrates the final selector. The polarised relay which mounts in a normal 3000 type relay drilling, is the type 4 Carpenter, with a single changeover contact combination. Tests have shown that slight bias distortion

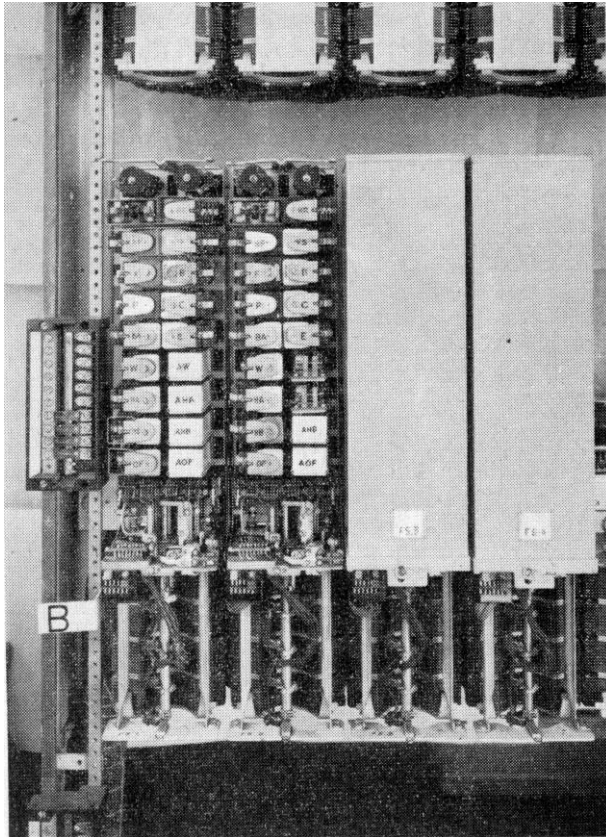

FIG. 12. FINAL SELECTOR.

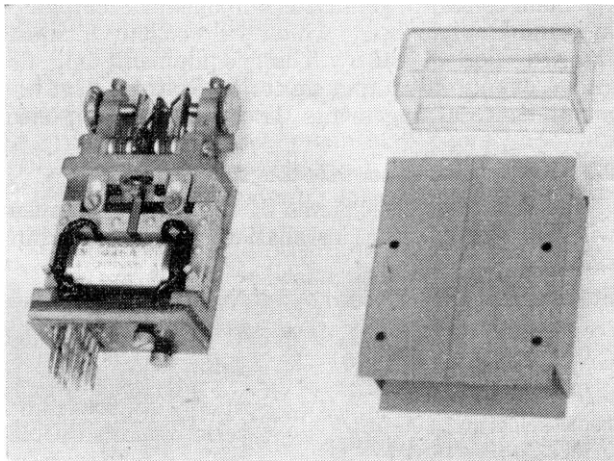

FIG. 13.—CARPENTER RELAY.

may be caused to an unscreened relay by the energisation of adjacent 3000 type relays, hence a fixed magnetic screen is employed, with detachable plastic front cover to facilitate maintenance adjustments. The relay, screen and plastic cover are shown separately in Fig. 13.

### 8.3 Racks and frames.

The general rack equipment arrangements will also conform to telephone practice, *e.g.*, jacked-in relay sets and selectors on 2000 type racks, with 50v. bus-bar type power distribution. Standard types of IDF and TDF will also be provided.

A difference from telephone practice lies, however, in the requirement for 80+80v. supplies to relay sets and selectors for signalling purposes, typical arrangements for which will be seen at the top of the final Selector rack shown in Fig. 14.

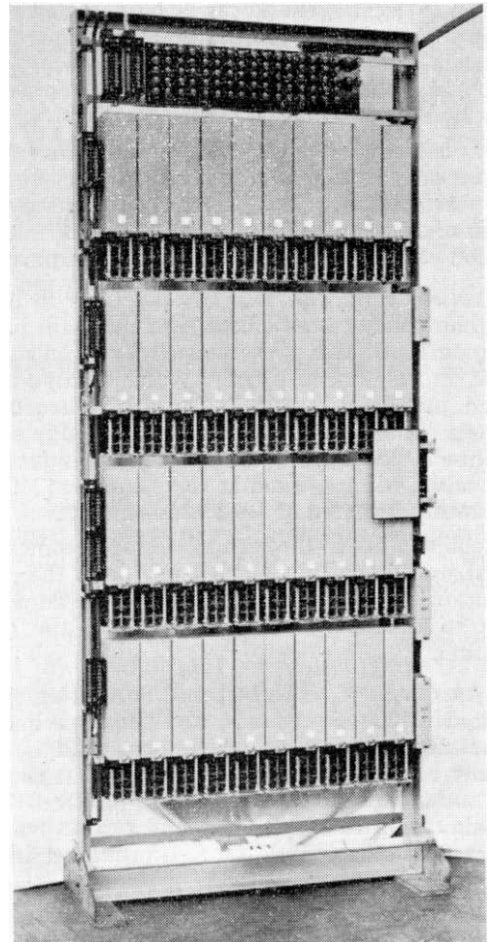

FIG. 14.—FINAL SELECTOR RACK.

### 8.4 Engineering control board

All station lines and trunk circuits will be connected to the switching equipment via the ECB, which is in the form of a trunk test rack, and provides full access to the lines for testing purposes. Cross connections by means of plugs and cords can also be effected on the ECB, and provision is made for plugging up faulty lines.

### 8.5 Signal generators and associated equipment.

To produce the service signals previously mentioned together with Who are You (WRU) signals for transmission to called stations, and teleprinter test messages with varying degrees of distortion, a series of three motor-driven signal generators has been developed and produced by the P.O. Fig. 15 shows a typical signal generator, the brush type distributor from which the  $7\frac{1}{2}$  unit teleprinter signals are derived, and the cam operated springs which provide for the making up of the required signal combinations, being clearly visible. The remaining cam operated springs provide the time pulses necessary for the proper functioning of the switching equipment, some of which require to be phased accurately in relation to other signals.

To provide the necessary accuracy of signal generation, the motor speed is governed at 3000 r.p.m. by a phase comparator circuit. The controlling voltage is derived by comparison of the phasing of a 50 c/s signal generated by the motor, with a standard 50 c/s signal from a valve maintained tuning fork.

Fig. 16 shows in schematic form the signal distribution arrangements from the generator to the switching equipment. The valve circuit employed for primary distribution has been incorporated to minimise wear at the distributor brushes and segments. The secondary distribution is via polarised telegraph type relays, spark quenching of the contacts being arranged as for telegraph broadcast relays.

Continuity of service from the signal generators will be as important in telegraph switching as the

ringing generator is in automatic telephony, hence a complete set of standby signal generators with automatic change-over facilities will be provided at all switching centres.

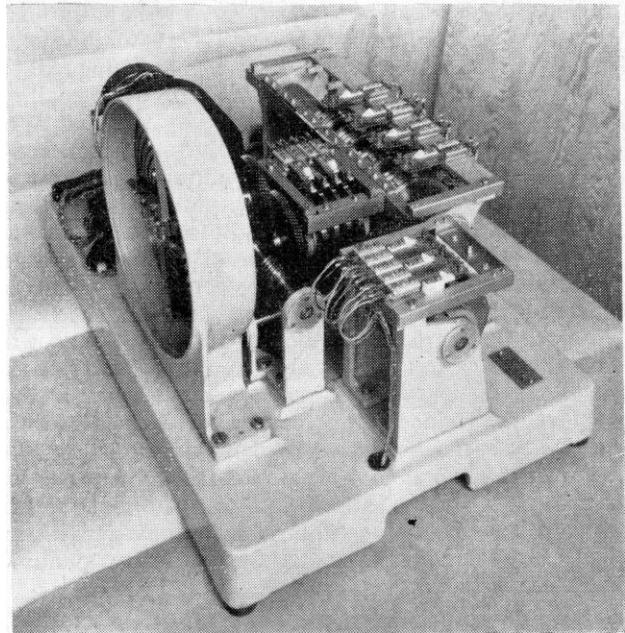

FIG. 15.—SIGNAL GENERATOR.

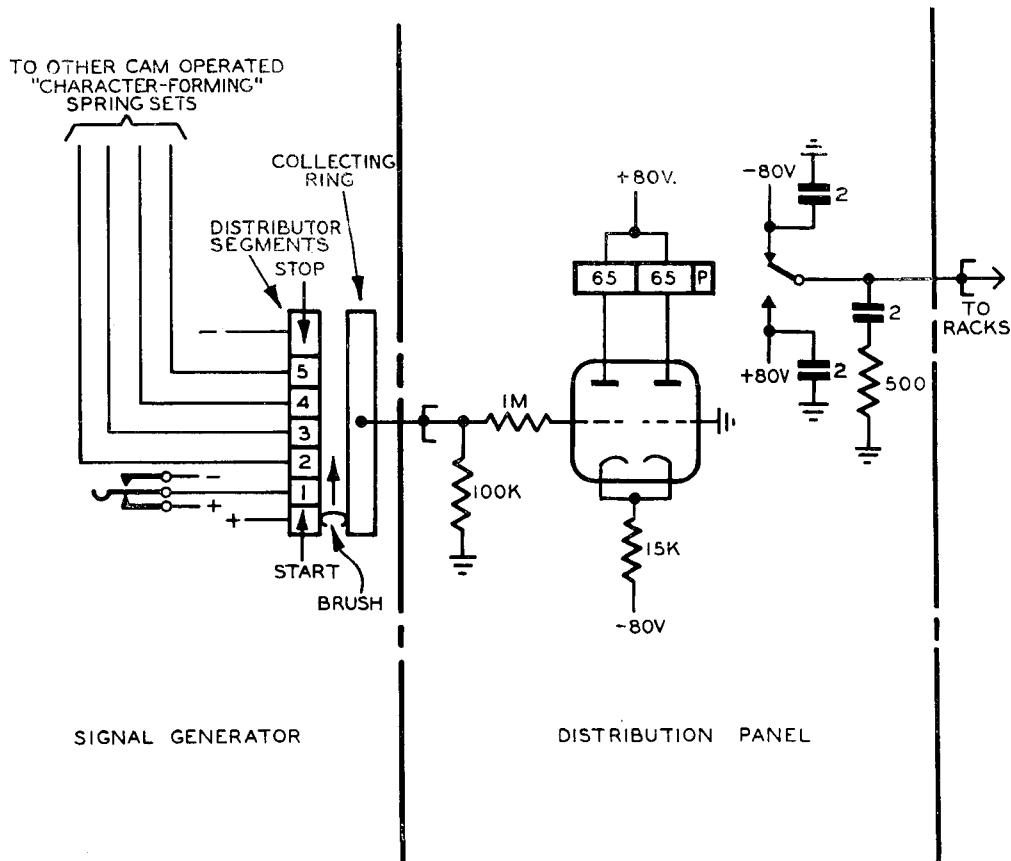

FIG. 16.—SIGNAL DISTRIBUTION ARRANGEMENTS.

## 9. SIGNALLING PRINCIPLES.

### 9.1 General

The teleprinter circuits will be provided on a bothway-simplex basis, and employ double-current line signalling from an 80+80v. power supply. The signalling system will conform to CCIT recommendations, the principle employed being that the line signalling conditions will be different for the disengaged and idle conditions, *i.e.*, spacing when disengaged and marking when idle. Thus the calling and clearing signals will be effected by the change of conditions from "spacing" (+80 v.) to "marking" (-80v.) and vice versa. Dialling impulses will also be double current, the "break" period of spacing current, and the "make" period of marking current.

Where MCVF equipment is used for the provision of circuits, the VF signals will be converted to double current working before passing to the switching equipment. Mark on the d.c. sections of a circuit will correspond to tone on the VF channel, and space to no-tone. Thus, when disengaged, a line fault will require to produce a tone condition to create a false seizure of the switching equipment, which will restore to normal when the false signal ceases. Conversely if a call in progress is interrupted for a sufficient period by a no-tone fault condition the whole connexion will be released immediately thereby avoiding undesirable secondary effects.

The calling condition will be extended stage by stage over the forward transmission path during the process of setting up a call but a space will be maintained in the backward transmission path (except for the return of a short pulse of mark as the Proceed to Dial signal), until the call is connected, when a mark will be returned.

Clearing conditions may be initiated from either end of a connexion although the holding (supervisory) circuits at each switching centre will be connected to the forward transmission path only. Polarised relays will be employed to determine this clearing condition (*i.e.*, space maintained for a minimum period of 300 mS).

Connexions through the switching equipment will be established on a 3 wire basis; send (S), receive (R) and private (P). The P wire will, however, be split at each selector to facilitate the provision of battery testing facilities, with backward holding.

### 9.2 Line supervisory signals (local call).

The line signalling conditions can most readily be followed by tracing the progress of a local call from one station to another. Such a connexion is illustrated in Fig. 17.

*Station "A" calling.* Depression of the "Dial" key causes relay D to apply negative battery to the S wire and operate relay L in the station line circuit.

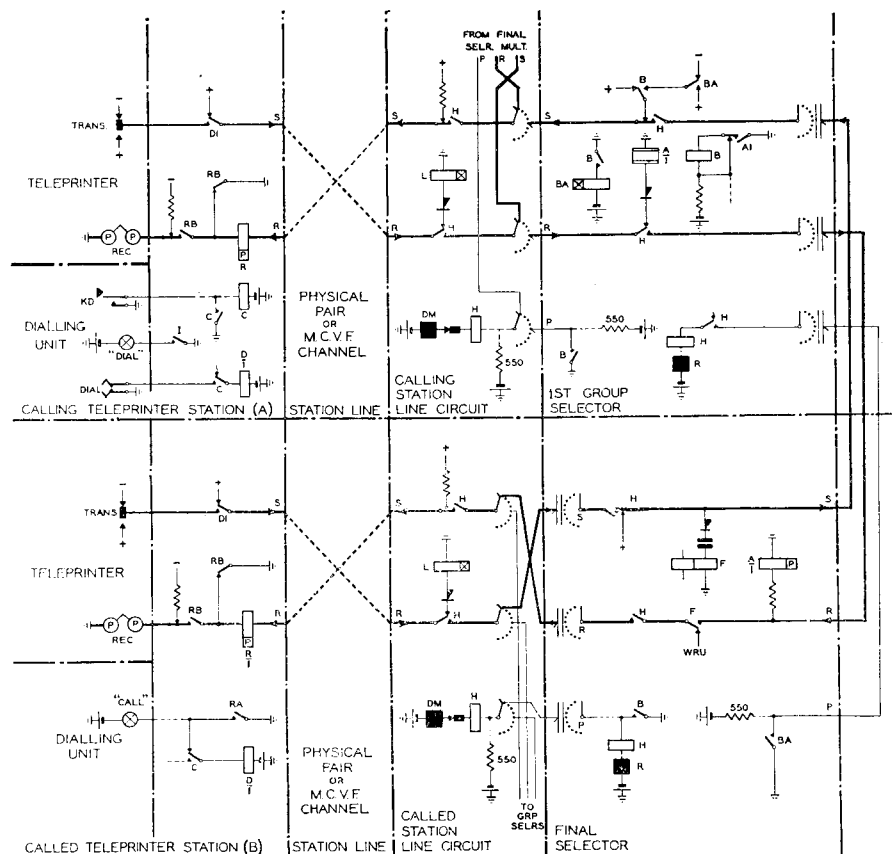

FIG. 17.—LINE CONNEXIONS (SCHEMATIC) LOCAL CALL.

The unselector searches for a free group selector, positive battery being maintained on the S wire at the switching centre.

*Proceed to dial signal.* On seizure of a free group selector, relay A operates to negative battery and prepares the selector for impulsing. The successive operation of relays B and BA applies to the S wire a short pulse of negative battery which is received on the R wire at the station and operates relays which illuminate a "proceed to dial" lamp.

*Dialling.* The impulses from the dial are relayed to line as double current signals by relay D. The group selector A relay responds to these signals and the selector accepts the first digit in the usual manner and hunts for a free final selector.

When seized by negative battery extended by the group selector, the final selector accepts the tens and units digits and tests for a free line to the called station. Positive battery is maintained on the S wire at the final selector.

*Connexion to station B.* When the final selector seizes a free line, the H relays in the selector and the called station line circuit (SLC) operate together and negative battery is extended on the R wire to seize the equipment at station B. Operation of relays at station B connects the teleprinter to the S and R wires and negative battery is returned on the S wire, to operate relay R and relief switching relays at station A.

Both teleprinters are now connected to the line and "Who are You" (WRU) signals are sent, from the common signal generator, via the final selector to operate the teleprinter at station B and cause it to return the answer-back signal to the calling station.

The answer back signal also operates relay F in the final selector which disconnects WRU signals from the line and completes the connexion.

Negative battery is now connected to both line conductors.

While the call is in progress, the only line relays remaining in circuit are the R relays at the two teleprinter stations and the A relay in the final selector. These are telegraph relays and respond to all signals in the line, controlling relief relays which are arranged so that they hold the connexion during the passage of teleprinter signals.

*Calling party clears (Station A).* Clearing is normally controlled by the originating operator and is effected by the release of relay D which connects positive battery to the S wire. Relay A at the final selector and relay R at station B release and permit also the release of the respective holding relays. The relays at station B disconnect the teleprinter from the line and the final selector removes earth from the P wire thus releasing the equipment within the switching centre.

The first item of equipment to release returns positive battery to release relay R at station A and completes the release of the connexion. Positive battery is now connected to both lines.

*Called party clears (station B).* A clearing signal from the called station commences with the release of relay D at that station and the return of positive battery to release the equipment at the calling station.

The consequent release of relay D at the calling station extends positive battery on the S wire and causes the release of the final selector A relay and relay R at station B as previously described. The switching equipment and station B apparatus then release.

### 9.3 Line supervisory signals (trunk calls).

The arrangement of the equipment used in a trunk connexion is illustrated in Fig. 18.

On seizure of a trunk circuit, negative battery is extended to engage the circuit against calls offered in the opposite direction of traffic and prepares the i/c trunk selector for impulsing. At the same time the trunk relay set (TRS) at the O/G end returns earth on the P wire under control of its A relay and holds the preceding switching apparatus.

When the call has been dialled to completion, negative battery is returned from the called station, via the trunk circuit, to complete the connexion at the calling station and the call then proceeds as for a local call. The A relay in the trunk relay set at the outgoing end monitors the line signals and in conjunction with its relief relays holds the apparatus at the originating switching centre. The apparatus at the called switching centre is held under the control of the final selector A relay.

## 10. CIRCUIT FEATURES.

### 10.1 Teleprinter station circuit.

Long standing requirements of the inland service are that circuits shall be capable of simultaneous working in both directions of transmission without a local copy of transmitted matter. These features together have favoured the continued use of two wire simplex station lines using double current signalling and, together with the facilities mentioned in para. 6, entail the provision of relay equipment at the teleprinter station to perform the necessary discriminating functions. The basic circuit arrangements at a teleprinter station are shown in Fig. 19.

*Originated calls.* Operation of the "dial" key (KD) operates relay C which holds via its own contact and operates relay D. Contact D1 connects negative battery to the S wire to operate the line equipment at the switching centre. On connexion being obtained to a free group selector, a short pulse of negative battery is received on the R wire and relay R, responding to this pulse, operates relay I and causes the "dial" lamp to glow. Relay RA is slow to operate under control of resistor YA and condenser QA and does not operate at this stage. Relay I also operates the teleprinter motor start relay.

During the ensuing dialling, relay D responds to the break and make impulses of the dial contacts and repeats them to line as double current signals. On completion of the connexion, relay R operates to negative battery on the R wire and relay RA operates slowly. Relay RA illuminates the "call" lamp and operates a relief relay RB which connects the teleprinter receiver to the line. Relay RB re-arranges the control circuit of relay RA, thus enabling it to remain operated while relay R responds to teleprinter signals.

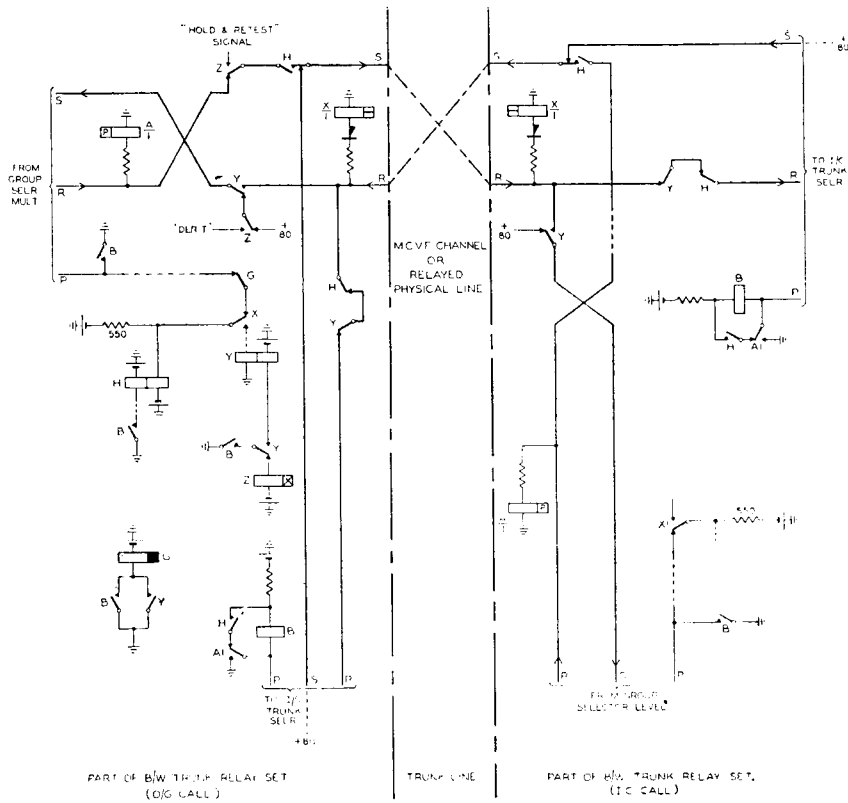

FIG. 18. SCHEMATIC, TRUNK CONNEXION.

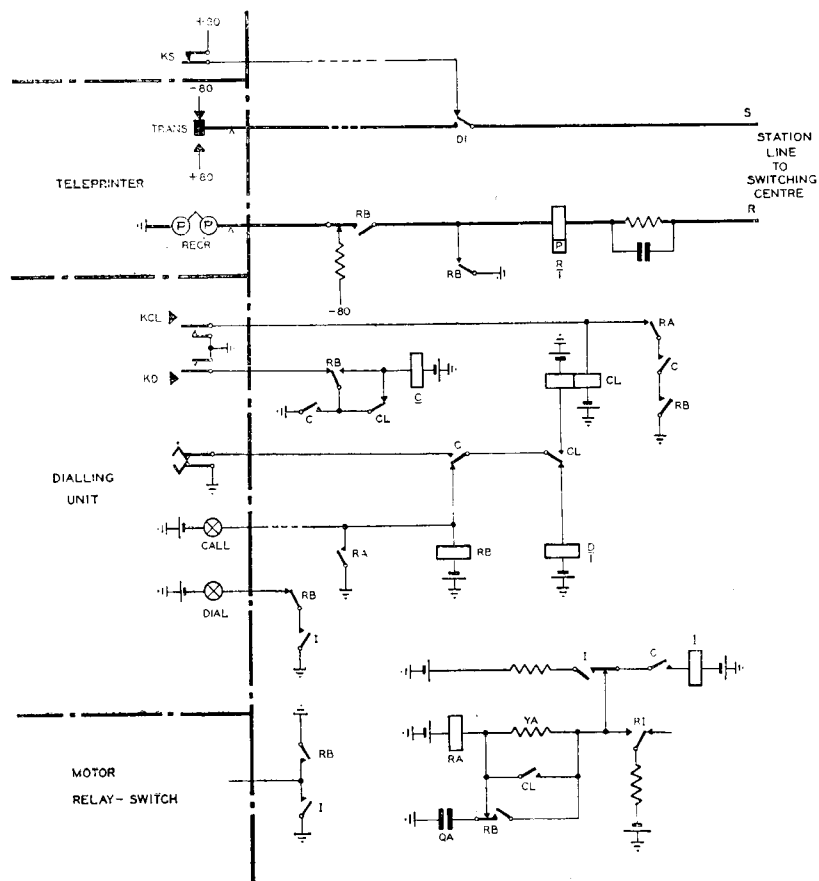

FIG. 19.—BASIC CIRCUIT FOR TELEPRINTER STATION.

The connexion is required to be held under all conditions of teleprinter code signalling and the most onerous condition is the repetition of the "all spacing" combination which in 7½ unit code comprises 120 mS positive and 30 mS negative battery intervals repeated continuously. The RA relay will, in fact, hold the connexion with this signal distorted by 50% so that the negative battery interval is reduced to 15 mS.

The connexion is released by operating the "clear" key (KCL) which causes relay CL to operate and hold under control of relay C. Relay CL releases relay D which applies positive battery to the S wire to release the automatic switching equipment. Positive battery is then returned on the R wire to release relays R, RA, RB, C, I and CL in the order stated and the circuit returns to normal.

The circuit may also be released by a positive battery condition on the R wire which can be initiated by the called party or by a false clearing condition occasioned, for instance, by a line fault. In this case relays R and RA release causing relay CL to operate and RB to release. Relay CL operating releases relays C and D after which relay CL also releases. Relay D connects positive battery to the S wire to release the automatic equipment.

The teleprinter motor stops when the circuit is released.

*Received calls.* When the circuit is seized by an incoming call negative battery is received on the R wire when relays R, RA, RB and D operate causing the teleprinter motor to start and connecting the teleprinter to the line. The "call" lamp also glows to indicate the arrival of a call.

The connexion is normally released by the originating office in which case positive battery on the R wire causes relay R to release followed by relays RA, RB and D so that the circuit restores to normal.

The connexion can also be released by an operator at the called station. Operation of the clear key (KCL) causes relay CL to operate and hold under control of relay RA. Relay D releases and connects positive battery to the S wire to release the relays at the calling station. This in turn results in a positive battery being received on the R wire to release all relays at the called station and to release the automatic equipment at the switching centre.

*Purpose of E.P.R.* The "either party release" feature facilitates the provision of certain safeguards, notably in preventing a sending operator from continuing to transmit to a circuit which has become faulty. Disconnexions in physical lines or "spacing" faults on VF channels, wherever they may occur in a connexion, result in its complete release. The sending operator is made aware of this by the dimming of the call lamp and the teleprinter motor stopping. Similarly it is arranged that a paper fault on either teleprinter causes the CL relay to operate and so releases the connexion. In this event the circuit is also engaged to incoming traffic until the fault has been cleared.

*Out of service facility.* A key (KS) is provided to enable the circuit to be closed to traffic or placed "out of service" when required. With physical lines the S wire is disconnected but at stations served by

VF channels a strap is inserted in the position unit so that operation of the OOS key connects negative battery to the S wire.

The way in which these signals operate is described later in relation to the equipment at the switching centre.

## 10.2 The Station line circuit (Fig. 20).

In addition to the usual functions of connecting incoming and outgoing calls to the station line and of providing unselector access to the first selector stage, the station line circuit has to guard the final selector multiple appearance after the release of a connexion to allow for the release of the supervisory relays at the teleprinter station. The circuit also provides for the station line being closed to traffic under control of the "out of service" key at the teleprinter station.

Relay L operates to the calling signal (negative battery) on the station line and causes the unselector to drive. Relay T operates to 550 ohm battery on the P wire of a free group selector and cuts the drive circuit. Relay H switches the lines through to the group selector which, when seized, returns earth on the P wire to hold relay H. Relay G operates and relay L releases slowly.

Relays H and G remain operated for the duration of the call. On release of the connexion, earth removed from the P wire releases relay H which completes a homing circuit for the unselector. Relay G releases slowly after the home contact is reached and maintains sufficient guard on the P wire of the final selector multiple to allow for the release of the station equipment.

For a call to the teleprinter station relay H is operated via the final selector multiple P wire and operates while the selector is switching. This reduces the unguard on seizure of the B.W line to a minimum. Relay G operates after relay H and both relays remain operated for the duration of the call.

Relay G guards the circuit on release of the connexion.

*Out of service condition.* On physical lines, disconnexion of the S line allows relay L to operate via its local circuit. The unselector hunts and switches to a free group selector and relays H and G operate. Owing to the disconnexion on the line, the group selector A relay does not operate and earth is not returned on the P wire to hold relay H in the S.L.C. Release of relay H causes the re-operation of relay L which provides a holding circuit for relay G via contact L4. Relays L and G remain held and the unselector drives to the home contact. Relay G engages the P wire of the final selector multiple.

On station lines which include a V.F. telegraph channel negative battery on the S line causes the unselector to find a free group selector which is held without dialling ensuing. The group selector is forcibly released under control of a time pulse within 12—24 seconds of seizure and releases the S.L.C. Negative battery on the line, causes relay L to re-operate and hold relay G so that the circuit goes out of service as previously described.

*Suspense control.* Contacts of relays L and G pass information of the state of the circuit to a suspense relay set and function as described in para. 10.5.

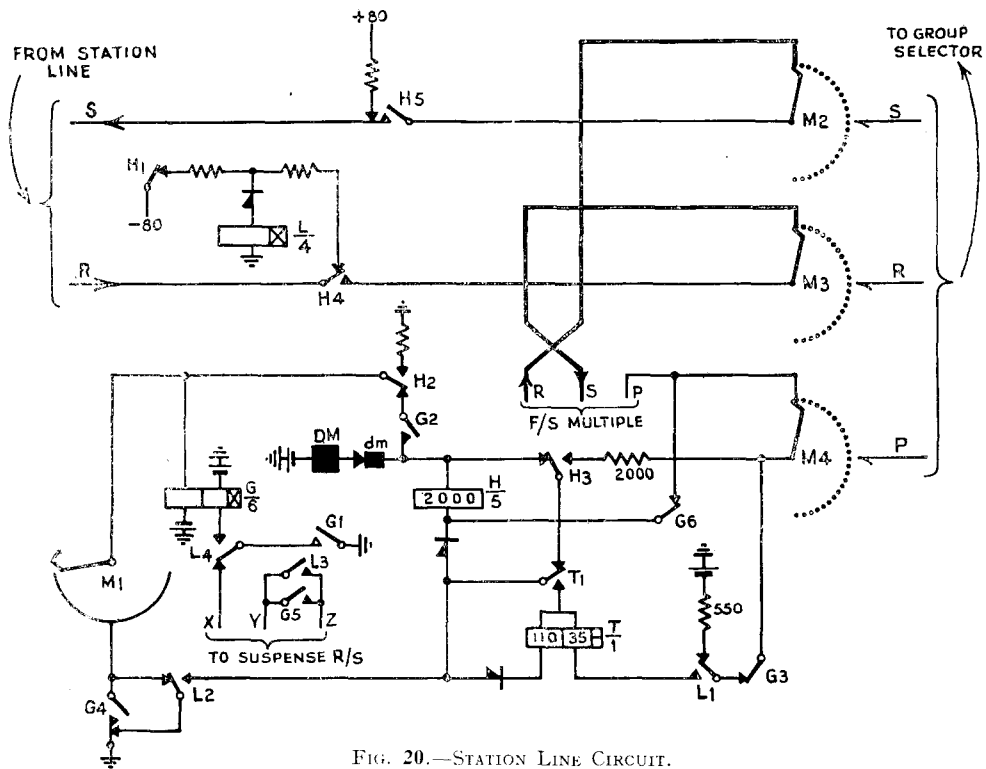

FIG. 20.—STATION LINE CIRCUIT.

### 10.3 The group selector.

A single type of 200 outlet group selector is used throughout the network, provision being made in the wiring of the shelf jacks for the exclusion of certain facilities where these are not required.

The A relay is a standard 3000 type selector impulsing relay and is adapted to receive double current impulses by the use of metal rectifiers which are arranged so that the relay operates only to negative battery. The circuit arrangement is shown in Fig. 21a condenser QB being included to assist the decay of flux in the relay at the commencement of each positive battery or "break" element in the impulse train.

The B relay and the vertical stepping and rotary cut-in circuit are of conventional design but the P wire testing and switching arrangements are unusual in that a battery testing system using high speed relays has been adopted to ensure the greatest possible security against double connexions. The circuit used is shown in Fig. 21b. After cutting-in, the wipers rotate under rotary self-drive action until either relay AH or BH operates to 550 ohm battery on the P wire of a free outlet. The HA or HB relay coil is then connected in series with the rotary magnet which does not re-operate so that the wipers remain on the free outlet and the switching relay operates. If both outlets are free relay AH operating prevents the operation of relay BH and the selector switches to the A choice.

Operation of the switching relay causes the high speed relay to release and extends the lines to the forward apparatus which then returns earth on the P wire in place of 550 ohm battery. On release of the

selector A and B relays consequent upon operation of the switching relay, the latter is held by the earth returned on the P wire.

*Proceed to dial signal.* Ordinary first selectors are required to return a 20–40 mS pulse of negative battery on the S wire, when seized, to indicate to the caller that dialling may proceed. This pulse is generated in the selector by the successive operation of relay B and its relief relay BA which is slow operating (Fig. 17). The same pulse is also used on trunk selectors to provide a check of the continuity of the

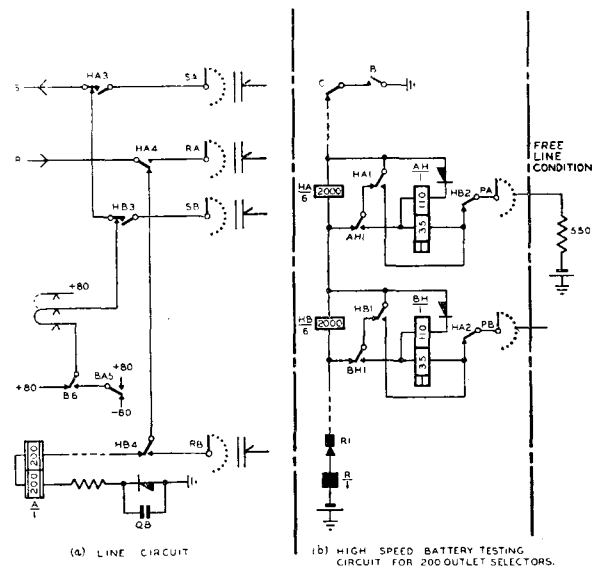

FIG. 21.—GROUP SELECTOR ELEMENTS.



trunk circuit, but on other ranks of selectors the pulse generating contacts are disconnected and replaced by positive battery by strapping on the shelf jacks.

**Forced release.** Relay BA also prepares a forced release circuit which, in conjunction with 12 second S and Z pulses prevents first selectors from being held continuously due to misoperation of the position equipment. The facility also assists in the application of out-of-service conditions to station lines routed on V.F. channels.

#### 10.4 The final selector.

The final selector provides access, with group hunting, to circuits on 10 levels each of 20 circuits.

The apparatus used in a connexion within the switching centre is held under control of the final selector and for this purpose the selector A relay is connected permanently to the R wire so that it monitors the signals transmitted from the calling station (Fig. 22). A sensitive polarised telegraph relay is used for this duty and ensures the accurate

repetition of the signals to the B relay over lengthy periods of service and without incurring material attenuation of the line signal. The B relay, in addition to performing the normal functions of a selector B relay also remains operated during the passage of teleprinter signals.

An additional spark quench has been provided to protect the A relay contacts from the surges occurring in the B relay circuit during the passage of teleprinter signals. Life tests of this circuit under artificial call conditions have shown that a service life of approximately six months can be expected on first choice selectors without attention to the A relay.

The vertical and rotary stepping arrangements of the selector are orthodox and the release of relay E at the completion of rotary stepping provides a self drive circuit so that the wipers hunt over the ensuing group of contacts. High speed battery testing relays are connected to the PA and PB wipers as in the group selectors and further high speed relays simultaneously test the TA and TB banks which are provided for

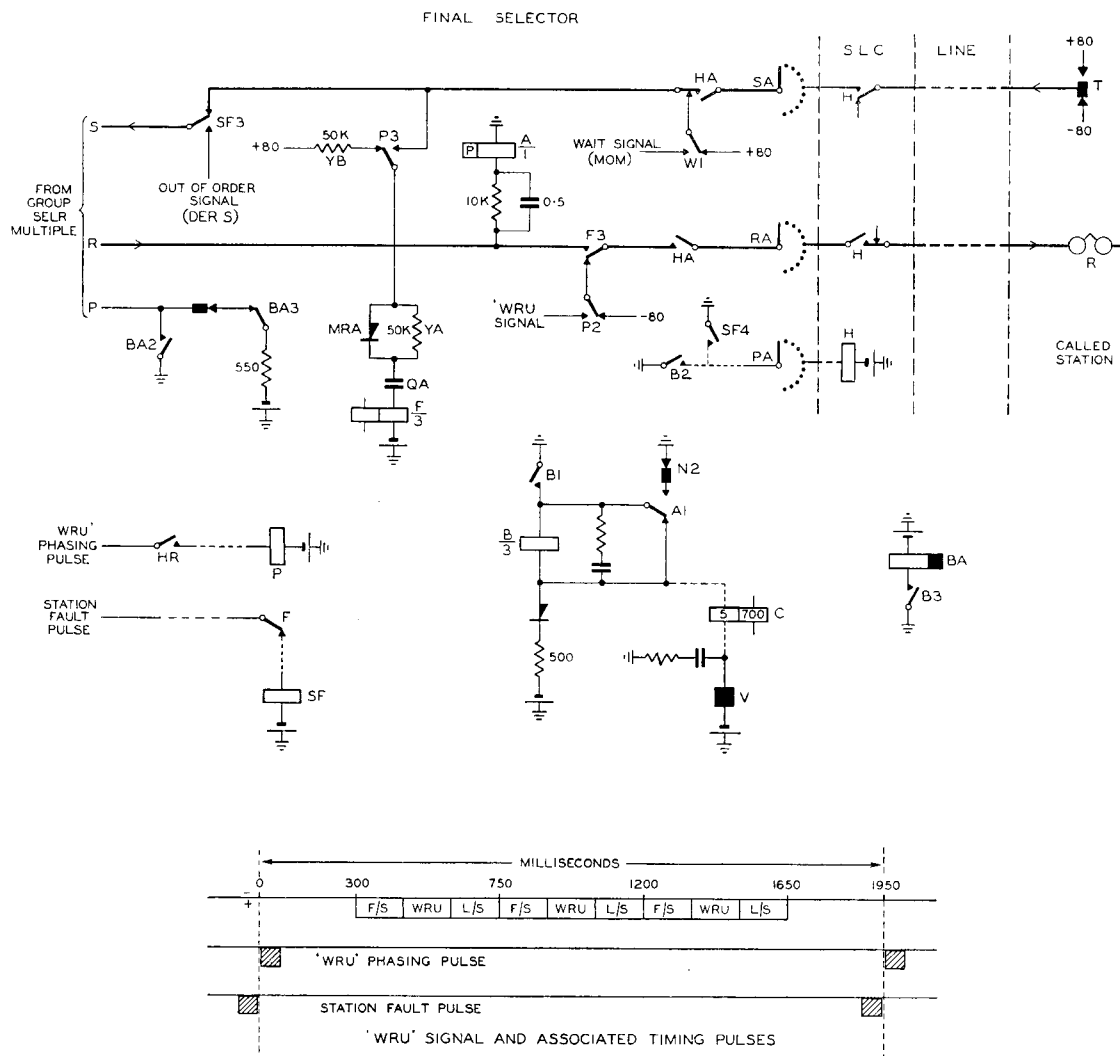

FIG. 22.—FINAL SELECTOR LINE, IMPULSING AND CALLING ELEMENTS.

suspense and group control purposes. The circuit arrangement is shown in Fig. 23.

*Call to a free line.* A call finding a free line within the group is connected normally, after operation of relay AHA or AHB, by the operation of the corresponding switching relay HA or HB.

*Return of answer back signal.* Before completing the connexion, the final selector connects a source of WRU signals to the called line to obtain the return of the answer back signal. The signal sequence which is adopted to meet this requirement is illustrated, together with its associated time pulses, in Fig. 22.

When the final selector switches to a free line, negative battery is extended via the RA wiper. A circuit is also prepared for relay P to operate to the WRU phasing pulse preceding the next complete WRU signal sequence. Relay P operating connects relay F to the S wire and connects the WRU signal feed to the R wire. The WRU signal cycle is preceded by a 300 millisecond interval of negative battery to ensure the correct seizure of the called station apparatus and to allow the teleprinter motor to start and attain working speed. The consequent return of negative battery on the R wire indicates the call matured condition at the calling station and completes the operation of the circuit there. It also causes the charge on condenser QA slowly to reverse its sign via the resistor YA in preparation for relay F to operate.

The called teleprinter accelerates in time to receive correctly one of the three repetitions of the WRU signal whereupon it returns the answer back code.

The first positive battery element of this signal rapidly reverses the charge in condenser QA via the forward resistance of rectifier MRA and the current surge operates relay F which disconnects the WRU signals and completes the connexion.

*Faulty station lines* (Fig. 22). The foregoing sequence of events also provides a check of the continuity and operation of the station line and its associated equipment. Failure to receive an answer back signal would be indicative of a faulty line or teleprinter and is evidenced by failure of relay F to operate. In such a case relay SF operates to the "station fault" pulse at the end of the WRU signal sequence and holds the Final Selector and the station line circuit via the P wire. An out-of-order signal (DER S) is returned on the S wire to inform the caller that a faulty line has been encountered.

When the caller sends the clearing signal the final selector releases the preceding switches but remains held in connexion with the faulty line. So long as the selector remains off normal it cannot be seized by following calls and subsequent attempts to call the same office result in connexion to another line. Attention is drawn to the fault condition by a local alarm in the switching centre.

*Delayed hunting (suspense) condition* (Fig. 23). When all of the lines to an office are engaged, 550 ohm battery is applied to the TA bank of a waiting contact at the beginning of the group. Relay AW operates and prevents further rotary motion when the wipers alight on this contact. Relay W operates in series with

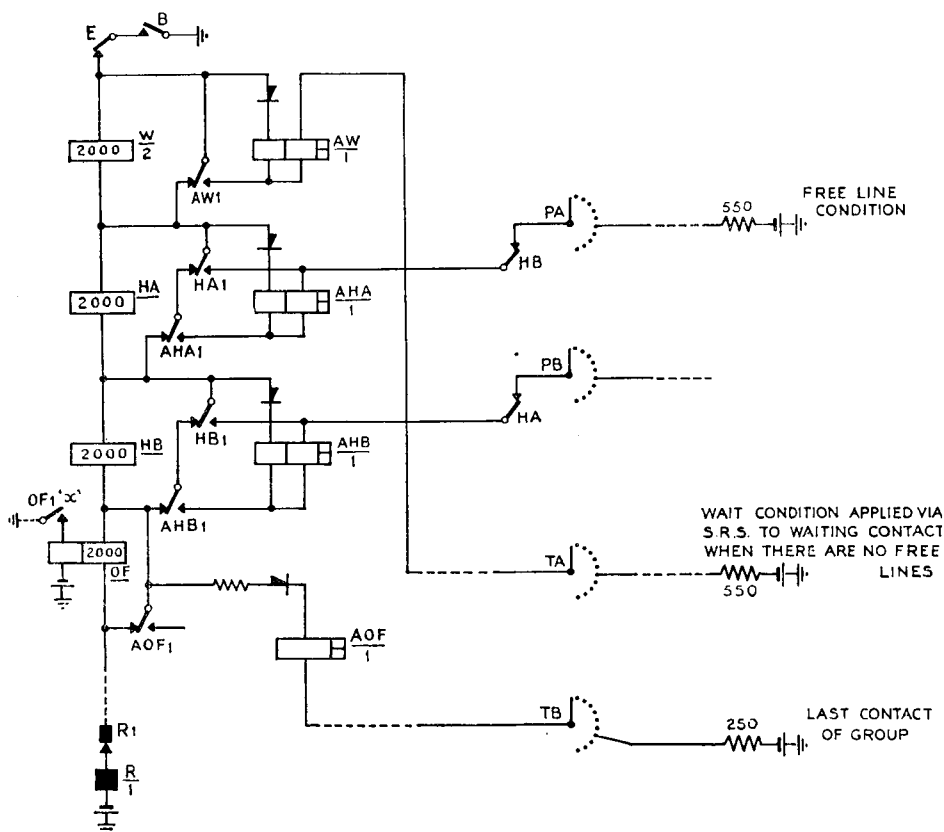

FIG. 23.—FINAL SELECTOR, MULTIPLE TESTING RELAYS.

the rotary magnet and connects a "wait" signal (MOM) on the S wire to advise the caller to wait for subsequent connexion. Relay AW applies a low resistance earth to the wait contact TA bank to prevent another selector from waiting on the same contact.

When a line becomes free, battery is removed from the wait contact allowing relay AW to release. This completes the normal testing circuit for relays AHA and AHB and simultaneously completes the rotary self-drive circuit. The selector searches for the free line and completes the connexion in the normal manner.

Owing to the use of high speed drive cutting relays it is possible to associate working lines with the waiting contact. If a line associated with a waiting contact becomes free, relay AHA or AHB operates within 1 mS of the release of relay AW thus preventing the wipers from stepping and enabling the selector to switch to the free line.

*Overflow condition* (Fig. 23.) The duration of the waiting period is limited to 30—60 seconds after which battery is removed from the TA bank of the waiting contact and relay AW releases. The wipers then hunt to the last contact of the group where relay AOF operates to 250 ohm battery on the TB bank. Relay OF operates and causes the wipers to drive out of the level, the circuit of the testing relays being cut to prevent seizure of lines in other groups on the level. The wiper carriage then restores to normal and relay OF releases. A vertical stepping circuit has meantime been prepared so that the wiper

carriage rises under self-drive until arrested by the operation of normal post springs at the overflow level. The NP springs also cause relay C to release after which the wipers cut in and test for a free outlet. The selector switches to the outlet and completes the connexion in the normal manner.

### 10.5 The suspense relay set.

The station line circuits of a group of lines serving a teleprinter office have associated with them a suspense relay set which controls the application of waiting conditions to calls offered to the group.

Calls are required to wait when :—

- (a) all lines in the group are engaged.
- (b) some lines are out of service and the remainder are engaged.

In either case there is a prospect of an engaged line becoming free to which the waiting call may be connected.

Calls are not required to wait when :—

- (c) there is one or more free lines available.
- (d) all lines are out of service.

In the last case there is no immediate prospect of a line becoming available.

The necessary discrimination between these conditions is obtained from additional contacts on the L and G relays of the station line circuits. These contacts are associated with the suspense relay set as shown in Fig. 24.

When all lines are engaged the G relays are operated and the L relays are released. Earth is thus applied to the series chain of G relay contacts to operate

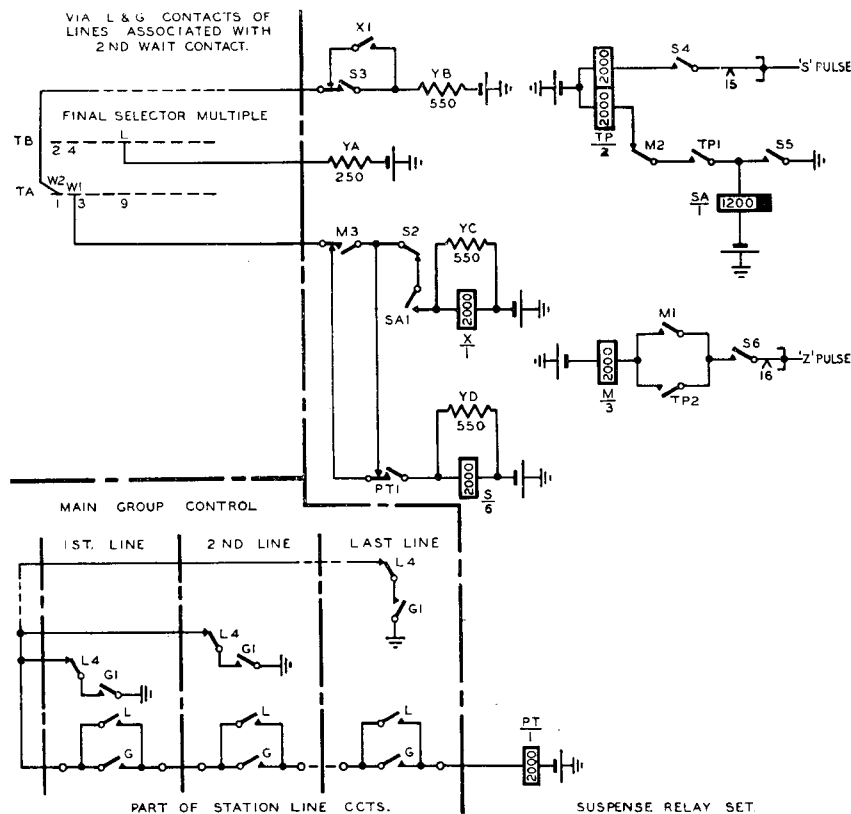

FIG. 24.—SUSPENSE CONTROL ARRANGEMENTS

relay PT in the S.R.S. Relay PT operated delays the hunting of final selectors offering calls to the group.

*When all lines are Out of Service* the L and G relays are all operated. Earth is disconnected from the series chain at contacts L4 and relay PT does not operate. Calls offered to the group are thus overflowed without delay.

*When some lines are OOS and the remainder are engaged* earth is present at the L4 contacts of the engaged line or lines and, the series chain also being complete, relay PT operates and causes selectors to wait.

The suspense relay set provides for a maximum of two waiting contacts, the waiting calls being released in chronological sequence.

*Group with one waiting contact.* Where one waiting contact is provided its position in the multiple corresponds with the directory number of the office and calls offered to the office alight on the waiting contact.

When waiting conditions exist, relay PT is operated and 550 ohm battery is applied to the TA bank of the waiting contact. On the arrival of a further call the final selector is held on this contact as already described and relay S in the suspense relay set operates and prepares the time pulse relays TP and M. Normally, waiting conditions are terminated by a line becoming free when relay PT releases and removes battery from the TA bank thus allowing the selector to hunt. If engaged conditions persist, however, relays TP and M operate on successive S and Z pulses. Relay M disconnects the TA bank of the waiting contact and releases the selector which hunts over the group. The 250 ohm battery on the TB bank of the last contact of the group is also fed from the suspense relay set and causes the selector to re-route the call to the overflow level.

*Group with two waiting contacts.* To provide correct chronological release of calls it is arranged that the second waiting contact corresponds to the directory number of the office so that all calls alight first on this contact but are only held there if all lines and the first waiting contact are engaged. The circuit operation, so far as the first waiting contact is concerned, is the same as has already been described.

When all lines are engaged and a selector is held on the first waiting contact relay S operating applies 550 ohm battery to the TA bank of the second waiting contact. The next call offered to the group is held on this contact and there are then two waiting selectors. Relay SA is also operated by relay S.

A line becoming free in the main group of lines causes relay PT to release and disconnect the TA wire of the first waiting contact. The first waiting selector hunts for the free line and relay S releases and disconnects the TA wire of the second waiting contact. At the same time 550 ohm battery is applied via YC to the first waiting contact so that the second waiting selector steps forward and is held on the first waiting contact. Relay X operates and re-applies battery to the second waiting contact to hold any following call.

Relay PT re-operates when the first waiting selector seizes the free line and relay S re-operates. Relay X releases and the conditions are, as previously, all lines engaged and a selector held on the first waiting contact.

Release of the first waiting selector due to the time pulse results in a similar movement forward of the second waiting selector to the first waiting contact and waiting calls are, thus, offered in correct order to the main group of circuits.

If two selectors are waiting and a line associated with the second waiting contact becomes free, the suspense condition is removed from the second waiting contact and the second waiting selector switches to the free line.

### 10.6 Outgoing selector level relay set.

This relay set provides for access to station lines from group selector levels and is arranged to hold the connexion and to secure the automatic return of the answer back signal from the teleprinter station. The circuit elements are similar to those already described for the final selector and include the return of an out-of-order signal on faulty lines.

### 10.7 The trunk relay set.

B/W trunk circuits terminate at each switching centre in a trunk relay set with which is associated a group selector. When the circuit is idle the group selectors are connected directly to the trunk line. The arrangement of the apparatus is illustrated in Fig. 18, and it will be seen that positive battery is connected to the S wire at each end of the circuit so that the V.F. channel is in the tone-off condition and the group selector A relays are not operated.

*Normal seizure.* On seizure of a free trunk via the o/g group selector level, relay H connects the calling circuit to the trunk line with the minimum of delay. A high speed relay X connected to the R wire at the i/c end of the trunk operates to the resulting negative battery condition and disconnects the P wire of the local group selector multiple. By the arrangement adopted, the unguard on seizure of the bothway circuit is reduced to a minimum.

While the i/c end of the trunk is being engaged, relays A and B operate at the o/g end and apply earth to the P wire to hold the preceding switches. A circuit is also completed which causes relay Z to commence operating slowly. At the i/c end the group selector is seized and returns a short pulse of negative battery over the trunk circuit to operate relays X and Y at the o/g end. Operation of relay Y disconnects relay Z, and completes the connexion of the R wire at the o/g end. The S wire having already been connected, however, dialling may continue without reference to the time at which relay Y operates and no abnormal inter-digital pause is necessary.

*Faulty trunk line.* With a faulty trunk circuit the test pulse will not be received and relays X and Y at the o/g TRS will fail to operate so that relay Z is allowed to complete its operation.

Relay Z disconnects the called station from the trunk line and connects an out of order signal (DER-T) to inform the calling operator that a faulty

trunk line has been encountered. On release of the connexion by the caller, the faulty circuit remains engaged to following traffic and a "hold and retest" signal is applied to the S wire of the trunk. This signal is applied at 30 second intervals so that, in the event of the fault becoming clear within a testing period, the group-selector at the i/c end returns a negative battery pulse to operate relays X and Y. Relay Z then releases and the circuit restores to normal. Transient faults are not uncommon on V.F. telegraph circuits due to irregularities in the system line and temporary failures of trunk circuits may be expected. A satisfactory retest is then likely to be obtained within a short period. Failure to obtain a satisfactory retest after five half minute intervals causes the o/g TRS to disconnect the "hold and retest" signal and operate an alarm at the switching centre.

The automatic testing of trunk circuits on seizure, in the manner described, and the automatic busying of faulty circuits is designed to prevent an excessive lowering of the grade of service on a route such as might otherwise occur due to a single faulty early choice circuit. It has the incidental advantage that, with the automatic hold and retest facility, the effects of transient faults are minimised. These features are not intended in any way as an alternative to the maintenance of a high standard of continuity in the V.F. telegraph systems themselves without which a satisfactory grade of service cannot be given.

*Guarding.* On release of a connexion it is necessary to prevent re-seizure of the circuit until the apparatus at both ends of the trunk line has had time to restore to normal. Slow releasing relays maintain a disconnexion on the P wire for a period sufficient to cover any difference in release times of the clearing supervisory relays at the two ends of the circuit plus the release time of the group selector at the incoming end. Backward release guarding is effected by relays X and Y which restrain the release of the guard relays until positive battery is returned from the calling station.

## 11. SPECIAL SERVICES.

A number of special services are required at each switching centre principally for engineering purposes, to which access is obtained from group selector levels. The number of circuits in each group is generally too small to justify the allocation of a group selector level and the delayed hunting and overflow facilities of the ordinary final selector render it unsuitable for this traffic. A special services final selector has been provided to enable a number of groups to be accommodated on each level. Access relay sets are also required for each service circuit, primarily to ensure the phased connexion of the various signals to the calling station.

The services to be provided are :—

1. Access to a test message sender from which test messages with different degrees of distortion are obtained as a test of teleprinter receivers. Messages distorted by 0, 20, 25 and 30% are available.

2. Access to a speed test signal for use in conjunction with a stroboscopic speed tester for accurately checking the speed of teleprinter motors.
3. Access to speaker circuits to V.F. telegraph terminals.
4. Access to test desk lines.

### 11.1 The special services final selector.

The special services final selector is a 200 outlet selector giving access to 10 levels each of 20 outlets with group hunting facilities on each level. The A and B relays perform the same functions as those in the ordinary final selector and the associated equipment within the switching centre is held from the special services final selector. The circuit design closely follows that of the ordinary final selector but no provision has been made for delayed hunting, overflow calls or automatic return of answer-back signals.

The group hunting facility provides for the testing of all circuits within the group dialled and, if all circuits are engaged, for the wipers, after reaching the last contact of the group, to drive to the eleventh step where the selector switches and returns the engaged signal (OCC).

## 12. TESTING EQUIPMENT.

To assist in the efficient maintenance of the system testing equipment is being provided which is specially suited to the purpose. This equipment may be grouped under four main headings :—

### 12.1 The test desk.

In addition to full D.C. testing facilities provision is also being made for dial speed and ratio testing and accurate measurement of teleprinter signal distortion including a check of signal speed. Teleprinter communication will normally be used in transactions with the test desk. The test desk will be adjacent to the E.C.B.

### 12.2 Speaker and test sets.

Test sets used on automatically switched circuits will be of special design and are intended as an aid to localising the more simple types of fault and for monitoring duties. Test sets will also be provided at V.F. terminals serving the more distant teleprinter stations and will be equipped for dealing with faults on the physical extensions of the station lines. Speaker facilities are also provided.

### 12.3 Portable testers.

Portable testers are being provided for use at teleprinter stations to provide a direct check of the performance of the teleprinter and associated relay equipment.

### 12.4 Routine testers.

Portable routine testers are being provided for use on the automatic switching apparatus. The testers will be automatic in action although access to the

relay set or selector under test will be obtained manually. A typical tester is shown in Fig. 25.

An automatic tester has also been developed for use at suitable centres at which routine overhauls of position relay sets will be conducted. The relay set is jacked into the tester which provides for a thorough test such as could not be undertaken with the item in situ.

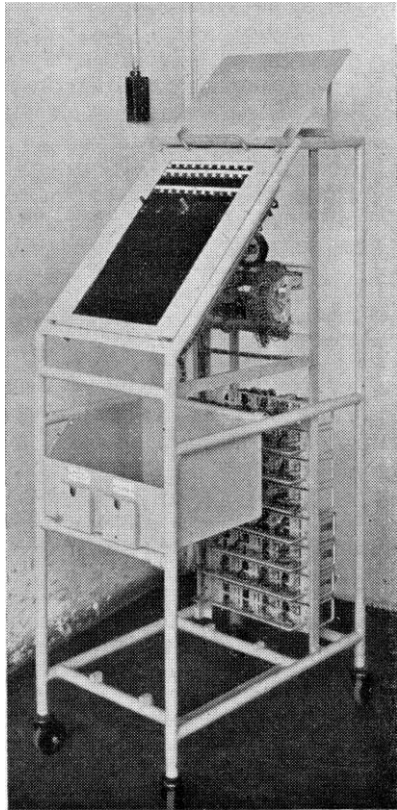

FIG. 25.—TESTER FOR TRUNK RELAY SET.

### 13. OBSERVATION EQUIPMENT.

Facilities will be provided at all switching centres to enable service observation to be made on either station line or trunk circuits. Circuits under observation will be connected from their relative "monitor"

jacks at the E.C.B. to individual tapping relay sets, and thence via a common junction relay set to the observation equipment. All signals passing over each leg of a circuit under observation, will be displayed, either by lamps (*e.g.*, dialling display), or on the teleprinters associated with the observation position. Facilities for enabling continuous observation to be made on a selected circuit are also provided.

### 14. CONCLUSIONS.

The introduction of an automatically switched system for the inland telegraph service is undoubtedly an important advance in the modernisation of this branch of telecommunications, which should enable a much improved service to be provided at less overall cost. The aim of the present paper has been to provide a general survey of the principal features of the scheme, both in application and design, but by reason of the wide scope of the subject matter much detail information has, of necessity, been omitted.

The paper would not be complete without acknowledgment being given to all those who have contributed towards the development of the scheme, including Messrs. The General Electric Co. Ltd., who were nominated by the B.T.T.D.C., to undertake the equipment development and who are installing the initial switching centres at London and Birmingham. The authors also wish to acknowledge with thanks the assistance given by colleagues of the Telegraph Branch, Engineer-in-Chief's Office, during the preparation of the paper.

#### References :—

- (1) L. H. Harris, "Automatic Teleprinter Switching," P.O.E.E. Journal, 1936, Volume 29, pp. 217.
- (2) H. E. Wilcockson & C. W. A. Mitchell, "Introduction of Manual Switching of Teleprinter Circuits in the Public Telegraph Service," P.O.E.E. Journal, 1947, Volume 40, pp. 69.

# THE INSTITUTION OF POST OFFICE ELECTRICAL ENGINEERS.

## PRINTED PAPERS.

The following papers contributed to the proceedings of the Institution have been printed by authority of the Council and may be obtained, if still in print, from

" THE LIBRARIAN,  
The Institution of Post Office Electrical Engineers,  
G.P.O. (ALDER HOUSE), LONDON, E.C.1."

The prices do *not* include postage, and in every case Members, Associate Members, and Associates have the privilege of purchasing copies at two-thirds the stated price.

O*+No. 115.	" WAYLEAVES AND RELATIVE DIFFICULTIES."—B. MILLER. 1926 ... ..	6d.	O†No. 131.	" CARRIER CURRENT TELEPHONY."—Capt. A. C. TIMMIS, B.Sc., A.M.I.E.E. 1930 ... ..	1s.
O+No. 116.	" THE DIRECTOR IN AUTOMATIC TELEPHONY."—C. W. BROWN, A.M.I.E.E. 1927 ... ..	9d.	O No. 132.	" THE HEATING AND VENTILATING OF POST OFFICES AND TELEPHONE EXCHANGES."—W. T. GEMMELL, B.Sc., A.M.I.E.E. 1930 ... ..	9d.
O†No. 117.	" THE SUBMARINE LINK IN INTERNATIONAL TELEPHONY."—C. ROBINSON, B.A., A.M.I.E.E. 1928 ... ..	1s.	O No. 133.	" RURAL AUTOMATIC EXCHANGES."—J. C. DALLOW. 1929... ..	9d.
O+No. 118.	" SPARKING AND ARCING AT RELAY CONTACTS AND THE USE OF SPARK QUENCH CIRCUITS."—A. H. JACQUEST, A.M.I.E.E., and L. H. HARRIS, M.Sc., A.C.G.I. 1927 ... ..	1s.	O†No. 134.	" SOUND AND HEARING."—Capt. N. F. CAVE-BROWNE-CAVE, B.Sc., M.I.E.E. 1930 ... ..	9d.
O No. 119.	" THE PROBLEM OF THE P.B.X. CONNECTED TO AN AUTOMATIC EXCHANGE."—C. W. BROWN, A.M.I.E.E., and R. J. HINES, B.Sc. 1928 ... ..	9d.	O No. 135.	" THE ELECTRICAL CONTROL OF TIME SERVICES IN THE BRITISH POST OFFICE."—A. O. GIBBON, M.I.E.E. 1931 ... ..	1s.
O†No. 120.	" SATELLITE EXCHANGES IN AUTOMATIC AREAS."—F. I. RAY, B.Sc., D.F.H., A.M.I.E.E. 1927 ... ..	1s.	O+No. 136.	" SOME DEVELOPMENTS IN TELEGRAPH TECHNIQUE AS APPLIED TO RADIO CIRCUITS."—H. FAULKNER, B.Sc., A.M.I.E.E., and G. T. EVANS. 1931 ... ..	1s.
O†No. 121.	" X-RAYS, AND THE STRUCTURE OF SOME ENGINEERING MATERIALS."—W. G. RADLEY, B.Sc. 1929 ... ..	9d.	O+No. 137.	" INTERFERENCE WITH WIRELESS RECEPTION ARISING FROM THE OPERATION OF ELECTRICAL PLANT."—Col. A. S. ANGWIN, D.S.O., M.C., T.D., B.Sc., M.I.E.E. 1932 ... ..	6d.
O No. 122.	" THE MEASUREMENT OF RELAY TIMES."—R. W. PALMER, A.M.I.E.E. 1929 ... ..	9d.	O+No. 138.	" TELEPHONE CABLE TESTING METHODS."—W. T. PALMER, B.Sc., Wh.Ex., A.M.I.E.E., and E. H. JOLLEY, A.M.I.E.E. 1931 ... ..	1/3
O No. 123.	" MODERN ELECTRICAL ILLUMINATION."—J. J. EDWARDS, B.Sc.(Eng.), A.C.G.I., D.I.C. 1928 ... ..	9d.	O*+No. 139.	" DISTRICT ACCOUNTING."—T. FEWSTER. 1931 ... ..	9d.
O+No. 124.	" THE MEASUREMENT OF SOUND AND ITS APPLICATION TO TELEPHONY."—A. J. ALDRIDGE, A.C.G.I., A.M.I.E.E. 1929 ... ..	9d.	O No. 140.	" SOME NON-METALLIC SUBSTANCES AND THEIR CHARACTERISTICS."—Capt. N. F. CAVE-BROWNE-CAVE, B.Sc., A.M.I.E.E. 1931 ... ..	9d.
O No. 125.	" THE DEVELOPMENT OF AUTOMATIC ROUTINERS IN THE BRITISH POST OFFICE."—A. SPEIGHT, A.M.I.E.E. 1929 ... ..	9d.	O No. 141.	" THE TELEPRINTER No. 7A (CREED TELEPRINTER)."—R. D. SALMON. 1932 ... ..	9d.
O†No. 126.	" TELEPHONE CABLE CIRCUIT INTERFERENCE."—A. MORRIS, A.R.C.Sc., M.I.E.E. 1929 ... ..	1s.	O No. 142.	" PRIVATE BRANCH EXCHANGE INSTALLATIONS."—R. T. A. DENNISON. 1932 ... ..	1/3
O No. 127.	" SECONDARY CELLS (LEAD-ACID TYPE)."—H. M. TURNER. 1928 ... ..	6d.	O†No. 143.	" ELECTRIC WAVE FILTERS."—G. J. S. LITTLE, B.Sc. 1931 ... ..	1/3
O†No. 128.	" CRITICAL METHODS OF INVESTIGATION AS APPLIED TO THE STUDY OF TELEPHONE AREAS AND PLANT LAYOUT."—J. N. HILL. 1930 ... ..	1/3	O No. 144.	" SOME NOTES ON THE DESIGN AND MANUFACTURE OF TELEPHONE CABLES."—F. H. BUCKLAND and R. H. FRANKLIN, B.Sc. 1932 ... ..	1s.
O No. 129.	" PICTURE TELEGRAPHY."—E. S. RITTER, D.F.H., M.I.E.E. 1929 ... ..	9d.	O†No. 145.	" ROOM NOISE AND REVERBERATION AS PROBLEMS IN TELEPHONY."—W. WEST, B.A., A.M.I.E.E. 1932 ... ..	9d.
O+No. 130.	" COMPOSITED TELEGRAPH AND TELEPHONE WORKING."—J. M. OWEN, A.M.I.E.E., and J. A. S. MARTIN. 1930 ... ..	1/3	O†No. 146.	" LAYING ARMoured CABLE BY MEANS OF A MOLE-DRAINER."—L. G. SEMPLE, B.Sc.(Eng.), and R. O. BOCOCK, B.Sc.(Eng.) 1932 ... ..	9d.
			O†No. 147.	" DESIGN AND CONSTRUCTION OF ELECTRIC WAVE FILTERS."—R. J. HALSEY, B.Sc. 1932 ... ..	1/3

\* For Officers of the Department only.

† The Council have awarded Institution Medals for these papers.

O Signifies out of print.

## PRINTED PAPERS (continued).

<p>O No. 148. "STORES SPECIFICATIONS AND ACCEPTANCE TESTING."—Capt. J. Legg, B.Sc., A.M.I.E.E. 1933 ... 9d.</p> <p>O No. 149. "RECENT DEVELOPMENTS IN UNDERGROUND CONSTRUCTION, LAYING AND LOADING ARMoured CABLES."—J. E. Z. Bryden, B.Sc.(Eng.), A.M.I.E.E., and T. HARGREAVES, A.M.I.E.E. 1933 ... 1s.</p> <p>O No. 150. "TELEPRINTERS."—E. S. Ritter M.I.E.E. 1933 ... 1s.</p> <p>O No. 151. "RECENT REPEATER STATION INSTALLATIONS."—Major F. E. A. Manning, M.C., B.Sc.(Eng.), M.I.E.E., A.M.I.Mech.E. 1933 ... 1s.</p> <p>O†No. 152. "SOME NOTES ON EXCHANGE EQUIPMENT FACTORY COSTING AND THE ECONOMICS OF PRODUCTION."—S. J. Husband, Assoc.I.E.E. 1933 ... 1/3</p> <p>O†No. 153. "MODERN DEVELOPMENTS IN TELEPHONE TRANSMISSION OVER LINES."—J. Stratton, A.C.G.F.C., and W. G. Luxton. 1933 ... 1/3</p> <p>O†No. 154. "THE TELEGRAPH POLE."—W. H. Brent, B.Sc., A.M.I.E.E. 1933 ... 1s.</p> <p>O†No. 155. "A FEW RECENT DEVELOPMENTS IN TELEPHONE TRANSMISSION APPARATUS."—L. E. Ryall, Ph.D. Eng. (Lond.), A.M.I.E.E. 1934 ... 1s.</p> <p>O†No. 156. "MODERN TENDENCIES IN THE SUPPLY OF POWER TO TELEPHONE EXCHANGES."—H. C. Jones, B.Sc. (Eng.). 1935 ... 9d.</p> <p>O†No. 157. "RECENT ADVANCES IN CARRIER TELEPHONY."—R. J. Halsey, B.Sc., A.C.G.I., D.I.C. 1935 ... 1/3</p> <p>O†No. 158. "ULTRA SHORT WAVE RADIO TELEPHONE CIRCUITS."—D. A. Thorn, B.Sc. (Eng.), A.M.I.E.E., and H. T. Mitchell, A.M.I.E.E. 1935 ... 1s.</p> <p>O†No. 159. "MODERN ELECTRIC PASSENGER LIFTS."—R. S. Phillips, A.M.I.E.E. 1935 ... 9d.</p> <p>O†No. 160. "SOME PRACTICAL ASPECTS OF TELEPHONE CONDUIT AND MANHOLE CONSTRUCTION."—C. F. Thomas and A. T. Soons. 1936 ... 1/3</p> <p>O†No. 161. "MODERN TELEPHONE REPEATER STATION POWER PLANT."—F. W. G. Dye. 1936 ... 6d.</p> <p>O†No. 162. "VOICE FREQUENCY SIGNALLING ON TRUNK CIRCUITS."—T. H. Flowers, B.Sc., A.M.I.E.E., and B. M. Hadfield, B.Sc., A.M.I.E.E. 1937 ... 1s.</p> <p>†No. 163. "AUTOMATIC EXCHANGE DESIGN."—H. E. Francis. 1936 ... 1/3</p> <p>O†No. 164. "THE LONDON-BIRMINGHAM COAXIAL CABLE SYSTEM."—A. H. Mumford, B.Sc. (Eng.), A.M.I.E.E. 1937 ... 1/3</p> <p>†No. 165. "PROPERTIES AND TESTING OF DIELECTRIC MATERIALS."—J. F. Doust and W. J. Sulston, M.Sc., A.Inst.P. 1936 ... 1s.</p> <p>†No. 166. "CHEMISTRY AND COMMUNICATIONS."—D. W. Glover, M.Sc., A.I.C. 1937 ... 6d.</p> <p>†No. 167. "TWELVE-CIRCUIT CARRIER TELEPHONE SYSTEMS."—G. J. S. Little, B.Sc., A.M.I.E.E. 1938 ... 6d.</p> <p>O†No. 168. "THE DEVELOPMENT OF MAGNETIC MATERIALS."—C. E. Morgan, A.M.I.E.E. 1938 ... 6d.</p> <p>†No. 169. "CROSSTALK."—H. C. S. Hayes, A.M.I.E.E., R. A. Seymour and P. R. Bray, M.Sc.(Eng.). Grad.I.E.E. 1938 ... 1/3</p> <p>O No. 170. "SUBSCRIBERS' CABLE DISTRIBUTION—RECENT DEVELOPMENTS."—L. MEEK, A.M.I.E.E. 1939 ... 6d.</p> <p>O+No. 171. "MULTI-CIRCUIT CARRIER TELEPHONY."—E. M. Richards, A.C.G.I., B.Sc. (Eng.), M.I.E.E., and F. J. D. Taylor, B.Sc. (Eng.). 1938 ... 1/6</p> <p>O No. 172. "CORROSION AND COMMUNICATIONS."—C. E. Richards, F.I.C. 1939 ... 6d.</p>	<p>No. 173. "AUDIO-FREQUENCY RIPPLE FROM D.C. POWER SUPPLIES IN COMMUNICATION ENGINEERING."—H. R. Harbottle, B.Sc., D.F.H., M.I.E.E., J. A. Sheppard, B.Sc., A.M.I.E.E., and D. L. Richards, B.Sc. 1939 ... 1s.</p> <p>No. 174. "METALLURGY AND COMMUNICATIONS."—E. V. Walker, B.Sc., A.R.S.M. 1940 ... 6d.</p> <p>No. 175. "TELEPHONE EXCHANGE POWER PLANT DEVELOPMENT TRENDS AND WAR-TIME PROBLEMS."—W. J. Marshall. 1941 ... 1s.</p> <p>O No. 176. "TRANSFORMERS FOR TELECOMMUNICATIONS."—E. V. D. Glazier, Ph.D.(Eng.), A.M.I.E.E. 1940 ... 1s.</p> <p>O No. 177. "RECENT APPLICATIONS OF THE QUARTZ AND X-RAY SPECTROGRAPHS TO POST OFFICE PROBLEMS."—R. Taylor, M.A., Ph.D., B.Sc. 1941 ... 1s.</p> <p>O No. 178. "LONG DISTANCE D.C. IMPULSING."—S. Welch, M.Sc. (Eng.), and C. H. J. Fleetwood. 1942 ... 1s.</p> <p>O No. 179. "INTRODUCTION OF U.A.X. MULTIMETERING IN THE LEEDS AREA."—H. G. Cope. 1941 ... 1s.</p> <p>No. 180. "SUBSCRIBERS' CABLE DISTRIBUTION—SOME FURTHER CONSIDERATIONS."—F. Summers, A.M.I.E.E. 1944 ... 1s.</p> <p>O†No. 181. "POST-WAR EXCHANGE DESIGN."—H. E. Francis, A.M.I.E.E. 1943 ... 1s.</p> <p>†No. 182. "LONDON INLAND TRUNK SERVICES."—W. H. Scarborough, A.M.I.E.E. 1943 ... 1/6</p> <p>†No. 183. "FREQUENCY MODULATION."—J. H. H. Merriman, M.Sc., A.Inst.P., A.M.I.E.E., and R. W. White, B.Sc., F.Inst.P., A.M.I.E.E. 1945 ... 1/6</p> <p>†No. 184. "THE FUNDAMENTALS OF DIRECT CURRENT IMPULSING IN MULTI-EXCHANGE AREAS."—S. Welch, M.Sc.(Eng.), A.M.I.E.E. 1944 ... 1/6</p> <p>O†No. 185. "THE OPERATION OF VALVE OSCILLATORS AND THEIR SYNCHRONISATION."—A. C. Lynch, M.A., J. R. Tillman, Ph.D., and D. G. Tucker, Ph.D., A.M.I.E.E. 1944 ... 1s.</p> <p>O†No. 186. "TELEPHONE SERVICE OBSERVATIONS."—J. J. Perkins, A.M.I.E.E. 1945 ... 1s.</p> <p>†No. 187. "CABLING PROBLEMS IN SUBWAYS AND TUNNELS."—T. G. Turley, A.M.I.E.E. 1945 ... 1s.</p> <p>O No. 188. "POWER SUPPLIES FOR TELEGRAPHS."—G. N. Davison, B.Sc. (Eng.), D.I.C., A.M.I.E.E. 1945 ... 1/6</p> <p>†No. 189. "DEVELOPMENT OF TELEGRAPH SWITCHING IN GREAT BRITAIN."—J. A. S. Martin, A.M.I.E.E., and J. W. Freebody, Whit. Schol., B.Sc. (Eng.), D.I.C., A.M.I.E.E. 1944 ... 1/6</p> <p>†No. 190. "WIDEBAND TRANSMISSION OVER COAXIAL CABLES."—R. A. Brockbank, Ph.D., B.Sc., A.M.I.E.E., and C. F. Floyd, M.A., A.M.I.E.E. 1946 ... 1/6</p> <p>†No. 191. "PIEZO-ELECTRIC QUARTZ AND ITS USE IN TELECOMMUNICATIONS."—C. F. Booth, M.I.E.E., and J. L. Creighton, A.M.I.E.E. 1946 ... 1/6</p> <p>+No. 192. "THE LOCATION OF FAULTS IN LINES AND CABLES."—Capt. A. C. Tmmis, B.Sc., M.I.E.E. 1948 ... 1/6</p> <p>†No. 193. "IMPROVEMENTS IN TELEPHONE SIGNALLING."—S. Welch, M.Sc. (Eng.), A.M.I.E.E., and C. H. J. Fleetwood, A.M.I.E.E. 1949 ... 1/6</p> <p>†No. 194. "MAINTENANCE OF MULTI-CHANNEL CARRIER TELEPHONE SYSTEMS."—F. O. Morrell, B.Sc., A.M.I.E.E. 1948 ... 1/6</p> <p>+No. 195. "THE INTRODUCTION OF AUTOMATIC SWITCHING TO THE INLAND TELEPRINTER NETWORK."—H. E. Wilcockson, A.M.I.E.E., and C. W. A. Mitchell, A.M.I.E.E. 1949 ... 1/6</p>
---	--

\* For Officers of the Department only.

† The Council have awarded Institution Medals for these papers.

O Signifies out of print.