

RTTY THE EASY WAY

Fifth Edition
March 1985

Edited by Alan Hobbs, G8GOJ

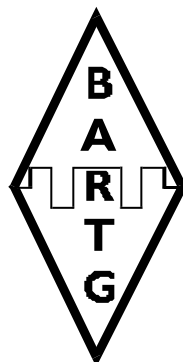

Copyright © 1985 British Amateur Radio Teleprinter Group
[originally] Printed by F.S. Moore Ltd., 38 Chancery Lane, London, WC2

Preface to the Fifth Edition

Since it was first introduced, "RTTY The Easy Way" has sold thousands of copies. The demand is still continuing, and in preparing this fifth edition the opportunity has been taken to incorporate many of the suggestions made by readers of previous editions.

There are three major additions in this fifth edition. First, the ST5 control board has been added; this will improve both the copy and the overall operation of the Terminal Unit. Second, there are details on how to connect the AMTOR MK2 unit to the ST5, and lastly there are some notes to help the computer user to get started on RTTY.

This has made it necessary to rearrange some sections of this booklet, which it is hoped will meet with the approval of our readers.

The ST5 Terminal Unit is proving as popular as ever, and full circuit and constructional details of the basic unit are included. However, there are now several variations of the ST5 available, notably the ST5MC for use with a teleprinter or computer, and the ST5C designed specifically for computer systems. Full information on these different versions is included in BARTG datasheets and with the instructions accompanying the kits and ready-built units supplied by BARTG. The group's magazine, DATACOM, contains details and prices of these items on the Shop Window page of each issue.

It is always easier to improve upon someone else's labour than it is to produce original work, and a great debt is owed to the editors and contributors to earlier editions, without whose efforts this fifth edition would not have been possible.

The British Amateur Radio Teleprinter Group is a non-profit organisation dedicated to helping members become active in RTTY and data communications in general. For full details of BARTG's many services, please refer to the centrefold in this booklet.

73

Alan Hobbs, G8GOJ

Editor

Notes on the electronic edition, 2005

This Adobe Acrobat® PDF version has been prepared by optical character recognition from a printed copy of the original, so may contain errors of transcription. Please notify any corrections by email to bartg@samhallas.co.uk. The diagrams have been scanned in without modification, but may not be true to size. Dedicated to the memory of Alan Hobbs, G8GOJ who died in April 2004.

Sam Hallas G8EXV

Introduction

The aim of this booklet is to provide sufficient information so that a newcomer to RTTY can get going with the minimum of tears - preferably none!

The information consists of recommended machines, how to connect and set them up, circuit and description of a basic Terminal Unit/AFSK oscillator, and hints of where to look for teleprinter signals.

A glossary is included to explain those terms which are peculiar to radio teleprinting.

Components of an RTTY Station

The minimum requirement for receiving and transmitting RTTY comprises five items:

1. Receiver
2. Transmitter
3. Terminal Unit
4. Keying circuits
5. Teleprinter (or computer)

The first two items will probably be part of existing station equipment, but please note the comments on RF equipment later in this booklet.

The Terminal Unit converts the receiver's audio output into positive and negative pulses which drive the teleprinter, and/or

changing voltage levels suitable for use with a computer/VDU system.

On the transmit side, RTTY signals initiated by pulses from the keyboard are generated either as audio tones or by direct frequency shifting of the oscillator in the transmitter.

Cost

A page printing teleprinter can be obtained for an outlay of between £5 and £40 depending on condition and vintage. However, be wary of scrap computer machines, as they usually use a different code from that used for RTTY.

As for the Terminal Unit, ex-commercial or government items can be purchased for £5 to £15, but it is advisable to construct this unit as most surplus equipments are not suited to current

amateur practice, and are generally inferior to what can be readily achieved with a home brew job.

For the TU described in this book, even if all the components are purchased brand new (i.e. no junk box digging), the total cost will only be about £60.

Ready made units, some specifically designed for the amateur market, can be obtained through advertisements in the various radio magazines, especially in BARTG's quarterly magazine DATACOM.

Machines

MODELS

As a machine for getting started with, the Creed Model 7 takes a lot of beating - it can take a lot of beating in other respects too!

Models 7B and 7E are the most common. Quite often the basic model number is followed by a suffix which indicates a variation in the design or an additional feature; e.g. 7E/RP is a 7E with a tape reperfing attachment..

Hence a suffix can enhance the usefulness of the machine. However, beware of the suffix RO on some models, as this is for a receive only machine and has no keyboard.

Also on the amateur market are models 54 and 75. The 54 is a very pleasant machine to use (it is something like a de-luxe version of the 7E), while the 75 is of a different design and mechanically complex.

In the case of both these machines, the advice of someone who knows the machine should be sought, as a large number of 54's and 75's were coded for computer use. The modification of a computer coded machine is a long and difficult task and not to be tried by the inexperienced. Another machine which has recently started to appear on the amateur market at reasonable prices is the Creed Model 444 (British Telecom Teleprinter 15). This is an excellent machine for the amateur RTTY station, and may often be found complete with a built-in tape reader and reperfing.

For all of these printers the steady state current through the magnet should be in the region of 20-30mA. Generally, teleprinter motors for use on

AC come in two types, governed and synchronous. The governed motor can be altered to the standard amateur speed of 45.45 bauds, but the synchronous motor cannot without extensive alterations to the machine.

In addition to Creed machines, some American and European machines appear from time to time. Common makes are Teletype, Lorenz, Kleinschmidt, Siemens and Olivetti. Most of them can be put into RTTY service but information and parts are limited so the beginner is recommended to obtain a Creed model.

Connections

For basic operation, the only connections that need to be made to the machine are for the motor, keyboard contacts and selector magnet. Usually the motor terminals, plus an earth, are brought out on a separate Lead and plug and are thus easily identified. However there are several different voltage ratings for the motors; the more common types are:

230V AC: Connect direct to the mains.

160/220V DC: Wire for 220V (adjustment Link is usually on the rear side of the motor) and feed

from the mains via a 1000PIV 1A bridge rectifier.

160V DC: Use half wave rectified mains or suitable transformer and rectifier (a mains to 350-0-350V transformer in reverse will do).

110V DC: Requires an appropriate transformer, rectifier, etc.

24V DC: Obtain or construct a 24V 4A DC supply - regulation is not critical, but the on-Load voltage should be between 23V and 26V.

The selector magnet can be considered as a polarised solenoid which operates firstly one way and then the other, according to the polarity of the applied DC signal, and the keyboard contacts as a single pole changeover switch.

Fig 1 shows a simplified schematic of a Model 7 together with the pin numbers of the most commonly used connectors.

Fig 1c defines a simple circuit for "Lashing up" a machine to get the keyboard to drive the printing mechanism.

Due to the large number of connections that are to be found on the 444 teleprinter, Fig 2 shows the complete signals wiring for this machine.

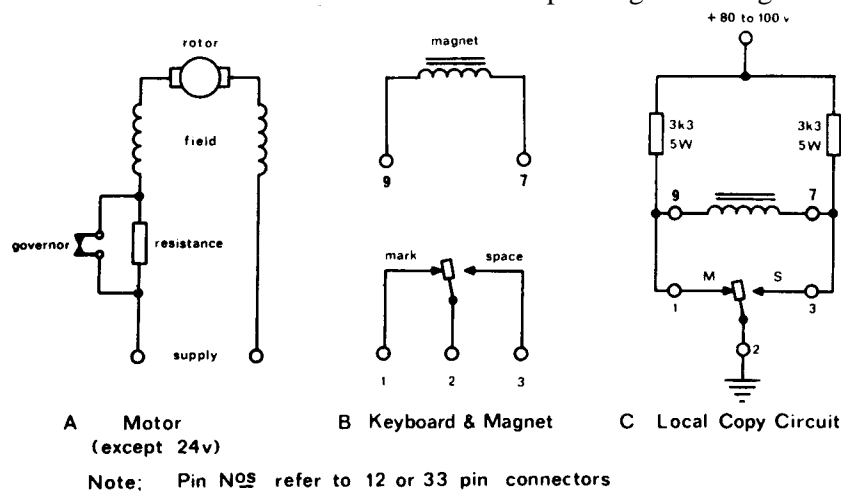

Fig 1: Teleprinter Schematics

Speed

Most Creed 7's are designed for a motor speed of 3000 rpm which corresponds to a teleprinting rate of 50 bauds. This is the speed used by most commercial transmissions, but as the majority of amateurs use a speed of 45.45 bauds it will be necessary to reduce the speed of the motor. This does not pose any great problem as a Model 7 governor can easily be adjusted to the lower speed of 2727 rpm. However, whichever baud rate is used it is necessary to devise some method of measuring the motor speed.

A freshly purchased machine therefore, unless the vendor was an amateur who had set it up for 45.45 bauds, should be first checked to see that it is running properly at 50 bauds by using the following method. Stick a piece of white adhesive tape about 0.25" wide from the centre of the governor face to the rim so as to give the appearance of a single "spoke". Start the motor and observe the face of the governor in a darkened room by the Light of a large neon lamp connected to the 50Hz mains. A two-bladed butterfly shaped fan will be seen. If the motor is running fast the fan will rotate in the same direction as the motor, but, if slow, in the reverse direction. Adjust the screw seen through the hole in the rim of the cover until the fan is stationary. The motor is now running at 3000 rpm.

The governor adjusting screw should now be turned 7.5 turns in an anticlockwise direction to reduce the speed to 2727 rpm for 45.45 bauds.

As an alternative to the mains neon method, a 125Hz stroboscopic tuning fork may be used. This looks like an ordinary tuning fork with two small plates screwed to the ends of the tines, each plate having a small slit in it.

When the fork vibrates, the slits come into line to produce a viewing aperture 250 times per second. For a suitably marked governor turning at the appropriate speed, the view through the aperture is a stationary display.

For 45.45 bauds the governor circumference needs to be marked out in 22 segments, 11 black and 11 white, whilst for 50 bauds the divisions are 5 and 5.

Whichever method of setting the speed is used a final check may be made by connecting the machine up for local copy as shown in Fig 1c and, whilst holding any letter key down, Lift the pawl abutment of the keyboard of the keyboard transmitter mechanism - this will cause the selected character to be repeated at cadence speed. (An alternative for RP machines is to press the Runout key). The machine should print 60 characters in 9.9 seconds at 45.45 bauds or 60 characters in 9 seconds at 50 bauds. The use of "press on" tachometers is not recommended except for very rough tests.

Note that the fact that a machine prints correctly on local copy is no evidence that the motor speed is correct - the motor being common to both transmitter and receiver.

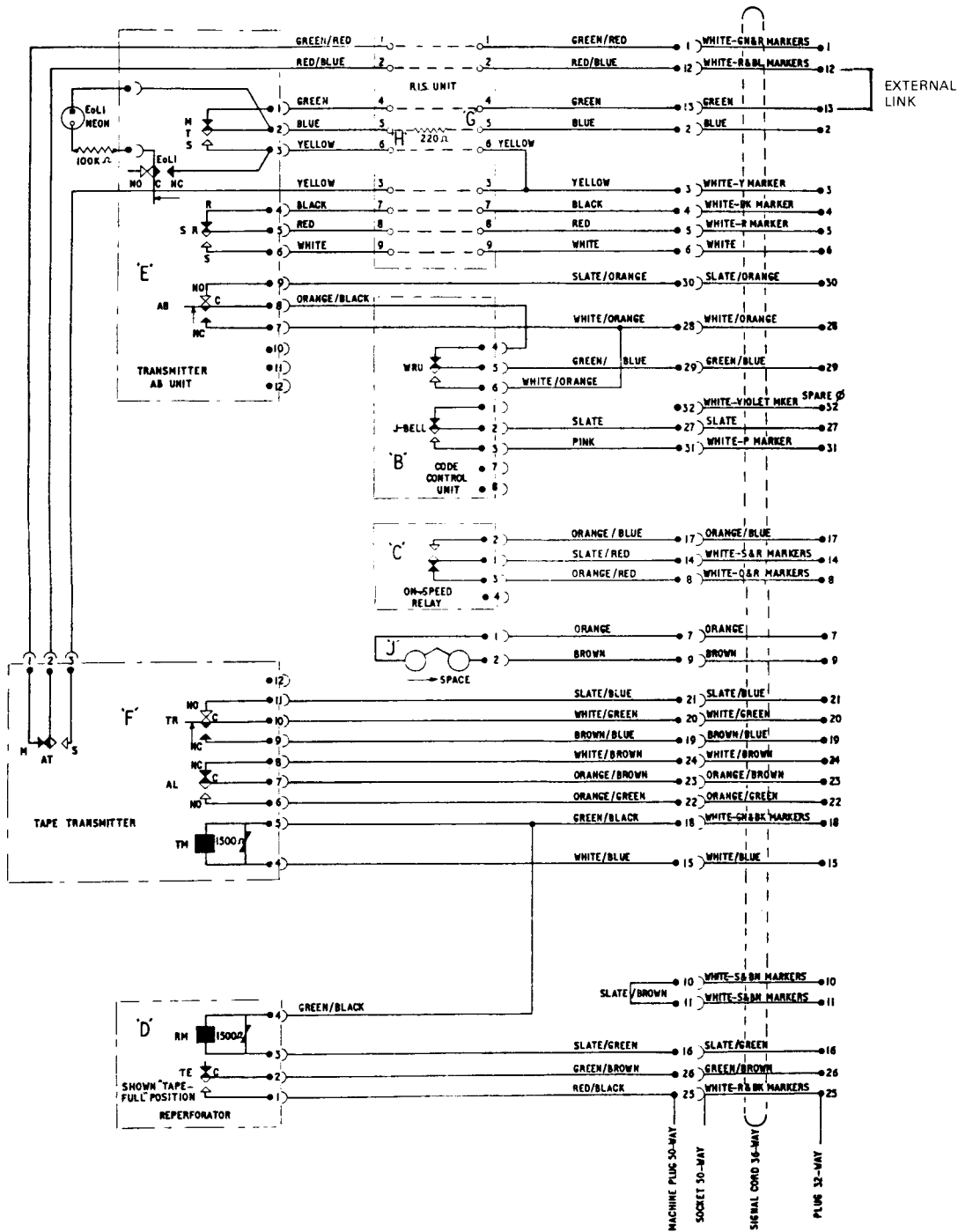

Fig 2: Creed 444 Connections

The Creed 444 on 45.45 Bauds

The Creed 444 Teleprinter was designed to run on either of two speeds: 50 bauds or 75 bauds. In addition, in order to remove the 'motor hash' or radio interference problems that are encountered with governed motors, the motor used on the 444 is usually of the synchronous type which produces no interference, but which is locked to the frequency of the mains.

To change a 444 from 50 bauds to 75 bauds it is necessary to change two gears. This is a simple job, particularly as the gears have been designed so that one gets smaller as the other gets larger, and so the centre-to-centre spacing remains the same, and no adjustments are necessary, except when the machine first leaves the factory.

The most widely used speed for HF working and for a lot of QSO's on VHF has for years been

45.45 bauds, but the problem is that Creed do not make gears for this speed. However, pairs of gears for 45.45 bauds have been made privately, and have been successful even though the extra number of teeth has made the larger gear teeth very fine. These gears can also be changed Like the others without adjustments. Unfortunately their cost has risen to over £25 per pair, and at this price there is little demand.

One solution which was arrived at independently by two or three groups was to use the existing 50-baud motor pinion and replace one gear only. This one gear had to be specially designed, as the teeth angles are different to mesh with

the 50-baud pinion, and as it must have 44 teeth of a set size the finished diameter is slightly larger than the 40-tooth 50-baud gear it replaces. Thus a small adjustment is needed, which will take you two minutes once you know how to do it. Thus all you need to do is to purchase one gear which currently costs around £10.00 - this compares favourably with the 50-baud gear it

replaces. Your machine must, of course, be on 50 bauds already, or you will need a 50-baud pinion.

EXAMINING THE 444 AND FINDING OUT WHAT SPEED IT IS ON

Stand in front of the machine, Lift the cover and locate two chrome screws in the top side edges of the grey cabinet. Turn these 90 degrees, remove the paper winder knob from the left-hand side, and lift off the whole top of the machine cabinet.

Now turn the machine around so that you are standing behind it. Locate the grey diecast box, which is the motor assembly and which has the drive shaft coming out on your Left hand side. Remove a red plastic dust cover from over the gears immediately to the Left of the motor. This will expose a small black gear which is the motor pinion, and a larger 'nylon' or composite nylon/aluminium gear. Remove a 48A bolt in each gear, and so remove both gears. Count the teeth, and hence determine the speed from the table on the next page.

Baud Rate (Speed)	Number of Teeth: Motor Pinion	Number of Teeth: Gear
75	9	30
50	8	40
45	9	50
45.45	8	44

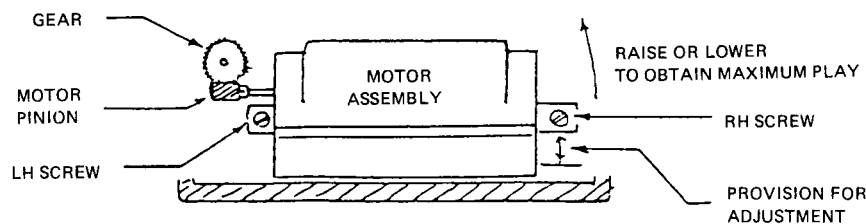

Fig 3: 444 Motor viewed from the rear

FITTING INSTRUCTIONS FOR USING THE SINGLE GEAR WITH 44 TEETH

Having confirmed that the machine is in working order and already on 50 bauds, remove the paper winder knob from the left-hand side, turn two chrome screws in the top edge of the sides of the cabinet through half a turn and lift off the top half of the machine cabinet.

Now turn the machine around so that you are behind it. Locate the grey diecast box that is the

motor assembly and find the two large securing screws that hold this assembly to the main chassis of the machine. You will also find provision for adjustment just below

the right-hand securing screw, but leave this for now.

Remove the red dust cover from over the gears on the left-hand side of the motor. Locate the 4BA bolt in the larger 40-tooth gear. Undo and

remove this gear. Leave the existing 8-tooth motor pinion on the motor shaft.

Referring to Fig 3, now undo the Large securing screw on the Lefthand side about two turns. Also undo the large right-hand securing screw about the same amount. Insert your screwdriver between the adjusting screw and casting on the right-hand side, and so lift the right-hand side of the motor

assembly about a quarter of an inch. You now have room to slide on the slightly Larger and tougher 44-tooth gear. Do this and secure with the 4BA screw.

THE ADJUSTMENT - Let the right-hand side of the motor assembly go back towards its original position. Hold the Larger gear in your left hand and rock the gear backwards and forwards - there will be no play. Try Lifting the right-hand side of the motor assembly and rock the gear again. There will be a clonk-clonk as there is some play or clearance. Tighten the Large securing screws a small amount and raise or Lower the

right-hand side of the motor assembly to detect the barest possible play, then secure the screws. Leave the adjusting screw setting on the right-hand side as it was, in case you want to return to 50 bauds.

RETURNING TO 50 BAUDS - Remove the 44-tooth gear, replace the 40-tooth gear, undo the Left-hand Large screw two turns, and undo the right-hand Large screw. There will be a clonk as the motor assembly falls back to its original position. Tighten the securing screws and you are back on 50 bauds.

Further Reading

"TELEPRINTER HANDBOOK" 2ND EDITION By A. Hobbs G8GOJ, E. Yeomanson G3IIR and A. Gee G2UK, written on behalf of BARTG and published by the RSGB - the "standard" radio teleprinter book in the UK and a must for all serious enthusiasts.

"TELEGRAPHY"

By J W Freebody. For years this was the classic teleprinter textbook but it does not cover the adjustment of machines. Can usually be obtained through a local library.

"TELEGRAPHY"

By R N Renton. This is a revised edition of Telegraphy by Freebody, incorporating modern techniques and equipment.

"DATACOM"

Sent quarterly to all BARTG members, contains technical articles, contest rules and results, activity and gossip columns, sales and wants adverts (no charge to members) and all aspects of RTTY news and information.

Tape Readers

More commonly known as automatic transmitters or simply as autos, these machines are used for reading punched paper tape. The usual function of such machines in an amateur station is to remove the tedium of typing out frequently used messages; e.g. CQ calls, station details etc.

An auto is also an integral part of a station where "punch-on-line" mode is used - this is where an operator prepares a reply tape while the far station is transmitting.

There are several models of tape reader in use in the UK but by far the most common is the Creed 6S series ranging from the Model 6S through 6S2 to 6S6M (Post Office numbers are 18, 1C, 2C to 2F). Typical machine cost is £5 - £12:

Electrically, the signal circuits of a 6S behave identically to those of a Model 7 keyboard; i.e. a single set of changeover contacts. In addition, some machines (those with an "M" in the model number) require a 50V 20mA DC supply to operate an electromagnetic clutch. Thus the simplest arrangement consists of a

single changeover switch in the signal Leads from the keyboard and auto.

Alternatively, a more flexible configuration is given in Fig 4a, one of the positions providing a means of transmission from the auto without taking local copy - there being little point in printing one's own CO calls every time.

For magnetic clutch machines, Figs 4b and 4c provide the wiring information: 4b for the 33-pin and 4c for the 12-pin connectors. The components R23, R24 etc in Fig 4a refer to the BARTG ST5 Terminal Unit; see Fig 6.

Some 6S6 tape readers were fitted with a gearbox and a changeover Lever which provided either 50 or 75 baud transmission.

The Later 6S series machines normally run at 1500 rpm for 50 bauds, but have an adjustable governor and so can be easily reset to 45.45

bauds by using a 125Hz tuning fork and 11 black + 11 white segments, as described earlier in the section on SPEED.

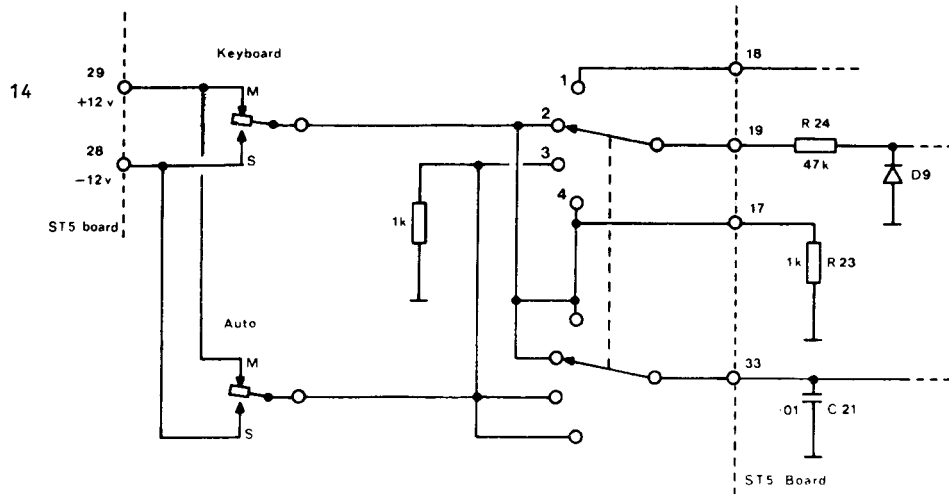

Switch arrangements

1. Rx (and Tx from Kb for duplex)
2. Tx from Kb with local copy
3. Tx from Auto with local copy from Auto
4. Tx from Auto with local copy from Kb

Fig 4a: An Auto Configuration

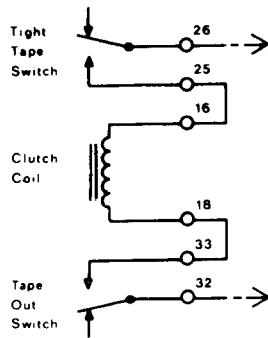

Fig 4b: 33-pin Connections

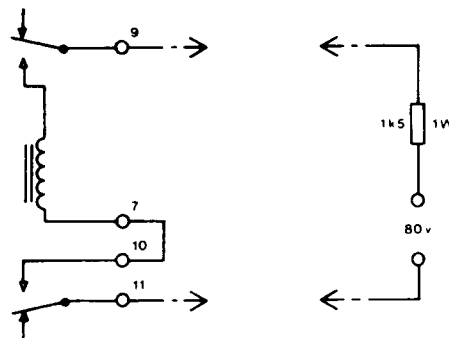

Fig 4c: 12-pin Connections

Radio Interference

This is a very individual problem in that the amount of RF interference varies greatly from motor to motor and that two solutions never seem to be the same. The first step is to listen to all the bands that are to be used while the motor is running to see if there is a problem at all - a quiet motor is best left well alone.

Should RFI prove to be a problem, some of the following suggestions may result in a remedy, or at Least an improvement:

1. Clean the governor contacts using emery paper and reset the gap to

0.020-0.025 inches. Only use a file if the contacts are badly pitted.

2. Clean the governor slip rings - use Brasso, Brillo pad, fine wire wool etc.
3. Clean the commutator using fine emery paper and then thoroughly swill out with spirit but be careful not to overdo it as the insulation may suffer.
4. Wire a disc ceramic capacitor (0.01uF 1KV) across the governor brushes and fit small ferrite cored chokes (tv suppressor types) in the

- Leads between the brushes and the existing governor filter.
5. Replace the capacitors inside the motor with disc ceramic components. Wire the new capacitors across the brushes and between each brush and the motor chassis. At this point, if there is enough room, fit small chokes (as per governor) in the leads between the brushes and the field windings.
 6. If the machine has any kind of metal silence or dust cover, ensure that the machine chassis, cover and base plate are all soundly earthed; use short Lengths of copper braid.
 7. For ground level stations, place a Large sheet of metal, grid or foil on the floor (under the carpet etc) to form a capacitance to earth. Connect this to the teleprinter chassis by as short a Lead as possible - wide copper braid or strip is most suitable.
Do not forget to connect the sheet to mains earth as a safety measure.
 8. If not already in use, employ an isolation transformer between the mains and motor.

9. Use a screened cable between the TU and the teleprinter and include small decoupling capacitors.
10. Use coax to feed the aerial and site the aerial and radio as far from the teleprinter as possible.

Terminal Unit

BASIC PRINCIPLES

Fig 5 shows a block schematic of a Terminal Unit (TU). Audio from the receiver is fed to a limiting amplifier which converts the signals into constant amplitude square waves; this takes care of fading of either one or both of the tones. The cleaned-up signal is passed through a discriminator which changes the frequency difference of

the tones into two DC voltages, typically -3 volts for Mark and +3 volts for Space. The dicer stage, being a high gain DC amplifier, merely decides whether the discriminator output is positive or negative and gives out a well defined signal level (+10 volts Mark, -10 volts Space). Finally the magnet driver converts the dicer signals into suitable drive levels for the teleprinter electromagnet.

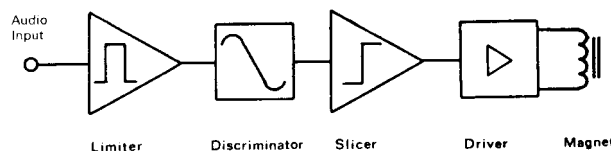

Fig 5: ST5 Block Schematic

CIRCUIT DESCRIPTION

The complete circuit, based on the very successful ST5 design by Irv Hoff, W6FFC, is shown in Fig 6. It contains all the features necessary to get reliable copy from RTTY signals, and gives the precise circuitry of the printed circuit board as available from BARTG, including components for tuning scope connections and power supplies.

The Limiting function which removes noise and fading is performed by IC1, a 709 operational amplifier. This device is capable of full Limiting with less than one millivolt of signal and yet can

recover from overload conditions within a few microseconds - protection from severe overload voltages is achieved by diodes D1 and D2.

The frequency discriminator circuit

uses two 88mH inductors (telephone line loading coils or pot cores) with appropriate resistors and capacitors to give a linear frequency-to-voltage characteristic. Audio ripple content in the output is minimised by the use of full wave detectors and is removed by a simple RC low pass filter.

Diodes D3 and D4 provide a metering signal for tuning - the meter used in the ST5 does not

readily respond to HF noise and is also used to help in aligning the ST5.

Because some signals will be received "upside-down" (i.e. the tones reversed), S1 is included as a means of correction. Its two positions are N (Normal) and R (Reversed).

A second operational amplifier, this time a 741 type, performs the slicing (decisive switching) action. The 741 has more than enough gain for the job and is also short circuit proof.

Creed teleprinters require polar current drive for the selector magnet - for this reason, the slicer signals are fed via a phase sputter (42, Q3) to a high voltage bridge circuit (44, Q5). The bridge is

operated at the extremes of imbalance such that the maximum current flows through the magnet coil either one way or the other, the current drive being provided by the high voltage and high resistances (3K3).

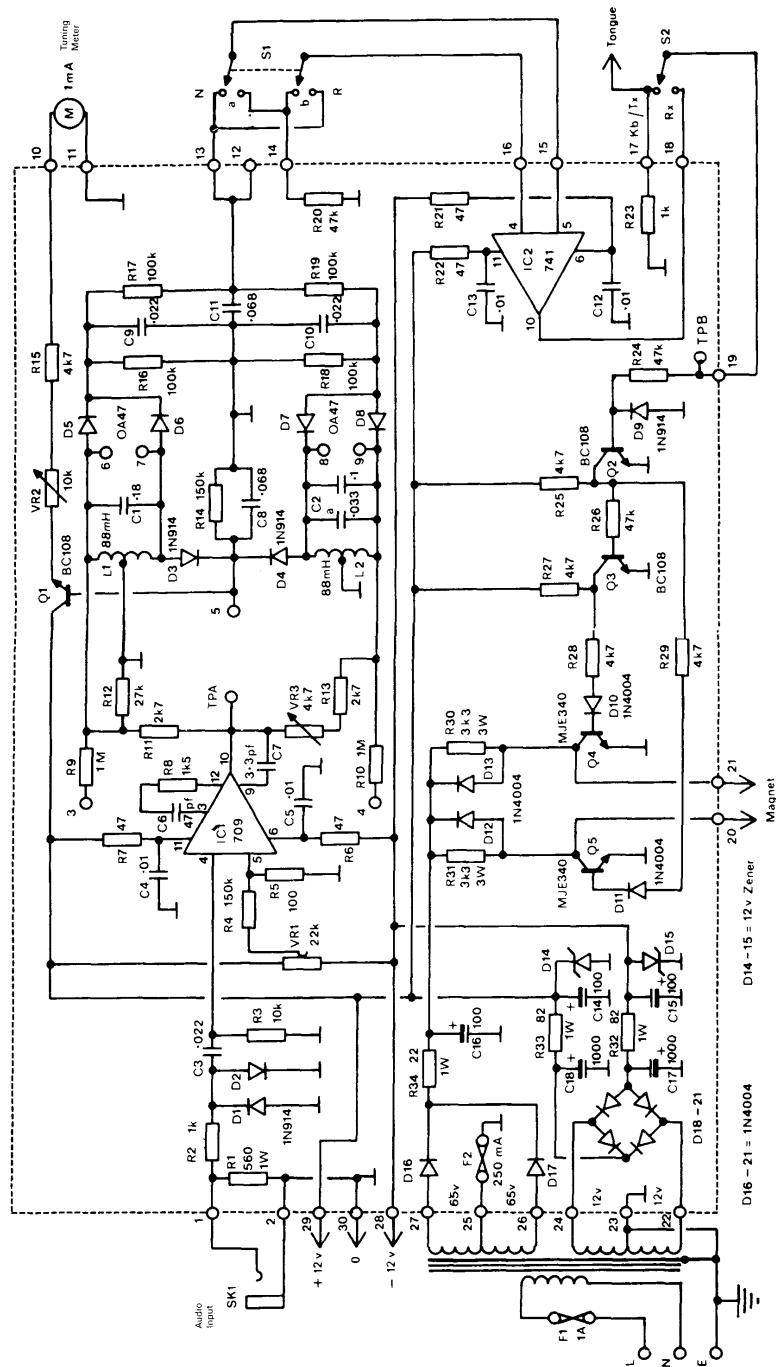

Fig 6: ST5 TU Schematic

The diodes in the bases of Q4 and Q5 perform a dual function - in the first place they create a higher threshold point for the switch-on of the driver transistors, and in the second place they isolate the low voltage circuits from the 80 volt rail in the event of component failure.

local copy is achieved by substituting the slicer signals with similar signals derived from the keyboard. Switch S2 also provides a means of isolating the selector magnet from the receive circuits while signals are being tuned in.

Layout of the TU is not critical. The only precaution needed is to keep the Leads to and from S1 fairly short, preferably less than two inches.

Note that if open toroids are used, the windings must be connected in series, the joint between the windings providing the centre tap.

AFSK Oscillator

Note: This item only need be constructed by those intending to transmit with a sideband rig on HF or with either a sideband or FM rig on VHF.

Referring to Fig 7, Q6 and Q7 form a multivibrator naturally oscillating at the Space frequency (1275Hz) but

which can be switched to Mark (1445Hz) by transistor Q8.

The essentially square wave output of the oscillator is filtered by a fourth order active circuit (Q10 and Q11) to produce a near sine wave signal at SK3. Output level can be varied up to 150mV by VR6.

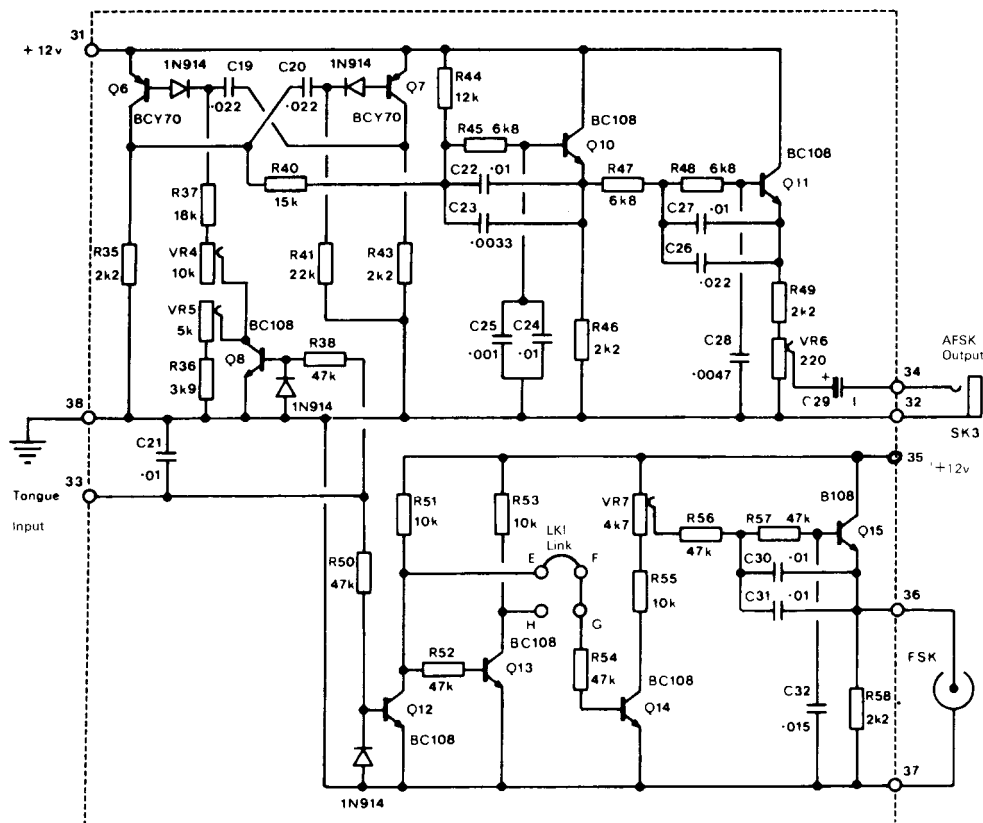

Fig 7: FSK/AFSK Schematic

FSK Circuits

An alternative method of generating an FSK RTTY signal is to apply shift control voltages to the oscillator in the transmitter. The circuits of Fig 8 can be applied to most VFO's to produce acceptable FSK. For crystal oscillators, the shift

components (D and VC) should be wired directly across the crystal.

The principle of the circuit is that diode D, a reverse biased silicon device, acting as a variable capacitor, alters the total capacitance of the oscillator tuned circuit between two set limits. (Purpose made devices such as the BA111 can be

used; alternatively, a power diode such as the BY106 can be used). Abrupt transitions between these limits are prevented by the 2pole active filter constructed around Q15. (See Fig 7).

By convention, the radiated signal should have its Mark frequency HF of its Space - if the signal turns out to be "upside-down", simply change link LK1 to H-G. Shift setting is achieved by adjusting VR7 and VC.

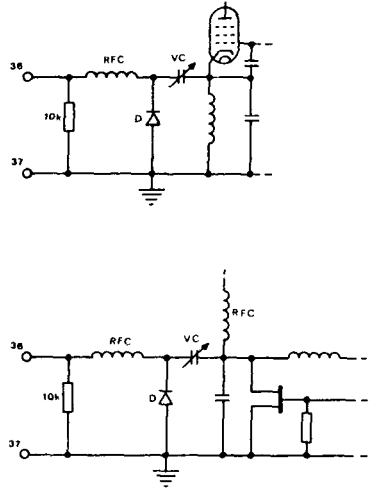

Fig 8: FSK Circuits

Construction

With the exception of the wiring to and from S1 (Fig 6), neither the layout nor the method of construction is critical, hence any of the common construction methods such as matrix board, Veroboard etc, may be used.

The most "sure-fire" approach is to use ready made printed circuit boards - such boards are available from BARTG. The following construction notes refer to the use of the BARTG boards.

Referring to Fig 11, insert the two wire Links (alongside VR1 and among D14, D15, C17 and C18) and all

terminal pins (total of 32 including the two test points). Fit and solder all components, observing the following points:

1. L1 and L2 - for pot cores such as the 3AF types, secure to the board using an epoxy resin; e.g. Araldite. For "open" toroids, some form of resilient mounting is required - a small rubber foot or grommet can achieve this as shown in Fig 9.

The centre tap connection for the 3AF cores is made by strapping the white and the red/white leads together, and by earthing them.

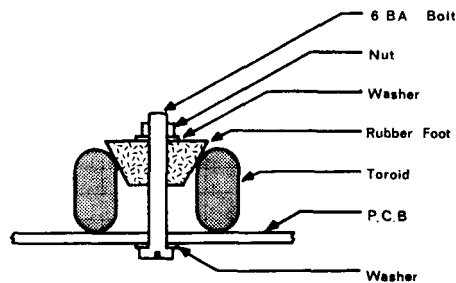

Fig 9 Toroid Mounting

2. IC1 and IC2 - it is recommended that 14-lead Dual-in-Line (DIP) devices be used as there is minimum risk of them being mounted incorrectly. If short form

DIL (8Lead) or TO-99 (sometimes known as 8-Lead TO-5) packages are to be used then they can be fitted as shown in Fig 10. DIL sockets can be used.

3. Q4 and Q5 - no heat sinks are required so these transistors are simply mounted vertically on their terminal Leads. Note that the emitters are nearest each other, hence the exposed metal surfaces (for MJE340 transistors) face in the directions indicated by Fig 11.
4. R30 and R31 - these resistors dissipate two watts and should be spaced 5 mm from the surface of the board to avoid scorching the PCB.

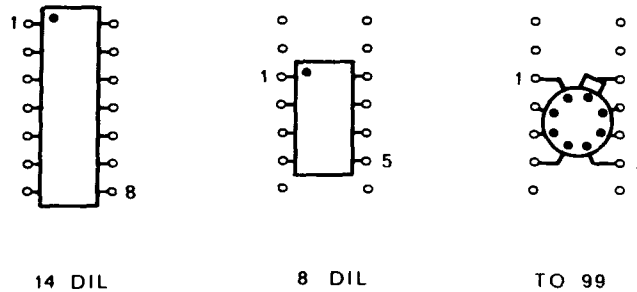

Fig 10: Alternative IC packages (top views)

Any case with internal dimensions in excess of 11 x 8 x 3.5 inches will suffice, although an earthed metal box should be used where the unit is to operate in the vicinity of a transmitter. Fig 13 shows an arrangement for a common size of diecast box.

and 6 mounting holes for the printed circuit board and the two for the mains transformer. Then mount the Large PCB, mains transformer, meter sockets, switches, fuseholder and mains Lead in that order. Do not fit the small PCB until the TU board has been adjusted.

First drill the holes for S1, S2, the meter, mains lead, fuseholder, FSK output, SK1, SK2, SK3,

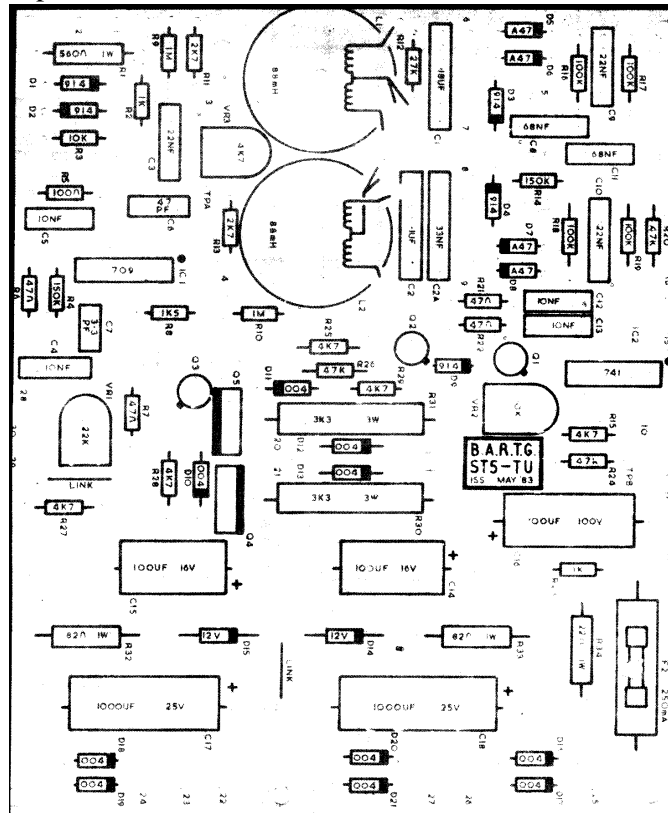

Fig 11: ST5 Terminal Unit Printed Circuit Board Component Layout

Alignment

Once the PCB has been constructed and checked for correct component placement (Fig 11), dry joints etc, wire the board as per Fig 14 omitting all connections to the FSK/AFSK board.

Referring to the schematic in Fig 6 and the inter-unit wiring diagram of Fig 14, the alignment procedure is as follows:

1. Short the input jack SK1 and connect a DC voltmeter between TPA and terminal pin 30 (earth). Adjust VR1 so as to attempt to get a zero voltage reading - this may not be possible as the meter will probably swing sharply from one extreme to the other over a very short travel of VR1. If this happens get it as near as possible and Leave it. Remove the input short and disconnect the voltmeter from TPA.
2. If an audio oscillator and frequency counter are available, tune the discriminator as described below; if not then proceed to step 4. Feed in a Space signal (1275Hz) at SK1, any level between 10mV and 1V, and tune L1/C1 for a peak reading on the tuning meter, altering VR2 for a convenient reading as necessary. L1/C1 can be brought to resonance by changing the value of the capacitor C1.
3. Repeat the tuning process for L2/C2 using a Mark tone of 1445Hz.
4. Feed in a Space signal (1275Hz) either as per step 2, or if steps 2 and 3 were omitted any variable frequency audio tone; e.g. a clean beat note from a receiver. However, be careful not to select a subharmonic as 425Hz and 482Hz will produce significant deflections on the meter. Vary the frequency of the audio signal for a peak reading on the meter and adjust VR2 for a convenient setting, say 70% of fullscale.
5. Feed in a Mark signal (1445Hz) and vary the frequency for a peak reading. Adjust VR3 for the same reading as in step 4. Repeat steps 4 and 5 until both readings are the same.
6. Plug the teleprinter into SK2 and switch S2 to KB (Keyboard). With the motor running, check that TPB is positive - it should be at Least 9 volts - if it is negative, change over terminals 2 and 4 of SK2.
7. With the motor running, the printing mechanism should be stationary - if it is "racing", change over terminals 1 and 5 of SK2.

With all the above steps completed there should be little need to make any further adjustment for a long time.

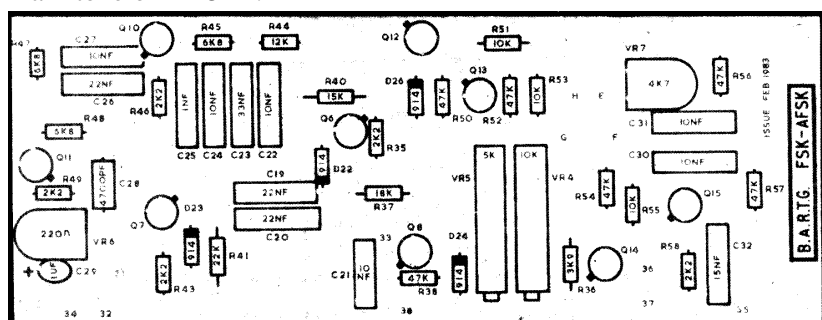

Fig 12: FSK/AFSK Printed Circuit Board Component Layout

FSK/AFSK Board

For a receive-only unit this part need not be wired at all. Similarly, if, say, the AFSK oscillator is not required then all the AFSK components can be omitted, or the FSK parts can be omitted if the outgoing tones are to be fed to the microphone socket of the transmitter .

Insert the terminal pins. Mount and solder all the components including the Link between E and F (Fig 7).

It is recommended that multi-turn trimpots be used for VR4 and VR5. However, the printed circuit has been designed to accommodate either the trimpots or a pair of the cheaper skeleton presets.

AFSK Alignment

Having checked the PCB has the components in the correct places (Fig 12) and good soldered joints, mount the board in the diecast box - using 1 inch 68A tapped pillars with insulating washers - and make all the remaining interconnections between the two boards and the external components (see Fig 14).

Switch the oscillator to Mark by disconnecting the teleprinter from SK2 and shorting terminals 3 and 4 on SK2. Adjust VR4 for an output

frequency of 1445Hz. Remove the short and adjust VR5 for 1275Hz.

If no frequency counter is available, then either beat the signal against known accurate 1275/1445Hz tones or, as a Last resort, connect SK3 to SK1 and adjust VR4 and VR5 for peak readings on the TU tuning meter.

Finally adjust VR6 for a convenient output level - see also the section on "RF Equipment - Transmitters".

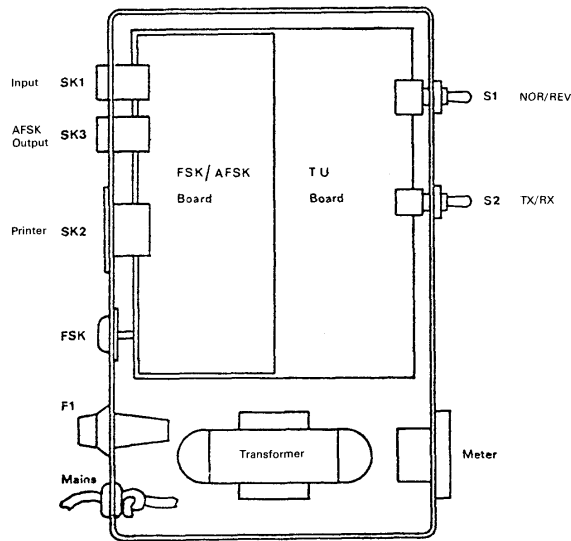

Fig 13: Typical Case Layout

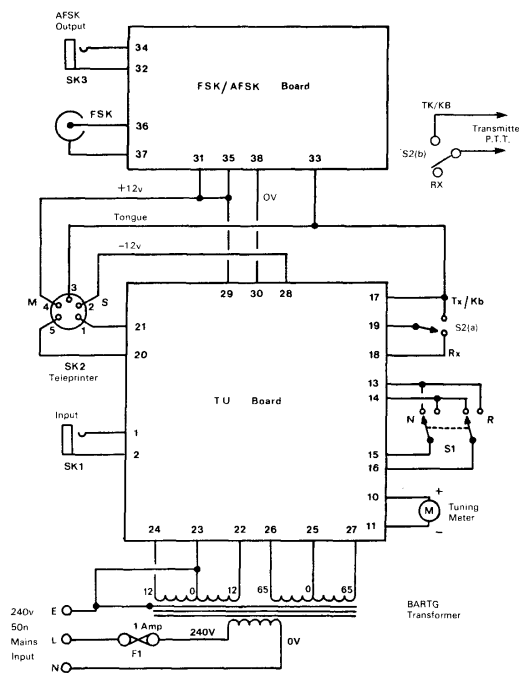

Fig 14: Inter-unit Wiring

ST5 Components List

SEMICONDUCTORS

	Description	Circuit
709C	operational amp	IC1
741	operational amp	IC2
BC108	transistor - npn	Q1,2,3,8,10,11,12,13,14,15
BCY70	transistor - pnp	Q6,7
MJE340	transistor - npn	Q4,5
1N914	diode - silicon	D1,2,3,4,9,22,23,24,26
1N4004	diode - silicon	D10,11,12,13,16,17,18,19,20,21
BZX61	12v Zener diode	D14,15
OA47	diode - germanium	D5,6,7,8

CAPACITORS

	Description	Circuit
3.3pF	ceramic plate	C7
47pF	ceramic plate	C6
1000pF	polystyrene	C25
3300pF	polystyrene	C23
4700pF	polystyrene	C28
10nF	25V disc ceramic	C4,5,12,13,21
10nF	5% polycarbonate	C22,24,27,30,31
15nF	5% polycarbonate	C32
22nF	5% polycarbonate	C3,9,10
22nF	5% polycarbonate	C19,20,26
33nF	5% polycarbonate	C2a
68nF	5% polycarbonate	C8,11
100nF	5% polycarbonate	C2
180nF	5% polycarbonate	C1
1uF	35V tantalum bead	C29
100uF	25V electrolytic	C14,15
100uF	100V electrolytic	C16
1000uF	25V electrolytic	C17,18

PRESETS

220	Skeleton	VR6
4K7	Skeleton	VR3,VR7

5K	Multiturn	VR5
10K	Skeleton	VR2
10K	Multiturn	VR4
22K	Skeleton	VR1

RESISTORS - all 1/4 watt unless stated otherwise

22	1W	R34
47		R6,7,21,22
82	1W	R32,33
100		R 5
560	1W	R1
1K		R2,23
1K5		R8
2K2		R35,43,46,49,58
2K7		R11,13
3K3	3W	R30,31
3K9		R36
4K7		R15,25,27,28,29
6K8		R45,47,48
10K		R3,51,53,55
12K		R44
15K		R40
18K		R37
22K		R41
27K		R12
47K		R20,24,26,38,50,52,54,56,57
100K		R16,17,18,19
150K		R4,14
1M		R9,10

INDUCTORS:

88mH open toroid or pot core L1,L2 See note

MISCELLANEOUS

Mains Transformer See note

P.C. Boards (2 off) See note

Meter, 1mA, Switches, plugs, sockets, fuseholders, case, hardware, etc.

NOTE

Mains transformer, toroids, pot cores and printed circuit boards are obtainable from the British Amateur Radio Teleprinter Group. (Members of BARTG qualify for discounts on these items). For ordering details, see the current issue of DATACOM.

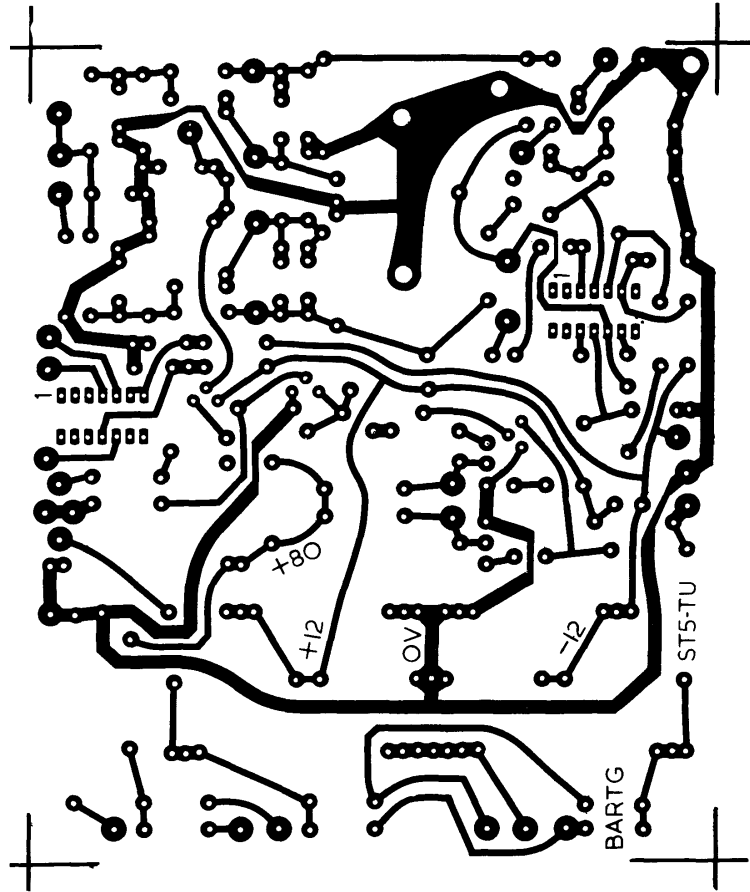

Fig 15: ST5 Terminal Unit Printed Circuit Track Layout

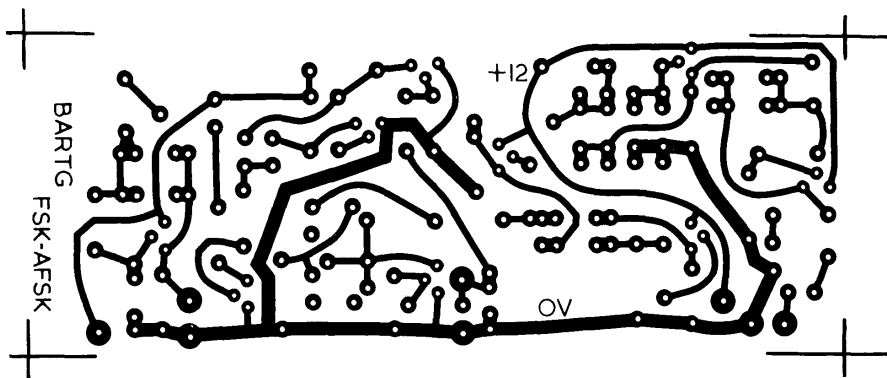

Fig 16: FSK/AFSK Printed Circuit Track Layout

Tuning Scope Connections

Even though a tuning meter has been included in the circuits described so far, a CRT indicator will be found to be a worthy addition. The oscilloscope need not be at all special - a simple XY display with a sensitivity of a few volts per centimetre being all that is required. All necessary terminals are provided on the PCB layout, and two configurations are offered.

Fig 17a is the simplest, producing a crude "cross" display, but is somewhat limited for narrow shift

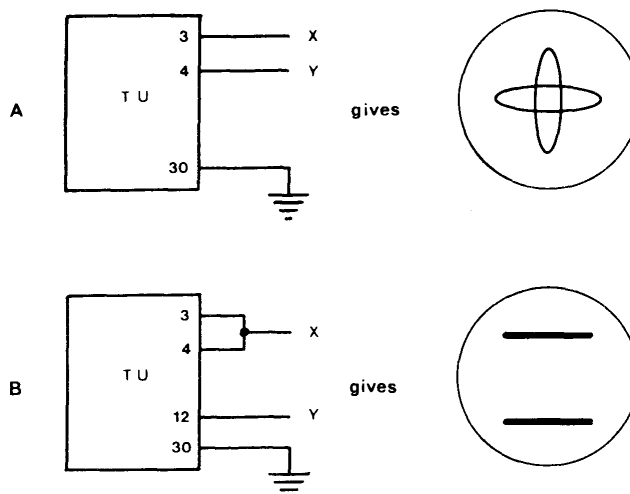

Fig 17: Tuning Scope Connections

Some readers may own and wish to use a CRM-1 indicator (the CRM-1 is the CRT indicator part of the FSY.1.1 system). Simply connect terminal 12 of the PCB to pin 1 of PL2 of the CRM-1, and make an earth connection between the units (terminal 30 PCB to pin 4 of PL2 CRM-1). Please note that CRM-1 indicators are no longer available on the surplus market although they may turn up from time to time in "small ads" or junk sales.

A novel approach to the problem of tuning an RTTY signal led to the development, by Tony Oakley, G4HYD/5Z4DJ, of the Toni-Tuna. This

is a versatile audio frequency tuning meter, utilising an LED bargraph display, which indicates the frequency to a resolution of 10Hz, and being totally electronic gives a near instantaneous readout. For further information on

signals. The "flipping Line" display of Fig 17b will be found easier to use but it does require a DC-coupled Y amplifier in the oscilloscope - the object is to tune the signal so that the two horizontal Lines are of equal length and equidistant from the centre of the display. An additional advantage of the flipping line arrangement is that by replacing the X signal with a 140ms timebase, the signal waveform can be observed.

the ToniTuna, the reader is referred to BARTG Datasheet No 1. For ordering details see the current issue of DATACOM.

Whichever indicator system is adopted, a little practice on Live signals will soon educate the user how to tune in signals to get the correct display.

TTL Interface

If it is required to convert the demodulated teleprinter signals into TTL levels, e.g. for connection to a visual display unit (VDU), electronic speed converter or

computer, then the circuit in Fig 18 may be used.

Note that the resistor is fed from +5V and NOT +12V.

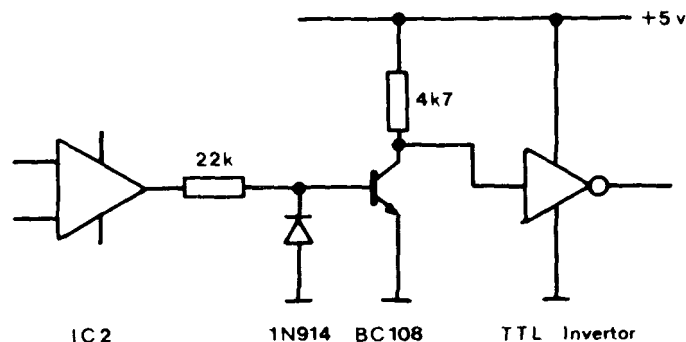

Fig 18: TTL Interface

Using the 75 Teleprinter

ALL transmitting versions of the Creed 75 regenerate telegraph signals; i.e. any incoming signals at the selector magnet are reproduced at the transmit (keyboard) contacts.

If there is an electrical connection between the keyboard and the magnet - as in the BARTG design - then an electro-mechanical "feedback" situation can occur. Magnet signals are mechanically coupled to the transmit contacts which are then fed back via the Terminal Unit to the magnet. The net result is that the machine goes into an oscillatory condition, printing the same character ad infinitum.

Some machines are fitted with a mechanical device for inhibiting this condition but even

when this is fitted the adjustment is rather critical and therefore not recommended. Fortunately; the Creed 75 obtains its local copy entirely by mechanical means and therefore does not require the electronic connection.

The solution is to break the circuit within the Terminal Unit but at the same time maintain the appropriate connections to the FSK/AFSK generators.

Fig 19 shows the modifications required to the inter unit wiring. (See Fig 14). Note the extra connection from S2 to the +12V supply (terminal 29). This is necessary to hold the magnet in the Mark condition when S2 is switched to "TX/Kb".

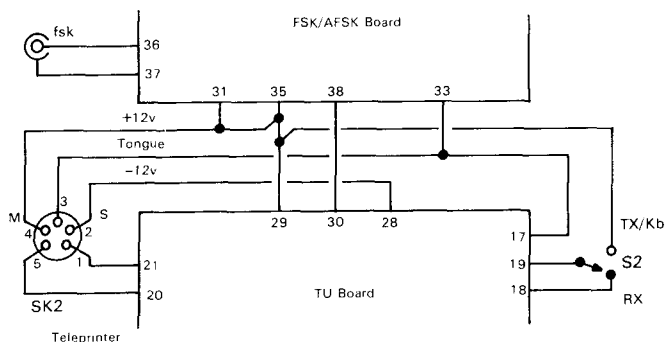

Fig 19: Inter Unit Wiring Modifications

Band Pass Filter

A pre-Limiter bandpass filter can be a particularly worthwhile addition to a Terminal Unit when taking copy on the crowded HF bands.

Fig 20 gives the circuit of a filter suitable for 1275/1445Hz tones, either as an "add-on" unit (Fig 20a) or as an integral part of the Terminal

Unit (Fig 20b). Alignment is straightforward and only requires an accurately calibrated audio oscillator (or oscillator and counter) and a high impedance AC voltmeter (or DC voltmeter and diode probe).

First short out L3 and L5 and connect the oscillator via a 47K resistor across L4 - see Fig 20c. Find the resonant frequency of the centre tuned circuit (peak reading on meter) and then

alter the value of the 0.11uF capacitor as necessary to bring this resonance to 1360Hz.

20b) and repeat the resonance procedure for L3 and L5.

Remove the shorts and place a single short across L4. Disconnect the input and output resistors (3K3 and 3K0 Fig 20a, 3K3, 3K6 and 4K7 Fig

Remove the short, reconnect the resistors - alignment is then complete.

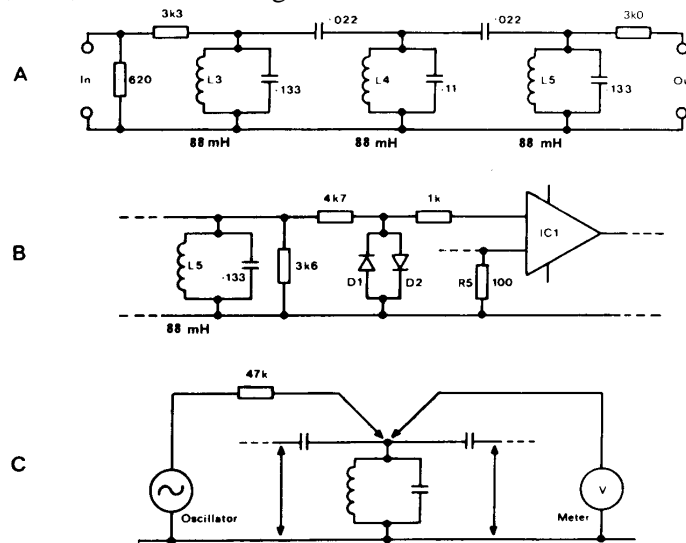

Fig 20: Pre-limiter Bandpass Filter

Single Current Output

The question has been raised as to whether the BARTG version of the ST5 Terminal Unit can be modified for single current output. Strictly speaking, this is not practical, as most single current machines require 40/60mA from a 120V supply, for reliable operation. Something of a compromise can be reached with the existing 80V supply, and, as it is mainly a matter of omitting components, it becomes worth trying.

The changes required are:

1. Omit R29, R30, D11, D13 and Q5.
2. Change R31 to 1K8 with a rating of at Least 6 watts.

The selector magnet of the single current machine remains connected to terminals 20 and 21 of the main ST5 printed circuit board.

Amtor MK2 to ST5 Connections

A suggested circuit to Link an AMTOR Mk 2 Unit to the ST5 is shown in Fig 21. ALL transistors except QX and QY are type BC108 or

similar. Diodes are small signal silicon type 1N914.

The only change to the ST5 is to break two connections, indicated by 'X' on the diagram. Connections not shown as modified remain as before; e.g. pin 17 still goes to SK2 pin 3 and to switch S2.

Three alternative connections, 'A', 'B' and 'C', (shown at the bottom of the diagram) are provided for PTT control, depending on the

transmitter. If the transmitter has positive PTT switching relative to ground, connection 'B' can be used - 'B' will sink 40mA max at 30V max. If the transmitter needs more than either 40mA or 30V, use connection 'A' and select a suitable NPN transistor for QX.

If the transmitter has negative PTT switching relative to ground, use connection 'C' and select a suitable PNP transistor for QY. Lower the value of the 1K resistor if more than 10mA is required. If connection 'C' is used it would be better to use a +12V supply which is independent of the ST5 supply.

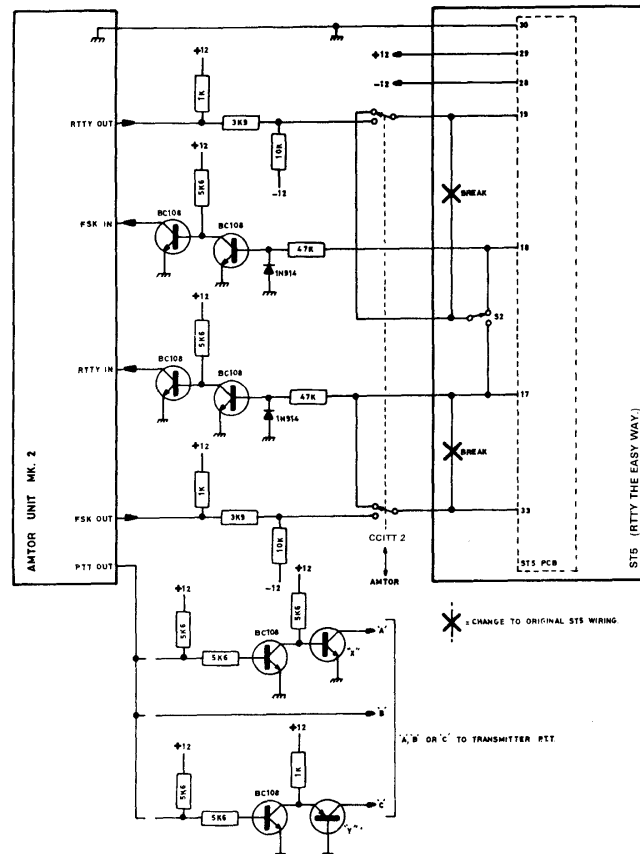

Fig 21: AMTOR Mk2 to ST5 Connections

Expanding the ST5

The basic ST5 Terminal Unit is an excellent design, but nevertheless it is a design which can be expanded, both to improve the copy and to make operation easier.

The BARTG Control Board which can be added to the basic ST5 fulfils these aims, and contains the following elements:

ACTIVE LOW PASS FILTER (ALPF)

This filter Limits the post-detector bandwidth to the minimum required for good copy, and is optimised for 45/50 baud operation.

AUTOMATIC THRESHOLD CORRECTOR (ATC)

If the tuning of the receiver drifts from the correct point, the output from the Low pass filter will be asymmetrical with respect to ground. Unless further action is taken, this would give rise to severe telegraphic distortion. The purpose of the ATC is to centre the signal with respect to ground, and so provide the optimum signal for the dicer stage on the main ST5 board.

AUTOPRINT

One Limitation of the basic Terminal Unit is its inability automatically to hold the printer in the Mark condition when there is no RTTY signal present, and hence to stop the machine "chattering" due to noise from the receiver. The Autoprint feature prevents this happening, and its operation relies on the fact that an RTTY signal has a 100% duty cycle (i.e. either a Mark or a Space is always present) - this compares to 30% or Less for SSB and CW signals. Note however that this circuit is incapable of distinguishing between an RTTY signal and a steady, unmodulated carrier, as both have a 100% duty cycle.

MOTOR CONTROL

When the Autoprint circuit recognises an incoming signal as RTTY, in addition to enabling the printer electromagnet, the printer motor is automatically turned on. When the Autoprint circuit turns off with the cessation of the incoming RTTY signal, the printer motor is held on for approximately 30 seconds, before being switched off automatically.

The full circuit of the Control Board is shown in Fig 22. The interconnections between the Control Board, the ST5 board, the printer motor and the FSK/AFSK board are shown in Fig 24. Also, Figs 23 and 25 show the two sides of the Control Board PCB.

CONTROL SWITCHES

There are four control switches, S1 to S4. These have the following functions:

S1 - NORMAL/REVERSE

See Fig 22. This switch has the same function as in the ST5, but is now connected to the Control Board instead of to the main ST5 board.

S2 - RX/TX

See Fig 24. The existing wiring to this switch is not affected by the addition of the Control Board. However, a second pole of this switch is required to maintain the motor in the ON condition during transmission. A third pole on the switch may be included to operate the transmitter PTT, giving one-switch control to the station.

S3 - AUTOPRINT ON/OFF

See Fig 24. This is a new switch, which allows the operator to choose between operation under the control of the Autoprint circuit, or under manual control for copying weak noisy signals. With the Autoprint switched off, the printer motor is maintained ON.

S4 - MANUAL MOTOR ON/OFF

See Fig 24. This is also a new switch, allowing the printer motor to be switched on at any time, without affecting the operation of the Autoprint circuit.

CONSTRUCTION

Current issues of the BARTG ST5 printed circuit board have all the necessary fixing holes to mount the Control Board. If the ST5 board does not have these holes, the following steps need to be carried out before fitting any of the components to the Control Board.

The bare Control Board is used as a drilling jig, and should be temporarily mounted underneath the ST5 board utilising the fixing holes adjacent to terminals 12 and 25 (see Fig 11). The position of the third fixing hole may now be marked through the Control Board onto the ST5 board (in the area between R30, R31, VR2 and C16 on the STS board). Use a drill 1/8" (3mm) diameter.

CONTROL BOARD ASSEMBLY

Insert all the components, together with the terminal pins.

The value of R36 should be chosen to suit the motor control relay to be used. The maximum ratings for this relay are 17V and 100mA. For example, for a 12V relay having a coil resistance of 185 ohms, the value of R36 is calculated by Ohm's Law as follows:

$$R36 = \frac{17 - 12}{12} \times 185 = 77 \text{ ohms}$$

If the calculated value is not a standard resistor value (as in this example), the nearest standard value should be chosen (in this case 82 ohms at 1 watt).

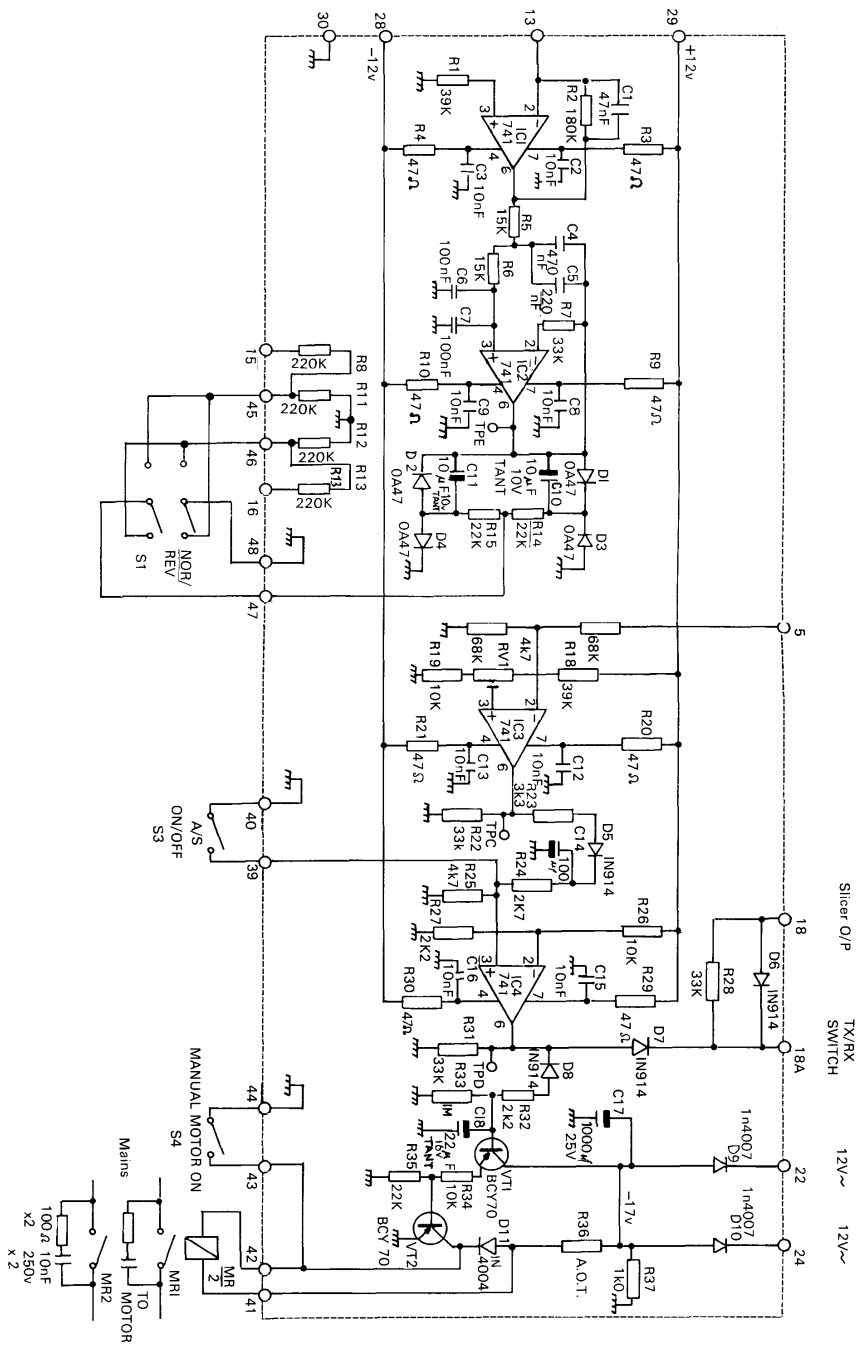

Fig 22 Control Board Schematic

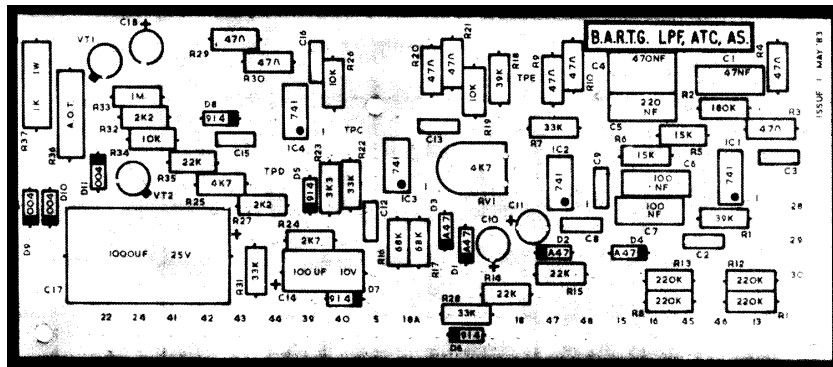

Fig 23: Control Printed Circuit Board Component Layout

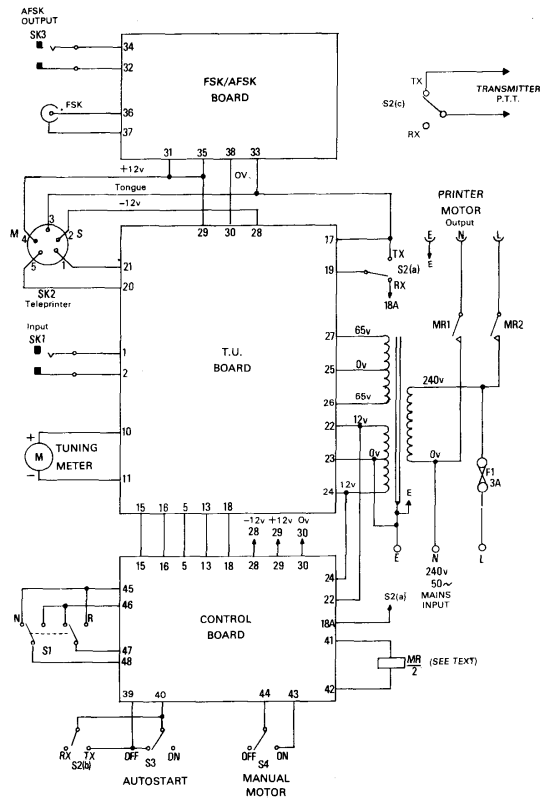

Fig 24: Expanded ST5 Inter Unit Wiring

ST5 BOARD MODIFICATIONS

Remove the following components from the ST5 board:

- R14 (150K), R16 (100K), R18 (100K) C4 (22nF), C10 (22nF), C11 (68nF)

FINAL ASSEMBLY

Using suitable nuts, bolts and 1" spacing pillars, mount the Control Board adjacent to the FSK/AFSK board, above the ST5 board. Then modify the existing external wiring to conform to Fig 24. Note that terminal 14 on the ST5 board is no longer used.

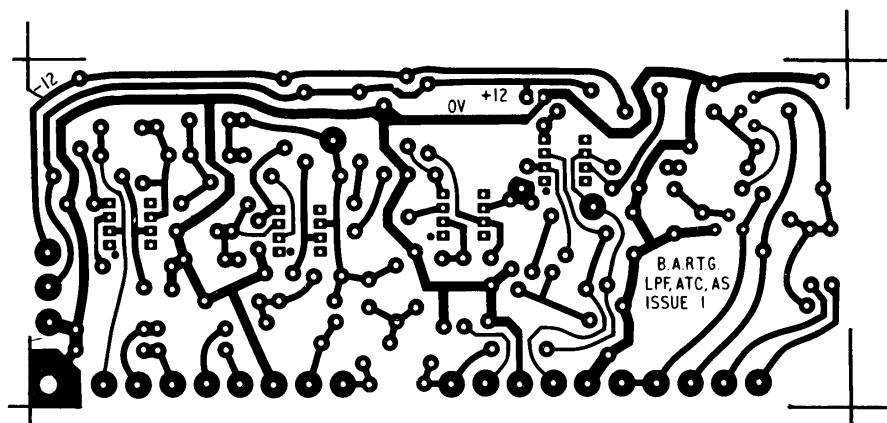

Fig 25: Control Board Printed Circuit Track Layout

ALIGNMENT

A DC voltmeter and AF generator are required for alignment. See Fig 22. (a) Connect the DC voltmeter between test point TPC and ground (terminal 30) on the Control Board. (b) Connect the AF generator to the input of the ST5 (SK1 - see Fig 24), and adjust the frequency to obtain a reading of 60% on the tuning meter (assuming a peak reading of 70% as described in the alignment instructions for the ST5). (c) Adjust RV1 on the Control Board to a position where the voltage at TPC just switches between positive and negative. The setting of RV1 will depend on how accurately the TU discriminator is tuned, and on other external factors such as whether a pre-Limiter band pass filter is in use, but is not over critical.

OPERATING

Once the Control Board has been installed, using the ST5 is even easier than before. The normal method of operating is to leave the Autoprint switched on whilst tuning around the band, to stop the printer "chattering" on noise from the receiver. As soon as an RTTY signal is tuned in, there will be a delay of approximately one

second, after which the printer motor will turn on, and the machine will start to print (assuming the signal is not at the wrong speed, upside down or in the wrong code).

When the transmitting station cuts carrier, the machine will print two or three random characters due to noise, after which the printer will be held in the Mark condition. The printer motor will continue to run, and if no further signals are received it will automatically turn off after approximately 30 seconds. With the inclusion of the input band pass filter, the active low pass filter and the automatic threshold corrector, the TU is quite capable of copying signals which are only a little above the noise level. Under these conditions the poor quality of the signal will not allow the Autoprint to operate, but switching the Autoprint off will put the motor on and will allow the printer to copy what signal there is.

If the printer has a built-in motor timer, it may be found more convenient to operate with the normal motor switch permanently on, or with the printer motor timer disabled. However, this is best found out by trial and error.

CONTROL BOARD COMPONENTS LIST

Resistors (all 1/4 watt except where otherwise stated)

R3,4,9,10,20,21, 29,30	47	R14,15,35	22K
R37	1K (1 watt)	R7,22,28,31	33K
R27,32	2K2	R1,18	39K
R24	2K7	R16,17	68K
R23	3K3	R2	180K
R25	4K7	R8,11,12,13	220K
R19,26,24	10K	R33	1M
R5,6	15K	R36	see text
		RV1	4K7 skeleton preset

Capacitors

C2,3,8,9,12,13,15,1 6	10nF	25V disc ceramic
C1	47nF	5% polycarbonate
C6,7	100nF	5% polycarbonate
C5	220nF	5% polycarbonate
C4	470nF	5% polycarbonate

C10,11	10uF	16V tantalum bead
C18	22uF	16V tantalum bead
C14	100uF	10V electrolytic
C17	1000uF	25V electrolytic

Semiconductors

IC1,2,3,4	741 operational amp
VT1,2	BCY70 transistor - pnp
D1,2,3,4	OA47 diode - germanium
D5,6,7,8	1N914 diode - silicon
D9,10,11	1N4004 diode - silicon

Miscellaneous

Control Board PCB - available from BARTG. Terminal pins (0.040") 24 off

Motor relay, 2-pole, 12-17V coil

Contact suppression components for the motor relay: 100 ohm 1 watt resistor 2 off

10nF 250V AC capacitor 2 off

Computers and RTTY

So you have a microcomputer, what other items are needed to commence RTTY operations?

1. RTTY Modem

Elsewhere in this booklet the ST5 Terminal Unit (modem) is described, and our advice is very definitely that this is an excellent design to work with a computer; as the 80 volt circuitry is redundant it may be left out.

2. An RTTY Program

Our advice even to people who are competent to program a computer at the level required to get an RTTY system running is to look at adverts in DATACOM or Radcom to see if there is any commercially produced program on sale, or else approach BARTG for advice on this. There is no point in reinventing the wheel for the sake of the few pounds it takes to acquire a working program.

For those who wish to embark on a program, and for those who wish to understand what is happening in their system some advice is presented Later in this section.

Before we talk about what to Look for in an RTTY program we must consider the connection between the modem and the computer.

3. The Interface

This is a word that means different

things in different contexts; anything from another computer to a length of wire, and is used as a catch-all word to describe the Link between the modem and the computer. In the case of the ST5 and many personal computers the only interfacing required in addition to that provided in the circuit is the appropriate plug for the computer socket. In others however there is more to it.

There are two main considerations: a. Voltage conversion to the levels needed by the computer from whatever signal voltage is available on the modem. In many modems for RTTY this is 0-5 volts so there should be no problem. In standard versions of the ST5 only -10/+10 volts is available and the STS needs up to +12 volts to toggle the transmit tones.

b. Serial to parallel data conversion. As described in the following section, one of the ways of easing the burden on the programmer is to use a UART which intercepts the incoming data stream and waits until a whole character has been assembled from its individual bits before sending it to the computer. This requires in addition to the UART some method of providing timing for this process.

RTTY PROGRAM STANDARDS

Primarily, an RTTY program turns a computer into a machine which is emulating a mechanical teleprinter

and therefore the program must be able to send RTTY which can be copied by such a machine. It is of prime importance to make sure that the program at Least inserts the CR/LF end of Line sequence at the proper end of the line for a teleprinter, not later than the 69th character. A better program will allow the user to type away without regard for this and insert CR/LFs appropriately between words.

As time goes by, there is a gradual improvement in the facilities offered by programs which enable an inexperienced typist to conduct an RTTY QSO at a reasonable rate and the intending purchaser will look at how easy it is to use these.

It is now reasonable to expect a program which allows the user to type all the time so that replies are prepared during receive periods and that the store reserved for this purpose is at Least one thousand characters in size. The screen should be split between send and receive with some sort of status display, and the more status information the more useful is the program - baud rate, tuning information, receive polarity, tx/rx indicator, time of day, etc etc.

Spare memory in the computer should be used as a receive store. Transmitted text should, as a default option, also be put into this store (preferably in inverse or Lower case characters) so that review is possible. Words should not be split in incoming text. Multiple Line feeds should be suppressed. Optionally there may be shift back to Letters after a space character.

On transmit there should be a way of editing characters before they go out so that mistakes can be corrected. The program should be able to switch the rig between transmit and receive. There should be about ten pre-programmed messages which the user can alter easily. If 'PSE K' is programmed, it should switch the rig.

The precise point reached during sending of a pre-typed message should be easily visible.

PROGRAMMING FOR RTTY

A complete RTTY system consists of tone encoding/decoding, serial/ parallel conversion,

five/eight unit code conversion, keyboard and screen display handling.

It is possible to carry out all of the above functions by software inside the computer, and indeed this has been done. Whilst this approach is satisfactory for copying clean, noise-free signals, most people would prefer to use a proper modem and release computer power for other functions. At the expense of having to build more hardware, the provision of a UART transfers all the fast decoding out of the computer and a reasonably proficient programmer should find no difficulty in the code conversion, keyboard and screen handling tasks that are Left. A common approach is to use the computer connected straight to the modem and Look directly at the incoming data. The advantage of doing this is that the whole process is under your control and extra features beyond that of a normal UART can be built in, such as a tuning display and error handling.

RF Equipment

RECEIVERS

Most receivers can be put to RTTY service but for reliable results the stability should be at least as good as that of sideband equipment. A 600 ohm audio output is preferable though by no means essential. If no high impedance output is provided, simply connect the TU in parallel with the Loudspeaker.

For 170Hz FSK reception an ideal receiver would have a bandwidth of 400Hz or less but most amateurs get along quite nicely with the wider bandwidth of SSB filters. If you are not using an SSB receiver, then your receiver must have a BFO control. It is essential for FSK reception and hence a must on HF Gut even on VHF where AFSK may be in use it is strongly recommended that a BFO be available so as to copy FSK - without a BFO it is impossible to appreciate the great difference that FSK makes for weak signals.

TRANSMITTERS

The above comments with regard to stability apply to transmitters but even more so.

When using the BARTG AFSK oscillator with a sideband transmitter (mode F1B), switch the transmitter to USB. Use of USB will result in Mark being the higher radio frequency - if for any reason the shift needs to be reversed, simply

change to the opposite sideband. Feed the AFSK signal from SK3 into the microphone socket and turn the output level

down to zero by adjusting VR6. Gradually increase the signal level by adjusting VR6 and/or the microphone gain control taking care not to overdrive the transmitter PA as an RTTY signal has a 100% duty cycle - a simple rule of thumb is to Limit the PA input power to twice the rated PA dissipation. Note that this assumes that the transmitter is correctly tuned and matched to the antenna.

To improve the efficiency of the PA the bias supply could be altered so that the PA has no standing current when there is no drive. The point being that for FSK the PA does not have to be linear. PLEASE, when changing back to phone, alter the bias back to the linear region to avoid serious splatter.

If any other type of transmitter is to be employed, e.g. CW or AM, then one of the FSK circuits of Fig 8 may be used. Some of the AM/CW rigs of the pre-sideband days can do stalwart service in RTTY. Remember that in a "multiplier" type of transmitter, the shift may get multiplied; e.g. to produce 170Hz shift at 20m from a 3.5MHz VFO a basic shift of 42.5Hz will be required.

High power is not essential; many RTTY signals are the result of less than 50 watts input.

For AFSK transmission at VHF, simply feed the tones into the microphone socket of an FM, or possibly an AM, transmitter to produce F2B and A2B signals respectively.

Operating

RECEIVING

Tune around 14.090MHz and try to find an amateur transmission. These can usually be recognised by the narrow shift (a slight warble as opposed to the abrupt change in note of wider shifts) and the pauses between characters, the pauses being caused by the operator at the far end looking for the next key ("hunt and peck" technique).

While he Looks for a key the signal stays steady in the Mark state and as the key is pressed there is a short burst of "warble" followed by another period of steady Mark. Even with slick operators

there will still be pauses which probably signify that the signal is of amateur origin.

When a signal has been found, tune the receiver for maximum signal strength and adjust the BFO to obtain a steady reading on the TU tuning meter. If the incoming shift exactly matches the TU tuned circuits the meter will read the same as specified in the ST5 setting up instructions given earlier (70% of full-scale).

Once the optimum setting for the BFO has been found it should be Left well alone and all the tuning done on the receiver main dial (as receiving sideband phone); this of course will also apply when no separate BFO adjustment is provided. Switch S2 to RX and observe the behaviour of the printing mechanism - if it produces garble and "races"

between characters, throw switch S1. A good indication that S1 is in the wrong position is if a string of SYSYSYSY is printed, on throwing the switch, such a signal will change to RYRYRYRY, the standard RTTY tuning signal.

Expect a number of disappointments to begin with - it takes a Little practice.

If no amateur signals can be found, or the receiver in use does not cover any convenient amateur bands, it should be possible to find some other narrow shift transmissions elsewhere in the HF spectrum, probably with a speed of 50 Bauds, but be prepared for a lot of disappointing garble as there are many factors that can cause non-amateur signals to be incompatible with the relatively simple receiving equipment.

TRANSMITTING

If joining a QSO or replying to a CQ call, try to zero beat your Mark frequency with that of the other station (on SSB simply tune so that the receive copy is OK) and then start your transmission with half a Line of RYRYRYRY (it helps the other operator to tune you in).

Follow this with CAR-RTN LINEFEED LTRS G2QQQ DE G2ZZZ CAR-RTN LINEFEED LTRS ... and you're off! (It is also nice practice to type in the time, GMT, after the callsigns, if nothing else, it makes log keeping that much easier!) At the end of

every line of no more than 69 characters send at Least one sequence of CAR-RTN LINEFEED LTRS and in poor conditions throw in a few more for good measure.

End your over with G2QQQ DE G2ZZZ
KKKKK but don't go over with the other chap's
carriage half way along the line - remember to
finish off with a neat CAR-RTN LINEFEED
LTRS LTRS.

Don't worry about your slow typing speed -
RTTY is not a rat-race, not even in contests, and
most RTTYers are tolerant folk, but do keep the
overs short and snappy. Five minutes is long
enough in the early days and never over ten
minutes.

As with all modes, a good number of hours spent
listening/copying before "hitting the transmit
button" gives invaluable operating instruction.

Activity

Most amateur RTTY will be found on the HF
bands, especially around 14.090MHz but there is
also a strong and growing interest in VHF
printing, mainly on 144.600MHz (FSK) and
145.300MHz (AFSK) with a little activity on
70cm. Under the terms of the licence British
amateurs are allowed to transmit data, so from
time to time signals may be heard which just
print garble. (Data is similar to RTTY, but using
different codes and speeds).

On HF, amateur RTTY is transmitted as FSK in
the upper part of the CW sub-bands e.g.
3.590MHz. At VHF, two modes are in common
use: FSK (FIB - as on the HF bands) and AFSK
(F2B). The latter is suitable for local ragchews
with a range about the same as phone, while FSK
is for DX working with a range comparable with
CW.

Of all the bands, 20m is the most popular but
Sunday mornings produce a high "G" activity on
80m before and after the BARTG news bulletins
(see below). Continental countries are active
most evenings on 80m for those persons who
prefer a longer range contact. VHF printing
varies across the country so it is suggested that a
newcomer contact Local RTTY enthusiasts to
ascertain the level of activity.

Each week there are several news bulletins
transmitted - the most well established being
those of PAOAA and the ARRL Headquarters
station W1AW.

Last but by no means least, BARTG transmits its
own bulletins - details of the schedule are shown
on the back cover of DATACOM.

Throughout the year several RTTY contests are
organised. The results of the HF contests
contribute to the World-Wide RTTY
Championship. BARTG sponsors three contests:
an HF one held in the Spring, a VHF/UHF one
also held in the Spring, and a VHF/UHF event in
the Autumn. There are also many other contests
organised by the various national societies.

For more information on these contests
the BARTG magazine DATACOM is invaluable.

Glossary of Terms

AFSK

"Audio Frequency Shift Keying" - a mode of
transmission used at VHF where an FM or AM
signal is alternately modulated by one of a pair of
tones; e.g. 1445Hz for Mark and 1275Hz for
Space. Designated as F2B or A2B.

Autoprint

Technique where the printer is held at Mark until
a genuine RTTY signal is correctly tuned - may
be used as a simple form of autostart.

Autostart

Technique where a station can be left unattended,
monitoring a frequency. Genuine RTTY signals
are copied but interference, noise etc, is rejected.
Usually involves some form of motor control.

BARTG

British Amateur Radio Teleprinter Group, the
UK organisation catering specifically for all
forms of data communication, including RTTY,
AMTOR, Packet Radio and FAX.

Baud

Measure of signalling speed; e.g. a 7B teleprinter
with a motor speed of 3000 rpm runs at a baud
rate of 50 (approximately equivalent to 66 words
per minute).

CCITT 2 - 5 Unit teleprinter code The RTTY
code used internationally by amateurs and
professionals - often referred to (incorrectly) as
"Murray" or "Baudot" code.

FIFO

"First-In-First-Out" - type of buffer memory used
in some electronic keyboards and speed
convertors.

FSK

"Frequency Shift Keying" - most commonly used
mode of RTTY transmission. The RF carrier

frequency of a transmitter is shifted; e.g. Mark frequency may be 14090.170KHz and the Space frequency 14090.000KHz. Usually generated by modulating an SSB transmitter with two audio tones. Designated as F1B. Governor

Device fitted to many machines to control the speed of the motor. Usually carries black and white stroboscopic markings around its circumference.

Mark

The normal steady state condition of a printer or keyboard when no signals are being received or no key has been pressed - easily remembered as "marking time".

Modem

This is a contraction of "MODulator/ DEModulator". Also an alternative description of a Terminal Unit. Neutral

Type of signalling system - the two states e.g. Mark and Space, are defined by the presence or absence of a current in a circuit; i.e. on/off keying.

Polar

Alternative to neutral - the Mark and Space conditions are defined by current flowing in opposite directions. Most Creed machines are designed for polar operation but some can be modified for neutral operation.

Polarised Relay

A widely used device for locally regenerating weak DC signals.

RTTY

"Radio Teleprinter TelegraphY" or "Radio TeleTYpe" (Note that "TELETYPE" is a registered trademark of the Teletype Corporation).

Selector magnet

The interfacing component on the receive side of a teleprinter. It converts the electrical impulses of the signalling circuit (TU) into mechanical displacements.

Space

The alternative state to Mark. Teleprinter characters consist of a series of Marks and Spaces - the two states are similar in nature to the "key up" and "key down" states of a Morse transmission.

Terminal Unit (TU)

Device for converting received signals into pulses suitable for driving a teleprinter and/or a computer - also known as frequency shift converter. Performs the reverse function on transmit; i.e. it accepts teleprinter keyboard and/or computer level voltages and converts these into standard RTTY tones. Also sometimes referred to as a modem.

UART

"Universal Asynchronous Receiver and Transmitter" - a type of integrated circuit which converts serial start/ stop signals, such as RTTY characters, into parallel signals. Similarly, it converts parallel data into serial RTTY characters.

VDU

"Visual Display Unit" - device for displaying text messages on a television or monitor screen.