

*Crown Copyright Reserved*

P.W.—D. 4

## Post Office Engineering Department

---

# TECHNICAL PAMPHLETS FOR WORKMEN

---

*Subject*  
**Magneto Exchanges—  
Non-Multiple Type**

*ENGINEER-IN-CHIEF'S OFFICE*

*June, 1934*

*(Reprinted January, 1935)*

LONDON

PRINTED AND PUBLISHED BY HIS MAJESTY'S STATIONERY OFFICE  
To be purchased directly from H.M. STATIONERY OFFICE at the following  
addresses :

Adastral House, Kingsway, London, W.C.2; 120 George Street, Edinburgh 2  
York Street, Manchester 1; 1 St. Andrew's Crescent, Cardiff;  
80 Chichester Street, Belfast;  
or through any Bookseller

1935

Price 6*d.* Net

43-9999

===== LIST OF =====

# Technical Pamphlets for Workmen

---

## GROUP A.

1. Magnetism and Electricity.
2. Primary Batteries.
3. Technical Terms.
4. Test Boards.
5. Protective Fittings.
6. Measuring and Testing Instruments.
7. Sensitivity of Apparatus.
8. Standard List of Terms and Definitions used in Telegraphy and Telephony. (*Not on sale.*)
9. Standard Graphical Symbols for Telegraphy, Telephony and Radio Communication. (*Not on sale.*)

## GROUP B.

1. Elementary Principles of Telegraphy and Systems up to Morse Duplex.
2. Telegraph Concentrators.
3. Wheatstone System. Morse Keyboard Perforators.
4. Quadruplex, Quadruplex Repeated Circuits and Telegraph Repeaters, Simplex and Duplex.
5. Hughes Type-printing Telegraph.
6. Baudot Multiplex Type-printing System.
7. Western Electric Duplex Multiplex. Murray Duplex Multiplex. Siemens and Halske Automatic Type-printing System.
8. Fire Alarm Systems.

## GROUP C.

1. Wireless Transmission and Reception.
2. Interference with Reception of Broadcasting.

## GROUP D.

1. Elementary Principles of Telephony.
2. Telephone Transmission. "Loading." Telephone Repeaters and Thermionic Valves.
3. Principles of Telephone Exchange Signalling.
4. Magneto Exchanges—Non-Multiple Type.
5. Magneto Exchanges—Multiple Type.
6. C.B.S. No. 1. Exchanges—Non-Multiple Type.
7. C.B.S. Exchanges—Multiple Type.
8. C.B. Exchanges—No. 9 Type.
9. C.B. Exchanges—No. 10 Type.
10. C.B. Exchanges—No. 12 Type.
11. C.B. Exchanges—22 Volts.
12. C.B. Exchanges—40 Volts.
13. Trunk Telephone Exchanges.
14. Maintenance of Manual Telephone Exchanges.
15. Telephone Testing Equipment.
16. Routine Testing for Manual Telephone Exchanges.
17. Internal Cabling and Wiring.
18. Distribution Cases, M.D.F. and I.D.F.
19. Cord Repairs.

*[Continued on page iii of Cover.]*

# Post Office Engineering Department

---

P.W.—D.4.

---

## MAGNETO EXCHANGES— NON-MULTIPLE TYPE.

---

---

*The following pamphlets in this series are of  
kindred interest:—*

- D. 1. Elementary Principles of Telephony.
- D. 2. Telephone Transmission. "Loading." Telephone Repeater and Thermionic Valves.
- D. 3. Principles of Telephone Exchange Signalling.
- D. 5. Magneto Exchanges—Multiple Type.
- D.14. Maintenance of Manual Telephone Exchanges.
- D.15. Telephone Testing Equipment.
- D.16. Routine Testing for Manual Telephone Exchanges.
- D.17. Internal Cabling and Wiring.
- D.18. Distribution Cases, M.D.F. & I.D.F.
- D.19. Cord Repairs.
- D.21. Call Offices.
- F. 3. Subscribers' Apparatus. Magneto.
- F. 6. Private Branch Exchanges—Magneto.
- G. 2. Power Plant for Telegraph and Telephone Purposes.
- G. 3. Maintenance of Power Plant for Telegraph and Telephone Purposes.

## CORRECTION SLIP TABLE.

Serial No. of Slip.	Date of Issue.	Corrections carried in	
		on (date)	by (initials)

# MAGNETO EXCHANGES— NON-MULTIPLE TYPE.

---



---

## TABLE OF CONTENTS.

	PAGE.
INTRODUCTORY NOTES ... ..	5
APPARATUS ... ..	6
<b>CIRCUIT ARRANGEMENTS:—</b>	
SUBSCRIBER'S CIRCUIT ... ..	28
CORD CIRCUIT ... ..	30
JUNCTION WORKING ... ..	39
<b>DESCRIPTION OF SWITCHBOARDS:—</b>	
50 LINE BOARD ... ..	46
100 LINE BOARD ... ..	50
PARTY LINES ... ..	50
METHOD OF INSTALLATION ... ..	60



# MAGNETO EXCHANGES—NON-MULTIPLE TYPE.

## INTRODUCTORY NOTES.

The Magneto Telephone Exchange system derives its title from the fact that the method of calling the exchange, calling the subscriber, and providing for the severance of the connection after two subscribers have been in communication, depends upon the use of a magneto electric machine commonly known as a generator. The latter item forms part of every subscriber's instrument having a direct line to the exchange, and a generator is also included in the exchange equipment. An exception is made at the out stations in the case of party line circuits, and this will be dealt with later.

A detailed description of the smaller types of magneto switchboards is given in pamphlet F.6, dealing with Private Branch Exchanges—Magneto, and as these small boards have also been extensively used for minor magneto public exchanges, it is intended in this pamphlet to deal exclusively with the 50 and 100 line standard boards, as they form an intermediate class between the smaller boards and larger ones of over 300 lines where a multiple system is necessary.

The standard board provides the following facilities:—

(a) **Indicators** to enable the subscribers connected to the exchange to gain the attention of the operator, and to obtain the severance of a connection on the conclusion of a conversation.

(b) **Jacks and plugs and cords** for readily connecting two subscribers together.

(c) **Keys** for ringing subscribers and supervising calls.

(d) **Distinctive markings** to enable the operator to tell exactly the class of service to which each subscriber is entitled.

(e) **Junction Apparatus** for connecting subscribers to the main trunk system of the country.

The switchboard consists of a combination of various electrical and mechanical parts which are so arranged that they provide all the facilities mentioned. These various parts will now be described in detail.

## APPARATUS USED IN CONNECTION WITH MAGNETO SWITCHBOARDS.

**Indicator, Single Coil.**—Figs. 1, 2, 3A and 3B illustrate the drop indicator used on magneto boards. It consists of a soft iron core on which is wound a coil of fine wire. The coil *A* is enclosed in a soft iron tube *B* and mounted on the back of the front plate *C*. The armature *D* is a round iron disc, pivoted at the top *E*, to which is attached a long light lever *F* passing through a hole in the front plate and provided with a hook on its forward end, adapted normally to engage the upper portion of a pivoted drop shutter *G*, and to hold it in its raised position. The ends of the coils are brought out through holes in the armature by means of stout wires furnished with tags to which the external connection wires are soldered. The passage of a current through the coil attracts the armature and causes the front end of the lever to rise, thus releasing the shutter which falls to a horizontal position. Behind the shutter is painted the subscriber's number, which is visible when the shutter drops.

The indicator is designed so that the coil lies in practically a closed magnetic circuit. Lines of force generated by the passage of a current through the coil follow the path of the core of the magnet, the soft iron tube and the armature. The armature is adjusted to lie close to the core but, when attracted, is prevented from touching it by means of the non-magnetic adjustable screw *H*. The iron tube prevents the lines of force from affecting adjacent indicators when several are mounted on one strip. This is a very necessary provision in view of the limited space available in a modern switchboard, as the slightest interaction between contiguous circuits leads to very serious interferences with telephonic speech. The impedance, (*i.e.*, the total effective resistance which opposes the setting up of a variable current in the circuit) due to the great number of turns on the coil and to the closed magnetic circuit which surrounds it, is considerable; consequently, where the coil is required for ring off purposes, it must be placed in bridge across the line. In this position it causes practically no decrease in the strength of the transmitted speech. The ohmic resistance of the coil is  $1,000\Omega$ , but when required for calling purposes only the resistance is reduced to  $100\Omega$ .

The resistance of the type used for junction purposes is also  $1,000\Omega$ , but a tap is taken out at the centre point of the winding. The indicator is usually designated  $500 + 500\Omega$ . Three stout leading out wires each furnished with tubes are provided to which the external connections are made. Fig. 3A shows an end view of the indicator armature and the connection tubes. In other respects Figs. 1 and 2 apply.



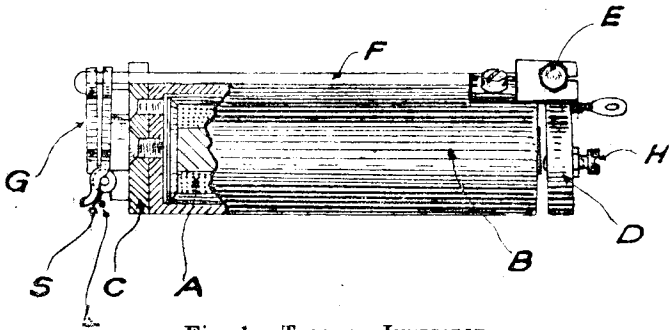

Fig. 1.—TUBULAR INDICATOR.

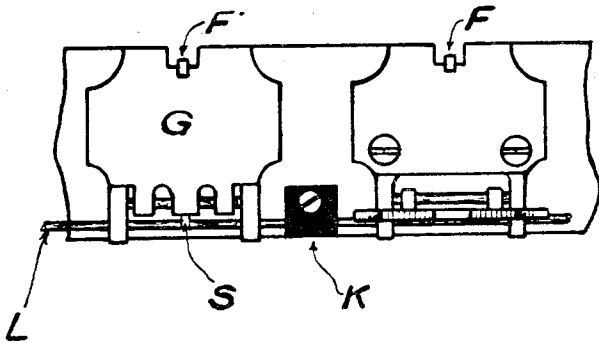

Fig. 2.—FRONT ELEVATION OF TWO SHUTTERS.  
Left shutter in normal position; right shutter in calling position.

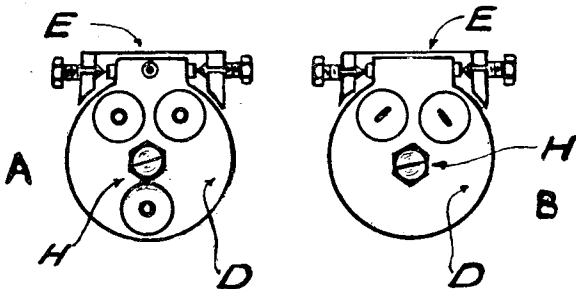

Fig. 3A.—END VIEW OF TUBULAR INDICATOR 500 + 500 OHMS.  
Fig. 3B.—END VIEW OF TUBULAR INDICATOR 1000 OHMS.

An Indicator, Double Coil, is illustrated in Figs. 4 and 5. This form of indicator consists of two coils  $M$  which are connected to the iron frame  $F$  which forms the yoke of the electromagnet. The coils are wound to a resistance of  $100\Omega$ . A soft iron armature  $A$  is pivoted at  $P$  and lies close to the soft iron cores  $K$ .

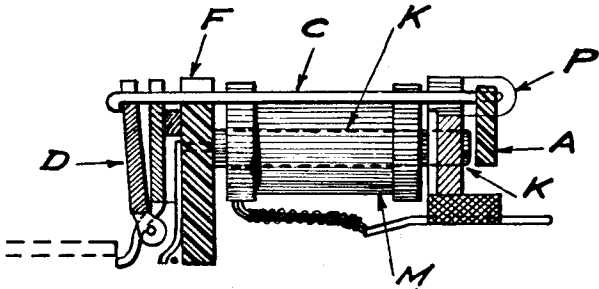

Fig. 4.—DOUBLE COIL INDICATOR, SECTIONAL ELEVATION X—Y.

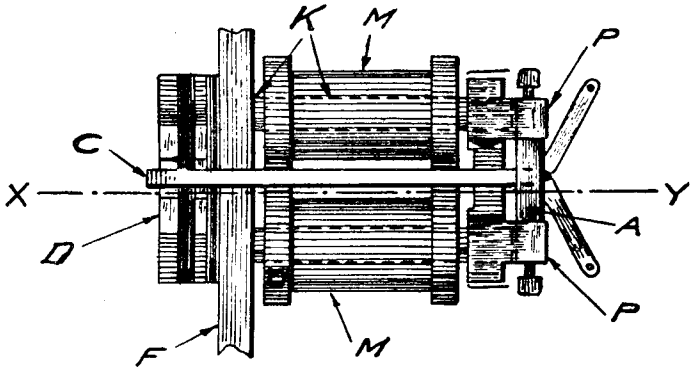

Fig. 5.—PLAN OF DOUBLE COIL INDICATOR.

A brass rod  $C$  is attached to the armature and its forward end normally holds up the shutter  $D$ .

The action is similar to that of the single coil type already described. As the coils are not iron sheathed and the resistance is comparatively low, this indicator is used only for calling purposes and is cut out when the circuit is engaged. Figs. 4 and 5 show a side elevation and plan, whilst Fig. 2 gives a front view.

**Night Bell Alarm.**—In order to attract attention when the operator is not in continuous attendance at the switchboard, each indicator is provided with additional contacts so that a local circuit, containing a battery and trembler bell, is closed when the indicator shutter falls. One contact comprises a bare copper wire *L* (Figs. 1 and 2) fixed underneath the drops and kept in position by ebonite blocks *K*. The second contact consists of a german silver spring *S* attached to the front fixed plate of the indicator. Fig. 4 shows a similar arrangement. When the shutter drops *S* (Fig. 2) is forced into contact with *L*, thus completing the bell circuit. A switch is provided to cut off the alarm circuit during busy periods. The connections are shown in Figs. 32 and 32A.

**Jacks.**—The type used for line purposes on 50 and 100 line boards is the 7-point break jack. Fig. 6 shows three of the jacks forming part of a strip of 10 jacks, and Fig. 7 gives the theoretical connections. The german silver springs 1 to 5 are fixed in slots in a strip of ebonite, springs 2 and 3 are bedded in the lower, and springs 1, 4 and 5 in the upper part of the strip. An insulated metal screw holds the upper springs firmly in position and also secures the ebonite strip to the rear of the brass base. The front part of the jack consists of a brass collar 6 which is passed through an ebonite strip, the latter being screwed to the front of the brass frame. 1 and 4 are the line springs and normally make contact with springs 2 and 3, which are kept apart at their front end by means of a small circular ebonite washer. Spring 5 makes contact with the brass collar 6. 7 is a small tongue cut out of the brass frame and turned up so as to form an additional point. When a plug is inserted in the jack, 1 and 4 break contact with 2 and 3 and are re-connected to the tip and sleeve of the plug. 5 also breaks contact with 6 and makes with 7. Points 5, 6 and 7 are not in general use on the non-multiple board. The back ebonite strip is  $10\frac{1}{8}$ " long, 1" wide and  $\frac{1}{4}$ " deep. The front ebonite strip is  $11\frac{1}{2}$ " long,  $\frac{1}{2}$ " wide and  $\frac{1}{2}$ " deep. The brass sockets are bored out to accommodate plugs of 250 mils ( $\frac{1}{4}$ " diameter). The base is provided with brass strips 8 at each end to which wires for the frame connection are soldered. The springs are provided at the back with oblong holes through which wires can be passed and soldered. Great care is needed in making these soldered connections owing to the limited space between the springs. The jacks are spaced at 1" centres. Holes are

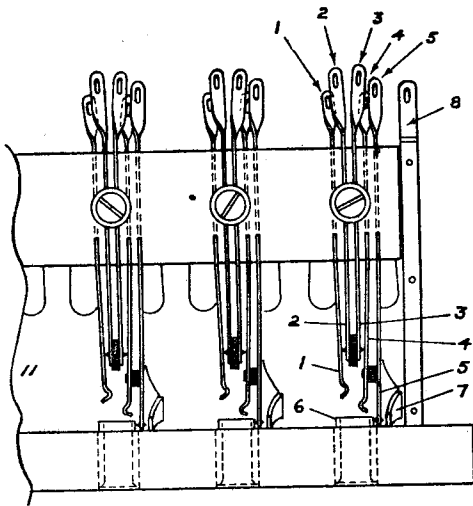

VIEW FROM UNDERSIDE

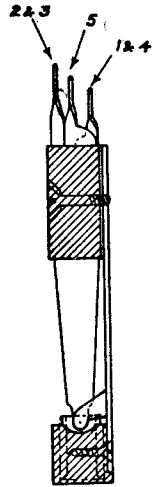

SECTION

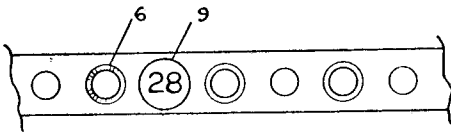

FRONT VIEW

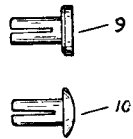

Fig. 6.—PART OF STRIP OF 7-POINT BREAK JACKS. SIDE VIEWS OF NUMBER AND PLUGGING-UP PEGS.

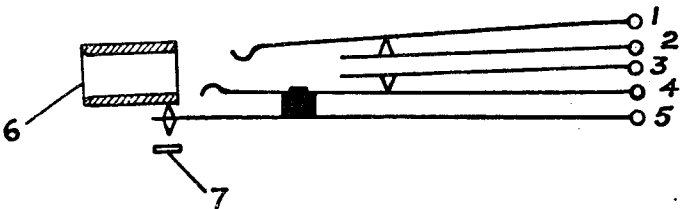

Fig. 7.—SKELETON CONNECTIONS OF 7-POINT BREAK JACK.

bored in the front ebonite strip on the right of each jack in which small pegs 9 of various colours are inserted to show the class of service. These pegs are engraved with the subscriber's number. Small ebonite pegs 10 are also provided for

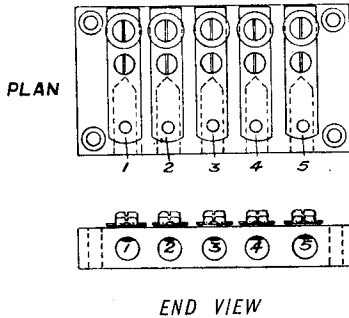

Fig. 8.—OPERATOR'S INSTRUMENT JACK.

plugging up jacks which are not in actual use. The whole strip of jacks is covered by a metal dust cover 11.

**Instrument Jack.**—The jack for connecting up the operator's telephone is illustrated in Fig. 8 (which gives a plan and end

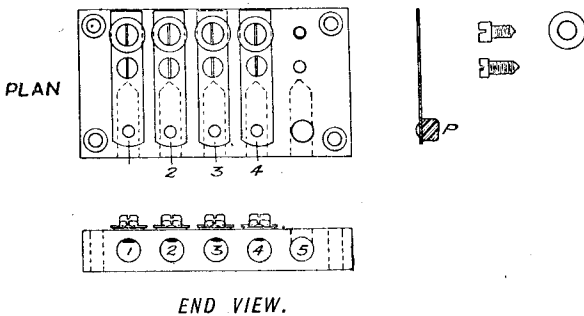

Fig. 9.—OPERATOR'S INSTRUMENT JACK WITH ONE SPRING AND SCREWS REMOVED.

view) and consists of an ebonite block bored with five holes to accommodate the 5-point operator's plug. On the upper side of these holes is a similar set of holes over which are laid five flat german silver springs of the shape shown in Fig. 9, which shows the jack with one spring and the screws removed, the

front projection *P* being of sufficient length to engage with the pin of the plug when it is inserted in the jack. Each spring is held in position by means of two screws, the one at the rear being provided with a washer and also forming the terminal for the connecting wire. Springs 1 and 5 connect up the transmitter circuit, whilst 2, 3 and 4 are used for the receiver circuit. It is, therefore, not possible to mix the connections by reversing the operator's plug in the jack.

**Operator's Plug.**—Fig. 10 shows the shape of the plug. *A* is the ebonite base in which the 5 brass pins *B* are fixed. Screws *C*, provided with metal washers, are screwed into the pins and make metallic contact with them. The screws also form the terminals to which the conductors of the flexible transmitter

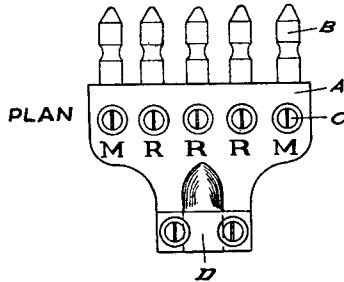

Fig. 10.—OPERATOR'S 5-POINT PLUG.

and receiver cord are connected. *M* and *R* are the transmitter and receiver terminals respectively. The back of the plug is grooved, and over this is a small ebonite bridge *D* fixed to the body of the plug by means of two screws. Over one end of the flexible cord is fitted a 6" length of leather tube and the cord and tube are then passed through the hole formed by the bridge and gripped firmly in position. This takes any strain to which the cord may be subjected and also lessens the risk of the conductors becoming detached from the terminal screws.

Care should be taken to see that the leather tube is fitted in all cases.

**Switchboard Plugs.**—These are 2-way. Fig. 11 shows the plug with the cover removed. *A* is a circular brass tube which forms the sleeve of the plug. Inside this tube is an ebonite tube *B* which insulates the body from the tip. The latter, made up of brass and steel, forms the core as shown at *C*. Connections are made to the plug by means of screws *d1* and

*d*<sub>2</sub>, the former connecting up the sleeve and the later the tip of the plug. The cover *D* of red fibre is slipped on from the tip of the plug and held in position by means of the screwed collar *E*. A small pin *F* is fitted to the sleeve of the plug,

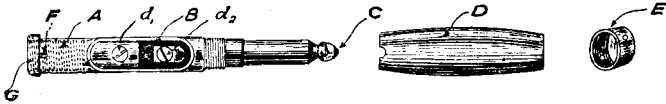

Fig. 11.—2-WAY SWITCHBOARD PLUG WITH COVER REMOVED.

which prevents the fibre cover from revolving during use. The end *G* is threaded inside in order that the thickened end of the cord may be firmly screwed into the plug before the tags of the conductors are connected to the terminal screws.

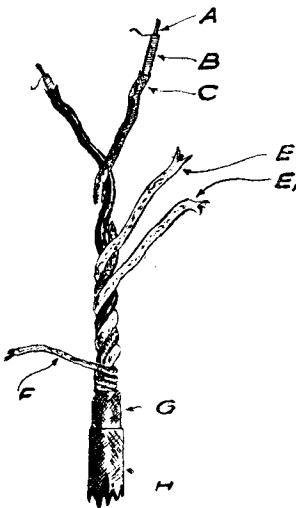

Fig 12.—SHOWING DETAILS ON 2-CONDUCTOR SWITCHBOARD CORD.

**Switchboard Cords.**—Fig. 12 shows the make up of the 2-conductor flexible cords used in connection with the switchboard plugs. *A* is a stranded copper tinsel conductor, over which are placed two layers of floss silk *B*. Above this is placed a soft white cotton braided covering *C*. The second conductor is similarly assembled except that the braided cover is blue. Each conductor has a breaking stress of approximately 35 lbs., and is 0.24Ω resistance per yard at 60° F. The conductors so formed are twisted together and wormed with two layers of soft white cotton *E* and *E*<sub>1</sub>, to provide a circular cross section. *F* is a lapping of grey cotton in the form of an open spiral. Over this is one layer (or sometimes two) of braided glacé cotton *G* and *H*, the latter

being either red or black. The completed cord is 6 ft. long.

The method of terminating is shown in Figs. 13 and 14. In Fig. 13, which shows the arrangement for connecting to the cord fastener (Fig. 15), 1 is a lapping of waxed thread, which also holds the extension braid 2. 3 is a metal stamping and serves as a support for the cord when in use. 4 is a german silver stamping in which the bared conductor is turned back and clamped. The tag of 4 connects to the cord fastener. The second conductor is similarly assembled. Fig. 14 illustrates the arrangement at the plug end. 6 is a lapping of waxed

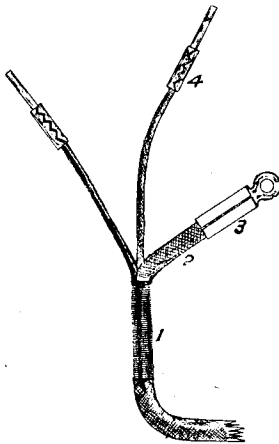

Fig. 13.—SWITCHBOARD  
CORD SHOWING ARRANGE-  
MENT FOR CONNECTING  
TO CORD FASTENER.

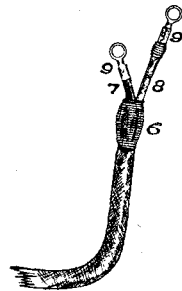

Fig. 14.—SWITCHBOARD  
CORD SHOWING METHOD  
OF TERMINATING AT  
SWITCHBOARD PLUG END.

thread thickened so that the cord may be fixed firmly in the body of the plug, 7 and 8 are the inner braided conductors (blue and white) furnished with metal stampings 9, the latter forming the connections to the tip and sleeve of the plug respectively.

The life of the cord depends greatly upon the manner in which it is used, the most frequent source of trouble being near the base of the plug. The tinsel strands are liable to become fractured and cause partial disconnection or short-circuits. On no account must the plug be pushed into the



jack or withdrawn by means of the cord, as this increases the number of faults, decreases the life of the cord and causes noisy and intermittent talks.

**Cord Fasteners and Pulley Weights.**—Fig. 15 shows the cord fastener. The long brass screw *A* is provided with clamping screws *B* and *C* by which it is fixed to the shelf *D* at the back of the switchboard. When the tag of the connecting cord is fixed in the central hole *E*, the spiral spring *F* forces the metal tube *G* firmly into contact with the tag and so forms the con-

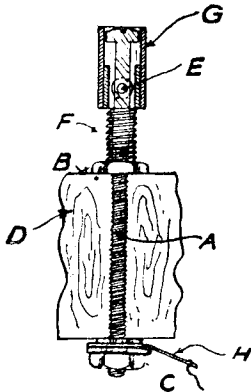

Fig. 15.—CORD FASTENER.

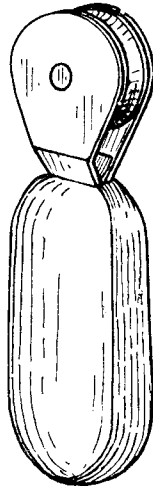

Fig. 16.—PULLEY WEIGHT.

nection between the cord and the switchboard wire which is soldered to the metal stamping *H*.

Fig. 16 shows the form of pulley weight used. It consists of a weight composed of a hard alloy of lead cast about the lower portion of the brass stamping, in which is carried a pulley through which the cord runs. The pulley weight weighs about 9 ozs., which is sufficient to restore the cord after withdrawal from the jack. In a newer type, the lead is faced with brass to prevent it being beaten out of shape by continued use.

**Induction Coils.**—The induction coil used on a 50-line magneto board is similar in principle to those described in

pamphlet F. 3, except that the secondary winding is made up of 7 mils silk covered copper wire wound to a resistance of  $150\Omega$ . Fig. 17 gives the general appearance of the coil and Fig. 18 indicates how the connections are arranged. Brass screws connect the coils to the connection places  $C_1$ ,  $C_2$ , etc. (Fig. 18), and also fix the coil. The plates are screwed to

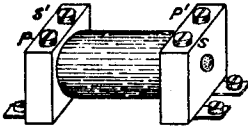

Fig. 17.—STANDARD INDUCTION COIL.

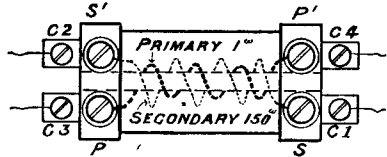

Fig. 18.—CONNECTIONS OF STANDARD INDUCTION COIL.

the woodwork and are each provided with a terminal to which the external wires are connected. In Fig. 18 it will be noticed that the coil ends of each winding are taken to the diagonal corners. This ensures that the primary and secondary cannot be reversed when it is desired to change the coil for any reason.

A type of operator's differential induction coil for local battery working, used on 100-line magneto switchboards is

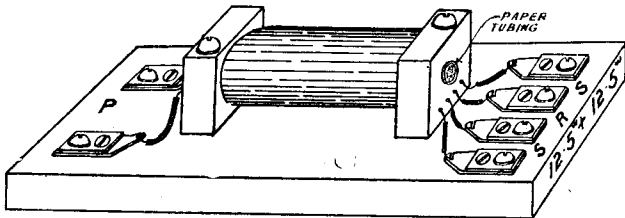
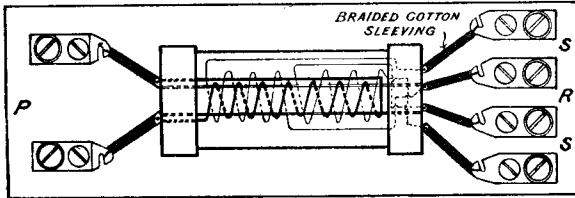

Fig. 19.—DIFFERENTIAL INDUCTION COIL.

illustrated in Fig. 19. It consists of a core of annealed soft iron wires tightly packed in a compressed paper tube and wound with a primary winding of 20 mils silk covered copper wire to a resistance of  $1\Omega$ . The secondary windings consist of two silk covered copper wires of 10 mils gauge wound together over the primary coil. Each secondary winding has a resistance of  $12.5\Omega$ . The coil cheeks are ebonised hardwood. The ends of the windings are brought out through holes in the cheeks and connected to brass terminals mounted on a wood

base to which the coil is also fixed. Fig. 20 shows a plan of the coil and details of the coil windings. Fig. 21 gives the theoretical connections. The operator's receiver *R1* (Fig. 21) is placed between the inner ends of the two secondary windings and the outer ends are joined to the inner springs of the



PLAN.

Fig. 20.—PLAN OF DIFFERENTIAL INDUCTION COIL SHOWING WINDINGS.

Ring Back key. The primary coil *P* is connected to the operator's transmitter and speaking battery.

It may be desirable and economical to provide a partial multiple in an exchange equipped with three or more 100-line boards, in which case the centre point of *R1* is connected to earth as indicated by the dotted line. This provides for an engaged test. The differential coil is installed at the outset in order to provide for this eventuality.

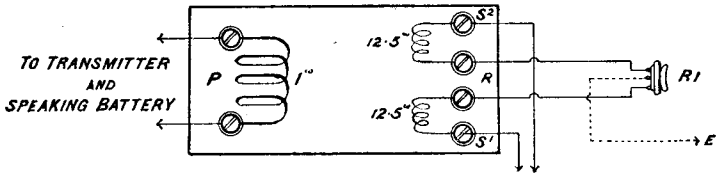

TO INNER SPRINGS OF RING BACK KEY. (See Figures 24 and 25.)

Fig. 21.—DIFFERENTIAL INDUCTION COIL, THEORETICAL CONNECTIONS.

Speaking and Ringing Key, Fig. 22. In order that an operator may be able to speak to or ring a subscriber a combined speaking and ringing key is provided for each cord circuit. It consists of a mounting plate *A* to which a metal support *B* is rigidly attached. On the lower portion of the support two sets of six insulated springs are assembled side by side and fixed with screws *C*, each provided with an ebonite insulating sleeve *D*. Springs 1, 2, 3, 7, 8, 9 form the ringing side and 4, 5, 6, 10, 11 and 12 the speaking side of the key. An ebonite roller *E*, fixed to a pivoted lever *F*, lies between the long springs 2

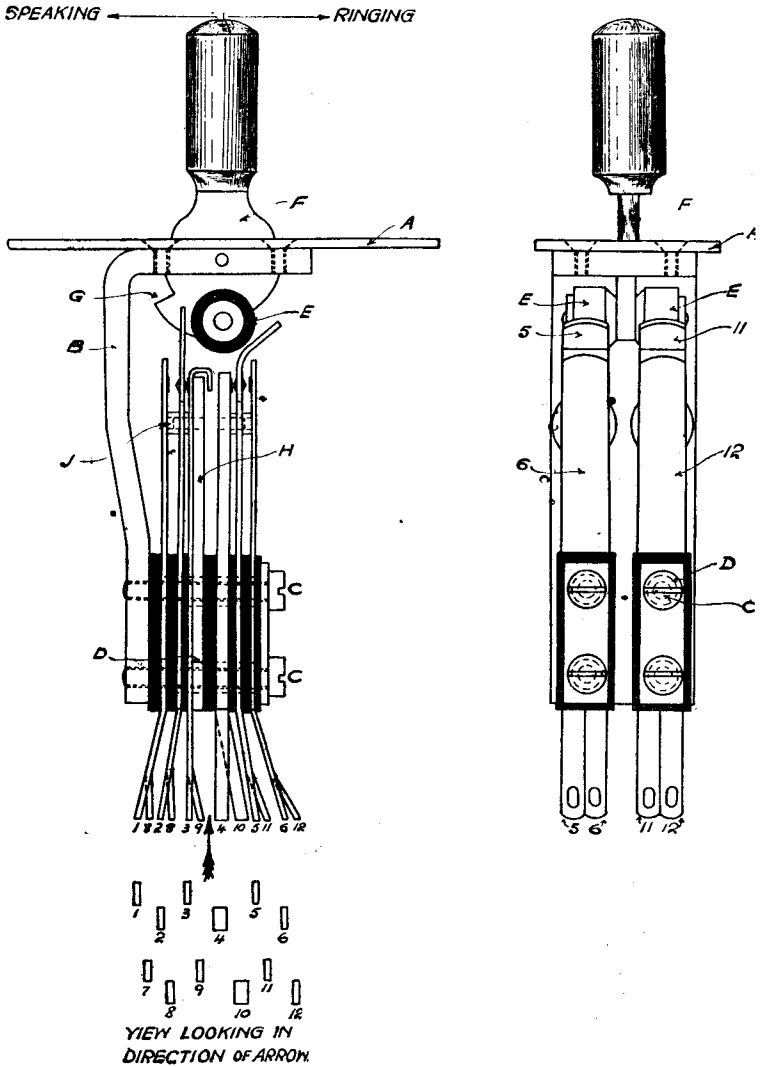

Fig. 22.—SPEAKING AND RINGING KEY.

and 8 and 5 and 11. Fig. 22 shows a side and front elevation of the key in its normal or "through" position.

It will be seen that springs 2 and 3, and 4 and 5 are in contact, as are also springs 8 and 9, and 10 and 11 of the second set. When the knob is pulled over to the ringing or "non-locking" side, roller *E* is forced to the left and spring 2 breaks from 3 and makes contact with 1; similarly spring 8 of the second set disconnects from 9 and makes with 7. The play of the roller is limited by the projection *G*. When the knob is released, long springs 2 and 8 automatically restore the key to its normal position. With the knob turned to speaking, roller *E* rides up long springs 5 and 11 and remains there. This is termed the "locking" position. Spring 5

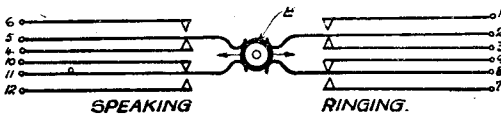

Fig. 23.—DIAGRAMMATIC VIEW OF SPEAKING AND RINGING KEY.

is forced away from 4 and reconnects with 6, whilst spring 11 of the second set leaves 10 and makes contact with 12. The key is restored by hand.

To strengthen the upper end of the springs and to prevent wrong contacts, springs 3 and 9 are provided with stiff brass backing strips *H*, to which are fixed ebonite blocks *J*. These latter pass through holes in springs 2 and 8, and bank against 1 and 7, thus providing a clear space between the outer and long springs. Spring 4 and its neighbour 10 are also thickened and provided with insulating blocks for a similar purpose.

A diagrammatic view of the key with the springs numbered to correspond is given in Fig. 23.

**Ring Back Key.**—In order that a calling subscriber may be rung when required, a single key called a **Ring Back Key** is

fitted on each switchboard. Fig. 24 gives two views in elevation and also shows the fixing plate *F*. On either side of the brass mounting *A* is a set of three hard rolled german silver springs insulated from each other with ebonite and held in position by means of two brass screws *L*<sup>1</sup> and *L*<sup>2</sup>, each bushed with an ebonite insulating tube, which passes through the springs, and is screwed into the metal block *K*. *B*<sup>1</sup> and *B*<sup>2</sup> are the inner long springs and are curved at the top as shown. *C*<sup>1</sup> and *C*<sup>2</sup> are normally in contact with *B*<sup>1</sup> and *B*<sup>2</sup>. *D*<sup>1</sup> and *D*<sup>2</sup> are the outer springs and are normally disconnected. The

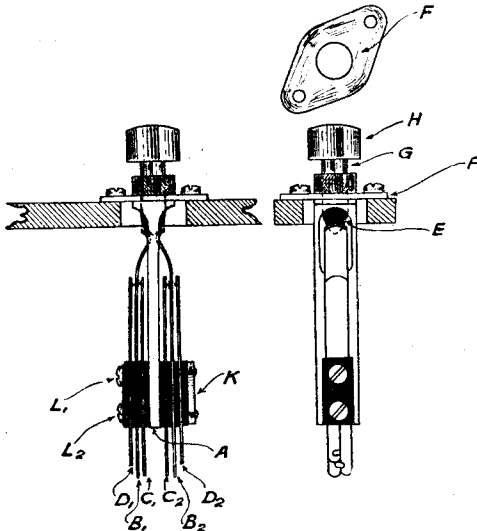

Fig. 24.—RING BACK KEY AND FIXING PLATE.

plunger consists of an ebonite piece *E* and a brass stem *G*, which is screwed at its upper end to receive the white knob *H*. *F* is an iron fixing plate to which the support *A* is attached. When the plunger is depressed, long springs *B*<sup>1</sup> and *B*<sup>2</sup> are forced away from *C*<sup>1</sup> and *C*<sup>2</sup> and make contact with *D*<sup>1</sup> and *D*<sup>2</sup>. When the plunger is released the long springs force it upwards and so establish the normal contacts.

**Magneto Generator.**—The magneto generator is similar in construction to that fitted in the magneto telephone described in pamphlet F.3. It is, however, mounted in a wooden case provided with terminals. Figs. 53 and 58 show it in position on the switchboard.

**Operators' Instruments.**—For use during slack periods a Hand Micro-Telephone, made up of a combined standard transmitter and receiver, is used. One end of the flexible cord is connected to the operator's plug shown on page 10. The hand micro-telephone is fully described in pamphlet F.3.

When continuous attention is necessary at a switchboard an operator's head-gear set, designed for attachment to the person of the operator, is provided. This leaves both hands free for operating. The receiver is of the standard watch pattern with two steel bands attached. To the other end of the bands is fitted a soft leather pad, which rests above the operator's right ear. The standard transmitter is fixed to an aluminium breastplate provided with two metal buttons and clips, to which an elastic band is fixed. Fig. 25 illustrates the instrument complete with flexible cords, and also shows by dotted lines the various internal connecting wires on the breast-plate.

The ends of the receiver coils  $40 + 40\Omega$  are brought out to terminals 2 and 4 whilst the centre point of the winding is connected to terminal 3. The steel bands are fixed to the centre stud 6 by means of the cranked arm 7. A small piece of ebonite 8 prevents contact between the bands and either coil terminal.

The receiver cord consists of three separate flexible conductors and a braided cotton lace, plaited together to form the complete cord. Each conductor consists of a central strand of copper tinsel wires, over which is a braided silk covering and an outer covering of braided cotton. The loop connections to the receiver and breastplate terminals are each strengthened by means of a lapping of very fine tinned copper wire. The cotton lace is tied to the spindle of receiver terminal 3 and helps to take any strain to which the cord is subjected.

The other end of the receiver cord terminates on a circular ebonite block A furnished with three terminals and an ebonite bridge 9, which serves to clamp the cord to the block. An insulated wire joined to the under side of each terminal forms the connection from block A to terminals 2, 3 and 4 of ebonite block B. Block B has two additional terminals, 1 and 5, from which insulated wires are run to transmitter springs 1 and 5. Spring 1 connects up one side of the transmitter and spring 5 makes contact with an insulated metal strip 10 on the periphery of the case which joins up the other side of the transmitter. The transmitter case is mounted on a metal support 11, and may be rotated at right angles to the diaphragm. This arrangement enables the operator to cut out the transmitter whilst "listening-in" on any cord circuit and during slack periods.

The 5-conductor flexible cord which connects the terminals on block B to the operator's plug (described on page 10), is

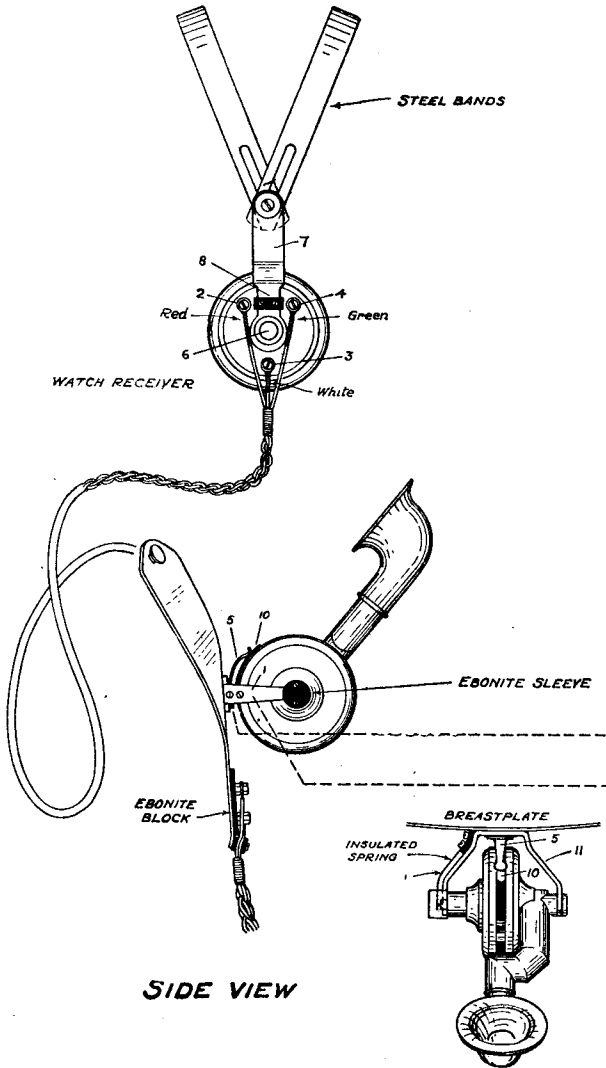

**SIDE VIEW**

**PLAN**

**Fig. 25.—OPERATOR'S**



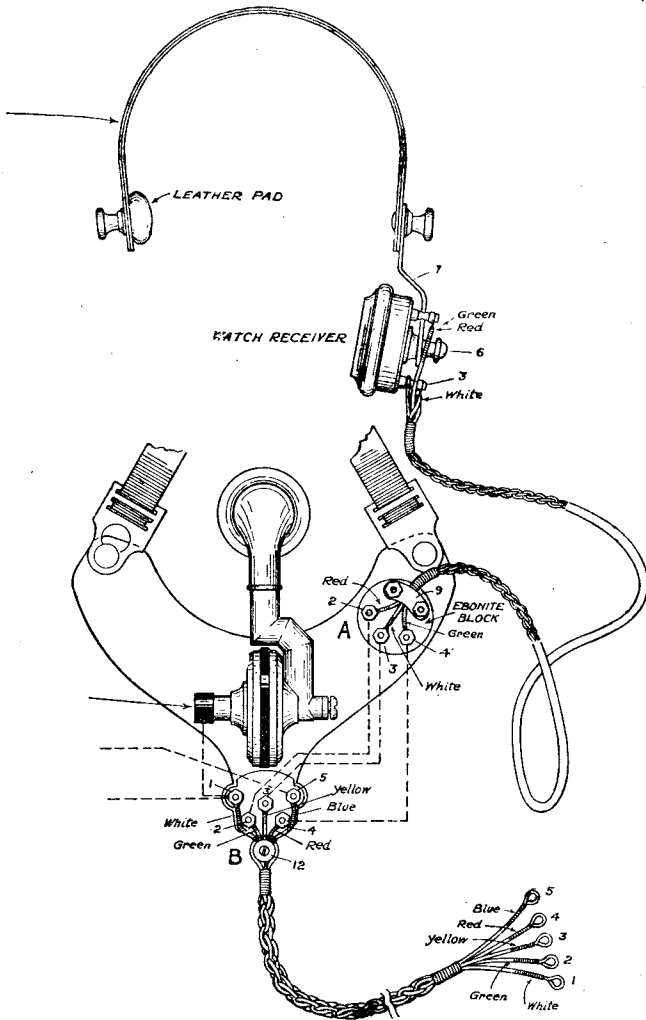

FRONT VIEW

HEAD-GEAR TELEPHONE.

made up in a similar manner to that of the receiver cord. At the breastplate end the conductors are passed round an ebonite disc 12, screwed to the plate, and tightly laced on either side. This takes any strain on the cord and prevents the conductors from being fractured at their terminal points.

To enable the connections to be readily traced similar numbers have been given throughout. Thus, conductors 2, 3 and 4 of the 5-way cord are connected to similarly numbered terminals of the receiver *via* blocks B and A, whilst conductors 1 and 5 are joined through to transmitter springs 1 and 5 *via* block B.

**Trembler Bell.**—The form of trembler bell in general use on switchboards is illustrated in Fig. 26, which shows the working

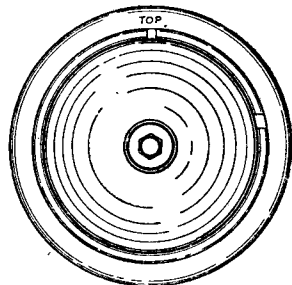
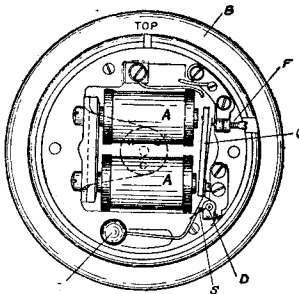

Fig. 26.—CIRCULAR TREMBLER BELL, SHOWING WORKING PARTS. Fig. 27.—PLAN OF CIRCULAR TREMBLER BELL.

parts, and Fig. 27, which gives a view with the bell dome in position. AA is an electro-magnet wound to a resistance of 100Ω and mounted on a wooden base B. The armature C, furnished with a spiral spring S, is pivoted at D and provided with an extension rod and hammer E. A small flat spring attached to the armature normally rests against the insulated adjustable contact screw F, both contacts being platinum-tipped to minimize the effects of sparking at the contact points. An extension plate (shown by dotted lines) screwed to the yoke of the electro-magnet forms the support for the bell dome which covers and protects the working parts. The upper part of the support is furnished with a screw and three small pins. The dome is provided with a central hole through which the screw passes and three smaller holes for the pins, and is clamped by means of a hexagonal nut. The pins prevent any rotary movement of the dome.

The underside of the base is hollowed out and carries six

connection plates, each provided with two terminals. Fig. 28 shows the connections. The coil windings are brought out to terminals 3, 5 and 4, 6 respectively, while the frame connection is joined to terminal 3 and the insulated contact screw to terminal 1. Terminals 2 and 6 are bridged by a short length of insulated wire. Two metal straps are provided in order that the coils may be joined in series as indicated by full lines in Fig. 28, or in parallel as shown by dotted lines. For switchboard use the coils are usually joined in series in order to save battery power. For continuous ringing the bell leads are connected to terminals 7 and 8. Two Leclanché cells are provided for the bell local.

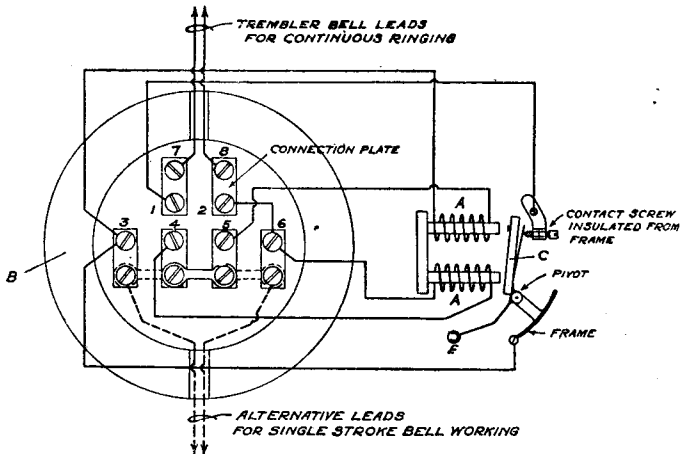

Fig. 28.—CONNECTIONS OF CIRCULAR TREMBLER BELL.

When the battery circuit is completed the path of the current is as follows:—

Terminals 3, 2 and 6, lower coil winding, terminals 4 and 5 with coils in series, upper coil winding, terminal 3, frame contact, armature spring, contact screw, thence terminals 1 and 7 to second bell lead. The electro-magnet is energized, its armature attracted and the contact screw is disconnected from the flat armature spring. The coils are now de-energized, the armature falls back, makes contact and is again attracted, thus giving repeated strokes of the hammer *E* on the bell dome as long as the external circuit remains unbroken.

If the bell is used for single stroke working the external leads are connected direct to the bell coils as shown by dotted lines.

**Bridging Coils and Retardation Coils** are described in pamphlet D.20.

**Differential Relay.**—The type of relay used for the receipt of lamp clearing signals on party line cord circuits on 50 and 100-line magneto boards is illustrated in Fig. 29. It consists of a double coil electro-magnet *A* with two windings, each  $1,000\Omega$  resistance. The soft iron cores carry an extension pin which fits into a corresponding hole in the armature *B*. The latter is prevented from actually touching the cores by two brass set screws with lock nuts *D*. A spiral spring which can be adjusted by screw *E* provides the tension, so that the armature normally rests against the upper contact piece *S*. A brass pillar *P* carries an adjustable contact at its upper end,

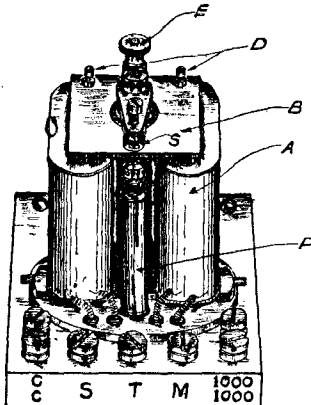

Fig. 29.—DIFFERENTIAL RELAY  
USED ON PARTY LINE  
CORD CIRCUIT.

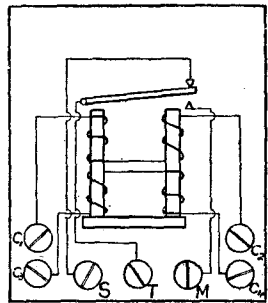

Fig. 30.—CONNECTIONS  
OF DIFFERENTIAL  
RELAY.

and this forms the contact for completing the local circuit. The armature is connected to terminal *T* by means of a flexible conductor. An iron case covers the whole relay and forms a magnetic sheath for the coils.

Fig. 30 shows the theoretical connections. One coil winding is connected to *C1* and *C2* and the other to *C3* and *C4*, whilst *S*, *T* and *M* are the spacing, armature tongue and marking contacts respectively. It will be seen that a current through either coil winding or both coils in series will energize the relay, whilst a current through both coils in parallel causes equal and opposite magnetic effects in the coils, or in other words the coils are differential.

**Junction Relays.**—The relays employed in connection with the plug ended cord circuit at the main exchange are of

similar appearance to that shown in Fig. 29. The relay which operates the lamp circuit is of the single make type and has a single winding of 250 $\Omega$ . The double make and break relay in the socket contact circuit is singly wound to a resistance of 1,000 $\Omega$ . Both relays are provided with soldering tags instead of the usual screw terminals.

**Lamps and Lamp Jacks.**—The lamp used in conjunction with the junction and party line cord circuit relay consists of a small carbon filament enclosed in an exhausted sealed glass tube. The ends of the filament are connected to copper wires, the latter being joined to platinum wires, where they pass through the ends of the glass tube, and soldered to the brass plates cemented to the sides of the tube as shown in Fig. 31 at *A*. One end of the glass tube is cemented to a small plaster of Paris or wood block which is painted with a distinctive colour to denote the voltage of the lamp. The colour used for a

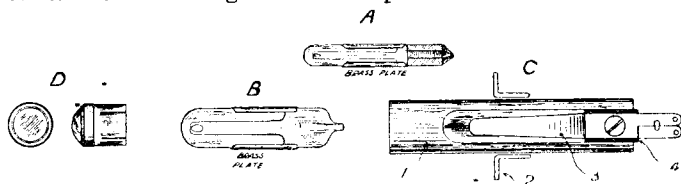

FIG. 31.—LAMPS AND PILOT LAMP JACK.

24-volt lamp is yellow. When incandescent the lamp takes about 0.050 ampère.

The pilot lamp, sometimes fixed above the jack panel on magneto boards, is similar in design to that already described, but is of larger dimensions and is not provided with the painted wood block, see *B* of Fig. 31. When incandescent the lamp takes about 0.140 ampère.

The pilot lamp jack shown in *C* of Fig. 31 is composed of a brass tube *1*, shaped as shown and fitted with brass lugs *2* which secure the jack to the woodwork. The lamp is held in position by two german silver springs *3* of equal length, insulated from each other by a block of ebonite *4*. These springs bear on the brass plates of the lamp, and are drilled at the rear to take the external connecting wires. To the forward end of the brass tube, a brass lamp cap, provided with an opal convex lens, is fitted, see *D* of Fig. 31. The cap protects the lamp from injury and serves to spread the light.

The lamp jack for the small lamp is similar in design to that of the pilot lamp jack.

The lamps not only provide a distinctive signal, but are easily replaced and occupy little space.

## CIRCUIT ARRANGEMENTS.

**Subscriber's Circuit.**—Each subscriber's circuit terminates on a 7-point jack and a  $100\Omega$  drop indicator, as depicted in Fig. 32. At the subscriber's end only the  $1,000\Omega$  magneto bell, which forms part of the telephone set, is in circuit between the *A* and *B* lines. The circuit connections are:—Subscriber's bell, *A* line, springs 1 and 2 of exchange jack to calling indicator, thence springs 3 and 4 of jack, *B* line and back to other side of subscriber's bell.

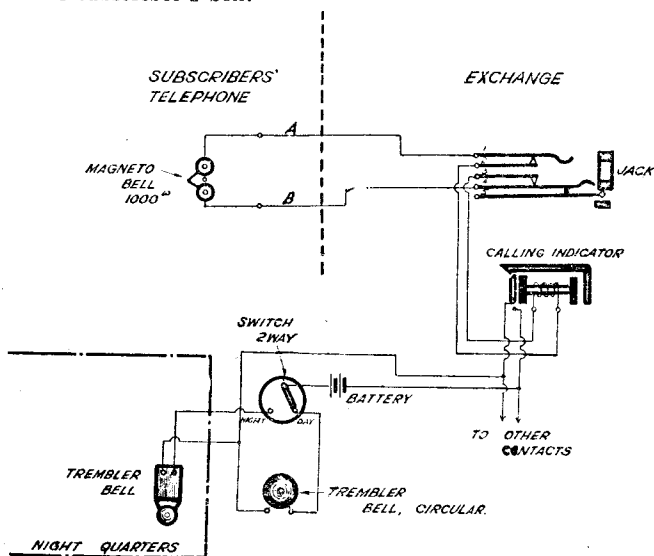

Fig. 32.—SUBSCRIBER CONNECTED TO MAGNETO EXCHANGE, SHOWING ALSO THE EXCHANGE ALARM CONNECTIONS.

The local circuit is from shutter contact of indicator to trembler bell, two-way switch in day position, battery, back to bare wire contact fixed under indicators. To enable calls to be dealt with at night a second trembler bell is usually fitted in the attendant's night quarters and is brought into circuit by turning the two-way switch to the left position.

At certain exchanges the day alarm bell is replaced by a pilot lamp operated by a low resistance single make relay

which forms part of the local circuit (Fig. 32A). The two way or tumbler switch in the "Day" position short-circuits the night bell. When a calling indicator is energized its shutter completes the circuit of the battery and relay, the armature

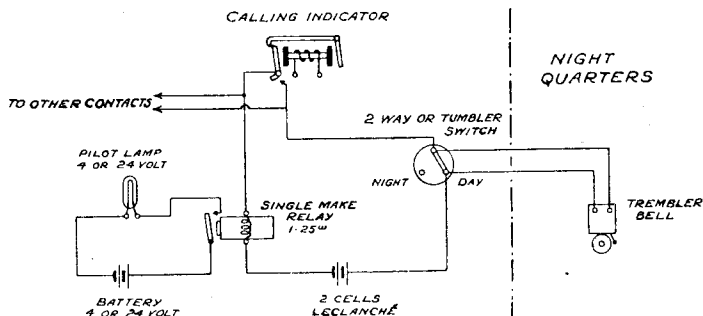

Fig. 32A.—ALTERNATIVE ARRANGEMENT OF ALARM CIRCUITS WITH LAMP SUPERVISION.

of the latter is attracted and closes the lamp circuit. With the switch in the "Night" position a call operates both the relay and trembler bell.

The contacts of all indicators are common to the local bell circuit. The alarm bell wire from each row of indicators is

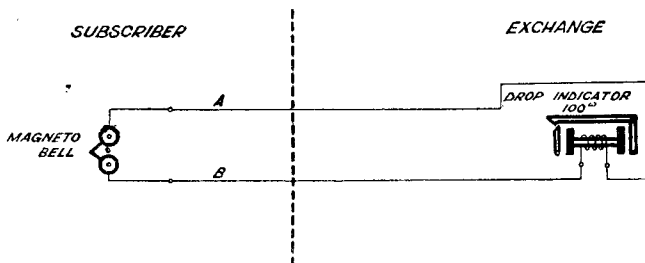

Fig. 33.—SIMPLIFIED CONNECTIONS OF SUBSCRIBER'S CIRCUIT.

taken to a separate terminal to facilitate the localization of faults. The terminals are mounted on a brass strip fixed to the inside of the switchboard.

The normal subscriber's circuit is shown in simplified form in Fig. 33. At one end is the magneto call bell, at the other a drop indicator, so that calls may be passed either way.

**Cord Circuit.**—Fig. 34 gives an explanatory diagram of the cord circuit, which enables the operator to answer a call, ring the wanted subscriber and place the two subscribers in communication; and also provides for a clearing signal at the termination of the conversation. The tip and sleeve of the answering plug are connected to the tip and sleeve of the calling plug *via* the contacts of the speaking and ringing key,

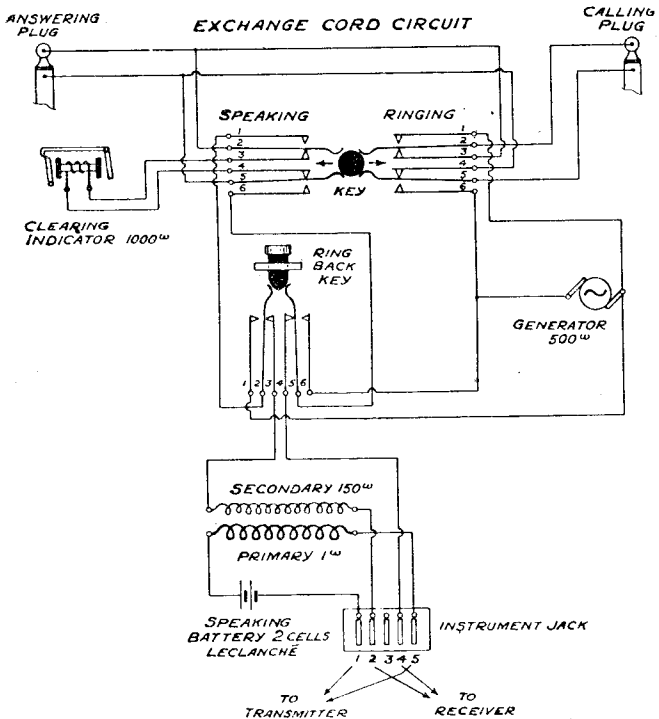

Fig 34.—EXPLANATORY DIAGRAM OF EXCHANGE CORD CIRCUIT.

whilst a  $1,000\Omega$  clearing indicator is bridged across the cords *via* inner springs of the speaking side of the key. Included in the circuit is a ring back key which, in its normal position, connects up the operator's set, but when the plunger is depressed joins up the generator to the answering plug *via* the speaking side of the speaking and ringing key. The primary and secondary of the operator's induction coil are joined to an



instrument jack. The transmitter and receiver are connected to an instrument plug. The insertion of this plug into the instrument jack completes the operator's connections.

Fig. 35 gives an alternative method of joining up the secondary and receiver of the operator's set where a 100-line board is installed. A differential induction coil takes the

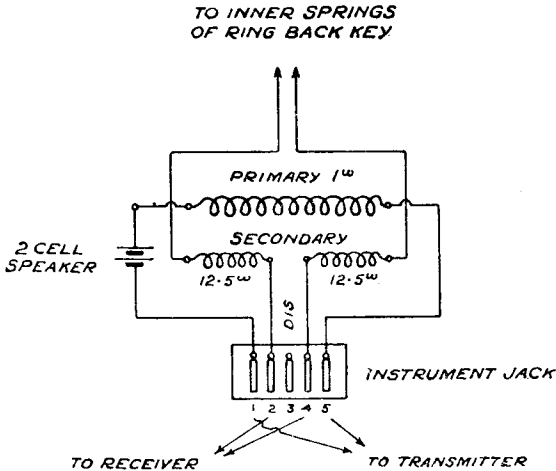

Fig. 35.—OPERATOR'S INSTRUMENT JACK CONNECTIONS WITH DIFFERENTIAL INDUCTION COIL.

place of the standard induction coil used on the 50-line board. The inner ends of the  $12.5\Omega$  secondary windings are connected to springs 2 and 4 of the instrument jack, whilst the outer ends are connected to inner springs 3 and 4 of the ring back

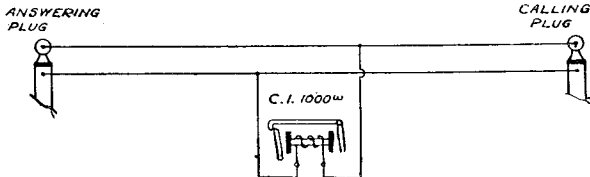

Fig. 36.—SIMPLIFIED DIAGRAM OF EXCHANGE CORD CIRCUIT.

key. The receiver is thus in the centre of the two secondary windings and can be converted readily for the multiple system of working by connecting spring 3 of the instrument jack to earth.

In Fig. 36 is shown a simplified diagram of the cord circuit with the clearing indicator *C.I.* in bridge across the two conductors.

**Two Subscribers Connected in Same Exchange.**—The connection of one subscriber to another on the same exchange is established in the following manner. The calling subscriber turns the handle of the telephone generator with the receiver still on its rest. Alternating currents are sent out to line which operate the exchange indicator and drop its shutter. This is shown in Fig. 37. The subscriber then lifts his receiver and

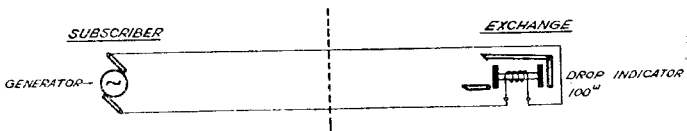

Fig. 37.—SUBSCRIBER CALLING EXCHANGE.

waits for a reply. The operator notes the number on the fallen shutter, inserts the answering plug—the rear one—of a pair of plugs and cords into the calling subscriber's jack and turns her speaking and ringing key into the speaking position *i.e.*, pushes the knob away from her, and also restores the shutter. The connections established are indicated in Fig. 38 and are as follows:—

Secondary of subscriber's telephone, *A* line spring 1 of jack, tip of answering plug, 2 and 1 speaking side of speaking and ringing key, springs 2 and 3 of ring back key, secondary and receiver of operator's set, springs 4 and 5 of ring back key, springs 6 and 5 of speaking side of speaking and ringing key, sleeve of answering plug, spring 4 of jack, *B* line, thence subscriber's receiver and other side of secondary. The caller's indicator is cut out of circuit. The skeleton connections are

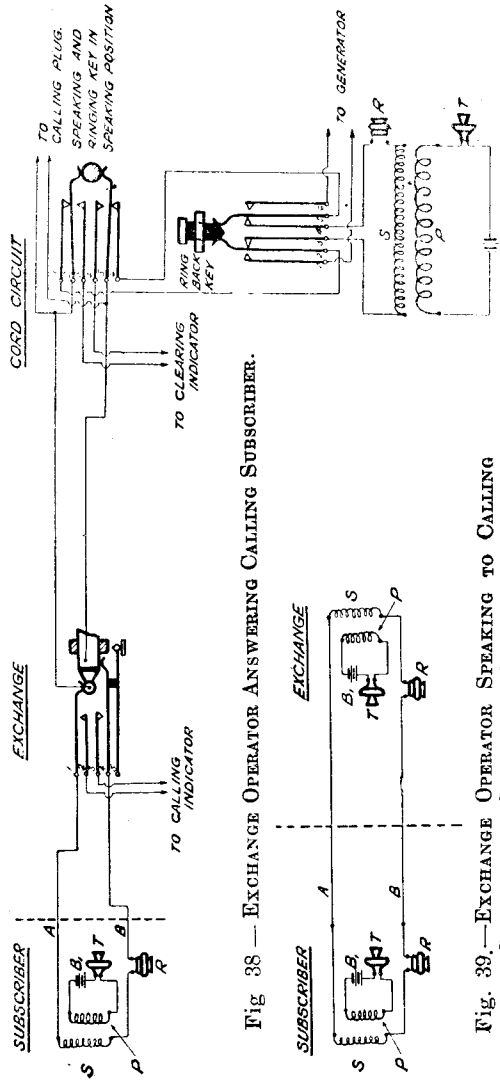

Fig 38 — EXCHANGE OPERATOR ANSWERING CALLING SUBSCRIBER.

Fig. 39.—EXCHANGE OPERATOR SPEAKING TO CALLING SUBSCRIBER. SIMPLIFIED CONNECTIONS.

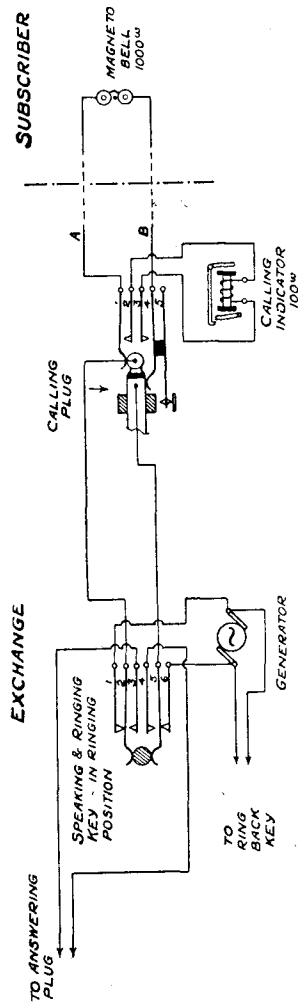

Fig. 40.—EXCHANGE OPERATOR RINGING "WANTED" SUBSCRIBER.

shown in Fig. 39, *S* being the secondary, *P* the primary, *B1* the speaking battery, *T* the transmitter, and *R* the receiver, in each case.

Having taken particulars of the call, the operator inserts the calling plug of the pair—the front plug—into the “wanted” subscriber’s jack, which cuts out of circuit his calling indicator, places the speaking and ringing key in the ringing position, *i.e.*, pulls knob of key towards her, and operates generator. Fig. 40 shows the connections set up, which are:—Generator to springs 1 and 2 of ringing side of speaking and ringing key, tip of calling plug, spring 1 of subscriber’s jack, *A* line, subscriber’s bell, *B* line, spring 4 of

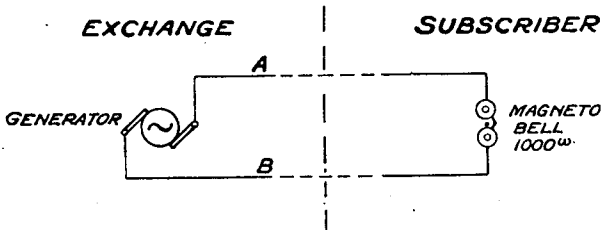

Fig. 41.—EXCHANGE OPERATOR RINGING “WANTED” SUBSCRIBER. SIMPLIFIED CONNECTIONS.

jack, sleeve of plug, springs 5 and 6 of speaking and ringing key ringing side, back to left side of generator. Fig. 41 indicates the skeleton connections.

The ringing side of the speaking and ringing key is “non-locking,” consequently, when the operator releases the knob, the key is automatically restored to the centre or through position.

The wanted subscriber answers the call by lifting his receiver and speaking. The operator places the speaking and ringing key in the speaking position, ascertains that the connected subscribers are in conversation and then restores the key to the “through” position. If the “calling” subscriber does not reply, the exchange operator, with the speaking and ringing key still in the speaking position, depresses the ring back

key and applies the generator to the caller's line (see Fig. 42). The connections then are:—From generator to springs 1 and 2 of ring back key, springs 1 and 2 of speaking side of speaking and ringing key, tip of answering plug, spring 1 of jack, A line, subscriber's telephone, B line, spring 4 of jack, sleeve of answering plug, springs 5 and 6 speaking side of speaking and ringing key, springs 5 and 6 of ring back key, thence to the other side of the exchange generator. The skeleton connections are similar to Fig. 41.

Care should be taken to withdraw temporarily the calling plug during the time the operator uses the ring back key, otherwise the "called" subscriber will receive unpleasant rings in his receiver. When the operator releases the ring back key it automatically restores the springs to their normal position. On the operator hearing both subscribers speak the speaking and ringing key is placed in the through position. The circuit connections as shown in Fig. 43 are:—

Secondary winding *S* of subscriber I telephone, A line, spring 1 of exchange jack, tip of answering plug, springs 3 and 2 of ringing side of speaking and ringing key, tip of calling plug, spring 1 of jack, A line, *S* of subscriber II telephone, receiver *R*, B line, spring 4 of jack, sleeve of calling plug, 5 and 4 ringing side of speaking and ringing key, sleeve of answering plug, spring 4 of jack, B line, to receiver *R* and secondary *S* of subscriber I. The primary *P*, transmitter *T*, and speaking battery *B1* form a complete primary or independent local circuit at each station. It will be noticed that from the tip of the answering plug there is a tap to springs 2 and 3 speaking side of speaking and ringing key, clearing indicator, and springs 4 and 5 speaking side of speaking and ringing key, back to sleeve of plug. This places the clearing indicator 1,000Ω across the A and B lines. A skeleton diagram of connections is given in Fig. 44.

On the completion of conversation both subscribers replace their receivers and ring off, *i.e.*, turn the handle of the generator. The skeleton connections during this operation are depicted in Fig. 45, which shows the clearing indicator *CI* in its operated position.

The operator seeing the clearing signal withdraws both plugs **BY MEANS OF THE COVER** and restores the clearing indicator shutter. The normal connections of both subscribers then obtain.

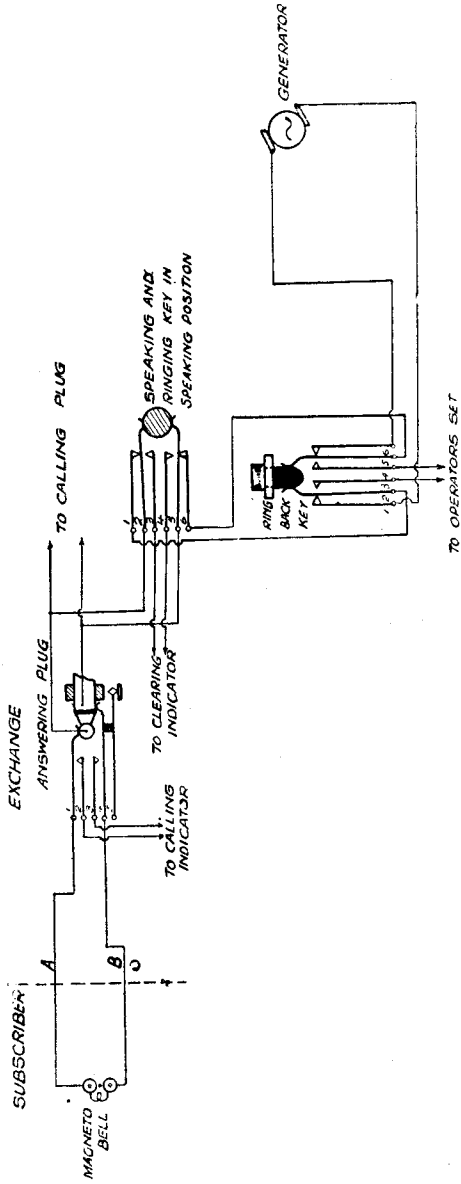

Fig. 42.—EXCHANGE OPERATOR RINGING CALLING SUBSCRIBER BY MEANS OF RING BACK KEY.

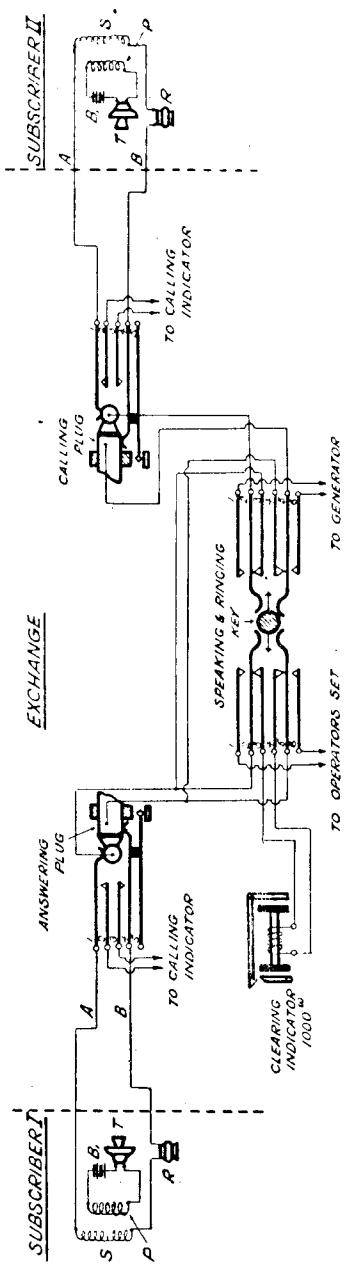

Fig. 43.—CORD CIRCUIT ARRANGEMENTS WITH TWO SUBSCRIBERS CONVERSING.

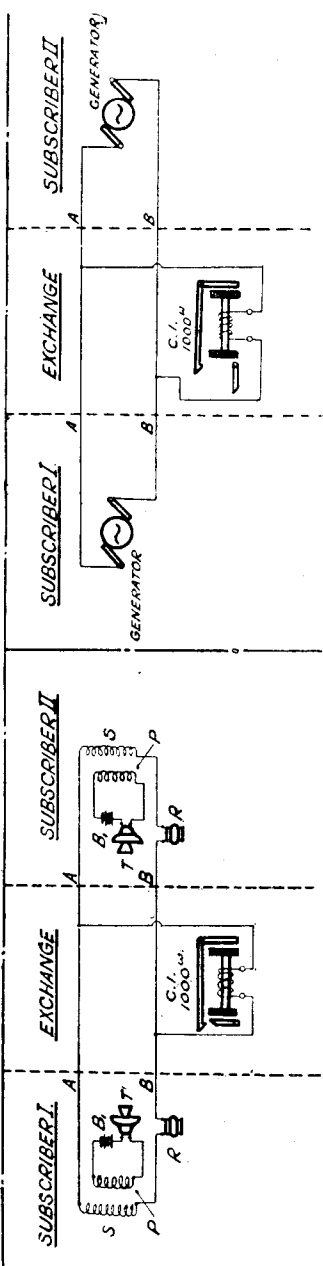

Fig. 44.—TWO SUBSCRIBERS CONVERSING. SIMPLIFIED CONNECTIONS.

Fig. 45.—SUBSCRIBERS RINGING OFF AFTER CONVERSATION.



## JUNCTION WORKING.

In order that subscribers connected to one exchange may communicate with subscribers at any other exchange, junction circuits are provided to a main exchange through which connections may be obtained to

- (a) Subscribers on other exchanges in the same area by means of junctions.
- (b) Subscribers at other distant exchanges using the trunk system of the country.

Junctions may be worked (1) *Incoming*, (2) *Outgoing*, (3) *Bothway*, the amount of traffic determining the class of circuit provided.

*Incoming* junctions are those over which calls originating at the distant exchange are passed. *Outgoing* junctions are those over which calls originating at the home exchange are passed. *Bothway* junctions are those which carry calls in either direction.

The apparatus at the incoming end includes an indicator for the receipt of calls, whilst at the outgoing end a jack only is usually provided.

For "bothway" working it is necessary to include calling apparatus at both ends, so that calls may be passed either way.

In Fig. 46 is shown a circuit *outgoing* at a main magneto exchange and *incoming* at a small magneto exchange. At the main exchange the line terminates on springs 1 and 4 of a 5-point jack, the inner springs 2 and 3 being connected to springs 1 and 4 of the second jack, and so on, depending upon the number of multiple jacks in use. The line is multiplied every four panels to enable all the operators to have access to it. The fifth point of each jack is connected to a common wire in order to provide an engaged test as described in pamphlet D.5. At the incoming end the line is joined to springs 1 and 4 of a 7-point jack, springs 2 and 3 being connected to an indicator 500 + 500Ω. It is not possible for the small exchange to call the main exchange.

**Setting up a Junction Connection.**—The method of operation is as follows:—A subscriber connected to the main exchange wishing to communicate with a subscriber at the small exchange first calls the main exchange.

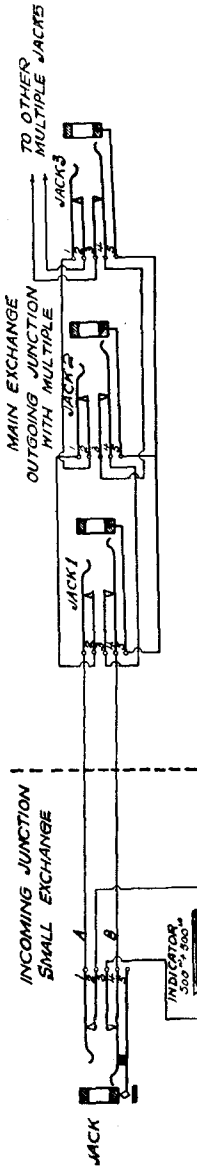

Fig. 46.—JUNCTION CIRCUIT OUTGOING AT MAIN AND INCOMING AT SMALL EXCHANGE. THEORETICAL CONNECTIONS.

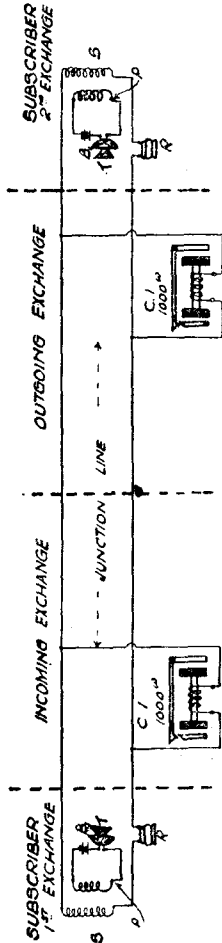

Fig. 47.—SIMPLIFIED CONNECTIONS OF JUNCTION CIRCUIT OUTGOING AT MAIN AND INCOMING AT SMALL MAGNETO EXCHANGE.

The operator replies, using the answering plug of a pair of plugs and cords for the purpose, and turns her speaking and ringing key to the speaking position. The cord circuit is similar to that described on page 28 except that 3-way plugs are used, the third conductor being appropriated for the engaged test. With the key still in the speaking position the operator tests the junction by touching the socket of one of the multiple jacks within her normal reach with the tip of the calling plug. The absence of a click in her receiver indicates that the line is disengaged, and the plug is then inserted in the junction jack. This engages the line and also cuts out of circuit all jacks beyond that particular operator's position, thus reducing the risk of interference to a minimum. The S and R key is then turned to the ringing side, which connects the exchange generator to the junction line. The method of extending the circuit at the small exchange is similar to that already described for connecting two subscribers, the only difference being that the answering plug is placed in the junction instead of a subscriber's jack.

Fig. 47 indicates the simplified circuit established. 1,000 $\Omega$  clearing indicators C.I. are across the A and B lines at both exchanges. Either subscriber ringing off with his generator actuates the indicator at both exchanges, thus providing for the simultaneous withdrawal of all plugs.

**Junction Outgoing at Small Magneto Exchange and Incoming at Main Magneto Exchange.**—At the small exchange an earthed 24-volt battery is joined to the centre point of a 500 + 500 $\Omega$  bridging coil, the outer ends being wired to the inner springs of a 7-point jack and the outer springs to the junction line, as in Fig. 48. At the incoming end the line usually terminates on a plug which normally rests in a socket provided with electrical contacts. The calling indicator is connected to the line *via* the outer contacts and armatures of a 1,000 $\Omega$  relay. The inner contacts of the latter are joined through a bridging coil to a 250 $\Omega$  relay and earth. This provides for the receipt of the automatic clearing signal. The circuit connections are:— From short spring of 7-point jack at outgoing exchange, A line, springs 2 and 3 of speaking side of S and R key, a and c of relay R1, through calling indicator to d and b of Relay R1, springs 4 and 5 speaking side of S and R key, B line to long spring of outgoing jack. From x there is a path to 3 and 2 ringing side of S and R key, thence tip of 3-way plug, and from 7 a connection to ring of plug *via* contacts 4 and 5 of

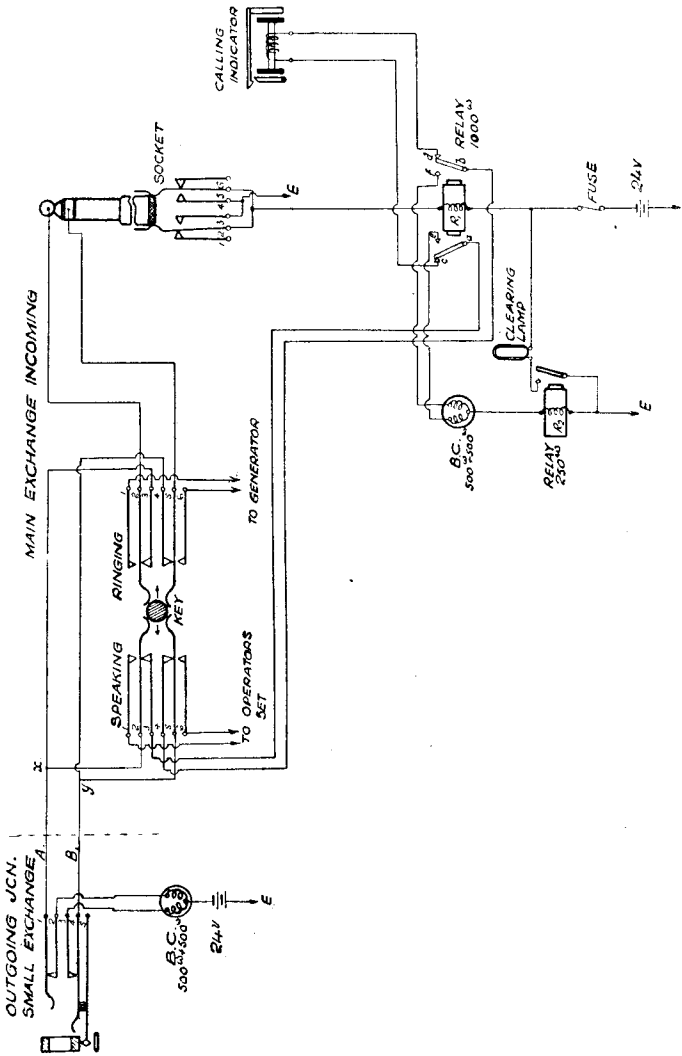

Fig. 48.—THEORETICAL CONNECTIONS OF JUNCTION CIRCUIT OUTGOING AT SMALL MAGNETO EXCHANGE AND INCOMING AT MAIN MAGNETO EXCHANGE.

same side of key. As the plug is resting in its socket contacts 3 and 4 are broken, consequently relay *R1* remains de-energized and the circuit of *R2* is broken at contacts *e* and *f*.

To pass a call from the outgoing to the incoming exchange, the operator at the former inserts the calling plug of an ordinary pair of plugs and cords into the junction jack, which disconnects the battery circuit, and applies the generator to the line. The calling indicator at Main is actuated and the operator turns her S and R key into the speaking position, takes the required number, makes the engaged test by lifting the plug and tapping the socket of jack of the wanted subscriber, and, if he be disengaged, inserts the plug and turns the S and R key into the ringing position. When the subscriber answers the simplified circuit is as shown in Fig. 49.

At the outgoing exchange the subscriber is connected direct to Main with a clearing indicator in bridge across the *A* and *B* lines. At Main the circuit is extended by means of the plug direct to the second subscriber. The lifting of the plug from its socket completes the circuit of relay *R1*, the current from the earthed 24-volt battery passing through contacts 3 and 4 and springs 2 and 5 of plug socket, thence *R1* back to negative pole of battery. *R1* is operated, armatures *a* and *b*, which are connected to the *A* and *B* lines of the junction *via* speaking key *SK*, make contact with *e* and *f*. The latter are joined to the double winding of bridging coil *BC*, whose inner ends are connected through the lamp clearing relay *R2* to earth. This places relay *R2* in the correct position for the receipt of clearing signals.

Fig. 50 shows the simplified connections of this part of the circuit. Contacts *c* and *d* of *R1* (Fig. 49) are now disconnected and the calling indicator cut out of circuit.

When the subscribers have finished their conversation each replaces his telephone on its rest and rings off. This actuates the clearing indicator at the outgoing exchange and the

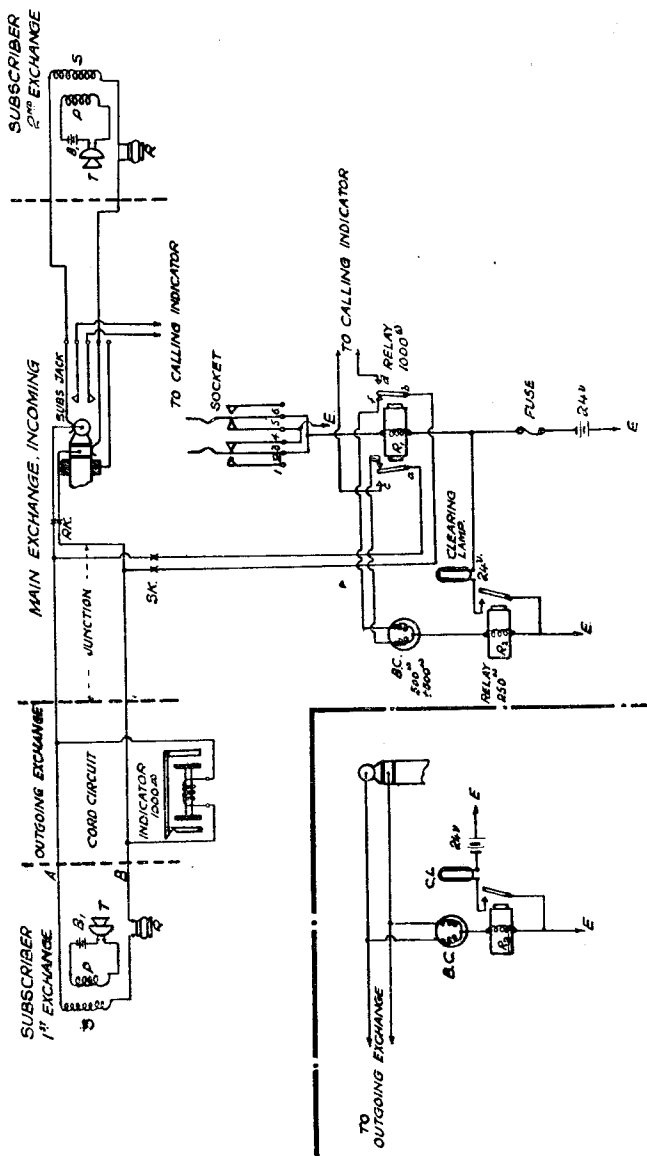

Fig. 50.—SIMPLIFIED DIAGRAM OF CLEARING ARRANGEMENT AT MAIN MAGNETO EXCHANGE.

Fig. 49.—TWO SUBSCRIBERS CONVERSING OVER A JUNCTION CIRCUIT OUTGOING AT SMALL MAGNETO EXCHANGE AND IN-COMING AT MAIN MAGNETO EXCHANGE. THEORETICAL CONNECTIONS.

operator withdraws her plugs from the subscriber's and junction jacks. The circuit arrangements are now as depicted in Fig. 51.

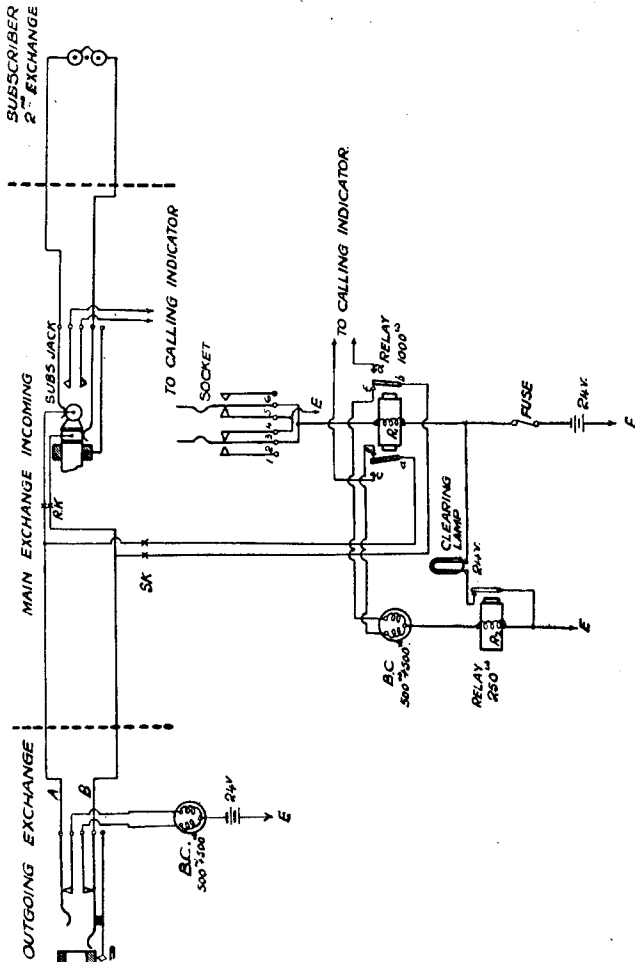

Fig. 51.—THEORETICAL CONNECTIONS SHOWING OUTGOING MAGNETO EXCHANGE CLEARING TO MAIN MAGNETO EXCHANGE.

At the outgoing exchange the withdrawal of the plug from the junction has restored the negative pole of the earthed 24-volt battery and bridging coil to the *A* and *B* lines, thus

completing the circuit through relay *R2* at Main. The path of the current is from positive pole of battery, relay *R2*, both coils of *BC* contacts *e* and *f* and armatures *a* and *b* of relay *R1*, *A* and *B* lines, outer to inner springs of outgoing jack, both windings of *BC*, thence to negative pole of battery. Relay *R2* is operated and its armature completes the lamp circuit. Current from the 24-volt battery at Main passes through the lamp which glows, thus indicating to the operator that the connection should be severed. When the plug is restored to its socket the circuit of relay *R1* is broken, the armatures *a* and *b* fall back and reconnect up the calling indicator *via* armature contacts *c* and *d*. The conditions in Fig. 48 then obtain.

**Bothway Junctions.**—Fig. 52 gives the arrangement. At the small exchange a 10-point break jack replaces the 7-point jack usually used for junctions, the two additional springs 6 and 7 being used to connect the earthed battery and retardation coil to the *B* line for clearing purposes. Condensers are interposed in each line in order to prevent false signals being given.

At the main exchange the circuit is arranged similarly to that shown in Fig. 48, but, in addition, the line is multiplied on the outgoing junction multiple before reaching the “Home” position. Calls incoming and outgoing at the main exchange are dealt with in an exactly similar manner to that already described for incoming and outgoing junctions. At the small exchange the 24-volt battery clearing current is connected to the *B* line only, consequently, with the plug at the main exchange in the subscriber’s jack, current will pass from 24V battery to relay *R2*, right coil of *BC*, contact *f* and armature *b* of relay *R1*, springs 4 and 5 of speaking side of *S* and *R* key, springs 3 and 4 of multiple jacks, *B* line, springs 7 and 6 of 10-point jack, thence to retardation coil and negative pole of battery. Although only the winding of the bridging coil connected to the *B* line at the main exchange is used for clearing purposes, the other winding of the coil is joined to the *A* line so that the electrical balance of the circuit in the speaking condition may not be disturbed.

For further systems of junction working at Magneto Exchanges the reader is referred to Addendum to Circular E.11 (P.O. Engineering Department Publication).

## DESCRIPTION OF SWITCHBOARDS.

**50-Line Switchboard.**—The general assembly of a 50-line floor pattern double cord magneto switchboard is shown in elevation and section in Fig. 53 and details have been added to enable the various items to be readily identified in the descrip-



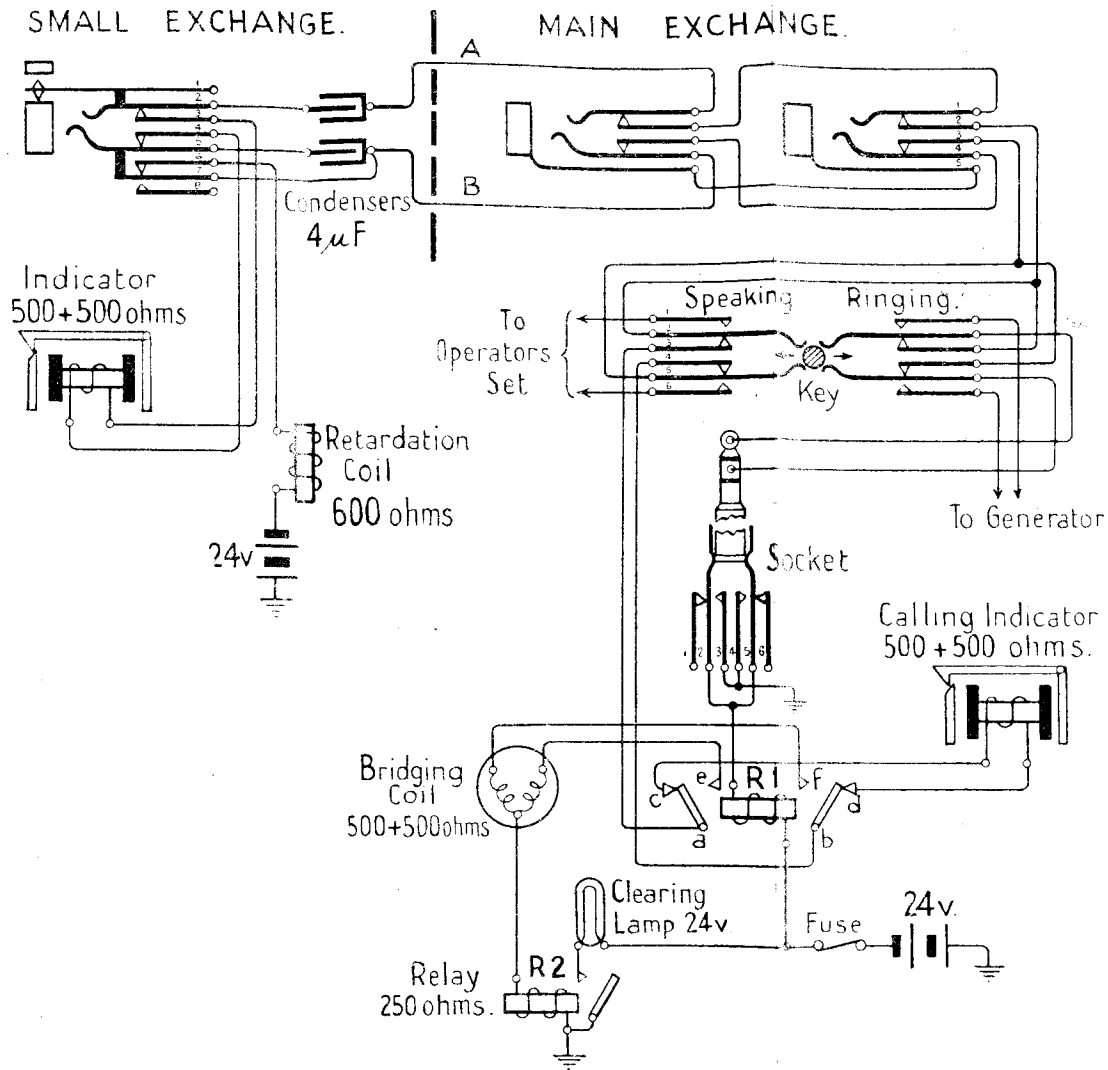

FIG. 52. Bothway Junction from Small Magneto Exchange to Main Magneto Exchange. Theoretical Connections

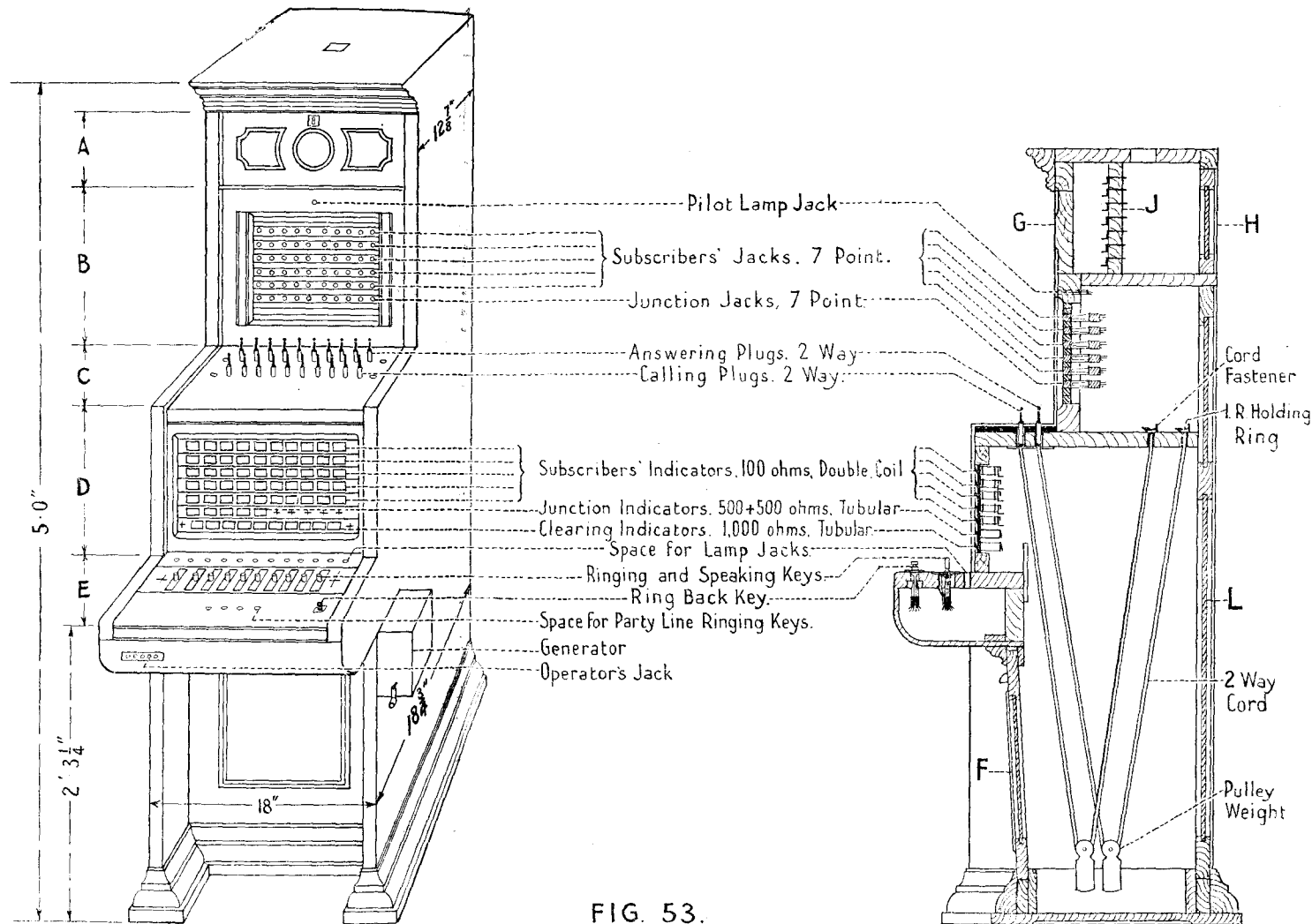

FIG. 53.

50 Line Magneto Switchboard. General Assembly.

Section.

tion of the apparatus parts previously given. The capacity and equipment are:—

	Junctions.	Subscribers.	Cord Circuits.
Capacity	10	50	12
Equipment	5 incoming 5 outgoing	50	10

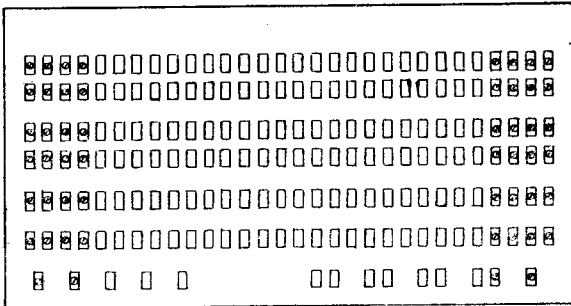

Fig. 54.—CONNECTION RACK.

VIEW FROM FRONT OF SWITCHBOARD.

At the top of the board is a compartment marked *A* fitted with a wooden vertical dividing panel *J* furnished with soldering tags. This is termed the connection rack. Access is ob-

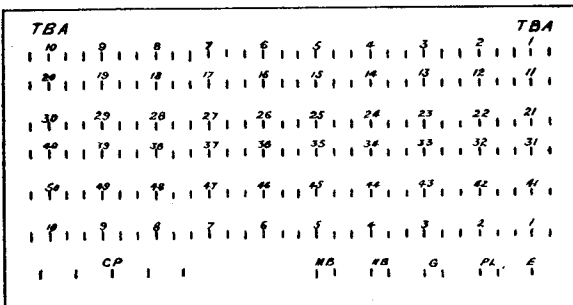

Fig. 55.—CONNECTION RACK.

VIEW FROM REAR OF SWITCHBOARD.

tained by means of front and rear doors *G* and *H*. A plan of the arrangement of the soldering tags is given in Figs. 54 and 55. Fig. 54 shows the tags as viewed from the front and Fig. 55 the tags and markings as seen from the back of the switchboard.

The tags are arranged in six rows of ten three numbered

to correspond to the jack numbering and one row for miscellaneous purposes. The first five rows are allotted to subscribers and the sixth to junctions. The wires from the short springs of the jacks are connected to tags marked *A* (Fig. 55), the wires from the long springs of the jacks to the tags marked *B*, and the wires from the test springs of the jacks to the tags marked *T*. The seventh row has five tags *CP* connected to the centre point of the junction indicators, two tags *MB* to the microphone circuit, two tags *NB* to the night bell, two tags *G* to the generator, two tags *PL* to the pilot lamp jack, and one tag *E* for an earth connection.

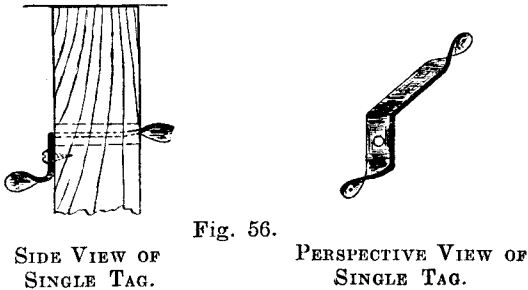

Fig. 56.

SIDE VIEW OF  
SINGLE TAG.PERSPECTIVE VIEW OF  
SINGLE TAG.

Fig. 56 gives two views of a brass tag which is drilled and tinned at both ends to receive the soldered connecting wires.

Specimen wiring connections from the tags for each type of circuit are given in Fig. 57. The tags marked *T*, *E* and *CP* are wired from the front tags to the apparatus, but are not ordinarily joined up at the back unless multiple working or special junction systems are required.

Reverting to Fig. 53, the jack frame *B* is equipped with jacks and wired for the full capacity of the board. Strips of ebonized hardwood fill the spaces not occupied by the jack strips. A jack or the pilot lamp is provided at the top of the frame.

Plug shelf *C* is bored with twelve pairs of plug holes, one pair at each end being normally plugged up. The shelf is covered with red fibre. The cords from the plugs are connected to cord fasteners mounted on a horizontal board behind the jacks.

The indicator frame *D* is wired for the full capacity of the board. The junction strip has five spare indicator spaces marked + which can be filled up if required. At either end of the clearing indicator strip is space for one additional indicator.

The key shelf *E* is prepared for twelve speaking and ringing

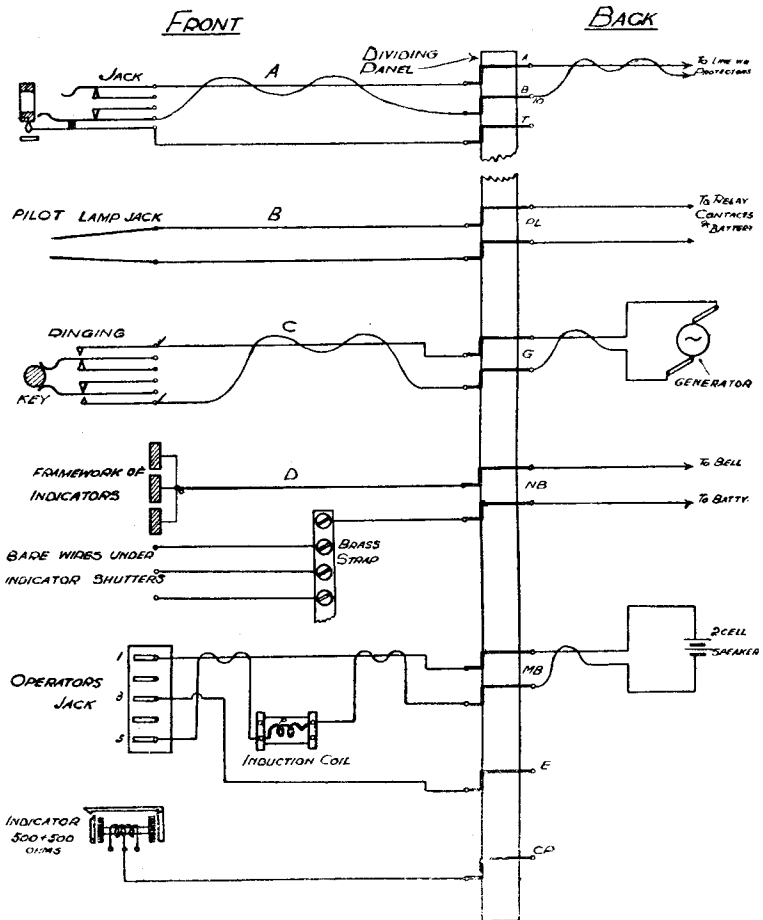

Fig 57.—SPECIMEN WIRING CONNECTIONS FROM CONNECTION RACK TO SWITCHBOARD APPARATUS.

keys but normally is only equipped with ten. The spaces for lamp jacks and party line keys are plugged up, but are available if required for party line working. The key shelf is hinged so that the internal wiring may be easily inspected.

Below the key shelf is a loose panel *F*. A removable panel *L* is also provided at the rear of the section. This encloses the space from the top of the jack strips to the bottom of the cords and provides a ready means of access to the fittings and wiring.

The wire used for the internal wiring of the board is  $9\frac{1}{2}$  lb. copper, silk and cotton covered, treated with best beeswax. Twisted pairs are provided for all speaking circuits and generator leads. All wires after connection to the apparatus are formed up and laced into cables and given a thin coating of shellac varnish. In all cases where it is necessary to solder connections no flux other than resin should be used. The wiring from the front tags (Fig. 54) to the various fittings is completed before the board is despatched from the Stores Depôt, whilst all wiring to the rear tags is done by the installers on the spot.

**100-Line Switchboard.**—The general assembly of a 100-line floor pattern double cord magneto switchboard is shown in elevation in Fig. 58. The view to the right in Fig. 53 also serves as a sectional elevation.

The description of the 50-line board applies generally to the 100-line board, with the exception that the capacity and equipment are increased as follows:—

	Junctions.	Subscribers.	Cord Circuits.
Capacity	20	100	18
Equipment	10 incoming 10 outgoing	100	14

Single coil  $100\Omega$  tubular indicators replace the double coil type used on the 50-line board, and a differential induction coil is substituted for the  $150 + 1\Omega$  standard coil, otherwise there is no change in the types of apparatus assembled.

## PARTY LINES.

The party line system provides for connecting from two to ten subscribers on one common line to the exchange, worked

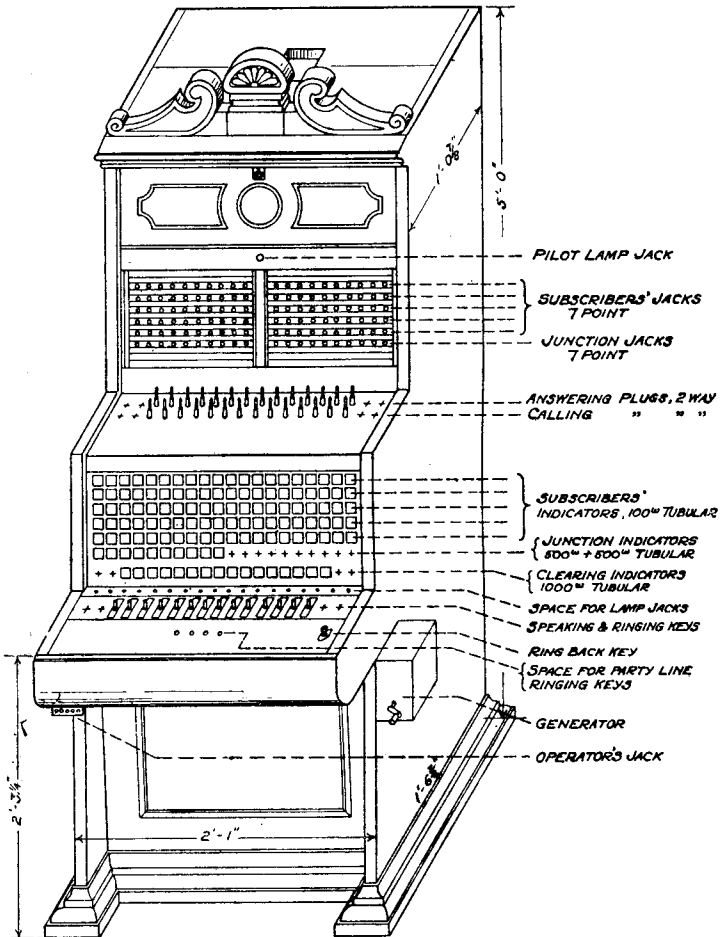

Fig. 58.—100-Line MAGNETO SWITCHBOARD. GENERAL ASSEMBLY.

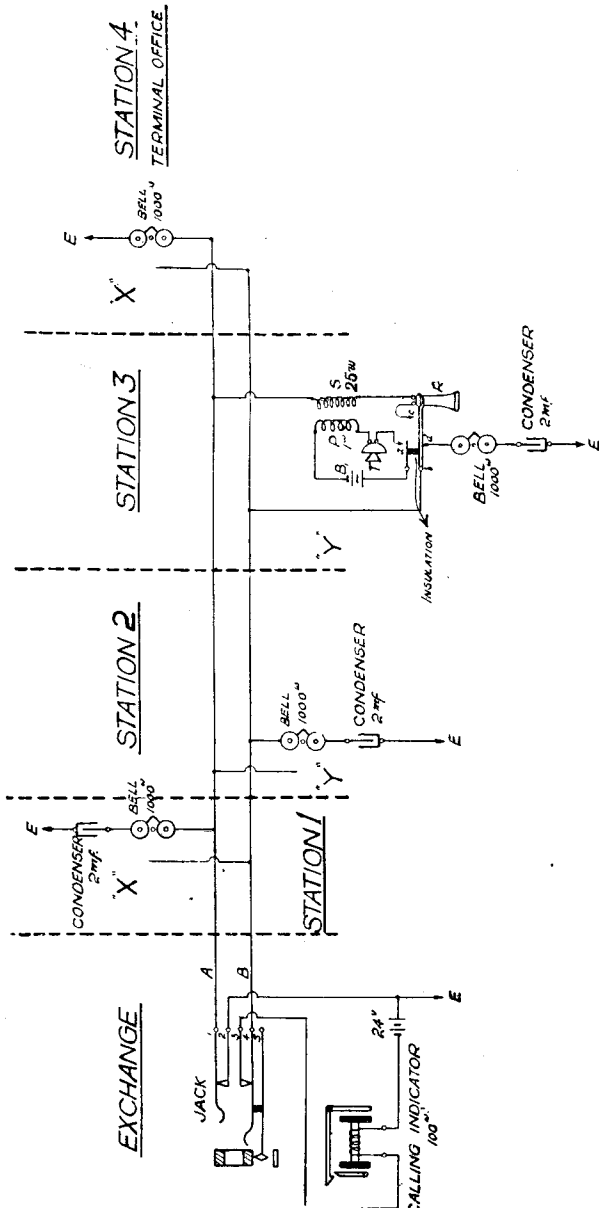

Fig. 59.—4-PARTY LINE CIRCUIT JOINED TO MAGNETO EXCHANGE. NORMAL CONNECTIONS.



on Common Battery Signalling principles. Fig. 59 shows the arrangements for four stations. At the exchange a 24-volt battery is interposed between spring 2 of the jack and the indicator, the positive pole being earth connected. The subscriber's instrument bells are connected in series with condensers between the *A* or *B* line and earth.

Those subscribers whose bells are connected to the *A* line are termed *X* subscribers, whilst those joined to the *B* line are known as *Y* subscribers. At the *X* terminal station the condenser is omitted in order to provide for automatic clearing

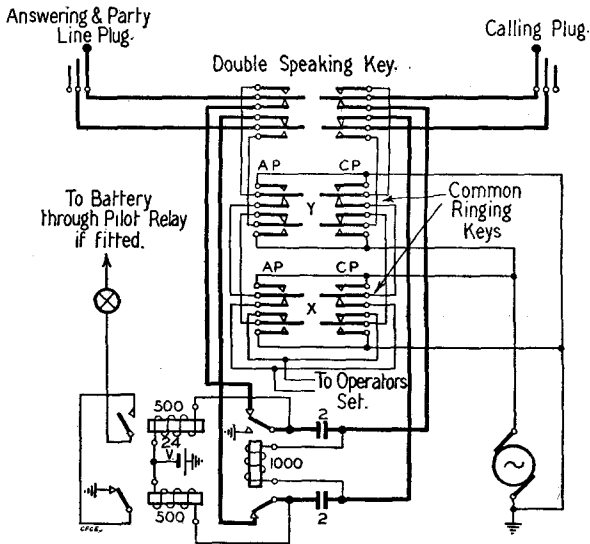

Fig. 60.—PARTY LINE CORD CIRCUIT AT SMALL MAGNETO EXCHANGE, SHOWING FULL RINGING FACILITIES.

to the exchange. In the diagram, stations 1 and 4 are *X* and 2 and 3 *Y* subscribers, the latter showing the telephone connections in detail, *P* being the primary and *S* the secondary of the induction coil, *B1* the speaking battery, *T* the transmitter, *R* the receiver, and *b*, *a*, *c*, *d* the telephone lever and its contacts.

The cord circuit used is shown in Fig. 60. A *double* speaking key replaces the ordinary speaking and ringing key. The ringing keys, which provide for *X* and *Y* ringing, are common to all the party line cords and are wired so that the operator's speaking set is cut out of circuit while ringing. Across the

answering cord two  $500\Omega$  relays are connected in series with the centre point joined to an earthed 24-volt battery. A lamp is joined in series with the relay contacts. This provides for an automatic clear from the party line.

Across the calling cord is a  $1,000\Omega$  relay for the receipt of the ring off signals from magneto subscribers. When this relay is operated it disconnects the answering side of the cord circuits, thus preventing a magneto ring off signal from ringing the party line subscribers' bells. At the same time the upper  $500\Omega$  relay is earthed bringing in the lamp. Condensers are interposed in the cord circuit in order to confine the 24-volt battery circuit to the answering plug side. Fig. 61 shows the simplified connections.

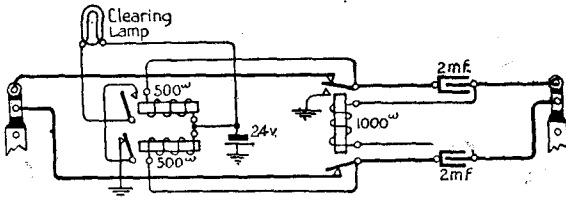

Fig. 61.—PARTY LINE CORD CIRCUIT AT SMALL MAGNETO EXCHANGE. SIMPLIFIED CONNECTIONS.

To call the exchange the subscriber—say, station 3, Fig. 59—lifts his receiver and loops the line. Current flows from the 24-volt battery to springs 2 and 1 of exchange jack, A line, secondary coil  $S$ , receiver  $R$ , contact  $c$  and lever  $b$  of telephone, B line, springs 4 and 3 of jack, thence calling indicator to negative pole of battery. The indicator coil is energized and its armature releases the shutter, which falls and indicates a call. The operator inserts the "Party Line" plug in the caller's jack. This joins springs 1 and 4 to the tip and sleeve of plug, and disconnects the calling indicator and battery. The shutter is restored. In turning the double speaking key both sets of springs are operated and the operator's set is connected *via* keys  $Y$  and  $X$  to the subscriber's line. At the same time the clearing apparatus is cut out of circuit. Fig. 62 gives these connections.

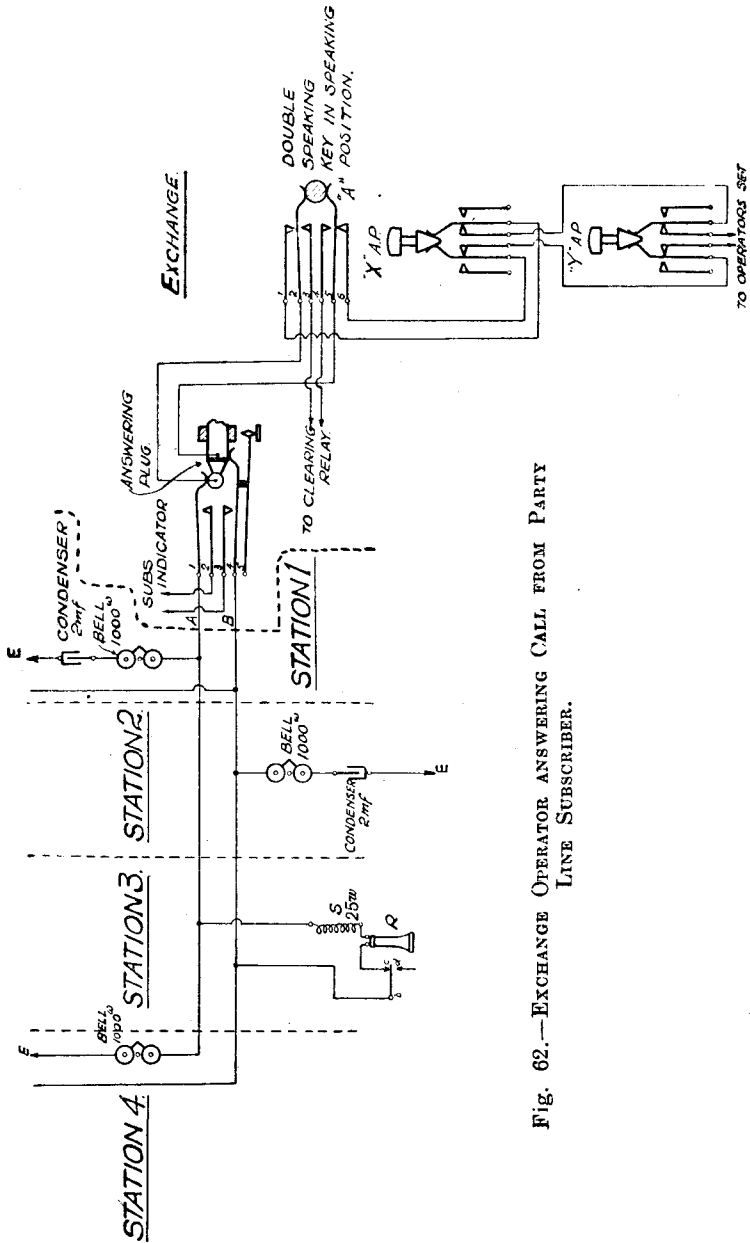

Fig. 62.—EXCHANGE OPERATOR ANSWERING CALL FROM PARTY LINE SUBSCRIBER.

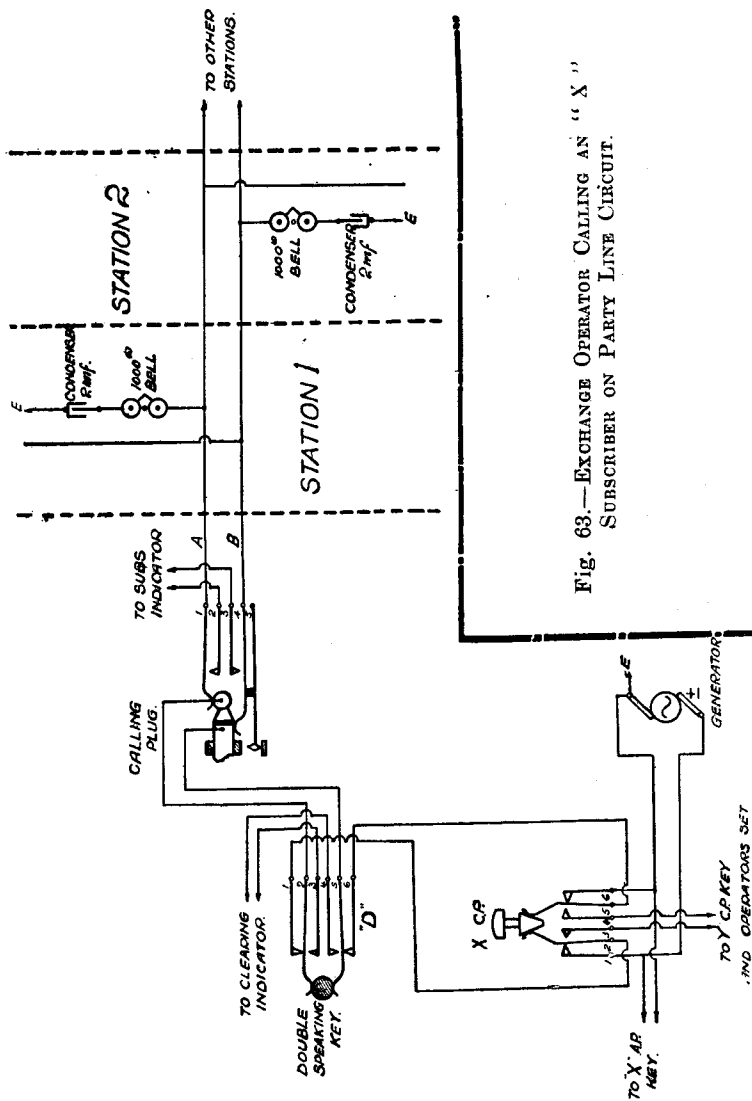

Fig. 63.—EXCHANGE OPERATOR CALLING AN "X"  
SUBSCRIBER ON PARTY LINE CIRCUIT.

Having taken the particulars of the call, the calling plug is inserted in the wanted subscriber's jack, the proper ringing key thrown and the generator applied to the line. Fig. 63 gives connections when an "X" subscriber is being rung. The calling plug connects up the line springs of the jack and also causes the inner springs to break from the outsiders, which disconnects the called subscriber's indicator. The circuit con-

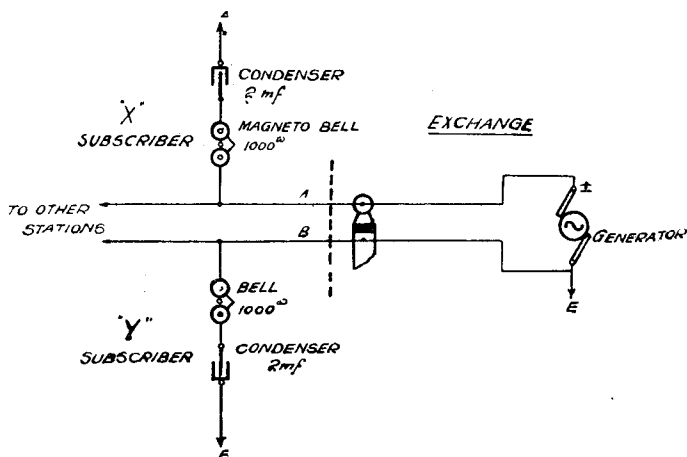

Fig. 64.—EXCHANGE OPERATOR CALLING "X" SUBSCRIBER ON PARTY LINE CIRCUIT. SIMPLIFIED CONNECTIONS.

nections are:—Generator, springs 1 and 2 of X C P (X position of key calling plug side) springs 1 and 2 of D, tip of calling plug, spring 1 of jack, A line, station I bell, condenser and earth. The earthed side of generator is joined up to springs 6 and 5 of X C P, sleeve of plug, jack spring 4 and B line.

Fig. 64 shows the simplified connections of the X subscriber's calling circuit.

If the call is for a Y subscriber key Y (Y key calling plug side) Fig. 60 is used instead of X C P, thus connecting the

generator to the *B* line and earthing the *A* line. Fig. 65 gives the simplified circuit connections.

When the number of stations exceeds two, code ringing is employed. All *X* subscribers receive the generator rings sent over the *A* line and reply to calls for their own station only; similar remarks apply to rings sent over the *B* line.

In Fig. 66 a party line subscriber is shown speaking to a magneto subscriber, *P* being the primary and *S* the secondary

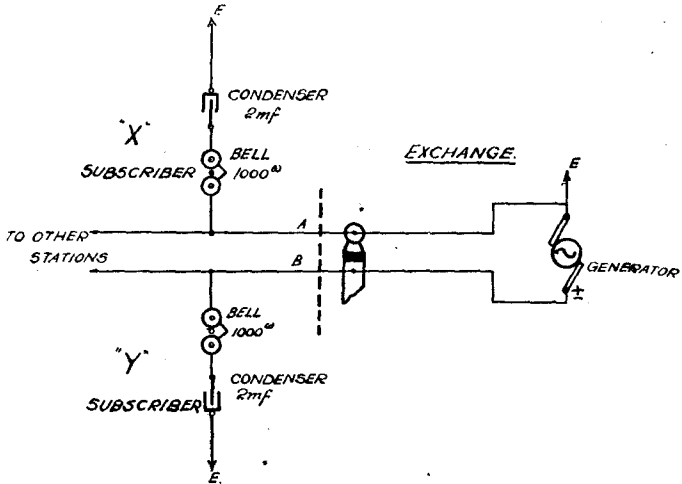

Fig. 65.—EXCHANGE OPERATOR CALLING A "Y" SUBSCRIBER ON PARTY LINE CIRCUIT. SIMPLIFIED CONNECTIONS.

of induction coil, *B1* the speaking battery, *T* the transmitter and *R* the receiver in each case. The 24-volt earthed battery circuit is completed through the bell at station IV and current flows *via* the bell and *A* line to the junction for station III instrument, where it splits, one portion traversing the *A* line and upper exchange relay and the other part through the secondary *S*, receiver *R*, contact *c* and lever *b* of telephone, *B* line, and lower relay, where the current unites with that in the upper relay, back to negative pole of battery. The upper and the lower relays are energized and the lamp is, therefore, disconnected from the battery.

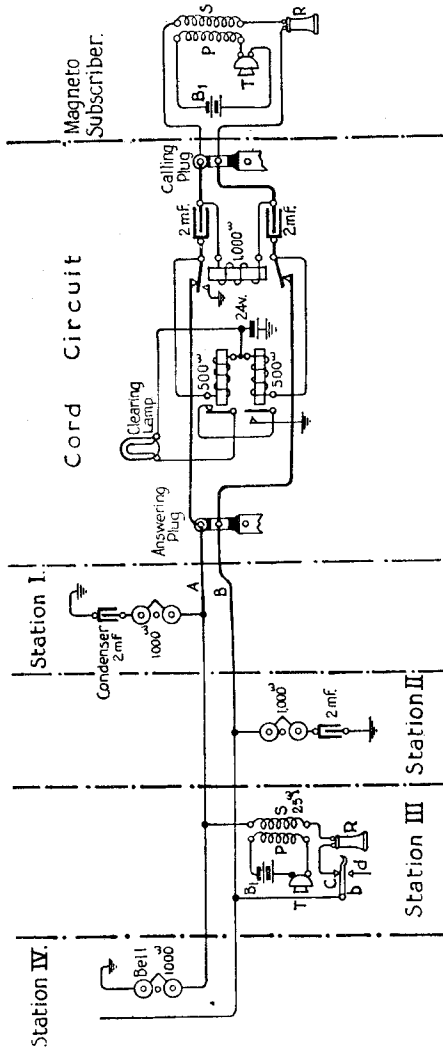

Fig. 66. MAGNETO SUBSCRIBER SPEAKING TO PARTY LINE SUBSCRIBER. EXCHANGE CORD CIRCUIT SHOWING "RING OFF" ARRANGEMENTS.

When station III restores his receiver, the conditions are similar to those of station II. Current now passes from the earthed battery, bell of station IV, A line, upper relay and back to the negative pole of battery. The upper relay remains energized but no current flows through the lower relay and its armature falls back and completes the lamp circuit. The lamp glows and indicates to the operator that the connection may be severed. If two party lines are connected together, the operator relies only on the lamp clear from the calling subscriber.

A party line subscriber wishing to communicate with another subscriber on the same circuit must first call the exchange, and the operator there will, after asking the calling subscriber to replace his receiver while she rings the wanted subscriber, proceed to call in the usual way. The answering plug should be left in the party line jack during conversation to obviate a permanent call at the exchange. When both subscribers have restored their receivers a clear signal is given to the exchange.

#### SMALL MAGNETO EXCHANGE METHOD OF INSTALLATION.

In designing the lay-out of a small magneto exchange several engineering and traffic requirements have to be considered, and it is not possible in all cases to arrange for an ideal scheme owing to the position of the exchange premises and the accommodation available therein.

The following are the chief considerations:—

(a) The position of the switchboard should be well lighted, preferably from the side or above.

(b) Space for additional boards in the same line to meet anticipated telephone development.

(c) Arrangement of apparatus to give the maximum floor space for operating.

(d) The position of the protector frame. This should be arranged so that it is as near as possible to the point of entrance of the external cables, whilst allowing for a minimum of internal cabling.



(e) Space for an additional protector frame to meet anticipated development.

A typical lay-out which embodies the above principles as far as circumstances will permit is depicted in Fig. 67.

A raised wooden floor, provided with hinged flaps to give access to the cables carried under it, accommodates the 240-

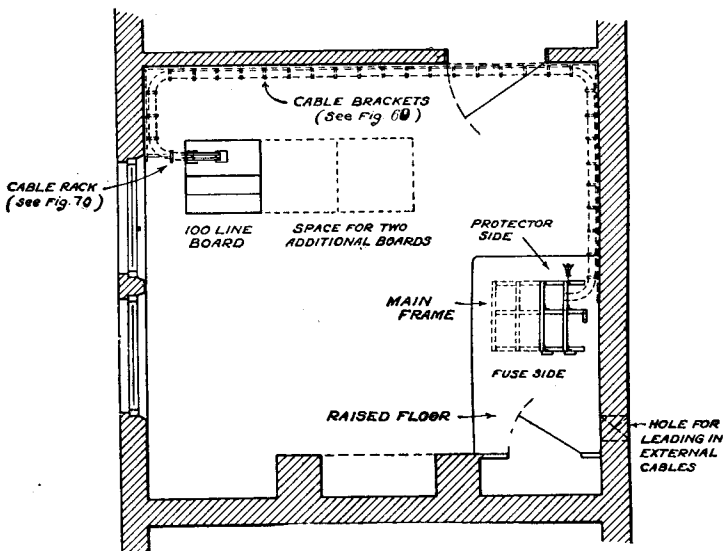

Fig. 67.—PLAN SHOWING LAY-OUT OF SMALL MAGNETO EXCHANGE SWITCHROOM.

line main frame (described in pamphlet D.18) and space is provided for a second frame as shown by dotted lines in the figure. The 100-line switchboard is placed in line with the window, and space is available for two additional 100-line boards.

The 200-pair lead covered cable is brought in through the aperture in the wall and connected to a short length of silk and cotton covered cable. The latter is terminated on the fuse side of the main frame. Sufficient fuse mountings, each carrying 20 circuits, are provided so that a fuse may be fitted in *every* line entering the exchange.

The illustration to the right in Fig. 68 shows the arrangement of the 200-pair silk and cotton cable. The lead is stripped from the cable just below the bottom fuse mounting on the frame and the conductors are split into two groups, 120 pairs serving bar No. 1 and the remainder bar No. 2. Each group is carried up its proper vertical rib of the frame, fanned out and connected to the fuse mountings and carefully and neatly laced with twine. The pairs are numbered from top to bottom of each bar.

The protector side of the main frame, shown at the left side of Fig. 68, is equipped with six "protectors and heat coil mountings" each carrying 20 circuits. The top mounting is allotted to junctions and miscellaneous circuits, and the five mountings below accommodate 100 subscribers' lines, the present capacity of the switchboard. The 42-wire switchboard cables enter at the top of the frame and are neatly secured to the horizontal bars. Each cable fills one protector mounting, with two spare wires for replacement purposes in case of faults. It will be noticed that the numbering is from the top to the bottom of this side of the frame.

The plan at the bottom of Fig. 68 shows the positions of the line and switchboard cables, and also the jumper wires.

The cross connections between fuse and protector strips are made by lengths of twin  $12\frac{1}{2}$  lb. enamelled and flameproof wire carried across the frame *via* the jumper rings.

The cables from the main frame to the switchboard are supported on overhead wall brackets, spaced about 9" apart, screwed to a wood rail which is fixed to the walls of the room just below the ceiling. A short length of iron rack forms the support from the last wall bracket to the main frame and top of the switchboard respectively.

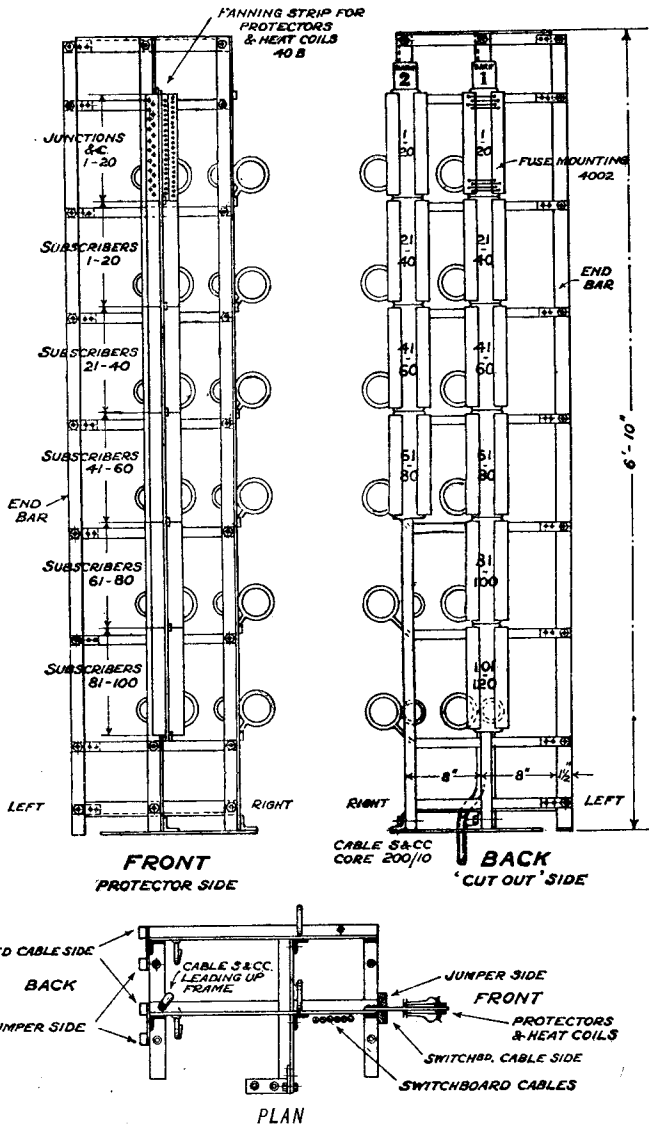

Fig. 68.—MAIN FRAME, 240 LINES, GIVING DETAILS OF THE NUMBERING OF LINE AND SWITCHBOARD CABLES.

Details of the wall bracket are given in Fig. 69. The bracket is made of iron of the dimensions shown and it will accommodate the cables necessary for three complete switchboards. The

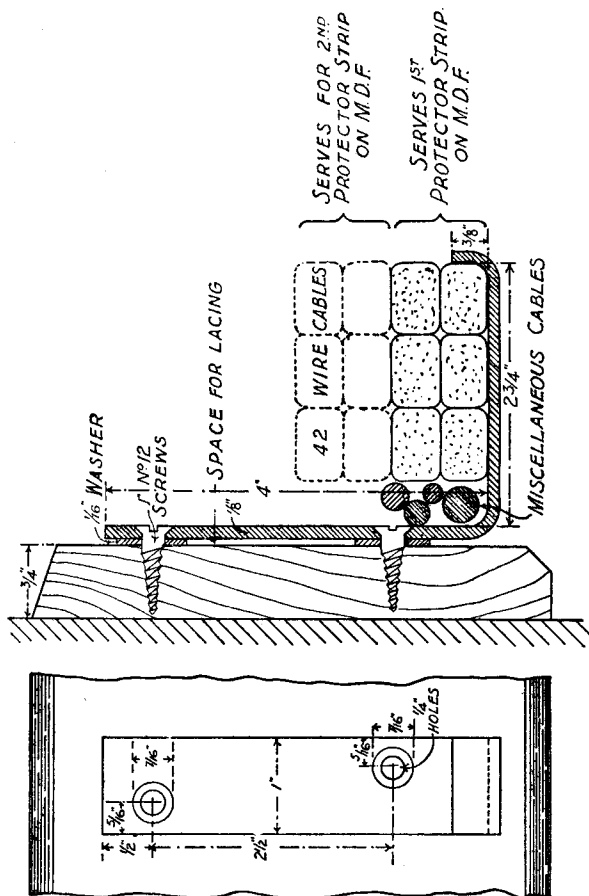

Fig. 69.—WALL BRACKET FOR SWITCHBOARD CABLES.

space between the switchboard cables and bracket vertical accommodates the battery cable and leads for miscellaneous circuits. Two wood screws secure the bracket to the wood rail.

An end view of the cable rack is shown in Fig. 70. The rack is made up of  $\frac{3}{8}$ " by 1" iron U bearers held in position and strengthened with a bottom longitudinal supporting rib which extends beyond the last U bearer.

At the main frame one end of the supporting rib is screwed to the wood rail and the other bolted to the top of the main frame.

An elevation showing the arrangement of the rack from the wall to the top of the switchboard is given in the upper part of Fig. 71, whilst below is a plan of the cables and their supports adjacent to the switchboard.

Inside the switchboard the cables are divided into two groups, and each group is then carried on alternate sides of

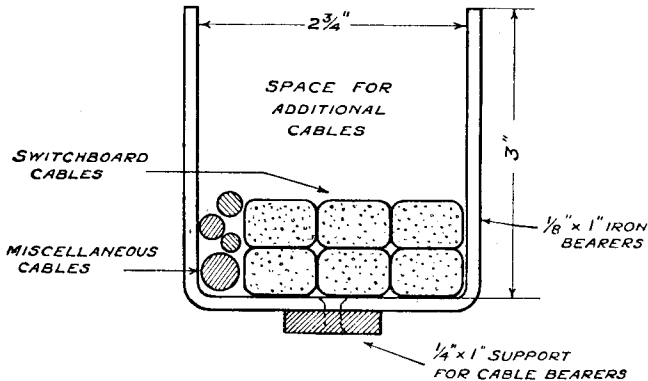

Fig. 70.—CROSS-SECTION OF CABLE RACK FOR SWITCHBOARD CABLE.

the woodwork to a point opposite the particular row of tags. Leather cleats secure the cables to the woodwork. Each cable is then stripped of its covering and turned so that it is in line with the tags and about  $1\frac{1}{2}$ " from them. The wires are connected in pairs to the A and B tags, the test tag T (Fig. 55) not being used. The stripped cable is then neatly laced. Cored solder is used to solder the wires to the tags.

*Battery Accommodation.*—The accommodation necessary varies considerably, being dependent on the number of subscribers' party line circuits and whether the junctions are worked automatic signalling or not. It is, however, very important that the batteries should be placed in a *well ventilated and efficiently lighted situation where they can be readily inspected and be tested* (as described in pamphlet A2) with ease.

For further details of internal cabling and wiring of telephone exchanges, see pamphlet D.17.

**Power Supply.**—See pamphlet G.2.

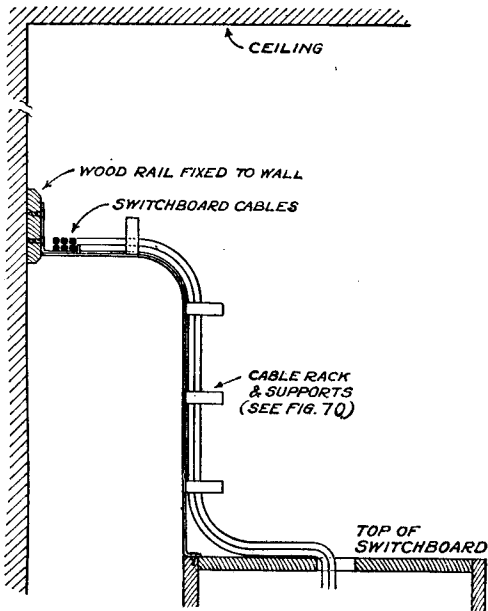

ELEVATION AB

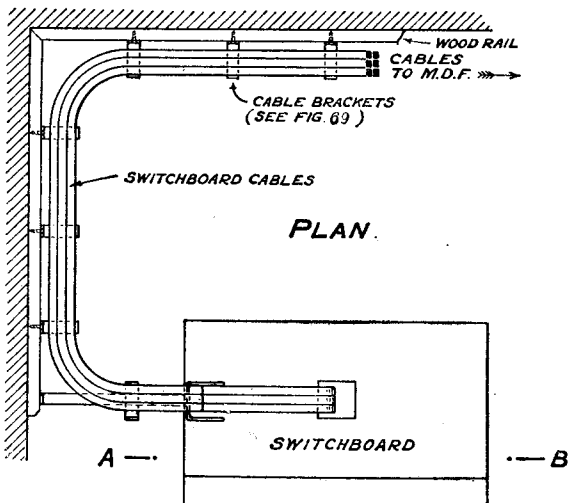

PLAN.

Fig. 71.—STRONG CABLE SUPPORT FROM WALL OF SWITCH-ROOM TO TOP OF SWITCHBOARD, AND PLAN OF CABLE AND SUPPORTS ADJACENT TO SWITCHBOARD.

===== LIST OF =====

# Technical Pamphlets for Workmen

(Continued.)

---

## **GROUP D.** (Continued.)

20. Superposed Circuits. Transformers. Bridging Coils and Retardation Coils.
21. Call Offices.

## **GROUP E.**

1. Automatic Telephony : Step by Step Systems.
2. Automatic Telephony : Coder Call Indicator (C.C.I.) Working.
3. Automatic Telephony : Keysending " B " positions.

## **GROUP F.**

1. Subscribers' Apparatus. Common Battery System.
2. Subscribers' Apparatus, C.B.S. Part I—C.B.S. No. 1 System.
3. Subscribers' Apparatus. Magneto.
4. Private Branch Exchanges—Common Battery System.
5. Private Branch Exchange—C.B. Multiple No. 9.
6. Private Branch Exchanges—Magneto.
7. House Telephone Systems.
8. Wiring of Subscribers' Premises.

## **GROUP G.**

1. Maintenance of Secondary Cells.
2. Power Plant for Telegraph and Telephone Purposes.
3. Maintenance of Power Plant for Telegraph and Telephone Purposes.
4. Telegraph Battery Power Distribution Boards.

## **GROUP H.**

1. Open Line Construction, Part I.
2. Open Line Construction, Part II.
3. Open Line Maintenance.
4. Underground Construction, Part I—Conduits.
5. Underground Construction, Part II—Cables.
6. Underground Maintenance.
7. Cable Balancing.
8. Power Circuit Guarding.
9. Electrolytic Action on Cable Sheaths, etc.
10. Constants of Conductors used for Telegraph and Telephone Purposes.

## **GROUP I.**

1. Submarine Cables.

## **GROUP K.**

1. Electric Lighting.
2. Lifts.
3. Heating Systems.
4. Pneumatic Tube Systems.
5. Gas and Petrol Engines