

Crown Copyright Reserved

PW—D.22

Post Office Engineering Department

TECHNICAL PAMPHLETS FOR WORKMEN

Subject:

Units, Amplifying

ENGINEER-IN-CHIEF'S OFFICE

July, 1935

LONDON

PRINTED AND PUBLISHED BY HIS MAJESTY'S STATIONERY OFFICE

1935

===== LIST OF =====
Technical Pamphlets for Workmen
=====

GROUP A

1. Magnetism and Electricity.
2. Primary Batteries.
3. Technical Terms.
4. Test Boards.
5. Protective Fittings.
6. Measuring and Testing Instruments.
7. Sensitivity of Apparatus.
8. Standard List of Terms and Definitions used in Telegraphy and Telephony. (*Not on Sale.*)
9. Standard Graphical Symbols for Telegraphy, Telephony and Radio Communication. (*Not on Sale.*)

GROUP B

1. Elementary Principles of Telegraphy and Systems up to Morse Duplex.
2. Telegraph Concentrators.
3. Wheatstone System. Morse Keyboard Perforators.
4. Quadruplex, Quadruplex Repeated Circuits and Telegraph Repeaters, Simplex and Duplex.
5. Hughes Type-printing Telegraph.
6. Baudot Multiplex Type-printing System.
7. Western Electric Duplex Multiplex. Murray Duplex Multiplex. Siemens and Halske Automatic Type-printing System.
8. Fire Alarm Systems.

GROUP C

1. Wireless Transmission and Reception.
2. Interference with Reception of Broadcasting.

GROUP D

1. Elementary Principles of Telephony.
2. Telephone Transmission. "Loading." Telephone Repeaters and Thermionic Valves.
3. Principles of Telephone Exchange Signalling.
4. Magneto Exchanges—Non-Multiple Type.
5. Magneto Exchanges—Multiple Type.
6. C.B.S. No. 1 Exchanges—Non-Multiple Type.
7. C.B.S. Exchanges—Multiple Type.
8. C.B. Exchanges—No. 9 Type.
9. C.B. Exchanges—No. 10 Type.
10. C.B. Exchanges—No. 12 Type.
11. C.B. Exchanges—22 Volts.
12. C.B. Exchanges—40 Volts.
13. Trunk Telephone Exchanges.
14. Maintenance of Manual Telephone Exchanges.
15. Telephone Testing Equipment.
16. Routine Testing for Manual Telephone Exchanges.
17. Internal Cabling and Wiring.

[Continued on page iii of Cover.]

CORRECTION SLIP TABLE.

The month and year of issue is printed at the end of each amendment in the Correction Slips, and the number of the slip in which any particular amendment is issued can, therefore, be traced from the date. In the case of short corrections made in manuscript, the date of issue of the slip should be noted against the correction.

The Summary portions of the Correction Slips should be completed and affixed below in numerical order.

CORRECTION SLIP TABLE (contd.)

The month and year of issue is printed at the end of each amendment in the Correction Slips, and the number of the slip in which any particular amendment is issued can, therefore, be traced from the date. In the case of short corrections made in manuscript, the date of issue of the slip should be noted against the correction.

The Summary portions of the Correction Slips should be completed and affixed below in numerical order.

UNITS, AMPLIFYING

TABLE OF CONTENTS

GENERAL	Page
The Valve	5
The Transformer	5
The Potentiometer	5
UNIT, AMPLIFYING (MAINS UNIT)	
Grid bias	8
Mains Hum	10
Gain Adjustment	11
Mounting and other details	11
POWER PLANT	
H.T. Supply	15
L.T. Supply	15
Standby Battery	16
Trickle-charging	17
Automatic Change-over	18
Mercury Switches	18
"Mains to Battery" change-over	19
L.T. Regulator	22
Alarm	22
Power Failure	23
Battery Charging	26
Motor Generator No. 9	27
Starter	29
UNIT, AMPLIFYING (BATTERY UNIT)	
Description	31
PREPARING TO SET-UP A CIRCUIT	
Attenuation	32
The Decibel	33
Levels and Transmission loss	33
Unit, Terminating	36
Terminal Amplifier	37
Tester No. 109	38
SETTING-UP A CIRCUIT	
Stability Tests	47
Residual Mains Hum (listening tests)	47
BALANCES	
Description	48

UNITS, AMPLIFYING

GENERAL

Trunk telephone circuits were formerly obtained by means of heavy copper wires on an overhead line. About 1920, with the introduction of the "valve repeater," it became possible to use small gauge wires in underground cable for long-distance circuits, and since it was very desirable that there should be little risk of breakdown on important trunk circuits, the "repeaters" were manufactured to a very strict specification. Almost every possible cause of trouble was safeguarded, the "repeaters" were housed in special buildings and a trained staff arranged for maintenance. In 1930, it was decided to develop light gauge cable for short trunks and junctions, so a cheaper form of "repeater" was designed, capable of being housed in a telephone exchange. The result of the investigation is the present-day amplifier, and these notes are intended to explain how the amplifier has been built up, and how it works.

The explanations have been framed in a manner which it is thought will prove interesting and helpful to all officers whose duties may include the maintenance of amplifier circuits.

The Valve.—An amplifier consists essentially of a valve. Now that most folk own a wireless set, the valve is well known, and it is also known that if the filament is heated by means of a current from a battery, a high-tension battery is connected to the anode (plate) and an alternating voltage in the form of speech currents is applied to the grid of the valve, an increase in the volume of speech is obtained if suitable instruments are inserted in the anode circuit. This is called amplification, or in telephone language, "gain." A valve is a one-way device, and the direction of transmission is from the grid to the anode; the "anode to grid" path is practically equal to a disconnexion.

The Transformer.—For many reasons, it is not possible to join a valve directly into a telephone line, so a transformer called an "input transformer" is placed between the line and the grid of the valve. This transformer has many more turns on the secondary or grid winding than on the primary or line winding, and it therefore "steps up" the line voltage to the grid. On the other side of the valve, an "output transformer" is connected between the anode (plate) and the line. This transformer is a step-down transformer, i.e., it has less turns on the secondary or line side than it has on the primary or anode side.

The Potentiometer.—Another important part of the amplifying arrangement is the potentiometer, for without a potentiometer an amplifier will always give a steady gain.

But the amount of gain required varies with different types of circuit, so a tapped resistance (usually 600 ohms) is joined across the incoming line, and the primary winding of the input transformer can then be joined across either part or all of this resistance. To alter the gain of an amplifier, it is only necessary therefore to alter the amount of the resistance across which the transformer is tapped. This resistance is called a potentiometer. It enables a proportion of the total voltage drop to be tapped off. The arrangement is shown in Fig. 1.

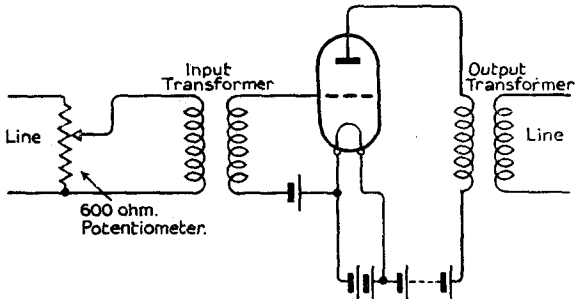

Fig. 1.

It will be noticed that this arrangement passes speech only in one direction, from the input to the output and therefore is only half an amplifier. Before a full amplifier is considered, there is one other part of it which should be specially mentioned. In Fig. 1 the amplified speech from the valve passes from the filament through the high-tension battery and the output transformer to the anode, and back to the filament, and as the same high tension battery is used for all amplifiers on a bay, it is important to prevent speech currents from passing through the high-tension battery, and this is done by means of a by-pass arrangement shown in Fig. 2.

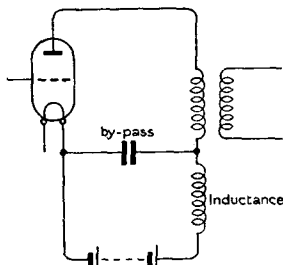

Fig. 2.

The by-pass condenser offers an easy path for the speech current and, to assist in preventing the speech current passing through the battery, an inductance or choke is inserted in series with the battery. The speech currents, therefore, pass through the condenser instead of through the battery. The inductance has another function because use is made of it to provide an alarm. When a valve is working, i.e., when the batteries are connected, there is a direct current called "anode current" flowing from the high-tension battery through the inductance and output transformer to the anode and filament, back to the battery. If either the high-tension or the filament battery fails, the anode current will cease, and the valve will not amplify. The inductance is made in the form of a relay which normally, is held by the anode current flowing through it. If the current should stop, the relay will fall back and operate an alarm circuit.

UNIT, AMPLIFYING No. 6 (MAINS UNIT)

The amplifier shown in Fig. 3, will now be considered. It is known as a "No. 6 through amplifier." In the diagram, current rate book descriptions of valves, transformers, etc., are given. In this pamphlet, 4-wire circuits only will be dealt with, and it will be seen that at a "through" or intermediate station, the amplifying arrangement is extremely simple. A terminal amplifier is slightly more complicated, and will be dealt with in detail later.

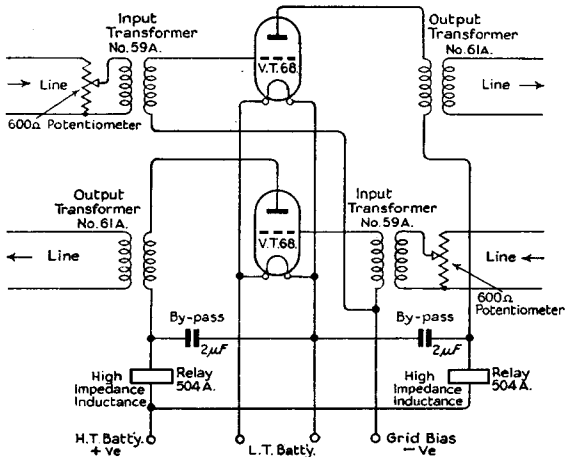

Fig. 3.

So far, only batteries for the supply of power to a valve have been referred to. Actually, as amplifiers are often required in villages and small towns, it is not desirable to use batteries except as a "standby," so the power arrangements for amplifiers usually utilize a public mains supply. For the high tension supply the mains voltage is stepped down by means of a power transformer and rectified into direct current, utilizing a metal rectifier. For the filament current, however, it is not necessary to rectify the alternating current, as all that is needed is a means of heating the filament, but as will be seen later, certain precautions must be taken. The mains supply for the filaments is stepped down to approximately 4 volts, and this "raw A.C." as it is often called, is applied directly to the filaments. The arrangement shown in Fig. 4 can now be considered.

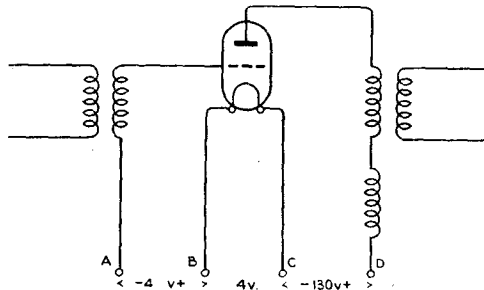

Fig. 4.

First, 4 volts, either A.C. or D.C., is required between terminals B and C to heat the filament. Second, 130 volts direct current is required between terminals C and D with positive pole to D, for the supply of high-tension voltage to the anode. Third, 4.0 volts direct current is necessary between terminals A and B, positive to B, for grid bias.

Grid bias is necessary to enable the valve to amplify without distortion.

Now it does not matter how the grid-bias voltage is obtained. Three dry cells could be used, but that would be a waste of space and material, for there is an easier way of arranging matters. All that is necessary is to insert a resistance in series with the high-tension battery and by means of a drop in voltage, due to the anode current flowing through the resistance, what is commonly called "free" grid bias is obtained.

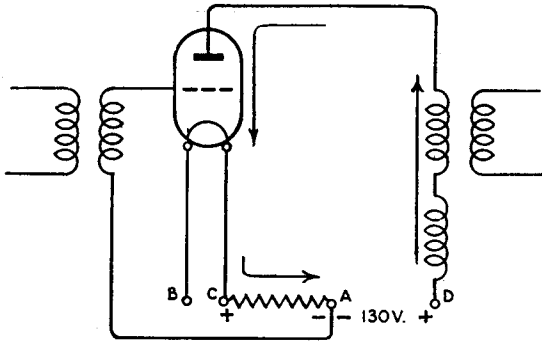

Fig. 5.

In Fig. 5, the direction of the anode current is shown by means of arrows and it will be noticed that it flows from the high-tension positive through the inductance (relay), output transformer, anode, filament and grid-bias resistance. As the current flows in the direction C to A, C is positive and A is negative. If point A is connected through the input transformer winding to the grid, as shown in the figure, a negative grid-bias is applied, and once the value of the anode current is known for a particular type of valve, the value of the resistance can be fixed to give the correct amount of negative bias.

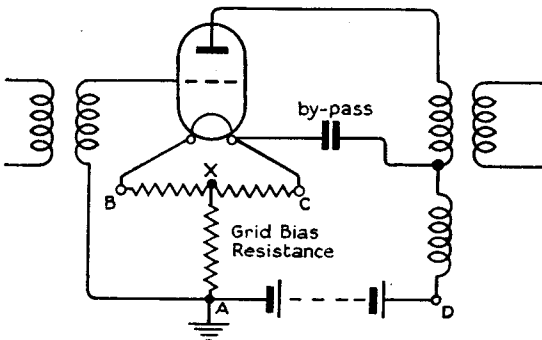

Fig. 6.

Actually, instead of connecting the positive end of the grid-bias resistance to the side of the valve filament as shown in Fig. 5, it would be better to connect it to the middle point of the filament, because then the anode current would flow

equally through the whole of the filament. Unfortunately, it is not possible to get at the middle of the filament, but if a resistance is connected across the filament and then the grid-bias is connected to the point shown by the letter X in Fig. 6, an arrangement is obtained which will secure an equal flow of current through the filament. Since, however, X is 2 volts positive relative to B, the grid-bias voltage between X and A must be 6.0 volts to produce 4.0 volts negative between B and A.

Mains Hum.—The question of mains hum can now be dealt with, i.e., the description applied to the noise often introduced into a broadcast wireless receiver when power is taken from alternating-current mains. Now alternating current applied to the filament causes the voltage at, say, terminal C, Fig. 6, to be first positive and then negative at the frequency of the mains supply, probably 50 cycles a second. This alternating current has a path through the by-pass condenser and the output transformer, and so by induction to the outgoing line. This is undesirable, because the subscriber would be irritated by a continual droning noise. The trouble is overcome in a very simple way.

It has been stated that terminal C of the filament, Fig. 6, is first positive, then negative, and it follows that the other end of the filament, B, is first negative and then positive, so if the grid-bias resistance is connected to B instead of to X, Fig. 6, the alternating voltage, as well as the grid-bias direct voltage produced by the anode current, will be passed to the grid circuit. Therefore, the voltage produced by the alternating current in the grid will be of opposite sign to the alternating current voltage at C end of the filament, and as the grid voltage is reproduced in the anode circuit, it will be seen that the alternating current in the "grid-anode" circuit is in the opposite direction through the output transformer to the alternating "anode-filament" current through the by-pass condenser. These two currents will tend to cancel out, but only if they are equal will they cancel completely. A valve amplifies, and all valves of any particular type amplify by practically the same amount. A valve No. 6S for example, amplifies nine times, therefore only one-ninth of the amount of mains hum should be applied into the grid circuit, so that when it is amplified and passed via the anode and the output transformer, it will be equal to the mains hum passing in the direction—filament, by-pass condenser, output transformer. This is effected by the arrangement shown in Fig. 7.

The resistance placed across the filament is 3.6 ohms. The middle point would be 1.8 ohms. To obtain one-ninth of the voltage drop between B and the centre point of B-C, we

reduce 1.8 by one-ninth, i.e., 0.2 ohms, and place the grid-bias resistance 1.6 ohms from B, and 2 ohms from C. If other types of valves are used or if new types are introduced these values may be altered slightly to meet the new conditions. From this explanation it will be seen how important it is to have each of the resistances connected to its proper side of the filament. In actual practice, individual valves of the same type may vary just a little, and since it is not possible to vary the resistances to suit each individual valve, there will probably still be a little hum passing through the output transformer into the line. For the moment this does not matter as long as it is remembered that there may be a little hum in the line, and it will be explained later how steps are taken to reduce it even further.

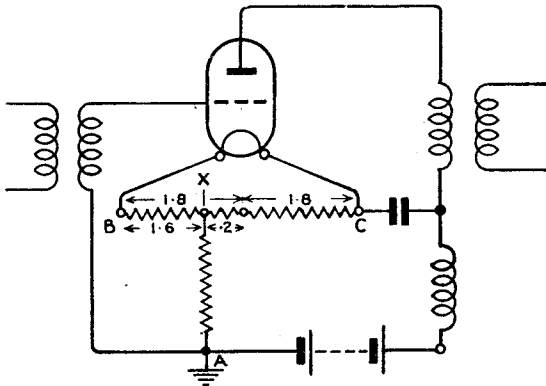

Fig. 7.

Gain Adjustment.—Earlier on, it was explained that the gain of an amplifier could be altered by varying the resistance of the potentiometer across which the input transformer is tapped. The variation may not always be sufficient, so the grid winding of the input transformer is also tapped. If, therefore, a large enough reduction in gain cannot be obtained by means of the potentiometer tap 1, then by using the tap on the grid winding of the transformer, a further reduction can be arranged.

The foregoing explanation is complete as far as amplification is concerned, but the associated apparatus needs further explanation.

Mounting and Other Details.—Plate No. 1 shows the front view of a Unit, Amplifying No. 6, and Plate No. 2, the back view. Amplifiers are supplied mounted on bays, fitted with

doors at the front and the back to keep out the dust. They are built in units of 10, 15 and 20 to the bay. Line transformers are mounted at the top, on both sides of the bay. These transformers have not been mentioned so far. They are inserted in the line in front of the potentiometer for the purpose of matching the line and amplifier impedances. They also facilitate the design of signalling circuits and, by the insertion of condensers in the office side winding, reduce low-frequency noise and mains hum. In coil-loaded cable circuits the impedance is determined mainly by the loading-coil inductance and coil spacing and the approximate impedances for various combinations of inductance and spacing are given in TE140, while the correct type of line transformer can be found by consulting E.I. TRANSMISSION Telephone R.3002. Lower down is the fuse panel accommodating three rows of fuses. The top row consists of high-tension fuses, one for each amplifier, i.e., one for two valves. The 130-volt positive lead is connected to a bus-bar, and from the other side of the fuses separate wires are led to the respective amplifiers. The second and third rows are the low-tension fuse mountings, and the two low-tension leads are connected to two bus-bars. One bus-bar has low-tension fuses fitted, one fuse for each amplifier, but they are inserted on one side only of each amplifier filament circuit. The other bus-bar is fitted with dummy fuses consisting of copper tubes, and leads from these go to the other side of each amplifier filament circuit. It is obvious that a fuse in each leg of the filament circuit is not necessary for safety purposes, but it is convenient to be able to disconnect both filament leads for testing purposes.

The filaments of all the amplifiers are served from the same low-tension supply, i.e., all the filaments are joined together in parallel. As the resistances 1.6 and 2 ohms are placed across the filament circuit to enable the grid-bias resistance to be correctly placed, there is no reason for more than one 1.6-ohm resistance and one 2-ohm resistance for all valves on a bay, so these two resistances are placed across the filament bus-bars, in lieu of separate resistances across each pair of valves. One grid bias, therefore, serves for the whole of one bay of amplifiers. But the anode currents of all the amplifiers on the bay will now flow through the grid-bias resistance, so that less resistance will be required to give the correct voltage at its ends. For a single amplifier, 330 ohms is required, and for 20 amplifiers only 16.5 ohms is necessary. A tapped grid-bias resistance is therefore provided, and this can be altered to suit the number of amplifiers actually in use on the bay. There is no need to work out the resistance necessary for any particular number of amplifiers, because the tappings on

the resistance are led out to tags and the number of working units served by each tag is marked. If there are four units working, then the grid-bias lead is soldered to tag 4, and when an increase to say twelve working units is necessary the lead is soldered to tag 12.

It has already been stated that the anode current flowing in all the valves also flows through the grid-bias resistance, and when any amplifier is carrying speech there is a small amount of alternating speech current in the grid-bias resistance. If speech current flows in the grid-bias resistance, it is liable to enter the grid circuits of all the other valves, and this is prevented in the following manner.

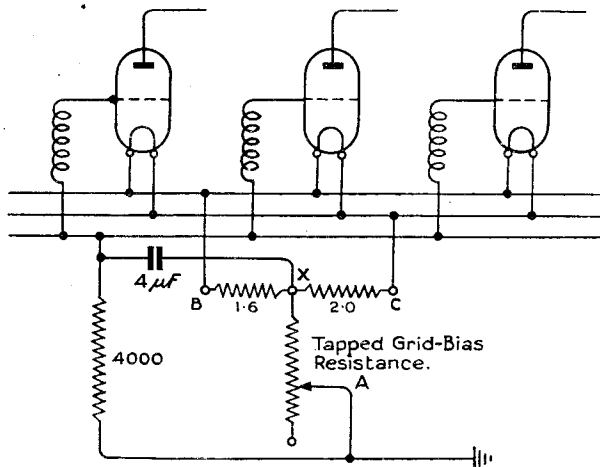

Fig. 8.

Between the earth connexion of the grid-bias resistance and the input transformers (see Fig. 8) a resistance of 4,000 ohms is inserted, and at the input transformer end, a 4 μF condenser is connected to the point X of the grid-bias resistance. The 4,000-ohm resistance reduces the alternating speech current and finally a low impedance path is available through the condenser back to the grid-bias resistance, thus preventing speech current from circulating to the other grid circuits. The 4,000-ohm resistance and the 4 μF condenser are mounted at the back of the Test panel provided on each bay. It should be noted that the earth connexion of the grid bias is joined to the high tension negative through a common earth connexion.

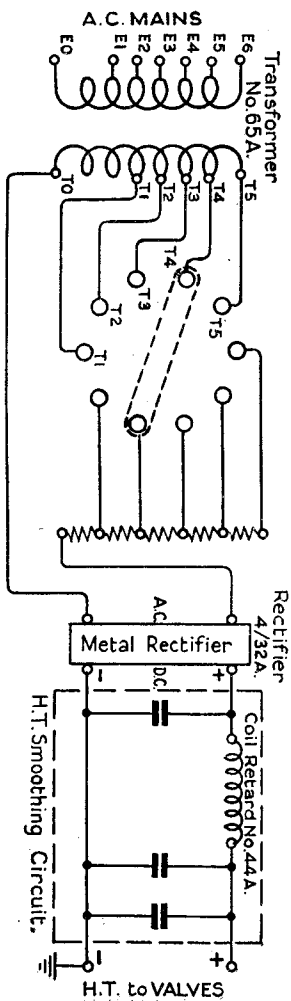

Fig. 9.

POWER PLANT

Power Board Arrangements.—First, it is assumed that the power supply is alternating current. (If the supply is direct current, a motor generator is supplied to convert it to alternating current. This is a question of policy, as before very long probably all public supplies will be alternating current).

H.T. Supply.—130 volts direct current is required for the high-tension supply to the valves, and the public mains supply may be any value between 200 and 250 volts alternating current. So first, the mains voltage is transformed as shown in Fig. 9.

The mains transformer has tappings on both windings, and the mains supply is connected to the side marked E0, E1, E2, E3, E4, E5 and E6. If the voltage of the mains is 200, the supply is connected to terminals E0 and E1. If the voltage is 210, then connexions E0 and E2 are used, and so on using E0 and E6 for 250-volt mains. The tappings on the secondary side of the transformers are marked T0, T1, T2, T3, T4 and T5, and the tapping to be used will depend upon the number of amplifiers intended to be worked. Tappings T1 to T5 are brought out through resistances to a panel on the back of the power board, and alterations can be made by means of a copper strap. From the transformer, the power leads go to a large metal rectifier which converts the alternating current into direct current, but this current is not quite "clean" enough, because it still contains a slight ripple of alternating current, and to remove the ripple the rectified current flows through a smoothing circuit which produces a current practically as smooth as a battery current. The smoothing circuit consists of three condensers and an inductance, and is shown in Fig. 9.

L.T. Supply.—In addition to the high-tension voltage, 4 volts alternating current is required for the filament circuits, and this is obtained in the following manner. First, the current from the main supply passes through a filter, as shown in Fig. 10.

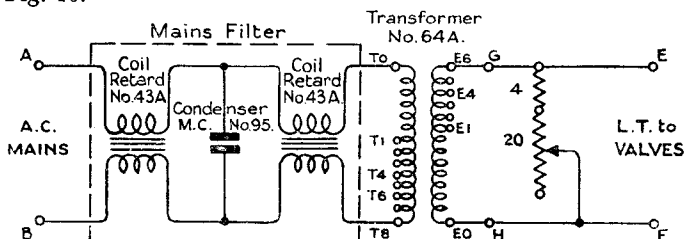

Fig. 10.

This filter is made up of two inductances and one condenser and removes any noise which has a note higher than the normal 50 cycle hum. The filter seems to be a simple piece of apparatus but it can cause difficulty with the voltage if care is not taken with the power load. A transformer is placed immediately after the filter to step down the voltage to four volts, and it has been found that if the transformer is tapped in a certain way, it will take care of all possible troubles due to the load on the filter. In this case, it will be noticed that terminals E0 to E6 are on the secondary winding and that terminals T0 to T8 are on the primary winding. The tappings to meet various main voltages are made on the secondary side, but they are still labelled with the letter "E". Therefore, E0 and E1 would be used if the mains voltage is 200 and E0 and E6 if 250 volts, although, as will be seen, the leads go to the valve filaments and not to the mains supply. The leads from the mains supply pass through the filter and are joined one to T0 and the other to one of the T1 to T8 terminals, depending on the number of amplifiers intended to be worked.

This explanation has been given because of the difference between Figs. 9 and 10. In Fig. 9 the connexions lettered E are connected to the main supply, whereas in Fig. 10, the letters E are connected to the filament supply to the valves, but all that is required is to adjust the wires which are already either on the E or the T side. In case it is found impossible with existing tappings to obtain the exact voltage required, there is a 24-ohm resistance connected across the low-tension valve supply, and this can be varied from 24 to 4 ohms. If only a few amplifiers are working, and say tap T4 is in use, variations of the 24-ohm resistance will enable the correct voltage to be obtained, but if all or nearly all the units are working, then variation of the resistance will not have very much effect, but in that case, it will be found quite easy to obtain the correct voltage from one or other of the tappings.

Standby Battery Arrangements.—Although so far batteries have been dispensed with, it is not possible to do without them altogether. Occasionally a mains supply fails, and this must be provided for, as the shutting down of many telephone circuits is a serious matter.

It is necessary, therefore, to install small standby batteries for use if and when the mains supply fails. The high-tension battery is 68 cells, giving 136 volts approximately, and the low-tension battery is 3 cells, giving 6 volts approximately. The cells are not large, and will last for only five hours if all the amplifiers in the station are working. It is very necessary therefore, that the standby batteries shall always be kept

fully charged, so that when wanted, they are in good condition. In fact, they are kept permanently trickle-charged and Fig. 11 shows the arrangement for the H.T. battery.

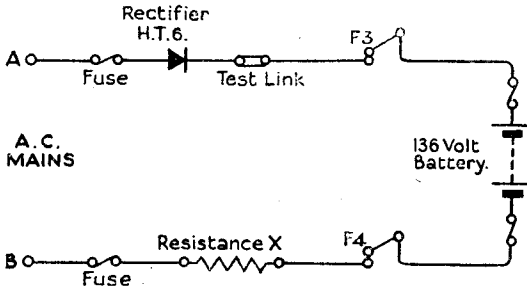

Fig. 11.

Trickle-Charging.—The alternating current mains supply is rectified into direct current by means of a small rectifier and a resistance, X, is in series to ensure the correct charging current. A test link is provided in the circuit so that the charging current may be checked, and this should be done regularly in order to see that the fuses are intact and that the batteries are being charged. To do this, the link is removed and a Detector No. 2 or 4 put in its place. The link is mounted on the front of the power panel.

Contacts F3 and F4 are part of a mercury switch which will be explained later. The fuses are mounted on a distribution board which also carries fuses in each lead of the mains supply for seven other parts of the power board.

From A and B shown in Fig. 11, two wires are provided for trickle-charging the low tension battery as shown in Fig. 12.

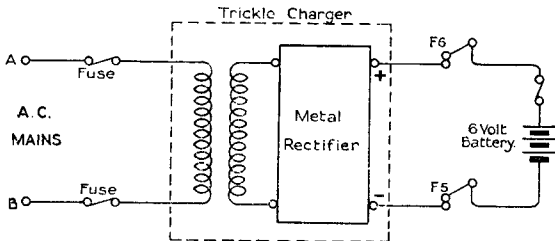

Fig. 12.

The arrangements are similar to those for the high-tension trickle-charging, but there is a transformer to step down the mains supply voltage. On this transformer there is a clamping

nut, and by loosening it the magnetic flux in the transformer windings can be increased or reduced by movement of a pole piece, thus providing an adjustment of the charging current.

Automatic Change-over arrangements.—Amplifiers may not always be constantly under attention, and arrangements must be made for the standby batteries to be switched over to the amplifiers automatically, as and when the mains supply fails from any cause.

When all the amplifiers on a bay are working, the current taken by the valve filaments may be as much as 20 amperes, and it is obvious that if this current is suddenly broken by say, a relay, there will be a big spark at the relay contact. This is the reason why a special form of switch known as a mercury switch is used. Fig 13.

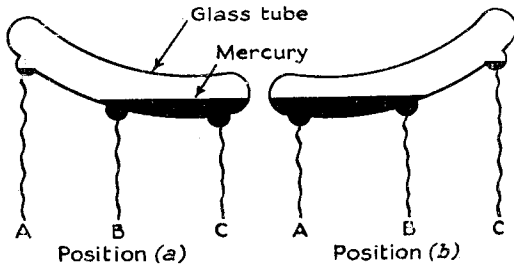

Fig 13.

Mercury Switches.—The switch is formed of curved glass tubes with wires sealed inside the tubes at three small cups or recesses on the underside. Each tube is pivoted and can be rocked from side to side by means of a plunger, operated by an electro-magnet.

A small quantity of mercury is placed in the tube before it is sealed, just sufficient to cover two cups only. Assume that a tube is tilted over to the right as in Fig. 13 (a) and then over to the left as in (b). The mercury forms a contact between B and C in (a) and between B and A in (b); in other words, each tube forms a simple two-way switch. The tubes are robust and have been rocked experimentally thousands of times without damage, even when a current of 20 amperes is flowing. Plate 3 is a photograph of one of the mercury switches with the cover removed. Two types are in use, but there is very little difference between them; both are rocked by means of a plunger worked by an electro-magnet.

“Mains to Battery” Change-over.—Returning to Fig. 10 the two terminals marked G and H are connected as shown in Fig. 14, and the voltage between them is 4 volts approximately.

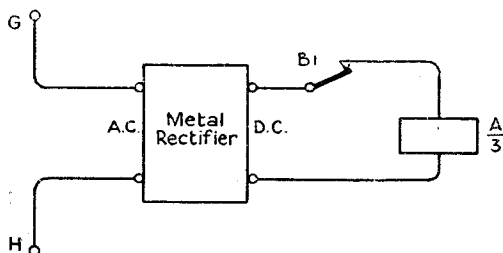

Fig. 14.

The A.C. voltage is rectified and the direct current passes through contact B1, which will be explained later, and then through relay $\frac{A}{3}$. If the mains supply fails, then there will be no voltage across the metal rectifier, no rectified current, and relay $\frac{A}{3}$ will not operate. We have now to arrange that when

this happens the contacts on relay $\frac{A}{3}$ will cause an electromagnet in the mercury switch to rock the tubes in such a way as to change from mains supply to battery supply. It has already been explained that the standby batteries are continuously trickle-charged, so the first thing to be done is to disconnect the trickle-charging arrangements. Secondly, the leads to the valve anodes from the high-tension rectifier must be disconnected, and then reconnected to the high-tension battery. Thirdly, the low-tension leads must first be disconnected from the low-tension transformer and then connected to the low-tension battery. Finally, since all this is done automatically, an alarm must be given so that the officer responsible may know what has happened.

There are two switches, each consisting of six tubes, and the complete arrangement is shown in Fig. 15.

The dotted line down the middle of the diagram is to divide the two switches, for actually they are mounted on separate panels.

Plate No. 4 is a front view of a power panel No. 4 which is the control panel for the whole amplifier station. There is a separate power panel No. 3 for each individual amplifier bay, and a front view of this is given in Plate 5. The switch F is

mounted on panel No. 4 and a separate switch E on each panel No. 3. To simplify the description it will be assumed that there is only one bay of amplifiers and therefore only one switch E. The letters Fa, Fb, Ea and Eb represent the electro-magnets operating the plungers by which the tubes are rocked. When Fa carries current, its plunger rocks the tubes of switch F to the right, and when Fb carries current, the same plunger works the opposite way and rocks the tubes to the left. Similarly, Ea will rock the tubes of the second switch to the right, and Eb to the left. In the figures, the tubes are all shown to the left by full lines, and the dotted lines show the connexions when the tubes are rocked to the right. Whichever way the tubes come to rest, they will stay in that position until again rocked by one or other of the electro-magnets. The three circles shown for each tube represent the three mercury cup contacts. The tubes have been numbered one to six, and the contacts lettered, L, C and R, and mean left, centre and right, for the purpose of the following explanation.

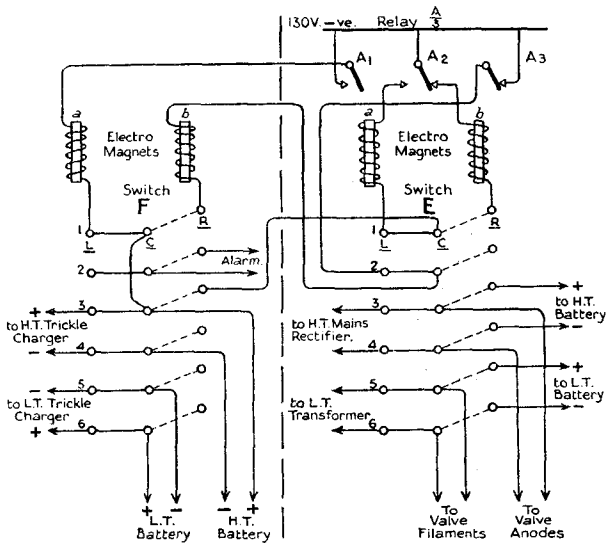

Fig. 15.

It was stated in connexion with Fig. 14 that when mains current is flowing, Relay $\frac{A}{3}$ is operated, and the positions of its three contacts A1, A2 and A3 are as shown in Fig. 15. When

the mains supply fails, the contacts change over. Contact A1 passes 130 volts negative from the battery through electro-magnet Fa, through tube F1, contact L and C, to 130 volts positive. Fa now operates and the plunger rocks switch F to the right. Four things happen immediately. The first and second are that the high-tension and low-tension trickle-charge leads are disconnected from the batteries by means of tubes 3, 4, 5 and 6. The third is that tube 2 makes a circuit for an alarm bell and the fourth that tube 3 has prepared the way for change-over to battery.

A current from 130-volt battery positive passes through tube F3, contacts C and R, through tube E1, contacts C and L, through the electro-magnet Ea and through contact A2 (which changes over with contact A1) back to 130 volts negative. Ea now operates and its plunger rocks switch E over to the left. Tubes 3, 4, 5 and 6 of switch E transfer the valve anodes and filaments from the mains supply to battery supply.

Now assume that the stoppage was only momentary, and that the mains supply is immediately restored. Relay $\frac{A}{3}$ contacts return to normal as shown in Fig. 15 and the current from 130-volt battery negative passes through contact A2, through electro-magnet Eb, through tube E1, R and C, through tube F3, R and C, to 130 volts positive. Electro-magnet Eb operates and rocks switch E to the left position; 130 volts battery negative has a current through contact A3, through tube E2, contacts L and C, through the electro-magnet Fb, through tube F1, contacts R and C, to 130 volts positive. Fb operates, and rocks switch F back to the left, and everything is normal again.

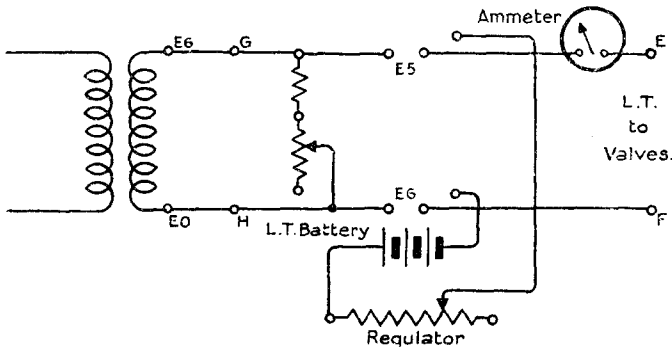

Fig. 16.

It must not be assumed, however, that the mains supply will always be restored quickly. The case where a supply is cut off for, say, an hour or more must be visualized. Imagine the failure to occur some time during an evening when the officer responsible may be at home. If everything works correctly, switches F and E will operate and the supply will be changed from mains to battery.

L.T. Battery Regulator.—When tubes 5 and 6 rock over to the right, the low-tension battery is in series with a regulator, as shown in Fig. 16. The regulator is important and can be seen in Plate 5 on the right-hand side of the power panel. It is a slide resistance worked by means of a small wheel. Since the low-tension battery is normally permanently trickle-charged, its voltage should be high when it is first switched over to the valves, and it is necessary, therefore, to provide a resistance to cut down the voltage in order that the valve filaments do not receive more than 4 volts.

It was assumed that the responsible officer was not in attendance and he could not, therefore, adjust this regulator, so it is important to see that the regulator is always left in a position which will produce the right voltage when the battery is switched in. Once the right position has been found, it should be marked plainly and it will be possible then to see at a glance whether the regulator is in the correct position to meet an emergency change-over.

Alarm.—It will be assumed that the emergency has arisen, and that the batteries have taken the place of the mains supply. The batteries will work satisfactorily for a while, provided the regulator is in its correct position. The alarm bell has been operated by contacts C and R, tube F2. The exchange operator, or whoever is responsible for attending to the alarm, will now give it attention, and will advise the maintenance officer. Usually the operator is provided with a switch which will cut out the alarm bell, and substitute a lamp, but, in any case, the alarm will remain operated until someone attends to it. On the arrival of the maintenance officer at the amplifier station, the first thing to do is to stop the alarm.

It was stated previously that whichever way the tubes rested, they would stay in that position until rocked again by one of the electro-magnets. There is one exception to this, and that is the case of tube F2 which gives the alarm. It is true even in this case that the tube will be rocked to the right if electro-magnet Fa operates, but when Fb operates, tube F2 remains to the right to give the alarm and can be restored only by hand. Referring to Plate 3 it will be seen

that a lever, projects from the switch on the right-hand side through a hole in the cover. To reset tube 2 to the left, and so stop the alarm, this lever should be pushed in.

Power Failure.—If there are no other electric power services in the building, to indicate definitely that the mains supply

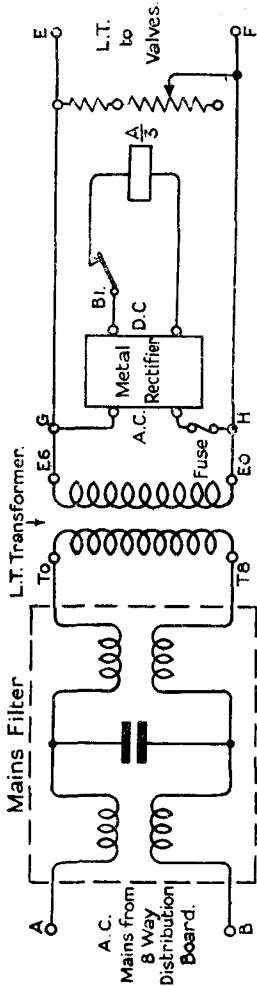

Fig. 17.

has failed, it will be necessary to prove the nature of the fault. This should be done by means of a voltmeter at the mains switch, but it is possible that a suitable type of voltmeter may not always be available. A temporary arrangement would be to use a lampholder and two insulated wires to tap a lamp across the mains side of the main switch. Assuming that the mains supply has failed, enquiries should be made as to whether the breakdown is regarded as serious or not, because if the breakdown is likely to last for some hours, the Sectional Engineer must be advised so that he can consider whether some of the amplifiers should be switched out of service in order to economise the battery power. The only other matter requiring attention is the low-tension battery regulator. The low-tension battery voltage will begin to drop on discharge and the regulator must be altered from time to time to allow for the reduction in the battery voltage. If however the main supply tests O.K. it must be assumed that the fault is somewhere on the power equipment.

First, make sure that the trouble is not a simple failure such as a blown fuse. There are two fuses in the iron-clad mains switch on the front of the power panel, see Plate 4. From that point, wires are led to fuses on an 8-way distribution board (see Plate 4), and thence to the high and low-tension supplies. Referring to Fig. 10, it will be seen that the rectifier which provides current for operating relay $\frac{A}{3}$, is joined across terminals G and H.

Figs. 10 and 12 are combined in Fig. 17, and it will be seen that if the mains supply and fuses are intact up to the 8-way distribution board, relay $\frac{A}{3}$ may fail to operate if one or other of the pieces of apparatus shown in the figure is faulty. Begin by testing the voltage across the secondary of the low-tension transformer and if 5 volts alternating current is obtained, the transformer and mains filter are proved O.K. Next, test the rectifier fuse and finally examine relay $\frac{B}{1}$, to see whether the contact is satisfactory. This relay has not been mentioned previously, although its contact B1 is included in Fig. 14. Relay $\frac{B}{1}$ was omitted from Fig. 9 to avoid complications, so Fig. 9 is reproduced in a simple form with the relay inserted, in Fig. 18.

It will be noticed that relay $\frac{A}{3}$ is placed across the low-tension circuit just before the mercury switches, and it therefore covers all failures of low-tension apparatus, but it does

not cover the apparatus on the high-tension circuit and a failure here is just as serious. At J and K in Fig. 18, the last point in the circuit before the high-tension switches, relay $\frac{B}{1}$ is connected. The relay is operated by the rectified high-tension current, and its contact B1 completes the

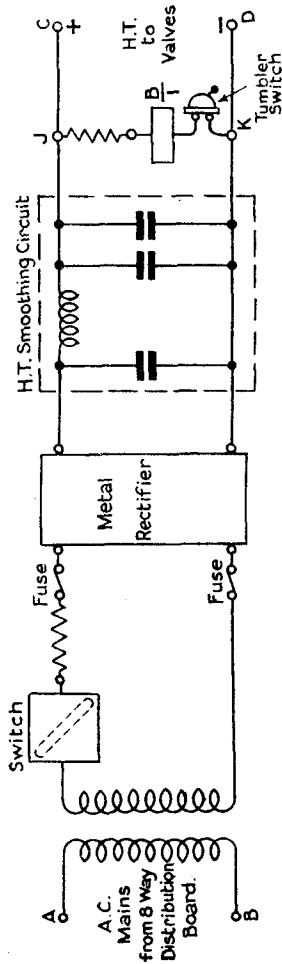

Fig. 18.

circuit for relay $\frac{A}{3}$, see Fig. 17. If now a fault develops on the high-tension apparatus, relay $\frac{B}{1}$ will cease to operate and its contact B1 will break the circuit of relay $\frac{A}{3}$ and the mercury switches will change-over. If the circuit is found to be broken, trouble is indicated somewhere in the high-tension apparatus.

First test the high-tension transformer, then the resistances on the switch shown in Fig. 9, then the two fuses, the metal rectifier and finally the high-tension smoothing circuit. If the fault is found in any of the low-tension or high-tension apparatus, nothing can be done except to report immediately which item has failed. Faults on apparatus, however, are very rare and if the switches change over to battery, it will almost invariably be a mains supply failure or a blown fuse. In Fig. 18, it will be noticed that there is a tumbler switch in series with relay $\frac{B}{1}$. Normally this switch is in

the "on" position to complete the circuit for $\frac{B}{1}$, and if it is switched to "off", contact B1 will break the circuit of $\frac{A}{3}$ and the mercury switches will change over. The tumbler switch is provided as a means of testing that the mercury switches operate correctly, and for the temporary use of the secondary batteries. On Plate 4 two voltmeters are shown. One voltmeter (0-10 volts) is for the low-tension supply, and the other (0-200 volts) for the high tension. Each voltmeter has a switch associated, so that it can be connected across the battery or across the bus-bar of any bay of amplifiers.

On Plate 5 will be seen an ammeter which is connected in one of the low-tension leads to the valve filaments, and since it is in circuit after the mercury switch (Fig. 16), it measures the current, whether the valve filaments are being fed from the mains supply or the battery. Plate 6 shows a rear view of Power Panel No. 4, and Plate 7 shows a rear view of Power Panel No. 3.

Battery Charging.—When the mains have failed and are again restored, it is important to remember that the batteries must be recharged, because the trickle-charge makes good only the small loss which is always taking place. In order to obtain the correct charging current after the batteries have been in use for some time, charging plant is installed and its type is dependent upon the power supplies which are available.

If the mains are direct current, the high-tension battery will be charged through a resistance, and the low-tension battery by a dynamotor. If the mains are alternating current, both batteries will probably be charged by means of a rectifier, but battery charging is not an item special to amplifiers.

Motor-Generator No. 9.—So far it has been assumed that the mains supply is alternating current but, occasionally, direct current must be catered for. It is anticipated that sooner or later all public supplies in this country will be alternating current, so it has been arranged to supply a Motor-Generator No. 9 for direct-current mains supply, and to keep uniform the remainder of the power equipment. The motor-generator converts the direct current to 230 volts alternating current, 50 cycles. It consists of a direct-current motor—designed to meet the voltage of the mains supply, coupled to a 50-cycle alternator with separate exciter.

There is also a double-pole mains switch and separate stop-start buttons. The stop button is supplied for quick operation, as it is easier to push a button to stop the machine than to turn a switch. The reason for the start button is not so apparent. If an alternating current mains supply fails, the change to battery is automatic, and when the mains are restored, the change back is also automatic. With direct-current mains, however, it is not possible for the *change-back* to be completely automatic because when the motor first starts up, the voltage of the alternator is above normal, and before the supply to the valves is switched in, the alternator must run at a steady voltage. This is the reason for the start button. If, therefore, a direct-current mains supply should fail, the following precautions must be taken when the supply is restored.

First, open the mains switch on the amplifier power panel. Next push the start button and, when the motor is running at constant speed, say after an interval of two minutes, close the mains switch on the amplifier power panel.

Fig. 19 shows the arrangement of motor-generator No. 9. When the start button is pushed in, the mains voltage is applied to the motor through a resistance so that the motor will start slowly, and then as it speeds up, the automatic starter cuts out the resistance and the motor gains full speed. There are two regulators, one in the field of the motor and the other in the field of the alternator. The motor field regulator is to enable the speed of the motor to be varied and the speed should be adjusted to 1,000 revolutions per minute. The speed is measured by an instrument called a "Counter Speed, No. 1." The alternator field regulator varies the output of the alternator and this should be adjusted to 230 volts.

In addition, there may be a compensator in either the motor field or the alternator field, to maintain the alternator output at a constant voltage when otherwise it would vary because

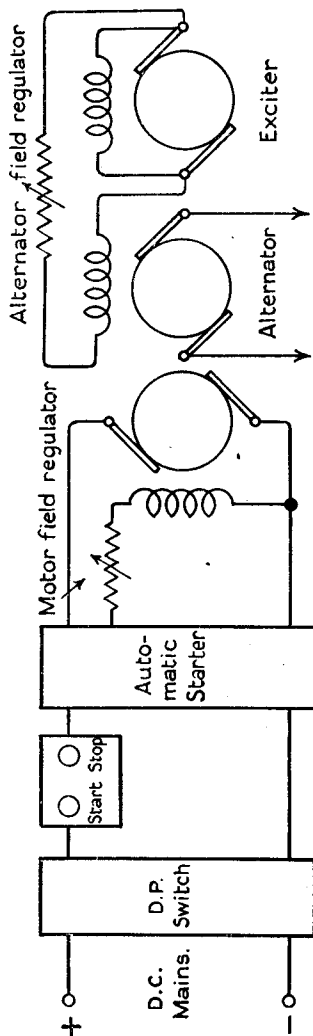

Fig 19.

of variation in the mains supply. The compensator may be either a wire resistance, which varies with the current flowing and usually runs at a dull red heat, or it may be a barretter tube filled with gas. The resistance should not be mounted in a draughty place, particularly draughts created by the opening of doors.

In some machines, however, the compensation is part of the alternator design, and no external compensator is necessary.

Starter.—The operation of the automatic starter is interesting. Here again, different manufacturers have different ways of doing the same thing, but a diagram is always supplied with each type of starter and, if Fig. 20 is examined, it will enable the general principles to be understood.

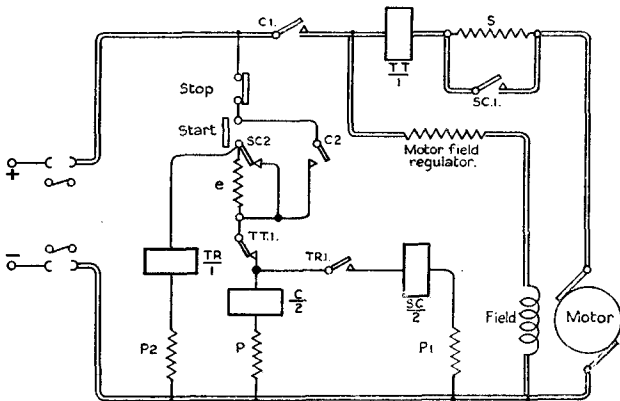

Fig. 20.

Fig. 20 shows the arrangement of the Electric Construction Company's starter. The main circuit is shown by double lines. The positive terminal of the direct-current mains is connected through one side of a double-pole switch to contact **C1**. When **C1** makes, the circuit is extended through relay $\frac{TT}{1}$, through resistance **S**, to the motor armature and back to the negative terminal of the mains. Contact **C1** also places the mains voltage through the regulator and motor field. To start the motor, relay $\frac{C}{2}$ must be operated to close contact **C1**.

The current from the mains positive passes through the stop-button contacts, to one contact of the start button. If the start button is pushed in, the path of the current is through

contact SC2, which short-circuits resistance e, to contact TT1, through relay $\frac{C}{2}$ and resistance P, to the mains negative.

Relay $\frac{C}{2}$ operates, C1 closes, and the mains current passes through the regulator and motor field, and to the motor armature through resistance S. The motor starts up and commences to gather speed. The start button is now released, but C2 has already made contact across the start button contacts, so the release of the button does not break the circuit through $\frac{C}{2}$.

When the start button was pushed in, the positive voltage was also applied to relay $\frac{TR}{1}$ and through resistance P2 to mains negative. Relay $\frac{TR}{1}$ is a slow-acting relay and is adjusted so that it does not operate until the motor has attained a fair speed.

When relay $\frac{TR}{1}$ operates, it passes a positive voltage through contact TR1 to relay $\frac{SC}{2}$ and thence through resistance P1 to negative. $\frac{SC}{2}$ operates, contact SC1 short-circuits resistance S and the motor now attains full speed. Contact SC2 is broken and removes the short circuit from resistance e, which is now in series with relay $\frac{TR}{1}$. This reduces the current through relay $\frac{TR}{1}$ because, once it has been operated, the relay does not require a heavy current to hold. Relay $\frac{TT}{1}$ is an "overload" relay. If the motor is loaded too heavily, the current taken from the mains increases to a value sufficient to operate relay $\frac{TT}{1}$. The contact TT1 then breaks the circuit to relay $\frac{C}{2}$ and the supply is cut off by contact C1. It will be noticed that pushing in the stop button will also cut off relay $\frac{C}{2}$.

The starter supplied by Messrs. Haslam & Newton works in a similar fashion except that instead of relays $\frac{TR}{1}$, $\frac{C}{2}$ and $\frac{SC}{2}$, a

dash-pot relay is provided. The relay has a plunger which works in a pot filled with oil, and as its action is slow, it cuts out resistance as the motor speeds up. A diagram is supplied by the makers with the set, and it should not be difficult to follow the working.

UNIT, AMPLIFYING, No. 9 (BATTERY UNIT)

The general case of amplifiers with mains power supply has now been considered. In towns where there is a repeater station, however, it may be convenient to install amplifiers in the repeater station building. All main repeater stations have large 130-volt high-tension and 24-volt low-tension batteries, and it is unnecessary to install special power equipment for amplifiers. Units, Amplifying, No. 9, therefore, have been designed to replace Units, Amplifying, No. 6, in such circumstances.

The chief difference between a Unit No. 9 and a Unit No. 6 is that No. 9 takes V.T. 75 valves, battery-operated, and this valve does not give quite as much gain as valve V.T. 68.

To utilize the repeater station 24-volt low-tension battery, two valves V.T. 75 are run in series, taking together 8 volts, and since the rest of the battery voltage must be taken up by resistance, part of the resistance for the grid-bias arrangement is utilized as shown in Fig. 21.

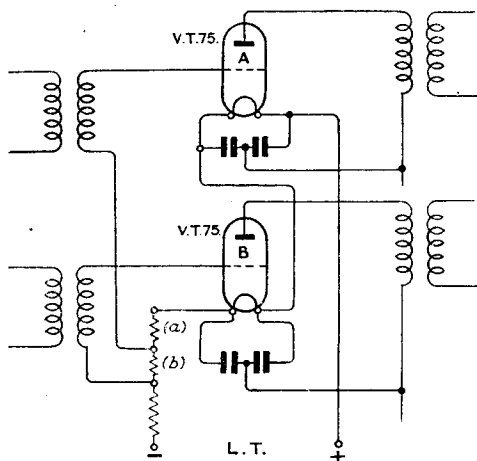

Fig. 21.

The positive of the low-tension battery is connected to the filament of valve A, which is in series with the filament of valve B. From the filament of valve B the circuit is through

two resistances (a) and (b) and then through a further resistance to the negative battery terminal. Resistance (a) is the grid-bias resistance for valve A, and resistance (b) for valve B. A third resistance absorbs the surplus low-tension volts. The only other difference between the equipments No. 6 and No. 9 is that in the case of No. 9, instead of a by-pass condenser on one side of the filament, there are two condensers across the filament circuit and the centre point is connected to the output transformer.

PREPARING TO SET-UP A CIRCUIT

It is now possible to explain the terminal amplifying arrangements, and this can best be done by considering the factors involved in setting-up a circuit.

First, assume that a cable has been laid between two towns, named say, X and Y, and it is required to obtain a circuit in this cable with a specified transmission loss.

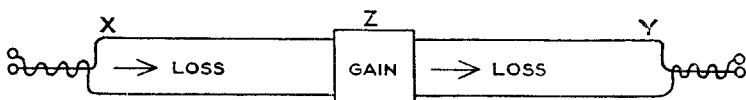

Fig. 22.

Fig. 22 shows one pair of wires in the cable between X and Y. When a telephone is spoken into, the sound is converted into a form of alternating current and this means that an electrical voltage, of speech frequency, has been applied to the line at X. The speech currents in the circuit will gradually weaken along the line towards Y. This is known as "attenuation," but in ordinary telephone language is usually termed "line loss."

If an amplifier is inserted in the line, say at the middle point, Z, and if it is arranged that the amplifier gives a gain equal to the loss in the line between X and Z, the speech currents leaving Z will be of the same value as when they left X, and the reception at Y will be considerably improved.

In order to arrange that the gain at Z shall be equal to the line loss between X and Z, some means of expressing losses and gains must be arranged and a means of measuring them must be available. It is necessary first to select a standard of comparison. The speech power in a telephone circuit is of the order of 1 milliwatt, and this power has been adopted as the standard power for testing purposes. It is necessary also to specify the testing frequency, and this is generally 800 periods per second.

The average impedance of a telephone line and of the apparatus connected thereto is of the order of 600 ohms, and, to obtain 1 milliwatt in a circuit of 600 ohms, it is necessary to apply 0.78 volts.

It is easier, however, to measure voltage than power, so in practice it is usual to measure voltages. The point on a line of 600 ohms impedance at which the voltage is 0.78 is said to be at zero level, and the level at another point can be expressed by saying that it is a certain amount above or below zero.

A high-resistance voltmeter is used in testing and is specially calibrated. When the voltage is 0.78 the pointer indicates zero level, and the levels above or below this are indicated in decibels. The term decibel expresses a ratio, and the full description of its derivation and use will be found in E.I. TRANSMISSION, General, A1001. It will suffice to say here that if a reading of, say, -6 decibels is obtained, the instrument has really measured a voltage of 0.39. Now $\frac{0.78}{0.39} = 2$, and the logarithm of 2 is 0.3. As the measurement is one of electrical pressure and not power, the result must be multiplied by 20 instead of 10, and the answer is 6 decibels. The instrument is marked or calibrated on this basis.

If the level at a point in a telephone line is indicated as +10 db. as for example, at the output of an amplifier, while the input of the next amplifier in the line indicates a level of -20 db., the section of line concerned is said to have a transmission loss of 30 db. It is important to grasp the distinction between level and transmission loss (see page 42). It is also very important to remember that if the instrument is to indicate correctly, then the testing power at the sending end must be adjusted exactly to 1 milliwatt at the frequency specified for the test.

The simple relation between Resistance R ohms Electrical Pressure E volts, and Current I amperes, known as Ohm's Law, will be well understood, viz. :—

$$I = \frac{E}{R}$$

In direct-current measurements, the effect of capacity and/or inductance in a circuit is momentary, and is therefore disregarded, because the resistance or opposition to the flow of current is calculated in the steady-current condition. In alternating current, however, as the name implies, the current is never steady, it is always growing or declining, so that any

capacity and/or inductance in a circuit will make its presence felt continuously. We must account for these effects when dealing with telephone currents due to speech, so the reactance due to capacity or inductance or to both, must be linked with ohmic resistance, and this is done under the term "impedance". Even if a circuit has no appreciable capacity or inductance, we still speak of impedance to denote alternating-current resistance.

The impedance of a condenser decreases with an increase in frequency, but the impedance of an inductance increases with an increase in frequency. When, however, the circuit under consideration has uniformly distributed constants; resistance, capacity, inductance and leakage throughout its length, as in the case of long loaded cable circuits, there is a limit to the sending end resistance, known as the "characteristic impedance" due to the fact that additional length of circuit adds additional leakage paths and the total joint resistance to the application of a definite voltage of a given frequency does not increase beyond a certain point. As previously stated, the power is attenuated along the line towards the receiving end and is measured in decibels. When two circuits are joined together, or lines and apparatus are linked together, the best condition for the transfer of power is when the impedances are equal, that is, matched. If the impedances are unequal there is an additional loss of power known as "transition loss".

A circuit when working is always completed or closed, that is, its ends are not left open, and this condition must always be obtained when measuring. The impedance of a telephone is roughly 600 ohms, hence repeaters, amplifiers and testing apparatus are designed to have a closing impedance of 600 ohms, usually by means of transformers or potentiometers.

If then we have an instrument which will read the attenuation or loss directly in decibels, losses in lines and apparatus and gains of amplifiers can be measured. Now at Z, we can measure the line loss between X and Z, with our instruments, and then arrange that the amplifier at Z shall gain an equal amount, or if this is not desired, a greater or a less amount. The instrument actually measures the alternating current volts, but is calibrated, that is, marked in decibels. The milliwatt, written 1 mW, previously referred to is the testing power used to measure the losses in telephone lines and is therefore a "standard," and is sometimes called "reference power."

Now assume that the loss between X and Z is 15 db and the loss between Z and Y is 9 db., and a circuit with a total loss, i.e., transmission equivalent (T.E.) of 3 db. is wanted.

Losses	15
	9
	—
	24
Gains required	21
	—
	3 db. T.E.
	—

Meaning 3 decibels below zero level.

The amplifier at Z must be set to give a gain of 21 db. Now in the complete amplifier there are two valves—Fig. 3—and as 4-wire circuits are being considered, there will be two lines, one in one direction, and one in the opposite direction, distinguished by letters such as U/D which means from up to down, and D/U which means from down to up. Transmission takes place from the Up station to the Down station on the U/D pair and from the Down station to the Up station on the D/U pair, as shown in Fig. 23.

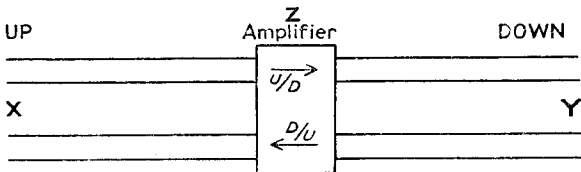

Fig. 23.

A telephone, however, is a 2-wire instrument; further, only two wires are used for short junctions and subscribers' circuits. So a way must be found of joining junctions or subscribers' circuits to the 4-wire amplified circuit.

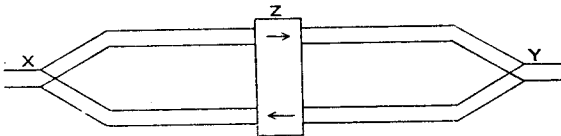

Fig. 24.

If the arrangement shown in Fig. 24 is set up and the two A's and the two B's of the two pairs of the 4-wire circuit joined to the two wires of the 2-wire circuit, it would be found that the amplified speech at Z when it arrived at Y, would return also on the other pair, as well as proceed to the subscriber on the 2-wire extension. The speech currents returning to X will not only disturb the speaker but will

continue to circulate around the 4-wire circuit and set up oscillation, which is sometimes called "singing" and sometimes "howl."

Unit, Terminating.—The method of connecting a 4-wire amplified circuit to its 2-wire end is as shown in Fig. 25.

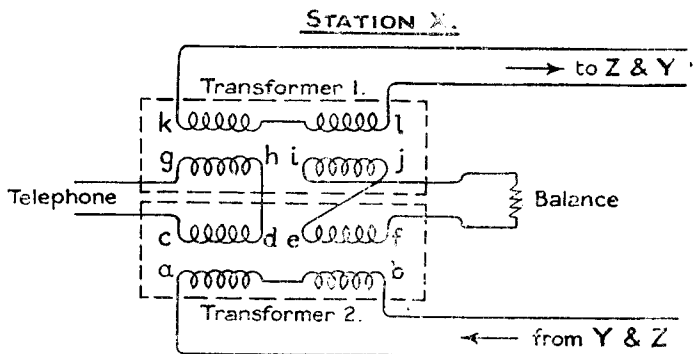

Fig. 25.

This arrangement is known as a "Unit, Terminating," and is used for connecting a 4-wire circuit to a 2-wire end or extension where an amplifier is not required.

At X, there are two ordinary line transformers. The cable pair transmitting speech from X to Y is joined to one winding *kl* of transformer 1, and the speech received in the direction from Y to X is joined to *ab*, one winding of transformer 2. The half winding *gh* of transformer 1 is joined to the half-winding *cd* of transformer 2, and the "2-wire" extension for connexion to junctions or subscribers' circuits is joined to the ends lettered *g* and *c*. The other two half windings *ef* and *ij* are joined together but the wires are crossed as shown, and the ends *i* and *f* are connected to a resistance which is known as a "balance."

When we speak into a telephone at X, speech currents are induced in the windings *kl* and *ab*. The current induced in *kl* travels along the line towards Y and is amplified at Z. The current in *ab* goes down the line towards Y, but when it reaches Z the valve in this pair is a plate towards Y, and as stated previously, the plate-to-grid circuit is practically a disconnection, and the current therefore ceases.

Now assume a current arriving from Y, amplified at Z, received through winding *ab* of transformer 2. This induces current in *cd* and *ef*. The current in *cd* passes to *hg* and the 2-wire telephone circuit. The current in *ef* circulates through

the balance and from i to j and induces a current from l to h . As the balance is assumed to be equal to the 2-wire telephone line, the currents in hg and ij are practically equal and as they induce opposite currents in the two halves of kl windings, they should cancel out. If the balance is not equal to the 2-wire extension, then there may be some current circulating in the kl winding and this will be dealt with later.

In speaking of the direction of currents in this explanation, only that part of the cycle which is rising or falling has been taken, because as each cycle is completed, the current flows in opposite directions.

Terminal Amplifier.—A Unit Amplifying No. 6 and a Unit Terminating would form a satisfactory terminal amplifier, but it is cheaper to design a terminal amplifier combining both items. The type of termination used in a terminal amplifier is shown separately in Fig. 26.

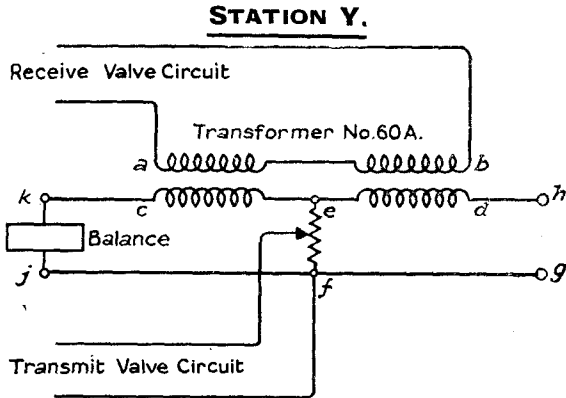

Fig. 26.

At Y, assuming a terminal amplifier to be fitted, there is incorporated a transformer wound in a special way. It has two windings; the primary consists of a single winding and the secondary of two half-windings, and great care is taken to see that the same number of wire turns are arranged on each half-winding.

It will be seen from the figure that there are three independent terminals, g , f and j , connected together. Between f and e there is a resistance of 300 ohms and this resistance is used as a potentiometer on the input winding of the transformer associated with the outgoing or transmitting pair. The

2-wire line or end is connected to terminals g and h , and the balance is connected to terminals j and k . The incoming or receiving circuit is connected to terminals a and b .

The speech currents, arriving at gh pass round circuit $gfeh$. There are two paths in shunt on this circuit, one, the balance $fjke$ (assumed to be equal to the 2-wire line) and the second, via the potentiometer to the outgoing circuit. The current in the direction $gfeh$ and the current through the balance $fjke$, induce currents in the ab winding. These pass along to the plate circuit of the receive valve of the amplifier and cease. The current flowing through the potentiometer fe passes to the grid of the valve of the outgoing line, and amplified speech currents pass on to Z or X .

A received current from X or Z passes, say, in the direction a to b . This induces currents in the half-windings ce , ed . These currents complete their circuits as follows, cef , j , balance, k , and edh , 2-wire line, gfe . The currents are assumed to be equal and pass in opposite directions through the potentiometer, and therefore cancel out, giving no volts on the grid circuit of the valve in the outgoing line. This then is the method adopted in terminal amplifiers to prevent transmitted or received speech from passing round the 4-wire circuit.

Units, Amplifying No. 5.—The complete arrangement for a Down Station is shown in Fig. 27, and is known as a Unit, Amplifying No. 5. It will be noticed that the potentiometer on the input transformer of the TRANS line is 300 ohms and not 600 ohms. This is necessary in order to keep the differential transformer (No. 60A) circuit arrangement correctly matched in regard to impedance. By this arrangement we reduce the gain by 3 db, and the maximum gain of the transmit half of the amplifier is therefore 3 db less than the maximum gain of the receive half of the amplifier, but as there is ample gain available, this causes no inconvenience.

The position is, then, that there are two cable pairs terminating as 2-wire ends with an amplifier at either or both ends. In addition there may be an intermediate amplifier, but no matter what the combination may be, a circuit of a specified transmission equivalent, usually written T.E. is required. Before the right amount of gain at each amplifier can be given, however, a meter for measurements must be available. Two types of meter have been issued, one is named Tester No. 109, and the other, Tester No. 104. There are only a few Testers 104 existing, and as Tester 109 is the standard instrument for transmission testing and setting-up of amplifiers, it will be briefly explained.

Tester No. 109.—Plate No. 8 is an illustration of the tester, and Plate No. 9 is a view of the top. The box on the right of Plate 8 is the tester, and the other box contains the batteries.

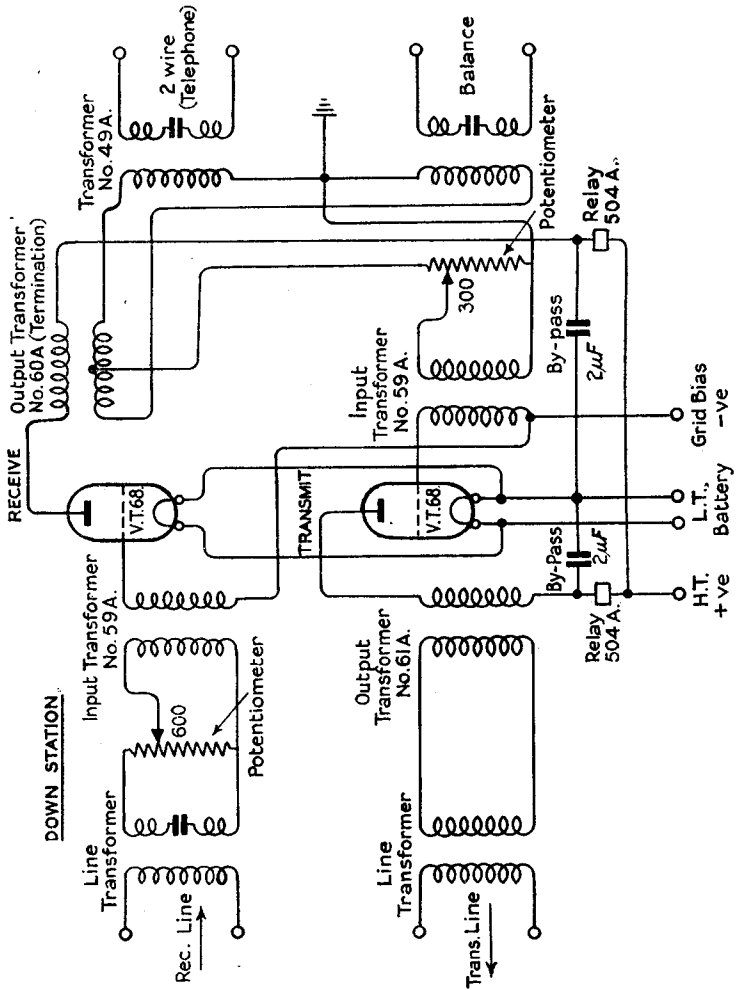

Fig. 27.

The high-tension battery consists of dry cells and furnishes 120 volts, and the low-tension battery is two 2-volt secondary cells. The batteries are connected to the tester by means of a cord and plugs. In some testers the plugs are made so that they can be put in the box only in one way, but in the earlier type, the plug could be put in either way. There is, of course, only one correct way, and if the plug is inserted the wrong way round, the battery will be left disconnected.

The tester consists of a valve oscillator which can be adjusted to deliver a power of 1 milliwatt at frequencies of 300, 500, 800, 1,400 and 2,000 cycles per second, and these frequencies are obtained by five condenser values. Normally the frequency used is 800 c.p.s., representing the mean frequency for speech. The arrangement is shown in Fig. 28.

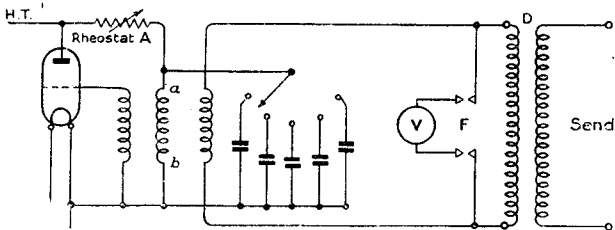

Fig. 28. Tester 109. Oscillator.

The output from the valve for the particular frequency required passes through transformer D to two terminals marked "send," and a voltmeter, V, can be placed across the primary of the transformer by means of a key, "F," which has several other functions. In series with the plate circuit of the valve is a variable resistance, A, and the output of the valve can be adjusted by this means.

The receiving part of the tester enables losses or gains to be measured. It consists of a tapped transformer and an amplifying valve, see Fig. 29.

The transformer has tappings on both windings and the tappings are brought out to a switch, labelled G. The taps on the primary winding each have a difference of 1 db, and the taps on the secondary winding each have a difference of 10 db; altogether, a range of 40 decibels in steps of 1 db can be obtained. The switch is marked in such a way that the reading appears in a small window forming part of the switch, and there is no difficulty in knowing whether the reading is a plus or minus figure.

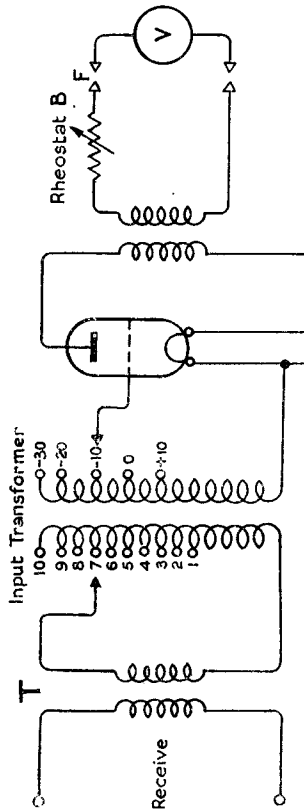

Fig. 29. Tester No. 109. Receiving Amplifier.

Valves are not always identical in behaviour, and as a measuring instrument must be accurate a means is provided of calibrating the set to ensure accuracy. The arrangement consists of resistances joined in a suitable manner to give a loss of 15 db. This arrangement is called an "attenuator" or "pad." If, therefore, the pad is measured by means of the instrument and a reading of 15 db is registered, the instrument will be correctly set or calibrated, and the way this is done is as follows:—

A key marked E on the set is thrown to a position marked "check" and when this is done, the oscillating or sending section of the instrument is joined to one side of the pad and the receiving section to the other side. First, key F is operated

to "send," and this places the voltmeter across the oscillator transformer. Resistance A is then adjusted until the voltmeter needle rests at the central point, which is within two red lines. 1 milliwatt is then being sent into the 15 db pad at the frequency required. Switch G is now placed to -15 db. Key F is then thrown to the "receive" position, and this places the voltmeter across the output of the receiving valve; if the instrument is correctly adjusted, the needle will again rest at the central point between the red lines. If it does not, then there is another resistance, B—Fig. 29—which can be varied until the needle is correctly positioned. The instrument is now calibrated, but care must be taken to see that so long as measurements are being made, the same frequency must be used and knob B *must on no account be moved*: further, if the frequency is changed, the instrument must be re-calibrated at that frequency. Full details of Tester 109 and information as to the method of use, are available in Engineering Instructions, TRANSMISSION, Telephone F1002.

Transmission or Level.—Fig. 29 is not complete. Vital parts were left out for the sake of simplicity, but now that the working of the tester has been explained, the missing parts can be introduced, and they are shown in Fig. 30.

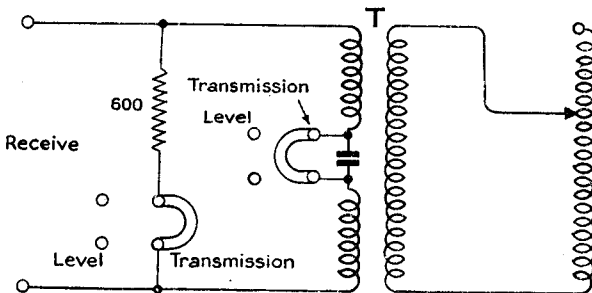

Fig. 30.

It will be noticed that there is a 600-ohm resistance which is joined across the "receive" terminals by the insertion of a U link, and at the centre point of the primary of the transformer, T (see also Fig. 29), there is a condenser which normally is short-circuited by a U link. When making transmission measurements, the U links are placed in the test holes marked "transmission." The 600-ohm resistance is for the purpose of matching the receiving tester to the sending tester.

When taking a level test, the measuring instrument must be of a relatively high impedance to the circuit tested. In order to create the condition for level tests, the U links are transferred from the test holes marked "transmission" to those marked "level." The 600-ohm resistance is thereby disconnected and the reason for this is that at any intermediate testing point the circuit is already closed by the continuation of the line circuit or the amplifier apparatus. A condenser is also placed in circuit at the centre point of the primary winding of the transformer. There are no connexions to the "level" test holes, and they are provided to ensure first, that the necessary testing conditions are obtained, and secondly, to avoid loss or misplacement of the U links. The U links can be seen in Plate 9, one on each side. The reason for the condenser is to enable level tests to be taken under ordinary working conditions when a direct signalling current may be circulating in the circuit under test, and the condenser prevents the current flowing through the transformer.

SETTING-UP A CIRCUIT

It is now proposed to set up a 4-wire amplifier circuit and an explanation of the easiest type of circuit will be given. There are many different arrangements of amplified circuits, and they are detailed in Engineering Instructions, TRANSMISSION, Telephone U3052-3060.

A simple amplifier circuit consists of a 4-wire line and two terminal amplifiers at the ends, shown in skeleton form in Fig. 31.

The transmission equivalent of the circuit to be set-up and other details will be supplied on a copy of Form TE886. The cable pairs will be assigned as U/D which means Up to Down, and D/U, which means Down to Up. This is necessary in order to know how the cable pairs shall be connected to the respective amplifiers. One station will be named as the control station, usually the Up station. The description "Up" does not refer specifically to the larger exchange, nor does "Up" mean the station nearer London. Owing to the many arrangements which are possible, a particular amplifier station may be the "Up" station to certain exchanges and "Down" to certain other exchanges. The word "control" means that the control station is responsible for the necessary records and reports, and for completion of the circuit, and the officer at the control station settles any difficulties that may arise.

At the Up station, the U/D pair is connected to the TRANS terminals of the amplifier by means of jumpering at the M.D.F. thus connecting the cable pair to the outgoing line transformer.

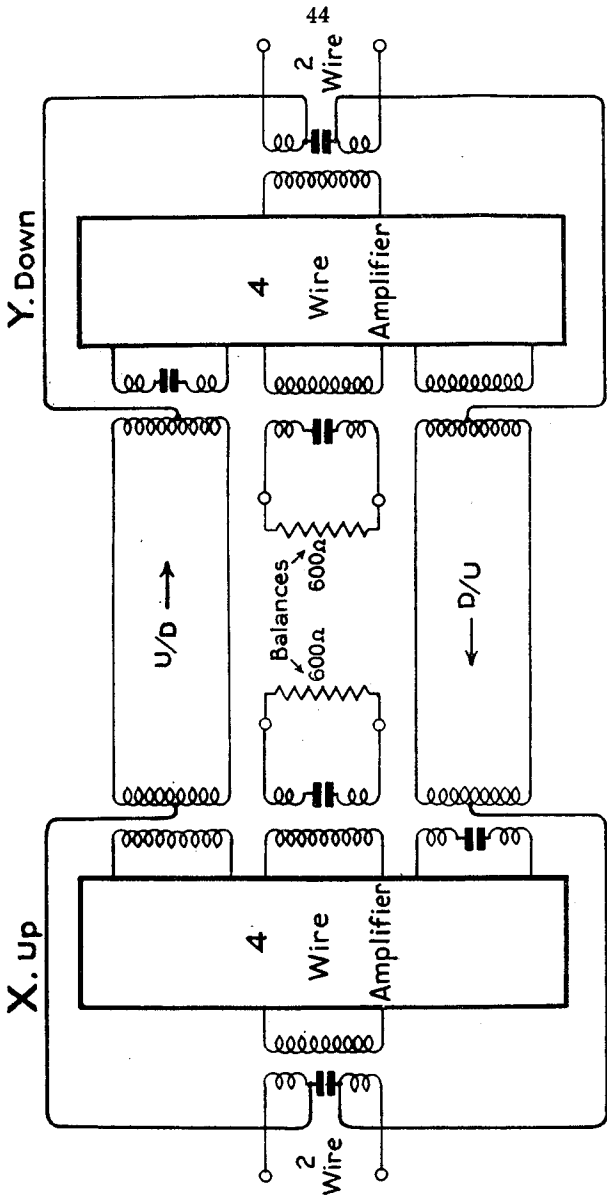

The D/U pair is similarly jumpered to the REC terminals on the same amplifier. The line fuses are inserted and the amplifier is now joined up. The Down station jumpers the U/D pair to the REC terminals of his amplifier, and the D/U pair to the TRANS terminals. It is assumed that the whole of the equipment has already been tested out and proved to be in order, so the first thing to be done is to see that the signalling circuit is through and in working order.

Turn back to Fig. 27. It will be observed that there are line transformers in the 2-wire line and in the balance. These transformers are 1 : 1 ratio, that is, they have the same number of turns on the primary and secondary windings and they are specially selected to be equal to each other, for it will be remembered that the balance must be made equal to the 2-wire end or extension.

It will be seen from Fig. 31 that the signalling is effected over the unloaded phantom circuit of the two pairs. The phantom is called "unloaded" because the effect of using the two wires in this way is to cause the loading-coil inductance to cancel out. The signalling wires are joined from the centre points of the 4-wire line transformers, to each side of the condenser in the line winding of the 2-wire end, and at Down stations the two wires are crossed. Direct-current signalling is therefore possible by this arrangement, provided the ohmic resistance of the line is not excessive.

The impedance of the condenser at 17 cycles per second is about 10,000 ohms, so that it is possible also to utilize the arrangement for 17-cycle signalling. At 800 cycles per second, the condenser has an impedance of only 200 ohms, and it is therefore satisfactory for the transmission of speech frequencies. The reason for testing the signalling is that failure to join up the circuit correctly may upset the measurements taken, and it is better to test the signalling circuit first, rather than carry out the measurements a second time.

The next thing is to make sure that balances have been fitted. Where the 2-wire ends are carried to switchboards in the same building, or are extended to lines having a loss not exceeding 3 db., the balance at each end will consist of a 600-ohm spool, and this is mounted at the top of the amplifier rack.

The officer in control at the Up station will now disconnect the 2-wire line at the M.D.F. and ascertain that the Down station has done likewise. Obviously in carrying out work of this kind, both stations will be in telephonic communication over a spare circuit. In setting-up the circuit, each direction

is dealt with separately, and when measurements are taken on the U/D line, the Up station makes the D/U line dead by placing the appropriate potentiometer lead on the O tap. To assist operations suitable clips should be soldered to two temporary potentiometer wander leads before commencing work.

The sending terminals of Tester 109 are now joined to the 2-wire test point, and the receiving terminals to the TRANS test point. There are sockets on the ebonite potentiometer block marked 2-WIRE, TRANS and REC. The U links are now placed in the LEVEL test holes on the tester, and 1 milliwatt at 800 cycles per second applied at the 2-wire test point, and the TRANS potentiometer then adjusted until a level reading of + 10 db. is recorded. It will probably be found that with the input transformer lead on tag 4, the potentiometer lead will be on tag 7.

The officer at the Down station will, in the meantime, have placed the U links of his tester in the TRANSMISSION test holes and joined the receive portion of his tester to his 2-wire test point. He then adjusts his REC potentiometer until a transmission measurement of - 3 db. is obtained if this is the overall transmission equivalent requested on Form TE 886. Each stop on a potentiometer alters the gain by 1.5 db., so that it is possible that exactly 3 db. may not be obtained, but a tolerance of ± 1 db. is allowed, and it should be possible to adjust to a value between 2 and 4 db. Both stations will record the potentiometer stops obtained.

The circuit is now set up in the U/D direction and the D/U direction is dealt with in exactly the same way. This time, however, the Up station makes the U/D line dead, and sees that the tester U links are placed in the TRANSMISSION test holes and the Down station uses the LEVEL test holes.

The Down station sends 1 milliwatt at 800 cycles per second, takes a level measurement to prove that the output at his amplifier is + 10 db. and the Up station adjusts the REC potentiometer until a transmission measurement of - 3 db. is obtained. The correct potentiometer stops are restored and the circuit is now set up at - 3 db., ± 1 db. in both directions.

If attempts were made to set up the circuit at an overall transmission equivalent of 0 db., that is, zero, it would be found that the circuit would tend to become unstable. This condition is difficult to explain in simple language, but it may be likened to reaction in a wireless receiver. In reaction, some of the valve output is returned to the input and it is well known that if too much is returned, the receiver will

oscillate, or howl. This is what happens when an amplified circuit is set at zero unless special precautions are taken by means of additional apparatus, which complicates the circuit very considerably and increases its cost, so the minimum transmission equivalent advisable is -3 db. Also, it will have been observed in wireless reception that before the receiver actually oscillates, the music becomes distorted, and this is exactly what takes place in an amplified circuit, if the stability of the circuit is not good. The "stability of a circuit," is the amount in decibels that the circuit is "off" the howling condition, that is, the amount that the overall loss can be decreased without the circuit actually howling.

In a simple 4-wire circuit such as has been set up, the circuit will howl if made slightly less than zero, so that the circuit will have a stability of just under 3 db., and further, it has been found that if a circuit has 2 db. stability when the 2-wire line is disconnected, speech will be free from distortion. When setting up a circuit which has a long 2-wire extension instead of a 2-wire end to the switchboard, the 4-wire portion of the circuit is set up exactly as already explained, and then the 2-wire line is joined up and further tests are made; but for these tests, and for various other combination of circuits, reference must be made to Engineering Instructions, TRANSMISSION, Telephone U3052-3060.

Stability Test.—The balance must be checked to prove that it is not disconnected or short-circuited; the stability test proves this. First, verify that the 2-wire lines at the Up and Down stations are disconnected. The control station then listens across the TRANS or REC test points, using a pair of Headgear Receivers No. 5F. This type of receiver has a high impedance and will not therefore affect the circuit. If the circuit fails to howl, it proves that the balances are not short-circuited. Now short-circuit the 2-wire lines at the Up and Down stations and again listen across the TRANS or REC test points. If the circuit does not howl, it proves that the balance is not disconnected.

In the case of more complicated circuits, the stability tests are more elaborate.

Soldering.—See that the potentiometer and transformer leads are correctly soldered, and that the 2-wire ends are joined through to the switchboards, and the circuit is ready for service.

Residual Mains Hum.—Earlier on, when dealing with mains hum, it was stated that any slight residual hum would be explained later. Turning to Fig. 27, it will be noticed that a

condenser is inserted in the receiving line transformer on the office side. The condenser arrangement can be adjusted so as to reduce low-frequency noises, and the final test for hum is to listen at the switchboard through a cord circuit. The hum may still be heard when the circuit is idle, but it should be so slight that it is not noticeable when carrying on a conversation.

BALANCES

It has been explained that in simple cases of 2-wire ends, or 2-wire line extensions not exceeding 3 db., a balance consisting of a 600-ohm resistance spool is usually entirely satisfactory. If, however, the 2-wire line has a transmission equivalent exceeding 3 db., a more elaborate balance must be arranged.

A cable pair has ohmic resistance and capacity, and if loaded, also has inductance and such a combination means that the impedance of the cable pair varies with frequency; as speech is composed of many frequencies, the balance should match the cable pair impedance at all frequencies.

Suppose, for instance, that the impedance of the cable is 600 ohms at 800 cycles per second, but 1,000 ohms at 2,000 cycles per second. If the balance is 600 ohms, then it will be equal to the line only at 800 cycles per second, and at 2,000 cycles per second the conditions at the 4-wire 2-wire terminations will be such that the circuit will probably howl at a frequency note of 2,000 cycles per second. This means that a balance must be found which will have a varying impedance at all the different frequencies to be transmitted. In fact, it must vary as nearly as possible at all these frequencies as does the impedance of the cable pair. Such a balance is obtained only by combining resistors, condensers and inductors, and the form in which they are combined depends upon the line characteristics of the cable pair that is to be balanced.

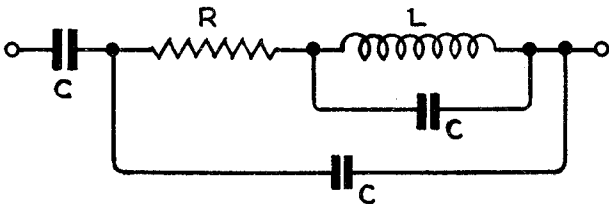
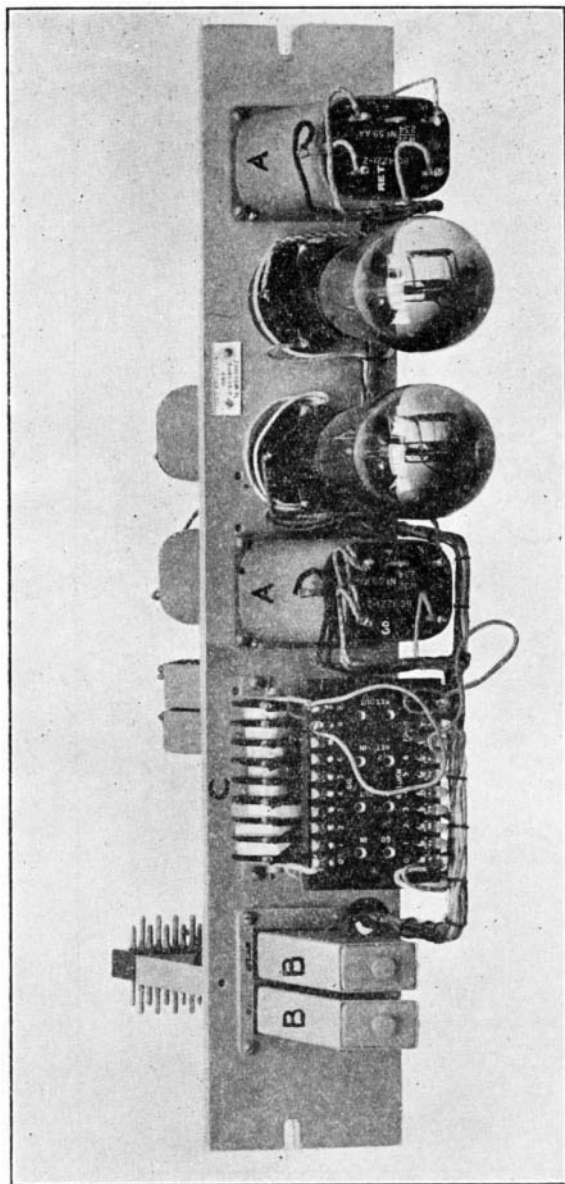

Fig. 32.

Fig. 32 shows one form of balance for a loaded cable pair. The various values of the components will be different for different types of cable but it is not necessary to make calculations as the particulars of the balance will be supplied on Form TE886, and all that is required is to obtain the various parts and connect them together. More detailed information about balances is contained in E.I. TRANSMISSION, Telephone, R1101-1108.

This then is the story of the 4-wire amplifier, written so that the reasons underlying the official instructions dealing with amplifier circuits may be readily appreciated.



A.—INPUT TRANSFORMER.
B.—RELAY 504A.
C.—POTENTIOMETER.

PLATE 1.—UNIT AMPLIFYING No. 6—FRONT.

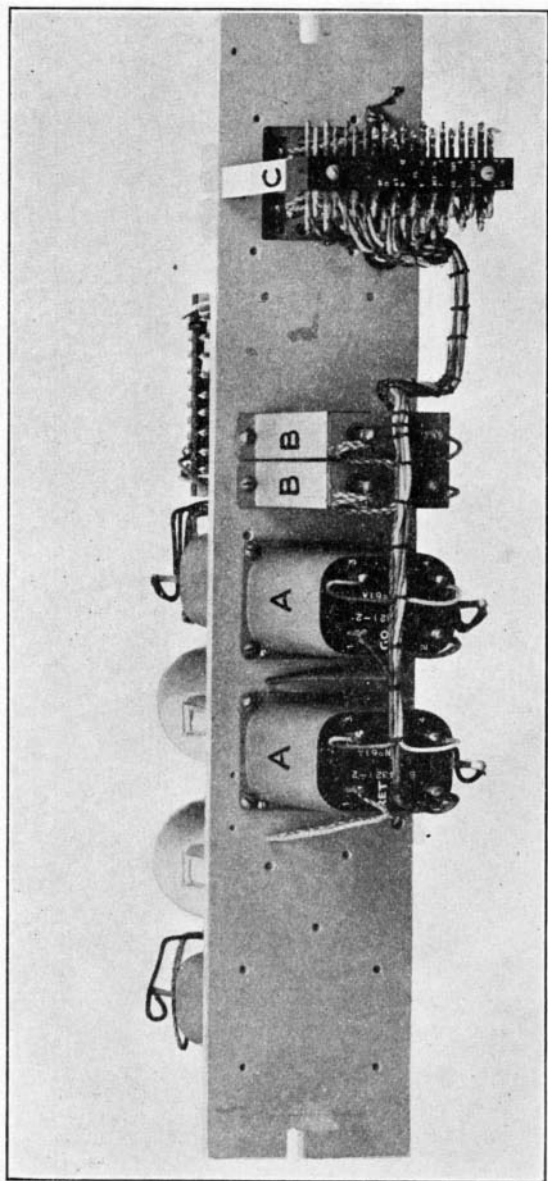

A.—OUTPUT TRANSFORMER.

B.—BY-PASS CONDENSER.

C.—TERMINAL STRIP.

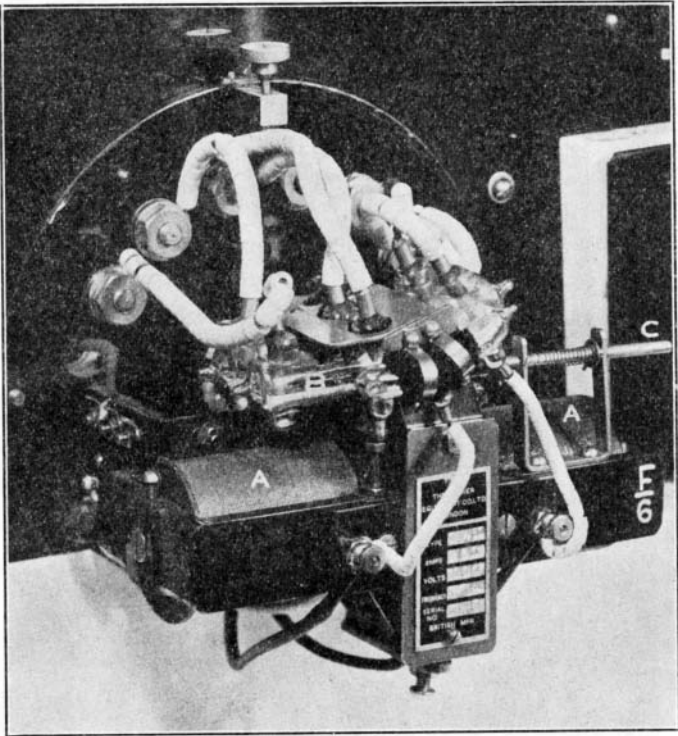

A.—ELECTRO MAGNET.
B.—MERCURY TUBES.
C.—HAND LEVER FOR RESETING ALARM TUBE.

PLATE 3.—MERCURY SWITCH—COVER OFF.

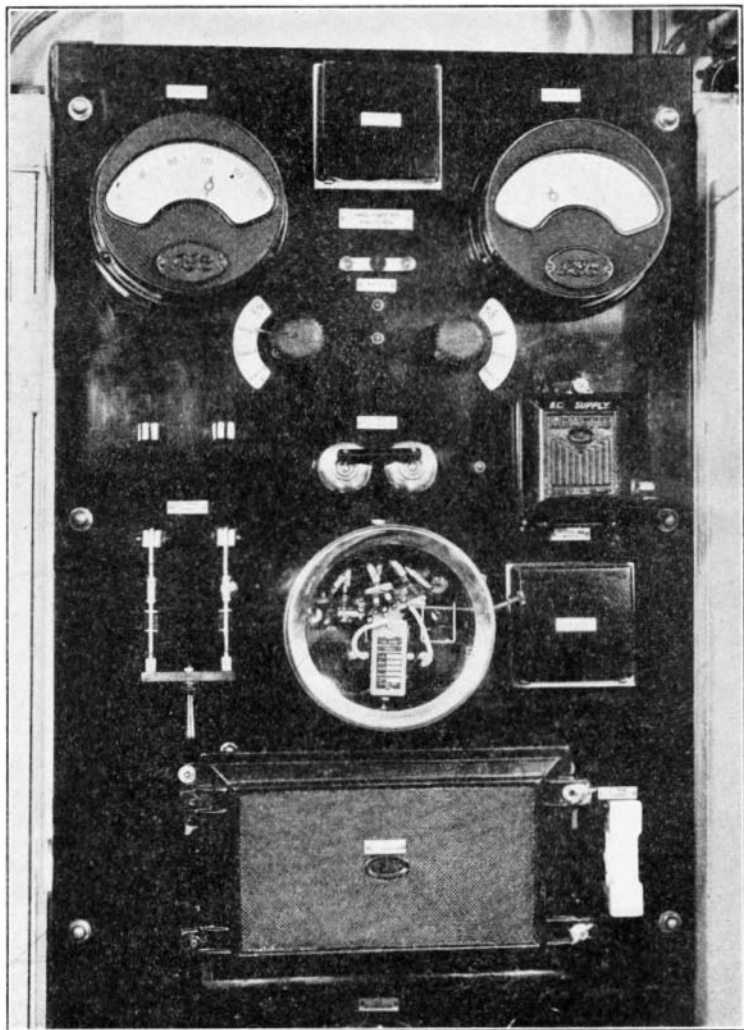
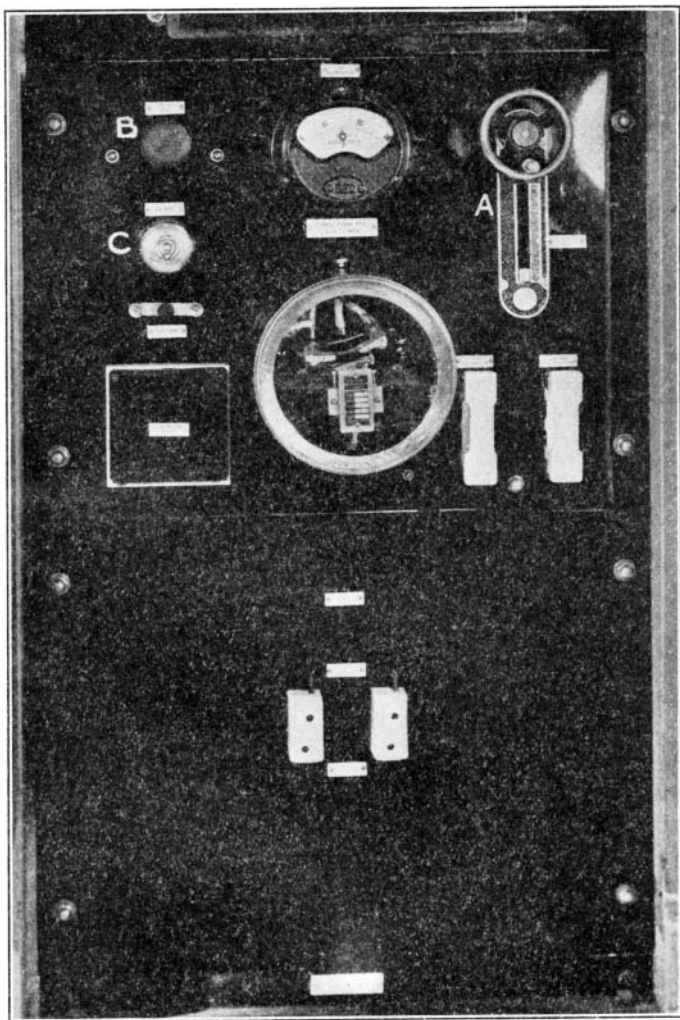
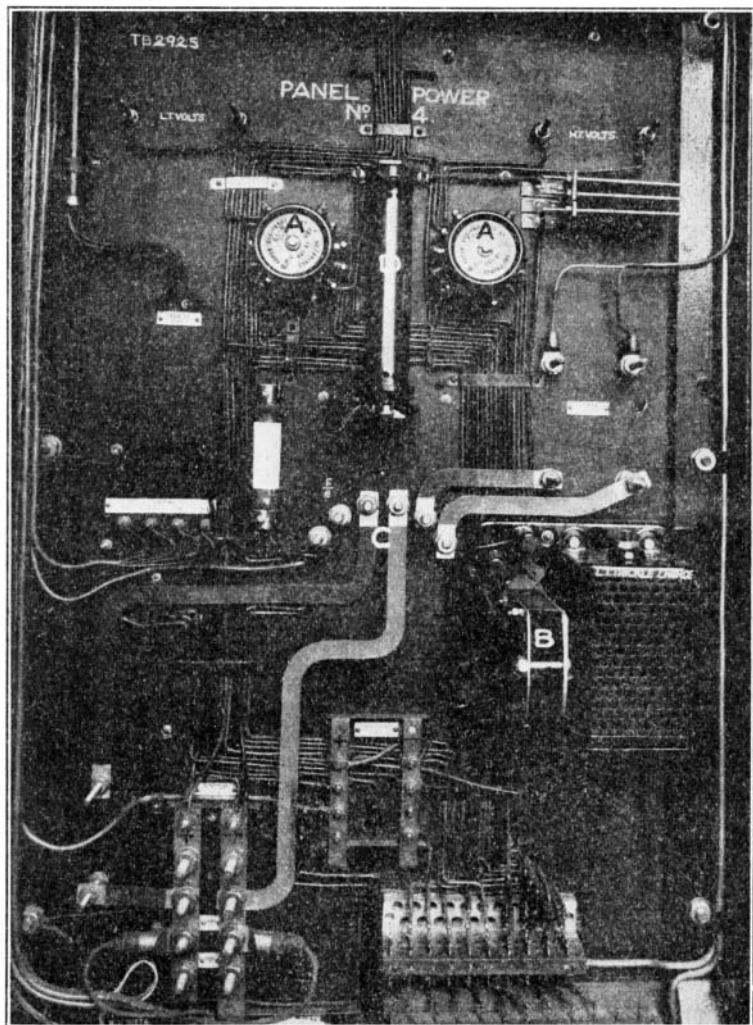

PLATE 4.—POWER PANEL NO. 4—FRONT.



A.—L.T. BATTERY REGULATOR.
B.—24 OHM L.T., A.C. REGULATOR.
C.—CHANGE-OVER TEST SWITCH.



A.—VOLTMETER SWITCH.
B.—L.T. TRICKLE-CHARGE TRANSFORMER.
C.—MERCURY SWITCH "F" TERMINALS.
D.—H.T. RECTIFIER.

PLATE 6.—POWER PANEL No. 4—REAR.

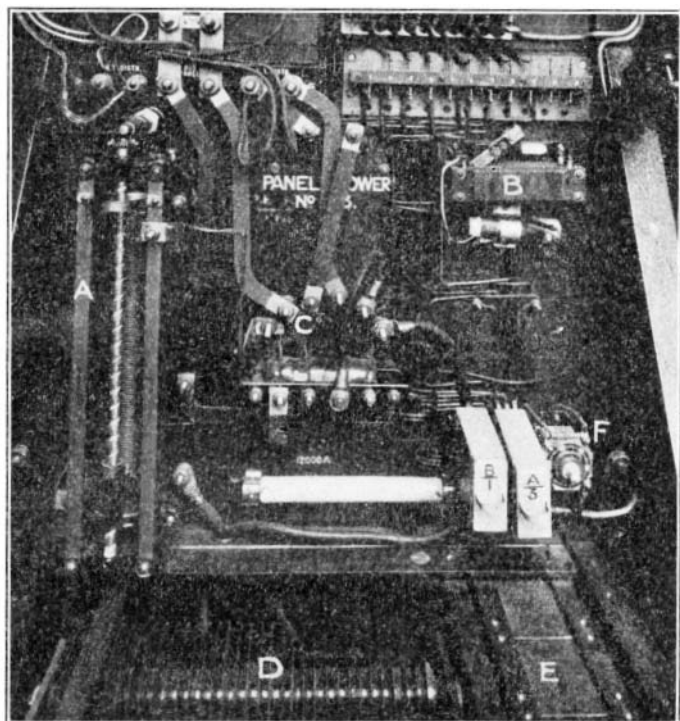

- A.—L.T. BATTERY REGULATOR.
B.—L.T. A.C. REGULATOR.
C.—MERCURY SWITCH "E" TERMINALS.
D.—H.T. RECTIFIER.
E.—H.T. SMOOTHING CIRCUIT.
F.—RECTIFIER FOR "A" RELAY.

PLATE 7.—POWER PANEL NO. 3—REAR.

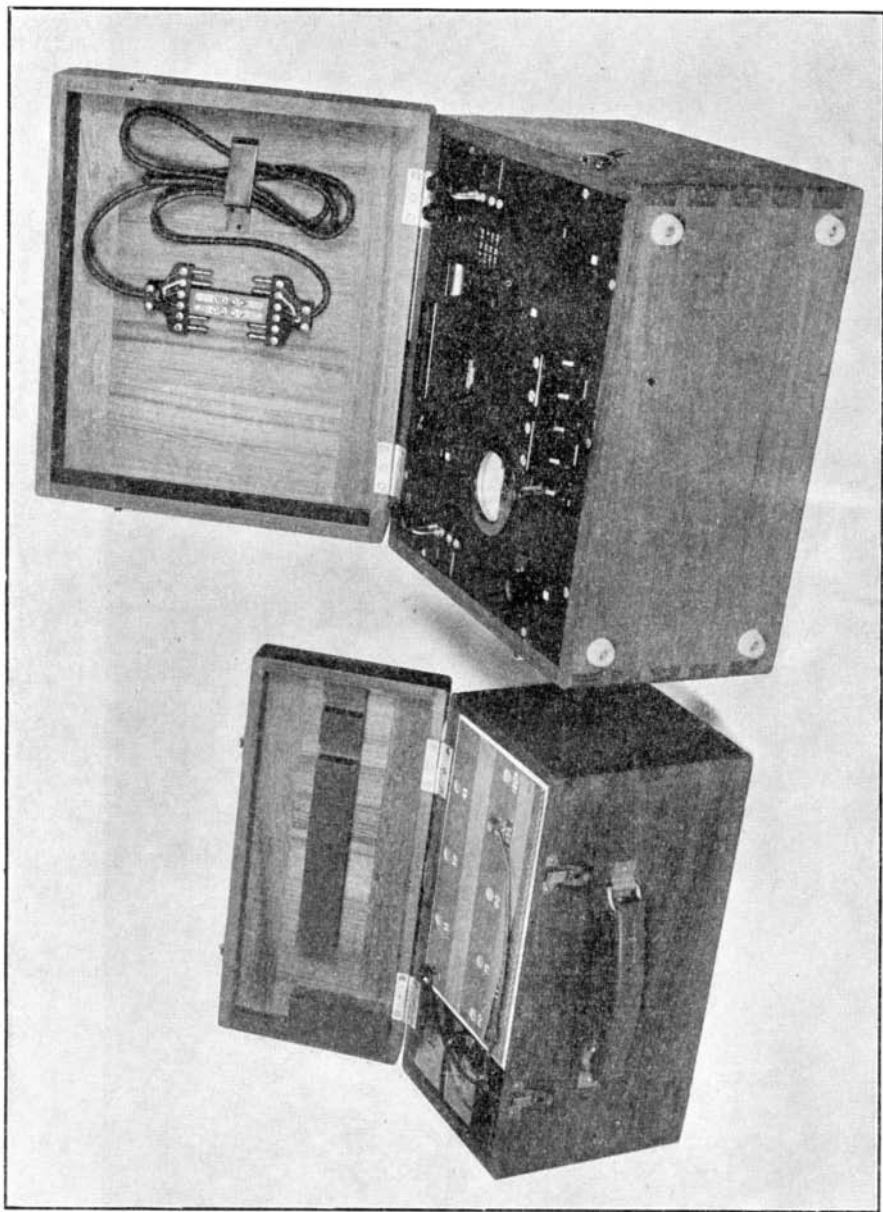

PLATE 8.—TESTER NO. 109 AND BATTERY SET.

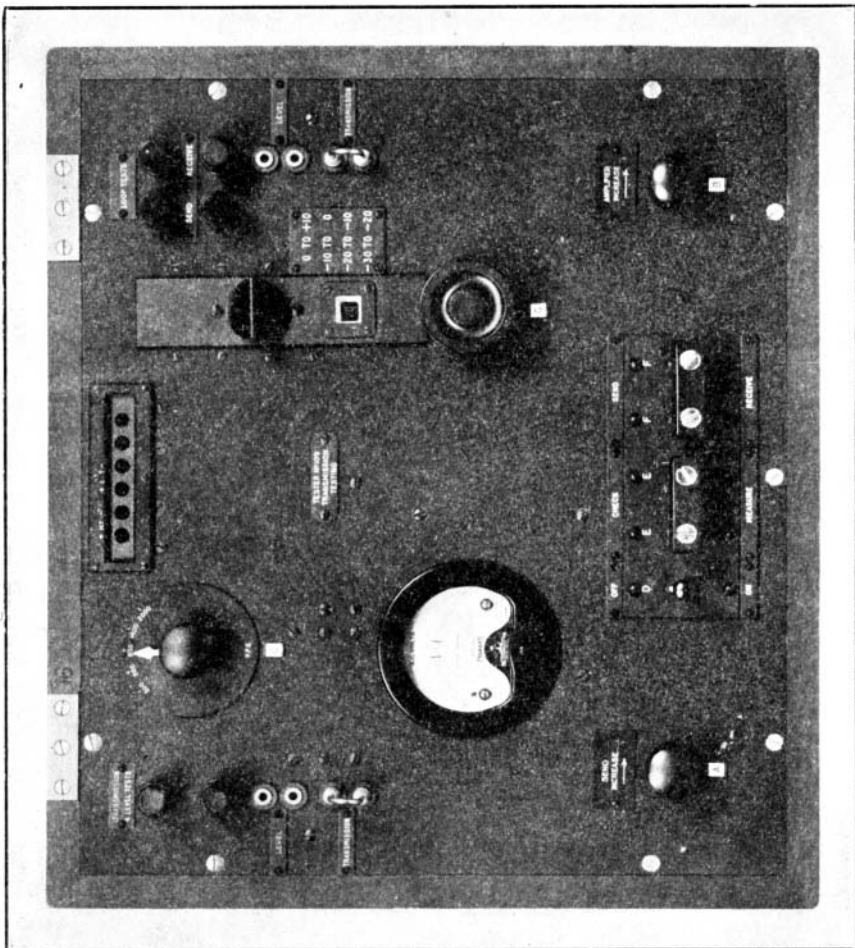

PLATE 9.—TESTER No. 109. VIEW OF PANEL.

LIST OF Technical Pamphlets for Workmen

(Continued)

GROUP D—continued

18. Distribution Cases, M.D.F. and I.D.F.
19. Cord Repairs.
20. Superposed Circuits. Transformers. Bridging Coils and Retardation Coils.
21. Call Offices.
22. Units. Amplifying. (*Not on Sale.*)

GROUP E

1. Automatic Telephony : Step-by-Step Systems.
2. Automatic Telephony : Coded Call Indicator (C.C.I.) Working.
3. Automatic Telephony : Keysending "B" positions.

GROUP F

1. Subscribers' Apparatus.—Common Battery System.
2. Subscribers' Apparatus, C.B.S. Part I—C.B.S. No. 1 System.
3. Subscribers' Apparatus. Magneto.
4. Private Branch Exchanges—Common Battery System.
5. Private Branch Exchange—C.B. Multiple No. 9.
6. Private Branch Exchanges—Magneto.
7. House Telephone Systems.
8. Wiring of Subscribers' Premises.

GROUP G

1. Maintenance of Secondary Cells.
2. Power Plant for Telegraph and Telephone Purposes.
3. Maintenance of Power Plant for Telegraph and Telephone Purposes.
4. Telegraph Battery Power Distribution Boards.

GROUP H

1. Open Line Construction, Part I.
2. Open Line Construction, Part II.
3. Open Line Maintenance.
4. Underground Construction, Part I—Conduits.
5. Underground Construction, Part II—Cables.
6. Underground Maintenance.
7. Cable Balancing.
8. Power Circuit Guarding.
9. Electrolytic Action on Cable Sheaths, etc.
10. Constants of Conductors used for Telegraph and Telephone Purposes.

GROUP I

1. Submarine Cables.

GROUP K

1. Electric Lighting.
2. Lifts.
3. Heating Systems.
4. Pneumatic Tube Systems.
5. Gas and Petrol Engines.