

*Crown Copyright Reserved*

PW—D 16

**Post Office Engineering Department**

---

**TECHNICAL PAMPHLETS  
FOR WORKMEN**

---

*Subject:*

**Routine Testing for  
Manual Telephone Exchanges**

**ENGINEER-IN-CHIEF'S OFFICE**  
*May, 1934*

---

*(Reprinted, March, 1935, incorporating amendments to date.)*  
( „ December, 1935, „ „ „ )

---

LONDON  
PRINTED BY HIS MAJESTY'S STATIONERY OFFICE

# LIST OF

## Technical Pamphlets for Workmen

### GROUP A

1. Magnetism and Electricity.
2. Primary Batteries.
3. Technical Terms.
4. Test Boards.
5. Protective Fittings.
6. Measuring and Testing Instruments.
7. Sensitivity of Apparatus.
8. Standard List of Terms and Definitions used in Telegraphy and Telephony. (*Not on Sale.*)
9. Standard Graphical Symbols for Telegraphy, Telephony and Radio Communication. (*Not on Sale.*)

### GROUP B

1. Elementary Principles of Telegraphy and Systems up to Morse Duplex.
2. Telegraph Concentrators.
3. Wheatstone System. Morse Keyboard Perforators.
4. Quadruplex, Quadriplex Repeated Circuits and Telegraph Repeaters, Simplex and Duplex.
5. Hughes Type-printing Telegraph.
6. Baudot Multiplex Type-printing System.
7. Western Electric Duplex Multiplex. Murray Duplex Multiplex. Siemens and Halske Automatic Type-printing System.
8. Fire Alarm Systems.

### GROUP C

1. Wireless Transmission and Reception.
2. Interference with Reception of Broadcasting.

### GROUP D

1. Elementary Principles of Telephony.
2. Telephone Transmission. "Loading." Telephone Repeaters and Thermionic Valves.
3. Principles of Telephone Exchange Signalling.
4. Magneto Exchanges—Non-Multiple Type.
5. Magneto Exchanges—Multiple Type.
6. C.B.S. No. 1 Exchanges—Non-Multiple Type.
7. C.B.S. Exchanges—Multiple Type.
8. C.B. Exchanges—No. 9 Type.
9. C.B. Exchanges—No. 10 Type.
10. C.B. Exchanges—No. 12 Type.
11. C.B. Exchanges—22 Volts.
12. C.B. Exchanges—40 Volts.
13. Trunk Telephone Exchanges.
14. Maintenance of Manual Telephone Exchanges.
15. Telephone Testing Equipment.
16. Routine Testing for Manual Telephone Exchanges.
17. Internal Cabling and Wiring.
18. Distribution Cases, M.D.F. and I.D.F.
19. Cord Repairs.

[Continued on page iii of Cover.]

## FOR OFFICIAL USE

### CORRECTION SLIP TABLE

The month and year of issue is printed at the end of each amendment in the Correction Slips, and the number of the slip in which any particular amendment is issued can, therefore, be traced from the date. In the case of short corrections made in manuscript, the date of issue of the slip should be noted against the correction.

The Summary portions of the Correction Slips should be completed and affixed below in numerical order.

---

### **CORRECTION SLIP TABLE—(cont.)**

The month and year of issue is printed at the end of each amendment in the Correction Slips, and the number of the slip in which any particular amendment is issued can, therefore, be traced from the date. In the case of short corrections made in manuscript, the date of issue of the slip should be noted against the correction.

The Summary portions of the Correction Slips should be completed and affixed below in numerical order.

---

# ROUTINE TESTING FOR MANUAL TELEPHONE EXCHANGES. (D 16)

---

---

*The following pamphlets in this series are of kindred  
interest :—*

- A 6 Measuring and Testing Instruments.**
- D 1 Elementary Principles of Telephony.**
- D 2 Telephone Transmission. "Loading." Telephone Repeaters  
and Thermionic Valves.**
- D 3 Principles of Telephone Exchange Signalling.**
- D14 Maintenance of Manual Telephone Exchanges.**
- D15 Telephone Testing Equipment.**

# ROUTINE TESTING FOR MANUAL TELEPHONE EXCHANGES.

(D 16)

---



---

## TABLE OF CONTENTS.

	PAGE
<b>I.—Routine Tests made at C.B. Exchanges by the Traffic Staff:—</b>	
CORD CIRCUIT TESTS ... ..	5
<b>OTHER ROUTINE TESTS:—</b>	
TELEPHONISTS' HEADGEAR RECEIVER AND B.P. TRANSMITTER ... ..	9
PLUG-ENDED JUNCTION CIRCUITS ... ..	9
JACK-ENDED JUNCTION CIRCUITS ... ..	10
INFORMATION DESK, SUPERVISORS' AND MISCELLANEOUS CIRCUITS ... ..	10
DAY AND NIGHT ALARM SIGNALS ... ..	10
SUBSCRIBERS' CALLING EQUIPMENT ... ..	11
INSULATION TEST OF SUBSCRIBERS' LINES ... ..	11
RINGING KEYS ON MANUAL POSITIONS ... ..	12
SUBSCRIBERS' AND OUTGOING JUNCTION MULTIPLE ...	13
CONTACT TEST OF SLEEVE CONNEXIONS OF JACKS ...	13
SUBSCRIBERS' METERS ... ..	14
FIRE AND OTHER EMERGENCY EQUIPMENT AND CIRCUITS ... ..	16
 <b>II.—Routine Tests made at C.B. Exchanges by the Engineering Staff, and the Apparatus used:—</b>	
GENERAL ... ..	16
SCHEDULE OF OPERATIONS WHEN USING TESTER No. 28c	19
TEST OF RESISTANCE LAMPS ON P.B.X. POWER RINGING LEADS ... ..	29
TEST OF SUPERVISORY AND PILOT LAMP CAPS ... ..	29
<b>APPARATUS USED BY MAINTENANCE STAFF FOR THE LOCALISATION OF FAULTS:—</b>	
TESTERS NOS. 5 AND 5A ... ..	29
TESTER No. 6 ... ..	30
TESTER No. 40 ... ..	30
LOCALISATION LAMPS ... ..	31
TESTER No. 17 ... ..	31
TESTER No. 45 ... ..	31
TESTER No. 39 ... ..	31
TESTERS NOS. 89 AND 89A ... ..	31
EXAMINATION OF TESTERS ... ..	32

# **ROUTINE TESTING FOR MANUAL TELEPHONE EXCHANGES.**

The efficiency of a Telephone System so far as the plant is concerned is largely dependent on the efficiency of the routine tests made periodically on that plant.

The ideal to be aimed at is that the Service should not be interrupted by faults on any part of the equipment or apparatus.

With the delicate and complicated apparatus necessary to provide a modern telephone system this ideal condition cannot always be maintained, but it is possible to approach closely to this condition if the plant is properly tested and adjusted at sufficiently frequent intervals.

All sections of the plant are subjected to tests from time to time, but the frequency of the tests that are necessary will vary for different portions of the equipment; for example, the connecting cords, owing to the constant handling they receive, and being necessarily of a flexible nature, need testing most frequently, whilst other apparatus, such as multiple jacks and wiring, requires to be tested at less frequent intervals.

The arrangements provided in a Telephone Exchange for the routine testing and adjustment of the equipment can be divided conveniently into the following sections:—

- (1) Routine tests made by the Traffic Staff.
- (2) Routine tests made by the Engineering Staff.

The testing arrangements outlined hereafter refer more particularly to C.B. Exchanges, but similar systems are in vogue in all other types of exchange, the facilities provided being specially designed to meet the particular requirements of the various types of equipment.

---

## **SECTION I.**

### **TESTS MADE AT C.B. EXCHANGES BY THE TRAFFIC STAFF.**

#### **CORD CIRCUIT TESTS.**

The circuit arrangements described in this Section are those adopted for the routine tests made by the Traffic Staff of cords on subscribers' and junction positions, information desks and exchange testing positions.

The primary object of the arrangements is to furnish the telephonist with a ready means of testing all cords on the position for intermittent disconnexions. This is effected by the provision of special circuits terminating on switchboard jacks, known as "Cord Test" jacks, and so arranged that, when the plug of the cord to be tested is inserted in the jack, a current flows through each conductor of the cord and at the same time provides suitable arrangements for detecting in the receiver of the telephonist any variations in these currents.

At some of the older exchanges the "Cord Test" circuits vary somewhat in detail from the circuits described hereafter, but the principle of operation is approximately the same in both cases.

The circuits described in this Section are not necessarily intended to provide a severe test for the relays on the cord circuits, but their use enables many relay and other faults to be detected whilst the telephonist is making the daily test of cords, which would otherwise probably not be brought to notice until the less frequent adjustment test of the relays is made by the Engineering Staff, or until a fault had caused an interruption in the service.

The resistances fitted are such as to permit a current to flow through the coils of the supervisory relay, which is slightly in excess of the minimum operating current for the type of relay in use. See Technical Pamphlet on "Sensitivity of Apparatus," PW—A7.

The cord circuit diagrams quoted in the letterpress are only typical and do not embrace every variation. They have been chosen to indicate the principles of testing.

**Cord Circuits on Subscribers' and Jack-ended Junction Positions and Information Desks.**—Typical Cord Circuit connexions are shown in Loose Leaf Diagrams K 200, K 201 and K 204. The "shake test" of the cords on these positions is made in connexion with special Cord Test Jacks, one of which is fitted on each section and connected as shown in Fig. 1 of Loose Leaf Diagram K 1700.

The plug of the cord to be tested is inserted into one of these jacks and the cord then shaken. By listening on the telephonist's instrument, having first thrown the key associated with the cord circuit under test, it can be ascertained whether there are any intermittent disconnexions in the *tip*, *ring* and *sleeve* conductors of the cord.

In carrying out these tests it will be noted that:—

(a) There is a momentary flash of the supervisory lamp during the insertion of the plug. This proves that the third conductor of cord and supervisory lamp are in order.

(b) The supervisory lamp is darkened when the plug is fully inserted. This indicates that the supervisory relay operates correctly and that there is no disconnexion in the tip and ring conductors.

(c) There is no scraping noise in the receiver when the cord is shaken. This indicates freedom from intermittent disconnexions.

Whilst any speaking key is thrown, tap the tip of the calling plug corresponding to the key thrown against the sleeve of any other plug on the position. The engaged "click" should be heard.



At all C.B. exchanges, except those where a single battery is installed, the operator's effective meter should be tested as follows:—

Whilst any answering plug is in the cord test jack, restore the speaking key, depress the cord circuit meter key and note that the meter pilot lamp does *not* glow.

At Exchanges where cord circuits without battery are in use on Information Desks, the cord test jacks are connected as indicated in Fig. 2 of Loose Leaf Diagram K 1700, in which provision is made for the necessary battery current for testing purposes. The procedure in making the test is exactly the same as that just described.

**Cord Circuits on Plug-ended Junction Positions where the "B" Lines of the Cord Circuits are Connected to Battery Normally.**—*Typical Cord Circuit Diagram K 500.* These cords are tested in conjunction with special cord test jacks, one of which is fitted on each position. The circuit connexions of the cord test jack are shown in Fig. 4 of Diagram K 1700. The plug of the cord to be tested is inserted into the Test Jack and the cord then shaken.

The 1,000 $\Omega$  resistance connected to the bush of the cord test jack prevents the sleeve relay in the junction circuit from actuating, the circuit being completed from the negative pole of the battery through the sleeve relay, *sleeve conductor of cord*, the 1,000 $\Omega$  resistance spool, telephonist's receiver, *tip conductor of cord*, resting contact of sleeve relay and the engaged test winding of the induction coil, to earth. The current from the battery connected normally to the "B" line flows through the *ring conductor of cord*, 1,000 $\Omega$  resistance spool, and thence to earth, *via* the receiver, tip conductor, resting contact of sleeve relay and one winding of induction coil as before. By listening on the telephonist's instrument when shaking the cord, it is thus possible to detect any intermittent disconnexions in the tip, ring and sleeve conductors of the junction cord under test, as will be seen by reference to Fig. 4 of Diagram K 1700.

It will also be noted that (1) a "click" is heard in the receiver upon inserting the junction plug into the cord test jack; (2) the junction lamp does not glow when the plug is fully inserted; (3) the "engaged click" is heard when the tip of the plug is tapped against the sleeve of the next plug on the position.

**Cord Circuits on Plug-ended Junction Positions where the "B" Lines of the Cord Circuits are not Connected to Battery Normally.**—*Typical Cord Circuit Diagram K 801.*—These cords are tested in conjunction with special cord test jacks, one of which is fitted on each position, the circuit arrangements being in accordance with Fig. 5 of Diagram K 1700. The cords are tested in the same manner as the cords on the other junction positions previously referred to. Battery current for testing is obtained

*via* the relay associated with each cord test jack. This arrangement obviates the necessity for inserting a plug at the outgoing end of the junction whenever a "shake test" is required.

It will be seen that when the junction plug is inserted in the cord test jack the relay connected to the auxiliary springs of the jack is energised and a current flows from the battery *via* the sleeve relay and *sleeve conductor of cord*, telephonist's receiver, *ring conductor of cord*, resting contact of "B" line connecting relay, 600 $\Omega$  resistance spool, and one of the contacts of the cord test relay, to earth.

The sleeve relay does not operate as the 600 $\Omega$  resistance fitted in the cord test circuit considerably reduces the value of the current necessary to operate that relay.

Another circuit through the *tip conductor of cord* is also completed from the negative pole of battery, *via* contact and armature of cord test relay, engaged test winding of induction coil, resting contact of sleeve relay, *tip conductor of cord*, telephonist's receiver, thence to earth *via the ring conductor of cord* and 600 $\Omega$  resistance spool, as before.

**Cord Circuits on Testing Telephonists' Positions. Howler and Supervisory Test and Plugging Up Cord Circuits.**—*Typical Cord Circuit Diagrams, K 1003 and K 1004.*—These cords are tested in conjunction with special cord test jacks, one of which is fitted on the testing telephonist's position. The jacks are wired in accordance with Fig. 3 of Diagram K 1700, and the tests are carried out in the same manner as for electrophone cords described previously, except that, in the case of the Howler cord, it is necessary to insert the plug of an ordinary answering cord circuit into the Howler circuit break jack in order to disconnect the "Howler" from the testing telephonist's instrument.

The lamp on the cord circuit under test should glow momentarily whilst the plug is being inserted into the "cord test" jack, thus verifying the connexion of the sleeve conductor of the cord.

**Cord Circuits on Test Extension Lines.**—*Typical Diagram K 1002.*—These cords are tested in co-operation with an officer at the test desk, except when battery is connected as in Fig. 3 of K 1002. The plug of the cord circuit to be tested is inserted into the special cord test jack on the testing telephonist's position (Diagram K 1,700, Fig. 3), whilst in regard to cords wired to Fig. 1 of K 1002 battery will be connected to the circuit by the test clerk. The test is then carried out by the telephonist in the manner already described for other cords on the position.

**General.**—The tests so far described cover the principal cord circuits in use in an exchange; the few miscellaneous cord circuits not referred to, such as those on supervisors' desks, etc., need

no special testing equipment as a rule, and can generally be tested in the same manner as cords on an ordinary subscriber's telephone instrument.

Cords in exchanges are tested at least once each day. The Traffic Staff carry out these tests and all faults found are recorded on the standard form which is handed to the Engineering Staff as early as possible after the tests are completed, so that any faults found can be remedied and the cord circuits put into service again before the busy period of the day arrives.

When carrying out the tests the telephonist reports all other defects noticed, such as frayed cords, missing plug covers, key tops, opals, loose jacks and spacing strips, etc. These defects are recorded on the standard form together with the cord faults.

#### OTHER ROUTINE TESTS CARRIED OUT BY THE TRAFFIC STAFF AT C.B. EXCHANGES.

##### **Telephonists' Headgear Receiver and B.P. Transmitter.**—

At some of the larger C.B. exchanges a special circuit is fitted for the use of telephonists for the purpose of testing the transmission efficiency of their instruments. The test is made over a circuit to a supervisor's desk, to which an artificial cable is connected.

Before a repaired instrument is brought into use it should be tested for transmission efficiency.

**Plug-ended Junction Circuits.**—(See Diagrams K 301 and K 500.)—A speaking and ringing test is made on each junction circuit by the Traffic Staff at a convenient time of the day or night.

At the time fixed for the test, the "A" telephonist advises the "B" telephonist, and the test then proceeds on the following general lines:—

The telephonist at the outgoing end plugs into the junction to be tested with a cord which is known to be in good order.

The "B" telephonist notes the signal, inserts the junction plug into the Ringing Test jack No. 1 (Diagram K 1702), observes that the lamp darkens, depresses the ringing key (except in the case of keyless ringing), and notes that the bell rings properly. The plug is then withdrawn and inserted into Ringing Test jack No. 2, and the ringing key (where fitted) is depressed. The key should release and prevent any further ring. In the case of keyless ringing junctions, the bell should not ring with the plug in jack No. 2.

The telephonist at the incoming end now extends the junction under test to a circuit terminating on an instrument where a second telephonist or supervisor speaks to the distant "A"

telephonist. It will be observed at each end that the transmission is satisfactory. The clearing lamps at both ends should darken.

The "A" telephonist then withdraws the plug and the "B" telephonist, after receiving the clearing signal, withdraws the plug and notes that the junction lamp is extinguished immediately.

The "A" telephonist will carry out the tests from a position situated at the end of the junction multiple, so as to include all the multiple cable at the exchange concerned.

Junctions which appear on the "B" multiple only at the outgoing end will be tested in a similar manner by using a spare cord on an incoming ringing junction position for signalling and speaking purposes.

The **Ringing test jacks** referred to in the foregoing test are wired to a pair of jacks common to a group of three "B" positions. The circuit arrangements are shown in Loose Leaf Diagram K 1702.

Ringing Test jack No. 1 is used for the purpose of ascertaining that the tripping relay will not operate on subscribers' lines having extra indicators or bells in parallel, whilst jack No. 2 is connected to a loop resistance of  $600\Omega$  through which the tripping relay should operate either on the ringing or silent interval of the junction ringing.

**Jack-ended Junctions** (Loose Leaf Diagram K 600).—A speaking and signalling test is made on each junction by the Traffic Staff.

At the time fixed for the test the "A" telephonist advises the "B" telephonist, and the test then proceeds on the following general lines:—

The telephonist at the outgoing end plugs into the junction to be tested with a calling cord which is known to be in good order. The "B" telephonist, on receipt of the calling signal plugs into the answering jack, speaks to distant telephonist, and observes that the transmission is satisfactory. The "A" telephonist then withdraws the plug and the "B" telephonist—after receipt of the signal on the supervisory lamp—withdraws the plug.

**Test of Information Desk, Supervisors' and Miscellaneous Circuits.**—A speaking and signalling test is made each day over all circuits to the Information Desk, and all Supervisors' and Miscellaneous Circuits used by the Exchange Staff.

**Test of Day and Night Alarm Signals** (Loose Leaf Diagram K 1904).—The test in the case of *Subscribers' positions* (Diagram K 101) is made by means of a  $750\Omega$  peg (Peg No. 13A or 24A), which consists of an ordinary switchboard plug with a  $750\Omega$  resistance coil accommodated in the barrel and connected across the tip and ring connexions.

The test is carried out as follows:—

A calling lamp on each panel or section is caused to glow by inserting the  $750\Omega$  peg into an answering jack, and noting that the corresponding panel pilot lamp glows, also that the night alarm bell or buzzer is actuated when the alarm key is in the appropriate position.

In the case of *order wire positions* (see Diagram K 1200), the telephonist at one of the distant exchanges will be asked to ring on the order wire. A glow is received on the order wire lamp and the night alarm signal is operated. The throwing of the re-setting key causes the cessation of the alarm signal.

*Ringin*g junction positions (see Diagram K 500) will be tested in a similar manner by obtaining a calling signal on one of the junctions and noting that a proper signal is received on the junction, position pilot lamp and alarm signal.

**Test of Subscribers' Calling Equipment.** (Typical Diagrams are K 101 and 1904.)—A test of each working subscriber's calling equipment is made by means of the  $750\Omega$  peg as follows:—

The  $750\Omega$  peg is inserted into a *multiple jack* of the line to be tested and adjacent to the answering position, or in cases where there is no subscriber's multiple on the "A" board the peg will be inserted into the answering jack. The line and pilot lamps (and ancillary lamps where these are installed) *immediately* glow, and they should darken *promptly* when the plug is withdrawn.

Where the test is made from the multiple, it will be ascertained that the number of the circuit at the answering position agrees with the multiple jack number.

It will be evident from a study of the relevant diagrams that if, in a particular test, the pilot lamp does not glow, although a glow is obtained on the subscriber's calling lamp, the fault may be due to the calling lamp being too high in resistance, thereby not allowing sufficient current to flow through the pilot relay.

In order to avoid trouble due to indicators at subscribers' premises being actuated a routine test of cut-off relays is not made.

**Insulation test of Subscribers' Lines.**—An insulation test is made of all subscribers' working lines from the Testing Telephonist's position. Every spare jack within reach of this position should be pegged to avoid tests being made and faults reported on lines that are not in use. Diagram K 1000 shows the connexions of an exchange test cord circuit.

The allowable insulation resistance limits should be taken and the equivalent limiting deflection on the voltmeter scale marked by means of the movable indicator. The position of the indicator should be checked periodically and readjusted when necessary.

The test is carried out by means of the testing telephonist's test cord (Diagram K 1000) as follows:—

(a) Throw the "subscriber's battery and Call Exchange Cut-off" key (No. 4) and keep this thrown throughout the series of tests. The object of this operation is to prevent inadvertent actuation of P.B.X. indicators during the tests.

(b) Insert the test plug into the multiple jack, throw the "Voltmeter" key (No. 6) and note, from the deflection, whether the insulation of the "B" line is satisfactory.

(c) With key No. 6 thrown, throw the "Reversing" key (No. 7), and note (i) that the voltmeter needle gives a momentary "kick," proving the continuity of the circuit, (ii) that the steady deflection of the needle is not above the allowable maximum, proving that the insulation of the "A" line is satisfactory.

(d) With keys No. 6 and 7 thrown, throw the "Earthing" key (No. 8), and observe that the deflection is below the assigned limit, thus proving that the insulation between the "A" and "B" lines is satisfactory.

At certain older types of exchanges to which subscribers with "B" line-fed P.B.X. installations are connected, a correct insulation test of the Exchange lines terminating on such apparatus can be made only in conjunction with an officer at the P.B.X., who will insert a disconnecting plug in the night jack on the exchange line under test. Where the number of such installations is small, a numerical list is prepared for the guidance of the testing telephonist.

The testing of subscribers' P.B.X. circuits over which accumulators are charged from the main exchange battery is undertaken by the Engineering Staff, and the testing telephonist is duly notified to omit these cases.

At exchanges where a testing telephonist's position is not provided, the insulation tests are carried out by the Engineering Staff from the test desk.

**Test of Ringing Keys on Manual Ringing Positions.—***Typical Diagram K 201.*—A test is made of all keys on positions with manual ringing keys to verify that the travelling springs break contact before making on ringing contacts when key is thrown to the ringing position.

A supervisor should be asked to listen on her telephone set, then each cord circuit should be tested as follows:—

(a) Insert the *answering* plug of first cord circuit into jack of supervisor's line.

(b) Move ringing key handle slowly into ringing position.

If the ringing or a loud click is heard in the supervisor's receiver, one or both of the main springs of the ringing key is

making on the outer or ringing contacts before breaking from the inner contacts; the ringing key, therefore, requires adjustment.

#### **Tests of Subscribers' and Outgoing Junction Multiple.—**

*Typical Diagram K 101.*—A continuity test is made of the subscribers' and outgoing junction multiple jacks by means of Tester No. 24 (Diagram K 1711). It will be noticed that the buzzer on the test box cannot operate unless the circuits of the tip, ring and sleeve connexions between the two testing plugs are complete. As the ring connexion is the last to make contact when plug is being inserted, the buzzer cannot operate until both plugs are fully inserted in the jacks. The test does not cover contact and earth faults, as faults of this nature on the tip or ring conductors show up under ordinary working conditions, whilst a separate test for contact on the sleeve circuits is described later.

The connexions of the Tester are arranged so as to prevent indicators at subscribers' offices being actuated when the tests are being carried out.

Each of the two officers carrying out the test has a plug connected to the box by a cord of sufficient length to cover a complete section of the multiple.

*Jack to Jack Test.*—Insert the two testing plugs simultaneously into adjacent multiple jacks of the line under test, and give a slight downward pressure to each plug to ascertain if the jack springs need adjustment. The continuity of the circuit from jack to jack is proved by the actuation of the buzzer.

When a complete section of the multiple has been tested in this way, the next section should be similarly dealt with, and so on until the whole multiple has been tested.

*End to End Test.*—In most cases it will be necessary to use a spare multiple circuit for the purpose of the end to end test. One plug of Tester No. 24 will be inserted into a jack of the line under test at one end of the multiple, and the other plug of the Tester into a spare multiple jack in the same section. One plug of a double plug-ended cord will then be inserted and retained throughout the test in a jack of the selected spare line at the other end of the switchboard, and the other plug into the multiple jack of each line under test at the same section.

When the multiple is divided (*e.g.*, between the A and B Boards), the test is made between the extreme ends of the two portions in order that the continuity of each circuit through the I.D.F. may be verified.

**Contact Test of Sleeve Connexions of Jacks** (Diagram K 1701 A).—In addition to the continuity tests of the multiple previously described, a circuit has been designed for testing sleeve circuits to guard against faults which may cause false operations

of subscribers' meters. The principle of the circuit is the application of the Wheatstone Bridge test. Relay X is operated when the Bridge is thrown out of balance by a fault on the third conductor.

The plug is inserted into the subscriber's multiple jack to be tested. If the line is disengaged and the third conductor circuit in order, a tone will be heard in the receiver and the lamp will not glow. If the line is engaged the lamp will glow and no tone will be heard.

Faults which may arise include:—

- (1) Two sleeves in contact.
- (2) Moderately high resistance on sleeve circuit.
- (3) High resistance or disconnected sleeve circuit.
- (4) Subscriber's meter adjusted too sensitively.
- (5) Full earth on sleeve circuit.
- (6) Disconnected earth, or battery on subscriber's A and B lines, or short-circuited line, assuming the line has not been plugged up for the fault at the exchange test position.

These faults will be indicated by no tone or no tone and glowing of lamp. Particulars of the circuit conditions are shown in the letterpress accompanying Loose Leaf Diagram K 1701 A.

**Test of Subscribers' Meters** (Diagram K 101).—A test of all subscribers' meters is made periodically by verifying the registration of 10 calls on each meter.

A circuit between the switchboard and the meter rack is terminated on an instrument jack at the latter point so that the two telephonists making the test can be in constant communication with each other.

*At small exchanges* the test is made by a telephonist at an "A" position, who registers 10 calls on the line under test by means of an ordinary cord circuit meter key, whilst another telephonist, stationed at the meter rack, watches the operation of the meter under test to see that the 10 calls are correctly recorded.

*At large exchanges* a special circuit is installed for testing subscribers' meters. This arrangement automatically registers 10 calls when a plug is inserted in the jack of the line under test, thus avoiding the tiring and tedious operation of recording manually 10 calls on each circuit tested. The connexions of the automatic testing circuit are shown in Diagram K 1709 A (C.B. 1029 K.).

The method of carrying out the test is as follows:—

The answering plug of an ordinary "A" position cord circuit is inserted into jack *RT/Ans* and the corresponding calling plug into a jack connected to the line to the meter rack. The relevant cord circuit key is placed in the speaking position.



The test plug *RT* (*Reg. Test*) is inserted into the subscribers' multiple jack if the line is disengaged.

A contact between two subscribers' sleeve circuits will cause Relay "M" to operate at about twice its normal speed.

If a line under test is engaged the lamp will continue to glow because the relay *Q* does not restore.

It is important that the effective meter, which is mounted in a spare panel on the test and plugging up position, should be properly adjusted so as not to operate before the shunt winding of the subscriber's meter is in circuit.

The operation of the circuit is as follows:—

Relays *Q* and *P* are slow to release. The insertion of the plug *RT* into the jack causes relay *Q* to operate. The operation of *Q* completes a circuit through relay *R*, lamp, 150 $\Omega$  resistance, 30-volt battery, earth. The operation of *R* connects the sleeve circuit of *RT/A* to that of *RT* *via* the relay *H*. This causes the subscriber's cut-off relay to operate. *H* also operates. The operation of the cut-off relay causes *Q* to restore. *R* restores in turn and the lamp ceases to glow. Relay *Q* being "slow release" does not restore until relay *L* is operated. The operation of *H* causes *L* to operate. At, and after, this stage, relays *Q* and *R* remain normal.

The operation of *L* causes *M* to operate, the circuit being completed *via* top contact of *R*, left-hand contact of *L*, resting contact of *P*, relay *M*, 30-volt battery, earth. The operation of relay *M* causes *N* to operate. On the operation of relay *N* the 30-volt battery is connected *via* the effective meter *O* in series with the 47 $\Omega$  relay *H* to the sleeve circuit of *RT*. The current through this circuit is not sufficient to operate the effective meter *O* but it is now sufficient to operate the subscriber's meter which, in operating, shunts the 500 $\Omega$  winding with a 40 $\Omega$  resistance. The current in the circuit is, therefore, sufficiently increased to permit the effective meter to operate. One call is thus recorded on the subscriber's and the effective meters respectively. The operation of meter *O* causes the slow to release relay *P* to operate and disconnect the circuit through relay *M* causing it to restore. When *M* restores, the circuit through relay *N*, meter *O* and relay *P* is disconnected and these relays are, therefore, de-energised. When relay *P* restores, the circuit through *M* is again completed and the operations previously described are repeated until the relay *M* is operated for the **eleventh** time, when the contact *X* is broken before the contact *Y* is made. The cycle of operations ceases and cannot be restarted without first withdrawing the plug from the subscriber's jack and inserting it again.

It is sometimes necessary to test specially subscribers' meters to prove the correct operation of the change over cog. For this purpose continuous operation is desirable. To effect this the key

is depressed before plug *RT* is inserted. This causes relay *V* to operate, which places a short-circuit across the contact *X*. The circuit then continues to operate until the plug is withdrawn.

A special circuit is provided for testing the correct functioning of the routine test circuit. This is self explanatory.

Each time relay *P* operates a tone is connected to the cord circuit and line on which the testing officers are listening, and affords an indication that the testing equipment is functioning.

Where any doubt exists as to the accuracy of the reading of the subscriber's meter under test, the test should be repeated before passing on to the next circuit.

The number of tests made on each meter and details of the faults which come to light as the result of the routine test are recorded on a form provided for that purpose.

**Test of Fire and other Emergency Equipment and Circuits.**—Tests of these circuits are made at suitable times of the day or night, as determined locally.

## SECTION II.

### ROUTINE TESTS MADE AT C.B. EXCHANGES BY THE ENGINEERING STAFF, AND THE APPARATUS USED.

#### GENERAL NOTES.

Many of the tests described in Section I, particularly those in connexion with cord circuits, may be regarded as tests of the circuit conditions for general faults that are likely to occur due to wear and tear under ordinary working conditions, *e.g.*, intermittent and total disconnexions, etc. In addition to tests of this kind, it is necessary to subject the equipment to further tests of a more stringent nature to ensure that not only are the circuit conductors in order, but that all parts of the equipment are maintained in such a state of adjustment that they will operate satisfactorily under the most severe conditions that may arise in practice.

For this purpose testers are made up in portable form so as to facilitate the testing of the various portions of the equipment.

A number of such testers is supplied to meet the needs of the differing conditions existing in the various types of exchanges but the principles underlying their operation are similar throughout and, for this reason, only one tester will be dealt with in detail, *viz.* :—

Tester No. 28c (C.B. No. 1, 22-volt system), Loose Leaf Diagram K 1708 A.

The following testers are identical with No. 28c in the method of operation :—

No. 28a (C.B. No. 10, 22-volt system), Loose Leaf  
Diagram K 1708 A.

No. 28b (C.B. No. 10, 40-volt system), Loose Leaf  
Diagram K 1710 A.

No. 28d (C.B. No. 1, 40-volt system), Loose Leaf  
Diagram K 1710 A.

The following tests are provided for by means of these testers :—

Cord Circuits on Subscribers' Positions.

Cord Circuits on Plug-ended Junction Positions.

Cord Circuits on Jack-ended Junction Positions.

Cord Circuits on Jack-ended Trunk Positions.

Cord Circuits on Information Desks.

Cord Circuits on Testing Telephonist's Positions.

Calling Equipments on Subscribers' Circuits.

Calling Equipments on Jack-ended Junctions.

Ringling Resistance Lamps.

The method of carrying out the various typical tests on a 22-volt system is given in the following schedules.

To appreciate fully the nature of the test applied in each case, it is advantageous to prepare a sketch illustrating the connexions of that portion of the tester which is brought into operation and to consider it in conjunction with the diagram of the particular circuit under test.

As an illustration of this method, Fig. 1 has been prepared to show diagrammatically the full circuit conditions when testing a jack-ended junction cord circuit wired in accordance with Loose Leaf Diagram K 204.

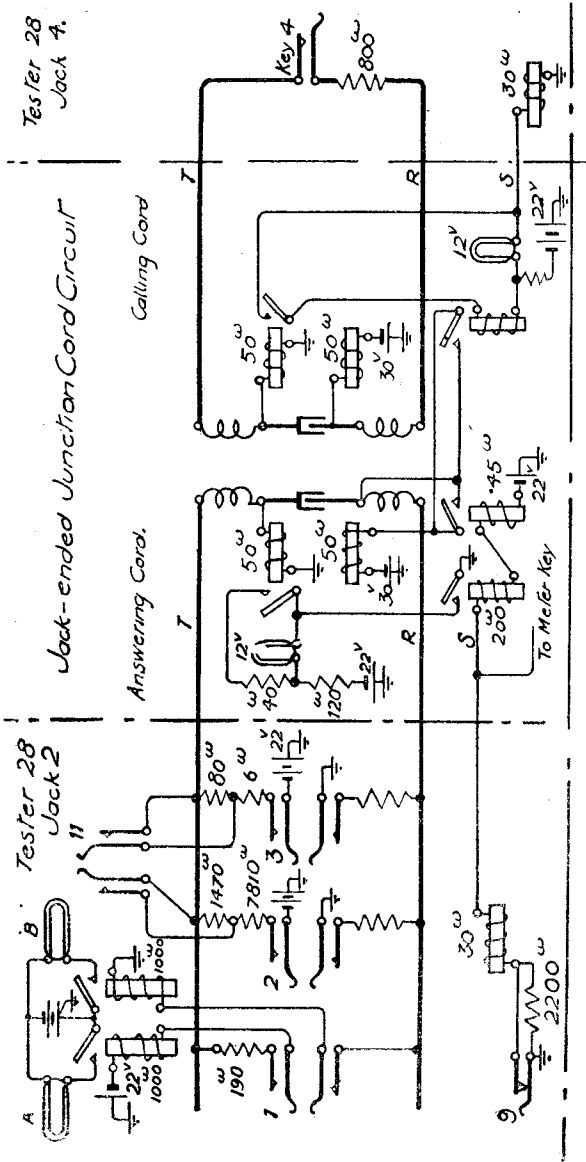

Tester 28  
Jack 2.

Lock-ended Junction Cord Circuit

Answering Cord.

Calling Cord

To Meter Key

A

Tester 28  
Jack 2

B

1

2

3

4

5

6

7

8

9

10

11

T

T

T

R

R

R

Key 4

30Ω

800Ω

12V

50Ω

50Ω

30V

22V

40Ω

120Ω

50Ω

200Ω

45Ω

22V

30Ω

2200Ω

30Ω

1000

190

1470

7810

6

80

22

30

45

22

30

45

22

30

45

22

30

45

22

30

45

22

30

45

22

30

45

22

30

45

22

30

45

22

30

45

22

30

45

22

30

45

22

30

45

22

30

45

22

30

45

22

30

45

22

30

45

22

30

45

22

30

45

22

30

45

22

30

45

22

30

45

22

30

45

22

30

45

22

30

45

22

30

45

22

30

45

22

30

45

22

30

45

22

30

45

22

30

45

22

30

45

22

30

45

22

30

45

SCHEDULE OF OPERATIONS WHEN USING TESTER No. 28C.

**All keys referred to in a specific test should be restored to their normal position before commencing the next test.**

Circuit under test and general instructions relating to test.	Test for	Keys to be operated, etc.	Result of test if apparatus or circuit is clear of faults.
<b>“ A ” Position and Information Desk Cord Circuits. (See Diagram K 201.)</b>			
<i>Answering and Calling Cords:</i> —	(a) Continuity of sleeve circuit.	All keys normal.	Supervisory lamp glows.
Insert battery plug into battery jack on section.	(b) Operation of supervisory relay and absence of cord reversal.	No. 1 (3 times).	Supervisory lamp darkened. Tester lamps A and B glow 3 times.
Insert plug of cord circuit under test into Jack 2.	(c) Release of supervisory relay after saturation.	Throw key 2 and operate key 3 approximately three times a second.	Supervisory lamp glows each time key 3 is restored.

Circuit under test and general instructions relating to test.	Test for	Keys to be operated, etc.	Result of test if apparatus or circuit is clear of faults.
<b>Cord Circuits associated with Prepayment C.C.E. Circuits.</b>			
<i>Answering and Calling Cords</i> :—			
Insert battery plug into battery jack on section. Insert plug of circuit under test in Jack No. 2.	(a) Continuity of sleeve circuit.	All keys normal.	Supervisory lamp glows.
Insert battery plug into battery jack on section.	(b) Operation of supervisory relay and absence of cord reversal.	No. 1 (3 times).	Supervisory lamp darkens. Tester lamps A and B glow 3 times.
Insert plug of circuit under test in Jack No. 2.	(c) Release of supervisory relay after saturation.	Throw key 2 and operate approximately 3 times a second.	Supervisory lamp glows each time key 3 is restored.
Battery plug to remain in battery jack ; Ans. plug in Jack No. 2.	(d) Reversal of current in Ans. cord when connection completed.	No. 1.	Tester lamps glow ; supervisory lamp darkens.
(e) Ditto.		No. 1 and calling plug in jack No. 4.	Tester lamps A and B extinguished ; supervisory lamps glow.

Circuit under test and general instructions relating to test.	Test for	Keys to be operated, etc.	Result of test if apparatus or circuit is clear of faults.
<b>Jack-ended Junction Position Cord Circuits.</b> (See Diagram K 204 and Fig. 1.)			
<i>Answering Cords:</i> —	Supervisory lamp glows.		
Insert battery plug into battery jack on section.	(a) Continuity of sleeve circuit.	All keys normal.	Supervisory lamp glows.
Insert answering plug into Jack 2.	(b) Operation of supervisory relay and absence of cord reversal.	No. 1 (3 times).	Supervisory lamp darkened. Tester lamps A and B glow 3 times.
	(c) Release of supervisory relay after saturation.	Throw keys 2 and 11 and operate key 3 approximately three times a second.	Supervisory lamp glows each time key 3 is restored.
	(d) Operation of low resistance sleeve relay.	Throw key 1 and operate key 9 two or three times.	Tester lamp "B" darkened each time key 9 is operated.

Circuit under test and general instructions relating to test.	Test for	Keys to be operated, etc.	Result of test if apparatus or circuit is clear of faults.
<p><i>Calling Cords</i> :—</p> <p>Insert battery plug into battery jack on section. Insert calling plug into Jack 2.</p>	<p>(a) Continuity of sleeve circuit.</p> <p>(b) Operation of supervisory relay and absence of cord reversal.</p>	<p>All keys normal.</p> <p>No. 1 (3 times).</p>	<p>Supervisory lamp glows.</p> <p>Supervisory lamp darkened. Tester lamps A and B glow 3 times.</p>
<p><i>Answering and Calling Cord</i></p> <p>Insert battery plug into battery jack on section. Insert answering plug into Jack 2. Insert calling plug into Jack 4.</p>	<p>(c) Release of supervisory relay after saturation.</p> <p>(a) Operation of "Through Signalling" relay.</p>	<p>Throw keys 2 and 11 and operate key 3 approximately three times a second.</p> <p>Throw keys 1 and 9 and operate key 4 approximately three times a second.</p>	<p>Supervisory lamp glows each time key 3 is restored.</p> <p>Calling supervisory lamp glows and tester lamp "B" darkens each time key 4 is restored.</p>



Circuit under test and general instructions relating to test.	Test for	Keys to be operated, etc.	Result of test if apparatus or circuit is clear of faults.
<p>Connect Jack 9 to any jack on section to which a bell is connected. Insert battery plug into battery jack on section. Insert calling plug into Jack 7 (for ordinary and "X" ringing keys) or Jack 8 (for "Y" ringing keys).</p>	<p>(a) Ringing resistance lamp on position.</p>	<p>All tester keys normal. Depress Cord Circuit ringing key or keys.</p>	<p>Bell rings. Tester lamp "RR" does not glow. (Note.—The glowing of the lamp "RR" indicates a fault which should be given prompt attention.)</p>

**Ringling Resistance Lamps.** (See Diagram K 1905, Fig. 1.)

Circuit under test and general instructions relating to test.	Test for	Keys to be operated, etc.	Result of test if apparatus or circuit is clear of faults.
<b>Plug Ended O. W. Junctions from C.B. (See Diagram K 301.)</b>			
<p>Insert battery plug into battery jack on section and jack 9 to ringing test jack No. 1 on section (K 1702). Ask "A" telephonist at o/g end to insert "A" position plug into jack of junction to be tested, and listen on circuit. Connect telephone set to tester.</p>	<p>(a) Continuity of sleeve lamp and junction line relay circuits.</p>	<p>All keys normal.</p>	<p>Junction lamp glows on insertion of plug at outgoing end.</p>
<p>Insert junction plug into jack 2 of tester.</p>	<p>(b) Continuity of lamp shunt and ringing circuits.</p>	<p>All keys normal.</p>	<p>Junction lamp darkens. Switchboard bell rings intermittently.</p>
<p>Ditto.</p>	<p>(c) Tripping ringing by generator current. (For adjustment tests of the tripping relay, battery tests should be adopted).</p>	<p>No. 8 (where "B" line ringing is adopted throw reversing key No. 10).</p>	<p>Bell ceases to ring and junction lamp remains darkened.</p>

Circuit under test and general instructions relating to test.	Test for	Keys to be operated, etc.	Result of test if apparatus or circuit is clear of faults.
<p>Withdraw and reinsert junction plug into jack 2 of tester.</p>	<p><b>Plug Ended O. W. Junctions from C. B. —contd.</b></p> <p>(d) Tripping ringing by battery current, and continuity of "B" line of ringing circuit, or if "B" line ringing adopted, continuity of "A" line ringing circuit.</p>	<p>Depress and restore key 7 during the silent period. (<i>Note.</i>—It is important that these two operations should be completed during the silent interval.) If "B" line ringing adopted throw reversing key No. 10.</p>	<p>Switchboard bell rings intermittently when junction plug is re-inserted, then fails to ring after key 7 is operated and released. Tester lamp "B" glows momentarily.</p>
<p>Junction plug in jack 2 of tester.</p>	<p>(e) Operation of supervisory relay. Continuity of junction circuit to o/g end. Absence of cord reversal.</p>	<p>Operate key 1 three times and then throw key 6 to speak to distant "A" telephonist.</p>	<p>Supervisory lamp at o/g end flashes three times and remains darkened when key is operated. Tester lamps "A" and "B" glow three times. Note that transmission is good.</p>
<p>Junction plug in jack 2 of tester.</p>	<p>(f) Operation of supervisory relay after saturation.</p>	<p>Throw key 2 and operate key 3 three times, and then throw key 6.</p>	<p>Supervisory lamp at o/g end flashes 3 times and remains darkened when key 6 is operated. Note that transmission is good.</p>

Circuit under test and general instructions relating to test.	Test for	Keys to be operated, etc.	Result of test if apparatus or circuit is clear of faults.
Ask telephonist at o/g end to withdraw and re-insert plug.	(g) Operation of junction line relay.	<b>Plug Ended O.W. Junctions from C.B.—cont'd.</b> No. 6.	Junction lamp glows when plug withdrawn at o/g end and darkened when plug re-inserted.
<b>Supervisory Test and Plugging-up Cord Circuits.</b> (Diagram K 1004.)			
Insert battery plug into battery jack on section.	(a) Continuity of sleeve and supervisory lamp circuits.	All keys normal.	Cord circuit lamp glows.
Insert plug of cord circuit under test into jack 5. Cord circuit keys to be in normal position.	(b) Operation of 500 $\Omega$ plus 500 $\Omega$ relay and absence of cord reversal.	Key No. 1.	Cord circuit lamp extinguished. Tester lamps "A" and "B" glow.
	(c) Retention of 500 $\Omega$ plus 500 $\Omega$ relay through 14,000 $\Omega$ .	Throw key 5 and operate key 1 two or three times.	Cord circuit lamp remains extinguished. Tester lamps "A" and "B" glow when key 1 is operated.
	(d) Operation of 500 $\Omega$ plus 500 $\Omega$ relay after saturation.	Throw key 2 and operate key 3 approximately three times a second.	Cord circuit lamp glows each time key 3 is restored.

Circuit under test and general instructions relating to test.	Test or	Keys to be operated, etc.	Result of test if apparatus or circuit is clear of faults.
<b>Supervisory Test and Plugging-up Cord Circuits.—contd.</b>			
Throw "reverse" key on circuit under test.	(e) Connexions of cord "reverse" key.	No. 1.	Cord circuit lamp glows. Tester lamps "A" and "B" extinguished.
Throw "disconnect" key on circuit under test.	(f) Connexions of cord circuit "disconnect" key.	Operate key 1 two or three times.	Cord circuit lamp flashes. Tester lamps "A" and "B" glow.
With plugging-up cord circuit plug in tester jack 5 and "disconnect" key restored. Insert an ordinary "A" position cord circuit plug into break-jack of circuit under test.	(g) Connexions of cord circuit break jack.	No. 1.	Plugging-up cord circuit lamp extinguished. Tester lamps "A" and "B" glow. "A" position supervisory lamp glows.

Circuit under test and general instructions relating to test.	Test for	Keys to be operated, etc.	Result of test if apparatus or circuit is clear of faults.
Insert battery plug into battery jack on section. Connect circuit under test to jack 1.	(a) Operation of 200 $\Omega$ calling relay.	No. 1.	Tester lamp "A" glows. Calling lamp on section glows.
	(b) Release of calling relay after saturation.	No. 2 and 11. Operate No. 3 several times.	Calling lamp glows when key No. 3 is operated and is extinguished when key restored.
	(c) Operation of 2,000 $\Omega$ cut-off relay.	No. 1. Operate No. 4 several times. (Use key No. 11 here only on 40 volt systems.)	Calling lamp and tester lamp "A" glow each time key No. 4 is restored.

**Jack-Ended Junction Calling Equipment. (Diagram K. 600.)**

## TEST OF RESISTANCE LAMPS ON P.B.X. POWER-RINGING LEADS.

(LOOSE LEAF DIAGRAM K 1703.)

To verify that these lamps are not short-circuited, a special test is made, using for the purpose the test circuit shown in the above-mentioned diagram. One side of the test lamp is connected to earth and the other to a flexible lead, which is used to tap on to the arrester of each working ringing lead. If the resistance lamp is in order, a dull red glow will be observed on the test lamp, but a bright glow will be observed if the resistance lamp is short-circuited.

### TEST OF SUPERVISORY AND PILOT LAMP CAPS.

To ensure that the metal portions of these lamp caps are not in contact with the negative pole of the exchange battery owing to the lamp being inserted in the jack in such a position that the metal connexion plates of the lamp make contact with the framework of the lamp jack, the following test is carried out. Using a Headgear Receiver, which is earthed on one side by connecting one of the clips to the ironwork of the section, each lamp cap is tapped with the other clip. If a fault exists a click will be heard in the Headgear Receiver.

### ROUTINE TEST FAULT RECORDS AND RETURNS.

The methods of reporting, recording and summarising routine test faults are contained in T.I. XXVII, Part 2. This instruction also gives particulars relative to the plant to be tested, by whom the tests should be made, *i.e.*, traffic or engineering staff or both, and the frequency of the tests.

### APPARATUS USED BY MAINTENANCE STAFF FOR LOCALISING FAULTS.

In addition to the Testers already referred to, which can, of course, be used to a considerable extent for localising faults as well as for carrying out routine tests, a number of other testing appliances have been designed to facilitate the work in connexion with the localisation and clearance of faults occurring on the exchange equipment. A brief description of each of the standard arrangements at present in use in C.B. exchanges follows:—

*Tester Nos. 5 and 5a, for Testing Subscribers' Calling Equipments (Diagram K 1705 A).*

This is a pocket-size tester equipped with three lamps and three keys, commonly known as the three-lamp set. It is used for determining the nature and location of faults occurring upon subscribers' exchange equipment. It has been re-designed to render it serviceable for use at C.B. exchanges having the line relay in either the "A" or "B" line. A resistance has been added to prevent the burning out of the 12 volt lamp. For use with circuits having the line relay in the "A" line, this resistance should be short-circuited.

The operation of the tester will be clearly understood from the diagram.

The use of this tester on a subscriber's line circuit frequently causes the subscriber to answer, since, when the tester keys are operated, the condenser in the subscriber's bell or indicator circuit is discharged or charged as the case may be. For this reason its use after ordinary working hours is not advisable, and Tester No. 28 or No. 28a should be used on such occasions.

#### *Tester No. 6 (Diagram K 1706).*

This testing instrument, known as the drop-of-potential set, is used for localising faults in the subscribers' multiple at C.B. exchanges.

The principle underlying the operation of the tester is that when a telephone receiver is tapped across two points of a wire in which a current is flowing a "click" is heard, due to the difference of potential between the two points to which the receiver is connected. Use is made of this principle to determine the jack or portion of wiring at fault in a multiple.

It will be obvious, therefore, that in making a succession of taps at different points on a defective circuit, a click will be heard in each instance where a current is flowing, and there will be silence in the receiver when a section of the circuit is embraced by the two points of contact between which a current is not flowing.

The receiver, being very sensitive, will give an audible click even when the potential difference applied to its terminals is very small.

The keys on the tester permit the receiver to be connected across the tip, ring, or sleeve wires as required, and the diagram is sufficiently self-explanatory as regards actual testing operations.

An intelligent use of this tester in the case of a fault upon a multiple will obviate the removal and examination of all the multiple jacks except that on which the fault exists.

#### *Tester No. 40.*

This tester consists of two lamp jacks contained in an insulating fibre tube, the jacks being fitted to accommodate lamps of the voltage desired, at the respective ends of the tube. The tester is filled with a removable insulated contact spike which, when not in use, is housed on the body of the tester by means of two spring steel clips. One lamp is for detection purposes and the other for illumination. The tester is fitted with a reversing Key in association with a twin conductor flexible cord. Suitable spring clips are fitted to the ends of the cords for the purpose of making connexion to battery and earth respectively. The tester is used for point to point testing on exchange equipment and the method of application needs no further explanation. The circuit details are given in Loose Leaf Diagram K 1719. The tester supersedes Tester No. 8.



*Localisation Lamps (Diagram K 1006).*

At large exchanges a special plugging-up circuit, in accordance with the diagram referred to, is provided to facilitate the localisation of exchange faults. The circuit is a modification of the plugging-up circuits shown in Diagram K 1004, additional lamps being fitted in prominent positions in the switch-room and test-room so as to be readily seen by workmen engaged in localising faults.

The circuit is fitted on the testing telephonist's position. The key associated with the cord can be set for various classes of faults as in the case of ordinary plugging-up cords.

When the key is correctly set in accordance with the nature of the fault on the circuit under test, the lamps do not glow so long as the fault persists, but are illuminated immediately the fault disappears. The circuit is obviously of special value in dealing with faults of an intermittent nature.

It will be seen from the diagram that the  $500\Omega + 500\Omega$  relay is energised whilst the fault exists, thus preventing the operation of the differential relay controlling the lamps until the fault is cleared.

*Tester No. 17 (Diagram T 104).*

This tester was used for the testing of switchboard cords away from the switchboard. It has been superseded by Tester No. 39.

*Tester No. 45 (Diagram K 1717).*

This tester is designed for the use of the cord repair staff in C.B. exchanges where cord repair tubes are fitted and provides means of testing for continuity and reversals. The diagram is self-explanatory.

*Tester No. 39 (Diagram T 109).*

This tester is for testing cords at the repair bench and for testing multiple cables and jacks on new work (before cross-connecting) in exchanges where the line and cut-off relays are associated with the answering jacks.

The diagram is self-explanatory.

*Testers Nos. 89 and 89A.*

These testers are for use by the Traffic Staff for routine testing the calling equipments associated with prepayment C.C.B. circuits at C.B. Manual Exchanges. Testers No. 89 are for use at 22-volt exchanges and Testers No. 89A at 40-volt exchanges.

The method of making the test is as follows:—

(a) To test for “ Normal call ” conditions, insert the black plug into a battery jack and the red plug into a jack of the line to be tested. If the circuit is in order the line lamp will glow continuously.

(b) To test Emergency Call conditions, depress the button fitted in the tester. The lamp should then flash intermittently.

(c) To restore the circuit to normal, remove the red plug and replace with a plug of an ordinary cord circuit.

#### *Examination of Testers.*

It is **important** that **periodical verification** of the **resistances** used in the standard testers should be made. This will be done usually by the exchange maintenance officer, using Detector No. 2 or No. 4 and two or three primary cells, or other reliable method, and applying the ordinary tests for resistance when various test keys are depressed. The values obtained should be checked against the theoretical values shown in the relevant diagrams and where the difference is greater than 5 per cent. the particular coils concerned should be changed.

# LIST OF Technical Pamphlets for Workmen

(Continued)

## GROUP D—*continued*

20. Superposed Circuits. Transformers. Bridging Coils and Retardation Coils.
21. Call Offices.
22. Units. Amplifying. (*Not on Sale.*)

## GROUP E

1. Automatic Telephony: Step-by-Step Systems.
2. Automatic Telephony: Coded Call Indicator (C.C.I.) Working.
3. Automatic Telephony: Keysending "B" positions.

## GROUP F

1. Subscribers' Apparatus.—Common Battery System.
2. Subscribers' Apparatus, C.B.S. Part I—C.B.S. No. 1 System.
3. Subscribers' Apparatus. Magneto.
4. Private Branch Exchanges—Common Battery System.
5. Private Branch Exchange—C.B. Multiple No. 9.
6. Private Branch Exchanges—Magneto.
7. House Telephone Systems.
8. Wiring of Subscribers' Premises.

## GROUP G

1. Maintenance of Secondary Cells.
2. Power Plant for Telegraph and Telephone Purposes.
3. Maintenance of Power Plant for Telegraph and Telephone Purposes.
4. Telegraph Battery Power Distribution Boards.

## GROUP H

1. Open Line Construction, Part I.
2. Open Line Construction, Part II.
3. Open Line Maintenance.
4. Underground Construction, Part I—Conduits.
5. Underground Construction, Part II—Cables.
6. Underground Maintenance.
7. Cable Balancing.
8. Power Circuit Guarding.
9. Electrolytic Action on Cable Sheaths, etc.
10. Constants of Conductors used for Telegraph and Telephone Purposes.

## GROUP I

1. Submarine Cables.

## GROUP K

1. Electric Lighting.
2. Lifts.
3. Heating Systems.
4. Pneumatic Tube Systems.
5. Gas and Petrol Engines.