

Crown Copyright Reserved

PW-A 6

Post Office Engineering Department

**TECHNICAL PAMPHLETS
FOR WORKMEN**

Subject
**Measuring and Testing
Instruments**

*ENGINEER-IN-CHIEF'S OFFICE
August, 1934*

LIST OF Technical Pamphlets for Workmen

GROUP A.

1. Magnetism and Electricity.
2. Primary Batteries.
3. Technical Terms.
4. Test Boards.
5. Protective Fittings.
6. Measuring and Testing Instruments.
7. Sensitivity of Apparatus.
8. Standard List of Terms and Definitions used in Telegraphy and Telephony. (*Not on sale.*)

GROUP B.

1. Elementary Principles of Telegraphy and Systems up to Morse Duplex.
2. Telegraph Concentrators.
3. Wheatstone System. Morse Keyboard Perforators.
4. Quadruplex, Quadruplex Repeated Circuits and Telegraph Repeaters, Simplex and Duplex.
5. Hughes Type-printing Telegraph.
6. Baudot Multiplex Type-printing System.
7. Western Electric Duplex Multiplex. Murray Duplex Multiplex. Siemens and Halske Automatic Type-printing System.
8. Fire Alarm Systems.

GROUP C.

1. Wireless Transmission and Reception.
2. Interference with Reception of Broadcasting.

GROUP D.

1. Elementary Principles of Telephony
2. Telephone Transmission. "Loading." Telephone Repeaters and Thermionic Valves.
3. Principles of Telephone Exchange Signalling.
4. Magneto Exchanges—Non-Multiple Type.
5. Magneto Exchanges—Multiple Type.
6. C.B.S. No. 1 Exchanges—Non-Multiple Type.
7. C.B.S. Exchanges—Multiple Type.
8. C.B. Exchanges—No. 9 Type.
9. C.B. Exchanges—No. 10 Type.
10. C.B. Exchanges—No. 12 Type.
11. C.B. Exchanges—22 Volts.
12. C.B. Exchanges—40 Volts.
13. Trunk Telephone Exchanges.
14. Maintenance of Manual Telephone Exchanges.
15. Telephone Testing Equipment.
16. Routine Testing for Manual Telephone Exchanges.
17. Internal Cabling and Wiring.
18. Distribution Cases, M.D.F. and I.D.F.
19. Cord Repairs.
20. Superposed Circuits. Transformers. Bridging Coils and Retardation Coils.
21. Call Offices.

[Continued on Page iii of Cover.]

MEASURING AND TESTING INSTRUMENTS (A6)

Diagram T.102 (16 sheets) and Diagrams T.116-131 in the Post Office Loose Leaf series of diagrams are essential to the study of this pamphlet and are reproduced at the end.

The following pamphlets are of kindred interest :

- A. 1. Magnetism and Electricity.**
- A. 3. Technical Terms.**
- A. 7. Sensitivity of Apparatus.**

The following Post Office Technical Instruction is also of interest :

T.I.IV. Maintenance Testing.

MEASURING AND TESTING INSTRUMENTS

TABLE OF CONTENTS.

	PAGE
MAGNETISM AND ELECTRICITY	5
SIMPLE GALVANOMETER	6
DETECTOR No. 1	7
MOVING-IRON OR GRAVITY TYPES OF MEASURING INSTRUMENTS	10
MOVING-COIL TYPES OF MEASURING INSTRUMENTS ..	11
VOLTMETERS AND AMPÈREMETERS	12
DETECTOR No. 2	18
WHEATSTONE BRIDGE	22
THE MEGGER	25
DETECTOR No. 4	27
DIAGRAM T.102 (16 sheets)	33
DIAGRAMS T.116 TO 131	49

CORRECTION SLIP TABLE

The month and year of issue is printed at the end of each amendment in the Correction Slips, and the number of the slip in which any particular amendment is issued can, therefore, be traced from the date. In the case of short corrections made in manuscript, the date of issue of the slip should be noted against the correction.

The Summary portion of the Correction Slips should be completed and affixed below in numerical order.

CORRECTION SLIP TABLE—contd.

The month and year of issue is printed at the end of each amendment in the Correction Slips, and the number of the slip in which any particular amendment is issued can, therefore, be traced from the date. In the case of short corrections made in manuscript, the date of issue of the slip should be noted against the correction.

The Summary portions of the Correction Slips should be completed and affixed below in numerical order.

MEASURING AND TESTING INSTRUMENTS

MAGNETISM.

A magnetic needle is acted upon by the earth's magnetic force, and, if freely suspended, will come to rest pointing North and South.

ELECTRICITY.

If a piece of wire, the ends of which are connected to an electric battery, be placed near to, and parallel with, the suspended magnetic needle, the needle will tend to move, and :—

(i) Increasing the battery power will increase the movement of the needle ;

(ii) Increasing the resistance of the wire will decrease the movement of the needle.

It is therefore apparent that the action of the needle is dependent upon the electrical conditions set up. These may be briefly stated as the **Electromotive Force**, or E.M.F. of the battery, measured in "**Volts**"; the **resistance** or opposition to the passage of the electricity in the wire, measured in "**Ohms**," and the **strength of the current** of electricity in the wire, measured in "**Ampères**."

These units have a definite relationship to one another, as explained in the Technical Pamphlet on Magnetism and Electricity (A.1), and the law connecting them is known as "**Ohm's**" law.

For reference purposes **Ohm's law** is given below in its abbreviated form—*i.e.* :—

$$I = \frac{E}{R}$$

Where I = strength of current in the circuit = Ampères ;

E = electromotive force of voltage of the source of power = Volts ;

R = resistance of the complete circuit = Ohms.

Knowing any two of these values, the third may readily be calculated. For example, supposing we know the values of E and I, then the resistance of the complete circuit, or R, is equal to the voltage of E divided by the value of I, thus :—

$$R = \frac{E}{I}$$

Knowing I and R, the value of E is equal to the product obtained by multiplying together the values of I and R, or :—

$$E = I \times R$$

Practical examples of the application of Ohm's law are given later.

It is customary to assume that the current in the circuit shown in Fig. 1 circulates from the cells along the external wire in a definite direction, starting from the first positive pole (terminal on carbon) through the wire in the direction of the arrows and back to the right-hand or negative pole (zinc) through the cells, and thence back to the first carbon or starting point.



Fig. 1.

SIMPLE GALVANOMETER.

Suppose we take two feet of the wire in the above circuit (Fig. 1) and hold it in a direction pointing North and South, and below the wire, but close to it, we place a small compass needle, it will be found, when the circuit is connected, that the needle moves in the direction indicated in Fig. 2, the end of the needle marked N, moving anti-clockwise.

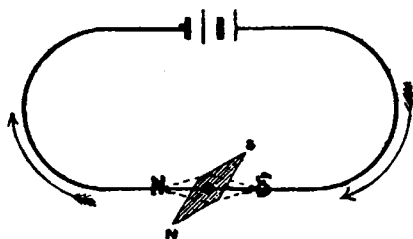

Fig. 2.

With conditions the same as in Fig. 2, except that the wires are reversed on the battery, it will be noticed that the end of the needle marked N, will now move clockwise, as shown in Fig. 3.

With current flowing as in Fig. 2, but with needle placed above the wire, the North end moves to the right.

With current flowing as in Fig. 3, but with needle placed above the wire, the North end moves towards the observer—i.e., in the opposite direction to that shown in Fig. 3.

Summarizing these experiments, we learn that :—

- (i) The direction of the current in a wire determines direction of needle movement ;

(ii) By placing the wire under the needle and maintaining the same direction of current, the needle movement is reversed.

In Fig. 4 it will be seen that the current flows from right to left in the wire over the needle and from left to right in the wire under the needle, the combined effect tending to turn the needle in the same direction. As a result, twice the turning force is applied. By increasing the number of turns of wire the turning force is increased.

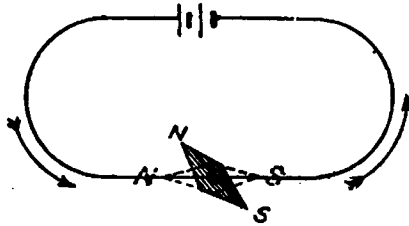

Fig. 3.

In other words, if a magnetic needle be suspended or pivoted inside a coil of insulated wire, when a current flows through the coil, the needle is deflected to the right or left, according to the direction of the current. Such an arrangement is called a simple detector, *i.e.*, an instrument designed to show the presence of an electric current in a circuit to which the detector may be connected.

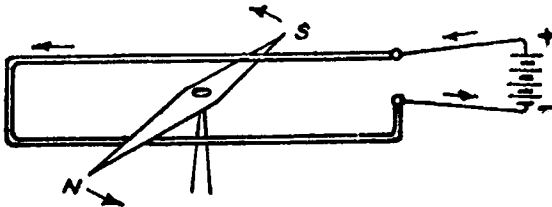

Fig. 4.

This principle is utilized in the construction of galvanometers and detectors. In some cases, the needle is arranged to move horizontally, whilst in others it moves vertically, according to the particular type of instrument concerned.

DETECTOR No. 1.

For rough testing work, a portable form of galvanometer termed a "Detector No. 1," formerly known as the Q. and I. Detector, is used by linemen. The instrument is used for such work as "tapping out" a cable to identify the various wires in the cable; for proving whether a wire is continuous

between certain points ; for proving whether a wire is in contact with any other wire in its vicinity ; for proving whether a wire is in contact with the earth, or sheathing of a cable ; for rough testing of induction coils, receivers, telephone cords, bells, etc.

In general, the Detector No. 1 is merely an instrument designed for detecting the presence of a current, but by carefully noting the values of the different deflections obtained when carrying out certain tests, it is possible to arrive at a useful conclusion about the condition of the circuit under test. As Detector No. 1 is gradually being replaced by Detector No. 2, only a brief description and explanation of the former will be given here.

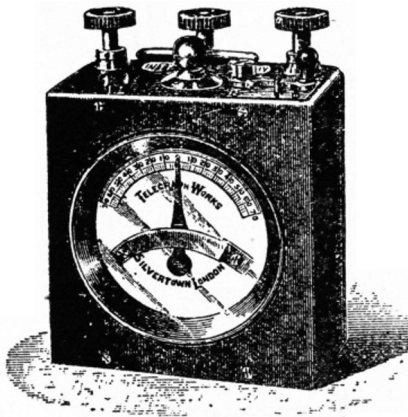

Fig. 5.

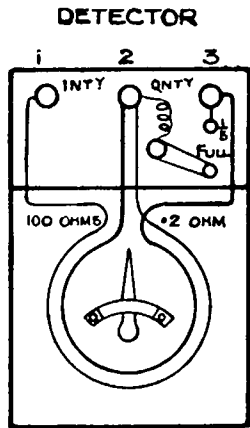

Fig. 6.

The Detector No. 1 consists of two rectangular frames mounted inside a wooden case with a circular glass front and scale marked off uniformly in divisions up to 70 (Fig. 5). Each of the rectangular frames is wound with a large number of turns of insulated copper wire, the inside ends being connected together to form one coil ; the two ends of the coil are brought out to two brass terminals on the top of the instrument, the resistance of the coils being approximately 100Ω . Another coil of thick wire and few turns (about $\frac{1}{2}\Omega$) is also wound on the frames, and one end of this coil is connected to one of the existing terminals used for the 100Ω winding, whilst the other end is connected to a third brass terminal. A photograph and diagram of the connexions are given in Figs. 5 and 6, respectively.

The terminals have been numbered for explanatory purposes, terminals 1 and 2 being used for measuring small currents up to a few milliamperes, whilst terminals 2 and 3 are used for comparatively large currents up to about 150 milliamperes.

A magnetized needle is pivoted in the centre of the rectangular frames and when a current flows in the coil, the needle tends to set itself in the direction of the magnetic lines of force produced by the current, *i.e.*, the needle moves anti-clockwise or clockwise, according to direction of current in the coil. A light non-magnetic pointer is attached to the axle which carries the needle, and this moves over the face of the scale and indicates the number of divisions or degrees movement of the inner needle. To prevent the needle from being demagnetized by excessive currents, two permanent magnets are inserted just below the lower end of the inside needle.

The deflections are not directly proportional to the strength of the current, for example, a current of 10 milliamperes through the 100 Ω coil gives a deflection of approximately 45 divisions; the current required to obtain a deflection of 15 divisions will be approximately 5 milliamperes.

By connecting the instrument in series with a standard ampèremeter, the approximate value of the currents corresponding to the various deflections may be obtained and noted for future use.

Using the low resistance coil, connected to terminals 2 and 3, a current of approximately 140 milliamperes will give 25 divisions deflection.

A **shunt** of $.05\Omega$ (1/20th Ω) is connected, via a small switch on the top of the instrument, to the low resistance winding (terminals 2 and 3) so that when the switch is on the position marked " $\frac{1}{5}$," only 1/5th of the current in the circuit under test will pass through the low-resistance winding and 4/5ths will pass through the shunt. The current through the shunt has no effect on the needle, the shunt being used only when a larger current than can be safely carried by the detector winding is to be measured.

For example, with the shunt in use, a current of 1 ampère (1,000 m.a.) in the main circuit will produce a deflection of approximately 30 divisions, 1/5th of this current, or 200 m.a. passing through the detector coil and 4/5ths, or 800 m.a., through the shunt.

Similarly a current of 3 ampères in the main circuit will produce a deflection of approximately 60 divisions.

Care should be taken not to drop the detector, as the needle may become damaged on its pivots, or the two magnets may lose some of their permanent magnetism, thereby giving a smaller deflection than before for the same value of current. Generally this detector should only be used on low voltage circuits, otherwise the coils may be burnt out by an excess current.

Horizontal Galvanometer.—A simple and sensitive instrument known as the *horizontal galvanometer*, is illustrated

in Fig. 7. The needle of this instrument is delicately mounted between jewelled bearings, and the scale is finely divided.

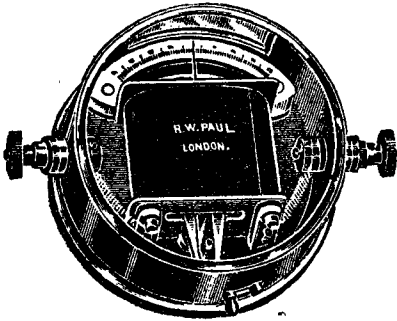

Fig. 7.—HORIZONTAL GALVANOMETER

A piece of looking-glass is fixed beside the scale under the pointer, so that when looking down on the latter the eye can be moved till the pointer and its image coincide. By this means any error, technically known as *parallax*, due to reading the scale from the pointer at an angle to the vertical is avoided.

MOVING-IRON OR GRAVITY TYPES OF MEASURING INSTRUMENTS.

In the ordinary detector, the moving system is a magnetic needle pivoted inside a coil of insulated wire. Instruments designed on a different method, and used for measuring volts and ampères, are generally used on telephone and telegraph power boards.

These instruments are constructed on the following principle:—

A coil of insulated wire through which a current is flowing will behave in the same way as a bar magnet. For instance, a small piece of soft iron attached to a length of string will be sucked within the coil when the current is flowing, but there is no force of attraction when the current is disconnected. The stronger the current the greater will be the attracting force. An increase in the number of turns will also produce a greater force of attraction if the current remains the same strength as before.

By pivoting the piece of soft iron in such a way that it is free to move towards the inside of the coil but will be restored to its normal position when a current is not flowing in the coil, it is possible to arrange for the movement of the iron to give an indication, by means of a separate pointer, of the value of the current actually passing through the coil.

The action of such an instrument depends therefore on the creation of a magnetic field when a current circulates in a fixed coil of wire. The pointer attached to the moving iron is restored to its normal position by gravity, the bottom part of the iron being slightly heavier than the top. Slight modifications of the above are adopted by different makers, but,

generally speaking, the action of the instrument is based on the principle that a piece of magnetic material will endeavour to move into the strongest part of the magnetic field of a coil of wire. To increase the effect on the movable iron, another piece of iron is fixed inside the coil.

In these instruments, as in the case of the Detector No. 1, the movement of the pointer is not directly proportional to the strength of the current in the coil, a deflection to the far end of the scale requiring less than twice the current for half way across. One advantage of the moving-iron type of instrument is that the pointer is deflected in the same direction irrespective of the direction of the current through the coil.

MOVING-COIL TYPES OF MEASURING INSTRUMENTS.

The action of this type of instrument is based on the following principle :—

Place a horseshoe magnet in a vertical position, and between the pole pieces of the magnet suspend a small coil of insulated wire, which can be connected to a battery of three or four cells, as shown in Fig. 8.

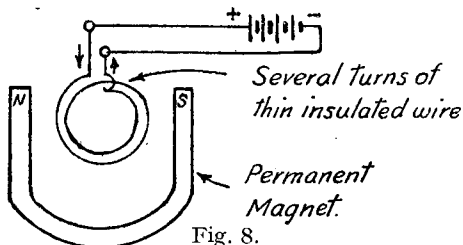

Connect up the coil to the battery and it will be noticed that the coil endeavours to place itself at right angles to its original position. Disconnect the current and the coil swings back to its normal position. Reverse the current and the coil will move in the reverse direction. Send twice the strength of current through the coil and it will move more quickly and through a greater angle than in the first case. Roughly, if the current be doubled, the coil will move through twice the angle, and so on, the movement being practically proportional to the strength of current. By increasing the number of turns for a given current, a greater movement of the coil is obtained. In other words, if the product of ampères and number of turns be increased, a greater movement is obtained with a given current, but in practice there is a limit to these on account of the size of wire and the dimensions of the frame on which the wire is wound.

The action of such an instrument depends, therefore, on the creation of a magnetic field in a movable coil of wire, this field

tending to set itself in line with the field due to a fixed powerful permanent magnet. The reason why the coil does not make a complete revolution is that the current in the coil is maintained in the same direction ; also, the twisting of the supporting wires or springs prevents the coil from moving too far.

VOLTMETERS AND AMPÈREMETERS.

A **voltmeter** is an instrument designed for measuring the electrical pressure, or difference of potential in **volts** between two points in a circuit.

An **ampèremeter**, generally termed an "**ammeter**," is for measuring the strength of current in **ampères**.

These instruments may be divided into the two general classes already described, viz. :—

- (i) Moving iron or gravity-controlled instruments.
- (ii) Moving coil instruments.

Voltmeters and ammeters of the **moving iron type** are relatively insensitive and are not so convenient for use as the more up-to-date instruments which are designed on the moving coil principle, because the pointer does not come to rest quickly.

A further disadvantage of the moving-iron type is that it cannot be used in the vicinity of motors, dynamos, electric tramway systems, etc., without affecting the accuracy of the readings to an appreciable degree.

A voltmeter of the **moving coil type** will be described in detail as that is the type now generally used. **There are two essential differences between a voltmeter and an ammeter.** In the case of the **voltmeter** the length of wire in the coil is large, and therefore the total resistance of a voltmeter is high, in order that only a very small current will be taken from the battery or circuit to which the voltmeter is connected.

The total resistance of an **ammeter** is extremely low, as the instrument is always connected directly in series in the circuit, under test, thus allowing large currents to be passed through it without appreciably increasing the resistance of the main circuit. Except with regard to the total resistance of the instruments, voltmeters and ammeters of the moving coil type are constructed in the same way, a low resistance shunt being used in order to convert a voltmeter into an ammeter. This will be better understood after the construction of the voltmeter has been described.

Voltmeters.—Inside the voltmeter case is a powerful permanent magnet, between the poles of which, but not touching the magnet, is fixed a block of soft iron. The object of this iron is to assist in producing a uniform magnetic field. A small air-gap is left between the soft-iron block and the magnet, and in this space a light rectangular frame of copper, silver or aluminium is pivoted and moves under the control of two hair-

springs in such a way that the normal position of a thin aluminium pointer attached to the frame is at zero on the voltmeter scale.

Many turns of thin insulated copper wire are wound on to the movable metal frame, and the two ends of this coil are connected to the hair-springs, and thence through resistors wound with platinoid, manganin, or other high resistance wire to the external terminals of the voltmeter.

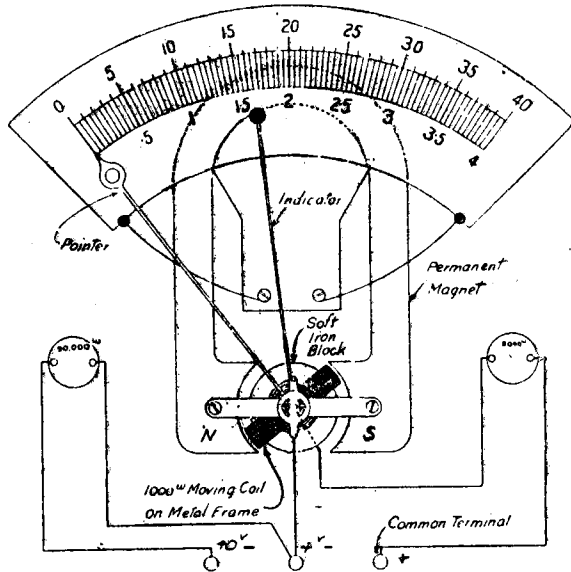

Fig. 9.

The resistors and connexions of a Weston moving-coil type of two-scale voltmeter, as used on a C.B. Exchange test desk, are shown diagrammatically in Fig. 9.

When a current passes through the 1,000 Ω voltmeter coil, a magnetic field is produced in the coil, and the latter moves in the field of the permanent magnet, until the movement is balanced by the tension of the hair-springs attached to each end of the coil; then, the coil comes to rest at a definite position on the scale, according to the value of the voltage applied to the voltmeter terminals. If a voltage of four be applied to the positive and 4-volt terminals, the pointer will move to the full limit of the scale. The same result will be obtained, by applying forty volts to the positive and the 40-volt terminals. The scale

is graduated uniformly in divisions, and the readings are made from the 4-volt or 40-volt markings, according to which terminals are in use.

It will be seen from Fig. 9 that the total current passing through the moving coil must never exceed $\frac{4 \text{ volts}}{10,000 \Omega}$, *i.e.*, 4/10ths of a **milliampère** (0.0004 amps.); **care must therefore be taken to guard against the application of voltages higher than the stated voltages on the terminals in use**, otherwise the pointer may be broken or the fine wire resistance coils be burnt out.

This type of voltmeter is constructed in such a way that the moving coil takes up its position in a very steady manner and comes to rest almost instantly after applying a voltage, in other words it is "dead-beat."

The damping of the coil in this manner is based on the following principles:—

If a closed loop of wire be placed in a strong magnetic field and made to cut the lines of force due to the magnet, a current is produced and this current circulates through the loop in such a direction that its effect is to endeavour to move it in the opposite direction to the original movement. In a simple form the loop of wire may be likened to the armature of a dynamo which is made to revolve in a magnetic field by some outside force, thus producing a current of electricity when the armature is connected to a closed electrical circuit.

In the case of the voltmeter under consideration, the coil of insulated wire is moved by virtue of the current flowing through it; the frame on which the coil is wound must travel with it, but in moving, it becomes the equivalent of a loop of wire with only one turn, and a comparatively strong current in the opposite direction to that in the coil is produced in the metal frame, with the effect stated above. The induced current in the frame only lasts whilst the frame is in motion, and when the various forces referred to are equalized, the coil comes to rest at a definite position, and the current in the frame ceases.

By using an instrument of this type, it is possible to take successive readings quickly without having to waste time waiting for the pointer to come to rest, as in the case of moving-iron types of instruments.

If it is desired **to increase the range of a voltmeter**, *i.e.*, to measure, say, twice the voltage for which the instrument is designed, it is only necessary to insert another resistance in series with the voltmeter equal in value to the existing total resistance of the voltmeter. In order to ascertain the true value of the voltage under test, the readings should be multiplied by two, each division on the scale now representing twice the value marked on the scale.

As an example, suppose it be desired to read 100 volts on the 40-volt voltmeter shown in Fig. 9. A full scale deflection requires 0.4 milliampère through the voltmeter. Using Ohm's law :-

$$R = \frac{E}{I} = \frac{100 \text{ v.}}{.0004} = \frac{1,000,000}{4} = 250,000\Omega$$

therefore the **total resistance** of the voltmeter must now be 250,000 Ω . As it is already 100,000 Ω , we must connect in series an additional resistance of 150,000 Ω .

The scale markings will now be too small by the value $\frac{100 \text{ v.}}{40 \text{ v.}}$ and it is therefore necessary either to re-mark the scale or to use a multiplying factor. Thus, if a deflection of 30 volts be obtained on the 250,000 Ω voltmeter converted as above, the true value of the voltage under test will be $30 \times \frac{100}{40} = 75$ volts, the multiplying factor being $2\frac{1}{2}$; in other words, the

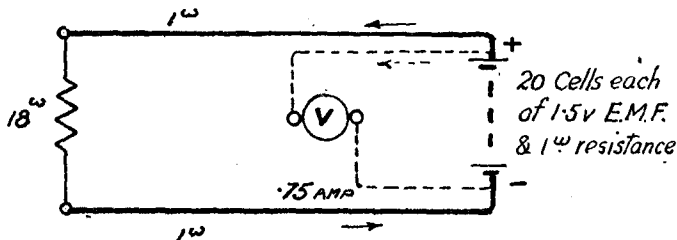

Fig. 10.

value of each volt division on the 40-volt scale has been increased two and a half times, the 1-volt mark now representing $2\frac{1}{2}$ volts and so on.

A voltmeter may be left permanently connected across a circuit without depriving that circuit of an appreciable current and without endangering the voltmeter coils through overheating, **provided** the maximum voltage of the circuit does not exceed the full scale reading or range of the instrument. **It is important to note that** a voltmeter indicates the Potential Difference between the two points of a circuit to which it is connected, and not the total E.M.F. in circuit.

As an example of this, assume that the voltmeter is connected as shown in Fig. 10, and the deflection with values assumed will be 15 volts; now the current is equal to

$$\frac{30 \text{ volts (Total E.M.F. available)}}{(20 \times 1) + 18 + 1 + 1 \text{ (Total resistance)}} = \frac{30}{40} = .75 \text{ ampère.}$$

and the external resistance is 20 Ω , therefore the P.D. by calculation is $20 \times .75 = 15V$, as would be shown by the

deflection. If the external circuit be momentarily disconnected, the voltmeter would then measure the open-circuit voltage of the battery, *i.e.*, the E.M.F., 30 volts. The difference between the two readings (15 volts) indicates the "drop in volts" in the battery itself, due to the internal resistance of the cells. This principle is made use of in practice to ascertain the value of the **internal resistance of a battery**, as detailed in Test No. 22, Loose Leaf Diagram T. 100.

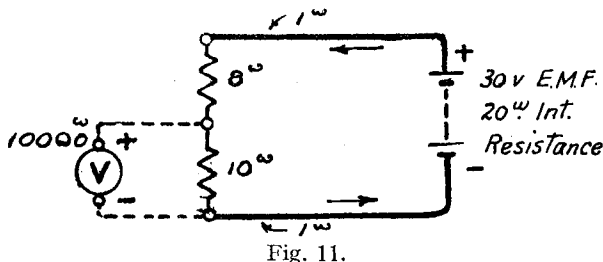

Fig. 11.

If the resistance of a part of the external circuit be known, then, by connecting a voltmeter of suitable range in parallel with the known resistance, and reading off the volts from the voltmeter scale, the value of the current in amperes flowing through the known resistance may readily be calculated.

Example.—What is the value of the current in amperes flowing through the 10Ω coil shown in Fig. 11?

Connect up the voltmeter as shown in Fig. 11, and read off the value of 7.5 volts. Then the current flowing through the

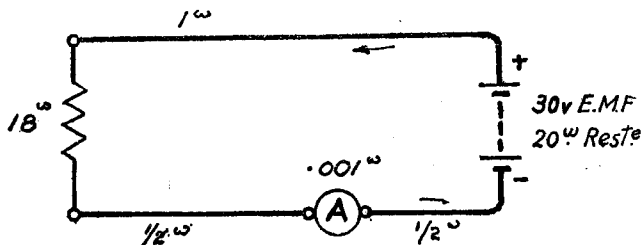

Fig. 12.

10Ω coil is equal to the 7.5 volts P.D. across the ends of the 10Ω coil divided by the resistance of the coil, or $\frac{7.5}{10} = .75$ ampère = 750 milliamperes.

Ampère meters.—An ammeter is designed to measure the value in amperes of the current in a circuit, and therefore the

instrument must be of low resistance so as to permit of it being connected directly **in series** in the circuit. Owing to its low resistance, **an ammeter must never be connected in parallel** with a main circuit, otherwise an extremely large current will pass through the instrument and damage the moving parts and coils, and probably break the pointer.

The correct method of connecting an ammeter to measure the current in a circuit is shown in Fig. 12.

The value of the current in ampères is read directly from the scale; in the above figure the current would be .75 amp.

In the case of a "**moving-coil**" type of ammeter, the instrument is of exactly the same construction as a moving-coil

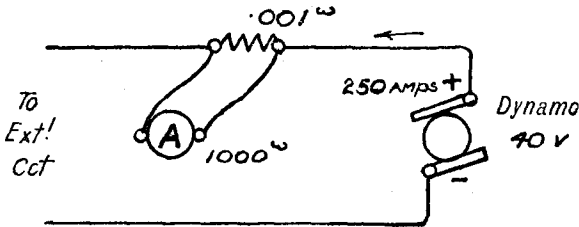

Fig. 13.

voltmeter, but its resistance is reduced to such a value that when the ammeter is inserted in a circuit, it will not appreciably reduce the value of the main current.

From the above it will readily be seen that to convert the voltmeter, shown in Fig. 9, into an ammeter, all that is necessary is to connect the 1,000Ω moving coil **in parallel** with a very low resistance shunt (the 9,000 and 90,000Ω coils not being required); the shunted instrument can then be inserted directly **in series** in a main circuit. The **shunt** associated with the moving coil should be designed to permit the passage of the maximum current obtainable in the main circuit for which the instrument is required, whilst the **moving coil** will only take an extremely small proportion of the main current. The scale of the instrument is marked in ampères, the divisions being uniformly divided, as in the moving-coil type of voltmeter.

In ammeters designed to measure current up to a few ampères only, the shunt coil is generally accommodated inside the instrument, but for large currents, *e.g.*, on telephone exchange power boards, the main shunt is located outside the instrument, two leads being provided to connect the shunt to the ammeter. The leads and shunt are of a definite resistance as compared with the resistance of the moving coil and, therefore, such a shunt, with its pair of leads, can only be used on the particular instrument with which it is associated.

The connexions of a shunted ammeter, connected in series with a dynamo, are given in Fig. 13.

In Fig. 13 it will be seen that, in effect, there is a voltmeter of $1,000\Omega$ resistance measuring the difference of potential in volts at the ends of a resistance of $\cdot 001\Omega$ ($\frac{1}{1000}$ th Ω).

If a current of $\cdot 0004$ ampère through the $1,000\Omega$ coil alone will produce a full scale deflection of 40 divisions on the instrument, then it follows from Ohm's law that the voltage applied to the terminals of the instrument necessary to give a current of $\cdot 0004$ ampère is equal to $\cdot 4$ volt, *i.e.*, $E = I \times R = \cdot 0004 \text{ ampère} \times 1,000\Omega \times \cdot 4 \text{ volt}$.

Referring again to Fig. 13, and assuming the main current to be 250 ampères, the potential difference at the ends of the ammeter shunt will be equal to $E = I \times R = 250 \text{ amps.} \times \cdot 001\Omega = \cdot 25 \text{ volt}$.

As $\cdot 4$ volt gives 40 divisions, $\cdot 25$ volt will give 25 divisions, or $\frac{\cdot 25}{\cdot 4} \times 40 = \frac{25}{40} \times 40 = 25$ divisions deflection.

As the P.D. measured across $\cdot 001\Omega$ is thus $\cdot 25$ volt it follows that the current through the shunt will be $\frac{\cdot 25}{\cdot 001} = 250$ amps.; on the same basis, the current necessary to give 40 divisions deflection will be 400 ampères. Such an instrument would be called a $0\cdot 400$ ampèremeter.

By using shunts of different values, the ammeter could be made to read either lower or higher values of current as desired, suitable switching devices being used to introduce the other shunts as required.

DETECTOR No. 2.

This instrument, shown in Fig. 14, is a combined voltmeter and ampèremeter, and is one of the most useful portable testing instruments for telephone and telegraph maintenance purposes. The instrument is constructed on the moving-coil principle.

The resistance of the coil of the Detector No. 2, wound on the movable frame, is 60Ω , but by introducing several resistance coils fitted inside the instrument, together with a small change-over switch on the top of the case, it is possible to measure voltages up to 50 and currents in milliamperes up to 500, *i.e.*, $\frac{1}{2}$ ampère, provided that the correct terminals are used and that the switch on the top of the case is moved to the proper position, according to whether volts or milliamperes are to be measured.

For full details of connexions and method of using the instrument, reference should be made to Loose Leaf Diagram T. 102, sheets 1 to 16, reproduced at the end of this pamphlet.

The following notes, relating to the Detector, will perhaps be of assistance to those who have not yet had the opportunity of studying and using the instrument to any great extent.

There is only one operating coil in the detector and that is the 60Ω moving coil; all the other coils (resistors) are merely introduced for the purpose of extending the range of the instrument to read up to the values mentioned above. The additional coils are wound non-inductively, *i.e.*, the wire is wound on a bobbin without an iron core, and two wires are wound on together side by side, the inner or starting ends being connected

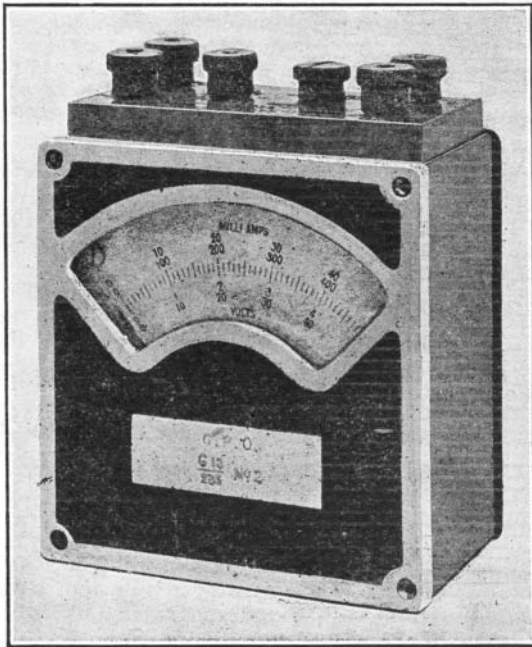

Fig. 14.

together, whilst the two other ends are brought out to terminals. By winding the coils in this fashion, there is no external magnetic effect due to a current passing through the resistors.

It is found that with the moving coil wound to 60Ω resistance, it is necessary to pass 10 milliampères through it in order to obtain a deflection of the pointer to the end of the scale, the latter being divided uniformly into 50 divisions.

Voltage Tests.—Knowing this constant of 10 milliampères it is then easy to make up the instrument so as to indicate
(SO 2094)

volts when the pointer is on the 50th division of the scale. In other words, as 10 milliampères will give a full scale deflection, the total resistance of the instrument must be increased so as to limit the current through the 60Ω moving coil to 10 milliampères. For this reason, an additional 440Ω resistor is connected in series with the 60Ω moving coil, making a total of 500Ω . (Switch on "Volts" and terminals 2 and 4 in use. See Diagram T.102, Sheet 1.)

Now, assuming a battery with an E.M.F. of 5 volts to be connected to the Detector, it will be seen that only 10 milliampères can flow through the coils :—

Example.

$$I \text{ (in amps.)} = \frac{\text{E.M.F.}}{\text{Resistance}} = \frac{5 \text{ v.}}{500\Omega} = .01 \text{ ampère}$$

$\frac{1}{100}$ th amp. or 10 mA.

Similarly, if it be desired to measure voltages up to 50, then the total resistance of the Detector must again only permit 10 mA. to flow when the battery under test has an E.M.F. of 50 volts. In this case, the total resistance of the Detector must be exactly 10 times the resistance when only measuring 5 volts, *i.e.*, $5,000\Omega$. For this purpose, an additional $4,500\Omega$ resistor is connected in series with the 440Ω resistor and the 60Ω moving coil. (Switch on "Volts" and terminals 2 and 5 in use. Diagram T.102, Sheet 1.). To make the instrument capable of measuring up to 100 volts when the pointer is on the

50 division, the total resistance must now be $R = \frac{E}{C} = \frac{110 \text{ volts}}{.01 \text{ amp.}}$

$= 10,000\Omega$, *i.e.*, an additional resistance of $5,000\Omega$ is necessary. This additional resistance can readily be obtained by using the $5,000\Omega$ of Coil, Testing No. 1, connecting the coil as shown in Test No. 5, Diagram T.102, but as the detector scale is only marked up to 50 volts, each division will now be equal to 2 volts, a deflection of 40 representing a voltage of 80, and so on. To measure up to 150 volts an external resistance of $10,000\Omega$ must be added to the voltmeter (two $5,000\Omega$ Testing Coils, No. 1, in series).

Current Tests.—In order to use the Detector No. 2 for measuring the value of a current flowing in a main circuit, it is necessary to reduce the resistance of the 60Ω coil by introducing suitable shunts. For this purpose, two shunts, shown in the Loose Leaf Diagram T.102, Sheet 1, are used, so that when measuring a current as in Tests 7 and 8, Diagram T.102, the resistance of the Detector is 1.47Ω (nearly $\frac{1}{4}\Omega$) for measuring currents over 50 and not exceeding 500 milliampères, and 12Ω for currents not exceeding 50 milliampères. The two shunts are inside the Detector and are only in circuit when the switch is turned to "M/Amps."

By using a shunt of 0.121Ω (approximately $\frac{1}{8}$ th Ω) in

parallel with terminals 2 and 3, it is possible to measure currents up to a value of 5 ampères, each division now representing 1/10th of an ampère, but for general purposes the standard shunts are adequate. (See Test No. 9, Diagram T.102.)

On later patterns of Detector No. 2, an additional connecting point is provided. (Terminal marked No. 6 on Sheet 1, Diagram T.102). By using the common, *i.e.*, negative, terminal of the instrument (No. 2 in the diagram), together with terminal 6, and with the switch turned to "Volts," it is possible to obtain contact with the 60Ω moving coil only. This arrangement converts the instrument into a voltmeter which will read low voltages up to 0.6 volt, and also permits of the measurement of low resistances, as shown in Tests Nos. 1 and 10, Diagram T.102.

Low Resistance Tests.—The principle of low resistance tests is that a test for voltage is made across a known resistance of low value connected in series with the unknown resistance. With conditions unaltered, another voltage test is then made across the unknown resistance. The "drop in volts" across each of the two resistances is proportional to their resistances, *i.e.*, if 10 divisions is obtained across the known resistance of say 2Ω and 20 divisions obtained across the unknown resistance, the latter is exactly twice the value of the known resistance. Stated in another way, the value of the unknown resistance is equal to the **known resistance** (in ohms) multiplied by the **number of divisions obtained across the unknown resistance**, this result to be obtained by the **number of divisions obtained across the known resistance**. (See Test No. 10, Diagram T.102.)

High Resistance Tests.—Detector No. 2 is now used on small test sets fitted at medium-sized exchanges, for the purpose of testing subscribers' and junction circuits. By means of a few keys, it is possible to vary the testing connexions so as to permit of tests for earth on "A" or "B" lines, short circuits, contacts, etc., being made very rapidly and accurately.

It is sometimes difficult to remember the formula for calculating the value of a high resistance tested by means of Detector No. 2 and a few cells (Test No. 13 Diagram T.102), but if the detector constant of "**10 milliampères equals 50 divisions**" deflection when using the "volts" terminals be remembered, it is a comparatively easy matter to ascertain the value of the resistance under test.

Example.—Ten cells with a total E.M.F. of 15 volts, are connected in series with the Detector (terminals 2 and 5 with Switch on "volts") and an unknown resistance. The deflection obtained is just over 8 divisions. With a little practice, the exact position of the pointer can be estimated very closely, by assuming that each small division is divided into 10 parts, and the final estimate in the above case is that the pointer is at

a position of less than half a division past the 8th, day three-tenths (0.3) of a division. The deflection is therefore 8.3 divisions. What is the value of the unknown resistance?

Knowing that 10mA. is represented by a deflection of 50 divisions, it follows that 8.3 divisions must represent much less than 10 mA. Actually it represents—

$$\frac{8.3}{50} \times 10 \text{ mA. or } \frac{83}{50} = 1.66 \text{ mA.}$$

Converting this into ampères by dividing it by 1,000, we obtain .00166 amp. as the current (I).

The voltage is 15, therefore by Ohm's law we know that $R = \frac{E}{I}$, and the total resistance of Detector, unknown resistance, and battery is equal to

$$\frac{E}{I} = \frac{15}{.00166} = \frac{1,500,000}{166} = 9,036\Omega.$$

Being relatively small, the resistance of the battery can be

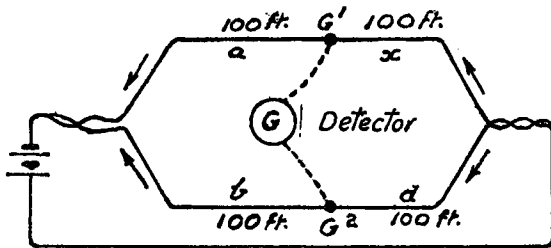

Fig. 15.

neglected, but the resistance of the voltmeter (5,000 Ω) must be deducted, leaving 4,036 Ω as the value of the unknown resistance. Although this might appear complicated, it is so useful that, once grasped, the method will invariably be used in practice. If the resistance under test be much higher, even the resistance of the voltmeter could be neglected without serious error, as, for instance, when testing insulation resistances.

(See Page 27 for Detector No. 4.)

WHEATSTONE BRIDGE.

This is an arrangement for testing the resistance of lines, cables, apparatus, etc. Full details of the connexions and method of using the "bridge" for various tests are given in detail in Technical Instruction IV. For the purpose of this pamphlet, only the principles of the Wheatstone Bridge need to be touched upon.

Suppose we have a circuit of two uniform conductors, each 200 feet long, and this circuit is looped at each end and then connected by means of a third wire to a battery of two cells, as shown in Fig. 15. A current will circulate in both wires as indicated by the arrows, and the current in each conductor of

the loop will be exactly equal, *i.e.*, half the main current will pass through each wire. If now we connect a sensitive Detector across the loop at the points G_1 and G_2 , we shall find that no deflection will be obtained so long as G_1 and G_2 respectively are half way along the line. Further, if G_1 and G_2 are moved uniformly along the two wires in the same direction, then still no deflection will be obtained. If, however, we move G_1 alone a few feet to the left or the right, a deflection on the testing instrument will be observed. The same result will be obtained if G_2 alone be moved to the left or right.

The explanation of this is that the points G_1 and G_2 when no deflection is obtained on the Detector are said to be at equal potential. Stated in another way, if we connect a short piece of wire across the circuit at these points the "balance" of the circuit is not disturbed; there is no tendency for current to flow from one side of the circuit to the other via the cross-wire. The cross-wire can be moved towards either end without any current flowing in it, providing it is connected at points equidistant from the ends of the two wires.

This principle is taken advantage of in the testing of resistance by the Wheatstone Bridge method. For instance, if we had desired in the above example to obtain another length of wire exactly equal to the portion marked x , the latter would be removed and the new wire put in its place, the other connexions remaining as in the figure.

If the new wire were too long, a deflection, say, to the right, would be obtained on the detector. If it were too short a deflection to the left would be obtained. Assuming that the wire were too long, it would be shortened bit by bit, and it would be seen that the deflection gradually drew nearer to the centre of zero mark on the detector, until, when the exact length had been obtained, the detector would indicate no deflection. The bridge is then said to be balanced, that is, the four arms, a , b , d , and x , are related to each other in a definite way:—thus, if a and b are equal lengths of the same sort of wire, and d is given a value five times as high as either a or b , then a "balance" cannot be obtained until another wire is put in the arm x equal to the value of arm d .

If a is made ten times as high as b , and d is made equal to b , then again balance will not be obtained until x is equal to a .

Let each of the three arms, a , b , d , be as follows, then what should be the value of x in order to get a "balance"?

$$a = 100\Omega$$

$$b = 100\Omega$$

$$d = 500\Omega$$

From the above, it will be seen at a glance that X must be 500Ω , but it is better to write the problem down thus:—

$$x = \frac{a}{b} \times d, \text{ or } \frac{100}{100} \times 500 = 500\Omega.$$

By making a and b in the form of three resistance coils each, of values 10Ω , 100Ω , and $1,000\Omega$, and d in the form of a rheostat, with values from 1Ω to $11,110\Omega$, as in Fig. 16, it is possible to measure high or low resistances connected in arm x by varying the resistances unplugged in arm d , arms a and b to be of the same value.

When small resistances are to be measured, say, less than 100Ω the resistance of b should be 10 to 100 times greater than a , so as to ensure greater accuracy in the measurement.

If only approximate results are required, the arms a and b may be equal in value, say 10Ω , 100Ω , or $1,000\Omega$ each, according to which of these values is nearest to the assumed resistance of the line or coil under test in arm x .

WHEATSTONE BRIDGE

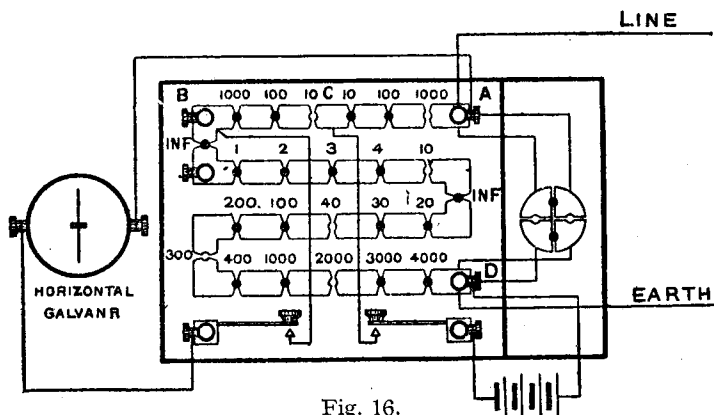

Fig. 16.

The connexions in Fig. 16 show the method of testing a line. In **testing for conductivity**, put the line to earth at the further end; **in testing for insulation**, leave it disconnected.

To test a loop, or any resistance of which both ends are accessible, join one end to A and the other to D, and use no earth connexion.

Resistance must always be left in between A and C, and C and B. The resistance in AC, divided by the resistance in CB, and multiplied by that in BD, gives the resistance under test. AC and CB are known as the "ratios," and BD as the "rheostat."

Example.—If, in the conditions shown in the diagram, a balance is obtained, then the (insulation) resistance of the line is known to be

$$\frac{1000 \times 2350}{10} = 235,000\Omega.$$

THE MEGGER.

This set is a combination of a double moving coil instrument, having a scale calibrated to indicate directly in megohm and a hand dynamo. A diagram of connexions is given in Fig. 17.

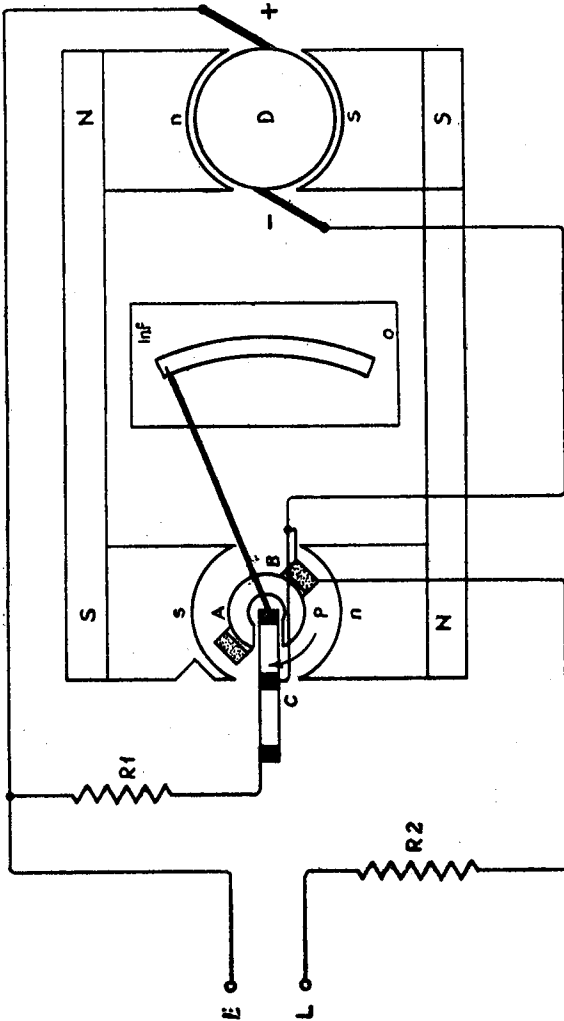

Fig. 17.

The moving portion of the instrument consists of two coils, a pressure coil and a current coil, fixed upon the same axle at nearly right angles to each other, with a stout pivot at each end working in jewelled cups. The pressure coil circuit has a resistance of approximately $100,000\Omega$, and is connected direct to the terminals of the dynamo. In series with the current coil is a resistance of $200,000\Omega$; this circuit is connected at one end to the positive pole of the dynamo, and at the other, to the "line" terminal. The "earth" terminal is connected to the positive pole of the dynamo.

The **dynamo** is a direct current generator, with a special commutating device. The armature runs on roller bearings, and between it and the handle a friction clutch is interposed in the driving gear. The clutch is adjusted to maintain the speed of the dynamo constant when the handle is turned at a speed of 120 or more revolutions per minute.

One end of a combination of powerful bar magnets provides the field for the dynamo, and the other end the field for the moving coil system.

The force acting upon the voltage coil tending to turn it is practically proportional to the E.M.F. in the circuit, whilst the force tending to deflect the current coil is proportional to the current in that coil. If the resistance in the current coil circuit were infinite, the system would be deflected by the force acting upon the pressure coil alone, and the needle would then point to "infinity." When the voltage applied to the pressure coil is constant, the deflection of the needle from zero varies in accordance with current in the current coil, and is directly proportional to the resistance in its circuit. If, however, the voltage applied to the pressure coil varies, and if the resistances in the circuits are constant, then the currents in both coils and, consequently, the deflecting forces acting upon them, will vary with the voltage, but the ratio between the forces will remain as before and equilibrium will be maintained. The position of equilibrium taken up by the moving system has, therefore, a constant relation to the ratio $\frac{E}{I}$, which is, of

course, a measurement of R . (The resistance of $200,000\Omega$ in the current coil circuit is allowed for in the calibration.)

The "Megger," as described above, is capable of measuring resistances of several million ohms (Megohms), and, consequently, is not suitable for measuring low resistances. A later type of instrument known as the "Bridge Megger," combines the functions of the Megger, and the Wheatstone Bridge.

A change-over switch is fitted on the set, which alters the connexions from Megger working to Wheatstone Bridge working. A different set of line terminals is used, together with some form of adjustable rheostat (Rheostat "F").

The rheostat takes the place of the arm d in the Wheatstone Bridge, and is connected to terminals marked "R," whilst the line or piece of apparatus under test is connected to terminals marked "X."

When the set is used for Wheatstone Bridge tests, the adjustable rheostat is gradually adjusted until no deflection is obtained when the megger handle is turned, then the value of the resistance under test is equal to the value unplugged in the rheostat.

An additional switch, called a "ratio switch," is used to vary the resistance in the arms a and b , as in the case of an ordinary Wheatstone Bridge, so that lower or higher resistances may be measured, as in the bridge method previously described. A special feature of the "bridge megger" is that it is very portable. The readings for insulation resistances are directly read off the scale without the necessity for making calculations, and by the use of the ratio switch, it is only necessary to multiply or divide the value unplugged in the rheostat by 10 or 100, as the case may be. It may be used in the vicinity of dynamos, etc., without the readings being affected.

DETECTOR No. 4.

This instrument, shown on Figures 19 and 20, may be regarded as an improved Detector No. 2, being lighter, more compact, and designed so that tests may be made with a greater degree of accuracy. A full scale deflection is given with 10 milliampères of current in the "moving coil."

Terminals 1, 2 and 3, with the associated rotary switch, fulfil the identical functions of Terminals 1, 2, 3, 4, and 5, with switch of the Detector No. 2.

Terminal 4 corresponds to Terminal 6 in the Detector No. 2, but the resistance of the moving-coil circuit, using terminals 2 and 4 of the Detector No. 4 is only 10Ω , as compared with 60Ω when terminals 2 and 6 of the Detector No. 2 are used. The advantage of the lower resistance moving-coil circuit is that a greater deflection is obtained when measuring potential differences across resistances of very low value. This will be apparent by comparing Test 1, T.116, with Test 1, T.102.

In order that the normal voltage and current ranges of the instrument may be increased, resistors (which may be attached to Terminal 2 or 3) and shunts (which may be connected across Terminals 2 or 3) are provided. Figure 18 gives a general view of the Detector and shows typical accessory resistances and shunts. A small spike which is included in the instrument is also shown detached. The spike is provided to facilitate testing when it is convenient to use this means of making a connexion and is shown fitted in Figure 20.

The internal connexions of a typical instrument are shown in Figure 21.

The principal ranges of the instrument are given in the following table :—

Range.	Terminals.	Switch at	Value per division.	Resistance in ohms.	External shunts and resistance in use.
Current :					
0-50 mA ..	2 & 1	50 mA	1.0 mA	12.00	None
0-500 mA ..	2 & 1	500 mA	10.0 mA	1.47	None
0-5 A ..	2 & 4	50 V	100.0 mA	0.02	5 Amp. shunt
0-25 A ..	2 & 4	50 V	500.0 mA	0.004	25 Amp. shunt
Volts :					
0-0.1 V ..	2 & 4	50 V	.002v	10	None
0-5 V ..	2 & 3	5 V	.100v	500	None
0-50 V ..	2 & 3	50 V	1.000v	5,000	None
0-100 V ..	2 & 4	50 V	2.000v	10,010	10,000 Ω resistance
0-150 V ..	2 & 3	50 V	3.000v	15,000	10,000 Ω resistance
0-250 V ..	2 & 3	50 V	5.000v	25,000	Two 10,000 Ω resistances in series

For other ranges and full details of the connexions under different conditions, also the method of using, reference should be made to loose-leaf diagrams T.116-131 (16 sheets), copies of which are reproduced at the end of this pamphlet.

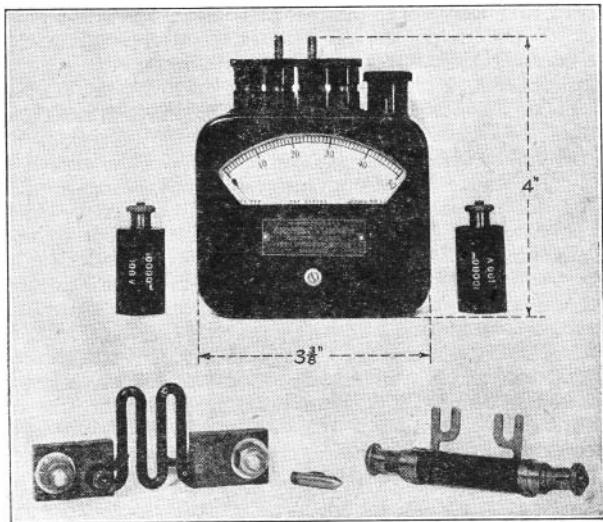

Fig. 1 General view of Detector No. 4 and parts.

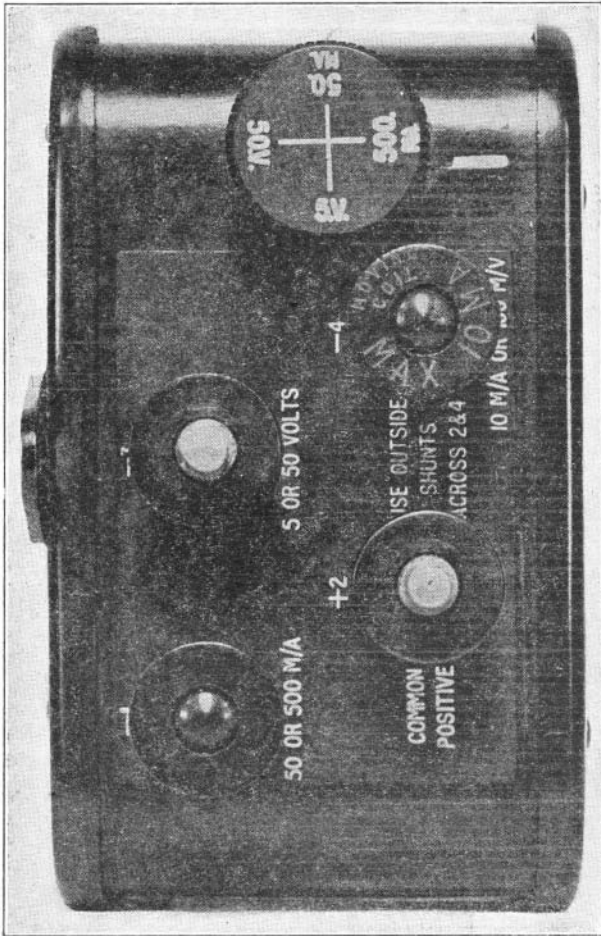

Fig. 19. Plan of Top, showing Terminals.

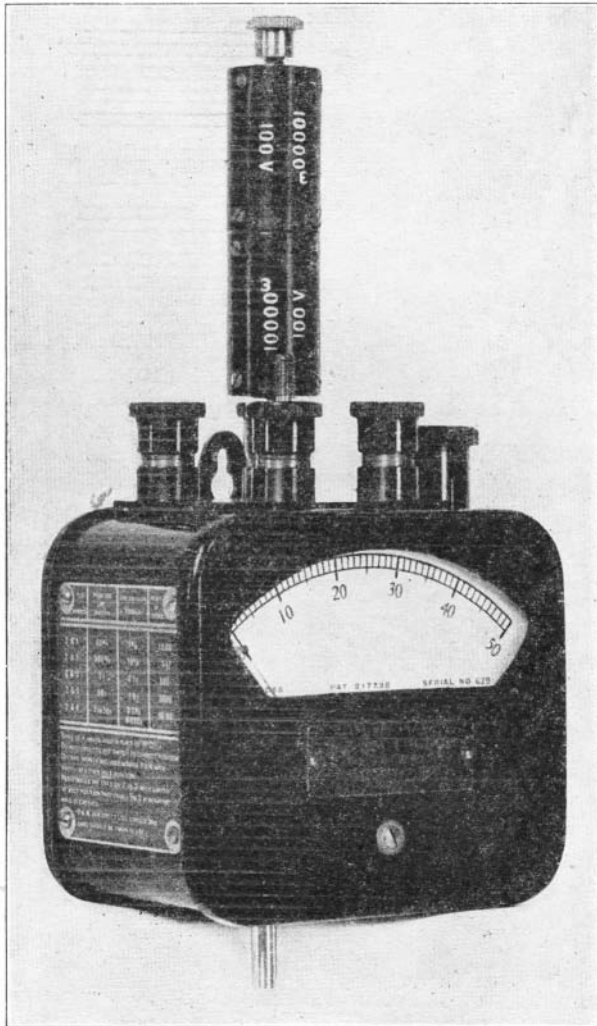

Fig. 20. Detector with both Multipliers on Terminal 3 and spikes on base.

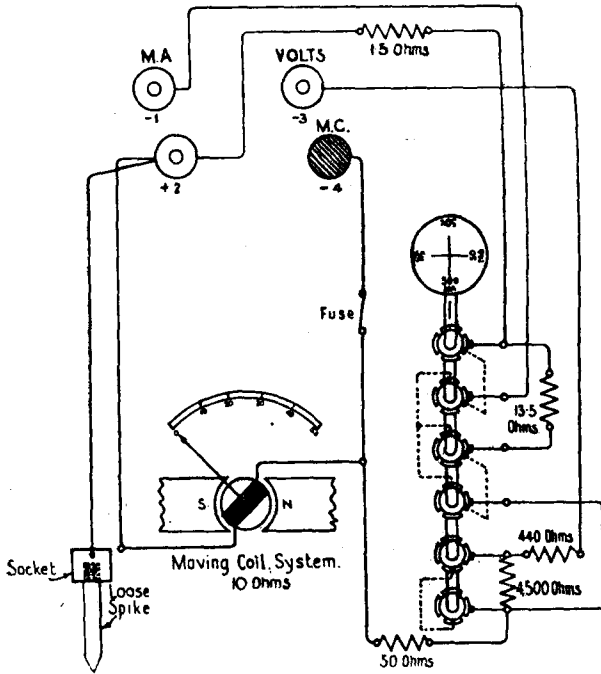
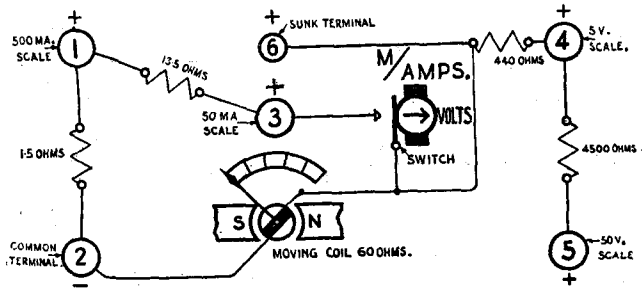
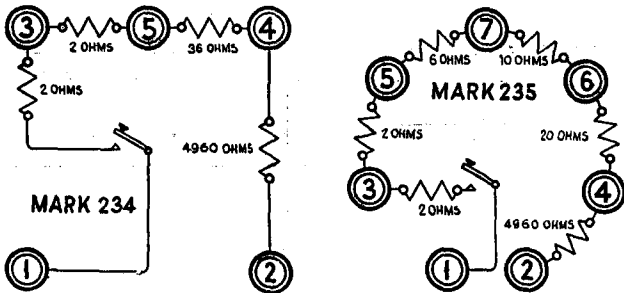

Fig. 21. Internal Connexions of Detector.

DETECTOR, No. 2, & COIL, TESTING, No. 1.



The Figure shows the Internal Connexions of the Detector, No. 2.



The Figures show the Internal Connexions of two types of Coils, Testing, No. 1.

PROCEDURE IN MAKING TESTS.

GENERAL NOTES.

In no case should the Detector be permitted to remain in circuit if the full scale deflection is exceeded.

In doubtful cases always test first for a high voltage or heavy current, and thus safeguard the moving coil from being fused.

The Pointer of the Detector can be adjusted to zero by means of the screw at the base of the instrument.

In the explanatory figures which follow the Terminals of the Detector are shown by single circles and the Terminals of the Testing Coil by double circles.

DETECTOR, No. 2, & COIL, TESTING, No. 1.

VOLTAGE TESTS.

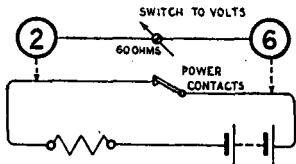

1. 0 to 0.6 Volt.—Each small division on Detector Scale represents .012 volt, i.e., 12 millivolts. The reading on the 50 volt scale multiplied by 12 equals millivolts.

Test is suitable for checking conductivity of joints on Power Cables, Switches, &c. To avoid damage to Moving Coil, Test (3) should always precede Test (1) and the latter should be made when the voltage in Test (3) is less than .6 volt, i.e., 6 small divisions.

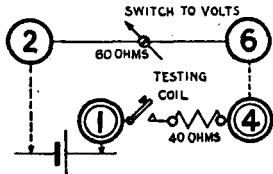

2. 0 to 1 Volt.—Each small division on Detector Scale represents .02 volt, i.e., 20 millivolts.

The reading on the 50 volt scale multiplied by 20 equals millivolts.

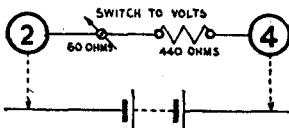

3. 0 to 5 Volts.—Each small division on Detector Scale represents .1 volt.

The voltage across the terminals of the Detector is indicated by the reading on the 5 volt scale.

To test Relay or Night Bell Contacts for resistance, connect Terminals (2) and (4) across same. No resistance is indicated by no deflection when current is flowing through contacts.

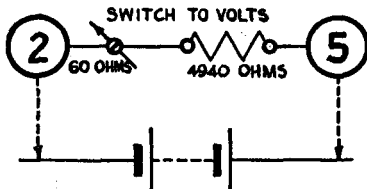

4. 0 to 50 Volts.—Each small division on Detector Scale represents 1 volt.

The voltage across the Terminals of the Detector is indicated by the reading on the 50 volt scale.

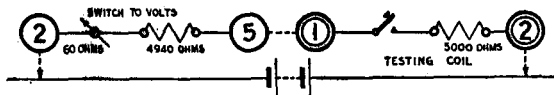

5. 0 to 100 Volts.—Each small division on the Detector Scale represents 2 volts. The reading on the 50 volt scale multiplied by 2 gives the voltage across Detector and Testing Coil.

DETECTOR, No. 2, & COIL, TESTING, No. 1.

VOLTAGE TESTS—continued.

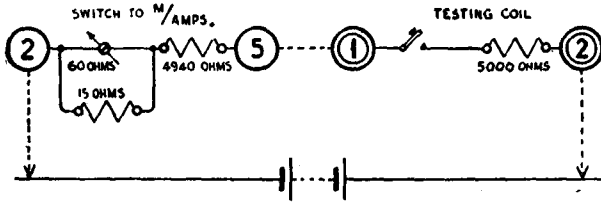

6. 0 to 250 Volts.—Each small division on Detector Scale represents 10 volts. The reading on the 50 volt scale multiplied by 10 gives the voltage across the Detector and Testing Coil. In making this test current must be left on continuously. If reading exceeds 25 small divisions, Detector should be disconnected at once.

CURRENT TESTS.

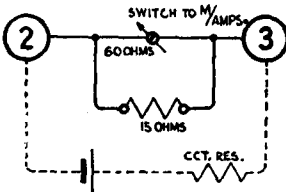

7. 0 to 50 Milliampères.—Each small division on Detector Scale represents 1 milliampère. The current flowing through the Detector is indicated by the reading on the 50 milliampère scale. The resistance of the Detector is 12Ω .

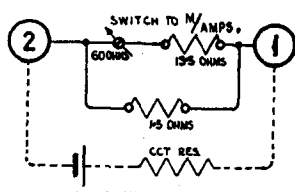

8. 0 to 500 Milliampères.—Each small division on the Detector Scale represents 10 milliampères. The current flowing through the Detector is indicated by the reading on the 500 milliampère scale. The resistance of the Detector is 1.47Ω .

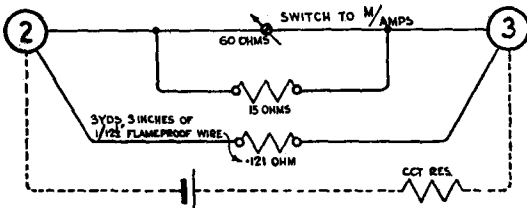

9. 0 to 5 Amperes.—Each small division on the Detector Scale represents 0.1 ampère. The reading on the 5 volt scale may be regarded as representing amperes. The resistance of the Detector is 0.12Ω .

DETECTOR, No. 2, & COIL, TESTING, No. 1.

RESISTANCE TESTS.

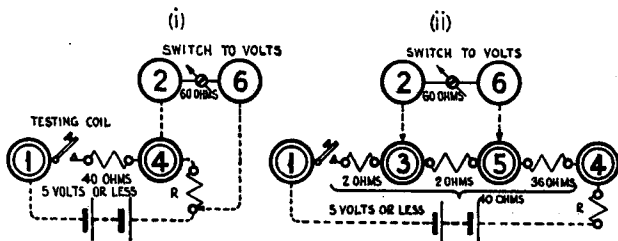

10. 0 to 5Ω.—Connect up as in (i). Note reading on 50 volt scale = V_1 . Connect up again as in (ii). Note direct reading on 50 volt scale = V_2 .

$$\text{Unknown resistance } R = \frac{2 V_1}{V_2}$$

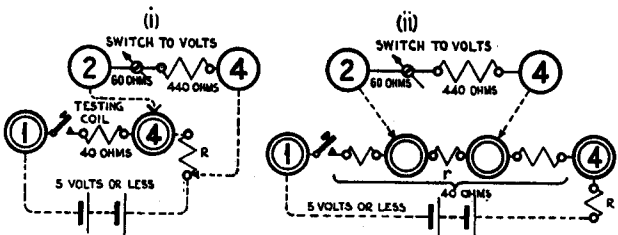

11. 0 to 500Ω.—Connect up as in (i). Note direct reading on 50 volt scale = V_1 . Connect up again as in (ii), selecting terminals on Testing Coil so that resistance r is as near as possible to the unknown resistance R . Note direct reading on 50 volt scale = V_2 .

$$\text{Unknown resistance } R = \frac{r V_1}{V_2}$$

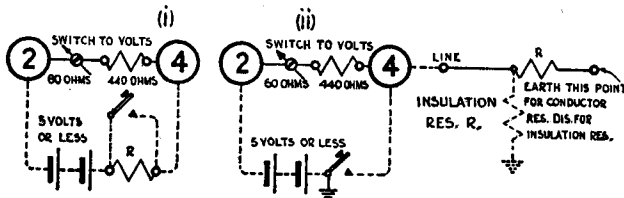

12. 0 to 24,500Ω.—Connect up as in (i) or (ii). Short-circuit R and note direct reading on 50 volt scale = V_1 . Remove short-circuit and again note direct reading on 50 volt scale = V_2 .

$$\text{Unknown resistance } R = \frac{500 (V_1 - V_2)}{V}$$

The value of R can be ascertained from the Table on Sheet 10 when V_2 is from 18 to 25 divisions or 36 to 50 divisions.

Test (ii) is more suitable for measuring low resistances.

DETECTOR, No. 2, & COIL, TESTING, No. 1.

RESISTANCE TESTS—continued.

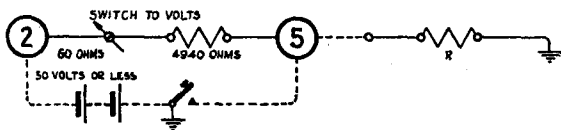

13. 0 to 245,000 Ω .—Short circuit R and note direct reading on 50 volt scale = V_1
Remove short circuit and again note direct reading on 50 volt scale = V_2 .

$$\text{Unknown resistance } R = \frac{5,000 (V_1 - V_2)}{V_2}.$$

The value of R can be ascertained from the Table on Sheet 10 when V_1 is from 18 to 25 divisions or 36 to 50 divisions.

LINE TESTS.

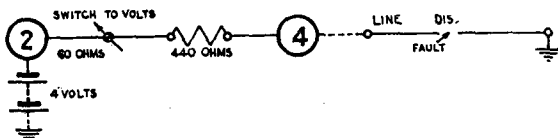

14. *Disconnection*.—Have line earthed at distant end. No deflection on Detector indicates line is disconnected.

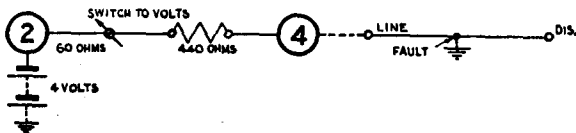

15. *Earth*.—Have line disconnected at distant end. A deflection on Detector indicates line is to earth.

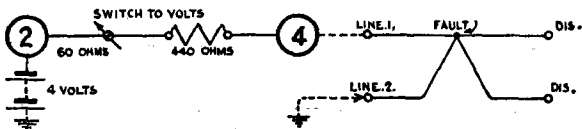

16. *Contact*.—(Exchange testing practice). Have lines disconnected at distant end. Disconnect earth from Line 2 and re-connect. A deflection or an alteration to the deflection on Detector following each connexion of "earth" to Line 2 indicates a contact.

DETECTOR, No. 2, & COIL, TESTING, No. 1.

LINE TESTS—continued.

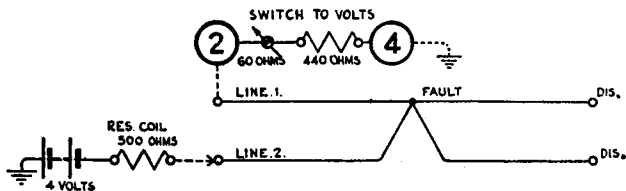

17. *Contact.*—Have lines disconnected at distant end. Disconnect battery and reconnect. A deflection on Detector following each application of the battery indicates a contact.

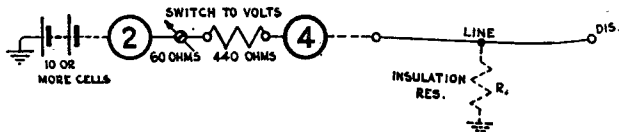

18. *Insulation Resistance.*—Have line disconnected at distant end. Deflection on 50 milliampere scale divided by 5 gives current C in milliamperes.

$$\text{Insulation resistance } R = \frac{\text{Voltage of cells } V \times 1,000}{\text{Current } C \text{ (in milliamps)}} = 500.$$

Test 12 or 13 may be taken as an alternative.

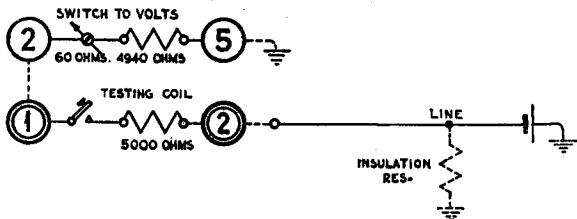

19. *Approximate Voltage at end of Line.*—The reading on the 50 volt scale multiplied by 2 gives the approximate voltage. This test is suitable for testing voltages on "permanent current" circuits when line resistance not unduly high and leakage normal.

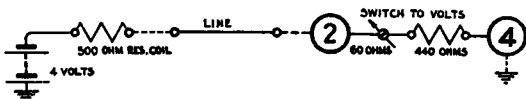

20. *To send or receive a current.*—Connect power to line through a resistance as shown in order that Loading Coils, etc., may not be damaged by a heavy current.

DETECTOR, No. 2, & COIL, TESTING, No. 1.

PRIMARY BATTERY TESTS.

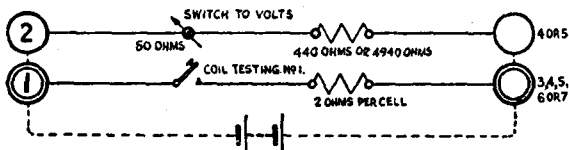

21. *Battery Testing.*—Connect up as in figure using Terminals (2) and (4) if voltage less than 5, and (2) and (5) if voltage greater than 5 but less than 50.

Note voltage = V_1 .

Depress Testing Coil Key and note voltage immediately = V_2 .

Keep Key depressed for 1 minute, then release it and note voltage immediately = V_3 .

If the battery is in a satisfactory condition :—

V_2 will be not less than 1 volt per cell.

V_2 will be not less than one half V_1 for No. 0 and No. 1 Leclanché Cells, and Dry Cells, NOT less than one third V_1 for No. 2A Leclanché Cells. If these conditions are not met test the separate cells, as described in test 22.

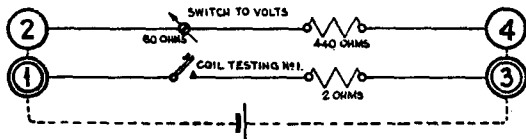

22. *Separate Cell Testing.*—Connect up as in figure.

Note voltage = V_1 .

Depress Testing Coil Key and note voltage immediately = V_2 .

Keep Key depressed for one minute, then release it and note voltage immediately = V_3 .

- (1) If, in the case of Leclanché Cells, V_3 be less than 1 volt, clean the cell and change the porous pot or sack element. In the case of Dry Cells withdraw the cell from service.
- (2) For No. 0 and No. 1 Leclanché Cells, and Dry Cells, if V_3 be above 1 volt, and V_2 be less than half V_1 , clean Leclanché Cells and refill with fresh Chloride of Ammonium solution.
Withdraw Dry Cells from service.
- (3) For No. 2A Leclanché Cells, if V_3 be above 1 volt, and V_2 be less than one third V_1 , clean the cell and refill with fresh solution of Chloride of Manganese or Chloride of Ammonium.

Leclanché Cells must be re-tested after treatment.

The internal resistance of a battery or cell may be calculated from the readings obtained under tests 21 or 22 by using the following formula :—

$$\text{Internal Resistance } r = \frac{S (V_1 - V_2)}{V_2}$$

Where S = the Testing Coil Resistance used.

DETECTOR, No. 2, & COIL, TESTING, No. 1.

PRIMARY BATTERY TESTS—continued.

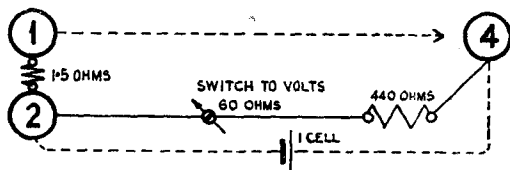

23. Cell Test for use in exceptional cases when Testing Coil not available.—The principle of Test 22 can be applied by connecting up the Detector as above. To obtain V_2 reading connect Terminal (1) to Terminal (4) and disconnect after 45 seconds for V_3 reading.

The test must not be applied to more than a single cell.

MISCELLANEOUS TESTS.

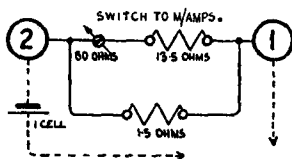

24. Point to Point Testing.—Use Terminals (2) and (1) and a single cell.

Use Test 25 for tapping out on loaded cables.

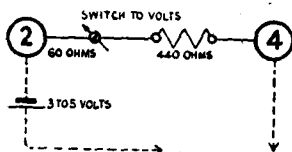

25. Tapping out on Loaded Cables.—Terminals (2) and (4) of the Detector are used in order that a heavy current may not flow to line and damage the Loading Coils.

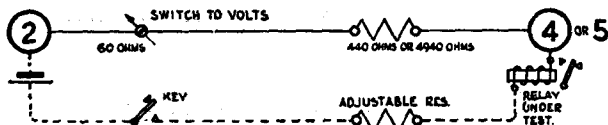

26. Operating current when less than 10 milliamperes required. See also Test 39. Connect up as in figure using suitable voltage. Each small division on Detector Scale represents .2 milliamperes. The reading on the 50 milliamperes scale divided by 5 gives current in milliamperes.

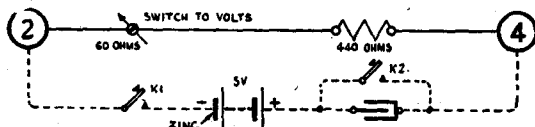

27. To prove a Condenser.—Depress Key K1. If Condenser in working order momentary deflection on Detector will be to right; if disconnected, no deflection; if short-circuited, permanent deflection. Release Key K1 and depress Key K2 to discharge condenser before repeating test.

DETECTOR, No. 2, & COIL, TESTING, No. 1.

MISCELLANEOUS TESTS—continued.

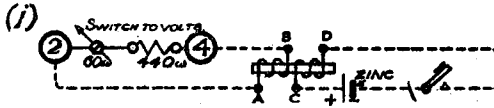

28. Test to determine correct method of joining up Relays, Bridging Coils, etc., that are double-wound, in order to obtain maximum magnetic effect or impedance.—Arrange the connexions so that momentary deflection on Detector is to left when key depressed and to right when key released. When this is the case:—

- Regard Terminal of Coil connected to Terminal (2) of Detector as A.
- " " " " " " (4) " " as B.
- " " " " " " positive pole of Battery as C.
- " " " " " " negative " " " as D.

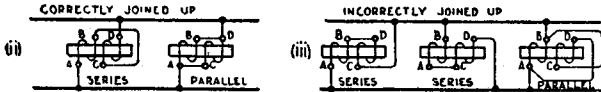

Then if the apparatus under test is joined across a telephone loop in accordance with either arrangement shown in figure (ii) it will offer considerable impedance. If arranged as shown in figure (iii) the ringing and speaking efficiency will be reduced considerably.

This test is also suitable for verifying the direction of the individual windings of a Repeating Coil or Transformer. Figures (iv), (v) and (vi) show the correct methods of joining up such apparatus under different conditions.

Repeating Coil used as a Transformer on a looped circuit.

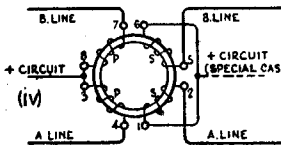

When it is required to take a + circuit from the secondary coil, a Coil Repeating 4006A or a Transformer No. 4 must be used to obtain the necessary balance.

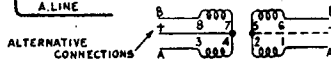

Repeating Coil used as a Transformer on an earthed circuit.

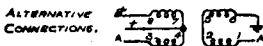
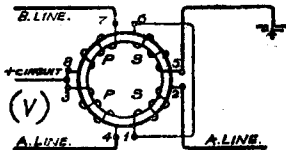

Repeating Coil used as a Bridging Coil.

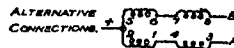
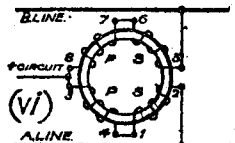

DETECTOR, No. 2, & COIL, TESTING, No. 1.

MISCELLANEOUS TESTS—continued.

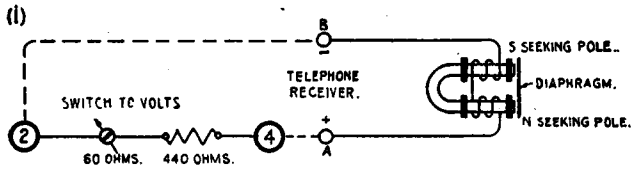

29. To join up a telephone receiver so that exchange current augments magnetic field of its polepieces. Arrange connexions as in (i) so that momentary deflection on detector is to left when diaphragm removed, and to right when diaphragm replaced. When this is the case :—

Regard terminal of receiver connected to Terminal 4 of detector as A.
 " " " " " " " " 2 " " " B.

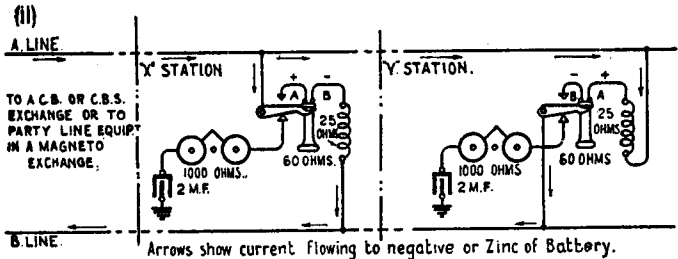

The receiver should then be joined up so that the exchange current flows through its coils from Terminal A to Terminal B as shown in (ii), i.e., Terminal A should be connected to the A line and Terminal B to the B line. The receiving efficiency of a receiver is considerably reduced when it is joined up incorrectly.

Terminals A and B are marked + and - respectively in modern receivers.

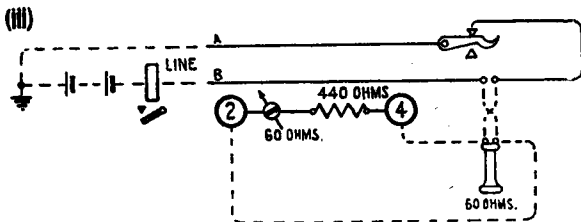

To test receiver in position.—With detector connected as in (iii) obtain reading. Press down switch hook. If receiver is joined up correctly, kick on the detector will be to left when the diaphragm is removed, and to right when diaphragm is replaced. If opposite deflections are observed, reverse receiver leads and repeat test.

DETECTOR, No. 2, & COIL, TESTING, No. 1.

MISCELLANEOUS TESTS—continued.

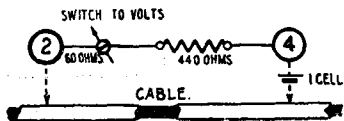

30. To demonstrate existence of induced alternating current in cable sheath.—With connexions shown, a current of about 50 periods will be indicated by the pointer vibrating.

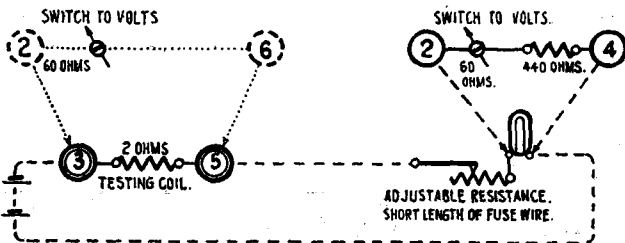

31. Current taken by a switchboard lamp rated at 5 volts or less.—Adjust E.M.F. and resistance so that reading on Detector agrees with rated voltage of lamp. When this is so, disconnect Detector and using terminals 2 and 6, connect it across 2Ω resistance in Testing Coil.

Note deflection in small DIVISIONS = D.

Current flowing through lamp in mAs = 6D.

$$\text{Resistance of lamp when glowing} = \frac{\text{Rated voltage of lamp} \times 1,000}{6D}.$$

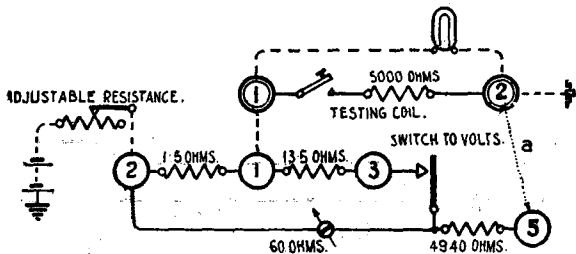

32. Current taken by a switchboard lamp rated from 5 to 50 volts.—With detector switch to volts, adjust E.M.F. and resistance so that reading on detector agrees with rated voltage of lamp. When this is so disconnect lead "a," turn Detector switch to mAs and depress key of Testing Coil.

Note current shown on the 0-500 mA. scale = C.

Current I in mAs flowing through lamp = $C - \frac{V}{5}$ where V = Rated voltage of lamp.

$$\text{Resistance of lamp when glowing} = \frac{\text{Rated voltage of lamp} \times 1,000}{=I}.$$

DETECTOR, No. 2, & COIL, TESTING, No. 1.

MISCELLANEOUS TESTS—continued.

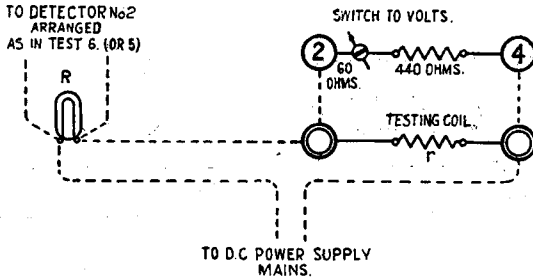

33. To ascertain current flowing through and resistance of a lamp when glowing and power supply is direct current. See also Test 34.—Using Test 3 adjust resistance “ r ” to give a convenient deflection.

Note deflection in volts = V .

The value of r to give a deflection of approximately 3 volts can be calculated. Multiply the “rated voltage” of the lamp by 3 and divide the result by the “rated wattage” of the lamp.

$$\text{Current, } C, \text{ flowing through lamp, in mAs.} = \frac{1,000 \text{ V.}}{r}$$

Using Test 6 (or 5 if suitable), ascertain voltage across lamp = E .

$$\text{Resistance } R \text{ of lamp when glowing} = \frac{1000 \text{ E.}}{C}$$

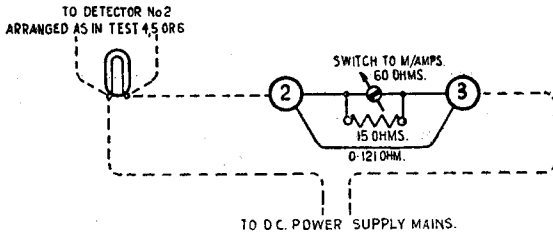

34. In the case of lamps of 75Ω or less resistance or which carry a current of more than 2.5 amps., apply this Test instead of Test 33.

Ascertain current flowing in ampères by Test 9 = C .

Ascertain voltage across lamp by Test No. 4, 5 or 6 = E .

$$\text{Resistance of lamp when glowing} = \frac{E}{C}$$

To calculate the resistance of a lamp glowing at its rated voltage:—Multiply “rated voltage of lamp” by “rated voltage of lamp” and divide by “rated wattage of lamp.”

To calculate the current carried by a lamp at its rated voltage:—Divide “rated wattage of lamp” by “rated voltage of lamp.”

DETECTOR, No. 2, & COIL, TESTING, No. 1.

MISCELLANEOUS TESTS—continued.

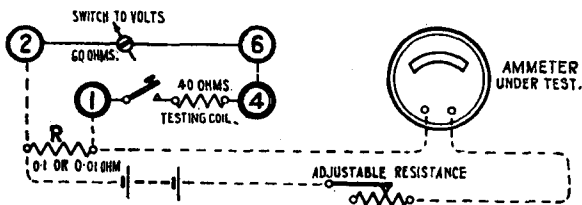

35. To verify accuracy of, or calibrate, an ammeter.

0-10 *Ampères*.—With connexions as shown, the resistance R being 0.1Ω, the ammeter should record 0.2 amp. of current for each division the detector needle is deflected.

0-100 *Ampères*.—With connexions as shown, the resistance R being 0.01Ω, the ammeter should record 2 amps. of current for each division the detector needle is deflected.

The 0.1 or 0.01Ω resistance can be made from "Wire, Flameproof, 1/12½," 2 six-yard lengths being joined in parallel for 0.1Ω resistance, and 20 six-yard lengths for the 0.01Ω resistance. The wires, when paralleled, should be tested for resistance by making a Wheatstone Bridge test, and shortened if necessary.

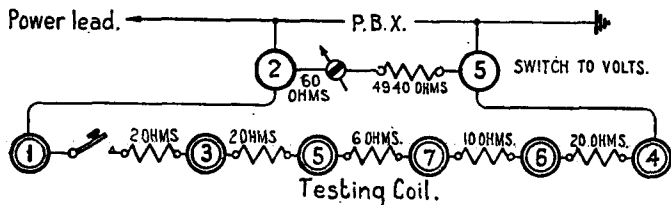

36. To ascertain resistance of P.B.X. Power lead.

Take detector reading *without* key of coil depressed. Call this V_1 .

" " " *with* " " " " " " V_2 .

Release the key and if, owing to some change in load on power lead, the detector does not return to the previous reading for V_1 , the tests should be repeated until consistent results are obtained.

$$\text{Power lead resistance} = \frac{Er V_1 - V_2}{V_1 V_2}$$

when E = P.D. of Main Exchange Bus-Bars.
 r = Resistance used on Testing Coil No. 1.
 V_1 and V_2 = Readings obtained as above.

Refer to Loose-Leaf Diagrams T.110 to T.114 for further information regarding the practical application of this test.

DETECTOR, No. 2, & COIL, TESTING, No. 1.

MISCELLANEOUS TESTS—continued.

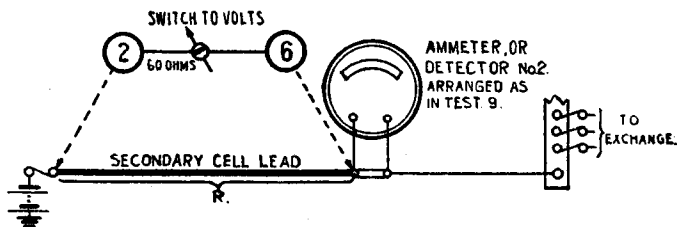

37. To ascertain the resistance of an exchange power lead.—Note the current flowing to the exchange in amperes as shown on the Ammeter = C.
At the same time note the reading on Detector, in small divisions = D.

$$\text{Resistance of lead } R = \frac{12D}{1,000C}$$

The detector leads should be of very low resistance.

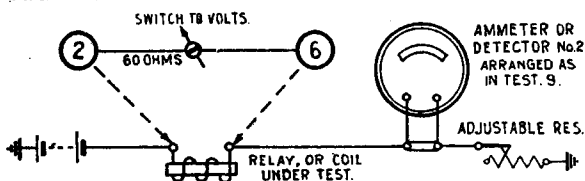

38. To ascertain resistance of a relay, or coil.—If resistance is over 1Ω , use Test No. 10, 11, 12 or 13, but if less than 1Ω , connect up as in figure.
Adjust E.M.F. and resistance so that current of .5 to 5 amps. (according to current carrying capacity of coil under test) is indicated on Ammeter.
Note reading on Ammeter, in amps. = C.
At the same time note the reading on Detector in small divisions = D.

$$\text{Resistance } R = \frac{12D}{1,000C}$$

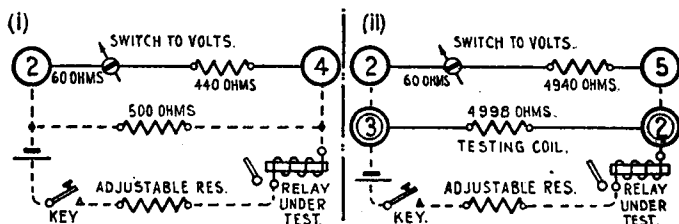

39. Operating current when less than 20 mA are required.—Connect up as in (i) or (ii), using suitable voltage. The reading on the 50 mA. scale multiplied by 2 and divided by 5 gives current flowing through relay in mA.

If less than 10 mA are required, Test 26 will give greater accuracy.

DETECTOR No. 2, & COIL, TESTING, No. 1.

MISCELLANEOUS TESTS—*continued.*

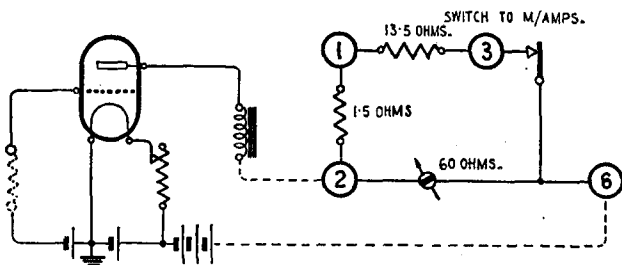

40. *To observe current flowing in plate circuit of a thermionic valve.*

0–500 mAs. Connect Detector in circuit using terminals 2 and 1, switch to M/AMPS and read direct.

0–50 mAs. Connect Detector in circuit using terminals 2 and 3, switch to M/AMPS and read direct.

0–10 mAs. Connect Detector in circuit using terminals 2 and 6, as shown in figure. If deflection is less than 10 small divisions, turn switch to VOLTS. Each small division on Detector scale then represents $\frac{1}{3}$ th of an mA.

DETECTOR, No. 4, & COIL, TESTING, No. 1.

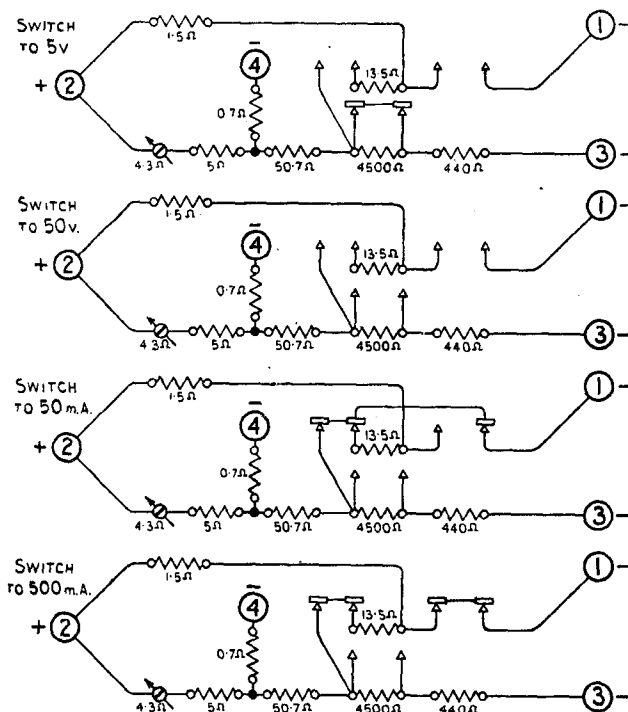

The above figures show the Internal Connexions of the Detector No. 4, Mark 234, 235 or 236 with the Switch in different positions.

The Internal Connexions of the Testing Coil No. 1 appear on Sheet (16) T.131.

PROCEDURE IN MAKING TESTS.

GENERAL NOTES.

In no case should the Detector be permitted to remain in circuit if the full scale deflection is exceeded.

In doubtful cases always test first for a high voltage or heavy current, and thus safeguard the moving coil from being fused.

The Pointer of the Detector can be adjusted to zero by means of the screw provided.

In the explanatory figures which follow, the Terminals of the Detector are shown by single circles, and the Terminals of the Testing Coil by double circles.

DETECTOR, No. 4, & COIL, TESTING, No. 1.

VOLTAGE TESTS.

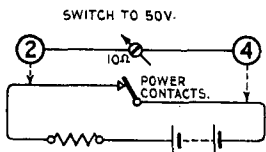

1. 0 to 0.1 Volt.—Each small division on Detector Scale represents .002 volt, i.e., 2 millivolts. A full scale deflection also represents 10 mA. of current.

Test is suitable for checking conductivity of joints on Power Cables, Switches, etc. To avoid damage to Moving Coil, Test (3) should always precede Test (1), and the latter should only be made when the voltage in Test (3) is less than 0.1 volt.

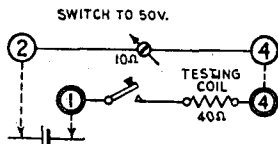

2. 0 to 0.5 Volt.—Each small division on Detector Scale represents .01 volt, i.e., 10 millivolts.

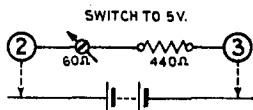

3. 0 to 5 Volts.—Each small division on Detector Scale represents 0.1 volt (100 millivolts).

The voltage across the terminals of the Detector is indicated by the scale reading divided by 10.

To test Relay or Night Bell Contacts for resistance, connect Terminals (2) and (3) across same. No resistance is indicated by no deflection when current is flowing through contacts.

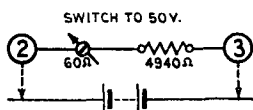

4. 0 to 50 Volts.—Each small division on Detector Scale represents 1 volt.

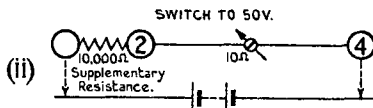
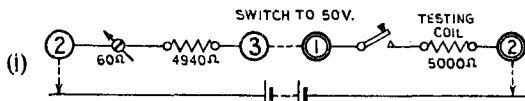

5. 0 to 100 Volts.—Each small division on the Detector Scale represents 2 volts.

The scale reading multiplied by 2 gives the voltage across Detector and Testing Coil in (I) or across the Detector and Supplementary Resistance in (II).

DETECTOR, No. 4, & COIL, TESTING, No. 1.

VOLTAGE TESTS—continued.

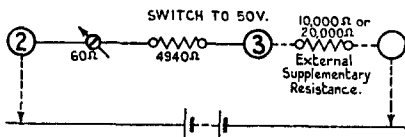

6. 0 to 150 Volts or 0 to 250 Volts.—Each small division on Detector Scale represents volts, when External Supplementary Resistance is $10,000\Omega$ and 5 volts if $200,000\Omega$.

CURRENT TESTS.

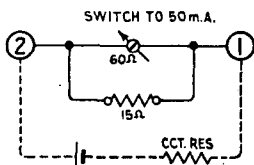

7. 0 to 10 milliamperes.—Use Test 1 preceded by the following test.

0 to 50 milliamperes.—Each small division on Detector Scale represents 1 mA.

The resistance of the Detector is 12Ω .

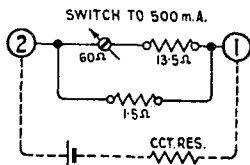

8. 0 to 500 milliamperes.—Each small division on Detector Scale represents 10 mA. The resistance of the Detector is 1.47Ω .

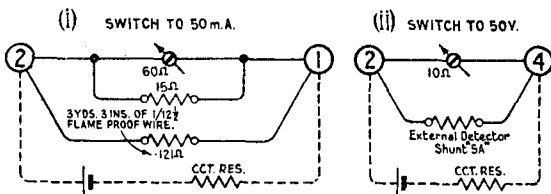

9. 0 to 5 Amperes —Each small division on the Detector Scale represents .1 Ampère. The resistance of the Detector is $.12\Omega$ in (I) and $.02\Omega$ in (II).

0 to 25 Amperes.—Connect as in (II) but use "25A" Shunt.

The resistance of the Detector is $.004\Omega$.

DETECTOR, No. 4, & COIL, TESTING, No. 1.

RESISTANCE TESTS.

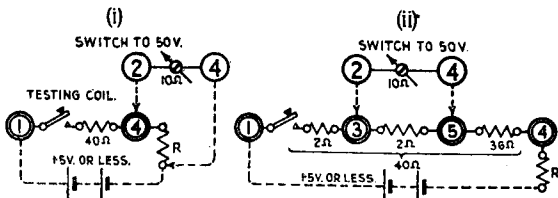

10. 0 to 4Ω .—Connect up as in (I). Note reading in divisions = V_1 .
 Connect up again as in (II). Note reading in divisions = V_2
 Unknown resistance $R = \frac{2V_1}{V_2}$.

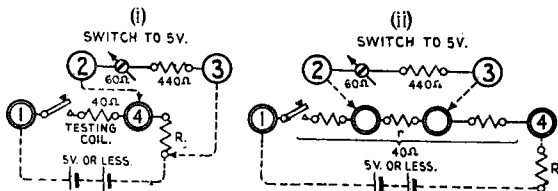

11. 0 to 500Ω .—Connect up as in (I). Note reading in divisions = V_1 .
 Connect up again as in (II) selecting terminals on Testing Coil so that resistance ris as near as possible to the unknown resistance R .
 Note reading in divisions = V_2 .
 Unknown resistance $R = \frac{rV_1}{V_2}$.

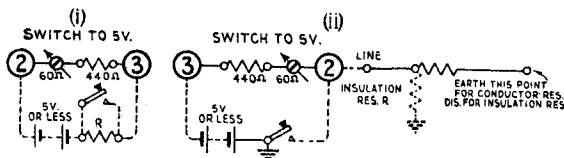

12. 0 to $24,500\Omega$.—Connect up as in (I) or (II). Short-circuit R and note direct reading in divisions = V_1 .

Remove short-circuit and again note reading in division = V_2 .

$$\text{Unknown resistance } R = \frac{500 (V_1 - V_2)}{V_2}$$

The value of R can be ascertained from the Table on Sheet 10 when V_2 is from 18 to 25 divisions or 36 to 50 divisions.

Test No. 11 is more suitable for measuring low resistances.

DETECTOR, No. 4, & COIL, TESTING, No. 1.

RESISTANCE TESTS—continued.

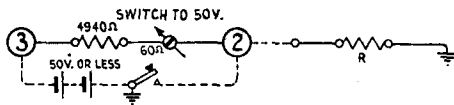

13. 0 to 245,000Ω.—Short-circuit R and note direct reading = V_1 . Remove short-circuit and again note reading = V_2 .

$$\text{Unknown resistance } R = \frac{5000 (V_1 - V_2)}{V_2}.$$

The value of R can be ascertained from the Table on Sheet 10 when V_1 is from 18 to 25 divisions or 36 to 50 divisions.

LINE TESTS.

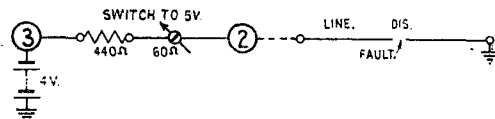

14. *Disconnection.*—Have line earthed at distant end. No deflection on Detector indicates line is disconnected.

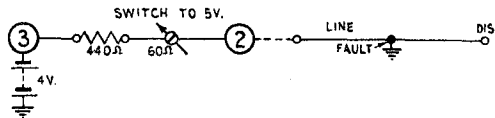

15. *Earth.*—Have line disconnected at distant end. A deflection on Detector indicates line is to earth.

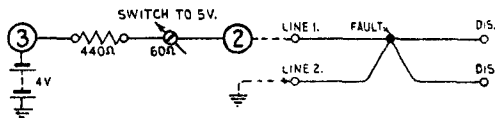

16. *Contact.*—(Exchange testing practice). Have lines disconnected at distant end. Disconnect earth from Line 2 and re-connect. A deflection or an alteration to the deflection on Detector following each connexion of "earth" to line 2 indicates a contact.

DETECTOR, No. 4, & COIL, TESTING, No. 1.

LINE TESTS—continued.

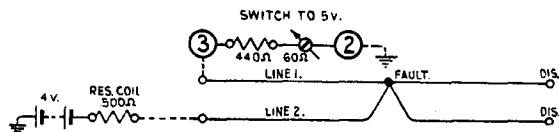

17. *Contact*.—Have lines disconnected at distant end. Disconnect battery and re-connect. A deflection on Detector following each application of the battery indicates a contact.

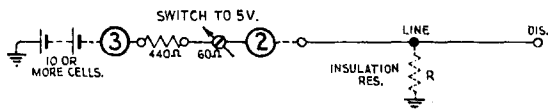

18. *Insulation Resistance*.—Have line disconnected at distant end. Deflection in divisions divided by 5 gives current C in milliamperes.

$$\text{Insulation resistance } R = \frac{\text{Voltage of cells } V \times 1000.}{\text{Current } C \text{ (in milliamps)}} - 500$$

Test 12 or 13 may be taken as an alternative.

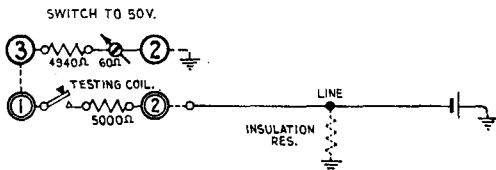

19. *Approximate Voltage at end of Line*.—The reading in divisions multiplied by 2 gives the approximate voltage. This test is suitable for testing voltages on "permanent current" circuits when line resistance not unduly high and leakage normal.

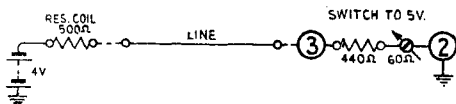

20. *To send or receive a Current*.—Connect power to line through a resistance as shown in order that Loading Coils, etc., may not be damaged by a heavy current.

DETECTOR, No. 4, & COIL, TESTING, No. 1.

PRIMARY BATTERY TESTS.

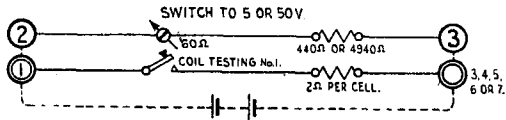

21. *Battery Testing.*—Connect up as in figure with Switch to 5V if voltage less than 5 and Switch to 50V if voltage greater than 5 but less than 50.

Note voltage = V_1 .

Depress Testing Coil Key and note voltage immediately = V_2 .

Keep Key depressed for 1 minute, then release it and note voltage immediately = V_3 .

If the battery is in a satisfactory condition:—

V_3 will be not less than 1 volt per cell.

V_2 will be not less than one half V_1 for No. 0 and No. 1 Leclanché Cells, and Dry Cells. NOT less than one-third V_1 for No. 2A Leclanché Cells. If these conditions are not met, test the separate cells as described in 22.

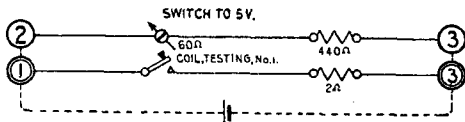

22. *Separate Cell Testing.*—Connect up as in figure.

Note voltage = V_1 .

Depress Testing Coil Key and note voltage immediately = V_2 .

Keep Key depressed for one minute, then release it and note voltage immediately = V_3 .

(1) If, in the case of Leclanché Cells, V_3 be less than 1 volt, clean the cell and change the porous pot or sack element. In the case of Dry Cells withdraw the cell from service.

(2) For No. 0 and No. 1 Leclanché Cells, and Dry Cells, if V_3 be above 1 volt, and V_2 be less than half V_1 , clean Leclanché Cells and refill with fresh Chloride of Ammonium solution.

Withdraw Dry Cells from service.

(3) For No. 2A Leclanché Cells, if V_3 be above 1 volt, and V_2 be less than one-third V_1 clean the cell and refill with fresh solution of Chloride of Manganese or Chloride of Ammonium.

Leclanché Cells must be re-tested after treatment.

The internal resistance of a battery or cell may be calculated from the readings obtained under tests 21 or 22 by using the following formula:—

$$\text{Internal Resistance } r = \frac{S(V_1 - V_2)}{V_2}$$

where S = The Testing Coil Resistance used.

DETECTOR, No. 4, & COIL, TESTING, No. 1.

PRIMARY BATTERY TESTS—continued.

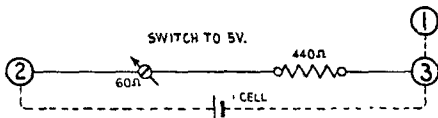

23. Cell Test for use in exceptional cases when Testing Coil not available.—The principle of Test 22 can be applied by connecting up the Detector as above.

To obtain V_2 reading turn switch to 500 mA, thus shunting the cell by 1.5Ω , and restore to 5V after 45 seconds for V_3 reading.

The test must not be applied to more than a single cell.

MISCELLANEOUS TESTS.

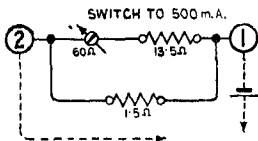

24. Point to Point Testing.—Use Terminals (2) and (1) and a single cell.

Use Test 25 for tapping out on loaded cables.

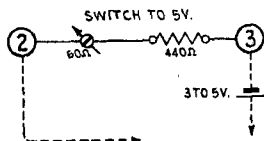

25. Tapping out on Loaded Cables.—Terminals (2) and (3) of the Detector are used in order that a heavy current may not flow to line and damage the Loading Coils.

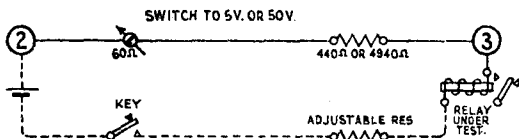

26. Operating Current when less than 10 mA. required. See also Test 39. Connect up as in figure using suitable voltage. Each small division on Detector Scale represents .2mA. The reading in divisions divided by 5 gives current in mA.

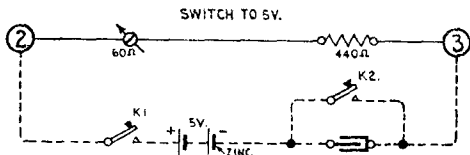

27. To prove a Condenser.—Depress Key K1. If Condenser in working order momentary deflection on Detector will be to right; if disconnected, no deflection; if short-circuited, permanent deflection. Release Key K1 and depress Key K2 to discharge condenser before repeating test.

DETECTOR, No. 4, & COIL, TESTING, No. 1.

MISCELLANEOUS TESTS—continued.

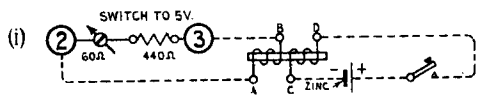

28. Test to determine correct method of joining up Relays, Bridging Coils, etc., that are double-wound, in order to obtain maximum magnetic effect of impedance.—Arrange the connexions so that momentary deflection on Detector is to left when key depressed and to right when key released. When this is the case:—

- Regard Terminal of Coil connected to Terminal (2) of Detector as A.
- " " " " " " " (3) " " as B.
- " " " " " " " " negative pole of Battery as C.
- " " " " " " " " positive " " as D.

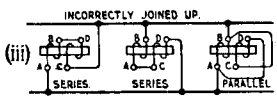
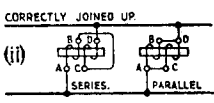

Then if the apparatus under test is joined across a telephone loop in accordance with either arrangement shown in figure (ii) it will offer considerable impedance. If arranged as shown in figure (iii) the ringing and speaking efficiency will be reduced considerably.

This test is also suitable for verifying the direction of the individual windings of a Repeating Coil or Transformer. Figures (iv), (v) and (vi) show the correct methods of joining up such apparatus under different conditions.

Repeating Coil used as a Transformer of a looped circuit.

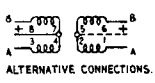
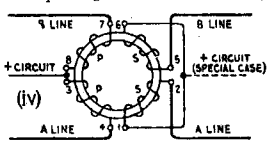

When it is required to take a + circuit from the secondary coil, a Repeating 4006A, or a Transformer No. 4 must be used to obtain the necessary balance.

Repeating Coil used as a Transformer on an earthed circuit.

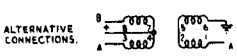
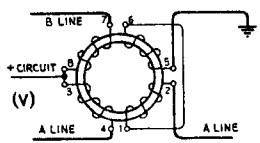

Repeating Coil used as a Bridging Coil.

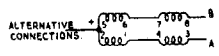
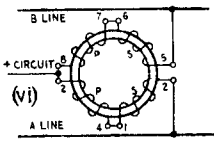

DETECTOR, No. 4, & COIL, TESTING, No. 1.

MISCELLANEOUS TESTS—continued.

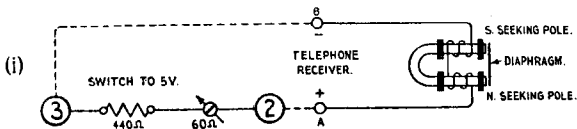

29. To join up a telephone receiver so that exchange current augments magnetic field of its polepieces.—Arrange connexions as in (i) so that momentary deflection on detector is to left when diaphragm removed, and to right when diaphragm replaced.

When this is the case :—

Regard terminal of receiver connected to terminal 2 of detector as A.
 " " " " " " " " 3 " " " B.

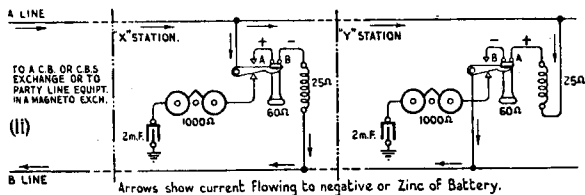

The receiver should then be joined up so that the exchange current flows through its coils from Terminal A to Terminal B as shown in (ii), i.e., Terminal A should be connected to the A line and Terminal B to the B line.

The receiving efficiency of a receiver is considerably reduced when it is joined up incorrectly.

Terminals A and B are marked + and — respectively in modern receivers.

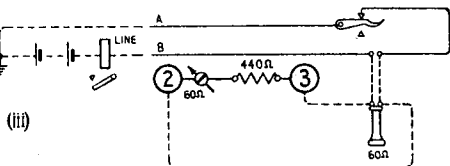

To test receiver in position.—With detector connected as in (iii) obtain reading.

Press down switch hook. If receiver is joined up correctly, kick on the detector will be to left when diaphragm is removed, and to right when diaphragm is replaced. If opposite deflections are observed, reverse receiver leads and repeat test.

DETECTOR, No. 4, & COIL, TESTING, No. 1.

MISCELLANEOUS TESTS—continued.

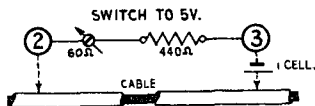

30. To demonstrate existence of induced alternating current in cable sheath.—With connexions shown, a current of about 50 periods will be indicated by the pointer vibrating.

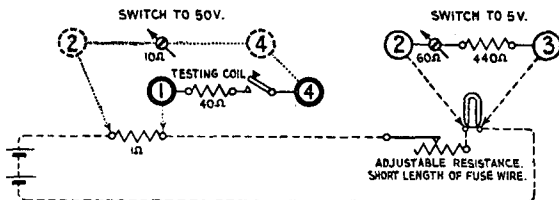

31. Current taken by a switchboard lamp rated at 5 Volts or less.—Adjust E.M.F. and resistance so that reading on Detector agrees with rated voltage of lamp. When this is so, disconnect Detector and connect it as shown across 1Ω resistance.

Note deflection in divisions = D.

Current flowing through lamp in mAs = 10D.

Resistance of lamp when glowing = $\frac{\text{Rated voltage of lamp} \times 100.}{D}$

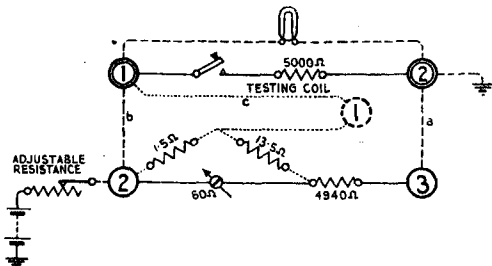

32. Current taken by a switchboard lamp rated from 5 to 50 Volts.—With detector switch to 50V, adjust E.M.F. and resistance so that reading on detector agrees with rated voltage of lamp. When this is so disconnect leads "a" and "b," and make connexion "c," turn Detector switch to 500 mA. scale = C, and depress key of Testing Coil.

Note current shown on the 0.500 mA. scale = C.

Current I in mAs. flowing through lamp = $C - \frac{V}{5}$ where V = Rated voltage of lamp.

Resistance of lamp when glowing = $\frac{\text{Rated voltage of lamp} \times 1000.}{I}$

DETECTOR, No. 4, & COIL, TESTING, No. 1.

MISCELLANEOUS TESTS—continued.

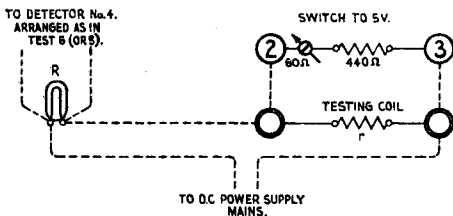

33. To ascertain current flowing through and resistance of a lamp when glowing and power supply is direct current. See also Test 34.—Using Test 3 adjust resistance “r” to give a convenient deflection.

Note deflection in volts = V.

(The value of r to give a deflection of approximately 3 volts can be calculated. Multiply the “rated voltage” of the lamp by 3 and divide the result by the “rated wattage” of the lamp.)

$$\text{Current, C, flowing through lamp in mA} = \frac{1000 \text{ V.}}{r}$$

Using Test 6 (or 5 if suitable), ascertain voltage across lamp = E.

$$\text{Resistance R of lamp when glowing} = \frac{1000 \text{ E}}{C.}$$

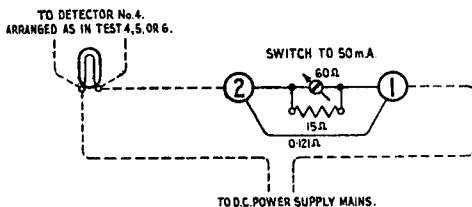

34. In the case of lamps of 75Ω or less resistance or which carry a current of more than 2.5 amps. apply this Test instead of Test 33.

Ascertain current flowing in ampères by Test 9 = C.

Ascertain voltage across lamp by Test No. 4, 5 or 6 = E.

$$\text{Resistance of lamp when glowing} = \frac{E}{C}.$$

To calculate the resistance of a lamp glowing at its rated voltage:—Multiply “rated voltage of lamp” by “rated voltage of lamp” and divide by “rated wattage of lamp.”

To calculate the current carried by a lamp at its rated voltage:—Divide “rated wattage of lamp” by “rated voltage of lamp.”

DETECTOR, No. 4, & COIL, TESTING, No. 1.

MISCELLANEOUS TESTS—continued.

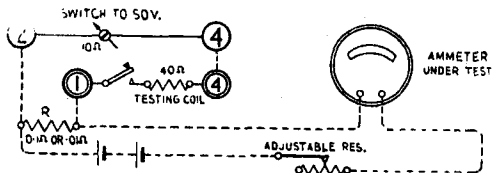

35. To verify accuracy of, or calibrate, an ammeter.—0-10 Amperes. With connexions as shown, the resistance R being 0.1Ω , the ammeter should record 0.2 amp. of current for each division the detector needle is deflected.

0-100 Amperes.—With connexions as shown, the resistance R being 0.01Ω , the ammeter should record 1 amp. of current for each division the detector needle is deflected.

The 0.1 or 0.01Ω resistance can be made from "Wire, Flameproof, $1/12\frac{1}{2}$," 2 six-yard lengths being joined in parallel for 0.1Ω resistance, and 20 six-yard lengths for the 0.01Ω resistance. The wires, when paralleled, should be tested for resistance by making a Wheatstone Bridge test, and shortened if necessary.

36. To ascertain resistance of P.B.X. Power lead.

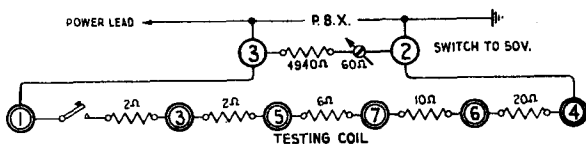

Take detector reading *without* key of coil depressed. Call this V_1 .
 " " " *with* " " " " " " " V_2 .

Release the key and if, owing to some change in load on power lead, the detector does not return to the previous reading for V_1 , the tests should be repeated until consistent results are obtained.

$$\text{Power lead resistance} = \frac{Er(V_1 - V_2)}{V_1 V_2}$$

when E = P.D. of Main Exchange Bus-Bars.

r = Resistance used on Testing Coil No. 1.

V_1 and V_2 = Readings obtained as above.

Refer to Loose-leaf Diagrams T.110 to T.114 for further information regarding the practical application of this test.

DETECTOR, No. 4, & COIL, TESTING, No. 1.

MISCELLANEOUS TESTS—continued.

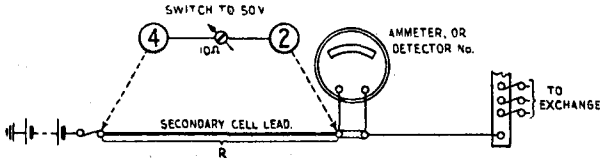

37. To ascertain the resistance of an exchange power lead.—Note the current flowing to the exchange in amperes shown on the Ammeter = C.

At the same time note the reading on Detector, in small divisions = D.

$$\text{Resistance of lead } R = \frac{2D}{1000C}$$

The detector leads should be of very low resistance.

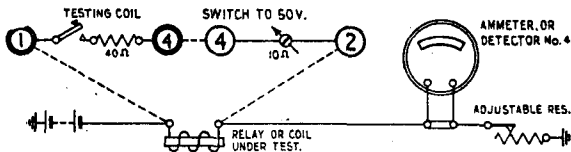

38. To ascertain resistance of a relay, or coil.—If resistance is over 1Ω , use Test No. 10, 11, 12 or 13, but if less than 1Ω , connect up as in figure.

Adjust E.M.F. and resistance so that current of 0.5 to 5 amps. (according to current carrying capacity of coil under test) is indicated on Ammeter.

Note reading on Ammeter, in amps. = C.

At the same time note the reading on Detector in divisions = D.

$$\text{Resistance } R = \frac{D}{100C}$$

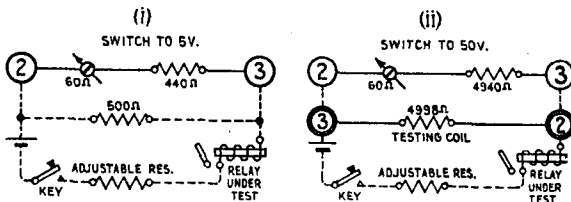

39. Operating current when less than 20 mA. are required.—Connect up as in (i) or (ii) using suitable voltage. The reading in divisions multiplied by 2 and divided by 5 gives current flowing through relay in milliampères.

If less than 10 mA required, Test 26 will give greater accuracy.

DETECTOR, No. 4, & COIL, TESTING, No. 1.

MISCELLANEOUS TESTS—*continued.*

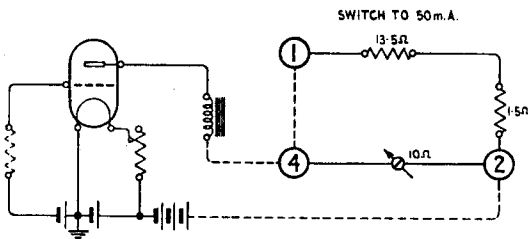

40. To observe current flowing in plate circuit of a thermionic valve.—
- 0–500 mA. Connect Detector in circuit using terminals 2 and 1, switch to 500 mA.
 - 0–50 mA. Connect Detector in circuit using terminals 2 and 1, switch to 50 mA.
 - 0– $16\frac{2}{3}$ mA. Connect Detector in circuit using terminals 2, 4, and 1 as shown in figure. A deflection of 3 divisions = 1 mA.
 - 0–10 mA. Connect Detector in circuit using terminals 2 and 4, switch to 50 V. A deflection of 5 divisions = 1 mA.

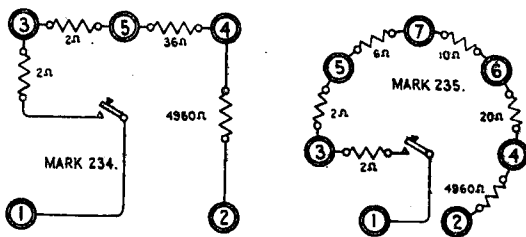

The figures show the Internal Connexions of two types of Coils, Testing, No. 1.

LIST OF Technical Pamphlets for Workmen

(Continued)

GROUP E.

1. Automatic Telephony : Step-by-Step Systems.
2. Automatic Telephony : Coder Call Indicator (C.C.I.) Working.
3. Automatic Telephony : Keysending " B " positions.

GROUP F.

1. Subscribers' Apparatus. Common Battery System.
2. Subscribers' Apparatus, C.B.S. Part I—C.B.S. No. 1 System.
3. Subscribers' Apparatus. Magneto.
4. Private Branch Exchanges—Common Battery System.
5. Private Branch Exchanges—C.B. Multiple No. 9.
6. Private Branch Exchanges—Magneto.
7. House Telephone Systems.
8. Wiring of Subscribers' Premises.

GROUP G.

1. Maintenance of Secondary Cells.
2. Power Plant for Telegraph and Telephone Purposes.
3. Maintenance of Power Plant for Telegraph and Telephone Purposes.
4. Telegraph Battery Power Distribution Boards.

GROUP H.

1. Open Line Construction, Part I.
2. Open Line Construction, Part II.
3. Open Line Maintenance.
4. Underground Construction, Part I—Conduits.
5. Underground Construction, Part II—Cables.
6. Underground Maintenance.
7. Cable Balancing.
8. Power Circuit Guarding.
9. Electrolytic Action on Cable Sheaths, etc.
10. Constants of Conductors used for Telegraph and Telephone Purposes.

GROUP I.

1. Submarine Cables.

GROUP K.

1. Electric Lighting.
2. Lifts.
3. Heating Systems.
4. Pneumatic Tube Systems.
5. Gas and Petrol Engines.

