

OCTARA 32 Phone System

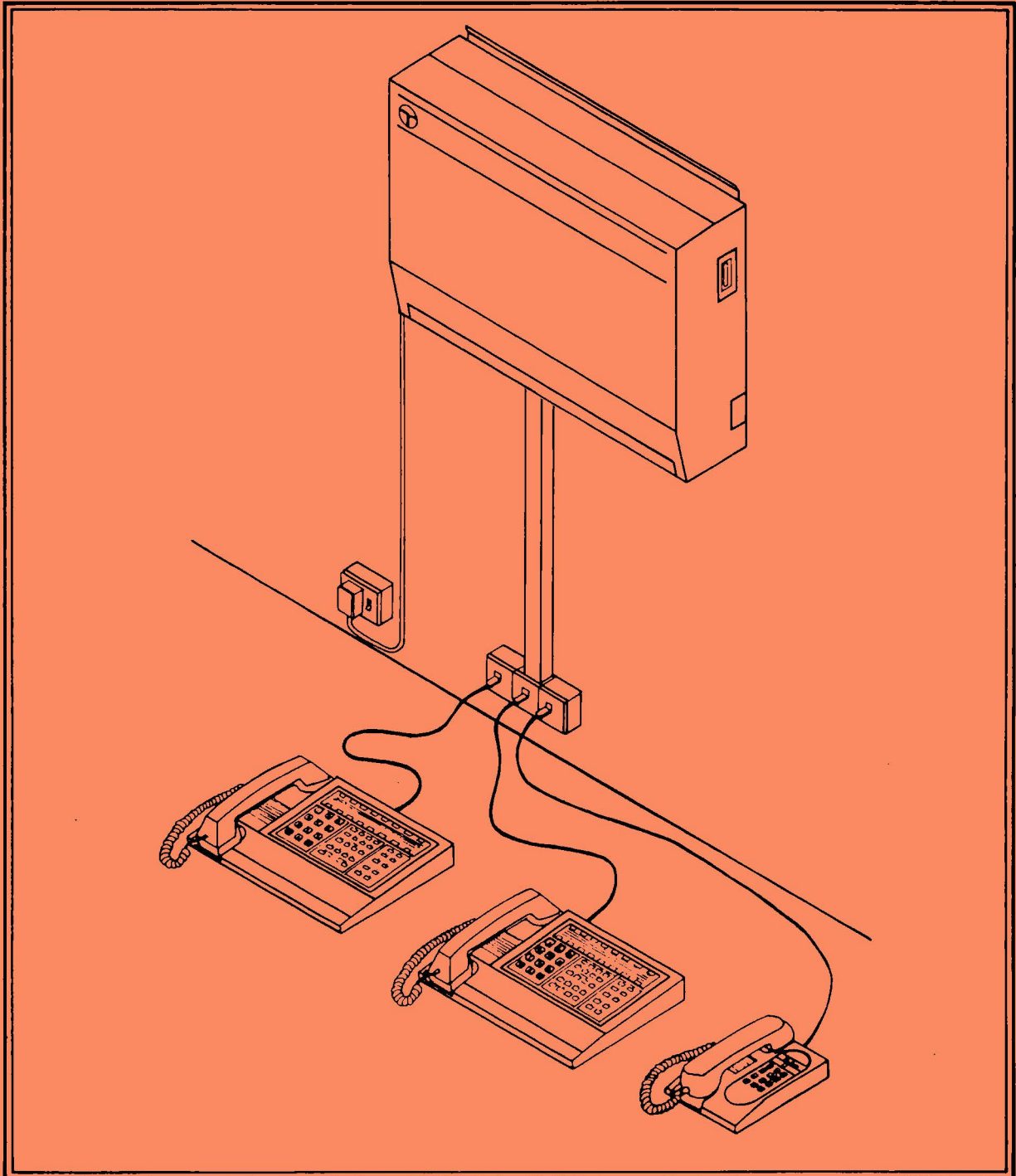

DIFFICULTIES

Technical enquiries and reports of difficulty should be referred to local technical support groups.

Further escalation should be to:-

LCS/Business System Support Unit 1.1.1. (Leeds)
0532 435222

LCS/Business System Support Unit 2.2.3. (London)
01 623 4982

who will liase with:-

LCS/Business System Support Unit 3.2.2. (Maintenance)
01 432 2027

or

LCS/Business System Support Unit 3.4.2. (Installation)
01 357 2807
as necessary.

A646 procedure should be used for reporting design problems and unusual difficulties.

Further copies of this Customer Apparatus Guide Note can be obtained from BTTC Stone, through the BID book.

Included with this book are two overlay cards.

Installation and maintenance training for this product is available on Course No. E2. 0. 470

SECTION 1	GENERAL DESCRIPTION	Page
	1.1 General Description	5
	1.2 Central Control Unit	5
	1.3 Terminal Description	6
	1.4 Power Supply	8
	1.5 Mains Failure	9
	1.6 Approval Conditions	10
SECTION 2	INSTALLATION	
	2.1 Workshop Testing	11
	2.2 Site Installation	11
SECTION 3	CABLING AND TERMINATING	
	3.1 Cable Entry	13
	3.2 Telecoms Earth	13
	3.3 Line Jacks	14
	3.4 Cabling Terminals	14
	3.5 Cabling Power Fail Telephones	14
	3.6 Terminating	15
	3.7 Fit Terminals	15
	3.8 Exchange Lines	16
	3.9 PBX Circuits	16
	3.10 External Music on Hold	17
	3.11 Paging Amplifier	17
	3.12 Printer Connection	17
	3.13 Lightning Protection	17
SECTION 4	ASSEMBLY OF CENTRAL CONTROL UNIT	
	4.1 Facilities Board	20
	4.2 Baseboard	20
	4.3 Extender Boards	21
	4.4 General Checks	22
SECTION 5	SWITCH ON PROCEDURE	
	5.1 Initial Switch On	23
	5.2 Subsequent Switch On	23

		Page
	5.3 New Extensions	23
SECTION 6	BASIC TESTS	
	6.1 Internal Calls	24
	6.2 External Calls	24
	6.3 PBX Calls	24
	6.4 Featurephones	24
	6.5 Power Fail	24
	6.6 Faults	24
	6.7 Pre Connection Inspection	24
SECTION 7	MAINTENANCE	
	7.1 General	25
	7.2 Programming Policy	25
	7.3 Return of Goods Procedure	25
	7.4 Handling Precautions	25
	7.5 Warranty	25
	7.6 Test Conditions	26
	7.7 Faulting	27
	7.8 Power Unit Output	27
	7.9 Terminal Faulting	28
	7.10 Printer Error Messages	29
	7.11 Flow Charts	30
SECTION 8	REPLACEMENT ITEMS	
	8.1 Fuses	34
	8.2 Connectors	34
	8.3 Power Unit Replacement Procedure	35
	8.4 Extender Boards Replacement Procedure	36
	8.5 Baseboard & Facilities Board Replacement Procedure	37
	8.6 Backplane Replacement Procedure	38
	8.7 Terminals	38

SECTION 9	FACILITIES	
9.1	General	39
9.2	Tones	39
9.3	Access to Outside Lines	40
9.4	External Incoming Call	40
9.5	PBX Calls	40
9.6	Making an Internal Call	41
9.7	Receiving an Internal Call	41
9.8	Abbreviated Dialling	42
9.9	Redial	42
9.10	Hold	43
9.11	Enquiry	44
9.12	Transfer	44
9.13	Conference	44
9.14	Divert	45
9.15	Call Redirect	45
9.16	Pick-up	46
9.17	Answer Page	46
9.18	Camp	47
SECTION 10	FEATUREPHONE FACILITIES	
10.1	Shift	48
10.2	Page	48
10.3	Intrude	48
10.4	Do Not Disturb	48
10.5	TX23	49
10.6	TX25	49
SECTION 11	ADDITIONAL FACILITIES	
11.1	Telephone Receptionist	50
11.2	Night Service	50
11.3	Manager Secretary	51
11.4	Pick-up Groups	51

SECTION 12 PROGRAMMING

12.1	General	52
12.2	Program Extension	52
12.3	Initial Programming	52
12.4	Changing Programming Extension	52
12.5	Subsequent Programming	52
12.6	Locating Programming Extension	52
12.7	Exit Programming	52
12.8	Outside Lines	53
12.9	PBX Access	54
12.10	Call Barring	55
12.11	List of Permitted Numbers	56
12.12	Classes of Service	57
12.13	Altering an Existing or Creating a New Class of Service	59
12.14	Overlay Cards	60
12.15	Allocating Classes of Service to Extensions	60
12.16	Manager Secretary	61
12.17	Pick-up Groups	61
12.18	Telephone Receptionist	61
12.19	Changing Extensions	61
12.20	Erasing an Extensions Programming	62
12.21	Printer	62
12.22	System Abbreviated Dialling	63

SECTION 1: GENERAL

General Description

The Octara 32 Digital Phone System is a stored-program controlled telephone system with a maximum capacity of 10 Exchange lines and 32 Extensions. The control unit is a wall mounted cabinet containing Processor, Line-cards, Modular power supply and the box connection terminals. Each telephone terminal is connected to the Central Control Unit using 4 wires, which convey both speech and signalling information in a digital form.

Due to the all digital nature of the design the system is not limited in the number of simultaneous calls which can take place.

System Capacity

10 Exchange lines
32 Extensions

In its basic form the system is equipped for 2 exchange lines and 6 extensions. The basic capacity may be increased by adding up to 3, 2+6 extension cards, to give system sizes of 4+12, 6+18, and 8+24. Finally a 2+8 extension card can be added, to give the maximum capacity of 10+32.

Central Control Unit

Wall mounted: 24.3" (62cm) wide
18.1" (46cm) high
6.1" (15.5cm) deep

Weight: 14Kg (31 lbs)

Terminal Description

The TX 23 Octara terminal is a digital featurephone offering a large number of facilities. These include status indicators (LEDs) and a monitor amplifier.

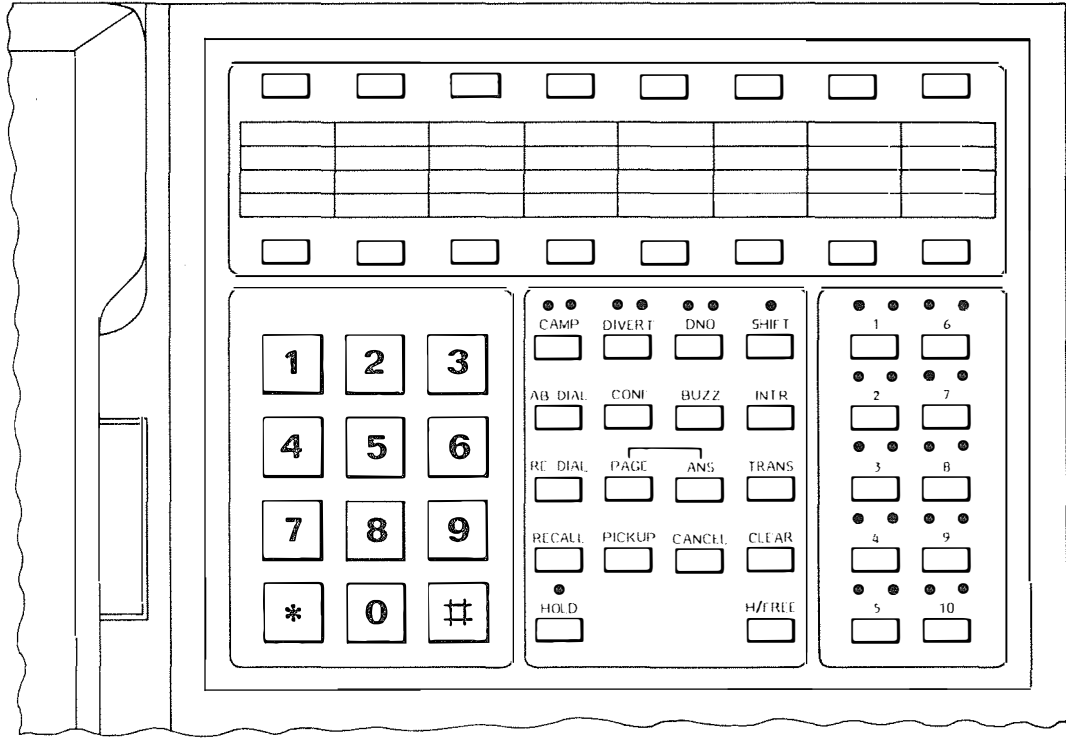

The TX 25 Octara terminal has all the facilities of the standard terminal with the addition of a full loudspeaking capability.

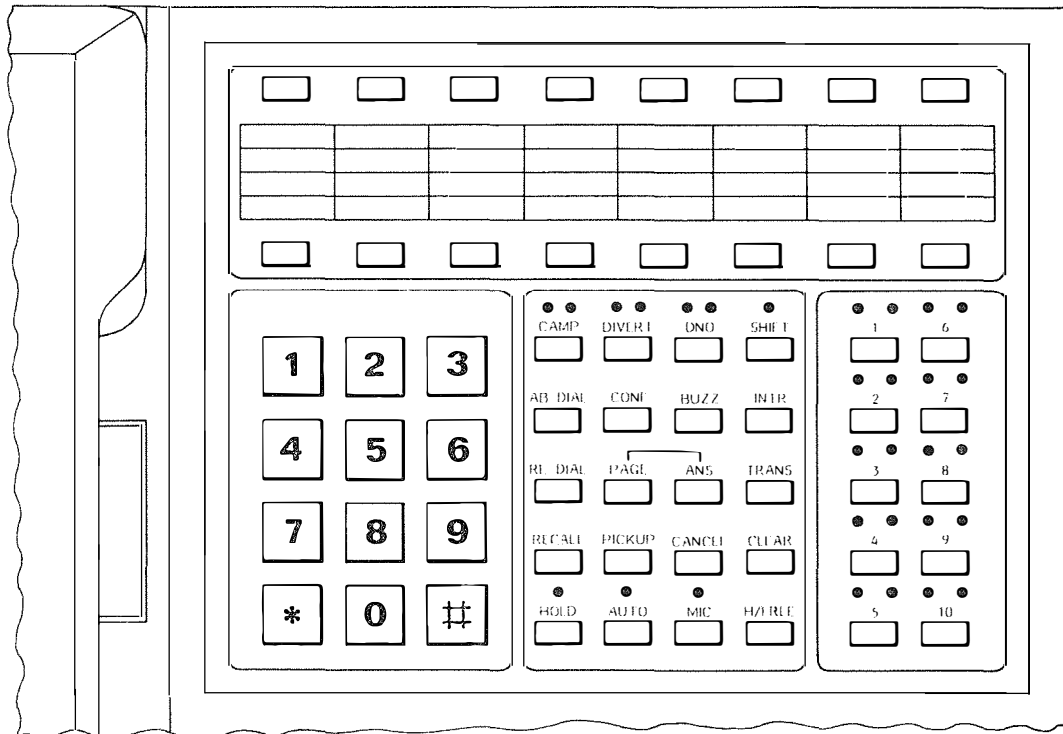

Facilities on the TX23/25 are normally accessed by single key operations.

The TX 21 Octara terminal is also available, which offers reduced facilities at lower cost.

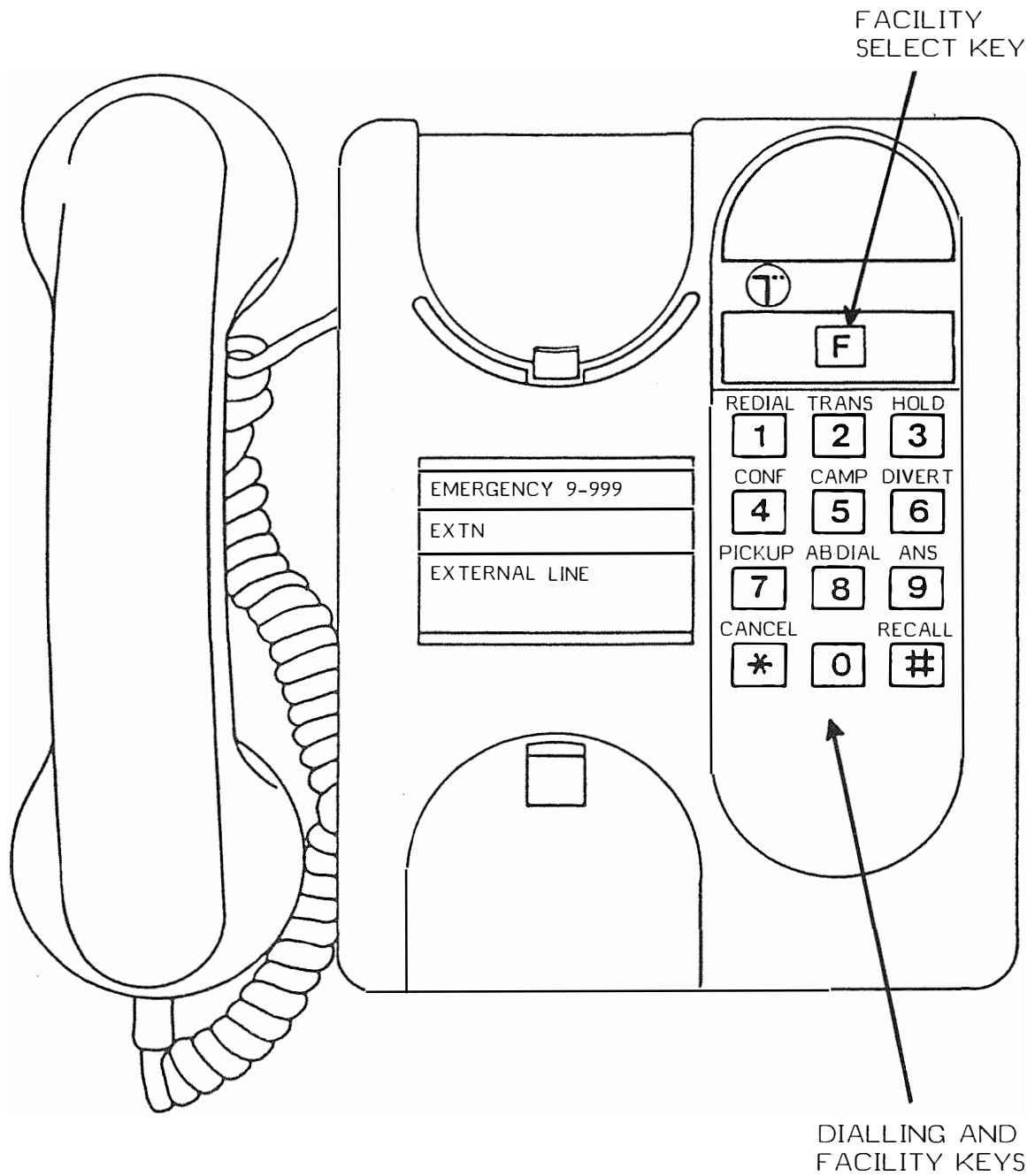

Facilities on the TX21 are accessed after pressing the 'F' key, prior to each function key.

Power Supply

The power supply unit for the Octara 32 is mounted within the main CCU.

The system is powered from a 250 volt 50Hz mains supply, fused at 13 amps within the mains plug (via a 3 metre mains input lead). Additional protection is given by a 5 amp slo-blo fuse fitted to the power supply unit. Individual 10 amp fuses are provided for:

- 75 volt supply
- +5 volt supply
- 5 volt supply.

These fuses can be changed after removal of the main unit cover.

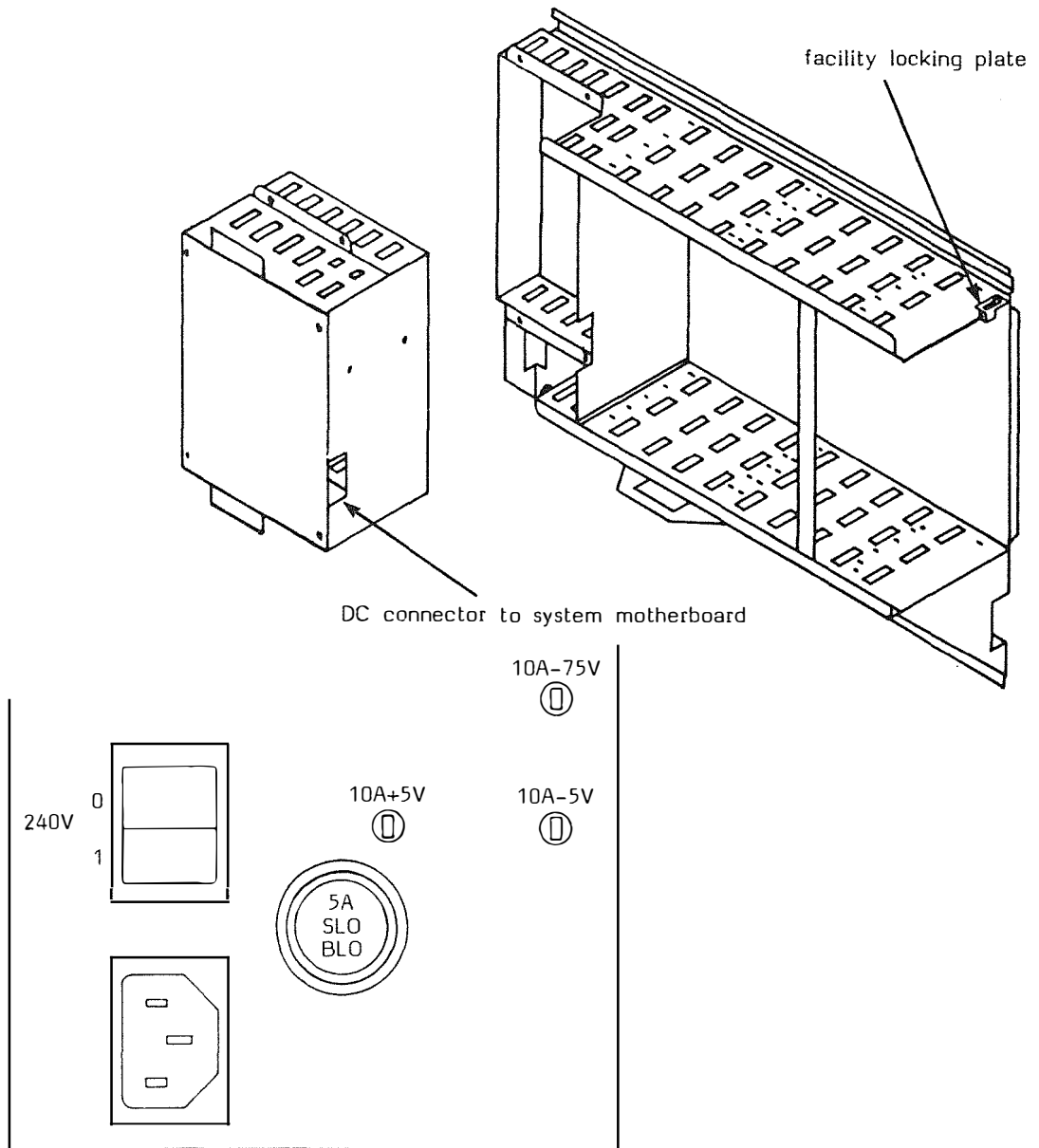

Modular power supply and fuse/switch panel

Mains Failure

In the event of mains failure, up to 6 exchange lines are diverted direct to independently cabled power fail LJU's into which the customer may plug standard telephones (ie loop disconnect or DTMF). The system will restart automatically when the power is restored, with all the programming retained in the memory.

The memory is retained for up to 2 weeks during power failure by a battery which is continuously charged from the mains.

Certain trunks are automatically connected to power fail line jacks under mains failure.

For a fully equipped system the following power fail connections are possible.

Trunk	Power Fail
1	Yes
2	Yes
3	Yes
4	No
5	Yes
6	No
7	Yes
8	No
9	Yes
10	No

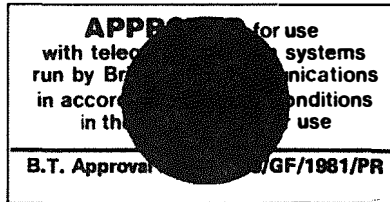

Approval Conditions

These are fully described in the Private Exchange Master List (PXML/3.SCR 0006), which is provided with each system. Only the equipment specified in the PXML can be provided.

The following details form part of PXML/3.SCR 0006.

- a) Power fail facilities must be provided on the basis of one Line Jack Unit 2/1A, for every 5 exchange lines.
i.e. 1-5 exchange lines one power fail line jack
 6-10 exchange lines two power fail line jacks.
- b) Extension cabling must be for the specific use of the system (dedicated cabling).
- c) Each Octara 32 terminal must be connected to the system by use of the Line Jack Unit 2/3C.
- d) Exchange lines must be connected via a Network Terminating and Test Point before connection to the Octara 32.
- e) The system must be subjected to a Pre-Connection Inspection (PCI), before connection to the Public Switched Telephone Network (PSTN).
- f) Printer Equipment which conforms to BS 6301 may be connected via the V24 connector.
- g) AC15C two wire circuits, using Signalling Units 53A and 54A may be provided.

SECTION 2: INSTALLATION

Workshop Testing

Basic tests should be carried out on the OCTARA 32 as detailed on Page 19 before the equipment is installed in customers premises. It is recommended that the system is assembled and tested in the workshop, before it is removed to site. The normal installation procedure for assembly of the unit should be followed, with temporary connections made for trunks and extensions. The mains supply should be switched on overnight to charge the nickel cadmium battery.

After testing, the equipment should be replaced in the correct packing material, for transportation to customers premises.

Site Installation

The installation of the Octara 32 should be undertaken in the following sequence.

Siting

Determine the site for the wall-mounted CCU, which should be within 3 metres of a mains supply with at least 1/2 metre clearance on the righthand side allowed for removal of slide in cards. Space should also be allowed on the left-hand side, to allow access to fuses and mains input lead.

Space above and below the unit should be allowed for ventilation.

Consideration should be given to siting the unit at a convenient height for ease of maintenance.

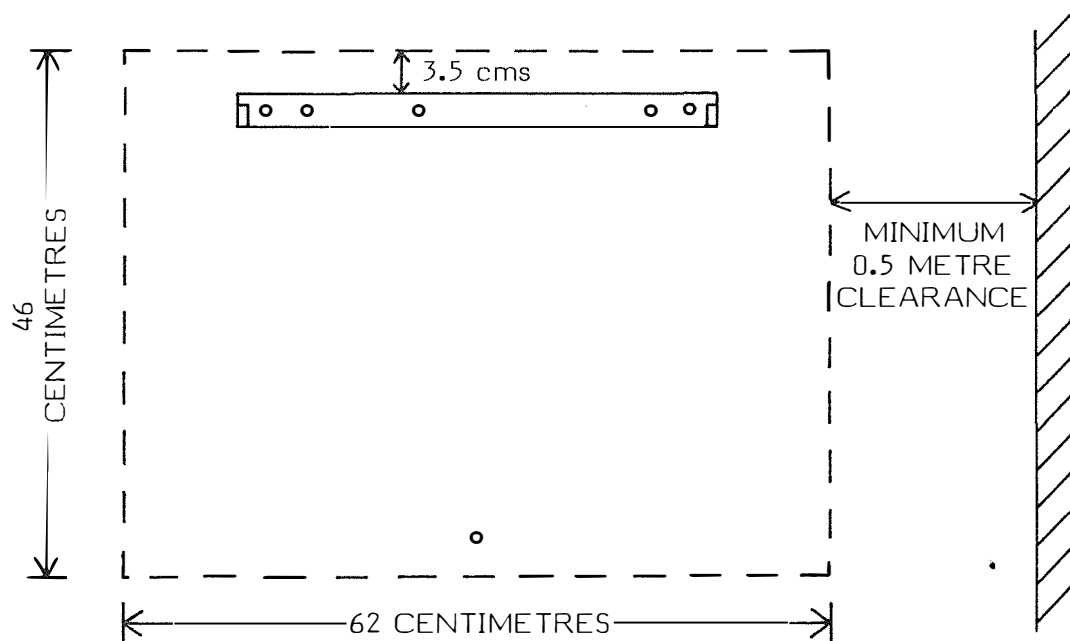

Removal of Power Supply Unit

Remove the power supply unit in order to reduce the weight of the central control unit for lifting into position.

Unscrew the 4 power supply unit retaining screws, and move the unit slightly forward and to the left. Unclip the DC connector which connects the power supply unit to the central control unit and remove unit. See fig on page 8.

Fixing the CCU to the wall

- 1) Using the template provided, mark the positions of the fixing screws onto a suitable wall.
- 2) Taking care that hidden services are not encountered, drill and plug wall.
- 3) Fix mounting bracket to wall. See fig on page 11.
- 4) Lift CCU onto mounting bracket.
- 5) Fit the lower fixing screw to the CCU.
- 6) Adjust jacking bolts to touch the wall, to ensure rigidity of the unit.

Replace Power Supply Unit

The replacement of the power supply unit is the reverse of the removal procedure.

CABLING AND TERMINATING

Cable Entry

Three cable entry points are provided in the CCU cover. These entry points will accept Trunking 2A, with unused positions covered by slide in panels provided with CCU.

Provide Telecoms Earth

Provide a telecoms earth to either of the earth terminals sited within the CCU, using wire earthing 9141/1W cream or wire earthing 9142/1W grey. See fig below.

MAXIMUM VALUE NOT TO EXCEED 4 OHMS

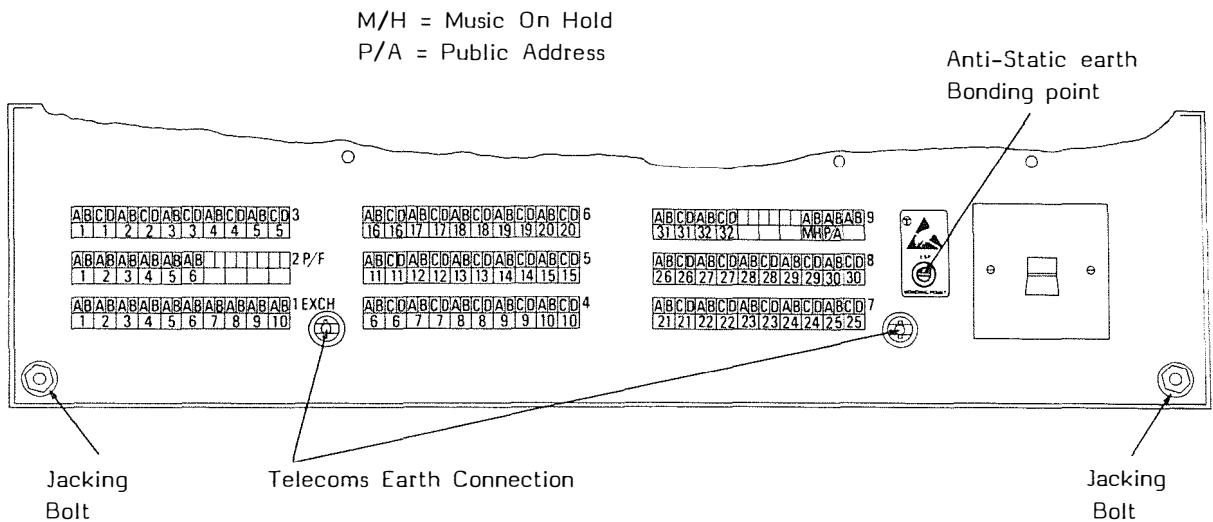

Line Jacks

Octara terminals are pre-fitted with line cords which must be connected to Line Jack Units 2/3C

Power fail telephones are standard telephones and CANNOT be connected to Line Jack Units 2/3C

Cabling Terminals

Cable from the CCU Strips Connection 237A to the extensions Line Jack Units 2/3C.

Extensions should not exceed the following cabling limits, using Cable Equipment 2000 series.

TX23 and TX 25:
700 metres 0.5mm copper wire.

Max Loop Resist 137 ohms

TX 21:
1500 metres 0.5mm copper wire.

Max Loop Resist 300 ohms

Cabling Power-Fail Telephones

Cable from the CCU Strips Connection 237A to the power fail Line Jack Units 2/1A.

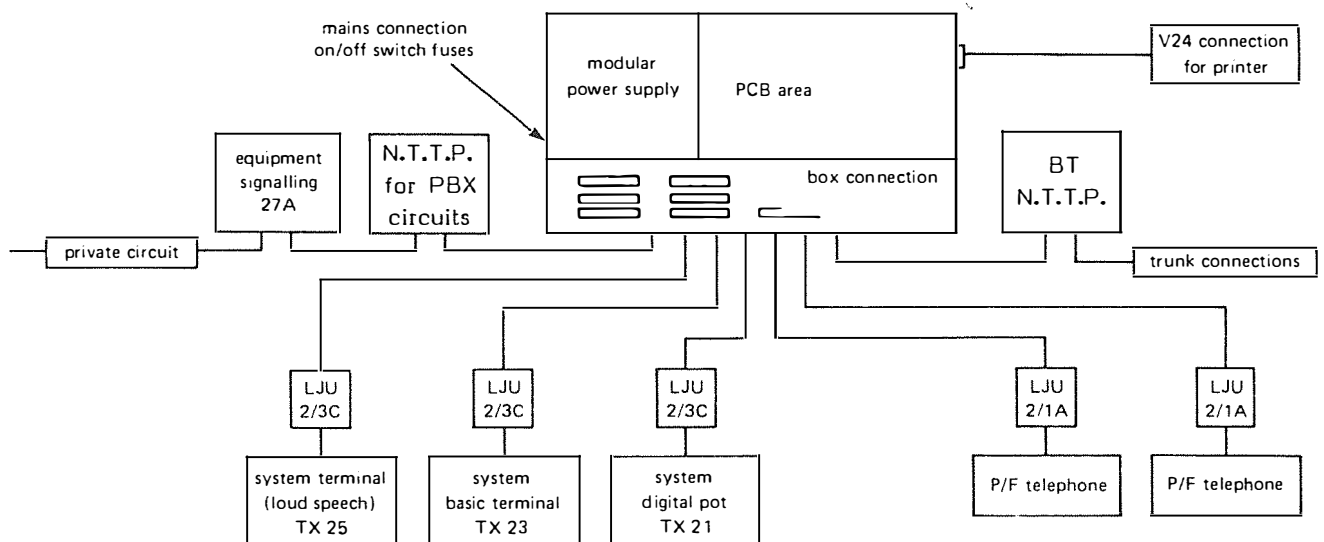

Pictorial Diagram

Terminating

Terminate both ends of extension cables, including power fail as shown below.

IT IS IMPORTANT THAT EACH CONDUCTOR IS TERMINATED AS SHOWN, SINCE REVERSALS CAUSE SYSTEM MALFUNCTION.

TERMINATIONS FOR OCTARA LINE JACK UNITS

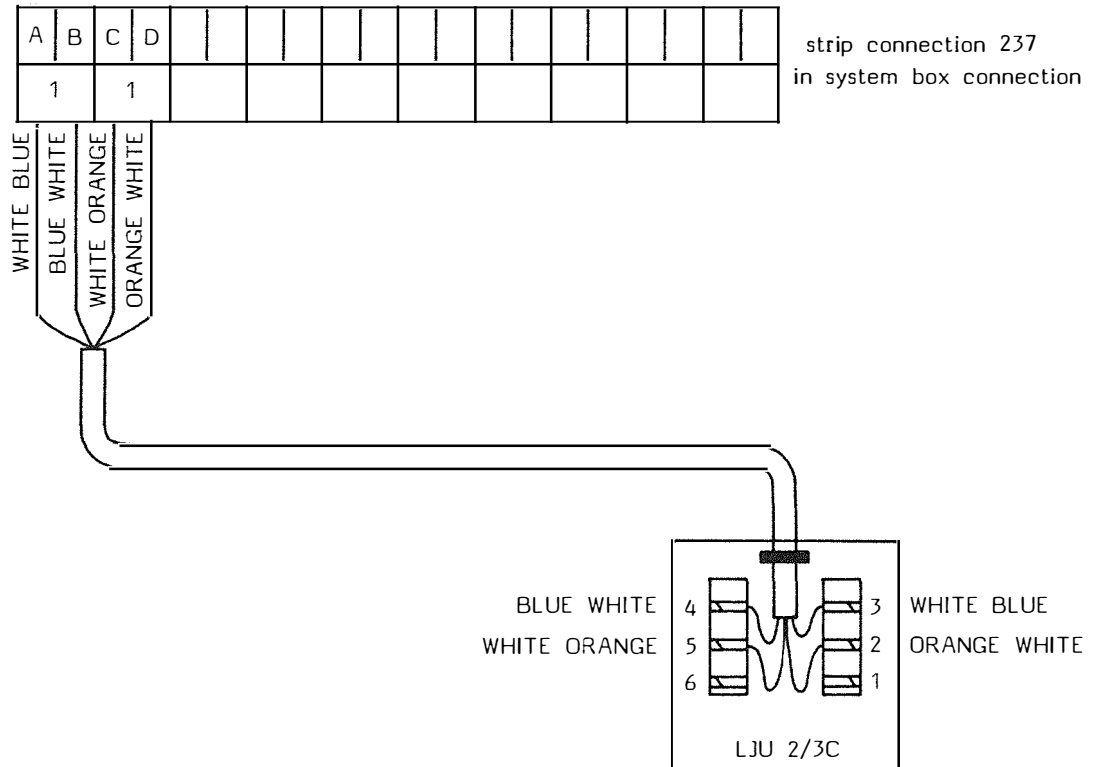

TERMINATIONS FOR POWER FAIL LINE JACK UNITS

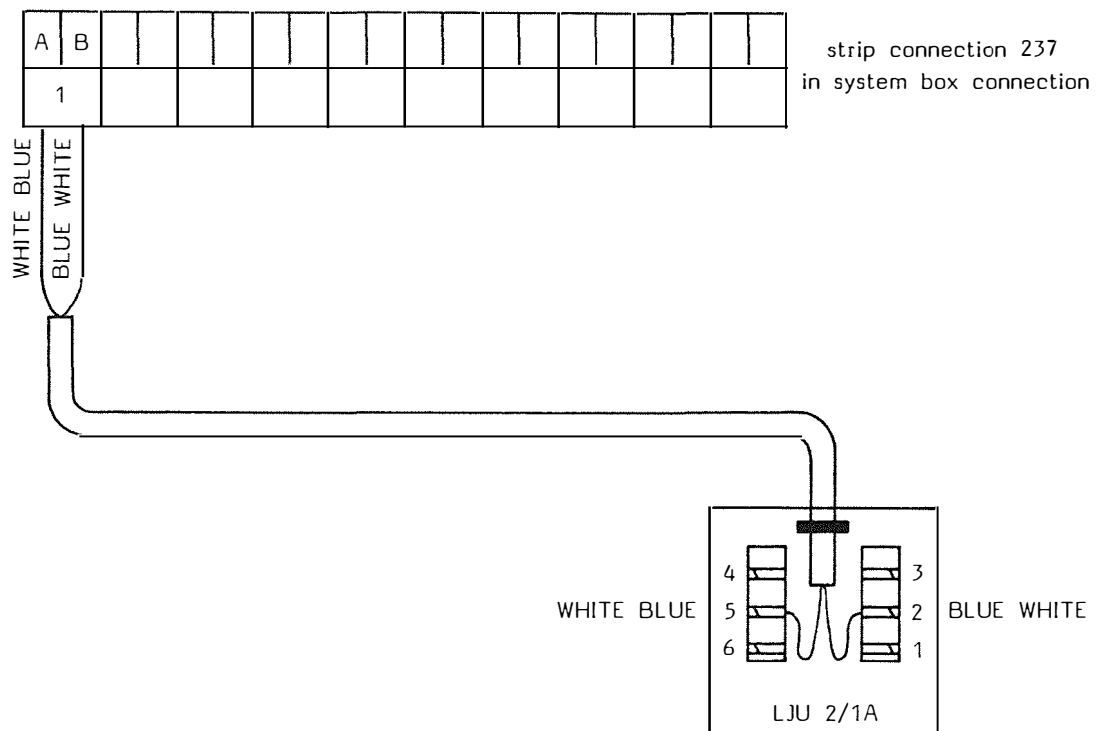

Fit Terminals

Connect telephones to Line Jack Units ensuring that a 'featurephone' (TX23 or TX25) is fitted at extension No 1.

Exchange Lines

Exchange lines are cabled from the CCU to the Network Termination and Test Point (Box Connection 252A).

PBX Circuits

Inter PBX circuits may be provided in place of an exchange line. These are provided using signalling units 53A and 54A, fitted within Signalling Equipment 27A.

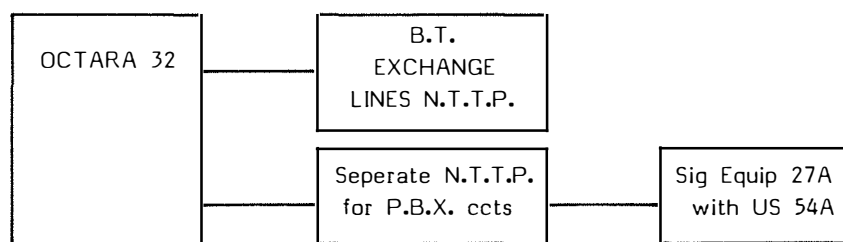

Connection of Octara 32 to a B.T. Private Circuit

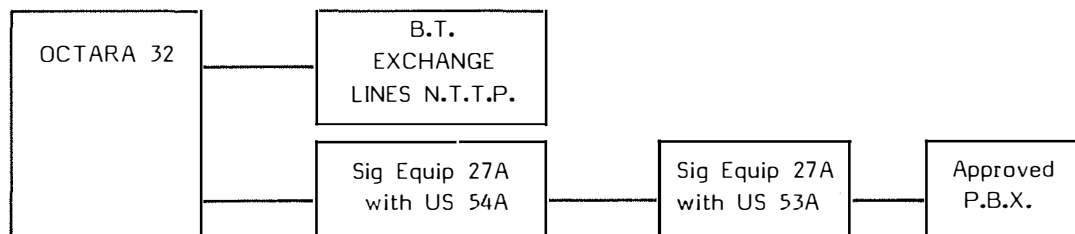

Connection of Octara 32 to a customers P.B.X.

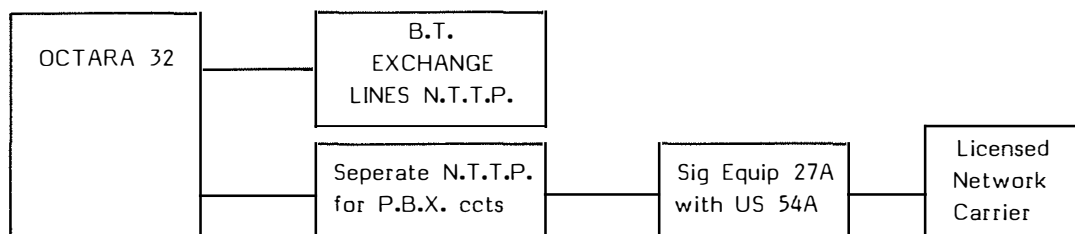

Connection of Octara 32 to a Licensed Network Carrier

Signalling Unit wiring details are contained in diagrams SA/SAW103240 and SA/SAW103250

External Music on Hold

Cable from the strips connection within the CCU (MH) to a block terminal, which should be fitted near to the external music source. This source should have a typical impedance of 7.5k ohms and an output level of -15dBV (max -2dBV).

Paging Amplifier

Cable from the strips connection within the CCU (PA) to a block terminal, which should be fitted near to the external amplifier. This should be matched to 600 ohms impedance, with a sensitivity of -13dBm.

Printer Connection

A printer (which conforms to the PXML) may be connected to the V24 connector (25 pin 'D' type), which is situated on the right hand side of the CCU.

- Pin 1 equipment earth (if required)
- Pin 2 data output
- Pin 5 CTS input - requires a clear-to-send signal from the printer to allow data to be sent.
- Pin 7 signal earth

Lightning Protection

If required, lightning protection should also be fitted at the Network Terminating and Test Point.

Gas Discharge tubes can be fitted to a protector mounting 5B which connects to the strips connection 237 as shown below.

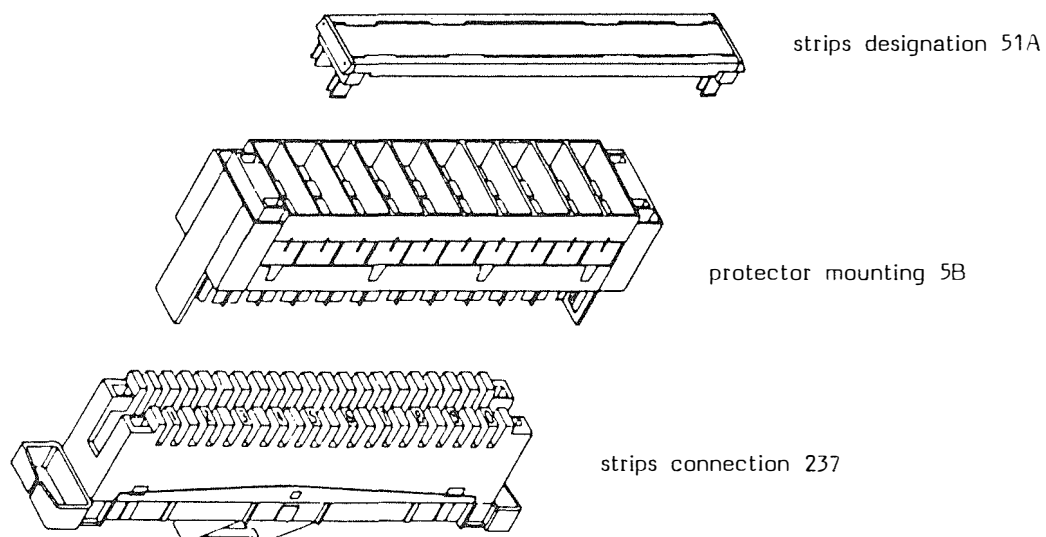

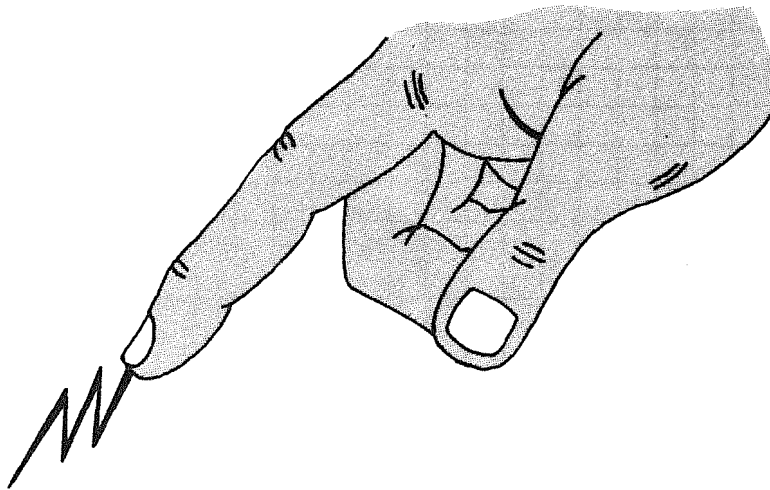

WARNING:

At this stage “electro-static” precautions should be taken for the remainder of the assembly procedure.

Electro-static precautions must also be taken whenever any future work upon the control unit is undertaken.

The ESP bonding point is shown on page 13

ASSEMBLY OF THE CENTRAL CONTROL UNIT (C.C.U.)

The wall mounted central control unit is equipped with 5 positions for the provision of slide in units.

The baseboard with facilities board must be slotted into position No.1. Positions 2 - 4 are reserved for growth with 2+6 extender cards, and position No.5 must only be fitted with a 2+8 extender card.

If cards are not fitted in the above order the system will re-configure to exclude unused positions. If a card is subsequently fitted to these positions, extensions will require number changes.

CHANNEL NO.	SLIDE IN CARD	SYSTEM CAPACITY
1	baseboard	2 + 6
2	2+6 extender card	4 + 12
3	2+6 extender card	6 + 18
4	2+6 extender card	8 + 24
5	2+8 extender card	10 + 32

Before inserting a card check that the connector and card pins are not bent.

Each slide in unit is slotted into a channel for location purposes. Do not slide the unit into the backplane before its earth protection connection is completed. After connection of the earth, the unit is pushed firmly into the backplane socket taking care that the card is correctly aligned.

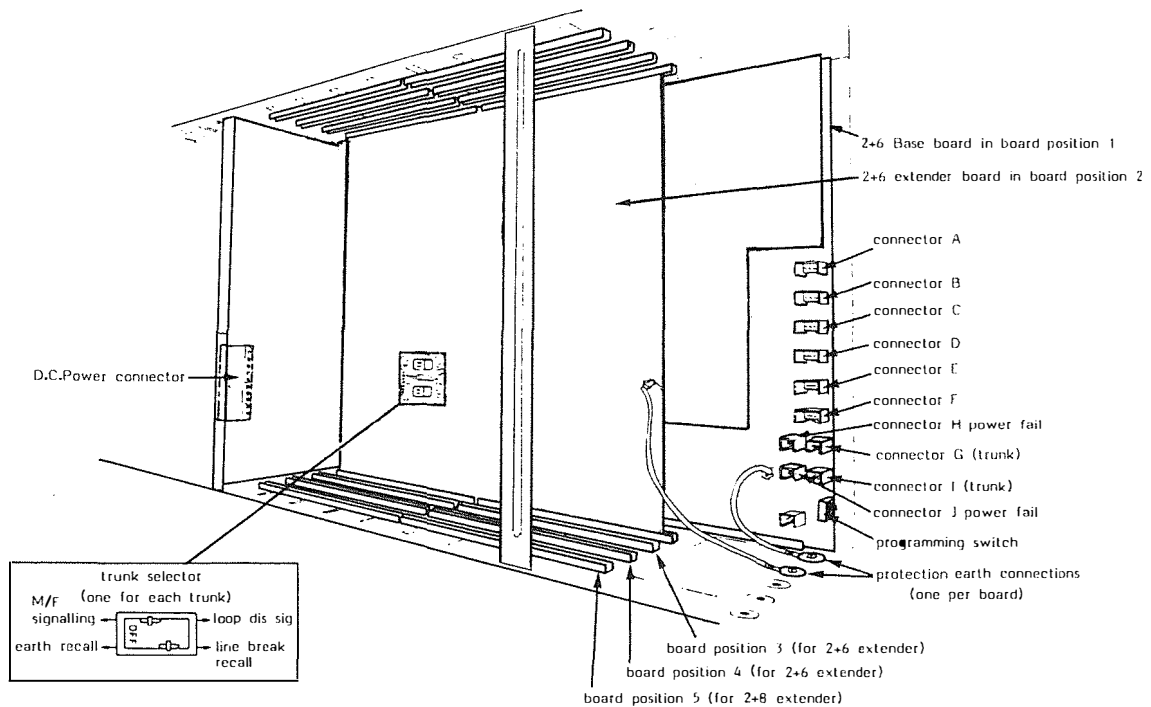

Facilities Board

Assemble the facilities board onto the baseboard taking care to ensure correct alignment and full insertion of connectors. Music on Hold and printer links should be set on the facilities board as shown below.

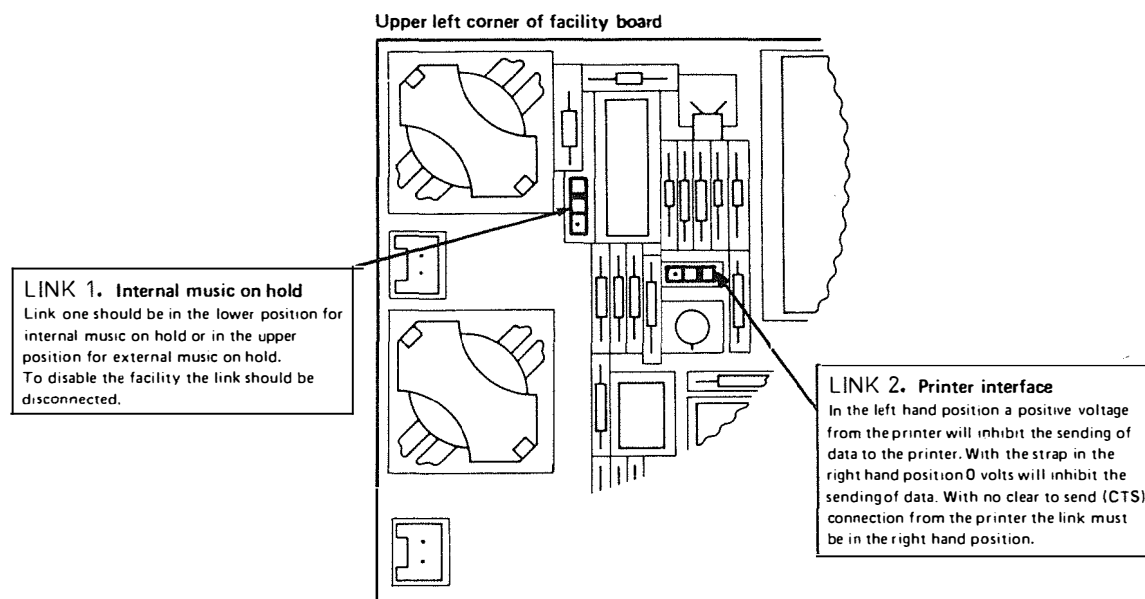
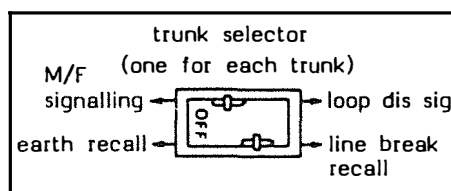

Fig Music on Hold and printer connection links

Baseboard

After assembly of facilities board, locate in channel No 1. Complete protection earth connections and slide unit into position firmly. See fig on page 19. Fix the facilities board locking plate.



Trunk and PBX selector switches

Set trunk 1 and 2 exchange conditions on baseboard trunk selector switches, (loop or DTMF).

Set the PBX recall switches and if PBX trunks are not fitted, the switches must be placed in the OFF position.

Release No.1 tied back wiring harness and connect to base and facilities board.

Connections to PCB's

Each printed circuit board is connected to the strips connection 237 by a wiring harness, which is given a numerical identification. Individual connectors on the harness are identified by letters, which correspond with connector socket labels on the printed circuit board. If difficulty is experienced inserting a connector, the assembly of the connector should be checked, against other connectors.

Extender Boards

Locate the first 2+6 extender board in channel No 2. Make protection earth connection and slide unit into position firmly.

Set trunk 3 and 4 exchange conditions on extender board trunk selector switches (loop or DTMF).

PBX recall switches should be set, and if PBX trunks are not fitted the switches must be placed in the OFF position.

Release No 2 tied back wiring harness and connect to extender board. Repeat sequence for 2+6 extender boards No 3 and 4.

If a 2+8 extender board is to be provided, this must be fitted in channel No 5, as additional connections are only provided for position number 5 in the harness.

NOTE If the system is extended, boards MUST NOT be inserted with the mains connected.

General Checks

- 1) Check that the correctly rated fuses are fitted for, mains plug and power unit input/output.
- 2) Connect mains lead, ensuring that socket and CCU switches are in the off position.
- 3) Check that a 240 volt warning label is fitted to the power unit.
- 4) Check that the earth warning label for board removal, is fitted to the CCU.
- 5) Check that the telecoms earth is correctly connected.
- 6) Ensure that the earth protection connection is securely fitted for each board.
- 7) Check that the wiring harness connectors to each slide in board are firmly fitted.
- 8) Check that the facilities board locking plate is secured.
- 9) Confirm that the wiring of extensions both at the CCU and at each line jack is correct.

SWITCH-ON-PROCEDURE

Initial Switch-on

- 1) Place the programming switch in the up position as shown below. With the cover fitted, access to the programming switch is gained via a cover on the right of the control unit.

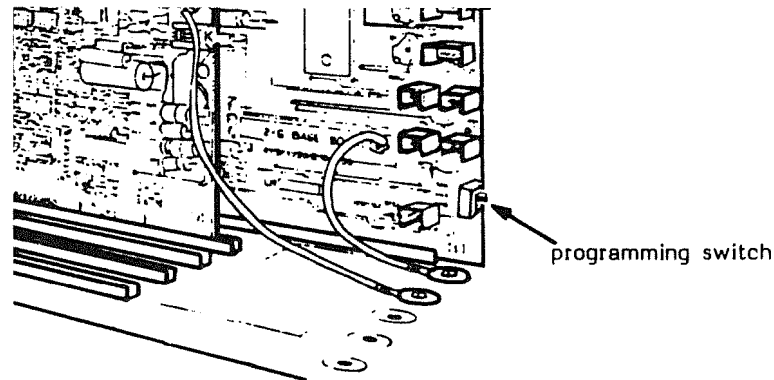

- 2) Switch on at the mains socket, then at the CCU. The switch at the side of the CCU should now be illuminated.
- 3) Place the programming switch in the down position.

After switch-on a delay of 30 seconds should be allowed, to give the system time to initialise.

Subsequent Switch-on

If it is necessary to switch the power off, after the system has been programmed, the programming switch must be left in the down position to retain memory.

New Extensions

Each new terminal fitted, will require lifting of the handset and then replacement, to initialise after switch on.

After a delay of 30 seconds the system will include this extension.

BASIC TESTS

Carry out basic tests to ensure system is functioning.

These tests should be carried out before the unit is installed in the customers premises, and also after the installation.

Internal Calls

Check that each Octara telephone can make and receive internal calls.

External Calls

Temporarily connect an exchange line to trunks 1 and 2.

Check that using trunks 1 and 2, each Octara telephone can make an outgoing call, and receive an incoming call.

Repeat the above procedure for each trunk with card provision.

PBX Calls

Check that each Octara telephone can make and receive a call using each PBX trunk provided.

Featurephones

Check that the TX25 will work in 'handsfree' mode.

Check that the TX23 will work in 'monitor' mode.

PowerFail

Switch off the mains supply and after a delay of 10 seconds, check that power fail telephones can make and receive external calls.

Faults

If for any reason the above tests fail, refer to the faulting section on page 27.

Pre-Connection Inspection

Before a pre connection inspection takes place, all temporary exchange line connections should be removed at the Network Terminating and Test point.

P.C.I. staff are responsible for permanent connection of exchange lines.

MAINTENANCE

General

The OCTARA 32 is a modular key telephone system, which allows on site maintenance by replacement of faulty units.

Programming Policy

Customers system programming is not carried out by Installation or Maintenance staff.

If a fault occurs which results in loss of programmed information, the customer should be asked to re-programme the system. This to be carried out after the system has been restored to the 'Initialised' state. However, it may be necessary to offer the customer basic assistance.

Return of Goods Procedure

A completed A8807A form should accompany faulty items, which should be returned to Area Stores, using the maintenance exchange procedure. The packing material from the replacement unit should be used for the return of faulty parts.

Handling Precautions

Full precautions against electro-static degradation must be taken whilst faulting. It is important that these precautions also apply to faulty items, as identification of original fault may be obscured. Any paperwork including the A8807A fault report, should not be placed INSIDE anti-static bags.

Printed circuit boards are fragile and care should be taken whilst handling them.

Warranty

The system carries a 12 month warranty from Merlin.

Test Conditions

Exchange line test conditions are normal capacitance 'A' leg to 'B' leg.

Extensions must not be tested by use of meters or buzzers due to the all digital nature of the equipment.

A test cord is fitted within the central control unit. This allows the testing of extension telephones and extension PCB circuits for faulting purposes.

The plug of the test cord is inserted into the strips connection of the extension circuit to be tested, and an OCTARA terminal plugged into the line jack.

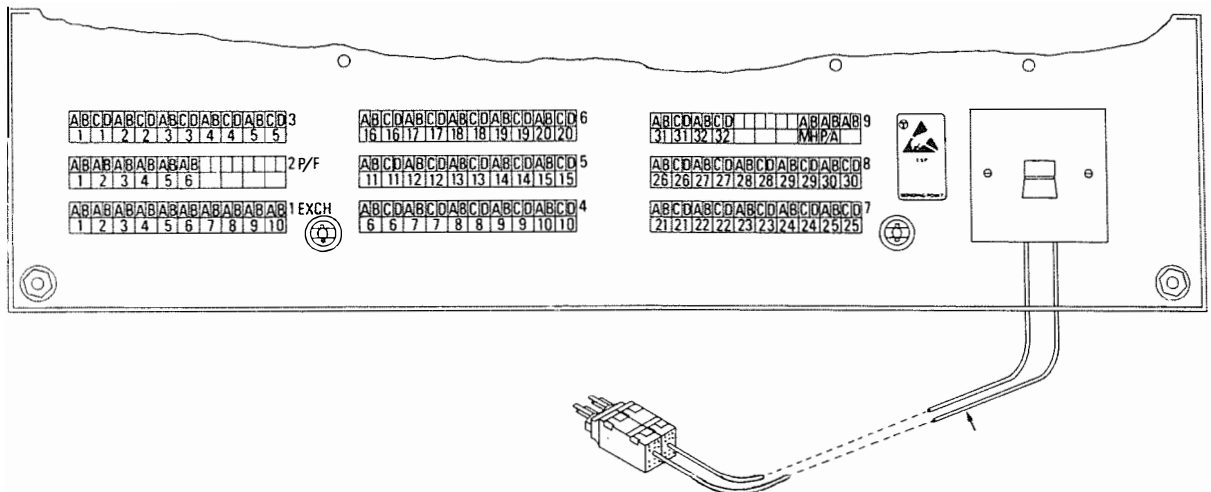

The test cord plug must not be inserted into the exchange lines or power fail connections, as damage will result.

Faulting

Faulting should be carried out in a logical manner by use of the flow charts.

If more than a single fault is suspected on the system, then circuit positions on slide in cards should be examined. Several faults may group to a single slide in card fault.

System size	PCB slot	Board size	Extension No.	Trunk No.
2 + 6	1	2 + 6 (B)	1 2 3 4 5 6	1 2
4 + 12	1	2 + 6 (B)	1 2 3 4 5 6	1 2
	2	2 + 6 (E)	7 8 9 10 11 12	3 4
6 + 18	1	2 + 6 (B)	1 2 3 4 5 6	1 2
	2	2 + 6 (E)	7 8 9 10 11 12	3 4
	3	2 + 6 (E)	13 14 15 16 17 18	5 6
8 + 24	1	2 + 6 (B)	1 2 3 4 5 6	1 2
	2	2 + 6 (E)	7 8 9 10 11 12	3 4
	3	2 + 6 (E)	13 14 15 16 17 18	5 6
	4	2 + 6 (E)	19 20 21 22 23 24	7 8
10 + 32	1	2 + 6 (B)	1 2 3 4 5 6	1 2
	2	2 + 6 (E)	7 8 9 10 11 12	3 4
	3	2 + 6 (E)	13 14 15 16 17 18	5 6
	4	2 + 6 (E)	19 20 21 22 23 24	7 8
	5	2 + 6 (E)	25 26 27 28 29 30 31 32	9 10

(B) Indicates a 2 + 6 base board which also contains the processor circuits.

(E) Indicates an extension board.

Power Unit Output

If a power unit fault is suspected, carry out the following procedure:

- 1) Check illuminated mains switch is ON
- 2) Check that each voltage output, conforms to the label on the power supply unit, using a meter multi range.
- 3) If any of the voltages are missing, check each fuse.
- 4) Check the terminations to the output connector are not loose.
- 5) If the fault still exists, replace the complete power unit.

Terminal Faulting

If a fault is suspected at an extension, the terminal should be changed and the extension retested.

If the replacement terminal works, then replace the suspect terminal and:

- 1) Change first the line cord, then the handset cord and finally the handset.
At each stage the terminal should be retested to see if the fault is clear.
- 2) The terminal should be changed if the replacement of the above items does not clear the fault.

If the replacement terminal did not clear the fault, then testing from the CCU should take place:

- 3) Insert a terminal in the line jack associated with the Box connection test cord.
- 4) Insert the Box connection test cord, into the strips connection of the suspected extension.
- 5) Lift the handset then replace it in order to re initialise the extension. After a delay of 30secs the system will include this extension.

If the terminal now works, the cabling should be checked and if necessary, replaced.

If the terminal does not work,

- 6) Insert the Box connection test cord, into the strips connection of a working extension. Before doing so check that the extension is not busy.

If the terminal works when plugged into the strips connection of a working terminal, then the slide in card or connectors is suspected.

- 7) Replace the Box connection test cord in the strips connection of the faulty extension.
- 8) Swap the connectors on the PCB, so that the terminal is connected to a different PCB circuit.

If the fault is cleared the slide in card is faulty and should be replaced. If the fault is still not cleared, then the connection from the strips connection to the PCB should be checked.

Printer Error Messages

Whilst a printer is normally used for call logging, error messages are generated to assist maintenance staff.

The error message is given in the following format

```
***** ERROR XX PORT NN E 00
***** ERROR XX PORT NN T 00
```

Where XX = Error number

NN = Line circuit number

E 00 = Extension

T 00 = or Trunk

Error number	Action required
01	Software error, re-initialise system
02	Software error, re-initialise system
03	Software error, re-initialise system
04	Software error, re-initialise system
05	Terminal error, test terminal at CCU
06	Terminal error, test terminal at CCU
07	Trunk error, check slide in card
08	Trunk error, check slide in card
09	Trunk error, check slide in card
10	Conference error, change baseboard
11	Conference error, change baseboard
12	Tone error, change baseboard
13	Extension missing, check terminal or wiring
14	Software error, system automatically re-initialised
15	Software error, Full initialisation required

If the system has the mains disconnected the following message is given when the power is restored.

FULL SYSTEM RESET If the programming switch was ON (UP).

PARTIAL SYSTEM RESET If the programming switch was OFF (DOWN).

SYSTEM FAULTS

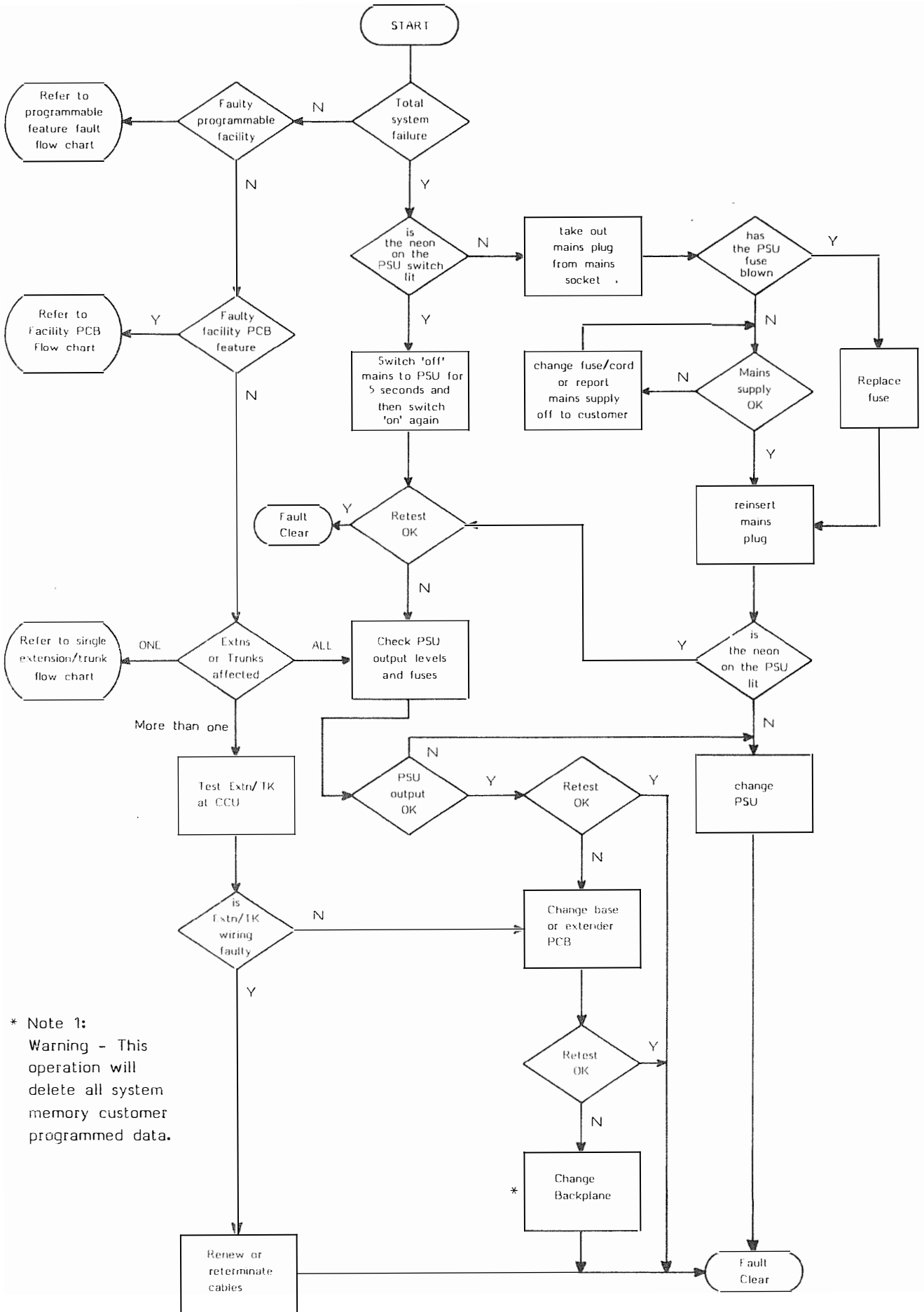

SINGLE EXTENSION/TRUNK FAULTS

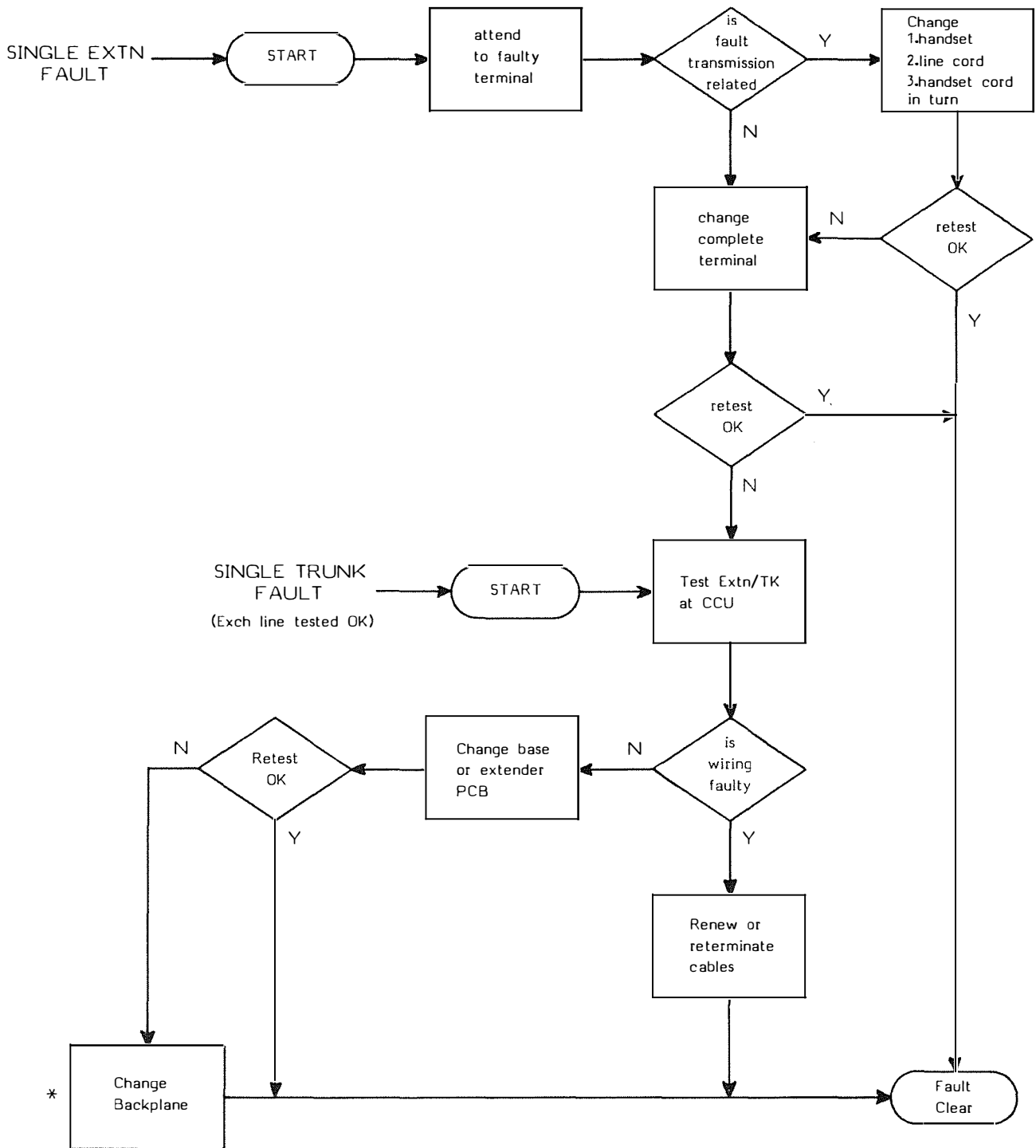

* Warning - This operation will delete all system memory customer programmed data.

PROGRAMMABLE FEATURE FAULTS

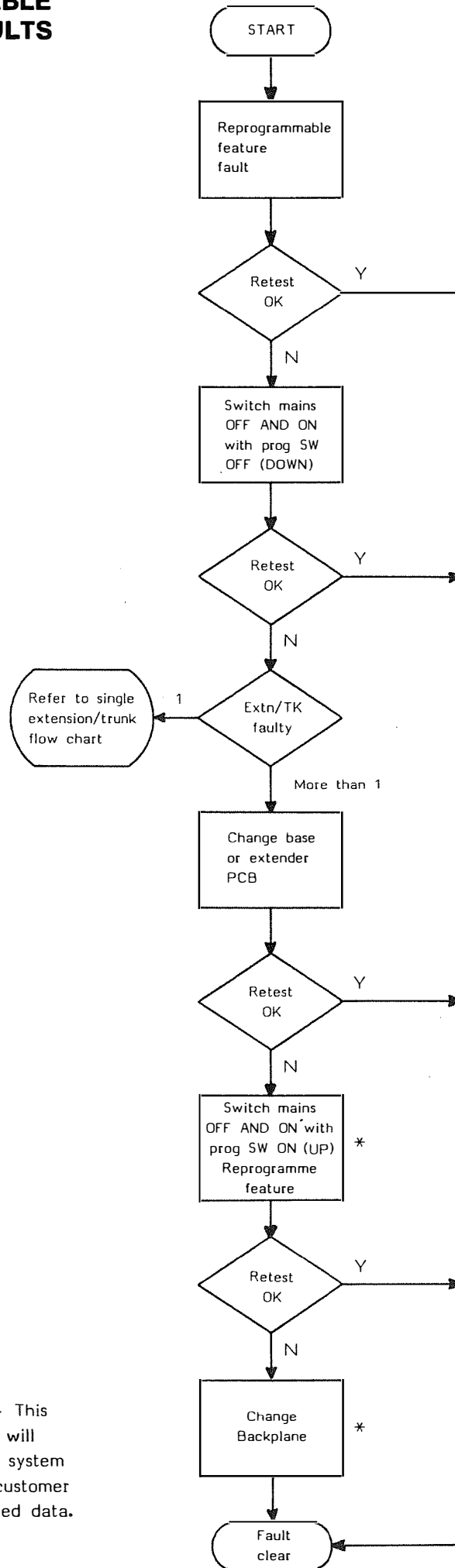

* Note 1:
Warning - This operation will delete all system memory customer programmed data.

FACILITIES PCB FAULTS

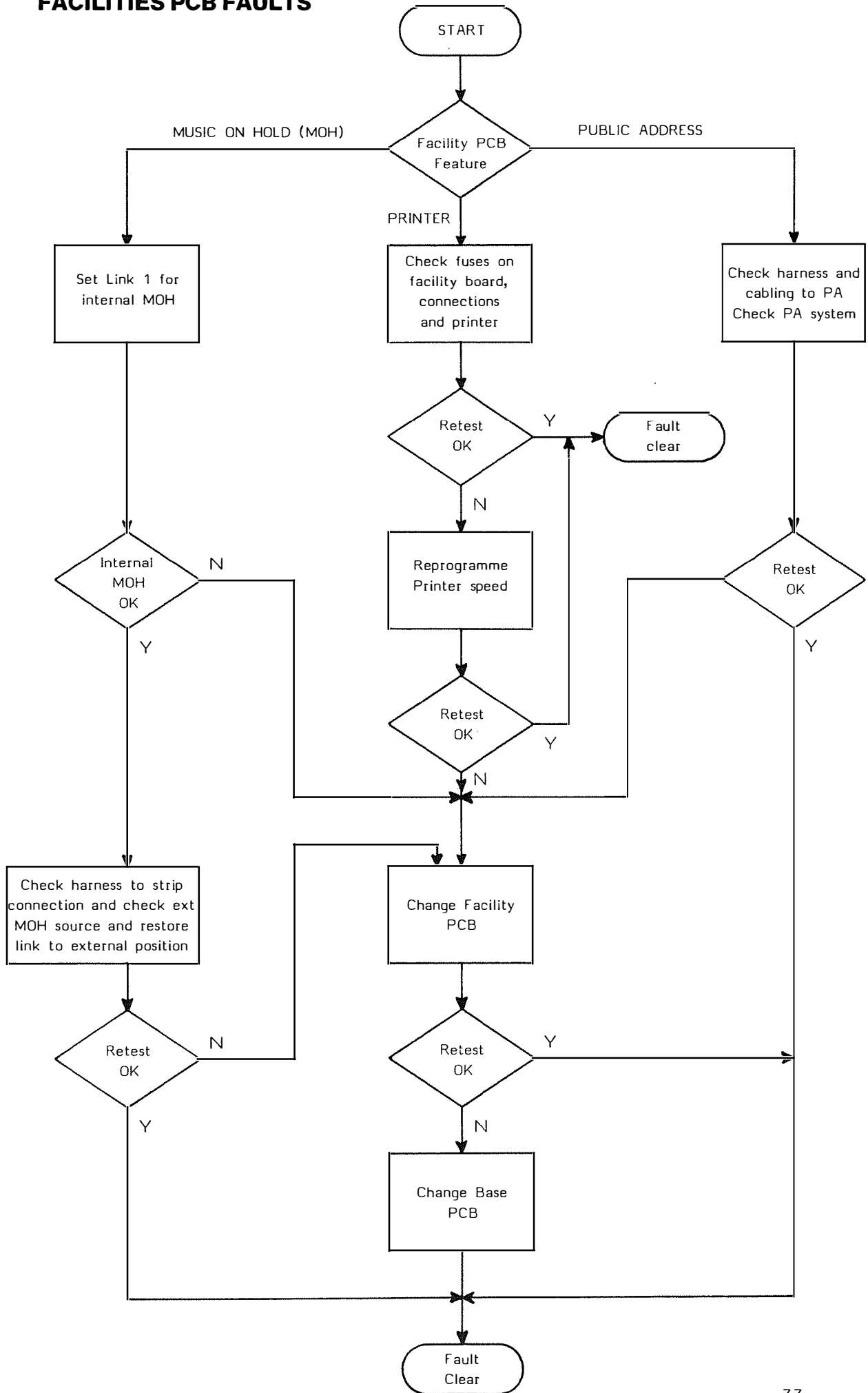

REPLACEMENT ITEMS

The following replacement items are available from Area Section Stocks.

RATE BOOK DESCRIPTION	ITEM CODE NO.
Merlin S2031 2 + 6 Extender Board 1A	37 4995 *
Merlin S2031 2 + 8 Extender Board 1A	37 4996 *
Merlin S2031 Facility Board 1A	37 4998 *
Merlin S2031 Power Supply Unit 1A	37 4999
Merlin S2031 2 + 6 Base Board 1A	37 5001 *
Merlin S2031 Backplane 1A	37 5002 *
Featurephone TX23	37 5004 *
Featurephone TX25	37 5005
Featurephone TX21	37 5008 *
Merlin S2031 Handset No.1A (Handset for TX23/25)	37 5013 *
Merlin S2031 Handset No.2A (Handset & cord for TX21)	37 5014 *
Cord Connecting 4/525 (Linecord for TX23/25)	37 5015 *
Cord Connecting 4/526 (Linecord for TX21)	37 5016 *
Cord Connecting 4/527 (Handset Cord for TX23/25)	37 5017 *

Fuses

	Beswick Fuse Type
Power unit input 5A time delay (20 X 5mm)	S504/5A *
Power unit output 10A fast acting (20 X 5mm)	TDC429/10A *
Facility Board 32mA fast acting (20 X 5mm)	S500/32mA *

These fuses may be obtained from AERCO Ltd; Kingsway House, 12 North Parade, Horsham, RH12 2DB. Telephone 0403 60206

It is recommended that Areas/Districts hold a set of spares (starred above - '*') in the form of a maintenance kit. This to be taken to site on all service visits to reduce out of service times.

A carrying case is available from Topper Cases Limited, St Peters Hill, Huntingdon, PE18 7ET. Telephone 0480 57251 and is coded G25 - Order Code 1599.

Connectors

PCB connectors are held for the two and four way wiring harness, by LCS/BSSU. These can be terminated by using Spanners Quickgrip No.1.

Power Unit Replacement Procedure

STATIC PRECAUTIONS MUST BE TAKEN

Power Unit (weight 8.5 kgs)

The power unit is removed from the main unit as follows:

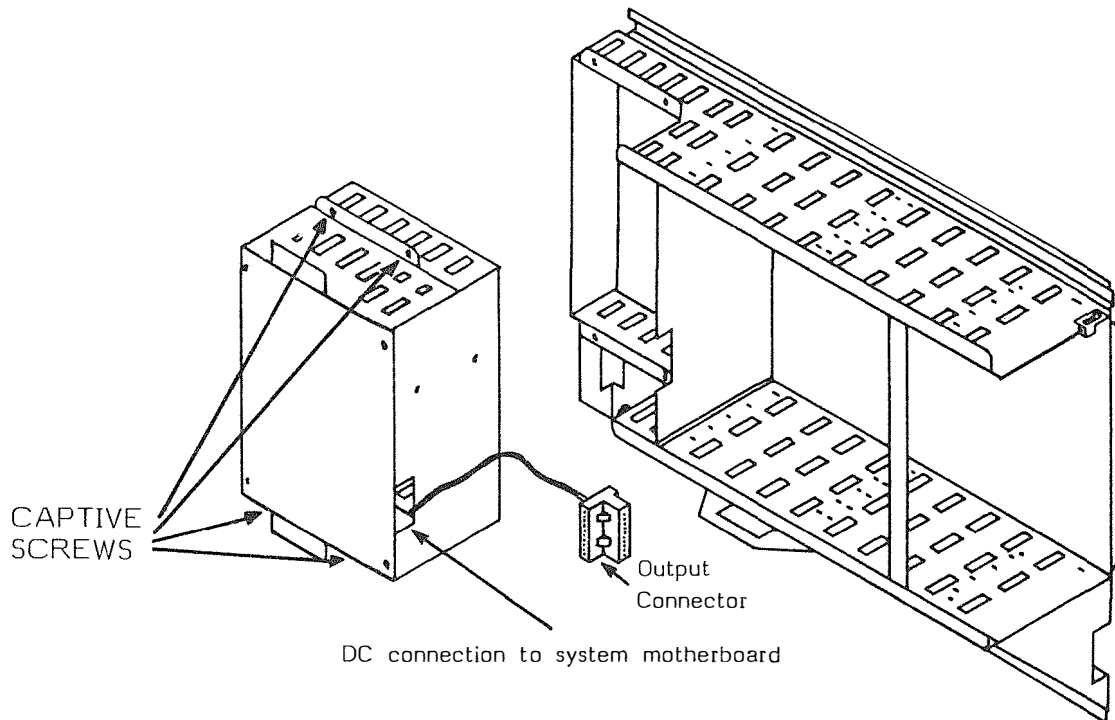

- 1) Ensure that the programming switch on the 2+6 baseboard is in the OFF position (down), to retain memory.
- 2) Switch off the mains supply, and remove both the 13amp plug from the mains supply socket, and the plug from the CCU.
- 3) Unscrew the four retaining screws that attach the power unit to the main chassis.
- 4) Move the power unit forward and 50mm to the left to gain access to the output connector.
- 5) Unplug the output connector.
- 6) Remove the power unit.
- 7) Check that the terminations to the output connector are not loose.

The replacement procedure is the reverse of the above.

Extender Boards Replacement Procedure

STATIC PRECAUTIONS MUST BE TAKEN

- 1) Ensure that the programming switch on the baseboard is in the OFF position (down).
- 2) Switch off and disconnect the mains supply.
- 3) Remove wiring connectors from board.
- 4) Withdraw the slide in unit sufficiently to clear the backplane.
- 5) Remove the earth protection connection.
- 6) Remove card.

Reconfigure the switches on the replacement unit to the original settings.

Fitting of a replacement unit is the reverse of the above procedure. After checking that the pins of the slide in card connector are not bent.

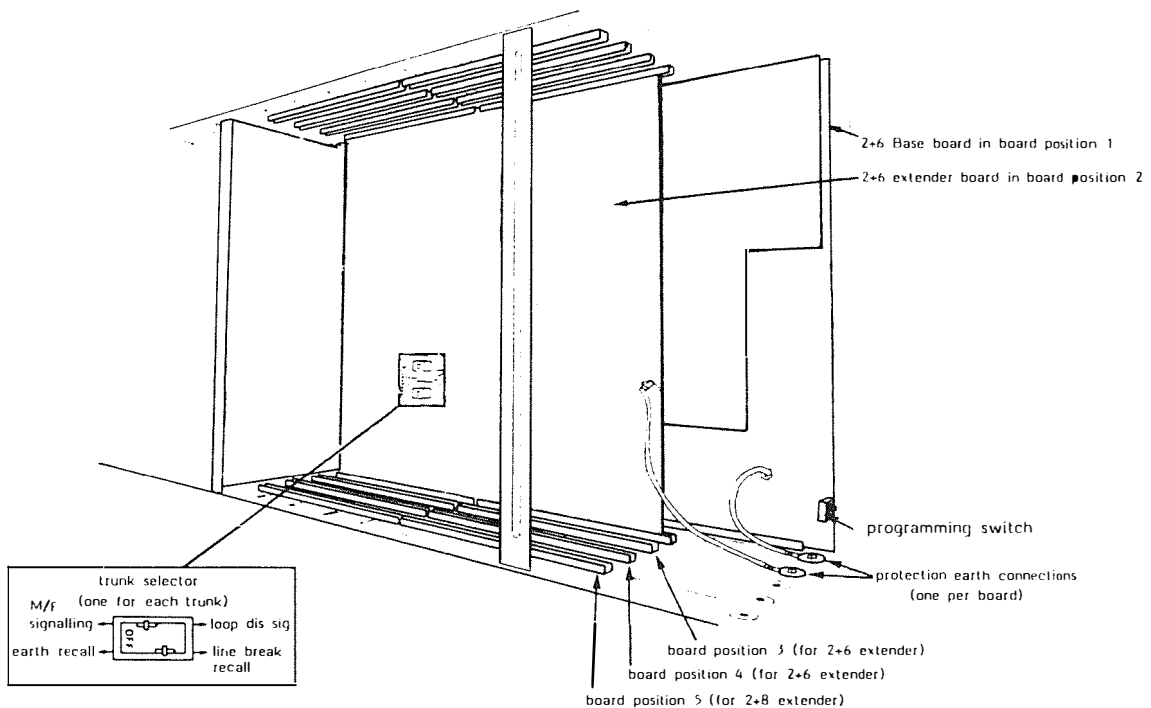

Baseboard and Facilities Board Replacement Procedure

STATIC PRECAUTIONS MUST BE TAKEN

- 1) Ensure that the programming switch on the baseboard is in the OFF position (down).
- 2) Switch off and disconnect the mains supply.
- 3) Remove the connectors from the baseboard and facilities board.
- 4) Unscrew the facilities board locking plate.
- 5) Withdraw the baseboard sufficiently to disengage the backplane, and remove the earth protection connections.
- 6) Remove both boards.
- 7) Carefully separate the facilities board from the baseboard.

Replace the base or facilities board, and ensure that if a new baseboard is fitted, the programming switch is in the OFF (down) position.

Music on hold and printer links must be set, if it is the facilities board that is changed.

Trunk selector switches must be set, if it is the baseboard that is changed.

Fitting of a replacement board is the reverse of the above procedure. It is important that the connectors on the facilities board are pushed carefully but firmly onto the baseboard. Check that connector pins are not bent.

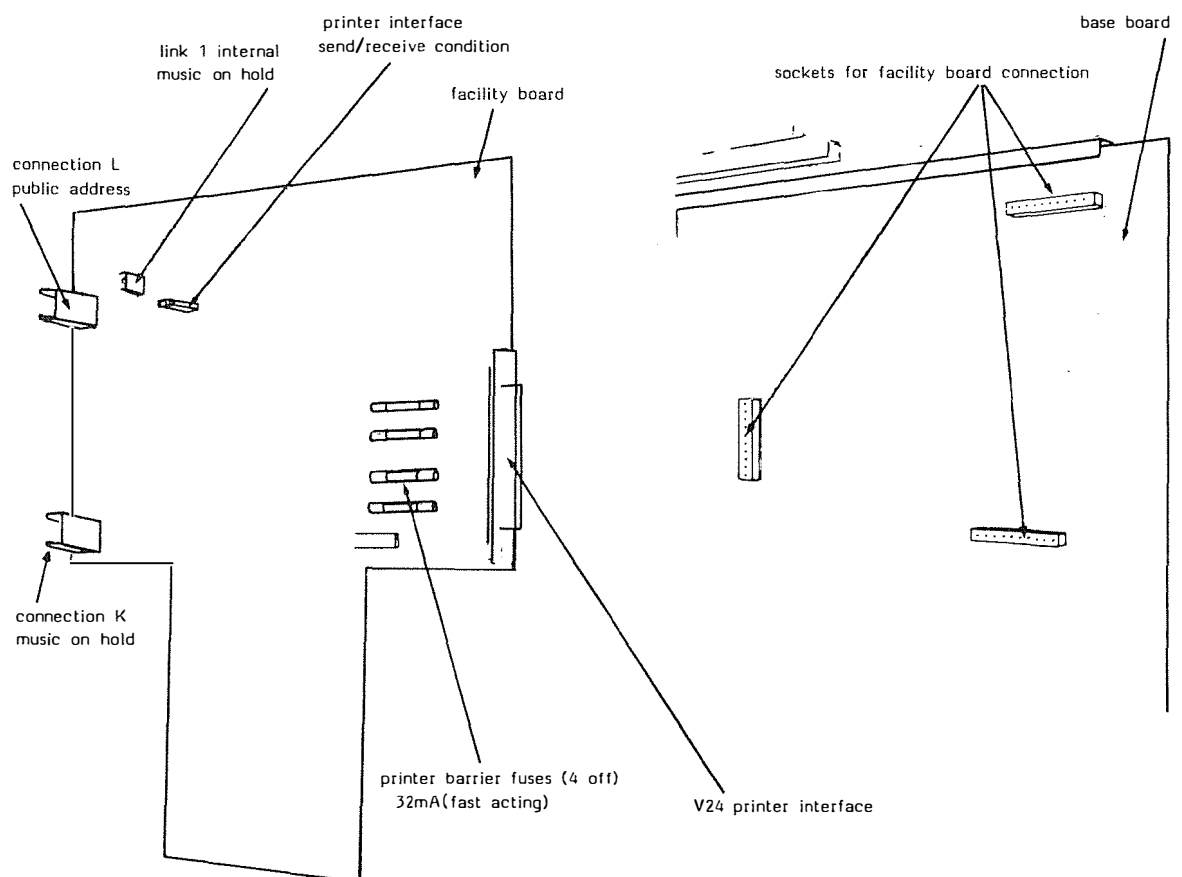

Backplane Replacement Procedure

STATIC PRECAUTIONS MUST BE TAKEN

The backplane replacement procedure is carried out after removal of baseboard and all extender boards, following the correct replacement procedures.

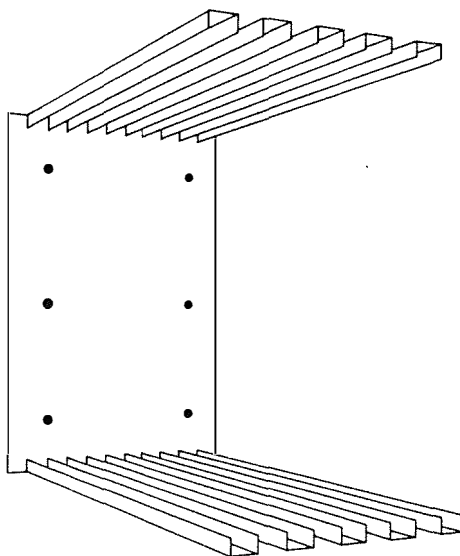

Remove the 6 retaining screws which hold the backplane to the main chassis.

Disconnect the power unit output connector and remove backplane. As a nickel-cadmium battery is part of the baseboard, care should be taken to avoid short circuiting the terminals.

The replacement is the reverse of the above procedure.

However it is recommended that before the screws are tightened, slide in cards should be inserted to check alignment of connectors.

Note: The system will now require full 'initialisation' as customers configuration is lost.

Terminals

Terminals are connected to line jack units via plug ended cords. The line cords for the TX23 and TX25 are identical, with the TX21 being separately coded.

Handsets and separate plug ended handset cords are available for the TX23/25. The TX21 handset comes fitted with a cord which is single plug ended.

If a terminal is replaced into a Line Jack Unit, the handset should be lifted then replaced. After a maximum delay of 30 secs the system will re initialise this extension.

FACILITIES

General







When the system is initialised, most facilities can be accessed by means of single key operations.

The TX21 terminal has reduced facilities and requires the 'F' key to be pressed prior to, EACH pressing of function keys.

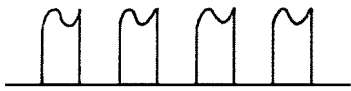
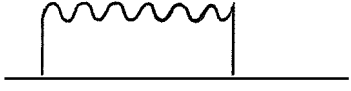
Facilities listed in this section are available on initialisation and are termed, Class Of Service '0' facilities.

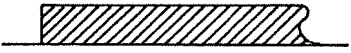
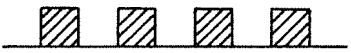
Other classes of service are dealt with in section xxx.

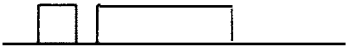
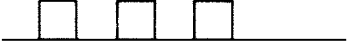
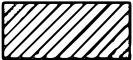
Tones

External-call tone (<i>'Ring'</i> tone & <i>'Ringin'</i>)		0.4s on/0.2s off/0.4s on/2.0s off - repeated
Internal-call tone (<i>'Ring'</i> tone & <i>'Ringin'</i>)		0.4s on/0.8s off - repeated
Recall		2.0s on - single pulse
Handsfree call (Splash)		0.8s on - single pulse
Dial or <i>'success'</i> tone		Continuous
Busy tone		0.36s on/0.36s off repeated
Facility unavailable/ Number unobtainable tone		Continuous
Conference tone		0.2s on/0.1s off/0.7s on - on connection to conference
Intrusion tone		0.2s on/0.2s off/0.2s on/0.2s off/0.2s on - at start and end of intrusion
Low note:	 500Hz	
High note:	 1000Hz	
High-low note:	 0.08s, 500Hz/0.02s, 1000Hz - repeated	

Tone volume control is provided by setting a switch on the underside of the TX23/25 to Loud Med or Soft. TX21 terminals have a variable volume control also fitted underneath.

Access to Outside Lines

Lift the handset and internal dial tone is heard.
Press 9 - exchange line dial tone is heard when the system seizes the first free outside line.
Proceed to dial the required number.

Using the TX23/25, access may also be gained by pressing the trunk key associated with a free outside line.

Lamp Indication on TX23/25

When the handset is lifted, the RED LED for that extension will glow.

When a trunk is seized, the GREEN LED for that trunk will glow. A RED LED will glow at all other featurephones to indicate a busy trunk.

External Incoming Call

All terminals will ring when an external call is received by the system. Ringing takes the familiar form of two short bursts then a pause.

To answer the call - lift the handset.

Lamp Indication on TX23/25

The RED LED associated with the external trunk flashes. This stops when the handset is lifted to answer the call. The GREEN LED for that trunk now glows, with RED LED'S glowing at other featurephones to indicate the busy trunk.

PBX Calls

If access to PBX lines is provided, this can be obtained by pressing the trunk key associated with the required PBX line.

If the system has been programmed to accept individual PBX lines, then these may be accessed by dialling '7' followed by the number of the PBX line. eg If trunk 4 is a PBX line this is accessed by dialling '7' then '4'.

If the system has been programmed to accept a group of PBX lines, then the first free line is accessed by dialling '7'.

Tone and LED indication is the same as Outside Line calls.

Making an Internal Call

Internal calls are made by lifting the handset and dialling the required extension number.

All extensions are numbered sequentially from 201 to 232. For example; extension 6 is given the number 206.

The TX23/25 may also make an internal call, by lifting the handset and pressing the extension key associated with the required extension. If however the required extension is between 17 and 32, then the 'SHIFT' key is first pressed. This changes the designation of 1 to 16 extension keys, to 17 to 32. Access to extensions 17 to 32 may only be accessed by this method, within 5 seconds of pressing 'SHIFT'.

Lamp Indication on TX23/25

When the handset is lifted, the RED LED associated with the extension glows.

When ringing an extension, the RED LED of the calling extension flashes. This stops flashing and glows when answered.

A GREEN LED next to the 'SHIFT' key glows for 5 seconds, when the 'SHIFT' key is pressed.

Receiving an Internal Call

An internal call is identified by a single short burst of ringing followed by a pause. This sequence is then repeated.

An internal call is answered by lifting the handset.

Lamp Indication on TX23/25

The calling extension is identified by a flashing RED LED, which changes to RED LED glowing when the call is answered.

When the called extension lifts the handset to answer the call, its RED LED glows.

Abbreviated Dialling

This facility enables an external number to be stored then obtained by use of two digit codes (01-16) or extension keys 1 to 16.

Codes 01 to 16 are used as a personal store, by individual extensions, with storing of numbers carried out at each extension.

A system store is also available with codes 50 to 99 allocated. Number storage is carried out at the programming extension.

To store each number, lift the handset then press 'ABDIAL'. Then press the two digit code or extension key to which the number is to be allocated.

Key the numbers required then press 'HOLD'.

If a pause between digits is required (ie for PBX working) this may be introduced by pressing 'ABDIAL' instead of a digit. 'RECALL', '*' and '#' may also be introduced in place of digits, if required.

Using Abbreviated Dialling

To use this facility, gain access to a trunk in the normal manner. Press 'ABDIAL', then dial the two digit code or press the extension key to which the number is allocated.

Cancelling Codes

To remove a number from a personal store, lift the handset and press 'ABDIAL'.

Then press the two digit code or press the allocated extension key of the number to be erased, followed by 'CANCEL'.

This particular code or extension key store, is now spare.

Redial

This facility enables automatic redialling of the last number dialled by an extension.

To use this facility, gain access to an outside line in the normal manner, then press 'REDIAL' and wait for the call to be established.

Hold

This facility allows temporary withdrawal from a call, without releasing the connection.

If Music on Hold is provided, this is given to held calls. It is not possible to hold calls to a telephone/receptionist extension.

To hold calls, press the 'HOLD' key. Dial tone is heard and a further call may be made. If the 'HOLD' key is pressed during this call, the second call is held and the previously held call reconnected.

To return to the call held, press the 'HOLD' key. This allows calls to be swapped between by pressing the 'HOLD' key.

Enquiry calls may be made when an internal call is held, by dialling or pressing the required extension number. This automatically places the call into hold.

To return to the held call (after an enquiry call), press 'CANCEL', this causes re-connection to the previous held call.

Release of Hold

Any held call is automatically released when the handset is replaced.

If a call is accidentally left in hold when the handset is replaced, the holding extension will ring automatically after 30 seconds. The held call is connected when the handset is lifted.

System Hold

The TX23/25 may hold external calls in a common store, which can be accessed by any featurephone.

To use this facility, press the external line key of the call to be held.

The GREEN LED of the held trunk flashes at all featurephones. Dial tone is heard and a further call may be made.

A page call (see 'PAGE' facility) could be made at this stage, to inform a third party that a call is held on a particular trunk.

Access to the held trunk is gained by pressing the external line key after lifting the handset.

If an enquiry call is made to another extension, this extension may be connected to the held call. To connect the call, the enquiry caller replaces the handset. The extension accepting the call then presses the held trunk key.

Enquiry

An enquiry call may be made by asking the caller to hold, then pressing the 'HOLD' key. Dial tone is heard and the enquiry call can be made, by dialling the required number. If the call is then to be transferred, replace the handset, or press 'TRANS' if a further call is to be made.

If the call in progress is an internal call, an enquiry call may be made by pressing the number of the required extension. The established call is automatically placed on hold.

To return to the held call, press 'CANCEL'.

Transfer

The transfer facility is used to pass a call to another extension (or trunk).

If the call received is to be transferred, ask the calling party to hold, then make an enquiry call.

If the enquiry point will accept the call, replace the handset, or press 'TRANS' if another call is to be made.

Conference

Conference permits the connection of up to 6 parties to a call at the same time.

The 6 parties may be 2 groups of 3, or 1 group of up to 6. Each group may include 1 external trunk.

To include other parties into a telephone call, ask the existing call to hold. Make an enquiry call to the next party required in conference. After the call has been answered connect the conference by pressing 'CONF'.

Further parties may be added after making enquiry calls.

To temporarily withdraw from conference, press 'HOLD' or make an enquiry call.

To return to conference press 'CANCEL'.

To leave the conference replace the handset, or press 'CLEAR' if another call is to be made.

Divert

The divert facility enables all calls to an extension, to be diverted to another extension.

The extension that has the calls diverted to it, cannot then redirect calls to other extensions.

Diverting Calls

To divert calls to other extensions, press 'DIVERT' then press the number of the extension to which calls are to be diverted to.

Internal dial tone is heard and further calls may now be made.

On the TX23/25 a GREEN LED GLOWING indication is given above the 'DIVERT' key, with a RED LED GLOWING indication given above the 'DIVERT' key at the diverted to extension.

Cancelling Divert

To cancel divert, lift the handset and press 'DIVERT' then press 'CANCEL'.

Changing Divert at Diverted to Extension

To change to a new diverted to extension, at the existing diverted to extension.

Lift the handset, press 'DIVERT' then press the number of the extension FROM which calls were diverted. Then press the number of the new extension to which calls are to be diverted TO.

Cancelling at Diverting to Extension

To cancel call divert at the diverted to extension.

Press 'DIVERT' then press the number of the diverted FROM extension twice.

Call Redirect

A diversion facility is available which automatically redirects calls to another extension, if the called extension is busy, or if no reply after 10 seconds.

To redirect calls, lift the handset and press 'DIVERT' twice. Then press the number of the extension to which calls are to be diverted to.

Internal dial tone is now heard and further calls may be made.

On the TX23/25 a GREEN LED GLOWING indication is given above the 'DIVERT' key, with a RED LED GLOWING indication given above the 'DIVERT' key at the diverted to extension.

Using the TX21 the 'F' key must be pressed prior to EACH pressing of a function key.

Cancelling Redirect

To cancel redirect, lift the handset and press 'DIVERT' twice, then press 'CANCEL'.

Pickup

This facility enables unanswered internal calls, to be answered from an extension other than the one called. This would normally be used only when extensions were near each other.

To answer a call to another extension, lift the handset and press the number of the called extension. Busy tone is now heard. Press 'PICKUP' and the call is now connected.

Answer Page

This facility enables a paged message to be answered by any telephone.

To connect to the calling pager, lift the handset and press 'ANS'.

If several page messages are in progress, it may be necessary to press 'ANS' several times.

This connects the answering extension to each 'pager' in turn.

Camp

The camp facility enables you to either reserve a call to a busy extension or to give an indication at an unanswered extension, in order to establish a call.

The camp facility may also be used in order to wait for a free trunk.

Camp on Busy

If the called extension is busy, press the 'CAMP' key. A GREEN LED on featurephones glows, and dial tone is heard. Further calls may now be made.

At the called extension a RED FLASHING LED is given, if a featurephone.

When both parties are free, a 2 second recall signal is given to the calling extension.

This must be answered within 15 seconds for an extension or, 5 seconds for a trunk.

When the caller lifts the handset the called extension will start to ring normally.

The call is answered in the normal manner.

Cancelling Camp On

To cancel camp on, press 'CAMP' then press 'CANCEL'.

Camp on Unanswered

A TX21 cannot be camped onto when unanswered, as no LED indication of the camp can be given. Therefore a facility unobtainable tone is given.

If a called extension does not answer, press 'CAMP'.

The GREEN LED on featurephones glows and dial tone is heard. Further calls may now be made.

At the called extension a RED LED glows to inform the called party that another extension is camped on.

The called party establishes the connection by pressing 'CAMP'. Busy tone may be heard if the calling party is now busy.

Cancelling Camp On

Cancelling camp on is carried out by pressing 'CAMP'; then 'CANCEL'.

FEATUREPHONE FACILITIES

Shift

The shift key is used on featurephones, to change the key designation of extensions 1 - 16 to 17 - 32, and is effective for 5 seconds. Details of operation are given under Making an Internal Call.

Page

The page facility is used to broadcast messages to all free featurephones. This message can also be broadcast over a public address system if fitted.

To use this facility, lift the handset and press 'PAGE'. Messages may now be transmitted to all free featurephones, provided the page key is held. The page key, which must not be pressed for more than 30 seconds, should be released after the message has been broadcast.

If a reply to the page message is required, the handset should not be replaced.

If the extension answering the page is not the required one, press 'CANCEL' to remain in the awaiting page reply state.

If the 'page call' was an enquiry call, the held call is transferred when the handset is replaced.

Intrude

The intrude facility allows an existing call to an extension to be interrupted, for up to 15 seconds in order to pass a message. A warning tone is given at the start and end of intrusion.

If a call to an extension results in busy tone, press and hold the 'INTR' key. After the warning tone, the called extension is connected to the intruding extension for 15 seconds. The third party cannot speak to or hear the intruder, but can still hear the intruded upon extension. When the 'INTR' key is released, or at the end of the 15 seconds period, the warning tone is reapplied.

An intrusion to a called extension is released, if the caller replaces the handset within 6 seconds of intrusion.

Incoming trunk calls, conference calls, and Do Not Disturb calls cannot be intruded upon.

Do Not Disturb

This prevents calls from ringing the extension.

Press 'DND', a GREEN GLOWING LED indication is given, above the DND key.

To cancel DND, press 'DND'.

TX23 Features

Using the TX23, calls may be originated without lifting the handset. The loudspeaker being used to monitor the call.

To use this facility, press the 'H/FREE' key. Dial tone is heard, and a call can be made without lifting the handset. To speak the handset must be removed, this disconnects the loudspeaker monitor.

Monitor mode may be returned to at any stage, by pressing 'H/FREE', then replacing the handset.

TX25 Features

The TX25 has the capability of full loudspeaking and also automatic answer, if required.

When using the loudspeaker mode, calls can be made or received without lifting the handset.

To use the loudspeaker mode, press 'H/FREE'.

The GREEN LED above the mic key glows, and calls can now be made, or answered without lifting the handset. Calls are cleared by pressing 'CLEAR'.

To change from loudspeaking to normal mode, lift the handset. The loudspeaking mode may be reverted to at any stage, by pressing the H/FREE key and replacing the handset.

A microphone mute facility is available, which temporarily switches the microphone off without affecting the loudspeaker.

To use this facility, press 'MIC'. To return to full loudspeaking mode, press 'MIC' once more.

Whilst the microphone mute is in use, a GREEN LED FLASHING indication is given above the mic key.

Auto Answer

A facility is available, which allows automatic answer of internal calls, with a 0.8sec warning tone given.

To use this facility press 'AUTO', the GREEN LED above the auto key now glows.

Normal mode is returned to by pressing 'AUTO', which now causes the GREEN LED to be extinguished.

ADDITIONAL FACILITIES

Manager/Secretary

A facility is available which allows featurephone extensions to be grouped as pairs (manager/secretary). This enables calls to the managers extension to be redirected to the secretaries extension if:

- 1) The managers extension is busy
- 2) If no reply is received after 10 seconds.

The Do Not Disturb key (DND), gives this facility with indications given as follows:

Managers featurephone DND LED

RED LED GLOWING = secretary absent (DND pressed) or busy

GREEN LED GLOWING = diversion in operation

GREEN LED FLASHING = a call is being diverted

GREEN LED FAST FLASHING = a diverted call unanswered or the secretary is absent.

Secretarys Featurephone DND LED

RED LED GLOWING = diversion in operation or manager busy

RED LED FLASHING = a diverted call is being received

GREEN LED GLOWING = secretary absent (DND pressed)

A 'BUZZ' key allows either party to attract the others attention, even when a call is in progress.

Diverting Calls to the Secretary

To divert calls to the secretary, press 'DND'.

A GREEN LED indication is given at the managers featurephone, and a RED LED at the secretarys featurephone. The Do Not Disturb is cancelled by pressing 'DND' again, which extinguishes the LED.

Secretary Absent

When the secretary leaves the office, the 'DND' key should be pressed at the secretarys featurephone. A GREEN LED indication is given, with a RED LED at the managers featurephone. This is cancelled by pressing 'DND' again, which extinguishes the LED.

Attract Attention

To attract the attention of the manager/secretary press 'BUZZ'.

Up to nine manager/secretary pairs may be stored in the system, however an extension may not belong to more than one group.

Pick Up Groups

A facility is available to program extensions into pick-up groups. Each member of the group is able to answer calls to other members, without pressing the extension key.

A maximum of nine pick-up groups are possible, with each extension only allowed to belong to one group.

Note: The class of service given to an extension must allow pick up.

To answer a call to another group member, press 'PICK-UP'.

Telephone Receptionist

Any featurephone may be allocated as the telephone/receptionist terminal, in order to answer calls and then transfer these calls to other extensions.

Extensions with call-barring, may obtain barred numbers via the telephone/receptionist.

Extensions gain access to the telephone/receptionist by dialling '0'. If the telephone/receptionist is engaged, calling extensions will still ring and not be given engaged tone.

The telephone/receptionist is able to transfer external calls to other extensions, without waiting for the called extension to answer. External calls are transferred by, answering the call at the telephone/receptionist, then pressing the required extension number. Pressing 'TRANS' will complete the transaction.

The telephone/receptionist is now free to make further calls.

Night Service

A facility is available which allows all incoming calls to be directed to set extensions when Night Service is invoked. This facility is operated by the extension or extensions, given the night service class of service.

To switch the system into Night Service, press 'ANS'. The RED and GREEN DND LED's FLASH. Press the extension keys until a RED LED GLOWING indication is given for the required extensions. To store this information and initiate Night Service, press 'HOLD'.

The RED DND LED FLASHES at all featurephones when night service is in operation.

PROGRAMMING

General

Most facilities are available to all extensions when the system is first initialised. Individual customers configuration is available by programming.

Program Extension

Extension number 1 is the designated extension from which programming is initially carried out.

Initial Programming

- 1) Switch the mains supply OFF.
- 2) Place the programming switch in the ON position (UP).
- 3) Switch the mains supply ON.
- 4) At extension number 1, press 'H/FREE' then '*'.

Both LED's above the camp key now flash and internal dial tone is heard. Extension number 1 is now in programming mode, and will not function as a normal extension.

The programming switch MUST now be placed in the OFF position (DOWN) IMMEDIATELY. A mains failure with the switch in the UP position would clear any customers programmed data.

Changing Programming Extension

Although extension number 1 is initially used as the programming extension, it is possible to change to another featurephone.

To change the programmed extension, place the programming switch in the ON position (UP).

On the existing programming extension press 'H/FREE' then '*', the LED's above the camp key now flash.

The programming switch must be now placed in the OFF position (DOWN).

Press 'TRANS', then press the extension key of the featurephone to which programming is to be extended. Press '*' and then press 'HOLD'. The LED's above the camp key will stop flashing, as the programming extension has now been changed.

Subsequent Programming

To amend or return to programming, do not switch the mains supply off.

To program from the designated extension, place the programming switch in the ON position (UP). Press 'H/FREE' then '*'. Immediately restore the programming switch.

Locating Programming Extension

If the programming extension has been changed and a record is not available.

Place the programming switch in the ON position (UP), and at each featurephone in turn, press 'H/FREE' then '*'. The programming extension is the extension which displays flashing LED's above the camp key.

Exit Programming

To return to normal mode after programming, press 'CLEAR'.

The following facilities can be changed by programming at the designated programming extension, whilst in the programming mode.

Outside Lines

A maximum of 10 outside lines may be accessed by the system, these may be exchange lines, PBX circuits or a combination of the two. Each extension can be programmed to allow incoming access from each trunk as follows -

- 1) Full access, Incoming calls ring and a flashing RED LED indication given on featurephones.
- 2) Partial access, Incoming calls give a RED LED flashing indication, with no ringing. This must not be given to the TX21 as no LED indication is given.
- 3) No access, Incoming calls access not allowed.

Each extension can be programmed to allow or bar outgoing access to each trunk.

Press the extension key of the first extension to be programmed. The LED's next to the trunk keys indicate the access allowed. This may be changed by pressing each trunk key until the LED indication is correct, then allocating this access to the extension. The chart below shows the levels of access obtainable by pressing a trunk key six times.

Full incoming and outgoing access.	RED LED GLOWS	GREEN LED GLOWS
Outgoing access only.		GREEN LED GLOWS
Incoming flash only No outgoing access	RED LED FLASHING	
Full incoming No outgoing access	RED LED GLOWS	
No incoming or outgoing access		
Full outgoing access Incoming flash only	RED LED FLASHING	GREEN LED GLOWS

To allocate this access pattern to extensions, press the extension key of each extension.

The 'HOLD' should now be pressed to store this information.

The above procedure should be repeated until each extension has the desired trunk access.

ANY TRUNKS THAT HAVE BEEN EQUIPPED BUT WILL NOT BE USED MUST HAVE ACCESS BARRED BY PROGRAMMING.

PBX Access

Any of the trunks (1 to 10), may be used as PBX lines provided the system has to be programmed to recognise each PBX trunk.

Single Line PBX Access

To program the system, press 'REDIAL', then press the trunk key of each trunk requiring PBX access. A GREEN TRUNK LED will glow for each PBX trunk. To complete the transaction press 'HOLD'.

Each extension now has access to PBX trunks, by lifting the handset and pressing '7', followed by the trunk number. eg If trunk 6 is a PBX line, this is obtained by dialling '7' then '6'.

Multiple Line PBX Access

If several trunks are connected to a PBX, the system can be programmed to 'hunt' over busy lines.

Programming is carried out after each PBX trunk has been programmed as above.

To program the system, press 'CONF', then press dialling key '2', then 'HOLD'.

Each extension now has access to PBX trunks by dialling '7'.

PBX Recall

If the PBX has recall facilities, this has to be programmed.

To program the system, press 'RECALL', then the trunk keys to which the recall is to be given. A GREEN LED indication is given for each PBX trunk. To complete the transaction press 'HOLD'.

Call Barring

Access to outside lines may be restricted to prevent extensions from making certain types of calls.

- 1) International and Irish Republic calls are barred, with extensions only allowed to make STD or Local calls.
- 2) International, Irish Republic and STD calls are barred, with extensions only allowed to make Local calls.

Extensions with call barring are prevented from making Level '1' calls, as the operator could connect a call, which should be barred to an extension.

To program the system, press 'PAGE'. LED indication is now given for each extension, which may be changed by pressing the extension key until the desired LED indication is given.

No barring	NO LED INDICATION
International and STD calls barred	RED LED GLOWS
International calls barred	RED LED FLASHES

When the correct LED indication is given for each extension press 'HOLD'.

Call Barring Exceptions

The system may be programmed to allow exceptions to call barring. A store of up to 30 permitted numbers, each of which contains up to four digits is allowed. Discrimination takes place up to the fourth digit. eg 0601 codes may be allowed, with 0602 barred.

To program the system with call barring exceptions, press 'INTR' then using the dialling keys dial the index number of the permitted code (01 to 30), followed by the 4 digit permitted number, then 'HOLD'. Blanks (which the system will interpret as any digit), may be included within these four digits by using the 'BUZZ' key.

Repeat the sequence for all permitted codes.

To cancel a permitted code, press 'INTR' then dial the code to be removed, followed by 'HOLD'.

The list of permitted numbers should be entered by the customer on the System Managers Chart No 3.

List of Permitted Numbers

<i>index number</i>	permitted telephone numbers				notes	<i>index number</i>	permitted telephone numbers				notes
01	0	6	0	1	EXAMPLE	16					
02						17					
03						18					
04						19					
05						20					
06						21					
07						22					
08						23					
09						24					
10						25					
11						26					
12						27					
13						28					
14						29					
15						30					

System Managers Chart No.3

Classes of Service

Each extension is given a Class of Service, which is divided into:

- 1) What the extension is able to do, to other extensions (ACTIVE).
- 2) What other extensions are able to do, to the extension (PASSIVE).

When the system is switched on with the program switch in the ON position (UP), each extension is given the facilities offered by CLASS of service '0' (Default).

Class of service 1 to 3 are also set up within the system. These may be allocated to extensions whose requirements match one of these classes of service.

Class of Service '0'

(all facilities)
ALLOWS YOU TO (ACTIVE)

Intrude
Page
Do not disturb
Pick-up
Divert
Conference

Camp on extension
Camp on outside line
Abbreviated system dialling
Abbreviated personal dialling
Night service

ALLOWS OTHERS TO (PASSIVE)

Intrude
Page
Pick-up

Divert
Camp on extension

Class of Service '1'

(basic for most users)
ALLOWS YOU TO (ACTIVE)

Page
Pick-up
Divert
Conference

Camp on extension
Camp on outside line
Abbreviated system dialling
Abbreviated personal dialling

ALLOWS OTHERS TO (PASSIVE)

Intrude
Page
Pick-up

Divert
Camp on extension

Class of Service '2'

(Managers and senior executives)
ALLOWS YOU TO (ACTIVE)

Page
Do not disturb
Divert
Conference

Camp on extension
Camp on outside line
Abbreviated system dialling
Abbreviated personal dialling

ALLOWS OTHERS TO (PASSIVE)

Pick-up

Class of Service '3'

(Receptionist)
ALLOWS YOU TO (ACTIVE)

Intrude
Page
Pick-up
Conference
Camp on extension

Camp on outside line
Abbreviated system dialling
Abbreviated personal dialling
Night service

ALLOWS OTHERS TO (PASSIVE)

Divert

Altering an Existing or Creating a New Class of Service

If the facilities offered by the Classes of Service 0,1,2, or 3 do not exactly meet the requirements of an extension or group of extensions. Classes of Service 1,2 or 3 may be altered, or new Classes of Service numbered from 4 to 9 may be created.

System Managers Chart No 2 is used by the customer when deciding which active and passive facilities are required.

Facilities in Each Class of Service

class of service	intrude	page	do not disturb	pick-up	divert	conference	camp on extension	camp on outside line	abbreviated system dialling	abbreviated personal dialling	night service
key you press light at ext. no.	INTR 1	PAGE 2	DND 3	PICKUP 4	DIVERT 5	CONF 6	CAMP 7	CAMP 8	ABDIAL 9	ABDIAL 10	ANS 11
0 active	✓	✓	✓	✓	✓	✓	✓	✓	✓	✓	✓
0 passive	✓	✓		✓	✓		✓				
1 active		✓		✓	✓	✓	✓	✓	✓	✓	
1 passive	✓	✓		✓	✓		✓				
2 active		✓	✓		✓	✓	✓	✓	✓	✓	
2 passive				✓							
3 active	✓	✓		✓		✓	✓	✓	✓	✓	✓
3 passive					✓						
4 active											
4 passive											
5 active											
5 passive											
6 active											
6 passive											
7 active											
7 passive											
8 active											
8 passive											
9 active											
9 passive											

System Managers Chart No.2

Overlay Cards

To alter or change a Class of Service, the two overlays are required.

The ACTIVE overlay.

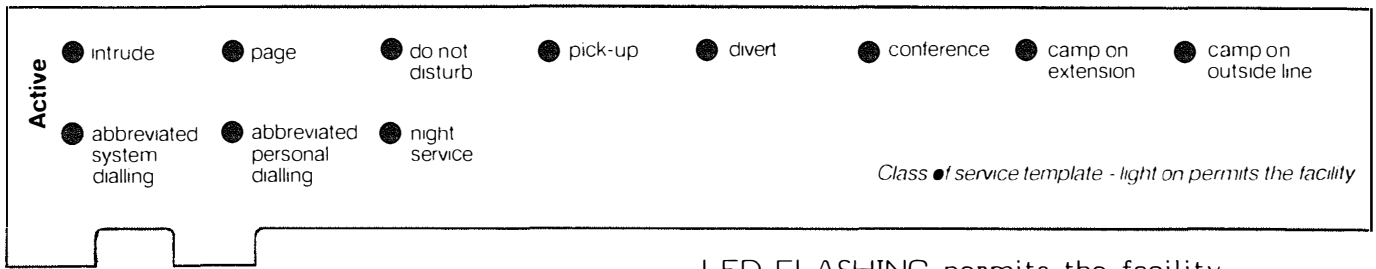

LED FLASHING permits the facility

Active

Place the ACTIVE overlay over the extension LED's and using the System Managers Chart No 2, press the dialling key (0 - 9) of the Class of Service. The LED's now flash to indicate which ACTIVE facilities are present for that particular Class of Service.

To set up or change the ACTIVE facilities press the facility key which is associated with each facility, until the correct sequence is set on the LED's. Press 'HOLD' to store the ACTIVE facilities for that Class of Service.

The PASSIVE overlay

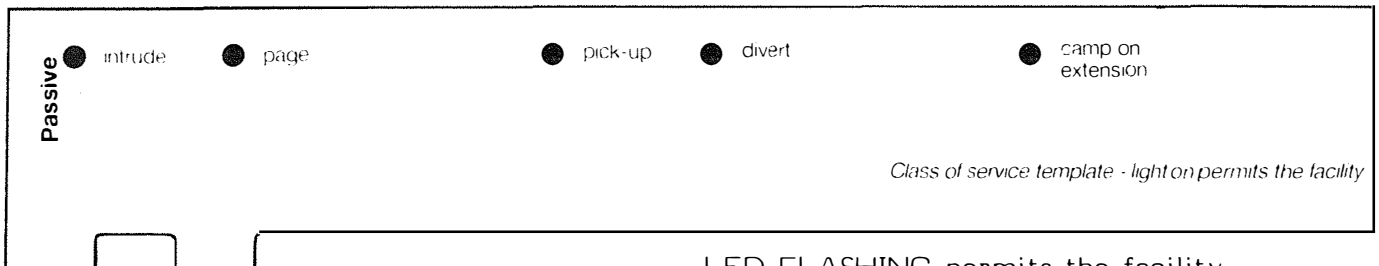

LED FLASHING permits the facility

Passive

Place the PASSIVE overlay over the extension LED's, and using the System Managers Chart No 2, press the dialling key (0 - 9) of the Class of Service, followed by '#'. The LED's now flash to indicate which PASSIVE facilities are present for that particular Class of Service.

To set up or change the PASSIVE facilities press the facility key associated with each facility, until the correct sequence is set on the LED's. Press 'HOLD' to store the PASSIVE facilities for that Class of Service.

Allocating Classes of Service to Extensions (Using the System Managers Chart No.1)

Press the dialling key (0 - 9) of the Class of Service, followed by *1

Press the extension keys of extensions requiring this Class of Service until a RED LED GLOWING indication shows. Press 'HOLD' to store these extensions against the Class of Service.

If an extension is not given a new Class of Service, the default Class of Service is '0'.

Manager/Secretary

To program the manager/secretary pair press 'DND'. The GREEN DND LED and both CAMP LED's FLASH.

Press the extension key of the proposed managers extension. The GREEN DND LED goes out, and the RED DND LED FLASHES.

Press the extension key of the proposed secretarys extension. The RED DND LED goes out. Press 'HOLD' to store the manager/secretary pair. If, when the extension key is pressed another extension LED flashes, the chosen extension is already in a manager/secretary pairing which would be deleted if programming was continued. Press 'CANCEL' to prevent this manager/secretary pairing.

To cancel the pair press 'TRANS', then the extension key of either the managers or the secretarys extension, then 'DND'. The RED and GREEN DND and CAMP LED's FLASH, and the RED LED's of the extensions FLASH. Press 'HOLD', and the pair is removed from the store.

Up to nine manager/secretary pairs may be stored in the system, however an extension may not belong to more than one group.

Pick Up Groups

To program the pick-up group, press 'PICK-UP', then the dialling key of the group number (1 to 9). Next press the extension keys of the group members. A RED LED GLOWING indication is given for group members.

To remove extensions from a group, press the extension keys until the RED LED goes out.

When the required group has been formed, press 'HOLD' to store the information.

Telephone Receptionist

To program the system for a telephone/receptionist, enter programming mode at the programming extension.

Press 'TRANS' then the extension key of the extension which is to become the telephone/receptionist, then press '0'. Programming is completed by pressing 'HOLD', and dial tone is given to indicate a successful transaction.

To cancel a telephone/receptionist, press 'TRANS' then press dial key '0', followed by 'HOLD'.

Changing Extensions

This facility is used when two people swop offices and want to retain their extension numbers.

To program the system with the change, press 'TRANS' then the extension keys of the two extensions. Press 'HOLD' to complete the transfer.

Erasing an Extensions Programming

This will revert an extension to its initialised state, ie Class of Service '0', with no abbreviated dialling.
Press 'TRANS', then the extension key of the extension followed by 'HOLD'.

Printer

A printer which conforms to BS 6301 may be connected to the V24 connector. This is used for call logging and error messages.

Printer Speed

The normal printer speed (default) is 1200bauds. This may be changed if the printer fitted works at a different speed.
The speed is changed by pressing, 'RECALL', then

9 0 0 to give a baud rate of 9600
9 0 1 to give a baud rate of 4800
9 0 2 to give a baud rate of 2400
9 0 3 to give a baud rate of 1200 (default)
9 0 4 to give a baud rate of 600
9 0 5 to give a baud rate of 300
9 0 6 to give a baud rate of 150
9 0 7 to give a baud rate of 75

Press 'HOLD' to store the speed.

Setting Time and Date

MINUTES, Press 'RECALL' then 9 5 followed by the minutes (00 to 59), then 'HOLD'.

HOURS, Press 'RECALL' then 9 6 followed by the hours (00 to 23), then 'HOLD'.

DAY, Press 'RECALL' then 9 7 followed by the day (01 to 31), then 'HOLD'.

MONTH, Press 'RECALL' then 9 8 followed by the month (01 to 12), then 'HOLD'.

YEAR, Press 'RECALL' then 9 9 followed by the year (84 to 99), then 'HOLD'.

System Abbreviated Dialling

This facility is obtained using normal mode (not programming) at the programming extension.

Commonly dialled numbers may be held in a store, which can be accessed by dialling a two digit code (50 to 99) from any extension. The capacity of the store is limited by the stored number length. ie Fewer International numbers can be stored than STD numbers. When the store has reached capacity, facility unavailable tone is given to prevent further attempts to store.

To store the required number, remove the handset and press 'ABDIAL'. Then using the dialling keys enter the two digit code which is to be used (50 to 99), followed by the required number then press 'HOLD'. A 3 second pause may be programmed between digits by pressing 'ABDIAL'. This is often required after the first digit on PBX working.

To erase a number press 'ABDIAL', followed by the two digit code, then press 'CANCEL'.

To use this facility, remove the handset (or press 'H/FREE') and obtain access to a trunk in the normal manner. Press 'ABDIAL', then using the dialling keys press the two digit code for the required number.

