

NOTES

1. This diagram with circuit operation notes is of a typical installation with one private circuit and one or more non-multiple extensions. The private circuit is numbered extension 10.
2. Relay Unit Q 524 must be fitted beyond the last multiple station, see Dgms. Q 502 and 503.
3. Only when the extension of exchange calls over the private circuit is authorized on the Advice Note should straps between terminals 74-84 and 75-85 be provided.
4. NIGHT SERVICE extension of exchange calls is not available using this method of signalling.
5. For arrangements of straps in Relay Unit Q 524 see Dgms. Q 503 and 561.

CIRCUIT OPERATION

INDEX

- 1.0 OUTGOING CALL ON TIE-LINE (PRIVATE CIRCUIT)
 - 1.1 DISTANT END ANSWERS
- 2.0 INCOMING CALL ON TIE-LINE (PRIVATE CIRCUIT)
 - 2.1 TRANSFER OF CALL
 - 2.2 RECALL OF MAIN
 - 2.3 CLEARING
- 3.0 EXCHANGE CALLS

P.O. TELECOMMS H.Q. PAPER: W CIRCLTN: GENERAL	ISSUE		
		<i>WPA</i>	<i>2.4.68.</i>
		TDI.4.3.	2.4.68.

CIRCUIT OPERATION

1.0 OUTGOING CALL ON TIE-LINE (PRIVATE CIRCUIT)

At a multiple station lifting the handset and overpressing the local key connects earth to B wire, resistance battery to A wire, of multiple pair to Relay Unit Q 524. Relays RC, (via diode D1), and F operate. Contact F1 operates relay FR. Contact FR4 connects relay LA to A wire of line circuit. Relay LA operates. Release of overpress of local key connects normal conditions, earth A wire, battery B wire, and telephone circuit, to multiple pair of Relay Unit Q 524. Relay RC releases.

1.1 DISTANT END ANSWERS

Earth on B wire from distant end operates relay LB. Contact LB2 operates relay RO. Conversation can now take place.

2.0 INCOMING CALL ON TIE-LINE (PRIVATE CIRCUIT)

Earth on B wire from distant end operates relay LB. Contact LB1 operates relay RR. Contact RR2 lights calling lamp, RR3 operates buzzer, in Control Unit Q 537. Main station answers by lifting handset and operating local key which connects earth A wire, battery B wire, telephone circuit between wires, to multiple pair of Relay Unit Q 524. Relay F operates. Contact F1 operates relay FR. Contact FR2 releases relay RR and operates relay RO. Contact FR4 connects relay LA to A wire of line circuit. Relay LA operates. Contacts RR2 and RR3 disconnect calling lamp and buzzer in Control Unit Q 537. Conversation can now take place.

2.1 TRANSFER OF CALL TO

(a) Multiple Station

CONNECT and TEST key is operated on Control Unit Q 537. Relay F releases when main station calls the wanted station. Relay FR holds to earth on S wire from Control Unit Q 537 via contacts FR3, ELR5, EL2 and F1. Relay F will re-operate when station seizes circuit. CONNECT and TEST key is restored.

(b) Non-Multiple Extension

As in (a) CONNECT and TEST key is operated and relay F will release whilst non-multiple extension is being called. When extension answers, its CONNECT and TEST key is operated to complete speech path.

2.2 RECALL OF MAIN STATION BY MULTIPLE STATION

Overpress of local key at multiple station connects earth to B wire, resistance battery to A wire, of multiple pair, holding

relay F and operating relay RC. Contact RC4 operates relay RR. Contacts RR2 and RR3 light call lamp and operate buzzer in Control Unit Q 537. Release of overpress restores normal conditions to multiple pair releasing relay RC. Contact RC4 releases relay RR, contacts RR2 and RR3 disconnect call lamp and buzzer.

2.3 CLEARING

MULTIPLE STATION CALL

(a) Distant end clears first. Removal of earth from B wire of line circuit from distant end releases relay LB. Contact LB2 releases relay RO. When handset at multiple station is replaced, relay F releases. Contact F1 releases relay FR. Contact FR4 disconnects relay LA from line circuit, relay LA releases. Circuit now normal.

(b) Multiple station clears first. Replacing of handset releases relay F. Contact F1 releases relay FR. Contact FR4 disconnects relay LA from line circuit, relay LA releases. When distant end clears, removal of earth from B wire of line circuit releases relay LB. Contact LB2 releases relay RO. Circuit now normal.

NON-MULTIPLE EXTENSION CALL

(c) Distant end clears first. Removal of earth from B wire of line circuit from distant end releases relay LB. Contact LB2 releases relay RO. Contact RO4 operates relay RR via CONNECT and TEST key contact in Control Unit Q 537. Contacts RR2 and RR3 light call lamp and operate buzzer in Control Unit Q 537. When the CONNECT and TEST key is restored, relays RR and FR release. Contacts RR2 and RR3 disconnect call lamp and buzzer. Contact FR4 disconnects relay LA from line circuit, relay LA releases. Circuit now normal.

(d) Non-multiple extension clears first. Clear from extension will cause main station to restore CONNECT and TEST key on Control Unit Q 537. Relay FR will release. Contact FR4 disconnects relay LA from line circuit, relay LA releases. When distant end clears, removal of earth from B wire of line circuit releases relay LB. Contact LB2 releases relay RO. Circuit is now normal.

3.0 EXCHANGE CALLS (NOTES 3 & 4)

Exchange calls may be extended to tie-line from
(a) exchange line 1, or (b) exchange line 2. Distant end is first called as in Pars. 1.0 and 1.1.

(a) Exchange Line 1.

CONNECT and TEST key is operated on Control Unit Q 537, followed by operation of TRANSFER 1 key. Earth via 10 X 1 lead operates relay EA. Contact EA6 operates relay EL to resistance battery on LA lead from Relay Unit Q 516. Contact EL1 operates relay ELR. Contact EL4 earths XA multiple lead, EL5 earths LPAC multiple lead. Contacts ELR1 and ELR2 switch speech path to exchange line, ELR3 and ELR4 disconnect intercom, apply busy condition and release relay F, contact ELR5 operates relay RR to earth via CONNECT and TEST key. Contacts RR2 and RR3 light call lamp and operate the buzzer in Control Unit Q 537. TRANSFER 1 and CONNECT and TEST keys are restored, relay RR releases. Contacts RR2 and RR3 disconnect call lamp and buzzer. When handset is replaced, or release button operated, on multiple station, exchange line is connected to circuit. Distant end now holds exchange line. Clearing of the distant end releases relay LB. Contact LB2 releases relay RO. Contact RO1 releases exchange line, RO3 releases relay EL, RO5 releases relay EA. Contact EL1 releases relay ELR, EL2 releases relay FR. Contacts EL4 and EL5 remove earths from XA and LPAC multiple leads. Contact FR4 disconnects relay LA from line circuit, relay LA releases. Circuit now normal.

(b) Exchange Line 2.

CONNECT and TEST key is operated on Control Unit Q 537 followed by operation of TRANSFER 2 key. Earth via 10 X 2 lead operates relay EB. Contact EB7 operates relay EL, via LB lead, to resistance battery in Relay Unit Q 516. Contact EL1 operates relay ELR. Contact EL4 earths XB lead, EL5 earths LPBC lead, in multiple cable. Contacts ELR1 and ELR2 switch speech circuit to exchange line. Contact ELR3 and ELR4 disconnect intercom, apply busy condition and release relay F. Contact ELR5 operates relay RR to earth via CONNECT and TEST key. Contacts RR2 & RR3 light call lamp and operate buzzer in Control Unit Q 537. TRANSFER 2 and CONNECT and TEST keys are restored, relay RR releases. Contacts RR2 and RR3 disconnect call lamp and buzzer. When handset is replaced, or release button operated, on multiple station, exchange line is connected to circuit. Distant end now holds exchange line. Clearing of the distant end releases relay LB. Contact LB2 releases relay RO. Contact RO1 releases exchange line, RO3 releases relay EL, RO5 releases relay EB. Contact EL1 releases relay ELR, EL2 releases relay FR. Contacts EB1 and EB2 remove earths from XB and LPBC multiple leads. Contact FR4 disconnects relay LA from line circuit, relay LA releases. Circuit now normal.

RELAY UNIT Q516
(DGM. Q516)

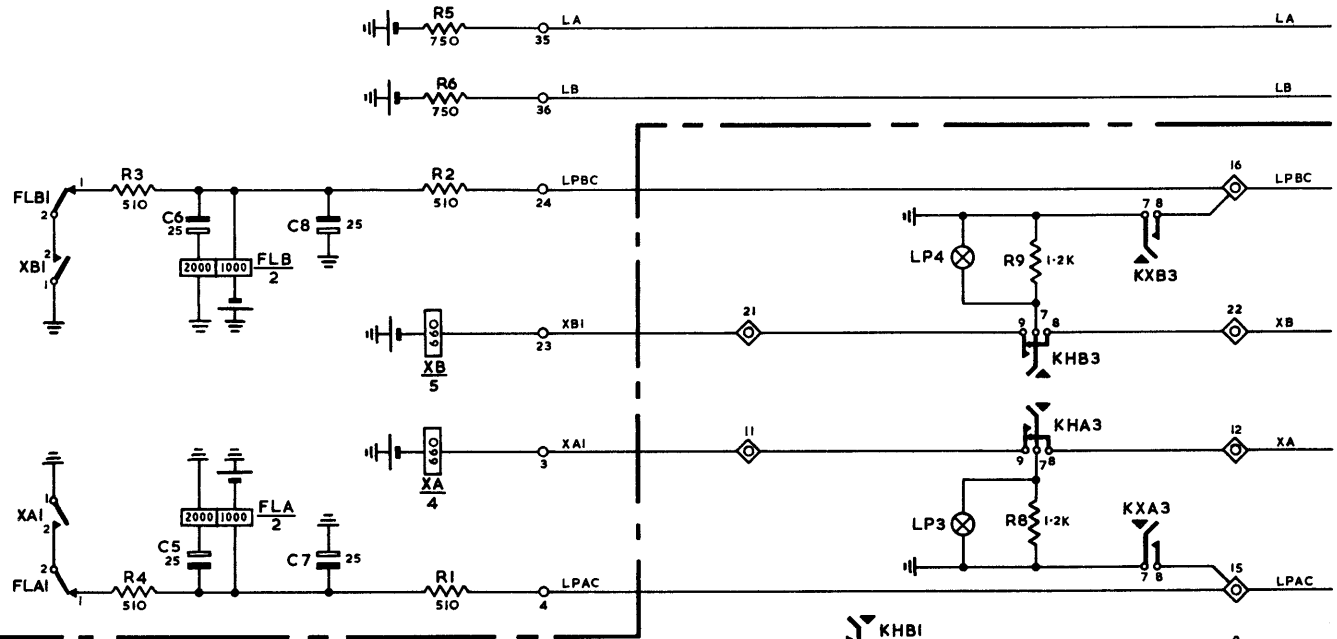

TELEPHONE INTERCOM No. 4/1...
(DGM. Q540)

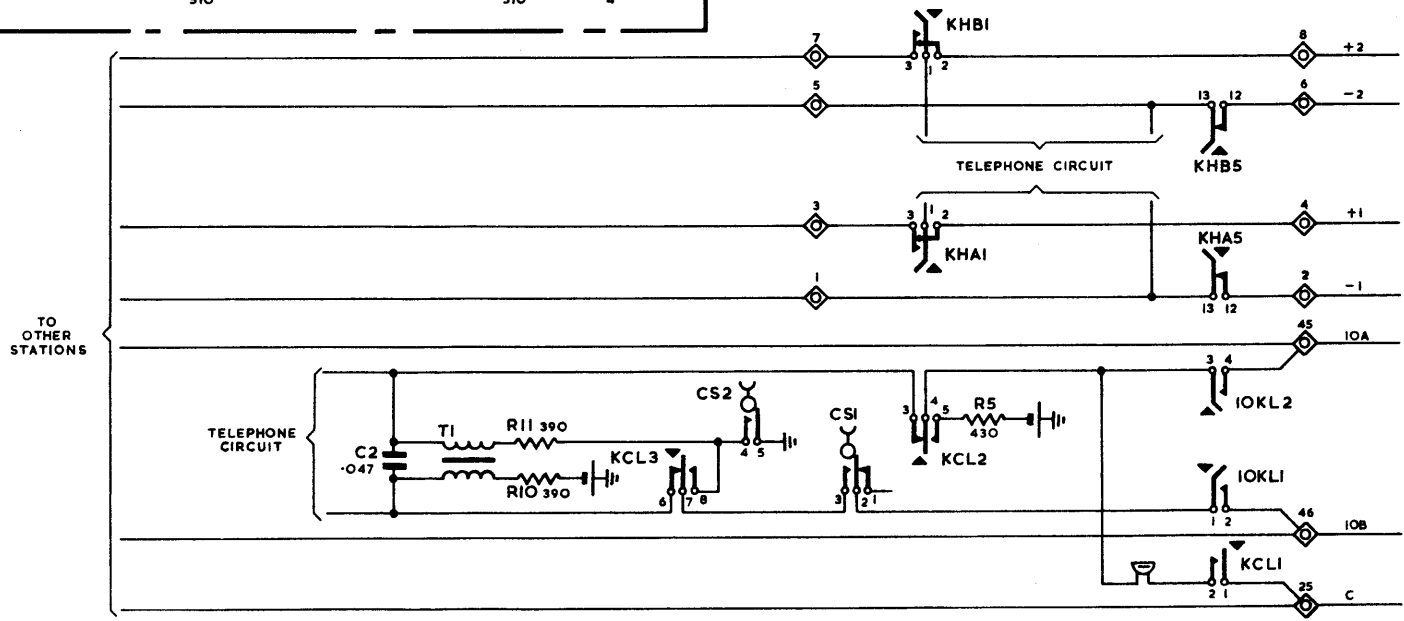

RELAY UNIT Q524
(DGM. Q524)

CONTROL UNIT Q537
(DGM. Q537)

