

INSTALLATION OF FILTER UNITS CARRIER SYSTEM WB 900

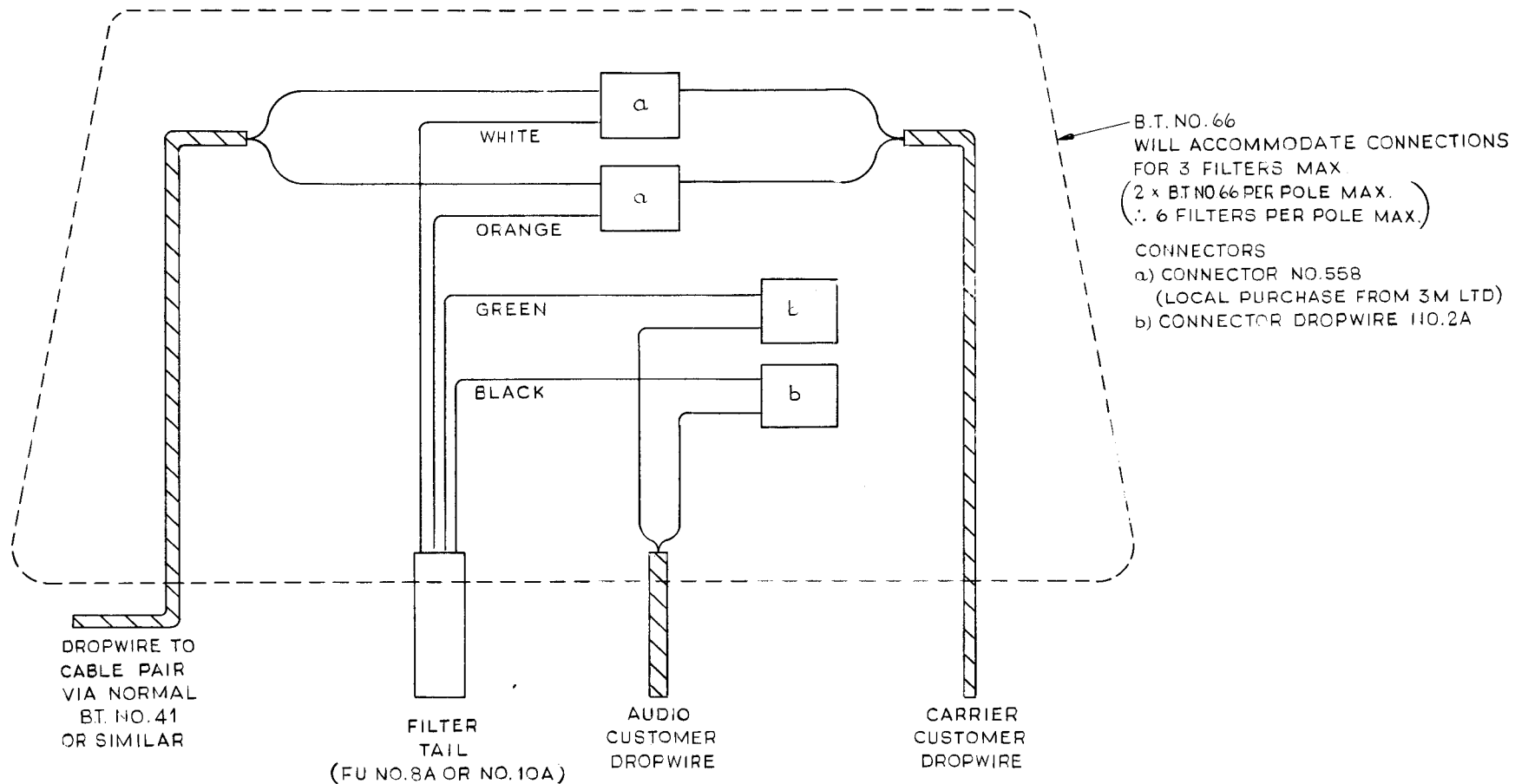

RECOMMENDED METHOD FOR WB 900 FILTER CONNECTIONS
(OVERHEAD CONSTRUCTION)

BRITISH TELECOMMS HQRS			
COLOUR :- W	ISSUE		
DISTRIBUTION:- GENERAL	A	Final Drawings REDRAWN	T6.1.3 16-8-82

INSTALLATION OF FILTER UNITS
CARRIER SYSTEM WB 900

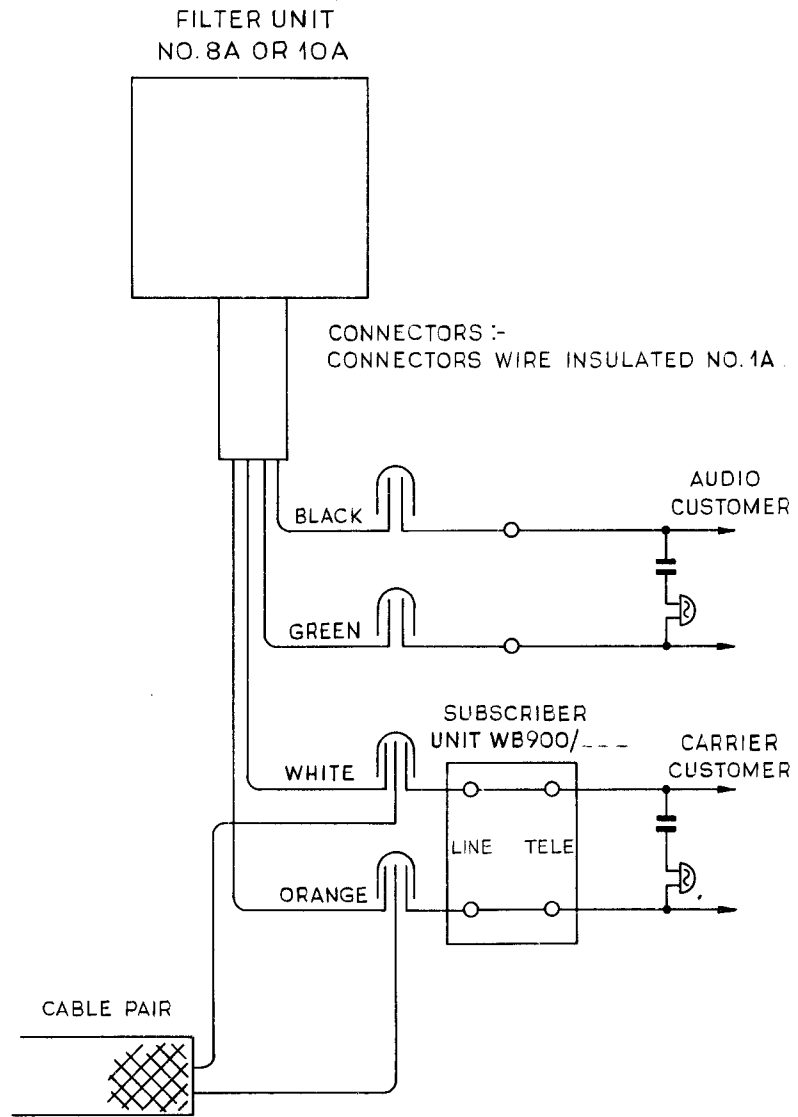

RECOMMENDED METHOD OF CONNECTING FILTERS
UNDERGROUND CONSTRUCTION

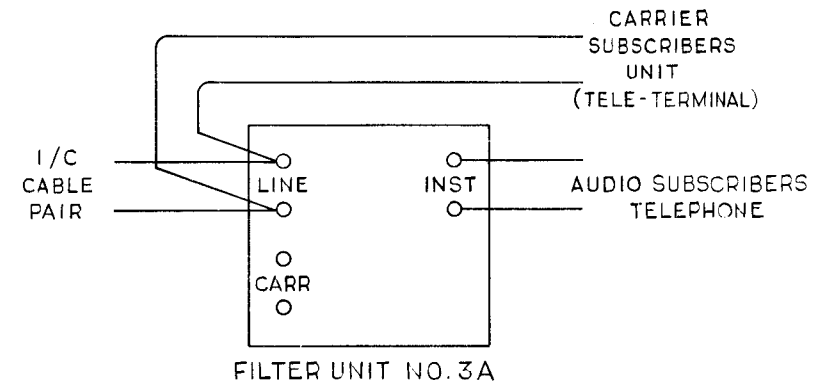

NOTE:-
'CARR' TERMINAL MUST NOT BE USED (DC BLOCKING INCLUDED FOR WB 400 SYSTEM.)

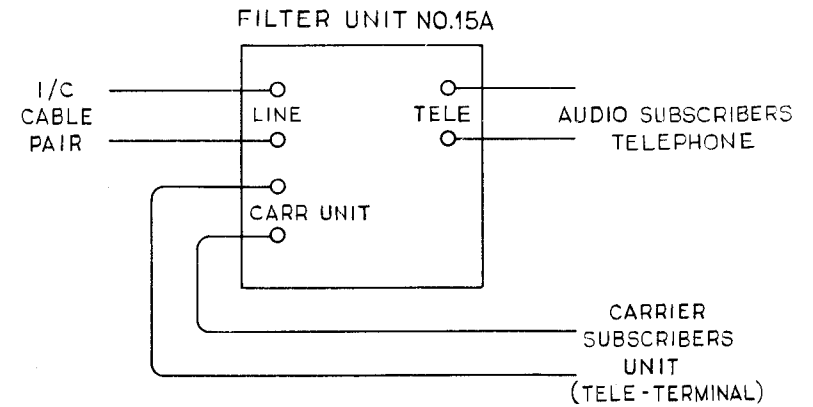

RECOMMENDED METHOD FOR WB900
FILTER CONNECTIONS (INTERNAL)