

SPECIAL RANGE TELEPHONES
AUTODIAL No. 301A OR 302A CONNECTED TO DIRECT EXCHANGE LINES AND EXTENSION PLAN
ARRANGEMENTS 1A AND 4. EXCLUSIVE AND SHARED SERVICE (SEPARATE METERING) USING
TELEPHONE SRI...B

NOTES :-

- 1 This diagram is to be used in conjunction with Diagram N4902
- 2 See Diagram N2312 for details of Autodials Nos. 301A and 302A.
- 3 The Autodial No. 301A is provided with a 5-way cord, the black conductor being omitted.
- 4 The orange, blue and (where provided) black cord conductors of the autodial should be insulated at the block terminal or bell-set.

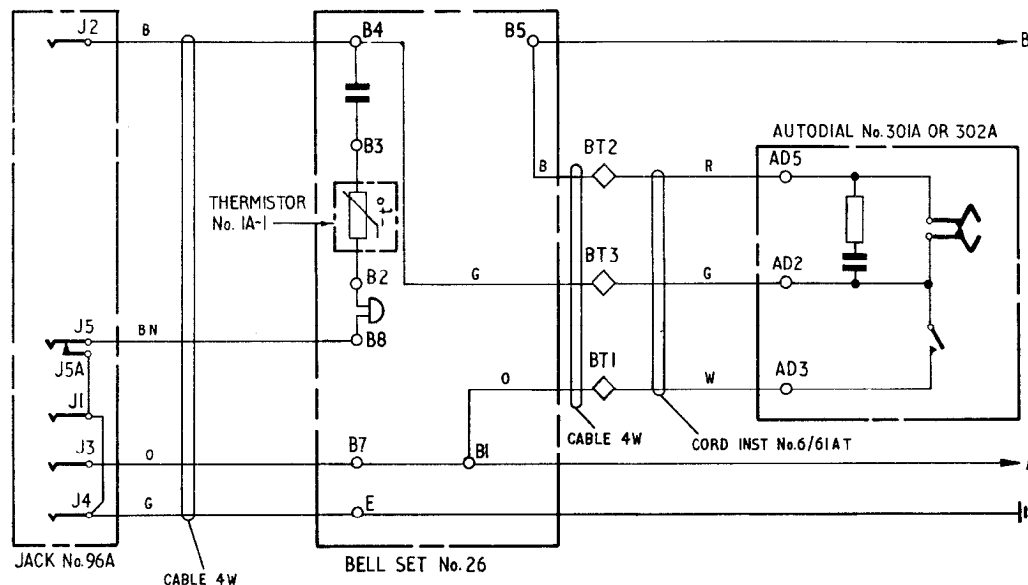

FIG. 1 AUTODIAL No. 301A OR 302A CONNECTED TO A DIRECT EXCHANGE LINE

ADDITIONAL APPARATUS REQUIRED :-
Autodial No. 301A or 302A
Block Terminal No. 52A

SHARED SERVICE (SEPARATE METERING)
Connexions as shown.

EXCLUSIVE SERVICE

Earth and green cable connexions to E and J4 omitted, J1 - J3 - J4 strapped.
Thermistor No. 1A-1 omitted. B2 - B3 strapped.

NOTE :-

See Diagram N4902 for details of telephone

PO. TELECOMMS. HQRS.			
PAPER:- R	ISSUE		
DISTN:- NIL		TD 7-1-3	25-4-77

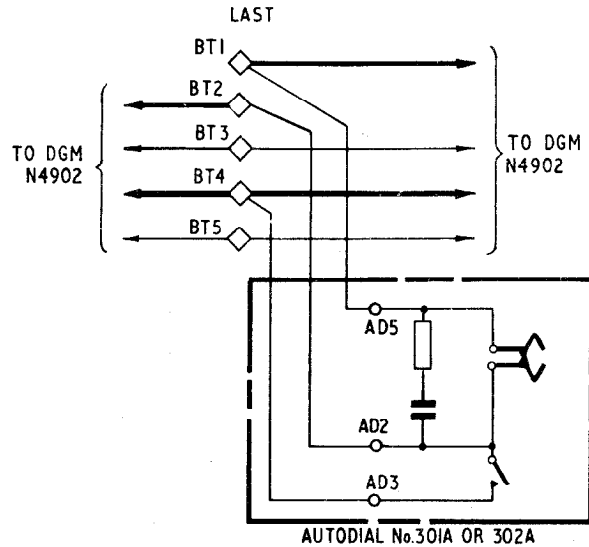

FIG. 2 USING TELEPHONE SR I... B
SHARED SERVICE (SEPARATE METERING)
Connexions as shown.
EXCLUSIVE SERVICE
Connexions to BT5 omitted.

AUTODIAL No. 301A OR 302A CONNECTED TO PLAN IA EXPLANATORY

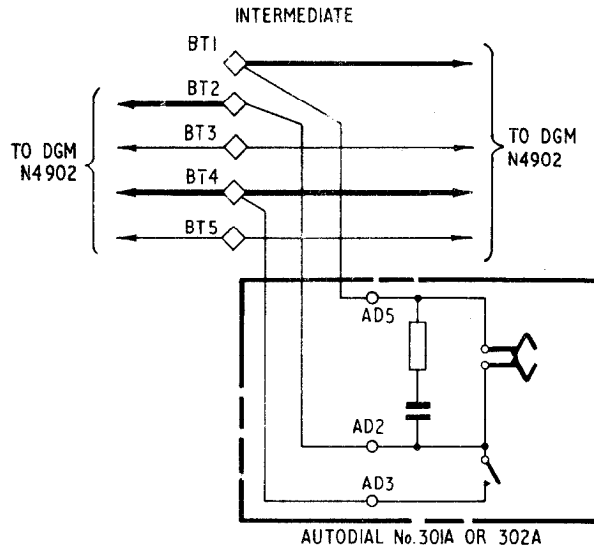

FIG. 3 USING TELEPHONE SR I... B
SHARED SERVICE (SEPARATE METERING)
Connexions as shown.
EXCLUSIVE SERVICE
Connexions to BT5 omitted

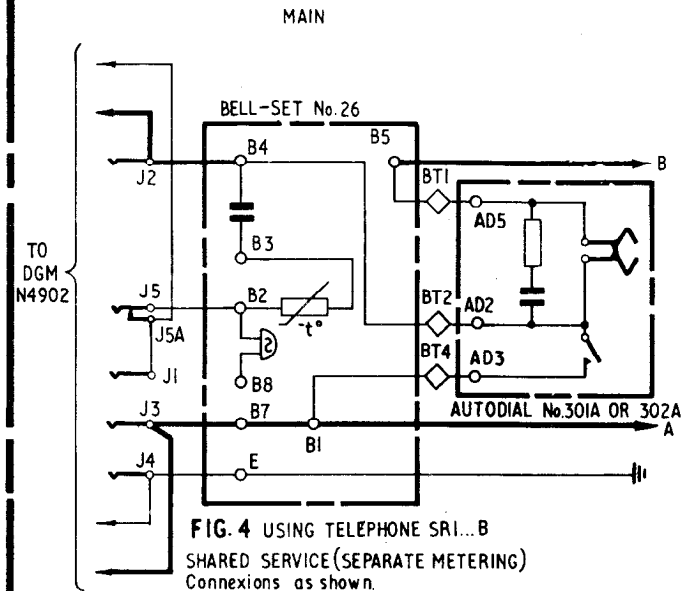

FIG. 4 USING TELEPHONE SR I... B
SHARED SERVICE (SEPARATE METERING)
Connexions as shown.
EXCLUSIVE SERVICE
Earth and connexions to E and J4 omitted,
J3-J4 strapped.
Thermistor No. 1A-1 omitted. B2 - B3 strapped

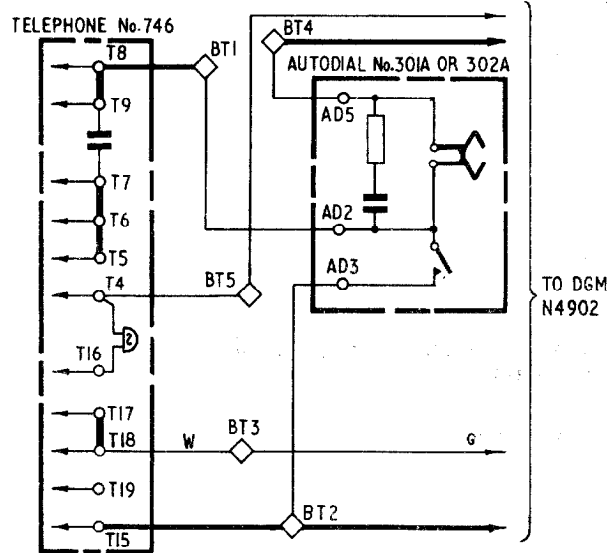

FIG. 5 USING TELEPHONE No. 746
SHARED SERVICE (SEPARATE METERING)
Connexions as shown.
EXCLUSIVE SERVICE
Green cable connexion to BT3 omitted. Strap T17-T18 omitted.
T18-T19 and BT2-BT3 strapped.
BT2 connected to T17 instead of to T15.

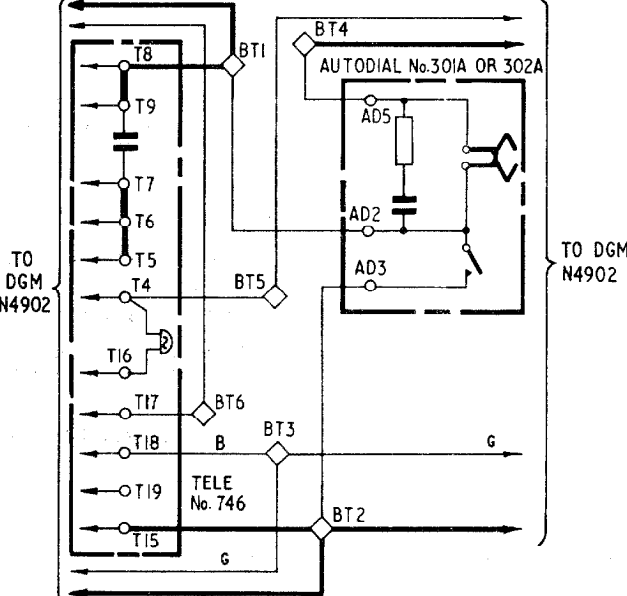

FIG. 6 USING TELEPHONE No. 746
SHARED SERVICE (SEPARATE METERING)
Connexions as shown.
EXCLUSIVE SERVICE
Green cable connexions to BT3 omitted.
T18-T19 and BT2-BT3 strapped.

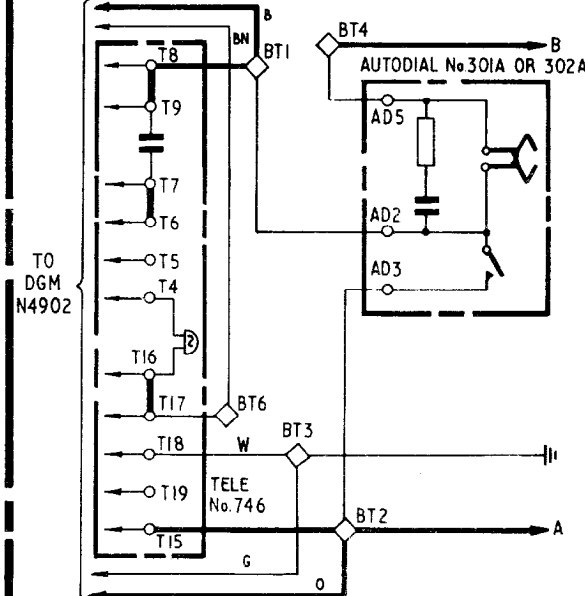

FIG. 7 USING TELEPHONE No. 746
SHARED SERVICE (SEPARATE METERING)
Connexions as shown.
EXCLUSIVE SERVICE
Earth and green cable connexions to BT3 omitted.
T4-T5, T18-T19 and BT2-BT3 strapped.

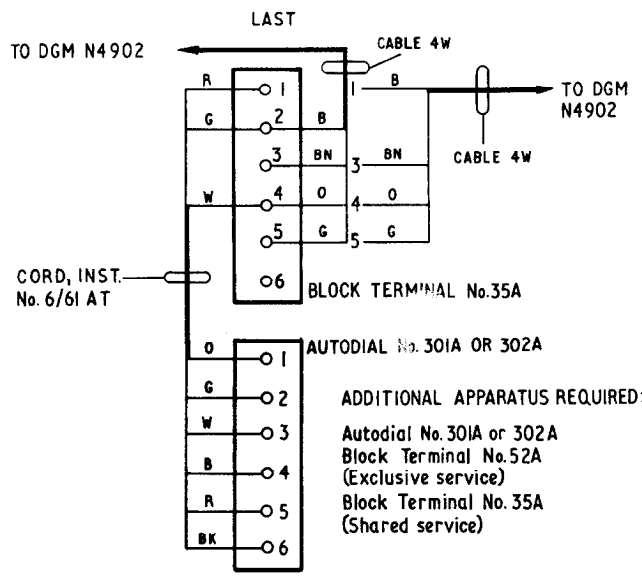

FIG. 8 USING TELEPHONE SRI...B
 SHARED SERVICE (SEPARATE METERING)
 Connexions as shown.
 EXCLUSIVE SERVICE
 Green cable connexionsto BT5 omitted.

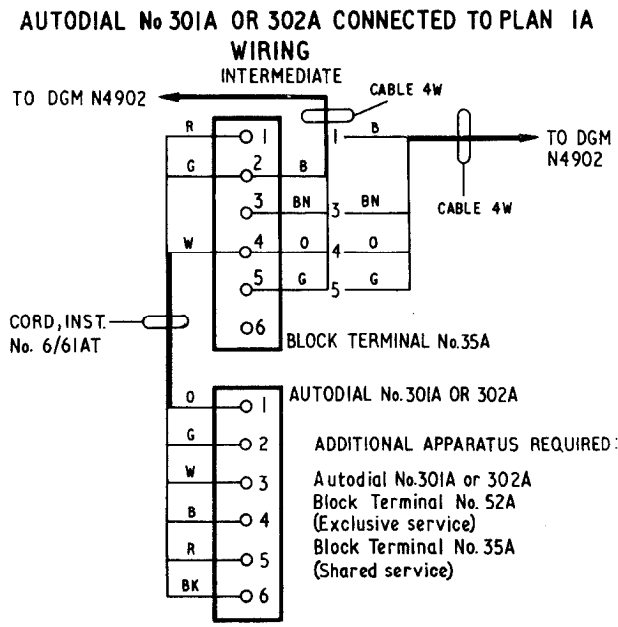

FIG. 9 USING TELEPHONE SRI...B
 SHARED SERVICE (SEPARATE METERING)
 Connexions as shown.
 EXCLUSIVE SERVICE
 Green cable connexionsto BT5 omitted.

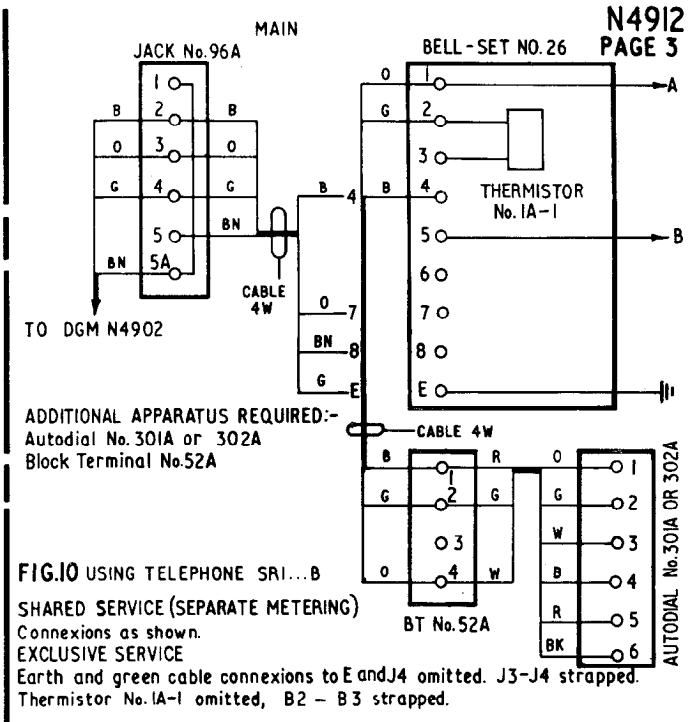

FIG. 10 USING TELEPHONE SRI...B
 SHARED SERVICE (SEPARATE METERING)
 Connexions as shown.
 EXCLUSIVE SERVICE
 Earth and green cable connexions to E and J4 omitted. J3-J4 strapped.
 Thermistor No. IA-1 omitted, B2 - B3 strapped.

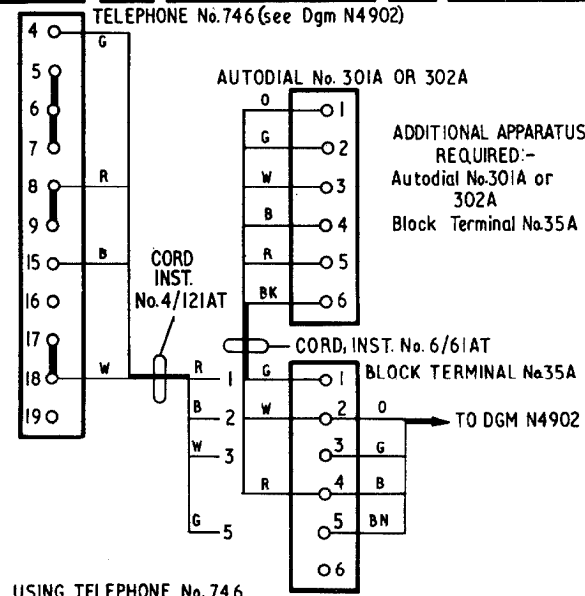

FIG. 11 USING TELEPHONE No. 746
 SHARED SERVICE (SEPARATE METERING)
 Connexions as shown
 EXCLUSIVE SERVICE
 Green cable connexion to BT3 omitted. Strap T17-T18 omitted, T18-T19 and BT2-BT3 strapped. Shift blue cord conductor from T15 to T17

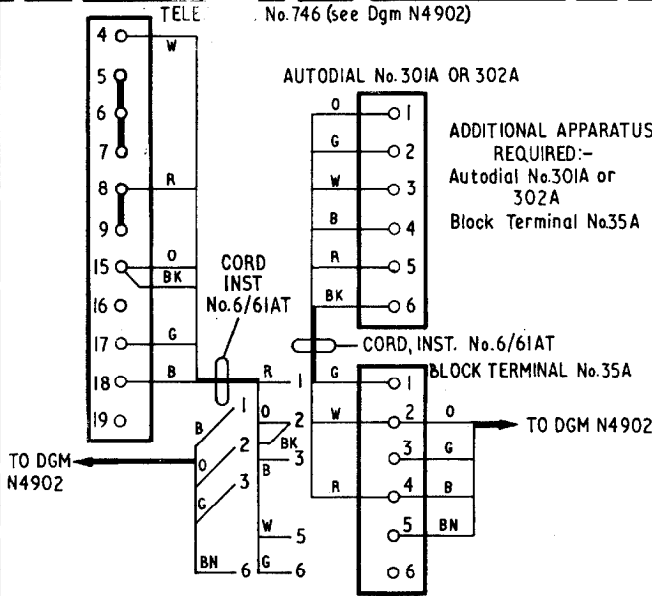

FIG. 12 USING TELEPHONE No. 746
 SHARED SERVICE (SEPARATE METERING)
 Connexions as shown
 EXCLUSIVE SERVICE
 Green cable connexions to BT3 omitted. Cord, Inst. No. 4/121AT used in lieu, omitting orange and black connexions to BT2 and T15. T18-T19 and BT2-BT3 strapped.

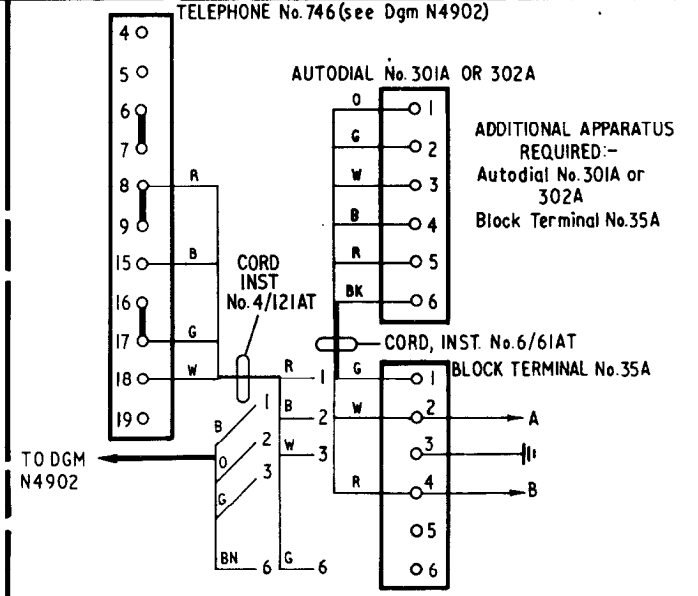

FIG. 13 USING TELEPHONE No. 746
 SHARED SERVICE (SEPARATE METERING)
 Connexions as shown
 EXCLUSIVE SERVICE
 Earth and green cable connexions to BT3 omitted. T4-T5, T18-T19 and BT2-BT3 strapped.

AUTODIAL No.301A OR 302A CONNECTED TO PLAN 4
EXPLANATORY

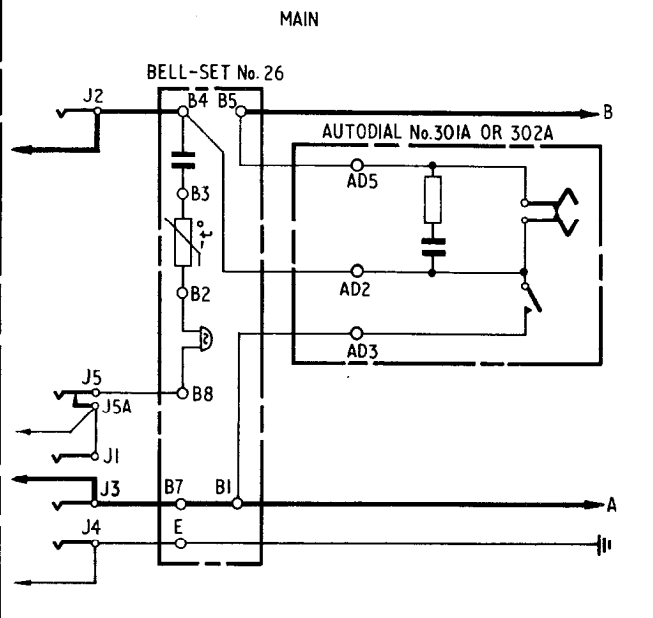
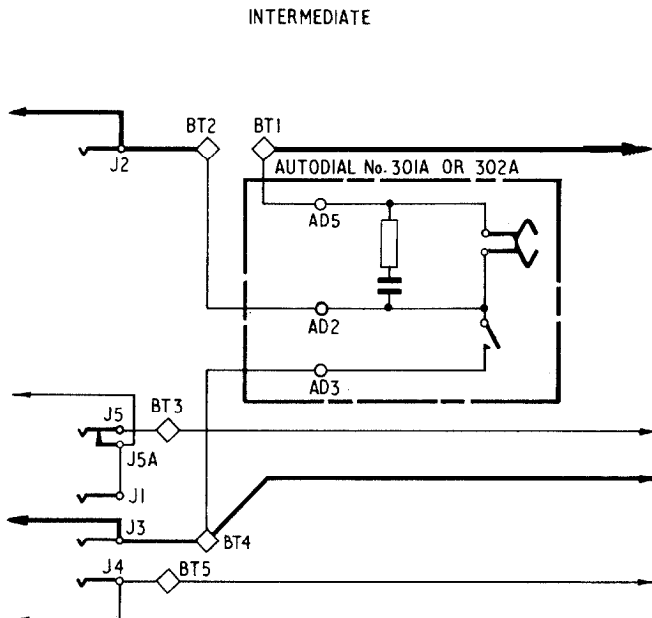
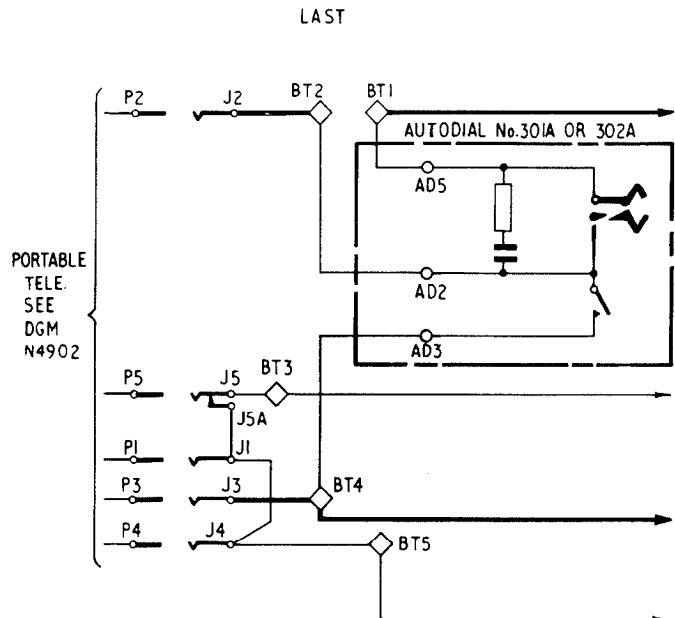

FIG. 14

FIG. 15

FIG. 16

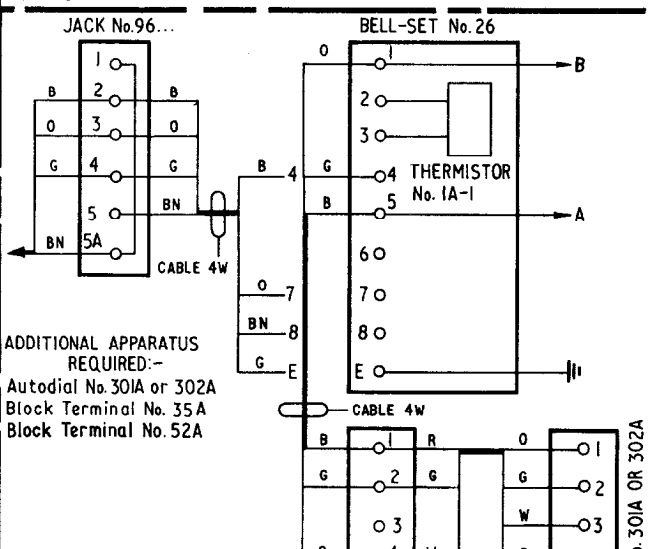
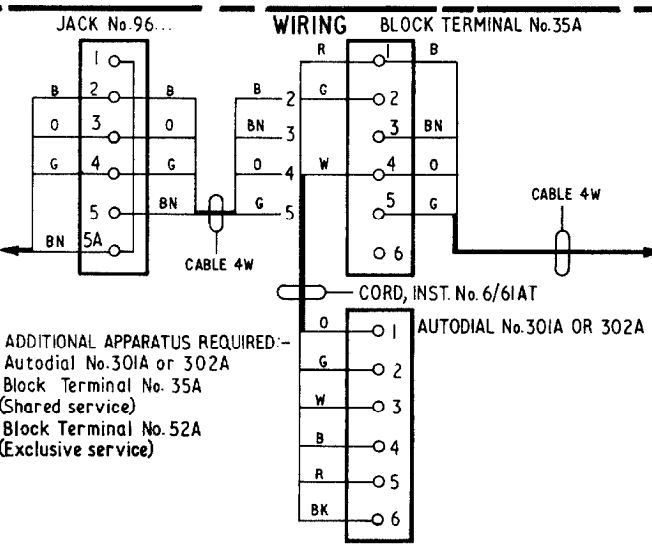
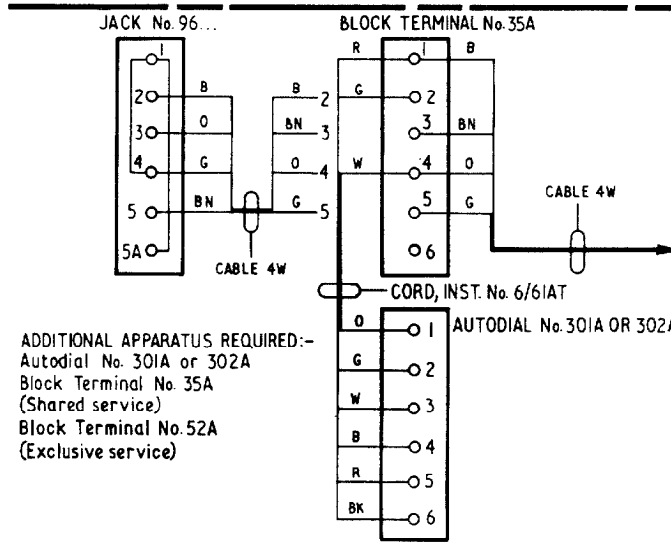

FIG. 17
SHARED SERVICE (SEPARATE METERING)
Connections as shown
EXCLUSIVE SERVICE
Green cable connexions to BT5 and J4 omitted.
J3 and J4 strapped.

FIG. 18
SHARED SERVICE (SEPARATE METERING)
Connections as shown
EXCLUSIVE SERVICE
Green cable connexions to BT5 and J4 omitted.
J3 and J4 strapped.

FIG. 19
SHARED SERVICE (SEPARATE METERING)
Connections as shown
EXCLUSIVE SERVICE
Earth and green cable connexions to J4 and E omitted.
J3 and J4 strapped. Thermistor No. 1A-1 omitted. B2-B3 strapped.