

SPECIAL RANGE TELEPHONES

AUTODIAL No 301A OR 302A CONNECTED TO DIRECT EXCHANGE LINES AND EXTENSION PLAN ARRANGEMENTS 1A AND 4. EXCLUSIVE AND SHARED SERVICE (SEPARATE METERING) USING TELEPHONE SRI...A

NOTES :-

- 1 This diagram is to be used in conjunction with Diagram N4901.
- 2 See Diagram N2312 for details of Autodials Nos. 301A and 302A.
- 3 The Autodial No. 301A is provided with a 5-way cord, the black conductor being omitted.
- 4 The orange, blue and (where provided) black cord conductors of the autodial should be insulated at the block terminal or bell-set.

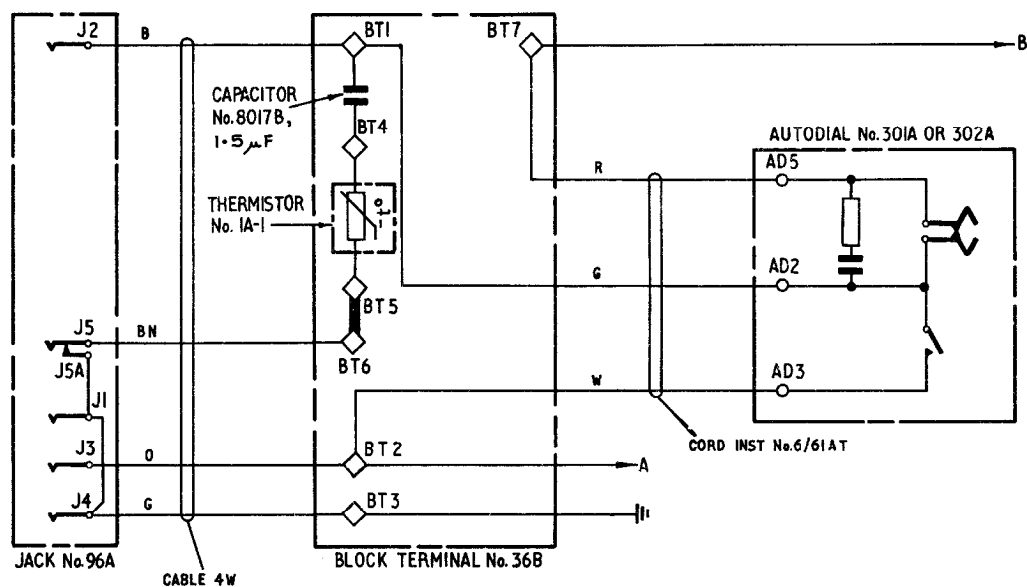

FIG. 1 AUTODIAL No. 301A OR 302A CONNECTED TO A DIRECT EXCHANGE LINE

ADDITIONAL APPARATUS REQUIRED:-

Autodial No. 301A or 302A.

SHARED SERVICE (SEPARATE METERING)

Connexions as shown.

EXCLUSIVE SERVICE

Earth and green cable connexions to BT 3 and J4 omitted, J1-J3-J4 strapped
Thermistor No. 1A-1 omitted. Capacitor No. 8017B connected between BT1 and BT5.

NOTE :-

A. See Diagram N4901, Fig1, for details of telephone.

PO TELECOMMS HQ,RS			
PAPER:- R	ISSUE		
DISTN:- NIL	A	VALUE OF CAPACITOR NO. 8017B ADDED. <i>S.A.H.</i>	24-1-78
			TD 7-1-3 9-5-77

AUTODIAL No. 301A OR 302A CONNECTED TO PLAN IA
EXPLANATORY

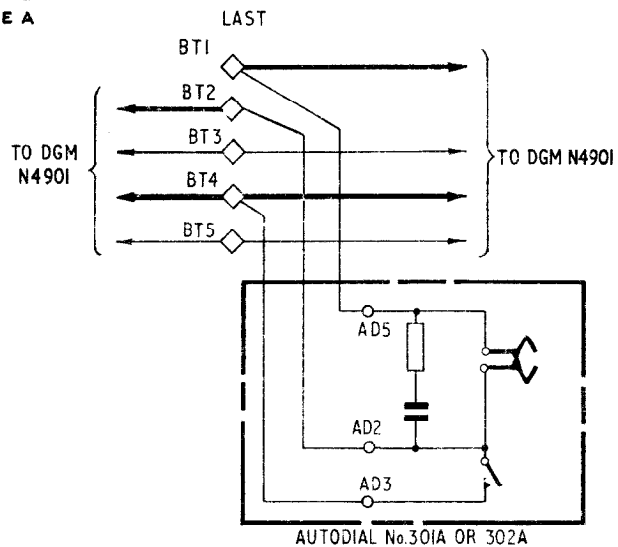

FIG. 2 USING TELEPHONE SR 1...A

SHARED SERVICE (SEPARATE METERING)
Connections as shown.
EXCLUSIVE SERVICE
Connections to BT5 omitted.

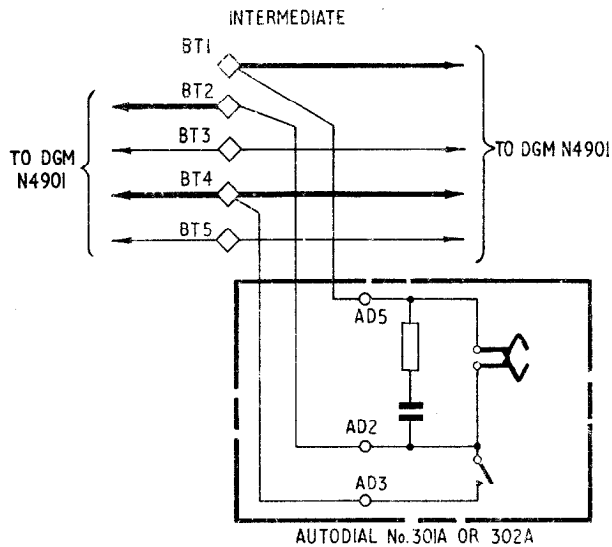

FIG. 3 USING TELEPHONE SR 1...A

SHARED SERVICE (SEPARATE METERING)
Connections as shown.
EXCLUSIVE SERVICE
Connections to BT5 omitted.

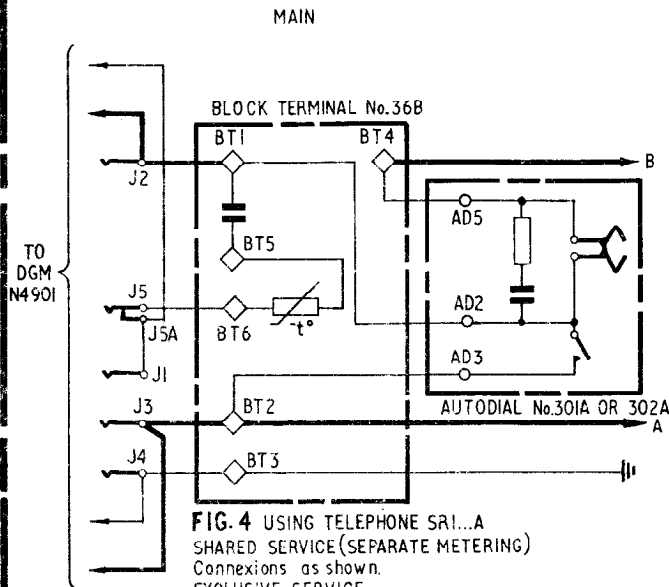

FIG. 4 USING TELEPHONE SR 1...A
SHARED SERVICE (SEPARATE METERING)
Connections as shown.
EXCLUSIVE SERVICE
Connections to BT3 and J4 omitted.
J3-J4 strapped.
Thermistor No. 1A-1 omitted.
BT5-BT6 strapped.

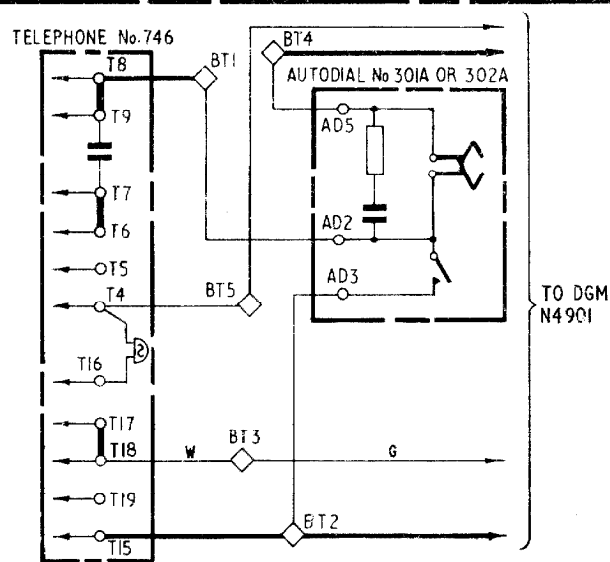

FIG. 5 USING TELEPHONE No. 746

SHARED SERVICE (SEPARATE METERING)
Connections as shown.
EXCLUSIVE SERVICE
Green cable connexion to BT3 omitted.
Strap T17-T18 omitted. T18-T19 and BT2-BT3 strapped. BT2 connected to T17.

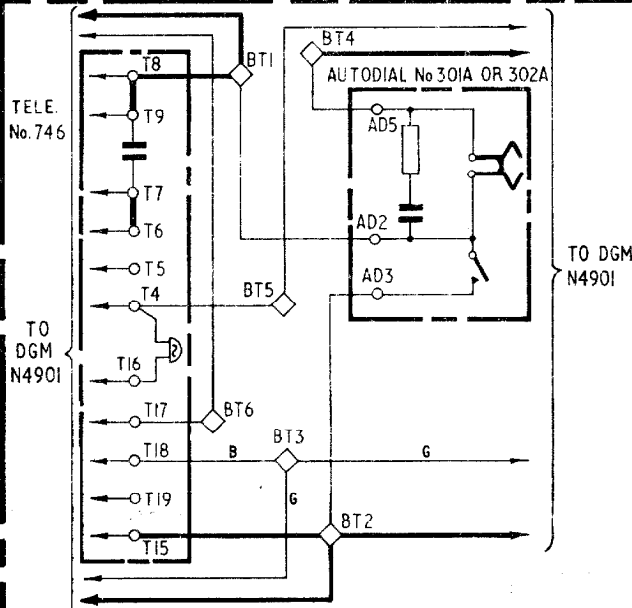

FIG. 6 USING TELEPHONE No. 746

SHARED SERVICE (SEPARATE METERING)
Connections as shown.
EXCLUSIVE SERVICE
Green cable connexions to BT3 omitted.
T18-T19 and BT2-BT3 strapped.

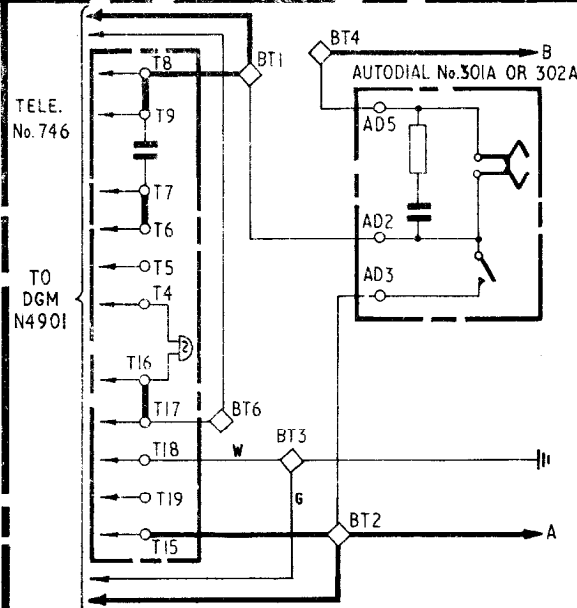

FIG. 7 USING TELEPHONE No. 746

SHARED SERVICE (SEPARATE METERING)
Connections as shown.
EXCLUSIVE SERVICE
Earth and green cable connexions to BT3 omitted.
T4-T5, T18-T19 and BT2-BT3 strapped.

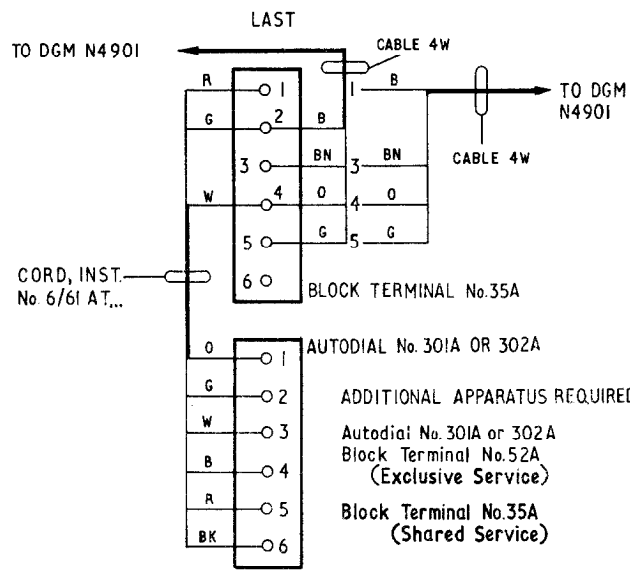

FIG. 8 USING TELEPHONE SRI...A
 SHARED SERVICE (SEPARATE METERING)
 Connexions as shown.
 EXCLUSIVE SERVICE
 Green cable connexions to BT5 omitted

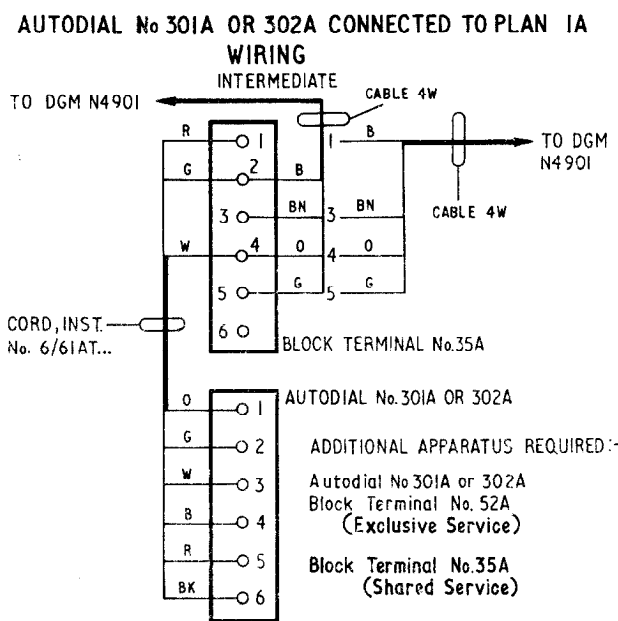

FIG. 9 USING TELEPHONE SRI...A
 SHARED SERVICE (SEPARATE METERING)
 Connexions as shown.
 EXCLUSIVE SERVICE
 Green cable connexions to BT5 omitted

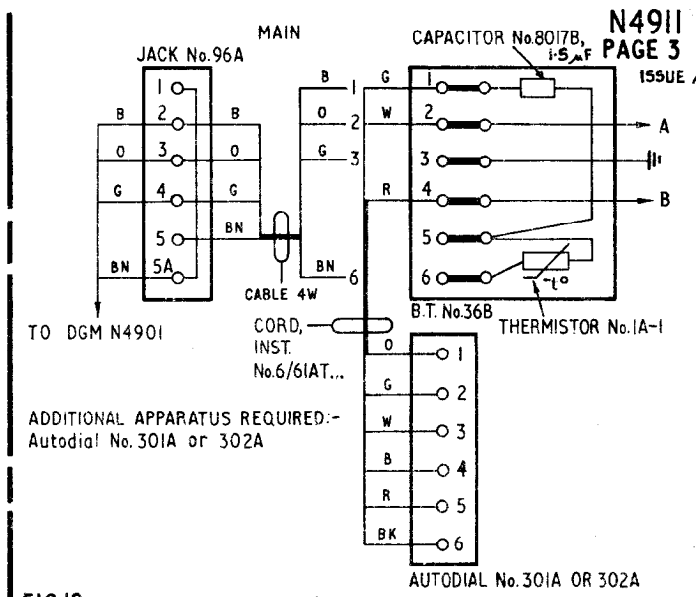

FIG. 10 USING TELEPHONE SRI...A
 SHARED SERVICE (SEPARATE METERING)
 Connexions as shown.
 EXCLUSIVE SERVICE
 Earth and green cable connexions to BT3, J4 omitted. J3-J4 strapped.
 Thermistor No. IA-1 omitted, BT5-BT6 strapped.

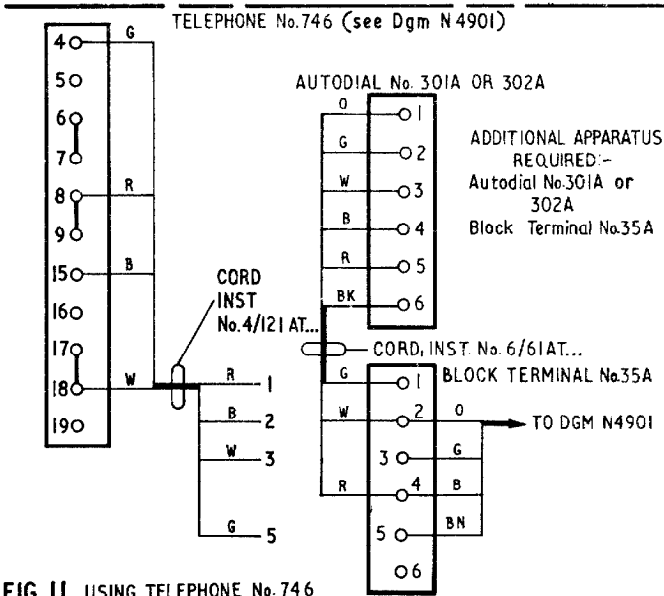

FIG. 11 USING TELEPHONE No. 746
 SHARED SERVICE (SEPARATE METERING)
 Connexions as shown
 EXCLUSIVE SERVICE
 Green cable connexion to BT3 omitted. Strap T17-T18 omitted, T18-T19 and BT2-BT3 strapped. Shift blue cord conductor from T15 to T17.

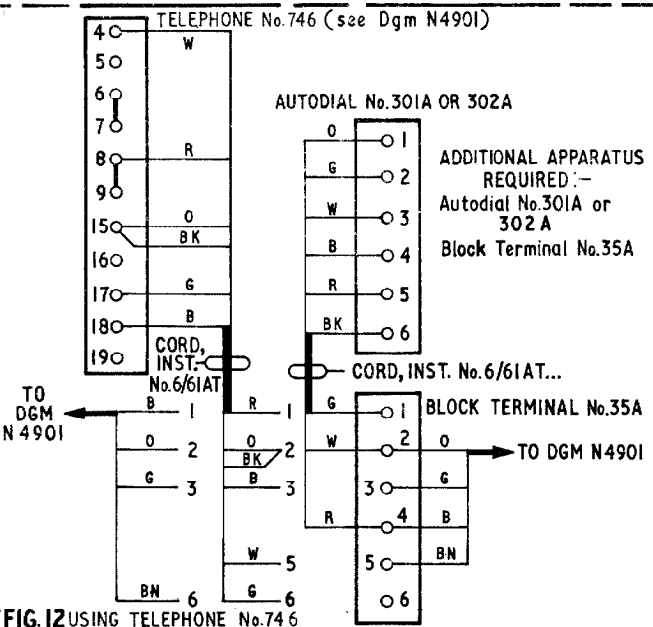

FIG. 12 USING TELEPHONE No. 746
 SHARED SERVICE (SEPARATE METERING)
 Connexions as shown
 EXCLUSIVE SERVICE
 Green cable connexions to BT3 omitted. Cord, Inst. No. 4/121 AT used in lieu of omitting orange and black connexions to BT2 and T15. T18-T19 and BT2-BT3 strapped.

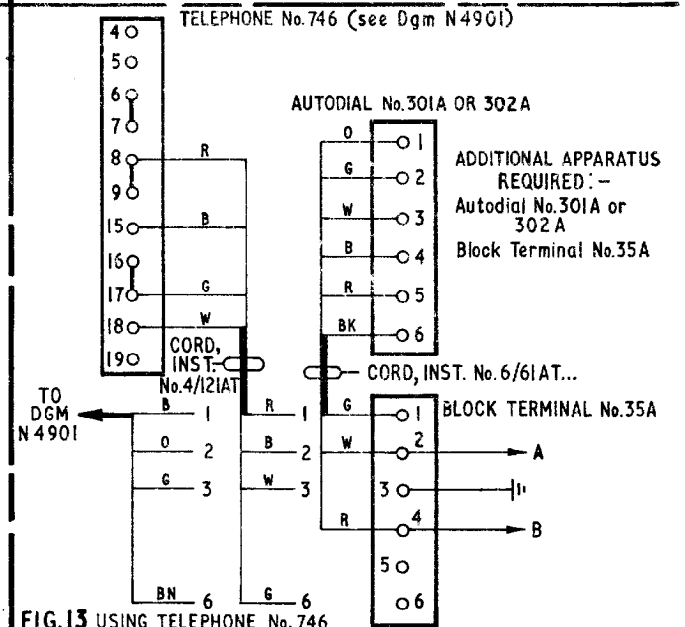

FIG. 13 USING TELEPHONE No. 746
 SHARED SERVICE (SEPARATE METERING)
 Connexions as shown
 EXCLUSIVE SERVICE
 Earth and green cable connexions to BT3 omitted. T4-T5, T18-T19 and BT2-BT3 strapped.

AUTODIAL No.301A OR 302A CONNECTED TO PLAN 4
EXPLANATORY

LAST

INTERMEDIATE

MAIN

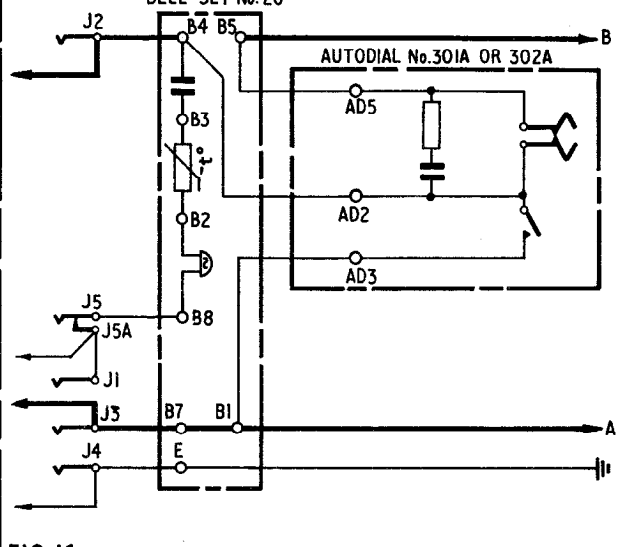
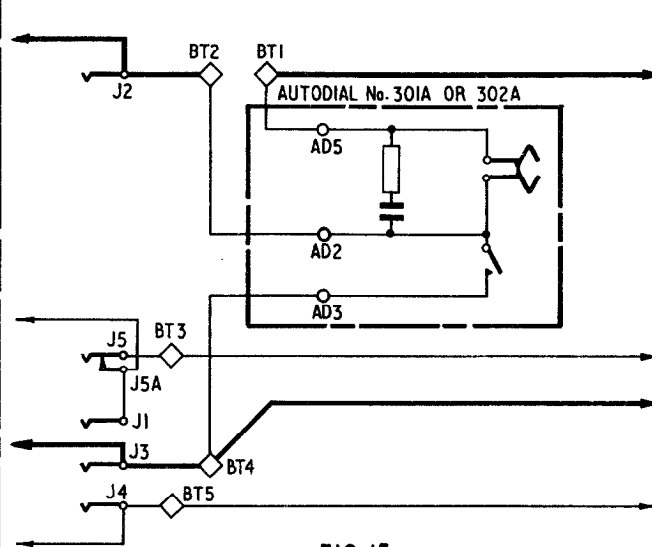
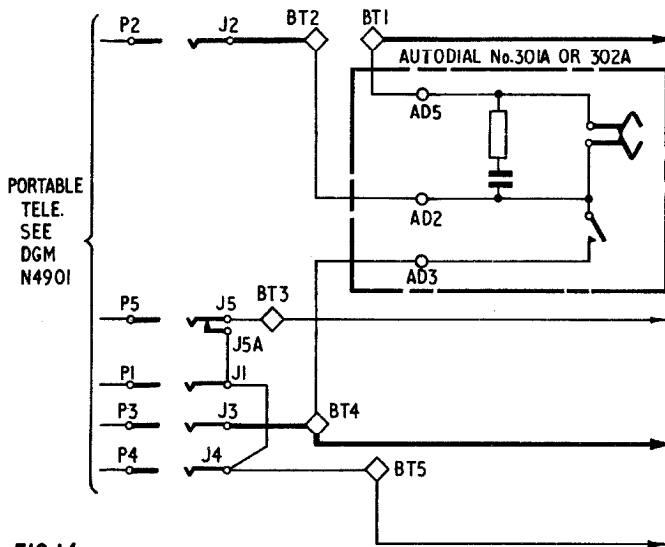

FIG. 14

FIG. 15

FIG. 16

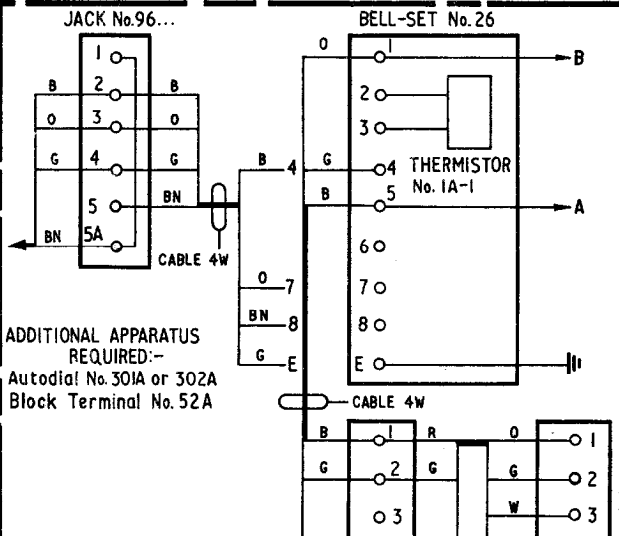
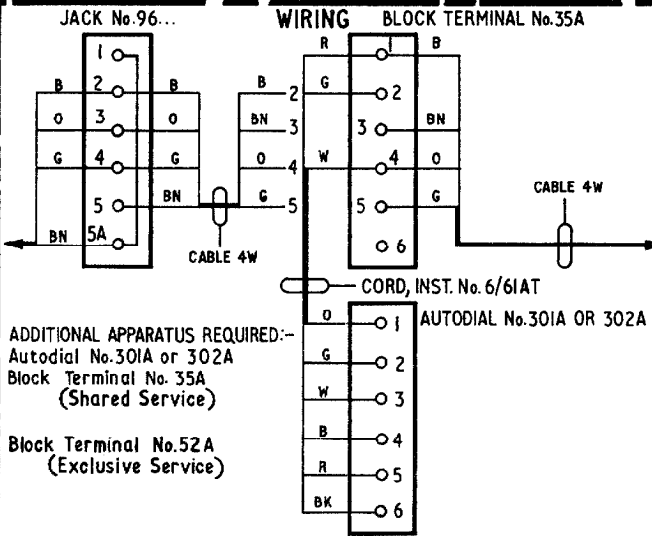
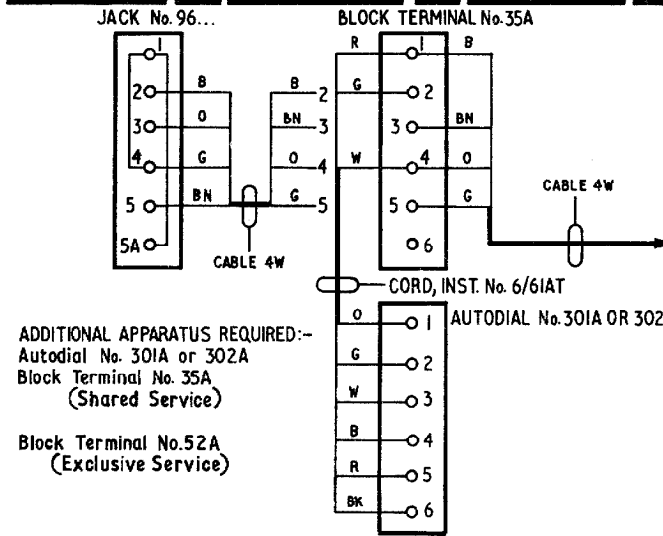

FIG. 17

FIG. 18

FIG. 19

SHARED SERVICE (SEPARATE METERING)
Connexions as shown
EXCLUSIVE SERVICE
Green cable connexions to BT5 and J4 omitted. J3 and J4 strapped

SHARED SERVICE (SEPARATE METERING)
Connexions as shown
EXCLUSIVE SERVICE
Green cable connexions to BT5 and J4 omitted. J3 and J4 strapped

SHARED SERVICE (SEPARATE METERING)
Connexions as shown
EXCLUSIVE SERVICE
Earth and green cable connexions to J4 and E omitted
J3 and J4 strapped. Thermistor No. 1A-1 omitted. B2-B3 omitted