

CIRCULATION	C.B. & AUTO
	Suffix
PAPER	W
Amendt.	

# C.B. & AUTOMATIC SYSTEMS

## SUBSCRIBER'S EXTENSION PLAN 9 (INTERNAL ONLY)

ON P.M.B.X.S WITH 'C' WIRE SIGNALLING, USING TELEPHONE No.710...

N4652

2 PANELS-1  
19-12-61

1. THE FACILITIES OF PLAN 9 ARE SHOWN ON DGM. N1432

### 2. APPARATUS REQUIRED

TELEPHONE No.710...	PART 8/DBU/260
PART 1/DSP/1244	PART 1/DST/836
PART 1/DSP/1245	SWITCH No.5A-4
PART 1/DSP/1242	RESISTOR, COIL No.35A-300 $\Omega$ .
PART 16/DBU/260	CORD, INSTRUMENT No.9/21AD...
PART 14/DBU/260	BLOCK, TERMINAL No.20/B

3. IN THE TELEPHONE No.710... FIT PART 1/DSP/1244 AND PART 16/DBU/260 (ENQ.) IN POSITION A. THE LATCH SHOULD BE AT SETTING 1 (SEE N848 PANEL 4). FIT SWITCH No.5A-4 AND PART 14/DBU/260 (NORM) IN POSITION B. THE LATCH SHOULD BE AT SETTING 2, THE SWITCH 5A-4 IN THIS POSITION ACTS AS A RETAINING UNIT. FIT PART 1/DSP/1245 AND PART 8/DBU/260 (RECALL) IN POSITION D. THE LATCH SHOULD BE AT SETTING 3. X AND Y LATCHES SHOULD BE AT SETTING 4. REARRANGE STRAPS. FIT PART 1/DSP/1242. FIT RESISTOR, COIL No.35A, CORD, INST. No.9/21AD... AND BLOCK, TERMINAL No.20/B. CONNECT AS SHOWN.

4. IF AN EXTENSION BELL IS REQUIRED REMOVE STRAP T16-T19, RECOVER BLOCK, TERMINAL No.20/B, FIT BLOCK, TERMINAL No.31A AND CONNECT BELL TO SL AND GRN-RED CONDUCTORS OF CORD, INST. No.9/21AD...

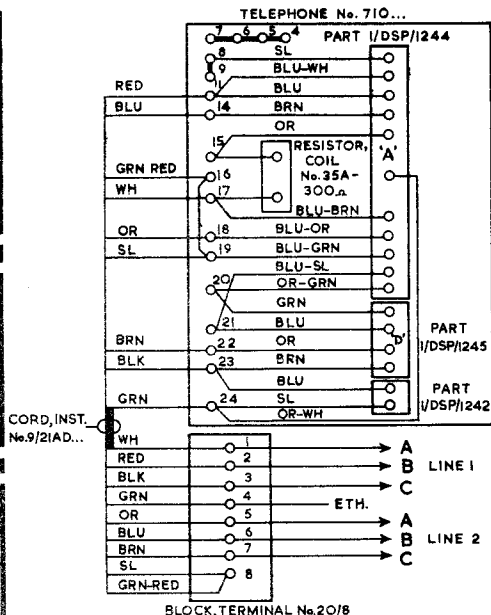

N 4652

2 PANELS 2

TELEPHONE No. 710 ...

