

CIRCULATION
C.B. & AUTO.
Suffix
Amend
PAPER
W

C.B. & AUTOMATIC SYSTEMS

SUBSCRIBER'S EXTENSION PLAN 9 (INTERNAL OR EXTERNAL)

ON 2W P.B.X.S. WITH OR WITHOUT RECALL, USING TELEPHONE No.710...

N4552
2 PANELS - 1
23-11-61

1. THE FACILITIES OF PLAN 9 ARE SHOWN ON DGM.NI432.
2. **APPARATUS REQUIRED**
 TELEPHONE No.710... PART 16/DBU/260
 PART 1/DSP/1244 PART 14/DBU/260
 SWITCH No.5A-4 CORD, INSTRUMENT No.5/37AA
 RESISTOR, COIL No.35A-300Ω BLOCK, TERMINAL No.30
 IF RECALL IS REQUIRED, PROVIDE AN ADDITIONAL SWITCH No.5A-4
 AND PART 8/DBU/260.
3. IN THE TELEPHONE No.710... FIT PART 1/DSP/1244 AND PART 16/DBU/260 (ENQUIRY) IN POSITION A. THE LATCH BRACKET SHOULD BE AT SETTING 1. (SEE N848 PANEL 4). FIT SWITCH No.5A-4 AND PART 14/DBU/260 (NORMAL) IN POSITION B THE SWITCH IN THIS POSITION ACTS AS A RETAINING UNIT, THE LATCH BRACKET SHOULD BE AT SETTING 2. LATCHES X AND Y SHOULD BE AT SETTING 4. REARRANGE STRAPS. FIT RESISTOR, COIL No.35A-300Ω. FIT CORD, INST. No. 5/37AA... AND BLOCK, TERMINAL No.30. IF RECALL IS REQUIRED FIT SWITCH No.5A-4 AND PART 8/DBU/260 IN POSITION D, THE LATCH BRACKET SHOULD BE AT SETTING 3. FIT STRAP T8-T9 AS REQUIRED
4. IF AN EXTENSION BELL IS REQUIRED, RECOVER CORD, INSTRUMENT No.5/37AA... AND BLOCK, TERMINAL No.30, PROVIDE CORD, INSTRUMENT No.9/21AD... AND BLOCK, TERMINAL No.20/8. REMOVE STRAP T16-T19 CONNECT ADDITIONAL BLACK AND BROWN CONDUCTORS TO T16 AND BT6, AND T19 AND BT7 CONNECT BELL TO BT6 AND BT7.

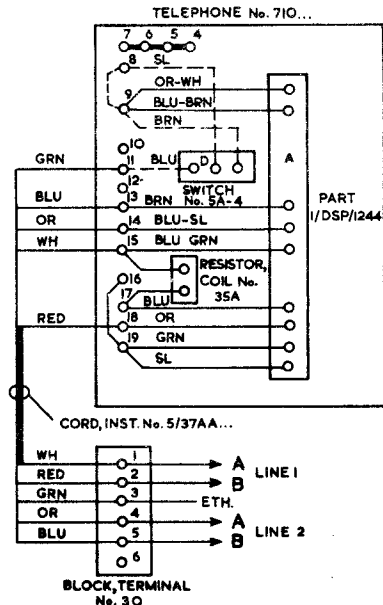

N4552

2 PANELS-2

TELEPHONE No. 710...

