

N4538

4 PANELS-1

1-5-63

# AUTOMATIC SYSTEM

SHARED SERVICE (SEPARATE METERING)

EXTENSION PLAN IA (INTERNAL ONLY)

ON INTERNAL EXTENSIONS OF PLANS 105, 105A, 107 AND 107A

## NOTES :-

1. THIS DIAGRAM SHOULD BE USED IN CONJUNCTION WITH DIAGRAMS N4527 AND N4529.
2. **INTERNAL EXTENSION PLAN 107**  
 APPARATUS REQUIRED FOR EXTENSION PLAN IA.  
 TELEPHONE No. 710...  
 2 SWITCHES No. 5A-4  
 PART 1/DSP/1243  
 PARTS 2/DBU/260, 4/DBU/260 & 3/DBU/262  
 PART 1/DST/836  
 BUZZER No. 32A-1  
 CORD INSTRUMENT No. 9/21AD...  
 2 BLOCKS TERMINAL No. 35A.
3. REARRANGE STRAPS OF THE TELEPHONE No. 710. FIT SWITCHES No. 5A-4 INTO POSITIONS A & D. FIT PART 1/DSP/1243 INTO POSITION C. FIT PARTS 4/DBU/260 (MAIN) 3/DBU/262 (BELL OFF) AND 2/DBU/260 (EXCH.) IN POSITIONS A,C & D RESPECTIVELY. LATCHES A,C & D SHOULD BE AT SETTING 3. LATCHES X & Y AT SETTING 5 (SEE N848). FIT BUZZER No. 32A-1. FIT CORD INST. No. 9/21AD AND BLOCK TERMINAL No. 35A.
4. AT PLAN 107 EXTENSION RECOVER BLOCK TERMINAL No. 30. FIT BLOCK TERMINAL No. 35A, CONNECT CORD INST. AS SHOWN ON PANEL 4. THE CONNEXIONS IN THE TELEPHONE AT THIS STATION ARE AS SHOWN ON DIAGRAM N4529 AND DO NOT REQUIRE ALTERATION.
5. AN EXTENSION BELL MAY BE CONNECTED IN PLACE OF STRAP BT7-BT8 AT EITHER STATION.
6. **INTERNAL EXTENSION PLAN 105**  
 APPARATUS REQUIRED FOR EXTENSION PLAN IA  
 AS IN NOTE 2. WITH AN ADDITIONAL SWITCH No. 5A-4 AND PART 3/DBU/260. BLOCK TERMINAL No. 36A.
7. SWITCHES AND PARTS ARE FITTED INTO THE TELE. No. 710. AS IN NOTE 3. THE ADDITIONAL SWITCH No. 5A-4 AND PART 3/DBU/260 (EXTN.) ARE FITTED

- IN POSITION B. WITH LATCH AT SETTING 3. REARRANGE STRAPS. FIT CORD INST. No. 9/21AD AND BLOCK TERMINAL No. 36A.
8. THIS DIAGRAM SHOWS EXTENSION PLAN IA ON EXTENSION 1 OF A PLAN 105. AT THIS EXTENSION THE STRAP BT2-BT5 SHOULD BE REMOVED, THE CONNEXION FROM THE BELL AT EXTN. 2 SHOULD BE TRANSFERRED FROM BT10 TO BT11 AND STRAP BT10-BT11 INSERTED.  
 WHEN THE EXTENSION PLAN IA IS REQUIRED ON EXTN. 2 OF A PLAN 105 THE CONNEXIONS AT THE PLAN IA ARE AS SHOWN ON THIS DIAGRAM BUT WITH THE BLU AND BRN CORD CONDUCTORS REVERSED AT BT3 AND BT9. EXTENSION 2 OF THE PLAN 105 IS CONNECTED AS SHOWN ON N4527 WITH STRAP BT2-BT5 REMOVED.
9. AN EXTENSION BELL MAY BE CONNECTED IN PLACE OF STRAP BT10-BT11 AT EITHER STATION.

CIRCULATION	CB & AUTO
Suffix	
Amend	
PAPER	W

# N 4538

4 PANELS-2

## PLAN IO7 INTERNAL EXTN.

## PLAN IA EXTN.

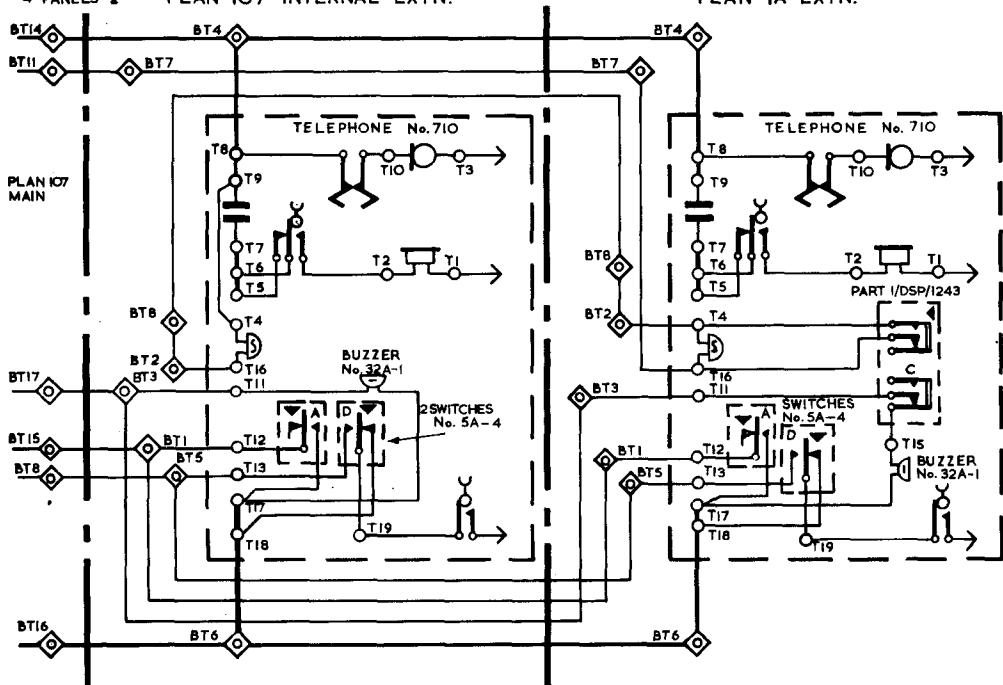

CIRCULATION	C B & AUTO
	Suffix
Amendt	
PAPER	W

PLAN 105 INTERNAL EXTN. 1

PLAN 1A EXTN.

N4538

4 PANELS-3  
1-5-63.

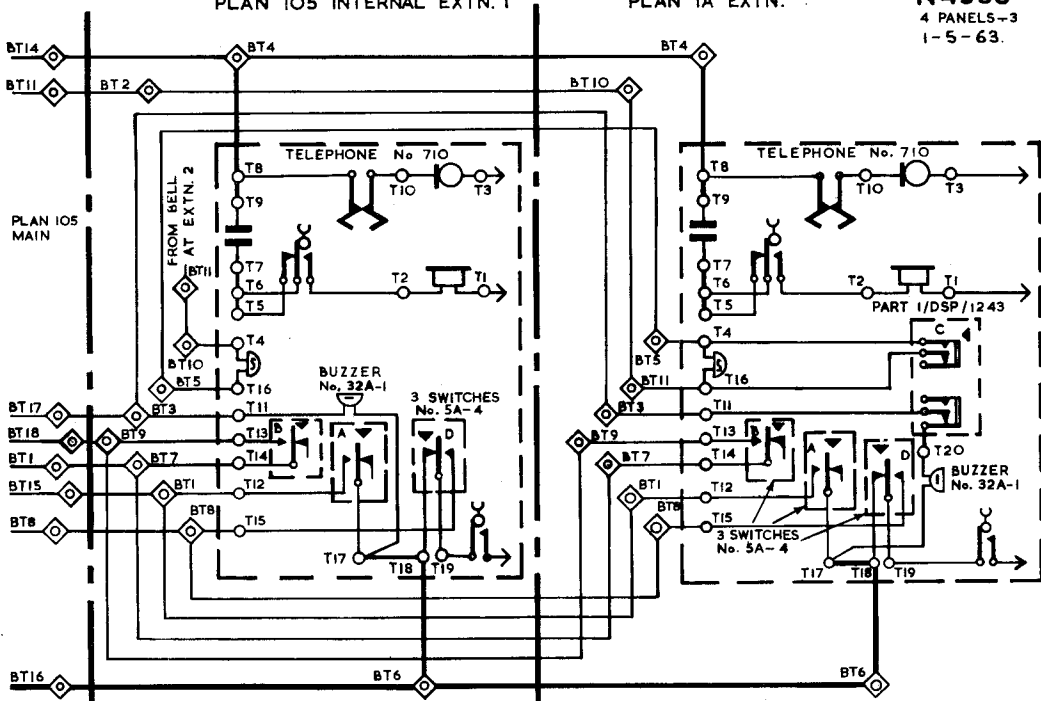

# N4538 EXTN. PLAN 1A ON EXTN. OF PLAN 107

4 PANELS-4

EXTN. PLAN 1A.  
TELEPHONE No. 710...

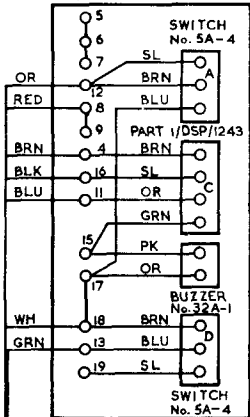

CORD INST. No. 9/21AD.

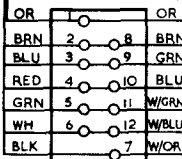

BLOCK TERMINAL  
No. 35A

CABLE 8W

PLAN 107 EXTN.  
TELEPHONE No. 710...

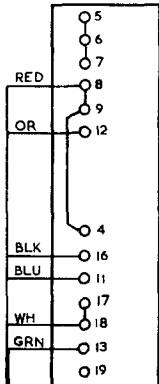

CORD INST. No. 6/44 AA...

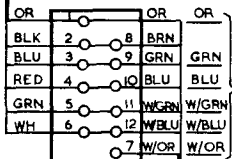

BLOCK TERMINAL No. 36A

TO MAIN

# EXTN. PLAN 1A ON EXTN. OF PLAN 105

EXTN. PLAN 1A.  
TELEPHONE No. 710...

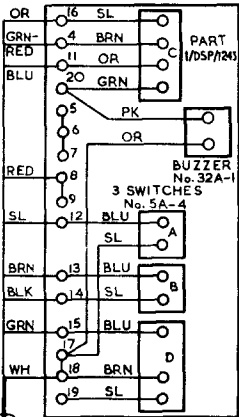

CORD INST. No. 9/21AD...

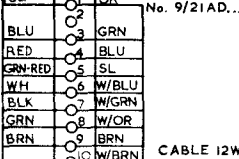

BLOCK TERMINAL No. 36A

CABLE 12W

PLAN 105 EXTN. 1.  
TELEPHONE No. 710...

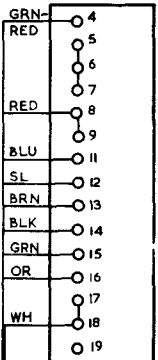

CORD INST. No. 9/21AD.

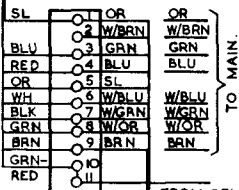

BLOCK TERMINAL No. 36A

FROM BELL  
AT EXTN. 2

TO MAIN