

N4535

2 PANELS-2

PLAN 1 EXTENSION.

TELEPHONE No. 706...

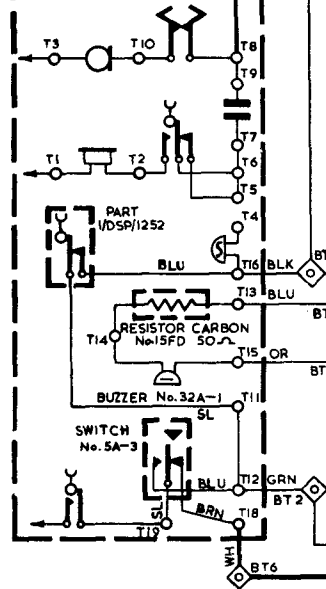

PLAN 107 MAIN

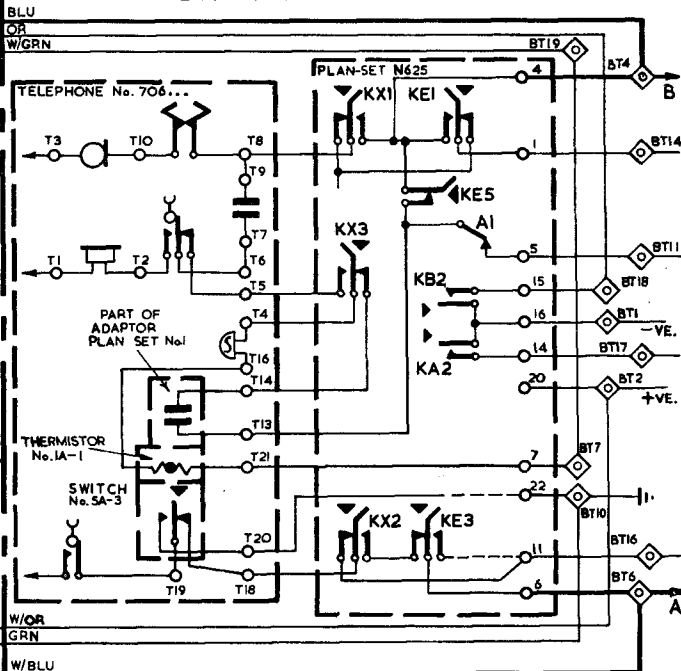

BLU
OR
W/GRN

W/OR
GRN

W/BLU

PLAN-SET N625

TELEPHONE No. 706...

PART OF
ADAPTOR
PLAN SET No. 1

THERMISTOR
No. 1A-1

SWITCH
No. 5A-3

KX1 KE1

KX3

KA2

KX2 KE3

KE5

A1

KB2

KA2

BT19

BT4

B

BT14

BT11

BT18

BT1

-VE.

BT17

BT2

+VE.

BT7

BT10

BT16

BT6

A