

C.B. & AUTOMATIC SYSTEMS
EXTENSION WORKING, PLAN Nos. 12 & 12A (INTERNAL ONLY)

N4316
 4 PANELS-1
 7-3-41

C.B. & AUTO

3.5.63/C
 12.3.62 B
 26.5.61 A

NOTE 1 AMENDED TO SHOW SUPERSESSION
 ALL PANELS MADE YELLOW
 MODIFICATIONS TO KEY No. 303A & BELL No. 56A
 REDRAWN. NOTES REVISED.

Y

APPARATUS SCHEDULE

PLAN No. 12

MAIN	EXTENSION
1 TELEPHONE No. 328... 1 CORD INST. No. 6/21B..." 1 KEY No. 303A 1 LABEL No. 252 D 1 BLOCK TERMINAL No. 20/8 2 PARTS No. 1/SPL/325	1 TELEPHONE No. 332... 1 CORD INST. No. 4/57B..." 1 BLOCK TERMINAL No. 20/8

PLAN No. 12A

MAIN	EXTENSION
1 TELEPHONE No. 328... 1 CORD, INST. No. 8/06B..." 1 KEY No. 303A 1 LABEL No. 252 P 1 BLOCK, TERMINAL No. 20/8 1 SWITCH, TUMBLER No. 1M (IF REQUIRED) 1 BELL No. 56A 3 PARTS No. 1/SPL/325 1 RECTIFIER ELEMENT No. 205	1 TELEPHONE No. 328... 1 CORD, INST. No. 5/14 B..." 1 BLOCK, TERMINAL No. 20/8 1 BELL No. 56A 3 CELLS, DRY R40 AND 1 BOX, BATTERY No. 3 1 KEY No. 302A-1 1 PART No. 1/SPL/325 1 LABEL No. 252 E 1 RECTIFIER ELEMENT No. 205

N4316

4 PANELS- 2

NOTES:-

GENERAL

1. THE FACILITIES OF PLAN 12 ARE SHOWN ON DGM.N1437 AND OF PLAN 12A ON DGM.N1438. FOR NEW WORK PLAN 12A WITH 700 TYPE TELEPHONES SHOULD BE PROVIDED.
2. WHEN PLAN No. 12A, I.E. ADDITIONAL BOTHWAY TREMBLER BELL WORKING FACILITY IS REQUIRED, CONNECT UP ADDITIONAL APPARATUS AS SHOWN THUS — X — X — SWITCH TUMBLER No. 1M MAY BE FITTED OPTIONALLY ON PLAN 12A ONLY, TO CUT OFF THE MAGNETO BELL AT THE MAIN, WHEN REQUIRED.

MAIN

3. SET KEY No. 303A CONTROL PLATE IN ACCORDANCE WITH FIG. 3 DIAGRAM N4301.
AUTOMATIC GRAVITY SWITCH RESTORATION OF CIRCUIT TO "NORMAL" MUST BE PROVIDED. TRANSFER EXTENSION ARM NORMALLY FITTED ON THE SIDE OF THE KEY No. 303A CHASSIS TO THE APPROPRIATE POSITION ON THE GRAVITY SWITCH.
FIT KEY PLUNGERS IN POSITIONS A & C FOR PLAN 12 AND IN POSITIONS A, B & C FOR PLAN 12A.

EXTENSIONS

4. STRAP T1-T2 AND REMOVE STRAPS T10-T11-T12. PLAN 12A. FIT KEY IN POSITION B AND SET LATCH TO NON LOCK.
5. WHEN EXTENSION BELL IS REQUIRED, CONNECT IN PLACE OF STRAP BETWEEN TERMINALS BT4 AND BT5 ON BLOCK TERMINAL No. 20/8 AT EXTENSION.
6. COILS OF BELLS No. 56A SHOULD BE CONNECTED IN PARALLEL
7. RECTIFIER ELEMENTS No. 205 SHOULD BE CONNECTED TO THE RECEIVER TERMINALS OF HANDSETS AT BOTH STATIONS

WIRING DIAGRAM

NOTE 1 AMENDED TO SHOW SUPERSESSION
 ALL PANELS MADE YELLOW
 MODIFICATIONS TO KEY No. 303A & BELL No. 56A
 REDRAWN NOTES REVISED.

3.5.63. C
 12.3.62 B
 26.9.61 A

Y

EXTENSION

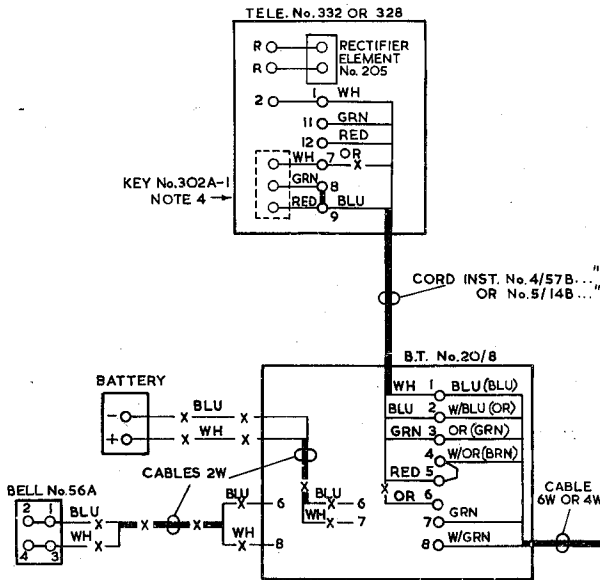

MAIN

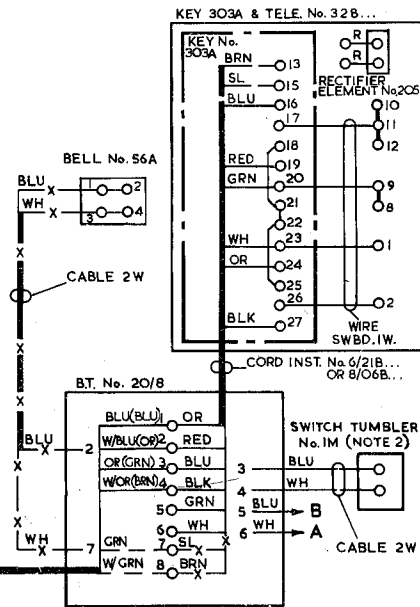

N 4316

4 PANELS-4

EXTENSION
TELEPHONE No. 328...

MAIN
TELEPHONE No. 328...

