

N 4200

2 PANELS - 1

TELEPHONE No. 150.... & BELL SET No. 1 OR 25.

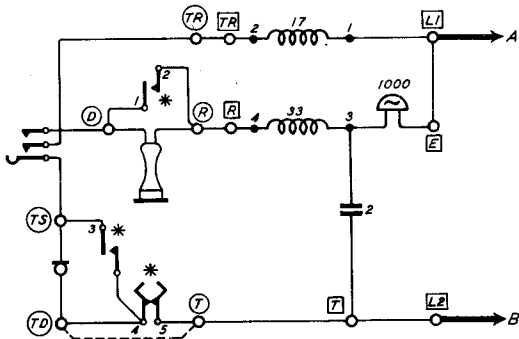

EXPLANATORY

TELEPHONE No. 162.... 1/162.... & BELL SET No. 1 OR 25.

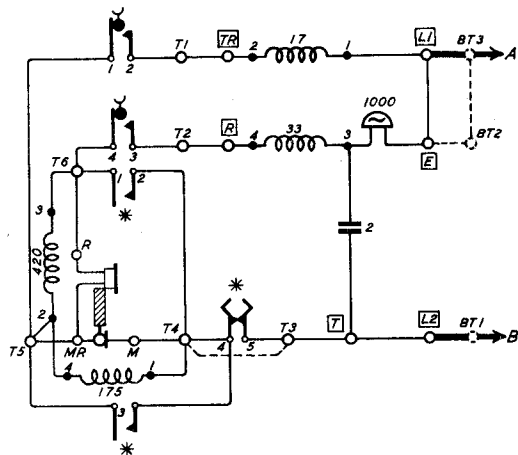

* DIAL CONTACTS.

TERMINAL POINTS.

□	BELL SET
BT	BLOCK TERMINAL
T	TELES. No. 162... 1/162....
○	TELE. No. 150....

TERMINALS T3 & T4 (TELE No. 162.... 1/162....) & TERMINALS T & TD (TELE. No. 150....) ARE STRAPPED FOR C.B. WORKING AND THE DIAL OMITTED.