

AUTODIAL No 105A
46 ADDRESS, PRESS-BUTTON REPERTORY DIALLER WITH MF SIGNALLING

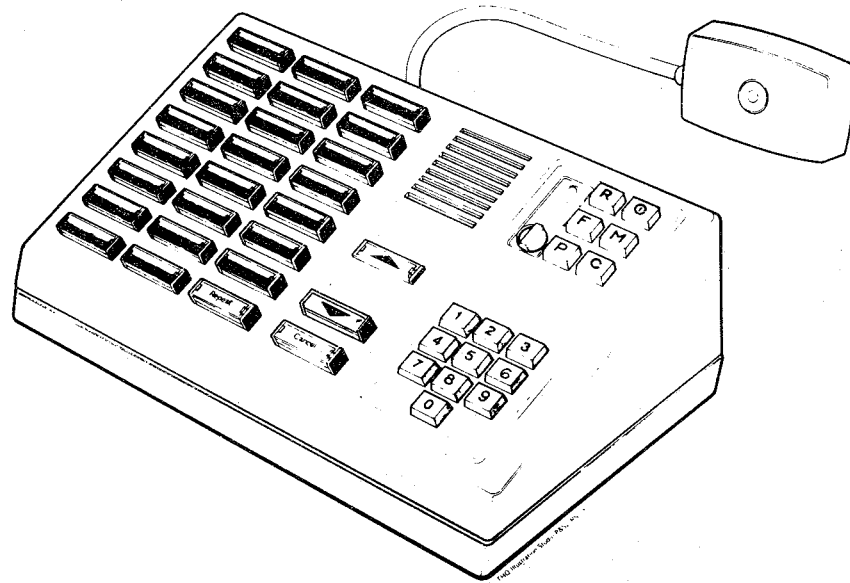

CONNEXIONS

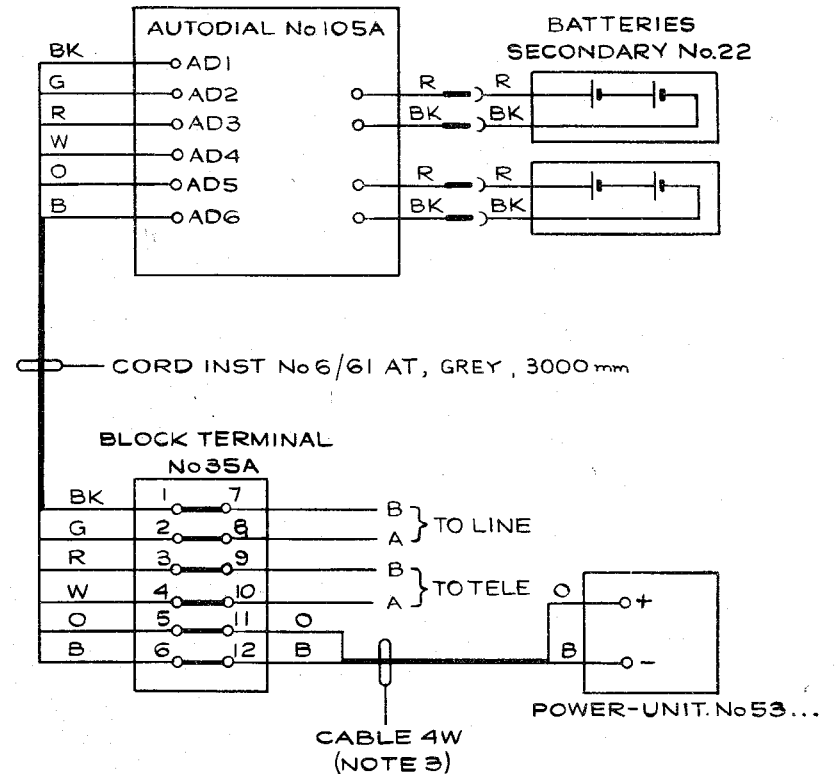

REFERENCES :-

FACILITIES	TI B4 M0057
INSTALLATION	TI C3 S0105
MAINTENANCE	TI E5 F3215
POWER UNIT No.53...	DGM N631

NOTES :-

1. APPARATUS TO BE REQUISITIONED SEPARATELY :
2 BATTERIES SECONDARY No.22
POWER-UNIT No.53
2. THE POWER-UNIT No.53 SHOULD BE FITTED ADJACENT TO A 3 PIN MAINS SOCKET IN ACCORDANCE WITH DIAGRAM N631.
3. THE LENGTH OF CABLE BETWEEN THE POWER-UNIT AND THE BT OF THE AUTODIAL SHOULD NOT EXCEED 25M.
4. FIT BOTH BATTERIES SECONDARY No.22 IN THE COMPARTMENT BENEATH THE AUTODIAL AND CONNECT TO THE 2 PIN PLUGS PROVIDED.

TAKE CARE NOT TO DAMAGE ANY WIRES WHEN REPLACING THE COVER TO THE BATTERY COMPARTMENT.

5. SINGLE LINE INSTALLATIONS
CONNECT THE INCOMING LINE DIRECTLY TO AUTODIAL TERMINALS AD1, AD2. ALL TELEPHONES AND EXTENSION BELLS SHOULD BE CONNECTED BEHIND THE AUTODIAL TO TERMINALS AD3, AD4.
6. MULTI-LINE INSTALLATIONS
THE AUTODIAL CAN ONLY BE CONNECTED TO ONE SELECTED EXCHANGE LINE AND SHOULD BE WIRED IN ACCORDANCE WITH NOTE 5.
7. NO ATTEMPT SHOULD BE MADE TO OPEN THE AUTODIAL. THE ONLY FIELD REPLACEABLE PARTS ARE :-

BATTERIES SECONDARY No.22
CORD INST No.6/61 AT, GREY, 3000 mm
BLOCK TERMINAL No. 35A

PO TELECOMMS HQRS	ISSUE		
PAPER :-W			
DISTN :-		A MADE WHITE. ✓ <i>Qud. 403</i>	27-6-79
GENERAL		B <i>403. 1/10</i>	TD7-1-3 11-10-77