

CONTENTS	ITEM No.
TYPICAL INSTALLATION	1
STORES	2
INSTALLATION - GENERAL NOTES	3 - 12
DISTRIBUTION	13
PROVISION OF EXCHANGE LINES	14 - 18
PROVISION OF EXTENSION LINES	19 - 21
PROVISION OF INTER-PBX LINES	22
POWER SUPPLIES	23 - 26
CABLING	27
SWITCHBOARD STRIP CONNEXION LAYOUT	28

REFERENCES

DESCRIPTION OF SWBD	ET. TELES PBX
LIST OF MAIN COMPONENTS	N. 2233
EXPLANATORY DIAGRAMS	N. 2233
DIAGRAM NOTES	SA 7601 (COVERS SA 7601-9)
DIAGRAMS:- POSITION	SA 7601 SAW 76010
CORD CIRCUIT	SA 7602 SAW 76020
EXCH LINES	SA 7603 SAW 76030
OPERATOR & MISC	SA 7604 SAW 76040
ENGAGED TEST	SA 7605 SAW 76050
AUDIBLE CLEAR	SA 7606 SAW 76060
EXTN UNITS 1 & 2	SA 7607 SAW 76070
EXTN UNITS 3 & 4	SA 7608 SAW 76080
SIDE TONE SUPPRESSION	SA 7609 SAW 76090
CONVERTER RINGING NO 11A	N. 682
CONVERTER RINGING NO 12A	N. 683
POWER UNIT NO 77A	N. 684
78A	N. 685
RECTIFIER NO 61B	N. 661
61C	N. 661
61D	N. 661
FUSE UNIT NO 2A	N. 675
EXCHANGE LINE EQUIPMENT (MOUNTED EXTERNAL TO SWBDS)	SA 7616 SAW 76160
EXTENSION TELEPHONES	N. 806
METERING	N. 2250
DISTRIBUTION TYPICAL ARRANGEMENTS	SD. 136
FACE EQUIPMENT LAYOUT	ES. 6283

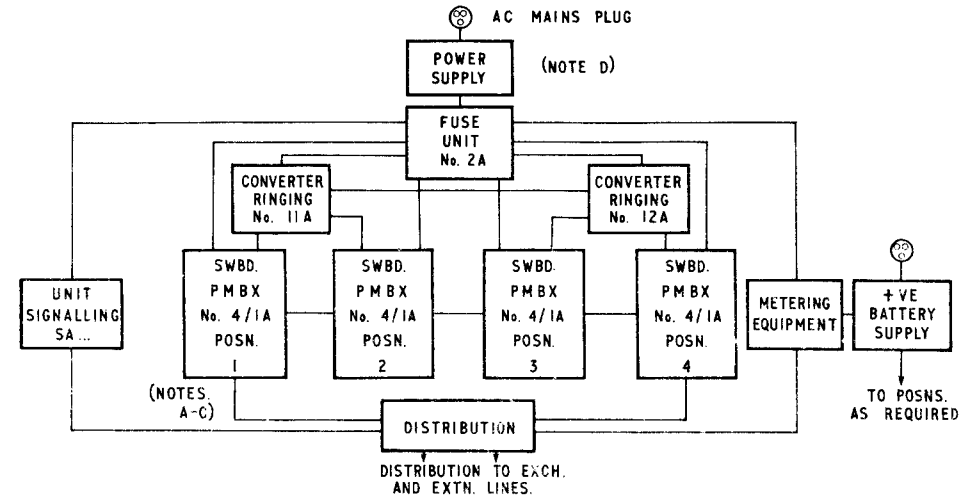

FIG. 1

I. TYPICAL INSTALLATION AND INFORMATIVE NOTES

A. SWITCHBOARD

SWBD. PMBX NO. 4/1A IS WIRED AND EQUIPPED FOR 40 EXTENSIONS; WIRED FOR 20 EXCHANGE LINES WITH FACE EQUIPMENT FOR 10 AND WIRED FOR 10 INTERSWBD. CTS WITH FACE EQUIPMENT FOR 5. THE OPERATOR'S AND MISCELLANEOUS CIRCUITS RELAY SET SA 7604 (WHICH INCLUDES THE SIDETONE SUPPRESSION UNIT SA 7609) AND CORD CIRCUIT RELAY SETS ARE NOT SUPPLIED WITH THE SWITCHBOARD AND MUST BE REQUISITIONED SEPARATELY. NORMALLY 10 CORD CIRCUITS ARE STANDARD PROVISION AND 10 PAIRS OF CORDS ARE SUPPLIED FITTED TO THE SWITCHBOARD. WHEN 11-15 CORD CIRCUITS ARE AUTHORISED ADDITIONAL CORDS AND PULLEY WEIGHTS ARE REQUIRED. THE KEYS FOR CORD CIRCUITS 11-15 ARE BELOW THE KEY SHELF AND WIRED READY FOR RAISING INTO POSITION WHEN THESE CIRCUITS ARE EQUIPPED. CABLING INTO THE SWITCHBOARD IS VIA THE ENTRY SLOTS IN THE SIDES OR REAR OR DIRECTLY UNDERNEATH.

B. EXCHANGE LINES

EXCHANGE LINE RELAY SETS ARE PROVIDED AS REQUIRED, FOR DETAILS OF METHOD OF PROVISION SEE ITEM 14. EQUIPMENT FOR 12 EXCHANGE LINES CAN BE ACCOMMODATED WITHIN EACH SWBD. WHEN MORE THAN 24 OR 36 EXCHANGE LINES ARE REQUIRED FOR 2 OR 3 POSN. INSTALLATIONS, UNITS SIGNALLING SA 7616 ARE ADDED AND MOUNTED EXTERNAL TO THE SWITCHBOARD. THE NORMAL MAXIMUM NUMBER OF EXCHANGE LINES FOR FOUR POSNS IS 40.

C. EXTENSION LINES

ALL EXTENSION CIRCUITS ARE 2- WIRE PLUS AN EARTH FOR RECALL PURPOSES. ALTHOUGH THE SWITCHBOARD IS EQUIPPED FOR 40 EXTENSIONS, THE MAXIMUM NUMBER OF EXTN. ANSWERING EQUIPMENTS THAT CAN BE PROVIDED IN ANY MULTIPLE POSITION IS 80, BUT IS NORMALLY LIMITED TO 50 OR 60. SEE DRG. ES. 6233. THE CAPACITY IS INCREASED BY REQUISITIONING PMBX NO. 4 EXTN. UNITS NO. 1 OR 2., EACH UNIT Caters FOR 10 ANSWERING EQUIPMENTS, PMBX NO. 4 EXTN. UNITS NOS. 3 AND 4 PROVIDE THE MULTIPLE JACKS., EACH UNIT Caters FOR 20 MULTIPLE EQUIPMENTS.

D. POWER PLANT

THE TYPE OF POWER PLANT TO BE PROVIDED WILL DEPEND ON WHETHER THE INSTALLATION IS TO BE OPERATED FROM A POWER UNIT OR A DEDICATED BATTERY AND THE OUTPUT REQUIRED. FOR DETAILS SEE ITEMS 23-26.

P.O.T.D.D. TD. I.5.2	ISSUES		
PAPER : Y			
CIRCULATION GENERAL	A	SUPERSEDED FOR NEW WORK BY SPECIFICATION S1156, MADE YELLOW. <i>MWH</i>	4.1.1972
		<i>DEJ</i>	8-3-68

2. STORES REQUIRED.

TABLE I.

APPARATUS	QUANTITY	REMARKS
<b>SWITCHBOARDS.</b>		
SWITCHBOARD PMBX NO. 4/1A	AS REQUIRED	OPERATOR'S RELAY SET OPERATOR'S TELEPHONE INSTRUMENT
RELAY SET SA 7604	1 PER POSN.	
HEADSET NO. 1 GREY	1 PER POSN.	
PLUG NO. 420 GRAY WITH CORD NO. 4/77AB	1 PER POSN.	
LABEL NO. 461C	1 PER POSN.	
LABEL NO. 461E	1 PER POSN.	L.H.S. STILE BAR LABEL CENTRE STILE BAR LABEL
<b>CORD CIRCUITS.</b>		
RELAY SETS NO. 1/SA 7602	5 PER POSN.	FOR STANDARD PROVISION OF 10 CORD CIRCUITS PER POSN. (2 PER BASE.)
RELAY SETS NO. 1/SA 7602	AS REQUIRED	2 PER BASE FOR ADDITIONAL CORD CIRCUITS IN EXCESS OF
RELAY SETS NO. 2/SA 7602	AS REQUIRED	1 PER BASE 10 PER POSN. IF AUTHORIZED ON A.N
CORDS SWITCHBOARD NO. 391 GREEN	2 OR 4 PER POSN.	FOR CORD CIRCUITS 11 AND 15 ON ANY POSN. (2 PER CIRCUIT)
CORDS SWITCHBOARD NO. 391 BLUE	AS REQUIRED	FOR CORD CIRCUIT 12 ON ANY POSN. (2 PER CIRCUIT)
CORDS SWITCHBOARD NO. 391 YELLOW	2 PER POSN.	FOR CORD CIRCUIT 13 ON ANY POSN. (2 PER CIRCUIT)
CORDS SWITCHBOARD NO. 391 BLACK	AS REQUIRED	FOR CORD CIRCUIT 14 ON ANY POSN. (2 PER CIRCUIT)
PLUGS SWBD. NO. 321 GREY	AS REQUIRED	FOR CORD CIRCUITS 11-15 ON ANY POSN. (2 PER CIRCUIT)
WEIGHTS PULLEY NO. 19A, 60Z	AS REQUIRED	FOR CORD CIRCUITS 11-15 ON ANY POSN. (2 PER CIRCUIT)
LAMPS №2 45V	AS REQUIRED	FOR CORD CIRCUITS 11-15 ON ANY POSN. (2 PER CIRCUIT)
<b>EXCHANGE LINES.</b>		
RELAY SETS NO. 1/SA 7603	AS REQUIRED	3 PER BASE FOR 2 TO 10 EXCHANGE LINES
RELAY SETS NO. 2/SA 7603	AS REQUIRED	2 PER BASE IN ANY POSN., SEE ITEM 14 FOR PROVISION
UNITS SIGNALLING SA 7616	AS REQUIRED	FOR ADDITIONAL EXCHANGE LINE CCTS. MOUNTED EXTERNAL TO SWITCHBOARDS. TO BE ENGRAVED WITH EXCHANGE LINE NUMBER. SEE DRG. E.S. 6283
CAPS LAMP NO. 76A OPAL	1 PER EXCHANGE LINE APPEARANCE	FOR EXCHANGE LINES 11-40 ON ANY POSITION (SEE ITEM 7)
JACK NO. 710 BR	1 PER 10 EXCHANGE LINES PER POSN. AS REQUIRED	
JACK LAMP NO. 61/20	1 PER 10 EXCHANGE LINES PER POSN. AS REQUIRED	
COVER LAMP NO. 8/20	1 PER 10 EXCHANGE LINES PER POSN. AS REQUIRED	
CAPS LAMP NO. 76A OPAL	1 PER APPEARANCE AS REQUIRED	
STRIP CONNEXION NO. 156/9A	1 PER POSN.	WHEN CIRCUITS 21-40 ARE PROVIDED
CAPS LAMP NO. 76A LIGHT GREY	AS REQUIRED	DUMMIES FOR SPARE EXCHANGE LINE LAMP JACKS AND FLS LAMP JACKS IF FLS NOT PROVIDED
CAPS LAMP NO. 76B	1 PER APPEARANCE AS REQUIRED	ARROWED LAMP CAP FOR FLS INDICATION WHEN REQUIRED
LAMPS NO. 2 45V	AS REQUIRED	FOR FLS AND EXCH. LINES 11-40
<b>EXTENSIONS.</b>		
TELEPHONES NO. 706... COLOUR	1	PER EXTN. LINE
PART NO. 3/DBU/283 AND SWITCH 5 A-3	1 AND 1	
PMBX NO. 4 EXTN UNITS NO. 1	AS REQUIRED	10 EXTN. CCTS PER UNIT L.H. PANELS FOR CCTS 40-49, 60-69
PMBX NO. 4 EXTN. UNITS NO. 2	AS REQUIRED	10 EXTN. CCTS PER UNIT R.H. PANELS FOR CCTS 50-59, 70-79
LAMPS NO. 2 45V	AS REQUIRED	1 PER CCT FOR ADDITIONAL EXTNS.
KITS NO. 133/4-19	AS REQUIRED	CAPS LAMPS NO. 76A OPAL ENGRAVED IN KITS OF TEN (EG. NO. 133/7 ENGRAVED 70-79)

TABLE I. CONTD.

APPARATUS	QUANTITY	REMARKS
STRIPS SPACING NO. 6A - 6E	AS REQUIRED	1"-2 1/2" AS APPLICABLE SEE ES 6283 (EG NO. 6C IS 1 1/2")
PMBX NO. 4 EXTN. UNITS NO. 3	AS REQUIRED	1 PER 20 EXTN MULTIPLE JACKS IN L.H. PANELS OF ALL POSNS.
PMBX NO. 4 EXTN. UNITS NO. 4	AS REQUIRED	1 PER 20 EXTN. MULTIPLE JACKS IN R.H. PANELS OF ALL POSNS.
STRIPS CONNEXION NO. 191/6A	AS REQUIRED	EXTN. CONCENTRATOR BLOCK 1 PER 30 EXTNS EXCLUDING EXTENSIONS ON LAST POSN
UNITS SIGNALLING SA7611	AS REQUIRED	1 PER 10 CCTS. REQUIRING LONG LINE CALLING OR DUPLICATE CALLING APPEARANCE. SEE ITEM 6.
<b>RINGING SUPPLY.</b>		
CONVERTER RINGING NO. 11A	1	RINGING GENERATOR FOR POSNS. 1 AND 2
CONVERTER RINGING NO. 12A	1 AS REQUIRED	
<b>METERING.</b>		
SEE DGN. N. 2250		
<b>POWER SUPPLY.</b>		
FUSE UNIT NO. 2A	1	POWER DISTRIBUTION. SEE ITEM 26 FOR FUSE REQUIREMENT
POWER UNIT NO. 77A OR POWER UNIT NO. 78A	1 AS REQUIRED	INSTALLATIONS ENERGIZED FROM MAINS POWER UNIT.
BATTERY SECONDARY NO. 16	2 PER POSN. AS REQUIRED	(SEE ITEM 23 AND ITEM 24)
RECTIFIER NO. 61.....	1 AS REQUIRED	INSTALLATIONS ENERGIZED FROM FLOATED BATTERY (SEE ITEMS 23 AND 25)
CELLS SECONDARY NO. 21/... OR CELLS SECONDARY NO. 22/...	24 AS REQUIRED	
<b>DISTRIBUTION.</b>		
MOUNTING D 92221	1 OR MORE	SEE DRG. SD 136 AND ITEM 9.
PLINTH D 92370	1 OR MORE	
JACKS TEST NO. 33/1A	AS REQUIRED	50 CCTS PER JACK TEST
STRIPS FANNING NO. 4	1 PER JACK TEST NO. 33/1A	
BRACKET MFG. G.A.	2 PER JACK TEST	
STRIPS CONNEXION NO. 150/4A, 150/6A 150/8A, OR 150/10A	AS REQUIRED	80, 120, 160 OR 200 WAY TAG BLOCKS TO TERMINATE CABLES IN MOUNTING D 92221 SEE ITEM 9
FUSE MOUNTING NO. 8064B.	AS REQUIRED	40 CCTS. PER F.M. FITTED AS NECESSARY WHEN EXTERNAL CCTS. ARE
OR FUSE MOUNTING NO. 1064A	AS REQUIRED	5 CCTS PER F.M. PROVIDED (SEE SD 136 AND ITEM 9)
PART 1/DMO/119	AS REQUIRED	1 PER 3 FUSE MOUNTINGS NO 1064A
FUSES NO. 64/02	AS REQUIRED	2 PER CCT.
<b>CABLE AND WIRE.</b>		
CABLE PVC NO. 3A... /6 1/2 LB	AS REQUIRED	INTER POSN. CABLING
CABLE PVC NO 1. 41W/6 1/2	AS REQUIRED	EXTN. CCTS. SWBD. TO DISTN. INTER SWBD. CCTS. SWBD. TO DISTN.
	31W/6 1/2	INTER POSN. TIE CABLES (E/L R/SETS TO E/L JACKS)
	21W/6 1/2	E/L CCTS SWBD. TO DISTN.
	8W/6 1/2	CR 11A TO CR 12A
	6W/6 1/2	CR 11A AND CR 12A TO POSNS.
	4W/6 1/2	POWER SUPPLIES TO CR 11A, CR 12A, U/S SA....
	2W/6 1/2	FUSE ALARM. FUSE UNIT TO POSN. 1
CABLE PVC 250V... 50 IN.	AS REQUIRED	POWER DISTN. SEE ITEMS 24 AND 25
WIRE PVC NO. 1 1W, 2W, 3W, AND 5W/6 1/2	AS REQUIRED	JUMPERING IN SWBD. AND DISTN.
WIRE COPPER SOFT 3/20	AS REQUIRED	EARTHING. SEE ITEM 27
<b>CONNECTOR-R/S TESTING.</b>		
CONNECTOR NO. 1032A	2	FOR R/S MAINTENANCE 2 PER INSTALLATION TO PERMIT R/S TO OPERATE WHEN JACKED OFF OF SWBD.
<b>INTER-SWBD. LINES.</b>		
UNIT SIG. SA...	AS REQUIRED	SEE RELEVANT N DIAG.
PART NO. 2/DJA/18	1 PER APPEARANCE AS REQUIRED	FOR CIRCUITS 6-10 ON ALL POSNS.
PART NO. 1/DJA/13		
CAPS. LAMP NO. 76A OPAL	1 OF EACH PER PART	
LAMPS NO. 2 45V	No. 2/DJA/18	

APPARATUS	QUANTITY	REMARKS
<b>AUDIBLE CLEAR.</b> SUB-UNIT SA 7606 RELAY 16790	1 PER POSN. AS REQUIRED 1 PER SA 7606	WHEN AUTHORISED ON A/N SEE ITEM 11
<b>ENGAGED TEST.</b> SUB-UNIT SA 7605	1 PER POSN.	SEE ITEM 12
<b>TRANSMITTER CUT OUT.</b> SWITCH NO. 5A	1 PER POSN. AS REQUIRED	WHEN AUTHORISED ON A/N
<b>WHERE NO DIALLING REQD.</b> PLATE MOUNTING NO. 5A	1 PER POSN. AS REQUIRED	TO REPLACE DIAL MOUNTING AND PLATE MTG. NO. 5B FITTED.
<b>SPARE DIAL.</b> DIAL MOUNTING NO. 22A INCOMPLETE	1 PER INSTN.	FOR REPLACEMENT BY OPERATOR
DIAL NO. 21 LA GREY PART NO. 1/DCO/631	1 PER INSTN. 1 PER INSTN.	
<b>MISCELLANEOUS.</b> FRAME NOTICE NO. 25 GREY.	1 PER POSN. AS REQUIRED	VIF TO REPLACE FRAME NOTICE NO. 38A FITTED
PEGS NO. 15 GREY PART NO. 1/DST/586	AS REQUIRED	FOR SPARE JACKS
1" WHITWORTH BOLTS 2 1/2" WITH NUTS AND WASHERS.	AS REQUIRED	FILLET BETWEEN ADJACENT KEYSHELVES. 5 ARE REQUIRED TO BOLT TOGETHER ANY TWO POSITIONS. N.R.B. LOCAL PURCHASE
PART 3/DBU/74 PART 1/DBR/508	1 PER 2 1/2" BOLT 5 PER POSN.	SPACING BUSH BETWEEN POSNS. MULT. CABLE SUPPORT BRACKETS.
VALVE ELECTRONIC CV 7476	3 PER POSN.	SEE ITEM 5.

**INSTALLATION.****3. LOCATION OF SWITCHBOARDS.**

THE SUITE OF SWITCHBOARDS SHOULD BE SITED TAKING INTO ACCOUNT THE FOLLOWING:-

- MAINTENANCE ACCESS TO THE REAR OF THE SWITCHBOARDS.
- CABLING ACCESS VIA FLOOR CHASES OR TROUGHING WITH CAPPING.
- FLOOR LOADINGS.
- POSSIBLE FUTURE GROWTH.

NOTE: THE FRONTS OF THE SWITCHBOARDS MAY BE LOWERED TO REDUCE THEIR DEPTH TO PASS THROUGH NARROW DOORWAYS, FOR DETAILS SEE E. I.

**4. LOCATION OF ANCILLARY EQUIPMENT.**

THE SMALLER ANCILLARY EQUIPMENT HAS BEEN DESIGNED FOR WALL MOUNTING AND LARGER ITEMS AS FREE STANDING. ALL THE ITEMS CAN BE ASSOCIATED TOGETHER OR SEPARATED IN GROUPS DEPENDENT ON THE ACCOMMODATION AVAILABLE.

CARE SHOULD BE TAKEN TO ENSURE THAT THE SITING OF THE ANCILLARY EQUIPMENT DOES NOT DETRACT FROM THE APPEARANCE OF THE INSTALLATION MAINTENANCE ACCESS TO THE EQUIPMENT SHOULD NOT BE OVERLOOKED. THE CHASSIS OF ALL UNITS (RESPECTIVE OF LOCATION SHALL BE BONDED TO EARTH POTENTIAL. A GOOD EARTH SHOULD BE PROVIDED FOR P.O. USE.

**5. SWITCHBOARD - GENERAL DETAILS.**

IN THE EXTREME LEFT POSITION OF ANY SUITE PROVIDE STRAPS, CL 4-8, CL 5-9, CL 6-11 AND CL 10-12 ON STRIP CONNEXION AT BOTTOM OF POSITION TO MAKE COUPLE KEY INEFFECTIVE.

IF NON-THROUGH CLEARING HAS BEEN AUTHORISED PROVIDE STRAPS U6 - UB AND U56 - U58 IN R/S SA 7602.

IN CB AREAS WITH NO DIALLING CIRCUITS TO PABX'S REMOVE DIAL AND MOUNTING PLATE NO. 5B AND FIT MOUNTING PLATE NO. 5A. THE 2 WIRES TO THE DIAL MOUNTING SHOULD BE CONNECTED TOGETHER, INSULATED AND TIED BACK INTO THE FORM.

WHERE A FRAME NOTICE NO. 25 GREY IS AUTHORISED THE FRAME NOTICE NO. 38A SHOULD BE RECOVERED.

TOOLS ARE SUPPLIED WITH THE SWITCHBOARDS FOR EXCHANGE LINES, CORD CIRCUITS ETC., AND SHOULD BE INSERTED ON THE FUSE PANEL AS DETAILED IN D/SM SAW 7600. THE RATING REQUIRED IS SPECIFIED ON THE RELATIVE SAW DIAGRAM.

DETAILS OF THE LAYOUT OF SWITCHBOARD EQUIPMENTS AND STRIP CONNEXION ALLOCATION IS SHOWN IN ITEM 21 AND FACE EQUIPMENTS ON ITEM 20 ADJACENT POSNS. MUST BE BOLTED TOGETHER USING 2 1/2" BSW BOLTS AND ADJACENT KEYSHELVES MADE CONTINUOUS BY THE PROVISION OF PART 1/DST/536. THE NECESSARY SIDE PANELS SHOULD BE REMOVED AS DETAILED IN E. I.

LABELS NO. 461C AND 461F SHOULD BE PROVIDED AND THE EXISTING LABELS NO. 461B AND 461D RETURNED TO SUPPLIES DEPT.

ON THE REAR OF THE CONNEXION STRIPS FOR BATTERY SUPPLIES ON ALL POSITIONS CARRY OUT THE FOLLOWING PROCEDURE:-

- CHECK THE PILOT RELAY CIRCUIT WIRING TO THE PB BATTERY TAGS. IF THE BLUE-SLATE WIRE IS TERMINATED ON TAG 1 TRANSFER IT TO TAG 5. IF THE RED-ORANGE WIRE IS TERMINATED ON TAG 16 TRANSFER IT TO TAG 22. REMOVE STRAPS BETWEEN TAGS 4 & 5, AND 16 & 17, CONNECT A VALVE ELECTRONIC CV 7476 BETWEEN EACH OF THESE PAIRS OF TAGS WITH THE POSITIVE ENDS ON TAGS 5 & 17 RESPECTIVELY.
- CHECK THE PILOT RELAY CIRCUIT WIRING TO PB BATTERY TAGS. IF THE BLUE-SLATE WIRE IS TERMINATED ON TAG 1 TRANSFER IT TO TAG 5. REMOVE THE STRAP BETWEEN TAGS 4-5. CONNECT A VALVE ELECTRONIC CV 7476 BETWEEN THESE TAGS WITH THE POSITIVE END ON TAG 5.

**6. EXTENSIONS.**

ALL EXTENSION INSTRUMENTS SHOULD BE CONNECTED IN ACCORDANCE WITH N806 AND ARRANGED FOR "EARTH RECALL". THE GROWTH OF EXTENSION ANSWERING EQUIPMENT IS OBTAINED BY THE INSERTION OF PABX NO. 4 EXTN. UNITS NOS. 1 AND 2 AND REMOVAL OF SPACING STRIPS.

FOR DETAILS SEE DRG. E.5 6283.

THE EXTENSION MULTIPLE IS OBTAINED BY THE PROVISION OF PABX NO. 4 EXTN. UNITS NOS. 3 AND 4 AND RE-ARRANGEMENTS OF SPACING STRIPS; FOR DETAILS OF SPACING STRIPS SEE N 2233.

THE CONNEXION STRIPS ATTACHED TO BOTH TYPES OF EXTENSION UNITS ARE POSITIONED IN THE TOP OF THE SWITCHBOARD AS

SHOWN IN ITEM 21. THE BATTERY (VIA PULL) AND EARTH CONNEXION LEADS ASSOCIATED WITH THE ADDITIONAL ANSWER JACKS SHOULD BE CONNECTED TO THE PANEL TERMINAL STRIP AS DETAILED ON ITEM 28 LAMPS NO. 2 45V ARE FITTED AS REQUIRED. KITS NO. 133A-19 SHOULD BE PROVIDED AS APPROPRIATE. THE CAPS LAMP NO. 76A OPAL ENGRAVED 0-49 RECOVERED FROM POSITIONS 2,3 OR 4 SHOULD BE RETURNED TO SUPPLIES DEPT. AS KITS NO. 133/0, NO. 133/1, NO. 133/2 AND NO. 133/3.

LONG EXTENSION LINE CALLING AND DUPLICATE CALLING APPEARANCE FACILITIES ARE PROVIDED BY MEANS OF UNIT SIGNALLING SA 7611 WHICH Caters FOR 10 CIRCUITS. FOR DETAILS SEE DIAGRAM N 2235.

**7. EXCHANGE LINES (WHERE MORE THAN 10 REQUIRED.)**

FOR THE PROVISION OF EXCHANGE LINES 11-20, 1 JACK NO. 710 BR, 1 JACK LAMP NO. 61 20 AND 1 COVER LAMP NO. 8/20 PER POSITION ARE REQUIRED. WIRING IS PROVIDED AND SHOULD BE TERMINATED AS SHOWN ON SAW 76010. FOR EXCHANGE LINES 21-30 AND 31-40 SIMILAR EQUIPMENT IS REQUIRED PER 10 CCTS TOGETHER WITH A STRIP CONNEXION NO. 15A 9A (CAPACITY 20 CCTS) FITTED TO THE RIGHT OF THE EXCHANGE LINES 1-20 STRIP CONNEXION MOUNTED IN THE BASE. WIRING IN ACCORDANCE WITH SAW 76010 SHOULD BE PROVIDED IN THESE INSTANCES. CAPS LAMP NO. 76A OPAL AND CAPS LAMP NO. 76A LIGHT GREY SHOULD BE PROVIDED AS APPROPRIATE.

**8. INTER-SWBD. LINES.**

WHEN AN INTERSWITCHBOARD CIRCUIT IS REQUIRED REFERENCE SHOULD BE MADE TO THE RELATIVE N DIAGRAM FOR THE PARTICULARS OF METHOD OF CONNEXION. WHERE MORE THAN 5 INTERSWBD. CIRCUITS ARE REQUIRED ADDITIONAL JACKS AND LAMP JACKS SHOULD BE FITTED TO THE EXISTING MOUNTINGS AND WIRING UP TO A MAXIMUM OF 10.

**9. DISTRIBUTION.**

TYPICAL ASSEMBLIES OF DISTRIBUTION MOUNTINGS FOR THE VARIOUS SIZES OF INSTALLATION ARE SHOWN ON DRAWING SO 136 TOGETHER WITH APPARATUS LAYOUT. PLINTH D 92270 NORMALLY FLOOR MOUNTED PROVIDES CABLE ACCESS AS WELL AS STORAGE SPACE FOR SPARES AND DIAGRAMS. MOUNTINGS D 92221 SHOULD BE PROVIDED AS REQUIRED AND BOLTED ON TOP OF THE PLINTH, INTERMEDIATE TOP COVERS BEING REMOVED BEFORE ASSEMBLY. WHERE GROWTH VERTICALLY IS LIMITED, GROWTH HORIZONTALLY IS PERMISSIBLE, AN ADDITIONAL PLINTH IS THEN REQUIRED AND ADJACENT SIDE COVERS ARE ALSO REMOVED. ALL SURPLUS COVERS (TOP - 2,DCO/686, SIDE - 3/DCO/686) SHOULD BE RETURNED TO SUPPLIES DEPT. THE EQUIPMENT IN MOUNTING D 92221 IS WIRED AS SHOWN IN ITEM 13 AND THE FOLLOWING SHOULD BE PROVIDED AS REQUIRED:-

- JACKS TEST NO. 33-1A (PER 50 CCTS) ON THE A AND B WIRES OF ALL CIRCUITS TO PROVIDE A MAINTENANCE TEST AND INTERCEPTION POINT.
- STRIPS CONNEXION NO. 150V... TO TERMINATE DISTRIBUTION CABLES TO EXTENSIONS, AND TO TERMINATE CABLING FROM UNITS SIGNALLING AND MISCELLANEOUS SERVICES.
- FUSE MOUNTINGS R064 B (PER 40 CCTS) TO TERMINATE EXTERNAL CIRCUITS AND PROVIDE FUSED PROTECTION AS NECESSARY. THESE FUSE MOUNTINGS CAN ONLY BE FITTED IN THE POSITION OF THE TWO RIGHT HAND VERTICALS. AFTER REMOVAL OF THE MOUNTING BAR, WHERE THE NUMBER OF CIRCUITS REQUIRING PROTECTION DOES NOT EXCEED 15, FUSE MOUNTINGS NO. 1064A SHOULD BE PROVIDED. EACH FUSE MOUNTING NO. 1064A Caters FOR 5 CIRCUITS AND WHEN USED UP TO THREE OF THESE MOUNTINGS CAN BE FITTED ON PART NO. 1/DAD/119 BOLTED TO THE VERTICAL.  
IN BLOCK WIRED BUILDINGS THE EARTH FOR RECALL PURPOSES IS NORMALLY OBTAINED FROM THE BLOCK WIRING DISTRIBUTION. IN NON BLOCK WIRED BUILDINGS THE EARTH IS DISTRIBUTED FROM THE MOUNTING D 92221.

**10. POWER AND RINGING SUPPLY**

THE SWITCHBOARD IS NORMALLY OPERATED FROM A MAINS OPERATED POWER UNIT PROVIDING 50V D.C. WHEN AUTHORISED A FLOATED BATTERY IS PROVIDED. FOR DETAILS OF POWER EQUIPMENT SEE ITEMS 23 TO 25.  
THE CONVERTERS RINGING NO. 11A AND 12A OPERATE FROM A 50V DC SOURCE.

**11. AUDIBLE CLEAR.**

WHEN AUTHORISED SUB-UNITS SA 7606 AND RELAYS 16790 SHOULD BE FITTED IN RELAY SETS SA 7604. OPERATORS AND MISCELLANEOUS RELAY SETS. THE WIRING IS PROVIDED AND SHOULD BE CONNECTED IN ACCORDANCE WITH SAW 76090 AND SAW 76040.

**12. ENGAGED TEST**

SUB-UNITS SA 7606 ARE PROVIDED IN UNITS AND ARE FITTED IN RELAY SET SA 7604 IN THE JACK PROVIDED.

13. TYPICAL DISTRIBUTION CABLING AND JUMPERING.

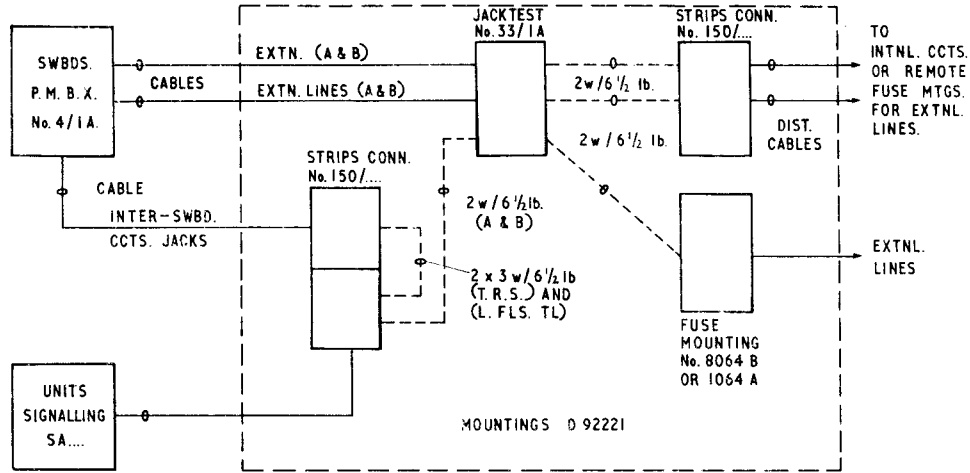

FIG. 2.

14. PROVISION OF EXCHANGE LINE RELAY SETS.

EXCHANGE LINE RELAY SETS WILL BE RELAY SETS NO. 1/SA7603 (3 PER BASE) PLUS NOT MORE THAN TWO RELAY SETS NO. 2/SA7603 (2 PER BASE) TO PROVIDE FOR THE EXACT NUMBER OF EXCHANGE LINES REQUIRED.  
 E.G. 15 EXCHANGE LINES WOULD BE CATERED FOR BY 5 RELAY SETS NO. 1/SA7603,  
 16 EXCHANGE LINES BY 4 RELAY SETS NO. 1/SA7603 PLUS 2 RELAY SETS NO. 2/SA7603 AND 17 EXCHANGE LINES BY 5 RELAY SETS NO. 1/SA7603 PLUS 1 RELAY SETS NO. 2/SA7603. TO AVOID REARRANGEMENT, LOCAL DISCRETION SHOULD BE USED AND ADDITIONAL E/L R/S EQUIPMENTS MAY BE PROVIDED AT THE OUTSET, IF AN INCREASE IN THE NUMBER OF EXCHANGE LINES IS FORESEEN IN THE NEAR FUTURE.

15. ALLOCATION OF EXCHANGE LINE EQUIPMENTS IN EACH POSITION.

THE EXCHANGE LINE RELAY SETS SHOULD BE DISTRIBUTED AS EVENLY AS POSSIBLE OVER ALL POSITIONS. WHEN THE NUMBER OF RELAY SETS HAS BEEN DETERMINED, E.G. IF 17 EXCHANGE LINES ARE REQUIRED FOR A 3 POSITION INSTALLATION THEN PROVIDE 5 RELAY SETS NO. 1/SA7603 AND 1 RELAY SET NO. 2/SA7603 AND EQUIP POSITION 1 AND 2 WITH 6 EXCHANGE LINES AND POSITION 3 WITH EQUIPMENT FOR 5 EXCHANGE LINES. TABLE 2 DETAILS THE LOCATION OF THE RELAY SETS IN EACH POSITION AND THE CIRCUIT NUMBERS ON THE STRIP CONNECTION EQUIPPED. WHEN 11 OR MORE EXCHANGE LINES ARE REQUIRED AT AN INSTALLATION FACE EQUIPMENT IS REQUIRED IN EACH POSITION. SEE ITEM 7 AND ITEM 2 FOR STORES.

TABLE 2.

NO. OF EXCHANGE LINE CIRCUITS IN ANY POSITION	RELAY SET REQUIRED		RELAY SET POSITION IN SWITCHBOARD	CCT. NO. ON THE STRIP CONNECTION EQUIPPED BY RELAY SETS.
	NO.	QTY.		
2	2/SA7603	1	1-3	1 AND 2
3	1/SA7603	1	1-3	1, 2 AND 3
4	2/SA7603	2	1-3, 4-6	1, 2, 4 AND 5
5	1/SA7603	1	1-3	1, 2 AND 3
	2/SA7603	1	4-6	4 AND 5
6	1/SA7603	2	1-3, 4-6	1-6
7	1/SA7603	1	1-3	1, 2 AND 3
8	2/SA7603	2	4-6, 7-9	4 AND 5, 7 AND 8
	1/SA7603	2	1-3, 4-6	1-6
9	1/SA7603	3	1-3, 4-6, 7-9	1-9
10	1/SA7603	2	1-3, 4-6	1-6
11	2/SA7603	2	7-9, 10-12	7 AND 8, 10 AND 11
	1/SA7603	3	1-3, 4-6, 7-9	1-9
12	2/SA7603	1	10-12	10 AND 11
	1/SA7603	4	1-3, 4-6, 7-9, 10-12	1-12

16. EXCHANGE LINE MULTIPLE CABLING AND WIRING.

IN DIAGRAM N 2233 AN EXPLANATORY DIAGRAM SHOWS THE METHOD OF CONNECTION OF THE EXCHANGE LINE RELAY SETS AND JACKS.

TABLE 3 JACK MULTIPLE CABLING AND RELAY SET JUMPERING (NOTE D)

E/L JACK NO.	CABLE COLOURS (NOTE A)	EXCH. LINE JACK STRIP CONNECTION TAGS (NOTE E)				JUMPER COLOURS (NOTE B)	RELAY SET STRIP CONN. (NOTE C & F)
		POSN. 1	POSN. 2	POSN. 3	POSN. 4		
1	WHITE	T	T	T	T	WHITE	LT
	BLUE	R	R	R	R	RED	LR
	W OF BROWN	S	S	S	S	GREEN	MS
	WHITE	L	L	L	L	BLUE	CL
	ORANGE	FLS	FLS	FLS	FLS	RED-BLUE	FLS
	WHITE	TL	TM	TL	TM	NOTES G	
2	SLATE	R	R	R	R	WHITE	LT
	BROWN	S	S	S	S	RED	LR
	WHITE	L	L	L	L	GREEN	MS
	BLUE-WHITE	FLS	FLS	FLS	FLS	BLUE	CL
	WHITE	TL	TM	TL	TM	NOTES G	
	BLUE-ORANGE	RL	RM	RL	RM	NOTES G	

NOTES.

- A CABLE PVC NO. 3A... SEE ITEM 27
- B THE RELAY SET IS JUMPERED TO THE EXCHANGE LINE MULTIPLE ON THE POSN. IN WHICH THE R/S IS FITTED USING WIRE P.V.C. NO. 1 5w/6 1/2 lb.
- C WHEN FLS IS REQUIRED STRAP E-Y ON R/S STRIP CONN. OF 1ST. EXCHANGE LINE CCT OF GROUP AND 1ST. X - 2ND. Y, 2ND. X - 3RD. Y ETC. SEE ITEM 28. WHEN A STRAP IS REQUIRED BETWEEN POSITIONS A SPARE CONDUCTOR IN THE 31W TIE CABLE SHOULD BE USED. CAPS LAMP NO. 76B SHOULD BE FITTED IN THE FLS LAMP POSN. AND LAMPS NO. 2 45V FITTED TO ALL JACKS EXCEPT THE FIRST.
- D TWO CIRCUITS SHOWN, OTHERS SIMILARLY WIRED.
- E T.R.S.L. FLS ARE PARALLEL MULTIPLIED AND TM-TL, RM-RL ARE SERIES MULTIPLIED BETWEEN POSITIONS
- F E/L A AND B CABLED FROM DISTRIBUTION ARE CONNECTED TO R/S STRIP CONN. A&B SEE ITEM 28 AND CABLING SCHEDULE ITEM 27
- G SEE TABLE 4 FOR THE CABLE ARRANGEMENT.

17. EXCHANGE LINE RELAY SET TIE CABLES (SEE ALSO TABLE 3)

TABLE 4

LOCATION OF RELAY SET (NOTE D)	EXCH. LINE JACK STRIP CONN. IN POSN. 1	RELAY SET TO TIE CABLE CONNECTIONS (NOTE C)								EXCH. LINE JACK STRIP CONN. IN LAST POSN.
		POSITION 1		POSITION 2 (NOTE A)		POSITION 3 (NOTE B)		POSITION 4		
POSN. 1	TL RL	{ CT   AC   F }		{ 1   TO 24 }		{ 1   TO 24 }		{ 1   TO 24 }		TM RM
POSN. 2	TL RL	{ 26   TO 49 }	{ CT   AC   F }			{ 26   TO 49 }		{ 26   TO 49 }		TM RM
POSN. 3	TL RL	{ 51   TO 74 }		{ 51   TO 74 }	{ CT   AC   F }			{ 51   TO 74 }		TM RM
POSN. 4	TL RL	{ 1   TO 24 }				{ 1   TO 24 }	{ CT   AC   F }			TM RM

————— CABLES ————— JUMPERS (NOTE F)

NOTES.

- A IF 2 POSNS. ONLY ARE FITTED THESE CONNECTIONS ARE JUMPERED TO JACK TAGS TM & RM IN POSN. 2
- B IF 3 POSNS. ONLY ARE FITTED THESE CONNECTIONS ARE JUMPERED TO JACK TAGS TM & RM IN POSN. 3
- C THE TIE CABLE TAGS ARE ALLOCATED TO PERMIT EQUIPMENT FOR 12 EXCHANGE LINES IN ANY POSITION AND FOR GROWTH FROM 2 TO 3 OR 3 TO 4 POSITIONS (SEE ALSO NOTE E). IF 3 OR 4 POSITIONS ARE PROVIDED INITIALLY THE TIE CABLES FROM R/S IN POSITIONS 1 & 2 SHOULD BE CABLED DIRECT TO THE LAST POSITION AND TIE CABLE FROM R/S IN POSITION 3 DIRECT TO POSITION 1.
- D A MAXIMUM OF 40 E/L CCTS ONLY MAY BE PROVIDED AT ANY INSTALLATION. IF UP TO 40 E/L CCTS ARE REQUIRED ON 2 OR 3 POSITION INSTALLATIONS UNITS SIGNALLING SA7616 SHOULD BE FITTED EXTERNAL TO THE SWITCHBOARD. SEE ITEM 18.
- E WHEN AN INSTALLATION GROWS FROM 2 TO 3 OR 3 TO 4 POSITIONS THE JUMPERS FROM THE CABLE TAGS 1-24 IN POSITION 2 AND 25-48 IN POSITION 3 SHOULD BE TRANSFERRED TO POSITIONS 3 AND 4 AS APPROPRIATE AND THE TIE CABLES EXTENDED.
- F CABLE P.V.C. NO. 1 31W/6 1/2 lb. PER 12 CCTS. JUMPERS - WIRE P.V.C. NO. 1 2w/6 1/2 lb.
- G WHEN THE NUMBER OF EXCHANGE LINES IS INCREASED AFTER THE INITIAL PROVISION, REARRANGEMENTS SHOULD BE MADE IN ACCORDANCE WITH TABLES 2 AND 4. RE-JUMPERING WILL BE NECESSARY ON SOME CCTS BETWEEN E/L R/S AND JACKS. TIE CABLE PAIRS AND E/L JACKS AND LINE PAIRS AND E/L R/S IN THE DISTRIBUTION.

19. EXTENSION LINES. Cabling & Jumpering.

EXPLANATORY DIAG. N 2233 SHOWS THE METHOD OF INTERCONNECTION OF THE EXTENSION ANSWER AND MULTIPLE JACKS AND TABLE 5 BELOW SHOWS THE CABLING AND JUMPERING ARRANGEMENTS INVOLVED. THE T, R AND S TAGS OF THE MULTIPLE JACKS (P.M.B. X NO. 4 EXTN. UNITS NOS. 3 AND 4) ARE PARALLEL MULTIPLED BETWEEN ALL JACKS AND JUMPERED TO THE ANSWER JACK T, R, AND S TAGS IN THE POSITION CONTAINING THE ANSWER JACK. THE TL, RL AND TM, RM TAGS OF THE MULTIPLE JACKS ARE SERIES MULTIPLED THROUGH THE BREAK SPRINGS ON ALL POSITIONS. THE ANSWER JACK TL AND RL TAGS ARE CABLED TO CONCENTRATOR BLOCKS IN THE LAST POSITION. THE CONCENTRATOR BLOCK TAGS ARE JUMPERED TO THE MULTIPLE JACK TM AND RM TAGS. ON THE FIRST MULTIPLE APPEARANCE THE MULTIPLE JACK TL AND RL TAGS ARE STRAPPED TO T AND R RESPECTIVELY. THE A AND B CONNECTIONS (LINE PAIR) TO THE DISTRIBUTION ARE CONNECTED TO THE T AND R TAGS ON THE EXTN. ANS. BLOCK

TABLE 5. EXAMPLES OF EXTENSION CABLING ARRANGEMENTS

EXTENSION NUMBER	MULTIPLE CABLE (NOTE A)	EXTENSION MULTIPLE STRIP CONNECTIONS				EXTENSION ANSWERING STRIP CONNECTION			STRIPS CONNECTION IN LAST POSITION		
		POSITION 1 (NOTE B)	POSITION 2	POSITION 3	POSITION 4	ANSWER STRIP CONN. (NOTES C & E)	JUMPER TO MULT. JACK STRIP CONN. IN SAME POSN.	CABLE TO CONC. STRIP CONN. IN LAST POSN.	CONC. STRIP CONN. (NOTE D)	JUMPER COLOURS	EXTN. MULT. STRIP CONN.
0	WHITE } BLUE } W OF GREEN }	T R S	T R S	T R S	T R S	T R S	- - -	- - -	- - -	- - -	- - -
	WHITE } ORANGE }	TL   TM RL   RM	TL   TM RL   RM	TL   TM RL   RM	TL   TM RL   RM	TL RL	- -	WHITE } COLOUR }	CONC 0	RED RED-BLUE	TM RM
1	WHITE } BROWN } GREEN }	T R S	T R S	T R S	T R S	T R S	- - -	- - -	- - -	- - -	- - -
	WHITE } SLATE }	TL   TM RL   RM	TL   TM RL   RM	TL   TM RL   RM	TL   TM RL   RM	TL RL	- -	WHITE } COLOUR }	CONC 1	RED RED-BLUE	TM RM

NOTES.

- A. CABLE PVC NO. 3A/11 6/16B JUMPER - WIRE PVC NO. 1 2W OR 3W/6/6B
- B. STRAP MULTIPLE JACK T, TL AND R, RL ON FIRST POSITION.
- C. VARIATION OF THE 3W (T, R, AND S) AND 2W (TL AND RM) JUMPER ALLOWED ANY ANSWER JACK TO BE ASSOCIATED WITH ANY MULTIPLE JACK.
- D. STRIPS CONNEX ON NO.10/7/6A (10 X 6 GAUS) ARE USED FOR THE CONCENTRATOR BLOCK AND CATER FOR 30 CUTS PER STRIP CONNECTION. A MAXIMUM OF 6 STRIPS CONNECTION MAY BE PROVIDED IN A STANDARD POSITION. AS STOCKED (I.E.) NO. ADDITIONAL EXTN. CUTS OVER 40 PROVIDED. REFERENCE SHOULD BE MADE TO DIAG. ES E293 TO ENSURE THAT ANY EXTENSION ANSWERING EQUIPMENT AND SUBSEQUENT CONCENTRATOR ARRANGEMENT IS POSSIBLE.
- E. THE EXTENSION ANSWER CUTS IN THE LAST POSITION OF A SUITE ARE JUMPERED STRAIGHT TO THE MULTIPLE JACKS (T, R, S, TL, RL TO T, R, S, TM, RM) NO. CONCENTRATOR BLOCK IS NECESSARY. WHEN A 2 OR 3 POSITION INSTALLATION GROWS THE CONCENTRATOR CABLE(S) IS EXTENDED TO THE NEW LAST POSITION AND THE JUMPER TRANSFERRED TO THE LAST POSITION. A NEW CONCENTRATOR CABLE SHOULD BE PROVIDED TO EXTEND CIRCUITS PREVIOUSLY JUMPERED DIRECT ON THE NOW LAST BUT ONE POSITION.

20. FACE EQUIPMENT OF POSITION (FULLY EQUIPPED)

FIG. 3. FACE EQUIPMENT VIEWED FROM FRONT.

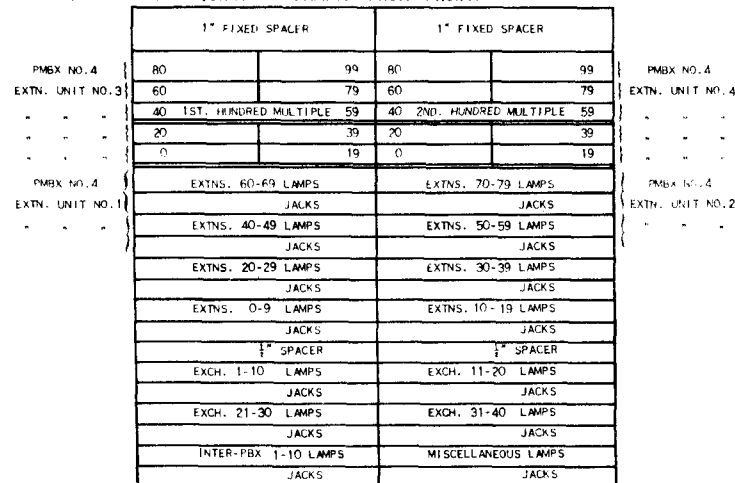

21. LOCATION AND INTERCONNECTION OF STRIPS CONNECTION FOR ANSWER JACKS, MULTIPLE JACKS AND CONCENTRATOR BLOCKS. (ALL STRIPS CONNECTION MOUNTED UNDER REMOVABLE TOP OF SWBD.)

FIG. 4A MOUNTING POSITION ALLOCATION.

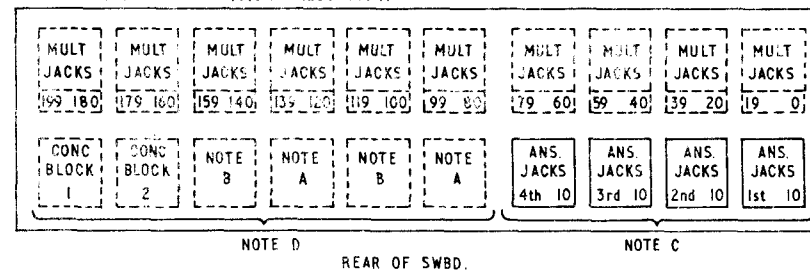

NOTES.

- A. CONCENTRATOR BLOCK OR ANSWER JACKS (PMBX NO. 4 EXTN. UNIT NO. 1) DEPENDENT ON NUMBER OF POSITIONS IN INSTALLATION AND ALLOCATION OF EXTENSION LINES TO POSITIONS. PMBX NO. 4 ES E293
- B. AS FOR NOTE A EXCEPT THAT ANSWER JACKS WOULD BE PMBX NO. 4 EXTN. UNIT NO. 2.
- C. PROVIDED IN SWITCHBOARD WHEN RECEIVED.
- D. CONCENTRATOR BLOCKS ARE ONLY FITTED IN LAST POSITION OF SUITE BUT EXISTING BLOCKS ARE LEFT IN WHEN AN INSTALLATION IS EXTENDED.

FIG. 4B TYPICAL INTERCONNECTION OF EXTENSION CABLING.

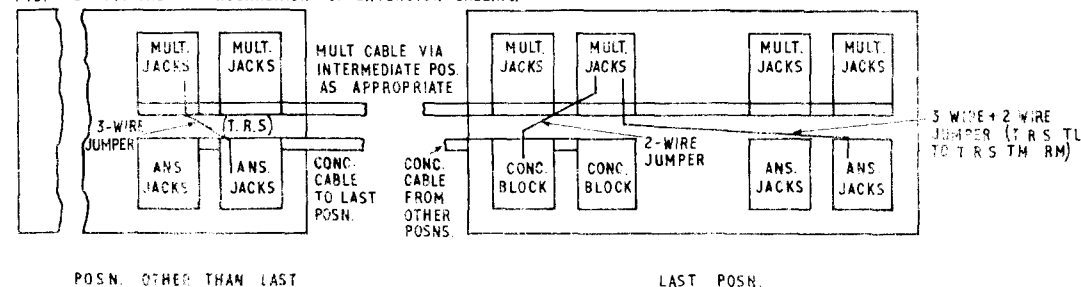

22. INTER-SWITCHBOARD AND PRIVATE CIRCUITS.

THE UNIT SIGNALLING TERMINATIONS ARE DETAILED ON THE RELEVANT APPLICATION N-DIAGRAMS FOR THE PARTICULAR UNIT. THE INTERSWITCHBOARD OR PRIVATE CIRCUIT JACKS ARE CONNECTED AS A PARALLEL MULTIPLE AS DETAILED IN TABLE 7. THE CABLES TO THE DISTRIBUTION ARE TERMINATED IN POSITION 1.

TABLE 6. EXAMPLES OF INTER PBX CCT. CABLING.

(NOTES C A D) INTER-PBX JACK NO.	INTER PBX JACKS STRIP CONN.	(NOTE A) CABLING BETWEEN POSNS. AND TO DISTN.
1	T	WHITE
	R	BLUE
	S	WHITE
	L	ORANGE
	FLS	WHITE
2	TL	GREEN
	TM	(NOTE B)
	T	WHITE
	R	BROWN
	S	WHITE
	L	SLATE
	FLS	WHITE
TL	BLUE WHITE	
	TM	(NOTE B)

NOTES.

- A. CABLE PVC NO. 3A... 6 1/2 B. CIRCUIT CONNECTIONS PARALLEL MULTIPLE BETWEEN POSITIONS.
- B. STRAP TM TO E OR MF ON STRIP CONNECTION IN ALL POSITIONS AS REQUIRED; SEE N DIAGRAM FOR THE UNIT SIGNALLING.
- C. FLS MAY BE PROVIDED ON ROUTES WITH 3 OR MORE CIRCUITS. WHEN THIS FACILITY IS REQUIRED A PART 1/DJA 13 IS FITTED PER CIRCUIT AND THE EXISTING 10-WAY LAMP COVER STRIP (COVER LAMP NO. B-10A) IS REPLACED BY A 20 WAY LAMP COVER STRIP (COVER LAMP NO. B-20 A) CAPS LAMP NO. 76 B (ARRANGED FOR FLS INDICATION), CAPS LAMP NO. 76A OPAL (CALL LAMP DESIGNATION) AND CAPS LAMP NO. 76 A LIGHT FRENCH GREY (DUMMY) ARE FITTED AS REQUIRED. THE FIRST LINE OF THE GROUP IS NOT LAMPED FOR FLS. FOR FLS STRAPPING SEE RELEVANT DIAGRAM OF UNIT SIGNALLING ASSOCIATED WITH THE CIRCUITS.
- D. CIRCUITS 1 AND 2 ONLY SHOWN OTHER CIRCUITS SIMILARLY WIRED.

23. DETERMINATION OF CURRENT CONSUMPTION.

TO DETERMINE THE SIZE OF POWER PLANT TO BE PROVIDED THE CURRENT CONSUMPTION FOR THE INSTALLATION SHOULD BE CALCULATED AS FOLLOWS:-

- 0.5 A = CURRENT PER POSITION
- 0.25A = CURRENT CORD CIRCUIT
- 0.25A = CURRENT PER UNIT SIGNALLING (UNIT SIG. SA 7611 AND SA 7616 SHOULD BE NEGLECTED)

EXAMPLE:- 3 POSITION EACH WITH 12 CORD CIRCUITS AND 3 INTERSWITCHBOARD CIRCUITS  
= (3 x 0.5) + (3 x 12 x 0.25) + (3 x 0.25) = 11.25 AMPS.

PROVIDE A POWER SUPPLY IN ACCORDANCE WITH TABLE 8 OR 10 AS APPROPRIATE.  
50V POWER UNITS ARE USED FOR MAINS OPERATED INSTALLATIONS  
50V FROM CELLS SECONDARY FLOATED BY A RECTIFIER FOR INSTALLATIONS WHERE A RESERVE BATTERY IS AUTHORISED.

24. POWER UNIT OPERATED INSTALLATIONS-SUPPLIES AND EQUIPMENT.

(1) - 50V SUPPLY (SEE ITEM 23)

TABLE 7.

FOR CURRENT CONSUMPTION	PROVIDE POWER PLANT
UP TO 8 AMPS	P.U. NO. 77A
8 TO 12 AMPS	P.U. NO. 78A
12 TO 20 AMPS	RECT. NO. 61D AND 12 CAPACITORS No 3165 IN BATTERY UNIT No 1A

FIG. 5. CABLING, POWER UNIT TO FUSE UNIT

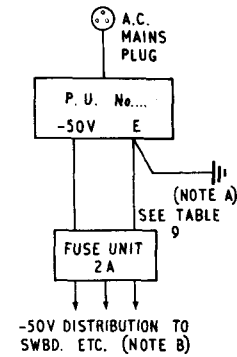

NOTES.

- A P.O. EARTH TO BE INDEPENDENT OF MAINS EARTH AND MUST BE WIRE COPPER SOFT 3/20
- B INSERT STRAP MF 2 TO E ON SWBD. MISC. STRIP CONNECTION OF 1ST POSITION OF SUITE TO PROVIDE POWER FAIL ALARM.

TABLE 8. - CABLING

POWER PLANT	P.U. TO FUSE UNIT CABLE 250V PVC...	MAXIMUM CABLE DISTANCE FROM P.U. TO FUSE UNIT	CABLE TERMINATION IN FUSE UNIT 2A.
P.U. 77A	0.04 SQ. IN.	50 YDS.	SOCKET SOLDERING NO. 5D
P.U. 78A	0.06 SQ. IN.		SOCKET SOLDERING NO. 6D
RECT 61D AND CAPACITORS	0.06 SQ. IN.		SOCKET SOLDERING NO. 6D

- (ii) FUSE UNIT 2A IS PROVIDED TO DISTRIBUTE -50V SUPPLY TO ALL POSITIONS. SIGNALLING UNITS AND MISCELLANEOUS EQUIPMENT. FOR ALLOCATION OF FUSES AND CONNECTIONS SEE ITEM 26.
- (iii) RESERVE BATTERY -50V IS REQUIRED TO PROVIDE SIGNALLING ON EXCHANGE LINE LAMPS UNDER MAINS FAIL CONDITIONS. 2 BATTERIES NO. 16 (250 M/A HR) PER POSITION ARE CONNECTED IN SERIES AND FITTED IN THE BRACKET ON THE RIGHT HAND SIDE IN THE BASE OF EACH POSITION. THE BATTERIES ARE CONNECTED TO THE POSITION MISC. STRIP CONN. AND TRICKLE CHARGED FROM THE P.U. SUPPLY TO THE POSITION. FOR CONNECTIONS SEE DIAG. SAW 76010.
- (iv) RINGING SUPPLY

FOR 2 POSITION INSTALLATIONS PROVIDE CONVERTER RINGING NO. 11A

FOR 3 AND 4 POSITION INSTALLATIONS PROVIDE CONVERTER RINGING NO. 11A AND 12A

THE RINGING CONVERTER IS POWERED FROM FUSE UNIT NO. 2A SEE FIG. 7 AND THE CONNECTIONS IN CONVERTER RINGING NO. 11A AND 12A ARE SHOWN IN DGMS N 682 AND N 683. THE OUTPUT OF RINGING CONVERTERS IS CABLED TO THE MISC. STRIP CONN. IN EACH POSITION.

25. FLOATED BATTERY OPERATED INSTALLATIONS-SUPPLIES AND EQUIPMENT.

(1) - 50V SUPPLY (SEE ITEM 23)

FIG. 6. CABLING, RECTIFIER AND BATTERY TO FUSE UNIT.

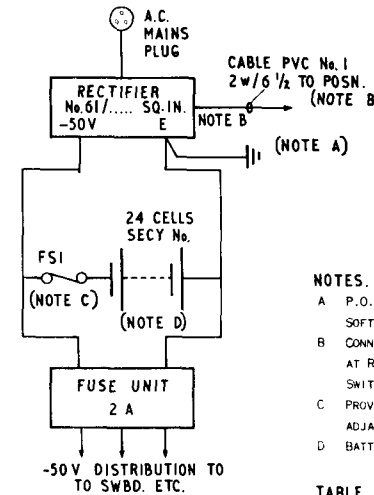

TABLE 9

FOR CURRENT CONSUMPTION	PROVIDE RECTIFIER NO.	PROVIDE CELLS SECY NO... (24 OFF)
UP TO 5 AMPS	61 B	21/30
5 TO 10 AMPS	61 C	21/60
10 TO 15 AMPS	61 D	22/100
15 TO 20 AMPS	61 D	22/150

NOTES.

- A P.O. EARTH TO BE INDEPENDENT OF MAINS EARTH AND MUST BE WIRE COPPER SOFT 3/20.
- B CONNECT CABLE TO ALARM 1 AND 3 AT RECTIFIER AND ALARM 2 TO P.O. EARTH AT RECTIFIER. CONNECT CABLE TO MF1 AND MF2 ON MISC. STRIP CONN. AT SWITCHBOARD ON POSITION 1 OF SUITE. THIS PROVIDES A POWER FAIL ALARM
- C PROVIDE FUSE AS DETAILED IN TABLE 11 IN FUSE MOUNTING NO. 157A ADJACENT TO BATTERY RACK.
- D BATTERY RACK TO BE CONSTRUCTED LOCALLY AS REQUIRED.

TABLE 10. CABLING.

RECTIFIER NO.	RECT AND BATT TO FUSE UNIT CABLE 250V PVC...	MAXIMUM CABLE DISTANCE FROM BATTERY TO FUSE UNIT	CABLE TERMINATION IN FUSE UNIT 2A	FS1 IN FIG. 6 FUSE NO.
61 B	0.01 SQ. INS.	26 YDS.	SOCKET SOLDERING NO. 5D	57/5
61 C	0.04 SQ. INS.	50 YDS.	SOCKET SOLDERING NO. 5D	57/10
61 D	0.06 SQ. INS.	50 YDS.	SOCKET SOLDERING NO. 6D	*57/15

\* PROVIDE 57/25 WHERE CURRENT CONSUMPTION EXCEEDS 15 AMPS.

(II) FUSE UNIT 2A IS PROVIDED TO DISTRIBUTE -50V SUPPLY TO ALL POSITIONS, SIGNALLING UNITS AND MISCELLANEOUS EQUIPMENT. FOR ALLOCATION OF FUSES AND CONNECTIONS SEE ITEM 26.  
(III) RINGING SUPPLY

FOR 2 POSITION INSTALLATIONS PROVIDE CONVERTER RINGING NO. 11A  
FOR 3 AND 4 POSITION INSTALLATIONS PROVIDE CONVERTER RINGING NO. 11A AND 12A

THE RINGING CONVERTER IS POWERED FROM FUSE UNIT NO. 2A SEE FIG. 8 AND THE CONNECTIONS IN CONVERTER RINGING NO. 11A AND 12A ARE SHOWN IN DIAGRAMS N 682 AND N 683. THE OUTPUT OF RINGING CONVERTERS IS CABLED TO THE MISCELLANEOUS STRIP CONNECTION IN EACH POSITION SEE ITEM 27.

27. GENERAL CABLING.

TABLE II.

SERVICE	FROM	TO	WIRE COLOUR	REMARKS
	<u>SWITCHBOARD</u>	<u>DISTRIBUTION</u>		
EXTENSION LINES	T (ANS. JACK BLOCK)	A B	WHITE COLOUR	CABLE PVC NO. 1 41W/6 1/2 LB. PER 20 CCTS. STRAP T TO TL AND R TO RL ON MULT. BLOCK IN POSN. 1. (UNDER TOP OF SWBD.). PROVIDE JUMPERING IN DISTRIBUTION AS NECESSARY (SEE ALSO MULT. AND CONCENTRATOR CABLE BELOW).
EXCHANGE LINES (1-10, 11-20, 21-30, 31-40)	A (RELAY SET) B (STRIP CONN.)	A B	WHITE COLOUR	CABLE PVC NO. 1 21W/6 1/2 LB. PER 10 CCTS. TO POSN. 1, 2, 3 AND 4 AS APPROPRIATE. PROVIDE SWBD. JUMPERING IN ACCORDANCE WITH TABLES 3 & 4 (SEE ALSO MULT. & TIE CABLES BELOW).
(2 AND 3 POSITION INSTALLATIONS ONLY) EXCHANGE LINE R/S EXTNL. TO SWBD. (JACKS)	T, R, S, L, FLS TM, RM, TL, RL X, BZ 3	T, R, S, L, FLS TM, RM, TL, RL X, BZ	SEE ITEM 19	CABLE PVC NO. 1... 6 1/2 LB. 11 WIRES FOR 1ST. CCT. 9 WIRES THEREAFTER. SEE ITEM 18 FOR JUMPERING AND STRAPPING.
INTER-SWBD. JACKS	T R S L FLS TL	T R S L FLS TL	WHITE COLOUR WHITE COLOUR WHITE COLOUR	CABLE PVC NO. 1... 6 1/2 LB. SEE ALSO U/S TO DISTN. CABLING BELOW
	<u>SWITCHBOARD</u>	<u>SWITCHBOARD</u>		
EXTENSION MULTIPLE	POSITION 1, 2 AND 3	POSITION 2, 3 AND 4 (RESPECTIVELY)	SEE ITEM 19	5 WIRES / CCT. CABLE PVC NO. 3A... 6 1/2 LB. AS APPROPRIATE. (SEE ALSO CONCENTRATOR CABLE BELOW)
CONCENTRATOR BLOCK (EXTNS.)	POSITION 1, 2 AND 3	POSITION	SEE ITEM 19	2 WIRES / CCT. CABLE PVC NO. 1 OR 3A... 6 1/2 LB. AS CONVENIENT. PROVIDE 3W AND 2W JUMPERS IN ACCORDANCE WITH TABLE 6
EXCHANGE MULTIPLE	POSITION 1, 2 AND 3	POSITION 2, 3 AND 4 (RESPECTIVELY)	SEE ITEM 16	7 WIRES / CCT. CABLE PVC NO. 1 OR 3A... 6 1/2 LB. AS CONVENIENT. PROVIDE
INTER-PBX MULTIPLE	POSITION 1, 2 AND 3	POSITION 2, 3 AND 4 (RESPECTIVELY)	SEE ITEM 22	5W (T, R, S, L FLS) JUMPER TO ANS JACK IN ACCORDANCE WITH TABLE 3 (SEE ALSO TIE CABLE BELOW)
TIE CABLES	RELAY SET... / SA7603 POSITION 1 F, AC POSITION 2 F, AC POSITION 2 F, CT POSITION 3 F, AC POSITION 3 E, CT POSITION 4 E, CT	POSITION 2, 3 OR 4 TIE CABLE TAGS 1 - 24 POSN. 3 OR 4 TIE CABLE TAGS 26 - 49 POSN. 1 TIE CABLE TAGS 26 - 49 POSITION 4 TIE CABLE TAGS 51 - 74 POSITION 1 OR 2 TIE CABLE TAGS 51 - 74 POSITION 1 TIE CABLE TAGS 1 - 24 POSITIONS	WHITE COLOUR WHITE COLOUR WHITE COLOUR WHITE COLOUR WHITE COLOUR WHITE COLOUR BLACK	2 WIRES / CCT. 2 WIRES / CCT. 2 WIRES / CCT. 2 WIRES / CCT. 2 WIRES / CCT. 2 WIRES / CCT. 2 WIRES / CCT. 2 WIRES / CCT. 1W/20LB. STRAP BZ1 - BZ2 ON POSITION CONTAINING BUZZER
BUZZER COMMON	POSITION 1, 2 AND 3 BZ3	POSITIONS 2, 3 AND 4 (RESPECTIVELY) BZ3	BLACK	
COUPLING	SWITCHBOARD POSN. 1, 2 AND 3	SWITCHBOARD POSNS. 2, 3 AND 4 (RESPECTIVELY)		
	LEFT-HAND POSN. CL 1 CL 2 CL 3 CL 7	RIGHT-HAND POSN. CL 8 CL 9 CL 11 CL 12	SPARE CONDUCTORS OR 31W USED FOR TIE CABLE	POSNS. VIEWED FROM FRONT. STRAP CL 4 - CL 8, CL 5 - CL 9, CL 6 - CL 11 AND CL 10 - CL 12 ON EXTREME LEFT POSN

26. POWER SUPPLY - CABLING AND DISTRIBUTION.

FIG. 7. FUSE UNIT No. 2A CABLING AND DISTRIBUTION.

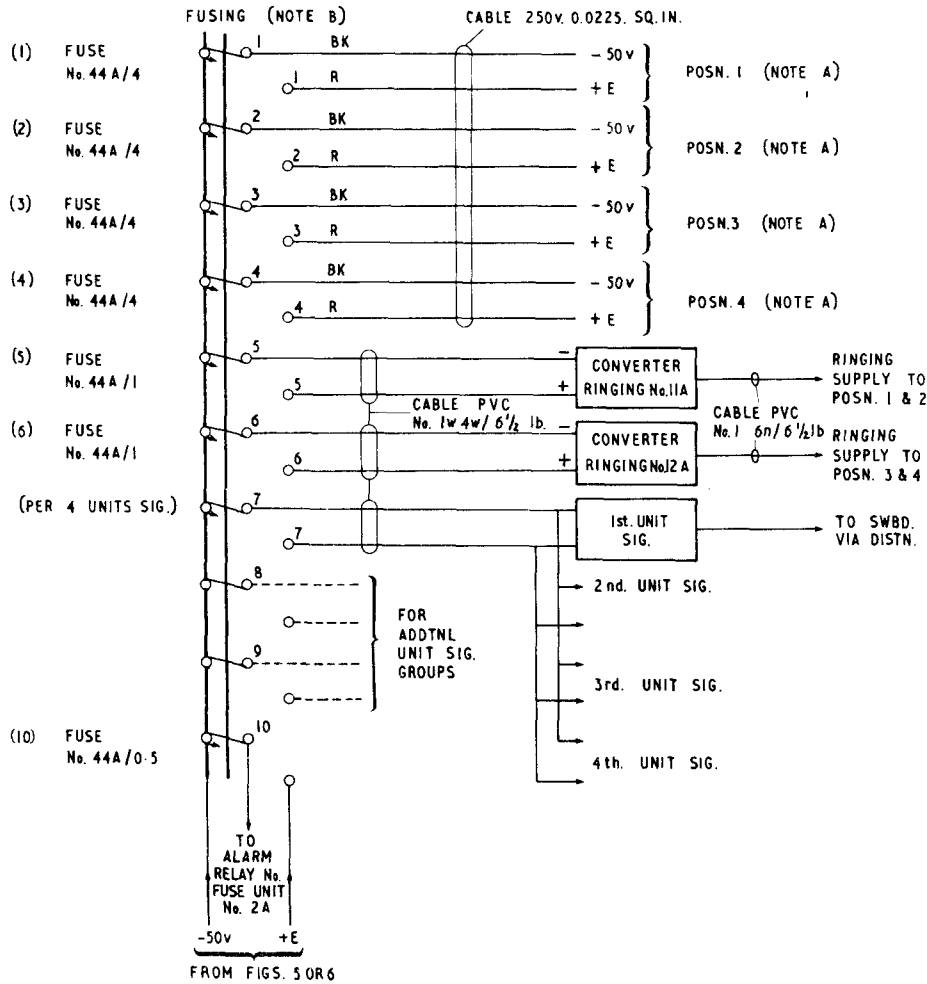

NOTES.

- A CABLE LENGTH OF -50V SUPPLIES FROM FUSE UNIT 2A TO POSITION FUSE MOUNTING 50 YDS MAXIMUM
- B FUSES TO BE REQUISITIONED SEPARATELY AND PROVIDED AS REQUIRED. WHERE MORE THAN 12 UNITS SIG. ARE PROVIDED ANY SPARE FUSE POSITION MAY BE USED.

TABLE II. CONT.

SERVICE	FROM	TO	REMARKS
RINGING SUPPLIES POSN. 1 & 2	POSITIONS 1 AND 2 CONT. RING CONT. R.R. CONT. RING ST INT. RING ST INT. RING INT. R.R.	CONVERTER RINGING NO. 11A 6 16 4 14 2 12 2 12 8 18 10 20	WHITE BLUE WHITE GREEN WHITE ORANGE CR 11A TERMS. 2,4,6,8, & 10 FOR POSN. 1 CR 11A TERMS. 12,14,16,18 & 20 FOR POSN. 2  CABLE PVC NO. 1 6W/6LB. PER POSN.
RINGING SUPPLIES POSN. 3 & 4	POSITION 3 AND 4 CONT. RING CONT. R.R. CONT. RING ST INT. RING ST INT. RING INT. R.R.	CONVERTER RINGING NO. 12A 6 16 4 14 2 12 2 12 8 18 10 20	WHITE BLUE WHITE GREEN WHITE ORANGE CR 12A TERMS. 2,4,6,8, & 10 FOR POSN. 3 CR 12A TERMS. 12,14,16,18, & 20 FOR POSN. 4  CABLE PVC NO. 1 6W/6LB. PER POSN.
RINGING INTERRUPTION FOR CR 12A	CONVERTER RINGING NO. 11A 26 29 22 32 36 38 42 43	CONVERTER RINGING NO. 12A 28 26 22 32 38 36 42 43	WHITE BLUE WHITE ORANGE WHITE GREEN WHITE BROWN CABLE PVC NO. 1 8W/6LB.
UNITS SIG.	UNITS SIG. SA RELEVANT TAGS FOR T.R.S.L. FLS & TL A & B	DISTRIBUTION ALLOCATED BLOCK TAGS FOR TERMS T.R.S.L. FLS & TL A & B	CABLE PVC NO. 1 OR 2A 6LB. AS APPROPRIATE SEE RELEVANT N DIAG. FOR TAG NUMBER ON U/S SA SEE ITEM 13 FOR JUMPERS
FUSE UNIT FUSE ALARM	POSITION 1 FA	FUSE UNIT 2A FA	WHITE A BLUE CABLE PVC NO. 1 2W/6LB. BUNDLED
POWER SUPPLIES	SEE ITEMS 24 AND 25 FOR 50V SUPPLY CABLING		
RESERVE BATTERY (MAINS OPERATED INSTALLATION ONLY)	SWBD. TERMS RES. BATT. + RES. BATT. -	RES. BATT. + 2 BATT. - NO. 16 IN SERIES	BLUE & ORANGE GREEN & BROWN CABLE PVC NO. 1 4W/6LB. BUNDLED
EARTHING	TO MOUNTING D 92221, RECTIFIER. POWER UNIT, FUSE UNIT ETC. AS APPLICABLE		WIRE COPPER SOFT 3/20 EARTH WIRE TO BE INDEPENDENT TO MAINS EARTH

NOTES.

- A FOR METERING CABLING SEE DGM. N 2250
- B THE CABLING TO EXCHANGE LINES, EXTENSIONS ETC. WILL DEPEND ON LOCAL CIRCUMSTANCES
- C CABLE SKINNERS FEEDING ALL CONNEXION STRIPS MUST BE TAKEN VIA THE SLOTS IN THE STRIPS I.E. ALL STRIPS ARE REAR ENTRY THE FANNING STRIP HOLES AND CASTELLATED PORTIONS OF ANY STRIPS ARE FOR JUMPERS ONLY. FOR CONVENIENCE OF WIRING THE STRIPS IN THE BOTTOM OF THE SWITCHBOARD MAY BE REMOVED, AND THOSE IN THE TOP FOR EXTENSION TERMINATIONS MAY BE HINGED UPWARDS

28. SWITCHBOARD - STRIPS CONNEXION LAYOUT

FIG. 8. EQUIPMENT LAYOUT AND STRIP CONNEXION ALLOCATION

(ALL FIGS. VIEWED FROM REAR OF SWITCHBOARD)

FIG. 8A. SWITCHBOARD RELAY SETS.

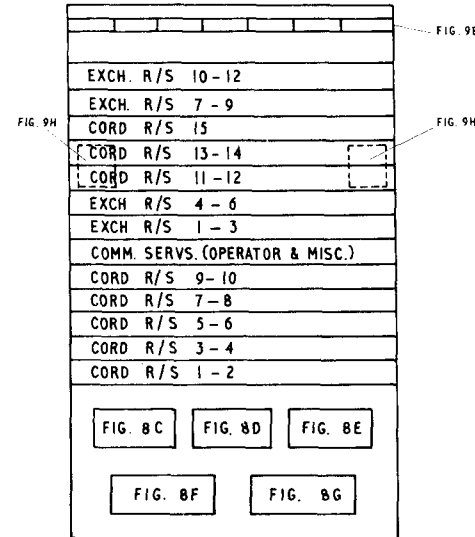

FIG. 8B. STRIP CONNEXIONS FOR EXTENSION UNIT No. 1 OR 2.

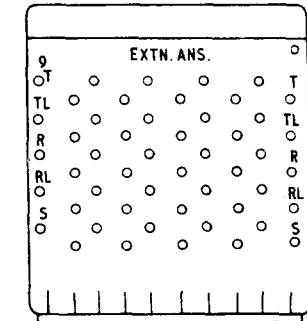

FIG. 8C. STRIP CONNEXION FOR EXCHANGE LINE R/S

