

C.B.S. Nos 2 & 3 SYSTEMS - SWITCHBOARDS B.E., C.B.S., No 2, CORDLESS.

WITH NIGHT SERVICE OVER JUNCTION TO A MAIN EXCHANGE.

FIG. 1. OPERATING TELEPHONE WHEN NIGHT SERVICE REQUIRED AT SWITCHBOARD.

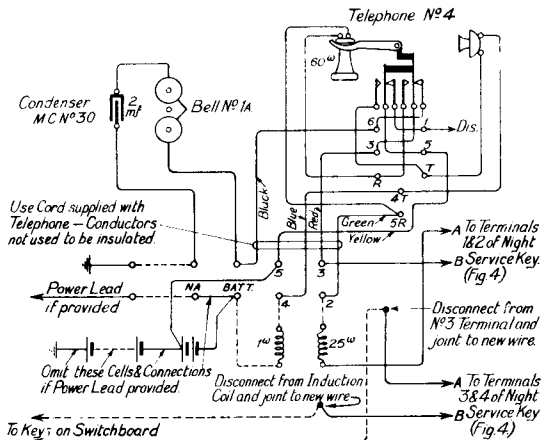

FIG. 3. TYPICAL TELEPHONE AT EXTENSION HAVING NIGHT SERVICE.

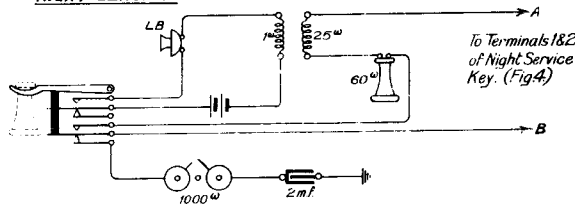

FIG. 4. NIGHT SERVICE KEY.

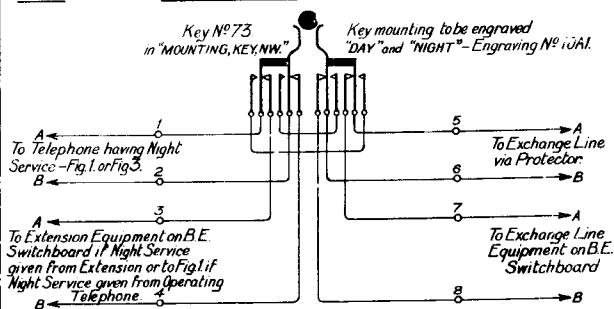
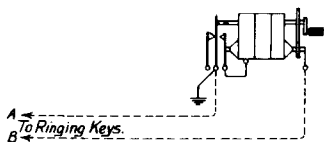

FIG. 2. SWITCHBOARD GENERATOR WHEN NIGHT SERVICE REQUIRED FROM EXTENSION.



NOTES. 1. Dotted Lines represent Normal Connections of Switchboard.

R.I. and Tracing Dilapidated

AMENDMENT

W