

TELEPHONE No 713

PENDANT TELEPHONE WITH PROVISION FOR ONE PRESS BUTTON FOR USE ON CB AND AUTO SYSTEMS

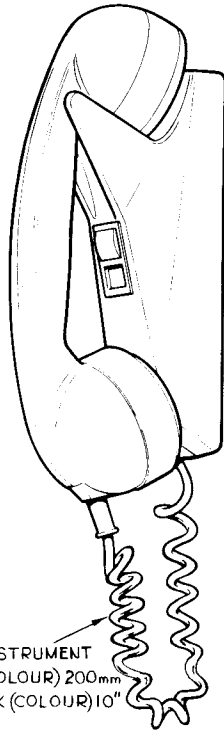

AUXILIARY FITTINGS TO BE REQUISITIONED SEPARATELY

GRAVITY SWITCH SPRINGSET
PART 1/DSP/1279 (NOTE A)

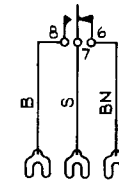

PUSH BUTTONS (NOTE B)

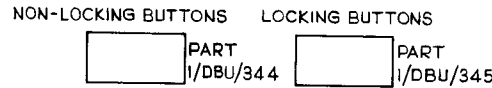

PRESS BUTTON SWITCH
SWITCH No. 5A-7

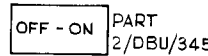
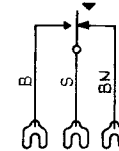
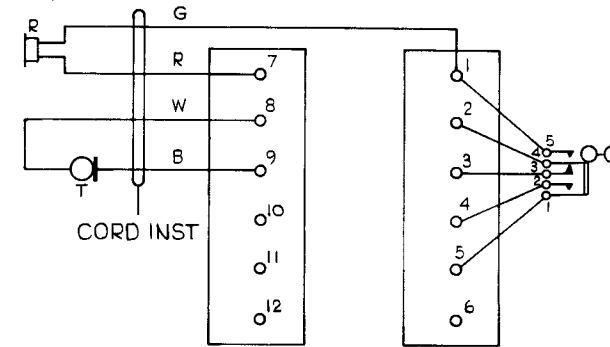

FIG.1 CIRCUIT DIAGRAM
SHOWING CONNEXIONS AS ISSUED.



NOTES:-

A. THE SPRINGSET IS SHOWN WITH THE CONTACTS IN THE CONDITION AS ISSUED. WHEN FITTED TO THE TELEPHONE, THIS IS THE CONDITION WITH THE HANDSET REMOVED.

B. BUTTONS CAN BE ENGRAVED AS REQUIRED BY SUBMITTING A REQUISITION (A1097) WITH ENGRAVING PARTICULARS(A1098) TO THE FACTORIES DEPT. CWMCARN

CONTENTS:-

| | | |
|--|--------|--------|
| CIRCUIT DIAGRAM SHOWING CONNEXIONS AS ISSUED | FIG. 1 | PAGE 1 |
| DIRECT EXCHANGE LINES | FIG. 2 | PAGE 2 |
| SHARED SERVICE LINES | FIG. 3 | PAGE 2 |
| 2-WIRE PBX EXTENSION WITH RECALL | FIG. 4 | PAGE 3 |
| PMBX WITH ADDITIONAL SIGNALLING C-WIRE | FIG. 5 | PAGE 3 |
| INTERNAL EXTENSION, PLAN 107 | FIG. 6 | PAGE 4 |
| BUZZER No.32C-3 FITTED IN BELL-SET No. 50B | FIG. 7 | PAGE 4 |

REFERENCES

TELECOMMUNICATIONS INSTRUCTIONS C MARKETING INSTALLATION AND E MAINTENANCE
3 INTERNAL B 1010 5 STATIONS B 2658

AUXILIARY UNITS AND ADDITIONAL PARTS FOR 700 TYPE TELES N4700

GENERAL NOTES:-

- FOR CB SYSTEM OR WHEN DIALLING FACILITY IS NOT REQUIRED OMIT MOUNTING DIAL AUTO No.21 AND STRAP TERMINALS 8 AND 10 IN BELL-SET
- WHEN AN EXTENSION BELL IS REQUIRED, CONNECT IN PLACE OF STRAP BETWEEN TERMINALS 17 & 18 IN BELL-SET (14 -15 IN FIG 3)
- SWITCH No. 5A-7 CAN BE EITHER A NON-LOCKING SWITCH BY USING A PART 1/DBU/344, OR LOCKING BY USING A PART 1/ OR 2/DBU/345.
- ADDITIONAL TERMINALS CAN BE PROVIDED
 - 6 IN THE TELEPHONE, USING PART 2/DST/836
 - 6 IN THE BELL-SET No.48 USING PART 2/DST/836 AND PART 1/DBR/442
 - 6 OR 12 IN THE BELL-SET No. 50B BY USING 1 OR 2 PARTS 2/DST/836

| | | | | |
|---------------------------|-------|---|--------------------------------------|----------------------------|
| P.O. TELECOMMS HQRS | ISSUE | | | |
| | | D | FIGS. 2 & 6 AMENDED. <i>apb</i> | TD7.1.3 8-2-78 |
| | | C | REDRAWN DGM. N4699 INCORPORATED | <i>DBU</i> TD7.1.1 22-5-75 |
| | | B | REVISED FORM. NOTES REWRITTEN F.J.H. | 13-1-66 |

FIG. 2 DIRECT EXCHANGE LINES

EXPLANATORY

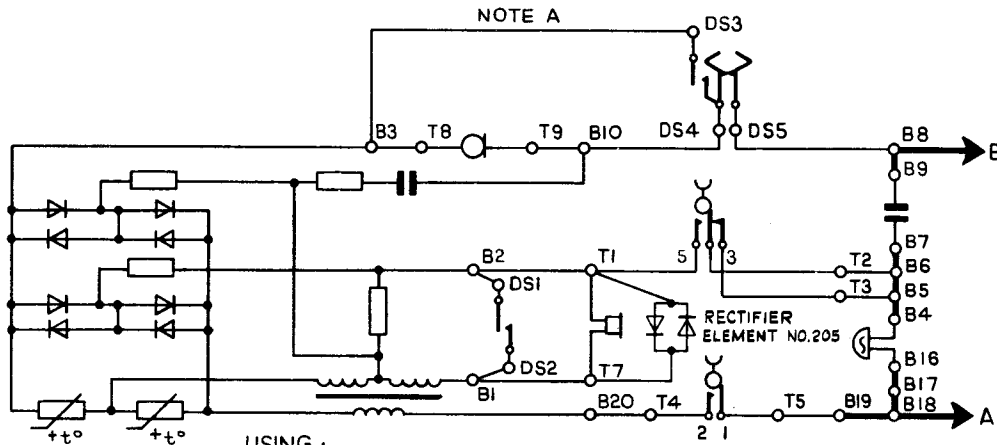

USING :-
TELEPHONE No. 713
BELL-SET No. 48 OR No. 50B
MOUNTING DIAL-AUTO No. 21

NOTE :-
A. ON EARLIER ISSUES DS3 WAS
CONNECTED TO B20 INSTEAD OF B3

WIRING

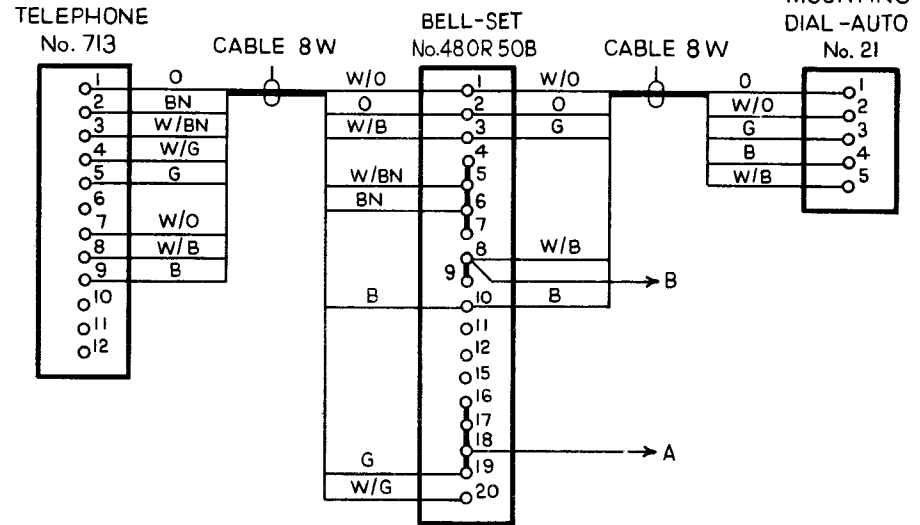
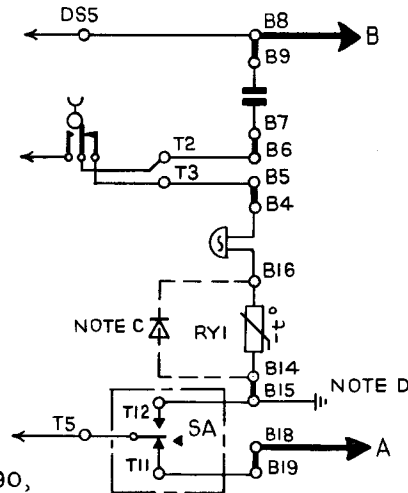

FIG. 3 SHARED SERVICE LINES

EXPLANATORY

USING :-
TELEPHONE No. 713
BELL-SET No. 48 OR 50B
MOUNTING DIAL-AUTO No. 21
SWITCH No. 5A-7 (SA)
PART 1/DBU/344
THERMISTOR No. IA-1 (RY1) NOTE C

NOTES :-
A. REMOVE STRAPS B5-B6, B16-B17.
SHIFT STRAP B17-B18 TO B14-B15
B. EXCHANGE LINE CONNEXIONS
'A' WIRE TO B8 } STATION X
'B' WIRE TO B18 }
'A' WIRE TO B18 } STATION Y
'B' WIRE TO B8 }
C. IN U.A.X. AREAS WITH VIBRATOR RINGING
PROVIDE AND FIT VALVE ELECTRONIC CV8790,
CV7875 OR CV8805
D. AN EXTENSION BELL MAY BE CONNECTED IN PLACE
OF STRAP B14 - B15



WIRING

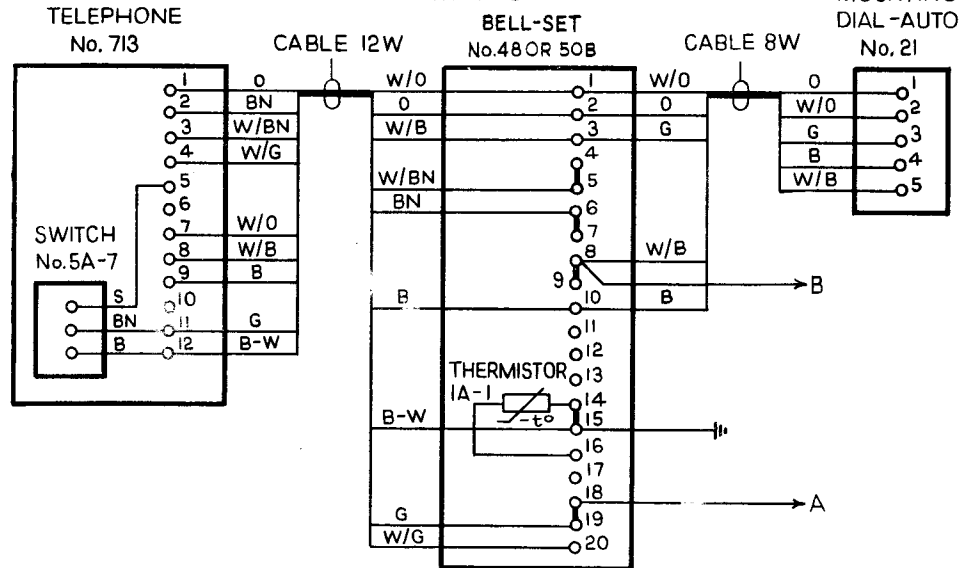
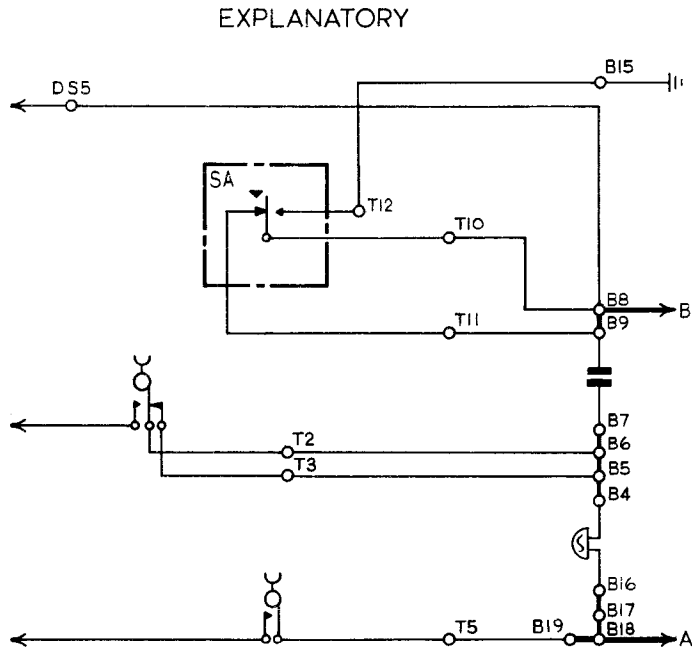

FIG 4
2 WIRE PBX EXTENSION WITH RECALL



USING:-

- TELEPHONE No.713
- BELL - SET No.48 OR No.50B
- MOUNTING DIAL AUTO No.21
- SWITCH No.5A-7 (SA)
- PART 1/DBU/344

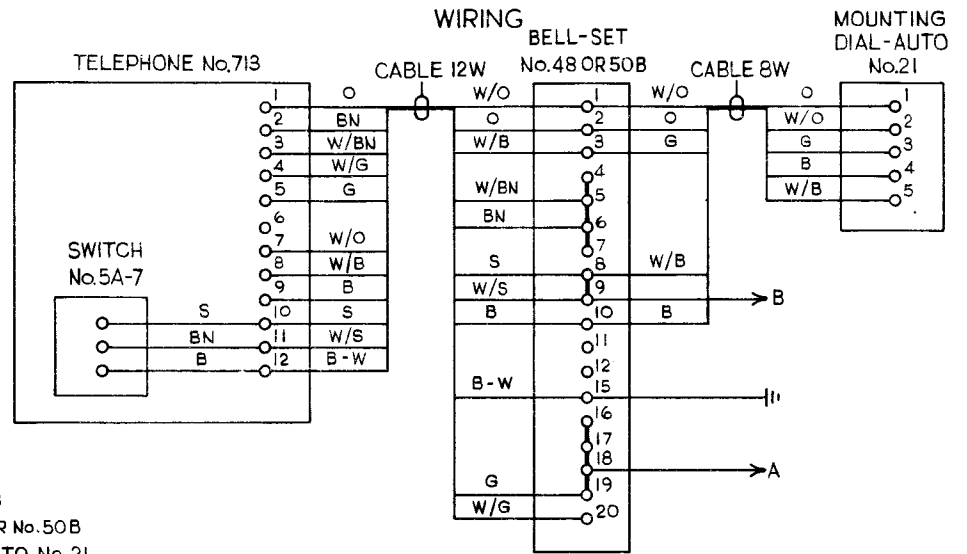
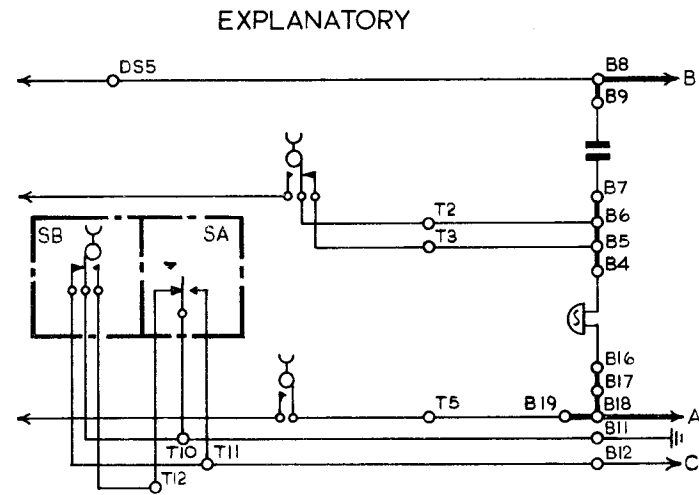

FIG 5

PMBX WITH ADDITIONAL SIGNALLING C-WIRE



USING:-

- TELEPHONE No. 713
- BELL-SET No.48 OR No.50B
- MOUNTING DIAL-AUTO No.21
- SWITCH No.5A-7(SA)
- PART 1/DBU/344
- PART 1/DSP/1279(SB)

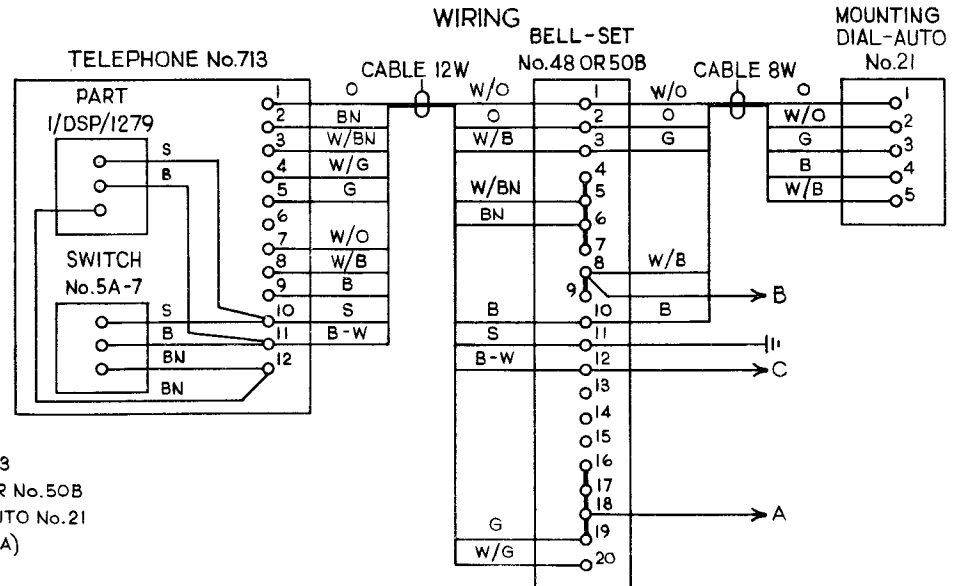

NOTE :- FOR TWO WIRE EXTENSIONS USING UAA No.96 OR 96A,
WIRE THE TELEPHONE AND BELL SET TO FIG 4.

FIG 6

INTERNAL EXTENSION PLAN 107

EXPLANATORY

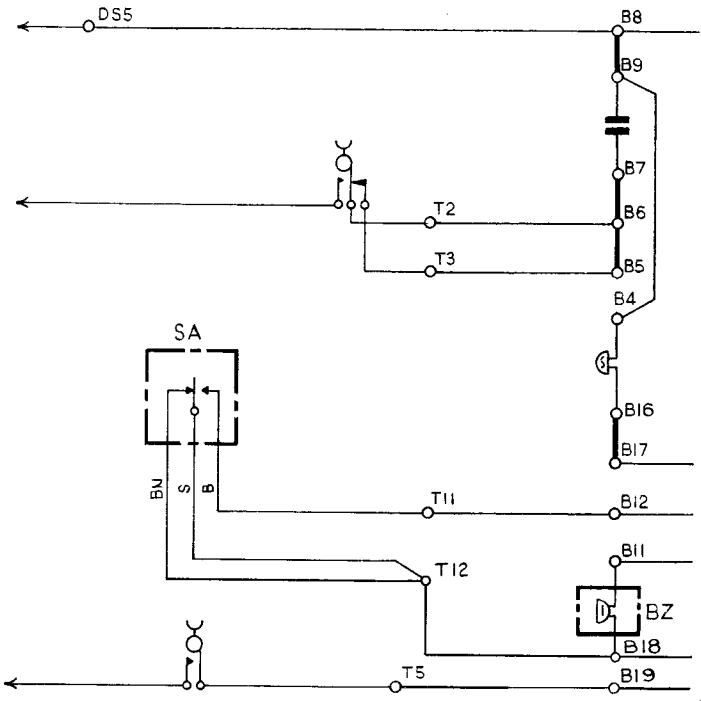

USING :-
TELEPHONE No. 713
BELL-SET No. 48
PART 1/DBR/442
BUZZER No. 32c-1 (BZ)
SWITCH No. 5A-7
PART 1/DBU/344

ALTERNATIVELY USING :-
TELEPHONE No. 713
BELL-SET No. 50B
BUZZER No. 32C-3 (BZ)
SWITCH No. 5A-7
PART 1/DBU/344

NOTE :-
A. REMOVE STRAPS B4-B5, B16-B19,
B17-B18 AND PROVIDE WIRE
STRAP B4-B9

WIRING

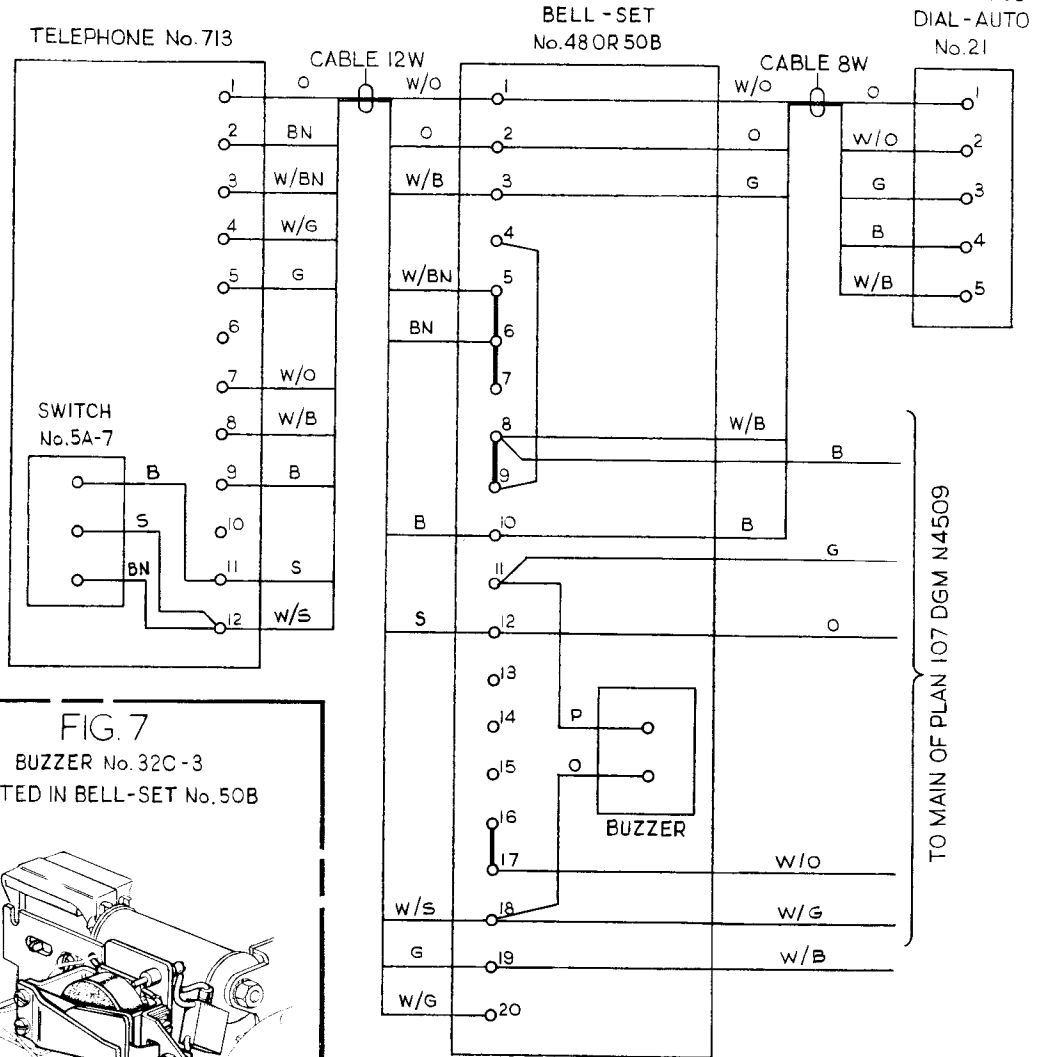

TO MAIN OF PLAN 107 DGM N4509

TO MAIN OF PLAN 107 DGM N4509

