

TELEPHONE No.702 MK III NOTE 9

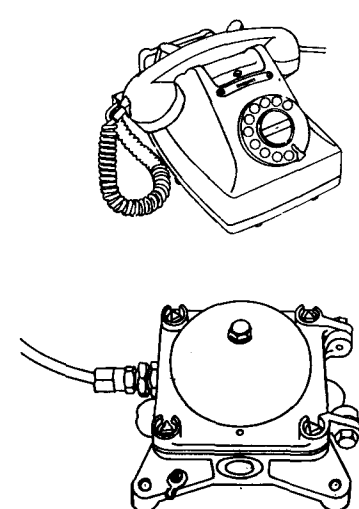
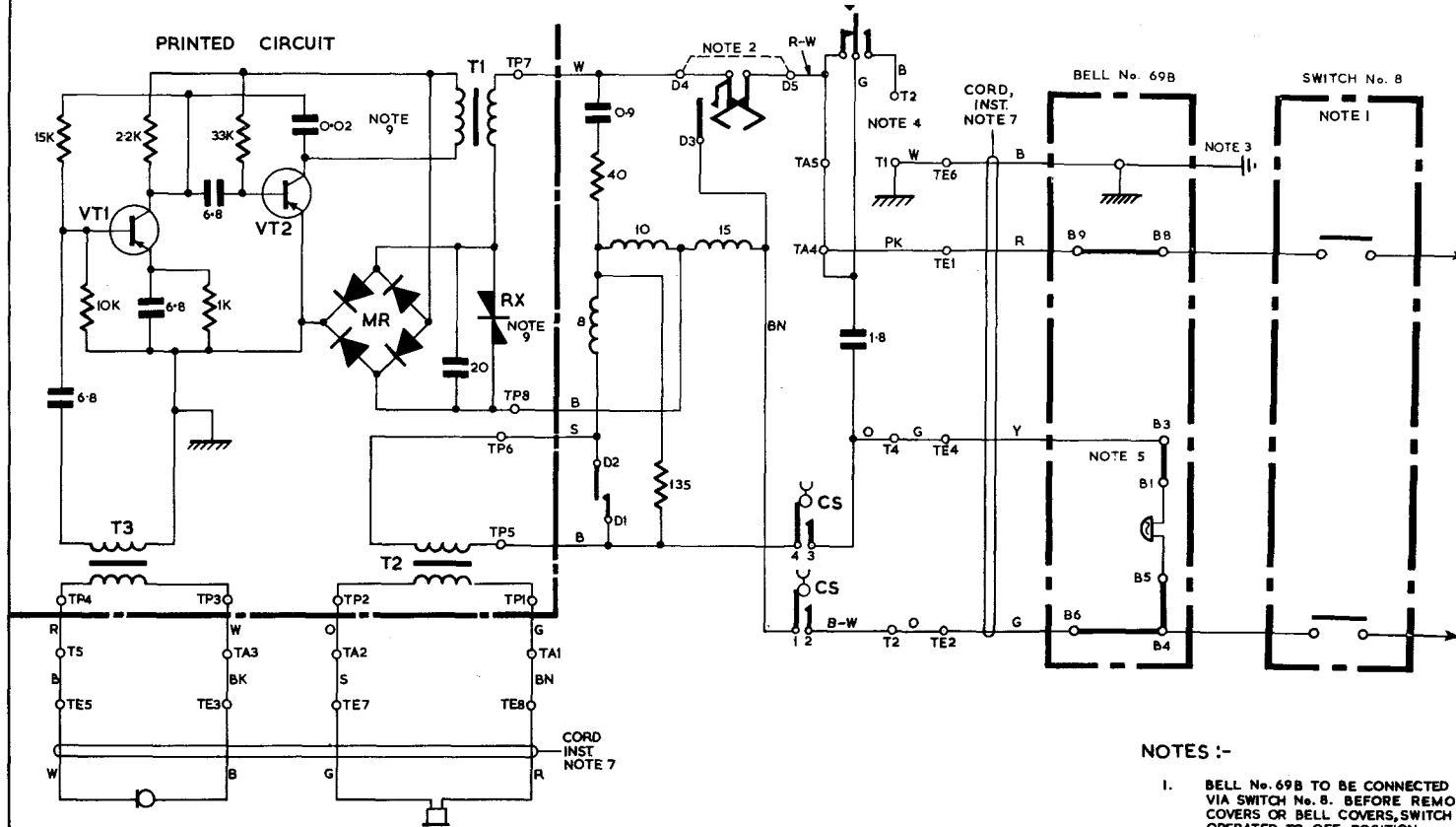

NOTES :-

1. BELL No. 69B TO BE CONNECTED TO THE LINE VIA SWITCH No. 8. BEFORE REMOVING TELEPHONE COVERS OR BELL COVERS, SWITCH No. 8 TO BE OPERATED TO OFF POSITION.
2. ON C.B. SYSTEMS, LOCK DIAL BY REPOSITIONING SCREW IN FLY BACK MECHANISM AND CONNECT STRAP D4-D5
3. THE FRAME AND SIGNALLING EARTH IS OBTAINED VIA THE METAL CONDUIT OR SHEATH, CONNECTED INTO THE BELL TERMINAL UNIT
4. FOR ENQUIRY FACILITY ON P.A.B.X'S No.12 & 3 CONNECT STRAP T1 TO T2, ON P.M.B.X'S CONNECT STRAP T1-T2, AND REMOVE STRAP TA4-TA5.
5. WHEN AN EXTENSION BELL IS REQUIRED, CONNECT IN PLACE OF STRAP B1-B3
6. TERMINALS DESIGNATED TE ARE FITTED IN THE ENCLOSURE AT THE REAR OF THE CASE
7. LINE CORD, HANDSET CORD AND DIAL MECHANISM OBTAINABLE FROM MESSRS. ERICSSONS
 HANDSET CORD - N 9622
 LINE CORD - N 4957
 DIAL MECH. - N 81634
8. BELL 69B MUST BE MOUNTED WITH THE HINGE ON THE LEFT HAND SIDE.
9. IN MK. I MODEL, RX WAS 68Ω, O-O2 WAS O-O4 IN SERIES WITH 15KΩ. IN MK II MODEL O-O2 WAS O-O4 IN SERIES WITH 15KΩ.

P.O.
 TELECOMMS.
 HQRS.

PAPER : W

CIRCULATION :
 GENERAL

ISSUES		
C	TELE. 702 MK. 4, PAGE 2 ADDED.	12.11.68
B	VT1b RESISTOR NOW 15K AND CONNECTED TO CAPACITORS.	5.5.67
A	REVISED FORM. TELE No. 702 MADE MK III. NOTES B & 8 ADDED.	12.6.65
-	F.E.L.T. TDI.4.1. SECTION	4-10-61

TELEPHONE No.702 MK.4.

