

TERMINATION OF INTERSWITCHBOARD PRIVATE CIRCUIT

SWITCHBOARD AT3796 & SWITCHBOARD N1070
SIGNALLING GROUP D G/AC IN; G/AC OUT

N 726
2 PANELS-1
17-6-55
SUPERSEDES FOR NEW
WORK N985, FIG. 4 (F)

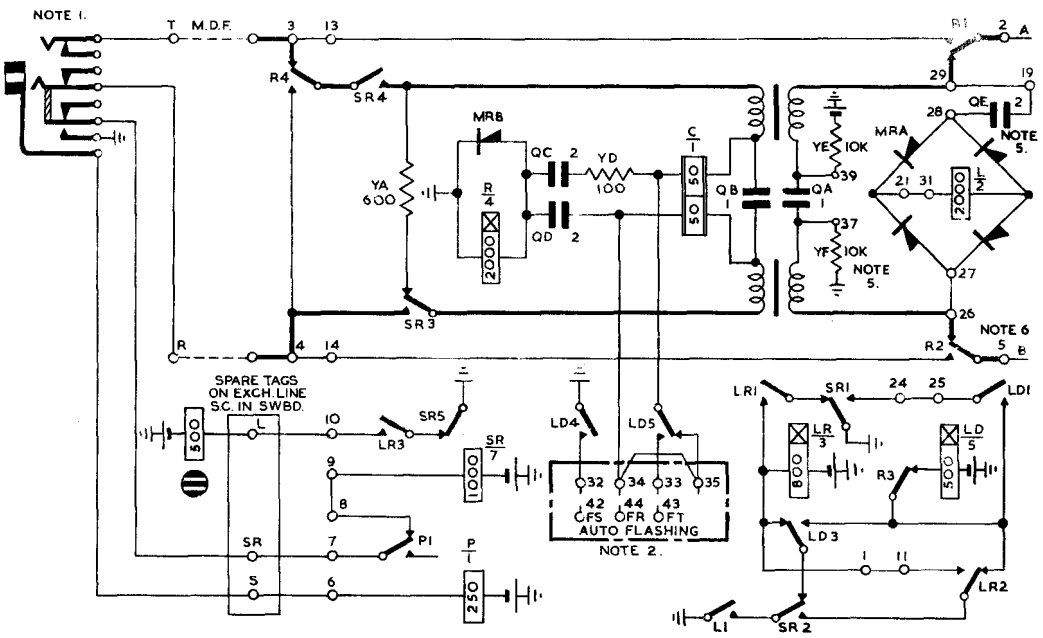

N726

2 PANELS-2

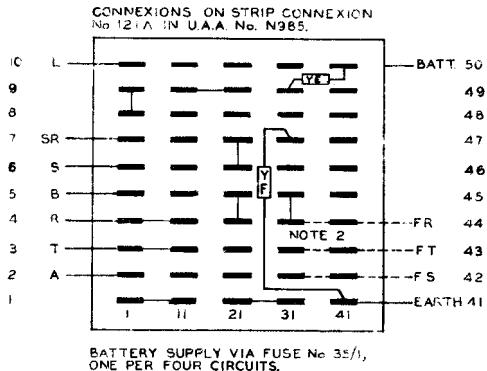

NOTES :-

1. WHEN NECESSARY FIT JACK No.710 B0 IN PLACE OF EXISTING JACK No.510 BS ON 65 LINE SWITCHBOARDS & JACK No 610 BN IN PLACE OF EXISTING JACK No.510 B0 ON 180 LINE SWITCHBOARDS.
2. WHERE SUPERVISORY FLASHING FACILITIES ARE TO BE PROVIDED. STRAP 32-42, 33-43 & 34-44. CONNECT AS SHOWN N990 FIG 2
3. SEE N1093 FOR REVERSAL OF GENERATOR LEADS ON SWITCHBOARD AT 3796.
4. EXPLANATORY DIAGRAM SHOWING CHANGES TO JACK & INDICATOR PERMANENT WIRING IS GIVEN IN N727 PANEL 2.
5. QE & WETTING RESISTORS TO BE REQUISITIONED SEPARATELY, CAPACITOR MC. No.102 & CLIP No.42, RESISTOR CARBON No.110K
6. LINES NORMALLY REVERSED AT ONE END ONLY.
7. WHEN REQUIRED BATTERY SUPPLY TO UNIT MAY BE TAKEN VIA A SPARE NIGHT SERVICE KEY.