

WIRING DIAGRAM

EXPLANATORY

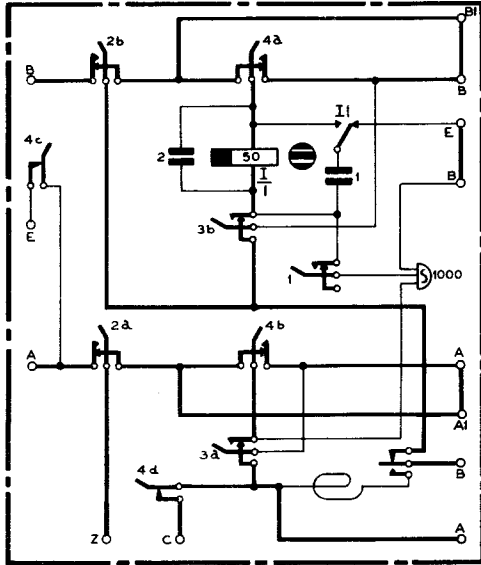

SWITCH POSITIONS. ALTERNATIVE ENGRAVING

- |                              |                            |
|------------------------------|----------------------------|
| 1. MAIN TO EXCH.             | SPEAK TO EXCH.             |
| 2. MAIN TO EXTN. EXCH. HELD. | SPEAK TO EXTN. EXCH. HELD. |
| 3. MAIN TO EXTN.             | SPEAK TO EXTN.             |
| 4. EXCH. TO EXTN.            | EXTN. TO EXCH.             |

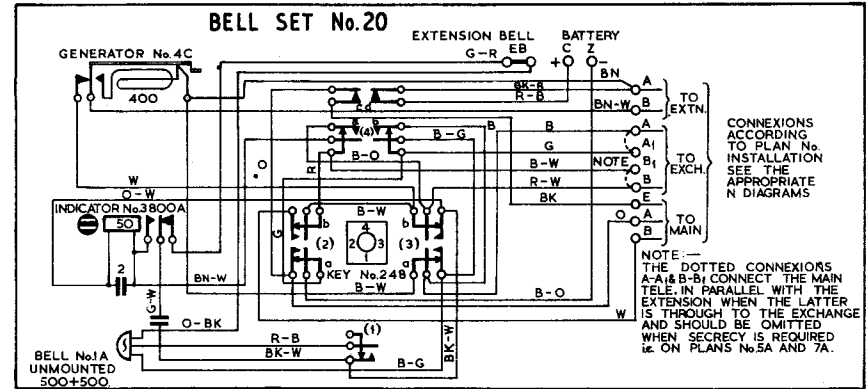
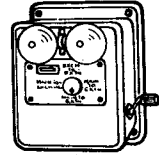

THE ABOVE WIRING DIAGRAM IS FOR MK1,2,3 AND EARLY SUPPLIES OF MK 4 BELL SET.

NOTE

For connexions of extension plans Nos.5,5A,7 & 7A see appropriate N diagrams.

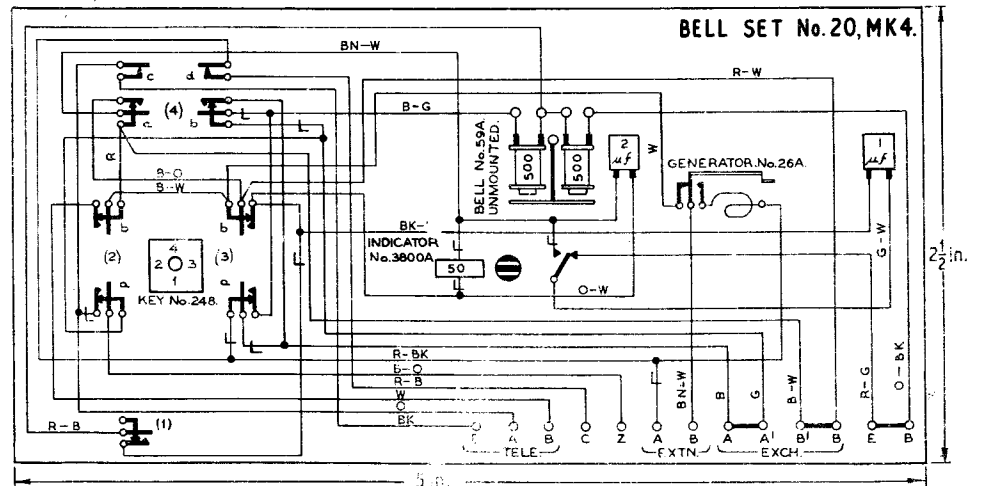

THE LABEL DIAGRAM TO BE REDUCED TO DIMENSIONS GIVEN.

P.O.E.D. S BCH.			
PAPER: W			
CIRCULATION	H	New format.	5-1-68
GENERAL	G	Made 4 panels.	3-11-54
		E.L.S. E.S.R. SI/1/1	25-9-25

SWITCHING CONDITIONS

EXPLANATORY

