

N221

A.I. 1728. LL'S. 24.

TELEPHONE N<sup>o</sup>-121. (Mark 234)

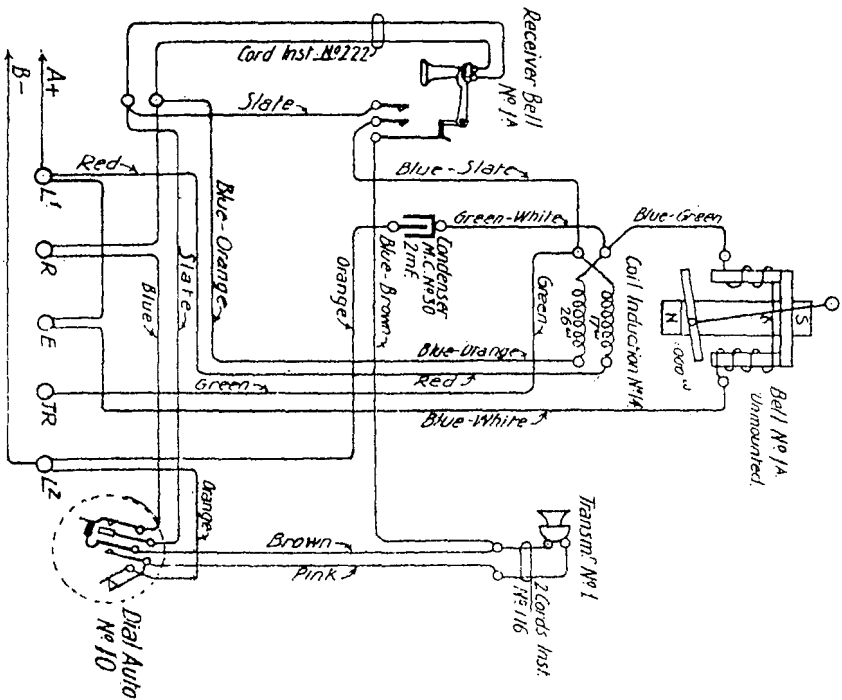

# TELEPHONE N°121 C.B. (Mark 234)

N.221.

25-11-29  
Panel 1.

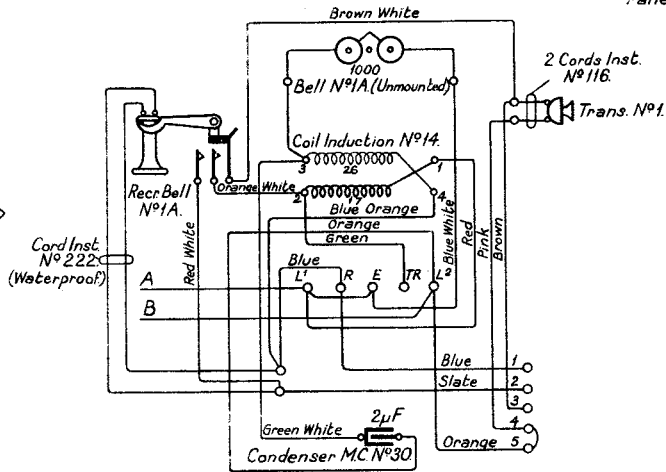
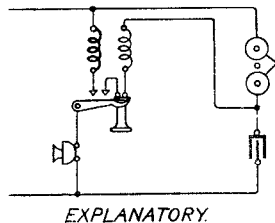
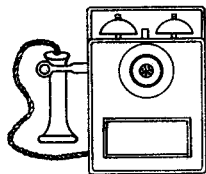

Notes:-

- (1) Remove strap between terminals L' & E when Extension Bell is Fitted
- (2) For conversion to Automatic working, remove Frame Notice N°1. Instruction Card and dial aperture cover; fix Mounting, Dial, Automatic N°7; remove strap between terminals 4 & 5; fit Dial Automatic N°10... and connect as shown for Telephone N°121, Diagram AT 1728. (N 221). Remove Label N°43 and, where necessary, fit Label N°43C.

copy copy

CB & A  
 15 5 56  
 22 8 24  
 22 8 24  
 COIL INDUCTION No. 18. WAS No. 14.  
 REGRAN. NEW DESIGNATION TEL. 2 DIAL STRIPS. NOTES ADDED.  
 RED WIRE FROM XAMTS TO DIAL CONN. PLATE WAS SHOWN FIN.

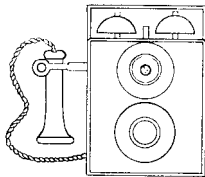

# TELEPHONE N°121... (MARK 2)

FOR USE IN CB & AUTO SYSTEMS

N221

2. PANELS-1  
 22-8-24

SUPERSEDES FOR NEW WORK  
 N201 & N101  
 SUPERSEDES TELE. N° 105

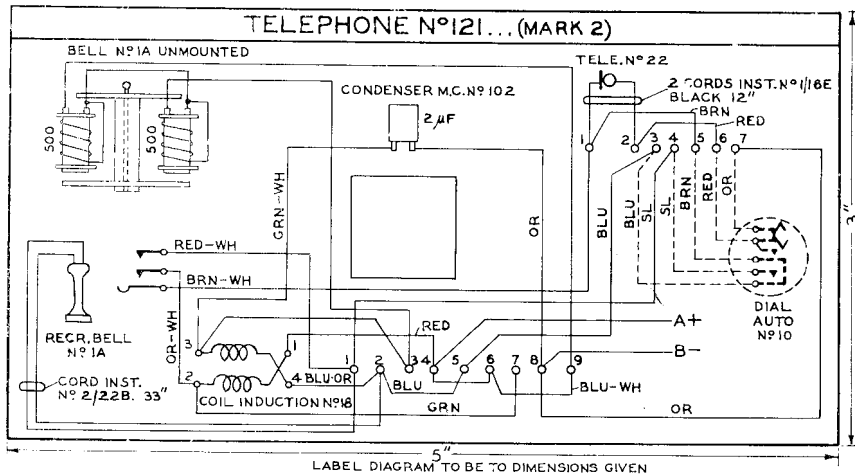

NOTES:-

- EARLY ISSUES OF TELE. 121 HAD LETTERED CONNEXION POINTS WHOSE EQUIVALENTS ARE  
 TELE STRIPS.  
 1 2 3 4 5 6 7 8 9  
 REC. L<sub>1</sub> R<sub>1</sub> ETR L<sub>2</sub>  
 TERMINALS 3 & 9 CONNECTED TO BELL CONNEXIONS.  
 DIAL STRIP  
 1 2 3 4 5 6 7  
 T 1 2 3 4 5
- REMOVE STRAP BETWEEN TERMINALS T4 & T6 WHEN EXTENSION BELL IS FITTED.

# N221

2 PANELS-2

## EXPLANATORY

FOR CB WORKING DIAL  
NOT FITTED. D6 AND  
D7 STRAPPED

⊗ DIAL SPRINGS

T TELE. STRIP

D DIAL STRIP

