

**POST OFFICE**

*tele* **communications**

**JOURNAL**

ONE SHILLING

AND

SIXPENCE

AUTUMN 1963

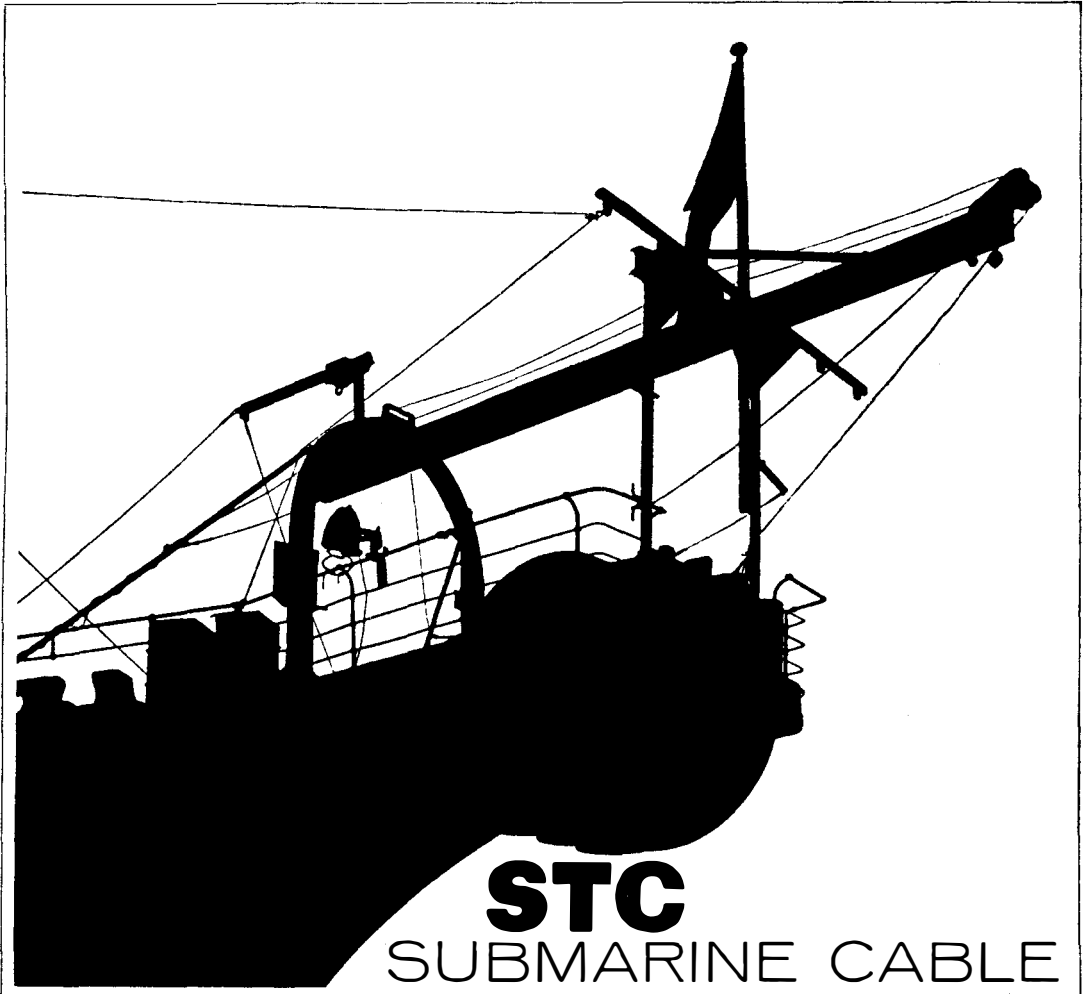

# STC SUBMARINE CABLE

Chosen for underwater communications systems all over the world

Submarine telephone cable on order or already manufactured at the STC Southampton factories:

<i>UK—USA (TAT3)</i>	3 600	<i>UK—Germany No 2</i>	253
<i>Commonwealth Pacific Cable</i>	2 800	<i>UK—Germany No 1</i>	250
<i>USA—Bermuda</i>	820	<i>Bournemouth—Channel Islands</i>	140
<i>Scotland—Faeroes—Iceland</i>	750	<i>UK—Holland</i>	115
<i>Puerto Rico—Florida</i>	715	<i>Wales—Isle of Man</i>	66
<i>UK—Sweden</i>	536	<i>UK—Belgium</i>	61
<i>UK—Denmark</i>	315		

(all distances in nautical miles)

STC engineer and manufacture all types of submarine telephone and telegraph cable



*Standard Telephones and Cables Limited*

**SUBMARINE CABLE DIVISION:**

NEW DOCKS · SOUTHAMPTON · HANTS



These Advanced Features give the Vanguard **EXTRA PERFORMANCE**  
UNIT PRINTED BOARD CIRCUIT ELEMENTS

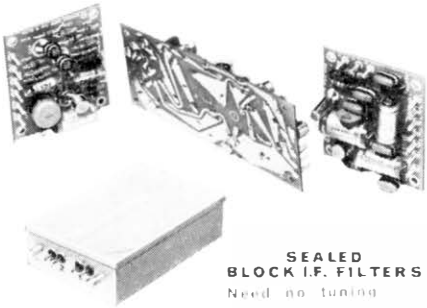

SEALED  
BLOCK I.F. FILTERS  
Need no tuning



INTRODUCE THE  
**VANGUARD**  
A Magnificent

25-Watt Transistorised  
**RADIOTELEPHONE**

**ONLY the VANGUARD has ALL these qualities**

- 25/30 & 50/60Kc/s channels
- Extensively Transistorised
- Sealed Block I.F. Filters
- Printed Circuitry
- Very low Battery Drain
- All Aluminium Construction
- Dust-proof and splash-proof
- One—Six Channels
- 25 Watts Output
- Very low-noise Receiver
- High Stability Mute
- 4 Watts Audio Output

Meets British, American, Canadian and Continental Specifications

**PYE TELECOMMUNICATIONS LIMITED . . . CAMBRIDGE**

TELEPHONE: TEVERSHAM 3131



# type 174

## small diameter coaxial cable specially designed for use with transistor amplifiers

Small diameter coaxial cables have now become an established medium for the provision of long distance high grade telephone circuits. Coupled with underground transistorised amplifiers, this type of cable is rapidly finding increased use amongst telephone administrations throughout the world as the most economical method of providing groups of trunk telephone circuits.

Telephone Cables Limited have developed their own design of small diameter .174 Coaxial Tube to meet the recommendations of the C.C.I.T.T. and the requirements of the British Post Office. The cable has been fully tested and approved by the British Post Office and cables of this design, manufactured and installed by T.C.L., are now in hand for supply and installation in the United Kingdom and overseas.

*Fullst technical details of Type 174 Coaxial Cable gladly supplied by return.*

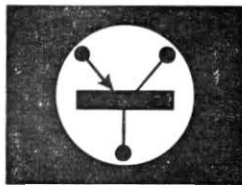

# TCL

## TELEPHONE CABLES LIMITED

Dagenham, England. Tel: Dominion 6611 Cables; Drycore Dagenham  
THE ORGANISATION WITH 125 YEARS' EXPERIENCE

# Post Office Telecommunications Journal

*Published by the Post Office of the United Kingdom  
to promote and extend knowledge of the operation  
and management of telecommunications*

## *Contents*

### THE TAUNTON EXPERIMENT

R. P. Dick

*page 2*

### THE YEAR GONE BY . . .

*page 7*

### NEW SWITCHBOARDS SPEED OVERSEAS TELEX CALLS

M. V. Abbott and K. C. J. Hill

*page 10*

### MORE FOR THE MONEY

A. H. Ridge

*page 15*

### THEY HELP TO PUT THE PICTURES ON YOUR SCREEN

A. G. Hickson

*page 20*

### CURING THE LEAKS IN LOCAL CABLES

J. F. Keep

*page 25*

### LONDON'S TRUNK SWITCHING UNITS

S. R. Valentine

*page 32*

★

## *An Excellent Beginning*

**T**he Post Office campaign to encourage people to make more trunk telephone calls in the cheap-rate periods and more local calls at all times has, to judge from the newspapers, captured the public imagination.

The campaign is being conducted through the media of television, the Press, posters and leaflets and will cost about £250,000 during the year it is scheduled to run. It is the most ambitious the Post Office has carried out to attract more business. Never before has the Post Office advertised on television and never before have the many advantages of the telephone been brought home to such a large audience.

Much, of course, has already been done—particularly through the various Information Services which last year attracted over 110 million calls—to stimulate business and to make the public more telephone minded. But more will have to be done if subscribers are to be persuaded to exploit all the benefits the telephone offers and so enable the Post Office to improve and expand the service.

The average number of calls made by telephone subscribers in this country at present compares unfavourably with those in many other countries. To improve this situation every effort must be made to inform the public of the many valuable advantages of the telephone. This new advertising campaign is an excellent beginning.

In a recent speech at the opening of the Recipe Service in Manchester and Liverpool the Postmaster General said that the telephone was the quickest, easiest and cheapest method of meeting people. It saves time, money and trouble. For a rental of only five shillings a week a subscriber has at his disposal a system costing more than £1,000 million which can put him in touch with 150 million more telephones throughout the world.

These words could bear a lot of repetition.



# THE TAUNTON

Rapid developments are taking place in the search by the Post Office for cheaper and quicker techniques for printing telephone directories. This article describes the successful trial carried out in Taunton with a system which involves the use of typed cards and high-speed photography



**THE OLD**  
Casting lines of metal type on an Intertype machine. Each machine has four magazines, each holding 90 matrices.

**L**AST November when some 50,000 subscribers in the Taunton telephone area received their new telephone directories they noticed no great difference in their appearance. Indeed, today, nine months later, there is so little comment that in spite of much local publicity, the change which took place seems to have passed completely unnoticed. This is significant. It seems that our customers have given the label of success to a revolutionary change in the method of printing these books.

This success in Somerset in 1962 was the end of the story. The beginning was much earlier.

The Post Office publishes more telephone directories than any other administration in Europe—including Soviet Russia. Each year 12,000,000 roll off the presses at the Stationery Office's printing works in Harrow, Middlesex. Copy for them is provided by the staff in Telephone Managers' offices, usually in the form of amended columns of the directory for the previous year.

This method is simple, reliable and cheap. At the printers, strips of lead known as slugs are produced from *Intertype* machines for each new line and compositors interpolate these in the type held for the previous directory. At the same time the slugs for ceased entries are withdrawn. Proofs of the

# EXPERIMENT



By R. P. DICK

columns are checked by the Telephone Manager's staff and when the pages are made up with advertisements and so on they are checked by the printer's readers. Curved metal plates—or stereotypes—are produced from the pages of type—one plate for

## THE NEW

Miss P. J. Densum types a card for the Taunton directory. Note the special platen for holding the cards.



two pages—for assembly on the huge rotary machines. These machines are similar to those used for large-circulation newspapers and are fed from reels of paper each weighing nearly half a ton. The pages are printed at the rate of 16,000 a minute on each machine and are then ready to be made into books.

This last process is more complicated than that in the newspaper world, the machine collating, binding and trimming the pages to turn out 6,000 finished books an hour. This method of printing—called letterpress—probably represents the peak development of printing from relief surfaces, invented over 1,000 years ago, with moveable type

introduced to Britain in 1476. It has endeared itself to printers for its great flexibility and economy.

Letterpress printing is being increasingly challenged by lithography because of the facility of incorporating photographic techniques which the latter system offers. In simple terms, this means that original copy can be photographed and a printing plate made from the negative so that in theory, at least, the need for metal type and for some of the composition and proof reading is eliminated. Lithography has made inroads into some traditional letterpress fields but so far big-circulation newspapers and books have not been greatly affected.

OVER



### THE OLD

The curved stereo plates of telephone directory pages ready for fixing to the rotary press.

### THE TAUNTON EXPERIMENT (Contd.)

Since World War Two a number of systems have been developed which could be used for printing telephone directories. Most of them follow the same principle: the text is typed on cards, the cards are photographed and a printing plate is made from the film. Among the best known processes are *Flexoprint* and *Cartoprint*, in which the typed cards are manually inserted into metal frames or strips, and *Fotolist* and *Listomatic* the names of high speed cameras into which typed cards are automatically fed. The Post Office already has a large *Flexoprint* unit at Glasshouse Yard, near GPO Headquarters in London, which, among other things, prints relatively small runs of telephone directories for internal purposes. (The German Post Office recently chose this method for printing its public directories). *Cartoprint* is used by one of the Stationery Office's contractors who print the small local directory for Woking, Surrey. Some of the small directories in the United States have been produced by *Listomatic* or *Fotolist* and the Dutch administration has gone over entirely to *Listomatic*.

The Stationery Office and the Post Office have kept in constant touch about these new developments and early last year decided to carry out a live trial with the Taunton directory by processing one half of the book by the *Listomatic* and the other half by the *Fotolist* system.

In view of the successes achieved in other countries, why was the Post Office not able to judge which of the four or more systems offered the greatest advantages and change over accordingly? There are three answers. First, only the Americans have the same problem in terms of size and circulation which the Post Office has with, say, the London directories and they have also found that the advantage lies with the lead type and letterpress method. Second, the Post Office saw the possibility of a better combination of methods than those tried hitherto. And third, conditions in the printing trade are not the same in all countries.

The first decision which had to be made at the outset of the trial was which typewriter to employ. At first sight the choice was between the *Justewriter* which gives left and right hand alignment and is usually associated with *Listomatic*, and the *Vari-*

Gray's Almshouses, East st .....	Taunton ..	81645
<b>GRAY'S CAMERA SHOP,</b>		
(Retail), 1 St James st .....	Taunton .....	2986
Grays Bookshop, 1 St James st .....	Taunton .....	2986
Grayson A. B., Chrt'd Arch, Hill ho .....	Wincanton ..	3355
Grayson Robt., Lennybarn Over Stratton ..	S Petherton .....	200
Grayston J., Auton Idg .....	Milverton .....	242
Gready A., Bodley fm Ford st .....	Wellington ..	2603
Gready E. F., 136 Bridgewater rd Taunton	W Monkton ..	379
Gready Hy. J., Ivy ho .....	Henlade .....	281

Twist O, Highfield Weeth rd .....	Camborne	3242
Twist R. A., Woodland cott Mitchell hi .....	Truro	3656
Twitchett C. F., 34 Priory dr .....	Plympton	3616
Twivey H. F., Glenbank Falmouth rd .....	Truro	2981
<b>TWO BRIDGES HOTEL, (Management) .....</b>		
(Visitors) .....	Princetown	206
	Princetown	220
<b>TWO CHIMNEYS CARAVAN PARK, Prah Sands ..</b>		
Two Parks Stores, Wines, Spir, Plymstock rd ..	Germoe	3215
	Plymouth	41288
Two Quays Flats, Gweek .....	Mawgan	602
Two Trees, Union st .....	Plymouth	68727
Twohig Rev. J. M., Walton Leigh .....	Salcombe	2683

Above (left) part of a page of the Taunton directory set in Registry type face and (right) of the present Plymouth directory set in Bell Bold type face.



## THE NEW

**Making the relief  
plate for pages  
of the  
Taunton directory.**

—Courtesy: V.  
Siviter Smith,  
Birmingham.

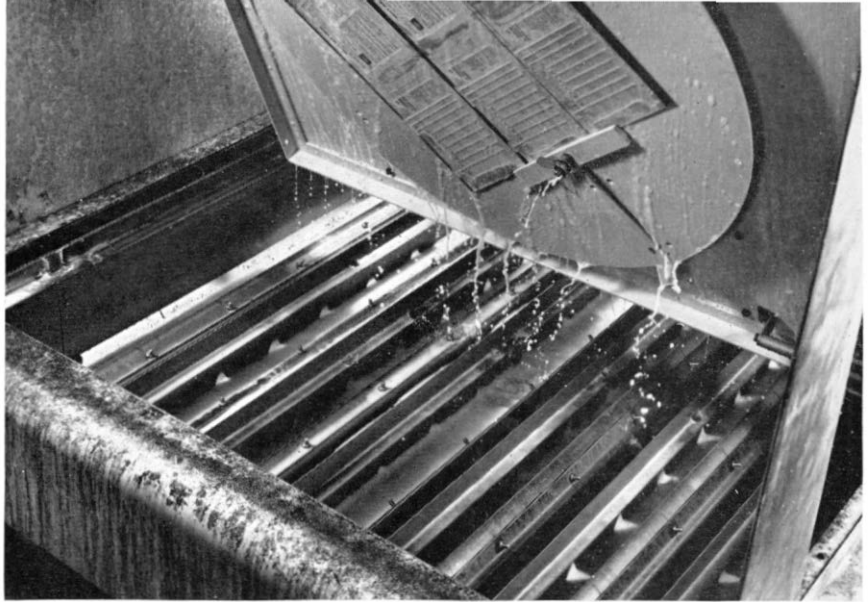

*typer*, which gives light and heavy type entries and is usually associated with *Fotolist*. It was decided, however, that by altering the form of the entries and reducing the incidence of variation in light and heavy type, an electric typewriter which is less costly and much faster should be used.

In practice, the very critical registration needed for the *Fotolist* camera could not be achieved on the typewriter in time and all the cards therefore were photographed by *Listomatic*. (A suitable platen for *Fotolist* cards which overcomes this difficulty has since been produced). It was also found that to get an acceptable standard of heavy and light lines in the time available, they had to be typed separately. (This, too, should be remedied in the very near future). Difficulty was encountered, as expected, in ensuring that the typing was well positioned in relation to the top and left hand edges of the cards—a prerequisite to good alignment in the printed columns. In the event this was largely overcome by checking each card in a gauge.

The cards were processed through the *Listomatic* camera at the rate of 230 a minute. This is faster than by the *Fotolist* system which, however, would have given more lines to a column, an important consideration with big directories where paper accounts for two-thirds of the cost.

Making a plate for lithographic printing from the film would have been relatively simple but it was decided to convert to a relief plate for the letterpress machines in order to use existing equipment.

**The “Recordak” Listomatic camera which was used in the Taunton experiment. Note the cards in the hopper.—Courtesy: Kodak, London.**

This was done with some difficulty and the achievement is significant. It means that a complete changeover does not require capital expenditure on very expensive rotary offset-litho machines and that any advantages in letterpress, for example—lower paper wastage on the long runs—can be exploited. There were, of course, many teething troubles inevitable in an experiment of this kind, but finally, only a year after deciding to hold a trial, the task was satisfactorily concluded. Success was due to the co-operation, loyalty and enthusiasm of many people, not only in the Post Office and the Stationery Office but also in private industry.

OVER





Part of the collating, binding and trimming machine at the Stationery Office printing works showing telephone directories being run off on a continuous belt.

This is just one stage in the exploration of new techniques for printing telephone directories. Had we been concerned only with the Taunton directory of 160 pages and a circulation of 50,000, we could have adopted a simpler approach, but the trial was designed to prove that even the London directory with 2,600 pages in four parts and a circulation of 1,200,000 could be produced in this way. We have proved, too, that this new printing method is quicker than the traditional method since it cuts out tedious processes such as proof reading and that it is just as reliable. Accuracy in directories is of paramount importance and the new method demands the utmost care in the preparation and handling of the cards, for there is little opportunity to correct mistakes once the cards have been photographed. It is not yet known how the new system will compare in cost not only with the present one but also with *Flexoprint* and *Fotolist*. Indeed, the new system is unlikely to be adopted throughout the Post Office before further trials of other methods.

However, rapid developments are taking place and the Post Office and the Stationery Office are jointly considering the application of computer techniques in this field.

In the United States, RCA 301 and IBM 1620 computers are already used for setting type for newspapers while in Britain the *Ferranti Pegasus* and other computers have been similarly used in experiments.

Some features of these processes such as automatic hyphenation are even more advanced than would be needed for directory work. On the other hand the Post Office is concerned with one of the

biggest book production jobs in Europe, not a small circulation newspaper. This means that it must look for machines to compose the text photographically from the output tape of a computer at a matching speed. At least one promising machine is at an advanced stage of development in America.

Although the use of computers for directory printing is uneconomic at present, further technical progress, particularly in the equipment associated with the computer, could change this picture. The cost might also become more competitive if directory compilation (and directory distribution instructions) were incorporated in a computer system with other similar work, for example, advice notes, telephone bills and directory enquiries.

The Taunton trial suggests that a system comprising typed cards, camera and high-speed litho or letterpress printing machines could be used for printing all our telephone directories. Soon it may be possible to undertake experiments with even more sophisticated processes. But whatever happens the success at Taunton is an important stage in the 80 year old history of telephone directory printing.



Mr. R. P. Dick is a Higher Executive Officer in the Inland Telecommunications Department which he joined in 1956 from the Savings Department. He is at present a member of a team conducting research into the Directory Information Services.



# THE YEAR GONE BY...

*“The inland telephone service is being transformed by the fast-expanding Subscriber Trunk Dialling System and further improvements are on the way... more advanced electronic telephone exchanges... a nationwide network of microwave radio-relay stations... Overseas communications systems are undergoing an equally rapid and significant expansion and improvement,” says the 1962-63 Post Office Report and Accounts*

Here are some of the highlights:

## INLAND SERVICES

### Telephones

- The number of telephones in the United Kingdom rose by the end of March, 1963, to 8.9 million.
- The number of local and trunk calls increased from 4,977 million in 1961-62 to 5,295 million. Local calls went up from 4,500 million to 4,750 million and trunk calls from 477 million to 545 million, a rise of 68 million.
- The number of calls to the Information Services was over 110 million.
- Demand for telephones also rose—to 432,000 compared with 423,000 in 1961-62—and some 418,000 new connections were provided.
- The waiting list was further reduced to 44,000.
- The conversion of manual to automatic exchanges continued at the rate of about two a week and by the end of March, 1963, there were only 628 manual exchanges left in the country.
- By the end of March, 1963, there were 474 STD exchanges, serving about 31 per cent of all subscribers. More than three million trunk calls were being dialled each week.
- Seventy-one new large exchanges were opened and 215 were extended. Some 363,000 more

OVER

## THE YEAR GONE BY (*Contd.*)

pairs of wires were provided and nearly 2,000 more trunk circuits over 25 miles long were brought into service.

- Work continued on the London Radio Tower which will, if necessary, be able to handle up to 150,000 simultaneous telephone conversations and 40 or more channels for television.
- The Highgate Wood Electronic Exchange, the first of its type in the world, was opened for experimental public service and work began on three new and more advanced systems.
- At the end of March, 1963, more than 73 per cent of subscribers were receiving quarterly bills. It is planned to mechanise all telephone billing by 1966.
- Experiments took place to find a cheaper and quicker method of printing telephone directories.

### Telegraphs

- The number of inland telegrams handled fell from 13.3 million in 1961-62 to 12.7 million, largely because of the expanding telephone system and the telex service. The number of greetings telegrams included in this total was just over three million.
- The telex service grew rapidly and the number of subscribers at the end of March, 1963, was 10,300, compared with 8,700 in the previous year.
- The number of inland telex calls also rose from 7.8 million to 10.0 million.
- The number of broadcast receiving licences issued was 15.8 million, an increase of 290,000 on the previous year.
- Nine new television detector cars were introduced during the past year.

## OVERSEAS SERVICES

### Telephones

- \* There were 8.8 million overseas telephone calls in 1962-63, an increase of one million over the previous year.
- \* Operators began dialling direct to subscribers in the United States. When the COMPAC Cable is completed at the end of 1963 operators

in Britain will be able to dial direct to subscribers in Australia and later to Canada and New Zealand.

- \* International Subscriber Dialling was introduced between London and Paris. By the Spring of 1964 ISD will be extended between London and all large cities and towns in France and to almost all exchanges in Belgium, the Netherlands, Switzerland and Western Germany. By 1966-67 subscribers in many large towns in Britain will be able to make most of their international calls by dialling the numbers themselves.

### Cables

- \* Good progress was made with the Commonwealth Cable scheme. The Australia to New Zealand section opened for service in July, 1962, and the New Zealand to Fiji section in December, 1962.
- \* Plans were completed for the laying of a third trans-Atlantic cable—TAT 3—between Wide-mouth, in Cornwall, and Tuckerton, in the United States (laying began in June, 1963. When completed, TAT 3 will provide 128 circuits.)
- \* Six new European cables are also to be laid from Britain. The first three—two to Western Germany and one to Denmark—will be ready for use in 1964. One of the existing cables to Belgium is to have its capacity increased from 220 to 440 circuits, and the microwave link between Tolsford Hill and Loos (France) will be augmented to provide another 600 circuits.

### International Telex

- \* The international telex service which is available between Britain and more than 70 other countries is growing rapidly. New services to nine other countries were opened during the past year.
- \* A new cordless telex switchboard on which calls are connected over radio and submarine cable lines in the order in which they are received was brought into service in March, 1963.
- \* By 1968 subscribers in Britain should be able to dial all their calls to Europe and to many non-European countries.

## Ship-to-Shore Radio-communication

### Services

- \* The coast stations handled 790,000 telegraph messages to ships at sea and made 15,000 broadcasts, compared with 800,000 messages and 14,000 broadcasts in the previous year. They also provided communication in more than 200 casualty cases, reported more than 400 incidents to shore authorities and dealt with about 350 medical advice cases.
- \* In addition, the coast stations handled 148,000 radio-telephone calls—about 10,000 more than in the previous year.

### Satellite Communications

- \* The Post Office played an important part in the experiments carried out during the past year with international communications by way of man-made satellites. Through the experimental ground station at Goonhilly in July, 1962, Post Office experts transmitted television pictures for broadcasting over the United States' television networks, exchanged telephone calls over the public network and transmitted colour television pictures across the Atlantic. Later, telephone, telegraph, facsimile

and data transmission signals were exchanged with the United States, first with the satellite *Telstar* and subsequently with *Relay*.

- \* "These experiments have proved," says the Report, "that satellite communications . . . may become a practical proposition within a relatively few years . . . and that the Post Office Ground station at Goonhilly . . . predominantly of British design and construction, is probably the nearest approach so far achieved to the operational station of the future."

### Finance

- \* Financially, the telecommunications services showed a bigger profit than in the previous year—£20.2 million compared with £12.6 million in 1961-62. However, this was not as much as had been hoped because of the disappointing rate of business growth in the country generally.
- \* The main contributions to the profit were: trunk calls £14.3 million, and business rentals, £5.3 million. There was a loss on local telephone calls of £4.6 million, on call offices of £3.4 million and on inland telegrams of £3.9 million. The return on capital was 7.2 per cent compared with 6.6 per cent in the previous year.



## A WARNING

**I**n a chapter on Post Office finances, the Report says that there is much greater scope in telecommunications than in the Postal Services for increasing productivity by the introduction of new inventions and improved techniques.

Of a total telecommunications expenditure of £269 million in 1962-63 interest and depreciation accounted for £98 million.

However, labour costs at £138 million were still an important element and despite technological advances, pay increases over the years had outrun productivity. The volume of business over the past ten years had increased by £99 million and this had been offset by expenditure of only £60 million. The credit margin of £39 million was available for meeting rising costs. At the same time, however, "rising rates of pay and so on have cost £64 million and rising prices £24 million, so that a substantial gap has still remained to be filled by tariff increases."

"The tariff increases which were announced in March, 1963," says the Report, "fell both on telecom-

munications, where the need for capital is greatest, and on the postal services, and were expected to produce an additional income of about £14 million (telecommunications, £8 million; postal, £6 million).

"To have saved anything like this sum by economies," the Report continues, "would have called for measures such as the drastic reduction of delivery and collection services. On the telecommunications side it would have meant cutting down heavily on staff recruitment, so delaying the installation and repair of telephones and increasing the time operators take to answer calls. It seemed clear that the cutting back of services and standards on the necessary scale would have been less acceptable to the public generally than moderate price increases."

Finally, the Report adds this warning: ". . . the need to make this choice between raising prices and lowering standards of service may be a recurrent one, unless there is a sustained national economic growth at an unprecedentedly high rate, accompanied by a much greater wage restraint."

# NEW SWITCHBOARDS SPEED

**Operator-controlled telex calls are being speeded by the introduction of new British-designed switchboards on which help is also given to callers who have difficulty in dialling their own calls**

**N**EW cordless telex switchboards have been brought into service at the International Telex Exchange at Fleet Building, London, to speed the handling of overseas calls made through an operator.

All inland telex calls and more than 90 per cent of international calls are directly dialled by subscribers. But calls over radio circuits or over cable routes on which it has not yet been possible to introduce subscriber dialling and transit and assistance calls from British subscribers must still be controlled by operators. These calls are made at the rate of about 12,000 a week.

The new switchboards—developed by the Post Office Engineering Department in co-operation with the manufacturers Ericsson Telephones Ltd—are specially designed for easy operation. Dr. W. F. Floyd, Consultant Physiologist to the Post Office, gave valuable advice on the physical characteristics of the switchboards.

There are two types of new switchboard. One handles calls over radio circuits, the other calls over cable routes and assistance calls. The facilities they provide differ in some respects but the switchboards are physically designed so that each can be converted to either use without changing the switchboard carcasses.

The teleprinters on which calls are received are the new Post Office No. 12 models, chosen because of their compact design. The positions have been given a desk-like appearance by using separate keyboards, operated electro-mechanically. The receivers are at the rear of the keyshelf in sound-proofed and illuminated perspex-fronted compartments. Messages are printed in two colours—black by the calling subscriber and red by the called subscriber. There are no dials on the positions and all selection digits are sent from the keyboard, the five units signals being converted to dial impulses automatically if required.

## **Radio Positions**

Each radio position is equipped with two connecting circuits and, because calls have to be



**A general view of the new cordless switchboards in Fleet Building. Calls are connected in the order in which they are received.**

monitored continuously, there are two teleprinter receivers. Each connecting circuit has five supervisory lamps, a cyclometer-type clock and a key. The supervisory lamps take the form of illuminated stencils—"ANS - CALL - THRU - CLEAR - RADIO"—in a black panel. The supervisorys are arranged vertically, the clock and connecting circuit key in line below them. This key associates the position equipment and common control keys with the connecting circuit. The clocks, which can record up to 999.9 minutes, are operated by a pulse (one-tenth of a minute) for every 41 characters transmitted.

Between the two rows of supervisory lamps is an additional supervisory stencilled "ACCEPT"

# OVERSEAS TELEX CALLS

By M. V. ABBOTT  
and K. C. J. HILL

which glows when the operator opens the position for an incoming call.

The forward edge of the key plate is slightly raised and spring-mounted ball bearings beneath it hold the tickets for calls in progress. On the left of the keyshelf is a row of position keys for setting up calls.

At the back of the connecting circuit key plate is a ticket slot connected by a chute to a compartment at the rear. At the back of the switchboard are two pilot lamps. One glows white when the "Call Supervisor" key is operated and the other glows red when the position equipment is not in use or is not set to accept a call and there is a free connecting circuit.

The connecting circuit consists of an incoming path selected by the connecting circuit hunter in the queuing equipment and a forward path with a 200 outlet uniselector giving access to all radio circuits and a number of cable circuits. Routes are selected by keying two digit codes.

The incoming side of the connecting circuit also has a reverse path to Fleet Automatic Exchange for calling back a subscriber when a booked call is set up. On 26 of the 36 initial radio positions this reverse path is equipped with a 25-outlet uniselector giving access to the British network and Western European countries. The remaining ten radio positions have a 200-outlet uniselector on which all radio and cable routes are connected and are used for booked transit calls.

The radio switchboards are in groups of three. Two groups—back to back and separated by a three-foot gangway so that the teleprinters can be removed for maintenance and for the removal of tickets and completed monitor copy—form a suite. At one end the two cable turning sections are joined by a horizontal writing surface to make a supervisor's desk on which are two small key panels with one key for each position. The keys are used to put unstaffed positions out of service.

## Cable Switchboards

The facilities and operating method of the cable switchboards are fundamentally the same as those of the radio switchboards but there are some differences. For instance, since continuous monitoring of cable calls is not required, positions have



A view of the positions dealing with calls routed via cable circuits. Seen in the background are the radio telex positions.

only one teleprinter and five connecting circuits. In addition, the clocks are operated by a six-second pulse and the "RADIO" supervisory lamp is replaced by a supervisory "MON" which glows when the connecting circuit is being monitored. One position key on the cable switchboard connects the incoming and forward paths of the connecting circuit with the position teleprinter for monitoring. A paper reroll attachment is used on the teleprinter since the paper tear-off procedure of the radio positions is not necessary for cable working.

The console consists of a desk with a control panel on which are mounted meters to show the  
OVER



### NEW SWITCHBOARDS (Contd.)

number of calls waiting in the cable and radio queues; switches with five settings to control the queuing equipment capacity; alarms to indicate "queue full" and "call waiting" conditions; and one key for each supervisor's desk to transfer alarms to the console when suites are unstaffed. This console is located centrally in the switchroom.

### Switchboard Operation

When a subscriber calls an operator, he selects the appropriate switchboard by dialing the required code—generally, "201" for the radio positions and "29" for the cable positions. The call is offered through the queue equipment to a position on which the operator has operated the "accept" key.

If a call cannot be accepted directly it waits in the queue until a connecting circuit is available. Operators try to connect calls on demand (formerly all radio calls had to be booked and customers called back) but the limiting factor is the availability of circuits.

**This is part of the automatic apparatus for switching telex calls. Each of two sets of common equipment (cable and radio) can handle up to 200 simultaneous calls and a queue of as many as 25 places.**

A call made through a radio position is assigned to a particular connecting circuit. The answer-back of the position (LON SWBD PXXX) is returned automatically to the caller who then signals the required number.

The call may be set up over a direct radio route (for example, to Kenya via Nairobi), or indirectly via a transit exchange (for example, to Venezuela via New York (cable + radio) or to Chile via Buenos Aires (radio + radio)).

The distant terminal operator is obtained by keying a route-selection code (route information is available on each position in a visible index file). When the called number has answered with the answer-back code or the instruction, "go ahead" is given by the terminal operator, then the London operator exchanges the answer-back signals of called and calling stations and switches the call through. The timing of the call starts automatically.

If automatic repetition of transmitted signals by the error correction apparatus is necessary because of poor radio path conditions, character counting equipment which operates the clock is stopped. Thus the clock records only the effective duration and not the total elapsed time.

The switchboard machine associated with the connecting circuit monitors continuously, thus enabling an operator to see when repetitions have been made and make allowances on the call's duration.

After a call has begun the operator disconnects the position common equipment and operates the "accept" key to allow a second call to be received on the other connecting circuit. When a call ends either party can clear the connection and timing is automatically stopped.

The timing clock is reset by operating the connecting circuit "CLEAR" key. The radio supervisory lamp indicates to the operator the way in which the call is proceeding on the radio channel. The new switchboard enables a caller, by sending four "carriage return" signals, to call-in the controlling operator to obtain assistance—a facility which no other country has yet provided.

All incoming radio circuits to London are connected direct to the automatic switching apparatus so that terminal calls to British numbers and



**This view of the rear of a radio position on the new cordless switchboard shows the access to the teleprinters.**

transit calls to European countries available via the British subscriber dialling network are obtained without the intervention of London operators. A similar facility is available on the radio routes to Japan and Lebanon where automatic national networks exist.

Because radio channels are available on an agreed time schedule and since they are subject to variable transmission conditions, a lamp indication of their availability is provided on a separate radio channel console which also enables the switchboard position controlling an outgoing call to be identified.

The console aids the supervisor and delay clerk who control calls not connected on demand. If a call cannot be connected on demand the booking is passed to the delay clerk and, as conditions permit, the ticket is taken to a suspended call position for connection.

A figure of estimated delay on each route is calculated and posted on indicators in the switchroom.

#### —THE AUTHORS—

**Mr. M. V. Abbott** is a Senior Telecommunications Superintendent in the Operations Branch of the External Telecommunications Executive. He joined the Post Office as a Youth-in-Training in London in 1934 and became an Assistant Traffic Superintendent in 1938. Apart from three-and-a-half years in the Royal Air Force on Signals duties and until he transferred to ETE in June, 1958, he worked in the London Telecommunications Region in the Centre and South West Areas and at Regional Headquarters.

**Mr. K. C. J. Hill** entered the Post Office in 1934 as a Clerical Officer in the AGD. In 1938 he became an Assistant Traffic Superintendent in the LTR where he was concerned with service and equipment in the West Area and with exchange traffic testing at Regional Headquarters. He joined ETE in 1953 on promotion to Senior Telecommunications Superintendent and has since been responsible for International Telex planning.

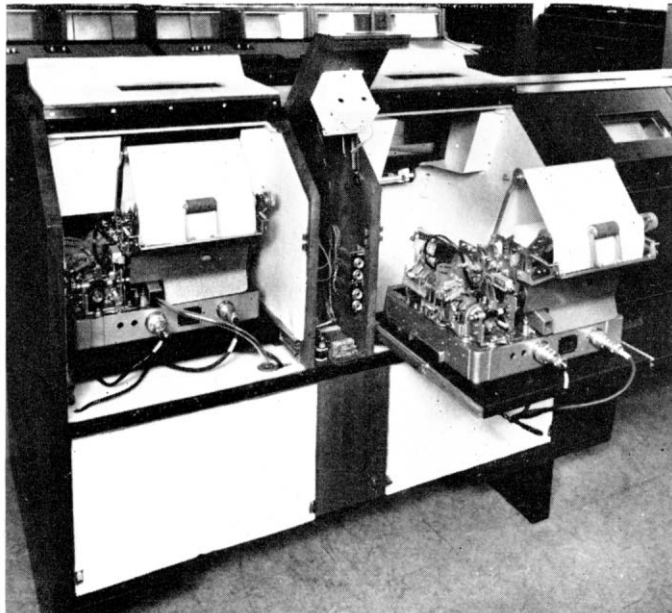

When an operator leaves a position the supervisor operates a key on the control panel at the end of a suite to close the position. If a call has been left connected an alarm is extended to the supervisor when it clears. Similarly, suite position alarms are extended to the central control desk.

At the end of each call, the control ticket—and, for a call originated in Britain, an account ticket—is completed with the report of the chargeable duration and then put down the ticket chute. The tickets are processed for the preparation of the monthly international accounts and then sent to Telephone Managers for billing subscribers.

The local copy of the messages is filed in case of queries.

Calls are connected over cable circuits to European countries to which subscriber dialling is not yet available and to countries reached over the long-distance submarine cable systems to North America and, later this year, to Australasia. Customers generally dial "29" for these calls which are routed through queuing equipment to the cable switchboard and, if possible, connected on demand. On certain routes where the number of circuits is insufficient at times, however, calls have to be handled on a "delay" basis.

The timing equipment is started automatically

OVER



**A radio control position at the old International Telex Exchange in the CTO.**

(2003) are handled on 19 standard teleprinter circuits. Later, special positions will be developed for these services.

The "Teleprinter on Radio" multiplex equipment which gives channelling and error correction facilities on radio circuits is at Electra House. Additional equipments are being installed in Fleet Building.

To check incoming service and observe conditions on any route, a set of teleprinters monitors the service under the vigilance of a patrolling operator. An observation desk is also equipped to take observations on the customer-dialled outgoing services to Europe. Plans have been made to provide an observation desk to be associated with any incoming or outgoing circuit from the inland network or on the international systems.

### The Future

The International Telex Service is growing rapidly. More countries are continually being added to the network, more intercontinental cables are being laid to provide cheap and reliable circuits and fully automatic service is being extended as quickly as possible. All these developments affect the cordless switchboard.

Apart from the normal growth of traffic the opening of the Commonwealth and American cables in the Pacific and South East Asia will result in the conversion of the New Zealand, Fiji, Australia, Singapore and Hong Kong and Japanese telex services to cable working. This traffic will then be handled on cable switchboards, but the additional load will be offset by the progressive introduction of fully automatic service.

Although the new cordless switchboards are designed for conventional cable and error-corrected radio circuits, any look into the future must take account of the possibility of very stable world-wide circuits provided by satellites. It is hoped that these circuits will operate as cable circuits and, where they replace error-corrected radio circuits, they should speed the introduction of fully automatic service. Successful test calls have already been made by way of the satellite *Telstar 1*.

### NEW SWITCHBOARDS (Concluded)

and the call is switched through after the exchange of "Answer backs" of called and calling parties. Assistance calls are also fed into the queue. Since this is the only manually-operated Telex Exchange in Britain assistance service is available for both inland and overseas customer-dialled calls. Operators also deal with calls by overseas terminal operators wanting London via code "9" when they have had difficulty obtaining a British or European directly-called number or when they require a transit call.

The radio and cable positions also receive bookings from operators in other countries for transit calls over the direct services (for example, Japan via London to South Africa, or Spain via London to Canada). These calls are handled similarly to those originated in this country.

### Enquiry Calls

Enquiry calls about the International service (2006) and Inland and Overseas directory numbers

#### AVERAGE TRAFFIC PER WEEK (MARCH 1963)

Customer dialled calls to Europe ... ..	119,000
Assistance calls to Europe ... ..	600
Other calls connected by operators to Europe	5,500
Calls connected by operators to USA (by cable) ... ..	2,000
Calls connected by operators to Canada (by cable) ... ..	650
Calls connected by operators to Extra-European countries (by radio) ... ..	2,900

#### AVERAGE CHARGEABLE TIME PER CALL

Customer dialled to Europe ... ..	2.4 mins
Operator-connected to Europe ... ..	4.3 mins
Operator-connected to Extra-European countries ... ..	7.0 mins



The Altrincham automatic telephone exchange—a fine example of the new approach. It was built at about half the cost and in much less time than any other similar exchange.

# MORE FOR THE MONEY

By A. H. RIDGE

The Post Office is spending more than £10 million a year on new buildings. Since the needs are likely to increase every effort must be made to provide more and better buildings more cheaply than before. How is this to be achieved? The answer is through the work of the Joint Post Office/Ministry of Public Building and Works Research and Development Group, the story of whose aims and activities is told in this article by Mr. A. H. Ridge, Director of the Post Office's Clerical Mechanisation and Buildings Department



**A**S the *Journal* went to press work began on two new automatic exchange buildings which will be the same size and designed to a standard plan.

One of them—at Wantage, in Berkshire—will be built by orthodox methods. The other—at Heath End, in Surrey—will be constructed from factory-made components: the first time the Post Office has used prefabricated parts on this sort of scale. Each new exchange will cost about £18,000 to build—some £4—£5,000 less than the cost of any previous similar building.

These two building schemes are the latest—and a most impressive—example of what is being

achieved by the Joint Post Office/Ministry of Public Building and Works Research and Development Group, a specialist organisation set up nearly six years ago to study and develop methods of planning and erecting Post Office buildings at the lowest possible cost and more quickly than ever before.

The Research and Development Group was established in the autumn of 1957 when the two departments agreed that the problem should be tackled by one organisation, composed of Post Office technical experts on the one hand and Public Building and Works professionals on the other. In this way clients with specialised needs

OVER



**The apparatus room at Altrincham automatic exchange which enjoys natural lighting.**

### MORE FOR THE MONEY (*Contd.*)

would be brought into direct contact with the architects who have to meet those requirements. It was laid down that the Group should “develop such methods as will enable Post Office buildings which are operationally effective, to be planned and built at minimum cost with maximum speed . . . and study all aspects of the work . . .” In addition, the Group would examine the economics of building (including cost planning) and the possibilities of prefabrication, keep in touch with other development and regular functional branches and field and executive organisations in both departments, and study practices followed by other concerns in Britain and foreign postal administrations.

To demonstrate this new approach in a practical way the Group first tackled the planning and building of three entirely different, but typical Post Office buildings—an automatic telephone exchange at Altrincham, a Head Post Office at Hitchin and a telephone engineering centre at Plymouth.

In each case the Group began by critically examining the needs the building was intended to serve and reappraising the basic operational space requirements. Then it produced the plan, which was governed by eight main principles. The first of these principles was that initial building should be restricted to the reasonably certain needs for an initial period of 10–15 years, requirements beyond

that time being provided by flexibility in planning and construction and not by unnecessary building at the outset. Second, circulation space should be reduced to the minimum and, third, all parts of the building should be suitable for their purpose, rooms being of the right shape as well as the right size and considered in relation to furniture and equipment which, in turn, must be suitable for their function. Fourth, shape and design should be planned so that the ratio of external walling to floor space is kept as low as practicable and, fifth, the forms of construction should be economical and suitable for the particular purpose. The other three principles were that materials should be suitable for their purpose and not expensive to maintain; that colour treatment and finishing materials should be attractive but not expensive; and that a close watch should be kept on costs through every stage of planning, design and construction.

The first fruits of this enterprising and more efficient approach are already in evidence. The new automatic exchange at Altrincham, which came into service last October, was built in eight months at a cost of £23,000—in much less time and at about half the cost of any other similar exchange. One important feature is that the building can be extended simply by removing a lightly-constructed end wall. Thanks to the Group's exploitation of new space saving equipment practices, the saving in floor space compared with previous similar exchanges is as high as 40 per cent. Ancillary rooms are sited on two sides of the apparatus room in which even natural lighting is achieved by the use of a Group-designed inverted double-pitch roof and continuous high-level glazing. A careful reappraisal of these novel features will be made in the near future.

The new Head Post Office at Hitchin, which also exemplifies the way in which careful operational planning can reduce space requirements, was built in 12 months and the cost—about £64,000—was about two-thirds of the amount estimated before the Group applied its new approach to planning and design.

The ground floor of this office is designed as a shell with light internal partitions which can be moved to expand any section. The public office

**The new Head Post Office at Hitchin is an example of how planning can save space and money.**

for example, can be extended into the sorting office to provide 25 per cent more room for a loss of only four per cent of space in the sorting office.

The Plymouth Telephone Engineering Centre, work on which began in May 1962 and which is expected to be complete by November this year, presented some problems. Many different layouts had to be considered to allow for the contours on the site and the requirements of the local planning authority. Finally, it was decided to group the building compactly in three main blocks; a service area workshop; a section stock and works order store with adjacent welfare accommodation; and a two-storey administrative and workshop building. The cable compound and pole stack area are sited well away from the main frontage and a vehicle park is planned so that, if necessary, the garage roof can be extended over it.

All the features of this centre were designed after close study by the Group of the operational requirements, the need for good working conditions and for economy. Economies have been achieved, for example by combining some of the accommodation for work and recreation, by providing a two-span construction with fixed lifting beams instead of the more expensive travelling beams construction, and a favourable layout made it possible to dispense with the usual partitions round the washing and lubricating bays in the garages.

In these highly successful practical experiments the Group has had the full support of the staff associations at both national and local level and this has contributed to the effectiveness of its work. In the Plymouth operation, for example, the staff side agreed to an experimental departure from normal agreed standards in the welfare accommodation which was an essential part of the whole scheme.

Since its inception, the Research and Development Group has produced two very powerful instruments of cost control. The first lays down a limit of cost per square foot (according to the type of building) within which the architect is expected to design. If the estimated cost exceeds the limit the architect has to state his reasons to the Post Office Regional Director before authority can be given to continue. In setting the limits, the Group



had to carry out a great deal of detailed pioneering work, examining a number of building schemes in great detail and deciding the best factor of cost.

Cost is also controlled by imposing a minimum planning ratio—that is the total area of all working and welfare rooms expressed as a percentage of the complete area—on all buildings. These ratios vary from 85–95 per cent but better results have already been achieved. At the Altrincham automatic exchange, for instance, the ratio was 98.8 per cent.

The Group is also studying the problem of how to make the best use of standardisation and pre-fabrication which save time and money in planning, designing and building. Recently, thanks largely to the valuable experience gained on the Altrincham project, it produced standardised designs for the H-type automatic telephone exchange and is now developing new plans for the larger standard K-type exchange. The Group is also studying the possibilities of standardising postal buildings: for example, town delivery offices.

Since the Research and Development Group is essentially concerned with applied research it must be constantly informed about the way in which “bread-and-butter” buildings are being planned and erected and of any new service problems affecting buildings. Furthermore, it is absolutely essential for the results of the Group’s work to be communicated to the workers—in the field—otherwise its labour will be lost. The Group achieves both these purposes by regularly inspecting selected building schemes early in the planning stage, thus coming into close liaison on live schemes with the architects, Post Office operational planning officers and local managers. On these occasions the Group may propose changes which will lead to economy, but the main object is personal

OVER

A general view of the test room at the new Altrincham Exchange. Note the roof light apertures in the ceiling.



**MORE FOR THE MONEY (Contd.)**

contact, the two-way exchange of information between the Group and field workers. The Group collaborates closely with Headquarters and staff in the field in other ways, too, (for instance, by the issue of technical notes) and maintains contact with other building research organisations in this country and with the postal and telecommunications departments of foreign administrations.

The Group's work has had a threefold result. First, time and money has been saved. Second, methods and standards have changed for the better not only in construction work but also in planning. Already the Group's proposals have led to improvements in such things as the design of windows in apparatus rooms and switchrooms and the introduction of standard column spacing for telephone stations and repeater stations. Trials are currently being held to find out whether heating and ventilation systems for telephone exchanges can be efficiently combined. Third, and most important, the close liaison with the field is bringing

all those who are involved in building projects to approach them in the new way that the Group has sign-posted.

Although the Group's aims will remain unchanged, the future will inevitably see some changes in emphasis and direction. For instance, work will be intensified on standardisation, rationalisation and the use of mass-produced, prefabricated building techniques and the Group will keep even closer touch with all developments in building research. If mass-production can be adequately applied to Post Office buildings the economic dividend to be won could become substantial. The Group will also intensify its contact and inspection system since it can only be successful if it has the co-operation and understanding of all who plan, design, construct and work in Post Office buildings.

**— THE AUTHOR —**

Mr. A. H. Ridge entered the Administrative and Public Relations Departments in 1937 as an Assistant Principal. Apart from a spell of three years as Principal Private Secretary to the Postmaster General, he has served mainly in Headquarters Departments on work concerned with posts (over-seas mails) and personnel. He has also served in the North-Eastern and London Postal Regions and, during World War Two, in the Home Office Civil Defence Organisation. He was appointed Director of Clerical Mechanisation and Buildings in 1960.

**\*\*\*\*\* 9 MILLION TELEPHONES \*\*\*\*\***

\*  
\* On 10 July Mr. Roy  
\* Mowby, the APMG,  
\* presented the nine  
\* millionth telephone  
\* in Great Britain to  
\* Mr. R. E. Crouch, a  
\* production foreman  
\* for a Hortlepoons  
\* firm, who lives at  
\* Peterloo. In this  
\* picture Mr. Mowby  
\* and Mr. Crouch  
\* watch Mrs. Crouch  
\* making the first call  
\* on the instrument.  
\* Britain now has more  
\* telephones than any  
\* other country except  
\* the United States.  
\* Courtesy: Northern  
\* Daily Mail.  
\*  
\*  
\*  
\*





**A dan buoy, with a radar reflecting top to mark the channel to be swept, is launched from the Royal Navy minesweeper *Wolverton*. From these buoys all navigation was calculated.**

## FOR CABLES

**THANKS to the navies of three nations the way is now clear for Post Office cable ships to lay three more submarine cables across the North Sea.**

The three navies—the British, Danish and West German—were called in because World War Two minefields guarding the approaches to Esbjerg, Denmark (the shore-end point for the Anglo-Danish cable) and Borkum, West Germany (shore-end point for two new Anglo-German cables) had not been cleared. Their job was to sweep two channels—one 40 miles long and a mile wide off Esbjerg, the other 45 miles long and two miles wide off Borkum—and make them safe for the cable ships.

The task was completed ten days ahead of schedule in mid-July and the Royal Navy, using

a task force of 23 ships, directed both main sweeps. The West German and Danish navies carried out preliminary sweeps. During the two sweeps the Royal Navy Task Force steamed more than 24,000 miles.

The shore-ends in Britain of the three new cables have already been laid at Winterton, in Norfolk. HMTS *Ariel* will extend the shore-ends in October this year and in November, HMTS *Monarch* will lay the first cable from Borkum. Then, in June, 1964, *Alert* will lay the Anglo-Danish cable to Esbjerg and in August, 1964, the second cable to Borkum.

Three more North Sea cables—one to Norway and two to Holland—will be completed by the end of 1966 (see *Expanding the North Sea Cable Links* in the Summer, 1963 issue).



The first time an injection facility was provided, the radio channel equipment was perched in the cabin on top of this 100 ft high self-supporting tower at Charwelton.

ONE OF THE POST OFFICE'S IMPORTANT TASKS IS CONNECTING THE BBC'S AND COMMERCIAL TELEVISION COMPANIES' OUTSIDE BROADCAST PROGRAMMES TO THE NATIONWIDE NETWORK OF TELEVISION CIRCUITS. THIS IS THE STORY OF SOME OF THE LITTLE-KNOWN ACHIEVEMENTS OF THE TELEPHONE AREA MAINTENANCE STAFFS IN INJECTING THESE PROGRAMMES INTO THE MICROWAVE RADIO SYSTEM

By A. G. HICKSON

## ***THEY HELP TO PUT THE***

**W**ITH the advent of *Telstar* and *Relay*, the first communications satellites, many more people have become aware of the important part played by the Post Office in providing the links for the television services in this country.

Much has been written, too, of the work of the specialist Regional and Headquarters outside broadcast groups which provide the many temporary circuits needed to make possible the networking of outside broadcasting events for both the BBC and the ITA and inject outside broadcasts into the main line coaxial cable systems.

Little, however, has been told of the work carried out by Telephone area staff—the men who

maintain the main line television carrying systems—who also, from time to time, inject outside broadcasts into the microwave radio systems.

The role they play in a field normally exclusive to the specialist is typified in this story of how, in the past three years, the Coventry Telephone Area maintenance staff have injected more than a hundred outside broadcasts into the London to Birmingham microwave radio link—the route on which the pioneer multi-hop television radio link was first brought into service in December, 1949—at the Charwelton Radio Station in Northamptonshire

Charwelton has been chosen as the example because its geographic position ensures that it plays an important part in providing injection facilities,



This is the six-channel injection facility and monitor equipment now in use at Charwelton and on which many programmes have been sent to London and Birmingham switching centres.

although injections are frequently made at other stations with the help of portable equipment, and because it is typical of many stations which have subsequently been brought into use on other systems.

The equipment at Charwelton, which normally functions as an intermediate microwave radio repeater, ranges from a diesel-driven standby power plant to VF supervisory systems, microwave radio receivers and transmitters and various items of test equipment for operating and maintaining the station. The main signal is not brought down to baseband frequency, that is, the frequency necessary to produce a picture when fed direct into a television monitor, the only equipment in this range being used for monitoring.

This story really begins one day in 1956 when the ITA asked if a television programme of motor racing from Silverstone race track nearby could be injected into the main system at Charwelton. The programme was to be brought to the station on a mobile microwave link supplied by the commercial television company. At this time the only system working through Charwelton was the 900 Mc/s Radio System 9/1 between London and Birmingham. The intermediate frequency to which the main signal was reduced for amplification was 34 Mc/s, this then being restored to 900 Mc/s before transmission to Birmingham.

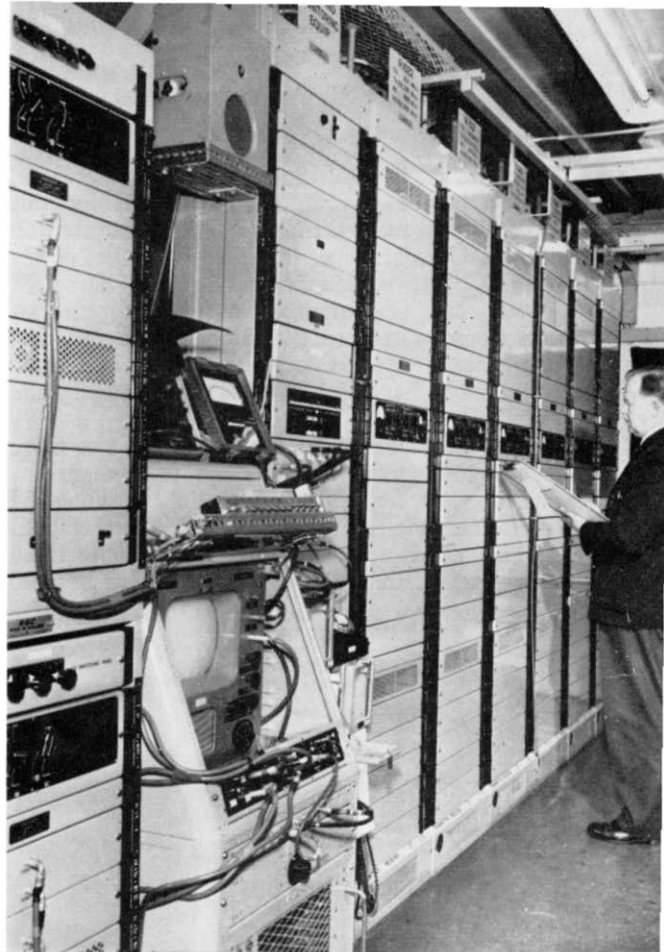

## **PICTURES ON YOUR SCREEN**

The Post Office decided to provide a temporary injection facility and arrangements were made to borrow suitable frequency equipment capable of handling the signal from the television company and with an output suitable for injection into the radio channel.

The radio channel equipment was housed in a cabin on top of a 100-ft high self-supporting lattice tower. For this first occasion it was decided that the Midland Region Outside Broadcast Group should be responsible for operating the baseband equipment and providing and operating the test equipment.

The injection facility was installed and its performance checked by staff who had to sit on the floor of the cabin in the small space still free of

equipment. Later, programme injection was successfully completed and the baseband equipment returned to Birmingham terminal station.

In 1959 a similar request was received but by this time the 900 Mc/s radio system had been supplemented by two 2000 Mc/s channels between London and Birmingham, the equipment being housed in a ground floor building. Because of ease of access and availability of baseband equipment it was decided to inject this programme into one of these new channels instead of the 900 Mc/s one. It was also decided that since the local maintenance staff were more conversant with the techniques used on this type of communication system, they should be responsible for the injection facility, thus

OVER

## THEY HELP (Contd.)

releasing the specialist group for work elsewhere.

The baseband equipment borrowed for this occasion was more complicated than that used on the first programme injection and the power supplies were derived from a number of borrowed power units. The equipment was of the type normally mounted in a rack but since no rack space was available the panels were arranged on a table adjacent to the channel which was to carry the programme.

The test and monitor equipment was also more lavish and although it was not tailor-made for injections it enabled a vision link of enhanced performance to be provided to the terminal station.

The technique of injecting a signal into these 2000 Mc/s channels was also complicated because

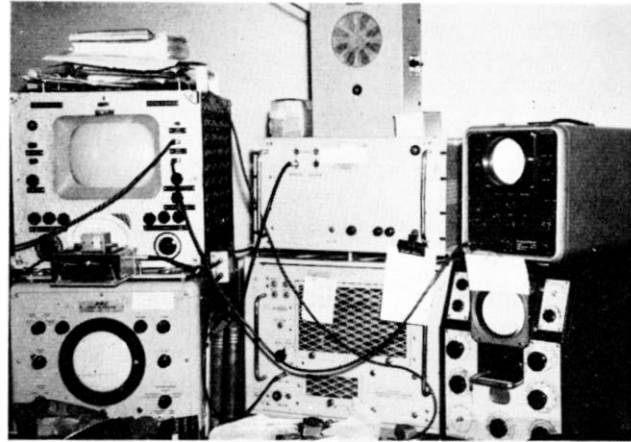

Above: The test and monitor equipment used for the injection of an outside broadcast programme in 1959. Left: Diagram of the injection facility on 900 Mc/s radio link.

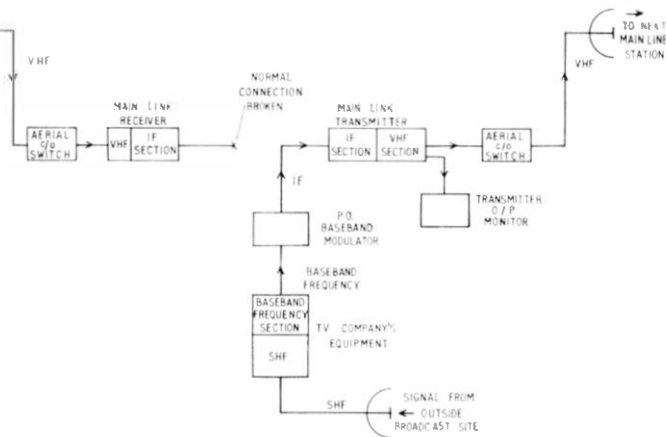

at each of the intermediate stations between London and Birmingham the frequency spectrum was reversed, thus reversing the polarity of a television type signal. (This effect can be likened to a monochrome photograph where the positive picture is the normal print and the reverse polarity is the negative from which the print is obtained). Since Charwelton is the last station before Birmingham terminal station this meant that a normal positive picture injected at this point would appear as a negative at the normal system output. To overcome this problem a reversal of polarity had to be introduced so that the receive terminal station could still pass on to the programme company a positive television picture when injection was taking place.

An attempt to do this was made by using an extra equipment panel normally employed for other purposes, but because of the side effects the scheme was found to be unsuitable. Finally, however, it was discovered possible to intercept the signal in the receive station terminal equipment which was the reverse polarity to the main output, the point of interception being restored when the channel was again needed for traffic between London and Birmingham.

Although this was only a temporary arrangement it was used on 30 other occasions in the following 12 months, during which time the general arrangement of equipment, monitoring facilities and power supplies was gradually improved to provide better performance and improve ease of operation. The baseband frequency techniques which, until the advent of this facility had not been part of station staff's commitments, now became normal practice.

Later, during an outside broadcast injection when programme bookings on the radio channels were heavy, it became necessary to allow a programme to be fed direct from London to Birmingham on the channel being used at the time for the outside broadcast injection at Charwelton. Since the London programme was to alternate with the outside broadcast a degree of flexibility had to be provided at the injection point to allow the switching from one programme source to the other at a moment's notice. Instead of going through

This schematic diagram shows the way in which the injection equipment was coupled to the radio channel.

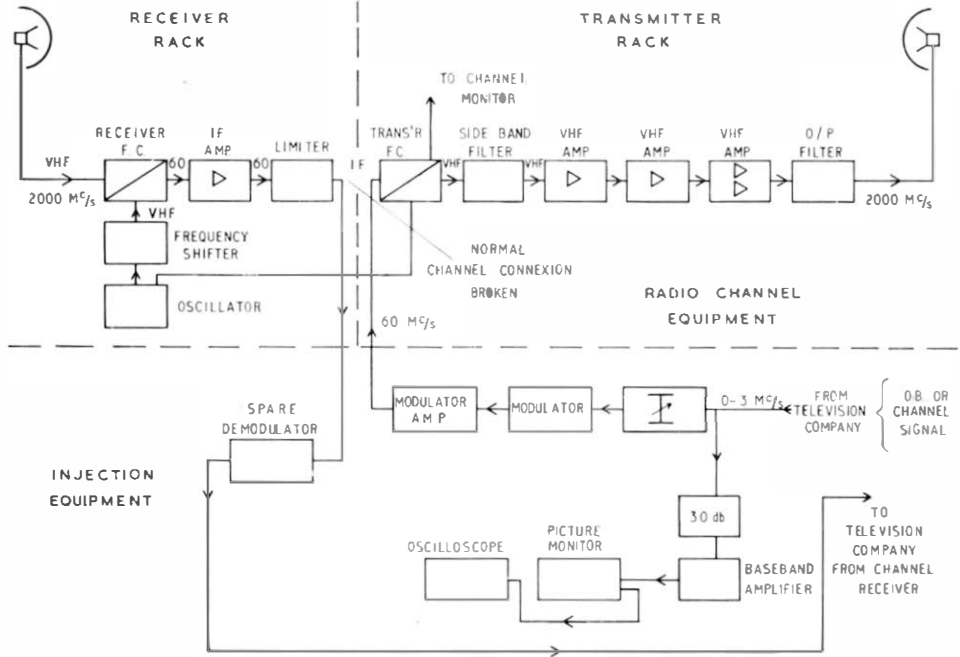

Below: The transmitter of the 900 Mc/s system into which the original programme injection was made.

Charwelton in the normal way, the signal from London was intercepted by additional equipment, thus bringing the programme under local switching control to allow either the London or the outside broadcast programme to be switched through to Birmingham when instructed by the programme producer at the television programme switching centre. This became a normal part of the equipment provided by the Post Office staff.

The number of outside broadcasts dealt with was maintained until, in 1960 with the installation of six new 2000 Mc/s channels—three London to Birmingham and three in the reverse direction—the need arose to re-appraise the facility. Two racks of injection equipment were ordered from the manufacturers of the radio equipment used on the London-Birmingham link, each embodying the main facilities required. Signal polarity inversion and other facilities were incorporated on these racks together with the necessary power supplies. With this new equipment it was now possible to present a signal which conformed to the standards normally expected on a main-line link.

This final arrangement on injection facilities and monitor equipment which is now in use at Charwelton consists of two mobile trolleys, one with the main and standby injection racks mounted on it, the other carrying the monitor and test equipment. These two trolleys stand near the station miscellaneous rack at the end of the suite of six radio channels. The miscellaneous rack carries the equipment needed to reduce the channel monitor

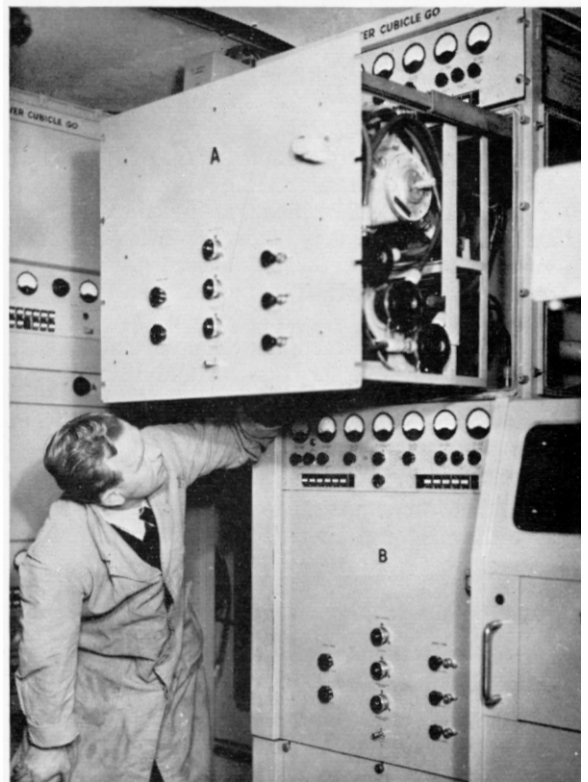

OVER

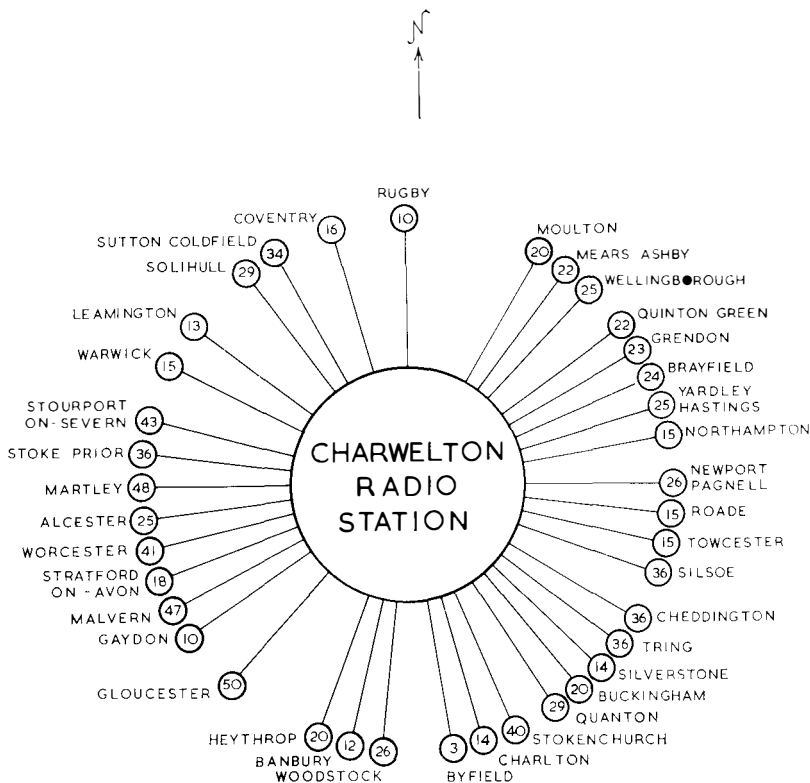

**This diagram shows the many places from which outside broadcast programmes have been injected at Charwelton (the figures in the circles are the miles each place is away from Charwelton), some for immediate transmission, others for recording. More than a hundred programmes have been injected since 1959.**

### THEY HELP *(Concluded)*

feeds to the correct condition for display as a picture or wave form screen.

The control panel which provides the switching facilities is immediately below the picture monitor on the test trolley and the oscilloscope, with other items of test equipment, is mounted on top of the trolley.

Using this equipment, many programmes have been sent to both the London and Birmingham network switching centres, often at short notice. Of more than 100 injected into the London-Birmingham microwave link at Charwelton, from 1959 until December, 1962, some were for immediate transmission to the public, others for recording for use later. They have ranged from

motor racing to variety shows, from horse racing to wrestling, and from farming programmes to church services. Their geographic location has extended from Gloucester to Northampton, Rugby to Stokenchurch, the signal in each case being brought to Charwelton over a mobile microwave link installed by the programme company. This wide coverage is due to the prominent position—750 ft above sea level—which Charwelton Radio Station occupies. On all but one of the 108 programmes injected, local maintenance staff have been responsible for lining-up, maintenance and operation of the facility, illustrating yet one more service which has now become part of the ordinary day-to-day duties carried out by Telephone Area maintenance staff.

### —THE AUTHOR—

Mr. A. G. Hickson joined the Engineering Department in 1937 as a Youth in Training on the external staff. In World War Two he served with the Royal Corps of Signals in Europe and West Africa. Returning to external work on demobilisation he became a Technical Officer in 1947 concerned first with maintenance of telegraph and transmission equipment and later with Clerk of Works and maintenance duties at an

intermediate station of the London-Birmingham Microwave Link.

Since 1949 Mr. Hickson has been concerned with maintenance duties on the London-Birmingham coaxial systems, microwave radio systems and auxiliary services, including outside broadcast (television) injection facilities on microwave radio systems on the London-Birmingham Radio Link.

*Equipment which safeguards local cables against damage and makes good losses by providing a continuous flow of air is being installed at many large exchanges. The system may be further extended in the near future*

# CURING THE LEAKS IN LOCAL CABLES

By J. F. KEEP

**F**ROM time to time underground telephone cables develop cracks or holes through which water penetrates and causes breakdowns and faults.

To overcome this problem in trunk and junction cables most of them are now pressurised by air so that the pressure inside the cable sheath is greater than the outside atmosphere.

Now, the system is being taken a stage further and equipment is being installed in some 600 or so of our larger exchanges of 2,000 lines and over, to provide a continuous flow of air sufficient in volume and pressure to make good losses and to safeguard local cables against damage. Smaller exchanges in areas subject to serious flooding or to isolation may also be pressurised in the near future.

Although the method of determining the point of leakage from cables remains the same as for trunk and junction cables, the system of pressurisation for local cables is different.

Unlike a trunk and junction cable, which is laid from point to point with few interruptions, a local cable divides and sub-divides immediately after leaving the exchange as pairs are taken from it to feed cabinets, pillars or other distribution points. This gives rise to a complicated network of cables of different sizes, especially in large towns, and means that the exchange is the only point at which air can conveniently be applied to all branches of the cables. Consequently, the effective range of the pressurisation equipment is determined by the size and type and, therefore, the resistance of the cables to the passage of air through them, the degree of air-tightness along the route and the maximum amount of pressure which can safely be applied to the cable sheaths. Unfortunately, too, cabinets,

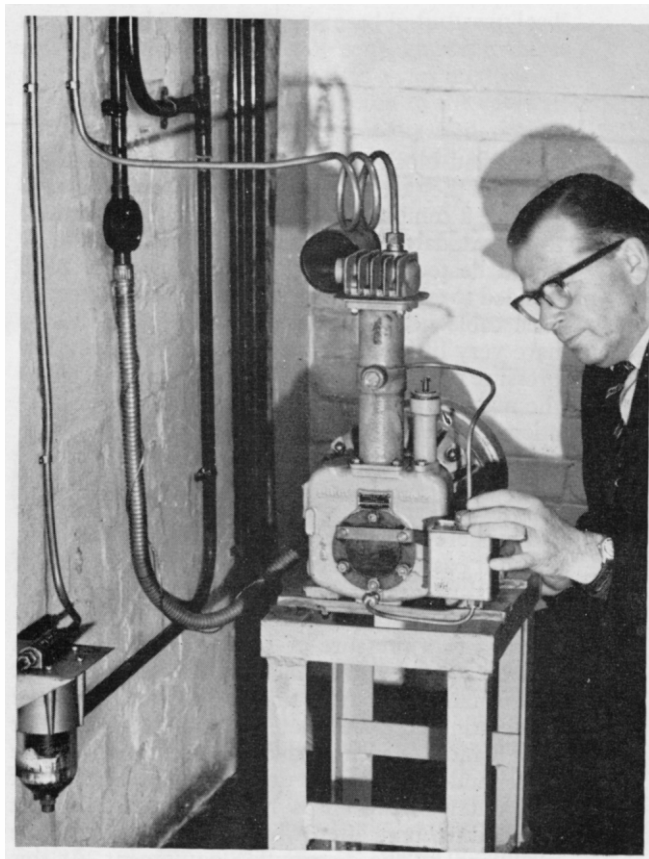

The author demonstrates the machine which compresses air to 50 lb. a square inch and delivers it uncontaminated by oil.

OVER

**This diagram shows the layout of the component parts of the air supply and distribution equipment.**

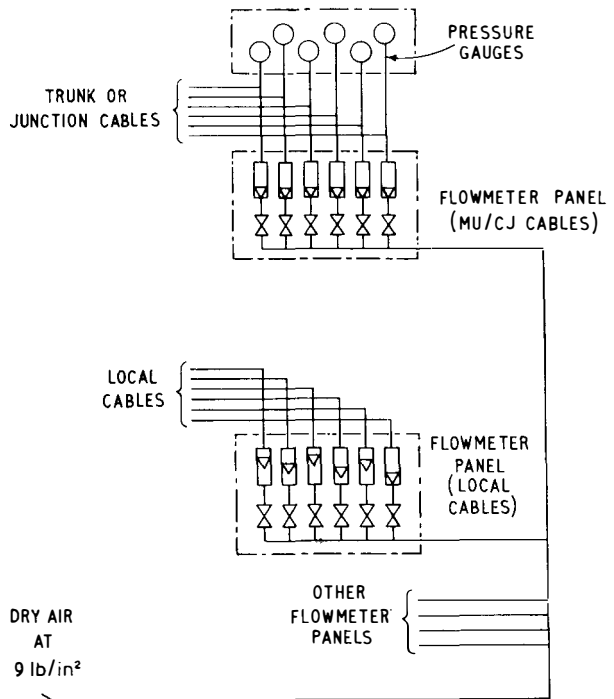
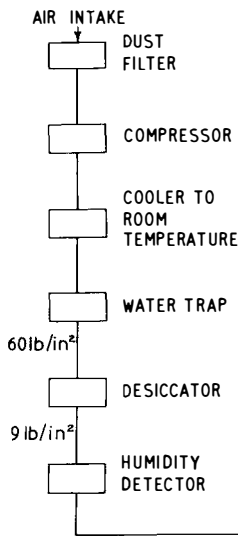

pillars and block terminals are not pressure-tight although they are filled with wax to keep out damp.

Since a completely leak-free system pressurised to the standard of the trunk and junction network would be too expensive to maintain it has been decided to adopt the continuous air-flow system in local cable networks. Because lead cable sheaths have very little tensile strength the relatively low pressure of 9 lb a square inch has been selected as the maximum working pressure for all pressurisation schemes.

How does the air supply and distribution equipment in an exchange work? First, air (usually heavily laden with water) is taken from the atmosphere and filtered to remove dust particles. Then it passes into a compressor (a special type of reciprocating machine without piston rings which delivers air uncontaminated by oil) and is compressed to a pressure of 50 lb a square inch. In this process the air becomes heated and because hot air would interfere with the efficiency of the desiccating unit, it is then passed through a cooler unit which condenses a large proportion of the water and automatically drains it away. The rest of the water in the air is finally extracted by the desiccating unit after which the air is fit to be delivered by the distribution equipment. At this stage the water content of the air has been reduced from about 10,000 parts in a million when it enters the compressor, to 20 parts in a million, or virtually bone-dry air.

The care taken to deliver bone-dry air to the cable network ensures that the insulation standards of the cables are maintained. To safeguard against the accidental delivery of wet air caused by a fault in the drying equipment, a moisture detecting unit is placed in the air line immediately after the desiccator. This instrument stops the compressor and raises an alarm if there is a dangerous rise in water content.

The air is finally passed to the cable network through a series of manifolds and flow-meters—small glass tubes in which extremely light floats remain suspended. Each tube is calibrated in feet per hour to show the rate at which air is being delivered, and one is provided for each cable. A shut-off valve in each flow-meter may be used to isolate the cable from the main air supply.

As well as supplying air to the local cables in an exchange area, the equipment also provides air for all the trunk and junction cables terminated in the exchange.

The desiccating, distribution and alarm equipment, which can serve up to 60 cables, is mounted on a standard rack in the exchange apparatus room, the air lines connecting it to the cables being nylon tubes a quarter of an inch in diameter. The monitoring and test equipment for use with trunk and junction cables is mounted alongside. In small exchanges where no more than 18 cables are to be pressurised a small diaphragm compressor is incorporated in the desiccating unit. The compressor

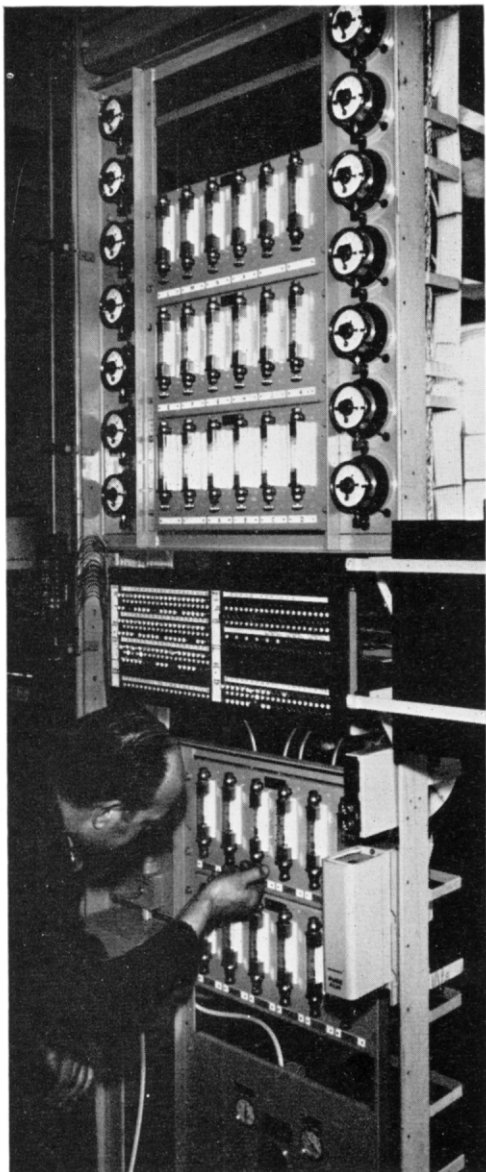

**This rack contains all the equipment necessary for the final drying and metering of the air delivered to each cable and the test equipment for monitoring the pressures at the far end of the cable.**

is normally installed in the power room or in some other place where some noise may be tolerated.

To avoid unnecessary waste of air and to extend the effective range of the compressing unit over as great an area as possible, all cable terminations are sealed in the exchange cable chamber and at all cabinets and pillars. The seals are made by impregnating a section of the cable with a special mixture of natural pine resin and a mineral wax. Construction varies according to size and in exchange cable chambers, where the larger cables are sealed, a small sleeve is plumbed over a section of the cable from which the sheath is first removed. The sleeve is then filled with hot wax under pressure. Smaller cables are sealed by injecting wax directly into the core.

Synthetic resins, which are used to seal plastic insulated cables, may also be used in future in lead and paper core cables. At present, however, these resins are much more costly than a wax mixture.

Pressure test points are soldered to the cable at various points along the route. Only a minimum number are fitted at first, others being added as required when leaks are found. The test points consist of a specially designed valve with a small schrader-type valve core about half the size of those used in motor car tyres.

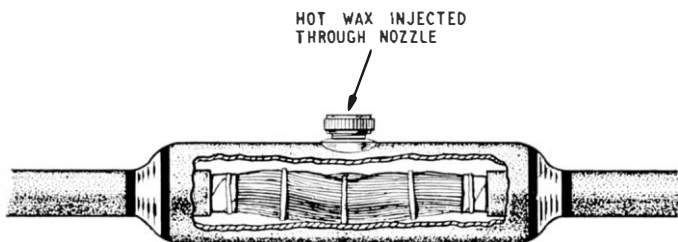

**The smaller cables are sealed by injecting the hot wax directly into the core.**

Small pressure gauges, with an adjustable contact and similar to those used on equipment in the exchange, are fitted in some cabinets sited towards the end of the route, and are connected to the cable by quarter-inch diameter polythene tubes. These gauges, which are complementary to the flow-meters in the exchange, are necessary because of the effect of the high pneumatic resistance of the smaller cables. This resistance to the flow of air is analogous to the resistance in an electrical circuit and varies approximately in

OVER

## CURING THE LEAKS (Contd.)

proportion to the length of the cable and inversely with its cross-sectional area. This means that the farther the leak is from the exchange, the smaller

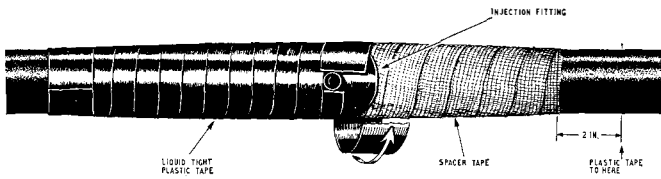

**Synthetic resins—more expensive than wax—are used to seal plastic insulated cables.**

is the amount of air flowing along the cable towards it. It is thus possible for a large leak to exhaust the air from a remote section of the cable at a faster rate than it can be replenished. If this happened water could penetrate the core should the duct track become flooded.

Once an alarm has been received in an exchange, either by the operation of a remote pressure gauge or by direct observation of an increase on a flowmeter, the pressure along the cable is checked. For this purpose a simple mercury manometer is used and the readings are plotted on graph paper, the point of leakage being indicated by a curve.

To keep maintenance costs down to the minimum only significant leaks, which are fairly easy to discover, are sought and the smallest leaks are

A telephone cable consists of a number of electrical conductors insulated from one another and enclosed in a lead or plastic sheath. A large cable used in a local network contains as many as 1,800 pairs of wires. These cables are usually in ducts under the surface of the street and, although it is reasonable to expect them to remain undisturbed, they are, in fact, subject to many hazards which may cause cracks or holes to develop in the sheath. It is through these defects that water can enter the core (for example, after a heavy rainstorm) and reduce the insulation resistance between the conductors to such a degree that the cable is put out of action and an expensive repair becomes necessary. In these circumstances faults can only be detected after damage has occurred.

Pressurising cables with air has three big advantages. First, since water is prevented from entering it the cable can be used and no traffic is lost. Second, by means of contractors operated by gas pressure alarms can be given at a local exchange, and a rough localisation provided. Third, a fault occurring at an inconvenient time, for instance at a week-end, can be left and repaired later.

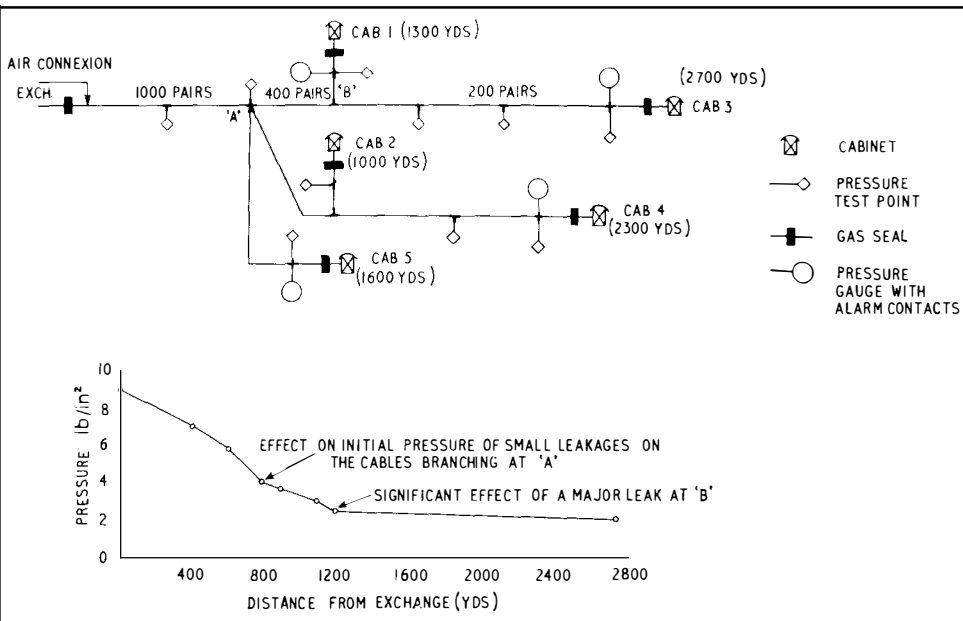

**A diagram of a typical layout of test equipment on a pressurised cable, showing the more important pieces of equipment associated with each local cable.**



ignored. As a general rule no action need be taken to locate leaks if the pressure at the end of a cable can be maintained at 3 lb. a square inch. This amount of pressure provides an adequate degree of protection and is sufficient to prevent a six-foot head of water entering a small crack in a cable sheath. Water may enter if the hole is a very large one but penetration is limited to the area around the hole and only the immediately adjacent pairs become damp and fail to provide service.

The effect of pressurisation is, of course, most effective where an area has been completely treated. Partial pressurisation is not so effective because faults will continue to occur in cables beyond the pressurised section.

When an area is pressurised for the first time many air leaks, averaging two in every mile, are

usually found. Not all these leaks would necessarily give rise to faults during the next heavy rainstorm but a large number of cable failures are avoided.

When the Shrewsbury Exchange Area was partially pressurised at a cost of £1,000 before the floods of December, 1960, for example, more than 20 leaks were found and repaired. No faults occurred in the pressurised cables during the floods but the cost of repairs of faults which could have occurred had the cable not been pressurised was approximately £2,300.

The advantages of pressurisation are vitally important in keeping telephone cables in operation and experience has shown that in nearly all exchange areas where pressurisation has been introduced the cost has been considerably less than the savings achieved during the first year or so of service.

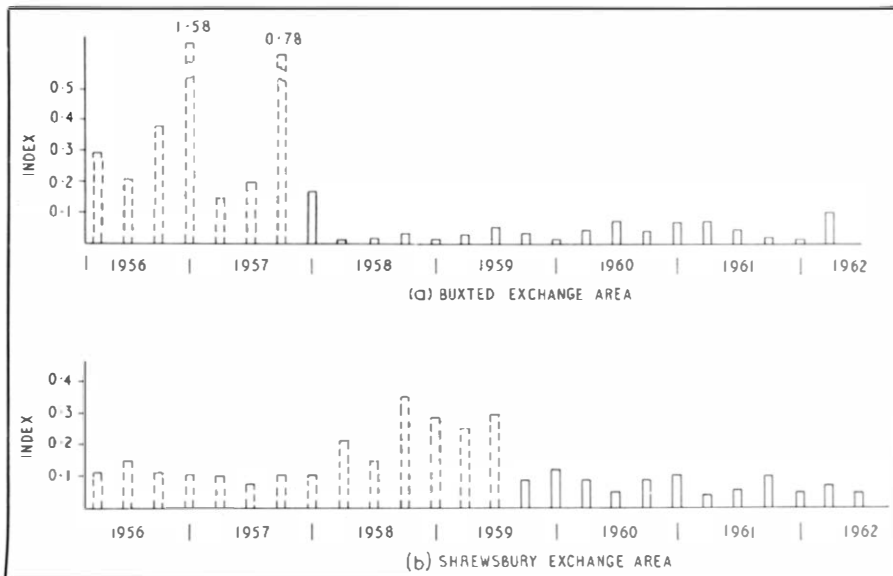

These two diagrams show the effect of pressurisation on the underground cable fault complaint per circuit index at three-monthly intervals in two exchange areas.

**This is the end product. Water cannot enter the fractured joint of this cable while the air bubbles from it.**



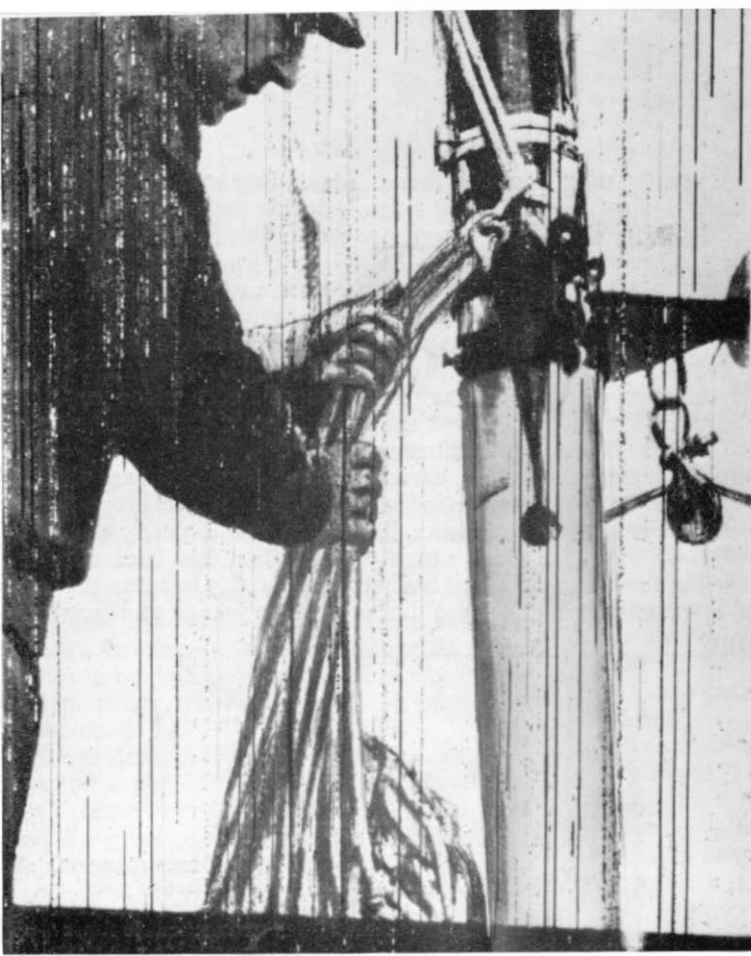

This first picture received from the *Rehu Moana* shows Mr. Merton Naydler, one of the crew, working on the ship's mast.



The *Rehu Moana* in the North Sea. In the Arctic she will collect valuable specimens.

## HISTORIC PICTURES FROM A SHIP AT SEA

**T**HE pictures on these pages—none of them has been retouched—make history.

They were sent recently to the London offices of The Guardian newspaper from the catamaran *Rehu Moana*, in the North Sea, over the Post Office's ordinary ship-to-shore radio-telephone service and the normal telephone system.

This is the first time photographs have been transmitted in this way from a ship at sea and the experiment was even more remarkable for being made from such a small ship and using only 75 watts of transmitted power—that is, about the same as that of a single electric light bulb.

The picture at top left was sent over the 2 Mc/s radio-telephone service to the Humber Radio Station from where it was forwarded by landline to receiving equipment in The Guardian's offices. The other two pictures were transmitted to Wick Radio Station several days later and then by landline to The Guardian.

The equipment used on board *Rehu Moana* consists of a Muirhead portable picture transmitter (Type D. 770) which works into a K. 99 AM/FM conversion unit to permit operation by radio. The



h Sea. During her expedition to  
valuable scientific information.



Charles McLendon, radio operator and second-in-command  
to the leader, Dr. D. Lewis, poses for his picture.

## FROM THE NORTH SEA

radio is a battery-powered Marconi Kestrel set.

These photographs are evidence of the excellent co-operation between the Post Office Marine Wireless Service, engineers of the Muirhead Company, Marconi Marine and The Guardian wire-room and telecommunication staff.

They also mark an important step forward in the Post Office policy of extending to ships at sea all the services available to telephone subscribers on shore. It is confidently expected that with more experience of transmitting pictures over the hitherto untried radio-telephone links, even better results will be obtained and that there will be considerable developments in the transmitting of pictures with small, portable equipment which, in turn, could lead to the opening of new radio-telephone services at sea.

During Rehu Moana's expedition to the Arctic this summer, the Post Office co-operated with the skipper, Dr. D. H. Lewis, in arrangements for the provision of information on radio communication. The expedition is expected to produce useful scientific observations on ice conditions, weather and oceanography and, possibly, some information on 2 Mc/s propagation conditions.

# LONDON'S TRUNK SWITCHING UNITS

★

By S. R. VALENTINE

**SINCE** the present arrangement of trunk telephone switching units in London contains a considerable legacy from the past it is appropriate first to take a look at the past so that the present and, to some extent, the future can be seen in proper perspective.

The concept of what constitutes trunk traffic has changed over the years, especially with the coming of trunk mechanisation, unified operating procedure, Subscriber Trunk Dialling and so on. All, other than local fee traffic, is now regarded as trunk traffic. Indeed, in London we go further than this because, in relation to the director area, there is traffic to and from the adjacent charge groups which, although local, is switched via centralised units which are still called toll units. These toll units are neither local nor trunk, but in this article they are treated as trunk switching units.

The most convenient point at which to begin a brief historical survey is immediately after World War II. Although plans were made before the war for the mechanical switching of trunk traffic, their development was largely suspended between 1939-45 but the proposals were reconsidered and modified for post-war application. As had happened in

**Diagram shows the make up of the London zone.**

This is the story of the many problems and of the plans for the future of the trunk telephone switching units in London

other fields, the war caused some parts of plans to be accelerated and others retarded. Thus, by 1945, some steps had been taken towards the mechanical switching of trunk traffic but the bulk of the traffic was still switched manually.

The post-war arrangements included a Trunk Director Exchange which was opened in the Faraday Building just before World War Two. Its

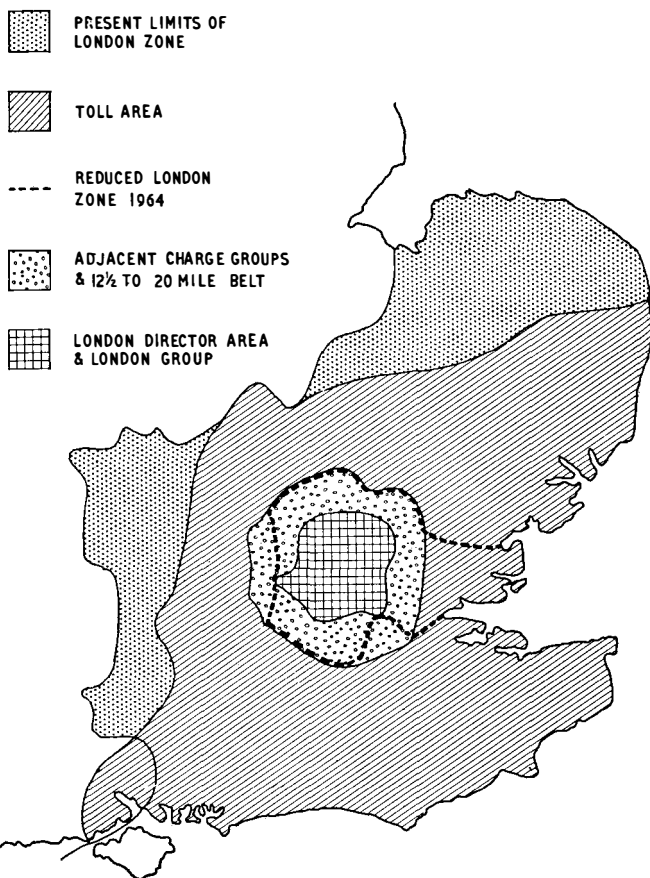

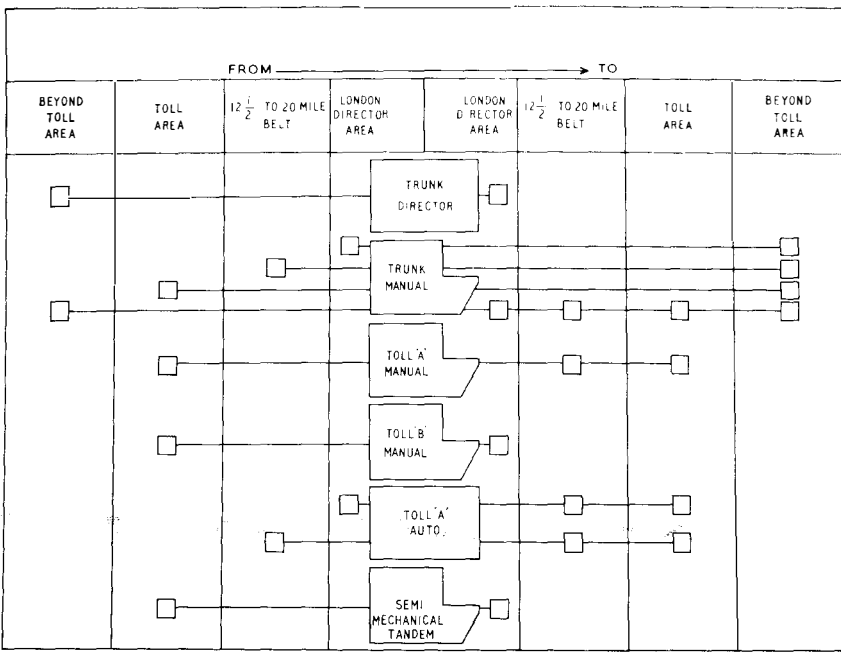

**This diagram shows the switching arrangements in London before World War Two.**

main function was to switch traffic to the London Director Area from distant zone centres. Access to the London Director Area from the Toll Area—very roughly a 70-mile circle about London—was given over routes to order wire 7-digit key-sender “B” positions in Holborn Exchange (Semi-Mechanical Tandem) or to the Toll “B” (incoming) manual exchange.

In World War II, Toll “A” (outgoing) automatic exchange was opened in the Faraday Building for switching traffic from exchanges within a 20-mile circle about London (Oxford Circus) to the Toll Area. Apart from this unit and Trunk Director exchange, the routing of trunk traffic needed the intervention of an operator either at London Trunk (Manual), Toll “A” (Manual), Toll “B” (Manual) or at Semi-Mechanical Tandem.

### The 1946 Plan

One of the most urgent post-war tasks was to evolve a new London Trunk switching plan for handling the rapidly growing volume of trunk and toll traffic and a programme was drawn up for decentralising control of this traffic and for mechanising its switching.

First, a new Toll “B” non-director exchange was to be opened in the Holborn building to switch traffic to the London Director Area from that part of the toll area lying beyond the 20-mile circle. It was to be a temporary exchange pending the provision of a large trunk non-director exchange in the Faraday Building, which was intended eventually to permit all exchanges outside the 20-mile circle

### The 1946 Plan for mechanising trunk switching. ►

to use a single route for both terminal and through traffic. Terminal traffic was to be that for the director area because the plan also provided for the reduction of the London Group (which then extended roughly to the boundary of the London Region) to the Director area by the opening of new group centres outside the 12½-mile circle.

A Toll “B” director exchange was also to be opened in Faraday building to replace Toll “B” manual and to permit the closing of the Semi-Mechanical Tandem exchange at Holborn. The Faraday Trunk Non-Director exchange would relieve Trunk Director of its long distance role thus enabling that exchange to be closed and the service area of Toll “A” to be reduced to the 20-mile circle.

The straightforward nature of the 1946 plan is illustrated by the following diagram: This shows that Trunk Director exchange has disappeared as has manual switching (as distinct, of course, from

OVER

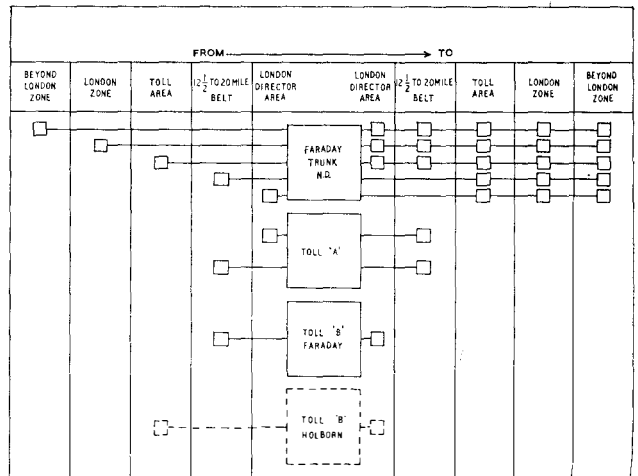



London units—Faraday Trunk Non-Director Outgoing, Kingsway Trunk Non-Director or Toll “A” Non-Director exchange. STD traffic coming into London, is dealt with at Trunk Director and Faraday Trunk Non-Director Incoming exchange which has been partially equipped with incoming register-translators.

### The 1962 Plan

What does the future hold? In the modified 1946 Plan it had been foreseen that relief to the Kingsway unit would be provided by reducing the London zone to the director area plus most of the adjacent charging groups and a few non-adjacent groups to the east. The rest of the old London zone would be served by three new zone centres—at Reading, Cambridge and Tunbridge Wells—which are due to open in 1964. It has now been accepted in principle that the London zone should be further reduced to coincide with the London charging group—that is, the director area—thus virtually eliminating London as a through switching centre. This process will be spread over a number of years, progress depending upon the provision of the necessary building space and equipment at the new zone centres.

The original plan for reducing the service area of Toll “A” to the 20-mile circle will be implemented. Any cross-London traffic will be transferred to Kingsway so that Toll “A” will switch only traffic going out from the Director area to the adjacent charging groups. It will then become the reciprocal of Toll “B” at Faraday. Toll “B” at Holborn, at present a purely non-director unit, will be extended, equipped with incoming register translating facili-

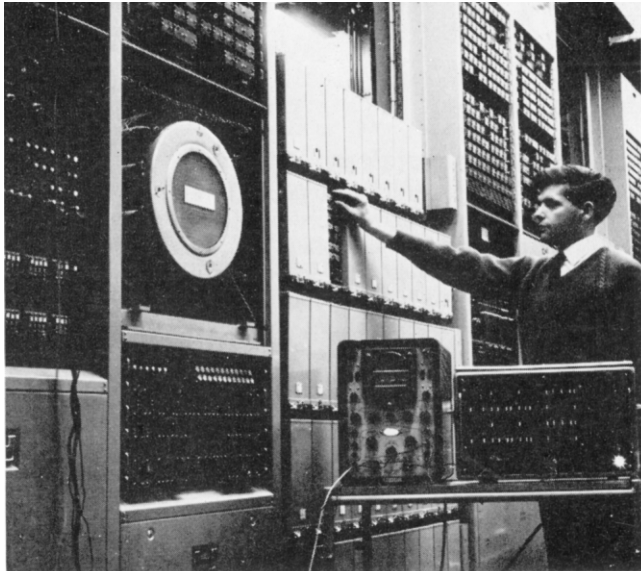

The magnetic drum type register-translator at the Citadel outgoing trunk exchange.

ties and renamed “Maxwell”. It will eventually perform a parallel role to Toll “B” at Faraday for switching traffic from adjacent charging groups into the director area but for a short time it will continue to handle traffic from beyond the 20-mile circle as it does at present.

Closure of Trunk Director exchange is included in the 1962 Plan, but it will not be possible to dispense with its capacity until 1969 at the earliest.

The picture which will emerge from the 1962 plan is shown in the diagram overleaf, in which units with similar or identical functions have been grouped together. The largest outgoing Trunk unit—Faraday Trunk Non-Director—is now, however, supplemented by an almost equal amount of non-director switching capacity in the Tower unit.

There is one mixed unit, Kingsway—Toll “A” now having been reduced to its ultimate role. Making use of these units are four centralised outgoing register-translator units. The first three are the existing unit, Citadel; Fortress due to open at Fore Street in the Spring of 1964; followed by Tower in the new Howland Street building in late 1965. Fortress was injected into the plan when it became apparent that the rapid growth of traffic would exceed the capacity of Citadel long before the Tower unit could be ready.

The name Bastion for the fourth unit which will be housed in an extension to the Temple Bar exchange building and should open in 1968, is not yet finally approved but it is in keeping with the principle of naming this type of unit after fortifications.

OVER

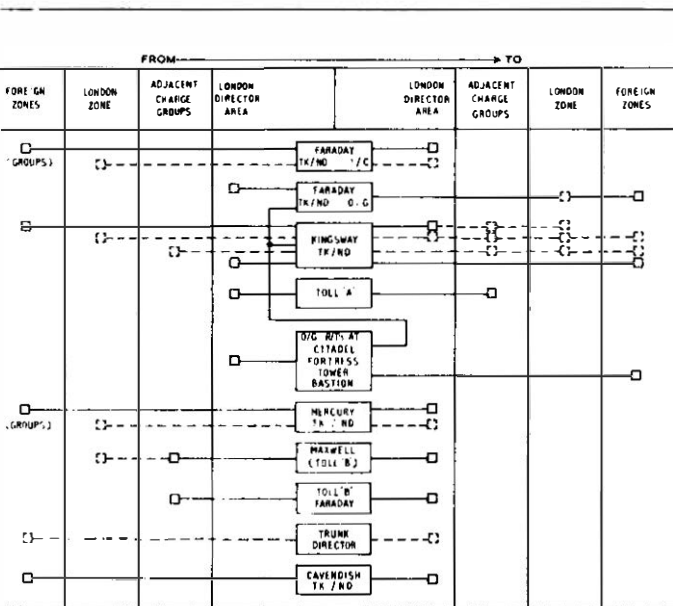

Left: Diagram shows the 1962 plans for future trunk switching in London.

## TRUNK SWITCHING UNITS *(Concluded)*

The trunking arrangements of all four units have been designed on similar lines. Each will have direct routes to all distant zone centres and certain large group centres. To make use of the direct routes from the London outgoing trunk units to CSCs in the provinces, traffic to these places will circulate via link routes to the Faraday and Kingsway units. Since it has been necessary, however, to provide further outgoing relief, extra stages of non-director switching will be built on to the Tower unit and these will dispose of some traffic circulating through the centralised outgoing register-translating units.

As soon as there are two or more outgoing register-translating units in operation there arises the problem of how best to use them to serve the large number of exchanges in the Director area (at present 224). The simplest plan would be to connect any one exchange to any one particular register-translator centre, perhaps on a geographical basis. This would be ideal from a cable provision point of view but it would mean that a failure of one of the units would completely interrupt out-

## THE AUTHOR

Mr. S. R. Valentine is a Deputy Telecommunications Controller in the London Telecommunications Region. He entered the Post Office in 1929 as a Youth-in-Training at the Research Station, Dollis Hill and in 1932 became an Assistant Superintendent of Traffic, Class II, in London. Following a period as Temporary Higher Executive Officer in the Establishments and Organisation Department of Post Office Headquarters he was promoted in 1952 to Chief Telecommunications Superintendent in the Manchester Area, being appointed to his present post in 1962.

incoming trunk units. The first will be Mercury, in the new Howland Street building, which is due to open towards the end of 1965. Mercury, with Faraday Trunk Non-Director (Incoming) and Trunk Director should meet requirements until about 1969 when another new incoming unit on a site at Houndsditch is to be provided. It is proposed to call this unit Cavendish in line with the decision to name incoming non-director exchanges after scientists. The Cavendish site should provide capacity for 20,000 trunk terminations, thus

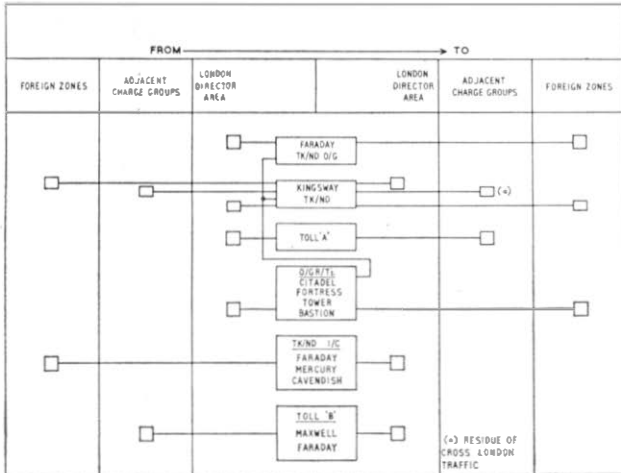

going STD traffic from a large area of London. To avoid this, most director exchanges will have their access junctions split between any two register-translator centres.

On the incoming side, Trunk Director should have disappeared by 1970. Faraday Trunk Non-Director (Incoming) will be supported by two other

**The Post Office Radio Tower. The Howland Street building associated with the tower will be equipped with new trunk switching equipment. The microwave mast (right), which the Radio Tower replaces, will be pulled down.**





allowing Trunk Director to be closed and avoiding some of the difficulties of recent years, such as the strait-jacket of limited space which has forced us into having a multiplicity of relatively small units in different buildings when we would have preferred to have had buildings with a much larger equipment capacity.

The present plans also envisage that trunk circuits on routes carrying STD traffic into London will be spread over the Mercury, Faraday and Cavendish units and, for a time, Trunk Director exchanges. Proposals for some form of rationalisation of the split of circuits between units are still under consideration. It is thought, however, that incoming traffic from operators will be handled by the Kingsway unit which, so far as can be seen at present, will not be equipped with incoming register-translators.

The diagram below gives a rough indication of the overall capacities of the London trunk and toll units, together with estimated requirements. The five graphs show a more favourable position

than can be achieved in practice since it is seldom possible to aggregate capacities of units fulfilling apparently similar functions because of such things as diverse signalling conditions. It can be seen that London will continue to face capacity shortages in the next two or three years resulting from the accelerated rate of traffic growth which took place after 1959 and because brought-into-service dates of relief units tend to be later than planned. In spite of a number of expedients designed to bridge the gaps in capacity the shortages will mean the continuance of such measures as the rationing of incoming terminations, deferments in the programme of STD conversions and limitations on subscribers STD access.

It is hoped that most of the difficulties will be over in 1965 when the new units—Tower and Mercury, in the Howland Street Building—are expected to be brought into service. The Howland Street Tower is a symbol of recovery and those engaged in long-distance planning take heart as they see it rising on the sky-line.

**This diagram shows the relationship between estimated traffic and unit capacities.**

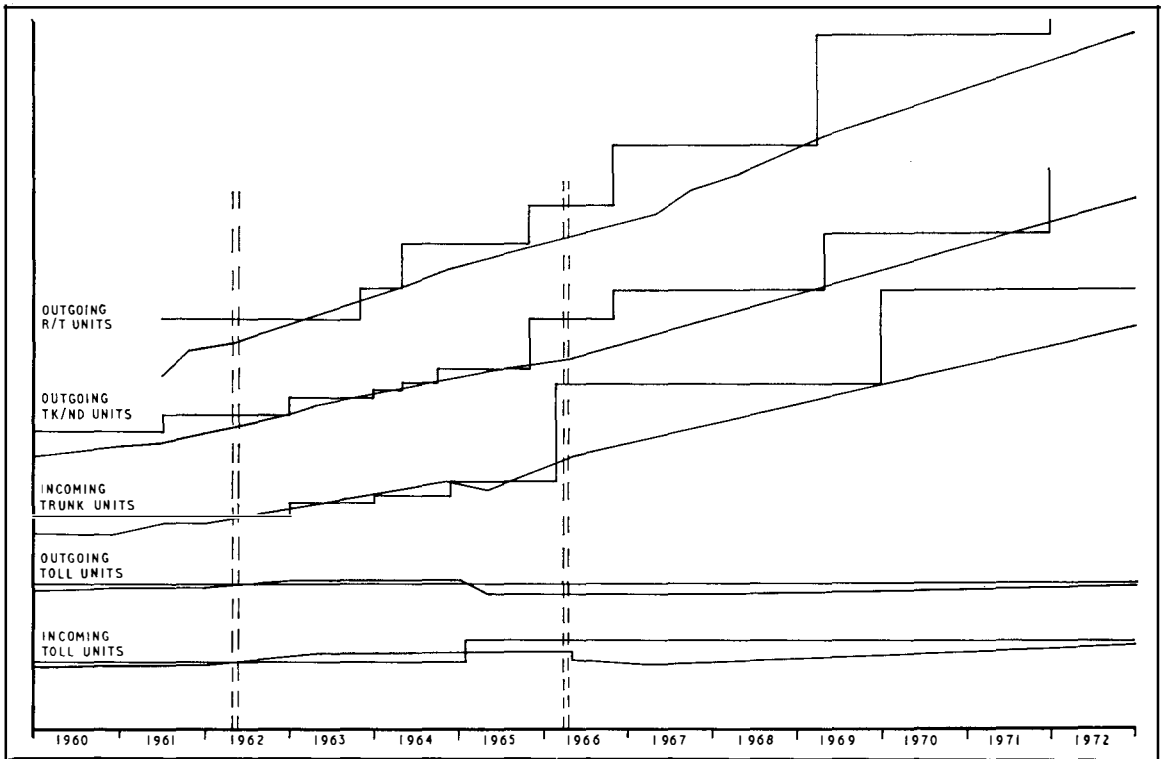

## Satellite Round-up

**TELSTAR I**, which celebrated its first birthday in space on 10 July this year, now has a younger, but tougher and higher-flying brother: *Telstar II*, launched on 8 May.

*Telstar II* weighs 175 lb (slightly heavier than *Telstar I*) and is more heavily protected against radiation. Transistors in one of its electronic systems have been pumped free of gas to prevent ionisation by particles in the Van Allen radiation belts, the cause of a failure in *Telstar I* which, though now silent, is still circling the earth.

*Telstar II* is in orbit at almost twice the height achieved by *Telstar I*, reaching a maximum range of 6,559 miles above the earth and coming to within only 595 miles at its lowest point during its elliptical journey.

Designed and built by the American Telephone and Telegraph Company, *Telstar II* is to be used for experimental communication links between the United States, Britain, France, Germany, Brazil, Italy and Japan. It has already been used to receive and transmit a large number of signals and carried television pictures of the coronation of the Pope and President Kennedy's recent visit to London. *Telstar II* may be used in 1965 to transmit television programmes of the Olympic Games in Japan.

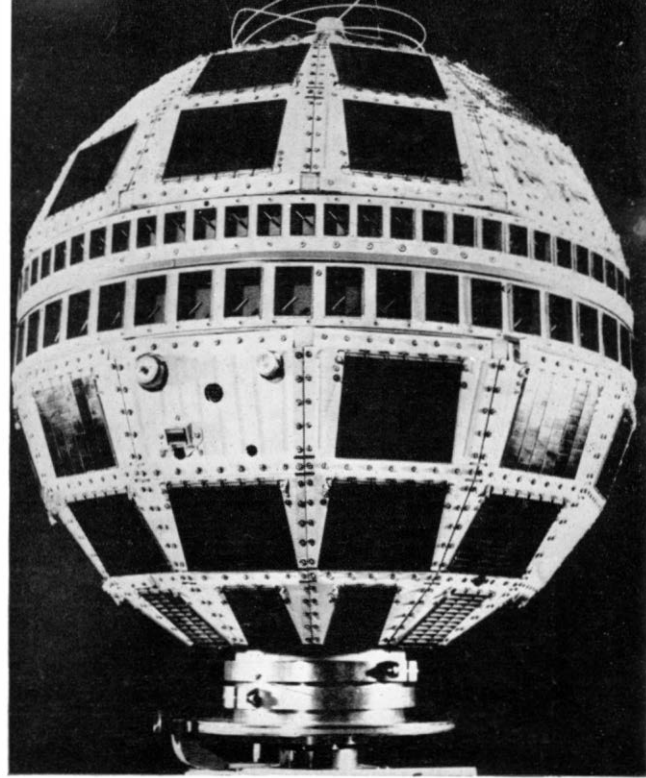

*Telstar II*. One of its tasks is to discover how to extend the useful life of a communications satellite in space by avoiding or overcoming radiation effects. It is circling the earth once in every 222 minutes.

## A TELSTAR TWICE AS HIGH



TELSTAR I and II  
Typical Orbits May, 1963

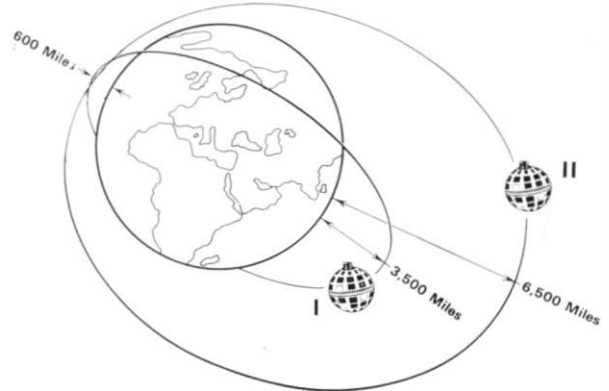

Left: Some of the transistors used in *Telstar II*. They were kept in vacuum jars to prevent moisture reaching them. Above: Showing how *Telstar II* will orbit the earth at twice the height of *Telstar I*.

# AND NOW—A SECOND SYNCOM

**ON 26 July, a few days before this issue of the *Journal* went to press, the United States' communication satellite *Syncom II* was successfully launched into orbit at a height of 22,300 miles.**

This new satellite—which will orbit at about the same speed as the earth's rotation so that it will

appear to hover in the sky—will be able to transmit one two-way telephone conversation, teletype messages and photo facsimile. It does not carry sufficient channels for television. A number of communications tests, which are being conducted mainly between a ground station at Lakehurst, New Jersey, and a satellite communication ground station ship, the *Kingsport*, in Lagos Harbour, Nigeria, have already been successfully completed. *Syncom II* transmits to ground stations at a frequency of 1,815 Mc/s and receives at two frequencies at about 7,360 Mc/s.

*Syncom I*, launched last February, failed to function. One reason may have been a power hitch. To overcome this danger in *Syncom II* a small battery providing power for up to 40 minutes, has been installed in case the regular supply is cut off.

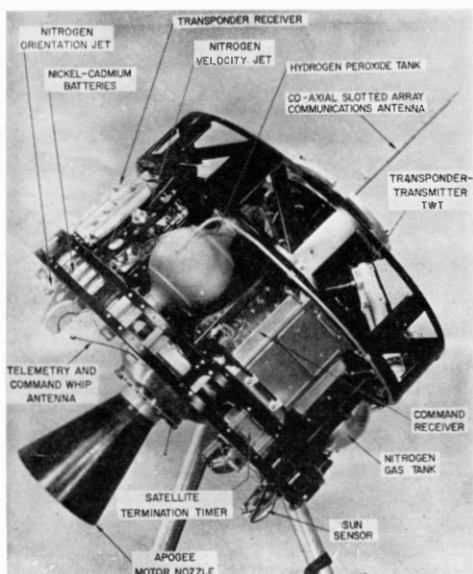

◀ *Syncom II*, with its solar panels removed and showing all the important details. This new communications satellite weighs only 86 lb.

## TELETYPE BY SATELLITE

**THREE** newspapermen in Chicago filed stories for their papers in Britain. Seconds later the stories were fed by teletype circuit into a computer at Camden where each line, word-spacing, hyphenating and so on were automatically adjusted to fit each newspaper's format.

Almost instantaneously the stories, now in code form, were sent to the United States' National

Aeronautic and Space Administration's satellite communication ground station at Nutley, New Jersey, and from there signalled to the satellite *Relay I* which passed them on to the British Post Office Ground Station at Goonhilly.

Moments later, the stories were on their way to the three newspaper offices where they were immediately converted into metal type ready to be placed straight into the pages of the newspapers.

The three stories, which were sent across the Atlantic by way of *Relay I* on 11 June, were the first press messages originating in one Continent to be automatically and almost instantaneously set in type in another.



## ***HOW THE POST OFFICE KEPT THE PRESIDENT IN TOUCH***

Setting up a communications network for President Kennedy, his staff and the Press when he visited England was like a wartime operation. The Post Office tackled the job at great speed and won the thanks of the Prime Minister

**B**ARELY a fortnight before President Kennedy's recent visit to England, the Post Office was called in to set up an extensive communications system to keep the President, his entourage and accompanying Press representatives in contact with the outside world.

The magnitude of the task and the speed at which it was completed was reminiscent of similar commitments in wartime days. That it was completed in time and worked so successfully reflects great credit on all who helped to plan and put the scheme into operation.

The President's acceptance of the Prime Minister's invitation to visit him at Birch Grove was announced on 7 June but it was not until 13-14 June when Mr. Pierre Salinger, Mr. Kennedy's Chief Press Officer, arrived in England that it was decided to set up a headquarters for the bulk of the Presidential party and Press at Brighton. The first the Post Office knew that the Americans wanted to set up a "White House" communications centre somewhere in Brighton was at a meeting called on 14 June. An initial plan, later greatly expanded, was provided and immediately the possibilities of producing the many and varied lines needed were investigated. Within a few hours it was decided that all requirements could be met at the locations specified in Brighton and the same evening the American communications liaison officer moved his headquarters there.

The disposition of the main centres to be used during the President's visit was such that the communications centre—at the Grand Hotel,

Brighton, with allied services such as the Press in the neighbouring Metropole Hotel—was 25 miles away both from Birch Grove, where the President was to stay, and from Gatwick, where the President's plane was to arrive and depart. This increased very appreciably the complexity of the task.

The primary consideration, therefore, was to provide an extensive network of external extensions and private wires radiating from the Grand Hotel, not only to Birch Grove and Gatwick but also to places as far away as Washington. In addition, members of the President's party accommodated at a number of country hotels scattered through mid-Sussex had to be connected by external extension to the central switchboard at the Grand Hotel. A survey of the various locations was made to determine the optimum siting for switchboards and telegraphic apparatus and the task of installation was made easier by the helpful co-operation of the hotel managements.

The installation at the Grand Hotel communications centre comprised two 10 + 50 switchboards which, with attendant power plant, were installed in one of the ground floor rooms. From this board radiated private wires to Washington and circuits to Admiralty House, the United States Embassy, Birch Grove, Gatwick Airport, the United States Air Force Headquarters at Ruislip and the various country hotels as well as 30 internal extensions to the hotel suites used by the visitors. Link lines to the Metropole Hotel were also provided.

The telegraph link-up consisted of an international circuit from the Grand Hotel to Washington and a teleprinter circuit from the Grand Hotel

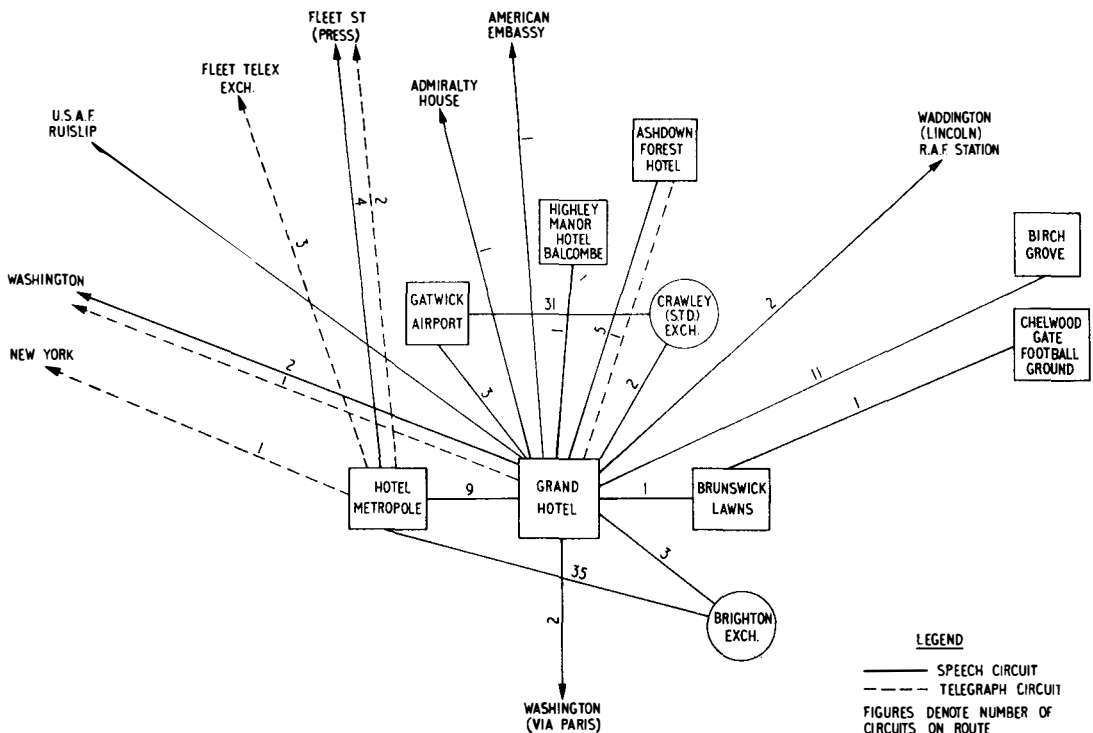

**This diagram shows the circuit layout of the telephone and telegraph arrangements for the President's visit.**

to the Ashdown Forest Hotel. Press offices and agencies also rented teleprinter circuits.

In the Metropole Hotel the main banqueting hall was converted into a Press conference arena and an adjoining room was cleared of furniture and filled with long tables on which 30 telephones with acoustic hoods, all working direct to the Brighton Automannual Switchboard on trunk subscribers' circuits, were mounted for the Press correspondents' use. Twenty-five were direct through to the switchboard and used by correspondents with credit cards or transfer charge facilities. The other five functioned as attended call offices for the benefit of correspondents who paid cash for their calls. In addition, there were six silence cabinets housing telephones connected directly to Press agency offices. Five speech and five teleprinter lines were provided to London for Press use and there was a direct telegraph circuit to New York.

Detailed instructions to the Press on the use of the telephones were drawn up by the Brighton Area traffic staff and distributed to correspondents by the Foreign Office. At no time during the visit was there any difficulty.

The existing local cables serving the two hotels were, of course, inadequate to provide all the additional circuits required. Luckily a development scheme for that neighbourhood was nearing

completion so that it was possible within a few days of the requirements being known to advance progress and joint in short additional lengths of cable. This provided sufficient circuits to meet all requirements and to afford alternative routings by way of the Brighton and Hove exchanges.

A helicopter shuttle service set up between Birch Grove and Brighton used one of the ornamental lawns on the sea front at Hove as a landing ground. Circuits were provided from the Hove landing ground both to the Grand Hotel switchboard and also to the RAF control post at Birch Grove. The telephones at the Hove end were housed in a joiner's tent and the only hitch in the whole operation occurred when the cable there was cut on the all-important Saturday. However, rapid attention by the jointing staff prevented any failure of operational communication.

At Gatwick the main task was to provide telephone facilities for the Press. Here, in a marquee, a set-up similar to that at the Metropole Hotel, Brighton, was installed, with 30 telephones in acoustic hoods connected to trunk subscribers' lines on the Crawley Automannual switchboard. As at Brighton, 25 circuits worked directly to the automannual switchboard and five were controlled by call office attendants.

OVER

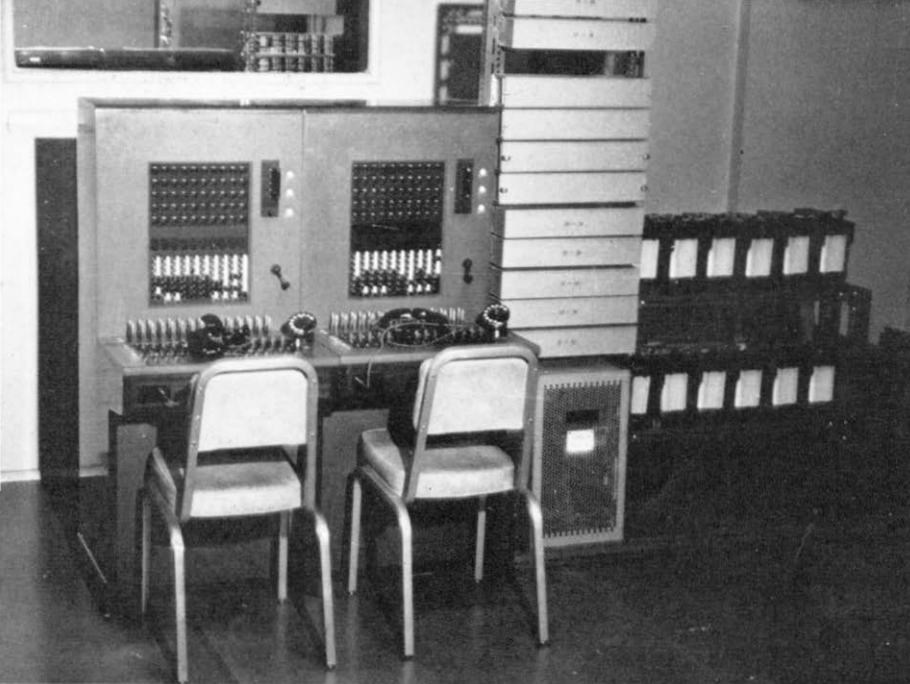

The two switchboards which were installed at the Grand Hotel, Brighton—the communications centre.

#### THE PRESIDENT (*Contd.*)

Because of the number of trunk subscriber circuits required additional relay sets were installed at both Brighton and Crawley. These were obtained from neighbouring exchanges. The resources of the Area were insufficient to meet all needs, however, and some equipment had to be borrowed from other Areas in the Home Counties Region.

Direct Press lines for both speech and picture transmission to many London agencies and 17 lines for the British Broadcasting Corporation were also provided and a further long distance circuit connected Gatwick with the United States broadcasting system at Washington.

The American authorities asked that as soon as the President's 'plane had landed, two circuits (one capable of extension to Washington) from the Grand Hotel board should be joined to apparatus inside the aircraft so that if necessary Mr. Kennedy could speak with his headquarters before leaving it. Two external extensions from the Brighton switchboard were accordingly terminated on coils of flexible cable sited at the periphery of the Gatwick VIP enclosure where the 'plane would come to rest. A lineman, with an American 'plane guard, was to run out and connect up to terminals in the aircraft's nose. This, in fact, is what happened and the operation was successfully completed. A similar procedure in reverse was put into effect on the President's departure.

Because of the operational importance of these two last-minute circuits it was decided to guard

against accident by providing alternative routing across the airfield. The switching panel was duly mounted in a jointer's tent in the landing area. At the last moment it was learned that the tent would be in line with one of the *Boeing's* jet intakes and stood a good chance of being drawn into the engine. The panel and its cables were rapidly transferred to a Jeep and driven to safety!

At the Prime Minister's residence at Birch Grove the telephone system had to be rearranged to cater for the needs of the President and his immediate personal staff. In addition, the Tunbridge Wells Area was called upon to devise and install circuits for the exclusive use of the security guards. To help the security police charged with the safety of the house, an omnibus circuit was provided to join all peripheral guard posts, thus enabling rapid communication between any single or group of points to be made.

The President's wish to attend a church service also raised a security problem. This was solved by laying a pair of wires to a policeman's house opposite the church and connecting a magneto telephone. A group of American Secret Servicemen were thus able to keep in contact with those at the main house.

A few days before the President arrived in England the communications plan was greatly expanded. Not the smallest headache was the late decision to divert the President's 'plane to Waddington RAF Aerodrome before its arrival at Gatwick so that Mr. Kennedy could visit his sister's grave. Similar

An engineer tests the 30 telephones which were provided for the Press in the Metropole Hotel.



arrangements to those at Gatwick had to be made at Waddington to connect the aircraft to external extensions to the Brighton switchboard.

The Americans were most co-operative at all stages in planning and executing this exercise and

the operation went off most successfully from the communications point of view. The Prime Minister sent a memorandum to the Postmaster General expressing his thanks for the excellence of the arrangements.

POSTMASTER GENERAL

I fear that President Kennedy's visit to Birch Grove last weekend gave your department a great deal of work. In the event all the arrangements were excellent and I know that the President and his party were much impressed by the efficiency of what was done. I should be grateful if you would convey my thanks to those concerned, especially to Mr. Walmsley for his work as co-ordinator, and to Mr. Meiklehan for his work in connection with the communications in the Birch Grove area, and to Mr. Welstead for the communications at Brighton and Gatwick.

A photo copy of the personal minute which the Prime Minister, Mr. Harold Macmillan, sent to the Postmaster General, Mr. Reginald Bevins, on 2 July, thanking the Post Office for its excellent work.

THE POST OFFICE IS VERY MUCH ALIVE TO THE VALUE OF STIMULATING BUSINESS FIRMS TO TAKE A LIVELY INTEREST IN THE EFFICIENCY OF THEIR OWN SWITCHBOARDS AND PARTICULARLY IN SEEING THAT THEIR OPERATORS ARE WELL TRAINED. RECENTLY THE POST OFFICE PRODUCED

# THE VOICE OF HOOVER



Mr. R. L. Webster, of Hoover's Head Office, presents the award for the runner-up in his Company's competition to Mrs. Helen Thomas.



**WHEN** the firm of Hoover Ltd. decided to organise a contest to discover its most efficient telephone operator it asked the Post Office for advice.

The Post Office jumped at the chance for it has always been concerned to do all it can to ensure that telephone operators employed by outside business and industrial organisations are well trained and fully conversant with operating procedures and practices. It offers free training, for example, to private switchboard operators and gives free advice to any firm which asks on how best to organise its internal telephone system.

The contest began when three judges—including Mrs. B. M. Jones, senior instructress at the Post Office's Private Branch Exchange Training Centre in London—made test calls from Hoover's Perivale factory to some 60 of the firm's telephone operators. The Post Office provided a special out-of-area line so that most Hoover offices could be contacted by STD. The few which could not be reached in

this way were contacted with the help of a London exchange where the supervisor ensured that the calls appeared to be of local origin.

The judges deliberately played the part of "difficult" callers and the operators were unaware that the calls were part of the contest. Marks were awarded for clarity, courtesy, pleasantness, company knowledge and general efficiency and as a result 12 girls entered the semi-final.

Later, local Post Office travelling supervisors visited each girl and gave her further tests, which included making recordings of selected expressions and phrases. From this evidence assessed by a combined Post Office and Hoover examining team, three girls were selected to compete in the final.

At a ceremony held at a London hotel and in which the judges included Miss Pat Simmons, the Post Office's new TIM Golden Voice, Miss Jean Hassard, from Belfast, was declared the winner and presented with a silver *Voice of Hoover* trophy and £50.



A BOOKLET ON THE THEME OF "THE TELEPHONE IN BUSINESS" AND WIDELY DISTRIBUTED IT AMONG INDUSTRIAL AND COMMERCIAL CONCERNS. THESE TWO STORIES TELL OF SOME OF THE FURTHER EFFORTS WHICH ARE BEING MADE TO ENCOURAGE EFFICIENT PBX SERVICES

# SHOWING THEM HOW IN MANCHESTER

**T**HE North West Electricity Board is another organisation which appreciates the need for its telephone operators to be efficient and for this reason the Chairman of the Board recently asked the Post Office to help organise a series of one-day courses for all their 60 PBX operators.

The courses, held at Dial House, Manchester's main telephone exchange, were voted an outstanding success and as one of the Board's operators said later: "It gave us a chance not only to see the latest telephone equipment but also how we fit into the national scheme of telephone communications."

Each course opened with a talk describing the facilities provided by the Post Office telephone service for its customers and was followed by the film "The 2d. Telephone" and a visit to the Millgate Trunk Control Centre. Later, a session was devoted to explaining Subscriber Trunk Dialling and new developments in subscribers' apparatus and this was followed by a talk describing the place of the PBX operator in the Electricity Board's organisation and how she can help the Board and its customers.

The last part of the course was devoted to a group discussion on the PBX operator's job, the qualities which are required of her and how she should handle various situations.



Above: Miss D. Burns, a GPO travelling supervisor, discusses new telephone equipment with PBX operators, who (bottom left) are shown over Dial House. Bottom right: Miss W. E. Hughes, GPO, Manchester, explains the working of a new type of switchboard.



## New Computers for the Post Office



**The Post Office has placed an order worth rather more than £1m for two new computers which will undertake a wide variety of work and, it is hoped, achieve a substantial saving in routine clerical work.**

The new computers, called the Leo 326 and made by English Electric—Leo Computers Ltd, will not be available until 1965 when one will be installed in London and the other at Lytham St Annes. To cover the gap between then and mid 1964, when some work will be ready for the new computers, a current type of Leo computer, the Leo III, will be installed on each site in mid 1964. Although this is a much slower machine it is in all ways “compatible” with the more powerful machine. This means that work being done on the Leo III can be transferred very easily indeed to the Leo 326.

This development is a big step forward in the Post Office’s plans to extend the use of computers. Plans have been made for the new computers to take on work for a number of Post Office departments. Initially they will be used in connection with the repayment of National Savings Certificates, dividend payments on Government stocks and bonds on the Post Office register and many of the operations in the Post Office Supplies Department and the Premium Savings Bond Office.

A number of other projects to be carried out by computer are also being studied; one is the Post Office field organisation, including telephone

**A general view of the LEO 111/1 installation at Hartree House showing the engineer’s console and computer cabinets on the left, and magnetic tape units on the right.**

*Courtesy: English Electric-Leo Computers Ltd.*

billing, costing, budgetary control, management control and forward planning.

The Leo 326 computer, which was chosen by the Post Office as a result of a carefully planned comparative survey of some twenty large-scale computers, is nearly six times faster than the Leo III computer which will be in use as a stopgap. It will have access to a memory of 200,000 characters in about two millionths of a second, be able to multiply two ten-digit numbers together in 53 millionths of a second and take logical decisions as to which alternative paths to follow in three millionths of a second. It can also work directly in pounds, shillings and pence, as well as in decimals or a number of other notations. It is also capable of performing more than one process simultaneously.

Like the Leo III, the Leo 326 will be equipped with a bank of magnetic tape decks holding the millions of records with which the Post Office has to deal, and take information from them at the rate of nearly 240,000 alpha-numerical characters a second. Processing this information is in general controlled by a very detailed step-by-step series of instructions—the programme—which has to be put into the machine. The machine contains, however, a number of special circuits which take over certain whole functions from the programmer. For example, one of these will take only 20 millionths of a second to discover whether a particular transaction refers to the next record on the magnetic tape file.

The printers which will be employed will be able to print lines of 160 characters at the rate of 1,000 lines a minute, and two printers could operate simultaneously on different tasks if necessary.



*The Ford Motor Company is to spend more than £500,000 on a scheme to link their 13 motorcar factories in Britain with a private telephone exchange which will be fully automatic and have nearly 8,000 extensions.*

*The nerve centre of the system, which will be one of the biggest private systems in the country, will be at Dagenham.*

Deep in Cannock Chase Forest stands the concrete shell of the new microwave tower which will rise to 258 ft.

*Courtesy: Holst & Co. Ltd., Watford.*

## A New Microwave Tower

*A new microwave tower and radio building for the Post Office is taking shape at Pye Green near Cannock, in Staffordshire.*

*The circular Tower, which will be 258 ft. high, varies in diameter from 45 ft. at the base to 32 ft. at a height of 189 ft. Above that level will be a 12 ft. diameter shaft, with three circular cantilever platforms. The horn and dish aerials, which will be supported on the three platforms, will be raised into position by a one-and-a-half ton electrically-operated crane. The concrete work was completed in April.*

*The new radio building will be a conventional single-storey steel framed structure, about 82 ft. long and 54 ft. wide.*

## COIN BOX WINS AN AWARD

The Post Office's new pay-on-answer coin box—described by the judges as a straightforward, well-integrated solution to a complex engineering problem and by its designer, Douglas Scott, FSIA as one of the most difficult jobs he has dealt with, has won a Design Centre award.

Already about 40,000 of these new coin boxes have been installed throughout the country and eventually, as Subscriber Trunk Dialling spreads, the old black box with A and B buttons will disappear. The new boxes are proving to be satisfactory.

## BIRTHDAY HONOURS

**Mr. A. H. Mumford**, OBE, Engineer-in-Chief, was honoured with a knighthood (KBE) in the recent Queen's Birthday List.

Mr. Mumford entered the Post Office in 1924 as an Assistant Engineer (Old Style) and worked at Dollis Hill on short-wave radio, multi-channel telephony and television transmission over co-axial cables. He was concerned with the development of the first transatlantic radiotelephone service. During World War Two he was in charge of the Radio Branch and has been Engineer-in-Chief since 1960.

Mr. Mumford is Vice-President of the Institution of Electrical Engineers and will become President



**Douglas Scott, the designer of the new coin box makes a call on one of the instruments.**

in October, 1963. In 1962 he became a Fellow of Queen Mary College.

**Mr. H. M. Turner**, Deputy Regional Director, London Telecommunications Region received the OBE and **Mr. S. W. Broadhurst**, Assistant Staff Engineer, Dollis Hill the Imperial Service Order.

**Mr. T. S. Wylie**, Senior Executive Engineer, Belfast, and **Mr. A. G. H. Armour**, Assistant Engineer, Liverpool, received the MBE.

The British Empire Medal was awarded to **Miss I. F. Hassell**, Chief Instructor, Telephonist Training Centre, London Wall; **Miss E. Keen**, Supervisor, Windsor; **Mr. W. A. White**, Technical Officer, Dundee Telephone Area; **Miss E. E. Henderson**, Assistant Supervisor, Enniskillen; and **Mr. J. C. Purdom**, Overseer, Post Office Cable and Wireless Services.

## Telecommunications Statistics

In this issue the figures presented are for the complete financial year to 31st March, 1963, compared with those for the two previous years.

	March 31st 1961	March 31st 1962	March 31st 1963
<i>The Telephone Service at the end of the Year</i>			
Total telephones in service ... ..	8,280,000	8,624,000	8,927,000
Exclusive exchange connections ... ..	3,894,000	4,084,000	4,254,000
Shared service connections ... ..	1,142,000	1,126,000	1,100,000
Total exchange connections ... ..	5,037,000	5,210,000	5,354,000
Call Offices ... ..	73,930†	74,250†	74,540
Local automatic exchanges ... ..	5,190	5,277	5,387
Local manual exchanges ... ..	811	733	624
Orders on hand for exchange connections ... ..	170,000	147,000	160,800
<i>Work completed during the year</i>			
Net increase in telephones ... ..	422,000	344,000	312,000
Net exchange connections provided ... ..	490,000	459,000	434,000
Net increase in exchange connections ... ..	253,000	173,000	145,000
<i>Traffic</i>			
Inland telephone trunk calls ... ..	422,000,000	475,000,000	543,000,000
Cheap rate inland telephone trunk calls ... ..	98,000,000	112,000,000	125,000,000
Overseas telephone calls:			
Outward ... ..	3,556,000	3,736,000	4,035,000
Inward ... ..	3,400,000	3,788,000	3,941,000*
Transit ... ..	83,000	95,000	99,000*
Inland telegrams (excluding Press and Railway) ... ..	12,472,000†	12,264,000†	11,727,000
Greetings telegrams ... ..	2,991,000†	3,056,000†	3,135,000
Overseas telegrams:			
Originating UK messages ... ..	6,369,000	6,477,000	6,318,000
Terminating UK messages ... ..	6,454,000	6,454,000	6,381,000
Transit messages ... ..	5,496,000	5,401,000	5,216,000
Inland telex calls ... ..	2m. calls from manual and auto. exchanges; 37m. metered units from auto. ex-changes.	77m. metered units; 10,000 manually hand-led calls.	99m. metered units; 10,000 manually handled calls.
Overseas telex calls ... ..	2,948,000	4,304,000	5,545,000

† Amended figures.

\* Includes some estimated figures.

### NOTES

*During the year the telephone order list increased from 147,200 to 160,800. At the end of the year 116,800 applications for service were in process of being met and 44,016 were waiting cables or exchange equipment.*

Are you a Square? — Or do you keep up to date with the

## TELECOMMUNICATIONS JOURNAL?

To become a subscriber costs you less than 1½d. a week

See your Sales Organiser now for details or write direct to:  
**The Editor, TELECOMMUNICATIONS JOURNAL, Public Relations  
 Department, Headquarters Building, General Post Office, LONDON, E.C.1.  
 Telephone: HEAdquarters 4345.**

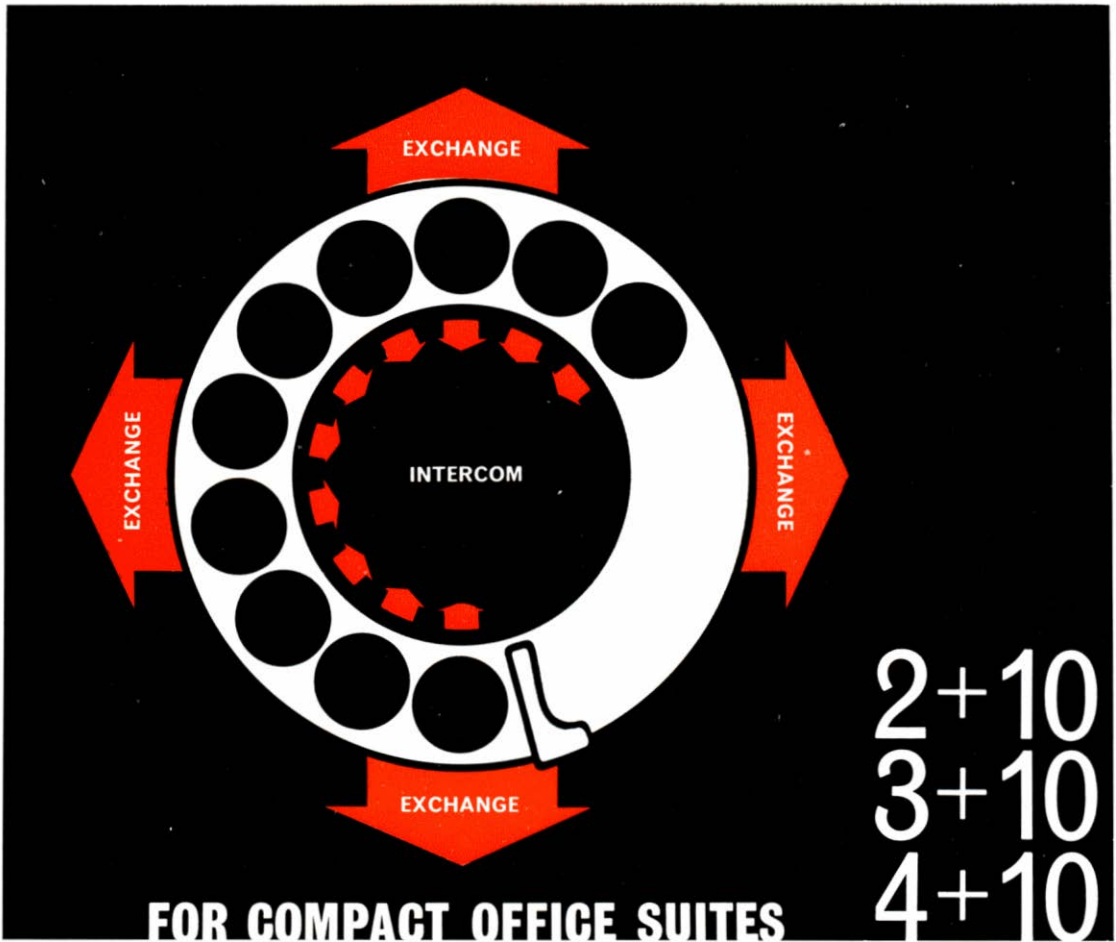

A vital aid to business efficiency in small organisations when compactness is the keynote, this miniature private automatic branch exchange offers advanced facilities, dependability and convenient operation with ease of installation. Provision is made for up to 10 telephones of the well known Plan-Etelphone type with intercommunication facility and individual access to 2, 3 or 4 exchange or P.B.X. lines. Connections are made via a multiple cable through a small control unit housing demountable relay units, terminating field and 24-volt mains operated power units. Other features include secret or non-secret intercom calling by selective dialling, exchange line holding and transfer, and positive lamp signalling at each station of all calls offered, held or in progress. Many other desirable features of this compact system are described in a booklet available on request from the address below.



**P.A.B.X.**

**ERICSSON TELEPHONES LTD**  
**ETELCO LTD**



# THE POST OFFICE KEPT THE SECRET

By Geoffrey Dorman

In 1956 test pilot Peter Twiss became the first man to fly an aeroplane at more than 1,000 miles an hour. Now in a new book—*Faster Than The Sun* (Macdonald, 30s.), he tells the story and reveals how the Post Office helped.

Since the United States, which already held the record at 880 mph, was planning to raise it, it was imperative that no hint that the British were preparing an attempt should leak out. So security arrangements like those for a wartime operation were laid on and only very few people closest to the project were in the know. A very

complicated system of communications had to be established along the record course between Portsmouth and Beachy Head leading up to the actual 15 kms speed course. Radio was used as much as possible for secrecy but much Post Office land line had to be used.

Twiss describes the great efforts made to prevent the secret leaking as the timing gear was installed. "At this stage," he says "we had to bring the GPO into it in a big way as we could no longer avoid the problem of communications. Vitally important was the provision of completely reliable communications between the two camera sites. The camera-timing mechanism on one hand had to be electrically connected with the camera-timing mechanism on the other . . . We went to the highest-ranking GPO official to whom we had access and told him what it was all about. By this time our imaginative approach towards cover stories was wearing a bit thin and we were relieved when he fell into the spirit of the thing and invented splendid cover stories of his own. . . . The whole communications system was networked through the ordinary GPO exchanges . . . with reliability, speed of operation, and security. The GPO were absolutely magnificent.

"I'll never forget going down one day to have a look at one of the camera sites and not believing my own eyes. Every telegraph pole and bush for half a mile or more was swarming with men with little green vans hanging wire up. Without any fuss they completed the whole job in a couple of days."

**Editorial Board.** A. W. C. Ryland (Chairman), Director of Inland Telecommunications; H. M. Turner, Deputy Regional Director, London Telecommunications Region; L. J. Glanfield, Deputy Regional Director, Home Counties Region; H. A. Longley, Assistant Secretary, Inland Telecommunications Department; Col. D. McMillan, C.B., O.B.E., Director, External Telecommunications Executive; H. Williams, Assistant Engineer-in-Chief; Public Relations Department—E. J. Grove (Editor); Miss K. M. Davis.

**Regional Representatives.** J. Sharp, North-Eastern Region; R. F. Bradburn, Wales and Border Counties; D. H. Thompson, North-Western Region; D. Davies, Northern Ireland; V. F. B. Medland, Home Counties Region; W. Handley, R. C. Friend, London Telecommunications Region; E. R. P. Chant, Scotland; L. Beeby, Midland Region; P. J. Hart, South-Western Region; J. E. Judson, Engineering Department.

**Publication and Price.** The *Journal* is published in February, May, August and November, price 1/6. The annual postal subscription rate is 6/6 to any address at home or overseas.

**Copyright.** Copyright of the contents of the *Journal* is reserved. Application for permission to reprint all or part of any article should be addressed to the Editor.

**Advertisements.** No official responsibility is accepted for any of the private or trade advertisements included in this publication. Communications, advertisement copy, etc., should be addressed to Sawell & Sons, Ltd., 4 Ludgate Circus, London, E.C.4. (Telephone: FLet Street 4353).

**Contributions.** The Editorial Board will be glad to consider articles of general interest within the telecommunications field. No guarantee of publication can be given. The ideal length of such articles would be 750, 1,500 or 2,000 words. The views of contributors are not necessarily those of the Board or of the Department.

**Communications.** Communications should be addressed to the Editor, Post Office Telecommunications Journal, Public Relations Department, Headquarters, G.P.O., London, E.C.1. Telephone: HEADquarters 4345. Remittances should be made payable to "The Postmaster General" and should be crossed "& Co."



## Economical Cross-Country Communications with the Seven Channel ATE Type 900.

The ATE Multi-Channel VHF/UHF Equipment has been specially designed for applications where a number of short or medium distance circuits are required between two or more locations. The equipment provides telephone operating companies with all the normal dialing, supervisory and metering facilities associated with manual and automatic public or private telephone networks, and can be integrated with line or larger radio multiplex networks.

The terminal consists of aerial filters, transmitter unit, receiver unit, power supply unit, multiplex equipment, and mains supply panel. The Multiplex apparatus conforms strictly to CCITT recommendations and provides six high grade carrier-derived speech circuits with out-of-band signalling, and an audio channel for use as an engineering control circuit. An automatic and/or manual changeover is also incorporated to give either local or remote indication of signal or equipment failure and switch the transmission through to a standby link.

The transmitter is frequency modulated and occupies a nominal band-width of 250 kc/s per system with an effective modulation baseband of from 300 c/s to 36 kc/s. The equipment is available for operation in the 156-184, 220-260, and 430-500 Mc/s bands and the nominal output power ranges from 5 watts to 150 watts as required.

The Type 900 Equipment is just one of a wide range of communication equipment built by AT&E, who also offer a comprehensive planning, surveying and installation service. If you would like more details, please write to :

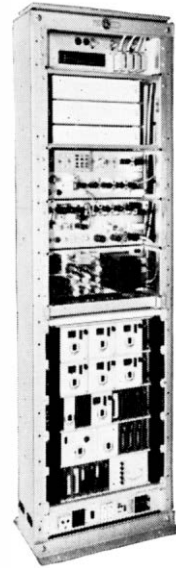

AT&E (Bridgnorth) Ltd · Bridgnorth · Shropshire · England

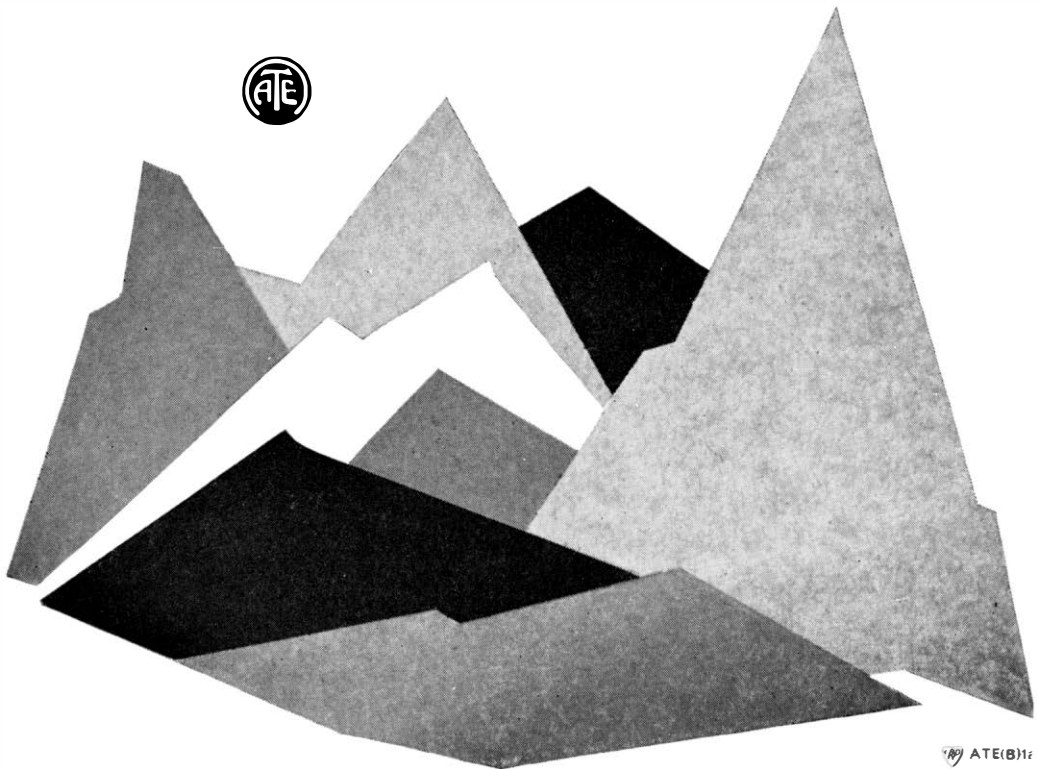

# STEPMASTER by STC



The new range of Stepmaster PABX's by STC provides efficient and fast telephone communication to meet modern business requirements. Operating procedure is so simple that the attendant can devote time to secretarial or receptionist duties in addition to handling calls.

- Push-button cordless type attendant's cabinet.
- Extension line capacity, 20, 50 or 100 units and 100-200 extensible.
- B.P.O. type "long life" components.
- 4000-type selectors.
- All "plug in" type equipment.
- Transistorized tone circuits.
- Switching equipment mounted in totally enclosed cubicle if required.
- Quick, easy expansion up to capacity.
- Simple installation and maintenance.
- Tropical finish.

Write, 'phone or Telex



*Standard Telephones and Cables Limited*

TELEPHONE SWITCHING DIVISION  
OAKLEIGH ROAD · NEW SOUTHGATE · LONDON, N.11  
Telephone ENTerprise 1234 · Telex 21612



# WHITELEY

## electronic equipment and components

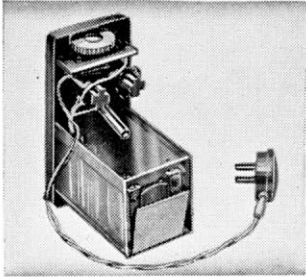

Potted components and assemblies in epoxy, Polyester resins and Polythene.

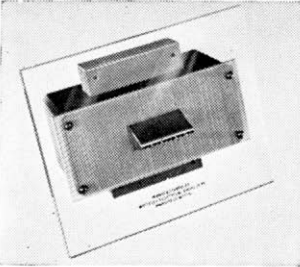

An astatic wound AF screened line transformer. Insulation of the line winding provides isolation against voltages of 30KV R.M.S.



P.O. Tester, AT5422 representative of the many types manufactured for the G.P.O.

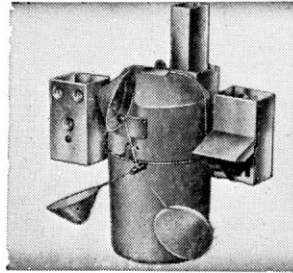

Radio Sonde Transmitter, supplied to British Meteorological Office and foreign governments.

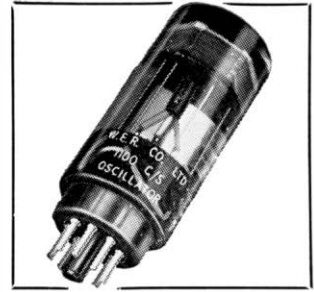

This fixed frequency oscillator is constructed on a standard octal base and encapsulated in epoxy resin.

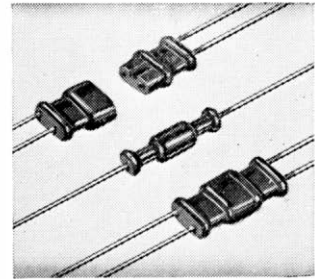

Waterproof plugs and sockets moulded in Polythene for underwater or outdoor installation.



The Post Office Tester is a multi-range meter used for making tests on subscribers' apparatus and lines.

The items shown here are representative of the extensive variety of products manufactured by the Whiteley organisation. Our technical resources are available for the development and production of specialised components for the electronic industry.

***get in touch with us NOW!***

**WHITELEY ELECTRICAL RADIO CO LTD**

MANSFIELD · NOTTS

Telephone: Mansfield 1762/5



## TELECOMMUNICATIONS CABLES

Pirelli General are in a position to advise on complete Telecommunications schemes and are organised to manufacture and install cables for distribution and trunk services; also carrier and all types of coaxial cables.

Pirelli General also manufacture cables to meet special requirements of Public Utilities or of industry.

**PIRELLI GENERAL CABLE WORKS LTD. SOUTHAMPTON TEL: SOUTHAMPTON 20381**

P9315

**WE'VE  
NEVER  
BEEN  
STUMPED!**

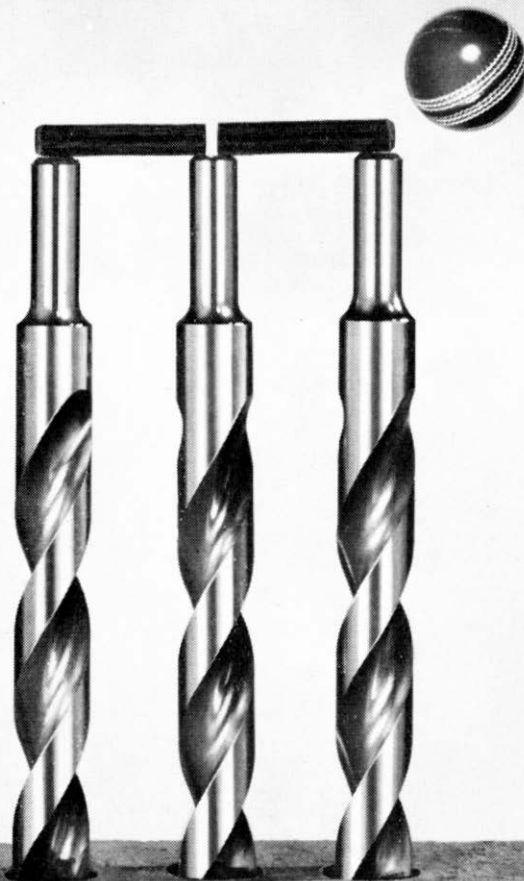

We thrive on fixing problems—far from letting them stump us, we use them as stepping stones to new techniques. For instance, as Rawlplug devices speeded up fixing methods on contract work a faster cutting drill became necessary. In solving the problem, we didn't make just a faster drill—we made the fastest cutting masonry drill in the world: the Durium Drill. Its tougher-than-tungsten tip cuts through every kind of masonry with really amazing speed. Just try one—and see the difference.



## **MASONRY DRILLS**

THE RAWLPLUG CO. LTD . CROMWELL ROAD . LONDON S.W.7



**COMBINED OPERATIONS  
WITH THE NEW  
MILITARY MANPACK SET**

**HF30**

The HF30 military manpack set is completely self-contained and portable, operating from an internal re-chargeable accumulator or dry battery.

The complete station is carried in a military-pattern haversack and is an extremely light and comfortable one-man load.



BRITISH COMMUNICATIONS CORPORATION LTD NEASDEN LONDON NW10 Tel: DOLis Hill 8511 Cables: Britcom London

**BRITISH COMMUNICATIONS CORPORATION LIMITED**

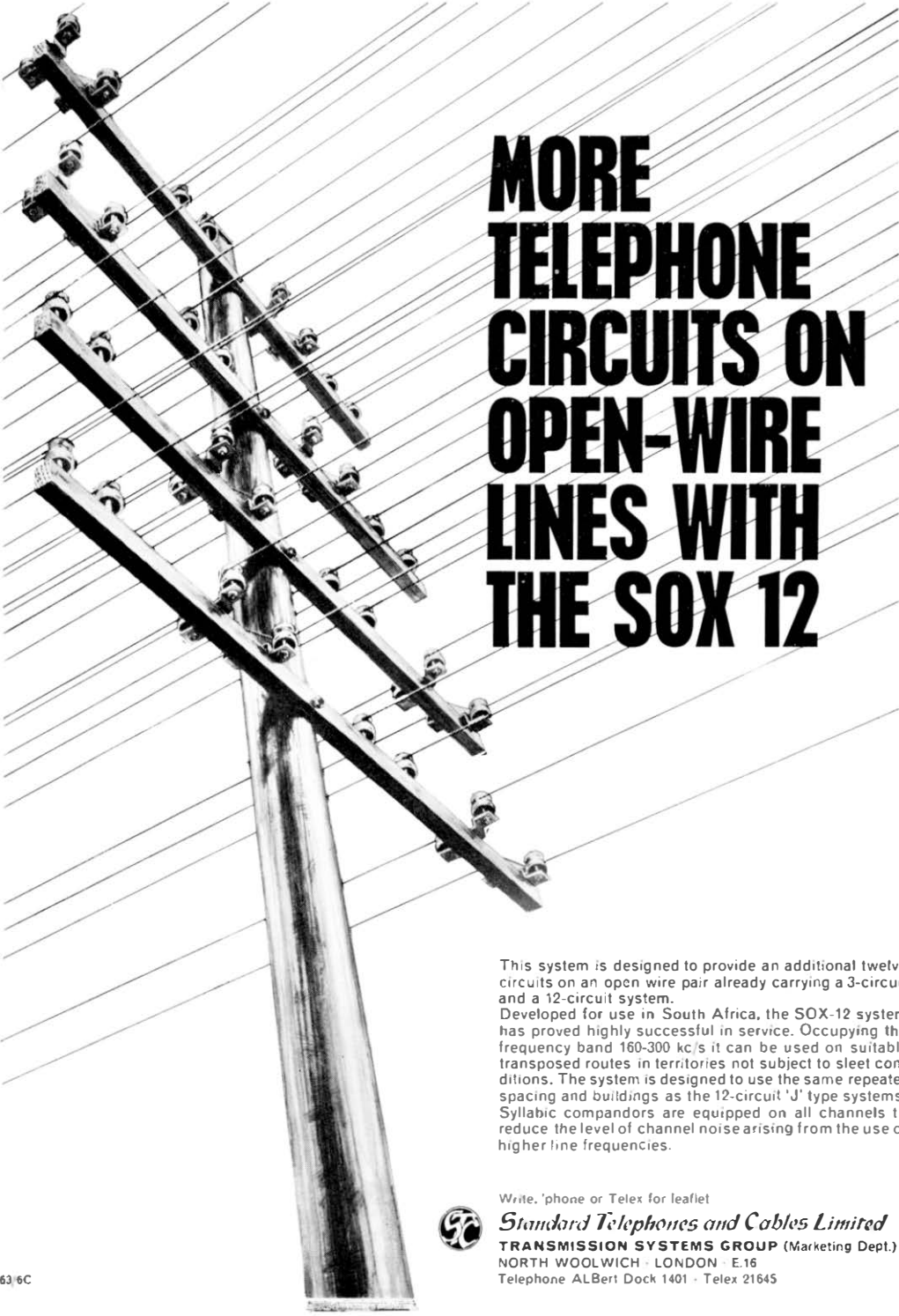

# MORE TELEPHONE CIRCUITS ON OPEN-WIRE LINES WITH THE SOX 12

This system is designed to provide an additional twelve circuits on an open wire pair already carrying a 3-circuit and a 12-circuit system.

Developed for use in South Africa, the SOX-12 system has proved highly successful in service. Occupying the frequency band 160-300 kc/s it can be used on suitably transposed routes in territories not subject to sleet conditions. The system is designed to use the same repeater spacing and buildings as the 12-circuit 'J' type systems. Syllabic companders are equipped on all channels to reduce the level of channel noise arising from the use of higher line frequencies.

Write, 'phone or Telex for leaflet



*Standard Telephones and Cables Limited*

**TRANSMISSION SYSTEMS GROUP** (Marketing Dept.)

NORTH WOOLWICH · LONDON · E.16

Telephone ALBERT Dock 1401 · Telex 21645

# delayed pulse and sweep generator

Rise Time less than 10nanosec  
 Pulse Height, Width and Delay independently variable  
 Wide Frequency range  
 True positive or negative pulse output  
 Sweep output gives jitter free oscillograms

*pulse width and delay* 0.09µsec to 105msec

*period* 0.9µsec to 1.05sec

*output* max. 5V in 75Ω, max. 50V in 1kΩ

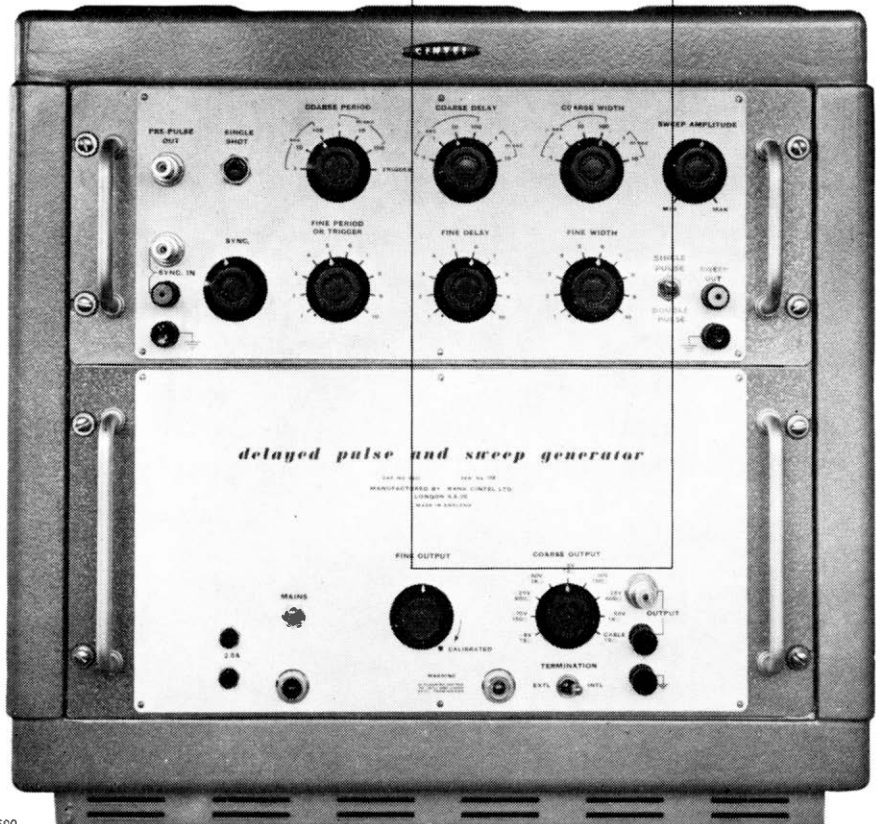

The Rank Organisation  
 Rank Cintel Division  
 Worsey Bridge Road  
 London SE26  
 Telephone Hither Green 4600

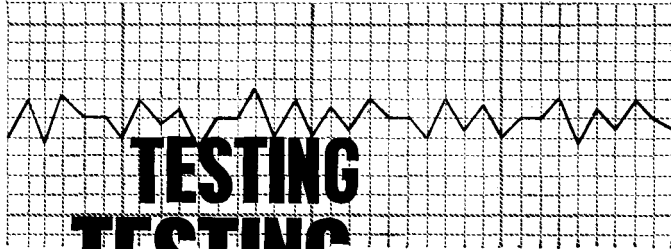

**TESTING  
TESTING  
TESTING...**

A continuous programme of testing, carried on day-by-day in the Painton Laboratories, forms the backbone of vital quality control processes.

These consist of a series of exhaustive procedures devised to ensure that Painton electronic components are manufactured from the best available materials, to yield the best possible performance.

The result is a built-in 'plus-factor' of great value to the electronic engineer who recognises that it is this background activity that

ensures  
**PAINTON**  
**RELIABILITY**

**Painton**  
& CO LIMITED  
KINGSTHORPE · NORTHAMPTON  
Tel: 34251 (10 lines) · Telex 31576  
Grams: 'Ceil' Northampton



**British Designed - British Made**

## **MICROPHONES TO KEEP FAITH WITH SOUND**

Lustraphone's very extensive range of microphones and accessories include models specifically designed to meet almost every requirement. Indoor use, and outdoors, for close talking, for heavy working conditions. Sound construction and design ensures an exceptional degree of reliability and service.

Designers and manufacturers of dynamic and ribbon microphones. Microphone accessories. Microphones for telecommunication. Radio microphone systems. Transistor amplifiers. Transistor portable public address systems. Noise-cancelling intercommunication systems. Ancillary equipment.

**ILLUSTRATED BROCHURE ON REQUEST**

## **LUSTRAPHONE LTD.**

**ST. GEORGES WORKS, REGENTS PARK ROAD, LONDON, N.W.1**

Telephone : PRImrose 8844



Contractors to the G.P.O.

NATIONAL COAL BOARD

BRITISH RAILWAYS

C.E.G.B. and

BRITISH & DOMINION GOVERNMENTS DEPTS.

# **HACKBRIDGE CABLES**

HACKBRIDGE CABLE CO. LTD.

KELVIN WORKS,

HACKBRIDGE, SURREY

Phone: FRAnklin 1101.7



# IMPROVE YOUR TELEGRAPH MESSAGE HANDLING WITH "AMATI" THE NEW STC/CREED TAPE RELAY TELEGRAPH SYSTEM

## FACILITIES OFFERED INCLUDE:

AMATI—Advanced Manual Automatic Tape Interconnector, compatible with all-electronic systems, is designed for use in locations where the expense of more sophisticated telegraph systems cannot be justified. STC Switching Techniques and Creed Telegraph machines combine to give efficient and high speed routing of telegraph messages.

- High Speed Cross-office transfer.
- Universal operation—(mixed if required) i.e.
  - (a) Torn tape—Semi-Automatic Routing.
  - (b) Continuous Tape—Semi-Automatic Routing.
  - (c) Continuous Tape—Automatic Routing.
- Centralized operating positions for Manual Routing systems resulting in high operating efficiency.
- Mixed receiving and transmission speeds—depending on the speeds of the particular circuits concerned.
- Electronic circuitry combined with simple electro-mechanical switching.
- Automatic checking of incoming serial number.
- Automatic Generation of message heading e.g. Serial numbering, date & time transmission.
- Permanent record of messages.
- Individual Storage of incoming Duplex lines on continuous Tape Systems.
- Common Pool Outgoing Storage (each store catering for at least 36,000 characters).

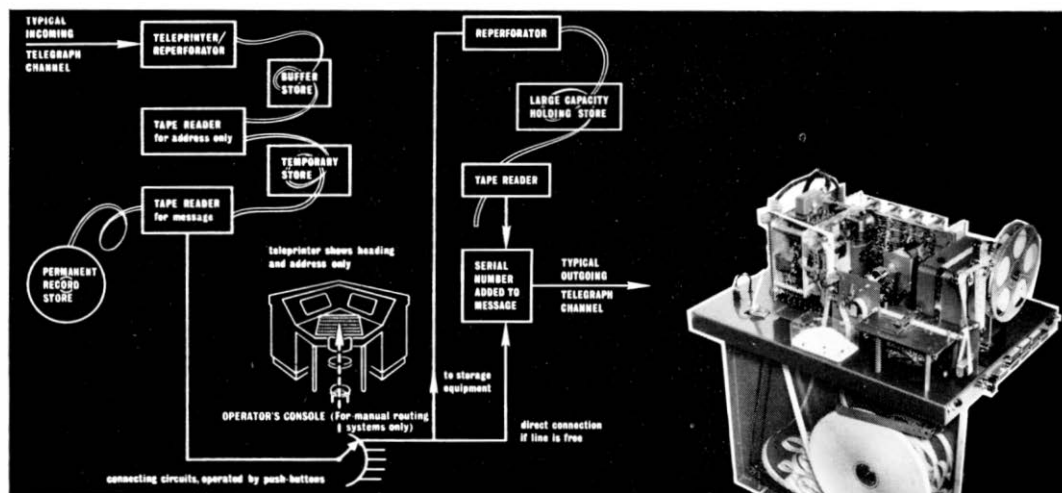

Above: Schematic of AMATI system

Outgoing storage unit



Write, phone or Telex

**Standard Telephones and Cables Limited**

TELEPHONE SWITCHING DIVISION  
OAKLEIGH ROAD · NEW SOUTHGATE · LONDON · N.11  
Telephone ENTerprise 1234 · Telex 21612

# It started in 1890...

... since then, Connollys have continuously supplied telephone cables to the British Post Office—thus contributing to the efficient operation of the public telephone service in this country.

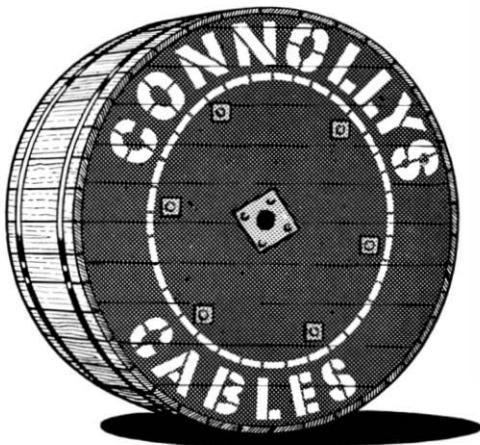

Connollys have also played a prominent part in supplying telecommunication cables for service in most countries overseas.

## CONNOLLYS

**CONNOLLYS (BLACKLEY) LIMITED**

Cable Division, Blackley, Manchester 9. Tel.: Cheetham Hill 1801

dm CL 57

## Combined Tape and Edge Card Reader

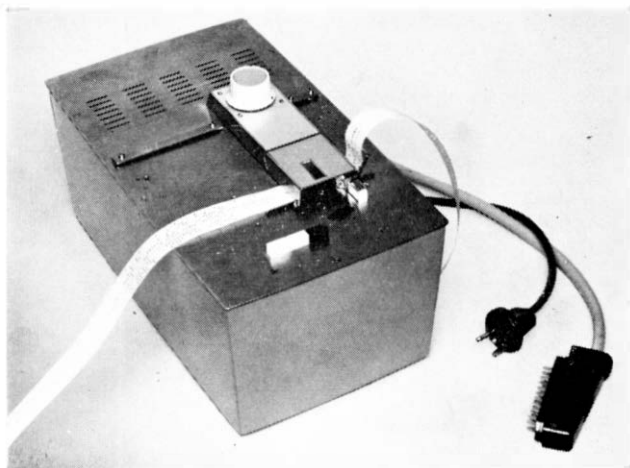

### MODEL 23

5, 6, 7, 8 unit reading of tape and edge card.

Tight tape, tape out, tape latch alarms.

Unlimited manual forward and back-spacing of tape and card.

Free standing or flush mounting in a desk unit.

Signal Contacts made for 95% of each reading cycle.

**G.N.T.**

## GREAT NORTHERN TELEGRAPH WORKS

DIVISION OF THE GREAT NORTHERN TELEGRAPH CO. LTD.

Sydhavns Plads 4, Copenhagen Sv, Denmark - London Office: 5, St Helen's Place, London, E.C.3. Tel. LONDON Wall 4567

# AS MODERN AS TOMORROW

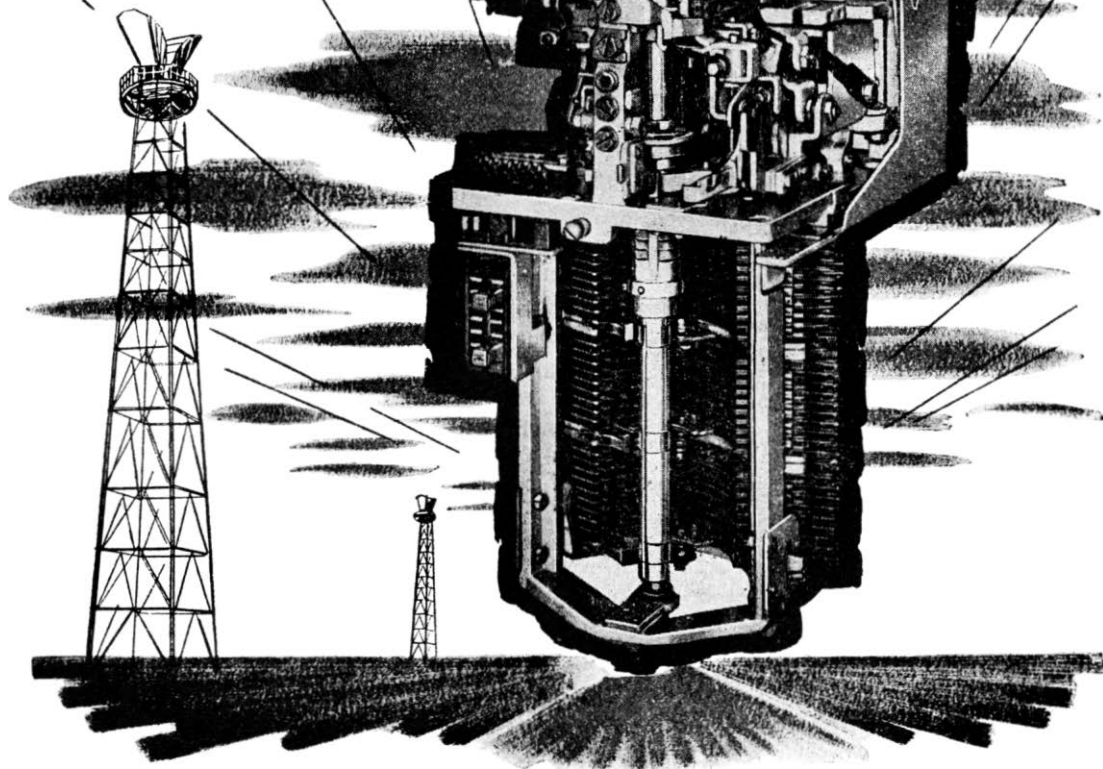

## Telephone Exchanges

The SE50 selector is the most highly developed switch for modern telephone exchanges. Continuous development by G.E.C. engineers using modern materials, techniques and components has resulted in the production of efficient units for tomorrow's telephone networks.

G.E.C. Telephone Exchange Systems are complete, compatible, comprehensive, fully flexible, reliable and simple to service... 'as modern as tomorrow', thanks to constant research and development.

*The majority of the world's telephone exchanges use step-by-step systems.*

Exchange Division

**G.E.C. (TELECOMMUNICATIONS) LTD**

TELEPHONE WORKS · COVENTRY · ENGLAND  
Works at Coventry and Middlesbrough

Smec's 132

*All enquiries for advertisement space  
in this journal should be addressed to  
the sole Advertisement Contractors:—  
SAWELL & SONS Ltd.  
4, Ludgate Circus, London, E.C.4  
(Fleet St. 4353)*