

# The Post Office Electrical Engineers' Journal

---

VOL 69 PART 2 JULY 1976



# THE POST OFFICE ELECTRICAL ENGINEERS' JOURNAL

VOL 69 PART 2 JULY 1976

## Contents

<b>Editorial</b>	67
<b>TXE4 Electronic Exchange System Part 2—Design of Switching and Control Equipment</b> J. L. Phillips and M. T. Rowe	68
<b>The Millimetric Waveguide System: The Design, Production and Installation of the Waveguide</b> W. K. Ritchie and C. E. Rowlands	79
<b>The Experimental Changes of Practice Committees: ECOPCs 2 and 3</b> F. A. Horne, R. E. G. Back, E. Croft, K. Davey and R. E. S. Collett	87
<b>Multiplexing for a Digital Main Network</b> E. R. Brigham, M. J. Snaith and D. M. Wilcox	93
<b>The Thames Valley Radiopaging Trial</b> N. W. Brown and D. Willetts	103
<b>The Protection of Operational Buildings against Gas Entry</b> R. H. Adams and R. Tharby	110
<b>Amplifiers for Local-Line Wideband Distribution Systems</b> B. Hailes and D. P. Nicholls	116
<b>Experimental Packet-Switched Service: The Customers and their Packet Terminals</b> M. J. Burgess and J. A. Lockwood	122
<b>Regional Notes</b>	127
<b>Associate Section Notes</b>	130
<b>The Associate Section National Committee Report</b>	131
<b>Institution of Post Office Electrical Engineers</b>	132
<b>Notes and Comments</b>	134
<b>Post Office Press Notices</b>	135
<b>Book Reviews</b>	78, 92, 109, 121

Published in April, July, October and January by *The Post Office Electrical Engineers' Journal*,  
2-12 Gresham Street, London EC2V 7AG.

Price: 35p (60p including postage and packaging). Orders by post only.

Annual subscription (including postage and packaging): home and overseas £2·40.  
(Canada and the USA \$6·00.)

Price to British Post Office staff: 27p.

# Plessey Pulse Code Modulation Systems

Plessey Telecommunications has been designing and manufacturing the most advanced telephone and telegraph equipment for nearly 70 years. Today Plessey supplies telecommunication systems and equipment to its customers throughout the world from more than 250 establishments – manufacturing plants, service depots and sales offices – around the globe. Plessey research and development, manufacturing capability and product support services cover the whole field of modern telecommunications.

## CD30A PCM gives quality and quantity

Plessey PCM equipment has been increasing traffic capacity in the junction network for many years. This wide experience has been used in the design of a new 30-channel system which provides telephone administrations with an economic and highly flexible means of coping with demands for increased capacity on national and international networks.

A Plessey PCM link is fully compatible with any exchange type and complies fully with CCITT and CEPT recommendations.

Being of modular construction the system can be easily and economically extended when more traffic capacity is needed. In fact, Plessey PCM links can increase the capacity of existing cables by ten times!

The speech quality is of a high order. A PCM link provides excellent transmission performance – independent of route length. And noise levels are considerably improved, too.

The CD30A PCM System employs the most advanced microcircuit techniques and makes extensive use of integrated circuits. The versatile mechanical design

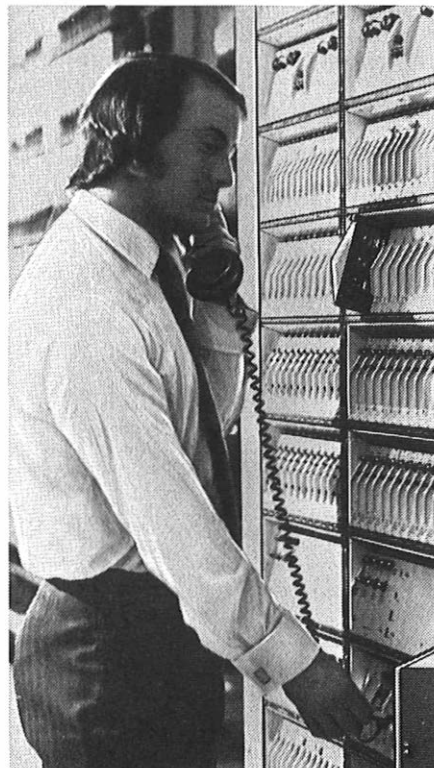

facilitates the rapid transfer of equipment from one route to another when unexpected changes in traffic occur.

The system is capable of application to almost any signalling system in use anywhere in the world, by using signalling units either selected from a standard range or designed to meet particular requirements. Already 18 types of signalling units are in production and the range is continually expanding.

A full range of line equipment is available which includes: terminal regenerators, power feed equipment and intermediate, both way, regenerators. Ancillary equipment includes repeater housings, loading coils, supervisory testing filters, engineering order wire systems and soon.

Plessey engineers will be pleased to advise on the use of existing cables and, when required, to plan and install PCM systems. If you would like further technical information on PCM equipment or an in-depth discussion with one of the Technical Sales Engineers, simply contact Plessey.

 **PLESSEY**

**One of the world's great telephone enterprises**

Plessey Telecommunications Limited, Edge Lane, Liverpool, England L7 9NW. Telephone: Liverpool, 228 4830 Telex: 62267

# BROADBAND RADIO LINKS

# 5.9-7.1 GHz 960 or 1800 channel

## A NEW RANGE FROM GEC

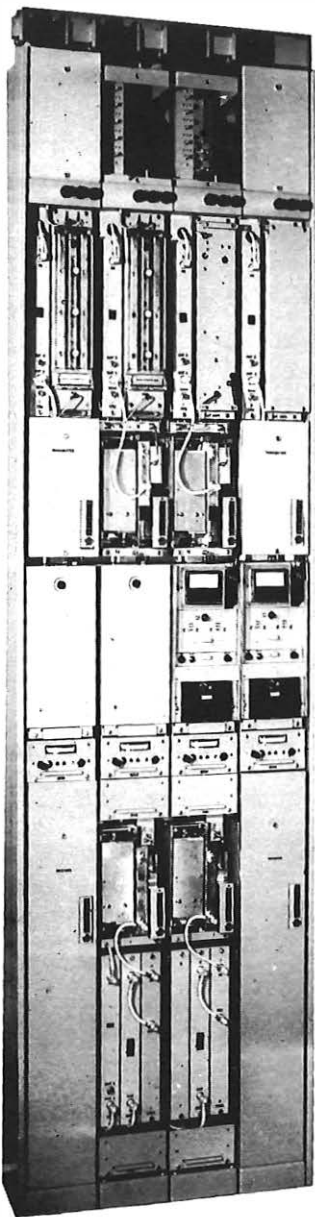

Four 6.8 GHz equipment racks.  
Left to right:  
1 watt, 960 channel rack, covers on.  
1 watt, " " " " off.  
10 watt, 1800 " " " " off.  
10 watt, " " " " on.

- \* Advanced MIC technology.
- \* Modular construction—plug-in interchangeable units.
- \* Interchangeable modules for transmitter output amplifier. IMPATT diode for 1 watt OR long-life packaged TWT for up to 10 watts—with associated power units.
- \* Optimum commonality of other modules throughout the range.
- \* Direct modulation capability.
- \* Minimal frequency-conscious modules.
- \* Flexibility of system design—choice of frequency and transmitter output power within system configuration using the same basic equipment.
- \* Interchangeability without compensating adjustments.
- \* Reduced spare-unit requirements.
- \* Simplified maintenance routines.
- \* Ready expansion above 960 channels with interchangeable modules.



MICROWAVE AND LINE TRANSMISSION · MULTIPLEX · V.F. TELEGRAPHY  
DATA MODEMS · TELEPHONE SWITCHING SYSTEMS · PRIVATE  
TELEPHONE SYSTEMS · TELEPHONES · TOTAL SYSTEMS CAPABILITY

GEC TELECOMMUNICATIONS LIMITED of Coventry, England.  
A Management Company of The General Electric Co. Ltd. of England.

# GEC DIGITAL TRANSMISSION SYSTEMS

FOR LOCAL JUNCTIONS AND TRUNK ROUTES

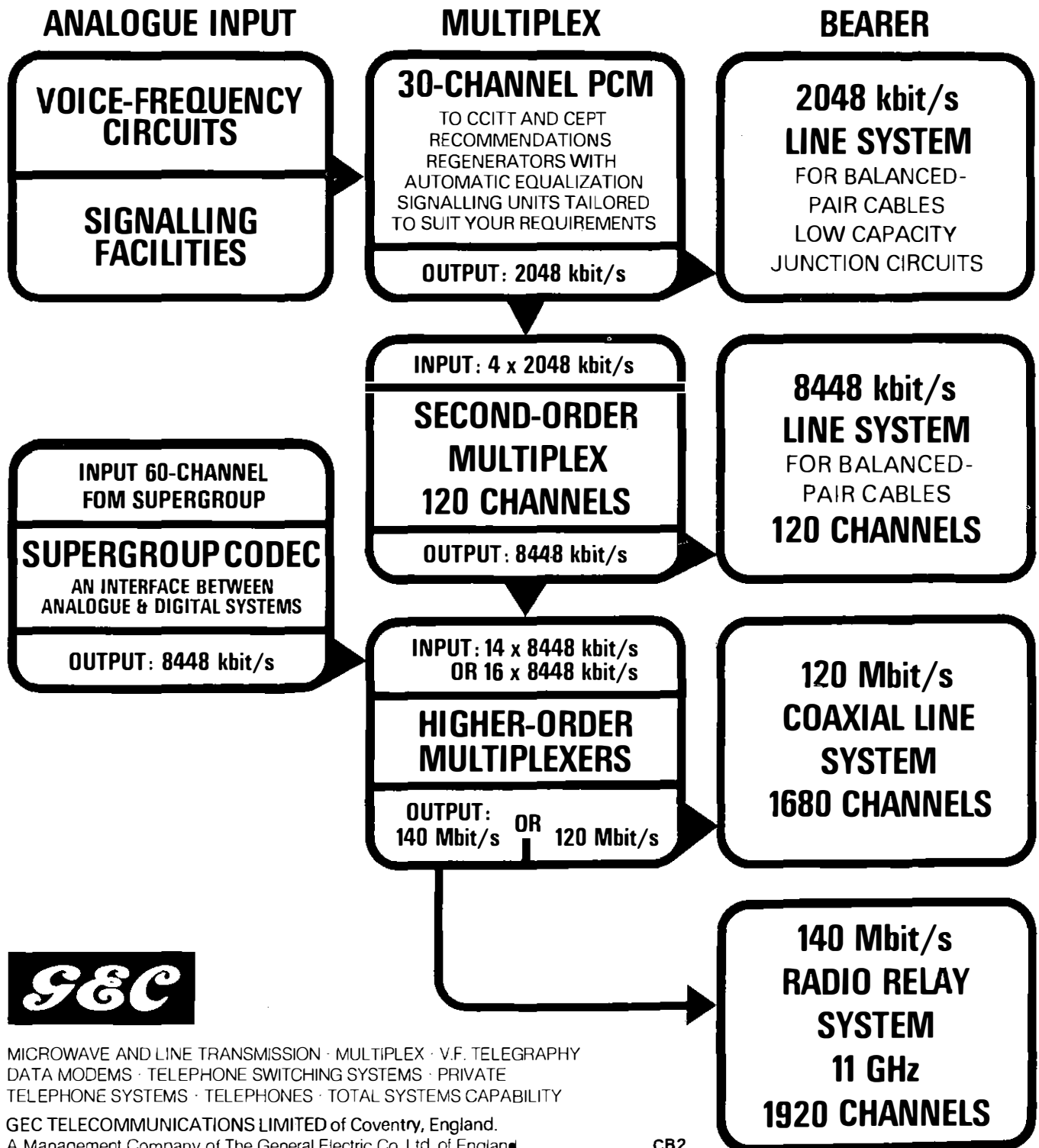

MICROWAVE AND LINE TRANSMISSION · MULTIPLEX · V.F. TELEGRAPHY  
DATA MODEMS · TELEPHONE SWITCHING SYSTEMS · PRIVATE  
TELEPHONE SYSTEMS · TELEPHONES · TOTAL SYSTEMS CAPABILITY

GEC TELECOMMUNICATIONS LIMITED of Coventry, England.  
A Management Company of The General Electric Co. Ltd. of England.

CB2

# Plug in Adaptability with the Record 100 S·A·R & SERVEX Recorders

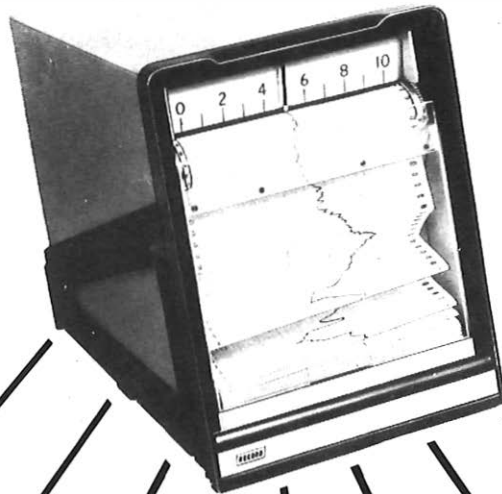

## SIGNAL CONDITIONING MODULES

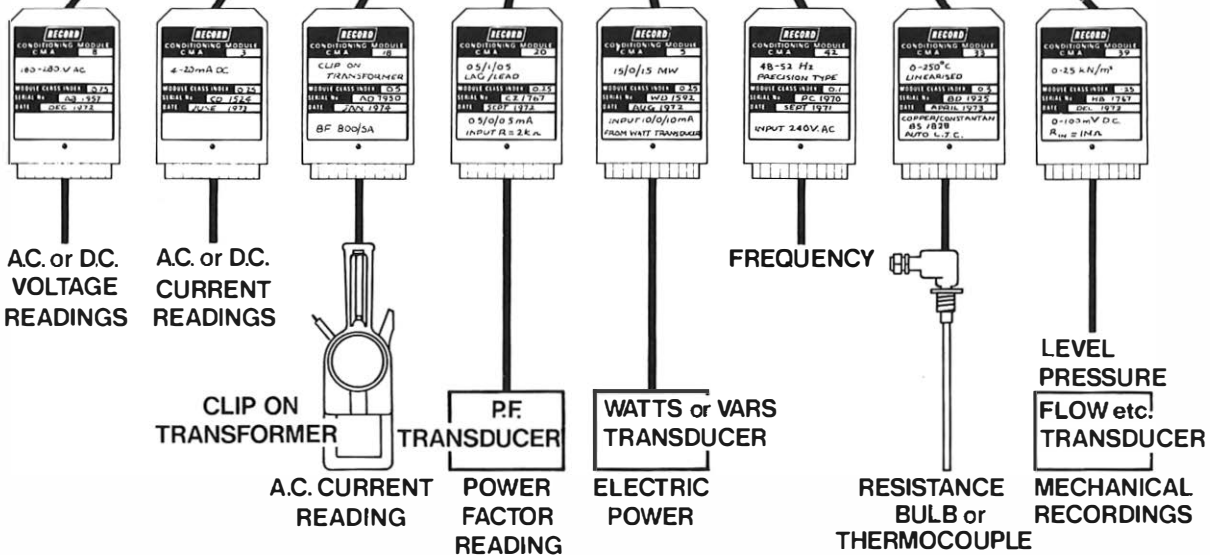

**The Record Electrical Company Limited**  
 P.O. Box No. 19 ALTRINCHAM, CHESHIRE, WA14 5DB  
 Telephone 061-928 6211 Telex 66 7212  
 Telegrams & Cables, Cirscale, Altrincham.





**Mullard is a leading supplier of approved electronic components to the Post Office**



**Mullard**

Mullard Limited, Mullard House,  
Torrington Place, London WC1E 7HD

**Quality Quantity Quickly!**



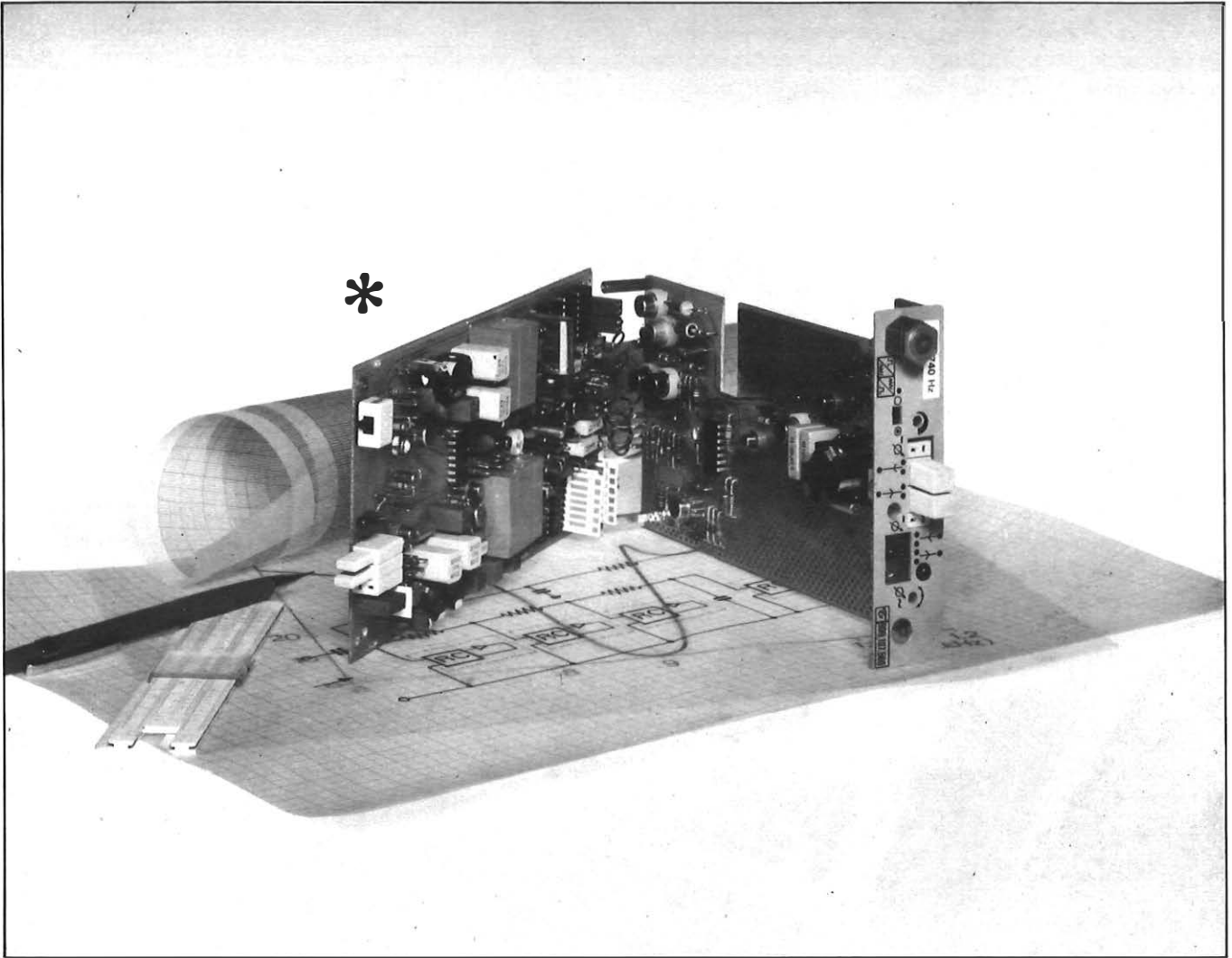

# TG48

## new generation voice frequency FSK multiplex equipment

### Reduced size

Two complete 24-channel systems in a slim rack of dimensions 2600 H x 120 W x 225 D mm

### Extensive use of advanced technologies

Digital frequency modulator and discriminator with complementary MOS integrated circuits - Active RC filters with Tantalum thin-film and beam-lead operational amplifiers

### Low power consumption

32 W per 24-channel system, with typical 1 kohm/±20 mA local circuit

### Simplified maintenance and reduced spare parts

Invariant channel units at equal modulation rate, except for a replaceable crystal for line frequency allocation of the channel

### Excellent frequency stability with temperature and time

Line frequencies within ±0.1 Hz over the 0-50°C temperature range

Modulation rates of 50-100-200 bauds with performance according to, or better than, CCITT recommendations

\* FSK voice frequency channel developed by Telettra's FDM Laboratories.



# The Post Office Electrical Engineers' Journal

---

## BOARD OF EDITORS

J. F. P. Thomas, B.SC., C.ENG., M.I.E.E., Chairman  
E. W. Ayers, B.SC.(ENG.), C.ENG., F.I.E.E.  
A. J. Barker, C.ENG., F.I.E.E.  
A. J. Barnard, C.ENG., M.I.E.E.  
C. E. Clinch, B.SC.(ENG.), C.ENG., F.I.MECH.E., F.I.E.E., F.S.S.  
J. Martin, B.SC.(ENG.), C.ENG., M.I.E.E.  
A. Ness, C.ENG., M.I.E.E.

## Managing Editor

D. Millington, C.ENG., M.I.E.E.

## Assistant Editor

B. Stagg

## Secretary-Treasurer

B. Farr

## Advertisement Manager

R. G. Rothery

## EDITORIAL

Many readers of the *Journal* have expressed an interest in the origin of the Seal of the Institution of Post Office Electrical Engineers which has appeared on the front cover of the *Journal* since the April 1958 issue.

The basic design originates from a competition, organized by Council soon after the formal inauguration of the Institution on 6 June 1906, for the design of an Institution Medal, 4 of which were to be offered as awards for the best papers read to meetings of Local Centres. The winning design was produced in 1907 by an Institution member, Mr. O. P. Moller of the Engineer-in-Chief's office, who received the prize offered by Council; shortly afterwards, Mr. Moller also won the first prize for the winning design in a competition to select the design of the front cover of the first issue of this *Journal*, published in April 1908.

The basic design of the Institution Medal has remained unchanged since 1907 and, from 1923, has been used for the Seal of the Institution, embossed on Institution Certificates. More recently, the form was modified slightly to make it suitable for printing on Institution documents, and this design has been used on the front cover of the *Journal* for the last 18 years.

The first TXE4 electronic exchange was successfully brought into public service at Rectory in the Birmingham Telephone Area on 28 February 1976 (see Midlands Regional Note, p. 128 of this issue). This marked a positive step forward in British Post Office plans for further improving the quality of the automatic telephone service in the UK by the progressive replacement of Strowger electromechanical equipment by electronic systems. This issue of the *Journal* contains a detailed description of the design of the TXE4 switching and control equipment.

# TXE4 Electronic Exchange System

## Part 2—Design of Switching and Control Equipment

J. L. PHILLIPS, C.ENG., M.I.E.E., and M. T. ROWE, B.SC.†

UDC 621.395.345:621.316.54:621.395.65

*This second part of a 3-part article expands on the outline description of the TXE4 electronic exchange system given in Part 1. The method of operation of the more important parts of the TXE4 switching area, speech-path control equipment, cyclic stores, and main control units are described.*

### INTRODUCTION

This is the second part of a 3-part article marking the opening of the first TXE4 electronic exchange, in February 1976, in Birmingham. The first part<sup>1</sup> gave a general introduction to the TXE4 electronic exchange system by outlining the design philosophy adopted, describing the modular design concept

used, and demonstrating the way that facilities are provided. This article goes into the design (completed jointly with Standard Telephones and Cables Ltd.) and operation of the major parts of a TXE4 exchange in more detail. Although a complete description of the entire TXE4 system is beyond the scope of this article, it is hoped that sufficient is included to convey an appreciation of the problems overcome during development, to achieve the basic system concepts fundamental to the TXE4 exchange system.

† Telecommunications Development Department, Telecommunications Headquarters

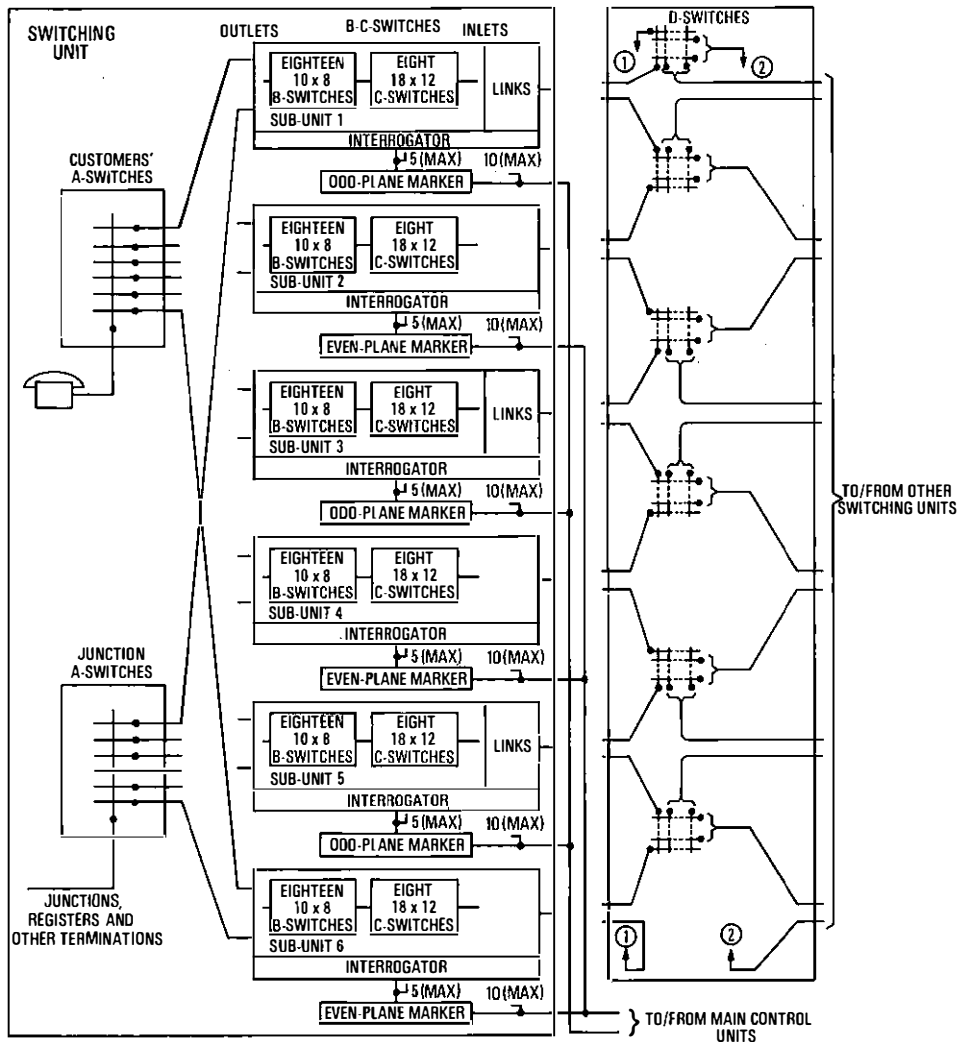

Fig. 1—Six-plane TXE4 unit showing B-C-switch sub-units, interrogators, and markers

## SWITCHING AREA

The TXE4 switching area consists of a general-purpose switch network having 4 stages of reed-relay matrices, designated *A*, *B*, *C* and *D*, controlled by wired-logic markers and interrogators. The expression *general-purpose* means that, in the TXE4 system, all customer and service terminations are connected to, and switched by, a single switching network. Ease of exchange extension and security of service in the presence of faults, respectively, require that the switching area is divided into a number of identical units (further divided into sub-units), and that the controls of these sub-units are independent one from another. The requirement for simplicity of design is achieved by connecting all circuits and terminations to the *A*-stage of the switch network, so that all paths interconnecting pairs of terminations are made up from a pair of half-paths containing 3 and 4 reed-relay switching stages. Interconnexion operations can thus be standard for all types of path. These aspects of the TXE4 design were introduced in Part 1, and are discussed in greater detail in this part.

## SWITCH MATRIX INTERCONNECTION AND TRUNKING

### Units, Sub-Units and Planes

The basic building-brick of the TXE4 switching area is a switching unit (see Fig. 1). Each unit is divided into either 6 or 8 identical B-C-switch sub-units. Generally, a unit containing 6 sub-units can carry a customer's bothway traffic loading of about 170 erlangs, while a unit containing 8 sub-units can carry about 230 erlangs. The actual traffic capacity in any given case can be determined only by considering a large number of factors. All units in any one TXE4 exchange must have the same number of sub-units, there being no provision to change this number during the life of an exchange. The sub-units in a unit are numbered 1-6, or 1-8, as the case may be. All like-numbered sub-units in the exchange are grouped to form a plane. Each of the 6 or 8 planes so formed extends across all units.

The control of connexions in the switch network is performed by markers and interrogators. These are segregated into planes and directly associated with sub-units to ensure that, if a fault occurs, the effect is limited. Traffic is thereafter concentrated on the remaining sub-units. Each customer's line or other termination has one connexion to each plane; that is, there is one connexion to each sub-unit in the unit concerned. Hence, the effect of a fault in the switching area is limited to a reduction in the grade of service, with no termination entirely losing service.

### B-C-Switch Sub-Unit Trunking

The trunking of the B-C-switch sub-unit is shown in Fig. 2, which depicts a fully-interconnected array of 18 B-switches and 8 C-switches. The TXE4 switch network carries traffic in both directions, but, by convention, the side of a reed-relay matrix nearer to the customer's line or other termination is called the *outlet*, while the side nearer to the link circuit is the *inlet*. Each C-switch has 18 outlets (each trunked to the correspondingly-numbered B-switch) and 12 inlets; each B-switch has 8 inlets (each trunked to the correspondingly-numbered C-switch) and 10 outlets. Thus, the B-C-switch sub-unit provides 96 inlets and 180 outlets. Fig. 3 shows a TXE4 B-switch plug-in unit, which incorporates 2 separate  $10 \times 8$  B-switch matrices.

These dimensions result from extensive study, and are a compromise between a module small enough to allow growth in economic steps, and large enough to ensure that the largest exchange will not require an unduly complex arrangement of D-switches. The dimensions also ensure that efficient use is made of the space available on the TXE4 equipment practice.

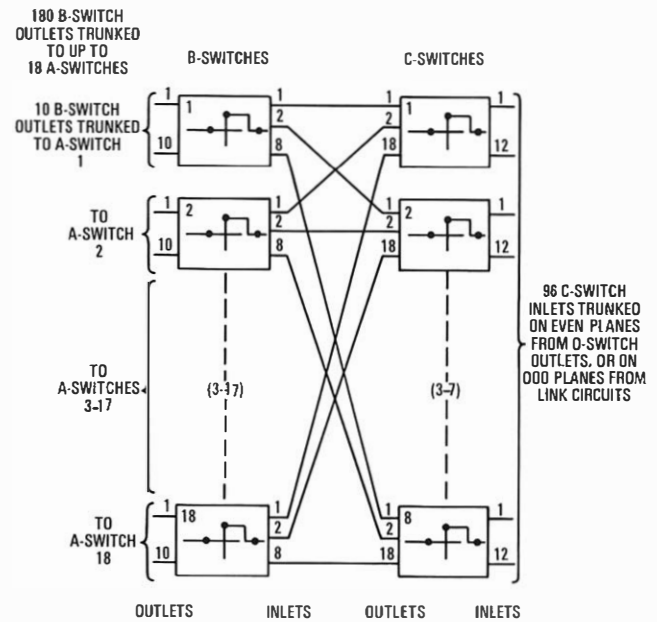

FIG. 2—TXE4 B-C-switch sub-unit trunking

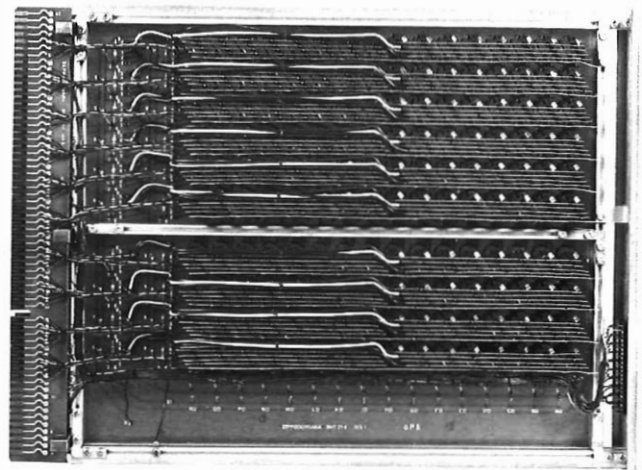

FIG. 3—TXE4 B-switch plug-in unit

The 96 C-switch inlets from each even-numbered sub-unit are connected directly to D-switch outlets, and those from each odd-numbered sub-unit are connected to link circuits and thence to D-switch inlets. TXE4 D-switches are described later; link circuits were described in Part 1. The 180 B-switch outlets from each sub-unit are connected to up to 18 A-switches, these being of 2 types: customers' A-switches and junction A-switches. In the TXE4 system, connexions between switch stages are called *trunks*.

### Customers' A-Switch

The customers' terminations are connected by line circuits to customers' A-switches. Since the B-C-switch sub-units are of standard design and all the B-switches are connected identically, the traffic capacity of each B-switch outlet is the same. One function of the customers' A-switch is to match the wide variation in customers' calling rates to the fixed B-switch traffic capacity. This is achieved by using a variable-concentration A-switch. Up to 12 of the maximum 18 A-switches

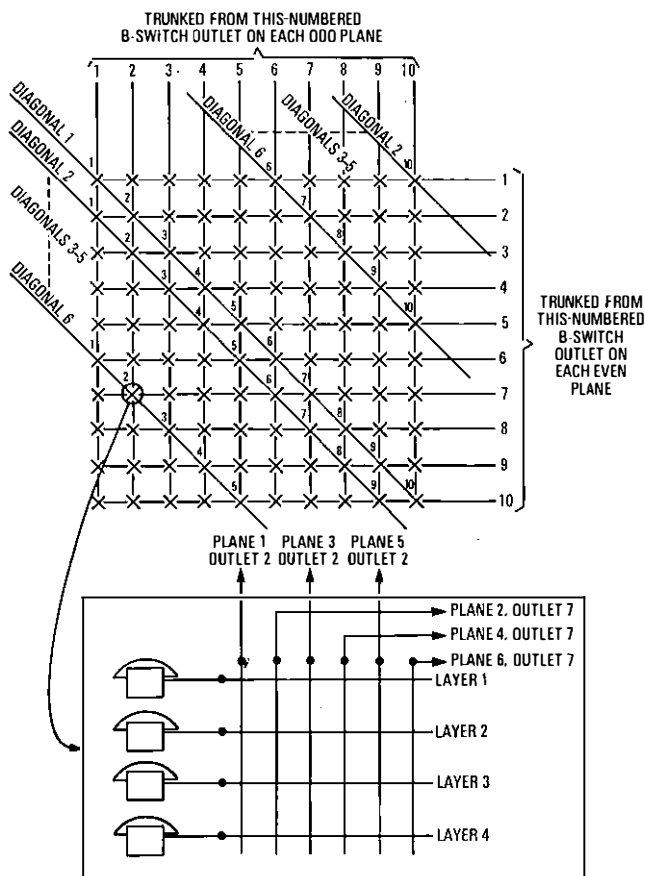

FIG. 4—Customers' A-switch design showing access from B-switches to any of 100 lines in each layer of the switch

connected to each sub-unit can be customers' A-switches. The different traffic characteristics of junctions and other circuits are catered for by using junction A-switches, the design of which is described later.

A maximum of 400 customers' lines can be connected to each customers' A-switch. The basic requirements for this switch are

- (a) to be able to match a wide range of customers' calling rates,
- (b) to achieve security by connecting every customer to every one of the 6 (or 8) planes in the exchange, and
- (c) to minimize blocking by ensuring that, as far as possible, different customers have access to different selections of A-B trunks.

These requirements are met by first splitting the 400 (maximum) lines into 100 groups of 4. Within each group, the 4 lines have identical access into the 6 (or 8) planes, one trunk to each plane, and their A-switches are physically realized as a  $4 \times 6$  (or  $4 \times 8$ ) matrix. The 4 lines are regarded as being one on each of 4 layers of the A-switch, and Fig. 4 shows the way in which these layers are arranged. Within a layer, each of the 100 lines has a different pattern of connexion to the A-B trunks. It can be seen that each of the 10 lines on diagonal No. 1 is connected to the same-numbered B-switch outlet on both odd-numbered and even-numbered planes. On diagonal No. 2, each of the 10 lines is connected on odd-planes to B-switch outlet  $B$ , and on even planes, to B-switch outlet  $B + 1$ . This pattern recurs, so that, in general, the 10 lines on diagonal  $K$  are connected on odd-planes to B-switch outlet  $B$ , and on even planes, to B-switch outlet  $B + K - 1$ . A fully-equipped customers' A-switch is encountered only at average customer calling rates of about 0.02 erlangs. To

match high calling rates up to 0.35 erlangs, no customer connexions are made to one or more of the diagonals; the number of diagonals left unconnected increases as the calling rate increases.

The method of depicting one layer of the TXE4 customers' A-switch used in Fig. 4 enables the pattern of interconnexion and the derivation of the term *diagonal* to be clearly seen. Each complete customers' A-switch can be visualized as 4 such layers stacked together.

### Junction A-Switch

Up to 12 of the 18 B-switches in any sub-unit can be allocated to serve junction A-switches. The junction A-switches are used to connect junction relay-sets, registers and other miscellaneous circuits. In effect, only diagonal No. 1 is provided but this may have up to 6 layers (or up to 8 in an 8-plane exchange). Thus, up to 60 (or 80) terminations can be accommodated on each junction A-switch. Provision is made on 4 of the layers for the junctions to be controlled by the supervisory processing units. This control is described later.

### D-Switches

D-switches interconnect all of the switching units in the exchange by providing, in conjunction with link circuits, connexions between adjacent planes. Each B-C-switch sub-unit has 96 C-switch inlets. Each even-plane C-switch inlet is trunked from a D-switch outlet. Other outlets of this D-switch are trunked to corresponding C-switch inlets on each other sub-unit on the same plane. Thus, for each even-numbered plane, there are 96 D-switches, regardless of how many switching units there are. However, the size of these 96 D-switches increases according to the number of switching units in the exchange. The corresponding C-switch inlets on odd-numbered planes are connected to link circuits and thence to D-switch inlets. The trunking is arranged so that odd-numbered C-switch inlets on even-numbered planes are trunked from D-switch outlets giving connexion to the adjacent higher-numbered plane, whereas even-numbered C-switch inlets on even-numbered planes are trunked from D-switches giving connexion to the adjacent lower-numbered plane. This is shown in Fig. 5, which indicates how paths can be connected between pairs of adjacent planes.

Since a TXE4 exchange is normally extended by the addition of new switching units, each D-switch must be able to grow in size, so that it is always a  $U \times U$  matrix when there are  $U$  switching units.

Rearrangement of equipment and cabling is kept to a minimum by providing D-switches in sizes from  $4 \times 4$  upwards in growth steps of 4 or 8. Several different physical arrangements are available to suit alternative exchange growth patterns.

### EQUIPMENT NUMBER

Before describing the method of setting up paths through the switch network, it is necessary to explain the use of equipment numbers in the TXE4 system. The switch trunking described earlier results in one unique path from any D-switch inlet to any A-switch outlet, however large the exchange grows. Every A-switch outlet is allocated a unique 6-digit equipment number, whose individual digits define the particular outlets to be used in switch matrices at the D-, C-, B- and A-stages to reach that A-switch outlet. Since different routes are followed through the customers' A-switches according to whether the connexion happens to be on an odd or even plane, the convention is established that the equipment number represents the path taken through an A-switch on an odd plane.

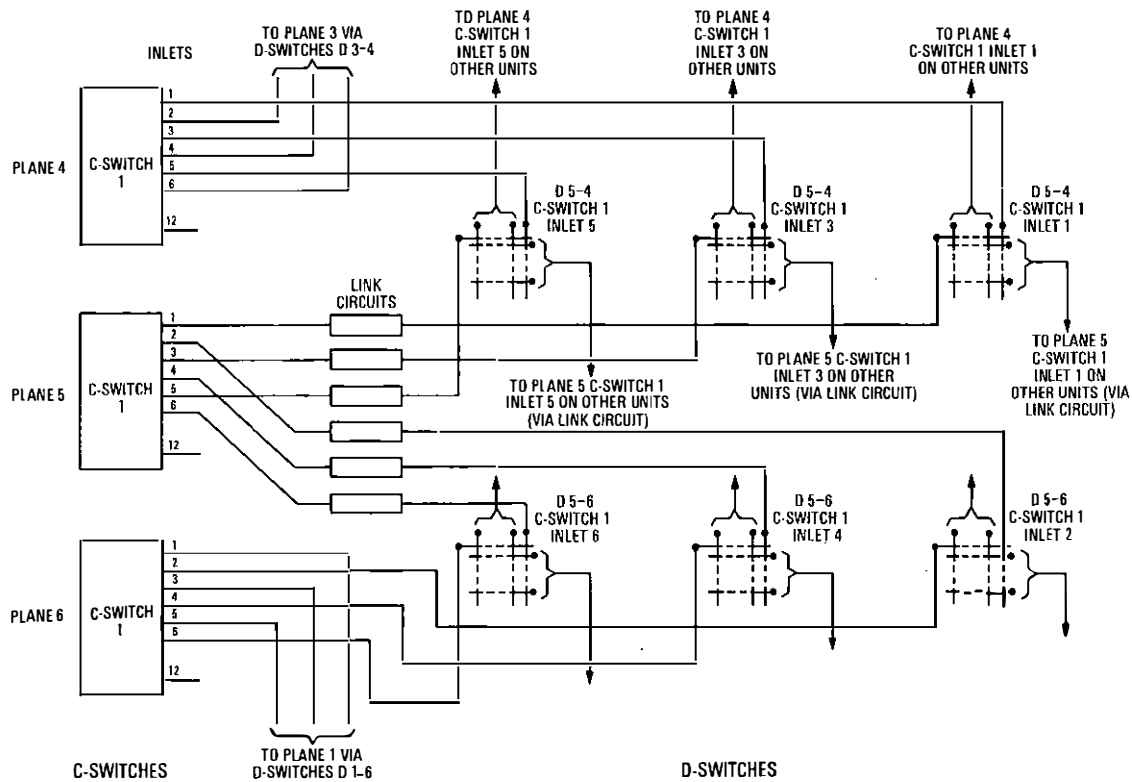

FIG. 5—An example of the interconnexions between C-switches, D-switches and link circuits

The 6 digits of the equipment number are designated *MUCKBL*, each having the following significance.

(a) *M-Digit* (1-out-of-10) The M-digit consists of a 1-out-of-2 and a 1-out-of-5 selection. The 1-out-of-2 selection is combined with the C-digit (see below) to identify one of the 18 outlets of the C-switch. The 1-out-of-5 selection identifies the one of up to 5 sub-units that can be associated with each marker.

(b) *U-Digit* (1-out-of-10) The U-digit identifies the switching units controlled by a particular one of the 10 markers that can be provided on each plane. The M-digit and U-digit combine to identify one of the switching units in the exchange.

(c) *C-Digit* (1-out-of-9) The C-digit, combined with the M-digit as already described, identifies the required outlet at the C-stage; these directly identify the B-switch and A-switch numbers.

(d) *K-Digit* (1-out-of-10) The K-digit identifies the appropriate A-switch diagonal.

(e) *B-Digit* (1-out-of-10) The B-digit identifies the required outlet from the B-switch.

(f) *L-Digit* (1-out-of-8) The L-digit identifies the appropriate layer in the A-switch. For customers' A-switches, values 1-4 are used; for junction A-switches, values 5-8 are used, together with K-digits 1 and 2.

The main control units must establish the equipment number of any calling or called termination, and signal the information to markers to initiate path selection. The equipment number is also used by the supervisory processing units to identify the circuit being processed.

### CONTROL OF SPEECH PATH

Serial trunking is a basic feature of the TXE4 system, and was described in Part 1. Two or more standard 7-crosspoint paths are set up in turn, depending on the facilities required on a call. Each path connects a pair of A-switch terminations

and includes either a bridge-link circuit or a through-link circuit as appropriate. Each path-setting operation follows a standard sequence, which can be considered as 3 successive processes:

(a) interrogation of the switching area to identify free paths capable of interconnecting the required pair of A-switch terminations,

(b) path selection, whenever there is a choice of free paths, and

(c) marking the chosen path and operating the reed-relay crosspoints to establish the call.

### Interrogators

Each connexion through the switches consists of 4 wires: 2 of these form the speech path, one provides the signalling and metering wire (equivalent to a Strowger P-wire), and the fourth provides the holding circuit for the crosspoint relays. Since the first 3 of these can carry a variety of voltages, resulting from signalling, switching or other operations, only the hold wire (H-wire) can be inspected to determine whether a trunk is free or busy. A TXE4 exchange can have a very large switch network, and so a correspondingly large number of trunks must be inspected at each interrogation. Each trunk requires a voltage discrimination circuit. It is not practical to connect all trunk H-wires directly to all main control units, so the discriminating circuits are located with the sub-units served to form an interrogator.

### Markers

A certain amount of storage and control logic must be associated with the interrogators to enable them to function. In addition, a TXE4 exchange can include a large number of interrogators and up to 20 main control units, with information paths linking these 2 groups of equipment. Substantial savings are achieved by centralizing most of the storage and

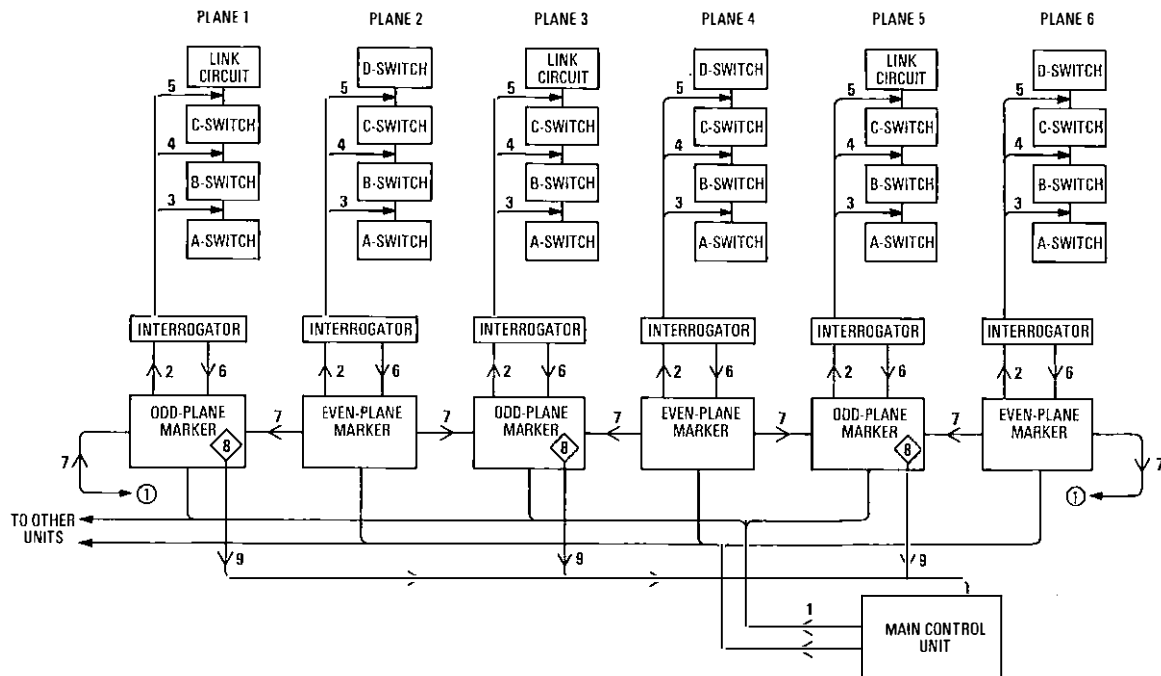

- 1--Main control unit sends equipment numbers to markers
- 2--Markers start interrogators
- 3--Interrogate B-switch outlets
- 4--Interrogate C-switch outlets
- 5--Interrogate C-switch inlets
- 6--Free half-paths signalled to markers
- 7--Even-plane markers pass free half-path information to odd-plane markers
- 8--Odd-plane markers compare half-paths
- 9--Suitable free complete paths signalled to main control unit

FIG. 6—TXE4 speech-path interrogation

control logic away from the interrogators in marker equipment. Each marker is shared by a group of up to 5 interrogators, associated with sub-units all on the same plane. Thus, the design of the information paths between the control and switching equipment is simplified, because communication is required only between up to 20 main control units and up to 10 markers on each plane. Each marker is connected by a further information path to each of the up to 5 interrogators that it controls. The pattern of marker sharing by interrogators must be the same on each plane. Because a TXE4 speech path is always made up of a pair of half-paths on adjacent planes, pairs of markers on adjacent planes use further information paths between them to work together to complete a connexion.

## PATH SETTING-UP SEQUENCE

### Interrogation

The decision to connect a path between a pair of A-switch terminations is made by a main control unit, which must also decide whether the path should include a bridge-link or a through-link circuit. Because the interrogation process, shown in Fig. 6, potentially involves the entire switching area, the function must be on a one-at-a-time basis. Secure arrangements are therefore made to allow main control units to queue, and to be allocated singly to the interrogation facilities. (The security arrangements prevent a faulty main control unit obstructing access from other main control units to the interrogation facilities. This would disable the exchange.) The main control unit designates one of the pair of A-switch terminations on each path as the primary, and the other as the secondary equipment number. The main control unit, when allocated, signals one of these equipment numbers to all odd-plane markers, and the other to all even-plane markers (action 1 in Fig. 6). Additional signals indicate whether a

bridge-link or a through-link circuit is required, which of the equipment numbers is the primary, and the appropriate operating mode to be used later by the markers. It is also possible to indicate to the marker that a previous path in the particular serial trunking sequence is already connected to either or both of the terminations; hence, the known busy condition on the relevant A-B trunks is anticipated and allowed for.

All the markers check the equipment number they receive, to determine whether access can be obtained to the corresponding A-switch outlet through one of the switching sub-units that they control. One marker on each plane responds by sending a *start* signal to the appropriate interrogator. This is followed by signals to indicate the wanted B-switch and C-switch outlets, and the type of link circuit to be used (action 2 in Fig. 6). Interrogation of the relevant B-switch outlet (action 3 in Fig. 6) is, if the outlet is free, followed by a determination of the state of all C-switch outlets leading to the required B-switch (action 4, Fig. 6). For each free C-switch outlet, free C-switch inlets connected to the required type of link circuit are also determined (action 5, Fig. 6). The information thus established is signalled to the marker (action 6, Fig. 6), which, in the case of an even-plane marker, passes the information on to each adjacent odd-plane marker (action 7, Fig. 6). The latter then hold details of all potentially suitable half-paths on their own plane and both the adjacent even planes.

### Path Selection

The odd-plane markers next make a systematic comparison between pairs of free half-paths involving both sides of individual link circuits (action 8, Fig. 6). The sequence of comparison is designed to achieve a definite path-selection strategy. The first free path found is selected, and the path details are temporarily stored in the marker. The process described normally takes place concurrently in one marker

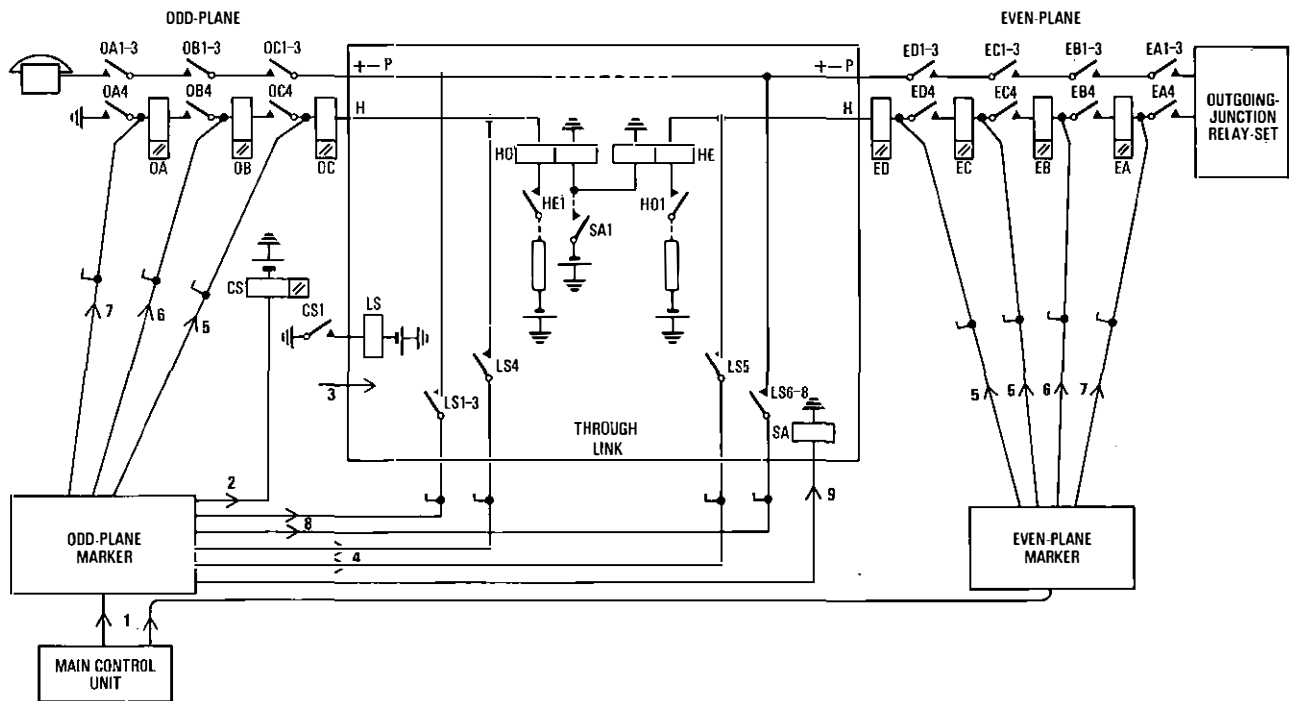

- 1—Initiate marking signal
- 2—Operate C-inlet selection relay (via odd plane)
- 3—Through-link circuit switches access to both sides of path to odd-plane marker
- 4—Apply  $-90\text{ V}$  condition to H-wire
- 5—Mark and switch D-switches and C-switches
- 6—Mark and switch B-switches
- 7—Mark and switch A-switches
- 8—Apply path and P-wire checks as required
- 9—Link seizure and marker release

FIG. 7—TXE4 marking and path-setting sequence

on each odd plane. When each of these markers (3 in 6-plane exchanges, 4 in 8-plane exchanges) detects a suitable free path, it signals to the waiting main control unit to indicate whether the path involves the plane above, the plane below, or both (action 9, Fig. 6). No signal is sent in cases where no free path is available. If none of the markers signals, the main control unit repeats the entire interrogation sequence, but this time, the primary and secondary equipment numbers are sent to the opposite groups of markers. When no path results from this second interrogation, the next action is determined by the main-control-unit programme appropriate to the type of call. Repeat-attempt arrangements will be described in Part 3 of this article.

The main control unit is normally offered paths by several of the markers. The signalling sequence is so arranged that possible paths are signalled in ascending order of C-switch number. The main control unit chooses the first signal received, and this results in the choice of whichever path uses the lowest-numbered C-switch. This selection strategy is used to concentrate calls into the lowest-numbered C-switches. This maximizes the probability that the next (random) request for a connexion between 2 A-switch terminations will also be successful. Traffic capacity is thus maximized. Various aspects of the TXE4 path-selection strategy have been studied by computer simulation, and this work has been described in this *Journal*.<sup>2</sup> The main control unit makes a random selection if 2 or more markers offer a free path at the same time; that is, through like-numbered C-switches.

When a free path is found by the first half of the interrogation cycle, the interrogation and path-selection sequence takes about  $750\ \mu\text{s}$ ; this becomes  $1.5\ \text{ms}$  when the second half of the interrogation cycle is also required. This speed is needed because a large TXE4 exchange may have to perform about 500 000 interrogation cycles in a busy-hour, with occasional very high peaks of activity.

### Marking

Once a unique path has been chosen through the switch network between the required pair of A-switch terminations, the next step is to operate the required reed-relay crosspoints. This must be done in such a way that no other crosspoint operates, and there is no interference with established calls through the same reed-relay matrices.<sup>3</sup> The marking sequence, shown in Fig. 7, is initiated by the main control unit immediately after a successful interrogation, and is carried out by one odd-plane marker, working in conjunction with an even-plane marker. The main control unit indicates to the particular odd-plane marker whether the connexion is required to the plane above, or below (action 1 in Fig. 7). The odd-plane marker operates a C-inlet selection relay (CS) in the appropriate odd-plane C-switch (action 2, Fig. 7). In consequence, other relays in the link circuit operate to extend the 4 wires of the switch path from both sides of the link circuit into the marker (action 3, Fig. 7). A  $-90\ \text{V}$  potential is connected to the H-wire on each side of the link circuit to mark the D-switch inlet in the even plane, and the C-switch inlet in the odd-plane (action 4, Fig. 7). The 7 crosspoints forming the path are marked and switched in sequence by applying suitable potential to the H-wire at each switch outlet to energize the crosspoint relays (actions 5, 6 and 7, Fig. 7). The relays are then held in series through their own H-wire crosspoint contacts. The 2 half-paths are set up respectively in the sequence C-B-A and D-C-B-A. The sequence takes about 25 ms.

Before the markers release for use on further path-setting sequences, the path set up is checked (action 8, Fig. 7). The markers refer to information stored internally; this indicates which end of the path is the primary equipment number, and the mode of marker operation specified by the main control unit. The marker can then perform path-continuity and busy/free checks on the connexion. This process identifies and

avoids cases where 2 main control units attempt a connexion to the same equipment number within a few milliseconds of each other, and detects faults in the equipment. If a check fails, the connexion is released. A repeat attempt to connect the path is made if the main control unit fails to detect that the path is set up. Where the checks are successful, a *link-seize* signal is sent from the odd-plane marker to connect a controlling relay contact of the link circuit in series with the H-wire of each of the half-paths (action 9, Fig. 7). This holds the crosspoint connexion for the duration of the call, and the markers now release.

The marker checks take about 7 ms, so that the pair of markers involved in any path-setting operation are held in all for about 32 ms. During this time, the markers are not available to take part in a further interrogation operation. Occasionally this results in no path being offered to a main control unit, although one is available through sub-units controlled by the busy markers. The repeat-attempt features in the main-control-unit programme reduce the actual call loss that results to negligible proportions.

### SUPERVISORY CIRCUITS AND SUPERVISORY PROCESSING UNITS

Established calls are connected through supervisory circuits, which provide facilities to ring the called customer, detect the answer, detect clear-down of the calling and called customers, transmit speech, and charge the call. Own-exchange and incoming-junction calls are supervised by bridge-link circuits; outgoing-junction calls are supervised by circuits associated directly with the junction. TXE4 supervisory circuits are served by common processors called *supervisory processing units*. A supervisory processing unit is associated with each odd-plane marker, and receives details of each call, as it is connected, by monitoring the signals on the main-control-unit-marker information paths. The supervisory processing units serving a switching unit, or, in the case of marker sharing, up to 5 switching units, combine their operation to provide security. Each supervisory processing unit processes all the bridge-link circuits connected to the sub-units under its control. Outgoing-junction relay-sets, however, are processed by all supervisory processing units associated with the appropriate switching units, the performance of the supervisory processing units being compared and majority decisions taken. Each supervisory processing unit contains a ferrite store, which holds an indication of the current situation in each supervisory circuit. The store has a capacity of 4096 words each of 12 bit. However, to simplify the addressing technique used, the processing capacity of a supervisory processing unit is limited to 2720 supervisory circuits. The supervisory processing unit scans each supervisory circuit at 156 ms intervals and, at each scan, instructions are issued having regard to the type of supervisory circuit, the type of call, the point reached in the call, and the presence or absence of timing pulses indicating call-charging rates.

The instructions sent by the supervisory processing unit are of short duration, nominally  $2\ \mu\text{s}$ . Consequently, it is necessary to staticize these signals in a logic buffer provided with each supervisory circuit, to facilitate the operation of relays in the supervisory circuit. The staticized signals are erased after a scan period of 156 ms and, if they are required for a longer period, they must be reset.

### CYCLIC STORES

The cyclic stores hold the semi-permanent data that define customers' numbers, and the trunking and routing arrangements at the particular exchange. These data must be altered from time to time; this constrains the physical arrangement of the cyclic store which, therefore, consists of a read-only, Dimond-ring transformer store. In addition, the cyclic stores

include equipment for scanning customers' lines and other circuits on a regular basis to detect, for example, their free or busy state. The racks on which the cyclic stores are mounted also contain the customers' A-switch and line-circuit plug-in units.

### Data-Threading Field

A view of the data-threading field on one cyclic-store rack is shown in Fig. 8. Each field contains 90 Dimond-ring transformer cores, arranged in a  $10 \times 9$  matrix. Connexion tags,



FIG. 8—Cyclic-store data-threading field

providing a range of cyclically-generated pulses, are equipped above and below the field. To put data into the field, a pair of tags is selected, and a single wire, joining the tags, is threaded through one transformer core on each of up to 10 rows. Such a wire forms a single-turn primary winding on each transformer core that has been threaded. When a current pulse passes through the wire, an output is generated by the permanent secondary winding of the core. This output is detected and converted into code form to indicate the decimal digit corresponding to that core.

If the wire represents a customer's line, the data given specify the directory number of the line and the class of service available to it. Up to 4 digits are available to state class of service, and these can indicate, for example, PBX lines, coin-box lines, dial and/or key signalling, and various types of call barring applied to incoming or outgoing calls, or to specific types of call. Provision is made for a second threading-wire for any customer's line if the facilities on the line are more complex. A main control unit can determine the equipment number of any line by observing both the special threading-wires that identify blocks of numbers, and the time in the scanning cycle at which the data for the wanted line are generated by the cyclic store.

A threading-wire is also provided for each junction, register, or other circuit served by the exchange. In these cases, the data can indicate the type of circuit, the identity of the circuit, the junction route connected to the circuit, and any special facilities or signalling arrangements. In all cases, the equipment number is specified by the threading. Translation and call-routing data are specified by one or more pairs of threadings for each of the number codes to which the exchange is required to respond.



The cyclic pulse feeds are such that the data for each customer's line are generated every 156 ms, whereas the data for most other equipment are generated every 36 ms. Exceptionally, data for incoming junctions are generated every 12 ms to facilitate the fast association of register equipment. Translation data are provided at 156 ms intervals. These times are set having regard to the relative numbers of threading-wires in each class in a typical exchange, and to the relative urgency of making any particular data available to main control units.

### Line Scanning

The cyclic store also includes line-scanning equipment. For customers' lines, the equipment includes ferrite-core storage, which retains a record of the stage reached on the particular call. Each customer's line is scanned at the same time as the main cyclic store information is generated; that is, every 156 ms. The instantaneous line conditions are correlated with the ferrite-store data, and logic circuits then determine the state-of-line condition that has to be presented to any main control unit requiring the information.

The ferrite-core store data are then updated in preparation for the next scanning cycle. This state-of-line processing allows a number of facilities to be given without involving a main control unit. For example, when an incoming call to a line is cleared by the calling customer, a 5–10 s delay is given to allow the called customer to clear without generating a new calling condition. This reduces the number of false calling conditions that would otherwise occur. A further facility is the ability to park a faulty or permanently-held line, without holding any common or switching equipment. In the event of a major cable breakdown, this can substantially reduce congestion caused by a large number of false calling conditions.

The line-scanning equipment for circuits other than customers' lines does not include ferrite-core storage, the instantaneous state of each line being presented directly to any main control unit.

### Physical Arrangements

Each rack of cyclic-store equipment provides for up to 480 customers' lines, 84 incoming junctions and 126 circuits of other types. Up to 40 translations can be accommodated. Additionally, any of the 480 customers' line appearances can be converted to hold translation information. Four cyclic-store racks form a cyclic-store set and, from this set, an information path is provided which has connexions to every main control unit. For security, the information path is duplicated, and each provides for the parallel signalling of 10 decimal digits, coded in 2-out-of-5 format, which permits the detection of errors. Nine of the decimal digits are derived from the data-threading field; the tenth is produced by the line-scanning equipment and indicates the state-of-line conditions.

The data broadcast on the information path consist of a sequence of information taken from the customers' line, incoming junction and miscellaneous portions of the cyclic store. Data from the 4 racks are similarly interleaved. An important security feature is that the information path is unidirectional. This prevents the misoperation of the cyclic stores, or mutilation of the data, by a faulty or wrongly-programmed main control unit.

Three such sets of racks form a cyclic-store *tri-set*; up to 7 tri-sets can be provided in each TXE4 exchange. Thus, one limit of the TXE4 system is reached when there are 84 cyclic-store racks, each storing the data for 480 customers' lines.

### Data Search by a Main Control Unit

Whenever a main control unit requires a connexion to be made to a particular termination, one or more searches must

be made in the cyclic-store data to determine, for example, the relevant equipment numbers and the facilities that are available to that termination. The unidirectional broadcasting philosophy allows any number of main control units to search for the same, or different, data simultaneously. Several types of search are required during the processing of a call. The type of search required is selected by the main-control-unit programme, the search being accomplished by a wired-logic section of the main control unit, termed the *comparator*.

The general principle is that any known data are loaded into a store in the comparator, along with a *type-of-search* instruction, under the direction of the main-control-unit programme. The comparator examines the cyclic-store data from all of the tri-sets in the exchange, comparing each entry in turn with the known data. When parity is obtained, all of the data from the cyclic store are transferred to the comparator store, and an indicator flag is set within the main control unit. The store is regularly inspected by the main-control-unit programme, until such time as the flag indicates that the required information is available for use. The options given by the *type-of-search* instruction include advice as to whether

- (a) 156 ms, 36 ms or 12 ms information should be observed,
- (b) special action is necessary to record the cycle time at which the data are found, and to use the information to determine the equipment number of a customer's line, and
- (c) the data to be recorded in the comparator should be that seen at the time of comparison or that read from the cyclic store a predetermined number of pulse-intervals later.

As an example, a search for a free outgoing junction on a predetermined route can be achieved by priming the comparator store with the known route number and the digit indicating free state-of-line. By starting the search at random, the equipment number of a free junction on the required route will, in due course, be read from the cyclic store into the comparator. Alternatively, by starting the search at a specific point in the cycle, a junction route can be searched sequentially, thereby imitating the way in which a Strowger exchange offers traffic to a route. In searches for new calling conditions from customers, registers or junctions, all cyclic stores are observed simultaneously. For this purpose, no initial data is required by the comparators.

## MAIN CONTROL UNITS AND REGISTERS

Main control units are special-purpose register processors. Their most important functions are to determine when calls are to be connected, and to operate the speech-path control equipment to establish the calls. To achieve this, the main control units use programme-control techniques to correlate information received by registers with the data obtained from the cyclic stores.

The number of registers provided in each exchange is determined by the nature of the traffic handled and its intensity. In the TXE4 system, a single design of register can deal with any incoming, outgoing, tandem (transit), or own-exchange call. Registers are designed to accept loop-disconnect (10 pulses/s) signalling, which is expected to predominate in UK local exchanges for the next few years. Special add-on units will be used to enable registers to provide facilities for multi-frequency customer or junction signalling systems. Each register in the exchange is associated with, and controlled by, one of the main control units. Up to 36 registers can be associated with any one main control unit. From 3–20 main control units are provided in each exchange.

The internal design of a main control unit is shown in Fig. 9. The 4 main areas are

- (a) the programme store, which, with associated circuits, is designated the *control translator*,

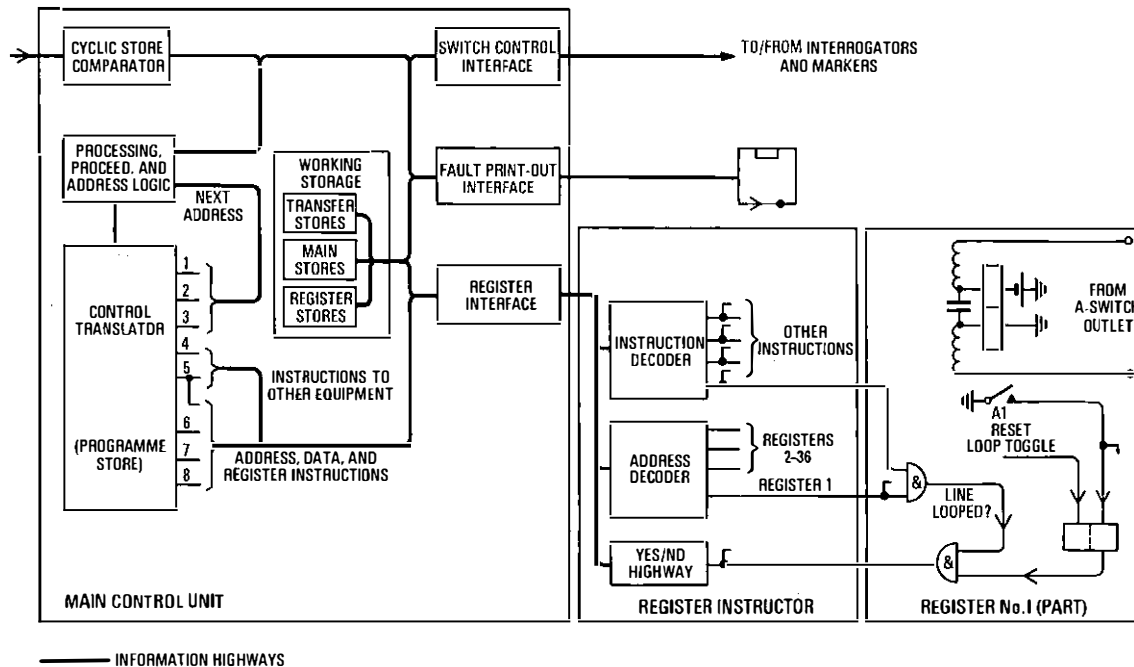

FIG. 9—TXE4 main control unit and register

- (b) the working storage,
- (c) interface equipment terminating the information paths connected to the registers, cyclic stores, markers and interrogators, and the fault-teleprinter equipment, and
- (d) general control, internal-monitoring and decision-making circuits.

### Control Translator

A control translator contains the copy of the stored programme that determines the actions of a main control unit. Storage is effected on a read-only threaded-core store, similar in operating principle to the cyclic store described earlier. The programme is provided on a series of plug-in units, and each programme word is defined by a wire threaded through one of the 10 cores in each of 8 rows. Thus, each programme word has 8 denary digits. A programme word can include a blank in one or more positions. The main-control-unit programme has capacity for up to 5000 words.

The programme store is not cyclically addressed. Instead, each word is selected for read-out by a decision process which inspects the preceding programme step and the status of any relevant signals from interface equipment or from the working stores.

Each step in the programme takes  $12 \mu\text{s}$  to execute and is identified by a letter (A–E), called a *proceed*, plus a 3-digit number. The 8 digits in each word are allocated as follows.

(a) Digits 1–3 define the 3-digit portion of the number of the next programme step to be used. Alternatively, one or more of these digits can be left blank, in which case the missing digits are obtained from elsewhere in the main control unit, according to the instructions given by later digits in the programme word.

(b) Digit 4, or digits 4 and 5, define an instruction. Examples of instructions are *read from store*, *write to store*, *signal to register*, *read cyclic-store comparator*, or *send digits 5–8 (or 6–8) to the working store*. Each of these instructions either defines the proceed (A–E) of the next step, or asks a question. In the latter case, decision logic selects the proceed according to the answer to the question. This facility allows branching in the main-control-unit programme.

(c) Digits 5–8, or 6–8, may be used to generate fixed data to be inserted into the working store for later processing. Alternatively, the digits may define a particular location in the working store, or a particular signal to be sent to a register, a marker, or to other equipment external to the main control unit.

### Main-Control-Unit Programme

A full description of the organization of the main-control-unit programme, and the programming techniques used, is outside the scope of this article. It is, however, interesting to note the method by which routine serial processing of registers is combined with the more complex processing required at various stages of a call. The main-control-unit programme can be divided into 4 areas: the start, executive, register and main programmes. These are shown in Fig. 10.

The start programme is used only after a major failure, to ensure that all stores are clear and that normal operation commences in a systematic way. The principal function of the executive programme is to share the available time of the main control unit such that individual registers are processed at regular intervals. For loop-disconnect registers, the incoming signals are processed every 25 ms. Logic within the register ensures that pulses of shorter duration are correctly received and interpreted. Outgoing pulsing requires processing alternately at  $33\frac{1}{3}$  ms and  $66\frac{2}{3}$  ms intervals, to ensure that the transmitted pulses are maintained within the required limits. This regular processing is accomplished by the register programme, which also assembles completely received digits and stores them in the appropriate register ferrite-store.

At suitable stages in a call, the register requires more complex processing (for example, to establish the routing of the call) and this is the function of the main programme. Each register circuit is connected to a cyclic-store scanner so that it can indicate a state of line. When required, the register programme instructs the register to activate its scan-lead, thus indicating a calling condition to the cyclic store. When the main control unit is free to accept further tasks, it searches the cyclic-store data for a calling state-of-line condition from a customer's termination, incoming junction or associated

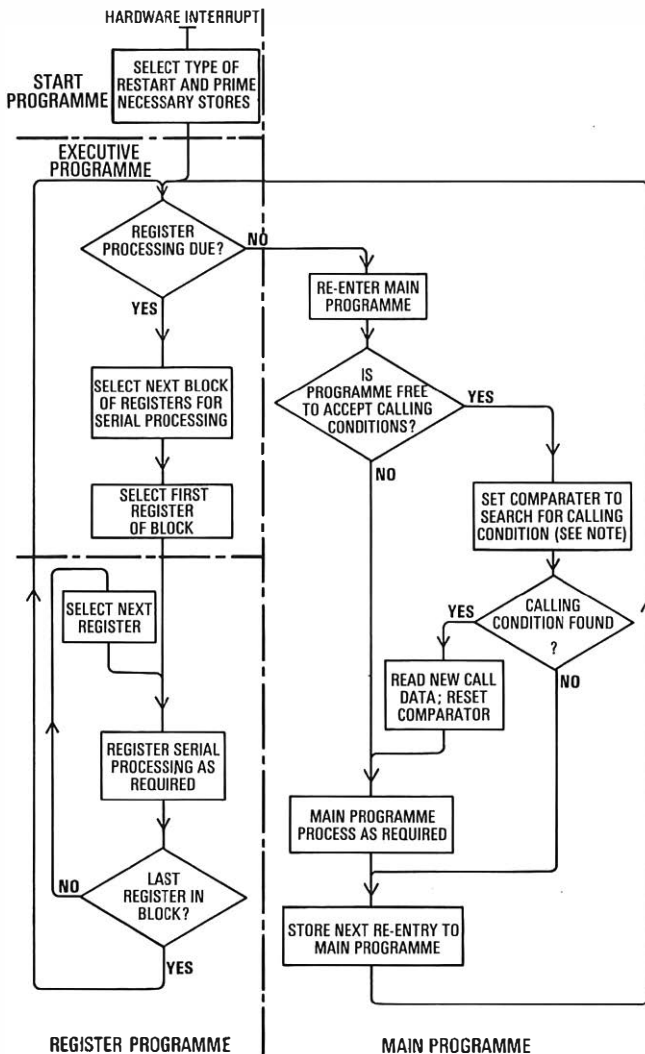

Note—Comparator searches for own registers and, when this main control unit is allotted, for calling customer or junction. Search continues during serial processing and until comparator is reset.

FIG. 10—TXE4 main-control-unit programme

register. In the latter case, the main control unit recognizes that main-programme processing of that particular register is now required. The process described allows registers to queue for the main programme, and ensures that the main control unit continues to operate correctly during periods of abnormal demand for processing.

The main programme includes the facilities that enable the main control unit to use the comparator for finding particular information in the cyclic stores. Because some of the cyclic-store information appears only at 156 ms intervals, corresponding parts of the main programme may require several hundred milliseconds to execute. During this time, the register processing must remain on schedule. For this purpose, regular time pulses are used to set bistable counting circuits in the main control unit, and the main programme is divided into segments that never exceed 1 ms. Following the completion of each programme segment, control is passed to the executive programme. This programme inspects the bistable counting circuits to decide whether to allow the main programme to continue, or whether the register programme is now due to process the next group of registers. By this means, the processing of any register is not delayed for more than 1 ms, and this ensures that the specified accuracy of signalling timing is maintained.

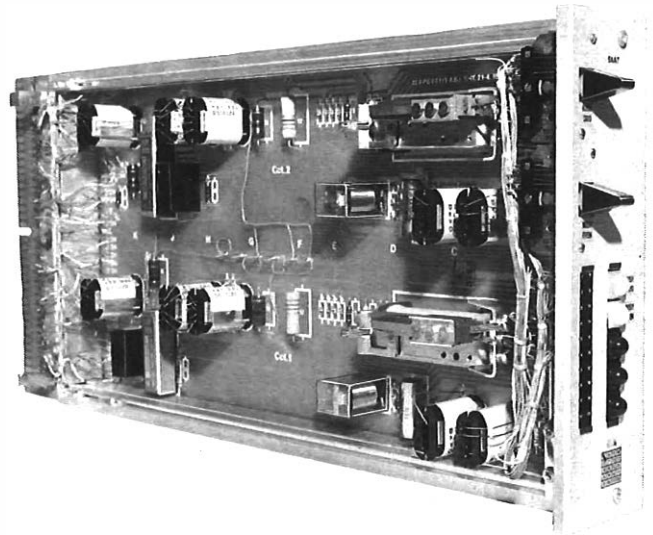

FIG. 11—TXE4 register plug-in unit showing two 10 pulses/s registers

### Working Storage

The main control unit includes both ferrite stores and stores comprising electronic bistable circuits. There is capacity for 16 kbit, arranged into 50 bit words, in the ferrite store associated with each main control unit. Each word contains 10 denary digits, coded in 2-out-of-5 form. Eight words are permanently allocated to each of the 36 registers, and a further 27 are available in a common pool. Some of the latter hold data that enable the main control unit to supervise the overall processing of registers; the remainder is available to supplement the store capacity of a register when it is being processed by the main programme. The electronic bistable stores operate in a non-destructive read-out mode, in contrast to the ferrite stores which, once read, have to be rewritten if the information is to be retained. Other bistable stores are used to indicate, for example, which of the 36 registers is being processed at a particular time.

### Registers

TXE4 register circuits are not equipped with permanent storage or translation facilities. These functions are performed in the main control unit by common processing. The registers contain a number of circuit elements which detect signals from, or connect signals to, a customer's line or a junction terminated on the exchange. Typical functions, for which individual circuit elements are provided in the register, are

- (a) reception of customers' or junction signalling,
- (b) detection of abnormal line-potentials,
- (c) detection of the calling party on shared-service lines,
- (d) provision of dial tone,
- (e) checking, in conjunction with the markers, path continuity within the switch network, and
- (f) pulsing-out to distant exchanges.

Two connexions are provided from each register to the switch network. One connexion being primarily for the receipt of signalling, and the other for pulsing-out. Both connexions are terminated on junction A-switches. The simplicity of the TXE4 registers is illustrated by Fig. 11. This shows a plug-in unit containing 2 separate loop-disconnect registers. Each register has an auxiliary card containing electronic control logic. Where multi-frequency signalling is required, further auxiliary plug-in units are necessary.

As the main control unit is associated with only one register at any time, common high-speed signalling and

information paths are provided between the main control unit and the associated group of registers.

The main control unit controls a register by sending a series of instructions; some of these are in the form of a question, to which the register responds *yes* or *no*. Fig. 9 shows how a main control unit connects with its registers via an equipment termed a *register instructor*. The information sent to the register instructor identifies the particular register concerned and the instruction to be sent to it. The register identity is decoded and the selected register is alerted by a signal on a register-number lead. The instruction is commoned to all the registers served by the register instructor, but only the alerted register will respond. The information path in the reverse direction is a common yes/no highway.

### PULSE GENERATOR

To synchronize the operation of the cyclic stores, main control units and markers, a central pulse generator is provided in each exchange. The required security of service is achieved by dividing the pulse generator into 4 identical sections. Each section contains a 168 kHz oscillator, giving a basic pulse interval of about 6  $\mu$ s. The oscillators drive a succession of 9 ring-counters, which progressively divide the frequency of the pulses generated. The cycle times of the ring-counters are set by the various timing requirements of the exchange equipment using the pulses. For example, main control units operate on a programme-step cycle-time of 12  $\mu$ s, whereas cyclic stores require pulses with cycle-times ranging from 48  $\mu$ s–156 ms. The oscillators and ring-counters are synchronized by majority-decision circuits acting on all

4 sections of the pulse generator. Signals from the ring-counters are further combined to produce the various pulse trains required, which are then distributed to the user equipment on pulse highways. To achieve further security, these highways are duplicated and, in some cases, quadruplicated. Comprehensive fault monitoring is provided by connecting some pulse highways in a ring, so that they return to the pulse-generator rack. This allows comparison of pulses at both the near and far end of these highways, and ensures that any highway or pulse-generation fault is detected.

### CONCLUSION

This second part has described in some detail the design and operation of the most important items of equipment in a TXE4 exchange, and has shown how they work together to set up and supervise calls. The third part of the article will discuss the different security arrangements found in the various items of equipment, and will describe the special features that have been included to assist exchange maintenance.

### References

- <sup>1</sup> GOODMAN, J. V., and PHILLIPS, J. L. TXE4 Electronic Exchange System, Part 1—Overall Description and General Operation. *POEEJ*, Vol. 68, p. 196, Jan. 1976.
- <sup>2</sup> BEASTALL, H., and POVEY, J. A. Telettraffic Studies of TXE4. *POEEJ*, Vol. 65, p. 251, Jan. 1973.
- <sup>3</sup> TIPPLER, J., LONG, R. C., and RIGBY, D. F. Electronic Telephone Exchanges: Speech-Path Control in Reed-Electronic Exchanges. *POEEJ*, Vol. 61, p. 103, July 1968.

---

## Book Reviews

*Electrical Installation Technology* (second edition). M. Neidle, T.ENG.(C.E.I.), F.I.T.E., A.S.E.E.DIP. Newnes-Butterworths. xvi + 381 pp. 254 ills. £3.90.

This book indicates that its aim is primarily to act as a textbook for technicians in the field of electrical installation work. The volume tries to cover a wide range of electrical engineering material. Inevitably, in trying to cover elements from fundamental concepts to high-voltage practices, and lighting and heating, as well as elementary electronics and management techniques, the treatment in many respects may well be regarded as superficial, and possibly does no more than create in the student's mind an awareness of a given specific subject. For example, the Ward-Leonard speed-control system is covered in about 12 lines, plus a sketch. Similarly, primary and secondary cells, and charging methods, can be spared only just over 6 pages, including drawings. With such attenuated treatment, supplementary study will be found necessary where any depth of information is needed by a student.

For many, however, the down-to-earth treatment of material, such as electromagnetism and simple d.c. and a.c. circuit theory, will be appreciated. This, when coupled with the brief descriptive material, will be adequate for those seeking a starting point in electrical theory, coupled with some practical applications. Worked examples are a good feature, clearly presented and easily followed, because short cuts have, wisely, been avoided.

This is a modest little volume that tends to attempt a great deal. Nevertheless, many students will welcome the very fact that an attempt has been made to cover so much material in one book.

C. R. N.

*Modern Communication Systems*. R. F. W. Coates. Macmillan. xi + 292 pp. 153 ills. Hard cover: £9.95; paperback: £5.95.

This book is written by a university lecturer for a 2-year course on communication-system engineering at Bachelor of Science degree level. It deals not only with the theoretical principles of various methods of telecommunication, but also with hardware and the consequent practical constraints imposed on these methods. There is no explicit statement of what the reader is expected to know, but it is evident that this includes, apart from the usual mathematics, acquaintance with elementary circuit theory, knowledge of what a decibel is, and similar fundamental expertise.

The topics covered include: the analysis and synthesis of waveforms, Fourier analysis, the Fourier transform, and energy-density and power-density spectra; information sources and channels, radio and line transmission, and the telephone network; envelope, angle, and pulse modulation (including pulse-code modulation (PCM), but not differential PCM nor delta modulation); coding for error protection; and the transmission of digital signals. The effect of noise is always considered, as is possible hardware, preferably of the integrated-circuit type. Each chapter has several exercises, and there is an illustrated table of Fourier-transform pairs, a collection of mathematical formulae, an up-to-date bibliography and an index.

No serious errors have been found, but it is a pity that students should be exposed to non-standard symbols; in particular, the logic symbols used in Chapter 6. However, the book is to be highly recommended as an introduction to the subject, giving a happy mixture of theory and practice.

W. E. T.

# The Millimetric Waveguide System: The Design, Production and Installation of the Waveguide

W. K. RITCHIE, A.R.C.S.T., C.ENG., M.I.E.E., and C. E. ROWLANDS, B.SC.†

UDC 621.372.81.09: 621.372.821.2.001.6: 621.391

*This is the second of a 4-part series of articles dealing with the design, development and future prospects of a TE<sub>01</sub>-mode main-network waveguide system developed as a joint venture between the British Post Office and British industry. The first article gave an overall description of the system; this article deals in greater detail with the design, production, installation and repair of the waveguide and duct. A small production plant has been established, and waveguide manufactured and installed in a 14.2 km field trial. It is considered that the field trial has established the basis for a soundly-engineered, cost-effective system which, on a single waveguide, could provide for the forecast traffic growth on any main route to the end of the century.*

## INTRODUCTION

TE<sub>01</sub>-mode waveguide has the following 3 outstanding transmission characteristics:

(a) an extremely wide bandwidth capability stretching from 30 GHz to more than 100 GHz, sufficient for up to 500 000 bothway telephone channels,

(b) a very low attenuation, typically 1.5 dB/km in the centre of the band and rising to only 2.5 dB/km at the higher frequencies, permitting repeater spacings in the range 20–30 km, and

(c) negligible signal distortion on high-bit-rate transmission.

The general technical feasibility of TE<sub>01</sub>-mode waveguide systems was demonstrated in the 1950s, but it is only in recent years that circumstances have combined to stimulate the development of waveguide systems that realize these characteristics in practical systems at competitive costs. A wide range of design options are open to the engineer and, as a result, different administrations have developed widely different systems. In the British Post Office (BPO), the aim has been to develop a sound cost-effective system which, while showing substantial savings if introduced into the current high-capacity network, also safeguards the future, whether that future makes modest or high bandwidth demands on the network. The outcome of the development is a simple waveguide-in-duct system of good transmission performance and relatively low production and installation costs.

During the development, a small waveguide production plant was set up in industry and the system has been assessed in a 14.2 km field trial, running from the site of the BPO Research Centre at Martlesham to the small country town of Wickham Market. The methods used in the design, production and installation of the waveguide in the field trial are considered to be a sound basis for an operational waveguide system, and largely constitute the subject matter of this article.

## WAVEGUIDE DEVELOPMENT

### Transmission Characteristics

The low attenuation possible in TE<sub>01</sub>-mode waveguide can be achieved only by operating the waveguide at very high

frequencies where many modes of propagation are possible. The main object of design is to minimize the coupling of power from the TE<sub>01</sub> mode, and to limit and control the flow of what power is coupled. Many thousands of unwanted (spurious) modes are possible, but fortunately, coupling is strong only to those modes close in order to the TE<sub>01</sub> mode. Attention must, therefore, be paid to the TE<sub>12</sub>, TE<sub>11</sub>, TM<sub>11</sub> and TE<sub>02</sub> modes; other spurious modes have little effect on transmission characteristics.

When the TE<sub>01</sub> mode encounters a dimensional imperfection in the bore of the waveguide, the field is distorted and power is coupled from the TE<sub>01</sub> mode into a series of spurious modes. The magnitude of the coupling is a function of the magnitude of the dimensional imperfection and the difference in phase constant between the TE<sub>01</sub> mode and the spurious modes. This power is largely lost and therefore increases the attenuation of the waveguide.

A small amount of the power flowing in the spurious modes is reconverted back to the TE<sub>01</sub> mode at subsequent discontinuities and, since each mode has a different group velocity, this reconverted power will have experienced a time change (generally a delay) relative to the TE<sub>01</sub> mode. This phenomenon is called *mode-conversion-reconversion distortion*; its magnitude is a function of the magnitude of the dimensional imperfections, the difference in attenuation between the spurious mode and the TE<sub>01</sub> mode, and the distance between the dimensional imperfections.

After many years of development, the following 2 forms of waveguide, giving desirable transmission characteristics, have emerged.

(a) *Helix Waveguide* In the helix form of waveguide, the conductive wall is formed of a close-wound helix of fine insulated wire. The TE<sub>01</sub> mode requires only circumferential conductivity and is substantially unaffected by the helix construction. Energy in the spurious modes, however, penetrates through the gaps between the helix turns, into a lossy dielectric layer where the energy is dissipated. In a helix waveguide design, therefore, both the differential-phase and differential-attenuation characteristics of the spurious modes can be beneficially altered in relation to the wanted TE<sub>01</sub> mode.

(b) *Dielectric-Lined Waveguide* In the dielectric-lined form of waveguide, a thin, lossless dielectric lining is applied to the inside wall of the waveguide. The field intensity of the TE<sub>01</sub> mode is low at the waveguide wall, while the field

† Research Department, Telecommunications Headquarters

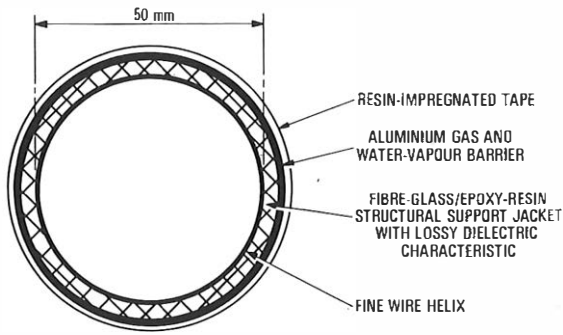

Not to scale

FIG. 1—Cross-section of helix waveguide

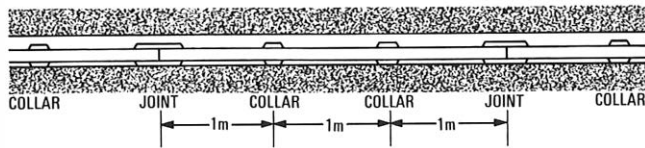

FIG. 2—Block diagram of waveguide in duct

intensities of the spurious modes are high; therefore, the differential-phase characteristics can be beneficially altered. The differential attenuations, however, are unaltered and, in general, it is necessary to intersperse the dielectric-lined waveguide with lengths of helix waveguide to give an adequate level of spurious-mode attenuation.

The 2 forms of waveguide have different transmission characteristics. The helix form, because of the high spurious-mode attenuations that are readily achieved, has the advantages of negligible signal distortion, a smooth attenuation/frequency characteristic and comparatively good tolerance to periodic dimensional imperfections. Dielectric-lined waveguide has the advantage of lower loss in route bends, as discussed later.

### Waveguide Design

A widely-based study was undertaken by the BPO, in conjunction with British industry, in an attempt to determine the best cost-effective design. From an initial consideration of methods of manufacture and possible waveguide structures, 15 forms of waveguide were chosen for initial evaluation; from these, 4 forms were selected for detailed cost/benefit evaluation, involving a study of transmission characteristics, design of production machinery, layout of production plant and detailed production costing. As a result of these studies, it was concluded that a form of helix waveguide with a fibre-glass/epoxy-resin jacket, supported inside a steel duct on simple collars attached to the waveguide was the most suitable design. Fig. 1 shows a cross-section of the waveguide structure, and the method of supporting the waveguide is shown in Fig. 2. The jacket is given a lossy-dielectric characteristic by the addition of fine iron powder to the resin. The aluminium layer prevents the ingress of oxygen and water vapour and also acts as an electrical screen.

Although many considerations were involved in the choice of this design, the main factors were as follows.

(a) The various layers forming the wall structure are all applied by reasonably simple winding operations on a precision reusable mandrel. The structure is, therefore, relatively cheap to manufacture, good dimensional tolerances can be achieved and production spreads are small.

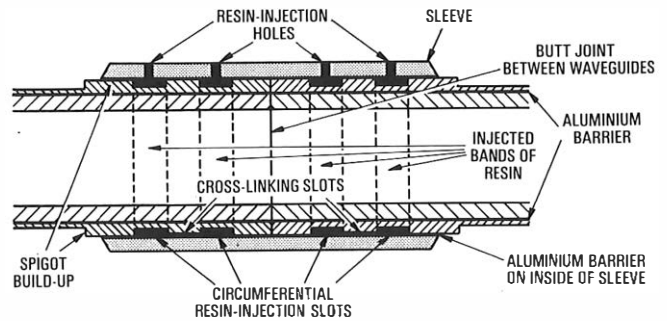

FIG. 3—Waveguide joint

(b) The choice of helix waveguide brings the benefits of negligible signal distortion, a smooth attenuation/frequency characteristic and relatively good tolerance to periodic dimensional imperfections. It does, however, have the disadvantage of somewhat higher attenuation in route bends, but it was estimated that the extra attenuation would reduce the repeater separation by less than 25%. Since the cost of repeaters is a small proportion of the total system costs, the cost penalty is small.

(c) Because the waveguide is light and relatively tolerant of periodic deformations, simple support and installation methods can be used.

(d) The waveguide has many practical advantages, such as lightness, resilience, ease of handling, ease of jointing and inherent corrosion resistance.

The waveguide structural design can be improved by placing a majority of the glass fibres longitudinally in the jacket, rather than at 45° as in the field-trial waveguide. Because the glass fibres take the bending stress in this improved design, rather than the resin matrix, a waveguide with about twice the stiffness modulus is produced, and the effect of duct deviations in straightness and waveguide sag between support points is much less significant. Prototype machines to produce this form of waveguide have been developed, and will be incorporated in the production plant later.

### Design of Joint

The waveguide joint is an important system element and must satisfy a number of stringent criteria. It must

- (a) provide good straightness and cross-sectional alignment,
- (b) have adequate strength in torsion, compression and tension,
- (c) be gas-tight, and
- (d) be simple and quick to make, requiring no special skill from the joiner.

A double-spigot-and-sleeve type joint, shown in Fig. 3, was developed by the BPO and adopted by BICC Ltd. for production waveguide. Precision spigots are produced on the ends of each section of waveguide by building up extra layers of resin and tape, and then machining on a rotating precision mandrel. Two circumferential resin-injection slots and a cross-linking slot, as illustrated in Fig. 3, are cut in each spigot. The sleeves are produced on oversize precision mandrels and therefore have the same degree of accuracy as the waveguide. The spigot and sleeves are a close interference fit.

The joint is assembled by thrusting the spigots into the sleeve so that the 4 resin-injection holes in the sleeve align with the resin-injection slots in the spigots and the cross-linking slots are approximately opposite the resin-injection

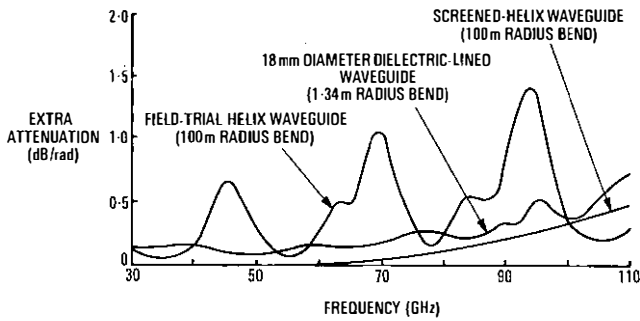

FIG. 4—Extra attenuation due to bending

holes. A specially developed resin is injected through one hole and the joint is filled when resin appears through the other hole. The joint is heated by a hot-air blower to cure the resin.

This joint design generally performed well in the field trial, but it did not consistently achieve the low value of axial tilt desired. The spigot-turning machine in the factory is currently being redesigned to improve the accuracy.

**BENDS IN WAVEGUIDE**

There has long been a widely-held belief that even modest route bends cause a very large increase in waveguide attenuation and that this imposes a severe restriction on the viability of waveguide systems. This belief dates from the early theoretical days of waveguide studies, but examination of helix waveguide in practical routes has shown that the increase in attenuation is quite small. For example, in the field-trial route, the increase in attenuation is only 18%, even at the most critical frequency of 96 GHz.

In route bends, there is a cyclic exchange of power between the  $TE_{01}$  mode and a series of spurious modes, of which the  $TM_{11}$  mode is the most important. In helix waveguide, the spurious-mode power tends to be absorbed, while in dielectric-lined waveguide, it is allowed to flow and recombine so that

the attenuation increase is small, but there is a signal-distortion penalty. In the field-trial waveguide, due to the wide spacing between the helix and the aluminium screen, there is maximum absorption of the spurious-mode power at particular frequencies, resulting in the extra attenuation due to bending curve shown in Fig. 4 for a 100 m radius bend.

Theory and experiment have recently shown that, by moving the screen much closer to the helix, the loss peaks can be moved out of the transmission band, resulting in the extra attenuation due to bending characteristic shown for the screened-helix waveguide in Fig. 4 for a 100 m radius bend. The spurious-mode attenuations of this waveguide are less than the field-trial waveguide, but are still much higher than for dielectric-lined waveguide. The screened-helix waveguide should permit routes to be followed with numerous bends down to 100 m radius of curvature, which is the comfortable limit of bending radius imposed by the rigidity of the steel duct.

A waveguide bend has been developed which enables routes with very sharp changes in direction to be followed. The bend takes the form of an 18 mm bore diameter dielectric-lined waveguide, with a curvature profile following a cosine law giving an average radius of curvature of 1.34 m. The bend is connected to the 50 mm diameter waveguide by short tapers, 0.5 m in length. A 90° bend of this form can comfortably fit into a square manhole of 2 m sides. Fig. 4 also shows the measured attenuation characteristic of such a bend including the tapers. Development is continuing with the object of reducing the loss above 85 GHz, which is primarily due to coupling to the  $TE_{12}$  mode.

**WAVEGUIDE MANUFACTURE**

A method of waveguide manufacture was developed at the BPO Research Centre, in which the various layers forming the waveguide structure of Fig. 1 were wound on to a precision 50 mm diameter mandrel. BICC Research and Engineering Ltd. undertook a contract to design, commission and operate a small production plant based on this method of manufacture, and to produce 16 km of waveguide for evaluation in a field trial.

Fig. 5 shows the factory layout and Fig. 6 is a general

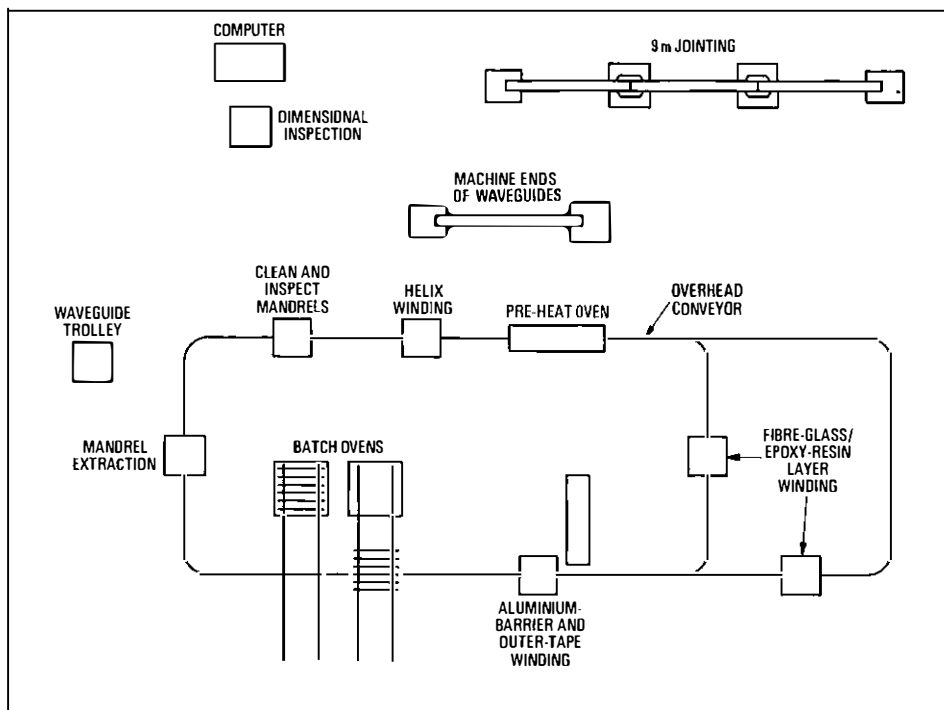

FIG. 5—Block diagram of floor plan of waveguide production plant

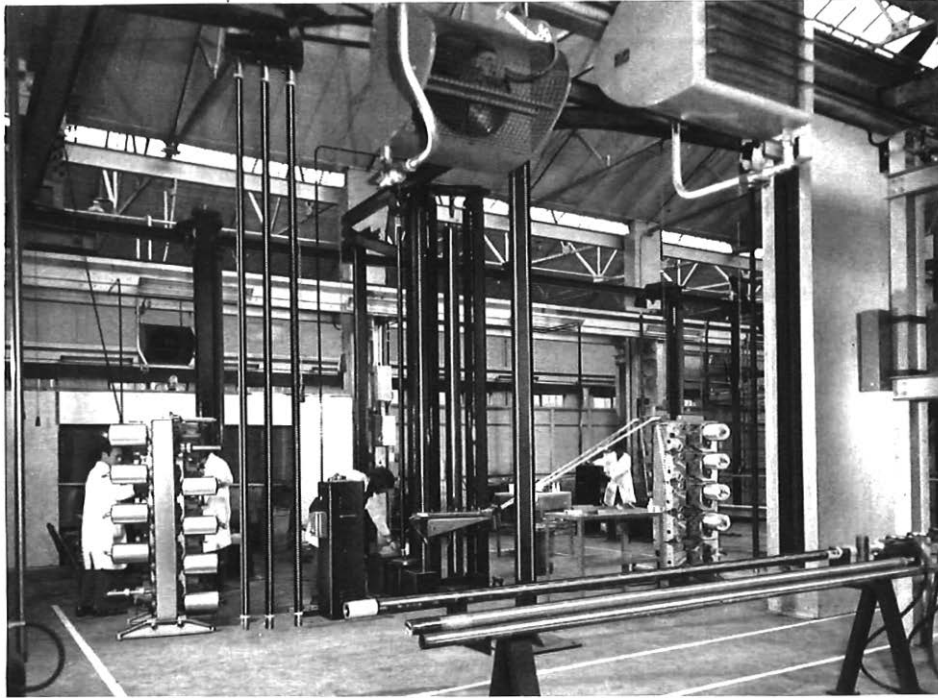

Fig. 6—General view of the waveguide production plant

view of part of the factory. The plant is organized round an overhead conveyor system, from which the 3 m long mandrels are hung and along which they are transported between manufacturing stations. Vertical operation, which is unusual in wound glass-fibre construction, was adopted after consideration of resin flow, handling, space restriction, effect of mandrel sag and convenience of process operation. A brief description of the plant follows.

After cleaning and inspection, the mandrels are transported to the wire-helix winding machine, where 2 wires are wound simultaneously to form the helix. The winding time for a 3 m mandrel, including start and termination of the wires, is 15 min. A servo-controlled winding head maintains good uniformity of pitch and each wire pay-off is also servo-controlled to maintain a constant wire tension.

In the next stage of manufacture, the fibre-glass/epoxy-resin structural layer is applied, 2 machines being used since this is the slowest operation. To assist the flow of resin, the mandrels first pass through a linear pre-heat oven. Eight glass rovings, each of 2400 glass fibres, are fed from tension-servo-controlled pay-off heads through a resin-impregnation trough. At the exit of the trough, the rovings pass through a metering die to control the amount of resin, and are then assembled into a flat band to be wound at an angle of 45° on the rotating mandrel. Several passes are made to build up the jacket thickness of 3.3 mm.

In the next stage, the aluminium layer and outer resin-impregnated-tape layer are applied, and the ends built up for subsequent machining of the precision joint spigots. The mandrels are then assembled into batches of 36 for overnight curing in large ovens.

The cured lengths of waveguide are pushed off the mandrels and the mandrels re-enter the production cycle. The 3 m lengths of waveguide are transported by trolley to a machine where the precision spigots are cut, and then to a station where the cross-section and straightness are accurately measured by bore gauges, the results being recorded and processed by a small dedicated computer. Waveguide lengths within specification are passed to a station where three 3 m lengths are jointed together to form a 9 m length; this is the

longest length that can conveniently be transported and handled in the field.

The plant as it now stands is capable of manufacturing waveguide at a rate of 20 km/year if operated on a single-shift basis, and 35 km/year for double-shift operation. The production rate could be raised to perhaps 50 km/year for double-shift operation if some of the critical machines were augmented and there was some alteration to the work flow.

### Quality Control

Good quality control, particularly of dimensional tolerances, is essential in TE<sub>01</sub>-mode waveguide manufacture. In the field-trial production, there was 100% inspection of straightness variations and joint tilt, and 10% random sample inspection of the less critical cross-sectional variations. As an illustration of quality-control requirements, a histogram of waveguide curvature throughout the field-trial production is shown in Fig. 7. This is the most critical parameter deter-

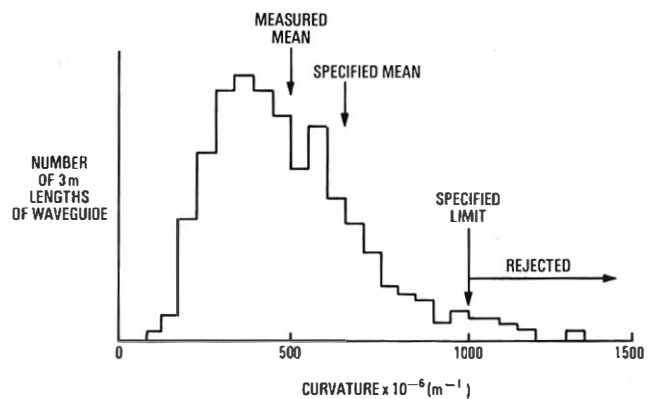

Fig. 7—Histogram of number of 3 m lengths of waveguide against curvature throughout field-trial production



mining the waveguide transmission characteristics. It can be seen that the overall production mean was well within the specified mean and that only a small proportion (8.5%) was rejected as outside the specification limit.

## DUCT INSTALLATION

The waveguide lies loosely on its support collars at 1 m intervals inside a 100 mm diameter steel duct, as illustrated in Fig. 2. The duct controls the general straightness of the waveguide, and serves to decouple the waveguide from the effects of earth movements and pressures. It also acts as a first line of defence against damage.

The new feature of duct installation for waveguide is the straightness requirement. The straightness of standard seam-welded steel duct is very good, and the main problem has been to develop methods of installation and jointing that place the duct in the ground without stressing the duct to the extent that it is unacceptably distorted. This is greatly facilitated by the high strength and stiffness of steel duct. The waveguide duct is similar to standard BPO steel duct (Duct No. 70), except that the ends are plain finished ready for welding and a limit is placed on the thickness of the polyethylene sheathing.

The field-trial duct was installed by a method that used wooden stakes at 2 m intervals in the bottom of the trench, on which were fitted laser-aligned duct saddles. Although this method gave good straightness alignment, it proved to be expensive, and the regular saddle separation resulted in an appreciable periodicity in the duct straightness profile. The duct was jointed by welding, with the ends held in a hydraulically-operated alignment jig. This method of jointing proved to be very effective, giving good alignment, excellent gas-tightness and high strength. It is now 3 years since the field-trial duct was installed and several repeat measurements of straightness have shown negligible change.

Less expensive duct-installation methods have recently been developed. The aim has been to produce a range of techniques that will permit quick and effective installation in all practical route situations. The following 3 basic installation methods have been developed.

(a) In the most universal technique, an open trench is dug and the bottom levelled by hand. The duct is jointed at the side of the trench and positioned over the centre of the trench on wooden beams lying across the trench. A roller attached to the arm of a trench-digging machine (JCB) is run along under the ducts, raising it slightly to allow the beams to be removed, and the duct then descends to the bottom of the trench in a smooth wave-like action. Fig. 8 shows this operation. The straightness of the duct is measured by a simple external gauge which can be wheeled along the duct; if the straightness specification is satisfied, the trench is back-filled in the normal manner. The random deviations from the intended line achieved by this method represent an extra attenuation of about 0.4 dB/km at 100 GHz.

(b) Alternatively, 100 m or more of duct is jointed above ground, in line with the trench, and pulled down a ramp into the trench. The length pulled in is jointed to the length already installed by a specially-developed mechanically-assembled joint. The sliding action of the duct helps to level the trench bottom and the pulling action tends to keep the duct straight, but the method has the limitation that it requires twice the working length of the first method. The random deviations from the intended line achieved by this method represent an extra attenuation of about 0.3 dB/km at 100 GHz.

(c) For suitable locations, a high-powered mole-ploughing technique has been developed, in which the vertical and horizontal profiles are separately controlled. Up to 400 m of duct can be installed at a time. This method gives good alignment and is quick, but it can be used only where there is a reasonably unobstructed run. The hire cost of the



FIG. 8—Duct being placed in trench by roller technique

equipment is high; therefore, the method is most suitable for cross-country routes where the installation can proceed smoothly and quickly. The random deviations from the intended line achieved by this method represent an extra attenuation of about 0.2 dB/km at 100 GHz.

The deviation of the curvatures quoted for each of the installation methods is that which should be obtained in reasonably unobstructed situations, but this will not always apply in urban and suburban situations where obstructions have to be avoided and duct must sometimes be installed in short lengths. Estimates have been made for route-planning purposes of the deviation of the curvature that will be obtained in all the different route situations.

## THE WAVEGUIDE INSTALLATION

The waveguide is delivered from the factory to the site store pre-jointed into 9 m lengths. Seven lengths are strapped together with binding bands to form a bundle, and simple gantries are provided to load and unload the articulated lorry trailers used for transport. For the field-trial installation, the site store also formed the supply and service base, with the waveguide being dispatched to the installation site in special containers as required.

The layout of the equipment at the installation site is shown in Fig. 9. The jointed waveguide is fed into the main-route duct via an inclined steel feeder duct, which runs from the access manhole to just below the ground surface. For installation, the line of this inclined duct is extended above ground to present the waveguide at a convenient height for jointing. Twin jointing stations are used, arranged in series, with each unit housed in a small caravan complete with all the necessary tools and services. A third caravan contains the pressurization equipment needed to fill the waveguide with a tracer gas mixture for leak-testing purposes. Site power is provided by diesel generators.

The jointing sequence is straightforward. A 9 m length of waveguide from the transportation container is fed through the rearward jointing position, to place its leading edge in the forward jointing station adjacent to the trailing end of the waveguide that has already been installed. The second 9 m length of waveguide is brought forward into the rearward caravan and each jointer makes a joint. The whole length of waveguide is pressurized to 70 kPa (10 lb/in<sup>2</sup>) with a 5% sulphur hexafluoride (SF<sub>6</sub>) in air mixture. The newly jointed 18 m length of waveguide is thrust into the duct by the hydraulic thruster located in the manhole, pausing for each joint to be leak tested as it passes the detection equipment in the leading caravan. When thrusting and testing of the 18 m

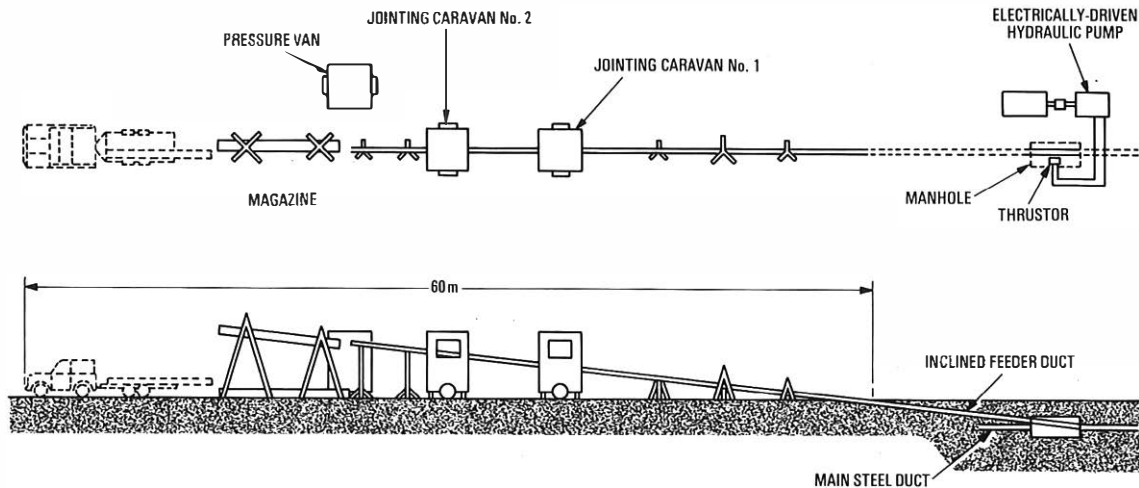

FIG. 9—Plan and side elevation of jointing equipment at installation site

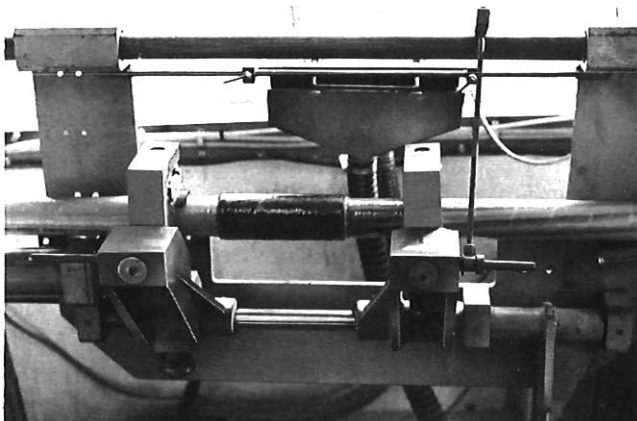

FIG. 10—Jointing frame mounted in caravan

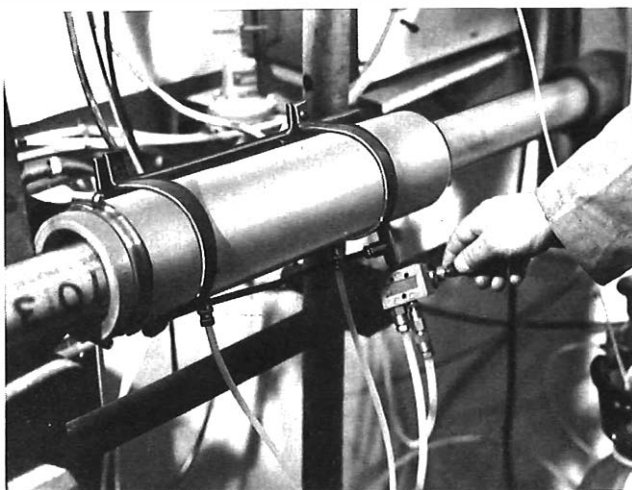

FIG. 11—Measurement hood for leak testing

length is complete, the waveguide is depressurized and the cycle repeated. A complete cycle takes 45 min.

The foregoing gives the general outline of the installation procedure. Some of its more important operations are described below in greater detail.

### Method of Jointing

The jointing method is the same in both the factory and the field. The field equipment is shown in Fig. 10 mounted on a simple frame which can be adjusted to cope with waveguide entering the caravans at different heights. A small hydraulic ram is used to thrust the twin machined spigots into the sleeve to form the joint. The assembly is heated by hot air in a heating hood which totally encloses the joint.

The resin is injected from the hand-operated injection gun into the inner resin-injection holes in the sleeve to fill the spigot rings. At the end of the curing period, the joint is mechanically and pneumatically complete, with the resin fully cured.

### Leak Testing of Individual Joints

It is essential that the completed waveguide is gas-tight and, during the installation process, joints are examined for leaks. The interior of the waveguide is pressurized to 70 kPa with a 5% mixture of  $SF_6$  in air, and a search made for  $SF_6$  outside the joints. Each joint is located in turn inside the measurement hood shown in Fig. 11. Inflatable rubber seals at the end of the hood seal the joint within the hood. Any  $SF_6$  gas that leaks from the joint is carried by a gentle flow of compressed air to the detecting instrument. To make a measurement, the operator merely presses a number of interlocked buttons in sequence. The hood is purged, the calibration of the instrument checked against a standard and the measurement made. The whole process takes less than 1 min.

### Movement of Waveguide along the Duct

The waveguide is pushed into and along the duct by a hydraulic thruster, erected in the manhole as indicated in Fig. 9. The thruster is a simple, reciprocating hydraulic ram of 1 m stroke. It pushes via a spring-loaded gate on the trailing edge of the jointing sleeves and intermediate collars. A length of 1.2 km can be thrust from any single location.

Thrusting the waveguide confines all the installation operations to a single site and minimizes the manpower requirements. However, the waveguide can be easily winched along the duct, or pushed through intermediate manholes to avoid difficult installation situations. Winching was tried in 2 locations on the field trial to gain experience. No problem was encountered, the waveguide moving smoothly and quickly.

### Tensioning the Waveguide

After installation, the waveguide is stretched by a calculated amount. This extension maintains the waveguide in permanent tension throughout the annual temperature cycle and prevents snaking in the duct due to thermal expansion.

### Fitting of Manhole Components

To complete the waveguide route, the bridging sections, which link the installed tensioned sections in the manholes, must be fitted. On the field-trial route, special components have been provided for the detailed assessment required. For example, at each manhole, remotely-controlled waveguide short circuits are installed so that the attenuation performance of each manhole-to-manhole section can be measured. The bridging pieces of waveguide are fitted with flanged joints for easy removal, and extensive gas-monitoring facilities have been provided.

### GAS PRESSURIZATION OF THE WAVEGUIDE

There are 2 significant atmospheric absorption effects in the frequency range 30–110 GHz: a large peak with a maximum attenuation of 16 dB/km centred on 60.5 GHz caused by oxygen, and a much smaller contribution from water vapour over the whole bandwidth. To eliminate these effects, and provide a stable and uniformly low-loss transmission medium, the waveguide is pressurized with oxygen-free dry nitrogen. Nitrogen was chosen because it is plentiful, relatively cheap and non-toxic.

A gas-flow system is preferred for the waveguide, in contrast with the static pressurization systems normally adopted for main cables. The dynamic system has the following advantages.

(a) The gas in the waveguide is changing, and leakage of oxygen and water vapour will tend to be removed.

(b) The presence of such contaminants in the nitrogen stream can be readily detected at the exhaust point.

(c) Waveguide has a very low pneumatic resistance and therefore faults are quickly apparent at the supply point.

To prevent the ingress of oxygen and water vapour and to minimize the nitrogen demand, the waveguide must be gas-tight. The aluminium barrier reduces diffusion through the waveguide wall, and the joint is similarly specified to minimize both leakage and ingress. The specification leakage requirement of less than 2000 mm<sup>3</sup>/(min km) when the waveguide is pressurized to 70 kPa was achieved for all the sections of the field trial.

The internal nitrogen pressure makes due allowance for the air pressurization of the external steel duct. The field-trial duct is pressurized with dry air at 35 kPa from standard compressors at each end. Accordingly, the waveguide pressure at the gas inlet (Martlesham) is 54 kPa, and a positive pressure differential is maintained at all points.

So far, the gas-pressurization system has been very successful. The pressure drop along the 14.2 km route is minimal, being about 3.5 kPa, and the total leakage less than 5 × 10<sup>5</sup> mm<sup>3</sup>/min at 54 kPa; this leakage is known to

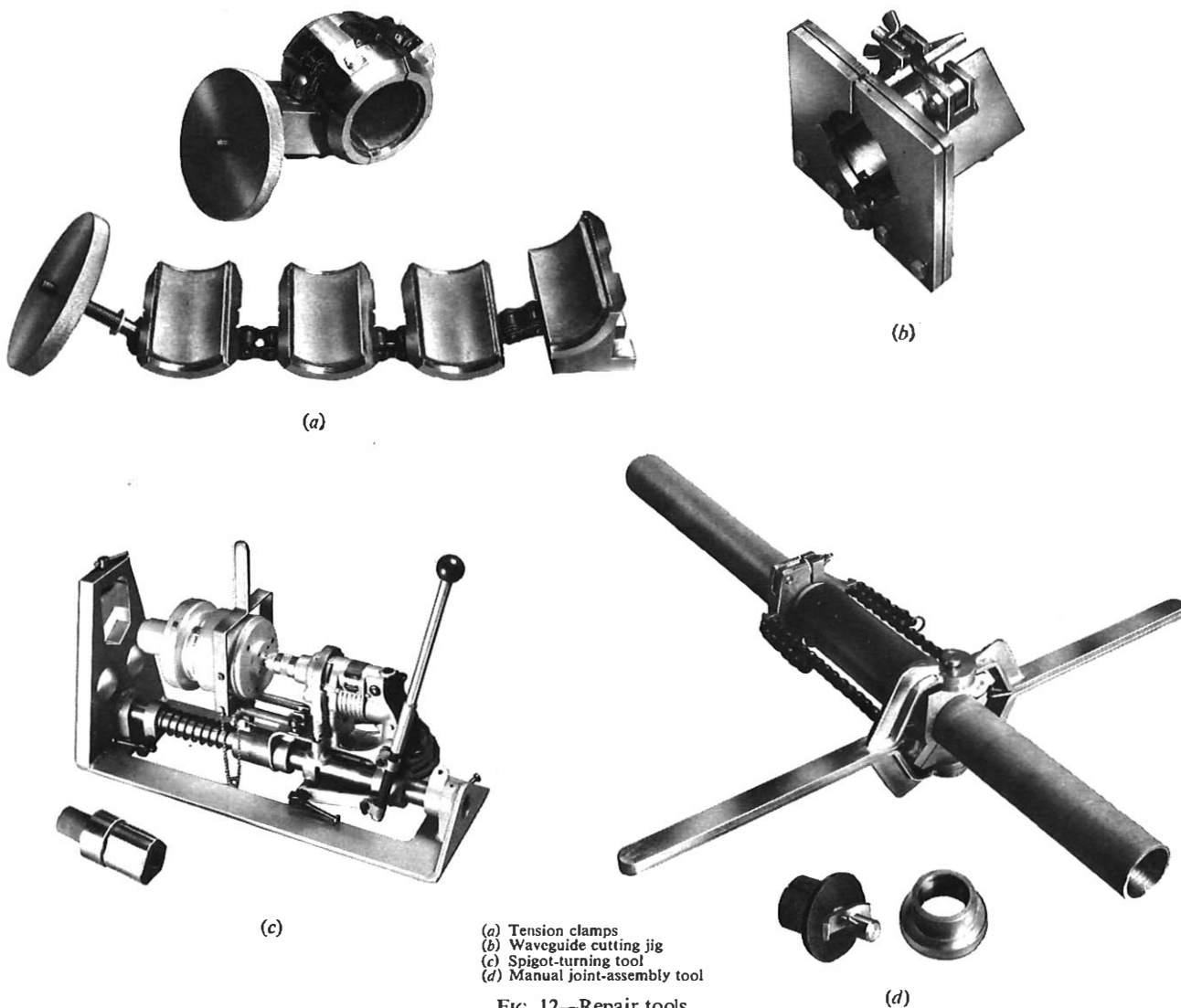

(a) Tension clamps  
(b) Waveguide cutting jig  
(c) Spigot-turning tool  
(d) Manual joint-assembly tool

FIG. 12—Repair tools

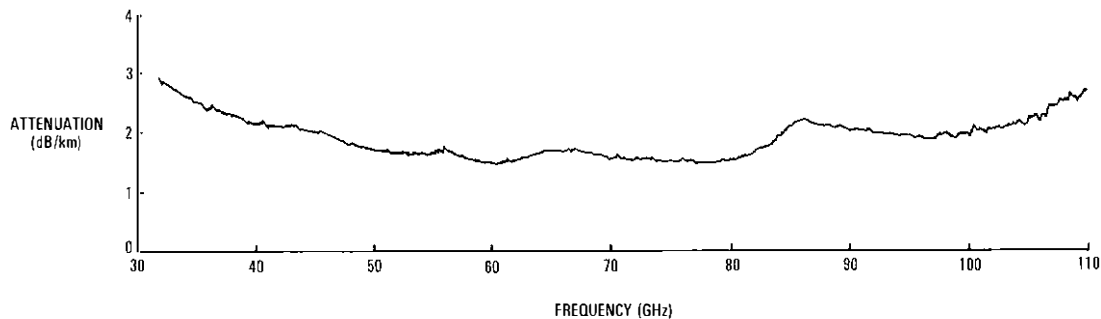

FIG. 13—Measured attenuation of 11 km of field-trial route

be almost entirely due to the manhole components included for the experimental programme. Oxygen has proved to be simply removed. The concentration is steady at less than 20 parts/million at the end of the 14.2 km route and has negligible effect. The water-vapour concentration at the exhaust point is 1200 parts/million and again has no transmission significance.

### REPAIR TECHNIQUES

The repairing of faults simply and quickly is vital for an operational system. Work in this important area is being actively pursued at present and the brief description here is restricted to the repair tools that have been developed.

Fig. 12(a)–(d) shows the special tools. In most cases, a fault, once located, will be repaired *in situ* by excavation and replacement of the damaged duct and waveguide. The steel duct is cut away by making twin longitudinal cuts followed by circumferential cuts at the ends of the damaged section. If the waveguide is not severed, it will still be under tension and, to prevent it springing back on cutting, the tension locking clamps (Fig. 12(a)) are applied adjacent to the cut duct ends. A pre-determined length of waveguide, which includes the damage, is cut away using the cutting jig (Fig. 12(b)) and a hacksaw. The replacement section, already cut to length, is joined to the original with a pair of the standard joints. Jointing spigots are built up on the cut ends of the original waveguide by applying a resin-impregnated tape bandage and heat curing. The precision spigot is then machined *in situ* with the turning tool (Fig. 12(c)). This device machines the outside diameter of the spigot relative to a precision internal mandrel, cuts the resin-injection slots and faces the end of the waveguide in one simple operation. A manually-operated joint-assembly tool (Fig. 12(d)) pushes the spigots and sleeves together, and resin is injected and cured in the normal way. Though the operation sounds complex, in practice, it is straightforward and a waveguide repair can be comfortably completed in under 2 h.

### THE MEASURED PERFORMANCE

The method of attenuation measurement has already been described elsewhere<sup>1</sup> and is not described in this article. Fig. 13 shows the attenuation/frequency characteristic for some 11 km of the field-trial route. It includes waveguide sections laid in carriageway, along verges and across country, and is typical of the curvatures that practical routes will include.

The small spikes on the characteristic are believed to arise

from the measurement equipment and are not evident when the individual transmission channels are examined. However, the broad peaks are related to the waveguide. The small peaks at 45 GHz, 65 GHz and 90 GHz are the bending loss peaks mentioned earlier (see Fig. 4), while the peaks at 56 GHz and 86 GHz are caused primarily by periodic sag in the waveguide and duct.

### THE FUTURE

The Martlesham–Wickham Market field trial has shown that circular waveguide can provide a low-loss, very broadband transmission medium when produced and installed under practical engineering conditions. The ongoing development is seeking further cost reductions and a still lower transmission loss. For the waveguide itself, the principal areas being pursued are

- (a) the rebuilding of the factory spigot-turning machine, to reduce the axial tilt at joints and improve the manufacturing consistency,
- (b) the development of stiffer waveguide with the majority of the glass fibres laid longitudinally along the waveguide; this will reduce periodic sag and further improve the strength and robustness of the waveguide,
- (c) the development of new, cheaper methods of duct installation that remove duct periodicity, and provide a quick and simple, yet accurate, installation, and
- (d) the development of the screened-helix waveguide with its reduced loss in bends.

The waveguide of 1976 is very different from the simple, cylindrical copper pipe whose limitations were discussed in this *Journal*<sup>2</sup> over 16 years ago. The problems then foreseen have now been overcome, and the pipe may soon spread widely beneath fields, roads, verges and footpaths to provide a high-capacity digital traffic highway for the future.

### ACKNOWLEDGEMENTS

The authors wish to acknowledge both the assistance of their BPO colleagues in the preparation of this article, and the permission of BICC Ltd. to discuss the manufacture and installation of the field-trial waveguide.

### References

- <sup>1</sup> BOMER, R. P. A Computer-Controlled Attenuation Measurement System for TE<sub>01</sub>-mode Circular Waveguide from 32–110 GHz. *IEEE Transactions*, IM-23, No. 4, p. 386, Dec. 1974.
- <sup>2</sup> TAYLOR, F. J. D. Long-Distance Transmission by Waveguide. *POEEJ*, Vol. 52, p. 213, Oct. 1959.

# The Experimental Changes of Practice Committees: ECOPCs 2 and 3

F. A. HORNE, R. E. G. BACK, E. CROFT, K. DAVEY and R. E. S. COLLETT†

UDC 614.8.008.1:658.2

*This article explains the purpose of the 2 Experimental Changes of Practice Committees (ECOPC 2 and ECOPC 3), and seeks to describe, in broad outline, their role in the development and implementation of improvements in working practices, procedures and organization.*

## INTRODUCTION

The article on Experimental Changes of Practice Committee 1 (ECOPC 1)<sup>1</sup> explained that, while all 3 ECOPCs are concerned with improving productivity and service, ECOPC 1 concerns itself mainly with questions of safety and the development and proving in the field of new items of external plant, new tools, vehicles and mechanical aids. ECOPCs 2 and 3, in their respective fields (which are broadly external work and internal work, respectively), concern themselves with monitoring the development and proving by field trials of new procedures, new working practices, and changes in the organization and planning of work. They provide a forum at which management representatives, with expert knowledge of the topics under discussion, can explain the proposed changes at an early stage to union representatives and thrash out what their effects will be, what problems they pose for the staff and what solutions should be adopted to deal with these problems. The ECOPCs do not deal with grading issues arising from new practices; these are the province of the Standing Joint Committee (SJC) on grading, but the discussions on the ECOPC give both parties a useful background which helps them when dealing with grading questions arising from changes in practice. For example, the grading of the officers to take charge of the pole-erection units,<sup>2</sup> rodding and light-cablings units<sup>3</sup> and, more recently, the heavy-cablings units have all been processed in this way.

For these units, ECOPC 1 concerned itself

- (a) with the development and proving of the new specialized aids as items of plant,
- (b) that they were well adapted to the purpose proposed, and
- (c) that any safety hazards were taken care of before they went into large-scale use.

ECOPC 2 concerned itself with

- (a) the crew size,
- (b) the functions to be carried out,
- (c) the practices and procedures to be adopted, and
- (d) the effect on the rest of the external works organization of introducing these new highly-productive aids.

The SJC agreed a tentative grading for the crews of the first trial vehicles and, later, confirmed this tentative agreement before full national introduction of the new items took place.

These semi-formal discussions are supplemented by visits by the ECOPC members to field trials to see new methods in operation, and to discuss informally with the staff carrying them out what they and the local management think of them.

The process is time consuming and comes in for much criticism on this account. On the other hand, it does ensure that the problems which changes of practice inevitably pose for both management and staff get a thorough airing, and that answers are thrashed out before large-scale implementation takes place. Some proposed changes are found wanting under this ruthless examination and do not go on into full national implementation.

## THE ROLE OF ENGINEERING PRODUCTIVITY COMMITTEES

ECOPCs 1, 2 and 3 operate at national level; at Telephone Area level, there are Engineering Productivity Committees (EPCs) which deal with local productivity improvements. These committees can refer ideas upwards for national consideration if it is considered that they have national application. In addition, when a nationally-sponsored trial is taking place in an Area, the local EPC provides a forum for local discussions about it. EPCs can also invite the experts who are sponsoring a trial, and members of the staff who are taking part in it, to attend their meetings to explain it and answer questions. The EPCs therefore provide a means of direct 2-way communication between the sponsors of a trial and the local staff representatives. Finally, towards the end of a trial, the EPCs concerned are asked to produce a joint report giving both local management and local staff views on the trial. These reports from the Areas taking part in a field trial are important in helping the national ECOPCs to reach an agreed conclusion.

## THE SOURCES OF IDEAS FOR IMPROVED PRACTICES

New ideas for improved practices can come from anyone, anywhere. Area EPCs can generate them; so can local management or staff. However, most of the major ideas come from specialist groups whose job it is to review current practices and procedures, and to see if there is a more productive way of carrying them out. Just as Value Analysis Division in the Purchasing and Supply Department and divisions in the Telecommunications Development Department of the British Post Office (BPO) look at how things are made to see if they can be made more cheaply, so certain staff

† Mr. Horne and Mr. Davey are respectively the Chairman and Vice-Chairman of ECOPC 2; Mr. Back and Mr. Collett are respectively the Chairman and Vice-Chairman of ECOPC 3; Mr. Croft is a member of both Committees

in Telecommunications Management Services Department, in the operational departments, and in Regions and Areas are employed to look at the way work is done to see if it can be done more efficiently.

Some ideas are purely local in application since they relate to localized problems and situations, and the aim is to ensure that such ideas are progressed locally. However, the methods of providing telephone service are very similar the whole world over; so it is hardly surprising that good solutions tend to have very wide application and, sooner or later, nearly everyone finds their way to them. That does not mean that there is one universal best answer for everything, but what is a good solution in one place is quite likely to be of help to a lot of other people elsewhere who have a similar problem. The aim of the ECOPC machinery is to ensure that all potentially productive new ideas are given a proper airing, are properly evaluated and, if successful, are adopted locally when the problem and its solution are purely local, and nationally when the idea has universal application.

The processes by which productive new ideas are generated and progressed by those people for whom it is a full-time job are complex, with different approaches interacting and helping each other.

### THE NEW-TECHNOLOGY APPROACH

One approach could be called the *new-technology* approach. A new material, for example, may make it possible to change the design of an existing product so that it can be produced more cheaply. The new product may also permit a change in the way some job is done in the field and this, in turn, may require a different organizational approach. Even a dearer material may be worth using if it makes the work much easier. Plastics duct, for example, when first introduced was dearer than earthenware duct, but was much lighter so that

- (a) it could be handled in longer lengths,
- (b) it could be transported to site in large bundles,
- (c) it did not break so easily, so losses due to breakage were less,
- (d) it could be cut more easily, and
- (e) joints between lengths were simpler.

Hence, although the basic plastics material was more costly than the clay from which earthenware duct was made, there were overall cost advantages in changing from earthenware to plastics. Now, with the greatly increased cost of running the oil-fired kilns in which earthenware duct is made, plastics duct is actually cheaper ex-works than earthenware and the other advantages are a bonus.

As a cable-sheath material, on the other hand, plastics are cheaper than the lead used previously and, as a bonus, the finished cable is lighter and immune to corrosion damage. A cable that is lighter and has lower friction when pulling-in can be handled in much longer lengths, so making it possible to reduce the number of joints. By exploiting all these advantages, 2 men equipped with a rodding and light-cabbling vehicle now handle external cabling jobs that used to require 4-5 men when using the old methods and lead-sheathed cable, and they do them at much less cost.

Finally, when the new-type cable is in its new-type duct, the jointers make new-type wire joints and enclose them in new-type sheath closures. In short, the technological change to plastics materials has affected the work of every part of the external work force and, in the process, has made possible some considerable gains in productivity.

### THE WORK-STUDY APPROACH TO IMPROVED METHODS

The other approach is to start by systematically studying and analysing how jobs are done now. This approach is called *work study*; a name given to a battery of techniques for

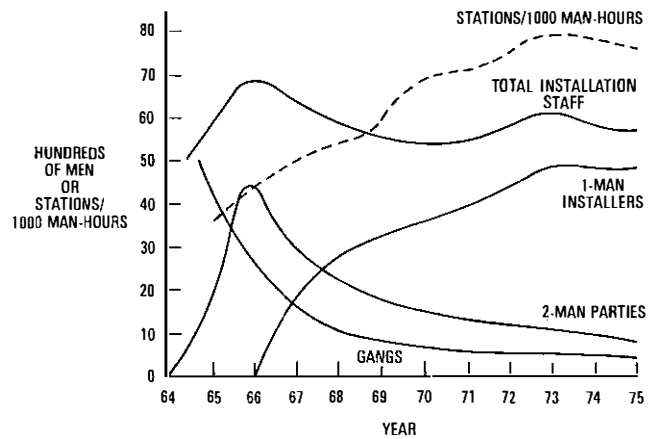

Fig. 1—Changes in organization of installation gangs, 2-man parties and 1-man installers 1964-75

recording and analysing how work is carried out, for measuring how long each task takes with existing and possible alternative methods, and for developing better ways of doing jobs.

In practice, the 2 approaches to improved methods (that is, exploiting technical innovation and work study) tend to go on in parallel and to complement each other, since new methods often require some new technical development to enable them to work, and new technology often cannot be exploited without new working methods—a sort of chicken-and-egg situation. In each case, the key to achieving worthwhile savings is to examine those operations on which large numbers of man-hours are expended, as these offer the greatest potential savings. Jobs where the work load is expected to grow considerably in the near future are also well worth examining, preferably before the work load has built up. This explains why the external works and installation fields, where the BPO used to have many thousands of men in gangs, attracted early attention and why, in recent years, attention has been turned to circuit provision, Datel installation, the impact of exchange modernization on internal construction and maintenance work, to mention only a few.

Other activities attract attention because, although they may not directly employ very large numbers of staff, they affect the working efficiency of very large numbers; for example, stores procedures, control procedures, plant records of all kinds, management-information systems such as work-progress reporting, planning, estimating and forward programming of work, the organization of controls, and so on. All these are grist to the mill for ECOPCs 2 and 3, since improvements here can have a major impact on efficiency.

### CHANGES OF PRACTICE INTRODUCED

A list of all the changes processed through the ECOPC since its role changed in 1963 and its split into ECOPCs 1, 2 and 3 in 1965 is impressive and a summary of the more important changes is given in the Appendix to this article. It can be seen that the biggest changes in the past have been in the customer installation, external works and external maintenance fields. While there is still considerable scope for improvements in efficiency in these fields of work, the weight of attention in recent years has moved increasingly towards internal maintenance and internal planning and works.

It is hardly surprising that customer installation and external works gangs attracted most attention in the early 1960s, because they offered ready scope for improvement. BPO practices for constructing overhead lines had changed little for decades; picks, shovels and men were the main "mechanical aids". However, pole-erection units<sup>2</sup> were being

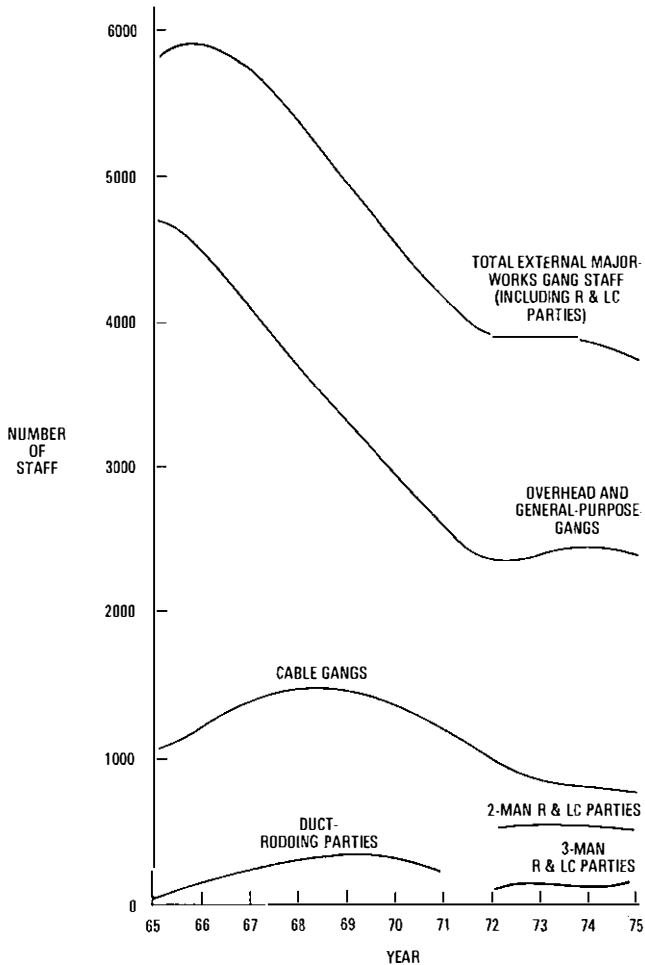

R & LC—rodding and light-cabling  
 Fig. 2—Changes in external works gang staff 1965-75

developed by adapting Canadian designs which enabled specialized 2-men units to do most pole provision, recovery and renewal—tasks for which, traditionally, gangs of men had been employed. Increasing penetration of telephone service into the residential sector was bringing about a marked increase in the scale of distribution point (DP) provision and a consequent reduction in the work needed to connect each new customer to the nearest DP. New materials such as lightweight, plastics-insulated drop-wire were being introduced. By taking advantage of all these factors, customer installation parties with no poling capability became a viable proposition. Hence, the change from gangs to 2-man parties and 1-man installers was a logical development in which work study and technological change both had a part to play, and each complemented and helped the other; the overall effect, which is illustrated in Fig. 1, has been remarkable.

In the external works field, as already mentioned, duct-rodding machines and new cabling aids were also being developed and, together with plastics-sheathed cable, made it possible for 2 men to do what previously had required a cabling gang of 4-6 men. At about the same time, a study of jointers at work had shown that the age-old custom of every jointer having a mate was not justified, except where a second man was needed for safety reasons, and that these represented a minority of working situations. The external field was therefore ripe, and by comparison with other advanced telephone administrations overripe, for change. For example, the UK introduced 1-man installers many years after the USA, Canada and Sweden, though it must be pointed out

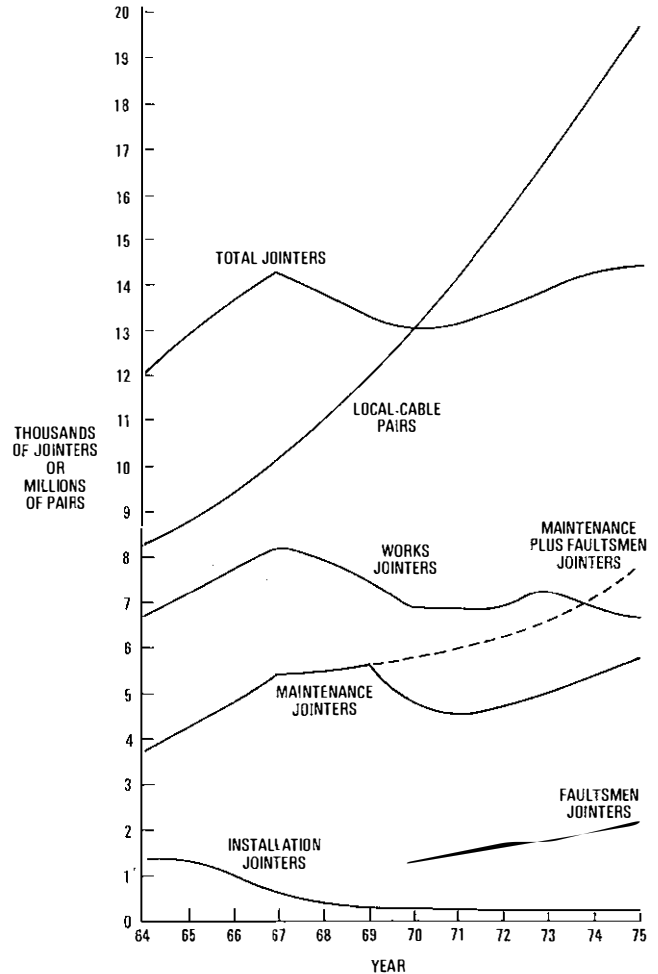

Fig. 3—Changes in cable jointing staff and growth in the local-line network 1964-75

that these countries were (and still are) far ahead of the UK in telephone penetration, and this has a marked effect on the amount of work required to connect each new customer.

Some idea of the extent of the changes in the external work force in the last decade is given in Figs. 2 and 3, while Figs. 4, 5 and 6 show how the UK telephone system as a whole has grown with relatively little growth in total engineering man-hours.

### THE ORIGIN OF THE PRESENT ECOPCs

It was the realization in *National Productivity Year, 1963* that the UK was so far behind some other countries which led the then Engineer-in-Chief, Sir Albert Mumford, to trigger off much of the change that has happened in the last decade. One of his first actions was to propose that the ECOPC, which was then operating in a more limited role, should expand its role to what it is now, so that the staff concerned could be kept fully informed and play a full part through their representatives. He realized that success in introducing the changes that were so obviously necessary would depend not only on the skills of the people who developed them, but also on

(a) the refining process of trying out new practices under working conditions,

(b) modifying them as necessary to incorporate contributions from both management and staff in the light of experience, and

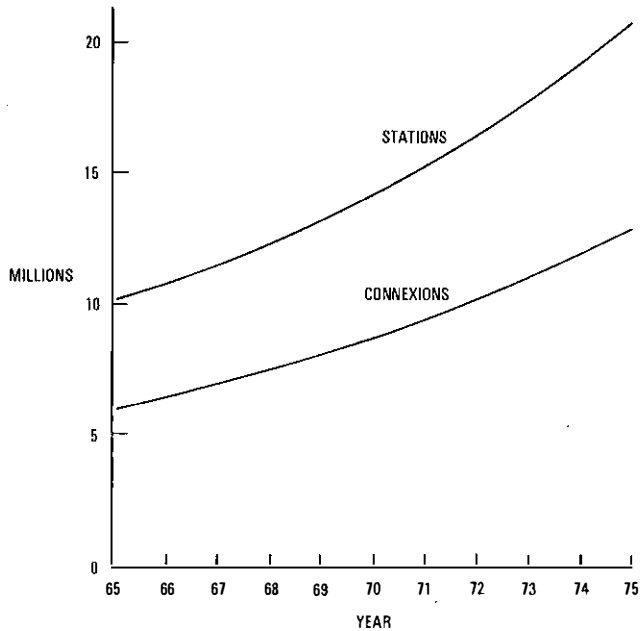

FIG. 4—System growth 1965-75

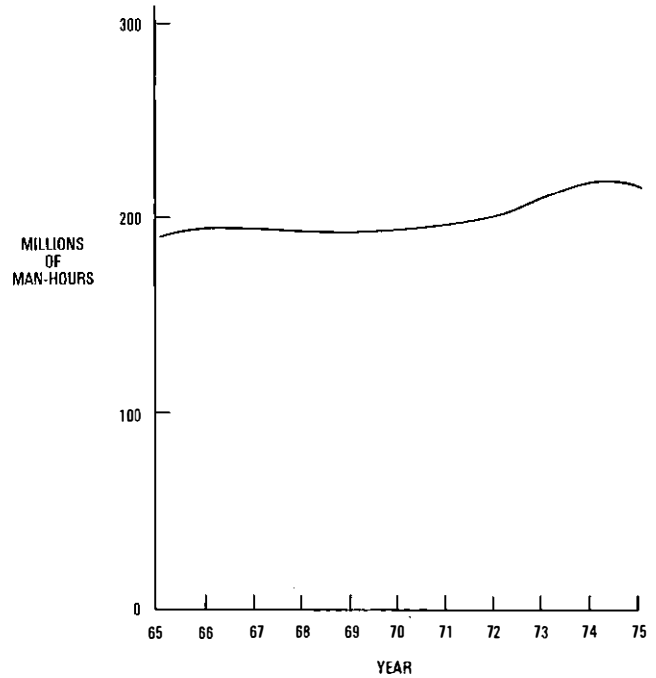

FIG. 6—Growth of total engineering man-hours 1965-75

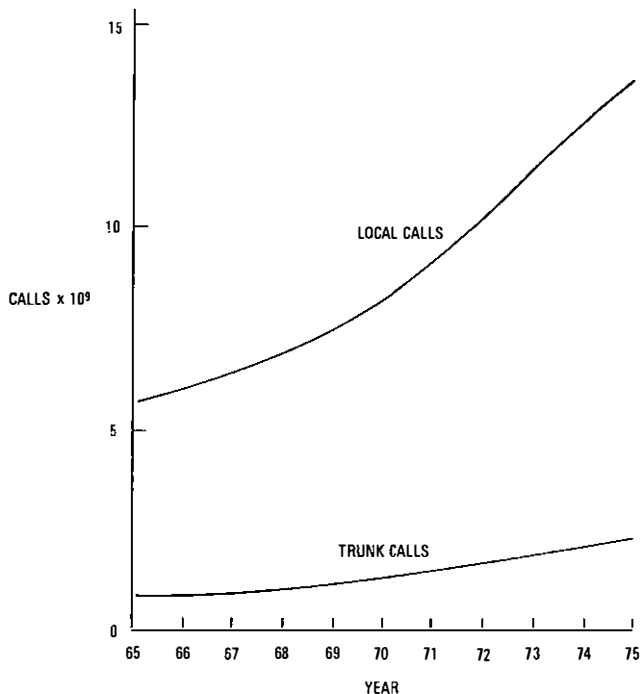

FIG. 5—Call growth 1965-75

(c) ensuring, by consultation with the unions, that full account was taken of the point of view of the staff as a whole.

The very big changes which have taken place in the customer installation, external works and maintenance fields would hardly have gone so smoothly if it had not been for the part played by ECOPCs 2 and 3.

Consultation on this scale has its problems. Both sides must have a genuine will to progress towards improved service and lower costs. It could not work unless both management and unions had similar aims, coupled with mutual respect and trust; otherwise it would degenerate into argument, confrontation and stalemate. Argument there is on

the ECOPCs, but only rarely confrontation and stalemate. This is shown by the fact that the changes that have taken place since 1963 in working methods and in the make-up of the engineering work force have been achieved without an industrial upset of any kind, or a single redundancy. Nevertheless, the question is bound to be asked, "Why do the unions co-operate in all this; what is in it for them?" The short answer is that it is in the interest of all who work for the Business to keep it efficient and profitable. Unless the services customers want can be provided when they are wanted and at prices customers are prepared to pay, the Business cannot thrive and prosper and all will suffer the consequences. This applies not just to the BPO and its employees, but to large sections of the UK generally. At the same time, unions have a duty to safeguard the legitimate interests of the staff in the Business whose work and careers may be affected by change. The ECOPCs and EPCs bring both sides together to thrash out answers to these mutual problems.

#### CODE FOR ENGINEERING CHANGES OF PRACTICE AND DEVOLUTION

It is not surprising that a considerable amount of custom and practice has built up in the engineering field of the Telecommunications Business on how changes should be initiated, how field trials should be conducted and how major national changes of practice should be implemented. It was recently agreed that these procedures should be incorporated in a *Code for Engineering Changes of Practice* (Telecommunications Instruction M4 H1000), applicable to all the ECOPCs. The object of the Code is to provide a framework within which staff and management can continue to co-operate in making the telephone service more efficient. The Code explains the assurances that are given to staff co-operating in organization and methods studies and field trials; assurances that the sole purpose is to develop more effective working practices, that the staff who will be taking part will be given adequate prior notice and afforded the opportunity to question how they will be involved.



The Code leaves Regions and Areas complete freedom to deal with local changes while advising Telecommunications Headquarters of the essentials of any new ideas they have developed, so that others who have problems in the same field can be informed and can benefit from their experience. The advantages of this multilevel approach are that the initiative and enthusiasm of staff at all levels can be mobilized to contribute to overall efficiency, and local ideas can be adopted in the Area or Region concerned as soon as they are seen to be advantageous.

## THE FUTURE

The role of the ECOPCs and EPCs is by no means finished. On the contrary, major changes are in store as we move more deeply into exchange modernization, new ways of organizing maintenance, new transmission and signalling systems, new cable systems, new customer apparatus and new customer services. All mean changes for somebody; changes mean problems and the ECOPCs and EPCs exist to help to sort them out. Given a constructive, forward-looking approach on both sides, there is no reason why, together, management and staff should not continue to solve these problems to the mutual benefit of both. If any change is needed it is that the process should be speeded up. By comparison with other advanced countries, we are still much too slow to move forward to new and more productive ways of working, and because of this our living standards are lower and the service we give to customers is poorer than they need be. Past improvement in productivity has benefitted the staff in the form of higher pay, the business in higher growth and a better return on capital, and the country in good communications at lower prices. It is in the interest of all three that the process should continue.

## References

- <sup>1</sup> CLINCH, C. E., WILLITT, A. H., and MARKWELL, T. E. The Experimental Changes of Practice Committees: ECOPC I. *POEEJ*, Vol. 68, p. 144, Oct. 1975.
- <sup>2</sup> HUNT, R. J. The Pole-Erection Unit. *POEEJ*, Vol. 60, p. 93, July 1967.
- <sup>3</sup> MARTIN, R. W. A Rodding and Light-Cabling Vehicle. *POEEJ*, Vol. 64, p. 22, Apr. 1971.
- <sup>4</sup> DOHERTY, M. Mechanization of Cable Recovery. *POEEJ*, Vol. 62, p. 10, Apr. 1969.
- <sup>5</sup> HARDING, J. P. A Wire-Jointing Machine for Subscribers' Cables. *POEEJ*, Vol. 62, p. 31, Apr. 1969.

## APPENDIX

### Summary of the More Important Changes Processed through the ECOPCs

#### Customer Installation

- (a) *Installation Labour Cost-Control System* This provided management with more meaningful labour cost information for most customer installation work. It greatly simplified the paper work for field staff by abandoning the unit construction cost system.
- (b) *Stop-Start Advice Note (AN) Procedure* This enabled telephone service to be transferred from an outgoing to an incoming customer at minimum cost; the work of recovering and reproviding the installations is avoided, even when there is a long break in service.
- (c) *Streamlined AN Procedure* This simplified the circulation of AN copies, reduced the work of collating, checking and filing AN copies, and abolished acceptance testing of new lines.
- (d) *Reduction in Gangs, Change to 2-Man Installation Parties* All pole-erection work was transferred to pole-erection units and a few residual gangs. Two-man installation parties could then do all the rest of the work required to provide straightforward telephone services; that is, overhead wiring, simple fitting, underground services, simple cabling and jointing work, cabinet and pillar jumpering, and jumpering in unattended exchanges and PBXs.
- (e) *Lightweight Aerial Cabling by 2-Man Parties* This enabled 2-man installation parties to erect and joint lightweight aerial cable with certain limitations on size and weight.
- (f) *One-Man Installers* With the aid of a drop-wire dispenser, these can do virtually all simple telephone installation work, including overhead wiring, simple fitting, cabinet and pillar

jumpering, jumpering at unattended exchanges and PBXs, and some simple jointing work.

- (g) *Reorganization of Customers' Fitting Work* This changed the customers' fitting organization to make it more productive.
- (h) *Appointment Plan and Speed-of-Provision-of-Service Statistics* These enabled sales staff to arrange appointments with customers for installation staff; the statistics measure degree of success in making appointments and in giving the promised service.
- (i) *Customer Works Groups* Planning, co-ordination and execution groups were set up to deal with PABX and complicated customer installations including Datel and private circuits.
- (j) *Subscribers' Carrier WB900 (I + I)* This enables 2 customers each to have exclusive service on one local cable pair.
- (k) *Objective Interval Plan* This provides for more effective programming of fitters' work in installation controls.
- (l) *Customer Planning and Works Procedure* This provides detailed engineering estimates, works instructions and cost data for the larger and more complicated customer installation jobs including PABXs. (Under field trial.)

#### Internal Works

- (a) *Planning and Works Control (Internal)* This provides improved methods for the compilation and control of internal works estimates; it also supplies management information on planning, execution and performance.
- (b) *Internal Works Programming* This enables internal works to be programmed and executed more efficiently.
- (c) *Estimates for Works Specifications* This provides basic hour rates for work associated with equipment modifications.

#### Stores

- (a) *Engineering Stores Control and Pricing (ESCAP)* This provides computer control of stock levels, automatic replenishment under computer control and computer pricing of stores issues.
- (b) *Control and Utilization of Stores for Works* This simplifies stores ordering, provides more effective control of stores for internal works and caters for valuation of works-order stores holdings.

#### Circuit Provision

- (a) *Circuit Provision Control Procedures* This provides basic hour rates for work, and supplies management with improved performance and service statistics.

#### External Works

- (a) *Planning and Works Control (External)* This provides improved methods for the compilation of external works estimates; it also supplies management information on planning, execution and performance.
- (b) *External Works Programming* This enables external works to be programmed and executed more efficiently.
- (c) *Rodding and Light-Cabling Vehicle* This enables 2 men to do most rodding and cabling jobs including dealing with stoppages.
- (d) *Heavy-Cabling Equipment* This is a 2-vehicle unit operated by 4 men, in which a boom-type winch reduces setting-up time in manholes and a self-loading cable carrier allows cabling with drums still on the carrier.
- (e) *Cable-Recovery Unit*<sup>4</sup> This recovers old cable; a power-driven chopper cuts the cable into short lengths for disposal.
- (f) *Long-Length Cabling* Much longer lengths of polyethylene-sheathed cable can now be pulled-in, so reducing the number of joints and manholes required.
- (g) *Introduction of Solo-Jointers* No mate is needed, except where necessary for safety.
- (h) *Machine Jointing No. 4*<sup>5</sup> This joints local-cable conductors, both copper and aluminium, using crimped sleeves. It is power driven and its application to junction cables is on trial.
- (i) *Jointing Jig* This is used for jointing distribution cables; it eases setting-up and jointing cables and lessens operator fatigue.
- (j) *Pair Identification Equipment* This is a quick method of identifying cable pairs between the main distribution frame and the cabinet. Random joints can be made, pairs identified and then sorted into order at termination points only.
- (k) *Computerized Balancing* Jointing schedules for balancing audio junction cables are produced using a computer to select pairs and to print-out the actual schedules used by jointers in the field.
- (l) *Pole-Erection Units* These are self-contained vehicles operated by 2 men, and used for erecting and recovering poles.

#### Maintenance

- (a) *Subscribers' Apparatus and Line Maintenance Reorganization* This provides a more effective organization for subscribers' apparatus and line maintenance.
- (b) *External Plant Maintenance Centres (EPMCs)* The EPMC

provides a central point in each Telephone Area for recording, analysing and disseminating information on external plant maintenance beyond the capacity of the repair service controls.

(c) *External Plant Protection* This introduced Plant Protection Officers to replace plant-watchers and revised procedures to ensure better safeguarding of BPO plant.

(d) *Automatic Night Routining* This enables all switches in Strowger exchanges to be tested nightly under time-switch control, and gives an automatic print-out of faults found.

(e) *Routining at Night with Centralized History (RANCH)* Currently on trial, RANCH provides a means of recording and analysing faults found by night routining.

(f) *Fault Reference Centres* These provide for recording and analysis of all failures on switching networks, and identification of common failure points.

(g) *Computer Aided Maintenance Project (CAMP)* CAMP tested the application of computers to a variety of maintenance tasks; for example, traffic recording and analysis of failures.

(h) *Regional Electronic Service Centres* These provide a repair service on a regional basis for items such as electronic circuit boards.

(i) *Measurement and Analysis Centres (MACs)* Currently on trial, MACs provide improved arrangements for analysing failures and monitoring service.

(j) *Bank-Cleaning Machines* Power-driven bank-cleaning aids have replaced the old manual tools.

(k) *New Telegraph Maintenance Statistics* These enable faults and maintenance attention to be related to machine usage, and not just to the calendar.

---

## Book Reviews

*Telephony and Telegraphy* A. S. F. Smith, B.SC.(ENG.), C.ENG., M.I.E.E. Oxford University Press. 282 pp. 236 ills. Boards £4.95, paper £2.20.

The general structure of this book remains unchanged since the first edition was reviewed (*POEEJ*, Vol. 63, p. 226, Jan. 1971). New material covering the basic concepts of matrix switching and common control has been added, while sections dealing with manual systems have been deleted. These changes keep the work in step with the 1973 City and Guilds of London Institute (CGLI) syllabus for the Telephony and Telegraphy A examination, reproduced at the beginning of the book. The updating should revive the book's appeal to candidates who intend to acquaint themselves with the essential subject matter of the syllabus. In common with the original sections of the book, the treatment given to the new material is well chosen.

The author's teaching experience proves most useful in covering each subject in sufficient, but not excessive, depth. This should prove attractive to the examination-oriented reader, who will also benefit from the conciseness and clarity of both text and drawings.

The new cover photograph, an illustration of a crossbar switch, reflects the fresh material added to the book, but it is a pity that good photographs have not replaced some of the inadequate line-drawings in the book. This point was criticized in the review of the first edition, but none of the points brought out in that review, including the fact that page xiii, to which the reader is repeatedly referred, is not numbered, have been picked up in this second edition. More criticisms could now be added to those given earlier. For instance, the last line of print has been omitted from the foot of page 225. Some undue haste must have been attached to the final preparation of this edition because the numerical references to other sections and figures, which are sprinkled liberally throughout the book, contain so many errors as to mar an otherwise useful feature. Most of these numerical errors are attributable to the changes in section numbering accompanying the second edition.

With one small exception, namely, contact wear, the coverage of the CGLI syllabus is excellent. The allied subject of spark-quenching could also be improved by a slightly deeper treatment in the early part of the book. British readers, who will be studying the TXK1 system when they progress to Telephony B, may be disappointed to find the crossbar mechanisms explained in terms of Ericsson and Pentaconta equipment.

Finally, the "Cinderella" subject of exchange power-plant at the end of the book has much to commend its structure and content, but the space devoted to the chemistry of secondary cells could, with advantage, be replaced by some information on voltage characteristics, leading up to the

requirement for close control of the input voltage to a fully-floated power plant.

The book's shortcomings are relatively minor, however, and it can be recommended as giving one of the shortest but most adequate descriptions of the Telephony and Telegraphy A syllabus.

C. H. J. F.

*Radio and Line Transmission A*. (Second edition.) D. C. Green, M.TECH., C.ENG., M.I.E.R.E. Pitman Publishing. xiv + 318 pp. 289 ills. £4.00.

This is an updated edition of an excellent textbook first published in 1968 to cover the Radio and Line Transmission A syllabus of the City and Guilds of London Institute (CGLI) Telecommunication Technician's Course. In this second edition, the original chapters devoted to aerials and power supplies have been deleted and new chapters on field-effect transistors (FETs) and integrated circuits have been added. In addition to the new chapter on FETs, chapter 10, on resistance-loaded amplifiers, has been revised to include the use of FETs. Although simple semiconductor theory, FETs and integrated circuits are not included in the current CGLI Radio and Line Transmission A syllabus, the inclusion of these subjects in this type of textbook is both logical and necessary.

Earlier omissions in the first edition, on the treatment of load lines and class-A, class-B and class-C operation of transistor and valve amplifiers, have been corrected, and the subject matter in other chapters has been updated, including the deletion of some obsolete material.

If one is to raise a small criticism of this edition, it is the failure in chapter 2 to distinguish between the difference in the audio bandwidths used for the transmission of commercial-quality speech over cables and over high-frequency radio-telephony circuits. The former is 300–3400 Hz and the latter is 300–3000 Hz. This becomes important when the student reaches chapter 16.

As in the first edition, each chapter deals fully, yet economically, with a specific section of the syllabus; there is little cross-referencing from one chapter to another, and the contents and order of each chapter have been chosen to provide a logical approach to the subject of radio and line transmission. Theory and practice are nicely balanced, and there are numerous worked examples in each chapter, and a good selection of updated CGLI examination questions at the end of each chapter.

In all, this a first-class textbook for any student preparing for the CGLI examination in Radio and Line Transmission A, or for any student wishing to study the basic principles of radio and line transmission.

P. N. P.

# Multiplexing for a Digital Main Network

E. R. BRIGHAM, C.ENG., M.I.E.E., M. J. SNAITH, B.A., and D. M. WILCOX, T.ENG.(C.E.I.), M.I.T.E.†

UDC 621.395.74:621.396.218:621.395.49

*This article describes the stages of multiplexing required to multiplex from the 2·048 Mbit/s primary digital rate to 120 Mbit/s and to 140 Mbit/s, with particular reference to the multiplexing equipment developed for the British Post Office 120 Mbit/s digital line system which is currently on field trial.*

## INTRODUCTION

Multiplexing can provide a means of combining many signals so as to use economically the available transmission capacity of a medium. Hence, analogue transmission of telephony signals has evolved a frequency-division-multiplexing (FDM) hierarchy, in which multiplex equipment is used to assemble individual channels into groups, groups into supergroups, and supergroups into hypergroups, before transmission over a higher capacity system. Similar considerations in digital transmission have resulted in a hierarchy using time-division multiplexing (TDM), in which orders in the hierarchy are identified by their digit rate, measured in bits/second, rather than the bandwidth, in hertz, familiar in FDM.

One digital hierarchy which has been recommended by the International Telegraph and Telephone Consultative Committee (CCITT) and adopted by the European Conference of Posts and Telecommunications Administrations (CEPT) is based on 2·048 Mbit/s, the rate generated by a 30-channel pulse-code-modulation (PCM) multiplex. The orders in the hierarchy are as follows:

First (Primary) Order—	2·048 Mbit/s,
Second Order—	8·448 Mbit/s,
Third Order—	34·368 Mbit/s,
Fourth Order—	139·264 Mbit/s.

The British Post Office (BPO) has developed a 120 Mbit/s transmission system for use in the UK network, and multiplex equipment to assemble fourteen 8·448 Mbit/s tributaries to a rate of 120 Mbit/s has been developed concurrently (see Fig. 1).

## TIME-DIVISION MULTIPLEXING

### Multiplexing Synchronous Signals

TDM permits a number of different signal sources to use the same transmission medium by giving each source access to the whole transmission path for a period of time. To understand how this principle can be realized, a time interval of one digit time-slot is defined as the time allowed in the multiplex for the transmission of one bit. A synchronous digital multiplex equipment could be devised in which  $n$  independent binary signal streams, operating at the same rate  $T$  bits/second, form the input tributaries to the multiplex equipment. Each of the  $n$  parallel input tributaries, therefore, contains  $T$  digit time-slots per unit time interval, and the multiplex output must generate  $nT$  digit time-slots in the same time interval. That is, the multiplex output would be exactly  $n$  times the input rate, and the duration of an output digit time-slot would be  $1/n$  of the duration of an input digit time-slot.

The method recommended by CCITT, and used in the BPO, to assemble the multiplex output signal is digit interleaving; that is, the output contains one digit from each input in turn, giving a sub-sequence in the multiplexed signal that repeats

† Telecommunications Development Department, Telecommunications Headquarters

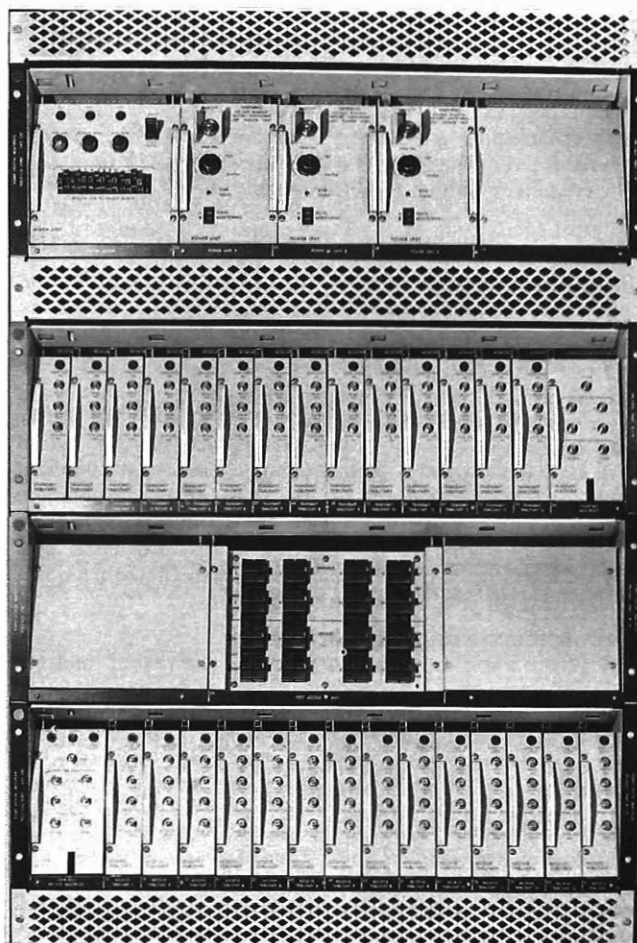

FIG. 1—The 8 Mbit/s to 120 Mbit/s multiplex equipment

every  $n$  digits. An alternative is to interleave blocks of digits from each tributary; however, digit interleaving is the most economical in terms of hardware used for storage.

A digital demultiplex equipment must be able to determine which digit time-slots are associated with which tributary. Thus, a predetermined and recognizable binary sequence is transmitted periodically to align the demultiplex equipment. This principle leads to the definition of a *frame*, which is a set of consecutive digit time-slots in which the position of each digit time-slot can be identified by reference to a frame-alignment signal. Additional digit time-slots to contain the frame-alignment signal are generated at the output of the multiplex by operating at a rate greater than  $n$  times the input rate. To preserve the continuity of the digit-interleaved sequence at the output, the block of digits containing the frame-alignment signal is made equal in length to  $n$ , or a multiple of  $n$ , digit time-slots, and is always followed by a digit from tributary one.

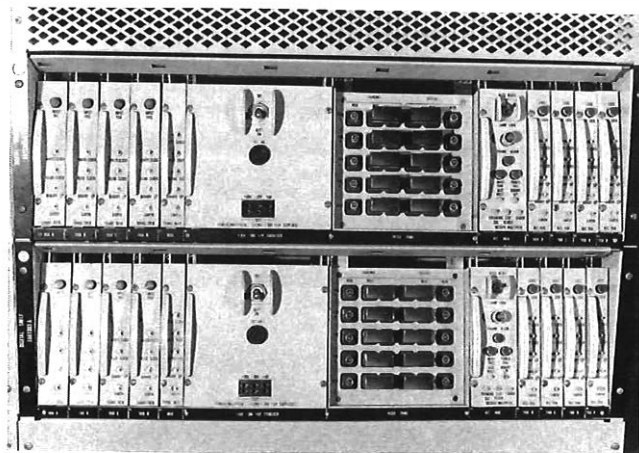

FIG. 2—Two 2 Mbit/s to 8 Mbit/s multiplex equipments

The multiplexing method so far described can accept only synchronous input tributaries, since any deviation from the nominal input or output rate causes unwanted digit time-slots to be created or wanted digit time-slots to be lost.

### Multiplexing Non-Synchronous Signals

The multiplexing method recommended by CEPT and adopted by the BPO allows non-synchronous, but plesiochronous†, signals to be multiplexed by using a process known as *justification*\*. This principle has been applied in the multiplexes at the second, third and fourth orders.

An important requirement to be considered when multiplexing plesiochronous signals is that, if loss of information is to be avoided, the multiplex must generate a sufficient number of digit time-slots at its output to accommodate tributaries that are operating faster than their nominal rate, although still within the permitted tolerance. For each level of the hierarchy, a frame structure is defined with a fixed number of digit time-slots used to contain

- (a) the frame-alignment signal,
- (b) information from the tributaries (an equal number for each tributary),
- (c) justifiable digits (one per tributary), and
- (d) justification-control digits (an equal number for each tributary).

The frame-alignment signal defines the start of each frame and, since the frame has a fixed format, defines the position of each digit time-slot in the frame. Each of the justifiable digit time-slots can be used to carry one bit of information from a tributary, or can carry a non-information digit. The content of each justifiable digit time-slot (that is, whether or not it contains an information bit from a tributary) is signalled to the distant demultiplex equipment by a code contained in the justification-control digit time-slots. Hence, although the frame contains a fixed number of digit time-slots, it does not necessarily contain a fixed number of information bits from the tributaries. By this means, variations in tributary bit rates can be accommodated.

### FRAME STRUCTURES AND PERFORMANCE CONSIDERATIONS

The formulation of the frame structures used in the digital multiplex hierarchy enables the operation of each stage of multiplexing to be independent of any signals or information contained in the lower-order digital inputs to be multiplexed.

† Plesiochronous—Two signals are plesiochronous if their corresponding significant instants occur at nominally the same rate, any variation in rate being constrained within specified limits

\* Justification—A process of changing the rate of a digital signal in a controlled manner so that it can accord with a rate different from its own inherent rate, usually without loss of information

TABLE 1  
Frame Structures

Multiplexed digit rate (Mbit/s)	8·448 (Note 1)	120	34·368 (Note 2)	139·264 (Note 2)
Number of tributaries	4	14	4	4
Tributary bit rate (Mbit/s)	2·048	8·448	8·448	34·368
Sequence of digits:				
Frame-alignment-signal digits	10	12	10	12
Service digits	2	2	2	4
Digits from tributaries (digit interleaved)	200	1064	372	472
First digits for justification-control signals	4	14	4	4
Digits from tributaries	208	1064	380	484
Second digits for justification-control signals	4	14	4	} 4+484 sequence repeated 3 times
Digits from tributaries	208	1064	380	
Third or fifth digits for justification-control signals	4	14	4	
Justifiable digits, one per tributary	4	14	4	4
Digits from tributaries	204	1050	376	480
Total digits in frame	848	4312	1536	2928
Frame repetition rate (frames/ms)	9·96	27·83	22·375	47·56

Note 1: CCITT Recommendation G 742 (Table 1)

Note 2: CEPT approved structures expected to be recommended by CCITT

To achieve this, all the extra digits required for frame-alignment and justification-control purposes are included in the frame structures for each stage of multiplexing as already described.

The frame structure used by the 2 Mbit/s to 8 Mbit/s multiplex equipment (a photograph of 2 of which is shown in Fig. 2) conforms to CCITT Recommendation G742 (Table 1), which incorporates a bunched frame-alignment signal and uses positive justification with 3 control digits per tributary. The 8 Mbit/s to 120 Mbit/s multiplex uses a frame structure particular to the UK, since 120 Mbit/s is a non-standard rate internationally; the structure, however, has a similar form. Table 1 gives details of frame structures based on the 2·048 Mbit/s primary rate. The first 2 columns in Table 1 give the structures used to multiplex from the primary rate to 120 Mbit/s, providing a capacity of 1680 telephone channels.

### Frame Alignment

The strategy used to acquire frame alignment with any of the above structures is for the demultiplex to search for and recognize the frame-alignment signal, lock its timing counters into the correct phase relationship with the incoming signal, and then examine the frame-alignment signal in 2 successive confirmatory frames. Non-recognition of the signal in its expected position in either of these 2 frames causes a recommitment of the search.

The minimum time that is necessary to acquire and confirm frame alignment is, therefore, between 2 and 3 frame periods, depending on the point within the frame that a valid signal is applied and the search commences. However, the incoming signal contains an essentially random occurrence of ones and zeros in the information digit time-slots, and there is a probability of these digits imitating the frame-alignment signal. The probability of an imitation in any position is  $2^{-m}$  for a random digit stream,  $m$  being the number of digits in the frame-alignment signal. In practice, a shift register having  $m$  stages, and stepped at the incoming digit rate, is used to detect the position of the frame-alignment signal. The contents are examined at every step; therefore, the search can contain,

for example, up to 847 steps in the case of the 2 Mbit/s to 8 Mbit/s multiplex. Due to the composition of the frame-alignment signal (1111010000), not all the steps have a probability of containing this code, a feature of this particular code, and those used for the other multiplexes, being that it cannot be repeated within itself by adding on any combination of digits. For example, if the code 1010101010 were used, the addition of 2 extra digits, 10, would imitate the correct code displaced by 2 digit time-slots.

If a shorter code were used, more erroneous frame-alignment signals would be detected during the search and the time required to acquire frame alignment would increase due to the greater number of false starts, the false alignment being rejected at the first or second confirmatory frame. The time,  $t$ , to acquire frame alignment with a 99% probability of not being exceeded can be estimated using the following simplified formula<sup>1</sup> for an alignment strategy requiring 2 confirmatory frames and assuming an imitation can occur at any step:

$$t = \frac{F}{M} \{3 \cdot (F-1)2^{-m} + 2 \cdot 3[(F-1)2^{-m}]^{0.5}\} \text{ seconds,}$$

where  $F$  is the total number of digits in the frame of the multiplexed signal,

$M$  is the multiplexed signal rate (bits/second), and

$m$  is the number of digits in the frame-alignment signal.

With any of the above structures, frame alignment is considered to have been lost when 4 consecutive frame-alignment signals are incorrectly received in their predicted positions. The probability of random digital errors causing this condition to be fulfilled is approximately  $(mp)^4$  when  $p$ , the signal error rate, is low; better than, say, 1 in  $10^3$ . It follows that the mean time between losses of frame alignment

for a given error rate is  $\frac{F}{M(mp)^4}$  seconds.

The mean time between losses of frame alignment for error rates of better than 1 in  $10^4$  works out to be in the order of years; an error rate of 1 in  $10^4$  is probably the worst acceptable under fault conditions before a system is taken out of service.

### Justification

In multiplexes using positive justification, such as those given in Table 1, the transmission capacity provided for each tributary input in the non-justified condition is equal to the maximum acceptable rate at which information may be presented to the input, as all the justifiable digit time-slots associated with that tributary then carry information. To synchronize the multiplex with a lower incoming tributary signal rate, the associated justifiable digit time-slots in some frames carry non-information or justification digits; the lower the input rate, the greater is the number of frames carrying justification digits in this time slot until, at the lowest acceptable input rate, all frames carry justification digits.

The average rate at which a justifiable digit time-slot carries non-information digits is called the justification rate, and is equal to the difference between the maximum rate the multiplex input port can accept and the incoming tributary signal rate. The justification rate is therefore

$$\frac{F'M}{Fn} - T \text{ bits/second,}$$

where  $M$  is the multiplexed signal rate (bits/second),

$F$  is the total number of digits in the frame,

$F'$  is the number of digits in the frame available to carry information,

$n$  is the number of tributary inputs, and

$T$  is the tributary input signal rate (bits/second).

In a multiplex using positive justification,  $\frac{F'M}{Fn}$  must be

greater than  $T$  when the multiplexed signal rate tolerance and the tributary signal rate tolerance are in their most adverse directions. Since one justifiable digit time-slot is provided in each frame for each tributary signal, the maximum justification rate is the same as the frame rate,  $M/F$ . The ratio,  $g$ , of the justification rate to the maximum justification rate has a significance when considering the low-frequency phase jitter<sup>†</sup> produced by the justification process, as will be shown later. The value of  $g$  is given by

$$g = \left( \frac{F'M}{Fn} - T \right) / \frac{M}{F} \text{ which reduces to } \frac{F'}{n} - \frac{FT}{M}.$$

The value of  $g$  can vary between 0, when all the justifiable digit time-slots carry information, and 1, when none of them does so. In practice, there are advantages in restricting  $g$  to a small range of values, which means the range of justification control provided is much greater than that required to accommodate the digit-rate tolerances.

In the 2 Mbit/s to 8 Mbit/s and the 8 Mbit/s to 120 Mbit/s multiplexes, 3 control digits are provided per tributary input to indicate to the distant demultiplex whether the justifiable digit time-slot in that frame carries information or can be ignored. To give protection against burst errors, the 3 control digits associated with a particular tributary are distributed within the frame. All 3 justification-control digits are sent as ones when the justifiable digit time-slot carries no information, and zeros when it does. The triplication of the control digits enables a majority decision at the demultiplex; hence, 2 digital errors are required in the control signal to cause a justification error. Protection against errors in the justification-control signals is important, since a justification error causes either a digit to be omitted from the output stream or an additional digit to be inserted. In both cases, the resulting one digit slip at the output causes all the dependent systems to lose frame alignment. The probability of a justification error caused by random signal errors is approximately  $3p^2$ , for multiplexes using 3 control digits and, when  $p$  has a low value, the mean time between justification errors or slips is  $\frac{F}{3Mp^2}$  seconds.

TABLE 2  
Values of Parameters for Multiplexing from  
2 Mbit/s to 120 Mbit/s

Multiplexed digit rate (Mbit/s)	8.448	120	
Time to acquire frame alignment with a 99% probability ( $\mu$ s)	596	232	
Mean time between losses of frame alignment at digital error rates of	$\begin{cases} 1 \text{ in } 10^4 \\ 1 \text{ in } 10^5 \end{cases}$	$\begin{cases} 3.2 \text{ years} \\ \text{Very large} \end{cases}$	$\begin{cases} 0.55 \text{ year} \\ \text{Very large} \end{cases}$
Justification rate per tributary at nominal signal rates (kbit/s)	4.23	12.11	
Justification ratio, $g$ , at nominal signal rates	0.424	0.435	
Mean time between justification slips at digital error rates of	$\begin{cases} 1 \text{ in } 10^4 \\ 1 \text{ in } 10^5 \\ 1 \text{ in } 10^6 \end{cases}$	$\begin{cases} 59 \text{ min} \\ 93 \text{ h} \\ 1.06 \text{ years} \end{cases}$	$\begin{cases} 20 \text{ min} \\ 33 \text{ h} \\ 0.38 \text{ year} \end{cases}$

Table 2 gives the calculated values of the foregoing parameters, concerning frame alignment and justification, for the 2 frame structures used to multiplex the 2 Mbit/s inputs to 120 Mbit/s. At higher error rates, the limiting performance factor is the justification slips at the 8 Mbit/s input.

<sup>†</sup> Jitter—Short-term variations of the significant instants of a digital signal from their ideal positions in time

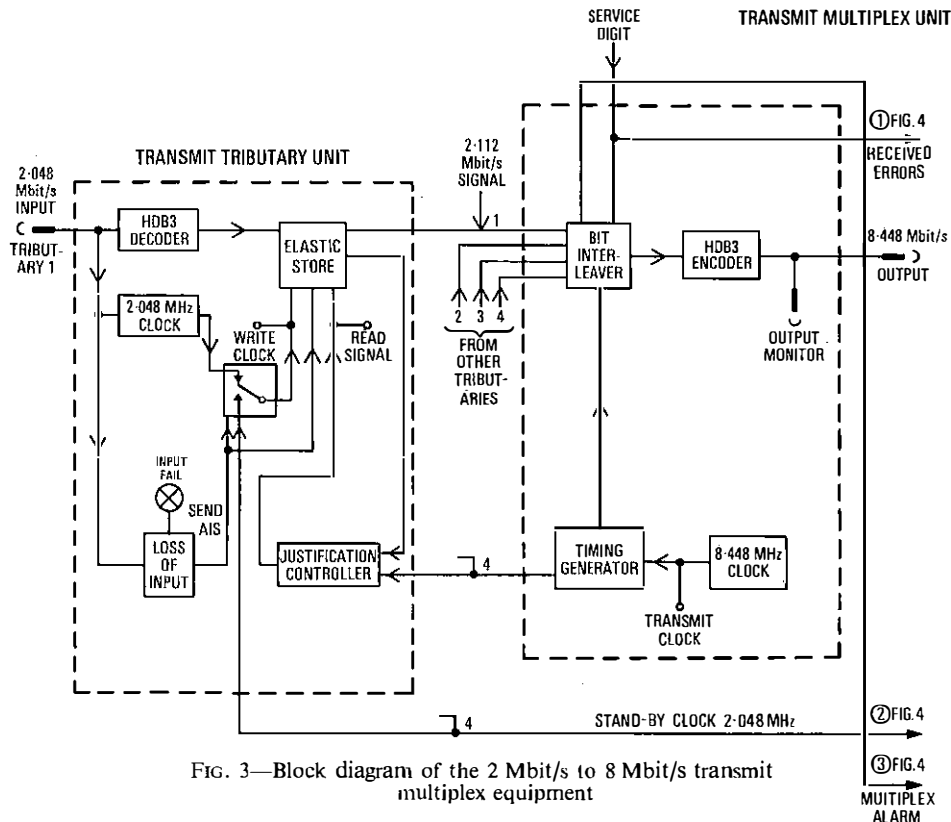

FIG. 3—Block diagram of the 2 Mbit/s to 8 Mbit/s transmit multiplex equipment

## CIRCUIT TECHNIQUES

### Overall Operation of Multiplex Equipment

The main functions contained within the 2 Mbit/s to 8 Mbit/s multiplex equipment are illustrated in Figs. 3 and 4; similar functions also occur in the 8 Mbit/s to 120 Mbit/s multiplex equipment.

The operation of the signal path is as follows. Each of the 4 inputs at 2.048 Mbit/s is applied to an identical transmit tributary unit. The transmit tributary units decode the HDB3† coded input into a binary signal and recover the clock timing of the input signal, which is then used to read the binary information into the input elastic store. The store output is read by a multiplex-derived timing signal at an instantaneous rate of 2.112 Mbit/s, with gaps where non-information bits occur in the frame. The outputs from the tributary units, at 2.112 Mbit/s, contain the appropriate justification-control code and justification digits. The frame-alignment-signal digits are written into their appropriate digit time-slots in the common transmit multiplex unit, enabling the multiplex equipment to function on the remaining paths if a tributary unit is removed for maintenance purposes.

The common transmit multiplex unit bit-interleaves the 4 synchronous 2.112 Mbit/s signals, one from each tributary unit, to produce an 8.448 Mbit/s output which is then encoded into HDB3. Common timing signals are distributed to the 4 transmit tributary units to define the multiplex clock rate, and the position of the frame-alignment signal, the justification-control signal and the justifiable digit time-slots, thus enabling the tributary units to deliver these signals to the common transmit multiplex unit in identical phase.

At the receive terminal (Fig. 4), the 8.448 Mbit/s input signal to the receive multiplex unit is decoded from HDB3 into a binary signal, and the clock timing of the input signal is recovered to control the timing of the demultiplexing operations. The frame-alignment signal is detected to enable the four 2.112 Mbit/s signals to be bit-dis-interleaved and distributed

to their respective receive tributary units. As in the transmit multiplex, common timing signals are distributed to the receive tributary units to indicate the position of the justifiable digit time-slot, the justification-control digits and the frame-alignment signal.

Each of the 4 receive tributary units contains a justification-code detector which enables the contents of the justifiable digit time-slot to be determined; only information digits are read into the elastic store, the justification-control and frame-alignment digits are also discarded at this stage. A phase-locked oscillator is used to read the output from the elastic store, its reference being derived from the 2.112 Mbit/s store write signal. This has pulses only in positions corresponding to the information digits, and therefore has an average rate equal to that of the corresponding distant tributary input signal. The 2.048 Mbit/s retimed output signal is encoded into HDB3.

The tributary units can be regarded as performing the function of input synchronization and output desynchronization, to a rate of  $1/n$  times the multiplex signal rate,  $n$  being the number of tributary inputs, leaving a purely synchronous multiplex operation to the common units.

### Elastic Store

The average justification rate, required to adjust the input rate of the multiplex equipment to the tributary signal rate, has been considered. However, over a short period, the multiplex signal rate can be higher than the input signal rate since correction occurs only at discrete intervals, and the resulting phase variations have to be accommodated in an input store. A similar requirement exists at the demultiplex outputs; the information digits at the multiplex signal rate, with gaps where frame-alignment, justification-control and justification digits have been discarded, are retimed to produce evenly-spaced signal intervals at a rate corresponding to that of the tributary input signal at the distant multiplex.

These requirements are met by the use of elastic stores of the kind illustrated in Fig. 5(a); for convenience, the rates illustrated apply to the 2 Mbit/s to 8 Mbit/s multiplex, but similar principles apply at other rates. The incoming

† HDB $n$  is a class of highly-redundant ternary codes in which  $n$  is the number of permissible consecutive zeros

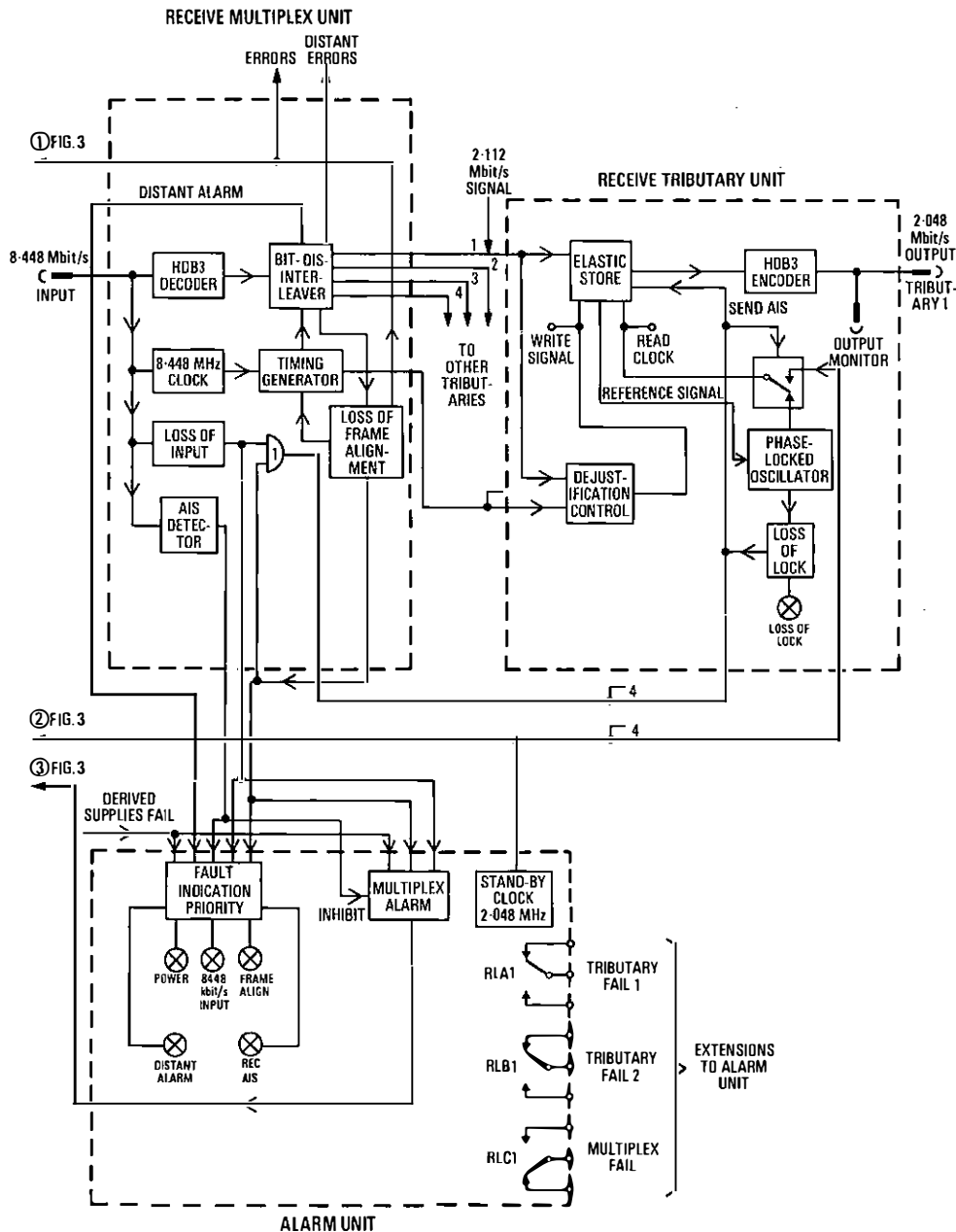

Fig. 4—Block diagram of the 2 Mbit/s to 8 Mbit/s receive multiplex equipment

signal is presented to stores A–H, and the counter distributor, driven by the 2.048 Mbit/s clock signal derived from the incoming tributary signal, writes a digit into each store in sequence. The store outputs are applied to 8 AND gates, all paralleled at the signal output. These gates are enabled, in sequence, by the read distributor driven from the 2.112 Mbit/s multiplex-derived clock signal, which has pulses omitted in positions corresponding to the frame-alignment, justification-control and justification digits. The timing diagram in Fig. 5(b) shows that each storage stage stores every eighth digit. Each store can be read at any time during the intervening 8 digit periods, a suitable margin being left at the beginning and end of this time to allow for finite write and read times. The store fill at any instant can be determined by the relative phase of the write and read distributors, and the fill detector shown would give an indication when only 2 digits are left in the store.

A diagram showing the variation in the input-store fill over one frame period of the 2 Mbit/s to 8 Mbit/s multiplex is shown in Fig. 6. This diagram could apply to either a tributary input or output store; in the latter case, the diagram

would show the demultiplex write time relative to the read clock, and a phase advance would increase the store fill instead of reducing it. Thus, it is evident that the total number of digits held in both input and output stores tends to be constant, and the overall system delay is therefore constant if jitter effects are ignored.

At the beginning of a frame period in Fig. 6, the read clock retards 3 digit periods relative to the 2.048 Mbit/s write clock, during the frame-alignment-signal time, as 3 read pulses are missed at the 2.112 Mbit/s rate. The read clock then advances through the remainder of the first quarter frame period at a rate of  $\frac{M}{n} - T$  bits/second. At the first justification-control-digit time, another read clock pulse is missed and the read clock retards another digit period; it then advances through the remainder of the quarter frame period as before. Over a complete frame period, the total advance of the read clock is

$$\left(\frac{M}{n} - T\right) \frac{F}{M} \text{ digit periods.}$$

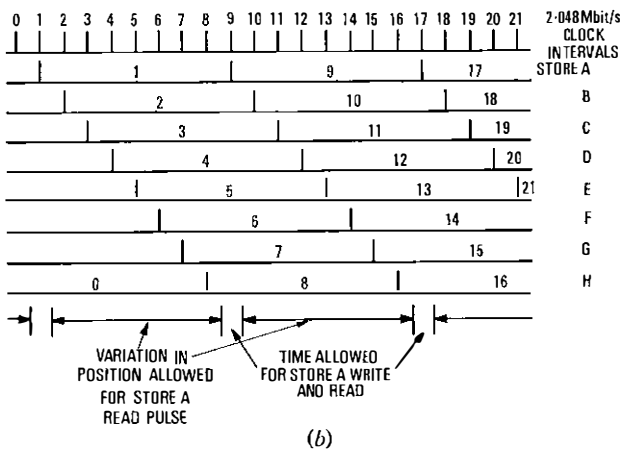
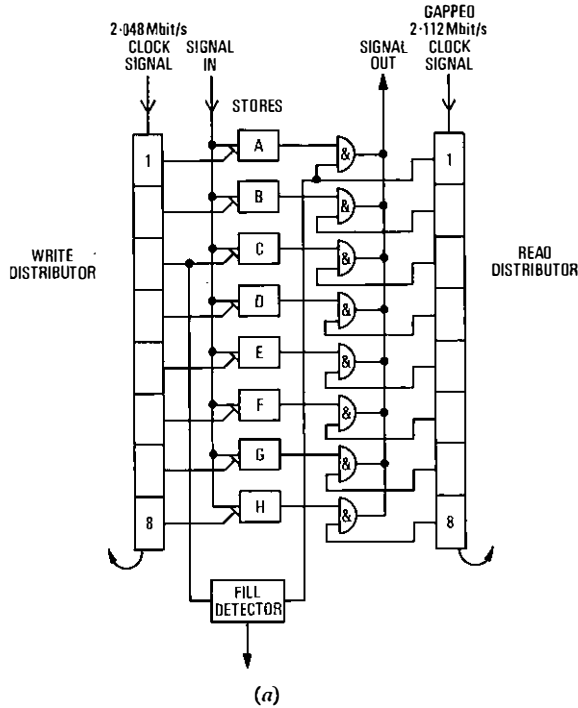

FIG. 5—The 8-digit elastic store circuit and timing diagram

The total retardation over a frame period is

$$\frac{F - F'}{n} \text{ digit periods in a non-justified frame, and}$$

$$\frac{F - F'}{n} + 1 \text{ digit periods in a justified frame.}$$

The net advance over a non-justified frame is therefore

$$\left(\frac{M}{n} - T\right) \frac{F}{M} - \frac{F - F'}{n} \text{ digit period.}$$

This reduces to  $\frac{F'}{n} - \frac{FT}{M}$ , which equals  $g$  digit period.

The advance of the read clock with respect to the write clock during a justified frame is 1 digit period less as an extra read pulse is missed at the justifiable digit time-slot.

During the frame shown, although the net advance of the read clock is only  $g$  digit period in a non-justified frame, the total phase excursion is  $3 + g$  digit periods peak-to-peak. In addition to meeting this requirement, storage must be allocated for the input-signal jitter and finite store write and read times; in practice, an 8 bit store is commonly used.

### Phase-Locked Oscillator

To retune a tributary output signal, a circuit of the kind shown in Fig. 7 is used to derive the evenly-timed clock signal re-

quired. The reference signal used is the demultiplex timing signal that writes the information digits into the elastic store, and the divider function shown is provided by the store write distributor. This timing signal has an average rate equal to that of the tributary input signal at the distant multiplex, since it is gated by the output of the justification-control-digit detector and also has pulses removed at the frame-alignment and justification-control-digit positions. A crystal-controlled oscillator is used, the frequency being controlled over a small range by a variable-capacitance diode. The output of the oscillator drives the elastic-store read distributor, which also provides the divider function. The divided reference and oscillator signals are applied to a phase comparator which can detect a phase difference of up to  $\pm 4$  digit time-slots at the tributary rate; the filtered output voltage controls the variable-capacitance diode, thus completing the loop.

Any frequency difference between the crystal oscillator and the reference produces an output voltage from the phase detector that varies the frequency of the crystal-controlled oscillator to bring it into lock with the reference, provided the initial frequency difference is within the pull-in range of the loop. The phase-locked loop stabilizes at a constant phase relative to the reference signal, dependent on the loop gain, which is known as the *error* phase angle. The low-pass filter reduces the control-loop bandwidth and thus increases the response time to a change in phase of the reference signal; rapid fluctuations in the phase of the reference are not followed, and the loop phase assumes a mean value relative to the changing reference. Thus, the characteristics of the phase-locked oscillator in conjunction with the tributary output store provide a reduction in jitter, both for jitter generated in the multiplex equipment and also for phase jitter on an input signal to the multiplex that is transferred to the output store by the justification process. Jitter occurring in the transmission path between the multiplex and demultiplex is also reduced.

Fig. 8 illustrates the jitter transfer characteristic of a tributary path, determined by the phase-locked oscillator jitter-attenuation characteristic, relative to the main jitter components present in the phase-locked oscillator reference signal.

Characteristics of the phase-locked oscillator circuit that must be specified are

- (a) the 3 dB jitter bandwidth, defined as the frequency of a sine-wave phase modulation of the reference input that is attenuated by 3 dB,
- (b) the maximum jitter gain within the passband, defined using a sine-wave phase modulation of the reference input,
- (c) the settling time after the application of the reference signal, and
- (d) the pull-in frequency range, which must be sufficient to allow for the input signal-rate tolerance.

These requirements have been suitably fulfilled using a highly-damped loop design to obtain a negligible jitter gain within the passband. Typical jitter bandwidths achieved are 30-40 Hz, while obtaining settling times of about 30 ms. The pull-in range is usually limited by the amount the crystal-controlled oscillator frequency can be pulled.

### WAITING-TIME JITTER

The decision to send a justification digit in the justifiable digit time-slot associated with a tributary signal input is made at a fixed point in each frame, to avoid the decision being affected by the repetitive variations in store fill that occur within the frame. A point during the first quarter-frame period is normally used to permit the correct justification code to be sent prior to the justifiable digit time-slot.

●wing to the decisions being made at fixed time intervals, the input-store fill often reduces beyond the decision threshold before being sampled. The time delay between the



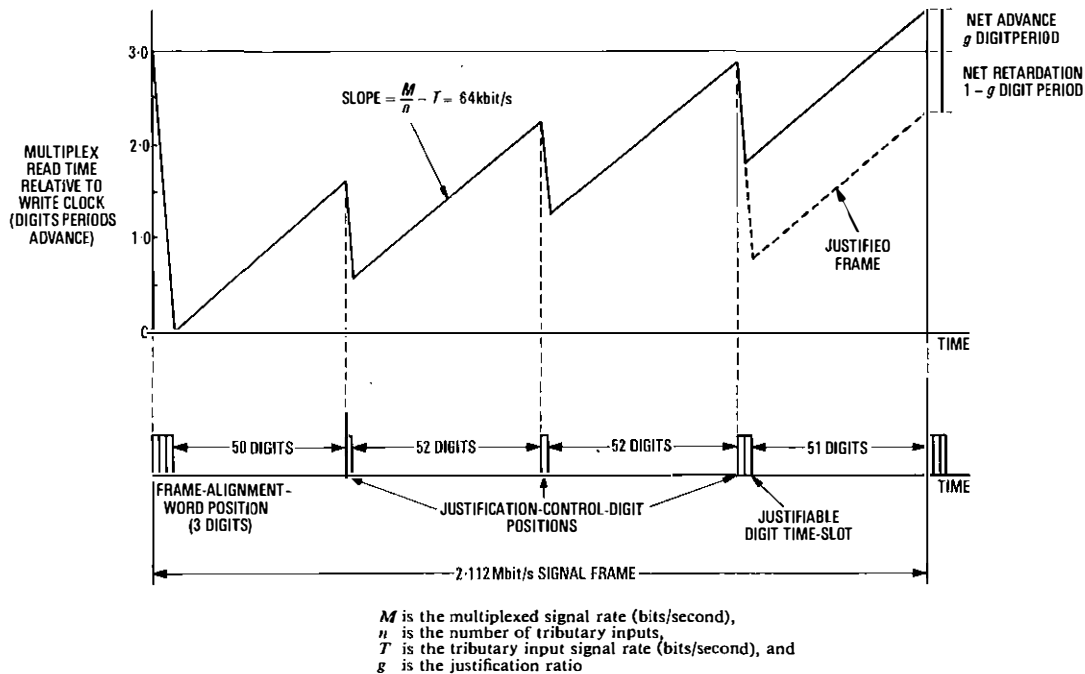

FIG. 6—Variation of input-store fill for one frame of 2 Mbit/s to 8 Mbit/s multiplex

store fill reducing beyond the threshold and being sampled is known as the *waiting-time delay*, and its value is variable from frame to frame. Resulting from this delay, there is a phase overswing in the store read time relative to the write clock, which is also variable from frame to frame, and results in a phase variation called *waiting-time jitter*. Identical jitter occurs at the associated tributary output, because the justification-control signal causes the tributary output-store write clock to follow phase in sympathy; it must do this or digital slips occur.

Waiting-time jitter has a low-frequency component when the justification ratio,  $g$ , is at or near an integer ratio, and the amplitude of the low-frequency component in digit periods is the reciprocal of the denominator of this ratio. This component can be low enough in frequency to phase modulate the phase-locked oscillator loop and hence produce a low-frequency jitter on the output signal timing. In the multiplex frame structures used, careful choice of the range of  $g$  limits the output jitter amplitude. Referring to the 2 Mbit/s to 8 Mbit/s multiplex, the range of  $g$  used is 0.4078–0.4406, allowing a tolerance of  $\pm 50$  parts/million for the 2.048 Mbit/s input and a tolerance of  $\pm 30$  parts/million for the 8.448 Mbit/s output. The ratio of integers that has the lowest denominator occurring within this range is  $3/7 \approx 0.4286$ .

A more complete treatment of this subject is given elsewhere<sup>2</sup>, but a simplified graphical explanation follows to convey the nature of waiting-time jitter. Referring to Fig. 9, the phase advance or retardation of the input-store read clock, shown only at the justification decision times, is traced. The plot starts with a decision to justify having just been made, with the store read clock exactly at the justification decision threshold. Previously, it was shown that the phase advance over a non-justified frame was  $g$  digit period, and over a justified frame was  $g - 1$  digit period; therefore, the slope of the line during the first frame period is  $g - 1$  digit period per frame. The slope during the second frame, which is non-justified, is  $g$  digit period per frame, and the plot continues in this manner revealing a repetitive pattern 7 frames long, when  $g = 3/7$ . Every seventh frame requires a decision when the fill is exactly at the threshold of the detector; the result can go either way in an arbitrary manner, due perhaps to circuit noise, and a change in the 7 frame long sequence can occur at this time. The variation in the magnitude of the phase overswing is shown by the dotted line which, by the earlier

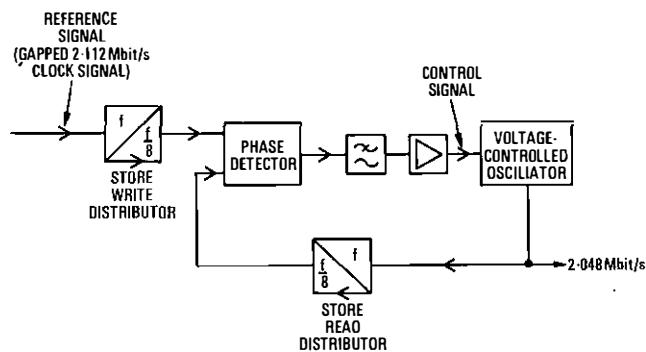

FIG. 7—Block diagram of phase-locked oscillator

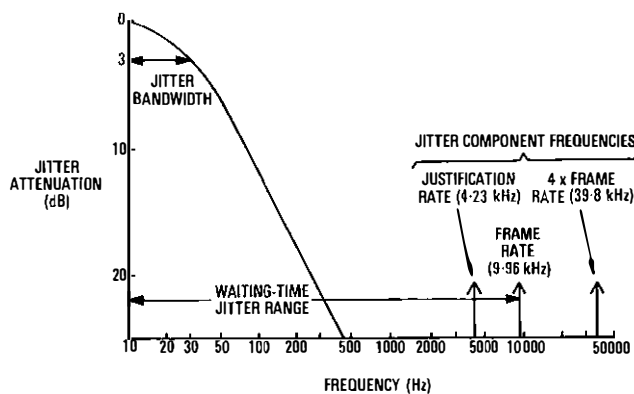

FIG. 8—Jitter transfer characteristic of 2 Mbit/s to 8 Mbit/s multiplex

definition, also represents the waiting-time jitter. It can be seen that an extra  $1/7$  digit period overswing occurs when the pattern changes and this represents a non-repetitive component of the waiting-time jitter; the total waiting-time jitter amplitude is  $3/7$  digit period.

If the justification ratio  $g$  is exactly  $3/7$ , the store counters could remain in the phase shown, where every seventh decision is critical, but if the ratio is almost  $3/7$ , the pattern changes occur at a low rate and in a cyclic manner as the

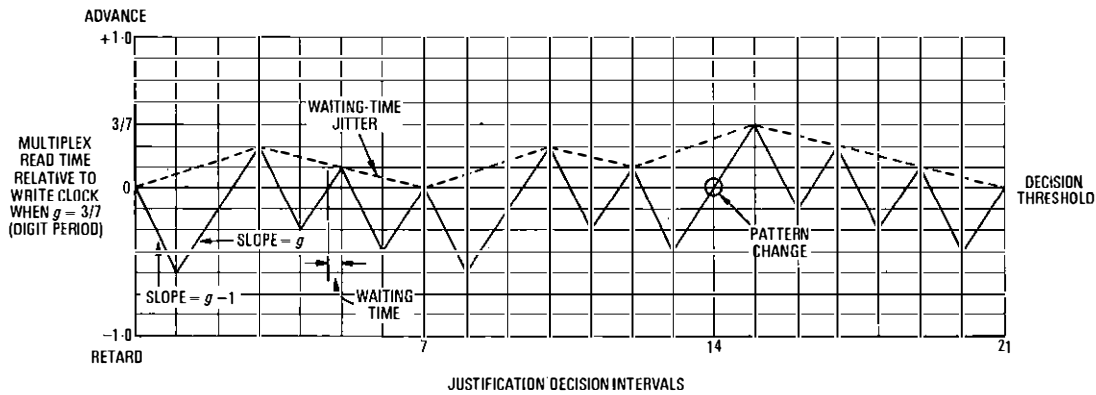

FIG. 9—Graphical illustration of waiting-time jitter

pattern drifts through each  $1/7$  digit period. The amplitude of the low-frequency jitter component has the characteristics of a low-frequency beat as the signal input is varied through the rate giving a justification ratio of  $3/7$ .

To cater for waiting-time jitter, the present multiplex specifications allow  $0.15$  digit period peak-to-peak low-frequency jitter at the lower-rate outputs; the higher jitter frequencies resulting from the justification process are all filtered and reduced in amplitude by the phase-locked oscillator circuit.

Jitter on an incoming tributary signal instantaneously varies the value of  $g$ , due to the resulting deviations in the input rate, and this has the effect of reducing the jitter peaks at the integer ratios. The jitter allowance specified is therefore a worst-case limit for jitter produced by a multiplex.

Low-frequency jitter, however, accumulates in a digital system, as it is not attenuated by jitter-reducing circuits and is removed only at an independently-timed function such as a digital switch. Here, the overall effect of jitter on the exchange-clock synchronization system must be considered. Jitter affects a decoded analogue signal causing phase modulation of the decoded samples, but distortion is normally negligible for telephony signals sampled at a rate of  $8\text{ kHz}$ .

### ALARM FACILITIES AND FAULT INDICATIONS

The alarm strategy chosen is such that, from the point of entry through to the point of exit at a level in the multiplex hierarchy, the signal is continuously monitored for its presence and validity. The alarm circuits are divided into 2 categories: tributary alarms, which are initiated by faults originating at the lower-bit-rate input and output ports of the multiplex equipment, and the multiplex alarm, which monitors faults occurring in the higher-bit-rate input to the demultiplex equipment.

The tributary alarms are further divided between 2 circuits, with part of the alarm circuitry contained within the tributary units (see Figs. 3 and 4). One alarm circuit monitors the presence of tributary input signals and, upon receipt of more than a given number of consecutive HDB3 signal zeros, initiates an INPUT FAIL alarm. The second tributary alarm circuit, designated LOSS OF LOCK, monitors the state of the phase-locked oscillator which controls the receive tributary output signal rate. An alarm is initiated when an oscillator runs at a rate that is not controlled by the transmit tributary input signal. This condition can occur because of a tributary input signal that is considerably outside the bit-rate tolerance limits, a fault in the justification process, or a fault in the phase-locked-loop circuit.

The multiplex alarm circuit is activated by one or more of the following conditions:

- (a) a power unit failure,
- (b) loss of the high-bit-rate input signal, activated upon

receipt of more than a given number of consecutive HDB3 signal zeros, and

(c) loss of frame alignment with the incoming high-bit-rate input signal.

The relays, RLA, RLB and RLC, in Fig. 4, extend the 2 tributary and the multiplex alarm circuits to individual inputs of an external alarm panel, which provides centralized receiving-attention facilities and access to the station alarms. Visual fault indications are provided to enable the fault condition causing an alarm to be identified. A priority, dependent on the nature of the fault, is assigned to the fault indications so that only one indication per fault is given. Faults that cause dependent secondary indications to be given are assigned a higher priority, the lower priority indication in the same direction of transmission being suppressed. Table 3 shows the priority of each indication, using the  $2\text{ Mbit/s}$  to  $8\text{ Mbit/s}$  multiplex as an example.

TABLE 3  
Example of Fault Indications and Priorities

Fault	Indication	Priority
Power unit failure	POWER	1
Loss of incoming $2.048\text{ Mbit/s}$ signal (transmit direction) Loss of incoming $8.448\text{ Mbit/s}$ signal (receive direction)	INPUT FAIL 8448 kbit/s INPUT	2
Loss of frame alignment (receive direction) Receipt of $8.448\text{ Mbit/s}$ alarm-indication signal (receive direction)	FRAME ALIGN REC AIS	3
Loss of lock of tributary timing oscillator (receive direction) Receipt of distant alarm signal via a service digit (receive direction)	LOSS OF LOCK DISTANT ALARM	4

An additional facility is provided whereby the existence of a multiplex alarm condition at a distant terminal is signalled back to the originating terminal by the use of one of the service digits in the return transmission path.

### Alarm-Indication Signal

In accordance with the overall alarm philosophy, an alarm should be raised only at the point of failure or the next point at which the fault can be detected. To prevent the operation of a large number of unnecessary alarms at a multiplicity of points further down in the hierarchy and at succeeding repeater stations, a method of suppressing these alarms is provided in the form of an alarm-indication signal (AIS).

The AIS is a discrete binary sequence, the recognition of which can be used to inhibit the operation of station alarms beyond the point of its generation. The binary sequence chosen

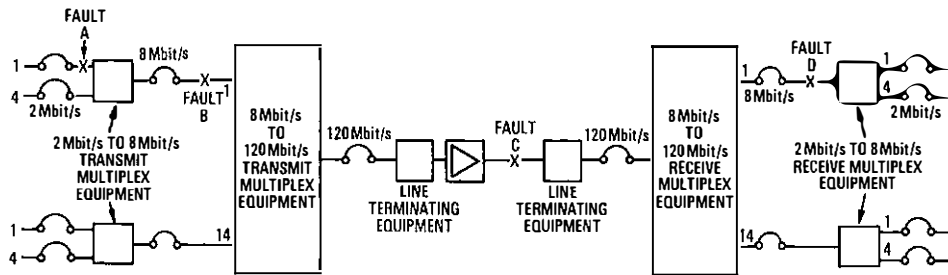

FIG. 10—Fault indications and generation of the alarm-indication signal

TABLE 4  
Fault Indications and Generation of the Alarm-Indication Signal

Fault (See Fig. 10)	2 Mbit/s to 8 Mbit/s Transmit Multiplex			8 Mbit/s to 120 Mbit/s Transmit Multiplex			8 Mbit/s to 120 Mbit/s Receive Multiplex			2 Mbit/s to 8 Mbit/s Receive Multiplex			Signal Forward at 2 Mbit/s
	Indica- tion Given	Station Alarm	AIS Genera- tion	Indica- tion Given	Station Alarm	AIS Genera- tion	Indica- tion Given	Station Alarm	AIS Genera- tion	Indica- tion Given	Station Alarm	Ats Genera- tion	
A Loss of 2 Mbit/s Input	INPUT FAIL	Yes	At tributary input	None	None	None	None	None	None	None	None	None	AIS at one output
B Loss of 8 Mbit/s Input	—	—	—	INPUT FAIL	Yes	At tributary input	None	None	None	FRAME ALIGN and REC AIS	None	At tributary outputs	AIS at 4 outputs
C Loss of 120 Mbit/s Input	—	—	—	—	—	—	120 Mbit/s INPUT FAIL	Yes	At tributary outputs	FRAME ALIGN and REC AIS	None	At tributary outputs	AIS at all outputs
D Loss of 8 Mbit/s Input	—	—	—	—	—	—	—	—	—	8448 kbit/s INPUT FAIL	Yes	At tributary outputs	AIS at 4 outputs

AIS—alarm-indication signal

for the AIS is "all ones", which conforms with CCITT proposals. The loss of frame-alignment indications operate normally when the AIS is received and indications of receipt of AIS are also given, but the station alarms are suppressed. Fig. 10 and Table 4 together show the points of AIS generation and fault indications given when the signal is lost at various points in a network. Figs. 3 and 4 show the methods of AIS generation in a complete equipment. The signal rate of the AIS generated at the tributaries is controlled by an internal stand-by oscillator. When generated at the input to a tributary, during loss of input conditions, the AIS is treated as a normal signal by the remaining part of the multiplex; it thus undergoes the process of justification and allows the corresponding receive tributary to maintain correct timing. For loss of lock, loss of high-bit-rate input and loss of frame alignment conditions, the AIS is generated, under the control of the stand-by oscillator, at the output of the tributaries concerned. For a power unit failure, the AIS cannot be generated at the affected equipment, but it is generated by the next equipment, which has the capability of recognizing the loss of an input signal.

#### ERROR-RATE MONITORING

In-service error-rate monitoring of an overall link can be performed at each level in the multiplex hierarchy by use of the frame-alignment signal. Since the frame-alignment signal

for each level of the hierarchy is a discrete code and is always present in a valid signal, it provides a means of obtaining an indication of the binary error rate. At present, the frame-alignment signals are monitored at their associated receive multiplex equipments, but by using separate test apparatus, the frame-alignment signal of a particular hierarchical level could be monitored, wherever that level appears in a tandem-connected system. This can be accomplished using the digital monitor points at the outputs of digital line systems and multiplex equipments. To give a good discrimination against the probability of the count being fulfilled by lower error rates and hence to improve accuracy, determination of error rates should be based on a count of at least 10 errors. The method of error detection employed in the multiplex makes use of the circuit which detects incorrect frame alignment and produces one output pulse per incorrect frame-alignment signal, irrespective of whether one or more bits are incorrect in the block; this prevents burst errors from giving an untypically high reading. The monitoring circuit provides an output pulse, one frame period long, at a front-panel output socket, to which an external counter can be connected. The method has certain disadvantages: firstly, to measure an error rate of 1 in  $10^6$  at 8.448 Mbit/s takes approximately 100 s due to the small sample of the signal being examined, with lower error rates taking a longer period; secondly, errors occurring in groups, due to error extension produced

by coding-decoding processes in the digital path, are not measured individually; thirdly, pattern-dependent errors arising from transmission impairments within a digital line section can give a misleading measurement.

Although providing only an approximate indication of the true binary error rate, this method can be used as a first-line maintenance aid to localize faults causing high error rates and has the advantage of measuring the total error rate of the digital path up to the point of measurement. Successive measurements can be made at each level in the multiplex hierarchy, and at each station, until the cause of the errors is located. If greater accuracy of error-rate measurement is required, this must be undertaken out-of-service using a pattern generator and error detector, which gives a bit-by-bit comparison of the received signal with the transmitted pattern.

An additional facility is provided in the multiplex whereby one station can monitor the error rate of both the received incoming signal and the outgoing signal as received by the distant station. This is achieved by using the output of the frame-alignment-signal error detector in the receive multiplex to modulate a service digit time-slot in 2 successive frames in the return direction of transmission. Two successive service digit time-slots are used to provide protection against additional errors being introduced in the return path, since at the receive terminal, 2 successive ones must be received to give one error pulse at an output socket.

### MAINTENANCE FACILITIES

Protected test points are provided to enable a rapid check to be made of certain major internal functions of the multiplex. The outputs provided have waveforms that are suitable for connecting to a frequency counter, which is regarded as the main first-line maintenance tool. An example of how a counter can be used to give a simple maintenance indication of a complex function is that of the justification and dejustification process; this can be checked by ensuring that the frequency of the signal at a pair of tributary store read and write test points is the same when measured over a short specified period. By using a frequency counter, it is envisaged that a fault can be localized to one card and then, by card substitution, the fault can be cleared.

### SERVICE PROTECTION FACILITIES

A service protection network, which is provided for the 4 MHz and 12 MHz FDM systems, will not initially be provided for the 120 Mbit/s digital systems. The 8 Mbit/s to 120 Mbit/s multiplex does, however, have high-bit-rate dual outputs and switched 120 Mbit/s inputs, providing facilities such that in-service switching to a spare line system, in the event of a line system failure between 2 multiplexes, is still possible. The 120 Mbit/s input switch can be controlled from the same broadband switching equipment as is used with FDM systems, although changes to the signal-path facilities will be required.

### MECHANICAL ARRANGEMENT

The photographs in Figs. 1 and 2 show the mechanical layout of the field-trial equipments. It can be seen that, as far as

possible, a complete function is contained within one unit, and this policy is adopted throughout all levels of the multiplex hierarchy. The 120 Mbit/s equipment occupies nominally 4 shelves, catering for card units and access panel, with an additional 2 shelves, each of one-third normal shelf height, being used for ventilation. A large amount of heat is generated by the high-speed logic used in the 120 Mbit/s transmit and receive multiplex units, and much thought has been given to the design and layout of the equipment to ensure an efficient airflow through these units.

To reduce the overall heat dissipation on production equipments, it is expected that low-power Schottky logic circuits will be used where possible in the low-speed tributary units, up to and including 8 Mbit/s. The use of low-power Schottky logic circuits would give the additional benefit of reducing the power consumption.

The test-access link panel, fitted to the development equipments, will not be fitted to production equipments, as break-link access will be available at the 2 Mbit/s and 8 Mbit/s digital distribution frames. Coaxial test links will still be provided at the 120 Mbit/s inputs and outputs, as a digital distribution frame will not be provided at this level.

### CONCLUSIONS

The stages of multiplexing required to multiplex from the 2.048 Mbit/s primary rate to 120 Mbit/s and to 140 Mbit/s have been described in this article. The 2 Mbit/s to 8 Mbit/s and the 8 Mbit/s to 120 Mbit/s multiplex equipments have been developed by UK industry under BPO contracts, and have been installed on the 120 Mbit/s digital line system field-trial route<sup>3</sup>. The technique of input-signal synchronization by means of positive justification has proved very versatile; signals from different sources have been accepted without difficulty, operation has been reliable and no unexpected result has been produced. The resistance to digital errors in the transmission path, the recovery time after a break in transmission and the jitter produced have all been within the predicted limits.

The production specifications have been issued, and the changes that have been incorporated concern mainly fault indication and alarm facilities, signal-error-rate monitoring, and a degree of standardization of the mechanical layout of the equipments. No change to the basic transmission requirements has been necessary.

### ACKNOWLEDGEMENTS

The authors wish to thank their colleagues in the Telecommunications Development Department for assistance in producing this article, and also Pye-TMC Ltd. and GEC Ltd. for permission to publish Figs. 1 and 2 respectively.

### References

- <sup>1</sup> BRUGIA, O., and DECINA, M. Reframing Statistics of PCM Multiplex Transmission. *Electronics Letters*, Vol. 5, No. 4, 1969.
- <sup>2</sup> DUTTWEILLER, D. L. Waiting Time Jitter. *BSTJ*, Vol. 51, No. 1, Jan. 1972.
- <sup>3</sup> BENNETT, G. H. 120 Mbit/s Digital Line System Inauguration. *POEEJ*, Vol. 68, p. 47, Apr. 1975.

# The Thames Valley Radiopaging Trial

N. W. BROWN and D. WILLETTS, B.S.C., C.ENG., M.I.E.E.†

UDC 621.396.001.42:621.395.4

*This article first describes the radiopaging receivers used in the Thames Valley Radiopaging Trial, and continues with a description of the equipment used for controlling the sending of paging signals, including details of the method of operation. Finally, a description is given of the line and radio transmission systems used for the trial.*

## INTRODUCTION

The Thames Valley radiopaging service enables a customer carrying a pocket-sized radiopaging receiver (known as a *pager*) to be alerted to the fact that someone wishes to contact him. Each pager is associated with a 10-digit telephone number, and calls to the radiopaging service are routed to the paging control equipment (PCE) which, after processing, causes a signal to be radiated from a number of transmitters. Reception of this unique code by the pager alerts the customer by a series of audible bleeps. The normal response of the customer is then to telephone some pre-arranged number.

## HISTORY

The first UK paging systems were installed about 1956 following the development of small-size radio receivers using the, then, new transistor technology. These were mainly simple inductive-loop systems, operating inside buildings such as hospitals, and using radio frequencies below 100 kHz.

Some 10 years ago, wide-area radiopaging was introduced using frequencies in the very-high-frequency (VHF) and ultra-high-frequency (UHF) bands. Studies of systems in both public and private use throughout the world led to the decision in 1972 by the British Post Office (BPO) to enter into a field trial based on the Thames Valley area.

## RADIOPAGING RECEIVERS

Photographs of the pager are shown in Fig. 1. It is designed to clip into the breast pocket, measures 112 mm × 34 mm × 20 mm and weighs 120 g. A U-shaped metal cover acts as a loop aerial and also slides back to give access to the battery compartment. About 3-months' normal use is obtained from a single 1.4 V AA-size alkaline cell, the power drain being minimized by the use of a battery-economizer circuit. The receiver is tuned to a specific frequency in the 150 MHz band and will operate down to a radio field strength of about 5  $\mu$ V/m. The circuitry consists of a double-super-heterodyne receiver, incorporating a 17.9 MHz 4-pole crystal filter, with the majority of components being contained in 7 encapsulated modules. The signals received by the pager consist of a 2-tone sequence, and each plug-in active filter responds to one specific frequency out of a possible 60 in the range 288.5–1433.4 Hz. A potential capacity of 3540 discrete codes is provided, but as 12 tones in the range 288.5–389 Hz are unused at present, this leaves 2256 codes available for use.

† Mr. Brown is in the Telecommunications Development Department of Telecommunications Headquarters and Mr. Willetts is in the Telecommunications Systems Strategy Department of Telecommunications Headquarters

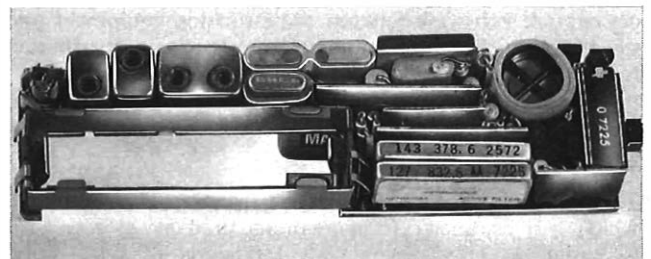

FIG. 1—Radiopaging receiver

Following the filters is the decoder module, which activates the audio circuit when the correct sequence of tones is received. The alert is sounded from an electromagnetic transducer, which is coupled to a small acoustic chamber. The alert tone consists of a pulsed 2 kHz note with an output of 80 dB standard pressure level at 300 mm.

To maximize battery life, a receiver normally cycles ON for 280 ms and OFF for 1.2 s. On detection of the first correct tone that persists for 2.7 s, the receiver remains on to decode the second tone; if this is recognized, an alert is sounded; otherwise the receiver reverts to its normal cycling pattern.

A central position on the receiver switch provides a *memory alert* facility. With the receiver switched to this position, a paging call is stored, but the alert not sounded. The normal audible alert is given when the switch is subsequently moved



FIG. 2—The paging control equipment

to the ON position; thus the user can avoid disturbing others when, for example, attending meetings. When the receiver is first switched on, a few bleeps are sounded as an indication that the battery is serviceable. It is made clear in the user's instructions that the rate of bleep will increase as the battery deteriorates, giving an indication that the battery should be changed. In practice, customers seem to be coping satisfactorily with this requirement.

### ROUTING OF PAGING CALLS

All calls to the Thames Valley trial, including those originating at exchanges for which Reading group switching centre (GSC) is the parent exchange, require the national number to be dialled. The STD access code, 0072, routes the call through Reading GSC to the level serving the PCE. Eight circuits are provided between the switching equipment and the PCE, which is situated adjacent to the main distribution frame of Reading GSC. The remaining 6 digits of the national number are accepted by the PCE.

### DESCRIPTION OF THE PCE

The PCE consists of a Metropage 10 Radiopaging Terminal, which is a proprietary item manufactured by Motorola; it is based on a processor with 16 kwords of core store, and occupies 4 cabinets. The equipment is shown in Fig. 2, and consists of a duplicated system operating in a main/stand-by mode. Each half of the PCE is operated from the 240 V 50 Hz a.c. mains supply and standard BPO 50 V battery power supplies. The a.c. mains supply at Reading is derived from 2 independent substation feeds and stand-by engine sets, with high-speed change-over arrangements.

### Facilities

The PCE provides the following facilities:

- (a) control of the service for 2000 paging numbers, with extension on a unit basis up to 10 000 paging numbers,
- (b) control of up to 16 base stations,
- (c) provision of the necessary supervisory conditions, including optional line reversal, for connexion to the public switched telephone network (PSTN),
- (d) provision of a recorded announcement, changeable at will by the BPO, to advise the calling party if the number dialled is valid,

- (e) transmission of paging codes in batches at programmable intervals,
- (f) provision of group call facilities, whereby more than one pager can be alerted by dialling only one paging number,
- (g) the ability to change readily, from remote administration centres, the service given to each paging number, and
- (h) the provision of system statistics, including
  - (i) the number of valid and invalid calls received and the elapsed time since the statistics were last reset,
  - (ii) the number of calls received for each paging number,
  - (iii) the traffic rate, averaged over all paging numbers, and
  - (iv) the grade of service.

### OUTLINE OF OPERATION OF THE PCE

A block diagram of the principal modules of one half of the PCE is shown in Fig. 3. For every incoming circuit from the switching equipment, both halves of the PCE are equipped with a dial-pulse line receiver, a dial-pulse logic module and an input register.

### Input Circuit

#### *Dial-Pulse Line Receiver*

Signalling between the switching equipment and PCE is by loop-disconnect pulses over the negative and positive wires. Facilities are provided for battery or disconnection testing of the P-wire. The incoming circuit is terminated at a pulsing relay and audio transformer. The pulsing relay electrically isolates the PCE from the switching equipment. A similar arrangement is incorporated for the P-wire. A recorded announcement or number-unobtainable (NU) tone can be applied to the incoming circuit by means of the audio transformer. A line-break jack, a monitor point and a manual-busy switch are provided on the front panel of each dial-pulse line receiver.

#### *Dial-Pulse Logic Module*

The dial-pulse logic module accepts the pulses from the pulsing relay contacts of the dial-pulse line receiver and, after eliminating contact bounce, regenerates the pulses.

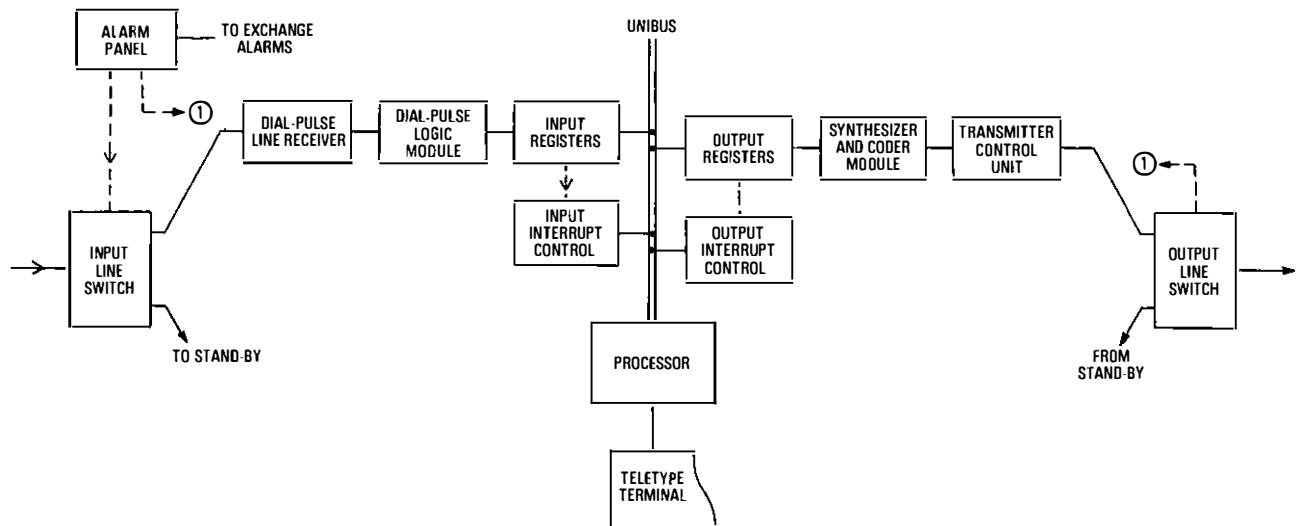

FIG. 3—Block diagram of the paging control equipment

Timing circuits monitor the pulse transitions to distinguish between, and generate, supervisory conditions indicating

- (a) seizure,
- (b) digit pulses,
- (c) inter-digit pauses, and
- (d) release.

The serial pulses of each digit are converted to parallel binary-coded-decimal (BCD) form. When an inter-digit pause is detected, the BCD digit is extended to the input register, and the timing and counting circuitry reset. The supervisory conditions are also indicated to the input register and the dial-pulse logic module receives from the input register supervisory indications of the P-wire state, line reversal, and the recorded announcements to be returned to the incoming line. The dial-pulse logic module provides a visual display of the BCD digit from the time a digit is received until it is transferred to the input register.

#### Input Register

The input register is the interface between the processor and the dial-pulse logic module, from which the input register receives the BCD digits and supervisory indications. When a digit is ready to be transferred to the processor, or when a supervisory condition changes state, the input register sends a signal to the interrupt control module which causes an *interrupt* signal to be sent to the processor; an *interrupt* signal informs the processor that a peripheral device requires communication. The processor then executes a routine to poll the input registers and determine which one initiated the *interrupt* signal.

Input registers are grouped, both electrically and physically, in shelves of eight. Each group is served by an address decoder. The processor recognizes the address decoder that is associated with the *interrupt* signal, so that it is necessary to poll only the 8 input registers controlled by that address decoder. When the interrupting input register is found, the data are transferred to the processor. The input register also receives data from the processor that cause the return of appropriate supervisory conditions and announcements to the incoming circuit via the dial-pulse line receiver and the dial-pulse logic module.

#### Dial-Pulse Test Unit

This unit provides a means of testing each dial-pulse line receiver and the attendant input interface by simulating an incoming call. The test unit includes a rotary-dial assembly,

control switches, indicator lamps and a jack to permit the unit to be patched to any dial-pulse line receiver.

#### Input-Call Processing

The input registers are connected to the processor by a 16-wire data highway (the *mibus*). The processor accepts and transmits 16 bit words of data to and from the data highway. All peripheral equipment that communicates directly with the processor is connected to the data highway.

The programme controlling the processor reserves an area of core store for the data from each incoming circuit from the PSTN. Each digit of a paging number is examined after it has been received. In the Thames Valley system, the first 2 of the 6 digits allocated are the same for all valid paging numbers. If the first 2 digits do not satisfy this check, NU tone is sent to the incoming circuit; if the first 2 digits are correct, the final 4 digits are received and stored. When all are present, the 4 BCD digits are converted into a binary number, which is processed to give the address of the location in the core store where the information on the required paging number is stored.

The subscriber's record contains the following information:

- |                         |         |
|-------------------------|---------|
| (a) active or inactive  | 1 bit,  |
| (b) group call          | 1 bit,  |
| (c) output-area address | 4 bit,  |
| (d) pager type          | 2 bit,  |
| (e) call count          | 8 bit,  |
| (f) pager code          | 16 bit, |
| (g) output flag         | 1 bit.  |

With the exception of the call count and output flag, the information in the subscriber's record is set by routines initiated from the remote or maintenance teletype terminals.

If, when a paging call is received, the paging number is shown in the subscriber's record as active, the call count is incremented and the output flag set. The processor instructs the input register to send the recorded announcement to the incoming circuit. If the paging number is inactive, either because the paging number is spare or because service has been terminated, NU tone is sent to the incoming circuit.

Timing circuits are started when seizure occurs and also on the application of NU tone or the recorded announcement. NU tone is sent to the incoming circuit if 6 digits have not been received within 15 s of seizure. The condition applied to the P-wire is restored to the free state 10 s after the

connexion of the recorded announcement or NU tone. This facilitates forced release under called-subscriber-held conditions if the PCE is situated in a backward-holding switching environment.

**Output-Call Processing**

The PCE controls up to 24 transmitters, which can be activated according to a flexibility arrangement included in both the hardware and the software. In the subscriber's record, there is an output-area address. Each of the 16 output-area addresses can cause a paging call to be transmitted at one, or any combination of up to 24 transmitters. If there is more than one transmitter in the system, either sequential or simultaneous operation of the radio transmitters must be specified.

The normal service offered to customers in the Thames Valley uses only one output-area address, which causes simultaneous transmission from all radio transmitters in the coverage area. Other output-area addresses are used for maintenance purposes: one allows a sequential transmission by all radio transmitters; others allow for transmissions from particular stations.

Paging calls are transmitted in batches, according to output-area address. Each output-area address has a cycle time that is variable between 1-999 s, in 1 s steps. Timing commences at the end of a transmission of a batch of paging codes for an output-area address. Paging calls for that output-area address are then stored until the chosen cycle time has elapsed.

When the cycle time elapses, the processor scans the subscriber's records looking for those paging numbers with the output flag set and an output-area address corresponding to that being transmitted. A copy of the paging code is transferred to the output registers in preparation for transmission to the radio network. The output flag is restored to the normal state and, while the paging call is being sent to the radio transmitter, the scan continues to search for any other paging numbers having that output-area address and requiring paging. When all subscribers' records have been scanned once, the cycle timer is reset and the process continues.

**Output Registers**

The processor communicates the pager code, transmitter-control-unit group address, alarm and status information to the other output modules by depositing two 16 bit words of information in 2 output registers. When the paging call has been transmitted, the output registers interrupt the processor to initiate the sending of the next paging call. The address decoder and interrupt arrangements to service up to 10 output units are similar to those provided for the input registers.

**Synthesizer and 2-Tone Coder Module**

The synthesizer accepts the data stored in the output registers and produces the corresponding tones. The 2-tone coder controls the timing of the tones constituting the paging call. The tones are derived from a 12.288 MHz crystal oscillator and frequency dividers programmed by the output registers. The maximum programmable divisor is 65 536, giving a minimum frequency of 94 Hz. The output from the synthesizer is applied to a programmable filter which modifies the square wave produced by the dividers, reducing the harmonic content, so that the output resembles a sine wave.

**Transmitter Control Unit and Interface**

The transmitter control unit monitors the operation of the transmitters, generates alarm signals to indicate transmitter malfunctions, and is the interface between the synthesizer

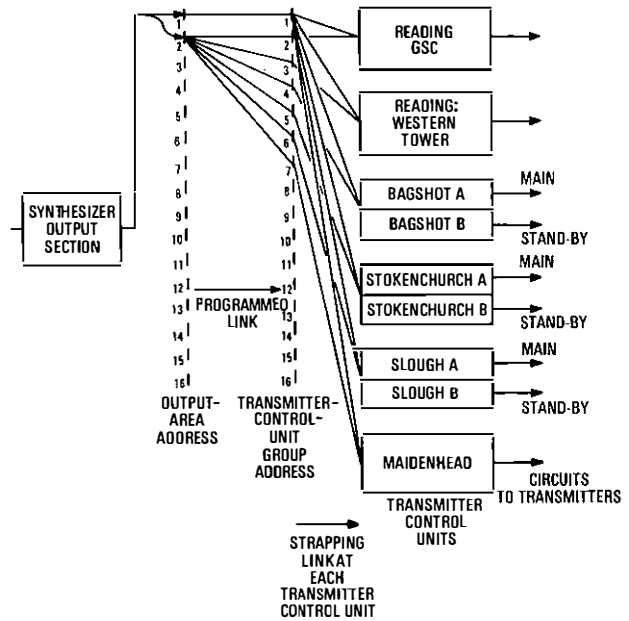

Note: Output address 1 causes simultaneous excitation of all transmitters; output 2 causes sequential excitation of each transmitter in turn

FIG. 4—Block diagram of connexions to transmitter control units

and the circuits to the radio transmitters. A separate transmitter control unit is provided for each circuit to a radio transmitter. The 4 bit transmitter-control-unit group address is decoded using a 1-out-of-16 decoder, which produces an output on a different pin for each combination of inputs. Wire straps enable any group address to be selected.

In the simultaneous mode of transmission, the transmitter control units constituting the simultaneous group are all strapped to respond to the same group address and, in the sequential mode of transmission, are strapped to respond to different group addresses. The software link between output-area address and transmitter-control-unit group address is programmed from the maintenance console, and a typical arrangement is shown in Fig. 4. If the simultaneous mode is designated, only one group address is specified in the output configuration command. In the sequential mode, the group addresses are presented sequentially at the output register, but with the same pager code, so that the appropriate transmitter control units are each activated, in turn, while the paging call is transmitted.

The supervisory signals sent to, and received from, the radio transmitters are monitored and, if any irregularity is noted, the transmitter control unit generates the appropriate alarm.

The front panel of the transmitter control unit accommodates a line-break jack and a monitor point, a manual transmitter turn-off override switch, a TRANSMITTER ON lamp, an ALARM lamp and an ALARM RESET key.

**REDUNDANCY**

There is no direct communication between the processors in the main and stand-by PCEs. Thus, it is necessary to maintain separately the core image of the programme and subscriber's data at the main and stand-by equipments. The input and output lines are routed to the main or stand-by PCE via a change-over system, which is operated from the major alarm outputs. The service is normally provided by the main, and there is automatic change-over to the stand-by if a major alarm occurs.



## ALARM PANEL

There is a comprehensive alarm panel which displays the status of the modules. Alarms are classified into major alarms which are caused by faults that affect the service and are broadly synonymous with the BPO prompt alarm, and minor alarms which are caused by non-critical faults and are similar to BPO deferred alarms.

## MAINTENANCE AND CONTROL CONSOLES

Maintenance and control facilities are provided at the processor console, and also by means of the maintenance teletype terminals. The processor console enables the programme to be stepped one instruction at a time, the instructions being displayed on a 16-lamp display. A set of 16 keys allows an instruction to be modified, and the data words can be manipulated in a similar manner. The processor console is used for the initial configuration of the system and also for processor fault finding. Sufficient instructions are input at the key panel for the processor to read in the paper tape containing the main programmes.

The main programme tapes contain the maintenance teletype software modules; the maintenance teletype terminals cannot, therefore, be used until the main programme tapes have been read. Thereafter, the maintenance teletype terminals are used for system control.

Before the PCE is made available for service, the input and output parameters are specified. The input parameters are specified for each incoming line, and include the number of digits to be received and the constant prefix digits. The holding time before forced release is the same for all input lines and is specified at the end of the line parameters. The output parameters are specified for each output-area address, and include the relevant output unit, mode of paging, cycle time and transmitter-control-unit group addresses.

The input and output parameters can be individually reset without having to input the whole information again. An instruction from the maintenance teletype terminal causes the input and output parameters to be dumped on paper tape, so that subsequent reloading, without alteration, can be accomplished quickly and easily.

Error messages generated while the system is on-line are displayed at the maintenance teletype terminals. If the fault is located to a module or section, its identity is also displayed. The programme does not provide an on-line background fault-finding routine, so that errors and failures are listed when they are encountered. In the case of complete failures, such as a power failure, the nature of the fault and time of occurrence are listed when the system is restored, unless it is necessary to reprogramme the PCE which causes loss of the fault report. Comprehensive diagnostic tapes are provided for maintenance purposes. Before the diagnostic routine can be executed, the half of the PCE to be analysed is taken out of service.

## LINE NETWORK AND SIGNALLING ARRANGEMENTS BETWEEN PCE AND RADIO TRANSMITTERS

Circuits to standards similar to those of Tariff S3, but with metallic d.c. paths over designated A-wire and B-wire pairs, are used to convey radiopaging calls from the PCE at Reading GSC to the transmitters at Maidenhead, Slough, Bagshot and Stokenchurch. Alternatively-routed main and protection circuits have been provided, and the continuity of these is monitored by pilot tones at a frequency of 2.75 kHz. There is also a 1.7 km unloaded connexion between the GSC and a transmitter at Western Tower, a British Railways tower block opposite Reading railway station, and an internal tie-line within the GSC to a transmitter located on the third floor.

At the radio stations, the transmitters operate in the stand-

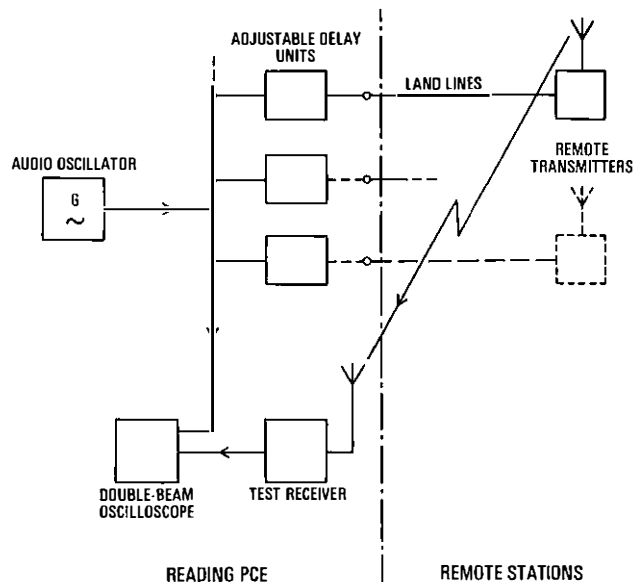
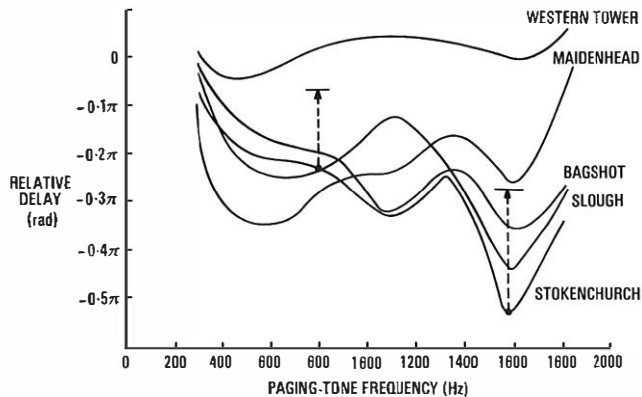

FIG. 5—Block diagram of equipment for measuring relative phase

by mode with the high-voltage supply to the output tubes disconnected during the period between calls.

The presence of a  $-50$  V condition on the B-wire is used to activate the transmitters and, prior to traffic being passed, the performance of each is checked by means of test tones generated by the synthesizer. Provided that the modulation and output-power conditions are within limits, the associated transmitter control unit receives an earth condition signalled back on the A-wire. Absence of an earth indicates a fault and an alarm is given, though at certain radio stations, stand-by transmitters are provided and these automatically switch into service if any main transmitter fails to operate.

Paging receivers can occasionally receive near-equal radio fields from 2 or more transmitters, and so it is important that the phase relationship of tones modulating the transmitters is controlled to avoid signal cancellation. In practice, a maximum phase error of  $\pm 60^\circ$  between any 2 transmissions is required for each signalling tone applied simultaneously to the 6 transmitters; this has been achieved by time-delay equalization on all main and protection circuits between the PCE and the transmitting sites. The provision of similarly-routed return pairs from each site enabled loop measurements of delay/frequency to be made, and the results agreed closely with calculated values. The propagation delay of 0.9 mm cable, loaded with 88 mH/1.829 km is about  $44 \mu\text{s}/\text{km}$  and, for the route lengths involved, it was necessary to build out the delay on each circuit to 3.5 ms; this included some margin for possible rearrangements. Adjustable delay units are provided in the PCE for this purpose and, in their final alignment, these were adjusted to the nearest 0.05 ms setting. Fig. 5 shows the test arrangement which was used to observe the phase relationship between transmitted and received signals. On each circuit, the 2 signals were near to phase coincidence at 8 frequencies in the range 0.3–1.9 kHz, and the delay units were adjusted to minimize the relative phase error at these frequencies. The results are given in Fig. 6 which shows the residual phase error, though the delays are less than those indicated, since the measurements include delays due to radio propagation. The effect of the radio path for the 24 km path between Stokenchurch and Reading ( $80 \mu\text{s}$ ) is indicated by the dashed arrows on the appropriate curve. For shorter paths and lower signalling frequencies, the corrections are proportionately less.



Note: Correction for delay in radio path between Stokenchurch and Reading is shown by dashed arrows

FIG. 6—Measured phase/frequency characteristics of line network

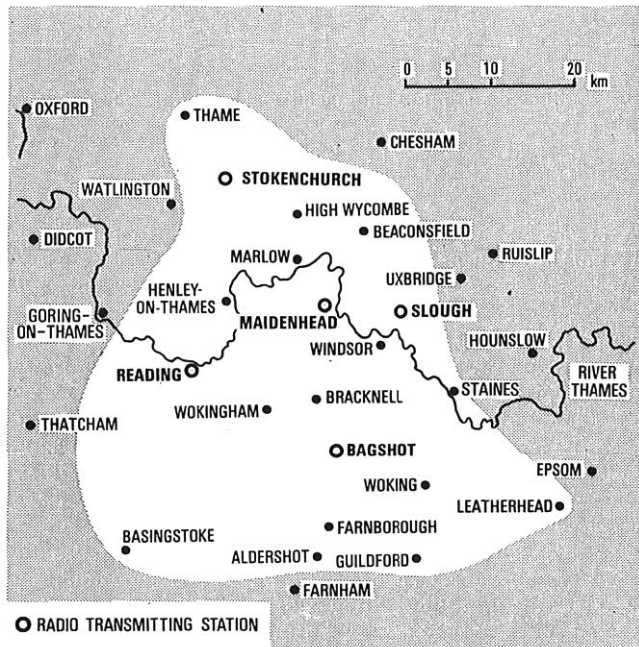

FIG. 7—Radiopaging coverage area (unshaded area)

### TRANSMITTER SITES AND EQUIPMENT

The transmitters operate in the 150 MHz band and use frequency modulation. The location and spacing of the 6 sites were decided from theoretical considerations, supported by experimental tests of pager performance in London. The aim was to achieve an area of continuous radio coverage with a boundary determined by a calling reliability of 95% inside buildings. The actual service area is shown in Fig. 7.

Bagshot and Stokenchurch are microwave radio stations affording excellent radio coverage to the north and south of the coverage zone. These stations are provided with stand-by transmitters and change-over equipment designed by the BPO. In Reading, 2 sites are used; Western Tower provides the best radio coverage, but the main power supply is un-protected, and so a transmitter in the GSC acts as a stand-by. Normally, both of these transmitters are operated in parallel, but for test purposes, the one at the GSC can be switched off, enabling the aerial to be used for monitoring the remote stations. The Slough installation at the telephone exchange has a main and stand-by transmitter similar to those used at

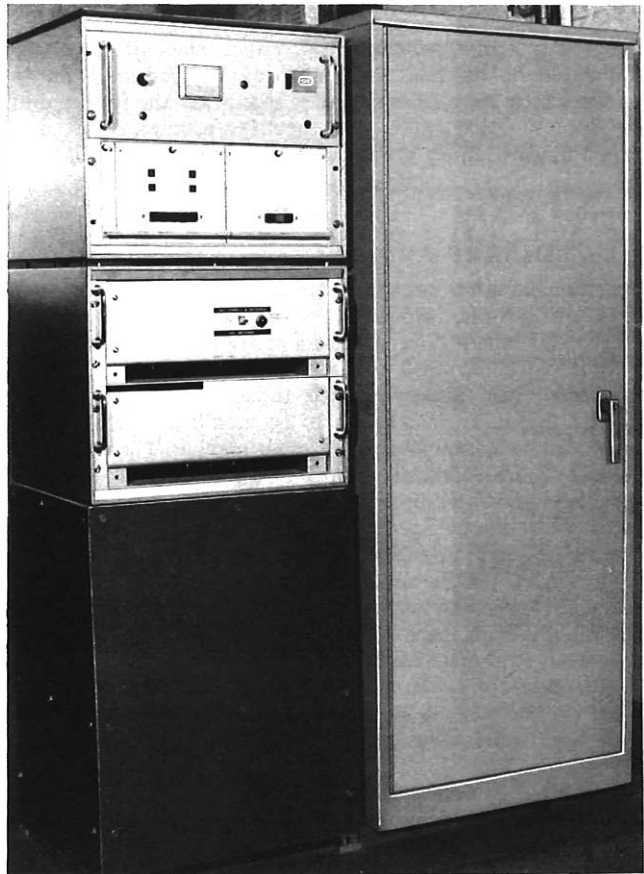

FIG. 8—Transmitter installation

Bagshot and Stokenchurch, but at Maidenhead, only one transmitter is used for local coverage.

Effective radiated powers of 100 W are used, the output power of each transmitter being appropriately adjusted to allow for aerial gain and feeder loss. At Stokenchurch, a 3-element Yagi aerial directs radio signals towards the steeply-contoured High Wycombe area, but at all other sites, co-linear type aerials are used. These consist of 4 phased elements, stacked vertically to restrict radiation to a narrow lobe in the vertical plane. By this means, a gain of approximately 6 dB is achieved relative to that of a simple dipole. Weather-proofing and strength are obtained from a fibre-glass encapsulation of the whole structure, which then resembles a flag staff in profile.

The main transmitters are supplied by Motorola and are capable of delivering a radio-frequency (RF) power of 150 W from a pair of convection-cooled tetrodes. Two tubes are used in the driver unit; otherwise, transistors are used in the early stages. The carrier frequencies are stable to within 8 Hz/month, and the crystal oscillators have been preset to give carrier frequency offsets of 50 Hz and 100 Hz. The use of frequency offsets minimizes the duration of fading of signals that can occur in areas where the radio fields of the transmitters overlap. It is important that the beat notes between transmitters do not extend into the paging-tone frequencies of 288.5 Hz and above. Measurements of carrier frequencies show, however, that the drifts are small and within the specified limits.

The stand-by transmitters are supplied by GEC/Marconi and can supply an RF output of 60 W. Each is fitted with a high-stability crystal to ensure that the frequency offset pattern is maintained if a stand-by transmitter is brought into service. A photograph of a transmitter installation is shown in Fig. 8.

## AUTOMATIC CHANGE-OVER EQUIPMENT AT RADIO STATIONS

At Bagshot, Stokenchurch and Slough, automatic change-over equipment has been provided by the BPO to ensure continuity of service if the main line or transmitter fails. Normally, the main line is connected to the main transmitter and the local control unit causes the supply voltage to be applied to the output stage each time a  $-50\text{ V}$  condition appears on the B-wire. During a brief period of test tones transmitted from the PCE, checks are made for the presence of audio-frequency signals at the transmitter modulator and RF power at the aerial terminal. If these signals are present, an earth is returned to the PCE on the A-wire, indicating that the transmitter is functioning correctly. If the main transmitter fails, the line is switched to the stand-by transmitter and the aerial connexion transferred. Assuming a successful change-over occurs, then an earth condition is returned to the PCE, whereupon paging calls are radiated using the stand-by transmitter. Another function of the change-over equipment is to filter and detect the  $2.75\text{ kHz}$  pilot tones transmitted from the PCE at a level of  $-20\text{ dBm0}$  on both main and stand-by circuits. The transmitters switch to the stand-by circuit if the pilot-tone level of the main circuit falls by more

than  $3\text{ dB}$ . Local and extended alarms, and a manual override facility, complete the functions of the change-over equipment.

## CONCLUSIONS

Popularity of the radiopaging service with customers has been demonstrated by system growth and, compared with the telephone service, less than average cessations.

Faulty paging receivers have been speedily replaced with a minimum of inconvenience to customers, and the duplicated control equipment has maintained continuity of service through all the minor faults that have occurred. The line network and transmitters have been virtually trouble-free.

Encouragement from the trial has led to the decision to provide a high-capacity system for Greater London; service here should open later this year. Concurrently, plans are being worked out for a national system.

## ACKNOWLEDGEMENTS

The authors wish to thank Motorola Electronics Ltd. for permission to publish details of the Metropage 10 radiopaging equipment, and also the many colleagues in Reading Telephone Area who helped with the equipment installation and are responsible for the day-to-day running of the trial.

---

## Book Reviews

*The World's Submarine Telephone Cable Systems.* H. H. Schenck. Published by the Office of Telecommunications, US Dept. of Commerce. vii + 291 pp. 41 ills. Obtainable from the Superintendent of Documents, US Government Printing Office, Washington DC 20402. \$3.55.

This compendium lists the world's submarine-cable systems in service in 1974, together with those under construction, under international tender, or expected to be in service within the next decade. It has been prepared under contract for the Office of Telecommunications Policy of the US Department of Commerce, and is intended for the scholar and engineer in the technical telecommunications industry. The listing is preceded by a 32-page introduction to submarine-cable history and technology, which gives a concise and informative review of the specialized aspects of system engineering, project planning, and manufacturing and laying of submarine cables. The characteristics required for cable ships and cable-laying equipment are also described. The technical level of the introduction has been well chosen to make it of interest to the non-specialist, and takes account of latest developments, such as the pan-loading of cable-repair ships.

The listing of systems, and the comprehensive data profile of each system, take up 240 pages of this 291-page book. In view of the difficulty of obtaining and printing such a mass of information, it is perhaps not surprising that there are some errors. Nevertheless, the book is a mine of information, giving valuable technical and economic data for the systems. Each profile also contains a sketch map showing the location of the system referred to, together with other systems in the vicinity. The book is completed by a comprehensive glossary of terms used in the submarine-cable industry.

The presentation of such a large amount of data has been carefully thought out and well indexed. The work will form a uniquely valuable reference book for students and practi-

tioners of the submarine-cable art, and is a useful introduction to this field for newcomers.

W. G. S.

*Basic Electric Circuits* (second edition). A. M. P. Brookes, M.A. Pergamon Press Ltd. viii + 353 pp. 279 ills. Hard cover: £5.00; flexible cover: £3.50.

This book has been written for first-year or second-year engineering undergraduates, and thus assumes an appropriate level of mathematical ability. The pace at which the reader is taken through the subject matter is also indicative of the anticipated intellectual level of the reader. The style is clear and precise.

The book starts with a basic treatment of conducting and insulating materials, and semiconductor-junction devices. It progresses through resistive, capacitive and inductive circuits and their combinations, followed by graphical and symbolic methods of analysis. Network theorems and bridge networks are followed, surprisingly, by a 9-page chapter, "Elementary Transmission-Line Analysis"; the treatment is brief rather than elementary. The latter part of the book covers tuned circuits and filters, polyphase circuits, simple transients, non-sinusoidal excitation, tubes and transistors as circuit elements, amplifiers and oscillators.

There are numerous worked examples throughout the book, and typical examination questions with answers at the end of each chapter. The text is liberally illustrated with figures, which are, disappointingly, not in accordance with BS 3939. It is also disappointing to find that, although the preface states that, "In general, the MKS system of units has been used", frequency is still referred to in cycles/s, and miles are used in preference to kilometres.

R. H.

# The Protection of Operational Buildings against Gas Entry

R. H. ADAMS, C.ENG., M.I.E.E., and R. THARBY, B.SC.(ENG.), C.ENG., M.I.MECH.E., M.I.E.E.†

UDC 614.8:699.871:696.2

*Gas leaks from defective mains into underground ducts have increased in both frequency and scale, and place at risk any building where the lead-in ducts are sealed inadequately. To minimize the danger, various protective measures have been devised to provide more protection than a simple duct seal. In this article, the philosophy behind the selection of these measures is outlined and the equipment concerned is described.*

## INTRODUCTION

Networks of interconnected ducts carrying telephone cables become contaminated quickly if gas leaks from faulty joints or cracks in near-by gas mains, because a low-resistance path away from the leakage area is provided. Gas mains and British Post Office (BPO) telephone cable ducts are often buried close together under impervious surfaces which trap the gas underground, and it is not economically feasible to construct the ducts to gas-tight standards.

The danger to staff and plant arising from gas leakage is well recognized, and tests are made before underground plant is entered. Operational buildings, such as telephone exchanges, are protected at present by sealing all ducts leading in to the building.

The problems of gas leakage have changed in recent years, during which the gas industry has undertaken a series of modernization programmes to meet the increased demand for supplies and to take advantage of the discovery of North Sea gas. At first, small gas plants were closed and production of reformed gas concentrated on a reduced number of centres, and then, later, supplies of natural gas were distributed nationally by pipeline. Two aspects of these changes have affected the degree of leakage: firstly, the wide use of medium-pressure (20–200 kPa) and high-pressure (up to 7 MPa) mains lead to larger escapes of gas being experienced; secondly, the “dry” nature of natural gas (mainly methane) tends to shrink the caulking of traditional pipe joints and causes the joints to leak.

Other factors that increase the hazard are the growing disturbance of

- (a) gas mains during excavations in the highway, and
- (b) duct seals in telephone exchanges during new cable installations to expand the network.

In these circumstances, a building is at risk at all times if its duct seals are not entirely effective, and especially so if a significant gas leak occurs at the time when a seal is displaced for current work or is awaiting restoration. The main problem arises in an enclosed area, into which gas accumulates with time and is then ignited by a spark. The highest risk arises, therefore, in unventilated rooms containing electrical equipment in a locality where there is a high risk of gas leaks; for example, where there has been a recent change-over to natural gas.



FIG. 1—Madeley exchange after gas explosion

## HISTORY OF EXPLOSIONS

Telecommunication equipment is not designed to be flame-proof, nor is it usually economic to make it so. Accordingly, if sufficient gas enters a building to form a 100% lower explosive limit\* mixture with air (6% by volume for reformed gas or 5% by volume for natural gas), an explosion is likely

\* Lower explosive limit of a gas (or a mixture of gases) is the minimum volume of the gas that must be present in 100 volumes of the gas-air mixture to enable combustion to occur

† Mr. Adams is in the Service Department, Telecommunications Headquarters, and Mr. Tharby is in the Operational Programming Department, Telecommunications Headquarters



FIG. 2—Bishopwearmouth exchange after gas explosion

to occur. The consequences of such an explosion can best be appreciated from an outline of the cases that have arisen.

Two unit automatic exchanges (UAXs) have been destroyed completely; one at Takeley in Cambridge Area in 1962, and the other at Madeley<sup>1</sup> in Stoke-on-Trent Area in 1968. In each instance, the building was fortunately unattended at the time of the explosion. Fig. 1 illustrates the scene at Madeley exchange after the explosion. Takeley village had no gas supply at the date of the explosion, which was caused by the fracture of a medium-pressure main that linked 2 near-by towns and merely passed through Takeley.

One explosion occurred in a major building basement complex in Birmingham in 1961. The gas may have been ignited by the boiler plant. One BPO Cleaner was killed and some 30 people injured by the explosion.

The most recent explosion happened at Bishopwearmouth, Newcastle-upon-Tyne Area in 1974, and the circumstances of the case are still being studied. A 5000-line non-director satellite exchange was demolished, fortunately after staff who had been working there had left. The scene after the incident is illustrated in Fig. 2.

In all the cases where exchange buildings were destroyed, there was widespread damage to neighbouring property and some minor injuries to residents. Telephone Area staffs performed miracles of ingenuity and endurance to restore service with mobile exchanges and diversions, but despite these efforts, some weeks elapsed before all lines were restored.

### PRINCIPLES OF PROTECTION

Remedial work on duct seals in all exchanges was instituted after the explosions described above. From the results, it was evident that the standard of seal achieved varied according to local circumstances, and that complete reliance on the seals alone was unwise. The intense interest shown by staff after an incident, in checking and improving seals, declined progressively as memories of the explosion faded. Furthermore, as a result of the higher gas-supply pressures being used, a situation was envisaged where sufficient gas could escape to generate a slight pressure in an exchange manhole and test severely any defective seals. To meet the risk to staff in a building, a device to provide an alarm in the event of gas ingress was judged to be desirable.

A complete protection system was therefore devised which allowed for these factors and provided a series of protective features. To allow for human errors and the passage of time, a series of measures was chosen that provides adequate safeguards even if one feature is defective, and gives some protection with as many as three below standard. Five separate measures are used as follows.

(a) The exchange manhole is effectively ventilated to disperse gas from minor leaks and prevent pressure being applied to duct seals.

(b) All lead-in ducts to the building are sealed in the exchange manhole.

(c) All lead-in ducts are sealed in the cable chamber or trench.

(d) The cable chamber or trench is ventilated to disperse any slight ingress that passes the seals.

(e) An active gas monitor is installed in the cable chamber or trench of permanently-staffed buildings, to warn staff if small gas concentrations arise, and sound an evacuation signal if the concentration reaches dangerous proportions.

The philosophy of providing a number of safeguards accepts the possibility that, at the critical moment of gas leakage,

(a) the duct seals may be imperfect or displaced for cabling,

(b) ventilation ducts may be partly blocked, or

(c) the gas monitor may be out of service temporarily.

The probability of all 3 failures occurring simultaneously is very small indeed.

### SEALING LEAD-IN DUCTS

A number of different methods are currently used for sealing lead-in ducts, alternative systems having been devised to meet the progressive change from earthenware to PVC ducts, and from lead to polyethylene cable sheaths. The 6 principal systems are illustrated in Fig. 3(a)–(f). In each case, seals must be achieved between the outer surface of the duct and the building, and between the inner surface of the duct and the cable sheaths. Seals are achieved by the following methods in the examples illustrated.

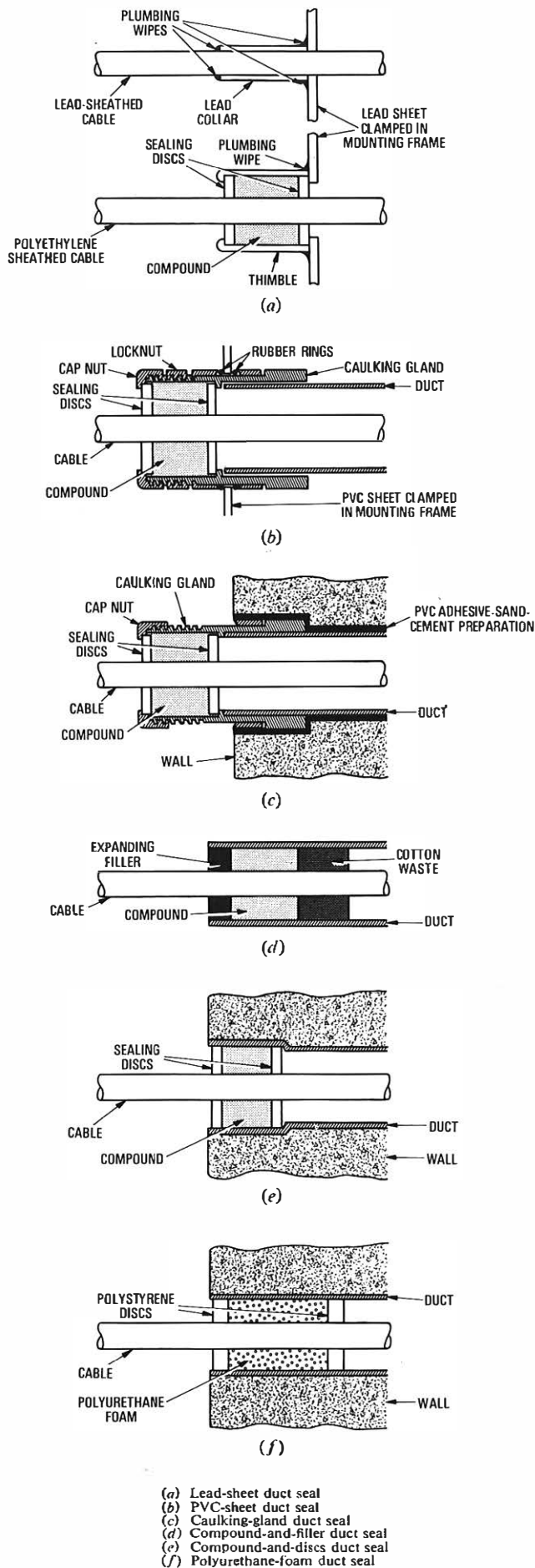

FIG. 3—Alternative methods for sealing lead-in ducts

(a) *Lead-Sheet Duct Seal* A lead sheet is clamped in a frame that is mounted on the wall; see Fig. 3(a). Each lead cable sheath is plumbed to the lead sheet; polyethylene and protected lead-sheathed cables are sealed by discs and packing compound in thimbles that are plumbed to the lead sheet.

(b) *PVC-Sheet Duct Seal* A PVC sheet is clamped in a manner similar to method (a) above, and sealed to each duct by a caulking gland fitted with rubber sealing rings; see Fig. 3(b). The seal between the duct and the cable is made by a compound compressed between sealing discs under the cap of the caulking gland.

(c) *Caulking-Gland Duct Seal* The outer surface of the duct is coated with a mixture of PVC adhesive, sand and cement, and then built directly into the wall, as shown in Fig. 3(c). The cable is sealed to the duct as in method (b) above.

(d) *Compound-and-Filler Duct Seal* Cotton waste is used to centralize or separate individual cables in the duct, a compound effects a seal and a non-shrink filler provides rigidity; see Fig. 3(d).

(e) *Compound-and-Discs Duct Seal* A compound is compressed between sealing discs, the socket of the duct being used to locate the inner disc, as shown in Fig. 3(e).

(f) *Polyurethane-Foam Duct Seal* Polyurethane foam is injected and expanded between polystyrene discs that have been cut to fit around the cables; see Fig. 3(f).

Methods (a) and (b) are not usually used for nests of ducts of less than 4 ways, and are now superseded by method (c). Methods (d), (e) and (f) are normally used in exchange manholes. Methods (d) and (f) have the advantage of being able to be applied to ducts that are already cabled, and are widely used when seals are applied retrospectively. Difficulty in gaining close access to duct-mouths for retrospective sealing influences the method chosen, and some buildings demand unusual solutions. In one case, an extra bulkhead wall with duct seals has been provided. In another, ducts that were fully cabled, and not needed for further development, were filled with non-shrink grout to effect a seal.

New methods for sealing ducts are being developed, incorporating integral failure alarms to monitor their efficiency. Seal-checking methods used at present rely on a regular visual examination, or a tracer-gas testing system; this uses sulphur hexafluoride ( $\text{SF}_6$ ) injected behind the seals, leaks through the seal being detected by a sensor working on the electron-capture principle. This test is extremely searching, and its complication and expense is justified only for special cases. Reliance is generally placed on a thorough visual examination and strict oversight of all work that involves the disturbance of duct seals. Whenever a seal must be removed for a significant period, the building can be protected by the installation of a temporary gas monitor if one is not already installed.

Little benefit is likely to be gained from the improved standard of sealing of all telephone cable entries unless other service pipes (for example, gas, water and electricity) are also sealed to a similar standard. Sealing methods (d) and (f) above provide suitable facilities. These seals should also be examined regularly.

The difficulties met in sealing underground leads-in has stimulated studies of alternative methods that provide equal security for cables without introducing gas hazards into buildings.

## VENTILATING EXCHANGE MANHOLES

The low densities relative to air of natural gas (0.6) and reformed gas (0.5) make it feasible to disperse gas from manholes by ventilation. Traditionally, ventilation has been provided only in special instances; for example, where the

stability of adjacent buildings may be affected by a gas explosion in the manhole. In these cases, ventilated covers are used, but these have the following disadvantages:

- (a) they become blocked by fallen leaves or other street debris,
- (b) they afford easy access for children to insert lighted matches or fireworks, and
- (c) they provide a poor degree of ventilation.

A more satisfactory standard of ventilation is provided by a vent pipe at least 7 m high, connected to the upper level of a manhole by a suitable duct. As the connecting duct is likely to be almost horizontal, apart from a slight slope for drainage, it should be as short as possible, preferably less than 3 m. No air inlet is needed since this is provided by the duct network entering the manhole. If this becomes completely sealed by water, the risk of gas entry is low and the need for ventilation reduced.

The vent pipe can take any convenient form which blends with the local environment; for example, a hollow lamp standard matching those in the street, or a vertical pipe attached to a building and similar to the drainpipes in use. The outlet of the vent pipe discharges into free air above the level of building eaves and clear of near-by trees. It is terminated by a fitting to keep out the rain and prevent blockage by birds' nests. A typical vent pipe installation is shown in Fig. 4.



FIG. 4—Vent pipe at exchange manhole

The bore of the vent pipe should correspond to the size of the manhole, but may be limited by aesthetic considerations. For most instances, a 125 mm bore vent pipe, rising at least 7 m, should be adequate when connected to the manhole by 2 ducts of 90 mm bore. Tests at such an installation showed that the system could deal with natural gas which entered the manhole continuously at a rate exceeding  $0.6 \text{ m}^3/\text{h}$ , without allowing the gas concentration to rise to the lower explosive limit. Such a rate of ingress is unlikely to be experienced in practice unless several joints in near-by gas mains are leaking simultaneously, or a fracture of a gas main has occurred.

The situation of a manhole can, in some cases, make the location of a vent pipe difficult or expensive. Where this arises, and especially if the lead-in size is small, an interception box can be installed at a point where a vent pipe can be provided easily, and ventilation and duct seals applied to this box.

## VENTILATING CABLE CHAMBERS

Cable chambers were once regarded as safe from gas contamination due to the presence of a duct seal. However, recent experiences show that gas can sometimes enter the cable chamber, and gas tests are now made before work in the chamber commences. It is hoped that the improvement of duct seals and the ventilation of exchange manholes will restore the former security of cable chambers, but until this is achieved, additional safeguards are needed.

Cable chambers in new buildings have ventilation outlets at high and low levels, and the area of these outlets is about 0.5% of the floor area of the chamber. Existing buildings also need ventilating to similar standards, but structural problems make this difficult to achieve in all cases. Each building is being examined separately, with account also being taken of the proximity and leakage history of local gas mains, the standard of duct seals achieved and the ventilation standard provided at the exchange manhole. Underground rooms with no ventilation at all provide an undesirable void in which leaking gas can accumulate, and any degree of ventilation, however small, is better than none.

Mechanical ventilation systems can be used to solve some difficult cases, but reliance on mechanical methods must be reinforced by checks which ensure that the system is maintained in good order. Exhaust air from cable-pressurization plant can be used conveniently to supplement natural forces, and development trials to verify the merits of these and other aids to ventilation are in progress.

Cable trenches take the place of cable chambers in smaller buildings, and are ventilated by air bricks at high and low level near the duct seals. The air bricks have an effective ventilation surface area of 0.1% or 0.2% of the trench floor area, depending on the depth of the trench.

Where the cable chamber or trench forms part of an open basement complex, ventilation and other gas-protection problems are simplified if the area adjacent to the cable entry is enclosed. This localizes the scope of any contamination, isolates it from potential sources of ignition, and contains it to facilitate detection by gas monitors and dispersal by ventilation.

## MEASUREMENT AND MONITORING OF GAS CONCENTRATION

Instruments for making spot tests for flammable gases are widely used, and such a device is used in the BPO to verify the safety of atmospheres in manholes and jointboxes.<sup>2</sup> Gas is usually detected by its combustion in the presence of oxygen on the surface of a heated wire coated with a catalyst. The oxidation occurs in gas-air mixtures below the lower explosive limit, and raises the temperature of the wire and its electrical resistance. The calorific value of gas-air mixtures at the lower explosive limit is approximately similar for most saturated hydrocarbons, and the response to a variety of gases is approximately the same. The resistance change is proportional to the gas concentration, and is detected electrically and used to operate a meter or sound an alarm.

The most reliable form of detection filament available at present is the pellistor, shown in Fig. 5. A platinum wire is embedded in a bead of alumina, the surface of which is subsequently coated with a palladium catalyst supported on thoria, to combine high sensitivity with good long-term stability. Two such pellistors, one deactivated, are mounted together as a pellistor-pair and used in a Wheatstone bridge circuit.

Pellistors may also be used in gas monitors, which must test for gas constantly over a period of many months without attention. The life of pellistors in spot-testing instruments is less important since the total hours of operation are few, but in the monitor, the life of pellistors is one of the most important features that influence the design.

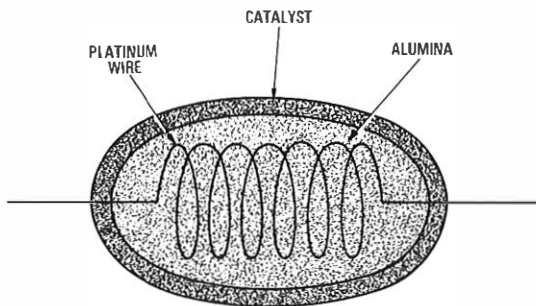

FIG. 5—Section through typical pellistor

Pellistor life is limited by 2 factors. It can fail by disconnection in a similar manner to any other heated filament; such failures are easily detected and monitors have equipment-failure alarms to bring such failures to notice. The more serious form of failure arises from the progressive loss of sensitivity to gas, caused by the poisoning or inhibiting effect of some atmospheric pollutants, especially some compounds of silicon, lead, phosphorus, bromine, chlorine and fluorine. The likelihood of this arising is unpredictable due to variations in local environments. Although the risk is likely to be greatest in industrial zones, tests have revealed a 30% loss of sensitivity after 1 year of continuous operation in a relatively "clean" zone.

Evidence suggests that the degree of poisoning is a function of the elapsed time for which the heated pellistor is exposed. Monitor systems have, therefore, been developed in which the pellistor-pair is energized for only a few seconds every few minutes; during this time, a test is made for the presence of gas. Tests at this frequency can be considered the equivalent of continuous monitoring. With this intermittent mode of operation, tests indicate no loss of sensitivity after more than 1 year of operation.

### AUTOMATIC GAS MONITOR

The monitor developed for the BPO is illustrated in Fig. 6, and its manner of operation is outlined in Fig. 7. It can be operated from any local power supply since it embodies a stabilized power converter.

The monitor consists of a control unit which is usually wall-mounted, and a detector head sited at the location where tests for gas are required. In the few cases where heavier-than-air gas mixtures are distributed (usually small butane or propane installations), the detector head is mounted at floor level. In all other cases, the head should be located clear of the wall and near the ceiling above the lead-in ducts. PVC-sheathed cable connects the detector head to the control unit and a length of 250 m is allowed with 0.9 mm conductors. Five conductors in the cable are used; 3 for connections to the pellistors, and 2 for a speaker circuit between the head and the control unit for initial setting-up and subsequent service visits. The detector head is certified safe for operation in Class 2B gases (methane and town gas) by the British Approval Service for Electrical Equipment and Flameproof Apparatus, and incorporates sintered-bronze flame traps. Flammable gases reach the pellistor surface by the process of diffusion, and a reaction time of 5 s is achieved. Carbon-cloth filters can be fitted to the detector head to reduce poisoning risks, but are not generally recommended since the sensitivity to some flammable gases is also reduced.

The monitor power system produces a stabilized voltage of 13 V, and the timing circuit energizes the detector head for 10 s in each 150 s period. During the first 8 s, the pellistors stabilize and a test for gas is made during the last 2 s. The

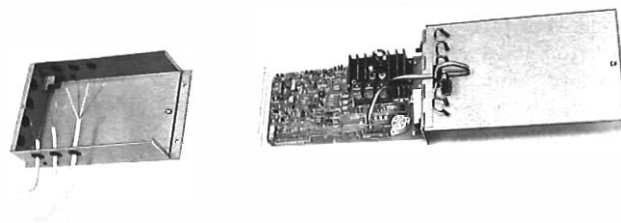
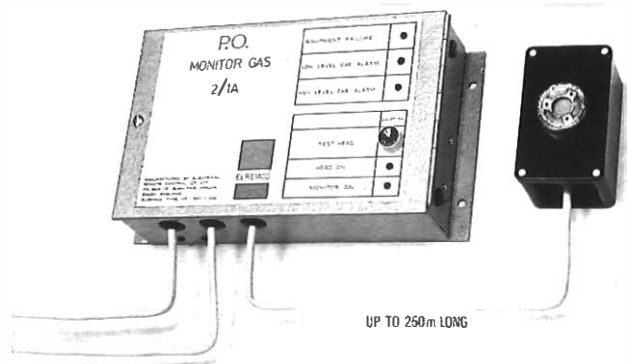

FIG. 6—BPO gas monitor

pellistors are used in a constant-current circuit so that the resistance unbalance in the presence of gas is evident as a potential difference which is used to switch an amplifier used as a signal detector. The amplifiers are pre-set for low-level and high-level gas alarms, corresponding to  $20\% \pm 2\%$  and  $50\% \pm 5\%$  lower explosive limit mixtures respectively. Both alarms lock permanently until they are restored manually. The low-level signal is extended as a prompt alarm to draw immediate attention to the presence of gas in the building, and should result in remedial action such as the dispersal of gas in external plant near the exchange by the removal of covers and use of blowers. The high-level alarm indicates that the gas concentration has reached potentially dangerous proportions, an explosion is possible, and the building should be evacuated. This can be achieved by sounding the building fire-alarm *evacuate* signal. Gas alarms can be displayed at building entrances to warn visitors.

The control unit is housed in a metal case, with a visual display of pilot and alarm lamps in the cover. Detection and timing circuit elements are solid-state and mounted on a single printed-circuit board. Three similar relays extend the low-level and high-level alarms and also an equipment-failure alarm, usually extended as a deferred alarm to draw the attention of the maintenance staff to a fault in the monitor.

Large installations can be protected by monitors having many separate detector heads linked to a single control unit. Some benefit in service facilities arises from the use of several single-headed monitors in these situations, however, since the range of spare components needed is reduced.

Servicing arrangements are simplified by the availability, as spare parts, of mounted pellistor-pairs and printed-circuit boards. To restore the monitor to working order, local maintenance staff will not need to understand fully the mode of operation of the equipment.

A manual routine test of the electrical operation of the monitor is made each month at the control unit by observing the reaction of the alarms to the depression of test buttons. A full live test of the monitor is made at 6-monthly intervals, when a 20% lower explosive limit gas-air mixture is passed



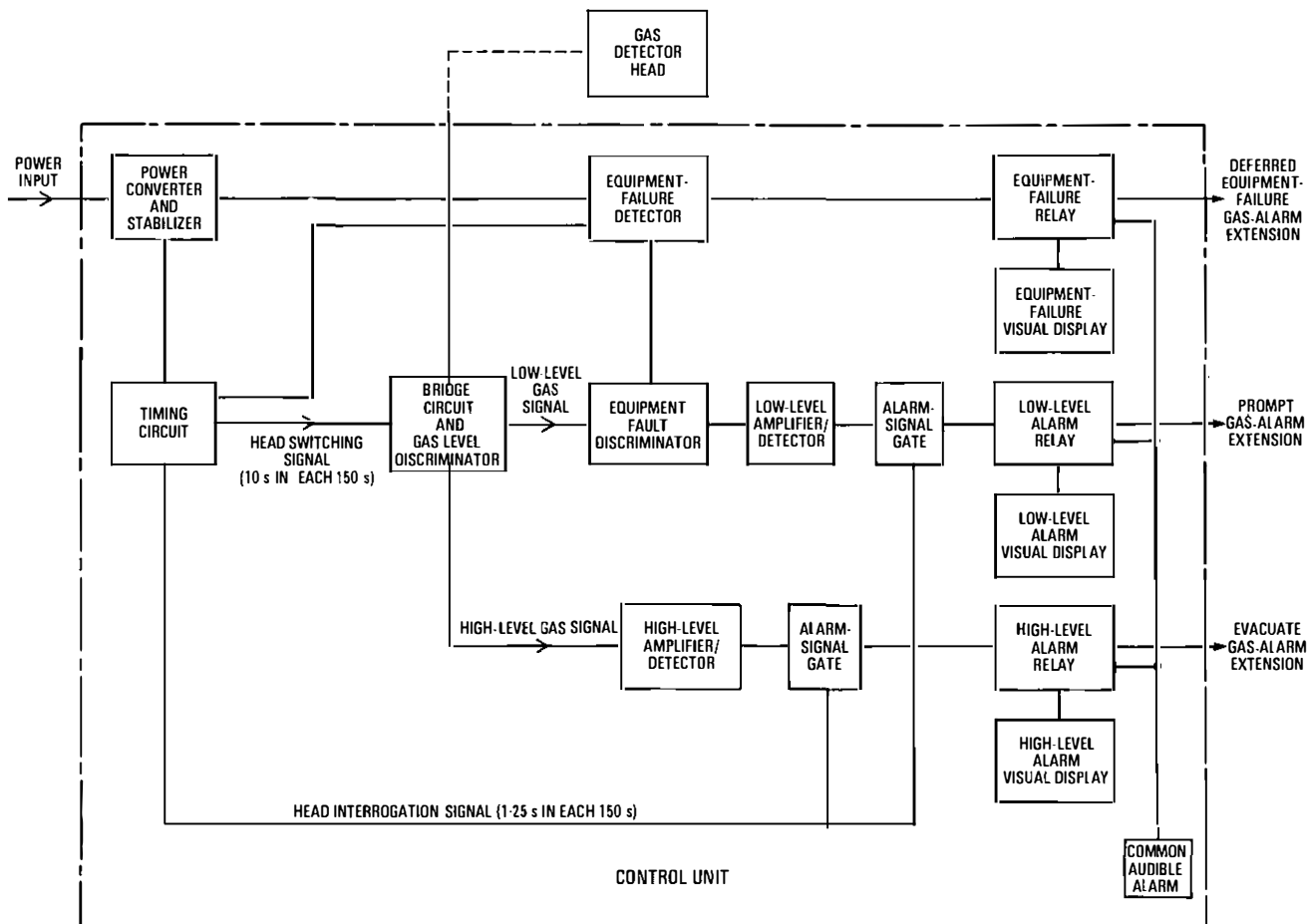

FIG. 7—Block diagram of BPO gas monitor

across the detector head. The speaker pair enables simultaneous observations and tests to be made at the detector head and the control unit; adjustments are made as necessary to the current through the pellistors and to the sensitivity settings. Records are maintained of adjustments found to be necessary, so that the progressive decline of components can be assessed.

In some special instances (for example, where no duct seal can be installed), it may be necessary to provide a detector head in a location prone to heavy condensation, such as an exchange manhole. To overcome any possible problems arising from condensation in these circumstances, the monitor can be operated in a continuous mode to dissipate more heat at the detector head. The use of detector heads in manholes presents problems of access for test purposes which should be fully appreciated before the system is installed. Pellistor life under continuous operation conditions is likely to be significantly shorter and regular replacement may be necessary.

### CONCLUSIONS

The provision of the complete protection system supported by reasonable maintenance efforts should give adequate safeguards to buildings, even in the event of an unfortunate coincidence when a serious gas leak arises at the time when one feature of the protection system is ineffective.

The system can be integrated at relatively low cost during the construction of new buildings, or the alteration of

existing ones. Some existing buildings present particular problems where solutions to ventilation or duct-sealing difficulties cannot easily be found. For this reason, retrospective action to protect all buildings will take some time to achieve and complete systems may not be installed in all cases. Judgment must be exercised in each case to determine an acceptable compromise, balancing the apparent level of risk with the cost of protection. A phased programme is being followed, enabling the more urgent cases to be dealt with first.

### ACKNOWLEDGEMENTS

The gas protection system described in this article has been evolved by the Protection of Operational Buildings against Gas Committee in Telecommunications Headquarters. The authors wish to thank contributors to the work of this Committee, especially colleagues in Operational Programming and Service Departments who developed the protection measures described. The valued assistance of the British Gas Corporation is also gratefully acknowledged.

### References

- 1 Regional Note. Explosion at Madeley UAX 13. *POEEJ*, Vol. 62, p. 65, Apr. 1969.
- 2 COLYER, J. O., THARBY, R., and SENIOR, R. C. Gases in Underground Plant and their Detection. *POEEJ*, Vol. 59, p. 80, July 1966.

# Amplifiers for Local-Line Wideband Distribution Systems

B. HAILES, B.SC., C.ENG., M.I.E.E., and D. P. NICHOLLS, B.SC.†

UDC 621.375:621.396.99

*Three types of amplifier are used in the distribution of television and frequency-modulated sound broadcast signals at very-high frequencies and ultra-high frequencies in British Post Office local-line wideband distribution systems. After outlining the main design parameters, this article considers the development of the amplifiers, some of the problems encountered and the techniques used.*

## INTRODUCTION

An article in an earlier issue of the *Journal*<sup>1</sup> described the overall concept of British Post Office (BPO) wideband systems distributing television and frequency-modulated sound broadcast signals at very-high frequencies (VHF) and ultra-high frequencies (UHF) in the local network. This article looks in greater detail at the development of the wideband line amplifiers for such a system, the problems encountered and the techniques used to overcome them.

The following 3 different types of amplifier are required in the system and are described in this article.

(a) *VHF Amplifiers* These are used on the trunk routes, which transmit the signals from the head-end of the system to the translators<sup>2</sup> on smaller systems, and from the main distribution centres to the translators on larger systems.

(b) *High-Frequency (HF)-VHF 2-way Amplifiers* These are used on large systems only, between the head-end of the system and the main distribution centres.

(c) *VHF-UHF Amplifiers* These are used on the distribution routes from the translator to the customer.

The VHF trunk amplifiers use what is relatively the most well-tried technology and, as such, have produced the least difficulties. The HF-VHF 2-way amplifiers are used only on very large systems, such as that being installed in Milton Keynes. They provide a 2-way link between the head-end of the system and the main distribution centres, from which the 1-way trunk routes are fed. Both the VHF and HF-VHF amplifiers are proprietary items.

The VHF-UHF distribution amplifiers required the most development work. No suitable proprietary amplifier was available since the emphasis throughout the world has been on VHF distribution. Moreover, the VHF-UHF amplifier development was less straightforward since it concerns the part of the spectrum between the lumped-component techniques of lower frequencies and the distributed techniques of microwave frequencies. The development was carried out both within the BPO, and by manufacturers with BPO liaison and co-operation.

## MAJOR PARAMETERS

There are 5 major parameters that must be considered in the design of wideband amplifiers. These are

- (a) gain/frequency response,
- (b) return-loss,

(c) noise figure,

(d) second-order intermodulation ratio, and

(e) cross-modulation ratio (third-order intermodulation).

## Gain/Frequency Response

The gain of all 3 types of amplifier is around 20 dB. It is technically desirable to have low-gain amplifiers, so that the differences in signal level are small enough to avoid both excessive noise and non-linear distortion. From an economic point of view, however, the amplifier spacings should be as great as possible to keep costs down. A gain of around 20 dB is a suitable compromise between these requirements.

The specified permissible variation in gain across the operating band is 0.5 dB for VHF amplifiers covering the frequency range 40–300 MHz, and 1.5 dB for VHF-UHF amplifiers covering the frequency range 40–860 MHz. Excessive variation in gain/frequency response over a number of amplifiers in tandem would cause unacceptable differences in the levels of the television channels at the customer's outlet. Variations in gain would also lead to the amplifiers being driven at higher or lower than the optimum level. Television channels that are transmitted at lower than the optimum level would suffer a worsening of their signal-to-noise ratio, while those transmitted above the optimum level would cause an increase in the non-linear distortion products.

## Return-Loss

The line amplifiers, and all of the equipment in the system, have nominal input and output impedances of 75 Ω. The accuracy of these impedances with respect to 75 Ω is measured by the return-loss. Poor return-losses cause multiple reflections on a system, giving rise to ghosting on the television pictures. A standing wave can also be set up at a resonant frequency between 2 points at which the return-loss is poor, thus causing a loss of power at that frequency.

In practice, satisfactory overall performance is achieved if the return-loss of VHF amplifiers is greater than 16 dB and that of VHF-UHF amplifiers is greater than 12 dB.

## Noise Figure

The specified noise figure of the amplifiers is around 10 dB at all frequencies. The noise contributions of amplifiers in tandem add on a power basis; that is, the noise figure of  $N$  identical amplifiers in tandem is  $10 \log_{10} N$  decibels worse than that of a single amplifier. Poor noise performance on a route of amplifiers reduces the signal-to-noise ratio of the television channels and increases the visibility of the familiar grained effect on the television pictures.

† Telecommunications Development Department, Telecommunications Headquarters

## Second-Order Intermodulation Ratio

In a telephony system, the speech signals are multiplexed in single-sideband suppressed-carrier form and there is a fairly uniform power density across the frequency band. The intermodulation products also occur uniformly across the band and can be treated as a form of noise. In a cable-television system, however, there is a smaller number of channels (up to 12) with most of the transmitted power in the carrier frequencies ( $f$ ). The second-order intermodulation products ( $f_1 - f_2$  and  $f_1 + f_2$ ) of these carriers therefore take the form of discrete products.<sup>3</sup> If these products occur within allocated television channels, they cause interference in the form of patterning.

The second-order intermodulation ratio expresses, in decibels, the difference in level between the transmitted signals and the unwanted second-order signals. At output levels of +30 dBmV† per channel, the VHF amplifiers have a specified second-order intermodulation ratio of 76 dB, while for the VHF-UHF amplifiers, the ratio is 55 dB.

## Cross-Modulation Ratio

In general, the third-order distortion products are of lower level than the second-order products. There is, however, one particular form of third-order product ( $f_1 \pm f_2 \pm f_3$ ) that is of great importance. This occurs when 2 of the frequencies under consideration are television carriers ( $f_1$  and  $f_2$ ), and the third frequency is the sideband information on one of these carriers ( $f_2 \pm \Delta f$ ). One of the triple beats involving these frequencies occurs at  $f_1 - f_2 + (f_2 \pm \Delta f)$ ; that is, at  $f_1 \pm \Delta f$ . Thus, the sideband information from carrier frequency  $f_2$  is transferred to carrier frequency  $f_1$ . This effect is known as *cross-modulation*, and for television carriers takes the form of either a faint superimposition of one picture on the other for synchronous channels, or a herringbone pattern running through the picture for asynchronous channels.

The cross-modulation ratio expresses, in decibels, the ratio of wanted to unwanted modulation occurring on a carrier. At output levels of +30 dBmV per channel, the VHF amplifiers have a specified cross-modulation ratio of 97 dB and, for the VHF-UHF amplifiers, the ratio is 77 dB. The second-order and third-order distortion products of a number of amplifiers in tandem add on a voltage basis; that is, the distortion ratios of  $N$  amplifiers in tandem are  $20 \log_{10} N$  decibels worse than those of a single amplifier. This, together with the rule for noise figure quoted earlier, is used to determine the maximum number of amplifiers in tandem and the operating levels of a route of amplifiers.

## VHF AMPLIFIERS

The present VHF amplifiers operate over the frequency range 40–270 MHz. Amplification is achieved by 4 discrete push-pull transistor stages giving a maximum gain of 25 dB, with gain control by means of both plug-in and continuously-variable attenuators. A block diagram of a VHF amplifier is shown in Fig. 1(a). To compensate for the frequency-dependent attenuation of the system cables, which is proportional to the square root of the frequency, the amplifiers have 3 dB or 9 dB of fixed equalization between 40 MHz and 270 MHz, with a further 7 dB of variable equalization available via a potentiometer.

The normal operating level is +33 dBmV per television channel at the output of the amplifier. Signal levels can be

† dBmV is an abbreviation for decibels relative to the power dissipated by a reference voltage of 1 mV r.m.s. applied to a specified load. For local-line wideband distribution systems, the load is 75  $\Omega$ , equal to the characteristic impedance of the system. Signal strengths expressed in dBmV thus measure the power in decibels relative to 1 mV applied to a 75  $\Omega$  load. In a 75  $\Omega$  system, +30 dBmV is approximately equal to -19 dB relative to 1 mW (dBm)

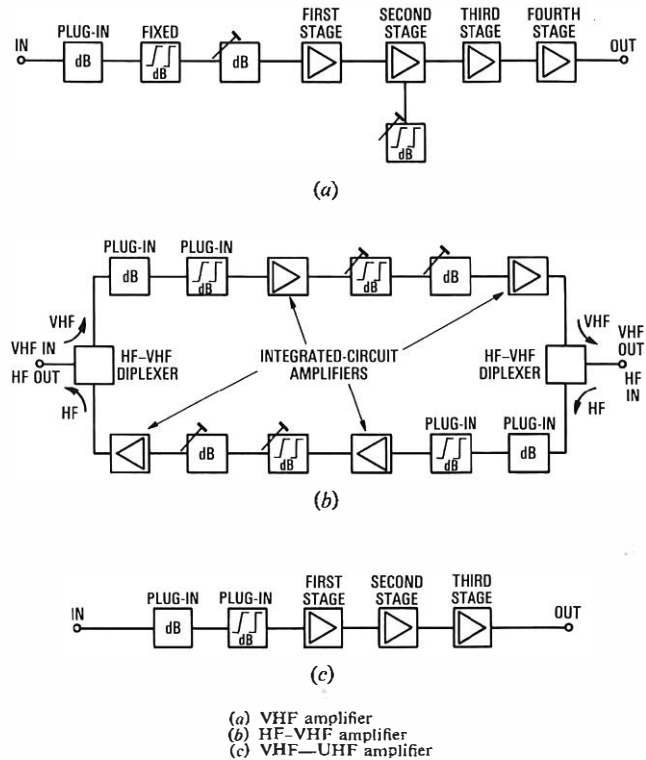

FIG. 1—Block diagrams of the amplifiers

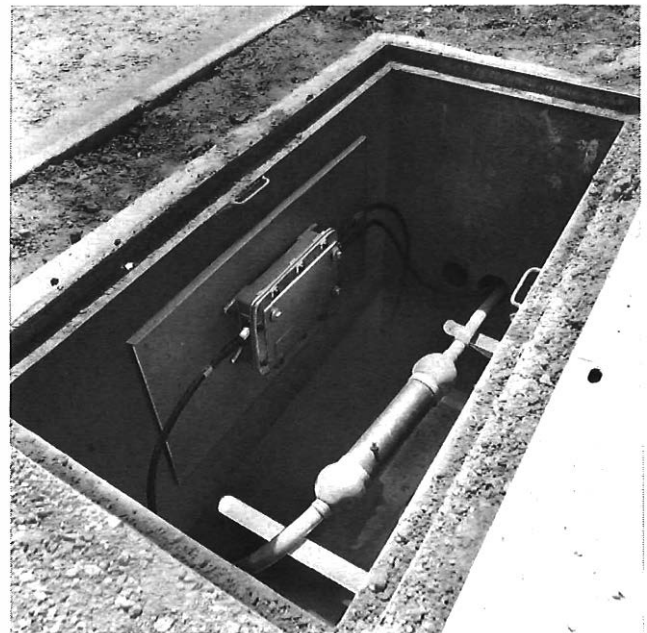

FIG. 2—VHF amplifier sharing footway box with telephone cable joint

monitored at both the input and output of the amplifier through monitor points having a level 26 dB lower than the signal level.

The amplifiers are line powered over the system by a direct voltage in the range 30–55 V. This is regulated to 24 V d.c. within the amplifier. Each amplifier compensates for the loss of about 0.5 km of the 16.5 mm diameter coaxial cable used for VHF routes. Up to 16 amplifiers can be used in tandem, giving a maximum route length of 8 km.

The VHF amplifiers are housed in die-cast aluminium cases and are installed either in cross-connexion cabinets or in footway boxes. Fig. 2 shows a VHF amplifier sharing a footway box with a telephone cable joint.

## HF-VHF AMPLIFIERS

On large systems, higher performance VHF amplifiers are required to cover the longer distances between the head-end of the system and the main distribution centres; up to 40 amplifiers in tandem could be used, giving a maximum route length of 20 km with 16.5 mm diameter cable. These routes may also require one or more channels in the reverse direction to connect programme sources to the head end of the system. Therefore, the amplifiers on these routes transmit signals in the frequency range 50–300 MHz in the forward direction, with the option of a plug-in reverse-direction amplifier covering the frequency range 5–30 MHz. Transmission in the 2 directions is over a single cable.

Within the amplifiers, the forward and reverse frequencies are filtered and amplified separately. Amplification is achieved by thick-film linear integrated circuits. The forward and reverse paths have independent gain control and equalization. A block diagram is shown in Fig. 1(b).

The amplifiers are line powered by an alternating voltage in the range 40–60 V. This is rectified and regulated within the amplifiers to provide a 24 V d.c. supply.

The amplifiers are constructed on a modular basis, the various modules being plugged into a backplate which is mounted in a die-cast aluminium case. The amplifiers are installed in cross-connexion cabinets.

## VHF-UHF AMPLIFIERS

### History

The first local-line wideband distribution system involving VHF trunk routes and a final distribution to customers over the complete VHF-UHF television broadcast spectrum (40–860 MHz) was introduced at Milton Keynes in 1972. No suitable distribution amplifier was commercially available at that time. The main reason for this was that manufacturers had previously catered for relatively small distribution systems, which did not call for the higher amplifier performance needed in a large hybrid system. However, it was believed that significant improvements in performance could be achieved. For example, there were the advances in device technology with very linear transistors, having cut-off frequencies of about 5 GHz, becoming available. New techniques could be used, such as microstrip instead of coaxial interconnexions within the amplifier, and advantage could be taken of powerful new computer programmes specifically catering for high-frequency design work.

The requirement for a 40–860 MHz distribution amplifier was initially expressed in March 1972, and the first amplifier was installed at Milton Keynes in November of that year. This first amplifier was developed by the BPO as an interim solution. It involved re-engineering the printed-circuit-board modules from a proprietary amplifier into a BPO-designed housing, to reduce the amplifier size and improve its gain/frequency response. The reduction in size was necessary to allow accommodation of the amplifiers in wall boxes at the customers' premises, as shown in Fig. 3. An additional advantage proved to be a substantial reduction in cost. Single-output and double-output versions of this amplifier were developed.

The second-generation amplifiers were made to a BPO performance specification, involving close liaison with manufacturers. Various advantages accrued from the use of the more modern technology available; there was a further reduction in size of the double-output version, an improvement in all electrical performance parameters, greater reliability, greater ease of installation and maintenance, and a further reduction in cost.

A third-generation amplifier has now been developed by the BPO. As yet designed for only single-output operation, the amplifier is much smaller than its predecessors, generates less distortion, and is easier to install and maintain. A reduction



FIG. 3—First-generation VHF-UHF amplifiers in wall box at customer's premises



FIG. 4—Third-generation VHF-UHF amplifier in Sleeve No. 31A

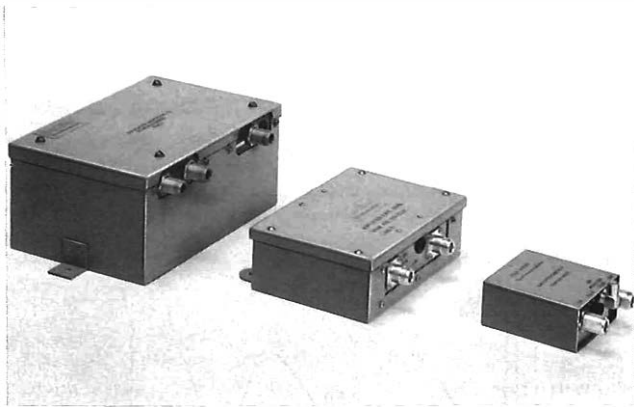

FIG. 5—Three generations of VHF-UHF amplifiers

in price is expected, and no trade-off of other parameters is involved. The amplifier is small enough to fit into a Sleeve No. 31A (see Fig. 4). Thus, for the first time, it should be possible to install waterproof distribution amplifiers in foot-way boxes. Fig. 5 shows the reduction in size achieved in the 3 generations of amplifier. At present, up to 3 distribution amplifiers can be used in tandem.

### Mechanical and Electrical Design

Distribution amplifiers are usually mounted in cabinets or wall boxes which provide a sheltered environment. For such locations, a sheet-metal case is used instead of the more expensive die-cast water-resistant cases of underground VHF amplifiers. This also renders the amplifier interior more accessible. Nevertheless, a completely waterproof design is desirable and this has been achieved with the third-generation amplifier. The amplifiers are line-powered by a direct voltage of 24 V. A strapping facility allows the amplifier to be powered from the input or output. No undesirable corrosion effects attributable to the use of d.c. have become apparent in line equipment. The more recent amplifiers have been designed to be tolerant of supply-voltage variations by stabilizing the transistor operating points through heavy d.c. feedback.

Gain control cannot be achieved by using simple potentiometer attenuators as these give rise to mismatch problems which become worse at higher frequencies; nor does the technique of altering transistor gain by varying the d.c. bias prove satisfactory. Plug-in attenuators and equalizers are therefore used. A block diagram of this type of amplifier is given in Fig. 1(c).

To achieve the best electrical characteristics, the following options are open, in principle, to the designer of a local-line wideband television distribution amplifier.

(a) *Choice of Transistor Configuration* The common-emitter configuration is widely used because it provides high gain and wide frequency range. Good noise performance could be achieved by common-base working, but this creates considerable matching problems.

(b) *Negative Feedback* Applied to a single stage, negative feedback can be used to tailor the gain/frequency response, achieve correct input and output impedances, and reduce noise and non-linear distortion. Attempts to apply negative feedback over more than one stage will almost certainly result in instability because of the large variation in loop phase/loop gain across the frequency range.

(c) *Push-Pull Operation* This is used extensively in proprietary VHF amplifiers to reduce greatly even-order distortion. Odd-order distortion is also reduced, because each transistor is working at half the power level of its single-ended counterpart. However, at frequencies above 300 MHz,

it becomes increasingly difficult to secure correct phase tracking between the 2 halves of a push-pull pair, and so this technique is not used for distribution amplifiers.

(d) *Split-Band Operation* This involves splitting the frequency spectrum into 2 bands by means of a low-pass and a high-pass filter, amplifying the 2 frequency bands in separate amplifiers, and then combining them, again using filters. Cross-modulation performance is enhanced, as each amplifier carries fewer channels, and the output filter blocks some second-order distortion products. BPO amplifiers do not use this technique because of its expense and the loss of the filter cross-over band.

(e) *Channelized Amplification* It is possible to carry the splitting of the spectrum, described above, to its logical conclusion and amplify each channel separately. However, it is difficult to achieve the necessary filter selectivity and filter pass-band flatness. An additional problem is that high-selectivity filters can cause excessive group-delay distortion; if a number of amplifiers were connected in tandem, this distortion would displace the colour information relative to the black-and-white information in a television picture.

The classical concepts of lumped-element theory, such as negative feedback, become more difficult to apply at high frequencies. Manufacturers are now beginning to specify high-frequency transistors in terms of their 2-port parameters. *S*-parameters are usually quoted in preference to the more familiar *h*-parameters. This is because *S*-parameters are easier to measure at high frequencies, and they are directly related to the input and output reflection coefficients and forward and reverse gains; these are meaningful concepts to the design engineer. They also lend themselves to graphical design and analysis of amplifier stages. Computer programmes are now available to perform this analysis much more quickly and accurately. Some programmes can optimize circuit response by varying selected component values until the best overall performance is achieved.

At VHF-UHF frequencies, it is often necessary to treat components not only as lumped elements, but also to apply transmission-line theory as wavelengths are so short; microwave concepts must also be used because electromagnetic fields are significant. Some of these ideas are illustrated by the examples given below.

### Stray Capacitance and Inductance

Every component has a stray capacitance between its terminals. This capacitance may be distributed along the length of the component. In addition, there may be appreciable stray capacitances from the component to earth, or to other components. These can be minimized by suitable circuit layout; a capacitance of 2 pF has a reactance of less than 100  $\Omega$  at 860 MHz.

Another form of parasitic component is self-inductance. An isolated wire has an inductance of approximately 1 nH/mm. Therefore, a 5 mm lead at each end of a resistor together add about 50  $\Omega$  to the inductive reactance of the resistor at 860 MHz. Unwanted inductance can be reduced by using shorter components, keeping leads as short as possible, or by wiring components in parallel. A further reduction in the effect of self-inductance can be achieved by positioning a component so that stray shunt capacitance progressively reduces its impedance as self-inductance adds to its impedance. The circuit layout in Fig. 6 illustrates the application of these methods in the third-generation amplifier.

### Skin Effect

At high frequencies, currents travel in only the outer surfaces of conductors. This leads to problems, in particular with earthing inside the amplifier, because the high-frequency earth currents may travel over much longer paths than would

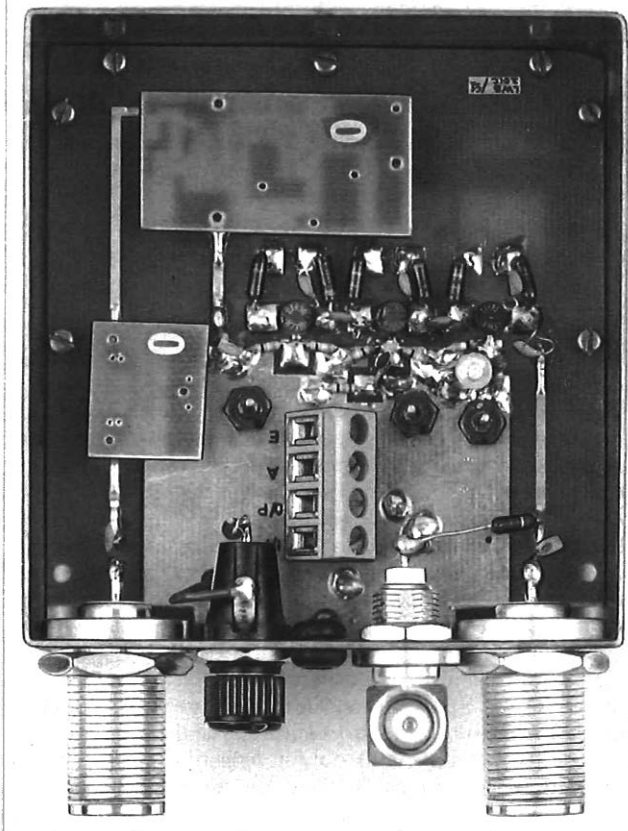
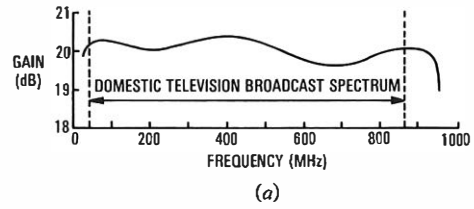
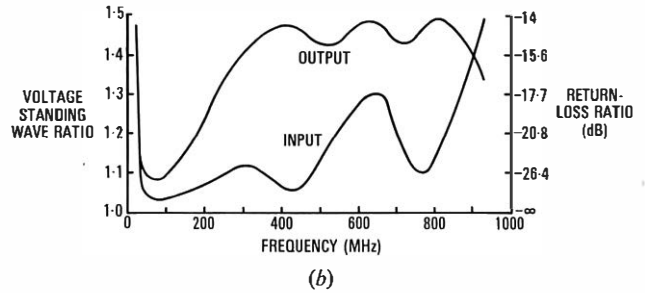

FIG. 6—Internal view of third-generation VHF-UHF amplifier



(a)



(b)

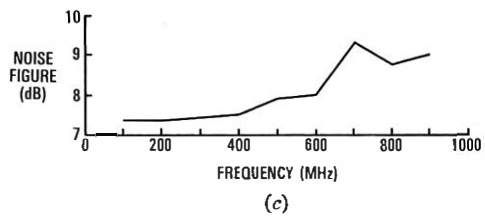

(c)

FIG. 7—Performance of third-generation VHF-UHF amplifier

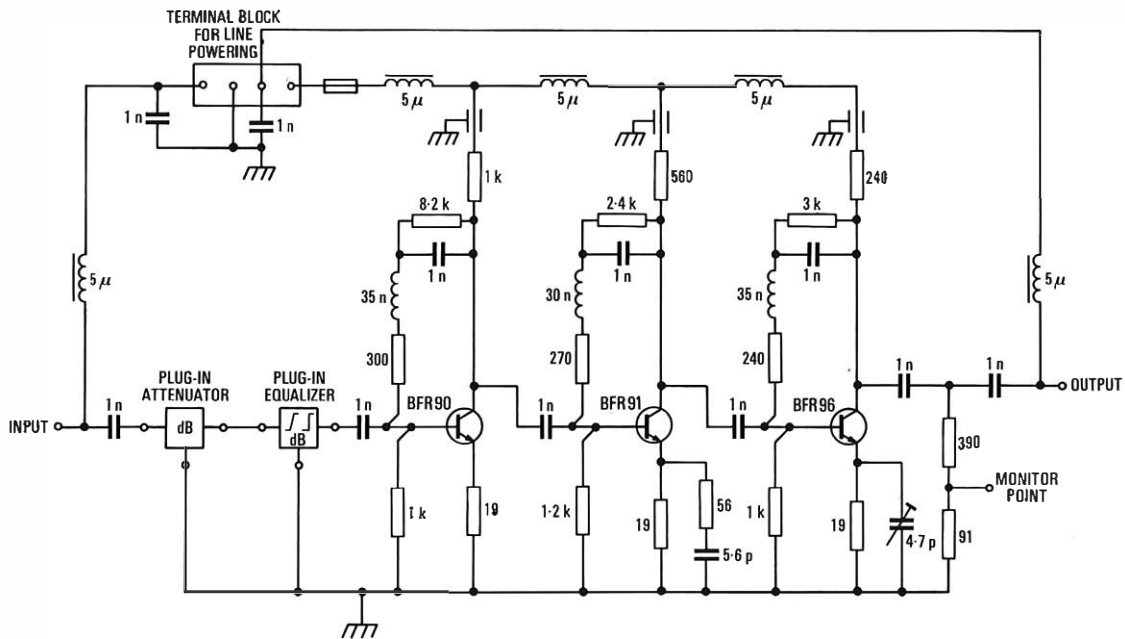

FIG. 8—Circuit diagram of third-generation VHF-UHF amplifier

low-frequency currents. Resistance can thus be introduced into the earth circuit and this can cause feedback between stages. Furthermore, the longer earth-current path may upset the electromagnetic field pattern, for example, at the interface between input connector and printed-circuit board, creating a mismatch at that point.

#### Tuned-Cavity Effects

Quite small crevices are capable of coupling to electro-

magnetic fields inside the amplifier and causing resonances, the effect normally appearing as a very sharp reduction or increase in gain at a particular frequency. Typical causes are loose or poorly-earthed lids, or a narrow gap between the edge of a printed-circuit board and earthed metal-work.

#### Mismatch Losses

Interconnexions between amplifier stages separated by distances of more than a few centimetres have traditionally

been made with coaxial cable. However, the characteristic impedance of the cable is not preserved at its interface with a printed-circuit board and the resultant mismatch affects the gain/frequency response. To overcome this, microstrip techniques are now used for internal amplifier connexions. Microstrip transmission line is formed by a copper strip etched on one side of the printed-circuit board with an earth-plane on the other. The characteristic impedance of the line is determined by its capacitance and inductance per unit length, and these quantities depend upon the strip width, board thickness, and the relative permittivity of the board material.

### Performance

The most recently developed distribution amplifier is not yet in production. However, the performance achieved by prototypes is shown in Fig. 7; the circuit diagram is given in Fig. 8.

Fig. 7(a) shows the typical gain/frequency response. In earlier amplifiers, the response was set during manufacture by adjusting variable resistors and capacitors, and altering inductance values by spacing the turns of coils. Up to a dozen variable components were involved; alignment was a time-consuming and costly process. More modern technology allows a better gain/frequency response to be achieved using only one select-on-test or variable component; in this case, a variable feedback capacitor.

Fig. 7(c) shows the noise performance of the amplifier. The transistors used for the input stage are capable of giving noise figures of about 2.5 dB, but this is under optimum conditions of bias and source impedance. In practice, the biasing must be chosen to provide good linearity and the source impedance presented to the transistor must be designed to give good matching; hence the higher overall noise figure of around 10 dB.

Cross-modulation ratios of 90 dB are attainable, assuming 2 channels each at a level of +30 dBmV at the amplifier output. The current-generation amplifier is specified as better than 77 dB.

### FUTURE DEVELOPMENTS

At present, thick-film linear integrated circuits are used only in the HF-VHF amplifiers. The current VHF trunk amplifiers use discrete components since they were designed before the integrated circuits became available, but any future VHF amplifiers will use integrated circuits.

For VHF-UHF amplifiers, there is not yet a suitable integrated circuit available. Those integrated circuits that do operate at these frequencies give poorer performance than can be achieved using discrete components. However, it is expected that the performance of integrated circuits will continue to improve and that their use will eventually supersede discrete components across the complete VHF-UHF television bands.

### ACKNOWLEDGEMENTS

The authors wish to thank their colleagues in the Line and Radio Systems Division of the Telecommunications Development Department for their assistance both in the development work and in the preparation of this article.

### References

- 1 AXE, G. A. The Development of Dual-Cable Systems for New Towns. *POEEJ*, Vol. 69, p. 48, Apr. 1976.
- 2 BARLOW, G. H., HAWKES, J. B., and ROBBINS, C. H. Translation Equipment for British Post Office Local-Line Wideband Systems. *POEEJ*, Vol. 69, p. 51, Apr. 1976.
- 3 SIMONS, K. A. The Decibel Relationships between Amplifier Distortion Products. *Proc. IEEE*, Vol. 58, No. 7, p. 1071, July 1970.

---

## Book Review

*Handbook of Electronic Circuits*. G. J. Scoles. Ellis Horwood Ltd., distributed by John Wiley & Sons Ltd. xiv + 370 pp. 258 ill. £13.50.

In the introduction to this book, the author lists the various kinds of reader he hopes will be assisted by the book. These range from workers in fields other than electronics to professional designers of electronic equipment.

The book offers a range of over 200 basic circuits, at least some of which will be novel to most readers. The layout is clear, and ample references are given for those who wish to read further. The author points out that tubes, bipolar transistors and field-effect transistors should each be considered for a particular circuit, and that the transistor is not always the only practical device to use in every circuit application. To bring the point home, he includes a code in the title of appropriate sections indicating which of the 3 devices can be used in the circuits described. Often, the circuits are suitable for tubes or either type of transistor.

Sufficient explanation of the circuit is given to enable the reader to appreciate the operation and field of application, but, although typical values for some of the components are included in the text, a reasonable knowledge of electronic techniques would be required to build a practical unit.

Circuits for computers and digital equipment are omitted, and so are integrated circuits, the book being concerned mainly with basic circuits that can be built up easily and that will work together.

The author gives a simple method of recognizing which symbols on a diagram represent a pnp transistor and which an npn transistor, but does not mention that this only applies if the symbol is drawn with the collector uppermost. The first example of a circuit using both types of transistor does not follow this drawing practice, and the *aide memoire* would, therefore, confuse rather than help a newcomer to transistor circuitry.

It is regrettable that the symbol used for a bipolar transistor in 2 chapters is different from that given in the British Standards Institution's BS 3939. This is quite deliberate, and the reasons are pointed out in Chapter 2. The symbols in BS 3939 were arrived at after considerable national and international discussion, and whilst the argument for the alternative symbol is still valid, it seems unnecessary to revive it again. Also, as the correct symbol is used elsewhere in the book, the alternative can only confuse the reader.

It is a pity that the cost of the book is rather high, as this will probably limit its readership and deny a useful guide to those who would benefit most.

D. P.

# Experimental Packet-Switched Service: The Customers and their Packet Terminals

M. J. BURGESS and J. A. LOCKWOOD, B.SC., M.SC.(ENG.)†

UDC 621.394.4:681.327.8

*This article deals with the involvement of customers in the Experimental Packet-Switched Service (EPSS). A list of the participants is given, and their contribution to shaping the service is mentioned. The protocol levels defined by the customers to complement the British Post Office's network protocol levels are described. The article goes on to examine the problems of interfacing a computer system with the EPSS, and gives some of the solutions adopted by customers.*

## INTRODUCTION

The Experimental Packet-Switched Service (EPSS), which is now being brought into service, involves approximately 40 users. Table 1 is a list of organizations that, at 1 March 1976, had stated their intention to participate in the EPSS. From the outset, the British Post Office (BPO) decided to involve customers in the experiment to ensure a full technical and commercial evaluation of packet switching for both data processing and data communication. Judgement of the service's commercial viability must be related to the experience of customers in widely differing fields, such as commerce, government, research, and computer and terminal provision; it must take into account the effect of experience on terminal design and operational facilities, as well as the economic benefits. To this end, one of the main marketing objectives has already been achieved, since the packet-port capacity of the EPSS is virtually exhausted and the range of types of participant spans the required activities.

† Telecommunications Marketing Department, Telecommunications Headquarters

A condition of participation is that each customer must have at least one packet terminal, and this article describes the alternative approaches being adopted by customers to the design of their packet-interfacing arrangements and the factors that have to be taken into account. The degree of each customer's involvement in the EPSS varies. Some have full-time staff committed to the project, and others are relying almost entirely on proprietary systems. Considerable manpower resources and a great deal of hardware have been devoted to customers' systems; present estimates put the customers' total investment at greater than £1M. With this level of customer investment, and recognizing the technical complexity of interfacing with an experimental service of this type, the BPO has a responsibility to provide suitable facilities to ensure that customers' plans proceed smoothly, and to make available the necessary expertise to resolve the many technical, operational and procedural problems they meet. This has been done by the establishment of the EPSS Liaison Group and 3 Study Groups, the latter having been formed to investigate particular areas of technical interest. The work of these groups has been of major value in this joint project between the BPO, the computer industry and the customers.

TABLE 1  
Participants in the EPSS

National Physical Laboratory Computer-Aided Design Centre National Engineering Laboratory The Rutherford High-Energy Laboratory Joseph Lucas Ltd. Burroughs Machines Ltd. Sperry Univac Ltd. ICL Sperry Univac: London Development Centre Ferranti Ltd. GEC Computers Ltd. Midland Bank Ltd. National Computing Centre Ltd. Hatfield Polytechnic North Staffordshire Polytechnic University of Glasgow Queen Mary College University College of London Tymshare UK Ltd. Agricultural Research Council Taskmaster Computing Systems Edinburgh Regional Computing Centre University of Nottingham	University of Oxford Manchester Regional Computing Centre Civil Service Department SCICON Computer Bureau I.P. Sharp Associates Ltd. Arbat Consultants Ltd. Atlas Computer Laboratory Daresbury Laboratory BPO Data Processing Service City of London Polytechnic Atomic Energy Research Establishment, Harwell University of Cambridge Logica Ltd. Control Data Corporation F. W. Woolworth Ltd. University of Newcastle-upon-Tyne Paisley College of Technology University of Sheffield University of St. Andrews University of Essex University of London Computer Centre Ministry of Defence: Signals Research and Development Establishment
---	--



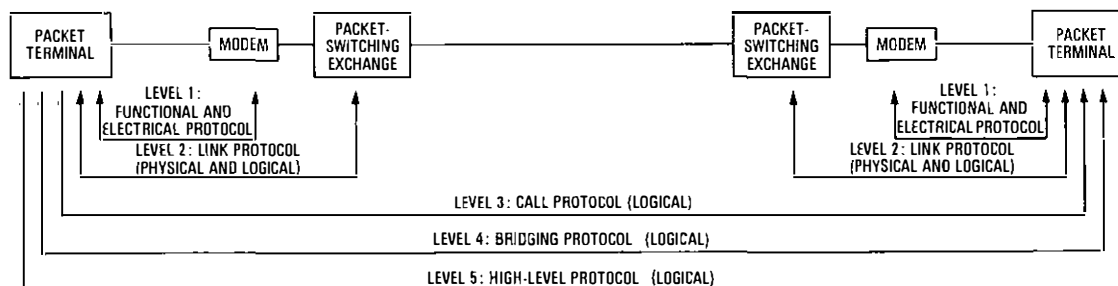

FIG. 1—Protocol levels

## PROTOCOL LEVELS

Typically, a packet terminal is a small-scale computer, or *minicomputer*, acting as a remote job-entry (RJE) terminal† or as the interface to a front-end processor (FEP). It is responsible for receiving and transmitting packets in accordance with rules and procedures, or *protocols*, laid down by the BPO. These protocols, which specify the packet-interfacing arrangements, can be divided into a number of levels that can be dealt with independently for the purposes of packet-terminal design.

The BPO specifies 3 levels of protocol, and these are described below.

(a) *Level 1* This is a functional and electrical protocol relating to the operation of the modem interface. It is relatively trivial and poses no special design problems.

(b) *Level 2* This is a transmission or link protocol relating to the transport of packets between the terminal and the packet-switching exchange (PSE). Two options are available: standard or simplified transmission protocol.<sup>1</sup>

(c) *Level 3* This is a virtual-call<sup>2</sup> protocol relating to the exchange of packets between users. (In this context, a user can be a process within a computer.)

Two further levels of protocol have been defined by the customers. Their use by participants is not mandatory, although the use of other versions can restrict intercommunication. These levels are described below.

(a) *Level 4* This is a bridging protocol, and is needed to drive the virtual-call protocol.

(b) *Level 5* These are higher-level protocols which provide a standard set of commands; for example, for file-transfer and job-transfer operations.\*

The protocol levels are illustrated in Fig. 1, and are described in more detail below.

### Level 1 Protocol

Level 1 protocol specifies the operation of the interface between the modem and the customer's equipment in electrical and functional terms. In general, the modems used for the EPSS have standard interfaces to the International Telegraph and Telephone Consultative Committee (CCITT) V-series recommendations, and matching hardware interfaces are commonly available on computer and terminal equipment. Therefore, this level raises no particular problems and is not discussed further.

† An RJE terminal is a device at which a job can be entered for processing at a remote computer

\* A job is a unit of work for a computer; a file is an organized collection of records. *Job transfer* and *file transfer* relate to the transfer of a job or file from one computer to another. The job-transfer protocol defines the control information that is transferred with a job. The file-transfer protocol informs the receiving computer about parameters such as the size of the file being transferred

### Level 2 Protocol

Level 2 protocol is concerned with the transport of packets between the packet terminal and the PSE. It deals with

- (a) error detection, using cyclic-redundancy-checking procedures specified by the CCITT,<sup>3</sup>
- (b) the return of appropriate ACK and NAK acknowledgement signals<sup>1</sup> after the receipt of a packet,
- (c) setting and checking the packet-terminal-to-PSE link sequence number,<sup>1</sup> and using this information to discard duplicate packets, and
- (d) maintaining byte synchronism. (In the idle state, contiguous streams of idle bytes are transmitted in both directions to maintain byte synchronism.)

There are 2 options at level 2: the standard or the simplified protocol, both of which are byte synchronous. The standard protocol imposes very rigorous timing constraints on the acknowledgement of packets, which suggests the need for specialized hardware. The simplified protocol is easier to implement because the timing of the acknowledgement procedures is less critical and no special hardware is needed. However, the less rigorous acknowledgement procedures do result in degradation of the throughput.

### Level 3 Protocol

A virtual call can be defined as a logical link between 2 computer processes, and this definition is appropriate to packet switching, where there is no physical call routed over a dedicated circuit. Inherent in the virtual-call mechanism is the sequencing of packets and the control of packet flow.

A virtual-call network, like the EPSS, takes responsibility for sequencing packets and controlling their flow, and it does this with level 3 protocol. A call record is established in the originating and destination PSEs, which thereby control these activities. Therefore, the packet terminal has to obey the network's virtual-call rules, and also has to follow appropriate procedures for

- (a) the setting-up of calls,
- (b) the subsequent exchange of packets,
- (c) clearing, and
- (d) resetting.

If these procedures are operated incorrectly, the network responds with network information packets<sup>1</sup> that indicate the nature of the error.

### Level 4 Protocol

Whereas level 3 protocol specifies the functions that allow a virtual call to take place, level 4 protocol is concerned with the manipulation of these functions. This, in turn, depends on communication between this level and the application level above. (In this context, *application* means a general application such as file transfer or job transfer.)

Level 4, known as the *bridging-protocol level* or *the bridge*, was specified by EPSS participants within the member-

ship of Study Group 3. While it is not mandatory to use this protocol, many customers will do so, and general intercommunication will be restricted without its use. The objects of the bridging protocol are that

- (a) it should conceal the particular details of the EPSS, so as to provide a network-independent interface,
- (b) it should provide facilities to support all the functions required by the application, and
- (c) it should be as simple as possible.

To achieve the third object, it is necessary to avoid sophisticated facilities such as data compression and submultiplexing. It is also necessary to minimize the duplication of functions that occur at other levels. Hence, it was decided that an activity should be undertaken at this level only if it is dependent on the EPSS, or if the necessary information is not available to higher levels. For example, flow control could be handled at the application level, but the function of passing the information to other levels is more onerous than dealing with it at the bridging level.

The bridge interacts with the application software to achieve the establishment of a virtual call, the exchange of data, and the termination of the virtual call. The manner in which this works can be illustrated by examining the setting-up phase of a call, which is shown diagrammatically in Fig. 2.

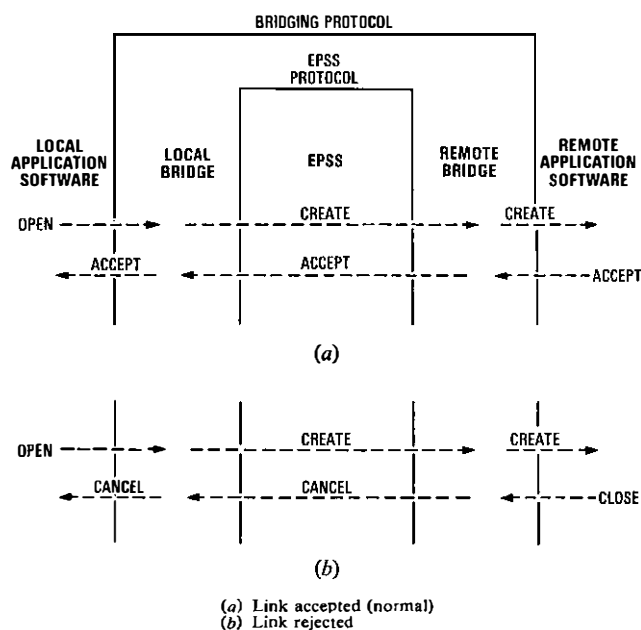

FIG. 2—Establishment of a link

The application software addresses the bridge using an OPEN statement, requesting the bridge to establish a call, and passing the necessary information to the bridge. The bridge sends a CREATE message, using a call-originating packet,<sup>1</sup> to the remote bridge. The remote bridge signals the CREATE state to the application level. Typically, the bridge interacts with a "listening state" within the application software, which chooses an application process to handle the call. In such a case, the application software sends an ACCEPT statement to the bridge. The bridge then sends an ACCEPT message (that is, a first-response packet<sup>1</sup>) to the originating bridge, and the originating bridge in turn signals the ACCEPT state to the originating application software.

If the remote application software cannot handle the request (Fig. 2 (b)), it sends a CLOSE statement to its bridge, which in turn sends a CANCEL message (that is, a first-response packet marked *clear*) to the originating bridge. The originating bridge signals the CANCEL state to the originating application software.

In addition to the basic control functions mentioned above, the bridge can also

- (a) carry out error-recovery procedures, including reacting to network information packets,
- (b) interrupt data to initiate remote resetting or error-recovery procedures,
- (c) force the delivery of transmitted data, and
- (d) control the data flow to prevent the capacity of the receiving terminal being exceeded.

The present bridging protocol attempts to achieve the efficient use of the EPSS's facilities. It will, no doubt, be subject to further development after operational experience has been gained.

### Level 5 Protocols

The higher-level protocols, which are specified by Study Group 2, provide command structures for file transfer, job transfer and character-terminal<sup>4</sup> support. They are network-independent, and could also be used in private-circuit, or circuit-switched data-communication environments. Their aim is to facilitate communication between machines of like and unlike manufacture which, at present, have different command structures. Without them, the usefulness of a switched network is considerably reduced because of the inability of different machines to communicate with each other. It is not a requirement of participation in the EPSS to follow these particular protocols when constructing a packet terminal, although a number of participants plan to do so.

### Advantages of Separate Levels

The separation of protocols into distinct functional levels is fundamental to the design of a packet terminal. Each level can be made independent of the adjacent levels by careful specification of the interfaces. This approach provides considerable benefits in an experimental environment, since it allows modifications to be made within one level without the need to make parallel modifications in other levels. It is also a convenient method of dividing the design problems into manageable parts.

### INTERFACING WITH EXISTING COMPUTER SYSTEMS

The problems of adapting a conventional computer system to the EPSS are most easily illustrated by examining the conversion of the communications element of a conventional on-line system. Fig. 3(a) shows a star network of "intelligent" terminals connected to a computer centre by private circuits operating at 2.4 kbit/s. Conversion involves the removal of the existing communication lines, their replacement by communication lines to PSEs, giving the network configuration shown in Fig. 3(b), and the construction of packet interfaces at the terminals and computer centre.

### THE COMPUTER CENTRE INTERFACE

To determine how a computer centre can be adapted to interface with a packet-switched network, it is useful to consider what communication functions are handled by the mainframe and the FEP.

#### Mainframe

The central processing unit of a computer system is often referred to as the *mainframe*. The provision of an FEP relieves the mainframe of routine communication functions. In general, the more sophisticated the FEP, the less the communication work carried out by the mainframe. The mainframe provides software support for the FEP by means of generalized input/output control routines. These routines

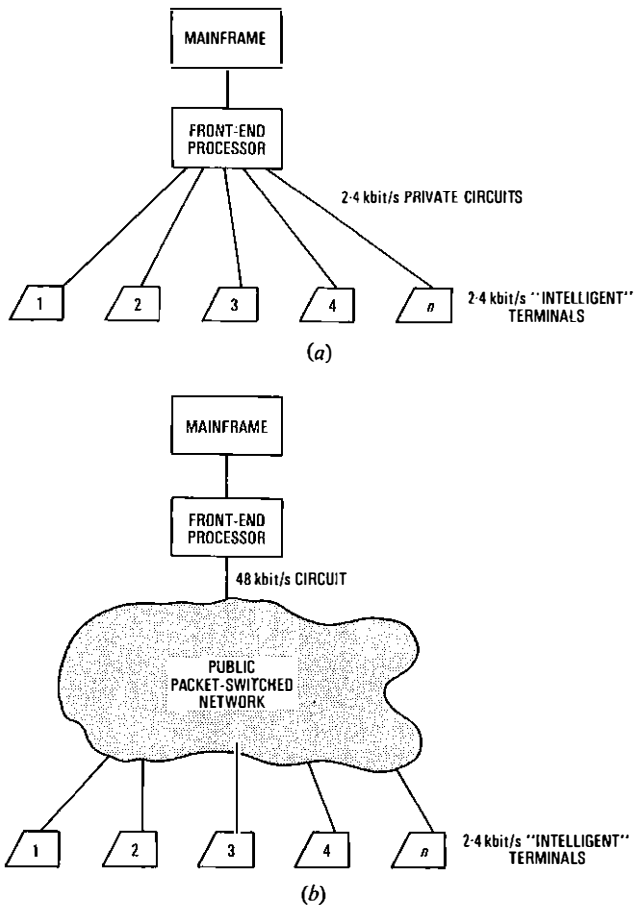

(a) Conventional star network  
(b) Using a public packet-switched network

FIG. 3.—On-line computer system

are closely associated with the operating software which has overall control of the mainframe. Provision of a packet interface, which involves modification of the communication software within the mainframe, is often fraught with difficulties because of the complex interdependency of this software with the operating software and the applications software.

### Front-End Processor

In its simplest form, the FEP is a hardware device (more accurately described as a communication controller than a processor) which enables a mainframe to control many communication lines and terminals. It can carry out the following basic line-scanning functions:

- (a) line sampling,
- (b) assembling bits into a character buffer for each line,
- (c) code conversion, and
- (d) transfer of characters to the scanner selector, which provides a channel to the mainframe.

A more sophisticated device can also carry out

- (a) message assembly,
- (b) polling† and selection, and
- (c) additional control procedures.

It can be seen that such devices operate at a very low level in the hierarchy of communication handling. They are not able to perform functions at the level of complexity of the

† Polling is the addressing of terminals on a rotary basis to determine whether they have anything to send

transmission protocol (level 2) and above, and are therefore incapable of acting as packet terminals.

A much more sophisticated and flexible device is a programmable FEP. In addition to the functions listed above, this can deal with

- (a) transmission control,
- (b) dynamic buffering,\* and
- (c) error recovery.

The programmable FEP provides a suitable resource within which the packet interface can be constructed. There are 2 possible approaches to providing the packet interface using the FEP.

Firstly, level 2 and 3 (transmission and call) protocols could be handled in the FEP, and packets transferred across to the input/output channel of the mainframe where they would be handled by the level 4 (bridging) protocol, written as a new input/output control routine. This would pose considerable problems in the mainframe because of the complex relationship with the operating software, and is not generally a practical proposition in an experimental environment such as the EPSS.

The second approach is to handle within the FEP all protocol levels up to and including level 4. In this way, the data stream received by the input/output control routine in the mainframe can be arranged to be in a standard format. This has the advantage that it avoids any changes within the mainframe, although it does result in a lengthening of the chain of command and the possible restriction of control facilities.

Despite the apparent feasibility of the second approach, it has not been adopted by many EPSS participants. The majority of participants with suitable FEPs are already using them fairly extensively within a normal operational environment. Often, the machine simply does not have sufficient spare storage space to accommodate the necessary software. There is also some uncertainty about the demands this software would make on the FEP, possibly affecting its ability to handle the normal operational load. Furthermore, participants using software supported by the manufacturer are unwilling to make modifications that would effectively eliminate that support.

### Interfacing Methods

#### Minicomputer Emulator

The most common method adopted is to use a minicomputer in which the packet interface has been constructed (up to and including the bridging protocol), and which appears to the FEP to be a remote terminal. For example, in an IBM environment, the minicomputer could emulate a HASP‡ work station (which is an RJE device), and operate via a conventional FEP to HASP software in the mainframe. ICL have developed a unit, based on their 7503 minicomputer, that emulates a visual-display-unit-cluster controller, and can interface with various operating systems on certain machines. This effectively shields the standard hardware and software from demands made by the packet protocols. It is a cost-effective approach to interfacing with the EPSS, but it does suffer from control limitations resulting from the long chain of command between the applications software and the packet interface.

#### Transmission Protocol Unit

A number of customers wished to use the standard transmission protocol, but lacked the resources to implement it in software. To meet this requirement, the BPO encouraged the develop-

\* Dynamic buffering is a method of using storage more efficiently by allocating buffers according to varying needs

‡ HASP is a commonly-used protocol that allows an RJE terminal to be serviced by an IBM computer

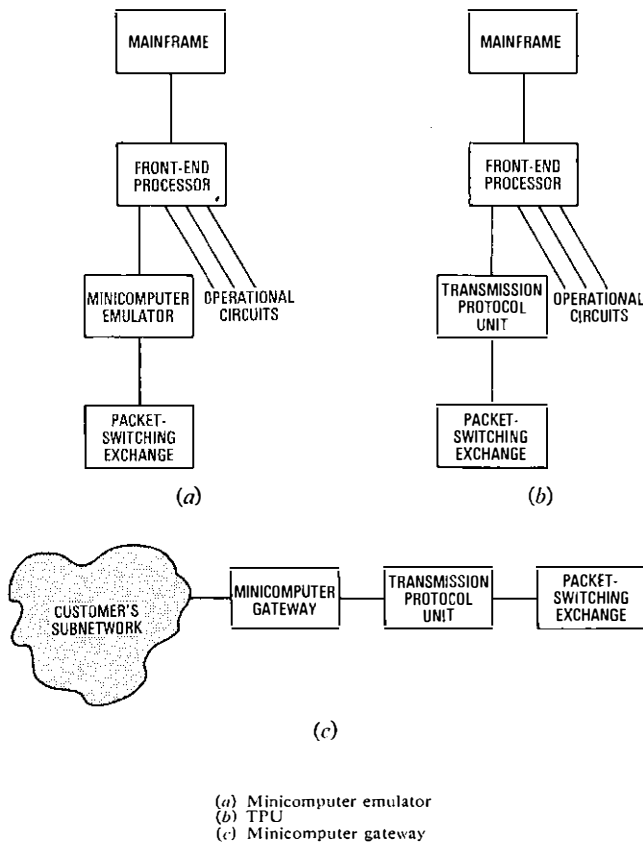

FIG. 4—Methods of interfacing a computer centre with the EPSS

ment of a hardware device, the transmission protocol unit (TPU), to handle the standard transmission protocol, and units are being produced by Computer Engineering Ltd. in conjunction with the National Physical Laboratory. The TPU relieves the FEP of a considerable amount of work, leaving it to deal with level 3 and 4 protocols.

Fig. 4 illustrates 3 typical solutions to the interfacing problem; Fig. 4(a) shows the use of a minicomputer emulator, and Fig. 4(b) shows the use of a TPU.

#### Minicomputer Gateway

The solution shown in Fig. 4(c) is more complex than those discussed so far. In this case, a minicomputer acts as a gateway to a customer's local subnetwork, providing a conversion between the EPSS protocols and those of the local network. The system requires the bridging protocol to take account of the addressing features of the subnetwork.

### THE TERMINAL INTERFACE

Construction of a packet interface for the EPSS at a terminal is practicable only if the terminal is programmable. This effectively means that the terminal must be based on the use of a minicomputer. This has tended to restrict the construction of packet terminals to RJE devices based on minicomputers. Other "intelligent" devices are often not programmable, the intelligence being contained in hardware which is not easily

modified. For RJE terminals, the problem is very self-contained, and the consideration of where activities should take place does not arise. Also, simplifications can be made within the bridging protocol; for example, the error-recovery procedures can be much more straightforward. Such simplifications are often necessary to minimize the use of the limited storage available.

### CONCLUSION

In specifying the EPSS, the BPO provided the basic network protocols. The customers have matched this by producing further protocols to interact with the network. Without this effort by the participants, their ability to use effectively the EPSS would have been severely restricted, and the value of customer participation would have been considerably reduced.

The experimental nature of the EPSS has led customers to adopt solutions aimed at making minimal changes to existing systems and, hence, keeping costs at a reasonable level. The result of this approach is some loss of flexibility of control, although this is not a serious drawback. There is no doubt that considerable expense has been incurred, with each customer supplying development effort to solve his particular system problems. Successful marketing of any future national packet-switched service will require the technical solutions to be optimized at a minimum cost to the customers and, to a large extent, this is dependent on the manufacturers of computer equipment.

The 2 most important factors that would encourage manufacturers are

(a) commitment of the BPO to a national packet-switched service in the UK, and

(b) the emergence of an international standard for packet switching.

The first will be influenced by the outcome of the EPSS. The second has progressed considerably within the last year, with the production of a draft CCITT recommendation.<sup>5</sup> If this is ratified in the present CCITT plenary session, the development of public packet-switched networks to this standard is likely to be rapid, and the future of packet switching will be assured.

### ACKNOWLEDGEMENT

The authors wish to acknowledge assistance obtained by reference to documents prepared by Mr. P. Down, of the National Computing Centre, Mr. P. Diamond, late of the BPO, and members of the EPSS Study Groups.

### References

- NEIL, W., SPOONER, M. J., and WILSON, E. J. Experimental Packet-Switched Service: Procedures and Protocols, Parts 1, 2 and 3. *POEEJ*, Vol. 67, p. 232, Jan. 1975, and Vol. 68, pp. 22 and 110, Apr. 1975 and July 1975.
- GARDNER, A. J., and SANDUM, K. N. Experimental Packet-Switched Service: Routing of Packets. *POEEJ*, Vol. 68, p. 235, Jan. 1976.
- CCITT Green Book, Recommendation V41.
- HADLEY, D. F., and MEDCRAFT, D. W. F. Experimental Packet-Switched Data-Transmission Service: Network Design and Implementation. *POEEJ*, Vol. 67, p. 88, July 1974.
- CCITT Recommendation X25.

# Regional Notes

## NORTH WEST TELECOMMUNICATIONS BOARD

### Ice Damage to Windy Hill Radio Station

Windy Hill radio station is situated beside the highest point of the M62 motorway at Denshaw, near Oldham, at an altitude of 400 m. On Friday 6 February, a combination of low cloud and below-freezing-point temperatures caused a rapid build up of ice on the tower. This was first noticed during a chance visit by the foreman of the rigging gang, Mr. C. Townshend. He informed his control who, in turn, informed the external radio maintenance group of the Network Planning Department, Telecommunications Headquarters (THQ).

On the following day, there was a thaw. Ice started to fall, damaging aerials and the roof of the radio station. Many telephony and television systems were affected but, fortunately, it was possible to patch out all the working systems. On Sunday 8 February, conditions had improved sufficiently for an inspection climb to be made, and it was found that all the aerial dishes except 2 were damaged in some way. Most were simply dented by falling ice, but one 6 GHz dish was damaged beyond repair, and the launching waveguide of a 4 GHz dish had been bent through 90°. The photograph shows the damage caused to the radio station's roof by falling ice.



The tower viewed through the damaged roof of the radio station

(Photograph by courtesy of Paul Francis Photography, Manchester)

The repair work was hampered by further bad weather, which included icing, snow, strong winds, mist and rain. During the following fortnight, climbing was possible for a total of only 43 h. The first 2 d were spent beating out the dented dishes with rubber hammers. A new 6 GHz dish was obtained from the Midlands Telecommunications Region (MTR) and was raised and landed on the tower with some difficulty because of strong cross-winds. The 4 GHz aerial with the damaged launching unit was at the topmost part of the tower, and to have replaced it would have involved special rigging. It was therefore decided to try repairing the launching unit *in situ*, which fortunately proved possible. This avoided having to replace the whole aerial.

Everything was restored to normal working order in 11 d, and the regional management would like to take this opportunity of expressing their thanks to all those involved from Manchester North Telephone Area, the MTR and THQ.

J. ACKERLEY (061-863 7511)

## WALES AND THE MARCHES

### Injection-Moulded Joint Closures

For some years prior to mid-1971, epoxy-resin joint closures on polyethylene-sheathed cables had been a source of dissatisfaction to both construction and maintenance personnel in Wales and the Marches Telecommunications Board (WMTB). Works Division jointers continually experienced difficulty obtaining a secure first-time closure, with subsequent problems when pressurizing cables prior to handing them over to Maintenance Divisions. In addition, Maintenance Divisions had difficulty maintaining the required pressurization standards. Both groups had particular difficulty with aerial cables.

This situation was the subject of much discussion and study during the latter half of 1971, and the conclusion was finally reached that the poor reliability of the closure was not due to bad workmanship, but that the method was inherently unsound. It was decided, therefore, to seek an alternative method of closing polyethylene-sheathed cables.

Before 1971, both Telephone Cables Ltd. (TCL) and British Insulated Callender's Cables Ltd. (BICC) had successfully closed cables in the WMTB using injection-moulding techniques, and the closures had remained free from faults. An examination of the fault record for a BICC contract-laid cable that had been injection-moulded in 1966, the oldest in the WMTB, showed that there had been 2 faults reported, neither of which was caused by failure of the injection moulding. Both manufacturers' methods consist of heating polyethylene until it is molten, and injecting it under pressure into a mould to complete the wipe between the cable sheath and jointing sleeve.

Both manufacturers' methods were studied, and it was decided to purchase a limited amount of TCL's equipment for a restricted trial on new work in the Cardiff and Chester Telephone Areas.

During 1972, instructors at the Telecommunications Training Centre (TTC) at Cardiff were trained by TCL and, in turn, trained Area jointers in the method. Contracts for the supply of equipment and stores were negotiated, and the first injection-moulded closures were made in the field in March 1973. Initially, the closures were confined to junction cables, but the field trial was quickly extended to include the local main network. During 1974, 8 junction cables were provided by direct labour using the TCL injection-moulding method.

The method met with the immediate approval of field staff. Jointers preferred using the injection-moulding procedure to epoxy-resin putty. It was evident that cables could be pressurized to the required standard, and subsequently handed over to Maintenance Divisions, more easily than for cables jointed using epoxy-resin putty. As a result of this early success, the Shrewsbury and Swansea Telephone Areas were included in the trial during July 1973.

After a demonstration to Experimental Changes of Practice Committee 1 (ECOPC1) in December 1974, Telecommunications Headquarters gave permission for injection moulding to be used as a standard method of closure (within the WMTB only) and agreed to sponsor the continuation of the field trial. The WMTB then arranged for direct-labour junction cables and local main-network cable development schemes to be provided using injection-moulding techniques, within the limits imposed by the training schedule and the availability of equipment.

Since the initial purchase of 6 sets of equipment, there have been regular purchases of additional sets, all of which have been used to their utmost capacity. At present, 25 kits are held by Works Divisions, 4 by Maintenance Divisions (1 per Area), and 4 sets are used by the TTC for training purposes.

Approximately 1000 joints have been closed since March 1973, and it has been estimated that there is an average direct-cost saving of about 70p per joint. It is also encouraging that no fault has been reported on any of these joints that was the result of a faulty injection moulding.

The closing of joints by injection moulding is not a difficult job, and it is not restricted to specialist jointers. All jointers reaching intermediate standard are trained in the technique, the course being of 1.5 week's duration at the TTC. So far,

160 jointers have been trained, with a further 6 jointers every fortnight taking the course.

In addition, the WMTB Maintenance Division recognized the advantages of injection moulding for the repair of faulty epoxy-resin-putty joints on existing cables. In particular, epoxy-resin-putty aerial-cable joints are unreliable, and a method of repairing these single-ended joints using injection moulding has been devised. The method uses split plugs, available from TCL. Subsequently, a method was also developed for the repair of faulty in-line joints on underground cables. Both the single-ended and in-line repair methods have been registered with ECOPC1 as official field trials.

It is expected that, with further development, the cheaper split-plug method will be usable on both new and repair work, thereby reducing the number of piece parts held in stock, with a consequent further cost reduction.

J. PRICE (0222 391224)  
T. SMITH (0222 391377)

## SOUTH EASTERN REGION

### Reading's Centenary Celebrations

The invention of the telephone in 1876 by Alexander Graham Bell was celebrated in the Reading Telephone Area by holding a "Telephone Fortnight". This event was coupled with the symbolic presentation by the General Manager, Mr. Robert Lack, of a self-contained Keyphone to the Chief Executive of Berkshire County Council, Mr. Robert Gash, to mark the connexion of the 400-thousandth telephone in the Area.

The anniversary activities commenced, with a press conference immediately before the presentation, during which reporters were invited to inspect examples of historic telephone equipment dating from the late-nineteenth and early-twentieth centuries. The display included early wall-type telephones, house telephones and a keysender of a type available to subscribers in the early-1930s which was still in its original packing and in good working order. Another item was a Second World War gas mask with a built-in operator's headset. Alongside these historic instruments were examples of modern telephone equipment to illustrate the progress made in the field of telecommunications compared with Bell's original invention.

Other features of the event were a display of modern telephone equipment in a Reading shop and a similar display laid out in the Regional marketing caravan at Bracknell shopping centre, near Reading.

Naturally, such an event required extensive publicity, and this was achieved by newspaper advertisements, posters in kiosks, and a number of advertisements on the local commercial radio station, Thames Valley Radio, which came on the air for the first time on Monday 8 March 1976.

The beginning of the Telephone Fortnight coincided with the start of a marketing and call-stimulation campaign which will continue long after the centenary event: The campaign is aimed at increasing the use of the telephone during cheap-rate periods, encouraging new subscribers, and selling extensions and ancillary equipment to existing subscribers.

On the marketing side of the campaign, there is positive evidence that our efforts are bearing fruit, but since there are no statistics that illustrate the effect of call-stimulation, except for ISD calls, it will be difficult to gauge the success or failure of call-stimulation measures. Some indication might be given by an increase in the revenue from metered units, although some of this will undoubtedly be due to additional users captured by the marketing activities.

The displays at the shop and in the caravan contained working examples of telephones and systems that can be used in the home, and included the new self-contained Keyphone. The latter aroused great enthusiasm, and nearly 200 have been ordered. The working models at the display included Keyphones, loudspeaking telephones, a telephone for the disabled, and various plan-sets and dialling devices. These were all connected to exchange lines through a switchboard so that visitors could try out all the available facilities. Connecting these lines at the shop presented no problems but, for the caravan, it was necessary to provide poles, overhead

feeds and aerial cables to give service. In addition, there was no easy or economic access to mains electricity, so that it was necessary to provide and maintain a portable generator to serve the caravan's requirements.

J. R. GERRARD (0734 51166)

## MIDLANDS REGION

### Rectory: The First TXE4

On Saturday 28 February 1976, the first TXE4 electronic exchange in the country was successfully brought into public service at Rectory in the Birmingham Telephone Area. The exchange was installed by Standard Telephones and Cables Ltd., and has an equipped capacity for 4300 subscribers. The opening was accompanied by the transfer of some 3000 subscribers from Sutton Coldfield Strowger exchange, the majority of them being taken off shared-service on transfer.

Ten cyclic-store racks, 3 main control units and two 6-plane switching units were provided to cater for the design-date traffic of about 0.025 erlangs/connexion. The equipment is housed in a standard single-storey K-type building, the ventilation ducting being concealed above a false ceiling, and the air being chilled by refrigeration equipment situated on the flat roof. The ultimate capacity of the site is 8000 connexions.

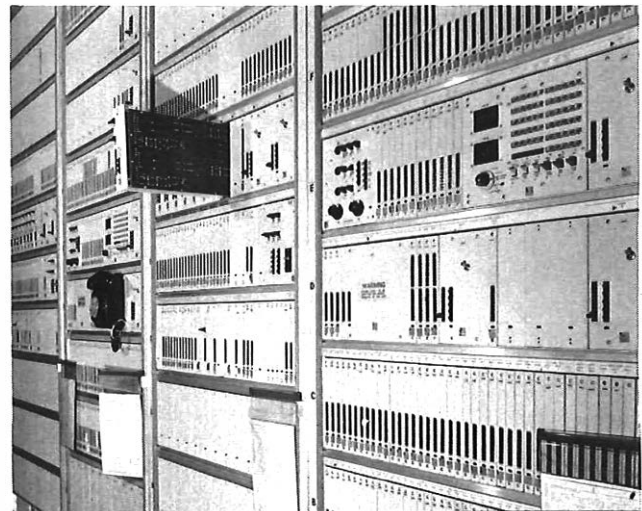

Rectory's common-control equipment, showing one register withdrawn

The opening followed extensive type-approval activities by the Telecommunications Development Department of Telecommunications Headquarters, which resulted in modifications that had to be carried out and checked within a predetermined time-scale designed to meet an opening date of February 1976. It is a tribute to the efforts and co-operation of the staff in Birmingham Telephone Area, and not least to the co-operation of the contractor's staff, both on and off the site, that this date was met and the exchange successfully brought into service.

No significant problems have arisen since the exchange was put into service, apart from some teething troubles with the traffic recorder.

The second stage of type-approval started after the exchange had been in service for 1 month, and was completed at about the same time as the start of Rectory's first extension, in May 1976. This extension will add one additional switching unit and capacity for 900 additional subscribers. It is programmed to be ready for service by mid-1977, and will enable Rectory subscribers who were allocated to Strowger expedient equipment (situated in a temporary wooden building at the rear of the site) to be transferred to the electronic exchange.

R. BIMSON (021-262 4583)

## NORTH WEST POSTAL BOARD

### A New Maintenance Aid for Chain Conveyors

Manchester letter-sorting office has 5 chain conveyors, 4 of which are of the type generally known as *Type-E8*. One of these has been particularly troublesome in the past, and it is known that similar problems have been experienced in other sorting offices since chain conveyors of this type are widely used.

The main problem is breakage of the chain element, which can cause track damage and which always involves many hours of out-of-service time for repairs. Breakages are caused by the elongation, owing to wear, of the spindle holes in the link plates. This elongation starts when the joint between the spindle and the link plate fails. The wear worsens because of the relative rotation between the spindle and the link plate, since the knurl that usually locks the case-hardened spindle into the link plate acts like a milling cutter. Failure of the conveyor occurs when the elongation is such that there is insufficient metal left on the end of the link plate to accommodate the load. Fig. 1 shows a link plate almost at the point of failure due to the milling-cutter action.

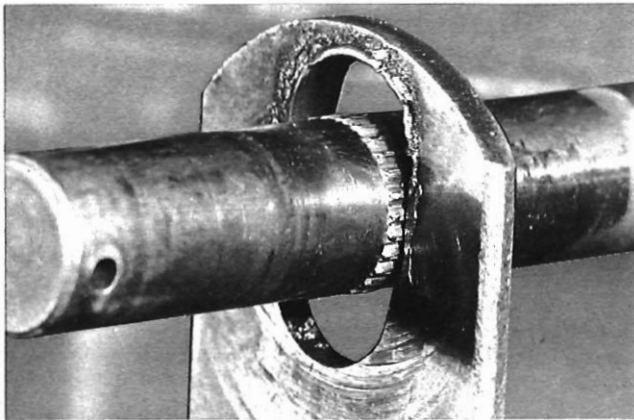

FIG. 1—Milling-cutter action of the knurled spindle on the link plate

Failure of the conveyor can be avoided if links in which the spindle holes have become elongated can be located and renewed before the elongation causes the chain element to break. A device that provides an automatic method of detecting faulty links was therefore designed and produced, since routine manual checking of long chain-conveyors, having upwards of 1000 links, is an extremely time-consuming procedure. The device has now been in use for more than a year, and has given satisfactory service in a number of sorting offices. As a result, another 6 devices have recently been produced at the request of Postal Headquarters.

The devices, known as *automatic chain-pitch monitors*, consist of 2 units: the control unit and the detector unit. Fig. 2 shows a detector unit mounted on a chain-conveyor track.

Automatic chain-pitch monitors are portable and are capable of operating on conveyors of various lengths and speeds. The automatic routine checking of a conveyor is carried out while the conveyor is in normal use. Detection of faulty links is achieved by means of photo-electric detectors sensing the chain-element wheels as they pass the detector housing. The housing is clamped to the chain-conveyor track, which has been previously drilled to suit. The adjustable detectors are coupled via logic circuitry to a counting digital printer in the control unit, so that faults are recorded on paper. Identification of faulty links is simple: unlike a satisfactory link, a faulty one causes a signal to come from the leading detectors before that from the trailing ones. The principle is illustrated in Fig. 3.

The detector unit initially detects a hole drilled in one of the

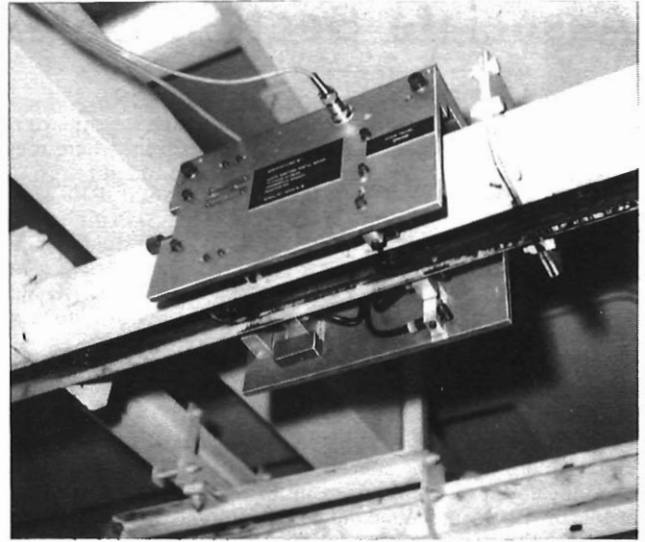
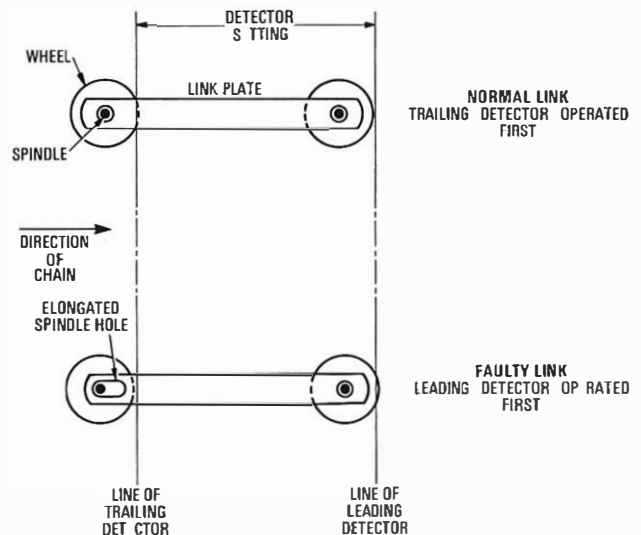

FIG. 2—Detector unit mounted on a chain-conveyor track



Note: Only one link is shown

FIG. 3—Principle of the detector

conveyor's bag-carrying brackets, thus triggering the circuits and starting the check for faulty links. As each link passes the detector housing, it is counted by the printer's counting mechanism, and apparent link lengths in excess of the chosen detector setting cause the printing mechanism to be activated. The check continues until the drilled bracket again passes the detector housing, signifying that a complete circuit of the conveyor has taken place. The unit then prints a known number which is one more than the number of links in the chain, thus enabling the user to be sure that the unit has not become out-of-step with the conveyor as the check progressed.

Print-outs for each completed check are compared, and the faulty links are individually located by reference to a chart giving the relation of the link numbers to the bag-carrier numbers, the chart having been previously drawn up by visual inspection of the conveyor. The worst links are then renewed.

The original problem of serious chain-element wear remains, and this can be solved only in the long term by the use of chain elements of a new type of construction. In the meantime, routine link renewal, making use of the automatic monitor, will enable troublesome conveyors to give the service they were intended to give.

A. J. MORTLOCK (061-245 6423)

# Associate Section Notes

## Aberdeen Centre

On 3 February, a party of members visited the headquarters of the Grampian Region Fire Brigade, Aberdeen, where they were shown some of the latest equipment used to fight fires.

On 16 March, Mr. W. Crook of the Scottish Telecommunications Board gave a lecture entitled *Statistics in the British Post Office*. On 24 March, Mr. L. Nash of the External Telecommunications Executive's North Sea Task Force gave a very interesting lecture on communications for North Sea oil and gas operations, illustrating the lecture with films and slides.

I. BOOTH

## Bedford Centre

This year's programme started in January, when winemaking was the subject of a talk given by Mr. S. Buckley, a member of the British Home Winemakers' Guild.

On 5 February, a party of 10 travelled to the New London Theatre for this year's Faraday Lecture, and we joined members of Luton Centre on 7 February for a visit to the train sheds at Plymouth.

Our forthcoming programme includes: visits to the British Post Office (BPO) railway, Mount Pleasant sorting office, the Houses of Parliament, and a skid pan; and talks on Old Bedford and the trunk transit network.

The 4 Centres in Bedford Telephone Area—Bedford, Blechley, Hemel Hempstead and Luton—are to hold a second Prestige Lecture on 22 September. The lecture, to be held at the County Hotel, Bedford, will be presented by Sir William Ryland, c.b. Chairman of the BPO Board.

D. B. B. WHITMORE

## Belfast Centre

The Belfast Centre continues its policy of creating interest in the Institution's activities among the younger members of staff by again sponsoring an essay competition for Trainee Technicians (Apprentices) (TT(A)s) in Northern Ireland. This competition has been extensively advertised and, with the co-operation of the Area Training Duty, all TT(A)s have also received a personal invitation. It is hoped that a good entry will result.

In April, we had a lecture on the technology and practices of the evolving telephone system and, in May, one giving an outline of the TXE4 system.

The Regional Technical Quiz was held on 14 April. Four teams took part: Ballymena, Belfast, Coleraine and Londonderry. The winning team was Ballymena.

D. McLAUGHLIN

## Edinburgh Centre

On Thursday 11 December 1975, 13 members attended a double visit to the Edinburgh Crystal Glassworks and Blackford Hill Observatory. At the glassworks, we were shown how glass is made from the raw materials, and engraved and cut to make the crystal we all know so well. The visit to Blackford Hill Observatory was a technical visit, and the use of optical telescopes and how international observations are collected were explained to us.

A talk entitled *River Pollution* was given by Mr. J. Gellaitry of the Lothian Purification Board on Monday 26 January. Attended by only 8 members, the evening was informal and extremely interesting.

The last meeting of our 1975-76 session took place on Wednesday 3 March, and was a talk entitled *Appraisal and Promotion Procedure* given by Mr. D. Leask, Deputy Controller of Personnel, Scottish Telecommunications Board. Twenty members attended this talk, and were told how the new appraisal procedures came about and why. A lengthy question time after the talk ensured that everyone left with a full knowledge of the new system.

J. L. M. ALEXANDER

## Exeter Centre

Our January meeting was a well attended and very well presented lecture, *Developments in Switching*, given by Mr. C. J. Maurer, Deputy Director, External Telecommunications Executive. This was followed, in February, by *Welding and Cutting Processes*, given by Mr. R. A. Upperton of the British Oxygen Company Ltd. This was a very interesting lecture, aided by slides illustrating many of the more recent developments. The last lecture of the session was *The Telex Exchange*, presented by one of our own members, Mr. R. W. Easton. This lecture was enthusiastically presented, held the attention of the audience, and did not probe too deeply into technical details.

Exeter Associate Section Centre competed in the National Technical Quiz Competition. We met Worthing in the quarter-final, winning the heat by 3 points, and the Midlands in the semi-final. This was a hard fight, and we won by only 1 point.



The winning team: (left to right) Mr. W. West, Mr. M. Rowe, Mr. I. Lightfoot (Captain), Mr. J. Petherick, Mr. I. Elston, and Mr. R. Allen

In the final, we met Bolton, and a very eventful year was concluded as we carried off the Bray Trophy. I would like to express our appreciation to all the officials who took part, and our congratulations to our winning team.

J. W. CLARK

## Kingston-upon-Hull Joint Centre

The 1975-76 session has been a quite successful session for the Centre, the membership increasing slightly during the year.

Some 30 members attended the North Eastern Regional Association Section Lecture at the York College for Further Education on Thursday 9 October 1975. An interesting paper on, and demonstration of, Viewdata was presented by Mr. S. Fedida of the British Post Office Research Department.

Our November meeting, at Telephone House, Hull, was a joint meeting with Scarborough Centre, and was a lecture on suspension bridges. This was an excellent paper, given by Mr. W. J. Harper, Project Director, Humber Bridge (British Bridge Builders Ltd.). The talk, illustrated by slides and models, dealt with the basic problems of building suspension bridges in general but, naturally, the Humber Bridge was discussed.

We visited the new cattle-food processing plant of Bakers & Lee Smith Ltd., at Beverley. The plant can be controlled manually or, more usually, by a computer on the site.

A well attended general meeting was held on 11 February 1976, when the following officers and committee were elected for the 1976-77 session.

*Joint Chairmen:* Mr. L. Anderson and Mr. P. Eglin.

*Honorary Treasurer:* Mr. G. Mudd.

*Honorary Secretary:* Mr. L. Johnson.

*Committee:* Messrs. W. Timson, W. Thomas, J. Glasgow, R. H. Miles, G. E. Reed, K. Gibson, D. Sharp, J. A. Moor, P. T. O. Jones and E. Shingles.

*Internal Publicity Officer:* Mr. B. Wheat.



Mr. P. Eglin, in the Chair, congratulated the team members who took part in the IPOEE Associate Section National Technical Quiz on their success in achieving the North Eastern Regional Director's Trophy. The team had gone on to play London over landlines, and managed another victory. The next round was against the current trophy holders, Oxford, on 17 December 1975 but, I regret to say, Oxford won, although we gave them some anxious moments towards the end of the contest. The team members were Messrs. P. Ashton, M. Barber, A. Preston, D. Sharp, E. Shingles, G. E. Reed and W. Thomas, with Mr. J. A. Moor in reserve. We would like to thank our adjudicators, Messrs. R. F. Baker, A. Owen and E. Rackley, all of Hull Telephones, for their services.

On 9 March, 30 members travelled to Bradford for the Institution of Electrical Engineers' 1975-76 Faraday Lecture, *The Entertaining Electron*. This was a superb example of such a lecture, presented jointly on the platform by Mr. F. Howard Steel and Dr. G. B. Townsend, assisted by a team of some 15 colleagues whose duties included controlling the lighting, preparing the demonstrations, balancing the quadraphonic sound system, operating the cameras, managing the stage, and producing the various displays. Mr. Alan James, M.B.E., of the Independent Broadcasting Authority, is the lecture's tour manager for this team. It was both an instructive and enjoyable evening.

The April meeting was a technical visit to the Telephone Department's Pentaconta (TXK3) crossbar exchange at Bransholme, arranged by permission of Mr. A. R. Matthews, Telephone Manager, Kingston-upon-Hull.

The officers and committee would like to thank members for their support during the past session.

L. JOHNSON

### Newport Centre

A 4-centre quiz, between Newport, Gloucester, Bristol and Bath, was held at Chepstow Leisure Centre on 1 May. Newport was the host centre.

After a close contest, Bristol was declared the winner, just beating Bath by 31 points to 30. Messrs. R. Turner, J. Cross, R. Carey and M. Bevan made up the winning team. The question-master was Mr. R. Thomas; Messrs. K. I. Fleet and W. C. B. Hoskins were scorers, and Mr. B. Coldrick was the time-keeper. Prizes were presented to the members of the winning team by Mrs. R. Thomas.

After the contest, the teams and guests were entertained by a buffet and dance.

K. I. FLEET

### York Centre

The 1975 annual general meeting elected the following officers for the 1975-76 session.

*Chairman:* Mr. T. J. Watts.

*Treasurer:* Mr. C. F. G. Thompson.

*Secretary:* Mr. G. Best.

*Assistant Secretary:* Mr. N. Coates.

*Committee:* Messrs. M. Blanchard, T. Perrin, J. J. Powell, J. E. Strangeway, R. Morgan and A. S. Mortimer.

A very successful programme of events ensued, including: lectures on winemaking (by a member of the National Wine-makers' Guild), Viewdata (by Mr. S. Fedida), the TXE4 exchange (by Mr. B. Robinson), Radiophones (by Mr. M. Frost) and the restoration of York Minster (by Miss H. Gibbs); and visits to the BICC Ltd. cable factory at Prescott, the British Rail marshalling yards at York, and Drax power station. Our 1976 annual general meeting in April was followed by a social evening.

G. BEST

---

## The Associate Section National Committee Report

### The National Committee

It is only 5 years since the National Committee was formed, and so it is only recently that the efforts of the committee began to bear fruit. We are recognized by the IPOEE Council as the national committee of the Associate Section, and we are pursuing a policy of improving facilities for Associate Section members. To this end, a questionnaire was recently circulated to all local secretaries, and I would be pleased to hear suggestions for future National Committee policy and activities.

### National Technical Quiz

The final was held on Friday 26 March at the Institution of Electrical Engineers, Savoy Place, London, with Exeter (South Western Telecommunications Region) beating Bolton (North West Telecommunications Board) by 40 points to 31½. It was an excellent result for both teams, who are to be congratulated on the high standard of their answers. Our thanks are offered to the question-master, Mr. J. F. P. Thomas, the scorer, Mr. K. E. Stotesbury, the time-keeper, Dr. P. R. Bray, and the adjudicators, Messrs. G. I. Andrew and K. J. Sansbury. The presentation of the Bray Trophy was by Professor J. H. H. Merriman, British Post Office Board Member for Technology.

A special presentation was also made to Mr. A. H. Watkins, Regional Liaison Officer for the South Eastern Telecommunications Region (SETR), who is retiring shortly. The presentation was made on behalf of the SETR Associate Section in recognition of his work and the encouragement he has given to others over the past years. Afterwards, a very

enjoyable buffet was attended by 60 people at Ye Olde Cheshire Cheese in Fleet Street.

### POEEJ

I am holding a substantial number of *POEEJs* going back as far as 1940, IPOEE printed papers back to the mid-1920s, and some copies of the *Post Office Telecommunications Journal* back to 1960. These are available to any member or Centre on request to the secretary of the National Committee (telephone: 01-462 1843).

### National News

A temporary news-sheet has recently been issued giving brief details of National Committee activities over the past year. It is hoped that, by the time this report appears, the first issue of the new *National News* will have been printed (issue 11). Any items of news or articles for inclusion in the *National News* should be sent to the editor, Mr. C. F. Newton, Post Office Regional Engineering Training Centre, Kineholm, West Busk Lane, Otley, Yorkshire.

### Cotswold Trophy

This year's winner of the Cotswold Trophy is Sheffield Centre, who were considered to be the centre whose activities had done most to further the aims of the Associate Section in the past year. The trophy was presented at the National Committee conference in May.

C. J. WEBB  
Secretary

# Institution of Post Office Electrical Engineers

## INSTITUTION FIELD MEDAL AWARDS 1974-75

In addition to the Institution's Senior and Junior Silver and Bronze Medals, the Field Medals are awarded annually for the best papers read at meetings of the Institution on field subjects, primarily of Regional interest. A Field Medal was awarded to Mr. D. G. Shore of Birmingham Centre for his paper *External Contracts—Can We Reduce Costs?*, read during the 1974-75 session.

## ESSAY COMPETITION 1975-76

Prizes and Institution Certificates have been awarded to the following competitors in respect of the essays named.

The Council of the Institution records its appreciation to Messrs. E. V. Partington, J. Pritchett and J. Axon, who kindly undertook to adjudicate the essays entered for the competition.

The prize-winning essays will be kept in the Institution's central library, and will be available to borrowers.

### Section 1

Essays submitted by members of the Institution in all British Post Office (BPO) grades below the senior salary structure and above the grades defined in Section 2 below.

#### Prize of £15

Mr. K. R. Rawlings, Assistant Executive Engineer, Eastern Telecommunications Regional Headquarters. *The Planning, Programming and Budgeting System in the Post Office.*

#### Prize of £10

Mr. V. A. E. Fountain, Executive Engineer, Telecommunications Development Department, Telecommunications Headquarters. *An Economic Outline of Computer-Controlled Telephone Exchanges.*

### Section 2

Essays submitted by BPO staff below the rank of Inspector.

#### Prize of £18

Mr. C. D. Rasmussen, Technical Officer, Oxford. *High Wycombe's Mini-Tunnel.*

#### Prize of £12

Mr. L. Johnson, Technical Officer, Hull. *The Search for the Articulating Telephone.*

#### Prizes of £10

Mr. G. D. Rudram, Technical Officer, Arundel. *The Need for a Path-Analyser Tester in TXE2 Exchanges.*

Mr. D. E. F. Blandford, Technical Officer, Southsea. *Introduction of the Spare-Plant Return (SPRET) in the Portsmouth Area.*

### Certificates of Merit

Institution Certificates of Merit have been awarded to the following competitors.

Mr. J. R. K. Morrison, Technician 2A, London Telecommunications Region. *The Viewphone—Its Desirability in Terms of Human Privacy, its Technical Problems, its Technology and Economics.*

Mr. M. J. Hunt, Temporary Technical Officer, Swansea. *The Future of Precision Testing—An Introduction to the Echometer.*

Mr. R. M. Maclachlan, Technical Officer, Perth. *Special Investigation of Customers' Complaints—The Importance of Human Relationships.*

### RETIRED MEMBERS

The following members, who retired during 1975, have retained their membership of the Institution under Rule 11(a).

L. M. Baker, 13 Garlies Road, Forest Hill, London SE2.  
E. J. T. Hitchin, Witzies, Church Road, Hartley, Dartford, Kent.

J. R. Walters, 20 The Green, Bexley Heath, Kent.

J. S. Bristow, Sedgefield, Longford, Bristol.

D. J. M. Links, 6 Shady Bush Close, Bushey, Hertfordshire.

E. C. Offord, Pine Bluff, Horseshoe Bend, Grayshott, Hindhead, Surrey.

N. W. Weedon, Packs Hill, Summerhouse Road, Godalming, Surrey.

R. E. Blann, 17 Dinsdale Drive, Kingsbury, London NW9.

H. C. Naylor, 39 Mount Crescent, Brentwood, Essex.

R. Macpherson, The Croft, 45 Bishop's Road, Cleeve, Bristol.

R. J. Griffiths, 42 The Fairway, Northwood, Middlesex.

R. W. Gibson, 15 Essex Road, Chingford, Essex.

A. W. Preston, 14 Strongbow Road, Eltham, Middlesex.

J. D. Hill, Darley House, St. Paul's Street, Leeds.

G. A. Soames, 7 Prospect Drive, Llandaft, Cardiff.

W. H. Dolan, Cranbourne, Fairwater, Cardiff.

G. E. Rossiter, Flat 4, 3 The Avenue, Poole, Dorset.

A. H. Watkins, 9 Ainsworth Close, Ovingdean, Brighton, Sussex.

D. W. Wait, 12 The Esplanade, Telcombe Cliffs, Newhaven, Sussex.

W. A. Ellis, 34 Knightwood Crescent, New Malden, Surrey.

J. A. Kynaston, Dorrington Place, Dorrington, Shropshire.

R. P. Glover, 109 Heol Gabriel, Whitchurch, Cardiff.

L. New, 20 Ridgeley Drive, Ponteland, Newcastle-on-Tyne.

J. T. Turk, 8 Elm Way, Worcester Park, Surrey.

J. O. Thompson, 29 Hazeldene Meads, Brighton, Sussex.

W. H. Bird, 82 Leylands Road, Burgess Hill, Sussex.

J. H. Unwin, Jays, Stamages Lane, Painswick, Gloucestershire.

R. A. Attril, 27 Old Park Road South, Enfield, Middlesex.

A. B. WHERRY  
Secretary

### IPOEE CENTRAL LIBRARY

The following books have been added to the IPOEE Library since the publication of the 1974 Library Catalogue. Any member who does not have a copy of the catalogue can obtain one from the Librarian, IPOEE, 2-12 Gresham Street, London EC2V 7AG. Library requisition forms are also available from the Librarian, from honorary local secretaries, and from Associate Section local-centre secretaries and representatives.

5202 *Radio-Control Handbook*. H. G. McEntee (America, 1974).

Primarily concerned with radio control of model aircraft in flight, but much of the basic equipment described can be adapted for many other control applications.

5203 *Advanced Communication Systems*. Editor: B. J. Halliwell (1974).

Mainly concerned with long-distance transmission systems. Describes pulse-code modulation, digital networks, and microwave-radio and communication-satellite systems.

5204 *Piezoelectric Ceramics*. Mullard Ltd. (1974).

Describes the properties of a comprehensive range of piezoelectric ceramics, and how they can be used to make transducers for various applications.

5205 *Basic Electronics: Devices, Circuits and Systems*. M. Cirovic (America, 1974).

Written with the student in mind, this text gives a full coverage of the essentials of solid-state electronics. There are review questions at the end of each chapter, and problems at the end of most.

5206 *Noise and Fluctuations in Electronic Devices and Circuits*. F. N. H. Robinson (1974).

This book relates the practical effects of noise to basic physical laws in a way that is interesting to the physicist and useful to the engineer.

5207 *Microwave Mobile Communications*. Editor: W. C. Jakes (America, 1974).

Reviewed in the *POEEJ*, Vol. 69, p. 18, Apr. 1976.

5208 *Telecommunications*. J. Brown and E. V. D. Glazier (second edition, 1974).

Covers the fundamental principles of telecommunications, and is designed to meet the needs of students of electrical and electronic engineering.

5209 *Questions and Answers: Electrical Wiring*. H. A. Miller (1974).

Designed to give well-illustrated information concerning wiring simply and in a logical sequence.

5210 *Questions and Answers: Hi-Fi*. C. Brown (1974).

Intended to guide amateur enthusiasts and act as a reminder of modern practices to advanced students.

5211 *Electronic Integrated Circuits: Their Technology and Design*. J. Allison (1975).

Provides undergraduates and practising engineers with a comprehensive introduction to design and fabrication processes for integrated circuits.

5212 *Handbook of Plastics in Electronics*. D. Grzegorzczuk and D. Feineman (America, 1974).

An up-to-date book on plastics and their application in electronics for electronic engineers, technicians and students.

5213 *Electronic and Switching Circuits*. S. M. Bozic, R. M. H. Cheng and J. D. Parsons (1975).

Based upon lectures given by the authors to undergraduate students, this book expresses some of the fundamental aspects of electronic circuits in a way that non-specialists can understand.

5214 *110 Operational Amplifier Projects for the Home Constructor*. R. M. Marston (1975).

One hundred and ten useful projects are described, ranging from simple amplifiers to sophisticated instrumentation circuits. This book will be of equal interest to the amateur, student, and practising engineer.

5215 *The Telephone and the Exchange: An Introduction to Telecommunications for Students*. P. J. Povey, Curator of the British Post Office Telecommunications Museum, Taunton, Somerset.

For young people who intend to make their career in telecommunications, this book should provide a foundation on which they can later build their specialist knowledge, while for those whose future lies outside telecommunications, it is a valuable educational source.

E. DOHERTY  
Librarian

**POEEJ: Subscription Order Form**

Those wishing to subscribe to *The Post Office Electrical Engineers' Journal* can do so by completing the relevant section of the order form below. British Post Office (BPO) staff should complete the upper section and send it to their local *POEEJ* agent or, in cases of doubt, to the address shown; non-BPO staff should complete the lower section. A photocopy of this form is acceptable.

**Subscription Order (BPO Staff)**

To: The Local Agent (*POEEJ*), or  
*The Post Office Electrical Engineers' Journal* (Sales),  
2-12 Gresham Street, London EC2V 7AG.

**The Post Office Electrical Engineers' Journal:  
Authority for Deduction from Pay**

Please arrange for me to receive *The Post Office Electrical Engineers' Journal*. I have completed the form opposite authorizing deductions from pay to cover the special annual subscription of £1.08.

I, .....  
(name in full, surname first in block capitals), authorize the deduction from my salary or wages, until further notice, of the sum of 9p per month/2p per week for payment to the Managing Editor, *The Post Office Electrical Engineers' Journal*, on my behalf.

Date..... Signature.....

Date..... Signature.....

Name and .....  
initials (in  
block capitals) Rank.....

Official address.....

Official address .....

Rank..... Pay No.....

Area/Dept.....

**Yearly Subscription Order (Non-BPO Staff)**

To: *The Post Office Electrical Engineers' Journal* (Sales),  
2-12 Gresham Street,  
London EC2V 7AG.

Name .....

Please supply 4 quarterly issues of *The Post Office Electrical Engineers' Journal*. I enclose a cheque/postal order for the sum of £2.40 (Canada and the USA: \$6.00) to cover the yearly subscription.

Address .....

Please state with which issue you wish your subscription to commence (April, July, October or January).....

(Cheques and postal orders, payable to "*The POEE Journal*", should be crossed "& Co.", and enclosed with the order. Cash should not be sent through the post.)

# Notes and Comments

## Correspondence

Telecommunications Management  
Services Department,  
Telecommunications Headquarters.

Dear Sir,

I was dismayed to read, in an otherwise excellent article (*Translation Equipment for British Post Office Local-Line Wideband Systems, POEEJ*, Vol. 69, p. 51, Apr. 1976), reference to transmission levels of so many decibels relative to 1 mV (abbreviated to dBmV), particularly as a few years ago, when I was privileged to work in the field to which the article refers, I tried hard (indeed, I thought I had succeeded) to persuade my then colleagues of the ambiguity, if not nonsense, of such a term.

When a gain, loss or level is expressed in decibels, this implies a measure of the ratio of 2 powers; thus,

$$\text{gain or loss} = 10 \log_{10} (P_1/P_2) \text{ decibels,}$$

where  $P_1$  and  $P_2$  are measures of power, or

$$\text{level} = 10 \log_{10} (P/P_{\text{ref}}) \text{ decibels,}$$

where  $P$  is the power level to be defined, and  $P_{\text{ref}}$  is a reference power (generally, 1 mW).

Of course, power can be defined in terms of voltage and resistance; for example,  $P_1 = V_1^2/R_1$ , etc. Thus, gain (or loss) can be expressed as

$$10 \log_{10} \{(V_1^2/R_1) \times (R_2/V_2^2)\} \text{ decibels.}$$

Only if  $R_1 = R_2$  does this become

$$\text{gain or loss} = 20 \log_{10} (V_1/V_2) \text{ decibels.} \dots (1)$$

Thus, a level of so many decibels relative to 1 mV is meaningless unless the relevant resistances are defined, and to use expression (1) as though it were generally true, without carefully noting the condition which makes it true in the particular, can only lead to ambiguity and confusion.

Quite apart from the inevitable confusion arising out of the use of such woolly terms, I am at a loss (if you will pardon the pun) to understand why the authors did not use standard transmission terms (for example, decibels relative to 1 mW) which have stood the test of time, and which most transmission engineers find so clear, unambiguous and useful.

Yours faithfully,  
T. Lomas

*The authors of the article referred to were invited to comment on the points raised by Mr. Lomas, and their reply is reproduced below.*

Telecommunications Development Department,  
Telecommunications Headquarters.

Dear Sir,

The authors agree with Mr. Lomas that decibels express ratios of powers, and can be used to express voltage ratios only if the impedances, across which the voltages are measured, are equal.

The term "decibels relative to 1 mV" is used in the cable-television industry, in all parts of the world, to represent levels relative to a reference of 1 mV r.m.s. across an impedance of 75  $\Omega$ . The authors understand that the power corresponding to 1 mV r.m.s. across 75  $\Omega$  was chosen as a reference because it is approximately the power required by a typical television receiver for satisfactory operation. The level of a signal at any point in a 75  $\Omega$  cable-television system, expressed in decibels relative to 1 mV, therefore indicates how much attenuation can be permitted between that point and the receiver.

The British Post Office uses decibels relative to 1 mV for cable-television work to avoid possible misunderstandings and the constant need for conversion when dealing with suppliers, the British Standards Institution, the International Electrotechnical Commission, and other operators. The table compares levels expressed in decibels relative to 1 mV across 75  $\Omega$  and decibels relative to 1 mW.

Point of Measurement	Decibels relative to 1 mV (dBmV)	Decibels relative to 1 mW (dBm)
Translator Output	+40	-8.8
Translator Input	+10	-38.8
System Outlet (minimum level)	0	-48.8

Yours faithfully,

G. H. Barlow  
J. B. Hawkes  
C. H. Robbins

*Note:* The editors take the view that the use of the decibel relative to 1 mV (dBmV), although not ideal, is acceptable since communication engineers are generally aware of the conditions that make its use valid. The International Electrotechnical Commission has adopted for publication a Study Group Report dealing with the use of the term decibel. This Report considers the use of the decibel for absolute voltage levels, and accepts its use where the reference voltage and relevant impedances are defined, as in the article under discussion. It recognizes the usefulness of expressing voltage levels rather than power levels in some applications. The Report's only reservation concerns the case where the impedances are not specified, when it concludes that it is imperative to make it clear that the term decibel refers to an absolute voltage level and not a power level. In such a case, it would be preferable to use an alternative term, but, so far, no proposal to that effect has been adopted. (A succinct definition of the dBmV is given in the footnote on p. 117 of this issue.)

## Publication of Correspondence

The Board of Editors would like to publish correspondence on engineering, technical or other aspects of articles published in the *Journal*, or on related topics.

Letters of sufficient interest will be published under "Notes and Comments". Correspondents should note that, as it is necessary to send copy to the printer well before publication date, it will be possible to consider letters for publication in the October issue only if they are received before 13 August 1976.

Letters intended for publication should be sent to the Managing Editor, *The POEE Journal*, NP 9.3.4, Room S 08, River Plate House, Finsbury Circus, London EC2M 7LY.

## Correction

The presentation of the answer to part (a) of Question 7.2 in the 1974 edition of the Model Answer Book for Telecommunication Principles B is misleading. The voltage across the terminals of the inductor has been derived by multiplying the current flowing by the reactance of the inductor. Strictly, the current should be multiplied by the impedance of the inductor. However, as the resistance is very small compared with the inductive reactance, its effect on the value of the impedance is negligible, and it has therefore been ignored.

## Regional Notes and Short Articles

The Board of Editors would like to encourage contributions suitable for publication under "Regional Notes", and short articles dealing with current topics related to engineering, or of general interest to engineers in the British Post Office (BPO).

The "Regional Notes" section is intended for engineers in Telecommunications and Postal Regions and Telephone Areas briefly to report items of technical or management content, and to describe the solutions adopted to solve specific problems that may be of interest to other Regions, Areas and departments. Also, items of general interest to engineers in the BPO are welcomed.

Authors must obtain approval for publication of their contributions at General Manager or Regional Controller level.

As a guide, there are about 750 words to a page, allowing for diagrams; Regional Notes are generally up to about 500 words in length. Articles and Regional Notes should preferably be illustrated, where possible, by photographs or sketches. Contributions should be sent to the Managing Editor, *The POEE Journal*, NP 9.3.4, Room S 08, River Plate House, Finsbury Circus, London EC2M 7LY.

### Guidance for Authors

Some guiding notes are available to authors to help them prepare manuscripts of *Journal* articles in a way that will assist in securing uniformity of presentation, simplify the work of the *Journal's* printer and illustrators, and help ensure that author's wishes are easily interpreted. Any author preparing an article for the *Journal*, who is not already in possession of the notes, is asked to write to the Managing Editor to obtain a copy.

It is emphasized that all contributions to the *Journal*, including those for Regional Notes and Associate Section Notes, must be typed, with double spacing between lines, on one side only of each sheet of paper. Articles, and contributions for Regional Notes, must be approved for publication at General Manager/Head of Division (Regional Controller) level.

Each circuit diagram or sketch should be drawn on a separate sheet of paper; neat sketches are all that are required. Photographs should be clear and sharply focused. Prints should preferably be glossy and should be unmounted, any notes or captions being written on a separate sheet of paper. Good colour prints and slides can be accepted for black-and-white reproduction. Negatives are not required.

### Special Issues and Back Numbers

Copies of the April 1974 issue covering sector switching centres, and the October 1973 special issue on the 60 MHz transmission system, are still available.

Back numbers can be purchased, price 60p each (including postage and packaging), for all issues from January 1972 to date.

Copies of the July and October 1970, and the January 1971, issues are also still available. These issues contain all 3 parts of *Progress in Postal Engineering* by N. C. C. de Jong. The July 1970 issue also contains articles on the lives of plant and depreciation, medium range ship-to-shore radio services, and simple logic circuits using metal-oxide-semiconductor integrated circuits.

The October 1970 issue contains articles on monitoring the speed of stand-by engine-generator sets, standard video equipment, and the call-failure detection equipment. The January 1971 issue contains articles on the 20-line key-and-lamp desk unit, frequency-division-multiplex transistorized line systems, testing broadband radio links, and the standardization of programmable logic.

Orders, by post only, should be addressed to *The Post Office Electrical Engineers' Journal* (Sales), 2-12 Gresham Street, London EC2V 7AG. Cheques and postal orders, payable to "*The POEE Journal*", should be crossed "& Co." and enclosed with the order. Cash should not be sent through the post.

### Model Answer Books

Students of the City and Guilds of London Institute Telecommunication Technicians' Course are reminded that books of model answers are available in certain subjects. Details of the books available are given at the end of the Supplement. Copies of the syllabi and question papers are not sold by *The Post Office Electrical Engineers' Journal*, but can be purchased from the Department of Technology, City and Guilds of London Institute, 76 Portland Place, London WIN 4AA.

---

## Post Office Press Notices

### Data Handbook

Computer communication continues to be the fastest growing sector of British Post Office (BPO) telecommunications. Computing and telecommunications are now inseparable. For most people, the only way a terminal in a user's office can be connected to its computer is by a telephone or Telex circuit. While it is being used for sending computer data, the circuit becomes an integral part of the computing process being carried out over it.

In consequence, thousands of people engaged in computing become involved in the complexities of telecommunications, and BPO staff, who provide and maintain the circuits used for carrying computer data, find themselves dealing, on a technical level, with people whose technical background can be very different from their own.

The BPO has done a great deal to bridge the communications gap between the 2 technologies. In addition to training its own staff who serve computer users, it holds a range of training courses in data communication for computing staff. Seminars have been held at regular intervals over the last 6 years to provide up-to-date information for users of BPO data-communication services and products.

The BPO has now augmented this effort by producing a handbook of data communication, based on the training-course syllabus. The handbook is intended as a reference work on data communication for computer staff who need

to acquire a knowledge of telecommunications. It covers those subjects that have been found to be most needed by the average student.

Priced at £8.50, the book is published for the BPO by the National Computing Centre. It can be obtained from technical bookshops or direct from the BPO at:

Post Office Telecommunications,  
Data Communications Division,  
TMk 4.3.1,  
Freepost,  
London EC2B 2TX.

The subjects covered are

- (a) the origins and nature of data communication,
- (b) telephone and Telex systems,
- (c) communicating information,
- (d) transmission and modulation systems,
- (e) data terminals,
- (f) line control,
- (g) the communications interface,
- (h) data errors,
- (i) concentrators and multiplexers,
- (j) distributed intelligence,
- (k) message and packet switching,
- (l) data-transmission services in the UK, and
- (m) international data communication.

## European Investment Bank Loan for Scottish Telecommunications Board

A £17.3M loan, to help improve and extend the telephone service in Scotland, was agreed in February by the British Post Office (BPO) and the European Investment Bank (EIB), the EEC's long-term-finance institution.

The loan will be used to help pay for 226 new telephone exchanges, 589 extensions to existing exchanges, and other improvements to services in Scotland.

In its current capital-investment programme, the Scottish Telecommunications Board is spending a total of £160M. The Common Market loan forms only part of this.

The EIB loan represents a valuable saving for the BPO, as the rate of interest—fixed at 9.5%—is significantly lower than that obtainable from UK sources at present. It is the second loan made by the EIB to the BPO, and will be repaid over a period of 10 years. The first, totalling £17.5M, was made in September last year under similar terms, and is being used to extend and improve telephone services in Wales.

## The Nation's Achievements

"In an era when it is fashionable to knock the UK, it's about time the British people gave credit to the nation's achievements," said Sir William Ryland, Chairman of the British Post Office (BPO).

In a message marking the centenary of the birth of the telephone, Sir William said, "If Alexander Graham Bell were alive today, he would be proud of what we have done in this country. The Post Office telecommunications system installs 1200 'phones an hour, handles 43-million 'phone calls a day, is the third largest in the world, and invests at the rate of £1700 a minute, day and night."

Sir William added, "In this centenary year, we shall achieve another important milestone: we are about to install the country's 21-millionth telephone."

Britain's telephone network grew by nearly 600 000 exchange lines during 1975. At the end of the year, 13 093 000 lines were in service, 594 000 more than at the end of 1974—an increase of 4.8% during the year. A breakdown of the figures shows that the number of domestic connexions rose by 566 000 to reach 9 898 000. Business connexions rose by 28 000 to a total of 3 195 000.

The Telex network sustained a growth of 9% in 1975, despite the country's depressed economy. During the year, the number of Telex lines increased by 4758, reaching a total of 57 850.

Data-communication services continued to maintain a healthy growth in 1975. The number of working terminals exceeded 40 000 for the first time. At the end of January 1976, there were 40 654 Datel terminals in service, an increase of more than 10% on the corresponding figure a year earlier. The total number of Datel terminals is made up of 36 298 Datel modems, providing data transmission over telephone lines, and 4356 Datel 100 connexions to Telex circuits.

"The future of telecommunications is strong," said Sir William. "We are keeping pace with the fast changes in technology. We are modernizing our vast network of assets and, at the same time, meeting a rapid growth in demand for our services."

## Prospects for the Future

"By the end of the century, 1500-million telephones round the world will be carrying more than a million-million telephone calls a year."

This forecast of a 4-fold increase in the size and use of the world's telephone network was made by Sir Edward Fennessy, Deputy Chairman of the British Post Office (BPO) and Managing Director of Telecommunications, on the one-hundredth anniversary of Alexander Graham Bell's first telephone message.

A more detailed picture of communications in the future was painted by Professor James Merriman, BPO Board Member for Technology and Senior Director of Development.

"Looking at the present world system—the largest integrated man-made machine, representing an investment of over £50 000M and growing at 7% a year—observable trends are easily stated," Professor Merriman said.

One of them was steady growth; telecommunications had become part of the basic fabric of society, and crucial to its maintenance.

Looking at trends based on developments in technology, he foresaw further continuing significant reductions of the cost, in real terms, of the main arteries of long-distance transmission. These would be achieved by combining developments in existing basic technologies with the rich possibilities offered by optical-fibre transmission and guided radio waves.

The present growth in demand for intercontinental systems—if it persisted—could present severe challenges to basic engineering and science. Because of the natural limitations of the radio-frequency spectrum and orbital allocations for geographically-stationary satellites, future growth would depend on international regulation, on developing hitherto unused radio frequencies, and on advances in satellite station-keeping and aerial-pointing accuracy. "It also depends," said Professor Merriman, "on the extent to which a global girdle, or 'busbar' highway, of intersatellite links can be created. For these reasons, if for no other, we must expect continuing development in complementary high-capacity under-sea cable systems."

Telephone-exchange systems would come to depend increasingly on micro-electronic technology. The greater availability of advanced devices could change the balance between hardware and software, particularly in view of the growing problems of designing and maintaining disciplined error-free control over very large software systems. The lower cost of these devices could lower the threshold at which digital designs became viable. As a result, the present tightly-drawn boundary of the exchange could become blurred, with some elements of future telephone exchanges being dispersed, and located in community areas or on customers' premises.

Other trends, more social and economic in character, were emerging to challenge technology, Professor Merriman said. One was the influence of "globality"—the growing extension of direct contact between people in different countries by an automatic telephone service. This development had been made possible by lengthy and detailed negotiations in the international bodies responsible for drawing up standards for world telecommunications. Decades of patient work, building up a complex structure of international standards, had put into the hands of members of the public the ability to inter-communicate quickly and easily, just by following simple procedures devoid of ambiguity.

Changing need was another influence on technology. The emergence and growth of Telex, data transmission and facsimile were the forerunners of what seemed likely to be in use in the twenty-first century—office-to-office document transmission direct from dictation, and overnight automatic document handling and transmission.

The need for electronically-assisted access to facts, figures and pictures, resulting from the use of the television screen as a display device for news and information, seemed to be emerging strongly, Professor Merriman said, referring to current demonstrations of teletext services in Britain, France and Japan.

He pointed to a further need for multi-party communication. One form was the business conference, using ConferVision or its equivalent. Another form was to "add-on-others" to an original call between 2 people; for example, secretaries trying to arrange mutually-acceptable dates for a group of people.

The desire for "add-on" multi-party communication also arose out of the sense of increasing isolation many people felt at home or at work in modern society. "Is there", Professor Merriman asked, "a need, or a role, for the electronic equivalent of a walk down the village street, the gossip session, a squawk-box on an electronic highway, an all-party open line, by which a neighbourhood cohesion could be stimulated, and from which any 2 parties can withdraw to more local and private communication?"

## Awards for Fine Work

Nine research workers at the British Post Office's (BPO's) new research centre at Martlesham Heath have received awards for work of outstanding quality.

The awards, highly regarded by Research Department staff for the prestige attached to them, were the 1975 Scientific and Craftsmanship Premiums of the Gordon Radley Fund (Christopher Columbus Prize). Awarded annually, they were presented this year by Professor James Merriman, BPO Board Member for Technology and Senior Director of Development, who formerly worked on radio development at Dollis Hill, London, the previous centre of BPO research. He was introduced by Mr. Charles May, Director of Research, who is a trustee of the fund.

Scientific premiums are awarded to young scientists and engineers for research work described in papers published in scientific or technical journals or in a comparable way. This year, 3 scientific premiums were awarded. They went to: Dr. John Grierson, 27, from Stoke Park, Ipswich, for work on high-power micro-electronic devices (IMPATT diodes), which are being studied for use in future microwave-radio and waveguide systems; Dr. Ian Garrett, 31, from Watford, for studies of crystals and their production; and Mr. Michael Reeve, 25, living in Kempton Road, Ipswich, for work on optical fibres.

In addition, Mr. Michael Maddison, 26, was highly commended for a study of a computer-like processing system capable of being used to control future telephone exchanges.

The craftsmanship premiums are presented to technical staff for precision engineering work displaying particularly high skill in design and production. There were 4 awards for 1975, to: Mr. Harry Crisp and Mr. Roger Bates, both from Ipswich, for a large injection-moulding tool used for producing small precision insulators in plastics; Mr. Peter North of Woodbridge for a printing machine, used to print coded dots on envelopes in automatic letter-sorting equipment; Mr. John Williams of Hendon for making a special holder for a piece of gauze to enable its resistance to air-flow to be measured accurately; and Mr. Arthur Wright of Bramford and Mr. Robin Hooper-Greenhill of Claydon for designing and making electronic equipment used in association with a computer for timing and counting.

In addition, Mr. Graham Cosier of Stanmore was highly commended for a device to hold a telephone microphone so that its acoustic performance could be tested.

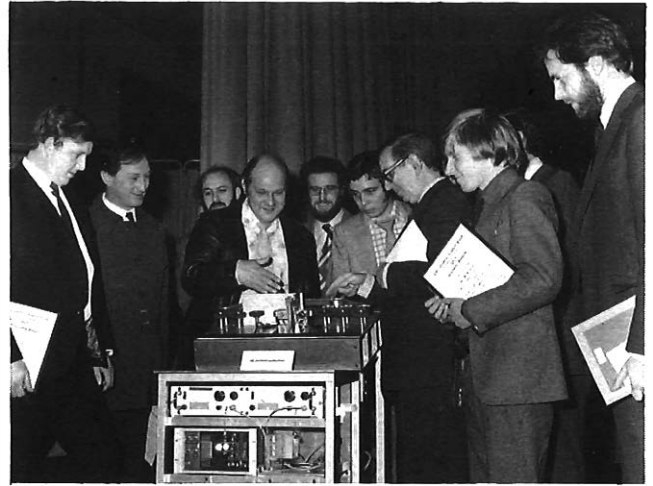

From left to right: R. J. Bates, H. E. Crisp, A. J. Wright, P. J. North, R. Hooper-Greenhill, J. K. Williams, Professor Merriman, M. H. Reeve, Dr. J. Grierson, and Dr. I. Garrett

The Gordon Radley Fund dates from 1955, when the Christopher Columbus International Communications Prize was awarded by the City of Genoa jointly to Sir Gordon Radley, then Director General of the BPO, and to Dr Mervin Kelly, President of Bell Telephone Laboratories, New York, for their work on the first Atlantic telephone cable. The Genoese intended that the prize should also reward the scientists, research workers and technicians who contributed to the planning, manufacture and installation of the world's first transoceanic telephone cable.

Sir Gordon Radley used his share of the prize to found the Christopher Columbus Prize Fund, from which the 2 annual premiums for scientific work and craftsmanship were to be paid as prizes to Research Department staff. Following Sir Gordon's death in 1970, the fund's trustees (the Director of Research and 3 Deputy Directors) gave the fund its present name: the Gordon Radley Fund (Christopher Columbus Prize).

## Copyright

The entire contents of this *Journal* are covered by general copyright, and special permission is necessary for reprinting long extracts, but editors are welcome to use not more than one-third of any article, provided that credit is given at the beginning or end, thus: "From *The Post Office Electrical Engineers' Journal*."

The Board of Editors is not responsible for the statements made nor the opinions expressed in any of the articles or correspondence in this *Journal*, unless such statement is made specifically by the Board.

## Subscriptions and Back Numbers

The *Journal* is published quarterly in April, July, October and January, at 35p per copy, 60p per copy including postage and packaging (annual subscription: £2.40; Canada and the USA: \$6.00).

The price to British Post Office staff is 27p per copy.

Back numbers will be supplied if available, price 35p (60p including postage and packaging). At present, copies are available of all issues from July 1970 to date, with the exceptions of April, July and October 1971 which are now sold out.

Orders, by post only, should be addressed to *The Post Office Electrical Engineers' Journal*, 2-12 Gresham Street, London EC2V 7AG.

Employees of the British Post Office can obtain the *Journal* through local agents.

## Binding

Readers can have their copies bound at a cost of £3.00 including return postage by sending the complete set of parts, with a remittance, to Press Binders Ltd., 4 Iliffe Yard, London SE17.

## Remittances

Remittances for all items (except binding) should be made payable to "*The POEE Journal*" and should be crossed "& Co."

## Advertisements

All correspondence relating to advertisement space reservations, copy, proofs etc., should be addressed to the Advertisement Manager, *The Post Office Electrical Engineers' Journal*, 2-12 Gresham Street, London EC2V 7AG.

## Distribution and Sales

Correspondence relating to the distribution and sale of the *Journal* should be addressed to *The Post Office Electrical Engineers' Journal* (Sales), 2-12 Gresham Street, London EC2V 7AG.

## Communications

With the exceptions indicated above, all communications should be addressed to the Managing Editor, *The Post Office Electrical Engineers' Journal*, NP 9.3.4, Room S 08, River Plate House, Finsbury Circus, London EC2M 7LY.

## Model Answer Books

Books of model answers to certain of the City and Guilds of London Institute examinations in telecommunications are published by the Board of Editors. Details of the books available are given at the end of the Supplement to the *Journal*. Copies of the syllabi and question papers are not sold by *The Post Office Electrical Engineers' Journal*, but may be purchased from the Department of Technology, City and Guilds of London Institute, 76 Portland Place, London W1N 4AA.

# Get more for your money with the ITT 2300.

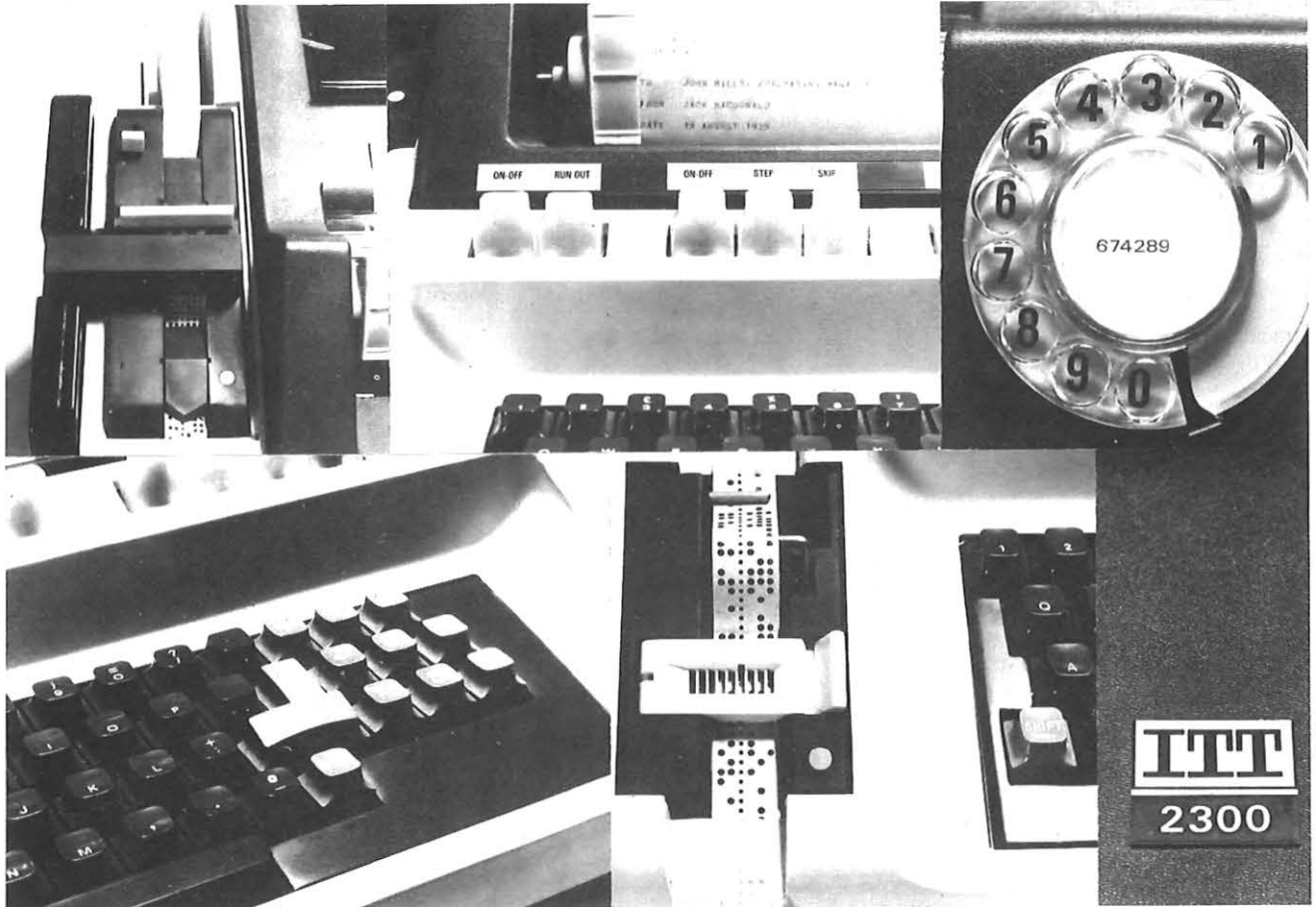

## The teleprinter that's years ahead in design and performance.

The semi-electronic ITT 2300 cuts costs down to size.

It costs less to run because maintenance is simplified, reliability increased, expensive spares holdings minimised and storage space saved. (The number of its mechanical parts has been reduced by two thirds over the previous ITT Creed model.)

All in all, the ITT 2300 offers a speedy return on capital invested.

The ITT 2300 has integrated telex and private wire facilities. It works on all telex systems throughout the world and satisfies technical and safety standards worldwide. All signal processing is electronic.

The ITT 2300 is designed to have many more

operating features than the usual modes. It is adaptable, with built in features that can be adapted to suit individual requirements.

Any typist can operate the ITT 2300, after minimal training. Changing the paper reel and tape roll is easy, and replacing the ink roller cartridge is a clean simple job—so no dirty hands.

The ITT 2300 takes up little more space than a typewriter, making it quite at home anywhere in a modern office.

The ITT 2300.

Tomorrow's teleprinter—today.

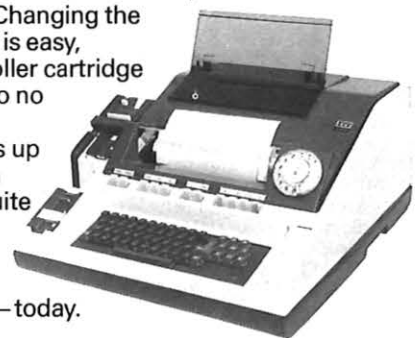

ITT Creed Limited **ITT**



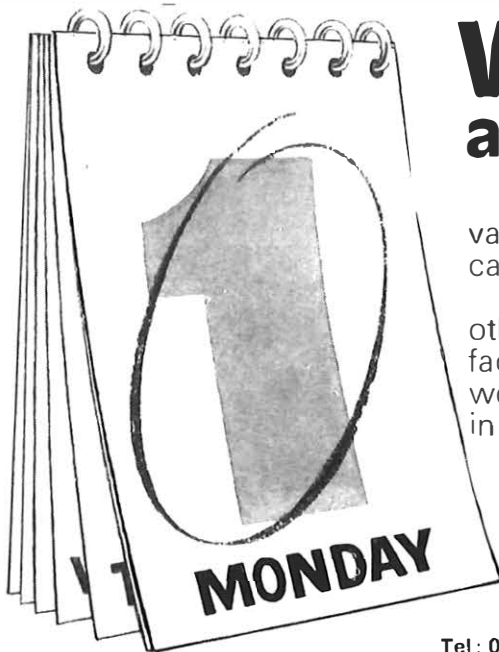

# Working Day any day

From Monday through to Friday, you'll find TCL's vast plant producing more and more telecommunications cable to meet the world's increasing demands.

Typical is the laying-up machine. This and other modern plant are constantly at work in our Dagenham factory, speeding out much of the cable that goes to work for The Post Office, British Rail and similar authorities in countries throughout the world.

But, TCL service stretches beyond the manufacture.

You'll also find our Technical Advisory Staff ready to help at the Planning Stage – ready to supply a working brief any day of the week you want it.



Telephone Cables Limited, Dagenham, England.  
Tel: 01-592 6611. Cables: Drycore, Dagenham. Telex: 896216



### INDEX TO ADVERTISERS

Blue Star Engineering Ltd.	..	..	..	..	..	..	..	..	..	..	..	10
GEC Telecommunications Ltd.	..	..	..	..	..	..	..	..	..	..	..	2, 3
Herman Smith Ltd.	..	..	..	..	..	..	..	..	..	..	..	11
ITT Creed Ltd.	..	..	..	..	..	..	..	..	..	..	..	7
Mullard Ltd.	..	..	..	..	..	..	..	..	..	..	..	5
Oxford University Press	..	..	..	..	..	..	..	..	..	..	..	9
Plessey Telecommunications Ltd.	..	..	..	..	..	..	..	..	..	..	..	1
Record Electrical Co. Ltd.	..	..	..	..	..	..	..	..	..	..	..	4
Telephone Cables Ltd.	..	..	..	..	..	..	..	..	..	..	..	8
Telettra SpA Milan	..	..	..	..	..	..	..	..	..	..	..	6
Top Furniture Ltd.	..	..	..	..	..	..	..	..	..	..	..	9

## Problems and Solutions in Logic Design

D. Zissos

This book describes reliable step-by-step design techniques for the non-specialist. After an introduction to the basic concepts of logic design the chapters deal with unlocked sequential circuits, clocked sequential circuits, counters, and combinational circuits. Over 50 problems with fully worked out solutions demonstrate the design steps. £3.50 paper covers £1.75

**Oxford University Press**

## TOP DISCOUNTS ON TOP QUALITY branded furniture

- Most leading brands.
- Find out now how our Top Discounts and deliveries compare!
- Nationwide service.
- Showroom open.
- Postal and telephone orders welcome.

**TOP FURNITURE COMPANY,**  
83, Parkway, Ruislip Manor,  
Middlesex.  
Tel: Ruislip 36502, 30455 & 36686



# JUST YOUR TYPE!

We design and manufacture precision engineered components and are one of the leading "Post Office approved" suppliers of type 62 practice piece parts and assemblies.

We can also develop a detailed design from your outline drawings and produce to your specific requirements. Please contact us for full details.

## BLUE STAR

Blue Star Engineering Ltd.,  
Arisdale Avenue,  
South Ockendon, Essex.  
Tel : South Ockendon 2223



# Do you know what else Herman Smith can do?

"62" type equipment is the aspect of our output you probably already know about. It's worth remembering however, that we produce many other types of presswork and sheet metal assemblies which may be of use to you.

We are acutely aware of the needs of the electrical and electronics industries and our experience in these spheres is comprehensive.

We are prepared for any challenge, complex or simple, large or small. Try us.

We produce the range of "62" type equipment, including the racks themselves, shelf assemblies, card locks, card guides, slide brackets, dummy front plates, etc. We also undertake electrical and electronic assemblies.



Contact Peter Bowen  
Herman Smith Limited Cinderbank Works Netherton Dudley  
Worcestershire Telephone Dudley 52791

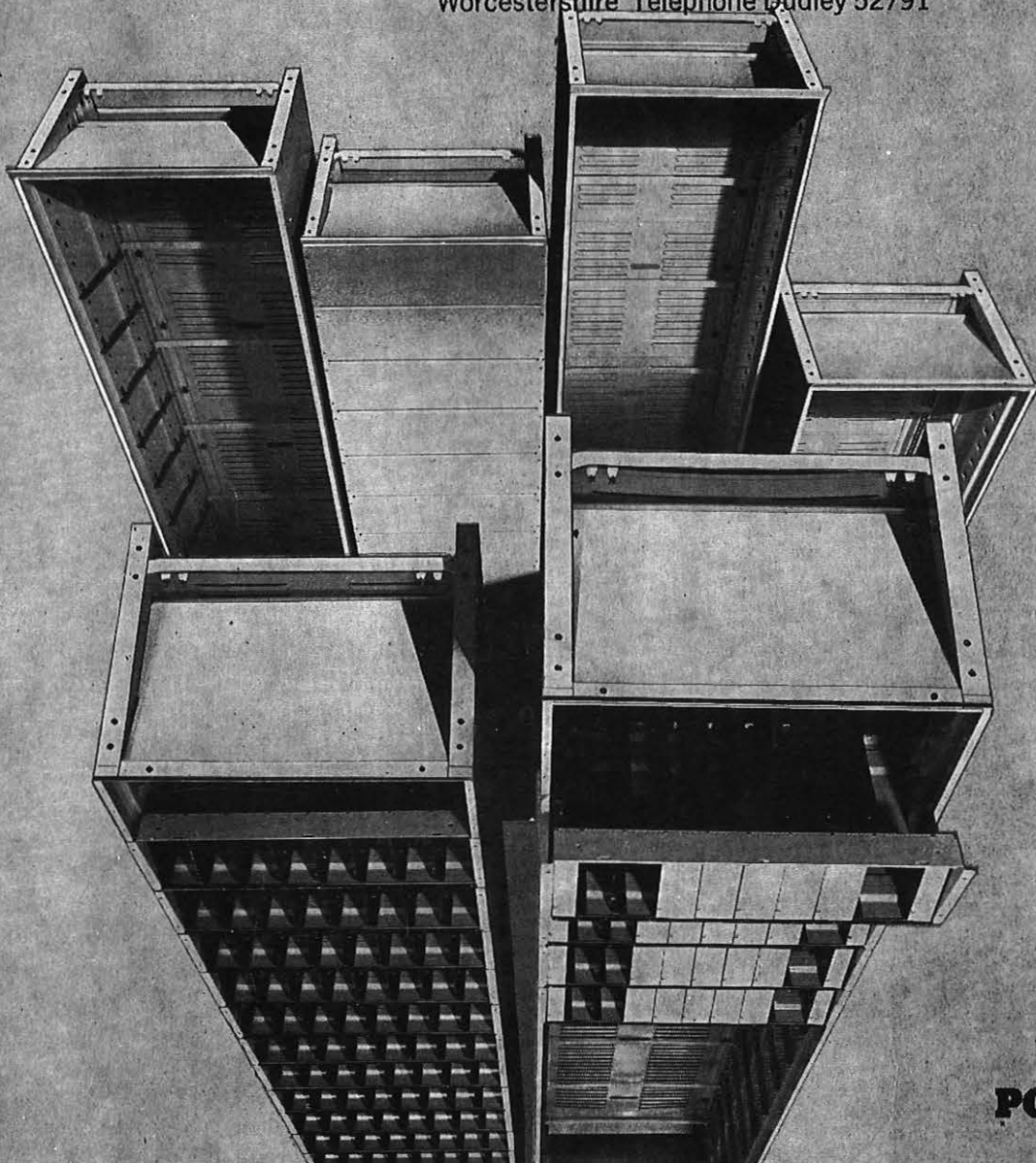

**PO approved**