

# The Post Office Electrical Engineers' Journal

**VOL 68 PART 1 / APRIL 1975**



# THE POST OFFICE ELECTRICAL ENGINEERS' JOURNAL

VOL 68 PART 1 APRIL 1975

## Contents

	<i>page</i>
<b>Editorial</b>	1
<b>Graphical Symbols—D. Price</b>	3
<b>Preliminary Engineering Design of Digital Transmission Systems Using Optical Fibre—R. J. Turner</b>	7
<b>Heating and Ventilating of Telecommunications Buildings</b>	
<b>Part 1—Basic Requirements—H. Williams</b>	15
<b>Experimental Packet-Switched Service: Procedures and Protocols</b>	
<b>Part 2—Transmission Procedures—W. Neil, M. J. Spooner and E. J. Wilson</b>	22
<b>A New Telegraph-Distortion Measuring Set—D. J. Willington</b>	29
<b>Label-Printing Machines in the British Post Office Factories Division</b>	
W. L. Goldie, S. Lifford and A. O. M. Nethercot	35
<b>Support and Protection of Cables—N. E. Fletcher</b>	40
<b>Conference on Plastics in Telecommunications, London, November 1974</b>	
J. C. Harrison	42
<b>A 24-Hour Digital Clock and Alarm Unit—K. Breton</b>	44
<b>New Cable-Repair Ship—CS MONARCH—R. E. G. Back</b>	46
<b>120 Mbit/s Digital Line System Inauguration—G. H. Bennett</b>	47
<b>Variety Control—S. Lifford</b>	49
<b>Regional Notes</b>	55
<b>Associate Section Notes</b>	59
<b>The Associate Section National Committee Report</b>	60
<b>Institution of Post Office Electrical Engineers</b>	61
<b>Notes and Comments</b>	61
<b>Post Office Press Notice</b>	63
<b>Book Reviews</b>	21, 28, 34, 39, 58

Published in April, July, October and January by the *Post Office Electrical Engineers' Journal*,  
2-12 Gresham Street, London EC2V 7AG.

Price: 30p (45p including postage and packaging). Orders by post only.

Annual Subscription (including postage and packaging): Home and Overseas £1·75.  
(Canada and the USA \$4·50.)

Price to British Post Office staff: 21p.

# The quiet answer to your heated exchanges

Temperature Limited, leading British manufacturers of air-conditioning, have collaborated with the Post Office to design and develop air-handling equipment tailored to meet the stringent requirements of the telecommunications industry – in terms of sound level, construction and performance.

The vertical air-handling unit illustrated is one of a series produced by Temperature Limited, specifically to meet these criteria.

- Five basic models (5-20 TR refrigeration ; 3,000-12,000 c.f.m.)
- All units factory piped, wired and tested
- All basic electrical controls, modulating valves, etc, in-built as standard
- Site work limited to the coupling of water, air and electrical services
- High component quality ensures fundamental reliability and minimal servicing
- In-built fault diagnosis
- Unit designed for low noise emission
- Unit flexibility enhanced by wide range of optional features
- 'In-space' or 'Pod' application ensures maximum utilisation of apparatus room floor space

**For full details, please send this coupon now.**



**Temperature**  
LIMITED

192-206 York Road  
London SW11 3SS  
Telephone: 01-223 0511

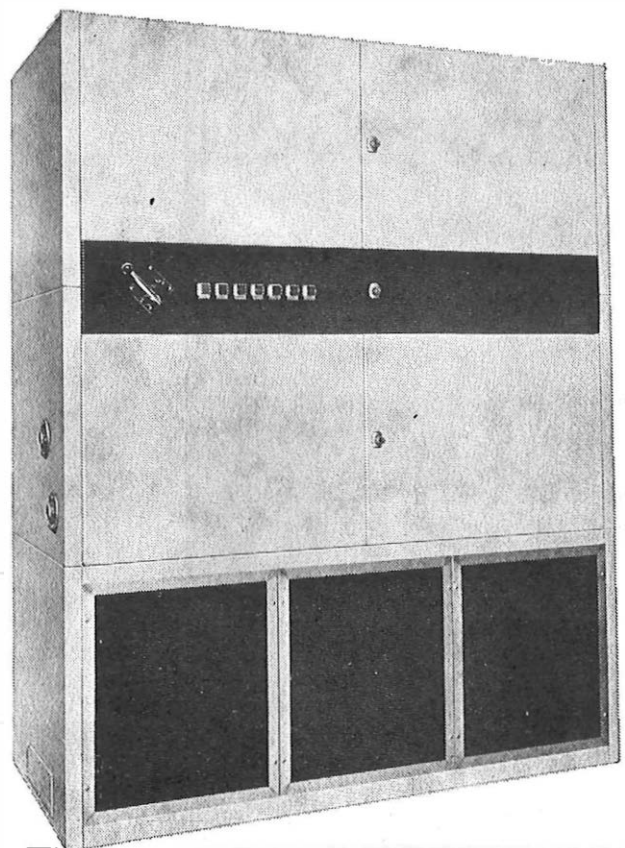

I would like to know more about the Temperature range of air-handling units for the telecommunications industry.

Name .....

Position .....

Company .....

Address .....

.....

.....

POEE 1

## DT30-TM

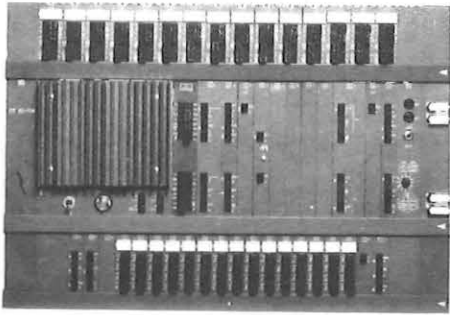

### 30 CHANNELS PCM MULTIPLEX

CCITT-CEPT specification

E/M signalling units or built in  
signalling converters for different  
switching techniques

Facility for data transmission

## DT30-RC

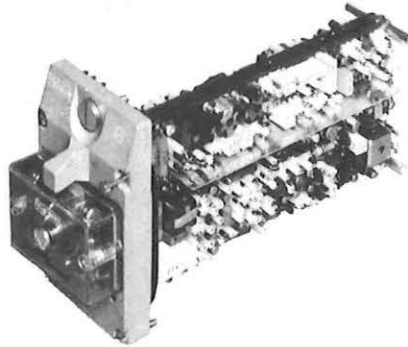
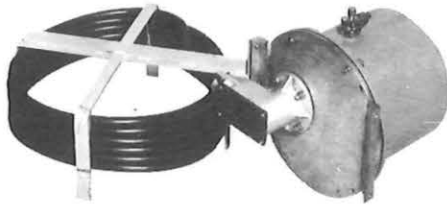

### 30 CHANNELS CABLE LINE OVER SYMMETRICAL PAIRS

Automatic gain control

14 stations remotely supervised  
from each line terminal

Housings in manholes, directly  
buried underground or pole  
mounting

## HI7/30



### 30 CHANNELS DIGITAL RADIO LINK

13 GHz pole mounting radio  
equipment with AM/ON-OFF  
modulation

Radio installation up to 2 km  
apart from multiplex station  
with remote feeding

20 km typical hop

# TELETTRA DIGITAL EQUIPMENTS



## DT8

DT2/8-TM  
DT8/17-TM  
DT8/35-TM

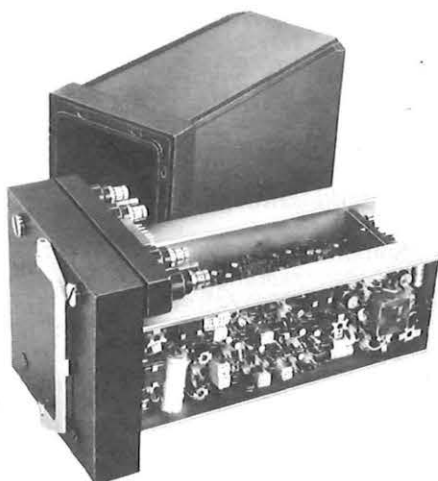

8.448 Mbit/s DIGITAL LINE  
4 km regenerative section over  
microcoaxial (0.65–2.8) or  
screened symmetrical-pair  
cable

100 km remote feeding span  
Range of application extendable  
to 34 Mbit lines with 2 km  
repeater spacing

8.448; 17.152; 34.304 Mbit/s  
DIGITAL MULTIPLEXERS

Digital multiplexers for 2 and  
Mbit/s digital lines (120,  
40 and 480 chs.)

HD2  
HG

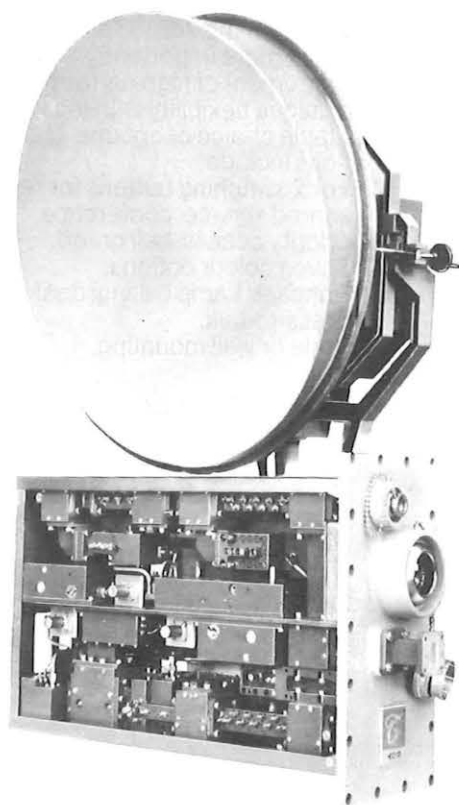

DIGITAL RADIO SYSTEMS  
UP TO 34 Mbit

2- or 4-phase digital  
modulation

Heterodyne scheme

8, 17, 34 Mbit/s transmission

HD2: operating in the 13 GHz  
range

HG: operating within FDM  
CCIR frequency arrangement

over 10 years experience in PCM plant in  
domestic and foreign market

*Telettra* VIMERCATE MILANO ITALY

The GEC 746 table telephone – You can depend on it. That's the most important thing you can say about a telephone, a very essential tool of modern society. Important as it is, it is often taken for granted.

When you buy a telephone you obviously want good styling at a low price. In the 746 we provide both but more importantly we offer an instrument of high performance and unique flexibility with the widest available choice of options. These options include:

- \* 1 or 2 switching buttons for recall, shared service, conference, priority access, bell on/off.
- \* Seven colour options.
- \* Handset: Lamp calling; deaf aid; press-to-talk.
- \* Table or wall mounting.

- \* Dials: 10 or 20 i.p.s; dial lock; C.B. working. Number rings – to suit any requirement. Pushbutton signalling – three versions available: Self-contained MOS loop disconnect for all types of exchange. Multifrequency for large exchanges. D.C. leg for PAX/PABX exchanges.
- \* Ringer: High or low impedance. Extension Bell.
- \* Automatic volume regulator optional.
- \* Line cord 1.5 m, 2 m, 3 m Plug or Jack.

Someone, somewhere may think they have a requirement that cannot be met by the GEC 746 range. We'd welcome the chance to prove them wrong.

GEC manufacture telephones for world markets: table and wall-mounting models in a number of attractive colours, loudspeaking telephones, pushbutton telephones and switching telephone systems.

Dial or pushbutton versions available for all telephones.



**You couldn't be in better hands.**

GEC Telecommunications Ltd.,  
Telephone Division, Whinbank Road, Aycliffe,  
Co. Durham, England.  
A Management Company  
of The General Electric  
Company Ltd. of England.



**Always at hand.  
The GEC 746 table telephone  
-you can depend on it.**

# At your fingertip. Two or three telephones on one exchange line and an intercom system all in one.

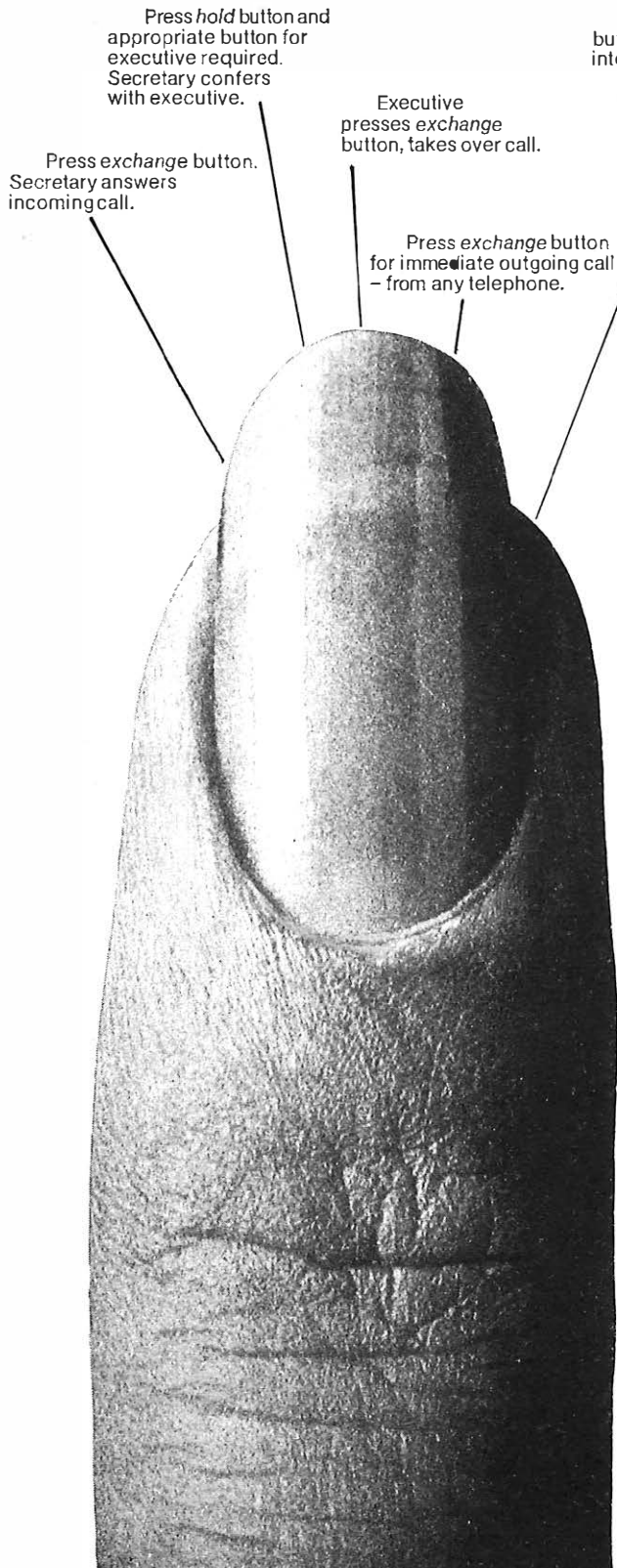

Press *hold* button and appropriate button for executive required. Secretary confers with executive.

Press *exchange* button. Secretary answers incoming call.

Executive presses *exchange* button, takes over call.

Press *exchange* button for immediate outgoing call - from any telephone.

Press appropriate button, 1 or 2 for intercom system.

## The versatile GEC 740 switching telephone.

There's more to the GEC 740 switching telephone than meets the eye . . .

On one hand it provides independent access to a single exchange line from two telephones (1/2 system) or three telephones (1/3 system).

On the other, it is a separate intercom system—keeping exchange calls secret from internal calls. And it's all in one basic instrument—controlled by push-button switches in front of the hand-set on each 'phone. Neat, simple to use—but extremely versatile.

Dial or pushbutton versions available for all telephones.

GEC manufacture telephones for world markets: table and wall-mounting models in a number of attractive colours, loudspeaking telephones, pushbutton telephones and switching telephone systems . . .



### You couldn't be in better hands.

GEC Telecommunications Ltd.,  
Telephone Division, Whinbank Road,  
Aycliffe, Co. Durham, England.

A Management Company of  
The General Electric  
Company Ltd. of England.

# Any weather, any climate, GEC take radio efficiency to extremes

In the Chilean  
High Andes

Take the GEC 2GHz system. So adaptable, it is already operating successfully in various extremes of temperature and humidity – from the arctic regions of Canada to the Swiss Alps, and from the deserts of Libya and Bahrain to the tropical conditions of Nigeria and Zambia.

The GEC 2GHz system provides high system planning flexibility with complete band coverage from 1.7 to 2.3 GHz, with a capacity of 960 telephone circuits, or one colour television channel and one sound channel. Completely semiconductor, the equipment, which is in accord with CCIR recommendations, combines high reliability with low power consumption making it particularly dependable for routes which must cross remote or difficult areas. Its modular construction, the latest example of systematic improvement to a successful and proven system, reduces field maintenance to a minimum and enables qualified maintenance engineers to work from a strategically located central depot. System-planning engineers will be pleased to show you some of the other ways in which the 2GHz system has already proved extremely successful in 18 countries.

Total telecommunications: Microwave and Line Transmission, Multiplex, V.F. Telegraphy, Data Modems, Public Exchanges, Private Telephone Systems, Telephones, Total Systems Capability.

## GEC

GEC Telecommunications Limited  
of Coventry, England.  
A Management Company of The  
General Electric Co. Ltd. of England.

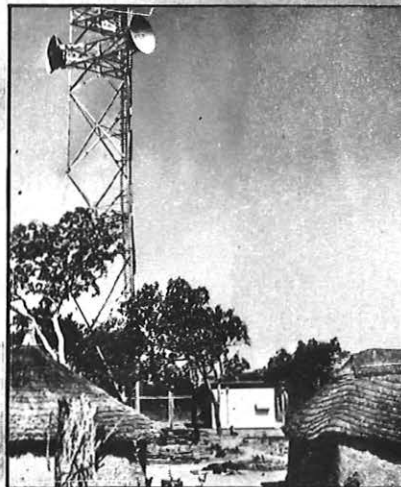

In the Nigerian Bush



In the Swiss Alps

# The Post Office Electrical Engineers' Journal

---

## BOARD OF EDITORS

J. F. P. Thomas, B.SC., C.ENG., M.I.E.E., Chairman  
E. W. Ayers, B.SC.(ENG.), C.ENG., F.I.E.E.  
A. J. Barker, C.ENG., F.I.E.E.  
A. J. Barnard, C.ENG., M.I.E.E.  
C. E. Clinch, B.SC.(ENG.), C.ENG., F.I.MECH.E., F.I.E.E., F.S.S.  
J. Martin, B.SC.(ENG.), C.ENG., M.I.E.E.  
A. Ness, C.ENG., M.I.E.E.

## Managing Editor

D. Millington, C.ENG., M.I.E.E.

## Assistant Editor

B. Stagg

## Secretary-Treasurer

B. Farr

## Advertisement Manager













































































R. G. Rothery

## EDITORIAL

From this issue onwards, all drawings in the *Journal* will be drawn using the symbols and standards laid down in the British Standards Institution's BS 3939: *Graphical Symbols for Electrical and Electronics Diagrams*. Some of these symbols may be much less familiar to many readers than the symbols previously used, but it is important that they become well known, as it is now British Post Office (BPO) policy to use BS 3939 symbols on all new drawings. To assist further, the first article in this issue of the *Journal* describes the development of the BS 3939 symbols, gives the requirements which they must meet and includes many examples of the new symbols.

Other changes are also being made to the *Journal* from this issue onwards, including the use of BPO standards for abbreviations in the text and the publication of the Supplement in alternate 32-page and 16-page sizes, the latter yielding printing economies compared with the 24-page size used previously in each issue. This issue of the Supplement is, therefore, 32 pages long, giving the added advantage to readers that the answers to some 1974 City and Guilds of London Institute examinations are published in April 1975 instead of July 1975 and are, therefore, available before the 1975 examinations are held.

In addition to the article on BS 3939 symbols, this issue includes articles on many varied topics, ranging from the last of the series on optical-fibre transmission systems to the heating and ventilating of telecommunications buildings, and from the launching of cable ships to the label-printing activities of the BPO Factories Division.

DESCRIPTION	BS 3939 NUMBER	SYMBOL	DESCRIPTION	BS 3939 NUMBER	SYMBOL
VARIABILITY	1·3·4-6	 INHERENTLY AUTOMATIC  CONTINUOUSLY VARIABLE  VARIABLE IN 5 STEPS	MECHANICAL CONTROL: LATCHING DEVICE	1·5·5-6	 In unlatched position  In latched position  UNI-DIRECTIONAL  BI-DIRECTIONAL
TYPES OF PULSE MODULATION	1·8·3-4 AND 1·8·6	 PULSE-AMPLITUDE MODULATION  PULSE-DURATION MODULATION  PULSE-CODE MODULATION	EARTH AND CHASSIS CONNEXIONS	2·2·1-3	 EARTH  NOISELESS (CLEAN) EARTH  FRAME OR CHASSIS
MISCELLANEOUS	2·3·6-8	 IMPEDANCE  PERMANENT MAGNET  RECTIFIER	WARNING AND INDICATING DEVICES	2·4·1 AND 2·4·5-6	 INDICATOR  SIGNAL LAMP  ELECTROLUMINESCENT DEVICES
CROSSINGS AND CONNEXIONS OF CONDUCTORS	3·5·1 AND 3·5·4-5	 CROSSING (with no electrical connexion)  CONNEXION COMMON TO A GROUP OF APPARATUS  COMMON POINT (with minimum common impedance)	PLUGS AND SOCKETS	3·8·1-4	 PLUG (MALE)  SOCKET (FEMALE)  COAXIAL PLUG  COAXIAL SOCKET
PLUGS AND JACKS	3·9·1-3	 PLUG  JACK SLEEVE (BUSH)  JACK SPRING  3 POLE CONCENTRIC PLUG AND JACK	MISCELLANEOUS CONNECTING DEVICES: FUSES	3·10·3 AND 3·10·6	 GENERAL SYMBOL  SUPPLY SIDE INDICATED BY THICK LINE  WITH ALARM CONTACT (3-terminal)
FIXED RESISTORS	4·1·1, 4·1·5 AND 4·1·9	 GENERAL SYMBOL  FIXED RESISTOR WITH FIXED TAPPING (voltage divider)  HEATER	VARIABLE RESISTORS: NON-INHERENT AND INHERENT	4·2·1, 4·2·3 AND 4·3·1	 VARIABLE RESISTOR: GENERAL SYMBOL  RESISTOR (with preset adjustment)  RESISTOR (with inherent non-linear variability)
CAPACITORS	5·1·1, 5·1·4 AND 5·2·1	 GENERAL SYMBOL  CAPACITOR WITH INHERENT SERIES RESISTANCE  VARIABLE CAPACITOR GENERAL SYMBOL	INDUCTORS AND TRANSFORMERS	6·1·1 AND 6·1·4-5	 WINDING GENERAL SYMBOL  INDUCTOR (with ferromagnetic core)  TRANSFORMER GENERAL SYMBOL
RELAY COILS	11·1·11-12 AND 11·1·15	 REMANENT RELAY  POLARIZED RELAY  MECHANICALLY-LATCHED RELAY	CONNECTING STAGE	13·1·2 AND 13·1·14	 WITH INLETS AND OUTLETS: GENERAL SYMBOL  SWITCHING STAGE CONSISTING OF ONE CONNECTING STAGE
ELEMENTS OF SELECTORS	13·2·1, 13·2·3-5, 13·2·7 AND 13·2·15	 NON-BRIDGING WIPER  BRIDGING WIPER  SELECTOR ARC: GENERAL SYMBOL  SELECTOR ARC (showing groups of outlets or contacts)  SELECTOR ARC (showing individual outlets or contacts)  OPERATING COIL OF SELECTOR (selector magnet)	SELECTORS FOR USE ON SINGLE-LINE AND TRUNKING DIAGRAMS	13·3·1, 13·3·3-5 AND 13·3·11	 SELECTOR LEVEL (with bridging wiper)  SINGLE-MOTION SELECTOR: NON-HOMING  SINGLE-MOTION SELECTOR: HOMING  TWO-MOTION SELECTOR  TWO-MOTION SELECTOR (showing individual levels)
CROSSBAR SELECTORS	13·4·1-3	 GENERAL SYMBOL  ONE CONNECTING UNIT OF CROSSBAR SELECTOR  CROSSBAR SELECTOR FOR 4-WIRE SWITCHING	DIODE DEVICES (Note: symbol may include the envelope symbol)	20·5·1, 20·5·5-6 AND 20·6·1	 p-n DIODE: GENERAL SYMBOL  TUNNEL DIODE  UNIDIRECTIONAL BREAKDOWN DIODE, VOLTAGE-REFERENCE DIODE (e.g. Zener diode)  THYRISTOR: GENERAL SYMBOL
TRANSISTORS (Note: envelope may be omitted except where connexion is made to it; e.g. 20.7.2)	20·7·1-2 AND 20·8·7	 pnp TRANSISTOR (Also pnp transistor if omission of intrinsic region does not result in ambiguity)  npn TRANSISTOR (with collector connected to envelope)  INSULATED-GATE FIELD-EFFECT TRANSISTOR (2-gate, n-channel, 5-terminal with substrate connexion brought out)	BLOCK SYMBOLS	22·3·6, 22·4·1, 22·6·1, 22·7·5 AND 22·8·1	 FREQUENCY CHANGER (changing from $f_1$ to $f_2$ )  AMPLIFIER  ATTENUATOR, FIXED LOSS (PAD) (Note: numerical value of attenuation may be added)  ASYMMETRIC (SKEW) HYBRID TRANSFORMER (shown with balancing network)  MODULATOR, DEMODULATOR, OR DISCRIMINATOR

Selection of symbols from BS 3939



# Graphical Symbols

D. PRICE†

U.D.C. 003.62: 621.3

*A revised standard of graphical symbols for electrical and electronics diagrams was published by the British Standards Institution in 1966. The development of these symbols is described, some of the requirements which symbols must meet are given and a table is included showing many examples of symbols.*

## INTRODUCTION

In 1966, the British Standards Institution (BSI) published the first sections of *BS 3939: Graphical Symbols for Electrical and Electronics Diagrams*. This standard now consists of 28 sections and it replaces 2 earlier standards, *BS 108: 1951, Graphical Symbols for General Electrical Purposes* and *BS 530: 1948, Graphical Symbols for Telecommunications*.

The revision of the publications was made necessary by the need to keep the recommended symbols up to date in the rapidly developing electrical and electronic fields and to achieve, as far as possible, uniformity in the symbols used by both the heavy-current and light-current electrical industries. This latter point became important with the greater use of electronic devices in the control of heavy engineering plant and in the regulation of power supplies.

British Post Office (BPO) policy is to accept British Standards as far as possible and, thus, all new electrical and electronic diagrams should be drawn to BS 3939, and existing diagrams changed to agree with this standard whenever redrawing is necessary. Following this lead, the Board of Editors have decided to use BS 3939 symbols in the *Journal* in the future.

This article sets out to give some information on the development and requirements of the symbology relating to the electrical and electronics fields, describes the organizations whose task is to obtain national and international agreement on symbols and includes a table on the opposite page showing some of the symbols which are in common use.

## GENERAL

### Pictorial Symbols

The first symbols used in drawing circuit diagrams were mainly of a pictorial type. Thus, the reader was able to identify a component by looking for a picture of it on the diagram. Fig. 1 shows 3 examples of pictorial symbols.

This form of representation presented several difficulties. The symbols were often awkward to draw and, as techniques changed and the function to be represented could be realized by one of several devices, so the outline of the component gave little indication of its use. For example, in current practice, capacitance may be provided in a circuit by several different methods; these include 2 metal plates with air separation, 2 strips of metal foil with a paste dielectric, a semiconductor device or the inherent capacitance between individual turns of a coil.

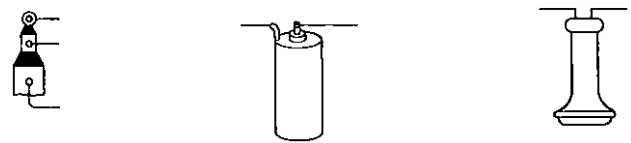

FIG. 1—Examples of pictorial symbols

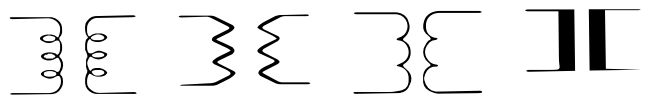

FIG. 2—Symbols for a transformer

### Development of Symbols

To avoid these difficulties, symbols were developed, often in pictogram form, which tried to convey the function of the device rather than the practical construction. Unfortunately, the development of the symbology progressed at different rates nationally and internationally, due partly to the separate development of individual designs of equipment and partly to different drawing methods. Thus, several different forms of the same symbol came to be used concurrently.

### Standardization of Symbols

It was recognized early that standardization of symbols was very desirable, and members of standards organizations have worked hard to achieve this object, the BPO playing an important part both nationally and internationally.

To secure wide agreement on symbols means that well-established national and individual usages must often change. There is inevitably resistance to the change and the process, therefore, takes a long time. A new symbol may not be recognized by the maintenance officer and delay in restoring faulty equipment to normal service could result. The need for agreement can be seen from the symbols for a transformer shown in Fig. 2, which are taken from the standards of 4 different countries.

† Telecommunications Development Department, Telecommunications Headquarters.



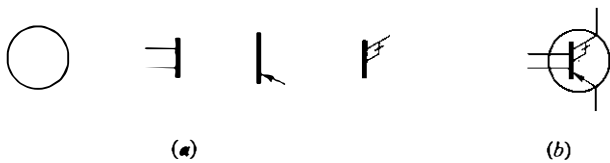

(a) Elemental symbols (b) Combined symbols

FIG. 3—Symbol for a *p n i n* transistor with ohmic connexion to the *i* region

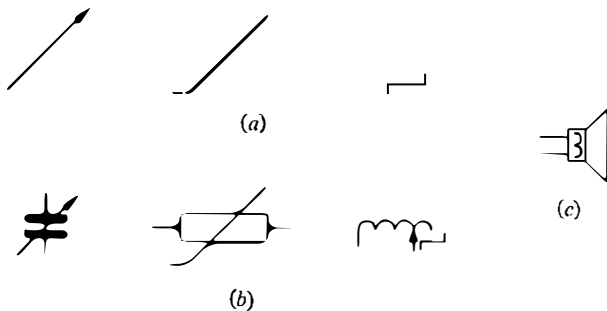

(a) Qualifying symbols (b) Examples of qualifying symbols being used (c) Use of coil symbol to indicate moving-coil type loudspeaker

FIG. 4—Use of qualifying symbols

The BSI appreciated that there would be difficulties caused by changing existing symbols and BS 3939, therefore, shows the objective and existing forms of symbols where these differ. The objective symbol is that which has been agreed by the International Electrotechnical Commission (IEC), and is the one to be adopted as soon as possible. Established usages in this country, however, can make this form unacceptable to some designers and readers at the present time, and it is obviously undesirable to change to a different form of symbol when a diagram is being amended rather than redrawn. It is BPO policy to use the objective symbols for all new work.

To obtain international agreement, a joint working group of the IEC, the CCITT\* and the CCIR† was formed in 1963, with representatives from several countries, including the UK. Proposals for new or amended symbols are made by the working group and sent to the parent organizations. The IEC, after consideration by the appropriate technical committee, includes the symbols in IEC Publication 117. This document provided the basis for BS 3939, and the standard is updated from time to time to follow the amendments to Publication 117. The BPO officers, by virtue of their membership of the appropriate BSI committees, are able to assist in the national and international work involved. The BPO Terms and Symbols Committee provides the framework for the representatives to ascertain the views of other members of the staff on the new symbols and, thus, be able to offer authoritative BPO comments to the BSI committees concerned.

## SYMBOL DESIGN

### General

In devising symbols, the most important requirements to be considered are that they should be easy to understand and remember, be generally acceptable to the user and be capable of being drawn with the minimum of difficulty.

\* CCITT—International Telegraph and Telephone Consultative Committee.

† CCIR—International Radio Consultative Committee.

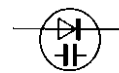
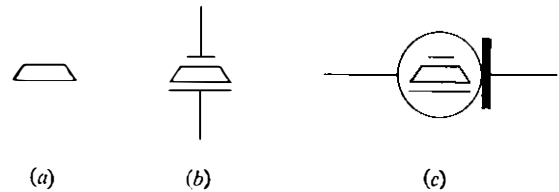

FIG. 5—Symbol for a *p n* diode used as a capacitive device



(a) Electret material (b) Electret with connexions (c) Electret microphone

FIG. 6—Proposed symbol for the electret



FIG. 7—Examples of similar symbols of different sizes

To be understood and remembered, the symbols should, where appropriate, bear some obvious relationship to the existing convention for the function to be symbolized; for example, a magnetic amplifier is a type of amplifier and the symbol should include the triangular shape recognizable as representing an amplifier. However, the symbols have to be drawn, possibly using stencils, and also have to be reproduced economically. Therefore, small details, acute angles, very close lines and large filled-in areas should be avoided.

As far as possible, the symbol should be built up from existing symbols for the elements of the device. Thus, the symbol for the *p n i n* transistor shown in Fig. 3(b) has been assembled from the symbols in Fig. 3(a). These represent an envelope, a semiconductor region with 2 ohmic connexions, a *p* emitter on an *n* region, and an intrinsic region between a collector and a region of similar conductivity.

The possible development of the device to be symbolized should be considered, and the symbol so devised that it can be easily amended to take account of future forms of the device. For example, the symbol for a triode valve allows the easy addition of the symbols for the extra grids in a pentode valve.

### Qualifying Symbols

Qualifying symbols may be added to a component symbol when it is necessary to give the reader more information concerning the device than is provided by the general symbol. They may be added to indicate variability, voltage dependence, signal flow and similar functions. Qualifying symbols should not be used independently, but where appropriate, component symbols can be used as qualifying symbols. Figs. 4(a) and 4(b) show some examples of qualifying symbols and their uses. Fig. 4(c) shows an example of the component symbol for a coil used to indicate that a loudspeaker is of the moving-coil type.

It is sometimes necessary, in a circuit, to use a component for a purpose other than that suggested by the normal symbol. In this case, the symbol representing the desired function should be shown as a qualifying symbol usually to a smaller scale and may be enclosed in the envelope of the normal symbol if this is shown. An example of a  $p-n$  diode used as a capacitive device (varactor) is shown in Fig. 5.

### The Electret

The proposed symbol for an electret illustrates the application of some of the points in this section. Fig. 6(a) shows the proposal for the symbol for electret material, Fig. 6(b) the electret with connexions and Fig. 6(c) the electret microphone. The symbol was developed from the symbol for a capacitor, the unequal length of the plates representing the different polarity in the same manner as in the symbol for a primary or secondary cell.

### Size of Symbols

The size of the new symbol should be compatible with those in BS 3939, which are the minimum desirable for final prints made by normal economic reproduction methods, and which are the same size as that used for the diagrams of individual BS 3939 symbols in this article. Smaller-sized symbols are permitted when better-quality reproduction is used; for example, in handbooks and magazines, and the size of symbols that will generally be used in this *Journal* is shown in Figs. 10, 13 and the table on page 2.

Some symbols in BS 3939 are larger than other similar symbols. This is because information to be included inside the outline would otherwise be too small. An example is given in Fig. 7 of 2 meters. The ammeter symbol uses a normal-sized circle, but the power-factor meter symbol is increased in size to include the  $\cos \phi$ .

### Use of Letters in Symbols

If it is necessary to include letters in a symbol, those accepted internationally should be used rather than a national abbreviation which may not be appropriate in other languages. Fig. 8 shows a frequency meter using the letter symbol for frequency (Hz) and a wavemeter using the letter symbol for wavelength ( $\lambda$ ), both accepted by the IEC. In this example, it is much better to use the internationally-accepted letter, *lambda*, rather than an abbreviation such as **W** for the word *wavemeter* which in 8 other languages is spelt *ondemètre*, *wellenmesser*, *ondámetro*, *ondametro*, *golfineter*, *salomierz*, *vågmeter*, and *волномер*.

Similarly, it would be difficult for a person who could speak only English to recognize the meaning of the Rumanian symbol for a fire station in Fig. 9.

## USE AND LAYOUT OF SYMBOLS

### General

Many diagrams are large and complex and it is very desirable that the reader should be helped as much as possible to trace the signal flow and to understand the circuit operation.

Readers of written material do not normally see one letter at a time and, depending on their skill, can read a word, phrase or even a line at one time. Similarly, when reading a diagram, if the drawing and layout are correctly carried out, it should be possible in most cases to grasp the circuit operation without having to look at each individual symbol. The degree of success depends on the knowledge and skill of the draughtsman, and on the expertise of the reader and his familiarity with the particular type of circuitry.

There are 2 main aids to rapid comprehension. As far as possible, components should be placed in the order in which

the signal flows, and the components should be arranged in easily recognizable groups. In practice, the 2 objectives may conflict and difficulties may arise when a component or group of components is used in different ways during various stages of circuit operation. Inevitably, the final layout will be a compromise. Fig. 10 shows some typical groupings of components.



FIG. 8—Examples of symbols which include letters



FIG. 9—Block symbol for *Centrală de incendiu*



COMPONENTS IN PARALLEL

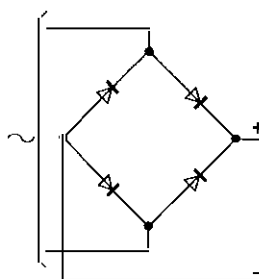

SINGLE-PHASE BRIDGE RECTIFIER

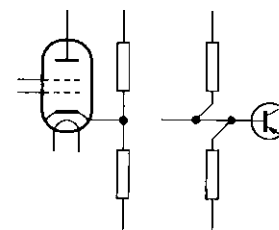

BIASING OF VALVES AND TRANSISTORS

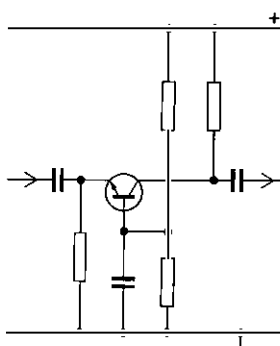

COMMON-BASE RC COUPLED AMPLIFYING STAGE

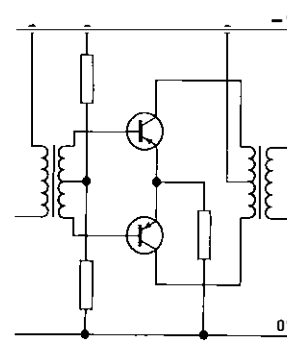

TRANSFORMER COUPLED PUSH-PULL AMPLIFYING STAGE

FIG. 10—Examples of groups of components and recommended layouts

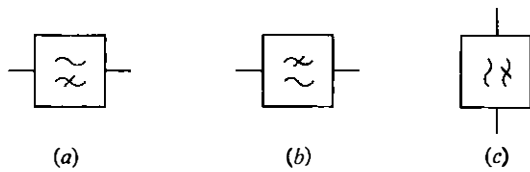

(a) Correct (b) Inverted (c) Rotated through 90°  
 FIG. 11—The effect of rotating the symbol for a high-pass filter



FIG. 12—Examples of symbols which imply a direction of signal flow

### Orientation

Generally, the orientation of the symbols should follow that of the lines representing conductors; that is, horizontal or vertical. However, the meaning of some of the symbols is changed if they are rotated. Fig. 11(a) shows the correct symbol for a high-pass filter; Fig. 11(b) shows the same symbol inverted. It is now indistinguishable from that for a low-pass filter. Fig. 11(c) shows the symbol in Fig. 11(a) rotated through 90°. It could be read as either a high-pass or low-pass filter in this position.

Some symbols imply a direction of signal flow; for example, the block symbol for an amplifier or an equalizer. Fig. 12 shows these items and includes directional arrows. The symbols must be used always in the correct sense, although it is not necessary to include the arrows.

### Omitting Lines

When a line representing a conductor has to pass from one part of a diagram to another part some distance away, the line may be omitted and the connexion indicated by a reference. Similarly, this convention can be used when a line passes from one sheet of a diagram to another sheet. Fig. 13 gives examples of both these applications.

### Wiring Junctions

Wires connected together should be shown as in Fig. 14(a) and (b), but *not* as shown in Fig. 14(c). The practice illustrated in Fig. 14(a) and (b) follows BS 3939, and the dots should not be omitted.

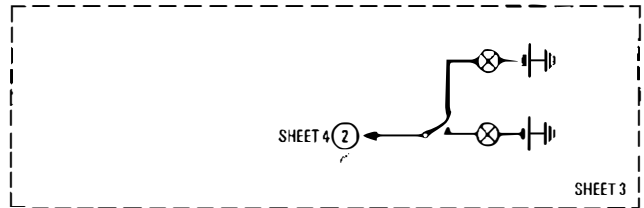
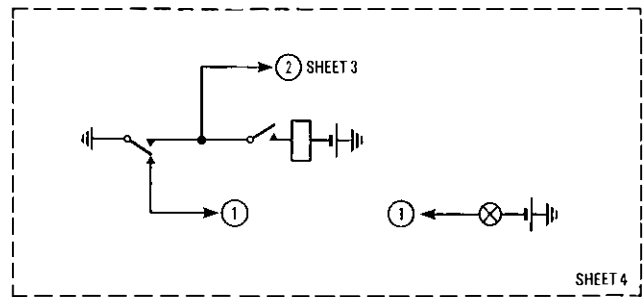
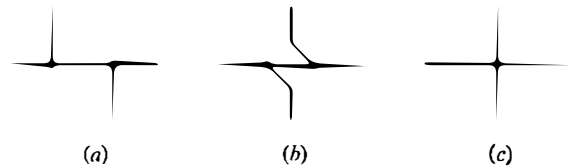

FIG. 13—Example of a circuit in which the lines representing 2 conductors have been replaced by references



(a) and (b) Correct (c) Incorrect

FIG. 14—Methods of showing single and double junctions

### EXAMPLES OF SYMBOLS

BS 3939 includes over 1400 symbols, many of which are the same as in the earlier standards (BS 108 and BS 530); others have been changed to agree with the IEC Recommendations. A selection of the symbols from BS 3939 is shown in the table at the beginning of this article.

### CONCLUSIONS

In this article, it has been possible to describe only a few of the requirements which symbols must meet, and to give some details of layouts and symbol groupings. The article has concentrated on the changed symbols, rather than the many in common use which already follow international standards. Further information on this subject, and details of other symbols, may be obtained from BS 3939 and the appropriate BPO requirement specification (POR 9953).

# Preliminary Engineering Design of Digital Transmission Systems Using Optical Fibre

R. J. TURNER, B.SC.(ENG.), PH.D., M.I.E.E.†

U.D.C. 621.395.4:621.391.63:681.327.8

*Tentative system designs are obtained in this article at 2, 8, 34, 140 and 565 Mbit/s for systems using, as appropriate, light-emitting diodes (LEDs) with multimode fibre or lasers with monomode fibre. These show that the laser-monomode fibre system could become competitive with digital coaxial-cable systems at 140 and 565 Mbit/s, even if the fibre cable (including the power-feed cable) is as expensive as the equivalent coaxial cable. The LED-multimode fibre system could become competitive at 2 and 8 Mbit/s with digital systems using newly-installed metallic-pair cables, when the cost of the fibre cable is of the same order as the pair cable. Important factors in this case could be the avoidance of most buried repeaters and the saving of duct space.*

## INTRODUCTION

Optical-fibre transmission systems are being considered for use in the trunk and junction networks on a digital basis; they might also be of use in distributing high-bit-rate services to subscribers. In addition, they are being considered for use, on an analogue basis, in closed-circuit television systems for a variety of applications.

A previous article<sup>1</sup> in this series described the general principles of optical-fibre transmission systems and others<sup>2,3</sup> indicated, in more detail, the properties and limitations of the optical-fibre transmission line. Further articles give details of the optical sources<sup>4</sup> and the optical detectors<sup>5</sup> that could be employed. This article reviews the properties of sources, detectors and optical fibres in terms relevant to system design, and then obtains relationships between the loss of the fibre and the resulting signal-to-noise ratio in a form suitable for determining the advantages and disadvantages of optical-fibre systems relative to present and future metal-conductor systems. The distance between repeaters is of particular interest in this context. Two main types of optical-fibre system are being considered. Systems using light-emitting diodes (LEDs) and multimode fibre are suitable only for relatively low bit rates, whilst those using lasers and monomode fibre will be suitable for all bit rates. Most attention is

given in this article to the LED-multimode-fibre system, for which component development is most nearly ready.

The basic items of equipment required for a digital transmission system are

- (a) a source of optical power, which can be modulated to indicate a *mark* or a *space* condition and from which optical power can be launched into an optical fibre,
- (b) an optical-fibre transmission line of adequate bandwidth and low enough loss, and
- (c) a detector of optical signals giving adequate sensitivity.

The baseband digital equipment<sup>6</sup> required consists of a drive amplifier for the LED or laser, a low-noise amplifier following the photodiode, a timing extraction circuit and a decision circuit (Fig. 1).

The wavelength for operating systems is likely to be in the range 800–900 nm, for a combination of reasons given below.

The absorption loss of silicate glasses and fibres is a multi-peaked function of wavelength,  $\lambda$ . The scatter loss is proportional to  $\lambda^{-4}$ . One or more minima of total loss occur in the near infra-red wavelength region (approximately 700–1400 nm). Gallium-arsenide (GaAs) and gallium-aluminium-arsenide (GaAlAs) LEDs and lasers can provide compact and reasonably efficient sources in the wavelength range 850–900 nm, and can be directly modulated. The neodymium laser operates at wavelengths of about 1060 nm, but needs to be pumped with a source of optical power, such as an

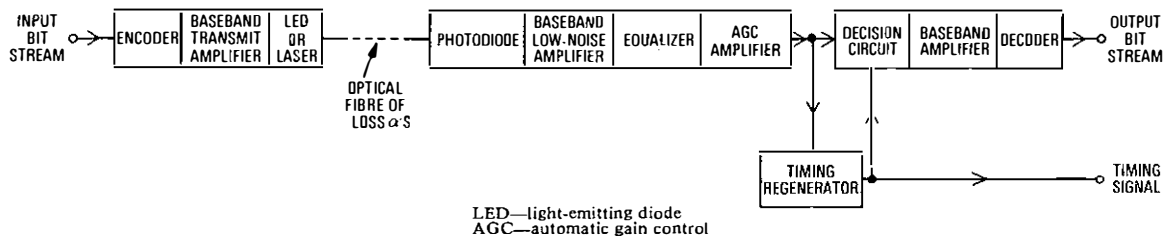

FIG. 1—Outline block diagram of digital optical-fibre transmission system

† Research Department, Telecommunications Headquarters.

LED, and needs a separate optical modulator. Silicon photodiodes have a broad and high peak of sensitivity in the GaAs and GaAlAs emission band; germanium photodiodes have a similar high sensitivity near the neodymium emission band, but have a higher leakage current which, in effect, increases their noise level. The avoidance of loss peaks due to residual hydroxyl ion content in the fibre favours the choice of wavelengths in the 800–850 nm or the 1050–1150 nm ranges.

## PROPERTIES OF SOURCES AND DETECTORS

### Light-Emitting Diodes

In general, the optical power,  $P_{ot}$ , launched from an LED into a fibre is approximately proportional to the LED input current,  $I_i$ , the relationship being given by

$$P_{ot} = K_L I_i, \quad \dots \dots (1)$$

where  $K_L$  is a constant which is a measure of the combined efficiency of the LED and its coupling to the fibre. Digital modulation may be effected by simple ON–OFF keying of  $I_i$ . Analogue amplitude modulation may also be used; the linearity under a.c. conditions (that is, the constancy of  $K_L$  over a range of  $I_i$ ) is then of interest, and a forward bias of about half the maximum swing must be used. If a sinusoidal current,  $i_r$ , is applied to an LED with a suitable d.c. bias, and  $R_D$  is the slope resistance of the voltage/current characteristic of the LED over the swing used, then the relationship between the electrical alternating input power,  $P_i$ , and the alternating component of the optical power,  $P_{ot}$ , launched into the fibre is

$$P_i = i_r^2 R_D = \left( \frac{P_{ot}}{K_L} \right)^2 R_D. \quad \dots \dots (2)$$

At low modulation frequencies, the linearity of the LED in combination with its drive circuit depends upon the impedance of the drive circuit in relation to  $R_D$ , just as it does for a transistor with its drive circuit. As the frequency of  $i_r$  is raised from a low value, it is found that, as with transistors, the junction capacitance,  $C_d$ , and the recombination lifetime,  $\tau$ , of the hole-electron pairs in the transition region bring about a fall in the magnitude and a change in the relative phase of the applied voltage and, hence, a fall in the optical power output. When the LED is modulated by ON–OFF keying, these same effects limit the attainable rise and fall times of the optical output by amounts dependent on the complex impedance of the drive circuit. Thus, if the drive-circuit impedance is very low (constant-voltage drive), the output frequency response is very high and the output transient-response time constant approaches  $\tau$  which, for typical devices, may be of the order of 1 ns. In practice, a compromise drive-circuit impedance must be chosen to optimize power efficiency, linearity and overall frequency or time response.

### Semiconductor Lasers

The GaAs laser can be modulated directly on an ON–OFF basis for digital working. Owing to the threshold effect, the relationship between output optical power into the main mode or modes and input current is inherently non-linear. The threshold current is temperature dependent. There can be a turn-on delay of a few nanoseconds after the laser is switched on by a step of current from zero to a value above the threshold. This delay can be largely eliminated by pre-biasing the laser to a current level close to threshold. The rise and fall times are then less than a nanosecond. The spectral spread for present devices is 2 nm, or less, between half-optical-power points. Present development is aimed at extending the life of the laser and at obtaining efficient coupling to monomode or graded-index fibre.

### Photodiodes

The output current,  $I_r$ , from a reverse-biased photodiode is proportional to the input optical power  $P_{or}$ , and is given by

$$I_r = K_d P_{or}, \quad \dots \dots (3)$$

where  $K_d$  is the photodiode sensitivity which, for a typical commercial device, is about 0.25 A/W. If the photodiode feeds into a load resistance  $R_b$ , and the sinusoidal component of the output current is  $i_r$ , the electrical power in the load,  $P_r$ , is given by

$$P_r = i_r^2 R_b = (K_d P_{or})^2 R_b. \quad \dots \dots (4)$$

In this case,  $P_{or}$  is the alternating component of the received optical power.

Silicon avalanche photodiodes give low-noise amplification of the detected signal, and the sensitivity is increased by 100 times, or more, from a typical unity-gain sensitivity of 0.15 A/W. These devices are operated with a bias voltage approaching their breakdown voltage and so a highly stable bias supply is required. The breakdown voltage of the diode depends on temperature and, hence, the gain varies with temperature; compensation can be provided by feeding the bias supply via a diode having similar characteristics.

An avalanche photodiode has been developed with a breakdown voltage of less than 100 V. It has rise and fall times of about 10 ns and is suitable for low-bit-rate applications. The leakage bias current in the absence of optical power input is known as the *dark current*, and is less than 1 nA in this design. A photodiode with a breakdown voltage of 500 V has rise and fall times of the order of a nanosecond, and is suitable for use in a 140 Mbit/s system. It is necessary to obtain these relatively high-voltage supplies from the series-fed d.c. supply system generally used for buried repeaters. The bias current required is only a few microamperes, and a reliable d.c.–d.c. converter may be a suitable means of supply.

The 3 dB bandwidth of the photodiode circuit,  $f_p$ , is of importance in system design, and is given by

$$f_p = \frac{1}{2\pi R_b C}, \quad \dots \dots (5)$$

where  $C$  is the total capacitance in parallel with the load resistor; this consists of the photodiode capacitance and the input capacitance of the following amplifier.

### OVERALL SYSTEM LOSS

When an optical system is energized by a sinusoidal signal, the relationship between optical-fibre loss and overall electrical-system loss may be obtained from equations (2) and (4) above. The overall loss,  $y$ , in decibels, is given by

$$y = 10 \log_{10} \frac{P_i}{P_r} = 10 \log_{10} \frac{P_i}{P_{or}^2} \left( \frac{P_{or}}{P_r} \right)^2 \frac{P_{or}^2}{P_r} \\ \therefore y = 2\alpha S + 10 \log_{10} \frac{R_D}{K_L^2} \times \frac{1}{K_d^2 R_b}, \quad \dots \dots (6)$$

where  $\alpha S = 10 \log_{10} \frac{P_{or}}{P_r}$ ,

$\alpha$  = loss coefficient of fibre in dB/km, and  
 $S$  = length of fibre between repeaters in km.

The above expression illustrates the peculiarity of the optical system in that a change  $\delta\alpha$  in the optical loss of the fibre corresponds to a change  $2\delta\alpha$  in the overall electrical loss. For instance, an increase  $\delta R_m$  in the signal-to-noise ratio at the decision circuit may be obtained by a decrease  $\frac{1}{2}\delta R_m$  in the loss of the fibre. For the same reason, the electrical bandwidth of a fibre is narrower than the optical bandwidth; the electrical half-power or 3 dB point corresponds to the optical power point which is 0.707 times the maximum power; that is, it is the 1.5 dB optical power point.

## OPTICAL FIBRE

### Material Dispersion Bandwidth

A basic bandwidth limitation that occurs in all optical waveguides results from the combination of optical spectral spread of the source and the dependence of refractive index of the fibre material on the wavelength. If the optical signal is amplitude modulated by a sinusoidal signal, the phases of the signals in the modulation envelope transmitted simultaneously at different wavelengths become unequal at the far end of the fibre as the frequency of modulation is increased, owing to the differing velocities at different wavelengths. The detected amplitude of the modulation at the output of the photodiode decreases, and the effective modulation bandwidth of the system is, thereby, limited. The resulting bandwidth to the 3 dB electrical signal point, which may be termed the *material-dispersion bandwidth*,  $f_d$ , is given by

$$f_d = \frac{f_{dK}}{S\lambda_s}, \quad \dots\dots (7)$$

where  $\lambda_s$  = spectral spread of the source in nanometres between optical half-power points, and

$f_{dK}$  = 3 dB electrical signal bandwidth owing to material dispersion of 1 km of fibre for 1 nm spectral spread of the source.

Typical values of  $f_{dK}$  in GHz km nm are approximately:

silica	3.3
sodium borosilicate	2.4
sodium calcium silicate	1.9
potassium lead silicate	1.2

It is possible that borosilicate glass fibre will be used for system work because it can be produced economically in long lengths to the required specification. The material-dispersion bandwidths for a typical borosilicate glass, in conjunction with the sources likely to be considered, are given in Table 1.

**TABLE 1**  
**Material-Dispersion Bandwidths for a Typical Borosilicate Glass**

Source	Spectral spread between optical half-power points (nm)	Electrical signal bandwidth due to material dispersion (MHz km)
Light-emitting diode	33	70
Laser	2	1200

### Step-Index Multimode Fibre

#### Multipath Bandwidth

Rays, travelling at different angles to the axis of step-index multimode fibre (essentially, in different groups of modes), have different transit times along the fibre, and bandwidth limitation occurs owing to the superposition of the component modulation envelopes at the photodiode. The 3 dB electrical signal bandwidth,  $f_{mp}$ , of a length  $S$  kilometres of such a fibre, assuming ray angles are conserved (that is, mode mixing is absent) over the whole length, is given approximately by

$$f_{mp} \left( \frac{n_1}{n_2} - 1 \right) = \frac{88 \times 10^3}{S}, \quad \dots\dots (8)$$

where  $n_1$  = refractive index of the core, and  
 $n_2$  = refractive index of the cladding.

In the presence of significant mode mixing over long enough lengths of fibre,  $f_{mp}$  tends towards proportionality to  $S^{-1/2}$  rather than  $S^{-1}$ . In system calculations in this article, the pessimistic assumption of bandwidth inversely proportional to length is made.

#### Power Launched into the Fibre

If the area of the active surface of the LED is greater than, or of the same order as that of the core of the fibre, then an approximate relationship for the optical power,  $P_{oi}$ , launched into the fibre butted-up to the active area of the LED is given by

$$P_{oi} = 2\pi A_c R n_2^2 \left( \frac{n_1}{n_2} - 1 \right), \quad \dots\dots (9)$$

where  $A_c$  = area of inner core of fibre in  $\text{cm}^2$ , and  
 $R$  = radiance of the LED in  $\text{W}/(\text{cm}^2 \text{ sr})$ .

The power that can be launched into a fibre, assuming a radiance of  $10 \text{ W}/(\text{cm}^2 \text{ sr})$  is given in Table 2, together with the bandwidth and the coupling loss relative to the power launched into a hemisphere.

**TABLE 2**  
**Power Launched into Multimode Fibre**

Ratio of Indexes $n_1/n_2$	Optical Power into Fibre ( $\mu\text{W}$ )	Coupling Loss Relative to Power into Hemisphere (dB)	3 dB Electrical Signal Bandwidth-Distance Product assuming no mode conversion (MHz km)
1.05	200	6.4	1.8
1.01	40	13.5	8.9
1.005	20	16.4	17.7
1.001	4	23.4	88.6

To ensure adequate device reliability, it may be necessary to enclose the active parts of the LED and the photodiode in hermetically-sealed encapsulations having suitable optical windows. By the use of a suitable lens between the device and the fibre end, the coupling loss may be maintained near to the figures given in Table 2 for the LED and reasonably small for the photodiode.

### CABLES INCORPORATING OPTICAL FIBRES

Each unprotected fibre has an outside diameter of only about 0.1 mm and is, therefore, difficult to handle in the cable-making machinery without risk of surface damage due to contact with guides, pulleys or other fibres in an environment that may contain abrasive dust particles. One method of protection is to apply one or more coatings of suitable plastic or metal over the fibre, thereby increasing the overall diameter to as much as 0.3 mm, or even 1 mm. Several different techniques for fibre protection are currently under study in the UK and elsewhere.

The most important difference between glass fibres and copper or aluminium conductors for cable work is that, as they reach their tensile-strength limit, glass fibres always fail by brittle fracture without any significant plastic flow range. Young's modulus for typical glasses is in the range 70–80 GN/m<sup>2</sup>, compared with about 130 GN/m<sup>2</sup> for copper and about 70 GN/m<sup>2</sup> for aluminium. The tensile strength of the metal wires is a function of the alloy compositions used, and also of the cold-working and annealing treatments to which they have been exposed. However, the tensile strength of glass fibres can vary widely with the details of the drawing and protection methods used in their manufacture. The

maximum safe strain allowable for typical glass fibres is about 1%, compared with about 20% for copper and about 10% for aluminium-alloy conductor wires.

The density of a typical glass fibre is about  $2.5 \times 10^3 \text{ kg/m}^3$ , compared with  $8.9 \times 10^3 \text{ kg/m}^3$  for copper and about  $2.7 \times 10^3 \text{ kg/m}^3$  for aluminium. In practice, the weight of an optical-fibre cable may be dominated by that of the plastics materials needed to ensure handleability and crush resistance. The cable must be strong enough to withstand a tension equal to the weight of the cable times the coefficient of friction between the cable and the duct, with a factor to allow for bends in the duct. A suitable tensile member will need to be incorporated in the cable construction to ensure that lengths of up to 1 km or 2 km can, where possible, be pulled into duct routes to minimize the number of joints in each repeater section length of cable.

For trunk cable routes, it will be necessary to provide power-feed conductors to energize the intermediate repeaters. Due to the differing mechanical properties of conductors and optical fibres, considerable care is necessary in the design of the cable if the power-feed conductors are incorporated in the same cable. If power-feed conductors are not included, a cable having about 50 fibres could be up to 25 mm overall diameter.

In typical duct routes in built-up areas, it will be necessary to joint the cable in lengths of less than 1 km. Even assuming a very low attenuation coefficient for the fibre, the signal loss per joint must be below 0.5 dB. The attainment of this joint performance in a reproducible, reliable and economic technique in the field requires the fibre to be manufactured to close tolerances.

## SYSTEM NOISE

The noise due to the photodiode and the following amplifier is a fundamental constraint on the design of the system. Optical systems have to take account of quantum noise at the photodiode in addition to thermal noise and noise due to transistors. Quantum noise results because of the random arrival times of photons at the photodiode. The resulting electrical noise power is proportional to the detected signal current  $I_r$ , and is given by  $2qI_rR_b$  watts/hertz, where  $q$  = charge on the electron =  $1.59 \times 10^{-19}$  C, and  $R_b$  = photodiode load resistance.

When a non-avalanche photodiode is used, the noise from the following amplifier may, in general, be greater than the quantum noise, and the signal-to-noise ratio is less than that which would result from quantum noise alone. The avalanche photodiode amplifies both signal power and quantum noise by  $M^2$ , where  $M$  is the factor by which the sensitivity of the photodiode is increased by the avalanche gain. The quantum noise can be made greater than the amplifier noise, and a higher signal-to-noise ratio obtained. The avalanching process adds further current-dependent noise, which can be allowed for, approximately, by multiplying the quantum noise by  $M^x$ , where  $x$  is about 0.3.

The noise power due to the amplifier, related to its input, is given by  $4kTHf_r$ ,

where  $k$  = Boltzmann's constant =  $1.38 \times 10^{-23}$  J/K,

$T$  = ambient temperature (K),

$H$  = noise factor of amplifier as a power ratio, and

$f_r$  = 3 dB bandwidth of the equipment between the photodiode and the decision circuit.

The overall expression for the signal-to-noise power ratio,  $R_m$ , in the *mark* or ON condition is, therefore, given by

$$R_m = \frac{M^2 P_r}{2qI_r R_b f_r M^2 + 2qI_r R_b f_r M^x + 4kTHf_r} \quad (10)$$

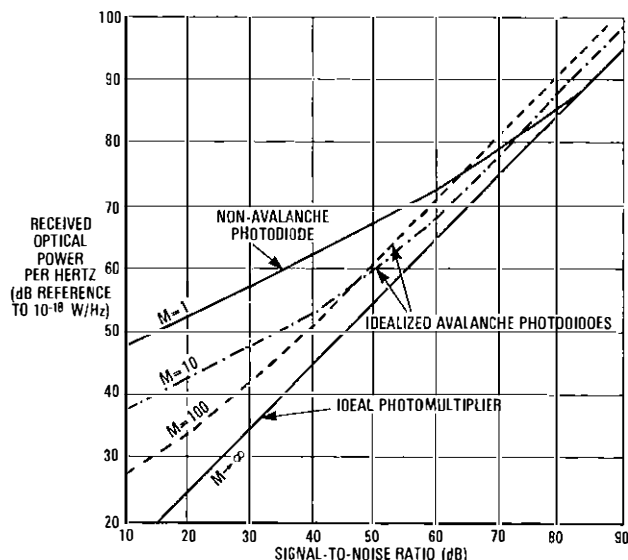

FIG. 2—Relationship between optical power received at photodiode per hertz of overall system bandwidth and signal-to-noise ratio

Substituting from equations (3) and (4) and simplifying gives

$$R_m = \frac{M^2 K_d^2 P_{or}^2 R_b}{f_r [2qK_d P_{or} R_b M^{(2+x)} + 4kTH]} \quad (10)$$

The effect of photodiode dark current has been omitted in this relationship; provided it is no more than 1 nA, the effect is to increase the required optical signal power by only about 0.4 dB at 26 dB signal-to-noise ratio for an 8 Mbit/s system. The correction is negligible at higher bit rates for 1 nA leakage current.

The quantum noise in the *space* or OFF condition is zero ignoring the effect of dark current, and the total noise is only that due to the amplifier. A conventional calculation of error rate assumes the noise to be equal in the *mark* and *space* conditions (see equation (12) below). Since this is not the case, the signal-to-noise ratio required, in practice, is somewhat less than that given by equation (10).

The relationship between the optical power required per hertz of overall system bandwidth and the signal-to-noise ratio required is given in Fig. 2. This is calculated from equation (10), and assumes that the avalanche gain factor,  $M$ , is independent of the effect of the signal current,  $I_r$ , on the bias voltage. The bandwidth of the photodiode circuit is taken to be high, at about 8 times the overall system bandwidth, and the values taken for the other parameters are given in the Appendix. The curve for a given photocurrent gain has a slope of 0.5 for low signal-to-noise ratios, where amplifier and thermal noise predominate over quantum and avalanching noise. The slope of the curve changes when the ratio of the quantum noise to amplifier noise is equal to  $2/x$ . For higher signal-to-noise ratios, the slope is equal to unity and quantum noise predominates. At very high signal-to-noise ratios, the avalanche photodiode becomes less sensitive than the non-avalanche photodiode because of the additional noise due to avalanching. For a given value of optical input signal, there is an optimum photocurrent gain.

The non-avalanche photodiode is a nearly constant-current device, and should desirably feed into a load resistor,  $R_b$ , having as high a value as possible to obtain maximum gain<sup>7</sup>; this is also approximately true for the avalanche photodiode. The higher the value of  $R_b$ , the narrower the bandwidth of the photodiode circuit. Equalization at a later stage in the system increases the bandwidth, so that there is a compro-



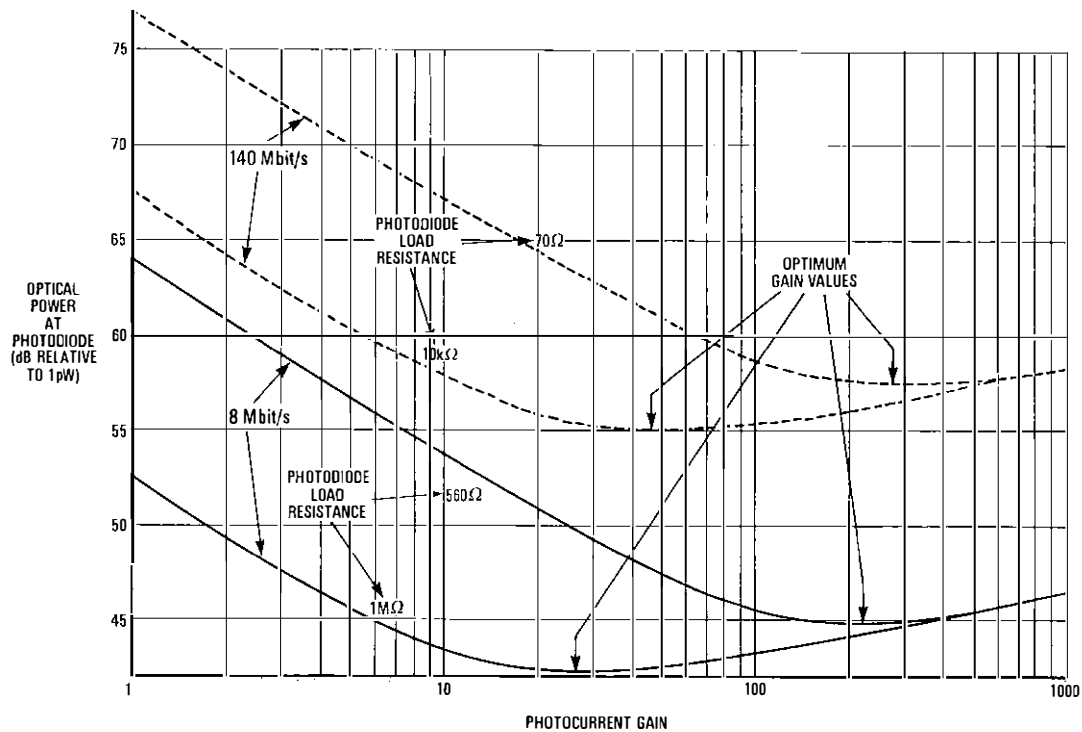

Fig. 3—Effect of photocurrent gain, bit rate and load resistance on optical power required for a signal-to noise ratio of 26 dB

mise between inter-symbol interference and increased noise, as explained later. There is a component of the amplifier noise that is not subject to bandwidth restriction by the photodiode circuit. Hence, after equalization, the mean amplitude of this component increases with frequency, and the overall increase in noise due to this effect limits the advantage obtained by increasing the load resistance.

The resultant increase in sensitivity is given in Fig. 3, for 8 Mbit/s and 140 Mbit/s systems, in terms of optical power required at the photodiode against photocurrent gain. The low-value and high-value load resistances, in each case, give ratios of photodiode circuit bandwidth to overall system bandwidth of about 8 and 0.005 respectively.

For the avalanche photodiode, the increase in sensitivity relative to the wideband case is about 2.5 dB and, in addition, the increase of load resistance has the advantageous effect of decreasing the value of the optimum gain.

For the non-avalanche photodiode ( $M = 1$ ), an increase in sensitivity of about 10 dB is obtained by the use of a high value of load resistance. However, the use of the avalanche photodiode provides a further increase of about 11 dB, and this should still prove advantageous.

### SYSTEM CALCULATIONS

Tentative designs have been made for 2, 8, 34, 140 and 565 Mbit/s systems, for the LED-multimode fibre system and the laser-monomode fibre system. It is assumed that, for both LEDs and lasers, simple ON-OFF modulation will be employed. With the normal binary input signal, there is a finite probability that long sequences with zero timing content will occur. To make the system independent of the input bit sequence it is necessary to convert the customer signals into a line code containing adequate timing information. This involves an increase in the modulation rate,  $b_m$  bauds, compared with the information rate,  $b_i$  bit/s, of about 20%.

The minimum baseband bandwidth is required. With ideal filter characteristics, it can be shown<sup>8</sup> that the 6 dB bandwidth required is  $b_m/2$ . The ideal filters are difficult to approximate in practice, and filter loss/frequency characteristics having odd symmetry about the 6 dB point may be used to reduce the inter-symbol interference at the decision circuit; a raised cosine or gaussian transmission characteristic fulfils the requirement.

In practical terms, the bandwidth of a digital system is a compromise between the greater noise power resulting from the wider bandwidth and the increase of inter-symbol interference occurring with the narrower bandwidth, the error rate being the criterion determining the optimum condition. For tentative system design work, the assumption of gaussian characteristics eases the calculation; theoretical and practical work has shown<sup>9</sup> that, when noise is introduced between 2 similar gaussian filters, optimum conditions result when the overall 3 dB bandwidth of the system,  $B$  hertz, is given by

$$B = 0.45b_m,$$

where  $b_m$  is in bit/s. In the general case of the optical-fibre system, bandwidth limitation may result from the fibre, but the bandwidth after the photodiode should be restricted to limit the noise at the decision circuit. A typical design compromise is to make the bandwidths equal. Thus, if  $f_f$  and  $f_r$  are the 3 dB bandwidths of the fibre and the receiver respectively, then

$$f_f = f_r = 0.45\sqrt{2}b_m = 0.6364b_m.$$

It is assumed that each repeater section could form part of a circuit 2500 km long, for which the error-rate objective is  $2 \times 10^{-7}$ . If a repeater section length of  $S$  kilometres can be realized, then on a proportional basis, the permissible error rate,  $p_e$ , over the section length is

$$p_e = 8S \times 10^{-11}. \quad \dots (11)$$

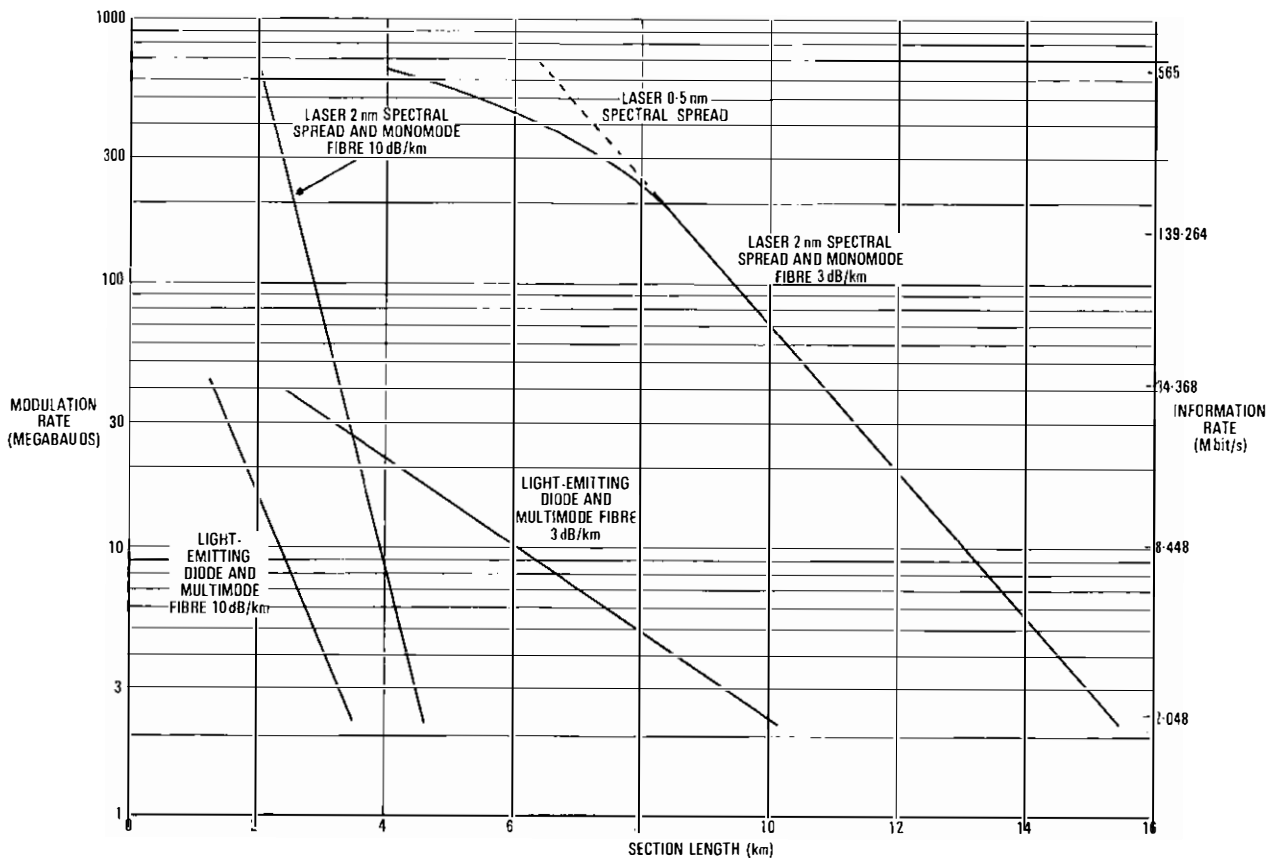

FIG. 4—Relationship between modulation rate and section length for optical-fibre systems

The signal-to-noise ratio required with a centre-decision circuit and a gaussian probability distribution of noise amplitude is given by

$$p_e = \frac{1}{2} \{1 - \text{erf} \sqrt{(R_m/8)}\} \dots \dots (12)$$

This gives a signal-to-noise ratio of 22 dB for a 2 km section length and 21.6 dB for 10 km. A margin of 4 dB is necessary to allow for inter-symbol interference and the shortcomings of the decision circuit and, thus, the signal-to-noise ratio required in practice is about 26 dB.

**System using LED and Multimode Fibre**

For the tentative design of an LED-multimode fibre system, it is convenient to make the bandwidths of the fibre and of the photodiode amplifier circuit equal, although this is not necessarily the best final allocation. The fibre bandwidth is limited by both material dispersion and multipath conditions, and the overall fibre bandwidth is estimated from the individual bandwidths assuming both characteristics to be gaussian. For a given section length, the overall fibre bandwidth and the material-dispersion bandwidth are known. The bandwidth that can be allowed for multipath conditions can, thus, be calculated. This enables the index difference of the fibre, assuming no mode conversion, to be obtained from equation (8), and also, from equation (9), the power that can be launched into the fibre. In designing systems, it is necessary to use the end-of-life parameters for the sources; for the LED, an end-of-life radiance of

10 W/(cm<sup>2</sup> sr) has been taken. The minimum optical power at the photodiode for a high value of load resistance is taken for a signal-to-noise ratio of 26 dB and for the particular system concerned. An allowance of 10 dB of optical loss is made for couplings and joints. The results can be plotted conveniently in terms of the relationship between the modulation rate and section length for fibre losses of 10 dB/km and 3 dB/km (Fig. 4).

For a 140 Mbit/s system, the section length is limited to about 0.5 km owing to the low material-dispersion bandwidth resulting from the wide spectral spread of the LED; this is a fundamental barrier and cannot be circumvented by the use of lower-loss fibre. For an 8 Mbit/s system, longer section lengths can be obtained by the use of lower-loss fibre. The practical limit is then the lowest index difference which gives reasonable guiding properties round bends normally encountered in the duct system, and which can be produced by the manufacturing process with uniformity along the length of fibre. Thus, assuming no mode conversion, a 6 km section length requires fibre with an index difference  $\left(\frac{n_1}{n_2} - 1\right)$  of 0.19% and a loss of 3 dB/km or less. The index difference is rather smaller than considered desirable, but, as already noted, a small amount of mode mixing can affect the dependence of bandwidth on length to a marked extent.

**System using Laser and Monomode Fibre**

An end-of-life figure of 1 mW is taken for the power that can be launched from the laser into monomode fibre. The bandwidth limitation of the fibre is due only to material

\* erf x = error function of x.

**TABLE 3**  
**Comparison of Metal-Conductor and Optical-Fibre Digital Transmission Systems**

System	Information Rate (Mbit/s)	Repeater Spacing (km)	Modified-Range Bit-Rate Product [km (Mbit/s) <sup>0.75</sup> ]	Number of Telephone Channels	Number of Telephone Channels per Duct Bore ( $\times 10^6$ )
Deloaded Junction Cable (paper-core-quad trunk 1040/0.63)	2.048	1.83	3	30	0.008
Coaxial Cable 1.2/4.4 mm (40-pair cable)	120	2.0	73	1700	0.07
	420	1.0	93	5760	0.23
Waveguide 50 mm diameter 32 channels 16 channels	500	20	2100	6 800†	} 0.44
	1000	20	3600	13 600†	
LED and Multimode Optical Fibre of Loss 3 dB/km	2.048	10.0	17	30	0.07*
	8.448	6.0	30	120	0.27
	34.368	1.7	34	480	1.07
Laser and Monomode Optical Fibre of Loss 3 dB/km	2.048	15	26	30	0.07
	8.448	13	64	120	0.27
	34.368	10.4	148	480	1.07
	139.264	8.5	340	1920	4.26
	565	6.5	750	7680	17.0

\* Assuming a cable containing 2220 fibres, each of diameter 0.63 mm, is used  
† Per bearer channel

dispersion. A figure of 2 nm spectral spread is used for the laser for all systems, except at 565 Mbit/s bit rate where the system design is bandwidth limited and, accordingly, a figure of 0.5 nm, which should be practicable, is used.

The bandwidth of the receiver, giving the required overall system bandwidth, is calculated assuming gaussian loss/frequency characteristics. The remainder of the calculation is the same as for the LED-multimode system above. An allowance of 10 dB of optical loss is made for couplings and joints. The results are plotted in terms of the relationship between the modulation rate and section length for fibre losses of 10 dB/km and 3 dB/km (Fig. 4). The receiver bandwidth becomes wider, the longer the section length. When the bandwidths before and after the photodiode are equal, an 11 km section length results for the 140 Mbit/s system, but the fibre loss would need to be 2.25 dB/km. For the 565 Mbit/s system, corresponding figures are 11 km and 1.7 dB/km.

As lasers can launch more power into a fibre than can LEDs, longer section lengths can be achieved with the laser at low bit rates.

### SYSTEM COMPARISONS

The results of the system calculations in terms of the repeater spacings predicted for a fibre loss of 3 dB/km are given in Table 3, together with figures for some transmission systems using metal conductors. The cost of a system consists of the cost of the repeaters plus the cost of the cable. The cost of a single repeater increases to some extent with increase of information rate,  $b_i$ , and an increase proportional to  $b_i^{0.25}$  is taken. The number of repeaters for a route is inversely proportional to the section length,  $S$ . The total cost of the repeaters for the system per Mbit/s of information rate is, thus, inversely proportional to  $Sb_i^{0.75}$  termed the *modified-range bit-rate product*. Values of this parameter are given in Table 3. The figures for the 140 Mbit/s and 565 Mbit/s optical-fibre systems show an advantage over other systems, with the exception of the waveguide system. Also shown in the table are the total number of telephone channels that could be accommodated in a single duct bore of 89 mm

diameter. Potentially, optical-fibre systems are capable of carrying large amounts of traffic. An optical-fibre system, having the same capacity as a completely-equipped waveguide system, could be realized by the use of 57 fibres, each working at 565 Mbit/s.

In making a comparison between coaxial-cable and optical-fibre systems at the same bit rate, say 140 Mbit/s, it may be assumed that the cost of the optical repeater will be the same as that of a coaxial repeater. Similar baseband equipment will be required in the 2 repeaters, but that in the coaxial-system repeater will be more complicated since a multilevel code is used. The increase in cost of this is assumed to offset the extra cost of the transmit amplifier, optical source and photodiode in the optical-fibre repeater. Hence, the ratio of the total cost of the optical repeaters for the system to the cost of the coaxial-system repeaters is inversely proportional to the ratio of their respective repeater-section lengths. From Table 3, this ratio is 1 : 4.

Optical fibre, for transmission purposes, is still in the development phase, and it is not possible to quote meaningful absolute figures of cost. Present indications are that, when production is established, the cost of cables incorporating glass fibres should be less than the cost of coaxial cables. The cost of a repeater is taken to be equal to the cost of 1 km of coaxial pair. Even if the costs of the optical-fibre cable, including the power-feed conductors, and the coaxial cable are equal, then the cost of the optical system with section lengths of 8 km would be 25% less than that of the coaxial system. The cost of optical fibres should decrease rapidly when bulk production begins, and the cost advantage to fibre systems should increase.

### CONCLUSIONS

The repeater section length of systems using lasers and monomode fibre is limited by the material dispersion of the fibre, the difficulty of launching adequate power into the fibre and the limited sensitivity of the receiver. Section lengths of about 10 km should be feasible at 140 Mbit/s and

565 Mbit/s, when low-loss fibres and reliable lasers become available.

For systems using LEDs and multimode fibre, bandwidth limitation is due to both multipath propagation and material dispersion. At bit rates as low as 8 Mbit/s, the section length obtainable will be determined by the fibre bandwidth, provided the fibre loss is about 3 dB/km. If no mode conversion occurs and the bandwidth is inversely proportional to the length of fibre, then a section length of 6 km should be possible, provided the index difference of the fibre is not so low that the guiding properties are impaired. When lasers are fully developed and reliable, low-bit-rate systems using them will become competitive with those using LEDs, because of the longer section lengths that should be possible.

Optical-fibre digital transmission systems are potentially simple and inexpensive. The reliability of LEDs, lasers and avalanche photodiodes has to be fully assessed and competitive sources of multimode and monomode, or graded-index, fibre have to be established before conditions are suitable for field trials.

Considerable advantages will result from the use of optical-fibre systems, and these warrant an increase in the development effort on the optical components for the system and on the design of systems. The cost of an optical-fibre system is likely to be considerably less than that of a comparable coaxial-cable system. It will be possible for cables containing optical fibres to be drawn into the cable ducts already provided for present telecommunication cables. Ready access will be obtained to the centres of large cities, which is an advantage compared with radio and waveguide systems. Optical-fibre cables are likely to be smaller, for a given traffic-carrying capacity, than coaxial cables or waveguides, and this could be an important consideration, bearing in mind the congestion occurring in city centres.

#### ACKNOWLEDGEMENTS

The author gratefully acknowledges the work of colleagues in the British Post Office Research Department, and the many helpful discussions that have taken place.

#### References

<sup>1</sup> ROBERTS, F. F. Optical-Fibre Telecommunication Transmission Systems. *POEEJ*, Vol. 67, p. 32, Apr. 1974.

<sup>2</sup> BEALES, K. J., MIDWINTER, J. E., NEWNS, G. R., and DAY, C. R. Materials and Fibre for Optical Transmission Systems. *POEEJ*, Vol. 67, p. 80, July 1974.

<sup>3</sup> DYOTT, R. B. The Optical Fibre as a Transmission Line. *POEEJ*, Vol. 67, p. 164, Oct. 1974.

<sup>4</sup> NEWMAN, D. H. Sources for Optical-Fibre Transmission Systems. *POEEJ*, Vol. 67, p. 208, Jan. 1975.

<sup>5</sup> MATTHEWS, M. R., and SMITH, D. R. Photodiodes for Optical-Fibre Transmission Systems. *POEEJ*, Vol. 67, p. 213, Jan. 1975.

<sup>6</sup> BOLTON, L. J., and BENNETT, G. H. Design Features and Application of the British Post Office 24-Channel Pulse-Code-Modulation System. *POEEJ*, Vol. 61, p. 95, July 1968.

<sup>7</sup> BLUMLEIN, A. D., BROWNE, C. O., DAVIS, N. E., and GREEN, E. The Marconi-E.M.I. Television System. *JIEE*, Vol. 83, p. 769, Dec. 1938.

<sup>8</sup> BENNETT, W. R., and DAVEY, J. R. Data Transmission. McGraw Hill, 1965, Chapter 5.

<sup>9</sup> DAVIES, M. C., and HICKS, J. B. Some Aspects of Digital Microwave Radio-Relay Systems. *POEEJ*, Vol. 64, p. 256, Jan. 1972.

#### APPENDIX

##### Parameters Assumed for Calculations

Figure Number	Parameter	Value
2	Ratio of bandwidth of photodiode circuit to overall system bandwidth	7.8
	Ratio of receiver bandwidth to overall system bandwidth	$\sqrt{2}$
	Photodiode zero-gain sensitivity	0.15 A/W
	Factor by which quantum noise is multiplied to allow for avalanche noise	$M^{0.3}$
	Capacitance of photodiode plus amplifier	7 pF
	Amplifier noise and photodiode dark current	Neglected
3 and 4	Capacitance of photodiode plus amplifier	2 and 8 Mbit/s 34 and 140 Mbit/s 565 Mbit/s
	Modulation rate divided by information rate	2, 8 and 34 Mbit/s 140 and 565 Mbit/s
	End-of-life radiance of LED	10 W/(cm <sup>2</sup> sr)
	End-of-life power into fibre from laser	1 mW
	Laser spectral spread	2-140 Mbit/s 565 Mbit/s
	Series noise resistance of photodiode amplifier	2 nm 0.5 nm
		400 $\Omega$

## Trunk Transit Switching

By special request, the *Journal* has produced a reprint including all the most important articles published over the years on Trunk Transit Switching. This reprint brings all the articles together and will be a most useful reference book for those interested. Supplies are limited. Please send a Postal Order or remittance for 22p per copy to:

Mr. Hunwicks  
Ground Floor Lobby  
2-12 Gresham St.  
London EC2V 7AG

If BPO staff enclose a self-addressed PO label, this will assist.

# Heating and Ventilating of Telecommunications Buildings

## Part 1—Basic Requirements

H. WILLIAMS, C.ENG., M.I.E.E.†

U.D.C. 697.1: 697.97

*This article, which will appear in 2 parts, outlines the heating and ventilating needs in telecommunications buildings. These needs are determined, to a large extent, by the comfort requirements of the occupants, as most types of telecommunications equipment will operate satisfactorily over a wider temperature range than can be tolerated by the staff. Part 1 serves as an introduction to the basic requirements of body heat balance, comfort parameters and the influence of building characteristics on comfort conditions. Part 2 will deal in rather more detail with practical systems and fuel economy.*

### INTRODUCTION

Everyone is influenced during the working day by the condition of the air in the rooms in which they work. They sense, immediately, if it is too warm or too cold; they are sensitive to draughts, and can detect if the air is stale or fresh. If all these features of the room air are to their liking, the room is accepted as being comfortable. Unfortunately, what may be comfortable for one person may be uncomfortable for another, everyone having a personal assessment of comfort which is governed by age, metabolic rate and the degree of physical effort involved in their work. Because comfort conditions are so subjective, it is necessary to produce objective standards on which to plan heating and ventilating systems.

One of the functions of the accommodation services group at regional headquarters is to plan heating and ventilating systems for telecommunications buildings, including office accommodation, telephone engineering centres, manual switchrooms and equipment rooms. The systems must be planned to fit in with the building design, and must be economical both in capital and in running costs. At the same time, the systems must meet the agreed standards of comfort. Every effort is made to produce conditions which are comfortable for most of the occupants most of the time, and these conditions will normally meet the operational requirements of the telecommunications equipment.

### BODY HEAT BALANCE

Man is a heat engine, food eaten as fuel being converted into energy in the body, a process known as *metabolism*. This energy is normally expended as mechanical work and heat. The deep-body temperature must be held at 37°C, and the temperature-regulating mechanism within the body maintains this by controlling the rate at which heat is rejected. Since the healthy body always generates more heat than it needs, this heat rejection goes on constantly. Heat is rejected in the form of

- (a) sensible heat, which can be detected by the senses or by means of a thermometer and which affects the temperature of the room; this includes radiant heat, and
- (b) latent heat, which exists in the water vapour produced

by perspiration and in the exhaled breath; this heat is given up to the room when the vapour condenses.

Average values of body heat dissipated in a room held at 20°C for different activities are shown in Table 1.

**TABLE 1**  
**Body Heat**

Activity	Heat Emission per Occupant (W)		
	Sensible and Radiant	Latent	Total
At Rest	90	25	115
Sedentary Work	100	40	140
Walking Slowly	110	50	160
Light Manual Work	130	105	235
Heavy Manual Work	190	250	440

Note: 1 W = 3.412 Btu/h

### Sensible-Heat Loss

When the air is cooler than the skin, sensible heat is removed from the body by convection. Air in contact with the skin is warmed and is replaced by cool air, this process being accelerated when the room air-flow increases. When the surrounding air is at a temperature of about 21°C, most people lose sensible heat at a rate which keeps them comfortable. Although the deep-body temperature is 37°C, the average skin-surface temperature for an adult is 27°C. If the air temperature rises to 27°C, the sensible-heat loss falls to zero, whereas above this temperature, the body gains heat from the air.

### Radiant-Heat Loss

Heat radiates directly from the body to surrounding surfaces and this process is independent of air temperature. Similarly, the body gains heat by radiation from the surrounding surfaces. There is, therefore, a simultaneous heat loss and gain by radiation, and the overall effect can be related to the *mean radiant temperature* of the room and its surroundings. This

† Liverpool Telephone Area.

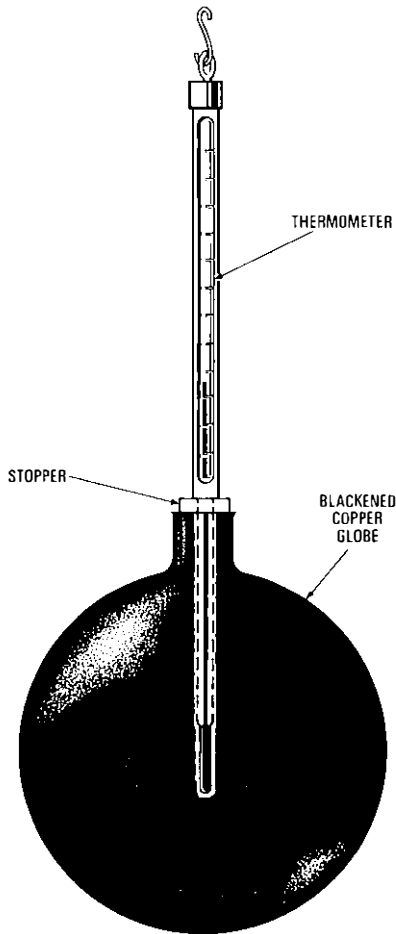

FIG. 1—Globe thermometer

mean radiant temperature is a result of the mean effect of the temperatures of all the surfaces seen by the body.

### Latent-Heat Loss

The body loses heat by the evaporation of moisture from the skin and, when the loss of heat by convection and radiation is insufficient to keep the deep-body temperature at 37°C, an automatic increase occurs in the amount of moisture which is released. The evaporation of this perspiration cools the body by latent-heat loss. The rate of cooling is increased when the air-flow increases, but a limit is imposed by the relative humidity of the air.

### COMFORT PARAMETERS

Since a person's heat loss, and hence his feeling of warmth, depends on a number of factors, it is necessary to examine these more closely and to explain how they are measured.

#### Air Temperature

This is the air temperature measured with a simple mercury-in-glass thermometer. When related to outside air, it should be taken in the shade and away from the layer of warm air that surrounds a building. It is referred to as the *dry-bulb temperature* (°C DB).

#### Mean Radiant Temperature

The mean radiant temperature is the result of the mean effect of the temperatures of all the surfaces seen by the body. A mathematical derivation of this temperature is complex, but it can be measured with fair accuracy in still air by means of a globe thermometer (Fig. 1). This consists of a mercury thermometer, the bulb of which is located at the centre of a

blackened metal globe, 150 mm in diameter. The dull black surface absorbs or emits radiant heat when the globe is suspended in a room; it also gains or loses heat from the room air. The thermometer indicates a temperature which lies between the air temperature and the mean radiant temperature. If the velocity of air movement over the globe is small, the globe temperature is close to the mean radiant temperature. More accurately, the mean radiant temperature can be calculated from the equation

$$t_r = t_g \{1 + 2 \cdot 35 \sqrt{v}\} - 2 \cdot 35 t_a \sqrt{v},$$

where  $t_r$  = mean radiant temperature (°C),  
 $t_g$  = globe temperature (°C),  
 $t_a$  = air temperature (°C), and  
 $v$  = air velocity (m/s).

### Resultant Temperature

Many attempts have been made to devise a single index combining the effects of air temperature, mean radiant temperature, relative humidity and air-flow, and allowing variations of air temperature to be compensated by one of the other factors. Of the many indexes proposed over the years, the Institution of Heating and Ventilating Engineers (IHVE) Guide 1970<sup>1</sup> adopts the resultant temperature as the index of comfort. This takes into account air temperature, radiation and air velocity, and is a close approximation to the subjective response of the human body. It is the temperature recorded by a thermometer at the centre of a blackened globe, 100 mm in diameter, and as a consequence of the smaller globe size, it is rather less sensitive to radiation than the globe thermometer. Resultant temperature,  $t_{res}$ , is derived from the equation

$$t_{res} = \frac{t_r + 3 \cdot 17 t_a \sqrt{v}}{1 + 3 \cdot 17 \sqrt{v}}.$$

When  $v = 0 \cdot 1$  m/s (an average value).

$$t_{res} = \frac{t_r + t_a}{2}.$$

### Relative Humidity

Evaporation takes place from open surfaces of water and, as a result, the atmospheric air always contains water vapour. The weight of water vapour that can be retained in 1 m<sup>3</sup> of air depends on the air temperature; warm air holds more than cool air. If warm air is cooled, it eventually reaches a temperature at which its moisture content is the maximum possible at that temperature, and it is then said to be *fully saturated*. Further cooling results in the precipitation of water in the form of a fine mist, either in the air or on the cold surfaces. The temperature at which this occurs is known as the *dew point*. Within the range of normal room temperatures, the relative humidity of the air approximates to the ratio of the weight of water vapour present in the air to that which would be present when the air is fully saturated at the same dry-bulb temperature.

If a mercury thermometer has a clean cloth fitted over the bulb, the cloth being kept moist, and this is suspended in an air stream, water evaporates from the cloth. The necessary latent heat of vaporization is then absorbed from the thermometer. As a result, the bulb is cooled and the temperature indicated on the thermometer falls to a value known as the *wet-bulb temperature* (°C WB). If the air were fully saturated, there could be no evaporation and, hence, no evaporative cooling.

One form of instrument for measuring relative humidity is the sling psychrometer, shown in Fig. 2. This consists of a wet-bulb and a dry-bulb thermometer mounted together in a frame equipped with a handle on which the frame rotates. After the cloth covering the wet bulb has been soaked in water, the instrument is held away from the body and is whirled

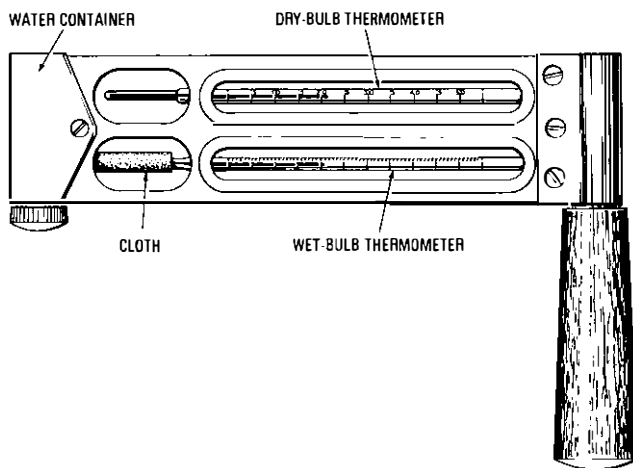

FIG. 2—Sling psychrometer

rapidly round and round for about 30 s. The whirling action produces air movement over the wet bulb at a velocity of about 3 m/s. The wet-bulb and dry-bulb temperatures are noted, in that order, on completion of the test and the relative humidity can be read from tables or graphs. It is essential that the cloth and water be kept clean; under no circumstances should the cloth be held between the fingers, as any impurities may affect the rate of evaporation and, thus, cause errors.

#### Air Movement

The rate at which body heat is carried away from the skin surface by convection and evaporation increases with increasing velocity of air movement around the body. If the rate of air movement is too high, complaints of draughts will arise, mainly as a result of excessive evaporative cooling. For sedentary work and at normal room temperature, the air movement over the body should be in the velocity range 0.1–0.2 m/s. An increase in the velocity of air movement from 0.1–0.5 m/s in an open area where light work is carried out has the same subjective effect on the occupants as a reduction in room temperature of 2°C DB. A fresh-air ventilation rate of 0.008 m<sup>3</sup>/s per person is recommended<sup>2</sup> to maintain air purity in non-operational accommodation, and this rate is easily attained by means of openable windows. In operational accommodation, however, the heat dissipated by telecommunication equipment usually makes it necessary to increase the ventilation rate by installing mechanical ventilation plant.

The velocity of air movement in rooms is too small to be measured by means of rotating-vane anemometers, and use is made of instruments which are sensitive to air movement in the velocity range 0.05–3 m/s. The 2 instruments in use are described below.

##### (a) Kata Thermometer

This is a special alcohol thermometer which is graduated at points corresponding to 38°C and 35°C. The bulb is immersed in water which is sufficiently hot to cause the alcohol column to rise above the upper mark. It is then suspended in the room air at the point of measurement, and the time taken for it to cool between the 2 graduations is measured. A calibration chart enables this cooling time to be converted into velocity of air movement.

##### (b) Hot-Wire Anemometer

This is an electrical instrument in which the velocity of air movement is determined by its cooling effect on a heated wire. It is more convenient to use than the kata thermometer,

especially if a number of readings have to be taken in a short time.

The direction of air movement is usually indicated by the path of a smoke cloud generated by chemical means.

#### Design Considerations

The IHVE Guide 1970 recommends that heat-loss calculations be based on environmental and sol-air temperatures, but these are rather theoretical and controversial issues. In the majority of heating and ventilating design calculations, where the differences between air and mean radiant temperatures are small, the resultant temperature and environmental temperature do not differ by more than 1–2°C from the dry-bulb temperature. The continued use of the dry-bulb temperature does not introduce appreciable errors into the results.<sup>3</sup> Wet-bulb temperature must be considered in the design of refrigeration cooling plant. When a temperature is not qualified, the dry-bulb value is intended. The following 2 outdoor design temperatures are important.

##### (a) Winter

Heating plant must have sufficient capacity to maintain the required internal temperatures when the outside shade temperature has fallen to the design value of the winter minimum temperature. A figure of –1°C is assumed in the UK for buildings of heavy construction.

##### (b) Summer

The condition of the outside air is important when refrigeration cooling is proposed. Not only must the plant have capacity to cool the incoming fresh air, but it must also be capable of handling the latent heat given up by the water vapour which condenses out of the air. The extreme conditions of high temperature, which arise on a few summer days only, are not considered, the plant size being based on average summer maximum conditions. For the North West of England, the IHVE recommends 25°C DB and 19°C WB related to a relative humidity of 57%.

#### REQUIREMENTS FOR COMFORT

For sedentary work, the majority of occupants will not be uncomfortably cool, nor uncomfortably warm, in winter, in rooms where the resultant temperature is in the range 19–23°C. Wide differences between air temperature and mean radiant temperature can lead to discomfort. In general, the mean radiant temperature should be within ±2°C of air temperature. A fresh atmosphere results when air temperature is slightly lower than the mean radiant temperature and the velocity of air movement is about 0.15 m/s. In summer, the resultant temperature may be increased by 1–2°C; that is, to 20–25°C. The relative humidity of the room air, within the range 40–70%, has little effect on the subjective feeling of comfort of sedentary persons.

At higher rates of activity, particularly in a warm room, perspiring is an important means of losing body heat, and reducing the relative humidity is then a factor in improving room comfort.

Where active work is undertaken, the resultant temperature should be reduced to be in the range 16–20°C. Air movement can also be increased under these conditions, the maximum rate depending on local circumstances. Where mechanical ventilation is provided, there will inevitably be a need to filter the incoming fresh air.

#### BRITISH POST OFFICE AGREED STANDARDS

British Post Office (BPO) standards of room temperatures and ventilation rates are agreed at national level between Telecommunications Headquarters and staff associations. The requirements of the Offices, Shops and Railway Premises



Act 1963 must also be observed, where appropriate. This act states that, in rooms where people are employed to work, other than for short periods, on work which does not involve severe physical effort, the room temperature shall be not less than 16°C after the first hour of a normal working day. The act also calls for "adequate" ventilation. Current BPO standards require the following conditions to be met.

(a) *Attended equipment rooms*

The minimum temperature to be maintained is 16°C and the average internal temperature rise allowed in summer is 4°C above outside shade temperature, but under certain conditions, the permitted rise in internal temperature may be less than this. Where mechanical ventilation is provided, it is designed to give a minimum of 10 air-changes/h.

(b) *Manual Switchrooms*

The minimum temperature to be maintained is 18°C and the required air-change rate is 5 air-changes/h, this normally being attained by means of openable windows. No limit is imposed on the room temperature rise in summer.

(c) *Offices*

The minimum temperature to be maintained is 18°C, but no limit is set on the internal temperature rise in summer. Adequate ventilation is normally provided by means of openable windows.

The standards also impose maximum noise levels from mechanical ventilation plant.

## BUILDING CHARACTERISTICS

Buildings protect the occupants from the worst extremes of the external climate. It is a necessary feature of building design that there should be a minimum loss of room heat in winter and a minimum gain of solar heat in summer. Heat flows out of a building by conduction through the fabric and also in the discharged ventilation air. In summer, solar radiation warms the outside surfaces of walls and roofs, and this heat is transferred into the building by conduction; direct radiation through windows warms interior surfaces which in turn warm the room air.

### Transmission Losses

If a temperature difference exists between the air on each side of a wall, heat flows through that wall, and the quantity of heat transferred in this manner depends on the materials used and type of construction. The heat transmitted per square metre of surface, per degree Celsius difference of air temperature is known as the *transmittance coefficient* or *U-value*. This is influenced by climatic conditions on external surfaces, and the IHVE Guide defines the following 3 zones of exposure for buildings in the UK:

(a) *sheltered*—up to the third floor of buildings in city centres,

(b) *normal*—most suburban and country premises, and fourth to eighth floors of buildings in city centres, and

(c) *severe*—buildings on the coast or exposed on hill sites, floors above the fifth of buildings in suburban or country districts, and floors above the ninth of buildings in city centres.

Typical U-values for various forms of construction, in localities with normal exposure, are shown in Table 2. Modern building techniques have been developed to produce structures with a low U-value at an economic cost.

When considering the heat flow through a constructional element of a building, its U-value is multiplied by the surface area and by the temperature difference of the air on each side. Separate calculations are necessary for each building element,

**TABLE 2**  
**Typical U-Values**

	Building Element	U-Value (W/(m <sup>2</sup> °C))
Walls	Brick, solid 220 mm, unplastered	2.3
	Brick, cavity, plastered	1.5
	Concrete, precast, cavity lined with expanded polystyrene plus plaster-board finish	0.8
Windows	Single glass, metal frame	5.6
	Double glazing, 20 mm air space, metal frame	3.2
Flat Roofs	Concrete 150 mm screed and plaster	1.8

Note: 1 W/(m<sup>2</sup> °C) = 0.18 Btu/(h ft<sup>2</sup> °F)

and the heat flow may be into or out of the room. Thus, heat flow, *Q*, in Watts, is given by

$$Q = UA(t_1 - t_2),$$

where *U* = transmittance coefficient (W/(m<sup>2</sup> °C)),

*A* = surface area (m<sup>2</sup>), and

(*t*<sub>1</sub> - *t*<sub>2</sub>) = temperature difference between the air temperatures on each side of the element (°C).

### Ventilation Losses

Natural and mechanical ventilation is controlled by adjustable air inlets and outlets, but most buildings have cracks and openings which allow air to flow in or out at an uncontrolled and unpredictable rate. This is known as *infiltration*. Every effort is made to reduce this fortuitous air flow, as it can account for as much as one half of the total heat loss. Natural ventilation and infiltration are influenced by wind pressure and, in tall buildings, the difference in temperature between indoor and outdoor air may give rise to an upward air movement within the lower floors. This air movement, known as the *stack effect*, is reduced by providing air locks at the entrances, or suitable barriers in the building design. Air turbulence around tall buildings gives rise to excessive natural ventilation on the windward side and insufficient ventilation on the leeward side. Fig. 3 shows this air flow for one plane only.

Infiltration occurs through

- (a) badly-fitting windows,
- (b) walls left unfinished behind panel radiators,
- (c) gaps left by poor workmanship, and
- (d) gaps which develop later owing to unequal expansion between external wall panels and window frames or beams.

Infiltration can be reduced to a value of about 1.5 air-changes/h, and the cost incurred in achieving a weather-proof building is offset by fuel savings. The storm-proofing of windows is particularly important.

Natural ventilation provides at least 4–5 air-changes/h under moderate wind conditions, whereas mechanical ventilation plant is now designed to give 10–16 air-changes/h. In the heating period, the plant recirculates the bulk of the room air and only draws in about 1–2 air-changes/h of fresh air. All fresh air drawn into the room must be heated to room temperature and this is a load on the heating system.

### Solar Heat Gain

Heat gain from the sun gives rise to ventilation problems, but the unpredictable solar gain experienced in winter is ignored when determining heating needs. When this radiant

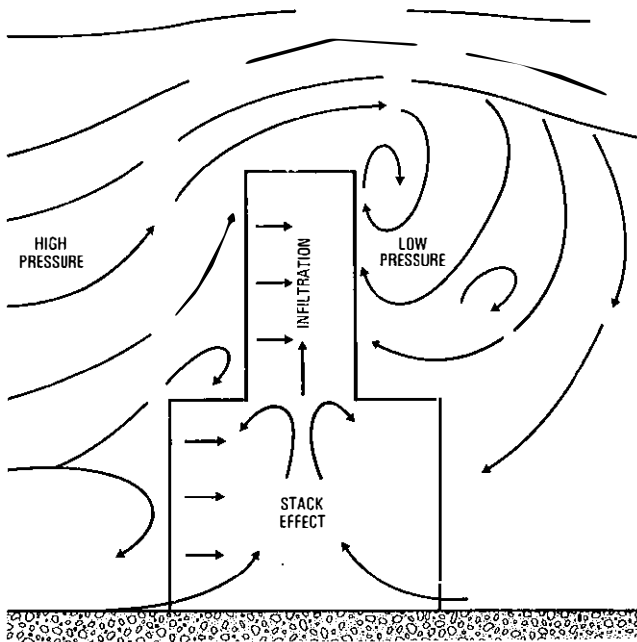

FIG. 3—Stack effect and turbulence around tall buildings

heat falls on a roof or wall, some is reflected and the remainder is absorbed into the material. The amount of heat reflected depends on the nature and colour of the surfaces. Polished metals give maximum reflection followed closely by white finished surfaces, while a dull black surface reflects very little radiation. The surface is heated to a higher temperature than the air. As a result, some of the heat is passed to the outside air to be carried away by convection, but the greater part is conducted through the material to warm the internal air. Ordinary glass passes the high-temperature radiation from the sun with negligible loss (termed *diathermancy*), but does not pass the resulting low-temperature radiation from the room surfaces (termed *athermancy*). The sun's radiant heat is, thus, trapped in the room, and this is the basic principle of a greenhouse. In fact, many rooms in modern buildings are just that.

#### Roofs

In the UK, heat from the sun falling on a flat roof can reach a value approaching  $1 \text{ kW/m}^2$  on a clear day in mid-summer, resulting in a surface temperature  $30^\circ\text{C}$  above air temperature. Roof surfaces are usually dull and dark, and little heat is reflected. If the roof is heavily constructed, there is a time lag in the flow of heat into the loft or roof space and, if it has a low  $U$ -value, the quantity of heat flowing is small. However, as the sun may shine on the roof all day, the total heat gain from this source may be high, and a low  $U$ -value is the main requirement.

#### Walls

As the sun moves across the sky, its radiant heat falls on the walls of a building with an intensity which is dependent on the season, time of day and angle of incidence. Fig. 4 gives the intensity of solar radiation on vertical walls on 21 June, and this shows that south walls receive less sun than might be expected owing to the high angle of the sun at midday. In spring and autumn, the intensity of the sun on a south wall exceeds that on east and west walls. The north wall receives diffuse radiation all the year with small peaks morning and evening in summer.

The outside surface temperature of the east wall reaches

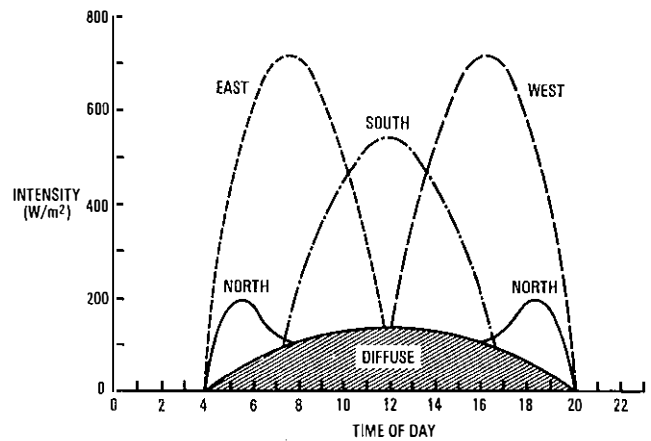

FIG. 4—Solar heat gain on a vertical face on 21 June

its peak value towards mid-morning, that for the south wall by midday and the west wall by mid-afternoon. Provided the walls have a low  $U$ -value, the amount of heat flowing into the building is small and, if the walls are heavily constructed, the flow of heat may take up to 6 h to reach the inner wall surface. This time lag has an important effect in reducing the peak heat gain. It often happens that the sun's heat will have moved off a wall before the stored heat has penetrated into the inner wall surface. Under these circumstances, the wall has an outward flow of heat to the cooler outside air, and the inward flow is, thus, reduced. The walls of most telecommunications buildings are of heavy construction and have a low  $U$ -value, so that solar heat gain through the walls is not usually a major problem.

#### Windows

By far the most important route by which solar heat enters a building is glass, as it does not attenuate or delay the flow of heat to any significant extent. Windows in offices, manual switchrooms and miscellaneous rooms should be openable to provide natural ventilation. Their provision should be the minimum necessary, and certainly not in excess of 20% of the area of any wall, the openable area being 5% of floor area. In equipment rooms, rack lighting is switched on for most of the day and mechanical ventilation is provided. Under these circumstances, large openable windows are unnecessary, and solar gain and winter heat losses will be reduced if the area of windows in these rooms is restricted to about 10% of the external wall in which they are located. All windows should be tall and narrow. Other means of reducing the effect of direct solar radiation through window glass are

- (a) external blinds, which give a reduction of 75% but create a maintenance problem,
- (b) internal blinds, giving a reduction of 35%; they darken a room, but are a reasonable compromise,
- (c) heat-absorbing glass, which gives a reduction of 30%, but darkens a room and creates a colour effect,
- (d) heat-reflecting glass, giving a reduction of 50%, but reflected glare may give rise to complaints from adjacent buildings, and
- (e) double glazing with blinds between the glass panels, giving a reduction of 70%, and natural ventilation can also be incorporated.

All these methods need to be considered for an individual building, but overall, the aim should be to reduce the provision of windows to the very minimum.

**TABLE 3**  
**Heat Dissipated by Lighting**

Equipment	Maximum Heat Dissipated (W/m <sup>2</sup> )
Telephone Repeater Station	20
Strowger Exchanges	26
TXE2 Exchanges	39
TXK1 Exchanges	50
TXK3 Exchanges	59

Note: TXE4 exchanges not yet assessed, but probably the same as for TXE2 exchanges

### The Ideal Building

The ideal building, from a heating and ventilating point of view, is not necessarily ideal for the architect, but there is a definite need to reduce the capital and running costs of the heating and ventilating services. The demands made on these services will be reduced if the aspects of building design given below are fully considered at the building planning stage.

#### Roofs

To reduce the heat flow throughout the year, the  $U$ -value should be about  $1 \text{ W}/(\text{m}^2 \text{ } ^\circ\text{C})$ . If an auto-manual switchroom is to be located on the top floor, a particularly low  $U$ -value of about  $0.5 \text{ W}/(\text{m}^2 \text{ } ^\circ\text{C})$  is desirable directly over the switchroom, or that part of the roof should be shaded to reduce solar gain.

#### Walls

These should be solidly built with a low  $U$ -value of about  $1 \text{ W}/(\text{m}^2 \text{ } ^\circ\text{C})$ . Every effort should be made to reduce infiltration to a negligible value. Cracks should be filled, and the gaps between building materials of unequal thermal expansion characteristics should be filled with a compound which will not eventually fall out. This is particularly important around window frames.

#### Windows

To reduce solar gain and infiltration, windows should be limited to the essential minimum in any wall, a provision as low as 10% of wall area being adequate for equipment rooms with mechanical ventilation. In this latter case, some windows should be openable by means of a fire key.

### OTHER HEAT GAINS

Heat gains arise from people and from the sun; they also arise from lighting, machinery and from telecommunications equipment. These gains all help to reduce fuel bills in winter, but add to the cooling load in summer.

#### Miscellaneous Gains

##### Lighting

Filament lamps dissipate their rated power as heat, whereas fluorescent lamps dissipate a further 20% of their rating as heat in the ballast circuit. A diversity factor of 0.6–0.7 should be used to allow for the fact that all lamps are seldom on at the same time. The heat generated by lighting varies for different room usage, but a maximum assumption for all rooms other than equipment rooms is  $20 \text{ W}/\text{m}^2$ . Typical maximum rates for equipment rooms are shown in Table 3.

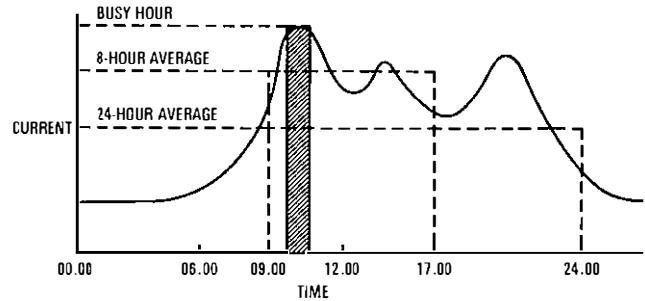

FIG. 5—Typical current load characteristics for an automatic telephone exchange

#### Electric Machines

Electric motors and plant are normally marked with their power rating, and telecommunications power plant is assumed to have an efficiency of 90%, the losses appearing as heat in the plant. The efficiency of motors varies from 70% for small motors to 90% for large motors. The losses are dissipated in the motor, but the output power may appear as heat at a point remote from the motor; for example, in the case of a lift motor, some of the output appears as mechanical energy in the lift car. Fan motors dissipate all their input power in the ventilation air and this must be allowed for when planning a ventilation scheme.

#### Equipment Heat

Modern development of telecommunication equipment has resulted in an increase in the heat dissipated per square metre of floor area in equipment rooms. Busy-hour heat dissipation can vary from  $44 \text{ W}/\text{m}^2$  for Strowger local systems to  $430 \text{ W}/\text{m}^2$  for Signalling System AC No. 9 equipment. In addition to the busy-hour peak, common-control systems have a higher standing load than Strowger equipment. Line transmission and microwave-radio equipments tend to have a fairly constant load throughout a 24 h period. For the purpose of planning accommodation services plant, it is assumed that all the power supplied to the equipment appears as heat in the equipment room. In a typical Strowger local telephone exchange, the current consumption follows a pattern similar to that shown in Fig. 5. The morning peak predominates, and an evening peak occurs due to social calls and cheap-rate trunk calls; from midnight until about 06.00 hours, very little demand is made for power other than the standing load. The maximum peak is known as the *busy-hour load* and this is observed during 1 h of the busiest period of that particular exchange. Two other current consumption values given below are also important, and are derived from the busy-hour value.

##### 8-Hour Average

This is the average value of current, and thus of power, during the period 09.00–17.00 hours. It is relevant to the planning of ventilation plant and varies typically from 0.6–0.9 of the busy-hour value.

##### Day-to-Busy-Hour Ratio

This is the ratio of total energy consumed over a 24 h day to that consumed in the busy hour. In a repeater station, with a steady power drain throughout a 24 h day, the ratio is 24 : 1. In a local Strowger exchange, the load curve is peaky and the total energy consumed over a 24 h day is reduced, so that the day-to-busy-hour ratio is less than 24 : 1; it could be as low as 8 : 1. This ratio has an influence on fuel consumption in the heating period.

The values of busy-hour power consumption, 8 h average power consumption and of day-to-busy-hour ratio are unique to each individual exchange, and it is unwise to rely on typical values. The co-operation of those involved in the planning of equipment and power plant is necessary to assess these power dissipation values. Equipment planners can help further by arranging the equipment layout so that high heat dissipating equipment is not all concentrated in one area of the floor. There is a need to equalize the heat load over the floor area, equipment which is heat sensitive being positioned remote from racks with high heat dissipation, and from windows except for those facing north. Those responsible for supervising cable runs should not overlook the need to provide access to ventilation diffusers.

## CONCLUSION

The general requirements of heating and ventilating of telecommunications buildings have been discussed in the first part of this article. Part 2 will provide basic information on heating and ventilating systems and will highlight the need for fuel economy.

## References

- <sup>1</sup> IHVE Guide, Book A. Institution of Heating and Ventilating Engineers, 1970.
- <sup>2</sup> HOPWOOD, R. W. Engineering Aspects of Staff Comfort. *POEEJ*, Vol. 59, p. 26, Apr. 1966.
- <sup>3</sup> FABER, O., and KELL, J. H. Heating and Air Conditioning of Buildings. Architectural Press, London, 1971.

## Book Reviews

*The Electric Telegraph: An Economic and Social History.*  
J. L. Kieve. David and Charles. 310 pp. 25 ill. £6.00.

Understandably, perhaps, in the prevailing circumstances, the centenary in 1970 of the establishment of the Post Office Inland Telegraph Service failed to elicit very much in the way of recognition, let alone celebration. After all, the service is now largely superseded by other Post Office facilities and the level of traffic handled has consequently fallen to a level, at the last count, of a mere 6-million or so messages per annum (the level, incidentally, at the time of nationalization).

Nevertheless, the service has exerted, in its time, an important influence on economic and social progress in this country. Admittedly, it failed to pay its way on occasions and needed a modest subsidy from the taxpayers' pockets, but its success as a public service is happily not to be judged in these terms alone. For it has always been recognized that a State-owned service has duties towards the community beyond those expected from a commercial organization, and responsibilities that may at times transcend financial considerations.

Experience had shown, during the first 24 years of telegraph development in this country, that, although a service operated on a purely commercial basis could bring increased economic prosperity to industry and commerce, and improvements in certain social institutions such as railways and the Press, conditions generally left much to be desired. Charges, for example, were based upon distance, and could thus be substantial, whilst the necessity of providing a reasonable return on shareholders' capital precluded the financing of uneconomic routes. Hence, in commercial centres where business was brisk, different companies occupied offices in adjacent premises. Some quite sizable towns, on the other hand, were virtually uncatered for. The Press, in particular, complained of delays, excessive errors in transmission and even the discriminative treatment of Press messages.

Under State control, the penetration and quality of the service quickly improved, and this, together with the introduction of low uniform rates, regardless of distance, increased traffic to some 90-million transmitted messages per annum by the turn of the century.

Underestimated and unforeseen expenses, however, coupled with rising costs and the need to maintain charges within acceptable limits, swallowed up revenue from the start, sometimes even leaving insufficient resources to meet interest charges on the compensation paid to the telegraph and railway companies, and the capital required for expansion. Although, in the early days, the service managed to hold its own in competition with the cheapness and efficiency of the penny post, traffic declined steadily as the telephone service expanded. Nowadays, Telex and Datel services meet the requirements of another age.

*The Electric Telegraph* is a detailed study of the economic, social and even political features of public telegraphs in the UK during the entire period of their existence. Except for works exclusively concerned with the techniques employed, little published information has hitherto been available on other aspects of the subject. In the present volume, technical matters are considered only in relation to the main issues,

and this could well commend the book to a less specialized circle of readers.

The work is supported by an impressive assemblage of facts and figures derived at first hand from official records, often hitherto unpublished, as well as from earlier printed sources. As the author observes, he has by no means exhausted the material available, and much remains for anyone who wishes to pursue more detailed researches.

It is a pity that the plates, which have little close relevance to the text, could not have been sacrificed in an effort to reduce the cost of a useful source of information.

D. A. J.

*Electrical Indicating Instruments.* G. F. Tagg, B.Sc., Ph.D., C.Eng., F.I.E.E., F.Inst.P., F.I.E.E.E. The Butterworth Group. 227 pp. 146 ill. £6.00.

At a time when digital meters are used so extensively, a new book on analogue instruments may seem out of place, especially if it deals with the fundamentals of instrument design. But the indicating instrument will not be extinct for a long time yet, and its design technology will still be needed many years from now. So, this work by Dr. Tagg, written after a lifetime spent in the design and manufacture of measuring instruments, is still relevant and, perhaps, even opportune. In it, he has brought together all the essential facts hitherto found only in specialist papers and the proceedings of learned societies—plus, of course, his own experience.

Chapter 1, on general principles, gives a very readable history of indicating instruments. Chapters 2, 3 and 4 are each devoted to one particular aspect of the general mechanism: suspension, damping and permanent magnets, respectively. The design criteria of such things as pivotal friction, response time and magnetic permeance, are examined in great detail. Chapters 5–9 each deal with a particular type of instrument: permanent-magnet, soft-iron, dynamometer, thermal and electrostatic instruments respectively, and cover the subject as deeply as the earlier chapters.

After all this, it is a little disappointing that the final chapter, on instrument scales—an important part of any indicating instrument—is only 3 pages long. Perhaps it leans heavily on its reference to British Standard 3693: *Recommendations for the Design of Scales and Indexes*.

An appendix gives all the data needed to enlarge the nomograms on pivot design given in Chapter 2, and a copious bibliography gives 197 references.

There are a few typographical errors in the book but, by and large, it is well produced and well printed. It is a mine of information for the instrument designer, but its text is, nonetheless, readable by the more casual user. Anyone concerned with the specification, purchase, use or repair of indicating instruments should benefit from the extra knowledge of the subject which is offered by this authoritative work.

A. K. W.  
D. B.

# Experimental Packet-Switched Service: Procedures and Protocols

## Part 2—Transmission Procedures

W. NEIL, DIP.ENG., C.ENG., M.I.E.R.E., M.I.E.E., M. J. SPOONER, B.SC., M.SC., and E. J. WILSON, B.SC.(ENG.), A.C.G.I.†

U.D.C. 621.394.4:681.32

*Part 1 of this article dealt with the packet formats used in the British Post Office Experimental Packet-Switched Service, the customers' facilities provided and the packet-switching procedures adopted. This part describes the transmission procedures used, both between synchronous customers' terminals and the packet-switching exchange (PSE), and between PSEs.*

### SYNCHRONOUS CUSTOMER-TO-PACKET-SWITCHING EXCHANGE TRANSMISSION PROCEDURES

Customers connected to the Experimental Packet-Switched Service (EPSS) by synchronous transmission links can generate and receive standard EPSS customer packets. Each customer will have the option of using either

- (a) standard transmission protocol, or
- (b) simplified transmission protocol.

The standard protocol allows a customer to obtain the maximum packet throughput from the link to the local packet-switching exchange (PSE), and also has a comprehensive range of diagnostic facilities built in to facilitate easy fault finding. The high throughput is achieved by returning, at the earliest possible time, the acknowledgement to a packet received, even if this means interrupting a packet already in transmission. The diagnostics provide information about the error performance of the transmission link, and also whether a packet has been handled or discarded by the PSE.

In comparison, the simplified protocol has fewer diagnostics, and a reduced packet throughput because an acknowledgement cannot interrupt a packet already in transmission, but must wait until the end of the packet. The actual amount of reduction in throughput cannot be quantified at present, as this is dependent on particular customers' use of the EPSS; in some applications, it may be found to be minimal.

The main advantage of the simplified protocol is that the transmission and reception of an acknowledgement is not time-critical and is, thus, simpler and cheaper to implement. This simplification is an important factor when interfacing simple low-speed (2.4 or 4.8 kbit/s) terminals to the EPSS, since the cost of the interface is a high proportion of the cost of the terminal. When the reduction in throughput is found to be unacceptable, it is expected that customers will use the standard protocol. The PSEs can operate either protocol, depending on the option chosen by the customer when first being connected to the EPSS. Changes of option can be

accommodated later by changes to customer's terminating equipment in the PSE.

Both the standard and the simplified protocols have the following basic operational characteristics.

- (a) The customer's equipment and the PSE are both byte-synchronized.
- (b) Only one packet may be transmitted before an acknowledgement to it is received.
- (c) Every packet carries error-check bytes for the detection of errors.
- (d) Error correction is by retransmission of the packet.
- (e) Packets can be simultaneously transmitted and received.

### The Standard Transmission Protocol

#### Timing and Synchronization

The customer and the PSE both obtain transmit and receive bit timing from their adjacent modems on the modem interchange circuits. However, before packets can be sent or received, the customer and the PSE have to establish byte synchronism. This is done by the transmission of bytes known as *line signals*, which are particular 8-bit codes. Subsequently, when there are no packets or acknowledgements to be transmitted, line-signal bytes are also sent to maintain the byte synchronism.

While the interface at the PSE is powered up and the adjacent modem clock is running, the transmitted-byte timing of the PSE is fixed; that is, the PSE transmits contiguous bytes. The received-byte timing is derived from the incoming line signals and, once having established byte synchronism, the PSE uses this to decode the incoming bit stream. At the customer's end of the link, the arrangements are slightly different in that the customer firstly derives the received-byte timing from the incoming line signals, and then the transmitted-byte timing is established with a fixed relationship to the received-byte timing.

#### Loop Delay

Since a customer's terminal is required to return bytes in synchronism with the received bytes from the PSE, the loop delay seen by the PSE line interfacing equipment is always a fixed number of bytes for each particular terminal, while the terminal remains synchronized to the network. Although

† Mr. Neil and Mr. Spooner are in the Telecommunications Systems Strategy Department, Telecommunications Headquarters, and Mr. Wilson is now with the Independent Broadcasting Authority.

fixed, there will be a slight variation in loop delay owing to changes in the electrical characteristic of the line. However, this is not expected to exceed  $\pm 20 \mu\text{s}$  for circuits used in the EPSS.

The loop delay is the time period from the transmission of a byte from the PSE to the time when a response byte is detected, and comprises the bothway delay through the modems plus the fixed delay at the customer, which can be up to 40 bit to enable him to respond. The loop delay,  $L$ , is defined as

$$L = P + A,$$

where  $P$  is the integer byte delay, and  $A$  is the partial byte delay.

The accurate measurement of the loop delay is an important part of the standard protocol because knowledge of this is all that enables the acknowledgement to a packet to be detected. The response delay of the PSE, which is the delay between the transmission of a byte in response to a byte received, is linked to the partial byte delay  $A$ , since it is always  $1-A$  bytes. In the current design of the line interface, the physical loop delay is always padded out to make  $A$  a half byte, to ensure that the expected variation of  $\pm 20 \mu\text{s}$  in the physical loop delay does not cause the PSE to respond at the wrong byte time.

#### Use of Line Signals

There are 3 line signals, *idle 1*, *idle 2* and *packet hold*, that are transmitted as synchronizing bytes when there are no packets or acknowledgement to be sent. The rules for transmitting these line signals are given in Table 4.

**TABLE 4**  
**Conditions for Transmission of Line Signals**

Line Signal	Conditions for Transmission
Idle 1	When line signals or acknowledgements are being received and the PSE can accept another packet
Packet Hold	When line signals or acknowledgements are being received and the PSE cannot accept another packet, or when a packet is in the process of being received
Idle 2	When the conditions for the transmission of <i>idle 1</i> or <i>packet-hold</i> signals do not apply

#### Power-Up Initiation

If the modem clock adjacent to the PSE is running, the PSE begins the power-up initiation. In this phase, the customer waits for the PSE to initiate the sequence and, hence, the PSE assumes the master role and the customer acts as slave. The timing of the events is shown in Fig. 15.

Firstly, the PSE turns the REQUEST-TO-SEND circuit on and then, after 70 ms when the READY-FOR-SENDING circuit has been turned on by the modem, the PSE continuously transmits the *idle 2* line signal. At the customer's interface, the first indication that the procedure has commenced is when the CARRIER-DETECT circuit goes from OFF to ON. Indeterminate information is then received for up to 50 ms, while the modem gains bit-synchronization. After this, the customer examines the incoming bit stream to detect 3 contiguous *idle 2* bytes, which establishes the received-byte timing. The customer then turns his REQUEST-TO-SEND circuit on and, 70 ms later when the READY-FOR-SENDING circuit has been turned on by the modem, the customer transmits *packet-hold* bytes, thus fixing the transmitted-byte timing.

Similarly, at the PSE interface, the indeterminate information received after the CARRIER-DETECT circuit is turned on is

ignored for 50 ms, and then, the incoming bit stream is examined to detect 3 contiguous *packet-hold* bytes. This fixes the received-byte timing of the PSE and, hence, the customer and PSE are in byte synchronism. Measurement of the loop delay by the PSE and the customer follows, to establish loop synchronism.

#### Loop-Delay Measurement

Since the PSE and customer must be in loop synchronism at all times, so that acknowledgements may be detected, it is necessary to measure the loop delay after any of the following instances have occurred:

- (a) powering-up of the line interface equipment,
- (b) loss of byte synchronism, and
- (c) 3 unsuccessful attempts to transmit a packet.

Loop delay measurement is carried out by sending a loop-delay-measurement packet (see Fig. 5) and then starting a count of bytes. When an acknowledgement sequence is received, the byte count is stopped and the loop delay set to the value measured. (The acknowledgement received to a loop-delay-measurement packet is identical to that for normal customers' packets). Following transmission of a loop-delay-measurement packet, the PSE transmits the *packet-hold* line signal and, if an acknowledgement is not received within 30 bytes, the loop-delay-measurement procedure is repeated.

When the loop-delay-measurement is due to 3 unsuccessful attempts to transmit a packet, the loop-delay-measurement packet is preceded with 15 bytes of the *packet-hold* line signal to prevent the customer sending a data packet while the measurement is being carried out. Loop-delay measurement may be carried out even if a customer is extending *packet-hold* line signals, thus indicating that he does not wish to receive any data packets.

#### Loss of Byte Synchronism

Since byte synchronism is fundamental to the operation of the protocol, the conditions when the interface is considered to be out of byte synchronism must be accurately defined. In the EPSS, the interface is considered to be out of byte synchronism when

- (a) the line interface and/or modem are powered up, and
- (b) 3 contiguous line signals are received which do not correspond with the previous byte timing (this only applies when a packet is not being received).

Case (b) implies that the PSE always maintains the existing received-byte timing, even if the received bit stream does not decode into line signals or a packet, until a new received-byte timing has been established.

When loss of byte synchronism has been detected, the PSE accepts the newly-derived byte timing and initiates the loop-delay-measurement procedure described above.

#### Transmission of Packets

Having established byte and loop synchronism, the customer and the PSE can transmit and receive packets. A packet may be transmitted only if the last 3 line signals received were *idle 1* or an acknowledgement. If a packet is being received at the time at which a packet is to be sent, the last 3 line signals are defined as the 3 line signals which immediately preceded the packet.

Both the customer and the PSE are allowed to send only one packet before an acknowledgement is received to this packet. This ensures that packets in the same call are always delivered and received in the correct order. Once the start of a packet has been transmitted to line, the packet is completely sent irrespective of any changes in the line signals received.

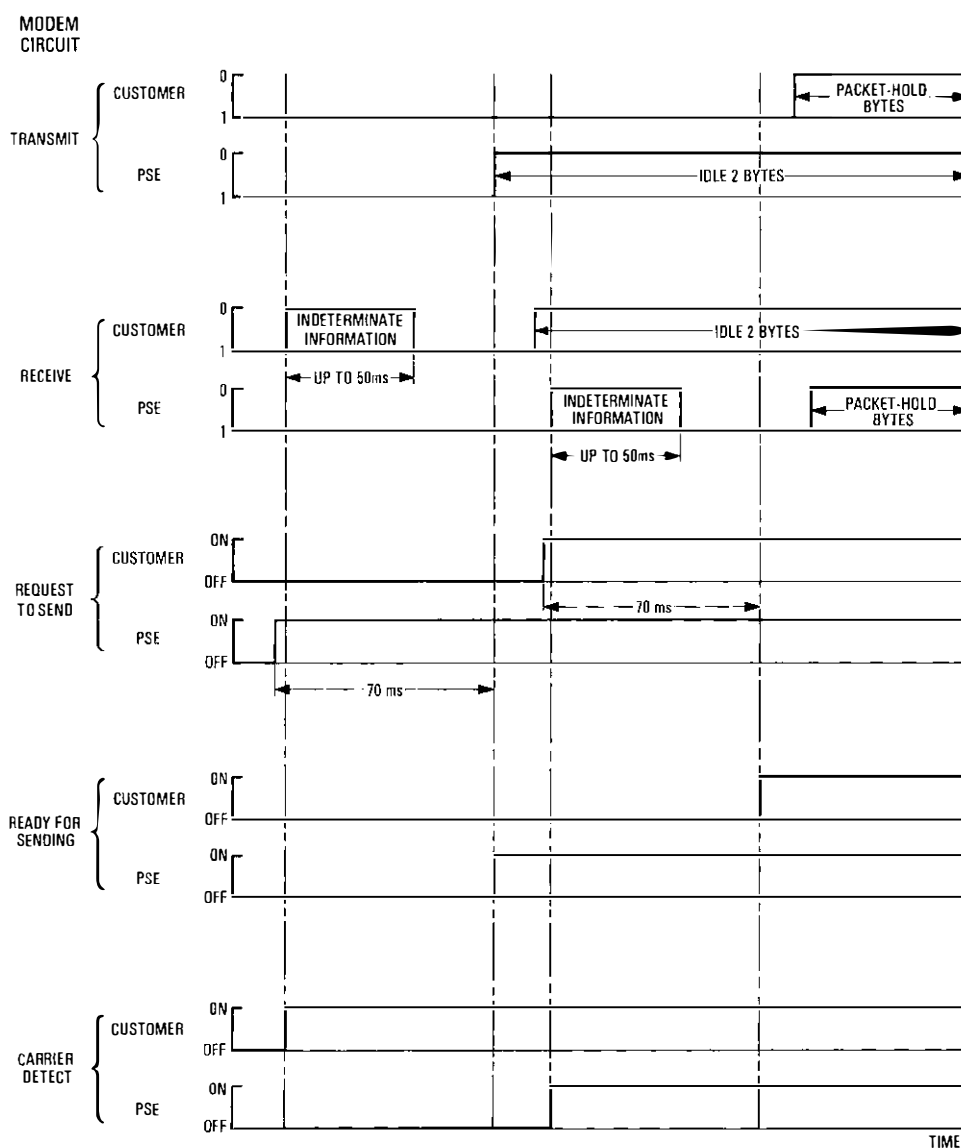

FIG. 15—Power-up initiation sequence

#### Customer-to-PSE Link Sequence Number

The customer-to-PSE link sequence number is used by the customer and the PSE for the detection of duplicate packets. These arise when a packet is received without errors and acknowledged, but the acknowledgment is corrupted and the packet is then retransmitted. The cycle of the sequence number is 1, 0, 1, 0, etc., and each packet transmitted to line carries the next sequence number in the cycle except

- (a) a retransmitted packet, which carries its original sequence number, and
- (b) after power-up and measurement of the loop delay, when the packet carries a special sequence number, 2, and then the cycle starts at 1.

#### Priority of Transmission

Sometimes, the requirements for the transmission of packets, acknowledgements and line signals may all be

satisfied and, therefore, it is necessary to have the following order of priority for transmission:

- (a) any acknowledgement,
- (b) a retransmitted packet,
- (c) a new packet, and
- (d) line signals.

#### Transmission of Acknowledgements

Each packet received is acknowledged by sending the appropriate 3-byte positive or negative acknowledgement (see Table 5). The first byte of the acknowledgement is transmitted to line after the response delay following reception of the last byte of the packet. The acknowledgement interrupts any packet in transmission, but does not pass through the cyclic redundancy checking process. After the interruption, the rest of the packet is transmitted as normal.

The acknowledgement transmitted depends upon whether

- (a) the cyclic redundancy error check is correct,



**TABLE 5**  
**Customer-to-PSE Acknowledgement**

Acknowledgement	Cyclic Redundancy Check Correct	Sequence Number in Sequence or Set To 2	Resources to Handle Packet
ACK1	Yes	Yes	Yes
ACK2	Yes	Yes	No
ACK3	Yes	No	Yes/No
NAK1 (coded as idle 1)	No	Yes/No	Yes
NAK2 (coded as packet hold)	No	Yes/No	No

(b) the customer-to-PSE sequence number is in sequence or is set to 2, and

(c) there are resources to handle the packet.

The 5 types of acknowledgement are given in Table 5.

After transmitting an ACK1 acknowledgement, the packet acknowledged is passed on to the next stage of validation. After transmitting all other acknowledgements, the packet acknowledged is discarded.

#### Detection of Acknowledgements

The PSE assumes that the acknowledgement to a packet is always the 3 bytes received  $L$  bytes after the transmission of the last byte of the packet, where  $L$  is the measured loop delay. If a packet is being received at this time, the PSE suspends the packet reception process and removes the 3 bytes from the middle of the packet. The rest of the packet is then received as normal. The 3 bytes are examined to identify which acknowledgement has been received and then the appropriate action is taken as defined in Table 6. If all 3 bytes do not decode into the same acknowledgement, they are treated as unrecognizable signals.

An ACK3 acknowledgement can be received because

(a) the customer-to-PSE sequence records at each end of the link are out of step, or

**TABLE 6**  
**Action on Receipt of an Acknowledgement**

Acknowledgement Received	Action
ACK1	The next packet for delivery to the terminal is sent without delay
ACK2	The packet is retransmitted after receipt of 3 <i>idle 1</i> bytes
ACK3	If ACK3 is received to a first attempt to transmit a packet, the PSE records a fault and retransmits the same packet with the next sequence number on without delay; if ACK3 is received to a retransmitted packet, the PSE transmits a new packet with the next sequence number on without delay
NAK1	The packet is retransmitted without delay
NAK2 or unrecognizable signals	The packet is retransmitted after the receipt of 3 <i>idle 1</i> bytes

**TABLE 7**  
**Action Taken by PSE when Discarding Packets**

Packet Discarded	Action Taken by PSE
Call-originating packet	A terminal-out-of-service NIP coded 2, 10 and marked <i>clear</i> is returned to the packet origin and the call is cleared
First-response packet or a subsequent packet marked <i>clear</i>	No NIP generated
First-response packet or a subsequent packet not marked <i>clear</i>	A terminal-out-of-service NIP coded 8, 10 is returned to the packet origin
NIP	No NIP generated

(b) the packet has already been received and the ACK1 to the first attempt was corrupted in transmission, thus resulting in a retransmission.

It is, therefore, assumed that

(a) if an ACK3 acknowledgement is received to a first attempt at transmission, the counters must be out of step and so, the packet has been discarded, and

(b) if an ACK3 acknowledgement is received to a retransmission, an ACK1 acknowledgement to a previous attempt must have been corrupted and, therefore, only the duplicate packet has been discarded.

#### Retransmission of packets

A packet is retransmitted within 30 bytes of receipt of the acknowledgement which indicates the need to retransmit the packet, provided that 3 contiguous *idle 1* bytes have been received. If the 30-byte period expires, and 3 contiguous *idle 1* bytes have not been received, the packet is retransmitted as soon as they are received.

The PSE always makes 3 attempts to deliver a packet successfully before discarding it, and where a terminal is connected to a PSE by more than one link, the PSE makes 3 attempts on each link before throwing the packet away.

#### Customer Link(s) Temporarily Out of Service

If the PSE has made 3 unsuccessful attempts to deliver a packet on a link, the link is considered as temporarily out of service and a fault statistic recorded. Repeated attempts are made to transmit to the terminal a network information packet (NIP), coded 1, 40, and indicating the time the link went out of service. This informs the customer that, as far as the exchange is concerned, the link has been out of service for the time specified.

If a customer's links are all temporarily out of service, the terminal is regarded as temporarily out of service and all packets awaiting delivery or arriving subsequently for delivery to the terminal are discarded. When packets are discarded, a fault statistic is recorded for each packet discarded, and the action taken by the PSE is detailed in Table 7.

#### The Simplified Transmission Protocol

##### Timing and Synchronization

The basic timing and synchronization procedures are identical to those for the standard protocol except that the return of an acknowledgement (which is in the form of a packet) is not time-critical. Therefore, there is no need to

measure the loop delay to establish loop synchronism. When loss of byte synchronism has been detected, the PSE uses the newly-derived byte timing to decode the incoming bit stream.

#### Use of Line Signals

The simplified protocol uses only 2 line signals, *idle 1* and *packet hold*, which are transmitted according to the conditions given in Table 8.

**TABLE 8**  
**Use of Line Signals**

Line Signal	Conditions for Transmission
Idle 1	Whenever incoming packets can be accepted (including the occasions when corrupted bytes or packets are being received)
Packet Hold	Whenever incoming packets cannot be accepted

#### Power-up Initiation

The power-up procedures are identical to the standard protocol (see Fig. 15), except that only *idle 1* bytes are transmitted as synchronizing bytes during the initiation procedure.

#### Transmission of Packets

Having established byte synchronism, the conditions for transmission of packets are the same as those for the standard protocol. The customer-to-PSE link sequence number is again used to detect duplicate packets, and the same order of priority for transmission applies. The main difference is that, although an acknowledgement packet has the highest priority, it does not interrupt a packet already being transmitted.

#### Transmission of Acknowledgements

For all packets (except acknowledgement packets) received without detected errors, the PSE transmits an acknowledgement packet as soon as possible, provided that the last 3 line signals received were *idle 1* or *packet hold*. If the acknowledgement is delayed, owing to a packet already in transmission, it is transmitted after the packet has finished. Having acknowledged a packet, the PSE checks the customer-to-PSE link sequence number. If it is the next expected in the sequence 1, 0, 1, 0, etc., or the special sequence number 2, it is passed on to the next stage of validation; if not, the packet is discarded.

#### Retransmission of Packets

If an acknowledgement is not received within 320 bytes of the transmission of the last byte of a packet, the PSE retransmits the packet as soon as possible, commencing within 30 bytes. The PSE always makes 3 attempts to deliver a packet successfully, that is, receive an acknowledgement packet, before discarding it; if the terminal is connected to a PSE by more than one link, the PSE makes 3 attempts on each link.

#### Packet Protocol for Multiple-Circuit Customers

A packet terminal may be connected to a PSE by more than one circuit, provided that it uses either the standard or the simplified protocol on all its circuits. Acknowledgements are returned on the same circuit as the packet to which they refer, but packets for transfer to the terminal are queued and transferred using whichever circuit becomes free first. Retransmission of packets for which no acknowledgement has been received always takes place on the same circuit.

If a packet forms part of a sequence of packets in a call

and hence has to be delivered in a specific order, the next packet in the sequence is not transmitted to the terminal until an acknowledgement to the previous packet in the call is received. This ensures that the terminal always receives the packets in the correct order, even if they are transmitted on different circuits.

#### Method of Error Detection

The method of error detection used in the EPSS is known as *polynomial error checking*<sup>3</sup>, or *cyclic redundancy checking*. This technique involves the addition of 16 extra bits, called *check bits* to the end of each packet transmitted to line, and the theory of the generation of the check bits is summarized below.

The packet header and data bits are considered to be the coefficients of a polynomial having the terms

$$x^{n-1} + x^{n-2} + \dots + x^{i6},$$

where  $n$  = header bits + data bits + check bits.

If this polynomial is divided, using modulo 2 arithmetic, by a generating polynomial<sup>4</sup>,

$$x^{16} + x^{12} + x^5 + 1,$$

then the check bits correspond to the coefficients of the terms from  $x^{15}$  down to  $x^0$  in the remainder polynomial formed at the completion of this division. The packet, including the check bits, corresponds to the coefficients of a polynomial which is an exact multiple (using modulo 2 arithmetic) of the generating polynomial.

At the transmitter, the header and data bits are subjected to an encoding process equivalent to division by the generating polynomial. The resulting remainder is then transmitted to line immediately after the header and data bits, commencing with the highest-order bit.

At the receiver, the incoming packet (including check bits) is subject to a decoding process equivalent to division by the generating polynomial which, in the absence of errors, results in a zero remainder. If the division results in anything other than zero, errors are indicated.

#### INTER-PSE TRANSMISSION PROCEDURES

PSEs are interconnected using 48 kbit/s synchronous transmission links. The packet transmission procedures are similar to those used for the simplified customer-to-PSE transmission protocol, except that maintaining packet order is not important, since all packets in the same call are put in order at the final exchange before being delivered to the customer. The basic principles of operation of the inter-PSE protocol can be summarized as follows.

- (a) The interfaces at each end of an inter-PSE link are byte-synchronized.
- (b) Up to 16 packets can be transmitted before the acknowledgement to the first packet is received.
- (c) Every packet carries check bits for the detection of errors.
- (d) Every packet, received without detected errors, is acknowledged.
- (e) Error correction is by retransmission.
- (f) Packets can be simultaneously received and transmitted.

#### Timing and Synchronization

The procedures for obtaining bit and byte synchronization are identical to those for the simplified customer-to-PSE protocol. One end of an inter-PSE link is nominated as the controlling end; the other end, which is the non-controlling end, returns bytes in synchronism with the received bytes.

The PSE response delay, that is, the delay between transmitting a byte in response to a byte received, is defined as

- (a) 1–*A* bytes at the controlling end, where *A* is the partial loop delay, and
- (b) 1 byte at the non-controlling end.

This ensures that byte synchronization is maintained between each end of a link.

**Transmission of Line Signals**

The 3 line signals, *idle 1*, *idle 2* and *packet hold*, are transmitted as synchronizing bytes between PSEs when there are no packets to be sent. The conditions for transmitting these line signals are given in Table 9.

**TABLE 9**  
**Use of Line Signals**

Line Signal	Conditions for Transmission
Idle 1	When line signals or packets are being received and incoming packets can be handled
Packet Hold	When line signals or packets are being received and incoming packets cannot be handled
Idle 2	When the conditions for the transmission of <i>idle 1</i> or <i>packet hold</i> do not apply

**Power-Up Initiation**

The power-up-initiation procedure is similar to that used for the standard customer-to-PSE protocol. In this case, the controlling end of the link commences the sequence of events shown in Fig. 15.

**Transmission of Packets**

Once byte synchronization has been established, a packet can be transmitted provided that the last 3 line signals received were *idle 1*. If a packet is being received when a packet is to be sent, the last 3 line signals received are defined as those which immediately preceded the packet (or packets, if packets are received contiguously).

Once the start of packet has been transmitted to line, the whole packet is sent, irrespective of any changes in the line signals being received. A PSE may only transmit up to 16 packets before the acknowledgement to the first is received. Under normal circumstances, on inter-PSE links within the UK, the acknowledgement to the first packet will be received before this limit is reached and, hence, the throughput of the link will not be restricted. The order of priority of packet transmission is the same as for customer links.

**Sequencing of Packets**

Each packet transmitted on an inter-PSE link carries a PSE-to-PSE link sequence number. This is used for identifying which packets have been acknowledged and can, therefore, be discarded; it is not used for putting packets in order or detection of duplicates. Packets are numbered 0–255 in the order they are transmitted on a link, the sequence starting at zero on powering-up the interface.

Since the packet order within a call is not maintained, and duplicates are not detected on a link-by-link basis across the network, it is necessary to put the packets in order and discard duplicates at the destination exchange before delivering the packets to a customer. An 8-bit source-PSE-to-destination-PSE sequence number is used for the purpose. This is added to a packet by the source exchange, ignored by intermediate exchanges and checked only at the destination exchange. The source-PSE-to-destination-PSE sequence number is incremented by 1 for each 0–7 cycle of the customer-

to-customer sequence number. Hence, the combined customer-to-customer and source-PSE-to-destination-PSE sequence number can be considered as one large 11-bit end-to-end sequence number, which is used for putting packets in order and discarding duplicates.

**Transmission of Acknowledgements**

An acknowledgement packet can be transmitted provided that the last 3 line signals received were *idle 1* or *packet hold*. Packets (except acknowledgement packets), received without detected errors, are acknowledged by sending an acknowledgement packet (see Fig. 6) 2–3 bytes after receiving the packet.

If the transmission of an acknowledgement packet is delayed because a packet is being transmitted and further packets are received, the delayed acknowledgement packet contains the PSE-to-PSE link sequence numbers of all the further packets correctly received, in the order in which they are received. (The length indicator indicates the number of sequence numbers in the packet.) If more than 16 packets arrive before an acknowledgement packet can be returned, any further packets are ignored and discarded; this will only occur under fault conditions.

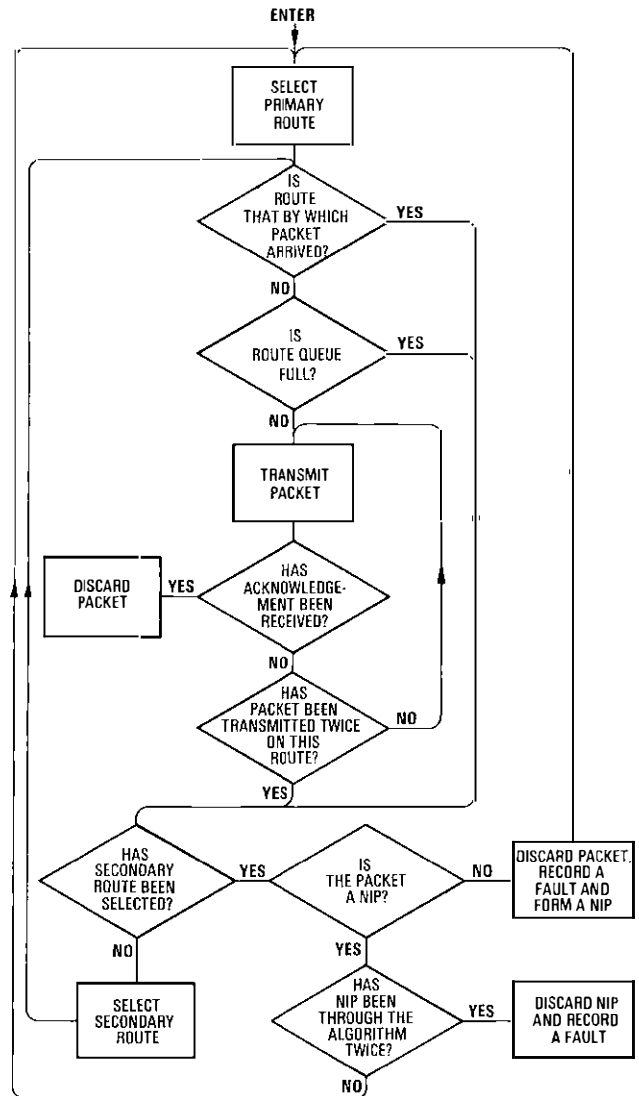

FIG. 16- Routing algorithm

## Retransmission of Packets

A packet is retransmitted if

(a) an acknowledgement to another packet, transmitted after it, is received; for example, if acknowledgements to the packets having sequence numbers 5, 6 and 8 are received, as soon as packet sequence number 8 is acknowledged, packet sequence number 7 is retransmitted with a new sequence number, or

(b) an acknowledgement to the packet has not been received within  $Y$  bytes of the transmission of the last byte of the packet.

In (b),  $Y = L + X + 297$  bytes,

where  $L$  = loop delay, which can be pre-set by the monitor and control point for each link,

$X$  = time to generate an acknowledgement (about 2 or 3 bytes), and

297 = maximum length of data packet plus maximum length of acknowledgement packet.

The retransmission of a packet commences as soon as possible, within 30 bytes of condition (a) or (b) above being satisfied, and the retransmitted packet bears the next PSE-to-PSE link sequence number. If an acknowledgement is not received for the retransmitted packet, the packet is rerouted on a secondary route, as described below.

## Routing of Packets

When a call-originating packet is received at a PSE from a local terminal, the first 2 digits of the called-address field are examined to identify the destination exchange or other packet network. To find the physical destination of the packet, the PSE refers to a translation table which holds a destination-PSE code for each of the possible 2-digit com-

binations. This translation procedure gives flexibility to the EPSS numbering scheme and customers or hypothetical exchanges can be easily moved without altering customers' numbers.

The destination-PSE code is used by the network to route a packet and, since this is carried in the main network addition of each packet, no further translations are necessary at intermediate exchanges. If the destination-PSE code in the translation table is zero, this signifies a spare exchange code and the PSE returns a NIP to the calling terminal. If the destination-PSE code is the PSE's own-exchange code, then the called terminal is local and the PSE attempts to establish a local call. Otherwise, the PSE refers to its routing table, which identifies a primary and secondary outgoing route for each of the destination-PSE codes in use, and routes the packet according to the routing algorithm shown in Fig. 16.

When a packet is received at a PSE from another PSE via the main network, the destination-PSE code is examined and, if it is not the code of that PSE, the appropriate outgoing route is obtained from the routing tables and the packet routed as normal.

## CONCLUSIONS

The transmission procedures used in the EPSS between synchronous customers and the PSE, and between PSEs, have been described in this part. The final part of this article will describe the operation of asynchronous terminals using the service.

## References

- <sup>3</sup> PETERSON, W. W., and BROWN, D. T. Cyclic Codes for Error Detection. *Proceedings IRE*, p. 228, Jan. 1961.
- <sup>4</sup> CCITT Green Book, Recommendation V41.

---

# Book Reviews

*Solution of Problems in Computer and Control Engineering.* (Vol. I.) W. B. Bishop-Miller and B. Yousefzadeh, M.I.E.C.H., C.ENG., M.I.E.R.E. Pitman Publishing. vii+200 pp. 115 ill. £2.40.

The preface to this book indicates that it is the first of 2 volumes based on the syllabi of the City and Guilds of London Institute (CGLI) examinations (Computers A, B and C, Computer Principles, and Digital Elements and Switching Principles), but that the nature of most of the subjects makes it suitable for students studying for the CGLI Electrical Technicians' Course, parts II and III, Higher National Certificate, Higher National Diploma, part II examinations of the Council of Engineering Institutions (CEI), and degree courses.

The authors are both resident lecturers in computer engineering at technical colleges and have had experience within the telecommunications industry.

Subjects covered include computer arithmetic, codes, logic fundamentals, switching principles and logic gates, basics of digital-computer programming, and analogue-computer elements and transducers.

Individual topics are explained concisely, followed by a number of worked examples based on past CEI, CGLI and college examinations. The diagrams, tables and mathematical notations are clear, and British Standard Institute definitions and symbols, together with SI units, are used throughout.

This is not a text book, but more of a reference book, and would be particularly useful for revision purposes. The solving of past papers is one of the best preparations for taking examinations, and students of the CGLI will find

this book attractive. Students of the higher academic qualifications, however, will find the book has limited depth and must await the publication of Volume 2.

M. L. J.

*J and P Transformer Book.* S. Austen Stigant, C.ENG., F.I.E.E., F.I.E.E.E., and A. C. Franklin, C.ENG., F.I.E.E. The Butterworth Group. 770 pp. 493 ill. £9.90.

This is the almost-inseparable companion to *The J and P Switchgear Book*, reviewed in the *Journal*, July 1973. The pair are regarded by many as classical reference works in their respective fields of power engineering.

The tenth edition of *The Transformer Book* follows its predecessors' approach, by building up its format from fundamental theory, and going on to define mechanical and electrical design aspects. Additionally, costing evaluation, testing and applications are covered in reasonable depth. Illustrations and diagrams are clear, well chosen and definitive.

Common operational aspects and potential fault problems are well presented, and a useful bibliography is included.

Although this edition has been up-dated to include later standards and SI units, it may be thought disappointing that little has been made of the progressive development and application of dry-type transformers, new insulants, current areas of work in the use of aluminium conductors, and the potential exploitation of electronics in protection systems.

Nevertheless, the student, practising power engineer, and specialist designer, will find appropriate sections of substantial value, and hence, will be glad to have access to this book.

C. R. N.

# A New Telegraph-Distortion Measuring Set

D. J. WILLINGTON, C.ENG., M.I.E.R.E.†

U.D.C. 621.394.4: 621.391.833.4: 621.317.7

*With the expansion of high-speed telegraph systems and the increasing difficulty of repairing early types of telegraph-distortion measuring sets, it became necessary to obtain a new tester. This article describes the purpose of these testers and compares the main features of the early and new types.*

## INTRODUCTION

Telegraph-distortion measuring sets (TDMSs) are used for the installation and maintenance of telegraph transmission and terminal equipment. Their basic functions are to generate test signals and to measure the telegraph distortion of received signals. Those in use in recent years were essentially intended as transmitters or receivers only, and all were limited in the operating rates available. With the rapid expansion of telegraph systems, operating at higher rates, it became necessary to obtain a new tester which did not have these limitations. The use of modern technology enabled many additional facilities to be incorporated into a single unit, and operation at rates extending into the medium data range was also possible.

## TELEGRAPH DISTORTION

Telegraph distortion is a measure of the time displacement, from the ideal instant, of the transition of a signal between its 2 binary states. This time displacement is expressed as a percentage of the period of a unit interval (one element, or bit).

The maximum distortion permissible in any part of a transmission link must be such that the total distortion at the receiver does not exceed the margin of the receiver. For a typical teleprinter, the received distortion must not exceed 35%, since the receiving mechanism may not respond correctly if a transition occurs displaced more than 35% of a unit interval from its ideal instant; that is, the instant at which it would have occurred in the absence of distortion.

A TDMS is used as a maintenance aid for each part of the transmission chain, including the transmitter and receiver.

## TYPES OF TEST SIGNAL AND DISTORTION MEASUREMENT

Two basic types of test signal and distortion measurement are used. These are for isochronous and start-stop transmission.

### Isochronous Transmission

#### *Isochronous Signals*

The type of signal normally used for the assessment of code-transparent transmission paths or systems, for example multi-channel voice-frequency telegraphy, is an isochronous signal.<sup>1</sup> This is any signal where all transitions are separated by an integral number of unit intervals. The signal is contin-

uously generated and has no fractional elements. It is used because it is easy to generate, and is not related to any particular code or type of machine.

Various test patterns are used, but, for telegraph purposes, the most common is the Q9S test pattern<sup>2</sup>. This is an isochronous test pattern, which consists of contiguous start-stop characters having a unit *stop*-element length. It has an equal number of *mark* and *space* elements to facilitate the detection of bias distortion, and contains the combinations of elements most likely to be subject to distortion.

#### *Isochronous Distortion*

The most convenient form of distortion measurement for assessing transmission paths is isochronous distortion.<sup>1</sup> This distortion is expressed as the sum of the distortion of the transition preceding an ideal instant by the maximum amount and the transition succeeding an ideal instant by the maximum amount.

Fig. 1 shows a distorted isochronous signal. The distortion may be determined by measurement of the difference between the actual and ideal separation of the 2 transitions having maximum distortion. Hence, no reference need be made to the ideal instants, so that a TDMS having a simple (unsynchronized) time base may be used. If a TDMS with a synchronized time base is used, the ideal instant may be derived by establishing the mean position of the received transitions. The isochronous distortion can then be expressed as the sum of the peak-early and peak-late readings.

## Start-Stop Transmission

#### *Start-Stop Signals*

These signals are generated by terminal equipment, such as teleprinters, which are designed to operate on the start-stop system. Each character is represented by a *start* element, a fixed number of code elements (5 for Telex, which uses International Telegraph Alphabet No. 2) and a *stop* element. The *start* element, which in the UK is normally of positive (*space*) polarity, prepares the receiving mechanism for the receipt of the code elements. The *stop* element is normally of negative (*mark*) polarity, and it allows the receiving mechanism to come to rest in preparation for the next character. The receiver need not employ any means of automatic synchronism, since the speed need remain constant only over the period of each character.

#### *Start-Stop Distortion*

Start-stop distortion<sup>1</sup> can be measured only when receiving start-stop signals of a known character length. It is used

† Telecommunications Development Department, Telecommunications Headquarters.

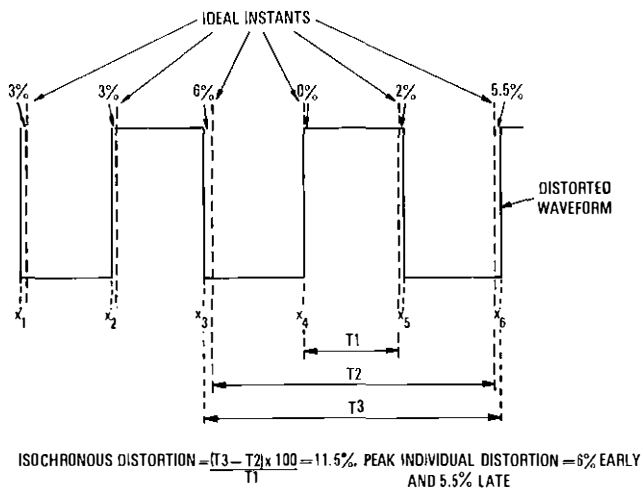

FIG. 1—Distorted isochronous signal

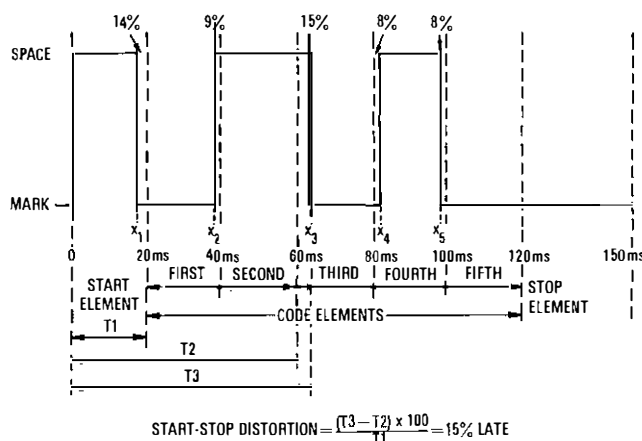

FIG. 2—Distorted start-stop character (5-unit code, 50 baud)

primarily for testing equipment designed exclusively for start-stop working. The ideal position of each code-element transition is defined by reference to its displacement from the beginning of the *start* element (the reference instant). Hence, for a distortionless character, each transition is displaced from the reference instant by an integral number of the unit intervals. The distortion normally quoted is the maximum transition displacement, either early or late from this ideal. Fig. 2 shows a distorted start-stop character.

This type of measurement involves the use of a TDMS having a stable time base triggered by the *start* element of each received character.

## HISTORY

### Tester TG 958

Known as the *Jolley Tester*,<sup>3,4</sup> the Tester TG 958 was developed by E. H. Jolley of the British Post Office (BPO) Research Department, and was an electromechanical device,

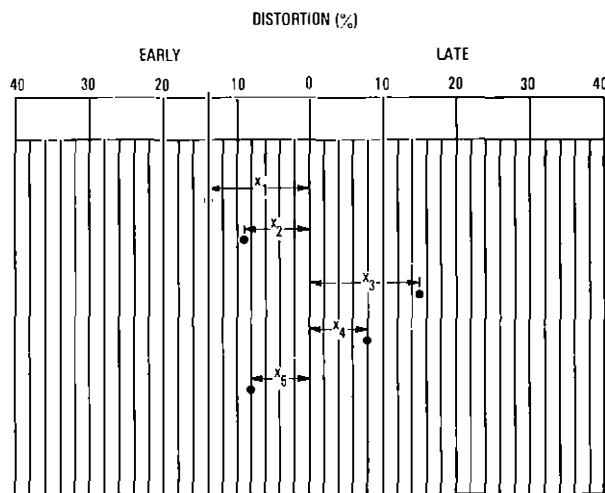

FIG. 3—Display of start-stop distortion on Tester TG 1157

used from the early 1930s. The transmitter used a 7-segment distributor plate and a rotating brush. A sliding segment was used to shorten or lengthen the *start* element to superimpose distortion for margin testing of teleprinters etc. The receiver used a rotating disc having a narrow radial slot cut into it, behind which was mounted a neon tube, this being supplied with current pulses via slip rings. The disc and neon made one complete revolution in the time for one character. Each signal transition caused a pulse of current to pass through the neon tube, so that the time distortion of the transitions, in terms of percentage of a unit interval, could be determined by noting the position of the flashes in relation to a graduated scale surrounding the disc.

### TDMSs 74101 and 74511

These TDMSs each consisted of an isochronous transmitter and receiver. The display on earlier receivers was similar to that of the TDMS type 6, except that each transition was represented by a radial line instead of a dot on the circular display of a cathode-ray tube. Later receivers featured 25 marker dots, spaced at 2% intervals on a circular display, with every fifth dot brightened to show the 10% intervals. Transitions were represented by radial flashes displaced from the circular trace. These flashes were outside the ring of marker dots for negative-going transitions and inside for positive-going transitions.

### Tester TG 1157

In 1950, the Tester TG 1157<sup>5</sup> was developed by the BPO Research Department. This was a start-stop, receive-only device, limited to 50 bauds. Each transition was represented by a dot on a cathode-ray tube, the display having been initiated by an incoming *start* element. The 6 possible transition positions in the 5-unit code were represented by 6 horizontal scans. These 6 scans, each taking 20 ms, were arranged one above the other. For an undistorted signal, the dots appeared in a vertical line at the centre of the screen. Early transitions were indicated by dots to the left of the centre line and late transitions by dots to the right of the centre line. The distortion was measured using an engraved graticule in front of the screen. The display shown in Fig. 3 is that for the signal of Fig. 2.

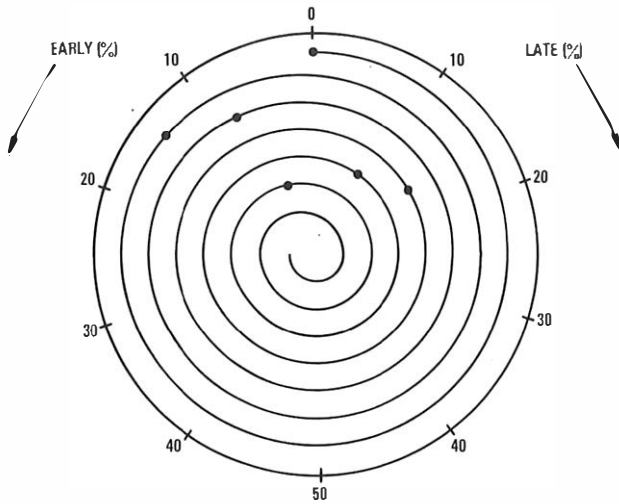

FIG. 4—Display of start-stop distortion on TDMS type 6

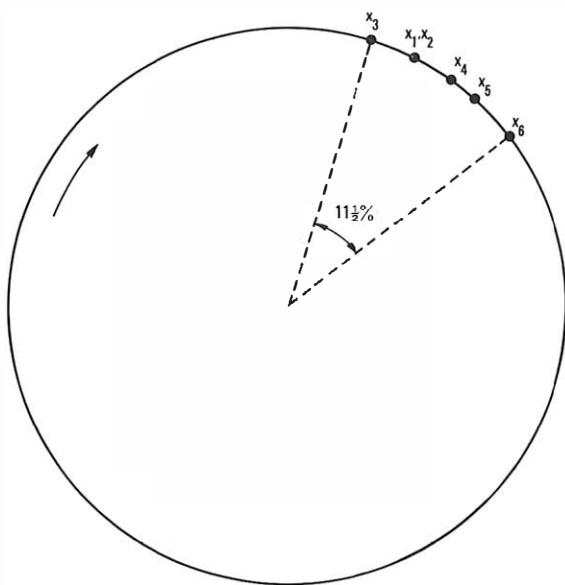

FIG. 5—Display of isochronous distortion on TDMS type 6

### TDMS Types 5 and 6

Another type of TDMS in current use consists of 2 separate instruments. The TDMS type 5, in its various forms, is primarily a transmitter. It includes a means of monitoring the transmitted *start*-element distortion, which can also be used for measuring the isochronous distortion of incoming signals. The TDMS type 6 may be used for measuring start-stop or isochronous distortion. The type of display used on the TDMS type 6 is shown in Fig. 4 for start-stop distortion and Fig. 5 for isochronous distortion.

For the measurement of isochronous distortion, each transition is arranged to form a dot on a circular trace on a cathode-ray tube. The time-base rate is manually adjusted so that the time for each revolution of the trace is as close as

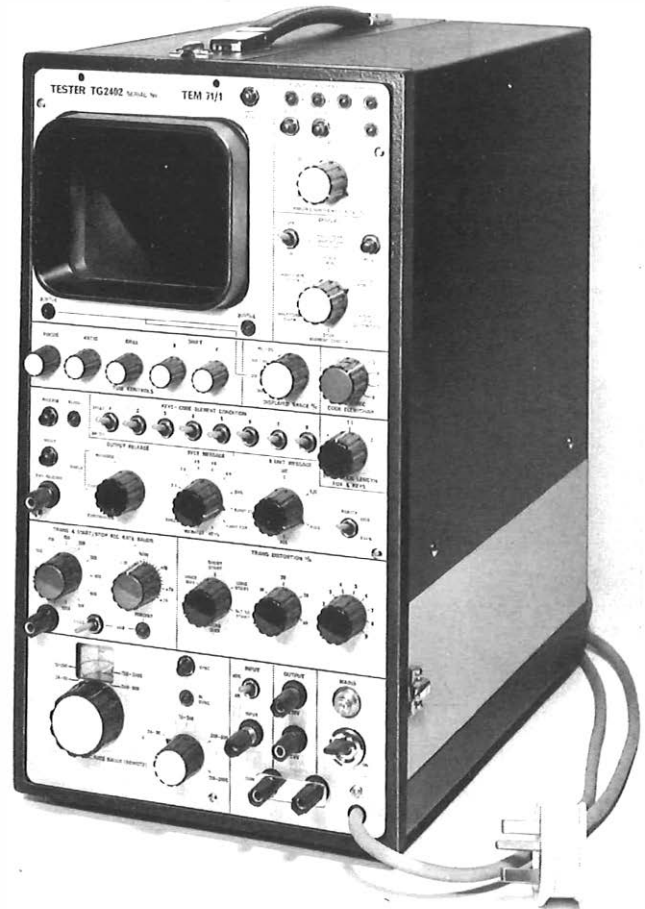

FIG. 6—Tester TG 2402

possible to the mean element period of the received signal. In practice, this is effected by varying the rate of revolution until the display as a whole remains stationary. If the signal is undistorted, the dots are coincident at an arbitrary point on the circular trace. The display shown in Fig. 5 corresponds to the signal shown in Fig. 1.

For the measurement of start-stop distortion, the display takes the form of dots appearing on the convolutions of a spiral time base. The time for each of the convolutions of the spiral is equal to the unit interval of the incoming signal. The number of convolutions corresponds to the number of possible transition instants in the received signal. If the signal is undistorted, the transition indications appear in a vertical line. Fig. 4 shows the display for the signal shown in Fig. 2.

### TESTER TG 2402

The new type of TDMS is known as the Tester TG 2402, and was developed to a BPO specification following competitive tender. It is a portable, mains-operated tester, incorporating receive and transmit functions complete with internal signalling supplies. The range of facilities provided may be seen by reference to Fig. 6.

A basic requirement of the new tester was a high measurement accuracy, without sacrificing the versatility provided by earlier types. A cathode-ray-tube display, similar to that provided by the Tester TG 1157, provides the versatility, and calibrate dots are included in the display, at 1% intervals, to

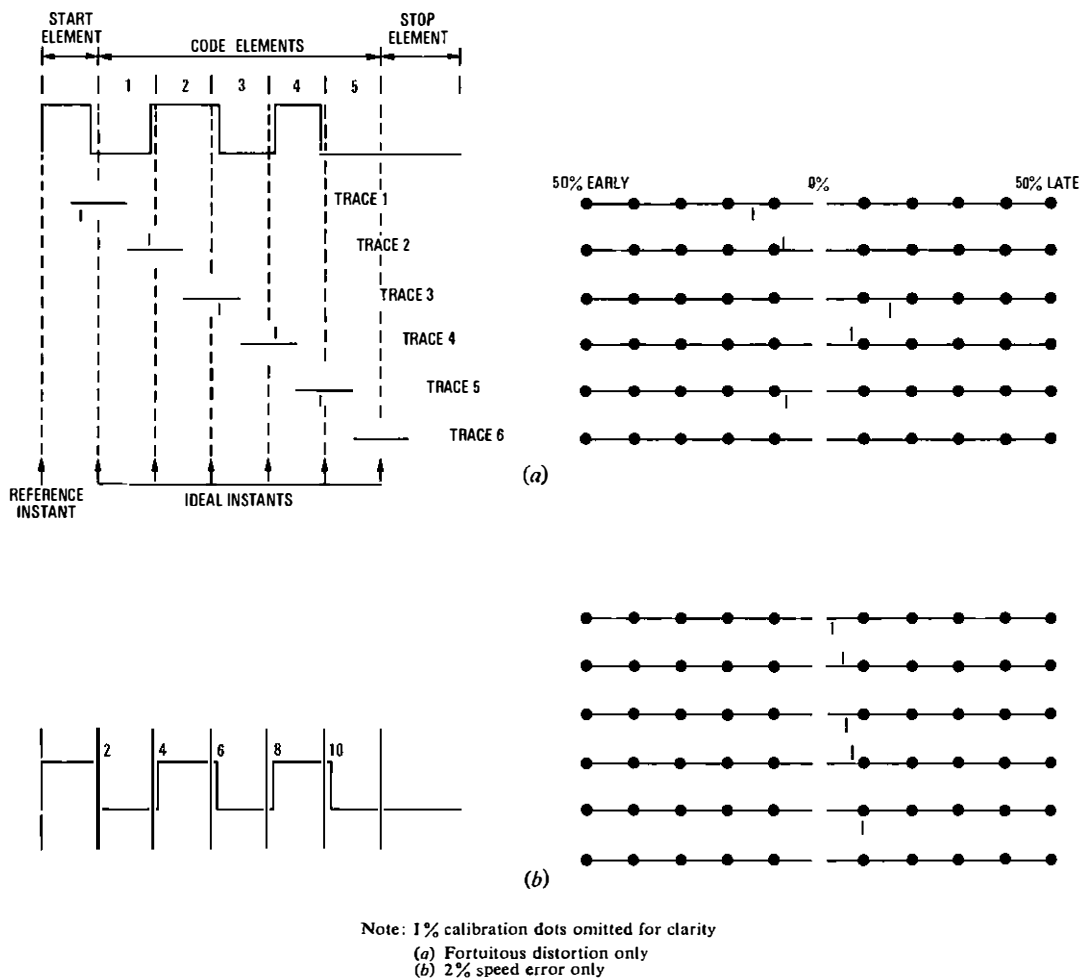

FIG. 7—Display of start-stop distortion on Tester TG 2402

give the required reading accuracy. The use of a cathode-ray tube has the additional advantage of enabling a waveform-display facility to be included.

To further ease reading of the distortion display, a *hold-peak* facility is provided, this being made possible by the use of digital circuitry. The peak isochronous or start-stop distortion can thus be easily determined to a high accuracy, without continuous close observation. For isochronous measurements, a synchronizer is included to ensure a stationary display.

A further requirement of the tester was that it should be fully self-contained. This means that only one instrument is required for transmit and receive functions. In addition, signalling supplies of  $\pm 6$  V and  $\pm 80$  V for the test messages are provided internally. The QUICK-BROWN-FOX and Q9S test messages are provided by a single integrated circuit, and the output relay is also solid state. All mechanical adjustments are, thus, eliminated. The basic send and receive rates are derived from a crystal oscillator so that no external source is required for calibration. The tester is also designed to work over a wide range of mains voltages, without any readjustment.

### Construction

The tester measures 221 mm wide, 406 mm high and 370 mm deep, its weight being 16.5 kg. Extensive use is made of silicon integrated circuits and a metal-oxide-semiconductor read-only memory store is used for the test messages. Light-emitting diodes are used for various display purposes. The

circuitry is mounted on 3 printed-circuit boards, plugged into a mother board, which, in turn, is plugged into a connector on the front panel. The major power-supply components are carried on the left-side extrusion, the rear panel forms a heat sink for the power transistors and the e.h.t. circuit is contained in a separate box mounted on the rear panel.

The controls are grouped according to function and the knob inserts are colour-coded; black for transmit functions, grey for receive functions and green for controls covering both transmit and receive functions.

### Transmitter

The basic pattern required is selected on the TEST-MESSAGE switch. Any transmit rate in the range 37–1512 bauds may be selected. A clock, running at 100 times the element rate, drives a counter at 1% intervals during each element to enable distortion to be applied to the test messages in 1% increments for teleprinter-margin testing etc. Distortion is applied by shortening or lengthening the count to vary the element length by the required amount. The test messages may be released continuously, or in increments of one character, or of one complete test message. The QUICK-BROWN-FOX test message may be transmitted using International Alphabet Nos. 2 or 5 (5-unit or 8-unit respectively). The 8-unit QUICK-BROWN-FOX message may be generated with odd or even parity, and consists of 3 lines (upper case, lower case, and figures and symbols) which may be transmitted individually or in sequence. Each line of the 5-unit and 8-unit QUICK-



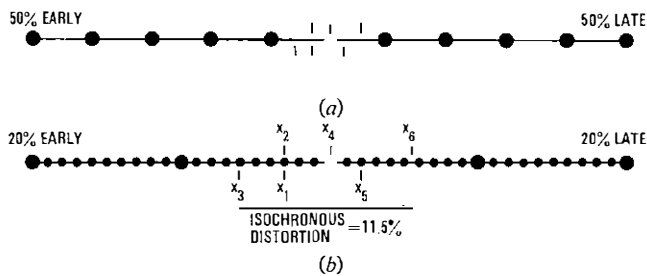

(a) Displayed range 50% early to 50% late  
(b) Displayed range 20% early to 20% late

FIG. 8—Display of isochronous distortion on Tester TG 2402

BROWN-FOX messages is preceded by carriage-return and line-feed characters and a 200 ms period of mark polarity. The 200 ms mark period allows time for a teleprinter carriage to return, this being necessary with machines working at high signalling rates since the period of the carriage-return and line-feed characters may not be sufficient. On the QUICK-BROWN-FOX messages, and on characters generated by the keys function, the stop element length may be set to 1, 1.5 or 2 elements.

### Receiver

The distortion display used on the new tester is illustrated in Figs. 7 and 8. With an isochronous or start-stop distortion display selected, a complete row of calibrate dots is displayed for each possible code-element transition in the received signal. Each row commences half an element before the ideal transition instant and ends half an element after the ideal instant. Hence, the extreme left of the display represents the 50% early point, and the extreme right represents the 50% late point. The ideal instant is, therefore, at the centre of the row of calibrate dots. This display is generated by a horizontal deflexion signal which increments the display in 0.5% steps, and a blanking pulse at every alternate step results in a calibrate dot at every 1% step. Every tenth dot is brightened to indicate the 10% intervals, and the dot at the ideal instant is blanked out to indicate the 0% point.

For start-stop distortion, the time base is triggered by the start element of each character, and is then allowed to run at an accurately controlled rate for the period of one character. This results in the display of a row of calibrate dots for each possible code element transition in each character. These rows may be displayed superimposed or separately. For the detection of characteristic distortion, or transmit-rate error, they are displayed separately, one above the other, as shown in Fig. 7. If the peak distortion only is required, the rows may be superimposed to give a single-line display.

When an incoming transition is detected, a pulse is generated to coincide with the next 0.5% step of the horizontal time base. This pulse is used to give a dot just above or below the row of calibrate dots, so that the distortion of the transition is indicated by the adjacent calibrate dot (or 0.5% interval). Thus, early transitions are indicated by a dot to the left of the 0% point, and late transitions by a dot to the right. These dots appear above or below the row of calibrate dots according to the polarity of the transition.

The time taken to write the display for each complete character is determined by the setting of the start-stop RECEIVE-RATE control. Any difference between this setting and the rate of the incoming signals results in a cumulative increase in the distortion of the transitions in each individual character. When the rows of calibrate dots for each possible

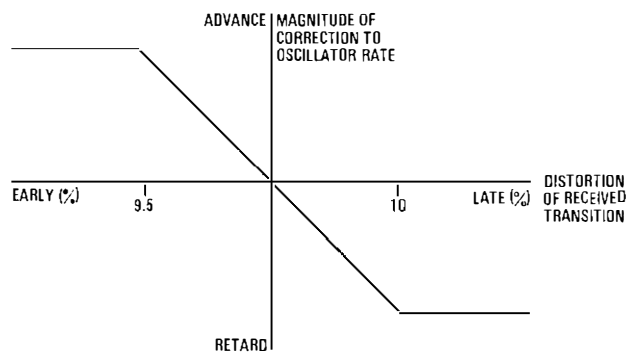

FIG. 9—Tester TG 2402 synchronizer characteristics

transition in each character are displayed separately, the cumulative increase in distortion results in the transition dots forming a diagonal display (see Fig. 7(b)). For most purposes, any such error is eliminated by adjustment of the variable RECEIVE-RATE control so that a vertical display of transition dots appears about the 0% point. When testing equipment back-to-back or looped, the same tester is used for transmitting and receiving and no such adjustment is necessary, since the same oscillator is used for the transmitter and the start-stop receiver.

When measuring isochronous distortion, a single row of calibrate dots is displayed continuously, as shown in Fig. 8. The occurrence of an incoming transition is indicated by a dot above or below the line of calibrate dots, as for start-stop working. The isochronous distortion is then measured as the total displacement between the outermost transition dots on the display. However, since the display is not triggered by the incoming data as it is when receiving start-stop signals, the position of the transition dots does not bear a simple relationship to the centre of the display. Also, any slight difference between the time-base and received-signal rates would result in the transition dots drifting across the display. These problems are overcome by locking the phase and frequency of the time base, and hence of the calibration-dot display, to the incoming data. A synchronizer, similar to that used in Datel testers,<sup>6</sup> is used. The isochronous RECEIVE-RATE control is first adjusted for a nearly stationary display, to bring the time-base oscillator rate within the pull-in range of the synchronizer. Thereafter, automatic corrections are superimposed upon the manual setting to give a stationary display about the centre of the screen. Corrections are then applied in proportion to the average distortion received over the range 9.5% early to 10% late, as shown in Fig. 9. The range of proportional correction is limited to prevent isolated transitions, that occur very early or very late, introducing over-correction. Outside this range, a constant correction is applied. The small errors which this system introduces may be eliminated where back-to-back or local tests are being made. This is done in the *isochronous-local* mode, by locking the receiver time base to the transmitter.

A hold-peak facility is provided on the single-line, start-stop display and, optionally, on the isochronous display. This gives a continuous indication of the peak early and late reading (until reset), in addition to the display for each received transition. The normal mode of operation for start-stop or isochronous distortion measurements is with the hold-peak facility switched on. Where possible, the single-line display is expanded to cover the range 20% early to 20% late. The peak distortion can then be easily determined to a high accuracy, without continuous close observation. If a transition occurs with a distortion outside the displayed range, a warning-light indication is given, so that the displayed range may be adjusted accordingly.

Additional start-stop receiver facilities include the measurement of stop-element length, the display of waveforms and

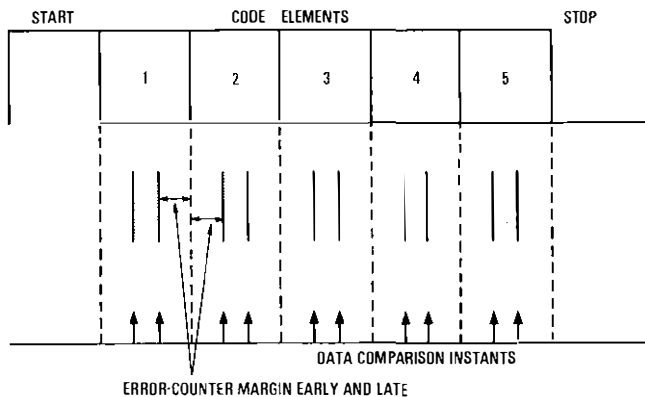

Note: received signal must be of correct polarity at the instants bounding the shaded period to be registered correctly

FIG. 10—Error-counter margin on Tester TG 2402

the detection of character errors. The display used for the measurement of *stop*-element length is similar to that of Fig. 7, except that it commences where the normal display finishes and ends at the beginning of the next *start* element. The waveform display is triggered by each *start* element, so that a complete character may be displayed. With the waveform display expanded in the horizontal direction, the 10% calibrate dots are superimposed to facilitate such measurements as relay flight time. Character errors may be detected when receiving the 5-unit QUICK-BROWN-FOX test message. This can be used to detect inverted elements and characters having distortion in excess of a pre-set margin, as shown in Fig. 10. This facility, together with the hold-peak distortion facility, permits long-term unattended monitoring.

In addition to the various receiver displays, an interface is provided for a data logger. Outputs include character error pulses and timing information associated with the distortion measurement. This facility may be used to give a permanent record of measurements made with the tester and to give information on the distribution of the distortion on a circuit.

## CONCLUSIONS

A new TDMS has been developed that incorporates the essential transmit and receive functions of the earlier testers with greater measurement accuracy and less operator fatigue. Several new features have been introduced, including a hold-peak distortion facility on the cathode-ray-tube display, and automatic synchronization when making isochronous distortion measurements. Extensive use has been made of silicon integrated circuits and a metal-oxide-semiconductor read-only memory store is used to provide the test messages.

## ACKNOWLEDGEMENT

The Tester TG 2402 was developed to a BPO specification by Trend Communications Ltd.

## References

- <sup>1</sup> CCITT Green Book, Vol. VII, List of definitions of essential technical terms.
- <sup>2</sup> CCITT Recommendation R51.
- <sup>3</sup> JOLLEY, E. H. Determining the Transmission Efficiency of Telegraph Circuits. *POEEJ*, Vol. 26, p. 3, Apr. 1933.
- <sup>4</sup> FREEBODY, J. W. *Telegraphy*, New Era, 1958.
- <sup>5</sup> WHEELER, L. K., and TISSINGTON, R. S. An Electronic Distortion Measuring Set for Start-Stop Telegraph Signals. *POEEJ*, Vol. 43, p. 18, Apr. 1950.
- <sup>6</sup> QUINNEY, R. E. Recent Developments in Datel Testers. *POEEJ*, Vol. 64, p. 27, Apr. 1971.

## Book Review

*Engineering Principles for Part I Electrical and Telecommunication Technicians*. J. O. Paddock, M.I.T.E., and R. A. W. Galvin, B.Sc. English Universities Press. xiii+354 pp. 261 ill. £2.95 (boards), £1.85 (paperback).

So many text books have been written on the City and Guilds of London Institute (CGLI) Part I Telecommunication Technicians' Principles Course syllabus, that there cannot now be much possibility of any originality of presentation. Each lecturer produces his own teaching notes and each has his own style of presentation to a class. When he writes a book from his lectures, the resulting textbook is a reflection of this style. The environment of the college, the type and quality of student and, in all probability, the prevailing local electrical trade requirements, all contribute to some extent to the result.

This book is a straightforward presentation of the CGLI Part I Telecommunication Technicians' Course syllabus. The authors have taken care not to stray beyond the syllabus of the Part I Course. They have, in fact, included some items from the previous year's studies; for example, the chapter on electrochemical effects includes an elementary account of primary and secondary cells and a statement of Faraday's laws of electrolysis.

The 2 chapters on elementary mechanics are welcome. Telecommunication technicians often omit this part of the syllabus in their study—a serious omission which they may live to regret. The techniques of using simple vector diagrams of forces, Young's modulus, work and energy, and the mechanical efficiency of electrical machines, should all be as

familiar to telecommunication technicians as an impedance,  $a + jb$ .

There is a healthy chapter, labelled "Electronics I", on semiconductors and transistors, followed by a somewhat skeletal account of thermionic triode valves and their load lines. Many telecommunication technicians still have to spend time maintaining thermionic-valve circuits, especially on overseas locations, so it is important that teaching of thermionic-valve theory is not allowed to decline. The first duty of technical colleges is to train technicians who are able to support industry, and thermionic-valve equipment is not likely to disappear for many years ahead.

The chapter labelled "Electronics 2" is a curious mixture of applications of semiconductors, thermionic triodes, and telephone instruments. The telephone receiver and microphone are the most important elements in a telephone system and the CGLI recognizes the fact. This book hardly does them justice, even at Part I Telecommunication Technicians' Course standards. The balanced-armature telephone receiver is not even mentioned, which is a pity because some colleges find this item difficult to teach adequately and might welcome help.

The publishers have done a good job. The book is well presented on good-quality paper with clear print. Diagrams are clear and concise. Questions are listed at the end of each chapter, preceded by a few worked examples. These all draw heavily from CGLI sources, and there is evidence of the type of presentation used in the model answers published by the *Post Office Electrical Engineers' Journal*.

C. F. F.

# Label-Printing Machines in the British Post Office Factories Division

W. L. GOLDIE, B.SC., C.ENG., M.I.E.E., S. LIFFORD, C.ENG., M.I.MECH.E., and A. O. M. NETHERCOT†

U.D.C. 621.798.6:681.6: 655.32

*The British Post Office (BPO) Factories Division design of hot-press printing machine has been developed, and commercially-designed machines jugged and guarded, to facilitate the printing of the 30-million rigid and self-adhesive vinyl labels required by the BPO Businesses each year. The reasons for the designs are outlined and details given of the printing production processes used at the Division's label-printing centre at Cwmcaru in South Wales.*

## INTRODUCTION

The British Post Office (BPO) uses millions of labels each year for labelling equipment in the Telecommunication, Postal and Giro businesses. There is also a large demand for information and signposting-type labels, many of which are required to meet an aesthetic standard in keeping with the new corporate image. Most of these are produced by the label-printing centre in the BPO Factory at Cwmcaru in South Wales. The centre is capable of producing rigid-plastic and metal labels, and flexible self-adhesive vinyl labels for all purposes. The original method of production consisted of pantograph engraving, some rigid-plastic labels and all metal labels still being produced in this way. For the bulk of labels, however, modern hot-press printing methods are used, and development work was undertaken to design new machines and to adapt commercial machines for the special requirements of the BPO.

## PANTOGRAPH ENGRAVING METHODS

Engraving, in the form of manually-cut wooden or metal plates, for producing ink designs on materials, originated in Northern Italy at the beginning of the fifteenth century. The invention of the pantograph principle is attributed to a Swedish Jesuit, Christof Schnerier, in 1603, and the first application of the principle in this country was by James Watt in 1807, on his sculpturing or copying machine.\* Brian Donkin used the pantograph principle to engrave dies for banknotes in 1820. The modern pantograph engraving machine, as its name implies, uses this principle to effect a reduction in the size of the legend, from the copy onto the item being engraved.

The BPO Factories Division have been providing labels, for General Managers' staffs for 80 years and have, in the main, used the pantograph type of machine for this work. Certain types of label are still produced in this way, such as those that are very large, made from metal, or from sandwich-type materials. A requirement for pantograph-produced labels is likely to persist and a number of improvements to the basic machine have been developed and introduced.

The principle of the pantograph, as illustrated in Fig. 1,

\* DICKINSON, G. W. H. Garret Museum of James Watt. *Transactions Newcomen Society*, Vol. 15, p. 77.

† Purchasing and Supply Department, Telecommunications Headquarters.

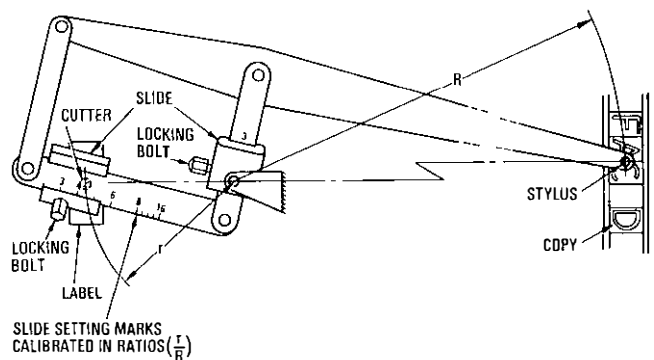

FIG. 1—Principles of the pantograph machine

permits a reduction in the character size from the copy to the label. Engraving a legend involves

- setting the pantograph to the desired ratio,
- setting up the copy in the holder and setting the cutting tool,
- setting up and clamping the label, and
- engraving the label.

Filling the engraved letters with the appropriate coloured wax follows as a separate operation.

The main modifications to the pantograph engraving machine are described below.

## Pantograph Setting

With the original machines, the correct reduction ratio was obtained by setting the 2 slides on their respective bars to engraved lines on the bars. Each slide was first released by turning its locking bolt, then tapped along the bar to attain alignment with the appropriate line, and the locking bolt finally retightened. This has now been improved by providing each of the locking bolts with tommy bars and one of the slides with a spring-loaded catch. The catch is held, against spring pressure, in the appropriate milled slot in the bar and the locking bolt tightened. The locating catch returns to its rest position under the action of the spring. The other slide is provided with a cam, having a number of flat edges against which the slide registers, and is then locked in position using the tommy bar on its locking bolt.

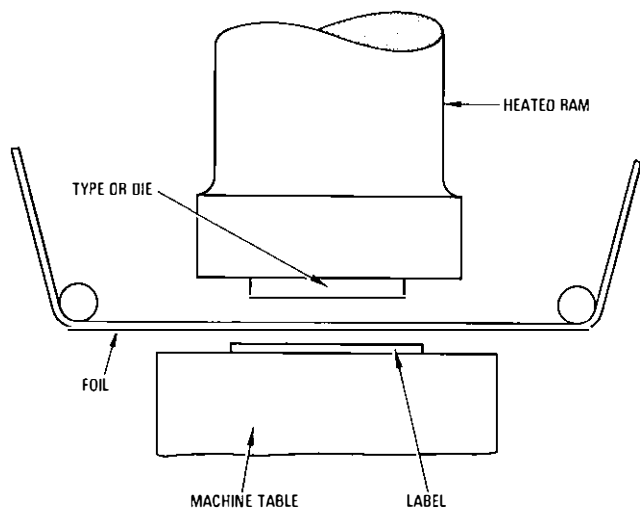

FIG. 2--Hot-press printing principle

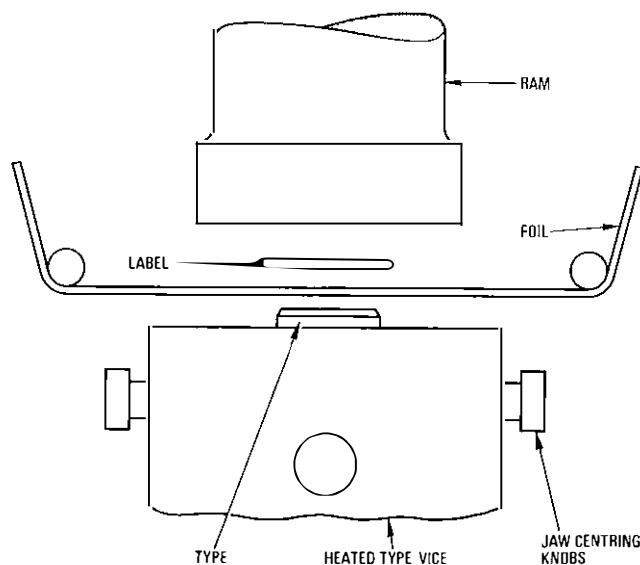

FIG. 3—Factories Division printing process principle

### Copy Holder

This consists of a flat metal plate, with wide shallow dovetailed slots, into which the brass copy is clamped. To facilitate easy positioning of the copy, the slots have been calibrated from a centre zero, and by aligning the ends of a legend on like dimensions, the copy is centralized in the holder. The engraved divisions of the calibration also permit the easy calibration of labels by choosing the appropriate ratio on the pantograph.

### Label-Holding Vice

The original design of vice had a cam clamping action, which held the label by point-contact only, permitting the ends of the label to bow upwards and not seat on the table. The improved vice has parallel jaws, with downward inclined edges, which ensure that the label is held onto the bed along its working length. One jaw is fixed, and the other moves under the control of a twist-type valve that operates a 25.4 mm stroke pneumatic cylinder connected to the jaw. To cater for larger labels, the cylinder and jaw assembly can be moved in discrete steps, giving a maximum jaw opening of 127 mm. The vice can accommodate labels up to 127 mm × 203 mm, but longer labels can be dealt with by sliding them through the vice as the legend progresses.

### Air Jet

A further improvement carried out was the fitting of a U-shaped air curtain, fed from a tube around the cutter. This blows the swarf away from the engraving and also cools the cutter, thereby preventing thermoplastic materials from welding to the tip of the tool.

## HOT-PRESS PRINTING METHODS

### Printing Rigid Labels

The principle of hot-press printing is illustrated in Fig. 2. Cartridge heaters, in the ram, heat the type which is fixed to the ram with adhesive, and the item being printed is held in position on the table in a simple frame. The stroke of the ram is activated by a vertical pneumatic cylinder operating through a toggle linkage. This gives a constant ram travel on each stroke and means that, to obtain a good clear print, the height at which the table is set is critical. Most

of the labels required lie within size limits of 50 mm × 50 mm and are one-off, or a very small number of labels bearing the same legend. Changing type on this sort of machine is a time-consuming operation, and a method has been developed which makes type changing quick and simple. Fig. 3 shows that the heating and typesetting process has been inverted. This enables the type to be assembled in a heated vice, which centralizes and clamps the legend. The operator has complete access to all vice-setting controls, as the vice is in the out position clear of the ram.

### Type Vice

The type is assembled loosely in the vice, in mirror image of the legend; the knobs are then turned, bringing in the opposing jaws simultaneously, thereby centring the type. The vice is designed to take 3 rows of type, but more rows can be accommodated by the judicious use of spacers, enabling one set of jaws to clamp 2 rows of type. The type is heated by conduction through the base of the vice, from 50 V cartridge heaters located in the body.

### Label Holder

A quick loading method had to be found for holding the label to be printed between the ram face and the foil, and to ensure that, when the vice and label holder moved into the printing position, the foil was correctly placed between the label and the type. This was achieved as indicated in Fig. 4. The spring-loaded holder, which is hinged to the vice, is provided with various frames to hold the many sizes of labels encountered. The holder hinges back through 180° towards the operator, thus making the changing of label frames easy, and allowing ready access for the setting of the type in the vice.

### Foil

The marking foil used has a polyester-film base, on which the coloured pigment is held by a heat-sensitive release agent. The heat from the type releases the pigment from the film base, and fuses it into the impression made in the plastic label.

### Printing

The following 3 main attributes control the production of a good clear print.

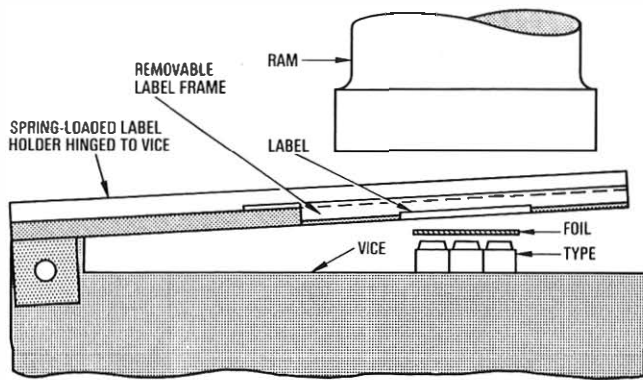

FIG. 4—Method of holding and positioning label

#### Type Temperature

The type must be at an approximate temperature of 130°C and, as the sensing element of the temperature control system cannot be on the type, the heating block in the vice is maintained at approximately 200°C to allow for radiation, convection and conduction losses. This gives a rapid warm-up to the cold type inserted when a legend is changed. The vice and heating block have sufficient thermal capacity so that, as soon as the operator has tightened the vice and inserted the label, printing can be carried out.

#### Pressure between Type and Label

To obviate the critical-height-setting characteristics of the original machine, the ram of the present machine is directly coupled to the vertically-operating pneumatic cylinder. This ensures a uniform load on the type within the effective stroke of the ram. In addition, to achieve a uniform quality of print when using one piece of small type, or a legend made up from a number of pieces of large type, a range of ram loads must be provided. To enable this range to be readily available, the machine has a 38 mm diameter cylinder for the low-load application and a 101.6 mm diameter cylinder for the higher loads. The force from the 101.6 mm diameter cylinder is transmitted to the printing ram by the through piston rod of the 38 mm cylinder. The controls on the machine also permit the air pressure to the cylinders to be varied and, by providing a calibrated scale around the pressure gauge, the operator can quickly set the machine to the appropriate pressure and cylinder for the particular legend involved (see Fig. 5).

#### Dwell Time between Type and Label

The dwell time on the early machines was measured from the start of the stroke of the pneumatic cylinder, giving a dwell time between the type and label that varied with differing ram speeds and stroke. This is overcome by arranging for the timing cycle to start from the time the label reaches a point within 127 μm of the surface of the type. Compensation is thus provided for the varying ram speeds and strokes, and for differing thicknesses in the materials being printed.

#### Printing Self-Adhesive Labels

A natural development from the hot-press printing of rigid-plastic labels is the printing of legends onto flexible self-adhesive vinyls and papers. Proprietary machines, designed to print on flexible materials, are available from several manufacturers. Some of each design have been purchased, suitably modified, and jugged and guarded to

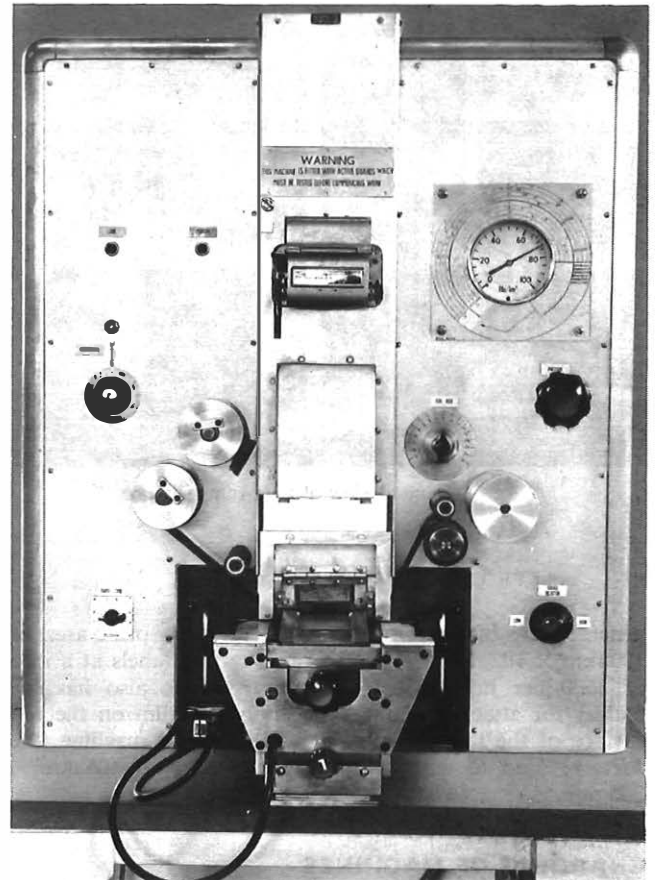

FIG. 5—Front view of machine designed by Factories Division

deal with the wide variety of labels ordered both in small and large numbers. Special-purpose machines have been designed in the BPO factory to meet the requirement for the economic production of one-off labels, required in-house, and not catered for by industrial proprietary machines.

The range of machines installed at the Cwmcarn factory can deal with print areas up to 406 mm × 305 mm and, in the main, use the commercial system of printing with the type held on the heated face of the ram. The foil and vinyl are traversed through the machine by a roller-feed mechanism as shown in Fig. 6 and, simultaneously with the printing action (as described for rigid labels), the vinyl is cut through to the backing paper to enable the label to be peeled off easily at the application stage.

On the machines that use the printing type held in the ram, a special form of type and chase are used. The type block has a T-shaped leg machined into its back face. On the ram, a T-slotted chase is fixed and this arrangement enables the type to be securely dovetailed into the chase, thus preventing pieces dropping out. Spring-loaded clips hold the pieces in close contact in the horizontal plane. Copper dies are used in place of type on self-adhesive work when justified economically by long-run or repeat orders. The dies are acid etched from copper plate, after a suitable photographic masking process has been performed. This process facilitates the printing of complicated artwork at a very competitive price.

The commercial self-adhesive-label machines are geared for long-run high-speed production, and some are capable of outputs of up to 300 labels/min. The labels are produced in 2 general forms, roll or sheet, with each label cut through to the protective backing paper for easy removal. Fig. 6 shows a



FIG. 6—General view of twin-ram machine

general view of a twin-ram machine, with a print area of 102 mm × 102 mm for printing and cutting labels at a rate of 3600 per hour. This particular machine also has the facility for attaching a protective polyester film on the top surface of the label. Fig. 7 shows the largest machine (the *Meteor*) used to date, having a print area of 406 mm × 305 mm.

### GUARDING OF MACHINES

To protect the operators of the machines from trapping their fingers in the machinery, various forms of guarding were considered; namely, mechanical, photo-electric infra-red and hand-capacitance types.

#### Standard Hot-Press Printing Machines

Owing to the need to keep realistic production times, totally-enclosed guarding was not suitable on this machine. Photo-electric infra-red guarding was also discounted because of the difficulties of application. Capacitive guarding was also thought unsuitable due to the possibility of the operator's hand capacitance giving a malfunction of the circuitry. Eventually, an active type of guarding was devised for the 2 danger points, using fixed contacts on horizontally-hinged flaps fitted between the fixed and moving parts of the machine. This provides a very sensitive protection system which automatically, and instantaneously, reverses the machine cycle to bring it back to the rest condition.

A further safety measure is the use of a 50 V centre-tapped supply for all guarding, control, heating and lighting circuits used on the machines.

#### Self-Adhesive-Label Printing Machines

Individual guarding of the danger points proved unsatisfactory for these machines, and the long-run nature of the work allowed totally-enclosed guarding to be used as shown in Fig. 6. The power-press cage-type guard was effective, but heavy and, therefore, a bureau-type roller-blind guard was developed. The electrically-interlocked doors at the front of the machine take the form of an articulated roller blind, made from acrylic slats held together at the ends by chain links. This facilitates safe and easy access to the operational areas of the machine. The rear of the machine is similarly guarded by sliding acrylic doors.



FIG. 7—Largest printing machine—the *Meteor*

#### Meteor Machine

This machine is the largest at Cwmcarn and is capable of printing large loose-leaf folders in addition to the full range of label work. It is necessary, therefore, to have full access and flexibility to enable maximum use to be made of this versatile machine.

A combination of fixed and photo-electric guarding (see Fig. 7) was found to afford the best protection with maximum flexibility. Fixed guarding made from acrylic sheet is used at the rear and sides of the machine, with the photo-electric guarding operative across the front. This allows the operator clear access to the machine for loading purposes, but during this operation, the beam is broken and the machine rendered inoperative. Only when the photo-electric beam is unbroken can the operator start the machine with the foot switch. The guarding circuitry is designed to reverse and restore the machine to normal, rather than stop it "dead" with the possibility of holding the trapped person.

### PRODUCTION

#### Rigid Labels

Fig. 8 shows a photograph of the hot-press printing machine flow-lines for rigid labels at the Cwmcarn factory. The incoming label requisitions, after recording, are distributed to the operatives with the label blanks, by a feed girl at the head of the flowline. When an operator has completed a requisition, the tray containing the label and requisition flows along the moving belt to the production inspection positions and, thence, to packing and the dispatch mail bag at the end of the line. These flowlines are capable of producing an average of 100 000 labels/week.

#### Self-Adhesive Labels

For small-quantity repeat labels, each machine is fed with legends made up in heated chases by a small team of setters.



FIG. 8—Hot-press printing flowline



FIG. 9—Setter making-up a legend

Fig. 9 shows a setter making-up a legend. This gives good machine utilization and minimum downtime, resulting in productions of 400 000 labels/week. For longer-run work, the machine can be attended by one operator who makes up the next legend whilst the previous one is being printed. The incoming work is fed to the most appropriate machine and production system to give the best economic result.

### Large Labels

The *Meteor* and *Comet* machines are used for large and heavy work. The chase from the *Meteor* weighs approximately 11.3 kg, and is normally removed from the machine by 254 mm long detachable handles. As this is a difficult and heavy operation for the setter, a modification to enable an easier and smoother typesetting operation was introduced. A detachable framework of slides and runners enables the chase to be transferred from its position on the ram and inverted to present the working face to the operator for easy typesetting (see Fig. 7). On completion of the setting operation, the procedure is reversed and printing commenced. This method of setting large-label printing is speedy and economical, particularly in the field of small-quantity requirements.

### CONCLUSIONS

The demand for rigid labels has increased at the rate of 10% per annum since the transfer of the work to the Cwmcaron factory, and this is expected to continue. The demand for self-adhesive labels is also increasing rapidly, and the Cwmcaron factory is being equipped with the necessary machinery and processes to meet the growth in demand.

The introduction of the hot-press printing principle and improved production methods has effected considerable savings and enabled realistic turn-round times for label orders to be achieved.

### ACKNOWLEDGEMENTS

Acknowledgements are made to Mr. K. Gilbert of the Science Museum, London, to Label Processes Ltd., and to Phillip Bros. & Ellis Ltd.

## Book Review

*Radar Precision and Resolution.* G. J. A. Bird. Pentech Press. 160 pp. 56 ill. £5.80.

The signal returned by a target to a radar aerial differs from the transmitted signal, in that it is subjected to a time delay and frequency shift, dependent upon the range and the target's radial velocity, respectively. Doubt as to the true time delay and frequency shift arises because of the transmitter waveform parameters; for example, the pulse width and number of radio-frequency cycles contained in the pulse. The uncertainty function, with which this book is concerned, defines this region of doubt, the smallness of the region denoting the precision of the radar system. Signal processing can be used to obtain the optimum precision performance, and techniques are illustrated by considering matched-filter and Fourier-transform receivers which are, basically, range and Doppler measuring systems, respectively.

The book is a mathematical treatise; its study is heavy

going, but every difficult step is proven, so that there are no gaps in the analyses, and reference to other publications is unnecessary. Worked examples are included. Thus, a complete analysis is given of the uncertainty function of a radar with a rectangular pulse and triangular frequency modulation. Similarly, signal processing is illustrated by a detailed study of matched-filter and Fourier-transform receivers when receiving, for example, rectangular pulse signals with sawtooth frequency modulation. The excellent presentation of Laplace, Fourier, fast-Fourier and Hilbert transforms, occupying about one third of the book, are worth studying by the communications engineer, although the topics are probably adequately covered in text-books readily available to him.

This is a well-written book for the radar specialist, but its purchase by a communications engineer may not be justified.

C. F. D.



# Support and Protection of Cables

N. E. FLETCHER†

U.D.C. 621.315.23: 621.315.212.029.62

*Since the introduction of multi-core cables into the underground network, it has been necessary to provide for their support and mechanical protection and, as the network has expanded and become more complex, the problems associated with support and protection have increased. This article outlines the history of cable support and protection, and describes some modern practices developed for the 60 MHz coaxial-cable routes.*

## HISTORY

Originally, all cables were lead-sheathed and, consequently, were heavy and inert. They could be bent and set into specific positions in jointing points, and only required support between the duct entry and exit. For this purpose, a range of cable bearers and brackets was developed. The bearers were made from galvanized-steel channel in a variety of lengths to suit the various sizes of jointing points. They were fixed vertically to the walls of the jointing point, and were provided with a series of holes in the channel sides for accommodating the brackets. The brackets were of galvanized cast iron, and were made in a range of lengths. They projected horizontally from the bearers, to which they were fixed by round steel pins located in the holes in the bearer sides. Bearers were fixed at intervals of approximately 0.9 m, so that a maximum-sized joint could be located between 2 brackets. Horizontal brackets were spaced vertically at 152 mm intervals, so that support could be provided for each layer of cables issuing from the duct nest. This spacing was somewhat greater than the standard vertical duct spacing in order to allow some spreading of cables within the jointing point.

With the introduction of pair-type carrier cables and, subsequently, coaxial cables, these support facilities proved to be inadequate. Therefore, additional support for the joint was provided by means of supporting bars fixed under the joint and supported on the 2 brackets at each end of the joint. These 2 types of cable were also considerably more fragile than the normal pair-type cable, and consideration was given to methods of protection. Two methods evolved: the first using asbestos-cement troughing to provide support and protection for a cable right across the jointing point, and the second using flexible steel tubing as a protection for the cable between the duct mouth and the joint position, at which a supporting bar was used.

With the introduction of polythene sheaths on pair-type cables, it was found that it was no longer possible to set a cable into position and expect it to remain there. Polythene has a tendency to return to its original extruded shape unless restrained in some way, and it was, therefore, necessary to provide, in addition to the brackets, some means of holding the cable in its correct position. A cable restrainer was developed which could be fitted to the supporting bracket and which was provided with slots so that a binder could be used to hold the cable in position. The binder adopted was a steel strip with a metal buckle, provided with a capstan for tightening the strips onto the cables.

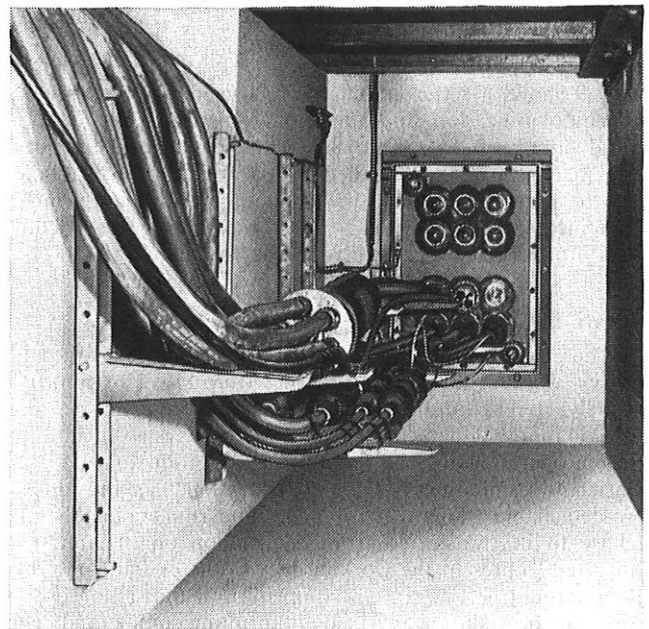

FIG. 1—Current-standard brackets and bearers

## CURRENT DEVELOPMENT

The methods of cable support and protection described above are still being used. Fig. 1 shows current-standard brackets and bearers in a telephone-exchange cable-trench.

Inspection of jointing points in the field indicates that they leave a lot to be desired. Many changes have occurred since the brackets and bearers were first designed, and they are not sufficiently flexible to accommodate the changing needs of the system. The adoption of fixed spacing between bearers may have been adequate originally, but the introduction of new types of cable, each with its own support requirement, has created considerable difficulties when intermediate bearer support is required. The abolition of multi-way duct in favour of single-way duct for all duct routes means that vertical spacings do not now have to be at fixed centres, and considerable advantage could be obtained with a vertically-adjustable bearer height.

When considering a new type of support system, the rigidity of the bearers is of some importance. Present methods of preventing cable creepage require the cable to be fixed at the duct mouth using an anchoring device, which has the effect of obstructing further cabling. A rigid-bearer system would

† Operational Programming Department, Telecommunications Headquarters.



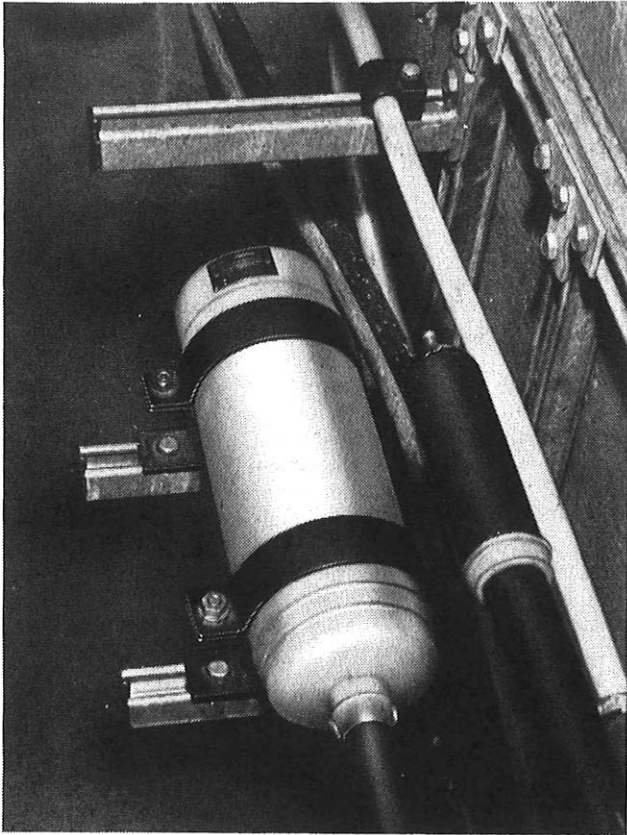

FIG. 2—Unit-type racking

provide facilities for cable anchorage at a point clear of the duct mouth and, thus, further cabling operations would not require the removal of cable anchors.

Any new support system must, therefore, provide

- (a) complete flexibility, allowing a bearer to be fixed at any point on the wall of the jointing point,
- (b) facilities for cable restraint as part of the support system,
- (c) protection for fragile cables or cables carrying large numbers of circuits, and
- (d) facilities for cable anchorage.

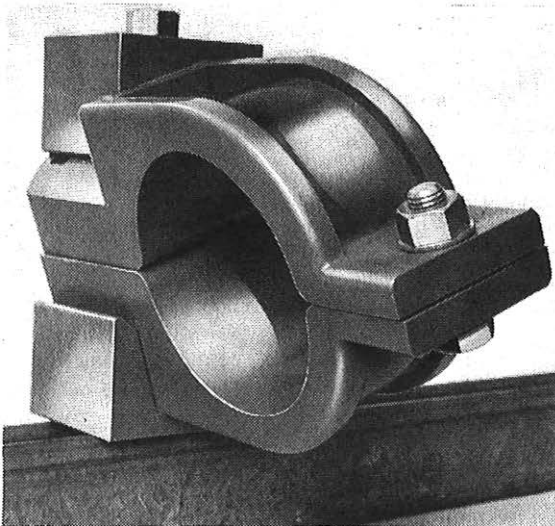

FIG. 3—BPO designed cable cleat in injection-moulded plastic, showing the angular-adjustment facility

### Unit-Type Racking

In a previous article,<sup>1</sup> the use of unit-type racking for cable supports in cable chambers was described. It was logical, therefore, to test the ability of the system to meet the needs of the external network. Trials were carried out using the standard systems, as marketed by Unistrut (Unirax), and these were reasonably satisfactory. Fig. 2 shows unit-type racking used for supporting cables and ancillary equipment.

The trials indicated that the system, as marketed, was not sufficiently flexible, and that close attention would have to be given to the galvanizing of the material.

At this time, development work was under way on the 18-pair 60 MHz coaxial cable for the London-Birmingham-Manchester route and, so, it was decided to proceed with the design of a new British Post Office (BPO) support system, based on the unit-type racking of Unistrut (Unirax) design, specifically for 60 MHz coaxial-cable routes.

It was decided that concrete inserts, as used for fixing internal racking, were not suitable for external work for 2 reasons. Firstly, the corrosion hazard had to be considered. The insert, once in position, could not be replaced, so its life would have to be the same as that of the structure. The rolled-steel section of the insert, even when galvanized correctly, would not have a life of that order. In addition, corrosion of the insert and fixing nuts would effectively destroy the flexibility required of the new system. The second reason was concerned with the structure itself. Because of the soil and traffic loads imposed on the structure, it is necessary to provide reinforcement near the inside surface of the walls. The provision of inserts would interfere with the reinforcement and, thus, necessitate changes in the basic structural design.

It was decided, therefore, that the basic fixing to the structure wall would be by rag bolts, cast into the concrete during construction as on all current designs of jointing points. This approach allows retrospective action to be taken if required. Horizontal movement of the brackets is provided by 2 horizontal channels fixed to the wall by the rag bolts. Vertical adjustment is obtained by vertical channels fixed between the horizontal channels at each support position. This arrangement allows a bracket to be positioned at any point in the support area. The cable brackets are made from channel-section similar to that used for the supports, and are welded to single-hole fixing plates designed to eliminate twisting. They will be supplied in a similar range of lengths to the present brackets.

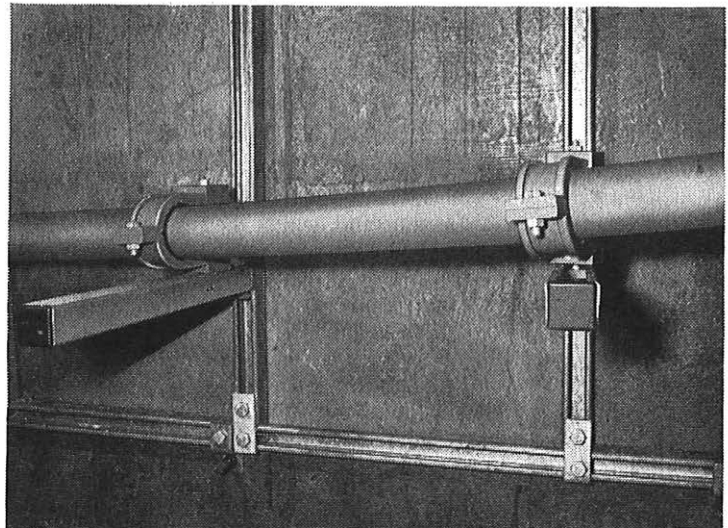

FIG. 4—Use of BPO cable cleats on unit-type racking for the support of an 18-pair 60 MHz coaxial cable

## Cable Cleats

The layout described forms a very rigid structure. It is, therefore, possible to use the cable brackets as anchorage points to eliminate cable creepage, and for cable restraint. The brackets are made with the open side of the channel upwards so that any form of cable cleat designed to fit Unirax channel can be used as a cable restrainer.

For the 18-pair 60 MHz coaxial cable, it was necessary to provide a cleat with a limited angular adjustment in both the vertical and horizontal directions. A cleat providing this sort of adjustment has been designed by the BPO, and will be used as part of the standard support system. The cleat is illustrated in Fig. 3. It uses a single-bolt fixing, and can be adjusted to the correct position before the bolt is tightened. It will be made in various sizes to suit the available range of type 375F cables. Fig. 4 shows the use of the cleat with unit-type racking, supporting an 18-pair 60 MHz coaxial cable.

The cleat is also effective as an anti-creepage device, and provision is made for an additional clamping bolt on the outer end of the cleat for this purpose. The cable is served with gauze, as used for the present anchoring system, and, where necessary, built up to the cleat size with PVC tape. The additional bolt in the cleat is used to clamp the cleat tightly onto the cable, the gauze spreading the load over a larger area of sheath. Thus, the rigid support system provides the required anchorage for the cable.

Where necessary, the support system also provides a facility for the provision of longitudinally-placed supporting

bars, needed for small joints on fragile cables. Because of the use of cleats for cable restraint, the cable centre-line is located above the top surface of the cable bracket, and straight supporting bars can be used, bolted directly to the cable brackets in most situations. The design of the supporting bar is, therefore, simplified, and production can be limited to a few standard lengths.

## CONCLUSIONS

The need for a new system of support for cables is recognized because existing methods lack flexibility and, as a result, many cables and joints are inadequately supported in practice. This situation results in early failure of sheath closures, and high maintenance costs. The system described is, at present, only available for the 60 MHz coaxial-cable routes. Further work is required to make the system acceptable for the network generally. The system is more expensive than that used at present, and the increased cost must be shown to be offset by a reduction in the number of service-affecting faults. The design and layout of manholes is also under consideration, and any decisions will affect the final choice of cable-support system.

## Reference

<sup>1</sup> FLETCHER, N. E., and COLEMAN, W. T. Leading External Cables into Telecommunication Buildings. *POEEJ*, Vol. 64, p. 94, July 1971.

---

# Conference on Plastics in Telecommunications, London, November 1974

U.D.C. 678.5: 621.39: 061.3

At a conference on "Plastics in Telecommunications", organized by the Plastics Institute and held at the Institution of Electrical Engineers (IEE), London, on 26-27 November 1974, the total attendance was close to 300, of which some 90 were from overseas. The opening address was given by Professor J. H. H. Merriman, C.B., O.B.E., President of the IEE. He opened by recalling his earliest student experiences of using materials such as textile-filled phenolic materials, when making components for the, then, very high frequency of 400 kHz. The advances in materials for cable insulation and sheathing, and for general use in switching equipment since those days had been enormous; it was now technically feasible to design telephone switching equipment almost entirely in plastic, except for the conducting paths. There were, however, hazards in the over-extensive use of plastics, and these dictated

(a) the need to guard against long-term wear-out failures in the reliability-conscious telecommunications business,

(b) the need to control flammability as some parts of telephone exchanges were valued at £175 000-£350 000/m<sup>3</sup>, and

(c) the need to understand fully the failure liability of plastic-encapsulated semiconductors, before allowing these components into the network in large quantities.

The conference itself was divided into 3 sessions: telephone exchange equipment, external plant and customer equipment, and cables and joints.

The first session included general papers on the use of plastics in current-design telephone exchanges from the UK, Germany, Holland and Sweden, and one from IBM indicating some likely trends resulting from the intrusion of com-

puters into telephone switching apparatus. The identifiable themes, common to all the papers, were

(a) the large economic advantages obtainable from modern engineering plastics, which permit close-tolerance moulding and automatic assembly of complex parts,

(b) the savings as a result of eliminating the need for manual adjustment of components, such as relays, when assembled from dimensionally-stable, precision-moulded parts,

(c) the very considerable product evaluation and testing necessary to under-pin the long life plus high reliability demanded by the telecommunications business, and

(d) the general acceptability of polycarbonate as a material for exchange applications.

These papers were followed by 6 on specialized topics, such as plastic encapsulation of semiconductors, flammability and fires, material specifications and a recently introduced moulding material, polybutylene terephthalate. The broad messages coming from these papers were as follows.

(a) Plastic-encapsulated semiconductors may never achieve long-life, high-reliability status if operated close to ambient temperatures, because of the moisture-permeation-induced failure modes. They may be satisfactory for short-life equipment, or for moderate-life equipment operated at temperatures high enough to dry up the plastic and low enough to be below temperatures which accelerate other modes of failure.

(b) Flammability is a complex problem and there is no one magic number or yardstick that can be used to rate materials or components for use in exchanges. Sensible precautions include the avoidance of very flammable materials for which alternatives are available; for example, clear acrylics for shelf covers, and ABS or polypropylene for structural parts. A combination of oxygen index and a practical ignition test on components seems to offer a working solution to the problem. Damage to other equipment by hydrochloric acid is a major worry.

(c) Specifications for materials should be as flexible as possible in allowing alternative materials to be offered, but they should be written so that effective surveillance by quality-assurance operations can be maintained. The present drive to harmonize specifications within the European Economic Community may pose problems, unless adequate representation is made by telecommunications users during the formative stages.

(d) Polybutylene terephthalate, the latest addition to the engineering plastics, has the following to offer: high rigidity, low-melt viscosity and fast cycle time, dimensional stability, and availability in flame-retarded grades.

The second session was concerned with external uses of plastics other than in cable. PVC duct, pioneered in France, is now widely used throughout Europe and provides a flexible, economic, water-tight and gas-tight underground duct system. Glass-reinforced plastics (mainly polyester) are beginning to be used in quantity for street furniture; for

example, cabinets and wall-boxes in France and also as the buried part of small joint boxes in the UK. The specialized uses of high-modulus materials, such as carbon fibre/epoxy in satellite bodies and antennae, provided an interesting contrast to the more mundane topics described earlier.

The 2 papers on customer equipment were complementary. One described tests needed to select materials for small decorative mouldings such as the telephone hand-set, where only PVC seemed to offer any challenge to the present front runner, ABS. The other dealt, in addition, with materials for larger housings; for example, consoles, where the flexibility of design, use of low-cost tooling, and good sound-absorption made cast-foamed rigid polyurethane an attractive material for small production quantities.

The third session on cables and joints was opened with 2 general papers on cables, one describing the current scene in France and the second a world review of the position of fully-filled cable. French practice on internal cables is similar to that used in the UK. The French PTT use cellular polyethylene insulation extensively on quad-trunk and balanced-pair cables for pulse-code-modulation systems, as against the almost exclusive use of paper in the UK. In coaxial cables, polypropylene is used for spacers as well as polyethylene, and the well-known *ballon* form of construction is also used. The review of fully-filled cable showed that this British invention has now penetrated 40 countries, and that the cellular polyethylene plus petroleum jelly filling is still the most popular realization of the basic fully-filled concept. Whereas the use in the UK has been restricted, so far, to cables of 100 pairs and below, the use of large fully-filled cables is being actively pursued in the USA (900 pairs) and Canada (400 pairs). A review of sheath closure techniques, including welding, was followed by a comprehensive paper on materials for submarine cables. The impression gained here is that, as a low-density low-loss material for the dielectric and a high-density material for the sheath, polyethylene is almost at the limits achievable by present technology. A promising newcomer for use inside submerged amplifiers is glass-filled polybutylene terephthalate. A look at one of the possible roads to the future was given in a paper on low-loss dielectrics for use at 10–3000 GHz. These materials were developed for the dielectric-rod waveguide (which is not a strong runner at the moment), but they could be of general interest in the microwave field. A method of extending  $Q$ -meter measurements on dielectric loss to 70 MHz was also described.

The conference was concluded by 2 papers on wire insulation. The first described the automatic process controls needed to make reproducible cellular polyethylene insulation; a more demanding task than with solid polyethylene. The last paper dealt with cross-linked wire coverings. Cross-linked PVC, in particular, seems to have many advantages, for jumper-wire use, over alternative materials. Cross-linked flame-retarded polyolefins also have properties suitable for heavy-duty applications.

J. C. H.

# A 24-Hour Digital Clock and Alarm Unit

K. BRETON†

U.D.C. 681.113.17.031.22: 621.397.743

*A 24 h digital clock and alarm unit, capable of storing up to 9 preset alarm times, has been developed. Its initial use will be to warn staff of the imminence of manual switches of television links, which must be performed at precise scheduled times. It will be provided at small television network switching centres, where the provision of complex automatic switching equipment is not justified.*

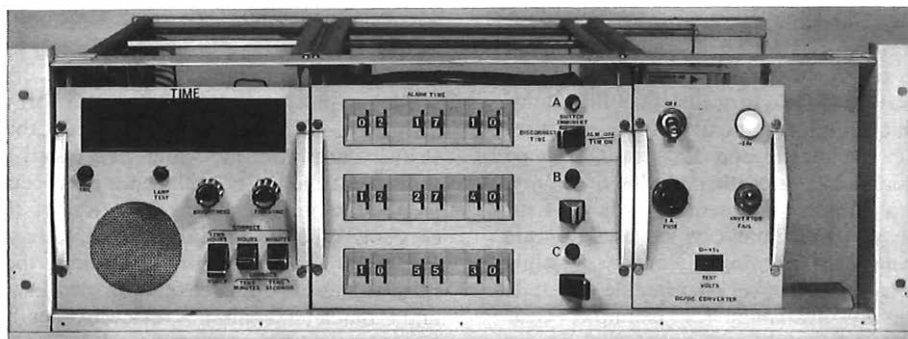

FIG. 1—Digital clock and alarm unit

## INTRODUCTION

The interconnexions between the British Post Office (BPO) television links, comprising the Independent Broadcasting Authority network, are changed at intervals during the course of a day, to accommodate changes in the origin and distribution of programmes. This service is provided by the BPO at television network switching centres (NSCs). At NSCs where large numbers of programme sources and destinations must be switched simultaneously, complex switching equipments are provided to operate automatically. These equipments are described elsewhere.<sup>1</sup> The timing of a switch must be accurate to within a few seconds. At smaller NSCs, switches are performed manually and a 24 h digital clock and alarm unit, coded as Equipment Time Alarm No. 1A, has been developed to call attention to the approaching time for a switching operation.

## DESCRIPTION

The clock equipment is constructed in 62-type equipment practice and occupies one shelf for 3 alarm times and 2 shelves when 4–9 alarm times are required. It is operated from standard BPO 24 V or 50 V battery power supplies. A photograph of the prototype equipment is shown in Fig. 1. It consists of 3 units, a clock unit incorporating the display, an alarm unit providing for entry of 3 alarm times and a power unit, which converts the station battery supply voltage to +5 V for powering the solid-state, transistor-transistor-logic, integrated circuits (ICs), which are used almost exclusively.

## FACILITIES

The clock equipment has the following facilities.

† Telecommunications Development Department, Telecommunications Headquarters.

(a) A 24 h, digital time display is provided on 7-segment light-emitting-diode (LED) units. The displayed digits are 15 mm in height and their brightness is adjustable. An LED test facility is available.

(b) Alarm times can be entered, in 10 s steps over the 24 h range, by manual rotation of thumb-wheel multi-switches. (The units-of-seconds digit is a dummy, permanently set at zero.) One set of these switches is provided for each alarm-time entry, and the time entered is displayed by engravings on the multi-switches. Any set of multi-switches can be made inoperative, so that unwanted alarm times marked by the switches are inhibited.

(c) Coincidence of clock time and an alarm-time entry causes an audible warning to be sounded from a loudspeaker, and a lamp glows adjacent to the multi-switch that has set the alarm.

(d) Operation of an ALARM-OFF key inhibits the alarm and replaces it with a speaking-clock announcement, enabling an operator to perform a switching operation precisely at a scheduled time. If a second alarm-time coincidence occurs while the speaking-clock announcement is on, the alarm tone is superimposed on the announcement.

(e) Restoration of the ALARM-OFF key restores the equipment to normal.

(f) A speaking-clock announcement can be switched on at any time to aid the setting up or correction of the time.

(g) Clock time can be set up, or corrected, rapidly by the operation of keys that apply 1 s pulses to step the counters of any time digit.

(h) The phase of the 1 s pulse, which drives the clock counters, can be varied to give a fine time adjustment.

(i) Failure of the 1 MHz crystal-controlled oscillator, from which the 1 s clock driving pulses are derived, operates a station alarm and causes a warning lamp to glow on the equipment.

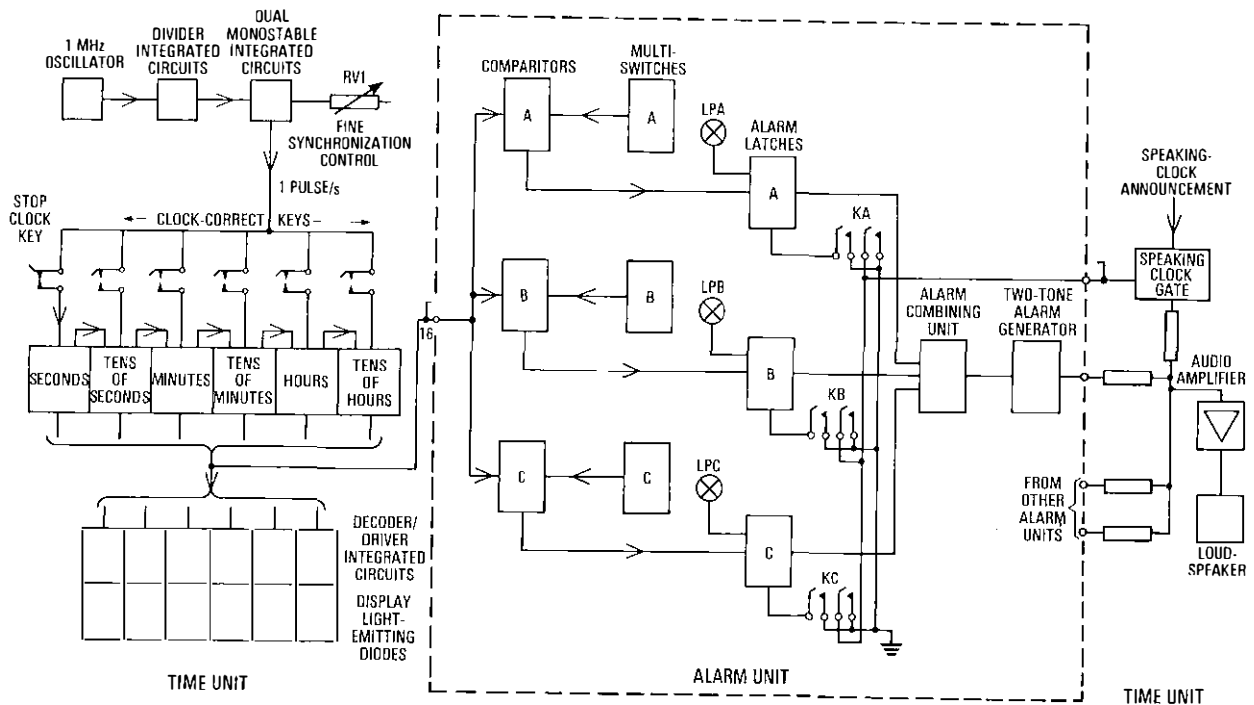

FIG. 2—Block diagram of clock equipment

### CIRCUIT OPERATION

A block diagram of the clock equipment is shown in Fig. 2. The output from a 1 MHz crystal-controlled oscillator is divided, in decades, to give a 1 Hz square wave. This is passed to a dual-monostable IC, which permits the phase of the output pulse to be varied under the control of an external potentiometer RVI, to give a fine time adjustment. Potentiometer RVI adjusts the duration of the output pulse from the first monostable circuit over a range of 800 ms, and the trailing edge of this pulse drives the second monostable circuit. The width of the output pulse from the second monostable is preset at 10 ms by an added time constant.

The output from the second monostable circuit drives the chain of binary-coded-decimal (BCD) clock counters. The binary-coded output from each of the clock counters resets automatically to zero on a count of 10 input pulses, but some of the counters must be reset before the full decade count is complete. For example, the tens of seconds and minutes are reset on the sixtieth input pulse. The early resetting is achieved by the use of NAND gates, arranged to sense the digits of the highest binary code required—60 in the case of minutes and seconds—and derive the reset signal. Resetting an IC automatically gives an output pulse to drive the next time counter.

The BCD outputs from the counters are capable of driving 10 other ICs. This is known as a fan-out of 10. One set of output leads is taken to decoder/driver ICs to operate the LED digital time display. An LED test key is provided which, when operated, causes all LED segments to glow. Alarm times are set up by rotating the thumb-wheel multi-switches to the point where their engravings show the time entry required. Their outputs are then marked in binary code.

The binary outputs from the clock counter ICs and the multi-switch marked outputs are compared in a set of comparators, one set of comparators being required for each alarmed time. The times are compared at 10 s intervals. This comparison requires 16 wires and up to 9 such comparisons may be made simultaneously; that is, the 16 output leads from the clock counters may be paralleled up to 9 times.

Three alarm units, each comprising 3 multi-switches, comparators, alarm latches, one combiner circuit and a

2-tone generator, can be commoned to the loudspeaker circuit, thus giving the maximum facility for 9 alarm times.

At the time coincidence between clock time and an entered alarm time, the comparators give an output to drive an associated alarm latch circuit. The latch circuit holds the alarm condition, and causes a lamp to glow which indicates the set of thumb-wheel switches causing the alarm. The outputs of 3 latch circuits are combined to operate a 2-tone generator which is made up from 3 Schmitt-trigger NAND gates. Operation of the 2-tone generator gives an audible warning from a loudspeaker. The operation of the ALARM-OFF key (KA, KB, or KC) releases the latch circuit, thus inhibiting the alarm and replacing it with the speaking-clock announcement by opening the speaking-clock gate. A second alarm, occurring during the speaking-clock announcement, superimposes the tone on the announcement.

### CONCLUSION

A digital clock and alarm unit has been developed that will assist staff at small NSCs to perform a switching operation on television links at a scheduled time. A reasonable time interval between the commencement of an alarm and the required link switching time is, say, 1 min, as this ensures adequate notice of the proposed switch, without unnecessary waste of an operator's time.

The clock could also be useful for other timed operations, and the output that operates the alarm could control other circuit functions.

It is possible to provide additional circuit features which permit the 1 MHz oscillator to be synchronized to the speaking clock. Suitable circuit designs already exist in other equipment,<sup>2</sup> in a discrete-component form, and these could now be realized more cheaply using ICs.

### References

- LLOYD, H. F., and STXSMITH, J. A Television-Network Switching Equipment to 625-Line Colour Standards. *POEEJ*, Vol. 60, p. 199, Oct. 1967.
- LANDER, A. C., and HOLLAND, G. E. V. A Highly Reliable Time-Pulse for Television Switching. *POEEJ*, Vol. 63, p. 8, Apr. 1970.

# New Cable-Repair Ship—CS MONARCH

U.D.C. 621.315.284: 621.315.29

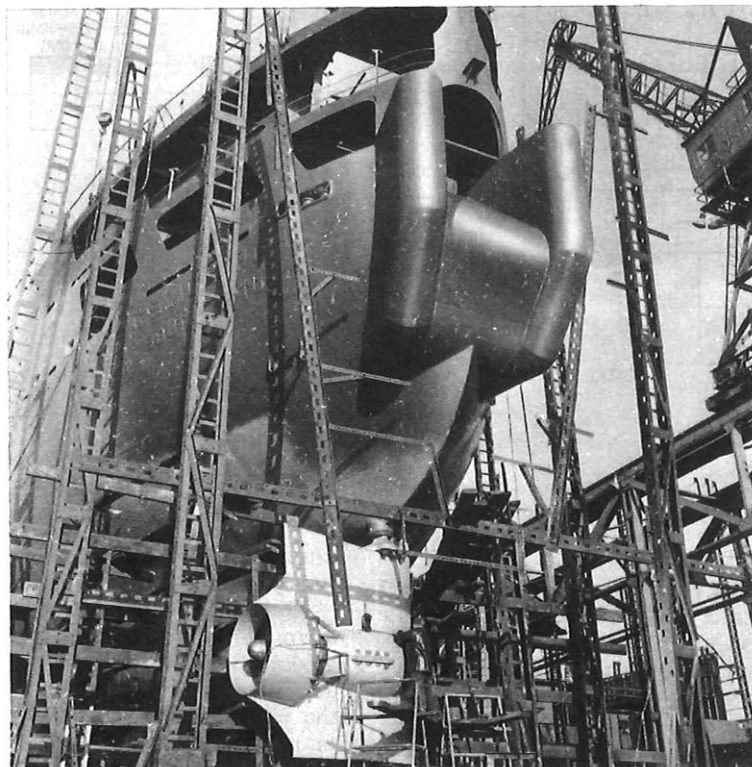

Fig. 1—Stern of CS *Monarch* with power rudder fitted, shortly before the launch date

On 29 January 1975, Lady Ryland named the first of 2 new British Post Office (BPO) cable-repair ships "CS *Monarch*" at a ceremony at the builders' yard. Regrettably, owing to unofficial industrial action at the shipyard, the planned launch of the new ship could not take place, but the full naming ceremony was carried through in the presence of about 100 invited guests. The launch of the ship finally took place on 12 February 1975.

The CS *Monarch* and her sister ship, which is being built by the same yard, are being constructed by Robb Caledon Shipbuilders Ltd. under a contract placed by the merchant bankers Samuel Montagu. The ships are to a BPO design, and supervision of the contract has been carried out by the BPO and its consultants. The BPO has agreed to charter the ships from Samuel Montagu for a period of up to 25 years; under the charter, the BPO will have just the same freedom to operate the ships as it would have if it purchased the ships itself.

The new CS *Monarch* is the fifth cable ship of that name; the first was built in 1830 and was taken over by the General Post Office from the International Telegraph Company in 1870. The first *Monarch* was a paddle-steamer of 96·94 kW (130 hp), which makes her a startling contrast to her 1975 successor. The new *Monarch* is the result of a number of years of study, model tests and design work carried out by the BPO Marine Division with the assistance of consultant naval architects and hydrodynamicists. The design brings

together in one vessel the best modern practices to improve cable loading, cable handling, sea kindliness and station keeping.

The new ship has a gross weight of approximately 3500 t, and she is 94 m long, has a breadth of 15 m and an operating draught of 4·8 m. Her main propulsion unit is powered by twin 1·94 MW (2600 hp) diesel engines, driving a 2-input, single-output gearbox which drives the controllable-pitch propeller. In addition, the main gearbox also drives two 1200 kVA alternators to provide power for a retractable bow thruster unit and an active-rudder thrust-unit (see Fig. 1), which develop 4·3 t and 4 t of thrust respectively.

The maximum cable-carrying capacity of the ship is 1430 t, disposed in 10 cable tanks. To improve the speed of cable-loading operations, and thus the turn-round time of the ship, the 4 main cable tanks, which are capable of taking cable loaded and coiled in the conventional manner, have been designed to take, as an alternative, pre-loaded pans of cable through hatch trunks in the ship. These cable pans will be drawn from the stocks at the new cable depot at Southampton. This pan-loading technique may be likened to containerization in the general cargo field.

Navigational equipment for the ship is consistent with the demands of modern cable operations and will include gyro compasses, radar, Decca Navigator, LORAN and precision depth recorders.

The new ships are primarily designed for cable-repair operations around the British Isles and on the North-West European continental shelf, but because of their design, they will be capable of deep-water work beyond that area.

CS *Monarch* will now complete her fitting-out and undergo trials leading to her commissioning and bringing into BPO

service later in 1975. There can be no doubt that she will be a valuable addition to the BPO cables fleet. R.E.G.B.

It is hoped to publish a more comprehensive article describing the new cable-repair ships in a subsequent issue of the *Journal*.

## 120 Mbit/s Digital Line System Inauguration

U.D.C. 681.327.8; 621.376.56; 621.395.345

Since the initial introduction in 1968, the British Post Office (BPO) has installed more than three-thousand 24-channel pulse-code-modulation (PCM) systems in the junction network, providing more than 1.6-million channel kilometres.

From 1977 onwards, the 24-channel system will be superseded by a 30-channel system which conforms to CCITT\* recommendations and is being adopted by most Western-European administrations. These systems will be installed as a continuing means of providing junction circuits, and also as part of the planned introduction of digital transmission into the trunk network from 1978 onwards.

To provide the long-haul digital-transmission capability needed for the trunk network, the BPO initiated the development of 120 Mbit/s digital line systems by the UK telecommunications industry. The first, developed and installed between Guildford and Portsmouth by Standard Telephones and Cables Ltd., was handed over to the BPO in December 1974, and will be evaluated during the next few months. A second system, developed jointly by GEC and Plessey, will be installed between Portsmouth and Southampton during 1975, the 2 systems together providing a route approximately 100 km in length.

To provide access to the line system for the 2.048 Mbit/s signals from the 30-channel PCM multiplex, 2 stages of digital multiplexing are provided. In the first stage, 4 plesiochronous† signals each at 2.048 Mbit/s are multiplexed to generate 8.448 Mbit/s, in conformity with a CCITT recommendation for the second order of a digital hierarchy. In the second stage, 14 such 8.448 Mbit/s signals are then multiplexed to generate 120 Mbit/s, corresponding to 1680 voice channels.

The 2.048 Mbit/s to 8.448 Mbit/s digital multiplex equipment has been developed by GEC; the second stage from

8.448 Mbit/s to 120 Mbit/s, has been developed by Pye TMC Ltd. It is believed that the 120 Mbit/s system is the first fully-engineered system in Europe having a digit rate in excess of 100 Mbit/s, and represents an important step forward in the field of digital communications.

Since the BPO has a substantial investment in installed 1.2/4.4 mm coaxial pair cable, an important design objective for this new digital line system was that it should be physically compatible with the present range of frequency-division-multiplex (FDM) systems for these cables. This objective required that the power-feeding, regenerator-spacing and regenerator-housing requirements and speaker facilities should be virtually identical with those currently in use for 12 MHz FDM systems. These objectives have been realized as shown by the principal parameters given in Table 1.

The overall arrangement of the line system and multiplexing is shown in Fig. 1 and Fig. 2.

The digital signal transferred across the interface from the multiplex equipment is at the binary rate of 120 Mbit/s and

**TABLE 1**  
Principal Parameters of 120 Mbit/s Digital Line System

Binary Information Rate	120 Mbit/s
Error-Rate Objective	2 in $10^7$ for 2500 km
Regenerator Spacing	2.1 km nominal maximum (equivalent to 78 dB maximum insertion loss at 45 MHz)
Power Feeding	250-0-250 V maximum, 50 mA constant current
Distance between Power-Feeding Stations	30 km nominal (15 regenerator sections)

\* CCITT—International Telegraph and Telephone Consultative Committee.

† Two signals are plesiochronous if their corresponding significant instants occur at nominally the same rate.

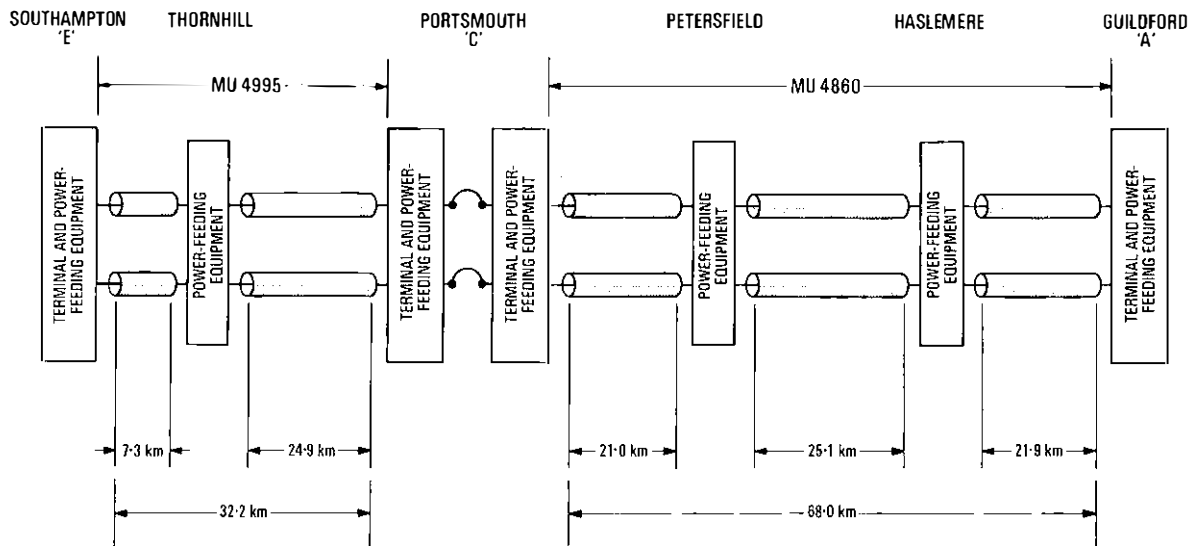

FIG. 1—Block diagram of line system

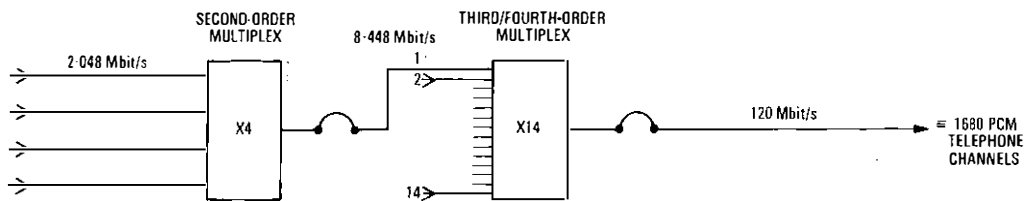

FIG. 2—Block diagram of multiplex equipment

is encoded in HDB3<sup>‡</sup> to ensure that there are adequate timing transitions in the signal. In order to reduce the line-symbol rate, the HDB3 signal is recoded by converting from words of 4 binary digits into words of 3 ternary digits. This reduces the binary digit rate of 120 Mbit/s to a ternary symbol rate of 90 Msymbol/s, and the resultant energy spectrum is maximum at 45 MHz (for a random signal).

The line system has built-in error-monitoring facilities so

<sup>‡</sup> HDB $n$  is one class of highly-redundant ternary codes known as *high-density bipolar* of order  $n$ , where  $n$  is the maximum number of consecutive zeros in the HDB $n$  signal. In this case  $n = 3$ .

that, if a fault develops in a regenerator, this can be located by transmitting a pre-determined digital sequence from the transmit terminal equipment, which enables the faulty regenerator section to be identified.

Present plans are that 120 Mbit/s systems should be brought into service by 1978, but as higher-capacity digital systems will be required for higher-growth-rate routes, proposals are now being formulated for the study of the feasibility of a digital line system on 1.2/4.4 mm coaxial pairs having a binary digit rate in the range 400–600 Mbit/s.

G.H.B.



# Variety Control

S. LIFFORD, C.ENG., M.I.MECH.E.†

U.D.C. 658.5:519.283:165.63

*This article highlights the main advantages to be gained by variety control, outlines the results achieved in the first 3 years and discusses the cost of variety. The development of the methods of estimating the cost of variety and the savings to be obtained from variety control are also discussed.*

## INTRODUCTION

The need for a variety-control group was underlined in an early value-analysis report on the rationalization of telephone cords; this report recommended that "to avoid proliferation of cord types and other equipments, an officer should be made specifically responsible for variety control . . .". A small group was subsequently set up, in the Value Analysis Branch of the British Post Office (BPO) Telecommunications Headquarters (THQ), early in 1971 on an experimental basis, to test the worth of the activity in relation to stores items. The results achieved in the first year, although by no means startling, showed that it would be worthwhile to keep the activity as a permanent feature of Value Analysis Branch work. In the exchange-equipment field, the Operational Programming Department of THQ are successfully applying variety control to effect cost savings on both manufacturing and installation work.

## ADVANTAGES

The advantages of variety control are self evident. In addition to limiting the number of similar items stocked, it is an effective method of containing rising costs. It enables larger orders to be placed for fewer items, thus giving manufacturers longer production runs with a lower cost per item. Reducing the number of different items held in stock diminishes the total quantity of stocks held and reduces administrative costs. Savings can also arise from a reduced training commitment and maintenance demand. A point not generally given the full attention it merits is that, by using an existing item, not only are development time, drawing and production-tooling expenses saved, but use is made of an item which has already been proved in practice and for which spares provision has been made.

## ORGANIZATION AND METHOD

The variety-control activity has 2 main objectives: control to prevent proliferation caused by the addition of unnecessary new items, and the reduction of existing ranges of items. The control activity is exercised by vetting all requests for allocation of titles, and reduction of existing ranges is effected by the examination of the need for ranges of similar items, low-demand items and obsolete items.

## THE FIRST YEAR

During this period, 606 requests for codes for equipments and components were received. In 470 cases, the need for coding was self-evident and examination of the remainder

led to only 5 of the requests being withdrawn. It was clear from this that, in general, there are normally good reasons for the introduction of additional equipment items and most component items.

However, it was not clear how many non-standard sub-assemblies and components were introduced in the additional equipment items, as it is often easier to ask for a new component to be designed than it is to design new equipment around existing components. An example of this is the handset cord for the Loudspeaking Telephone No. 4 which has conductors 102 mm longer than the standard cord, owing to the terminals being placed further away from the grommet hole. Another case is the need to stock 2 types of handset cord because of differences in terminations, one requiring a 6 BA spade tag and the other an 8 BA. A third case involved the amplifying handsets for the 700-type telephone. Two types were introduced, one operating from line current and one operating from a local battery. Each of the 2 types had a cord different from the cord used on the standard handset, and this entailed 2 additional cords being held in stock. Subsequently, the development group designed a single amplifying handset which not only meets both of the above operating requirements, but uses the standard handset cord and thus makes the 2 additional cords obsolete.

**TABLE 1**  
**Variety-Reduction Results for First Year**

Item	Vocabulary Entries to be Deleted	Saving/Annum per Entry (£) Note	Estimated Savings/Annum (£)
Boxes Battery Lclanché deleted from vocabulary	5	100	500
Acrylic 706 telephone mouldings, withdrawn from vocabulary	6	100	600
Rationalized wood-screw range	128	250	32 000
Rationalization of volt-meters	9	100	900
Cords Test Rationalization	15	100	1 500
Totals	163	—	35 500

Note: £250/annum saving for deletion of an entry which correspondingly increases the demand for other items, and £100/annum saving for deletion of obsolete or moribund items

† Purchasing and Supply Department, Telecommunications Headquarters.

The effort expended on variety reduction was more fruitful and resulted in agreement to delete 163 vocabulary entries relating to acrylic telephone mouldings, wood screws, voltmeters and test cords, as shown in Table 1. A proposal was also made to rationalize the ammeter range in a BPO specification to those shown in the relevant British Standard, thus effecting a reduction of 56 in the range listed.

## SUBSEQUENT RESULTS

During the second year, which saw a 38% increase in the number of requests for codes, only 9 requests were withdrawn. There was, however, some evidence of an increasing readiness on the part of designers to consult with the variety-control group. This attitude was probably encouraged by a variety-control leaflet issued during the year, and by the inclusion, in the normal value-analysis training seminars, of short talks and instances of advantages obtained from variety control.

Again, from the variety-reduction activity, agreed deletions from the vocabulary amounted to 214, as detailed in Table 2.

During the third year, agreed deletions amounted to 236 and Table 3 gives the details. Overall figures for 1973-74 from the Supplies Division of THQ show that, although just over 800 coded items were added to the vocabulary of engineering stores, well over 1300 coded items were deleted from the vocabulary. This again indicates a general awareness of the need to delete unwanted and moribund items from the vocabulary; that is, variety reduction.

**TABLE 2**  
**Variety-Reduction Results for Second Year**

Item	Vocabulary Entries to be Deleted	Savings/Annum per Entry (£) Note	Estimated Savings/Annum (£)
Rationalization of pre-700-type telephone-instrument cords	80	100	8 000
Rationalization of twist drills	97	100	9 700
Rationalization of 700-type telephone cords (preliminary investigation)	11	100	1 100
Parts 10, 11 and 13 DBU/260 made obsolete; replaced by 30/, 31/, and 33/ . . . (Telephone 710 buttons)	3	100	300
Rationalization of Ammeters 19, 31, 35 and 36; make obsolete and meet small requirements by local purchase	15	250	3 750
Rationalization of Voltmeters 31, 40 and 66; make obsolete and meet small requirements by local purchase	8	250	2 000
Totals	214	--	24 850

Note: £250/annum saving for deletion of an entry which correspondingly increases the demand for other items, and £100/annum saving for deletion of obsolete or moribund items

## THE COST OF VARIETY

The most difficult aspect of the variety-control activity is attempting to put monetary values to the costs of adding a vocabulary entry, or the savings to be obtained from a deletion of an item code. The first method used to evaluate costs was to establish the average annual cost per vocabulary entry of

- (a) ordering stores,
- (b) receiving, stocking and issuing stores, and
- (c) collection of stores by area staff.

A chart was drawn up (see Fig. 1), showing the various activities involved, starting from the technician in the telephone area, through the section stock stores, area stores office to the Supplies Division and Contracts Division of THQ. The 4 main cost sections involved were

- (a) field staff requisitioning and collecting stores (first column of Fig. 1),
- (b) activities in section stock stores and area stores office (second and third columns of Fig. 1),
- (c) Supplies Division's activities (fourth, fifth and sixth columns of Fig. 1), and
- (d) Contracts Division's activities (seventh column of Fig. 1).

**TABLE 3**  
**Variety-Reduction Results for Third Year**

Item	Vocabulary Entries to be Deleted	Savings/Annum per Entry (£) Note	Estimated Savings/Annum (£)
Dials Automatic Dummy No. 3 Ivory and Red made obsolete and surplus to requirements	2	100	200
Part 1/DBU/264 made obsolete and replaced by 3/ . . . (Telephone 706 button)	1	100	100
Part 1/DBU/199 colour range reduced from 7 to 3 (cord grommet dummy)	4	100	400
Resistor Spool No. 1 and 2 (Mk. 3) made obsolete	29	100	2 900
Labels 349 and 350 made obsolete	2	100	200
Soldering Irons Non-Electric; withdraw and use electric types	5	250	1 250
Delete hand files and make local purchase	17 20	250 100	4 250 2 000
Box Cord Repair make obsolete	1	250	250
Wallboards Grey; rationalize and metricate sizes, reduce variety from 7 to 3	4	250	1 000
Various tools, section STA of Vocabulary	77 74	250 100	19 250 7 400
Totals	236	—	39 200

Note: £250/annum saving for deletion of an entry which correspondingly increases the demand for other items, and £100/annum saving for deletion of obsolete or moribund items

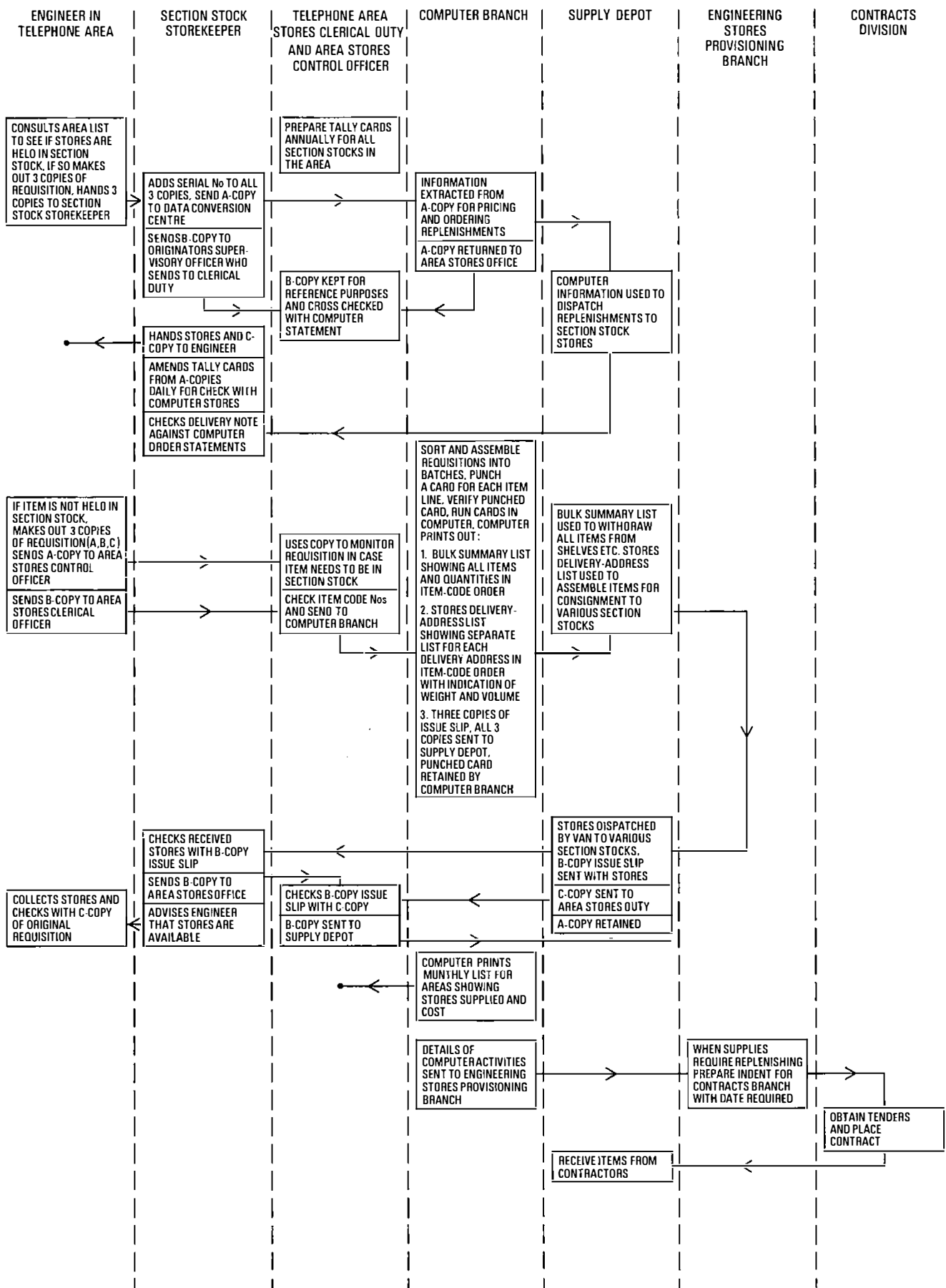

FIG. 1—Activities involved in procuring and issuing vocabulary items

**TABLE 4**  
**Cost of Procuring, Stocking and Distributing**

Item	Setting-up Costs (£)						Fixed Annual Charges (£)		
	Vocabulary Entry	Central Stores Depots	Section Stock Stores	Factories Division Repair Process	Packing Design	Total	Indent	Tendering & Contract	Total
Telephone 746 Grey	120	48	1110	24 500	150	25 928	50 0·0025	50 0·0025	100 0·005
Teleprinter 15B	20	8	185	115 000	75	115 288	20 0·0133	50 0·0333	70 0·0467
Equipment PABX SA 8100	20	8	185	30 000	150	30 363	70 0·1220	50 0·0871	120 0·2091
Block Terminal 41	20	8	185	Nil	Nil	213	2 0·00004	50 0·00102	52 0·00106
Anchor Screw Stay	20	8	185	Nil	Nil	213	2 0·00007	50 0·00185	52 0·00192
Nippers Diagonal Cutting 5 in	20	8	185	Nil	Nil	213	2 0·00003	50 0·00068	52 0·00071
Cord Instrument 4/121AT Grey	20	8	185	Nil	Nil	213	20 0·00086	50 0·00216	70 0·00302
Cable PCUT 200 pair 0·5 mm	20	8	185	Nil	Nil	213	180 0·00033	50 0·00009	230 0·00042
Meter Multi-Range 12B/1	20	8	185	Nil	Nil	213	25 0·00307	50 0·00614	75 0·00921

### Field Staff Costs

A survey by the Telecommunications Management Services Department of THQ showed that the average time spent by fitters and installation parties in collecting stores varied between 2-4 %. The national total of staff using section stocks stores was approximately 37 400 (from the summary of area staff trees, 1971) and it was assumed that, on average, they spent 2½ % of their time collecting stores. Using the, then, current UK wage rates with overheads for the Technician IIA grade, a figure of £1 770 000/annum was derived.

### Section Stock Stores and Area Stores Office Costs

Using figures from one area, having a stores staff typical of the average for 17 areas, and taking account of stores accommodation and staff with their appropriate overheads, a figure of £5 712 600/annum was obtained.

### Supplies Division Costs

From a Supplies Division, Warehouse Methods Branch report, which calculated the cost of receiving and the cost of stocking and issuing stores on an *item-line\** basis, an annual cost of £2 069 730 was deduced.

### Contracts Division Costs

The division places an average of 5500 contracts/annum for engineering stores, at an average cost of £100/contract, giving an annual total figure of £550 000.

\* A quantity of an item either issued or received.

### Total Costs

From this evaluation, total costs of £10 102 330/annum were estimated which, if spread evenly over all the 22 500 coded items in the vocabulary, would give an average figure per vocabulary entry of approx £450/annum.

### SAVINGS FROM VARIETY CONTROL

For the purposes of the variety-control activity, it was assumed that the £450/annum would be the cost involved in adding an additional item to the vocabulary of engineering stores. An estimate was made of the savings which would be made if a range of items were reduced by one. It was assumed that the demand for the deleted item would create a corresponding increase in the demand for the remaining items in the range. The figure arrived at, by estimating the savings in each of the above cost sections, was £250/annum for one vocabulary entry deleted from a range of items. A third figure of £100 was also estimated as the saving per annum by the deletion of an obsolescent item from the vocabulary. Whilst these 3 figures could be used as a rough check on the usefulness of the variety-control activity, a more sensitive system is needed to enable the decision to delete or not to delete to be made more precisely, and to quantify the savings more accurately.

### SECOND COST EVALUATION

The first cost evaluation was based on determining global costs and dividing these by the total number of vocabulary entries to get an average cost per entry. For the second cost evaluation, an alternative method of taking specific items and

**TABLE 5**  
**Cost of Procuring, Stocking and Distributing**

Item	Varying Annual Charges (£)											Total
	Interest Repayment	Accommodation		Receiving		Issuing		Stocking		Central Stores Dispatch	Quality Assurance	
		Section Stock Stores	Central Stores Depots	Section Stock Stores	Central Stores Depots	Section Stock Stores	Central Stores Depots	Section Stock Stores	Central Stores Depots			
Telephone 746 Grey	293 832 0·5120	8651 0·0125	4555 0·0064	4369 0·0063	1780 0·00254	58 140 0·0840	3234 0·00462	18 780 0·0271	1473 0·00210	840 0·00120	4627 0·0048	400 281 0·6636
Teleprinter 15B	166 804 66·70	7669 1·1660	121 0·0484	977 0·150	221 0·08840	1975 0·30	400 0·1600	886 0·1350	183 0·0732	104 0·0416	3204 1·2810	182 544 70·3850
Equipment PABX SA 8100	39 000 68·0	7340 12·80	350 0·6098	1140 2·0	245 0·4268	668 1·160	148 0·2578	542 0·940	202 0·3519	115 0·2003	2482 4·32	52 232 91·0670
Block Terminal 41	18 440 0·124	2052 0·0138	1585 0·01064	1557 0·0104	253 0·00170	7751 0·0520	694 0·00466	2792 0·0187	210 0·00141	120 0·00081	358 0·0024	35 812 0·2405
Anchor Screw Stay	10 163 0·3770	7794 0·2890	6546 0·2430	716 0·0266	773 0·02968	4800 0·1780	1404 0·05390	1655 0·0614	640 0·02457	273 0·01048	69 0·0026	34 833 1·2962
Nippers Diagonal Cutting 5 in	5867 0·080	180 0·0025	55 0·0008	630 0·0086	361 0·00507	4805 0·0655	1605 0·02255	1631 0·0222	449 0·00631	170 0·00239	59 0·0008	15 812 0·2167
Cord Instrument 4/121 AT Grey	382 0·0165	343 0·0148	515 0·02239	217 0·0094	97 0·00422	2108 0·0910	172 0·00747	697 0·0301	79 0·003435	21 0·000913	15 0·00064	4646 0·1976
Cable PCUT 200 pair 0·5 mm	59 840 0·110	7344 0·0135	220 0·00153	514 0·0009	133 0·00092	3900 0·0072	322 0·00224	1471 0·0027	73 0·00051	62 0·00043	261 0·0005	74 140 0·1404
Meter Multi-Range 12B/1	9956 1·2230	504 0·0619	270 0·0332	458 0·0563	245 0·0301	1071 0·1316	464 0·0570	459 0·0564	201 0·0247	116 0·01425	261 0·0321	13 997 1·7210

costing them in detail was adopted. It was decided to attempt to get all the costs of procuring, stocking and distributing a selected list of items as far as the section stock stores counter in the areas. The costs would be under 3 main headings: initial or setting-up costs (once-and-for-all costs), fixed annual charges and varying annual charges (according to volume of business). The list should, if possible, include items which, between them, exhibit all of the following characteristics:

- (a) large and small demand rates,
- (b) light and heavy weight,
- (c) large and small physical size,
- (d) high cost and low cost,
- (e) complex and simple, and
- (f) cover several vocabulary sections.

The items selected are shown in Tables 4 and 5 which give the costs obtained for each of the 3 main headings selected and for the constituent activities into which the main headings were divided. The costs obtained are based on the best estimates available by people actually involved in supervising the activities; that is, no measured times have been taken. The section stock stores costs were based on figures obtained from 38 section stock stores, and the Supplies Division and Contracts Division costs were obtained from those divisions. The Supplies Divisions figures used a ranking system to allow for volume of business, size and weight of item and cost of item, using the Telephone 746 grey as the datum. The figures for raising the indents for the various items were, however, derived from recent or current indents for the range of items.

Tables 4 and 5 show 2 figures for the items under each annual charge heading. The top figure is the total annual

charge for that activity, and the lower figure is the total annual charge divided by the annual quantity of the item involved in that activity.

From these figures, it can be demonstrated that the annual charge/item (excluding setting-up costs) for the items examined are as shown in Table 6, and this could be one basis for estimating the costs of administering various types of vocabulary item. At first sight, these percentages seem to be on the high side, but they reflect the cost estimates obtained from the various sources, and they include a 10% interest charge which, for simplicity, has been based on the assumption that a quantity equal to approximately 1 year's demand for the item is normally in the supply pipeline. It is

**TABLE 6**  
**Annual Charges**

Item	Annual Charge/Item (Percentage of capital cost of the item)
Telephone 746 grey .. ..	13
Teleprinter 15B .. ..	10·6
Equipment PABX SA8100 .. ..	13·4
Block Terminal 41 .. ..	19·4
Anchor Screw Stay .. ..	34·4
Nippers Diagonal Cutting 5 in .. ..	27
Cord Instrument 4/121 AT grey .. ..	120
Metre of Cable PCUT 200-pair .. ..	13
Meter Multi-Range No. 12B/1 .. ..	14

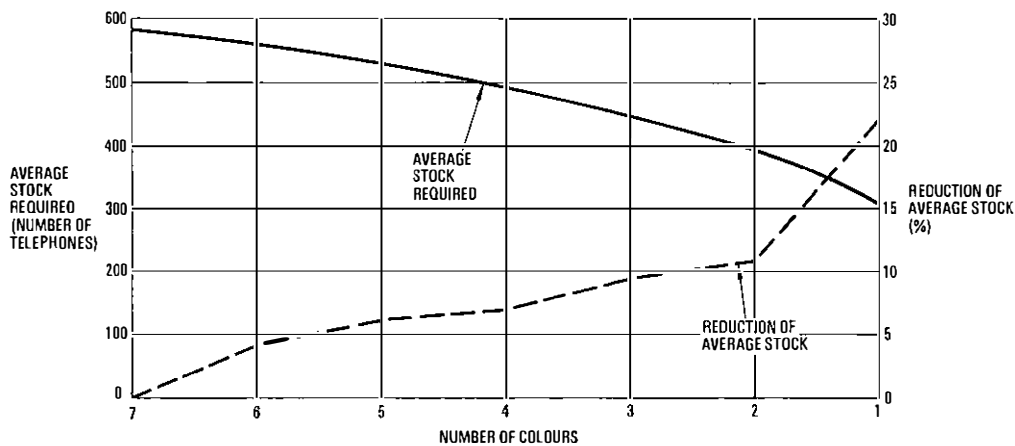

FIG. 2—Reduction in stockholding owing to variety reduction of colour range of Telephones 746F

proposed to carry out cross checks to establish that the estimates are realistic and to explore other possible bases for estimating costs. If the figures can be substantiated, it will show that the variety-control activity is very rewarding.

### SAVINGS FROM VARIETY REDUCTION

When a basis for estimating the costs of administering vocabulary items of varying types has been devised, it will be necessary to extend this to determine the savings resulting from a reduction in variety of a range of items. A start has been made by trying to determine what effect on stockholdings a reduction in the range of colours of telephones would have. Telephones 746 are supplied from central stores depots to section stock stores under the Engineering Stores Control and Pricing (ESCAP) system. This is a computer-controlled system, where the parameters for each item, at each section stock stores, are recalculated for each 4-weekly period. By operating these parameters manually, and using the ESCAP computer statements giving the pattern of demand over a period of 1 year, a good estimate can be made of the average stock of Telephones 746 held in section stock stores. This was done for 2 section stock stores. An assumption was then made that the colour range was reduced from 7 to 6, and that the demand for the least-popular colour was evenly spread over the remaining 6 colours. The average stock figure was recalculated using this assumption. This was repeated for a reduction in colours to 5, 4, 3, 2 and finally down to one; in each case, the average stockholding was derived. The figures for the 2 section stock stores were combined and a graph produced showing how the average stock required to meet the demand pattern changed with the reduction in the range of colours, (see Fig. 2).

Fig. 2 also shows the percentage reduction in average stock as the colour-range reduces. Assuming that these 2 section stock stores are typical, and translating this hypothetical situation into monetary values, at the end of December 1973, section stock stores held 158 933 Telephones 746F. Therefore, a reduction from 7 to 6 colours would reduce stocks by 6837 telephones, giving a capital saving of £35 000, and a reduction from 7 to 3 colours, by the same reasoning, would give a capital saving of 38 317 telephones or £196 000. There would also be capital savings in stocks of telephones held in vans (160 000 held at December 1973). How this would reflect back into stocks held in central stores depots (810 600 held at December 1973) is not clear, but some reduction might be expected. Here again, more work has to be done on this, to estimate the effects of variety reduction on other item types.

### CONCLUSIONS

It is evident that there are savings to be made from the exercise of variety control, but it is difficult to quantify these. This brief article has attempted to show the results achieved to date and indicate some possible methods of estimating costs and savings in the purchasing and supply field. These are only part of the story, and some method of estimating the costs and savings effects of variety control in the design and user fields will need to be devised.

### ACKNOWLEDGEMENTS

The author gratefully acknowledges the co-operation given by both Purchasing and Supply Department and regional and area staffs in obtaining the information for this article.

# Regional Notes

## NORTHERN IRELAND

### A New Exchange and Building in 2 Years

On 16 November 1972, Armagh telephone exchange was severely damaged by a bomb for the second time in 2 years.

The bomb completely destroyed working Strowger equipment, installed to give expedient relief following the first bomb attack, and severely damaged TXE2 equipment, which was being installed as a permanent 2400-multiple replacement exchange.

As in the case of the earlier explosion, described in the April 1972 issue of this *Journal*, service was temporarily restored by the use of mobile non-director exchanges.

It was decided to re-establish the permanent TXE2 exchange as quickly as possible in another part of the town, considered to be less vulnerable to further terrorist attacks, and a new site was obtained at the rear of the local police headquarters.

Normal procedures for obtaining a site, providing a building and installing the equipment would take 6-7 years for this size of exchange. In the circumstances, it was decided to set a target for the exchange's final completion of 2-2½ years from the date of the damage. A critical-path programme was initiated, covering both the temporary and permanent restoration work, to plan and monitor the operation.

Since a reduction in building time appeared to offer the best chance of meeting the time scale, it was planned to erect a standard type-K2.2 building, giving top priority to completing the ground floor. A prefabricated hut would then be erected on the ground floor, and this would permit the installation of the exchange equipment to proceed within the hut area concurrently with the erection of the remainder of the permanent building.

Site works were held up for 2 months because of delays encountered in obtaining planning permission, and during this time, the structural steel, ordered in advance, became available. It was then decided to go ahead with the erection of the steel framework, but instead of a prefabricated building, a temporary wooden structure in the form of a cocoon, with a span of 10.82 m, was erected within the framework.

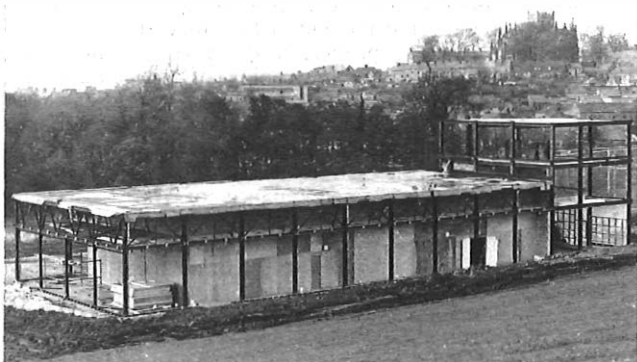

Wooden cocoon within the steel framework, 1 month before equipment installation commenced

The cocoon was formed of studding, clad with exterior plywood on its outer surface and hardboard on the inner surface. It contained temporary welfare facilities, offices and a toilet, and heating was provided by electric fan-heaters. It was so constructed that it could be removed in sections from inside the permanent building without disturbing the exchange equipment.

The temporary building was completed on 10 December 1973, and installation of the equipment commenced on 12 December 1973. The permanent building was completed during August 1974, and the cocoon was removed. The equipment was installed by Plessey Telecommunications Ltd., who agreed to supply and install a 360-erlang, 2400-multiple TXE2 exchange within the reduced time scale, and the exchange was brought into service during December 1974. The

permanent exchange manhole, cable chamber and main distribution frame were provided at the outset, and external cabling operations, together with the installation of transmission and pulse-code-modulation equipment, proceeded concurrently with the exchange-equipment installation. Power equipment has been temporarily sited in the main apparatus room, but it will be moved to its permanent position at a convenient time in the future.

The speedy restoration of the exchange has permitted the connexion of over 300 waiting subscribers, and brought an improved telephone service to Armagh subscribers, who have suffered inconvenience over a considerable period because of the terrorists' action.

The achievement is the result of dedicated efforts by staff from the Northern Ireland Ministry of Finance (Architects' Branch), the Belfast Telephone Area and the Northern Ireland Postal and Telecommunications Board, and was made possible by the co-operation of the Operational Programming Department, Telecommunications Headquarters, and Plessey Telecommunications Ltd.

G. F. ALTON  
E. H. MCDOWELL

## LONDON TELECOMMUNICATIONS REGION

### New International Switching Unit

In connexion with the opening, in October 1974, of the new Mollison international switching unit at Stag Lane, the London Telecommunications Region (LTR) was involved in a great deal of work, much of it urgent.

Although use was made of existing cables wherever possible, it was necessary to provide 9 new cables: 3 main underground and 3 junction cables from Stag Lane itself, with a further 3 junction cables to augment the junction network at strategic points. Some 210 pairs in existing cables had to be cleared for use by pulse-code-modulation (PCM) systems. In addition, 23 tie cables, each of 2000 pairs, were needed to interconnect the repeater station and switching unit at Stag Lane, since these are in separate, non-adjacent buildings.

Eight 12 MHz coaxial-line equipments (CEL 4000 systems) were commissioned by the LTR between Stag Lane and London central switching units. LTR commissioning staff were also involved with a further 5 high-frequency transmission systems linking the London units to provincial centres and, in addition, providing co-operation with External Telecommunications Executive (ETE) staff on through-routed hypergroups.

The circuit-commissioning work, involving a total of some 1200 circuits for the incoming network to the London director area, and about 980 circuits for outgoing routes to Stag Lane, was commenced in early August, and was largely completed in 8 weeks. There was considerable congestion at Stag Lane itself, where the contractor was hurrying to complete his installation, whilst ETE staff had a full programme of testing and lining-up circuits to the provinces. Most of the LTR's work was, therefore, carried out at weekends. Due to the limited access space, it was found that no more than 6 staff could be usefully employed at any one time.

The majority of the circuits were on PCM systems, though some 100 of these were, for the first time in London, extended on audio circuits beyond the PCM terminal. There were about eighty 2-wire audio circuits, which were designed to be amplified in the 4-wire path at Stag Lane to meet the rather stringent overall transmission standards required on international circuits. This called for a special balancing network in the hybrid terminations at Stag Lane, together with the "building-out" of the line attenuation. Due to the urgency of the work, not all the building-out components could be installed in time at some intermediate and terminal exchanges. The circuits were, therefore, lined-up so that they initially operated to acceptable limits, and would improve to the full design standards as the building-out components were added.

K. HOLLOWAY

## SOUTH WESTERN POSTAL REGION

### Specular Reflection

The individual packing of telephone directories is an expensive procedure. Consequently, when the various sections of the Supplies Division were concentrated in their new depot at Swindon, arrangements were made for individually-despatched telephone directories (special orders outside the normal bulk distribution, totalling about 5000/day) to be automatically shrunk-wrapped in polythene.

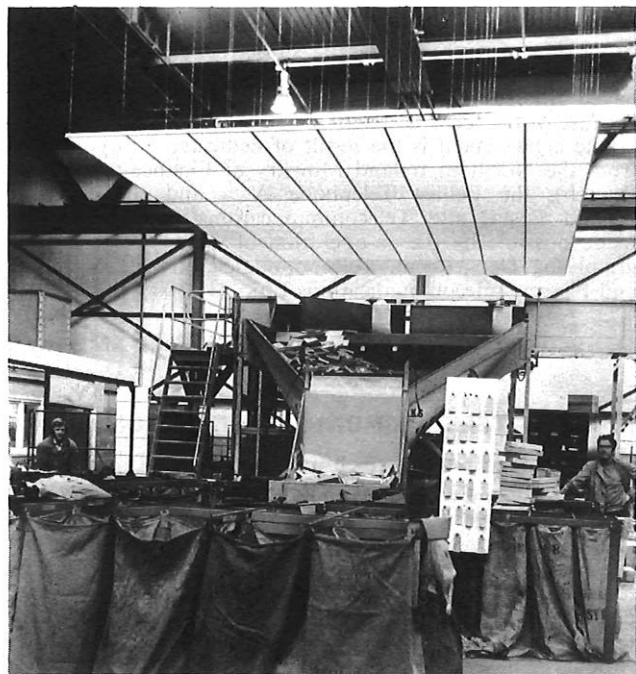

Diffuser suspended over the concentrator's working area

Normally, the sorting of polythene-wrapped items presents no great problem, but at Swindon, where one concentrator is used exclusively for polythene-wrapped directories, staff reported difficulties due to specular reflection from the polythene. This occurred with both natural lighting, through high-level windows on bright summer days, and with artificial lighting.

The problem was overcome by suspending a 7.3 m x 4.9 m louvred diffuser, having a 13 mm cubic mesh, above and in front of the concentrator, as shown in the photograph.

D. C. PRING

## SOUTH EASTERN REGION

### Crossing the Medway

Economic studies and physical experiments by Telecommunications Headquarters (THQ) and Canterbury Telephone Area staff revealed that, in order to improve service and make provision for industrial development, a subaqueous cable-crossing of the River Medway at Aylesford, Kent, would be necessary.

The existing cables are routed around 3 sides of a square, passing over an ancient stone bridge where additions to the existing duct route are impossible.

In order to eliminate waiting time on cable deliveries, the Marine Division of the Network Planning Department, THQ, made available two 80 m lengths of 600/0.63 paper-core-unit-twin armoured cable, which was surplus from a previous operation. The Marine Division also contributed technical advice on the proposed installation.

Protracted wayleave negotiations extended over 4 months with river and port authorities, and public and private bodies. When all negotiations were complete, just prior to the commencement of the work, the Medway Port Authority stipulated that the cables were to be buried to a depth of 1 m in the river bed. Messrs. Mobell Marine of Havant, Hamp-

shire, were quickly contracted to implement this condition by jetting a trench for the cables.

In view of the additional expense now visualized, it was decided to lay two 89 mm diameter rigid PVC ducts in the same trench. Two 80 m lengths of ducting were pre-connected, and the joints sealed. A steel hawser was inserted into each length and tensioned in accordance with the normal preparation procedures for mole-ploughing operations. The 2 ducts were then bound together to form one unit.

The proposed date of installation was, unfortunately, preceded by many days of rain, resulting in the flooding of the surrounding countryside. The river became swollen and rapid, with little difference between the high-water and low-water levels, and only short periods of slack water. Consequently, activity by Messrs. Mobell Marine's divers, in jetting-out the trench, became extremely hazardous.

The cable-laying operation, involving THQ and Canterbury Telephone Area staff, was delayed for one day, and was spread over 16-17 November 1974, when improved conditions allowed the installation to commence.

On the first day, the 2 cables were winched across the Medway and anchored on each side. On the second day, the 2 ducts were successfully laid, and the divers bound the cables and ducts together although, at this stage, they did not lay them entirely in the trench. Messrs. Mobell Marine spent the subsequent days enlarging the trench and placing the cables and ducts into it over the full width of the river. This was followed by a back-fill of bags of cement, and re-turning of the excavated river bed by jetting.

The operation was temporarily abandoned during the weekend 22-24 November, due to Messrs. Mobell Marine's underwater equipment being damaged by a strong tidal flow, and recommenced on 25 November, after repairs to the equipment.

The operation was completed on 28 November, when the river banks were stabilized and re-instated, after which the Medway Port Authority carried out a satisfactory hydrographic survey.

R. H. WILLS

## EASTERN REGION

### Pulse-Code-Modulation Equipment Workshop

The regional pulse-code-modulation (PCM) equipment workshop at Bourne Hill, near Ipswich, completed 3 year's satisfactory operation at the end of December 1974.

It was instigated to provide a PCM equipment service centre, comprising the commissioning of regenerators, the repair of faulty printed-circuit cards, and storage facilities. During the 3 years, the storage facility has been largely discontinued, and the emphasis is now on providing a rapid repair service for printed-circuit cards found faulty during the commissioning and maintenance of PCM systems. Currently, in the Eastern Telecommunications Region (ETR), about 60 printed-circuit cards are repaired each month from commissioning faults, and 80 from maintenance. The repair time for these cards is, typically, less than 10 days, preference being given to maintenance faults.

Two Technical Officers and 2 technicians are employed in the workshop. They repaired nearly 1700 printed-circuit cards during 1973, and commissioned about 1000 regenerators.

Fault-finding is centred on the use of spare multiplex equipment of each manufacturer's type. It has been shown that testing faulty printed-circuit cards as part of a complete multiplex is preferable to faulting individual units on the test bench. When a fault has been cleared, the printed-circuit card is left "on soak" in a separate multiplex equipment.

The information gained from faulting PCM equipment at a single repair centre can be directed to Telecommunications Headquarters, via the appropriate regional service or planning groups. Design weaknesses may then be identified and, after liaison with manufacturers, standards of production may be improved.

The assistance given to commissioning and maintenance groups, during the 3-year period, has enabled the ETR's PCM equipment to be commissioned efficiently and maintained in good order.

J. T. FORD



## SCOTLAND

### Lasting Pride

We have, in the past, been able to tell you of some of the more unusual events in a rather unusual telephone area: Scotland West. There are some 24 group switching centres (GSCs), either existing or in the course of installation, and a total of 341 local exchanges, ranging in size from about a 14 000 multiple down to a handful of connexions; so, it will be appreciated that we have a wide range of equipment, both in vintage and type. Currently, we are in the throes of an intensive exchange-conversion programme and, at the same time, are introducing STD to scores of existing unit automatic exchanges (UAXs).

The past year has seen, perhaps with some nostalgia, the final service of some notable exchange systems in the Area. The following notes record some of the memorable events from our pride of "lasts".

### Maybole UAX7

The last UAX7 in the Area, Maybole, was converted to a TXE2 in June, 1974.

### Brodick CB10

The last CB10 exchange in the Area, Brodick, on the Isle of Arran, was replaced by a Strowger GSC. This installation is also perhaps the last Strowger GSC to be brought into service. Incidentally, this particular CB10 switchboard first saw active service at the Empire Exhibition, held in Glasgow in 1938, and one of the installation team then involved was our present General Manager, Mr. W. T. Warnock. The opening of Brodick GSC, early in October 1974, was accompanied by the simultaneous introduction of STD to 6 of the Isle of Arran's UAXs and small automatic exchanges (SAXs), with the remaining 3 being included by the end of the year.

### Jura and Colonsay Magneto Exchanges

The last 2 magneto exchanges in service in the UK, on the islands of Jura and Colonsay, were converted to SAXs in late October 1974. You may have seen the Jura switchboard and its attendant, Mrs. E. M. McDougall, B.E.M., on the national television news programmes on 16 October. Mrs. McDougall was awarded the British Empire Medal in the 1975 New



Mrs. Effie McDougall at the island of Jura's magneto switchboard

Year's Honours List. The photograph shows Mrs. McDougall at work before the conversion.

These conversions were associated with the conversion of Port Ellen CBS2 to a TXK1 GSC, and the simultaneous introduction of STD to the 5 UAXs and SAXs on the Isle of Islay.

### Tiroran and Pennyghael Country Satellite Exchanges

The last 2 country satellite exchanges in the Area, Tiroran and Pennyghael, were converted to a UAX12 and a UAX13 respectively, during November 1974. These surely must also be among the last country satellite exchanges in the UK.

### Isle of Coll UAX5

The last UAX5 in the UK, on the Isle of Coll, was converted to an SAX during November 1974.

The Tiroran, Pennyghael and Isle of Coll conversions were associated with the conversion of Tobermory CBS2 to a TXK1 GSC, and the introduction of STD to 3 other UAXs and SAXs.

Tobermory itself is unique, in that the main routes to Glasgow and Oban are served by a radio link to the mainland. Also, when all the conversions are complete, 7 out of the 9 local exchanges served by the GSC will be connected via radio systems.

### Newton Stewart CBS2

The only remaining manual exchange in the Area, Newton Stewart CBS2, was converted to a TXK1 GSC in January 1975. Associated with this was the simultaneous introduction of STD to 5 of its dependent UAXs and SAXs, the remaining 5 being scheduled for inclusion later in 1975.

The above record represents only a part of our work, but we are thankful to be able to report that our share of the Highlands and Islands development scheme is now nearing completion. Some direct-labour works remain outstanding, but these will be completed during 1975.

Increasing demand will ensure that our conversion teams do not lose their skills in the coming years; but what of the future? These illustrious pages have done their best to introduce us to the TXE2 and TXE4, but what about the wee brother which will serve our truly rural communities?

S. A. WATT

G. C. DICK

## MIDLANDS POSTAL BOARD

### Increased Parcel-Sorting Capacity at Peterborough

The 2 distribution parcel-sorting machines (PSMs) at Peterborough Parcel-Concentration Office have been under pressure to match peak-traffic requirements, particularly during the autumn and Christmas periods. In order to relieve the problem, the Midlands Postal Board was considering, early in 1974, ways and means of improving the sorting capacity of the distribution PSMs. Several contractors were approached with a view to supplying and installing the Postal Headquarters (PHQ) designed parcel-queuing system known as the mark I dual inject feed (DIF). However, due to the effects of the 3-day week, and material and component shortages, none could guarantee completion by the start of the autumn 1974 peak-traffic period. About this time, the Postal Mechanization and Buildings Department (PMBD), PHQ, issued a report on experiments they had carried out on the mark II DIF, a simplified version of the more expensive mark I DIF, installed at Liverpool Parcel-Concentration Office.

Two such prototype mark II DIFs were on order by PHQ, and it was anticipated that these would be available for live-mail tests by summer 1974. In April 1974, it was decided to install these machines at Peterborough.

The mark II DIF automatically feeds each of 2 sorters per PSM, via their own presentation conveyers, onto a shared static plate. Each sorter works independently of the other, their outputs being controlled by a *code-now* signal on each of the keyboard units. When the minimum parcel-spacing

requirements of the PSM have been satisfied, a TAKE-AWAY roller snatches the next parcel onto the PSM.

The mechanical interface between the existing pre-primary storage conveyer and the DIF was required to supply the sorters with a continuous single layer of parcels, into both or either of the sorters' lanes, and to take account of the space and headroom limitations on the sorters' platform.

The interface installed takes the form of a flat-bedded chute and a short, ridged glacis. The bed of the chute is pivoted, and automatically adopts one of 3 positions, demanded by the mail flow, to direct the stream of parcels into the appropriate lane of the DIF. The control system of the pre-primary storage conveyer was modified to take account of the time limitation imposed by the bed-plate diverter movements and the time taken for the parcels to travel from the pre-primary conveyer to the glacis. The parcels are supplied to the glacis in a slug, the size of which is determined by the glacis' single-layer storage capacity and the rate of sorting.

When the decision to proceed was taken in April, it was considered that the work could be undertaken by British Post Office staff. The chute and glacis were manufactured by the Nottingham Postal Field Force Repair Depot. The wiring and commissioning of the installation were carried out by a team drawn from the Midlands Postal Board, Nottingham Postal Field Force Repair Depot, Peterborough Postal Engineering Field Force, and the PMBD, PHQ.

The work was programmed to commence on 1 August 1974, and to be completed by 2 September 1974. In order to achieve this, it was necessary for as many as 20 people to work long hours in an area of no more than 35 m<sup>2</sup>.

The usual problems caused by long working hours and overcrowding in the working area were encountered, and only the greatest co-operation between the various staffs enabled these problems to be overcome and the plant to be handed over an average of 1 day earlier than scheduled.

L. A. NOKES  
J. V. WEST

## NORTH WEST REGION

### Cable-Tunnel Alarms

To provide a safe and quick method of localizing and identifying the various types of alarms in the Liverpool cable tunnel, a new system of alarm indication is being introduced.

An alarm-indicating panel, consisting of a 2-dimensional silhouetted projection of the tunnel, divided into zones, is being used. ALARM lamps are located on the panel to coincide with the position of their actuating equipment in the cable tunnel.

The lamps give a flashing signal, and are engraved to indicate alarms relating to the presence of fire or gas, flooding, power equipment, ventilation, humidity and security. In

the cases of fire, gas and flooding, an audible *clear-out* signal is automatically given throughout the tunnel.

For routine testing, the ALARM lamps are arranged to glow continuously when tests are applied, and remain glowing until all the alarms have been tested, thus providing a checking facility.

The indicating panel is mounted above a continuously-staffed test-desk position, on the face of which are located zone pilot ALARM lamps, together with the associated receiving-attention and control keys.

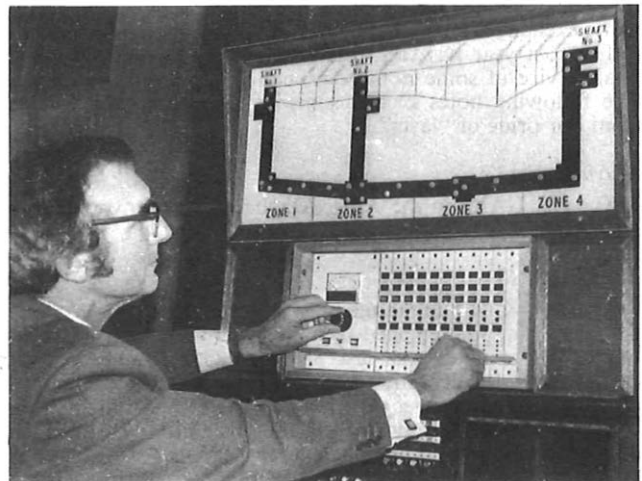

Alarm-indicating and gas-monitoring panels  
(By courtesy of Becorit (Great Britain) Ltd.)

Associated with the alarm-indicating panel is a gas-monitoring panel.

The gas-monitoring panel is connected to remote gas-sensing heads, of the catalytic type, designed to detect lighter-than-air and heavier-than-air gases and vapours. The sensing heads are located above and below duct seals, and in enlargements in the tunnel.

The system is calibrated to react to a concentration of gas of 20% of the lower explosive level of methane, giving a preliminary signal to the monitoring panel. A secondary signal is given if the concentration reaches 50% of the lower explosive level.

The concentration of gas may be measured at any time by means of an indicating meter on the monitoring panel.

To provide ease of access to the higher gas-sensing heads when routine testing is being carried out, 10 mm diameter tubing is provided from floor level to each sensing head. The required concentration of methane gas is injected at the lower end of the tube to activate the alarms.

K. DUNCAN

## Book Review

*Experimental Method—A Guide to the Art of Experiment for Students of Science and Engineering.* W. G. Wood and D. G. Martin. Athlone Press. 101 pp. 11 ill. £1.50.

This slim volume is described on the jacket as, "a young experimenters' guide to experimental method," and is aimed at a wide range of students, from those still in school to those beginning post-graduate study. Its authors intend that it shall be a laboratory handbook rather than a library reference work.

The coverage is comprehensive. Starting with the philosophy of experimenting, the text moves on to the keeping of log-books and then to the formulation of objectives. A long section follows on dimensional analysis and the use of models. The remaining chapters deal with apparatus design, the experimental plan, running the test, the treatment of results and, finally, report writing. The brief list of references is adequate in that it mentions most of the recognized authorities on the subject.

The emphasis is on engineering and the physical sciences,

although there is some mention of the statistical designs called for by the less-exact sciences. Examples are given to illustrate key points, and several of the chapters end with useful check-lists of questions. There are a few errors, both of printing, for example, in the Graeco-Latin square of Table 1(c), and of fact (there are tests of randomness despite the claim to the contrary).

More than a quarter of the book is given to treatment of results, and here the work is at its weakest. The approach falls far short of mathematical rigour, but goes beyond the level of a "cook-book." Indeed, the major criticism of the work is that, in trying simultaneously to meet the needs of a variety of potential readers, it succeeds in doing this, completely, for none. However, despite this shortcoming, it should be a worthwhile purchase for many undergraduates, particularly mature students who may not have indulged in experimental work for several years.

R. T. L.

# Associate Section Notes

## Brighton Centre

We have had 2 coach trips in the last quarter. The first was a Sunday visit to the London Wine Festival, followed by a BBC Television recording at the Talk of the Town nightclub, in which were featured the Three Degrees and Kenneth Williams.

Our second trip was to the Whitefriars Glass Company, to see the production of hand-made glass, followed by an evening at the Haymarket Theatre.

Our future outings will embrace the Science Museum, BBC Television studios, and a week in Benidorm.

T. A. L. BROWN

## Cambridge Centre

The 1974-75 session started in October with a trip to London. The afternoon was spent at the Motor Show, and the evening at the BBC Television Centre, watching a recording of the Dick Emery Show.

In November, the Centre enrolled for a 1-day art and craft workshop course at Trylon Ltd., a plastics and glass-fibre manufacturing company. After demonstrations by the staff, the group was let loose in the workshop to produce their own Works of Art. A wide variety of trophies were proudly carried home.

The programme continued with a lecture on radio interference in January, the annual general meeting in February, and a visit to the transit switching centre in Cambridge in March.

P. YOUNG

## Derby Centre

The annual general meeting took place at The White Hart Hotel, Duffield, on 30 April 1974. Fourteen members were present. The following officers and committee members were elected.

*President:* Mr. M. J. Bennett.

*Chairman:* Mr. P. Morton.

*Treasurer:* Mr. M. Eaton.

*Secretary:* Mr. A. R. Hounsell.

*Librarian:* Mr. P. Holland.

*Committee:* Messrs. E. Hollands, P. Giles, G. Morris, D. Palmer, G. Waywell, G. Franks, and K. Bentley.

After the election of the officers, a discussion of some general items took place, including the subjects of future visits and the encouragement of members. Generally, only a hard core of members attend visits and lectures, but our centre is, nonetheless, very active.

I would like to take this opportunity of expressing a vote of thanks to Jim Rice, our retiring secretary, from the members and committee. Jim has been our secretary for 17 years, and his assistance and patience will always be remembered.

Our programme for the 1974-75 session is now well under way. We have visited RAF Coningsby, Lincoln; Bulmer's Cider Works, Hereford; Barfords of Grantham; the Lotus car works, Norwich; and the British Post Office Purchasing and Supply Department's factory at Cwmcarn. In December, we had a social evening, and in February, a film show.

On 15 April 1975, we visit IMI Metals, Birmingham, and on 29 April, we have our annual general meeting. In May, we visit Watnal weather station, Nottingham.

A. R. HOUNSELL

## Dundee Centre

It is with much sadness that I have to report the death of our chairman, Bob Topping, on 15 December. The name of R. L. Topping first appeared in the Centre's minute book in 1952, when he was made secretary, and from 1956 until his death, he was chairman of the Dundee Centre. A more enthusiastic member would be hard to find. With his keen sense of humour and ready turn of phrase to suit any occasion, Bob will be sadly missed; but it is hoped that some of his zest for life will linger on in our midst.

With 2 of our meetings past, one a talk on the Dundee

City Parks Department, and the other a film show, we look forward to talks entitled *The Reform of Local Government*, *Transit Switching and International Dialling* and *Drilling for North Sea Oil*, and a visit to Messrs. Robb Caledon to see cable ships under construction.

With such a programme, we would hope to see more members coming to meetings in 1975.

R. T. LUMSDEN

## Edinburgh Centre

Our 1974-75 session opened on 16 October, when 17 members visited Chrysler (Scotland) Ltd. at Linwood, where we were shown the complete assembling of a car and the way in which it is tested at the end of the assembly line.

In October, the final of the inter-centre quiz competition was held at Stirling, to determine the team to represent Scotland in the National Technical Quiz Competition. The Inverness Centre played a team from East Scotland, consisting of 2 members from each of the Dundee, Stirling and Edinburgh Centres, the teams being linked by landlines between Inverness and Stirling. The winning team was East Scotland.

On 14 November, the chairman of the Scottish Telecommunications Board (STB), Mr. K. C. Grover, gave a talk entitled *Telecommunications Management—From the Chairman of the STB's Point of View*. Mr. Grover outlined the responsibilities and work involved in the running of a telecommunications board. A lively discussion followed when Mr. Grover gave members the opportunity to ask any question they wished about the British Post Office.

In December, 22 members visited the Edinburgh City Police Headquarters, and were shown the recently-opened communications department, with its very modern equipment. We were later shown the art of fingerprinting in the forensic department.

Our first round in the National Technical Quiz Competition took place on 17 December, when we played Oxford, who are representing the Eastern Telecommunications Region (ETR). The match was played via Confravision between Glasgow and London. The question-master in Glasgow was Mr. S. T. Marsh, Deputy Controller, Service Division, STB Headquarters, and the adjudicator was Mr. T. C. Watters, Executive Engineer, also of Service Division. Mr. Watters is the Associate Section Regional Liaison Officer for Scotland. Unfortunately for us, we were beaten by 45 points to 34½ by the ETR, but we wish them every success in the next round. On the form they showed us, we feel they must surely become the national champions of 1975.

M. I. COLLINS

## Glasgow Centre

Our 1974 meetings are now behind us. They included *Manpower—The Asset* by Mr. D. Soutar, our Deputy General Manager; *The Effect on Maintenance of the Latest Maintenance Aids* by Mr. R. S. McDougal, Executive Engineer, Glasgow Telephone Area; and a visit to Standard Telephones and Cables Ltd., East Kilbride. Each, in their own way, proved interesting, enjoyable and informative.

We are sorry to lose the services of our secretary, Roger Stevenson, but wish him every success on his promotion to Assistant Executive Engineer.

The Glasgow Centre takes this opportunity to wish all our friends and colleagues throughout the UK a happy and, we hope, prosperous 1975.

R. I. TOMLINSON

## Guildford Centre

Since the annual general meeting of April 1974, the committee have worked hard to arrange as varied a programme as possible, to encourage the membership to support the Centre.

The programme commenced in May with a visit to British Rail's Eastleigh locomotive works, which was well supported and proved to be a very interesting visit. On 10 September,

after the summer recess, an all-day visit to London was made, including an arranged tour of the Houses of Parliament. During the weekend of 20–22 September, the Centre made its first venture abroad, with a trip to Paris. This was most successful, and was enjoyed by the 51 members and friends of the party, including our General Manager, Mr. Blair, President of the Guildford Centre.

On 3 October, the Guildford team narrowly lost to Portsmouth in the first round of the Tower Trophy Quiz.

The first lecture of the session was presented by Mr. J. Larke, who gave a well-illustrated and interesting talk on the Dutch telephone system.

On 11 October, a party of 20 members visited the Whitbread brewery at Romsey. This was, needless to say, a very popular trip, being so over-subscribed that a draw had to be made.

The Centre has held 2 film shows, on 21 October and 25 November, but support for them was poor.

On 12 November, a very informative and well-supported lecture on modular power plant was presented by Mr. R. Pine, Telecommunications Headquarters (THQ). On 3 December, to complete the 1974 programme, a lecture was given by Mr. H. B. Ridley on the subject of astronomy, entitled *Mariners and Pioneers*, which included the most up-to-date information gained from the recent space probes. We are indeed indebted to Mr. Ridley, as this is the third time he has provided us with an excellent talk.

On 22 January, Mr. Matthey, THQ, gave a lecture on the TXE4 system, and on 12 February, we visited Whitefriars' glassworks and the Firestone Tyre Company Ltd. Other events are planned.

The officers and members of committee are as follows.

*Chairman:* Mr. W. G. D. Holt.

*Secretaries:* Messrs. D. C. Heather, R. Stone and B. Viner.

*Treasurer:* Mr. G. E. Spickett.

*Quiz Secretary:* Mr. P. Moon.

*Film Secretary:* Mr. S. E. Scantlebury.

*Committee:* Messrs. B. Rogers, R. A. Foster, P. W. Williamson, K. Hannah, J. Sherwin and J. Edwards.

R. STONE

### **Stirling Centre**

Our 1974–75 session began in October with a visit to the plastics division of the Carron Company Ltd. of Falkirk. We also had an opportunity to visit their bath-enamelling department and the assembly-line for a *de-luxe* combined gas and electric cooker. Our November meeting was a talk, illustrated by films, on motoring and safety, given by Inspector Fraser from the Traffic Division of the Stirling and Clackmannan Police Force.

In December, 2 parties of 12 members visited the Drambuie Liqueur Company at Kirkliston. The Company did us proud in the true tradition of Bonnie Prince Charlie who, incidentally, introduced this drink to Scotland in 1746. Even after a few glasses at the end of the visit, we were unable to find out what were the secret ingredients used in the distilling of Drambuie.

We have not produced a syllabus for 1975 because of difficulties in arranging visits. We hope, however, to have a talk on the Jointing Machine No. 4, and to visit the Scottish Television studios in Glasgow, and Messrs. Robb Caledon, Dundee, to see the British Post Office's new cable ships.

J. HANNAH

---

## **The Associate Section National Committee Report**

### **National Technical Quiz Competition**

At the time of writing, the National Technical Quiz Competition has reached the semi-final stages. The remaining teams are the South Eastern Region, Wales and The Marches, North West Region, and Eastern Region. The matches so far have been well-contested and enjoyed by all the participants. We look forward to the final on 21 March.

### **Poster Competition**

Last year, the project organizer, Eric Philcox, organized a national poster competition, and we now have a winner and a poster which will eventually be a National Committee poster. The winning entry came from Norwich, and is a fine example of graphic art. A number of high-quality poster designs were submitted, and choosing a winner was a difficult task.

The next project for members to turn their creative abilities to is the design of a new application form for membership of the Associate Section. A second competition is in progress, and we once again look forward to a high quality and, hopefully, a high number of submissions.

### **Midland Region**

It is with great pleasure that I announce and welcome the Midland Region Associate Section's decision to join the National Committee. The Midland Region has had many

decisions to make, and local matters to clear up, before they could join us, but now, with the Midland Region as a member, the National Committee represents all the regions.

This increase in membership has been eagerly awaited by us, and we hope that, with this added support, the National Committee will be able to grow with confidence, and reach out for greater achievements.

### **National News**

The *National News*, our own journal, is still progressing well, but we would always appreciate articles, photographs and advertisements. Contributors should contact our editor, Colin Newton (telephone: 094 34 2361). You can also help just by buying your copy.

### **Acknowledgements**

I would like to thank all officers of the National Committee, delegates, member regions and local centres for their support during the last year. May I also thank the main Institution, and regional and area liaison officers for their continued help and advice. Finally, thanks are due to the Post Office, and all those managers within its structure who make the existence of the Associate Section possible.

I take this opportunity to wish you all a very happy and successful new year.

P. L. HEWLETT  
*National General Secretary*

# Institution of Post Office Electrical Engineers

## Retired Members

The following members, who retired during 1974, have retained their membership of the Institution under rule 11(a).

- G. S. Richardson, 12 Ashdale Grove, Stanmore, Middlesex.  
 Revd. C. Paxton, The Parsonage, Isfield, Uckfield, Sussex.  
 R. E. Wood, 48 Plumpton Gardens, Bradford, Yorkshire.  
 F. Palin, 22 Highfield Close, Pembury, Tunbridge Wells, Kent.  
 F. G. Cummings, 1 The Vale, Feltham, Middlesex.  
 D. Spencer, 51 Old Orchard, Haxby, Yorkshire.  
 H. A. McFarlane, 89 Beaconsfield Place, Aberdeen.  
 T. E. Meredith, 67 Oakfield Road, Shrewsbury, Shropshire.

- E. W. Weaver, C.B.E., 13 Brooklyn Drive, Reading, Berkshire.  
 F. Hayton, 44 Waterford Road, Shoeburyness, Essex.  
 F. Beatson, 199 Yoker Mill Road, Glasgow.  
 J. R. Preece, 32 Dennon Park, Bristol.  
 R. W. White, Shildaig, Nacton, Ipswich, Suffolk.  
 F. C. House, 1 Mana Butts, Tavistock, Devon.  
 F. Kelly, 37 Marcus Avenue, Thorpe Bay, Southend-on-Sea, Essex.  
 W. A. Humphries, 17 Old Manor Close, Bexhill-on-Sea, Sussex.

A. B. WHERRY  
*Secretary*

## Notes and Comments

### Correspondence

Sale,  
 Cheshire.

Dear Sir,

I would like to draw attention to certain features concerning PMBX No. 4 switchboards which I find rather puzzling.

The current standard charges for a 2-position system are as follows.

	Connexion Charge	Annual Rental
Non-Multiplied	£170	£340
Multiplied	£560	£560

However, it is found in practice that 2-position systems are invariably treated as multiplied, and are charged for at the higher rates. I have been informed that this is necessary because the cords are not long enough to reach jacks on adjacent positions. If this is so, it appears rather surprising since, on all previous cord-type switchboards ever used, it has always been possible for an operator to reach all the jacks on an adjacent position—indeed, in the early days, the operators had access to a 10 000-line multiple.

The higher charges above, for multiplied working, can only be due to the extra cost of multiplying the circuits, and it therefore follows that, if this could be avoided, the lower rates could apply. I would mention, in passing, that the extra cost for a multiplied system appears very high.

It would, therefore, be of interest to know why the above system has been adopted. Surely, there cannot be any objection to operators plugging into jacks on an adjacent position; if there is any marginal advantage in having all lines appearing on all positions, the heavy extra cost would not appear to warrant this. If customers were given the option, it is obvious they would opt for the non-multiplied system.

The above factors also have an obvious and important effect on the charges for systems with 3 or more positions. These obviously require a multiplied arrangement, but if this were on alternate positions in lieu of all of them, there should be substantial savings, of the order of the figures quoted above.

In these days, it is essential to make savings where possible, both in the cost to customers and the use of materials and labour. The elimination of the multiple on 2-position systems,

and the reduction of the multiple on 3 or more positions, would assist in this, and it would be of interest to know why this cannot be done.

W. Turner

*Telecommunications Headquarters was invited to comment on the points raised by Mr. Turner, and the reply is reproduced below.*

Telecommunications Marketing Department,  
 Telecommunications Headquarters.

Dear Sir,

Thank you for giving us the opportunity to comment on Mr. Turner's letter about the PMBX No. 4.

As Mr. Turner says, there is indeed a considerable difference in the charges for a non-multiplied and a multiplied PMBX No. 4, a difference that reflects the actual costs of providing and maintaining the 2 types of installation.

The PMBX No. 4 was originally designed to meet the requirements of single-position installations of up to 160 extensions, and multi-position installations where the extensions are multiplied over the suite on a 2-panel-repetition basis. The length of the present cords does, of course, adequately cater for these 2 arrangements.

As Mr. Turner rightly points out, however, these cords are not long enough for customers to be able to benefit fully from the more attractive charges for 2 adjacent non-multiplied positions. To remedy this, a conversion kit has been designed to enable longer cords to be provided where appropriate, and supplies of these are now being arranged.

Irrespective of the tariff differential between the non-multiplied and multiplied arrangements, the most suitable installation will depend on the customer's requirements, the fundamental choices being

- (a) a single position (160 extensions maximum),
- (b) 2 non-multiplied positions (320 extensions maximum), or
- (c) multiplied positions (200 extensions maximum).

However, as readers will appreciate, the provision of a 2-position multiplied arrangement is to be preferred in those cases where a future requirement for a third position is foreseen.

Mr. Turner's point regarding the savings that may be gained by adopting a 4-panel repetition is accepted and, indeed, readers may like to know that our proposals for a re-design of the PMBX No. 4, for multiplied installations, already includes the offer of this as an option.

A. W. Hassal

34 Hamilton Avenue,  
Ilford,  
Essex.

Dear Sir,

In their interesting article on push-button telephones (*POEEJ*, Vol. 67, p. 224, Jan. 1975), Messrs. S. E. Card and D. T. Littlemore write that, apart from a reduction in the time taken to set up a call where a fast-signalling system has been adopted, the main benefit felt by the customer from the provision of a push-button telephone is in the reduction of the manual effort needed to set up a call. They mention that high-calling-rate business users, in particular, welcome the prospect of relief from continually dialling numbers involving many digits.

It seems worthwhile reminding your readers that an important benefit to all customers is the mental one resulting from the ability to transfer all the digits of a wanted number rapidly from, or via, the customer's memory into a digit store within the telecommunications system. The digit information does not have to be correctly remembered, or repeatedly referred to, during many seconds while tiresome actions are being performed at a limited rate and the distracting rotation of a dial finger-plate is being watched.

It is my opinion, after some years of personal experience with push-button telephones, that the favourable reception of the designs which are currently undergoing trial on the public switched-telephone network is due as much to this, and other psychological reasons, as to the reduction in manual effort itself.

Yours faithfully,

J. H. Combridge.

#### Publication of Correspondence

The Board of Editors would like to publish correspondence on engineering, technical or other aspects of articles published in the *Journal*, or on related topics.

Letters of sufficient interest will be published under "Notes and Comments". Correspondents should note that, as it is necessary to send copy to the printer well before publication date, it will only be possible to consider letters for publication in the July issue if they are received before 14 May 1975.

Letters intended for publication should be sent to the Managing Editor, *POEE Journal*, NP 9.3.4, Room S 08A, River Plate House, Finsbury Circus, London, EC2M 7LY.

#### Correction

Some misleading statements were inadvertently included in part 1 of the article *TXX3 Director-Area Local Exchanges using BXB 1112 Crossbar Equipment*, published in the July 1974 issue of the *Journal*.

The second paragraph of the section headed "Link Trunking" on page 69 implies that the arrangement described, of 5 multiselects in the first bank and 10 in the second, is a common arrangement. This is not so, but the arrangement does illustrate the principle involved.

The information given in the last paragraph of the section headed "Group Selection Unit" on pages 69-70 refers to the 1040-outlet group selection unit. The 2080-outlet group selection unit has 280 links, with a traffic-carrying capacity of 200 erlangs. The 520-outlet group selection unit is not generally used by the British Post Office (BPO).

Although the design capacity for low-traffic and high-traffic units is 104 erlangs, as stated in the section headed "Line Selection Unit" on page 70, the BPO currently limits traffic to 90 erlangs and 97 erlangs respectively.

Referring to Fig. 8 on page 71, access to number-unobtainable and changed-number-interception special junctions is also available from the incoming group selection unit.

The 2-out-of-6 code, referred to in the fourth paragraph of the section headed "Line-Unit Markers and Marking Relays" on pages 70-71, is sent from a test register.

The last paragraph of the section headed "Group-Selection-Unit Markers and Marking Relays" on page 72 implies that circuits of a particular route, which is distributed over a number of secondary sections, must occupy the same outlets on each secondary section. This is not so but, for convenience and ease of maintenance, the same outlets of each secondary section are used wherever possible.

#### Subscriber Loops and Services:

#### International Symposium, London, 3-7 May 1976

Following the success of the first International Symposium on Subscriber Loops and Services (ISSLS), held in Ottawa in May 1974, it is planned to hold a second symposium in London, during 3-7 May 1976. The event is being organized by the Institution of Electrical Engineers (IEE) Electronics Division, in association with the Institution of Electrical and Electronic Engineers (IEEE) Communications Society, the IEEE Region 8, and the IEEE (UK and Republic of Ireland Section), with the support of the Institute of Mathematics and its Applications, the Institution of Electronic and Radio Engineers, and the Institution of Mechanical Engineers.

#### Aims

It is the specific aim, once more, of the Symposium's organizers, to provide a forum for the presentation and discussion of topics embracing the subject of local telecommunications. It is hoped to bring together, for debate, people with backgrounds in research, development, planning and service/operations, having a common interest in the many aspects (for example, technical and economic) of the evolution of telecommunications in the local network. The Symposium offers an opportunity to update systems knowledge and renew contacts in this important activity.

#### Scope

It is intended to cover the following topics in the programme:

- (a) Customers' Equipment,
- (b) Local Network Planning and Economics,
- (c) Line Plant Construction (including Mechanical Aids),
- (d) Local Network Performance, Maintenance and Reliability,
- (e) Local Area Management,
- (f) Safety and Safe Working (Design, Construction and Practice),
- (g) Cable Design,
- (h) Electronics in the Local System,
- (i) New Services and Assessment of Future Needs,
- (j) Wideband Facilities (including Video Services),
- (k) Network Evolution,
- (l) Integrated Local Networks, and
- (m) Mobile (Radio) Services and Facilities.

#### Contributions

Offers of contributions are invited of not more than 7 A4-sized pages (294 × 210 mm), which allows for approximately 3500 words of text (or less, if illustrations are included) for consideration for inclusion in the Symposium Programme. Those intending to make an offer should submit a synopsis (300-400 words) to the IEE Conference Department before 25 July 1975. The synopsis should include the main points of the proposed paper.

A selection will be made from these synopses. Development of full papers will then be invited, to reach the IEE by 24 November 1975. A panel of referees will decide final acceptance of the papers and prepare the Symposium Programme.

Offers of contributions from overseas will be particularly welcome.

#### Programme

As in the 1974 Symposium Programme, it is planned to invite authors to give short presentations of their papers (approximately 10 min), in order to allow maximum time for discussion. Authors are requested to bear these arrangements in mind when preparing their contributions.

The working language of the Symposium is English, which will be used for all printed material, presentations and discussion. Simultaneous translation will not be provided.

#### Venue

The Symposium will be held at the Institution of Electrical Engineers, Savoy Place, London WC2.

#### Registration

Registration forms and further programme details will be

made available a few months before the event, and will be sent to all who complete and return the following reply form.

To: IEE Conference Department (ISSLS 1976)  
Savoy Place,  
London WC2R 0BL

Number of programmes/registration forms required .....

Title of contribution offered.....

Name .....

Address .....

(Please complete as appropriate, using block letters.)

### Supplement

For economic reasons, the Supplement to the *POEE Journal* will now be published in 32-page and 16-page sizes for alternate issues, instead of the standard 24 pages hitherto maintained. The first 32-page Supplement is published with this issue.

### Regional Notes and Short Articles

The Board of Editors would like to publish more short articles dealing with current topics related to engineering, or of general interest to engineers in the Post Office.

Brief reports of events of engineering interest will be published under "Regional Notes". Authors should obtain approval for publication of their contributions at General Manager or Regional Controller level.

As a guide, there are about 750 words to a page, allowing for diagrams. Articles and Regional Notes should preferably be illustrated, where possible, by photographs or sketches.

Contributions should be sent to the Managing Editor, *POEE Journal*, NP 9.3.4, Room S 08A, River Plate House, Finsbury Circus, London EC2M 7LY.

### Notes for Authors

Authors are reminded that some notes are available to help them prepare manuscripts of *Journal* articles in a way that will assist in securing uniformity of presentation, simplify the work of the *Journal's* printer and illustrators, and help ensure that authors' wishes are easily interpreted. Any author preparing an article for the *Journal*, who is not already in possession of the notes, is asked to write to the Managing Editor to obtain a copy.

It is emphasized that all contributions to the *Journal*, including those for Regional Notes and Associate Section Notes, must be typed, with double spacing between lines, on one side only of each sheet of paper. Articles, and contributions for Regional Notes, must be approved for publication at General Manager/Head of Division (Controller) level.

Each circuit diagram or sketch should be drawn on a separate sheet of paper; neat sketches are all that are required. Photographs should be clear and sharply focused. Prints should preferably be glossy and should be unmounted, any notes or captions being written on a separate sheet of paper. Good colour prints can be accepted for black-and-white reproduction. Negatives or plates are not needed and should not be supplied.

### Special Issues

Copies of the October 1973 special issue on the 60 MHz transmission system, and the April 1974 issue covering sector switching centres, are still available, price 45p each (including postage and packaging). A reprint, containing all the most important articles published over the years on trunk transit switching, is also available, price 22p.

Orders, by post only, should be addressed to *The Post Office Electrical Engineers' Journal*, 2-12 Gresham Street, London EC2V 7AG. Cheques and postal orders should be made payable to *The POEE Journal* and should be crossed "& Co." British Post Office staff can assist by enclosing a self-addressed label.

---

## Post Office Press Notice

### Communications for Celtic Sea and North Sea Oil Operations

Two new British Post Office (BPO) projects have been announced: the first will provide facilities to aid the search for oil in the British sector of the Celtic Sea, and the second will ensure high-quality communications for gas and oil production platforms in the North Sea.

In a project costing more than £100 000, the BPO is to install 4 new transmitters and receivers, with their associated aerials and terminal equipment, at its North Devon Coast Radio Station near Ilfracombe. The equipment will link oil rigs in the Celtic Sea, and their supporting ships, with the mainland, providing each rig with its own telegraph circuit to its shore office. The rigs will also have access, over a common radio-telephone link, to the public switched-telephone network.

The new equipment at Ilfracombe is due to come into operation in June 1975. Two transmitters and receivers will be used for radio-telephony, and 2 for the telegraph service. In each case, one transmitter-and-receiver combination will provide service, while the other serves as a stand-by. The new equipment complies with new international regulations for maritime communications, which came into operation on 1 January 1975. Drawn up by the International Telecommunications Union, the regulations require all radio equipment used in the maritime frequency bands to be designed for single-sideband operation.

A £1.5M project to link 2 radio stations, which are to serve North Sea oil and gas production platforms, into Britain's telephone and Telex networks, will also bring a greatly improved telephone service for people living in North-East Scotland, the Orkneys and the Shetlands. The BPO has placed orders for equipment for the 2 radio stations, to be set up on South Shetland and near Peterhead.

The station on South Shetland will be linked with Britain's trunk telephone network by a microwave-radio route, capable of carrying almost 1000 telephone channels. The route will run south to the Orkneys, then to the Scottish mainland, and on to Inverness, to join the existing trunk microwave-radio network. In the Shetlands, the link will be extended northwards, by cable, to Lerwick.

The Peterhead station will be linked into the trunk network by a microwave-radio hop to Aberdeen.

The BPO was, originally, planning to augment communications with Scotland's outer islands by about 1980, but, because of the need to provide communications for gas and oil production platforms as quickly as possible, this scheme has been brought forward and expanded. The entire project, which includes the construction of a number of intermediate radio-relay stations, is expected to be completed by early 1977.

Not only will the BPO be able to give the production platform operators the service they require, but regard has also been paid to the needs of the community covered by this project. They, too, will benefit, through a better telephone service.



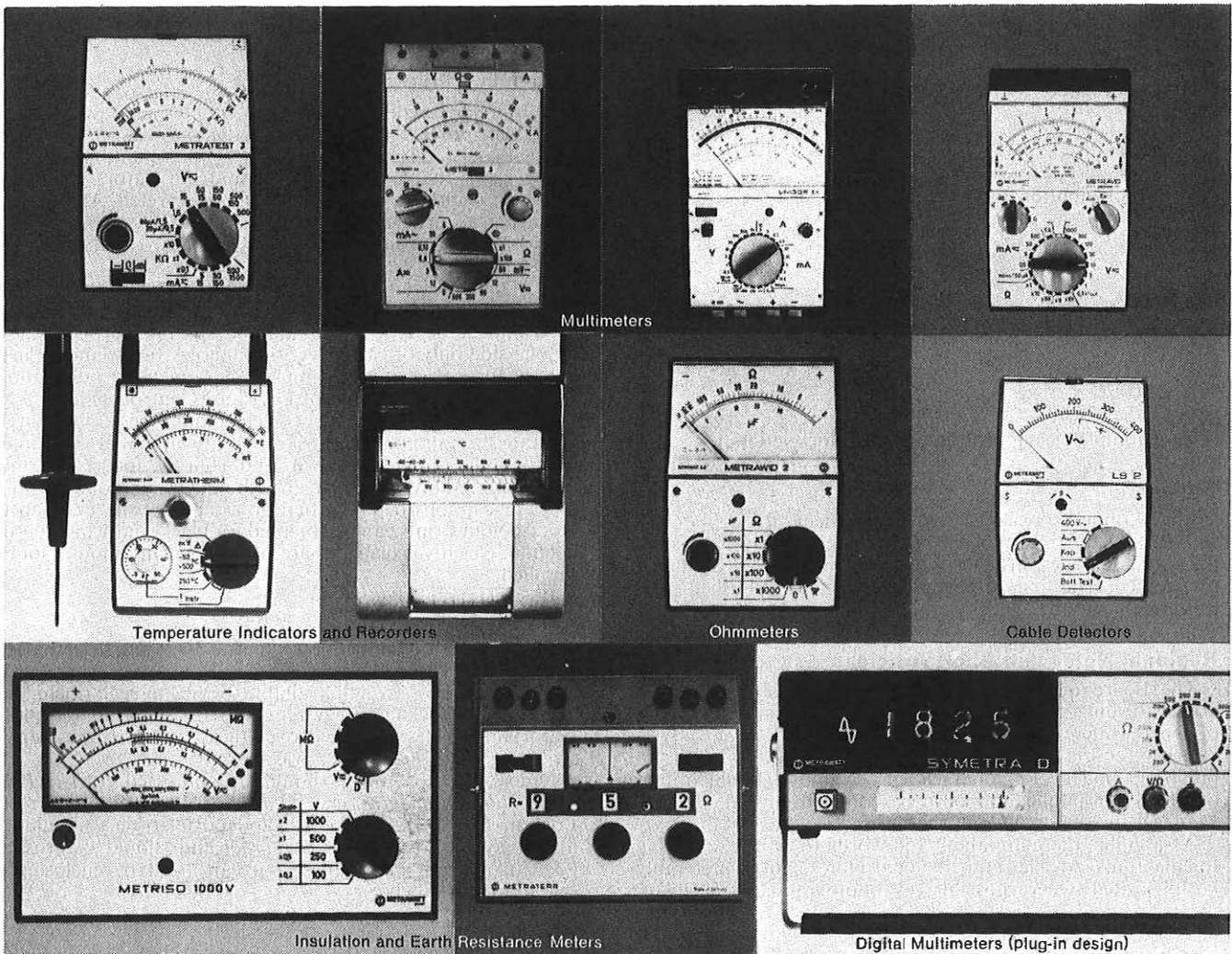

# Europe's widest range of Multimeters and Portable Test Equipment.

Analogue or Digital, battery or mains operated; there's a portable in the Metrawatt range that exactly meets your needs.

Technical data available on request from:-

**Metrawatt (UK) Ltd.**, York House,  
Stevenage Rd., Hitchin, Herts, SG4 9BZ  
Tel: Hitchin (0462) 4112 Telex: 825863

**BBC METRAWATT**  
BROWN BOVERI (UK) Ltd

or any of our main distributors:-

British Central  
Electrical Co Ltd  
London E.C.1.  
Tel: (01) 253 4321

Twickenham.  
Tel: (01) 894 7561

Yeovil.  
Tel: Yeovil 5596

A. & J. Electrics Ltd  
Leeds.  
Tel: Leeds (0532) 605336

Len Rowe Electrical Ltd  
Glamorgan  
Tel: Briton Ferry 813321  
Milford Haven.  
Tel: Milford Haven 4581.

Armos Electrical Co Ltd  
London E.4.  
Tel: (01) 529 3715

Precision Instrument  
Laboratories  
London SE 15  
Tel: (01) 639 0155

Audio Relay Ltd  
Belfast  
Tel: Belfast 24238

Kelly and Shiel Ltd  
Dublin 3  
Tel: Dublin 371621

Risso Electronic Products Ltd  
Buckinghamshire  
Tel: Colnbrook 2171



# PST3

8

**New - generation medium - and high - capacity  
multiplex system (60 to 2700 channels)**

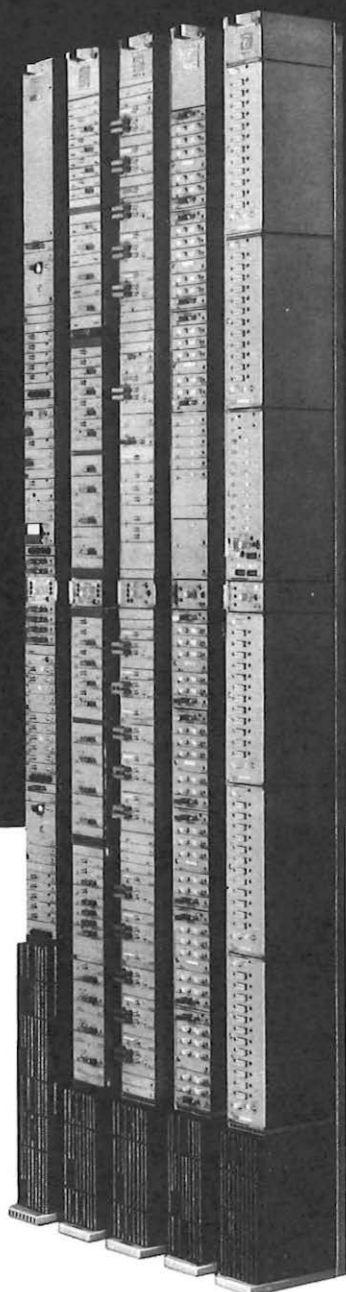

UPT 011/74

**Simple and rational mechanical structure  
Reduced size and power consumption  
Extensive use of advanced technologies  
Very high reliability and flexibility  
Ease of maintenance and expansion  
Performance according to CCITT recommendations  
System complete with all equipment to meet any plant requirement**

*Telettra* VIMERCATE MILANO ITALY

# Now you can give your small subscribers a big-user complex

The GTEX 100 is a brand new electronic branch exchange that opens up—at low cost—a wide range of sophisticated telephone communications for small subscribers.

Now the smaller user, with 25 or 50 telephone extensions, can get all the benefits of a big-user exchange to improve his communications and overall business efficiency.

The GTEX 100 incorporates advanced features like 'Wait on Trunks', 'Call forwarding', 'Ring Back When Free', 'Transit Switching' and many more time-saving programmes, in a compact, free-standing unit the size of a filing cabinet. You can use dial or key instruments, and to extend the capacity to 75 or 100 lines all you need is a second cabinet. And the GTEX 100 works in blissful silence.

The special light-emitting diode (LED) busy/free display gives the operator at-a-glance recognition of line status, including indication of Internal/External Call, Class of Service Identification and, internally, Calling Line Identification. This electronic line

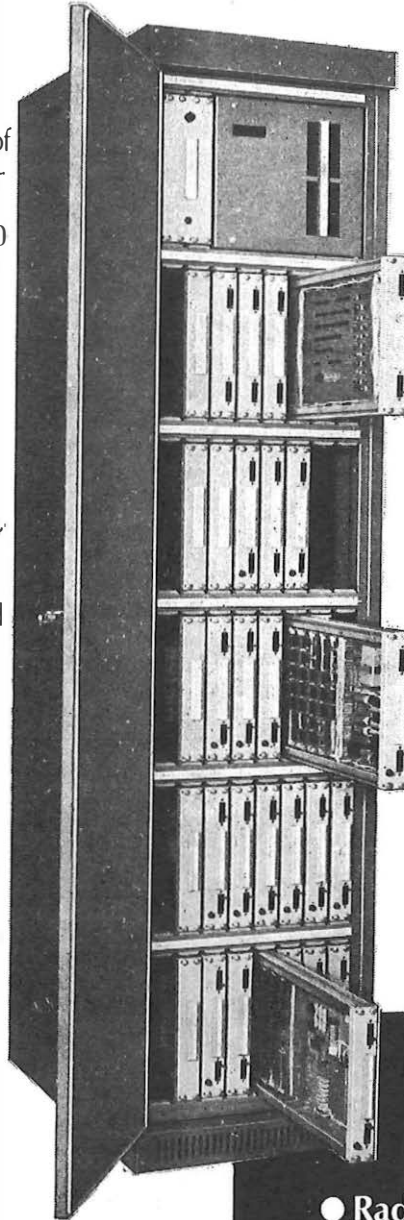

status display also acts as a built-in scanner to diagnose faults. The miniaturised plug-in distribution frame enables the most unskilled user to allocate or re-allocate extension numbers to users, and plug-in slides allow quick replacement of a faulty circuit which can then be checked out later at a central depot.

## **SPACE DIVIDED PRECIOUS METAL SPEECH PATH**

The GTEX 100 PABX was developed by GTE International at its international Switching Development Laboratory at Rochester in Kent. The system uses a space divided precious metal speech path with distributed control, organised round an electronic TDM data highway. The switching matrix has a single stage non-blocking array which allows almost unlimited expansion to cope with heavy traffic, or to provide specialised requirements for heavy trunking. Because of TDM control, only two wires are switched through the matrix. This improves efficiency of crosspoint division and, together with miniaturised,

The following telecommunications products are being supplied by GTE International to U.K. customers:

- Radiolink Systems for TV and Telephony
- Space Communications Equipment
- Echo Suppressors
- Supervisory Equipment utilising MOS LSI Techniques
- FDM Multiplex
- Large Electronic PABX
- Data Modems
- In-Band Signalling Equipment
- House Telephone Systems

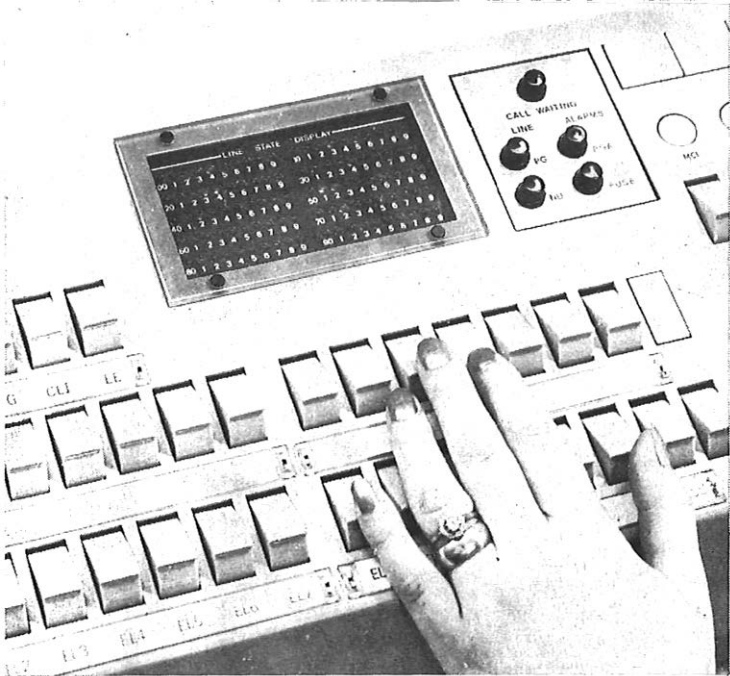

high reliability relays, produces a low-cost yet completely reliable switch. Standardised components streamline stocking and purchasing—for example, there are only six types of miniature relays.

#### **SUBSCRIBER GETS ALL MODERN PABX FEATURES ON A SMALL UNIT**

The GTEX 100 gives subscribers the latest PABX features.

**Wait-on.** If an extension finds all trunk lines busy, he dials a special digit and hangs up. The extension can then continue to receive and make calls in the usual way. But, as soon as a trunk line and the extension are both free, his telephone is automatically rung and the extension connected to that free circuit. This benefit also applies to tie-line working.

**Ring when free.** If an extension dials an internal call and receives a busy tone, he dials a pre-arranged digit to put the call in waiting on the wanted number. He then hangs up. The PABX

continuously monitors the TDM free highway. When the wanted extension is free, the GTEX 100 automatically rings the calling extension and, when it answers, automatically rings the wanted number. A series of numbers in one group can also be handled in the same way.

**Call forwarding.** If an extension wants to arrange for incoming calls to be received on another telephone, he simply dials a given digit into the GTEX 100, followed by the number to which he wants calls transferred. All incoming calls are then automatically routed to the second instrument. This feature can also be used to aid staff location. Dialling the same number of the telephone in the empty office puts the call through to the temporary location or the owner of that extension.

**Extension group search.** By dialling the first number in a group of sequentially numbered extensions, the equipment can be programmed to ring the first free extension in that group.

**Line Lock out.** If an extension remains off-hook without dialling, or after an incomplete PABX number, that line will be 'parked'. This ensures that registers are available for other calls. The line is released from park when the extension goes on-hook.

#### **BIG USER BENEFITS AT SMALL USER COSTS**

These and other advanced features of modern PABX design are often barred to smaller subscribers because of cost. Now with GTEX 100, they too can transform their telephone systems into a highly effective business tool, streamlining operations, saving time and money and improving working conditions.

If you would like to see a system working with the GTEX 100, or require more information on any of our range please write to or 'phone: Chris Cannon, GTE International, Central Way, Feltham, Middlesex. Telephone: 01-890 1455. Telex: 934830. Or, GTE Telecomunicazioni S.p.A., Via Turati 27, 20121 Milan, Italy; GTE International, 1 Stamford Forum, Stamford, Connecticut, USA.

In addition GTE International can offer:

- **Batteryless Keyphones for Decadic Signalling Exchanges**
- **Subscribers Carrier Equipment**
- **Trunk Connected Telephones**
- **Small Electronic PABX (50/100 lines)**
- **Add-on Toll Ticketing Systems for existing PABX**
- **Electronic Main Exchange (including SPC, transportable units, and TSPS)**
- **Electronic Automatic Diallers (MF/decadic signalling) for MAX or PABX testing)**
- **Stackable (highly flexible) FDM Multiplex**
- **24 and 30 Channel PCM and Higher Order Encoders**
- **Radio Link Systems up to 2700 channels capacity**

**GTE INTERNATIONAL**

# ERSKINETECHNOLOGY

## High quality, DC Power Supplies

Competitively priced Erskine DC power supplies. For lead acid or alkaline battery schemes. Used by the U.K. Post Office, the world's leading telecommunications companies, operating on North Sea and Arabian Gulf oil rigs.

A quality engineered range of single and three phase constant potential chargers to 1,000 amps, with solid state thyristor control. Regulation within  $\pm 2\%$  as standard,  $\pm 0.5\%$  to order. Smoothing to telecommunications requirements.

Erskinetechology – standard chargers or custom built power supplies, in chassis or cubicle form.

**ERSKINE**

Erskine Systems Ltd., Scarborough, Yorkshire YO11 3DU. Tel. 0723 883511. Telex 52562.  
A Dale Group Company.

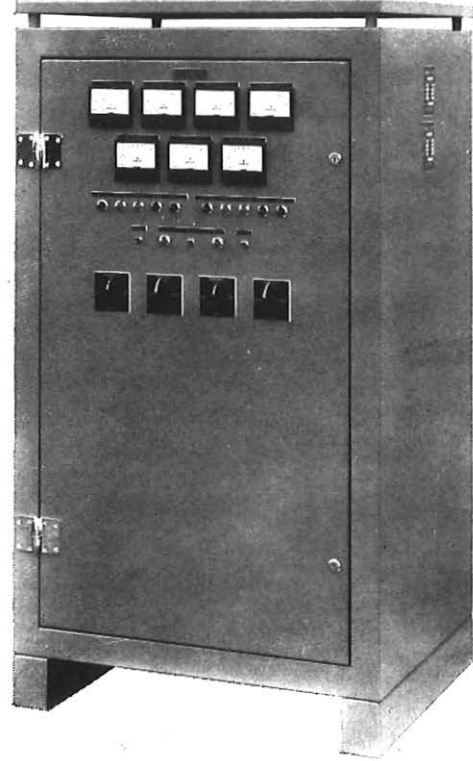

## C.G.L.I. Telecommunication Courses for 1975-76

The following textbooks cover completely or partially the syllabuses of the subjects specified below

### ENGINEERING SCIENCE IN SI UNITS

E. Hughes and C. Hughes

Fourth Impression 339 pages £1.60

221 *Telecom Mechanics Part II Principles*

271 *Telecom Technicians Part I (T1) Engineering Science*

### PRINCIPLES OF ELECTRICITY IN SI UNITS

A. Morley and E. Hughes

Third Edition Third Impression 384 pages £1.60

An ELBS edition of this book is available

221 *Telecom Mechanics Parts I & II Principles*

271 *Telecom Technicians Part I (T2) Principles A*

### ELECTRICAL TECHNOLOGY (SI)

E. Hughes

Fourth Edition Fourth Impression 710 pages £2.50

An ELBS edition of this book is available

271 *Telecom Technicians Principles B & C*

Inspection copies for lecturers are available from The Promotional Services Manager, Longman Group Ltd, Pinnacles, Harlow, Essex CM19 5AA.



## NO COMPRESSOR NEEDED

Send now for details of the powerful, portable Pionjar petrol driven drill and breaker to

**ITT Flygt Pumps Limited,**  
Colwick, Nottingham.

Please send details of the  
Pionjar Rock Drill/Breaker to

NAME \_\_\_\_\_

ADDRESS \_\_\_\_\_

# The new ITT 2300 Teleprinter



## Light on cost. Light on weight. Strong on performance.

This is the new ITT 2300 Teleprinter. Today's supreme teleprinter for telex and private wire usage, and a very significant advance in teleprinter design.

Its main features include:

**Telex Control** Interface and control requirements, for both Telex and Private Wire operation are met by simple strapping options.

**Semi Electronic Design** All signal processing is electronic, using large scale integrated circuit techniques. The answer back coding consists of a printed circuit board which can be plugged into any ITT 2300. Mechanical tasks are limited to print out of page copy, punching, tape reading and keying actions.

So the 2300 is smaller, lighter and quieter.

**Reliability** Micro electronic techniques reduce the number of mechanical parts by two thirds, thus significantly increasing reliability.

**Maintenance** Minimum moving parts and modular construction result in fewer adjustments—maximum accessibility. Routine maintenance

is only necessary every 1000 hours (or one year).

**Versatility** Push a button to select your operational mode. All the usual modes are available. And the 'Tape Prep' mode allows the preparation of a new tape with associated printed copy, while the reader transmits existing information to line. This increases traffic throughput when necessary.

**And** the ITT 2300 is easy to operate—one of the keyboard arrangements has a typewriter layout to minimise training. It's also easy to change paper rolls, tape rolls and the ink roller, too. Tape preparation can be carried out at up to 75 bauds (10 cps), and transmitted to line at 50 or 75 bauds ( $6\frac{2}{3}$  or 10 cps). Operation at 100 bauds ( $13\frac{1}{3}$  cps) is also available. The 2300 conforms to recognised international standards of safety, and is equipped with a time-out facility for private wire usage.

For more details, write to Publicity Department D, ITT Creed Ltd., FREEPOST, Brighton BN1 1ZW. (No stamp required if posted within the U.K.).

ITT Creed Limited **ITT**



### Copyright

The entire contents of this *Journal* are covered by general copyright, and special permission is necessary for reprinting long extracts, but editors are welcome to use not more than one-third of any article, provided that credit is given at the beginning or end, thus: "From *The Post Office Electrical Engineers' Journal*."

The Board of Editors is not responsible for the statements made or the opinions expressed in any of the articles or the correspondence in this *Journal*, unless such statement is made specifically by the Board.

### Subscriptions and Back Numbers

The *Journal* is published quarterly in April, July, October and January, at 30p per copy, 45p per copy including postage and packaging (annual subscription: £1.75; Canada and the USA \$4.50).

The price to British Post Office staff is 21p per copy.

Back numbers will be supplied if available, price 30p (45p including postage and packaging). At present, copies are available of all issues from April 1970 to date, with the exceptions of April 1971 and October 1971 which are now sold out. Copies of the October 1966 issue are also still available.

Orders, by post only, should be addressed to *The Post Office Electrical Engineers' Journal*, 2-12 Gresham Street, London, EC2V 7AG.

Employees of the British Post Office can obtain the *Journal* through local agents.

### Binding

Readers can have their copies bound at a cost of £3.00 including return postage, by sending the complete set of parts, with a remittance to Press Binders Ltd., 4 Iliffe Yard, London, SE17.

### Remittances

Remittances for all items (except binding) should be made payable to "*The POEE Journal*" and should be crossed "& Co."

### Advertisements

All correspondence relating to advertisement space reservations, copy, proofs, etc., should be addressed to the Advertisement Manager, *The Post Office Electrical Engineers' Journal*, 2-12 Gresham Street, London, EC2V 7AG.

### Distribution and Sales

Correspondence relating to the distribution and sale of the *Journal* should be addressed to *The Post Office Electrical Engineers' Journal* (Sales), 2-12 Gresham Street, London, EC2V 7AG.

### Communications

With the exceptions indicated above, all communications should be addressed to the Managing Editor, *The Post Office Electrical Engineers' Journal*, NP 9.3.4, Room S 08A, River Plate House, Finsbury Circus, London, EC2M 7LY.

### Model Answers Books

Books of model answers to certain of the City and Guilds of London Institute examinations in telecommunications are published by the Board of Editors. Details of the books available are given at the end of the Supplement to the *Journal*. Copies of the syllabuses and question papers are not sold by the *Post Office Electrical Engineers' Journal*, but may be purchased from the Department of Technology, City and Guilds of London Institute, 76 Portland Place, London, W1N 4AA.

## INDEX TO ADVERTISERS

	Page
Cotron Electronics Ltd .. .. .	13
Erskine Systems Ltd. .. .. .	11
GEC Telecommunications Ltd. .. .. .	4-6
GTE Information Systems Ltd. .. .. .	9, 10
Herman Smith Ltd. .. .. .	15
E. Hughes .. .. .	11
ITT Creed Ltd. .. .. .	12
ITT Flygt Pumps .. .. .	11
Mettrawatt (UK) Ltd. .. .. .	7
Telephone Cables Ltd. .. .. .	14
Telettra Spa, Milan .. .. .	2, 3, 8
Temperature Ltd. .. .. .	1

## First for all CCTV Systems Cotron RANGE of 'PM' Video Monitors



In 8 sizes (5" to 24") with two cabinet layouts

Designed for broadcast, industrial security and CCTV systems and capable of providing bright clear data display. All solid state silicon circuits. Provides high stability factor so that constant readjustment is unnecessary. Two 'plug in' printed circuit boards make for easy maintenance. Extremely bright pictures can be reproduced by the high resolution and black level clamping features. Unimpaired performance over a very wide range of voltage fluctuations. Available with many optional facilities to meet every application.

GOOD PERFORMANCE—GOOD DELIVERY—KEENLY PRICED  
Write for further details and technical leaflet.

**COTRON ELECTRONICS LIMITED**  
Rockland Works Eagle Street Coventry CV14GJ  
tel (020 3) 21247

# A few of the world's best-known talking drums.



From the depths of Africa's dense jungle-land to the rocky heights of the Americas you'll find them:

Talking drums.

But possibly no drum turns up quite as often around the world as the ubiquitous TCL Cable Drum.

In its own way, that says a lot. That TCL cable, for example, contributes

to telecommunications as far apart as South America and Saudi Arabia.

What it doesn't say is that you can rely on TCL for either a length of telephone cable or the planning, manufacture and installation of a complete telecommunications network.

So we're saying it now. Well, why shouldn't we beat the big drum.

# TCL

Telephone Cables Ltd., Dagenham, England. Tel: 01-592 6611. Cables: Drycore, Dagenham. Telex: 896216.

# The Post Office approves, so will you!

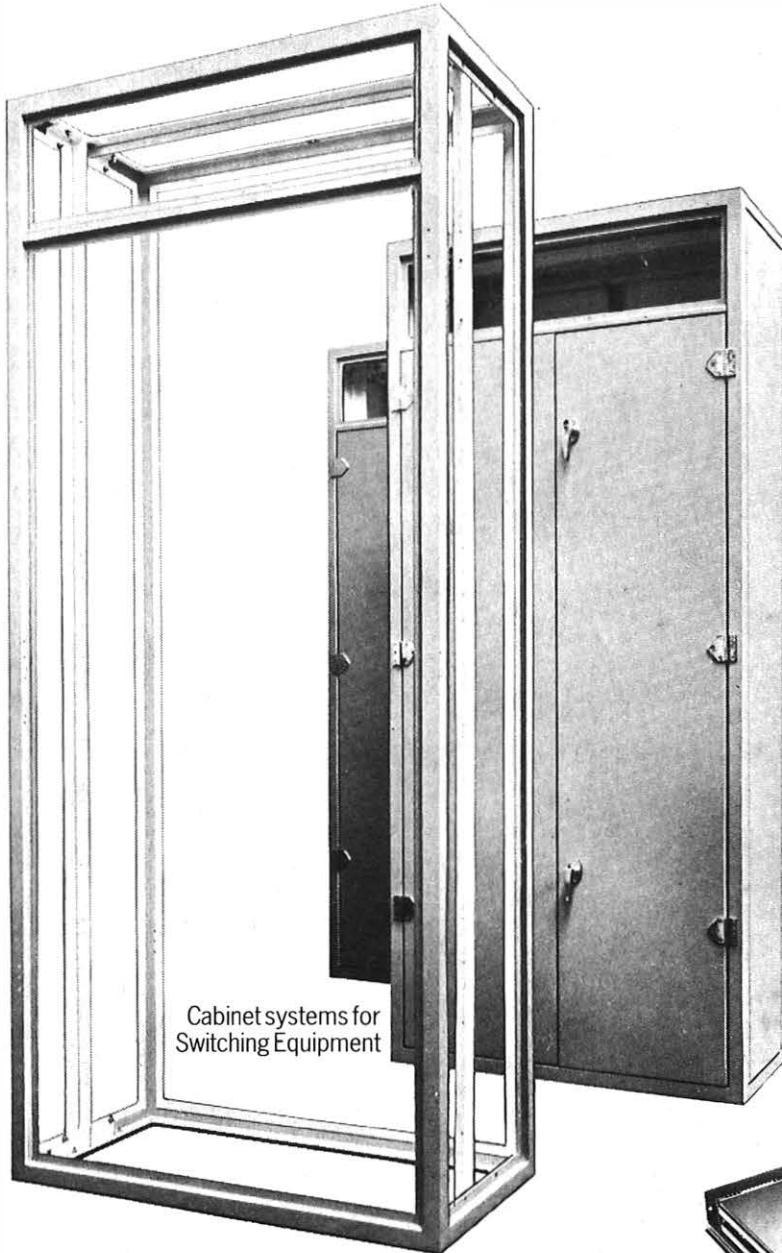

Cabinet systems for  
Switching Equipment

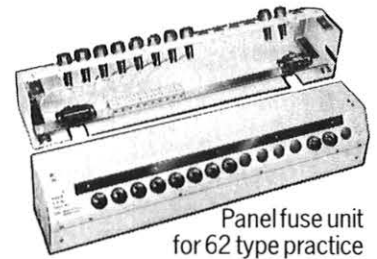

Panel fuse unit  
for 62 type practice

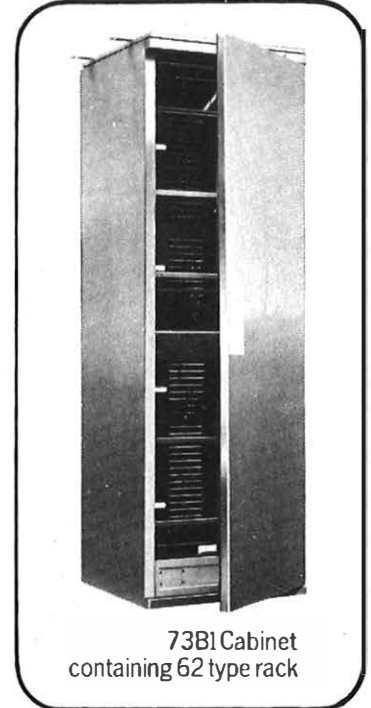

73B1 Cabinet  
containing 62 type rack

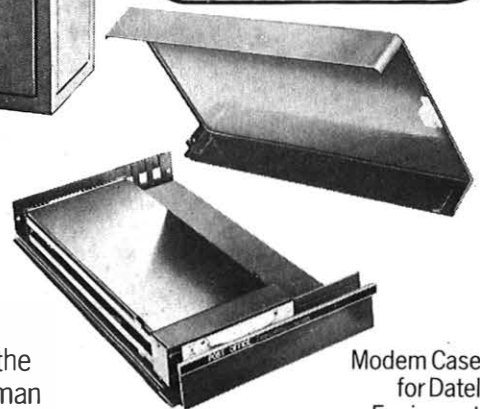

Modern Case  
for Datel  
Equipment

Herman Smith have long held full approval from the Post Office for the production of 62 type equipment. But that's only half the story. Wherever precision electro-mechanical work is involved Herman Smith have all the facilities and all the experience.

From simple sheet pressings to sophisticated cabinets and wired assemblies, we maintain the highest standards, our fully trained QA personnel—ensure your approval to any specification.



Contact Peter Bowen **HERMAN SMITH LIMITED**, Cinder Bank Works, Netherton, Dudley,  
West Midlands. DY2 9AH Telephone Dudley 52791