

# The Post Office Electrical Engineers' Journal

---

**VOL 63 PART 4 / JANUARY 1971**



# THE POST OFFICE ELECTRICAL ENGINEERS' JOURNAL

Vol. 63 PART 4 JANUARY 1971

## Contents

	<i>page</i>
<b>Progress in Postal Engineering—Part 3—Letter Mail—N. C. C. de Jong</b>	203
<b>A New Generation of Auto-Manual Centres for London—K. R. Crooks</b>	212
<b>New Duct for the Protection of Shore-Ends of Submarine Cables—G. C. Backshall</b>	218
<b>The Testing of Broadband Radio-Relay Links—R. A. Moore</b>	220
<b>Programmable Logic—A New Approach to Standardization—C. J. Hughes and W. G. T. Jones</b>	227
<b>A New 20-Line Key-and-Lamp Desk Unit—J. L. A. Lawrence</b>	232
<b>Recent Developments in F.D.M. Transistor Line Systems—J. R. Miller and J. A. L. Gipp</b>	234
<b>Fast Signalling in the U.K. Telephone Network—B. R. Horsfield</b>	242
<b>Automatic Calling and Automatic Answering for Datel Services—A. J. Bott and W. C. Castle</b>	253
<b>Notes and Comments</b>	258
<b>Regional Notes</b>	260
<b>Associate Section Notes</b>	261
<b>Institution of Post Office Electrical Engineers</b>	263
<b>Press Notices</b>	264
<b>Book Reviews</b>	226

Published in April, July, October and January by *The Post Office Electrical Engineers' Journal*,  
2-12 Gresham Street, London, EC2V 7AG

Price 4s. 3d. 6s. (Including Postage and Packing). Orders by post only.

Annual Subscription (post paid): Home and Overseas 24s. (Canada and U.S.A., 3 dollars)

# Wrap up your troubles.....

With the new Ostby and Barton system from UECL. Designed to provide a rational and high-speed solution to the problems of wrapping multi-terminations in the production shop. The AUTO WRAP includes closed-loop numerical control to eliminate wiring errors, speed production and minimise turn-round time.

AUTO WRAP systems can be programmed for point-to-point, dressed or twisted pair terminations. Bits, sleeves and accessories for all wire gauges and terminal configurations are quickly interchanged to tailor the system to alternative applications. For full details contact Ultra Electronics (Components) Limited, Fassetts Road, Loudwater, Bucks. Tel: High Wycombe (0494) 26233

**UECL**

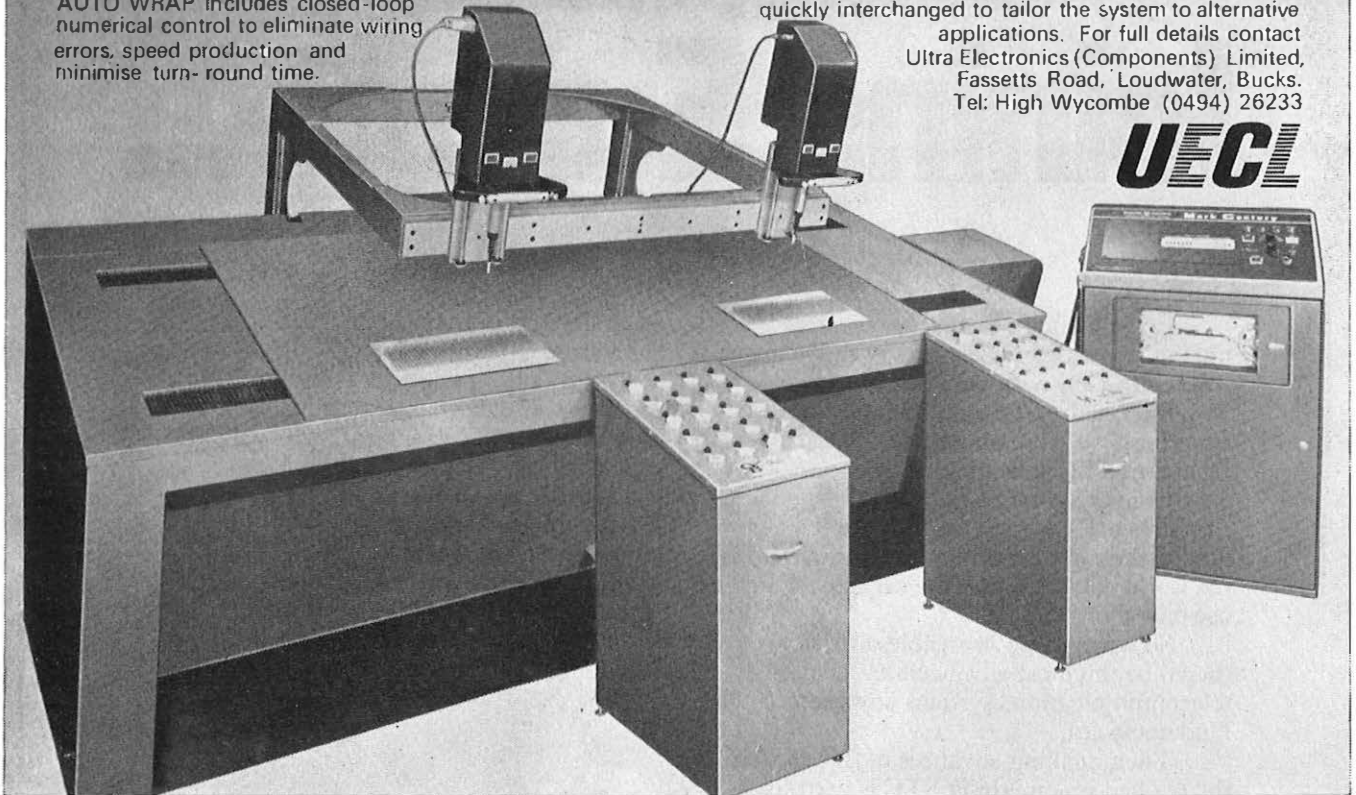

## ask **ASTRALUX** about Relays today!

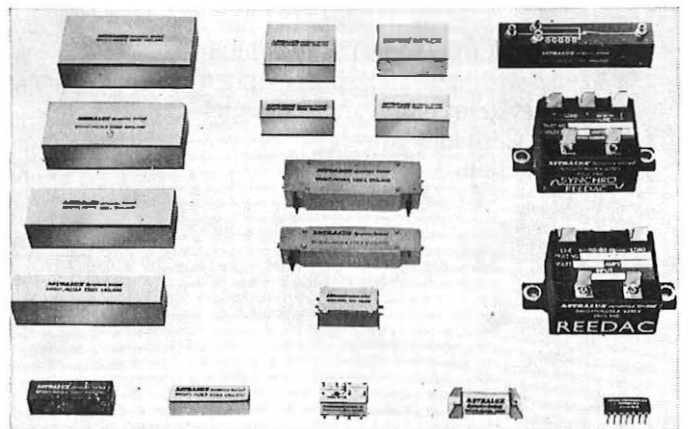

### Because we offer:

- The widest range and latest developments.
- 'Economy' versions when price is all important.
- Models to meet stringent environmental specifications.
- A prototype design service for your special requirements.

Why not find out about the Astralux range of Reed Relays and Solid-State Controllers? We would be pleased to advise on your application and quote for your specific requirement. With our comprehensive range coupled to our experience in Reed Relay and Solid-State Switching Technology we offer a service second to none in this field.

### New from Astralux: The GB811 Series

The first 'family' of 14 pin Dual-In-Line Relays. They are completely compatible with all DIP-IC Devices and have the option of electrostatic screens and/or internal diodes.

Actual Size

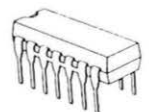

Plus a revolutionary Mercury-Wetted, latching Form C Relay. The GB813C is a bistable, latching Mercury Film Relay. It is a distinct high-reliability device—with a life expectancy of a billion operations. But, of even more importance, it is completely position insensitive. Another unusual feature is its inherent contact memory. The contact always remains in its last position until again activated—without the need of any external assistance, such as a magnet or an energised coil!

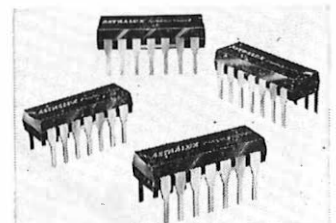

Ask for our Catalogue illustrating the wide range of Circuit-Ready Reed Relays and 'Reedac' Solid-State Switches and Controllers.

**ASTRALUX** dynamics limited

Relay Division, Brightlingsea, Colchester, Essex, England. Tel. Brightlingsea 2571/5

# STC Telecommunications

## Joining Europe...

By new undersea telephone cables linking Britain with Belgium, with Denmark, with Germany, with the Netherlands and with the Channel Islands. And new cables from the Spanish mainland to the Canary Islands and the Balearics.

Each cable can handle 1,840 simultaneous conversations. More than double the capacity of any existing system in the world and ten times the capacity of any in use only five years ago!

So when these new cables are laid they'll be the most advanced undersea telecommunications systems anywhere. Under any sea.

Then, making advances of this sort on the sea bed is something STC is used to. First with 160-circuit, with 360-circuit and with 640-circuit deep water systems.

And by constantly coming up with new ideas incorporated in systems of advanced design STC intends to maintain

its leadership in the field of repeatered submarine cable systems.

Not only providing submarine cables, repeaters, equalisers and terminal equipment, STC also offers an overall capability for systems planning, for project management and for systems implementation anywhere in the world. Standard Telephones and Cables Limited, Submarine Systems Marketing and Projects Division, North Woolwich, London, E.16. England.

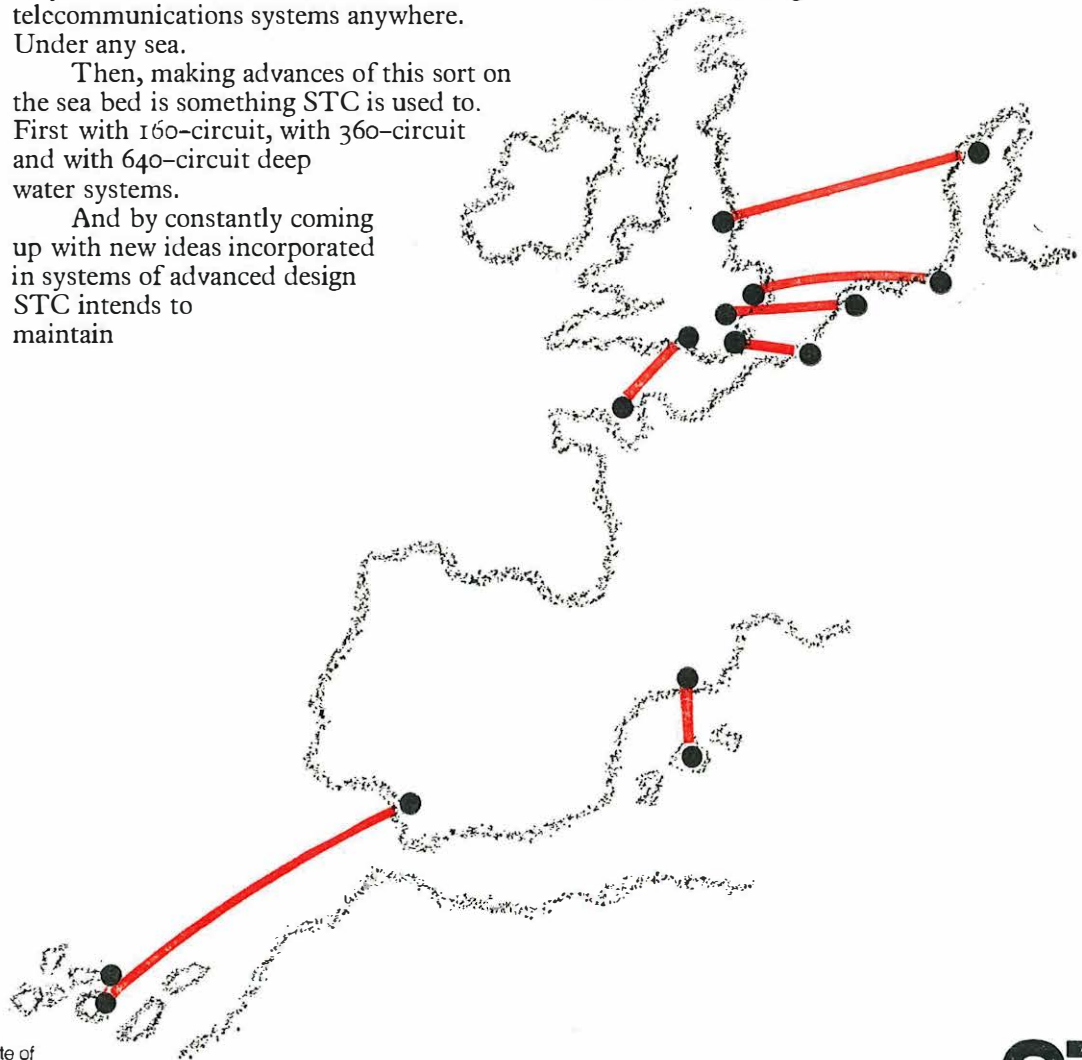

an associate of  
**ITT**

Submarine Systems Group

**STC**

**STC Telecommunications**

## *Treble your underground capacity*

With STC's 12 MHz coaxial cable system type LG12A. This all solid-state system will provide up to 2700 telephone circuits on existing 9.5 mm (0.375 inches) diameter coaxial cables. The repeaters are buried in sealed housings below ground at 4.5 km (2.8 miles) intervals and are power fed over the cable.

The LG12A was the first all solid-state coaxial system of its type to be installed anywhere in Europe, and is currently in service, or on order, for U.K., Austria, Spain, South Africa and Australia.

And for you, advanced technology in the Queen's Award winning LG12A means reliability, economy, dependability and higher capacity.

For more information, write to:-  
Standard Telephones and Cables Limited  
Microwave and Line Division  
Basildon, Essex, England.  
Telex: 99101 (STC Basildon)

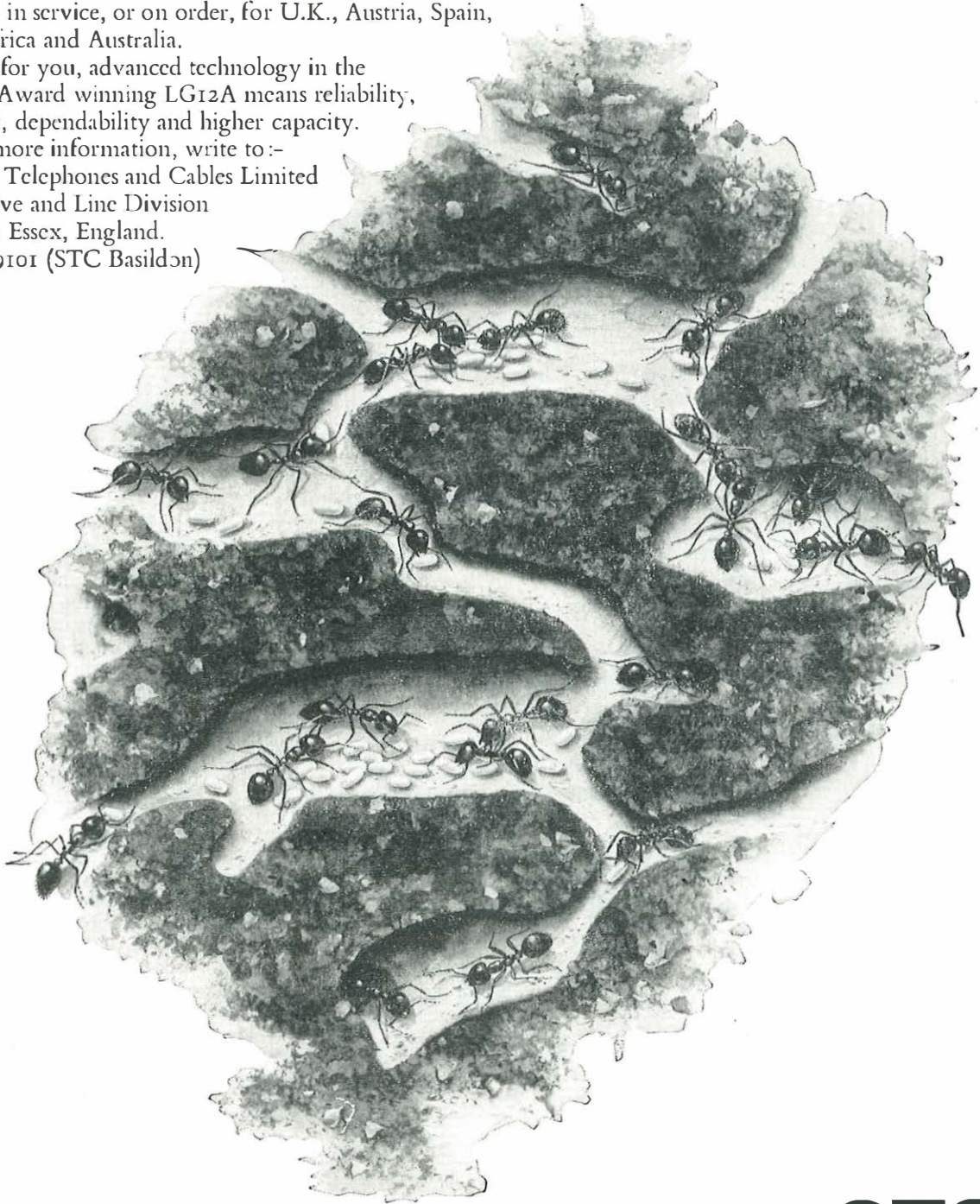

an associate of  
**ITT**

worldwide telecommunications and electronics

**STC**

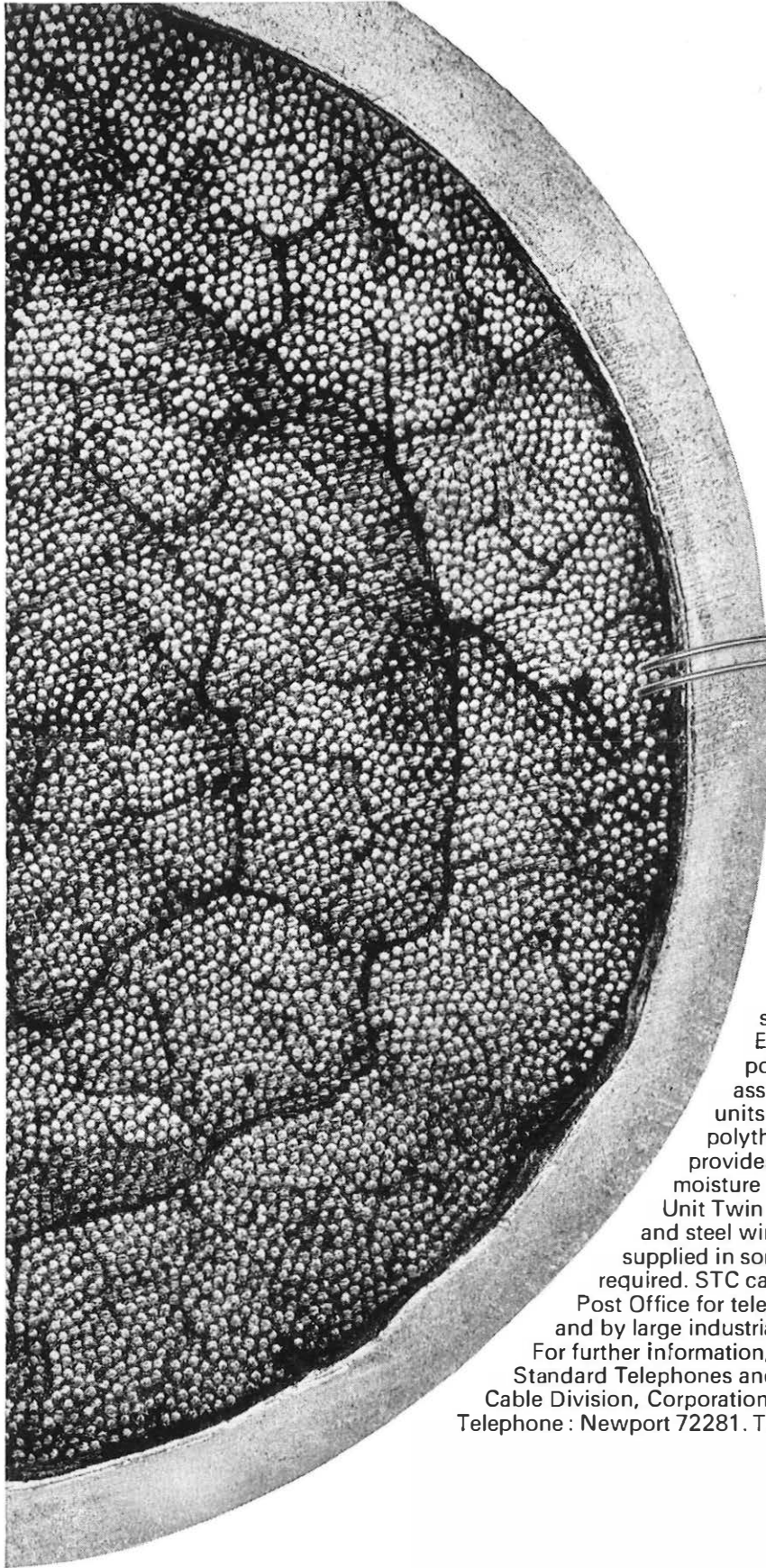

# It's twins!

4,800 pairs of them

This  $2\frac{3}{4}$ " diameter cable is made up of 4,800 pairs of conductors. More than you'll find in any other cable of the same diameter.

It's the largest in the range of STC unit twin exchange cables used in standard Post Office ducts.

Each conductor is insulated with polythene and paired. These pairs are assembled into units, sub units or multiple units of 25. Then the application of a polythene/aluminium sheath overall provides a very effective barrier against moisture and water vapour.

Unit Twin cables are suitable for duct installation and steel wire armoured versions can be supplied in some sizes where direct burial is required. STC cables are widely used by the British Post Office for telephone distribution applications, and by large industrial concerns throughout the world.

For further information, write, 'phone or telex:

Standard Telephones and Cables Limited, Plastic Telephone Cable Division, Corporation Road, Newport, Monmouthshire.

Telephone : Newport 72281. Telex : 49368.

an associate of  
**ITT**

world-wide telecommunications and electronics

**STC**

★  
**The  
STAR galaxy  
expands**

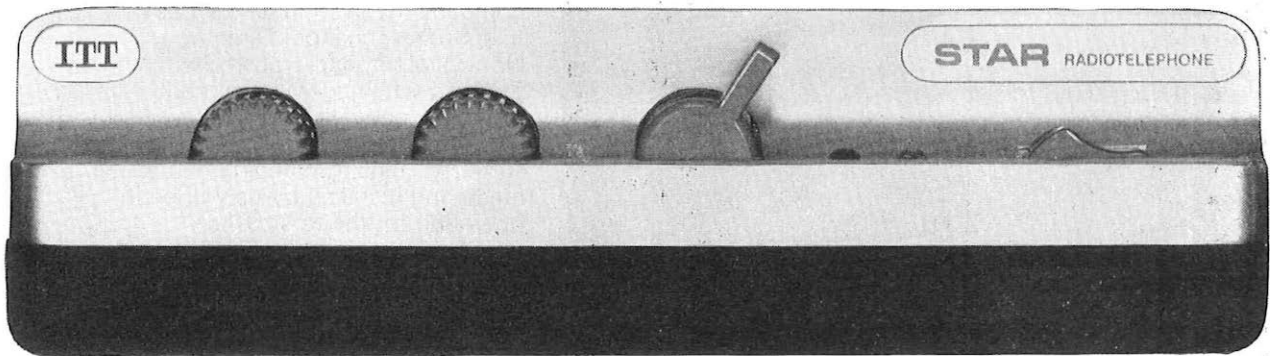

**ITT presents the new  
FM VHF version of the  
STAR Mobile Radiotelephone  
series**

The ultimate in mobile radiotelephone communications – the recently developed STAR FM – is designed expressly for World VHF bands and today it's the best you can buy. It is completely solid state and meets the latest Ministry of Posts and Telecommunications and

world-wide 12.5kHz specifications. It incorporates all the outstanding features that are making the STAR UHF range so successful, combining excellent performance and outstanding speech quality with simplicity of operation and elegant appearance. STAR mobile equipment has no relays

and no moving parts. For more information about the STAR FM or the whole STAR Series post the coupon today. ITT Mobile Communications Ltd., New Southgate, London N.11. Tel: 01-368 1200. Telex: 261912.

Attach your letterheading to this panel:  
Please send me full details of your  
STAR MOBILE FM VHF RADIOTELEPHONE

Name .....

Position .....



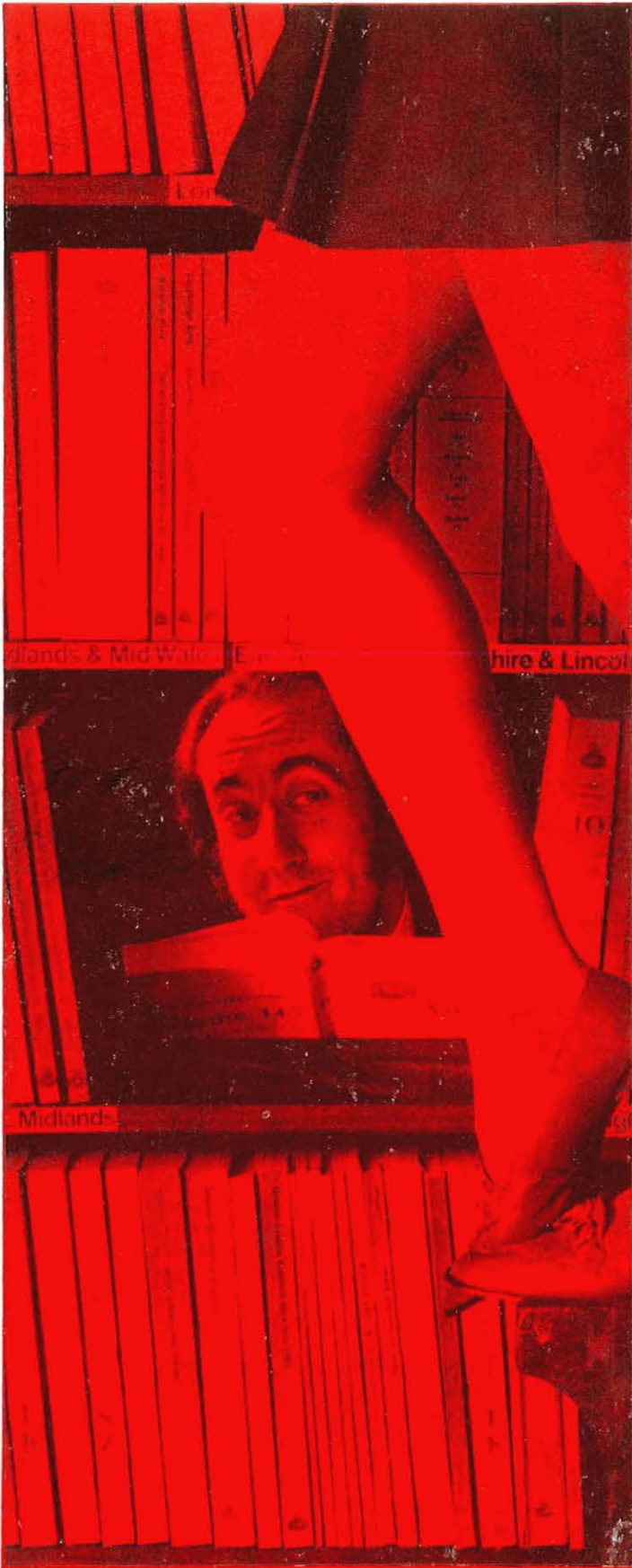

## Some of the books that have been written about us.

It's rather gratifying to see the results of our work in print. But not unusual for STC. A lot more volumes will adorn desks and kiosks around the country by the time we're through. At the moment, we're the only company involved in all 3 types of telephone exchange: Director, Non-Director, and Transit Switching. Transit Switching will eventually provide a new telephone network for the United Kingdom. In a year or so thirty Transit Switching centres all made and installed by us will be in operation for the Post Office Corporation.

Each will have its Group Switching Centres. Which in turn will be responsible for their own smaller, area exchanges.

The very fast signalling provided by Transit Switching will allow more calls through per minute. Fewer delays. Less time wasted, which will be greatly appreciated, because the telephone is the bread and butter of a lot of businesses.

Including ours.

Standard Telephones and Cables Limited, Telephone Switching Group, Oakleigh Road, New Southgate, London N.11, England.

Telephone 01-368 1234. Telex 21917.

an associate of  
**ITT**

worldwide telecommunications and electronics

# STC



**STC Telecommunications**

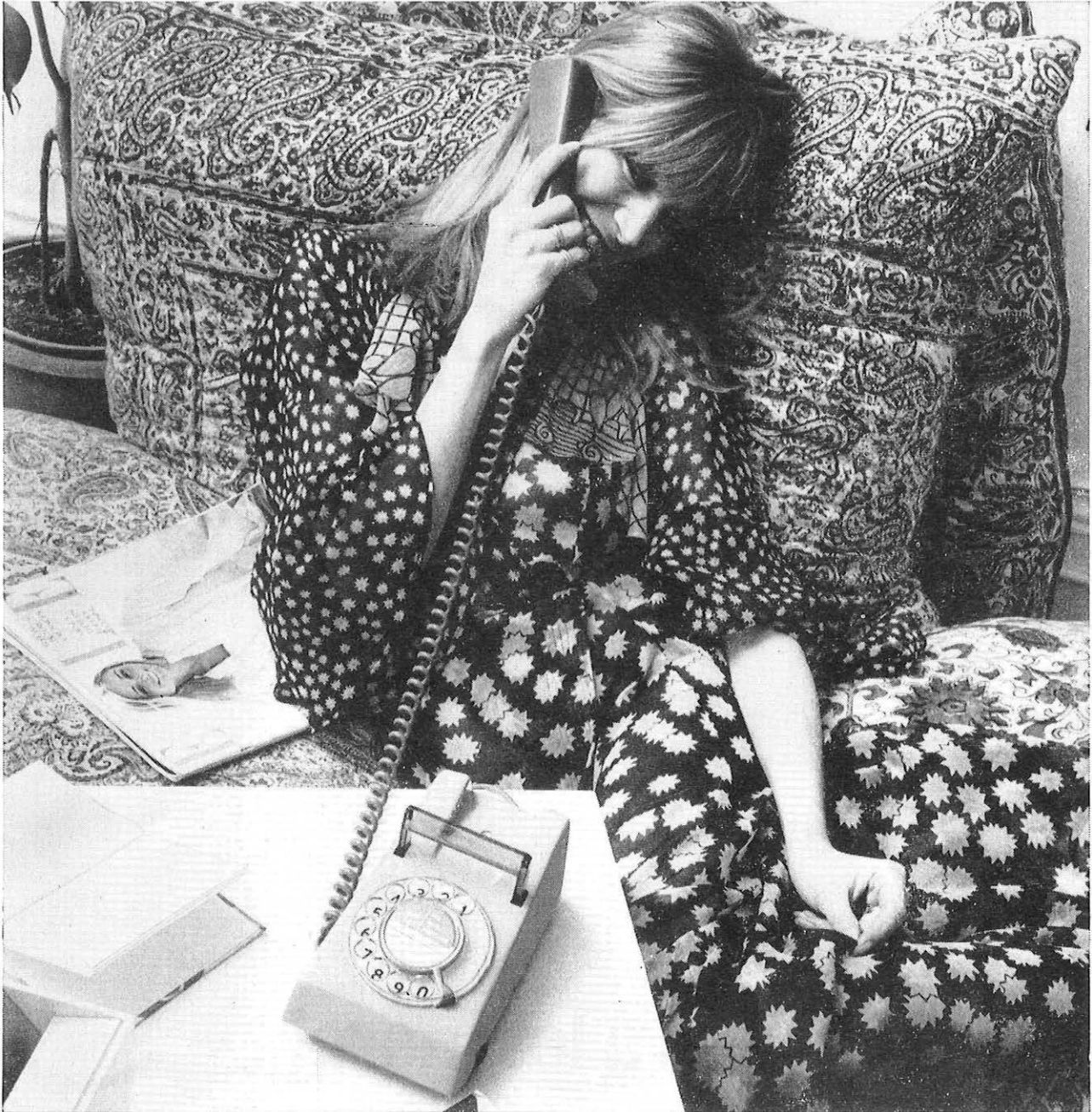

# Our phone is your fortune.

Every Deltaphone your subscribers rent means more profit for you. And Deltaphone has a modern shape and comes in colours to blend with any colour-scheme.

That's why so many people want one.

There is no extra outside plant investment and maintenance is easy.

Let us help you make your fortune.

STC Subscriber Apparatus & Acoustic Division,  
Standard Telephones and Cables Limited,  
Oakleigh Road, New Southgate, London, N.11.

Tel No: 01-368 1234. Telex: 21917

an associate of  
**ITT**

world wide communications & electronics

**STC**

# this new Ferranti edge connector has G.P.O. approval..

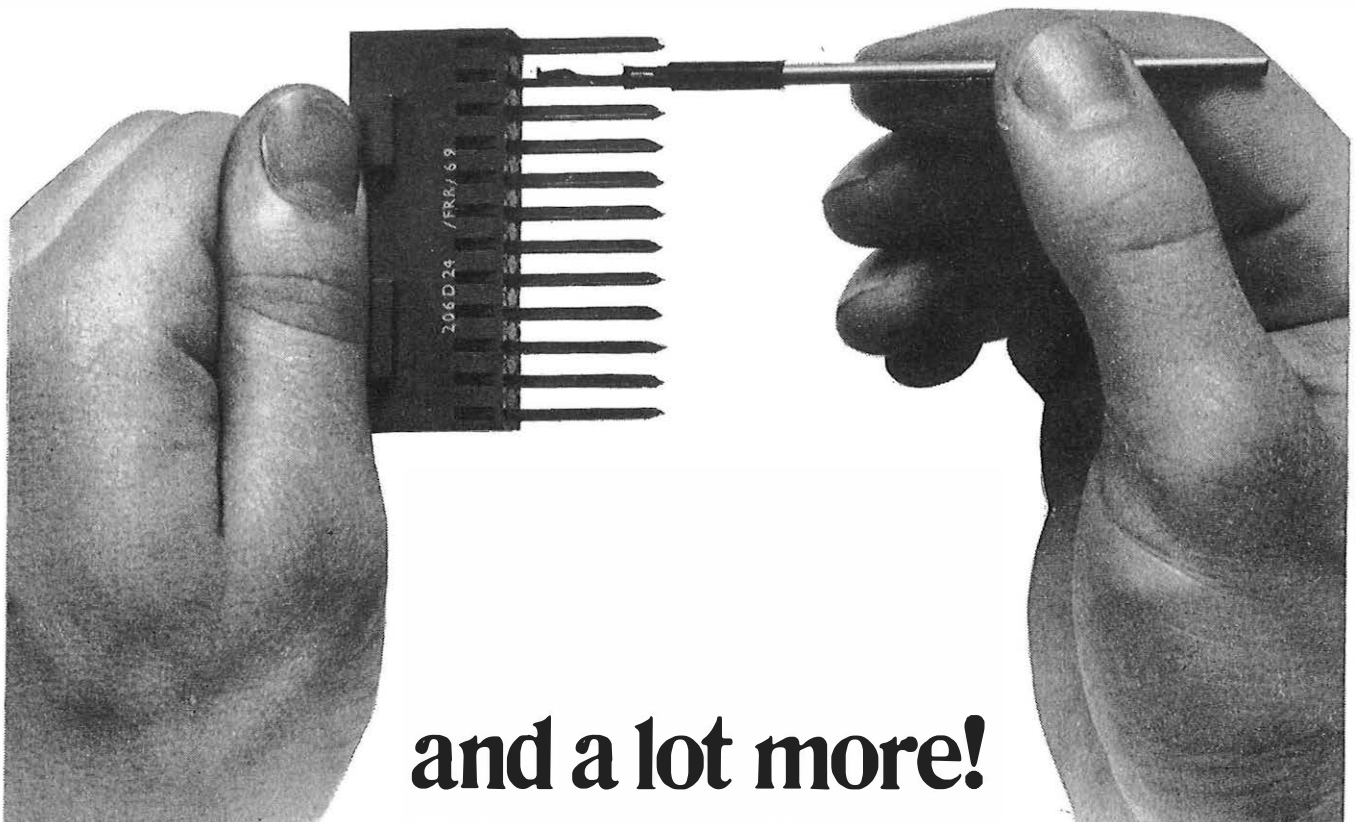

## and a lot more!

The new Ferranti EPP Edge Connector has been designed for electronic telephone exchange equipment, and has Post Office Approval to Specification D2343, Type 206D

And a lot more.

EPP is a new generation of Edge Connectors—offering many new features designed to improve efficiency and reliability.

**Such as** the one-piece construction of the wrapping post and spring contact. This form of construction removes the possible source of unreliability in two part welded constructions.

**Such as** the brand new design which allows each wrapping post/contact unit to be removed from behind the equipment. This operation can be carried out in seconds using a simple extraction tool, without even disturbing the printed-circuit board.

**Such as** the remarkably low insertion force required—only 6 oz maximum per pair of non-bridging contacts.

In addition to these new features, Ferranti EPP Edge Connectors retain many of the successful characteristics of earlier types—including the unique Ferranti 'rolling-leaf' spring contact, with inherent stress-limiting properties and the non-porous hard-gold plating 5 microns thick on the contact area.

12 and 18 pole single-sided 12+12 and 18+18 pole double-sided contacts are available. Pole spacing 0.200 in (5.08mm).

The advanced design of Ferranti EPP Edge Connectors, together with many proved-in-service features, offers equipment manufacturers a connector which is versatile, easy to use and extremely reliable.

Full details available from  
**FERRANTI LTD.,**  
Connector Sales, Dunsinane Avenue,  
Dundee DD2 3PN, Scotland.  
Tel: 0382 89311 Telex: 76166

# FERRANTI

Some rare ingredients go into a telephone cable



The rarest:  
TCL know-how

Open any TCL cable and you'll find some surprisingly ordinary materials doing vital jobs. Paper string to maintain a minimum capacitance and resistance unbalance. Aluminium foil as a moisture barrier. Even plastic buttons to space and insulate coaxial pairs.

In principle and assembly, it looks deceptively simple. It is . . . thanks to TCL expertise.

The largest company in Europe geared to the exclusive production of telecommunication cables, we also design and install complete cable systems throughout the world. And offer a technical advisory service second to none.

Try us, for rare TCL experience every time.



Telephone Cables Ltd., Dagenham, Essex, England. Tel: 01-592 6611. Cables: Drycore Dagenham. Telex: 896216.

*The organisation with 135 years experience*

**ever  
wanted**  
to scale things  
down to your size?  
**with GEC  
open-wire  
systems,  
you can!**

If your longing is for a small-scale carrier telephone network using open-wire line systems, remember that GEC can supply just that—for as few as three high quality speech circuits, in a compact integral unit complete with carrier frequency generating, translating, channel signalling, regulating and line amplifying equipment, and if you wish four duplex VF telegraph channels.

The 3-circuit system (Type 30L3A) has a line output in the band 3.16 to 31.11 kHz, and the 12-circuit system (Type 150L12A), which can be operated over the same pair, has a line output in the band 36 to 143 kHz. In addition, a physical circuit (300 — 2700 Hz) can be operated over the same pair.

The systems comply with CCITT recommendations so that several 3-circuit systems can operate over the same pole route, and several 12-circuit systems can be operated over parallel pairs on the same pole route, in each case with minimum crosstalk.

**3-CIRCUIT - TYPE 30L3A**  
**12-CIRCUIT - TYPE 150L12A**

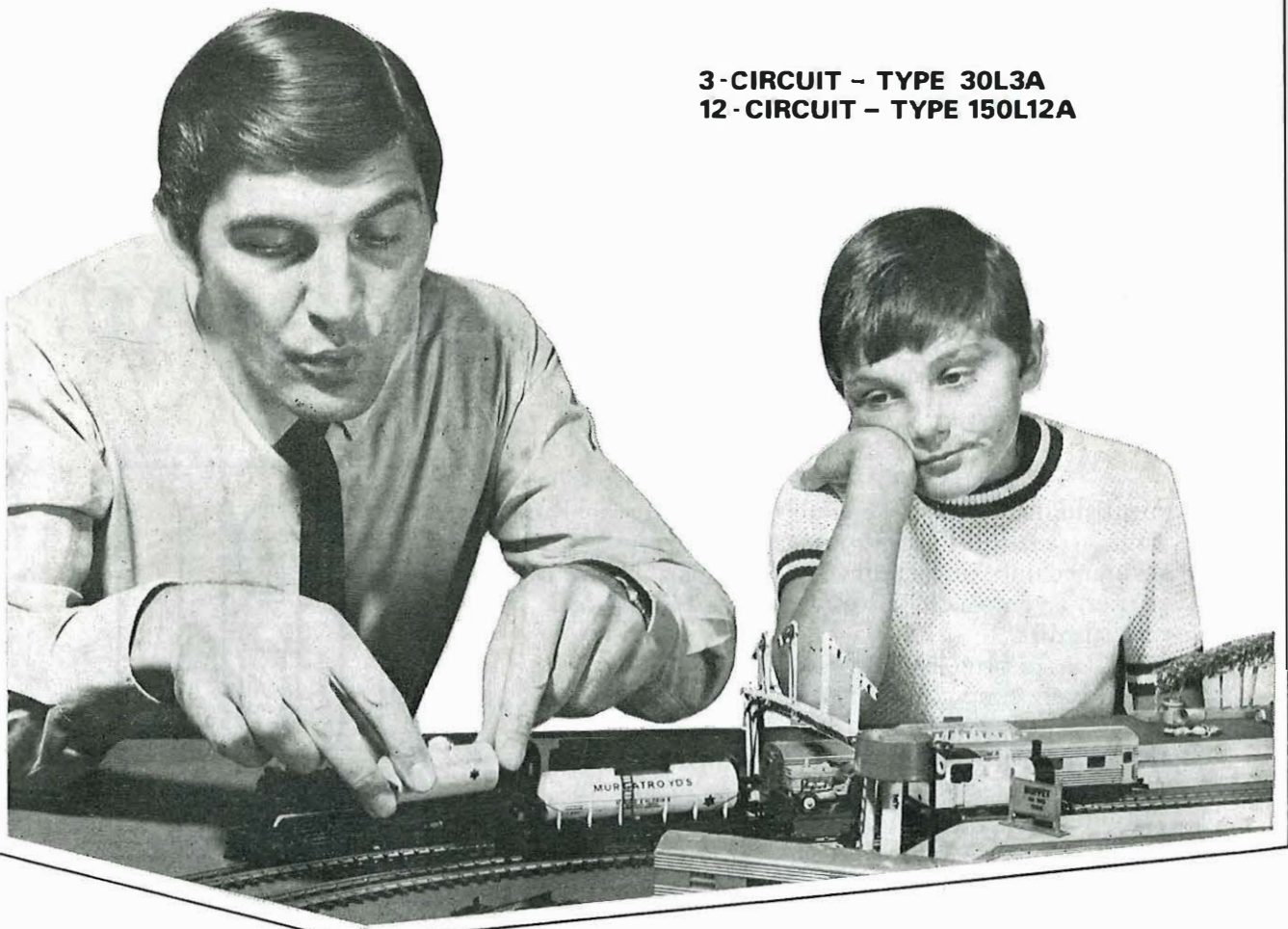

**G.E.C.**

**Takes telecommunications into tomorrow**

GEC-AEI TELECOMMUNICATIONS LTD, OF COVENTRY, ENGLAND.

A Management Company of The General Electric Co. Ltd. of England.

18/46

957  
958  
959  
**960**

## **Good reasons**

for considering the advantages  
of the GEC co-axial cable  
system 4K9B for the relief  
of congestion on  
trunk routes

- \* 960 telephone circuits
- \* 4.4 mm. (0.174 in.) or 9.5 mm. (0.375 in.) coaxial-cables.
- \* Power-fed repeaters at a maximum spacing of 4010 m. (4,400 yd.) for 4.4 mm. cable and 9250 m. (10120 yd.) for 9.5 mm. cable.
- \* Performance to CCITT recommendations.
- \* Proven in operation with over 230 systems covering 6000 route miles being supplied in the U.K. alone.
- \* Underground repeater boxes to house up to six systems.



**G.E.C.**

**Takes telecommunications into tomorrow**

GEC-AEI TELECOMMUNICATIONS LTD, OF COVENTRY, ENGLAND,

A Management Company of The General Electric Co. Ltd. of England.

**Marconi fully automatic message switching systems are economic for small and large telegraph and data relay centres.**

**Marconi is the foremost designer and manufacturer of message switching systems, including multiprogram and high capacity systems.**

# MARS

- needs no human intervention nor the production of paper tape for normal message flow through the relay centre.
- is extremely reliable because of advanced design concepts using microelectronics including dual inline circuits and high-quality components.

- guarantees uninterrupted operation by parallel working of computers and associated equipment.
- programmed computers ensure complete flexibility of message-handling techniques.
- can deal comfortably with mixed traffic speeds, precedence levels and different formats.
- automation reduces manpower requirements to three people for a standard system and fewer for a small system or during lightly loaded periods.
- can be extended and modified without interrupting the service.
- handles simultaneously traffic presented by all incoming channels
- requires no special operating skills.

*Marconi Line Communications Division, specialists in digital transmission, including PCM and error-correcting equipment, part of the total systems capability of Marconi Communication Systems.*



## Marconi Communication Systems

**Complete civil and military static and mobile communication systems**

Message switching  
Digital and data systems  
Microwave and tropo systems  
Mobile radio telephones  
Specialized components

Satellite communications earth stations  
H.F. and l.f. point-to-point systems  
Television and broadcasting stations  
Maritime and naval systems  
Surveys, planning and commissioning

Marconi Communication  
Systems Limited,  
Chelmsford, Essex, England

*A GEC-Marconi Electronics Company*

# NEW from Eddystone

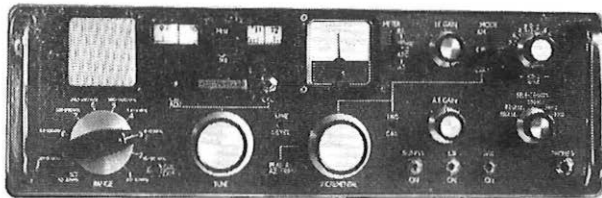

## EC958

10kHz-30MHz. High-stability, self-contained terminal for CW, FSK, AM and SSB. Meets most European Marine Specifications.



## 1830/1

120Hz-30MHz. General-purpose receiver, replacing the well known 830 Series. Operable from mains or 12V battery. CW, AM and SSB facilities.

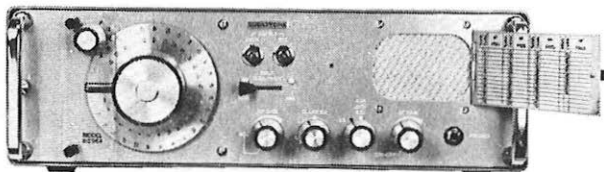

## EC964

Multi-channel spot frequency receiver covering standard Marine bands. Up to 52 channels for AM and USB. Marine approved in Germany and the U.K.

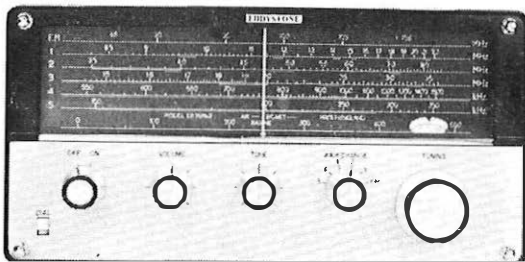

## EB35 Mk. II

High-performance broadcast receiver covering LW, MW, SW and VHF/FM. Operable from mains, external 12/24V supply or self-contained battery pack.

Immediately telephone or telex for full technical data

## Eddystone Radio Limited

Alvechurch Road, Birmingham 31. Tel: 021-475 2231 Telex: 337081

Part of Marconi Communication Systems Limited

# ever wanted

to drop off the line  
without ruining  
everybody  
else's journey?

# with GEC Multiplex, you can!

GEC MULTIPLEX TYPE 4M

GEC Multiplex equipment offers a choice of branching and through filter facilities to meet every need. The aim is to ensure a smooth trouble-free journey for all; the facilities available include branching hybrids, supergroup derivation filters, through group filters and through supergroup filters.



**G.E.C.**

**Takes telecommunications into tomorrow**

GEC-AEI TELECOMMUNICATIONS LTD. OF COVENTRY, ENGLAND.

A Management Company of The General Electric Co. Ltd. of England.

1B/44



## GEC Lincompex

Already proved in practice  
in over 35 countries ...

**can increase  
revenue from your  
long-distance  
HF radio  
circuits, too!**

Over 35 countries already rely on GEC Lincompex to bring the quality of HF radio telephone circuits up to line transmission standards. Now, you, too, can increase your revenue from long-distance HF radio circuits with GEC Lincompex.

Developed from a British Post Office design, it provides:

- Improved signal-to-noise ratio
- Substantial reduction in fading
- Constant loading of radio transmitter
- Quiet 'no-signal' periods to ease the flow of conversation
- Higher traffic handling capability
- Elimination of singing suppressor

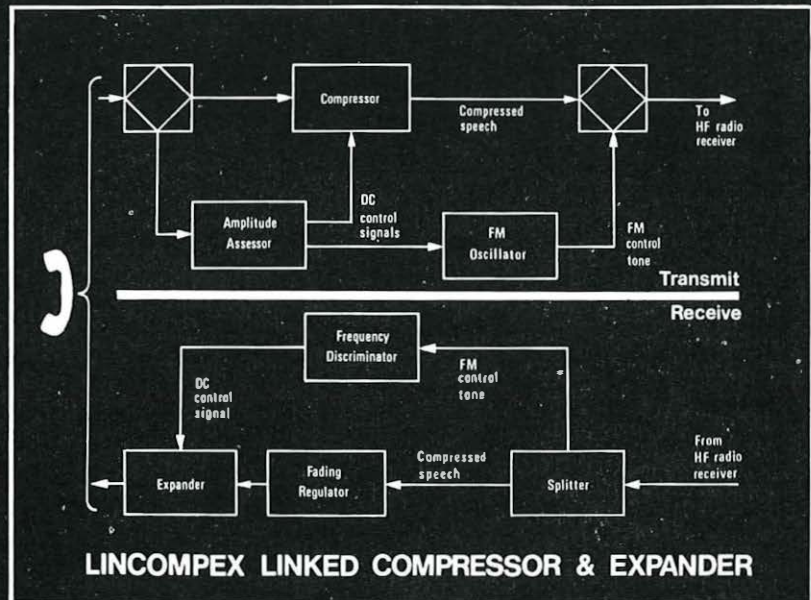
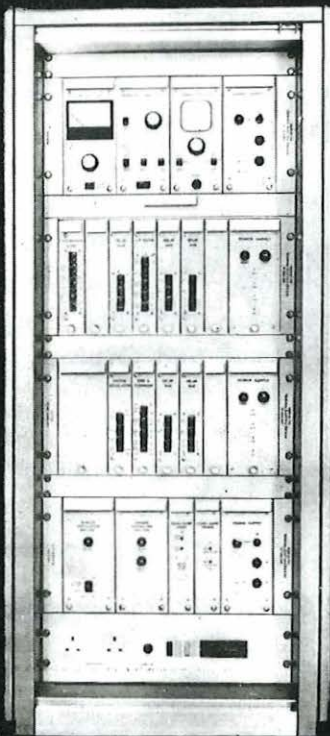

◀ A single-channel '1T' terminal. It comprises: monitor unit; Lincompex transmit unit; Lincompex receive unit; and ringer/signalling & echo-suppressor equipment.



**Takes telecommunications into tomorrow**

GEC-AEI TELECOMMUNICATIONS LTD. OF COVENTRY, ENGLAND.

A Management Company of The General Electric Co. Ltd. of England.

# ENGINEERS!



Send for your **FREE** copy of **'ENGINEERING OPPORTUNITIES'**

**WHAT THIS BOOK WILL TELL YOU!**  
 How to get rapid promotion or a better-paid job · How to put some valuable letters after your name · How to make use of our free Appointments & Advisory Service · How to gain the technical knowledge employers readily pay for · How you can succeed in any branch of Engineering you like—whatever your education or experience.  
**74 PAGES FULL OF EXPERT ADVICE.**

Now ready a brand new edition of this famous book which we would like every ambitious engineer to have—free. We anticipate a tremendous demand so send for your free copy now.  
 'ENGINEERING OPPORTUNITIES' outlines our magnificent range of modern Home Study Courses and is packed with interesting and useful information. Don't miss this enlightening booklet.

**ENSURE YOUR COPY BY POSTING COUPON NOW**

To: BIET Dept. 727D Aldermston Court, Reading RG7 4PF.  
 Tick subject that interests you. Aero Eng.  Automobile  Building   
 Computers  D'manship  Electrical  Electronics  Management   
 Mechanical  Plastics  Production  Surveying  TV & Radio   
 Telecomms.  Work Study  AMIED  AMMI  AMSE   
 C.ENG.  CITY AND GUILDS  GENERAL CERTIFICATE OF EDUCATION

Other subjects \_\_\_\_\_

Please send 'ENGINEERING OPPORTUNITIES' without cost or obligation.

Name \_\_\_\_\_ Age \_\_\_\_\_

Address \_\_\_\_\_

Occupation \_\_\_\_\_

**BRITISH INSTITUTE OF ENGINEERING TECHNOLOGY**

## Should something happen to you, will your dependents need immediate cash?

For only a small outlay each week you guarantee a payment of

# £500

to your nominee immediately on proof of death.

### The Civil Service Provident Society

offers excellent protection at a time when your family needs it most.

The non-profit-making Civil Service Provident Society is for the exclusive benefit of Post Office Employees. Widows and orphans would be eligible for assistance from the Civil Service Widows' and Orphans' Fund if in need.

For more details and quotations for smaller amounts post the coupon

To: The Secretary, Civil Service Provident Society  
 33 Birdhurst Rise, South Croydon  
 Surrey, CR2 7YH

Name .....

Address .....

.....

Please send me particulars without obligation

POJ.1

# ROLL-A-DRUM

**SUPPORTS CABLE DRUMS WITHOUT JACKS**

Are you still using the clumsy, dangerous old methods of hoisting cable drums on jacks? Today scores of up-to-date firms are using the Roll-a Drum. They all report excellent results! The Roll-a-Drum operates swiftly on smooth-running rollers from ground level. Compared with the price of similar-capacity jacks it is a very economical proposition. Either delivered through your wholesaler or supplied direct. Write for leaflet, sent by return.

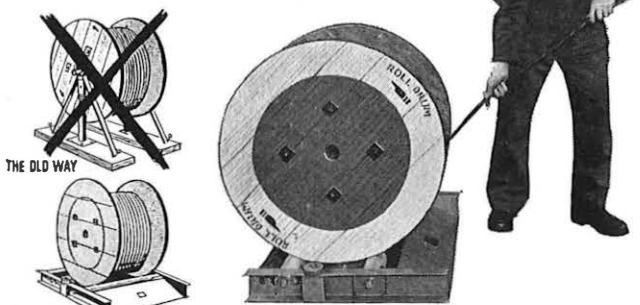

**ERSKINE Laboratories** LIMITED  
 Scarborough Tel: 0723-243

# Progress in Postal Engineering

## Part 3—Letter Mail

N. C. C. de JONG, B.Sc.(ENG.), C.ENG., M.I.C.E., F.I.MECH.E., F.I.E.E.†

U.D.C. 656.88

*This is the final section of a three-part article on Postal Engineering. It surveys the development of letter handling techniques, describes the novel machinery now being adopted for the processing and sorting of letter mail, and outlines new plans for the mechanization and restructuring of the letter-post service.*

### INTRODUCTION

The history of postal communication goes back to biblical times but the birth of the great national and international systems was delayed until 1840 when the universal postal rate was introduced throughout the United Kingdom. Since then the vast expansion of population, education and business has seen the letter traffic increased to such an extent that it is becoming ever more difficult and costly to provide service by the long-established manual methods such as those shown in Fig. 12. These involve 250 million individual handling and



FIG. 12—Manual sorting into 48-box frames

large quantities a cash rebate is given). This preparatory work by our customers saves time and speeds their mail; the items can be streamed in the sorting offices for either machine franking or direct for sorting as appropriate. But this still leaves over 16 million items a day which enter the 1,600 offices as a vast heterogeneous mass of intermixed packets and letters collected from the 100,000 posting boxes. No doubt further developments in the use of postage-meter franking machines will reduce to some extent this quantity of mail, but recent studies suggest that a relatively stable position has been reached in the division between stamped and unstamped items.

sorting operations every 24 hours; a complex human activity which is now reaping increasing benefits from modern technology. Although means of mechanizing the various processes were sought during the 19th century, it was not until the middle of the 20th that engineering reached the stage when economically viable solutions to this very difficult problem became feasible. These have now culminated in a national program for a comprehensive range of machines specially designed to process the huge volume of letter traffic. In consequence, the postal system has been replanned to take full economic advantage of its mechanization.

Thirty-five million items are at present handled daily and about half of these are handed in at Post Offices. Many are received in tidy bundles of letters of uniform size with addresses all facing the same way. (A proportion is partially sorted; for

large quantities a cash rebate is given). This preparatory work by our customers saves time and speeds their mail; the items can be streamed in the sorting offices for either machine franking or direct for sorting as appropriate. But this still leaves over 16 million items a day which enter the 1,600 offices as a vast heterogeneous mass of intermixed packets and letters collected from the 100,000 posting boxes. No doubt further developments in the use of postage-meter franking machines will reduce to some extent this quantity of mail, but recent studies suggest that a relatively stable position has been reached in the division between stamped and unstamped items.

### PREPARATION OF MAIL PRIOR TO SORTING

A considerable proportion of the work carried out in a letter sorting office is concerned with preparing the mail for the principal process of sorting. Packets and large letters must be taken out of the main stream to expedite this, and all other letters arranged for address reading. Then it is necessary to separate the first-class mail from the second class. After this, all stamps have to be cancelled and all items postmarked.

The above processes are described as segregating, facing and cancelling. These are monotonous and man-power consuming tasks (Fig. 13 shows a small part of the operation); hence their automation has received priority throughout the development stages.



FIG. 13—Manual facing table

† Director of Planning and Mechanization, Postal Headquarters.

## Segregation

No single machine can emulate the versatility of the human hand which can be segregating a packet at one moment and facing a first class letter the next. Mechanizing these processes has had to be achieved by a sequential series of operations. However, mail in mass is extremely prone to coagulate and, during the segregating stage in particular, it must be kept in a fluid condition. Many techniques have been used to achieve this fluidity, including the use of air jets, vibrating surfaces and rotating brushes. The most effective technique, the one which originated in Britain, is a slowly rotating and slightly inclined open-ended drum.<sup>2,3,4</sup> After mixed mail from street posting boxes has been loaded into a hopper, a rough-surfaced inclined conveyor smooths the flow into the rotating drum from which the mail is able to escape in two directions as it slides downwards.

A sufficiently thin item can escape by slipping through narrow slits in the wall of the drum; all other items fall out of the lower open end having failed to pass through any slit. (Fig. 14.) (All escape slits are opened wide as they reach top-

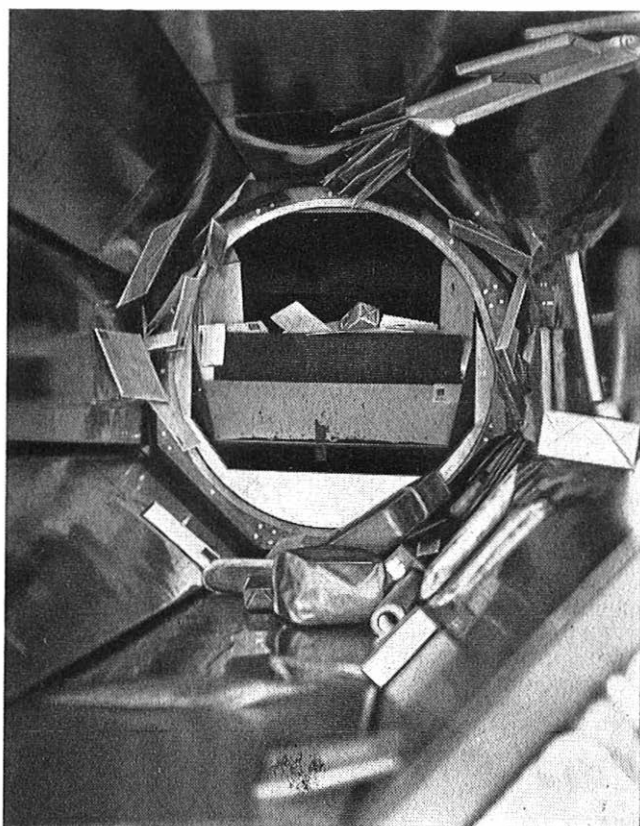

FIG. 14—Automatic Segregator—view from the packet-output end, showing mixed mail being injected from the input conveyor. The drum rotates anticlockwise at 10 rev/min

dead-centre to release items which have wedged.) The drum thus divides the mail into two categories—*thin* items in one and *thick* ones in another. The thin items, which make up about 90 per cent of the total, are then subjected to two further grading stages; the first removes overwide letters, the second the overlong ones. We are now left with the machineable mail which conforms to the international standard range of sizes recommended by the Universal Postal Union, i.e.  $3\frac{1}{2}$  in  $\times$   $5\frac{1}{2}$  in to  $4\frac{3}{4}$  in  $\times$   $9\frac{1}{4}$  in. In the United Kingdom these are known as Post Office Preferred (POP). They form about 80 per cent of the original total or some 13 million per day and are arranged by the machines into neat stacks with all long edges parallel. We have thus segregated the mail into four

streams: (a) thick items, (b) overwide items, (c) overlong items, (d) the standard POP range.

Only the further processing of the last mentioned has so far been completely mechanized.

## Automatic Letter Facing

Although at this point the POP machineable items have been segregated from the residue of unmachineable mail there remains the need for arranging them to face all the same way with the stamps in the top right-hand corner, for separating the first and second classes, and for stamp cancellation and date stamping. The machine<sup>5,6,7</sup> designed for these processes has become known as ALF—the Automatic Letter Facer.

Whereas the segregating processes are effected mechanically, ALF constitutes a marriage of a mechanical conveying system and a complex electronic control system.<sup>8</sup> ALF also differs fundamentally from the segregating machinery in that every item has to be examined individually. The main components are a destacking unit for feeding items one at a time from the stack of segregated letters formed by the earlier machinery; a settling down section to arrange that the letters travel in the most stable position squarely on a long edge; photo-electric scanning units for stamp detection and classification; an inverting unit which turns selected items over whilst in transit; diverters (controlled and selected by the scanners and associated electronics) which determine the routing of the letters in the machine; stamp cancelling units which cancel the stamp and date the items, and lastly, stacking units which put the letters into separate neat packs of first and second class items facing the same way for address reading.

The design of ALF is based upon the assumption that the stamp will appear in the top right-hand corner relative to the address. The letters are arranged to travel through the machine in a direction parallel to their longer edges; hence only four areas need be examined for the presence of a stamp. This simplifies the design of the scanning system. During the early stages in development, scanners were designed to detect stamp characteristics in a similar manner to the eye, that is by location and colour. Although devices on these lines were developed, the techniques available at that time did not give the extreme sensitivity and selectivity required to recognize the different values of stamps if colour alone was used. It would also have been necessary to impose unacceptable constraints upon the artistic designers. As an alternative it was accepted that to provide a reliable technique of differentiating between stamp values, unique unchanging characteristics must be given to first and second class stamps. This has allowed the stamp designer and printer complete freedom to exercise their talents and adopt advanced multi-colour printing techniques. Initially, the distinguishing feature took the form of either one or two conducting graphite lines printed under the gum on the rear of the stamps. These could be detected by applying a potential difference of 1,000 volts between two probes and measuring the resistance. Although stamps of this type were briefly in circulation a much improved technique which gave the stamp a delayed luminescent (phosphorescent) characteristic was discovered and this is the method in use today.

The special phosphorescent organic resin required was developed<sup>9,10</sup> by Post Office chemists at the Dollis Hill Research Station. The specification, amongst other features, called for a material which was non-toxic, and when printed on the surface of a stamp was to be almost invisible. The work was most successful;<sup>11</sup> activators which control the luminescent properties of the resin were produced which have since been used for stamp detection and code marking of letters for automatic sorting. The materials are luminescent after irradiation by an appropriate ultra-violet light source and continue to glow for some appreciable time—a half-life of up to 500 ms. This technique also avoids possible interference from

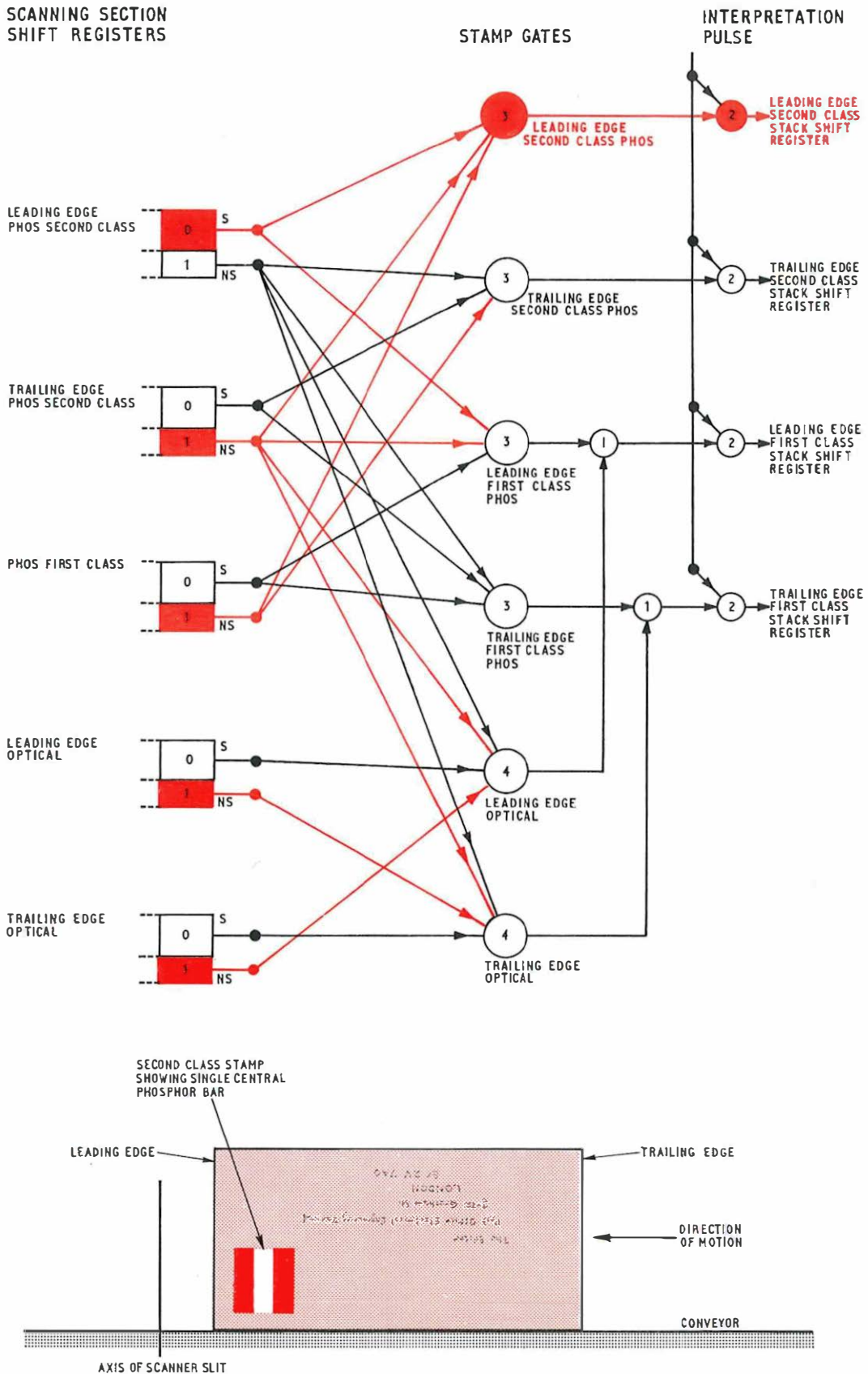

Note 1. The presence of shift register signals NS (indicating No Stamp) is as important for interpretation at the stamp gates as is the presence of the complementary signal S.

Note 2. A first class phosphor (phos) stamp would produce a signal, S, in the first class register and also in either of the two edge-position registers, trailing or leading, thus activating the appropriate first class stack shift register.

Note 3. Two optical signal routes are shown in addition to those using phosphor detection. In the absence of any signal from the phosphor detectors, an optical signal may be accepted.

Note 4. If no logical interpretation results (e.g. no stamp) the letter is conveyed into a reject tray for manual attention.

FIG. 15—Stamp recognition in ALF—the red lines show the presence of signals generated by a second class stamp at the front (leading) edge of the envelope.

optical whiteners in paper, which cause failures if fluorescent resins (i.e. materials which glow only whilst irradiated), are used.

Since only two categories of letter mail are involved (first and second class) the coding of the stamp value can be very simple; it is effected by overprinting the stamp appropriate to the first weight step (4 oz) in the second class with a single centrally-placed vertical bar, and all other stamps with two such bars down the sides. All mail with combinations of stamps therefore appears as first class by virtue of possessing more than one bar. This includes a very small number of second class items which can readily be identified later. This is a fail-safe situation. The marking technique allows a simple design for the detecting units in ALF which comprise four light-tight boxes each housing a photo-multiplier and each having a slit in one face across which the particular corner area ( $1\frac{1}{2}$  in  $\times$  3 in) of each letter slides.

As the items are irradiated immediately prior to scanning, the photo-multiplier detects the glowing lines of the phosphor and the signals, evaluated electronically, are used to control the routing and treatment of each item passing through the machine. The route terminates with the date stamping of each item controlled from lightbeam units, and the separate stacking of the first and second class items. Typical logic circuitry embodying synchronous shift-register stores is shown in Fig. 15. The red lines show the presence of signals generated by a second class stamp at the front (leading) edge of the envelope.

## LETTER SORTING TECHNIQUES

The present, long-established, system for letter sorting and distribution involves circulation<sup>12</sup> between a network of 1,600 offices. Mail reaches its destination through a series of preparation and sorting processes at one or more of the offices along the route. The circulation principle followed is to provide as many divisions at each office as the volume of mail warrants. Similarly, despatches are made as far along the route as can be justified. Although the average number of times a letter is sorted is 3.5 (i.e. either three or four times), it may be as high as seven. The actual figure in each case is determined by the number of boxes on the sorting frame (the standard size has 48 but this varies) and the traffic density along the route. Additionally, the same letter is handled, for various preparation purposes, an average of 3.5 times, thus making up the total of 250,000,000 daily manual processes for the 35,000,000 items.

To speed delivery, Travelling Post Offices<sup>13</sup> (T.P.O.) are also used. These are manual sorting facilities built into railway rolling-stock and are used on the longer routes where travelling time is an appreciable proportion of the total period between collection and delivery. This system enables, for example, mail sorted once in London to reach Scotland fully-sorted for distribution in Scotland. Ideally, a new system would avoid repetitive sorting and handling altogether; it is this repetitive manual work which mechanization seeks to eliminate. Additionally, it can speed up the processes and provide a means of rationalizing mail circulation as described in a later paragraph.

### Early Development of Machine Sorting

The first letter-sorting equipment to be used operationally in the United Kingdom was the Dutch Transorma machine. It was installed in the Brighton Sorting Office in 1935 and was in use until 1969. Although successful as a mechanism it had a number of features unsuitable for conditions in the United Kingdom, the most serious of which was the requirement that the five operators could feed letters only in strict synchronism with the rhythm of the machine. This led to considerable debate as to whether synchronous or asynchronous working was preferable. In Britain, students of the human factor in the man-machine interface were beginning

to reject the former concept. Shortly after the Second World War, therefore, when the development of postal machinery in the United Kingdom commenced in earnest, a six-operator sorting machine was designed to allow each operator freedom to work at the rate he chose. Another feature introduced for the first time was that the mail was automatically presented to his view and transported, under instruction from a keyboard, to any one of 120 selection-boxes. Invaluable experience gained in the course of this development demonstrated that for smooth and rapid operation the operator should be able to view two consecutive letters in the stream automatically presented to him. This enables him to scan the address of the on-coming letter whilst his fingers are keying information referring to the item previously read; his mental processes can then overlap his slower muscular responses. With this technique, the instantaneous maximum rate of working approaches two per second for a skilled operator and the machines must respond to this. Otherwise, when dealing with repetitions or simple code sequences, he can be frustrated.

Work on the six-position machine indicated that the complex equipment required to inter-leave the work flowing from six operators was very costly. Additionally, the large machine which resulted introduced difficulties for office layouts and required on-site assembly. These findings led to the development<sup>14</sup> of a single-position letter sorting machine (S.P.L.S.M.) having 144 boxes. Twenty of these machines,<sup>15</sup> having a maximum speed of 7,200 letters per minute, were constructed in the 1950s and continue to give good service in a number of offices in the United Kingdom. These machines can be used, for instance, for sorting outward foreign letters which, at present, must not be code-marked. The latest model<sup>16</sup> available incorporates integrated-circuit control and although it is designed for use initially by an operator, it can be readily converted for automatic code-mark or O.C.R. (optical character recognition) working at a later date.

There are two main advantages with these machines over manual operation; there is a potential increase of at least 2 : 1 in the speed at which one human being can sort and the number of selections made is increased by 3 : 1, thus substantially reducing the number of subsequent sorts. The operator is seated comfortably and the letters are passed to the appropriate box with virtually no manual effort; thus with mechanisms which respond at a fast rate, optimum conditions are produced.

The smaller machines were eminently successful when employed in sorting mail for distant places (outward sorting) as the geographical knowledge demanded from operators was well within their memory capabilities and exceptionally high operating speeds, approaching 100 items per minute, could be reached.

However, when used for the inward sorting required for delivery, where the operator has to remember the grouping of the streets (or part of streets) allocated to each delivery postman, the memory task in large towns proved too great to permit accurate and rapid operation. To overcome this problem the keyboard, which up to this point had 24 keys (12 keys being operated by each hand) was replaced by a typewriter layout. The operator no longer had a memory task to perform but he copy-keyed the first letters of the post-town name, followed by the last two when outward sorting. For inward sorting he copied the first two, the last two and the initial of the type of thoroughfare (e.g. BRISTOL = BRIOI; GRESHAM STREET = GRAMS). This method of translation by the human operator of address information is called *extract coding*.

The resultant signals were converted by an electronic translating device<sup>17,18,19</sup> into a routing instruction to the sorting machine. There are  $26^5$  possible sequences of signals and the largest number required is for inward street-sorting—for example, in Manchester about 15,000. Insufficient discrimination results from less than 5 extracted characters. Each key on the keyboard generated a 5-bit binary word and

the full keying sequence was converted into one of the 144 answers. Conversion was effected by a matrix of magnetic cores each with a square hysteresis characteristic. The matrix was nominally composed of 5 columns of 26 cores, one column for each of the five keystrokes and one core for each letter of the alphabet. (Additionally, cores corresponding to numerals to cater for the London District numbers were also provided.) The core matrix was threaded with a network of wires, one for each of the conversions required; each wire therefore spelt out, in terms of threaded cores, one of the series of characters keyed when the operator used either extract rule.

Every key depression set one core, and on receipt of a *read* pulse applied to the whole matrix, only one of the threading wires was subjected to the effect of a magnetic field change in 5 cores. (All others, four or less.) Recognition of the signal was therefore achieved and, in a similar fashion, the magnetic field change technique was employed to generate a set of signals to control the sorting machine.

### FURTHER STAGES IN MACHINE SORTING TECHNIQUES

The extract keying system effectively overcame the inward sorting difficulty but it also stimulated renewed interest in a long-considered scheme for automatic letter sorting; this was to be achieved by coding each letter with marks on the envelope in a machine-readable form. The address would be read once only by an operator controlling a special printing device to effect the code-marking, leaving the actual sorting to be performed by an automatic machine reading these marks. This technique of code sorting has the outstanding advantage that it reduces the repeated readings of the address that are normally required for sorting between pillar box and letter box, to a single reading if sufficient information is printed when the address is first seen. Such a scheme<sup>20</sup> offers great service and economic advantages and it became the research and development objective about 1960.

Although code-sorting was theoretically attractive, a formidable list of problems existed which for solution required a strong element of invention; the task was unique in several ways and the machinery had to be evolved from basic principles. The problems stemmed mainly from the diverse nature of the letter mail, the high rate at which the items had to be transported, the near perfect accuracy (99.5 per cent at least) required and the very high handling efficiency which had to be attained. Unparalleled problems arose during the development of the code-mark printer due to the short time, about 25 ms, available for drying the marks on all types of envelope paper and the need for a low-cost solution.

During development,<sup>21</sup> four new main units appeared, two mechanical and two electronic. The two mechanical devices were based on the earlier single-operator sorting machine. The first, termed a coding desk<sup>22,23</sup> (Fig. 16) provided an operator with automatic letter presentation, a keyboard<sup>24</sup> and means<sup>25</sup> for printing sorting information in binary code form on each item (Fig. 17). At this stage, the operator was instructed to continue to extract the information required from the address. The keyed signals were received in an electronic coding desk translator<sup>26</sup> (capable of serving up to 64 coding desks) which converted the signals into an instruction for the operator's code-mark printer. The second new mechanical unit (Fig. 18) was virtually the selection box section of the operator-controlled sorting machine, but with a photo-electric code-mark reading device replacing the operator. This device read the code-mark pattern on each letter and referred the information to another electronic translator capable of discriminating between all possible and meaningful trains of signals. The 4,096 (equals  $2^{12}$ ) different patterns of marks allowed a degree of redundancy and reserve. This translator (which could serve up to 30 sorting

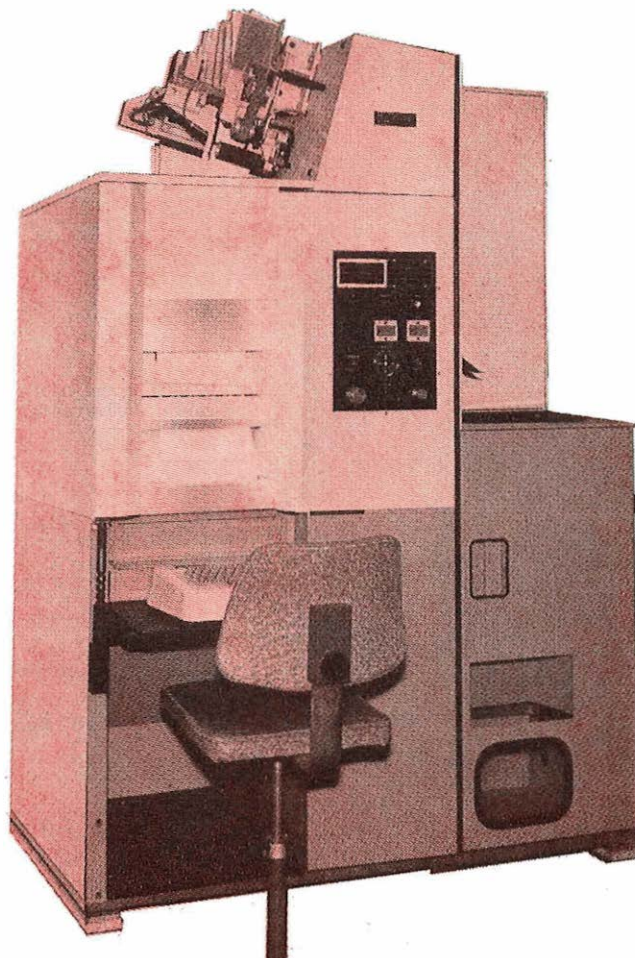

FIG. 16—Coding desk

machines) returned an appropriate instruction to the various letter routing devices embodied in the sorting machine to direct each item to the desired destination box.

The coded address-patterns were printed as two separate rows of dots, one representing the street and the other, the Post town. Each row comprised fourteen dot positions. The first dot functioned as a *start* dot to trigger the *reader*, the following twelve carried the information whilst the fourteenth was used as a checking mark which was printed or omitted as necessary to bring the total number of dots present to an even number. This gave a satisfactory degree of code checking. In order to avoid defacing the mail, and avoid misreading on paper which might fluoresce, the code marks had to be printed using a luminescent ink which was similar to that used for coding the stamps for facing, but which responded to a different excitation wavelength.

On small envelopes, one or two code marks may be printed on the stamp and therefore at the sorting stage the luminescent effects must be exclusive. This means that the material (often referred to as a phosphor) which responds to the shorter wavelength of ultra-violet radiation must be that used for the facing process. The facing ink reacts to 2,537 Å but not to 3,650 Å, and the sorting phosphor is energized by, and reacts to, 3,650 Å. No light signal from the facing phosphor therefore interferes with sorting.

### POSTCODES

Although the above machines and techniques of operating removed the need for any geographical knowledge on the part of the operators, a small proportion of ambiguous keyings was produced where the abbreviation gave the same

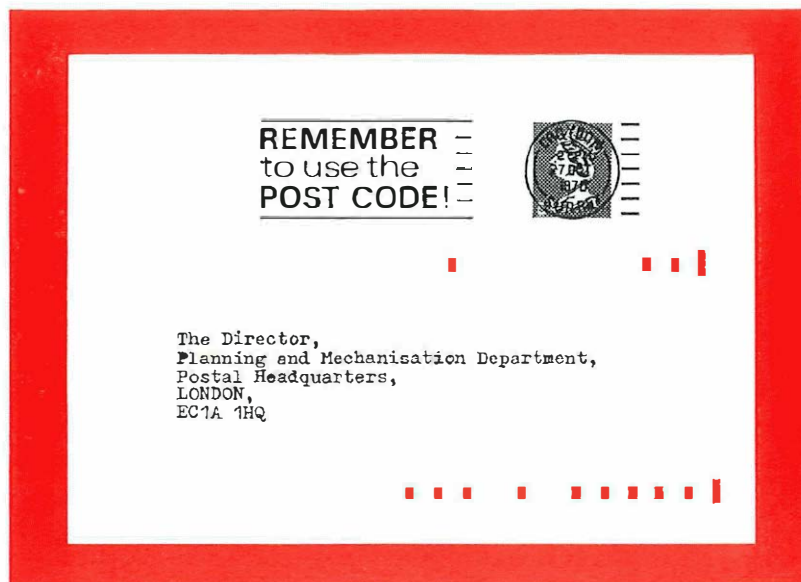

Note: The code marks have been coloured for illustration—they are normally invisible

FIG. 17—Letter showing position of code marks

result for different addresses (e.g. **BRIGHTON** and **BRIDLINGTON: STATION ROAD, STRATTON ROAD**). A further disadvantage was that the system did not permit full exploitation of codemarking. This is especially valuable for inward sorting, for it is the manual delivery sorting operation which is particularly difficult. Several postmen may be required to deliver in long streets and under extract coding of reasonable length some additional sorting by hand is required. There is also a continual necessity to re-arrange postmen's walks because of changes in the work loads; the extract system does not allow this, except on a whole street basis.

Whereas there is no problem in storing code-sorting information for all the Post town names in the country and all the street names in one delivery area (even the size of Birmingham) it is a problem of a higher order to store information to cover all the different names of all the streets in the United Kingdom—perhaps a total of 0.1 million. Such equipment would be essential for a simultaneous outward and inward extraction process by a single operator. The primary function of a translator for this operation would be to reduce the number of code marks to the minimum. It would be necessary to have a storage capacity of about 5 million bits in a fast access store which would be very costly. But without this there is a significant extra cost in the two separate passes required through coding desks, one at the office of posting, the other at the office of delivery.

Fortunately, there is a more subtle solution<sup>20</sup> which introduces additional advantages. It is based on the allocation of Postcodes to important delivery points and to small groups of addresses; a solution, however, which is more demanding for both the user and the designer.

The Post Office is currently engaged in providing every house and establishment in Britain with a coded form of postal address containing sufficient information to guide any letter from source to the appropriate delivery postman.

The form of this Postcode is fast becoming familiar; it is a five, six or seven character alpha-numeric code in two parts. The first part contains the distant sorting office outward information as well as that for its major divisions. There are several forms of this part of the code; some dictated by the

historical use of district designations in large cities. Examples are:

- AB1 = Part of Aberdeen
- SW18 = London S.W.18.
- W1A = Part of London W.1.
- EC1A = Part of London E.C.1.
- B2 = Birmingham 2.
- B39 = Birmingham 39.
- NPT = Newport (Mon.)

The whole country will be postcoded by the end of 1972. There will then be about 2,000 different outward Postcodes each associated with up to 2,000 inward Postcodes. (This gives 4 million out of a possible maximum of about 16 million allocations.) It should be noted that the alpha characters in the outward part represent recognizable geographical areas, such as EC and B; the numerals refer to delivery districts within these areas. Such a numerical breakdown was essential in large cities under manual conditions and has become well used. The mechanized system will extend the use of numbered districts. The second part contains the delivery information; this is invariably: numeral, alpha, alpha; examples are: IRF; 2NU; and 8PS. For this inward part not all the alpha characters are used since C, O, K, M, I and V can be confused, for example, with G, Q, R, N or W, 1 or 7 and U. (Similar care is used in the allocation of new outward Postcodes.)

The inward post-coding divisions are the minimum which allow practical re-allocations of postman's walk routing to take place as required by traffic changes without having to change any Postcode. Computers may be used in future to plan the duties, taking into account distance walked, weight of traffic and time factors; the code-units, or street links, will greatly assist this work.

If a Postcode is added to the address, the coding desk operator has only to copy key it and, as a result of this single operation, two binary patterns of code-marks are printed on the envelope (Fig. 17), sufficient to guide it through any route in the national system and finally to the delivery postman without any further individual attention.

The question is often asked, "why not all figures for Postcodes?" as is the case for telephone numbers. Since the postal



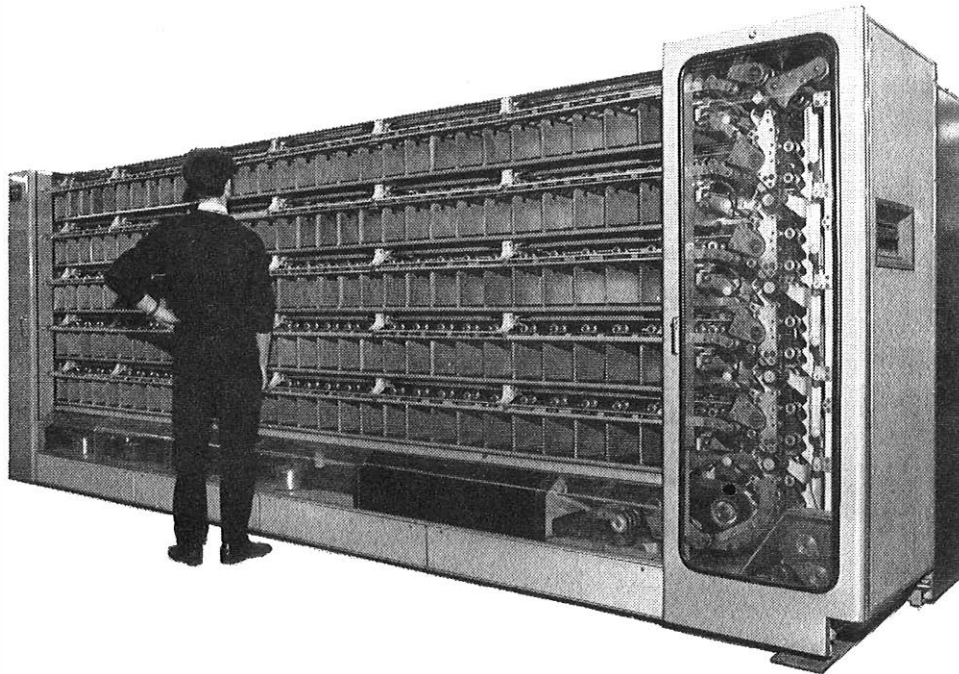

FIG. 18—A 144-selection, automatic letter-sorting machine

equivalent of the dial is a keyboard, the code is not limited to 10 symbols. Alpha characters give greater freedom of choice with more selections and therefore a shorter code. This is important to the customer and to the Post Office. All numerical Postcodes would also have led to a greater number of service errors, particularly in the absence of redundancy, through accidental transposition of figures. Before a decision was reached, however, human-factor trials were undertaken to compare alpha-numeric codes with all figure combinations and these showed that the former codes have the overall advantage in the postal application.

The British Postcode is the first in the world to encompass delivery sorting. Outward codes which in effect shorten only the destination town have only limited use but can all be published together (as has been the case, for example, in Europe and the U.S.A.). But the British Postcodes have been published locally, an area at a time, in order to allow each locality to introduce and become well used to the system prior to the installation of the equipment.

#### THE NEW LETTER MECHANIZATION SYSTEM AND PROGRAM

It will have been appreciated that increasing manpower cost is the dominating factor in the economics of postal operations and its effect is magnified by the high peak of traffic in the busy hour. About 80 per cent of the daily load is received in a three hour antisocial period for duty—1700 to 2000 hours. The ratio of peakhour to average therefore approaches 10 : 1 compared with 3 : 1 for telephone calls and 2 : 1 for electricity. The outward postal load is spread, firstly by setting suitable collection times and allowing an hour or so for processing before dispatch, and secondly by traffic division combined with deferment of the less urgent part. The latter, prior to the two-tier system, was achieved by the cheaper printed-paper rate and resulted in a 60 : 40 division. The two-tier system is really the same principle differently applied—although ironically not accepted as such—and it has reversed the ratio so that 20 per cent less of the traffic needs to be completely processed within the busy period. Division of the load does not change the maximum

capacity required for the initial processes, i.e. up to the facing stage, whether in terms of manpower in the manual system, or equipment in the mechanized one. Without the two-tier system the growing volume of urgent business mail had led to serious deficiencies in the manpower available in the peak period for sorting purposes, thus causing increasing service failures. This threat has been largely removed by the reversal of the 60 : 40 ratio; further, the base-load of second class traffic can be applied to the code sorting machines in a more economic manner and fewer coding desks are required for the peak period. A further system advantage introduced with the two-tier system, and of great significance to mechanization, is the sealing of all envelopes.

There is another and much more important system change to be exploited. Delivery, within 17 hours or so of posting of all first-class mail to 95 per cent of all potential inland addresses, is currently achieved by using a highly complex circulation system between the 1,600 sorting offices needed. Substantial economies, including that of scale, could be obtained by a major reduction of the number of sorting centres. This would lead to a large decrease in handlings from the current 250 million per day, a greater concentration of work and a simplified circulation system. In the manual system, concentration is only feasible for outward sorting; at the inward end, any significant degree of concentration is ruled out because it poses an impossible memory feat for the sorters—their knowledge of the addresses and delivery rounds involved extends only to their own locality. In the automatic system, with the aid of the Postcode and computers the concentration of the inward traffic is limited only by the time required for automatic sorting (about 1 hour) plus the transport interval to the outer delivery areas, having due regard to service requirements. In fact, concentration is feasible with an express network fully interconnecting less than 10 per cent of the present 1,600 offices, the remainder continuing to serve as local delivery offices. These, in the main, will be linked to parent mechanized letter offices (M.L.O.) by the Post Office road fleet. In this way, ultimately, the whole sorting operation could be effected, at some 120 strategically-placed M.L.O.s, giving enormous simplification.

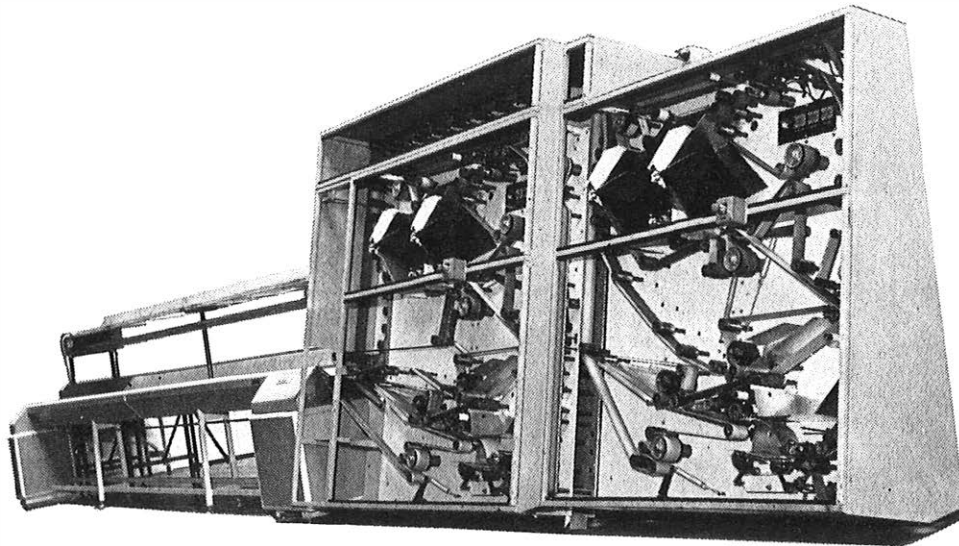

FIG. 19—The new facer canceller table

The productivity advantage to be gained from a theoretical mechanical sorting system exceeds the highly desirable order of magnitude necessary to justify a major changeover. The operator's output whilst Postcode keying can average twice that for manual sorting, the 144 selection automatic sorting machine (speeded up to 9,000 or more letters per hour) has three times the number of selections and the simplified circulation network requires only one or two sorts in which a man is involved, compared with three or four.

The high degree of machine utilization in this system would save the equivalent of some 15,000 postal staff and the new streamlined circulation network would provide management with the opportunity for a more efficient and reliable service in which only 40 million (compared with 100 million) address readings are required per day in total. Plans for bringing all this about are at present being negotiated with the staff associations. Much is involved in the many changes which such a mechanized system requires, for management, staff and the public. Progress has been made with the rebuilding program, but many of the existing sorting offices are up to 100 years old and unsuitable for the present as well as for the new system. The total investment program is of the order of £150M; about £100M in new buildings and £50M in equipment. The transformation planned should take no more than a decade or so to complete.

### CURRENT DEVELOPMENTS

There are too many projects in the research and development program for all to be mentioned here; indeed it would not be appropriate to do so in an article surveying progress to date. Some of those recently completed have solved seemingly intractable problems.

The letter handling mechanization now being applied is based on separate machines for the main stages of segregation, facing and sorting. This has permitted the development of a flexible code-sorting system in parallel with the proving of the effectiveness and reliability of the equipment from the economic, operational and engineering viewpoints. Although improved models of machines will be forthcoming and advances made in maintenance techniques, the next logical step is the linking of equipments wherever it is advantageous. (Experience had proved that it was right not to attempt this in the first stage.) An important recent development<sup>27</sup> has provided the means for such linking. It is a versatile device

capable of accepting a random stream of mail at a rate of up to 30,000 items/hour with provision for ordered stacking and subsequent de-stacking into a high-velocity spaced-stream. The device can, therefore, act as a buffer stage as well as a link between processes.

An additional application of this new device has provided, for the smaller offices, an improved manual facing table in conjunction with an automatic cancelling-stacking unit (Fig. 19). This equipment is being evaluated operationally and promises to provide important manpower savings in offices where the traffic is too small to warrant the provision of the standard ALF machine.

In the realm of electronic control the role of computers and data processors is under critical scrutiny. In particular, a major study of a new translator system for letter-code sorting is being undertaken. The new system will permit translations relating to a combined 24-bit code, formed from the present 12 bit inward and outward codes, to be made. This will result in increased flexibility in sorting-machine deployment and a substantial reduction in the numbers required. The aim is to design and construct a prototype equipment for practical trials in 1972.

### Research into Optical Character Recognition

The most important research project is the development<sup>28</sup> of a machine to read typescript Postcodes automatically. At the present time there is no O.C.R. equipment available of sufficient accuracy to read Postcodes without imposing further constraints on our customers. The new machine must accept a wide range of typefaces, be relatively insensitive to low contrast and quality, and whilst it may reject a fair proportion of the mail offered, even up to 20 per cent, it must not make more than 0.3 per cent errors in code reading. Existing commercial machines either match templates or determine characters from the presence and disposition of instinctively derived features, such as lines, curves, corners, etc., and whilst they work extremely accurately on high quality copy cannot approach the performance required on the variations of type and quality found on mail. A new technique has therefore been evolved, in which features are derived by an adaptive learning machine, a computer under human control and preconditioning, which derives features and optimizes its responses with ever improving accuracy when a large set of characters is fed into it. The features, which

must be independent of one another, are such that their presence or absence determines the signals of a binary error-correcting character-recognition code. In this way, from a relatively low accuracy of feature recognition, a very high accuracy of character recognition can be obtained.

For a full alpha-numeric character set a more complicated arrangement is required, and much work is still needed to optimize the particular arrangement that will be employed. However, the recognition of numerals with the required accuracy has been demonstrated and work at present in hand on alphabetical recognition is very encouraging.

Recognition is, however, only part of the problem, for the Postcode must first be located, the characters need to be separated, normalized in height and aspect ratio, and centred in a frame of reference. Study of any typescript will show how uneven spacings and lines are and that serious defects often occur in the characters printed. The research work must take these difficulties into account. It will also be necessary to develop higher-speed letter-feed units, smooth running transporting devices that permit accurate code location, scanners and high-speed phosphor code-mark printers compatible with the current system. After two years' further research it is hoped to demonstrate a prototype reading inward postcodes; practical working machines may follow soon afterwards.

The O.C.R. task may in time become easier if constraints can be (as in one or more other countries) introduced in address format; such questions are for the future and might best be resolved after Postcodes have become firmly established.

Automatic reading equipment, when ready, will take over increasingly the role of the coding-desk operator but (as for the telephone service) complete automation of the letter post cannot be foreseen; there will always be a proportion (though diminishing to an as yet incalculable minimum) of mail which will require the personal attention of an operator. The two systems will work in parallel, the O.C.R. equipment automatically referring unreadable addresses to the equivalent of a coding desk operator, who may be remote from the machinery, viewing the items by closed-circuit television.

## CONCLUSION

This three-part article has described the significant stages in the development of machinery and of the systems for handling parcels and letters. Work on testing and advanced maintenance equipment using data processors, on the overall design and project control of major installations, and on commissioning and economic maintenance procedures will be covered in articles in future issues of this Journal.

Postal Engineering encompasses many complex and difficult tasks involving the electrical mechanical, and material sciences in wide aspects. Mail has certainly proved to be a most intractable material for automatic machine handling, but the difficulties have been overcome for the first generation of equipment. Commissioning of this is increasing rapidly leading to transformation of the postal system.

The study of human factors will continue to be of primary importance since the interface between man and machine will remain in the sorting office. In addition, the engineer must appreciate that the first and last concern of the business is for its customers and the quality and cost of the service provided.

British developments only have been described in this article. So far there have been few signs of international standardization in techniques; the postal administrations of most countries, although united in agreeing to broad operational standards for external mails, retain different internal services requiring a variety of methods to accommodate national mail characteristics. The British Postal Engineering Conference of May 1970, in which 21 countries participated, set the scene for a continuing international dialogue.

## ACKNOWLEDGEMENTS

The author wishes to acknowledge all the assistance given in carrying out this review. In particular he has been greatly helped in all three parts by Mr J. Piggott; in the second part by Mr C. E. Clinch and in the third by Mr G. P. Copping. Although the story traces the emergence of a new technology the progress described in this would not have been feasible without the participation over the years of postal operational experts; this is best acknowledged by special reference to Mr R. O. Bonnett and Mr D. Stewart, two of their recent leaders.

## References

- <sup>1</sup> Esther iii. 12-15; viii. 10; I Kings xxi. 8.
- <sup>2</sup> HILLS, E. G. Segregating; Operational Requirements and Development. I.Mech.E. British Postal Engineering Conference May 1970, Paper No. 7.
- <sup>3</sup> TOTTEY, S. T. Segregating and Grading Machines for Letter Mail Handling. I.Mech.E. British Postal Engineering Conference, May 1970, Paper No. 40.
- <sup>4</sup> COPPING, G. P., and MYERS, T. R. Mechanization of Initial Stages of Processing Mail. Part 1: Segregation of Various Classes of Mail. *P.O.E.E.J.*, Vol. 52, p. 286, Jan. 1960.
- <sup>5</sup> COPPING, G. P., GERARD, P. S., and ANDREWS, J. D. The Automatic-Facing of Letter Mail. *Mechanical Handling*, April and May 1959.
- <sup>6</sup> ADAMS, G. F. Letter Facing Machines, Development and Design of Production Machine. I.Mech.E. British Postal Engineering Conference, May 1970, Paper No. 41.
- <sup>7</sup> COPPING, G. P. Automatic Letter Facing. I.Mech.E. British Postal Engineering Conference, May 1970, Paper No. 17.
- <sup>8</sup> WICKEN, C. S. Control Systems for Automatic Letter Facing Machines. I.Mech.E. British Postal Engineering Conference, May 1970, Paper No. 18.
- <sup>9</sup> FORSTER, C. F. Phosphorescent Code Marks in Automatic Letter Facing and Sorting Machines. *P.O.E.E.J.*, Vol. 54, p. 180, Oct. 1961.
- <sup>10</sup> HARRISON, J. C., RICKARD, E. F., FORSTER, C. F., and WALKER, A. D. Preparation, Properties and Application of Luminescent Organic Resins for Letter Facing, Classification and Address Coding. I.Mech.E. British Postal Engineering Conference, May 1970, Paper No. 4.
- <sup>11</sup> AGATE, M. S. Assessment of the Performance of Phosphor Postal Items. I.Mech.E. British Postal Engineering Conference, May 1970, Paper No. 23.
- <sup>12</sup> JENKINS, H. A. Postal Circulation. Post Office Green Paper No. 22, Oct. 1935.
- <sup>13</sup> ROWDEN, J. J. C. The Travelling Post Office. Post Office Green Paper No. 24, March 1936.
- <sup>14</sup> COPPING, G. P., and BEAK, K. L. A. A Single Operator Letter-Sorting Machine. (Introduction and Experimental Machine.) *P.O.E.E.J.*, Vol. 51, p. 104, July 1958.
- <sup>15</sup> LANGTON, H. J. A Single-Operator Letter Sorting Machine. (The Production Machine and Future Development.) *P.O.E.E.J.*, Vol. 51, p. 112, Oct. 1958.
- <sup>16</sup> GILES, B. E. Mechanical Sorting of Coded and Uncoded Mail. I.Mech.E. British Postal Engineering Conference, May 1970, Paper No. 15.
- <sup>17</sup> ANDREWS, J. D. A Code Translator For Letter Sorting Machines. *P.O.E.E.J.*, Vol. 52, p. 199, Oct. 1959.
- <sup>18</sup> ANDREWS, J. D., and BELCHER, P. L. Time-Shared Code Translators for Letter Sorting Equipment. *P.O.E.E.J.*, Vol. 55, p. 173, Oct. 1962.
- <sup>19</sup> PILLING, T. Letter Post Automation. *Control*, July, August and September, 1964.
- <sup>20</sup> ANDREWS, J. D. Coding Principles and Practice. I.Mech.E. British Postal Engineering Conference, May 1970, Paper No. 12.
- <sup>21</sup> PILLING, T., and GERARD, P. S. Automatic Letter Sorting. The Luton Experiment. *P.O.E.E.J.*, Vol. 54, p. 31, Apr. 1961.
- <sup>22</sup> PILLING, T., and HORROX, P. Coding Desk and Code mark Reader for Use with Automatic Letter Sorting Machines. *P.O.E.E.J.*, Vol. 54, p. 122, July 1961.
- <sup>23</sup> KNOWLES, S. C. Development of a Letter Coding Desk. I.Mech.E. British Postal Engineering Conference, May 1970, Paper No. 22.
- <sup>24</sup> MUCKETT, R. G. Manual Keyboard Design. I.Mech.E. British Postal Engineering Conference, May 1970, Paper No. 27.
- <sup>25</sup> HEWETT, J. W., and MUCKETT, R. G. Code Marking of Letter Mail. I.Mech.E. British Postal Engineering Conference, May 1970, Paper No. 38.
- <sup>26</sup> GOODISON, H. Threaded-Core Translators. I.Mech.E. British Postal Engineering Conference, May 1970, Paper No. 9.
- <sup>27</sup> HILLS, E. G. New Mechanical Aid for The Smaller Sorting Office. I.Mech.E. British Postal Engineering Conference, May 1970, Paper No. 37.
- <sup>28</sup> COOMBS, A. W. M. On the Reading of Postal Codes by Machine. I.Mech.E. British Postal Engineering Conference, May, 1970, Paper No. 13.

# A New Generation of Auto-Manual Centres for London

K. R. CROOKS, C.ENG., M.I.E.R.E., A.M.B.I.M.†

U.D.C. 621.395.722: 621.395.33/34

*The decision to provide crossbar switching equipment, with stored-program control registers and cordless switchboards, at London's sector switching centres, has enabled many improvements to be planned in the handling of operator-controlled traffic. Enhanced transmission standards and the introduction of new facilities have led to a re-appraisal of the trunking and routing principles for such traffic in the local and main networks. This article describes how these features are being employed in the design of new auto-manual centres which will come into service in London in the 1970s.*

## INTRODUCTION

Since the inception of automatic switching, the auto-manual board has been the assistance point for subscribers requiring help from an operator in the completion of a connexion. Each manual board, with its associated switching equipment for answering and routing calls, is termed an auto-manual centre (a.m.c.). For many years, bridge and sleeve-control a.m.c.s, normally located within local exchange buildings, have been used to provide the necessary assistance facilities. There are at present approximately 60 such a.m.c.s with some 3,000 positions in the London director area, a number of which will require to be replaced, at new locations, for equipment or management reasons, in the next decade.

A new switchboard system, incorporating incoming-call queuing and cordless connecting circuits with key selection of outgoing services, was introduced at Thanet<sup>1</sup> in 1955. Another system, based on these principles, known as the Cordless Switchboard System (C.S.S.) No. 1, has become the standard for new a.m.c.s and, since early 1967, contracts have been placed for approximately 400 positions of this type for a.m.c.s in London. More recently, a further development of this system, called the C.S.S. No. 1A, has become available and contracts have been placed or are in the process of being prepared, for approximately 1,200 such positions, to be installed at 10 centres. The C.S.S. No. 1A a.m.c. differs from the C.S.S. No. 1 in the method of signalling to outgoing equipment and in the labelling of the outgoing routing keys.

Cordless a.m.c.s are being housed in trunk-exchange and office-type accommodation as well as in local-exchange buildings. In contrast with sleeve-control a.m.c.s, the cordless switchboard system requires selector access to all outgoing circuits.

## PLANNING OBJECTIVE

The principal objective in the design of new cordless a.m.c.s has been to provide single-operator assistance on the maximum number of calls via a manual board and, additionally, to reduce the need for the operator to make reference to the visible index file (v.i.f.) for routing information, etc. Improved transmission standards play an important role in the routing pattern adopted. The provision of TXK1 crossbar equipment with stored-program control (s.p.c.) at sector switching centres (s.s.c.s) has enabled many improvements to be planned for the handling of operator-controlled traffic from these centres, not the least of which is the facility for fast transmission of routing information directly into the s.p.c. register. However, where an a.m.c. must employ wholly Strowger switching equipment, facilities similar to those at

a.m.c.s serving s.s.c.s will be provided as far as the Strowger equipment permits.

## C.S.S. No. 1A (DIRECTOR AREA) FACILITIES

The list which follows is an outline of the main facilities of this type of a.m.c. and is not intended to be a complete list of services available to the operator.

### Incoming Calls

Incoming calls or enquiries are presented to the manual board, in the order in which they arrive at the a.m.c., by means of main and subsidiary queues. Each position is equipped with seven connecting circuits with associated SPEAK/MONITOR and timing keys.

### Outgoing Calls

Outgoing calls are initiated by depressing one of four select keys, coded LOCAL, LOCAL SERVICE, TRUNK and TRUNK SERVICE.

#### Local

Access to the local network is obtained by depression

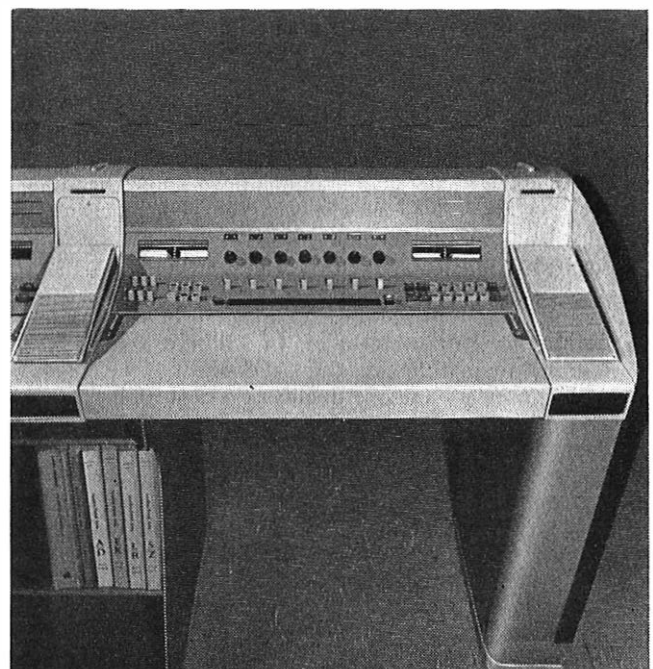

FIG. 1—A cordless switchboard position

† Trunk Planning Branch, London Telecommunications Region

of the LOCAL select key followed by keying the local all-figure number (ABC xxxx). In this context, the local network refers to subscribers in the London director area only and in consequence, no charging-group code need be keyed.

**Local Service**

Outgoing access to special operator facilities in the local network is obtained by depressing the LOCAL SERVICE select key, followed by keying a digit (1-0) to identify the required facility. Local service facilities and prefix digits being planned are shown in Table 1.

**Table 1  
Local Service Facilities and Prefix Digits**

Digits Keyed	Service
1 + xx	Access to emergency and inter-position services. Automatic holding of faulty connexions detected during the setting up of an operator-controlled call.
2 + xxxxx	
3 + ABC xxxx	Three repeat attempts at intervals of 10 seconds to gain access to the required junction route.
5 ÷ ABC xx...	Remote transfer-switching of subscriber's lines at parented exchanges.
6 ÷ ABC	Access to the repair service control (r.s.c.) in the London director area serving the respective ABC exchange.
9 + ABC xxxx	Trunk offering (TKO) access to all exchanges in the London director area.
0 + ABC	Access to the parent manual board of exchange ABC.

**Trunk access**

Outgoing access to the main network is effected by depressing the TRUNK select key, then keying the national number excluding the prefix digit 0. National-number keying will be used for access to the adjacent and non-adjacent charging-group exchanges.

**Trunk service**

Outgoing access to special operator services in the main network is obtained by depressing the TRUNK SERVICE select key. Service facilities being planned are shown in Table 2.

**Table 2  
Trunk Service Facilities and Prefix Digits**

Digits Keyed	Service
3 + xxx xxxx(xx)	Three repeat attempts at intervals of 10 seconds to gain national-number access to the required main-network route.
4	
7 + xxx ...	Access to an outgoing trunk n.d. unit (Kingsway), with repetition of up to 16 digits for inland routing.
8 + xxx ...	Access to Dublin incoming n.d. unit with repetition of up to 16 routing digits.
9 + xxx xxxx(xx)	National-number access for TKO to subscribers outside the London director area. (To be provided when a suitable multi-frequency signalling network is available.)
0 ÷ xxx	Access to the parent manual board of distant g.s.c. area exchanges by following the service facility digit with the required number-group code only. Provincial director area manual boards will require the addition of the local exchange code also, e.g. for parent manual board of subscriber 021-987 6543, the trunk service code keyed would be 021 987 (where 0 is the service facility digit).

Different arrangements from the above will apply to the processing of LOCAL SERVICE and TRUNK SERVICE facilities for those a.m.c.s that do not have access to stored-program-control equipment.

**Supervision**

Supervision of the progress of a call is provided by the illumination of press-keys and a display on miniature visual indicators.

**Call timing**

Call timing is available on each connecting circuit and starts automatically when the called subscriber answers.

**Release**

The operator releases a call by first monitoring the line and then operating the RELEASE key.

**Switchroom management aids**

Switchroom management aids are provided in the form of visual displays of main-queue length (waiting-call indicators), subsidiary-queue head occupation, and numbers of positions staffed. Key controls over main-queue length and closure are also provided, as are audible and visual alarms which operate when the call at the head of each main or subsidiary queue has waited longer than a preset period of time.

**ROUTING AND TRANSMISSION REQUIREMENTS**

A number of factors have influenced the routing requirements from a.m.c.s. Firstly, the basic transmission plan (1960) has required a re-appraisal of routes and transmission standards currently employed for sleeve-control a.m.c.s. The principle, that the transmission loss on calls via an a.m.c. should be no worse than the equivalent subscriber-dialled call, is being upheld wherever possible. Secondly, the introduction of register control of most local and trunk calls via the operator has required special consideration to be given to the location of the manual-board register-translator equipment in the relevant network. This particularly applies to London's

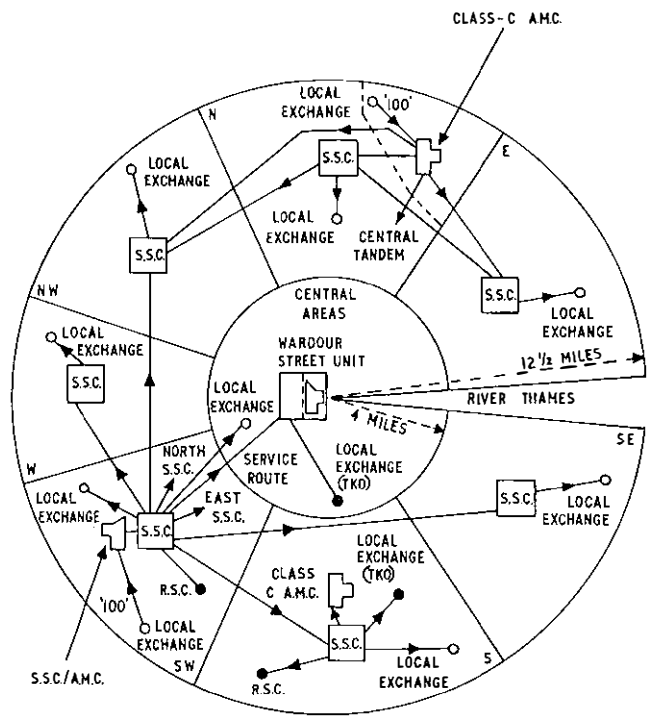
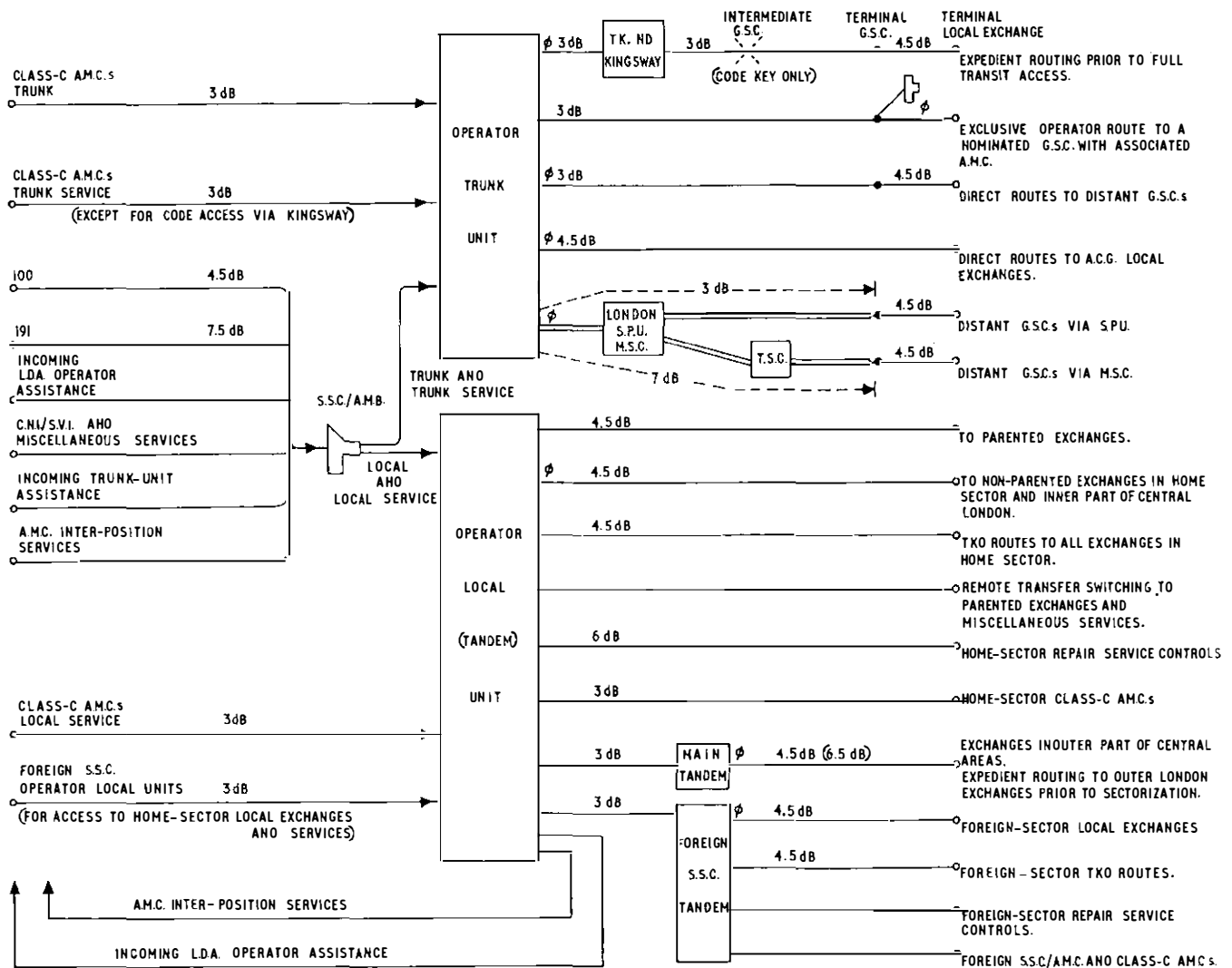

FIG. 2—Outline of a.m.c. routes from an s.s.c. and a sector class-C a.m.c.



ALL ROUTES ARE PROVIDED FOR EXCLUSIVE OPERATOR ACCESS EXCEPT THOSE MARKED  $\phi$  ON WHICH SHARED ACCESS WITH SUBSCRIBERS IS GIVEN.

FIG. 3—Routing pattern (with maximum line-transmission losses) for assistance calls switched via an s.s.c.

class-C a.m.c.s. (A class-C a.m.c. is an a.m.c. located remotely, beyond certain limiting distances, from the s.s.c. or g.s.c. register-translator equipment and into which the assistance (100) circuits are directly routed from the local exchanges in the part of the s.s.c. or g.s.c. area it serves.)

Thirdly, all s.s.c.s will be interconnected with routes for the exclusive use of the a.m.c.s in the respective sectors. This means that calls routed via an a.m.c. at an s.s.c. to an exchange in another sector will, unlike subscriber-dialled calls, be routed through two s.s.c.s over these exclusive links (see Fig. 2). It will be possible for an operator to use the same link for four different classes of call to another sector. These are:

- (a) calls to subscribers' multiple numbers,
- (b) TKO access to every exchange unit,
- (c) access to each repair service control (r.s.c.),
- (d) access to the appropriate parent a.m.c. without routing via the local-exchange final selector, as at present.

The receiving s.s.c. equipment will identify each type of call by class-of-service information forwarded from the originating s.s.c.

It will thus be necessary to create new star-connected networks from each s.s.c. tandem switching unit, to TKO

selectors at each home-sector exchange, to each r.s.c. within the sector, and to each parent manual board. Incoming assistance calls to each sector will be received by the s.s.c. incoming-trunk unit in the form 01 ABC or ABC 0001, or by the tandem unit in the form 00 ABC or ABC 0001 and will be routed direct to the a.m.c. in the sector parenting exchange ABC. This a.m.c. may well be remote from the ABC exchange building and hence the direct routing will offer a transmission improvement of 3 dB (when compared with current practice) on that proportion of calls requiring second-operator assistance.

A fourth factor affecting the transmission and routing pattern is the advantageous position of the a.m.c. at an s.s.c. in the local and main networks. A subscriber parented on such an a.m.c., dialling either 0 for an s.t.d. call or 100 for assistance, will be routed to the s.s.c. on a circuit not exceeding 4.5 dB line transmission loss. (Similar standards have been applied for some time to a.m.c.s at provincial g.s.c.s, but London's outer areas will not operate in this way until the opening of the a.m.c.s at the s.s.c.s.) Therefore, as these operators will share all main network routes with s.t.d. traffic, the routing pattern and transmission standards will be similar for operator or s.t.d. traffic. One exception to this rule of shared routes is the escape route to a nominated n.d. g.s.c.



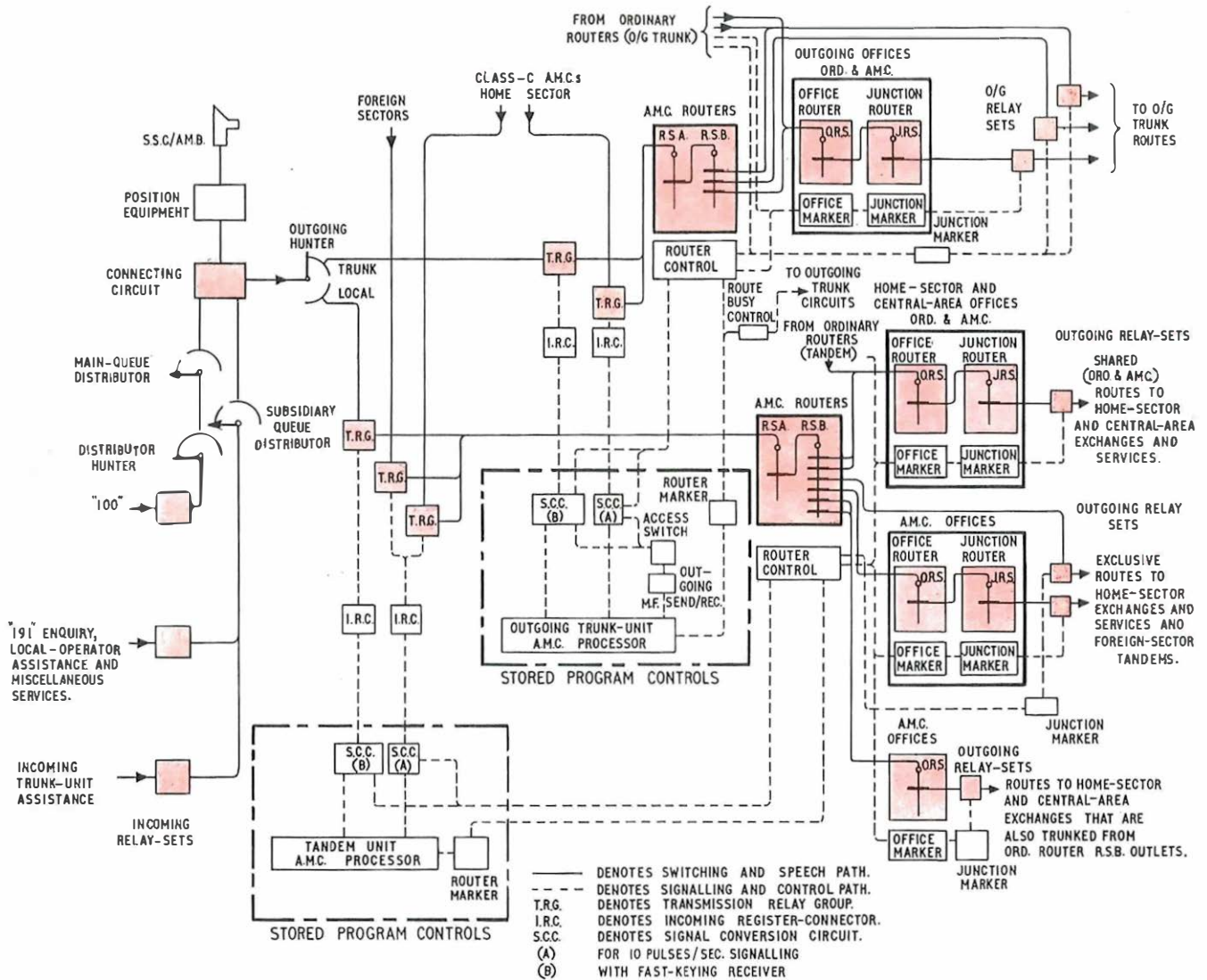

Fig. 5—Outline trunking diagram of a cordless a.m.c. associated with a London s.s.c.

(common control with mass marking) or Strowger equipment (2-digit group selector with serial selection).

### OPERATION OF OUTGOING EQUIPMENT TXK1 Crossbar Equipment with S.P.C.

Presenting incoming calls to an operator in the order in which they arrive is termed call queuing, the principle of which has been described previously.<sup>2</sup> Outgoing calls originated by an operator are routed through the s.s.c. crossbar equipment. This equipment is trunked as three separate blocks, each controlled by separate s.p.c. registers. These blocks are called the *outgoing trunk unit*, the *incoming trunk unit* and the *tandem unit*. The a.m.c. at the s.s.c., however, depends upon all three units for its correct functioning and Fig. 5 outlines the trunking of an s.s.c. as applicable to the a.m.c. with additional inputs from the home-sector class-C a.m.c.s and foreign-sector tandem units. The parts of the diagram shown in red indicate the groups of equipment that remain in the speech paths of all classes of call.

The s.p.c. equipment is fundamentally a purpose-designed computer which operates on demand and controls the switching functions required to set up a call through an exchange by means of instructions fed from a program store. The ability to alter the stored program provides a flexible method of changing or adding facilities with a minimum of interference to in-service equipment. As the s.p.c. functions at

high speed and is normally time-shared between a number of calls, relatively few such equipments are necessary. Certain s.p.c.s in the tandem unit and the outgoing-trunk unit are provided exclusively for the a.m.c. and are programmed to control the wide range of service facilities previously described.

An outgoing call from the a.m.c. at an s.s.c. is initiated by the operation of the appropriate select key (i.e. TRUNK or TRUNK SERVICE or LOCAL or LOCAL SERVICE) which causes the outgoing hunter to find a free transmission relay group (t.r.g.) in the appropriate outgoing-trunk or tandem unit. Select-key and subsequent digital information is transmitted by fast-d.c. signalling, using a 1-out-of-5 code, to incoming t.r.g.s of the fast-d.c. type. Other t.r.g.s accept 10 pulses/sec signalling from class-C and foreign-sector a.m.c.s and indicate the class of service to the processor in order that the relevant program of facilities may be followed. A crossbar switch is employed as the incoming register connector and serves to connect the t.r.g. to a register, a register being regarded as a signal-conversion circuit (s.c.c.) and the register area of the processor.

In the following paragraphs, the term "office" is used. In this context, it means a group of crossbar selectors serving as further switching stages for a particular class of call.

Digital information is now fed to the register for identification of the route or service required. When sufficient information is stored in the processor to identify a route address, an associated router marker sets up a fast path to the appropriate



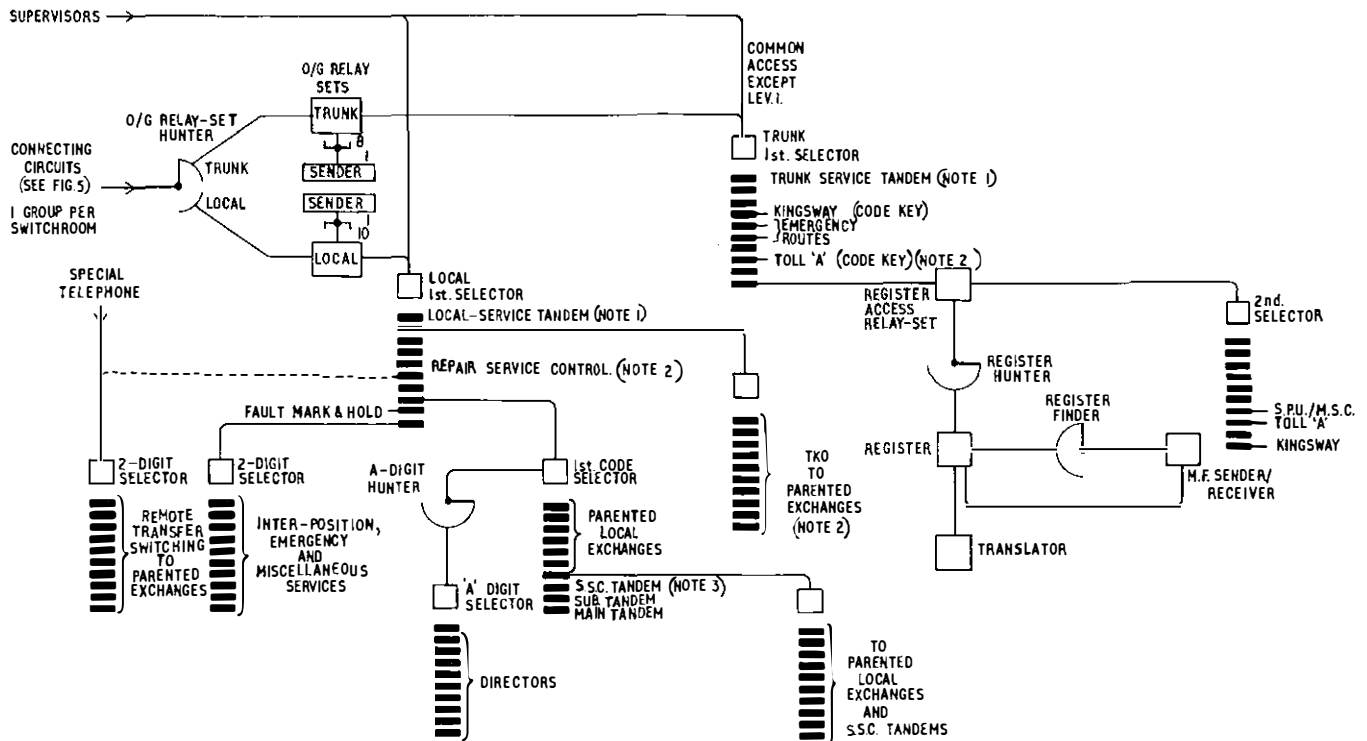

- Note 1: Levels reserved for access to an operator-services tandem (Wardour Street W.1)
- Note 2: These routes will cease when an operator-services tandem is operational
- Note 3: Routes to each of the 7 sector tandems will ultimately be required

FIG. 6—Typical trunking of a C.S.S. No. 1A a.m.c. with Strowger equipment in central London

router control and passes the routing information to it. Subsequent communications with the processor pass via the s.c.c. to the router control or t.r.g. As soon as the router control has been seized, a route-marking signal is forwarded to the junction marker directly, or via an office marker to the junction marker if office-route-switch stages are employed. The marks (an earth condition on the M leads) are applied to all free circuits in the required route or part of the route. These are extended back over the trunking links, using the self-steering principle, to the calling t.r.g. inlet of the router. The router control will have primed this inlet to recognize only those marks appropriate to the call being set up. A bridge magnet in each stage of switching will now be operated and one path will be established between the t.r.g. and outgoing relay-set.

In Fig. 5 it is shown that incoming and common-control equipments are provided for the a.m.c.s on an exclusive basis, in order that the special facilities can be provided. Similarly, so as to provide exclusive trunking to exclusive routes, the tandem and outgoing-trunk units of the s.s.c. are equipped with a.m.c. routers for the first and second stages of switching. Where further expansion is required, a.m.c. offices are employed.

Subsequent to the seizure of an outgoing circuit and a check of the continuity within the exchange, further out-pulsing will normally be required, and this is dictated by the sending program in the processor. After examining all the relevant input information, the processor will decide whether omission, translation or repetition of the stored digits is necessary and the required signalling mode. The t.r.g. accepts from the register such further routing digits as are required and forwards them over the speech path now set up via the router (and outgoing office) to the outgoing relay-set previously selected, for onward transmission in

the appropriate line-signalling system. On completion of the sending program, the register releases and the supervision and transmission of the call proceed under the control of the t.r.g.; the t.r.g. returns line-supervisory signals to the a.m.c. connecting circuit for indication on the operator's position.

The above principle of operation of the s.s.c. is similar to that for outgoing subscriber-dialled calls.

### Strowger Equipment

C.S.S. No. 1A class-C a.m.c.s are designed at present using Strowger switching equipment. Where it is not possible to employ the trunk facilities at s.s.c.s (e.g. in central London), access is provided to shared or exclusive trunk register-translators. Fig. 6 shows the trunking diagram of a typical Strowger-equipped a.m.c. in central London. The fast d.c. keying signals referred to earlier are received by the appropriate local or trunk sender at the C.S.S. No. 1A and converted into Strowger pulses. Operation of the LOCAL or TRUNK select key causes the sender to generate a pre-determined digit which steps the local or trunk first selector to the level from which register translators are trunked. In the case of local calls, the director area a.f.n. is then passed in Strowger form via a first-code selector to the A-digit selector and director equipment. The translation obtained routes the call via the code selectors to the parented exchange's exclusive routes or to tandem exchanges for access to the remainder of the exchanges in the London director area. All other local services currently require to be code-keyed into the local first selector, each service being identified by a local-service prefix digit. These services are as follows:

- (a) inter-position and emergency services,
- (b) mark and hold of faulty connexions,
- (c) repair service controls,
- (d) TKO to parented exchanges.

Remote transfer switching to parented exchanges is effected by dialling a 2 + 2-digit code, from a table unit and telephone, into a 2-digit group selector. This facility is divorced from the C.S.S. positions except under key control to avoid the possibility of inadvertent miskeying by operators causing the switching of a subscriber's line.

Access to the main network will generally be by national-number keying into the register-translator but, until the transit network provides for full s.t.d. access, operators will require code-key access to a trunk n.d. unit, such as Kingsway.

## CONCLUSIONS

The developments outlined in this article represent a considerable advance in the philosophy and design of auto-manual centres. Some improvement in call-handling times is expected as simplified operating procedures are introduced. The cordless switchboard also offers a more attractive working environment due to the enhanced accommodation standards. Even greater improvements are to be expected, however, from

the development of the cordless switchboard system No. 2. In this system, it is envisaged that automatic ticketing or metering of calls, remote location of positions and improved concentration and distribution of calls to positions, will give very substantial savings in call-handling times and increased flexibility in the location of a.m.c.s.

## ACKNOWLEDGEMENTS

The author wishes to thank Messrs G.E.C.-A.E.I. Telecommunications, Coventry, for their assistance and for permission to publish the trunking arrangements for the s.s.c. and its associated a.m.c. Acknowledgement is also due to colleagues at the London Telecommunications Region and Telecommunications Headquarters.

## References

- <sup>1</sup> MISSEN, L. A., SNOOK, R. A., and HITCHIN, E. J. T. Thanet Cordless Switchboard. *P.O.E.E.J.*, Vol. 48, p. 102, July 1955.
- <sup>2</sup> CHEESBROUGH, J. Stafford Cordless Switchboard. *P.O.E.E.J.*, Vol. 54, p. 201, Oct. 1961.
- <sup>3</sup> FRANCIS, H. E., and DAVIS, E. Decentralization of London's Trunk and Tandem Telephone Exchanges. *P.O.E.E.J.*, Vol. 59, p. 75, July 1966.

---

# New Duct for the Protection of Shore-Ends of Submarine Cables

G. C. BACKSHALL, M.I.T.E.†

U.D.C. 621.315.671: 621.315.28

*Submarine cables are armoured to protect them when laid in shallow water and on a beach and further protection is given by burying them. On rocky beaches, where the cables cannot be buried, they require additional protection and special cast-iron split-ducts have been introduced.*

## INTRODUCTION

Submarine cables are landed on many kinds of beaches. Generally, they are buried to a depth of two feet in the beach to prevent their being damaged, but this may not be possible on a rocky foreshore. Where the cables are exposed, they are liable to mechanical damage by rocks and stones which are moved by waves or tide. The greatest amount of damage occurs between the high-water and low-water marks, where wave action is at its greatest. Additionally, exposed cables are sometimes damaged by vandals and this cause can be expected to increase. To protect and strengthen submarine cable in shallow water and on a beach, the cable is armoured.

The armouring usually consists of a single or double layer of mild-steel wires laid on a jute bedding over the cable sheath and a further covering of jute is laid over the armouring. Single armouring is normally composed of about fifteen mild-steel, size 2 or 4 s.w.g. wires, the exact number and size being

dependent on the size and the use of the cable. On a rocky beach, where the cable cannot be buried, even single and double armouring eventually erodes due to wave action.

The cable can now be given additional protection from erosion and vandalism by fitting special split cast-iron ducts. The two halves of the duct are placed around the cable and bolted together, and successive lengths of duct are coupled together to form a strong pipe around the cable as shown in Fig. 1. The cable is protected from just beyond the low-water mark to a point where it is buried at the top of the beach. This type of duct has been effectively used for many years by Cable and Wireless Ltd on some of their more rugged cable landings.

## DESCRIPTION

The split-ducts are made in cast-iron and shaped with ball and socket ends (Fig. 2) so that when coupled together, they can be angled slightly to follow any bends in the cable. The ducts are available in two sizes, one giving an

† Network Planning Department, Telecommunications Headquarters.



FIG. 1—Cast-iron split-ducts fitted to cable



FIG. 2—Cast-iron split-duct

effective length of 12 in and the other 24 in. Both have a  $3\frac{1}{2}$  in bore. The 12 in long duct is shown in Fig. 3. The two sizes of duct allow for bends down to 2 ft 6 in and 5 ft radius, and weigh 44 lb and 62 lb respectively. When laid on the beach, each end of the duct line is clamped to the cable with a wooden (Lignum Vitae) split-bush to prevent wear. Lignum Vitae has a long life under water. The split-bush is made in two sizes to fit the two end-sizes of the duct and has three different bores, 2 in,  $2\frac{1}{2}$  in and 3 in, to cater for most cable sizes. Any slack between the bush and the cable is taken up by packing the bush with synthetic yarn.

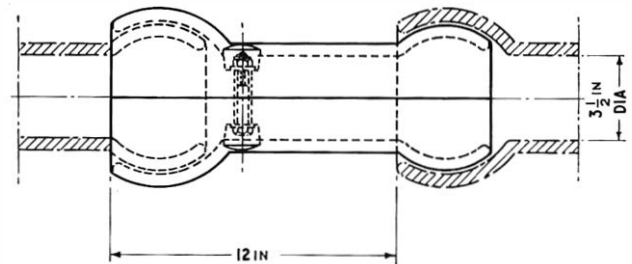

FIG. 3—Split-duct showing ball-and-socket joint

### USE OF THE DUCTS

The ducts may be fitted to shore-ends of cables where cable damage has occurred or may be anticipated. The 24 in duct is used where the cable run is substantially straight, and the 12 in duct is used where the cable bends sharply. A working party of three men is adequate to install the ducts, but additional men may be required when difficult access to the beach makes transporting the ducts a problem. The duct-laying operation is largely dependent upon the tide and usually commences at the top of the beach in order to gain maximum working time. Any work necessary above the high-water mark can be carried out in advance. The first duct laid around the cable is clamped to the cable with the wooden bush. The ducts may then be anchored by burying them with the cable or by concreting them into a sea wall or other structure. Laying the ducts proceeds down the beach

as the tide ebbs. The ducts may be laid beyond the low-water mark by supporting the cable on a boat or a raft (frequently made from oil drums) whilst the ducts are fitted from a second boat. When weather and beach conditions permit, the beach working-party can often complete the work by wearing waist-high waders. The number of ducts fitted beyond the low-water mark also depends on beach conditions. Up to 200 ft of duct can be laid in a day.

### CONCLUSIONS

The ducts will increase the life of a cable laid over an exposed beach and will reduce the damage caused by the abrasive action of boulders and stones. They will also make it more difficult for vandals to damage the cable.

# The Testing of Broadband Radio-Relay Links

R. A. MOORE

U.D.C. 621.39:621.371

*Broadband radio-relay links are now widely used to carry television signals, and a considerable network has grown up in which the various broadband channels are required to carry, in addition, multi-channel telephony, and multiplexed data traffic. This article sets out the general principles of testing broadband radio channels for quality of performance. Baseband tests related to multi-channel telephony, and the tests relating to the microwave and intermediate frequency sections of a broadband radio link which are relevant to all types of traffic are dealt with.*

## INTRODUCTION

The overall testing of television links, which may include sections of broadband microwave radio-relay link, has been described elsewhere in this journal<sup>1,2</sup>. This article describes the general principles of testing broadband radio links which are required variously to carry television, multi-channel telephony signals, or multiplexed data traffic.

The types of testing fall logically into five main categories:

(a) overall testing between baseband input and baseband

(b) the testing of modulator and demodulator equipment,

(c) the testing of link sections between intermediate frequency (i.f.) points, which includes local testing of i.f. amplifiers and switching equipment, and testing between i.f. points at adjacent radio stations,

(d) ultra high frequency (u.h.f.) and super high frequency (s.h.f.) testing. This includes the testing of u.h.f. and s.h.f. amplifiers, waveguide and coaxial feeders and aerial systems,

(e) the testing of auxiliary and miscellaneous equipment.

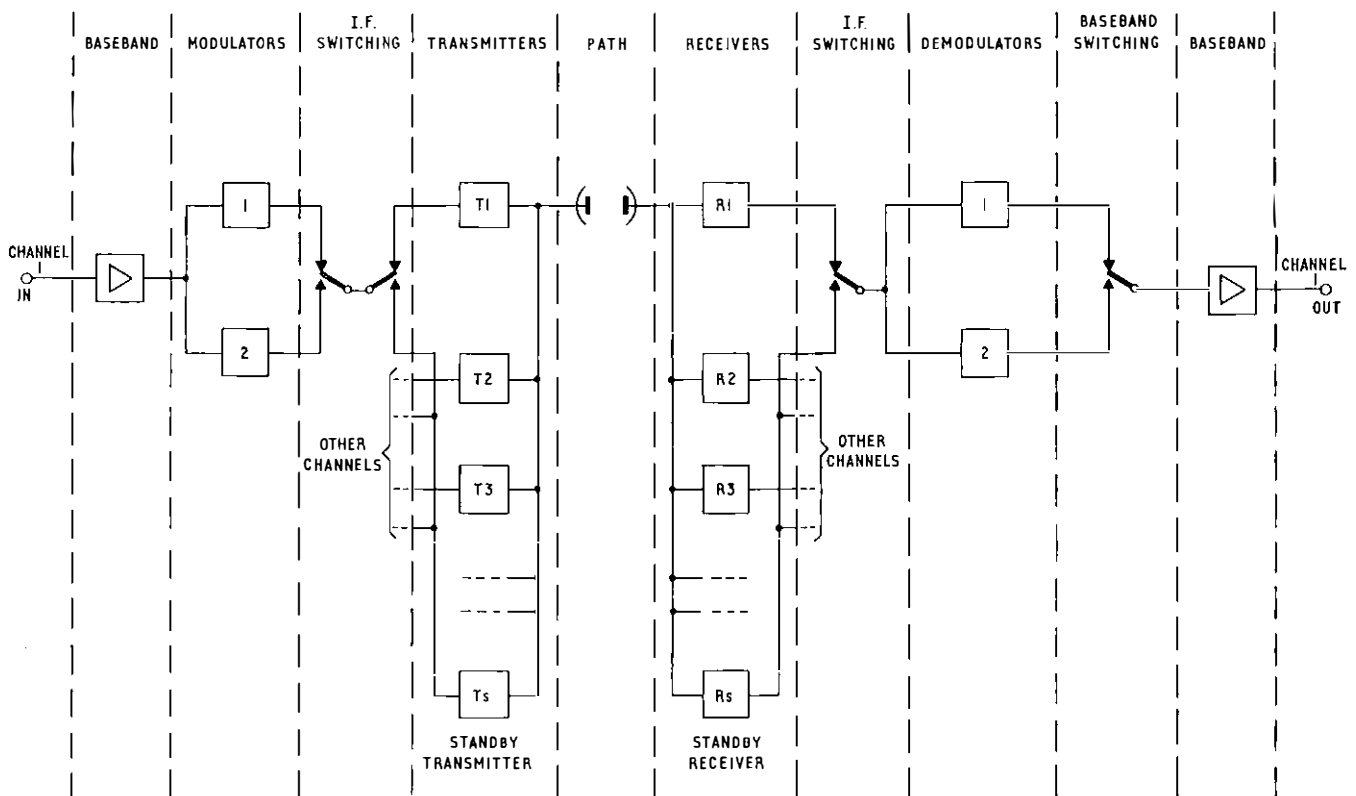

FIG. 1—Block schematic diagram of a broadband radio-link system

output. This also includes the through testing of baseband amplifiers, switching equipment, and interconnecting cables, where the traffic signal occupies a frequency spectrum in the approximate range 25 Hz to 8 MHz,

† Telecommunications Development Department, Telecommunications Headquarters.

To describe the principles of testing, a broadband radio-link system may be considered to be of the form shown in Fig. 1. Minor links (one or two broadband channels) will have some of the sections omitted. Major links (six to eight broadband channels) will have more than one standby or protection channel with consequently more complex i.f. switching; however, the five categories of testing will still apply.

## OVERALL TESTING

### Tests for Intermodulation Distortion

The most important test for both multichannel telephony and multiplexed data is for intermodulation and white noise testing techniques are used.<sup>3</sup> In this test, a band of random noise, extending over a frequency range normally occupied by the traffic signal, is fed into the link at a level simulating the normal loading of the broadband channel under test. By means of a narrow band-stop filter, the noise may be reduced in one narrow band giving the effect of one quiet telephone channel. At the receiving end of the link, a selective receiver is used to measure the noise level in this quiet channel and compare it with the noise in the same channel with the stop filter removed. If intermodulation products are present, the noise power ratio in the quiet

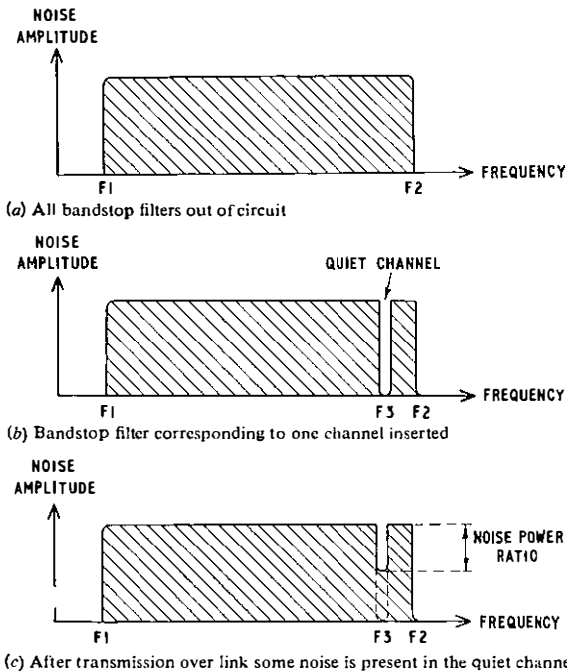

FIG. 2—Sketches showing the degree of intermodulation noise

channel (illustrated in Fig. 2), will be different from the known insertion loss of the band-stop filter, and the degree of intermodulation can be determined.

The test set is shown in Fig. 3. The noise bandwidth is determined by means of a high-pass filter, F1, followed by a low-pass filter, F2. The latter is usually interchangeable

to cater for different capacity systems, for example a 600-channel system would be tested with a noise bandwidth from 60 kHz to 2,540 kHz. The set-level control, A1, determines the loading applied to the system and it is usual to apply a level of noise corresponding to the average level of signal to be found on the telephony baseband during the busy-hour period.

Initially, the band-stop filters, F3, are switched out and, at the receive end, the set-level attenuator, A2, is adjusted to produce a reference level reading on the receive indicating meter, the lower-frequency band-pass filter, F4, being in circuit. The band-stop filter, F3, is then switched in at the transmit end and the lower-frequency band-pass filter, F4, selected at the receive end. The receive indicating meter reading is then brought back to reference level by reducing the attenuator, A3. If there were no noise generated in the radio system under test, the reduction required would equal the insertion loss of the band-stop filter, F3. However, in a practical case there will be noise present in the quiet channel, from thermal noise generated by the radio system and intermodulation products of noise components injected by the test equipment in the band either side of the narrow stop band. The reduction required in the attenuator, A3, to bring the receive indicating meter back to the reference level is called the *noise power ratio* (n.p.r.) and is used to denote the quality of the system for handling telephony traffic.

The value of the n.p.r. will vary both as a function of the level of noise loading applied to the system input, and of the position in frequency of the narrow band in which the measurement is made. It is, therefore, insufficient simply to express the n.p.r. at one particular loading and frequency to determine the system capability for handling telephony, and it is usual to plot a graph of n.p.r. against input-noise loading-level for a series of stop-band frequencies and at various noise loading levels. However, once the system's white noise characteristic is known it is only necessary for maintenance purposes to measure at, say, three frequencies at normal busy-hour loading level to observe and correct any degradation which may have taken place between successive tests. It is also necessary to measure the basic noise produced by the system at each of these frequencies. This can be done by measuring as described above but removing the input noise signal completely, instead of only one small band.

If a graph is plotted of n.p.r. against input loading level, at several frequencies, it will take the form shown in Fig. 4. As the input loading is increased, the system deviation will increase and since the basic noise remains low and constant, the n.p.r. increases proportionally, up to a point. Beyond this, the higher level components of the input noise are driven into the non-linear regions of the modulator and demodulator transfer

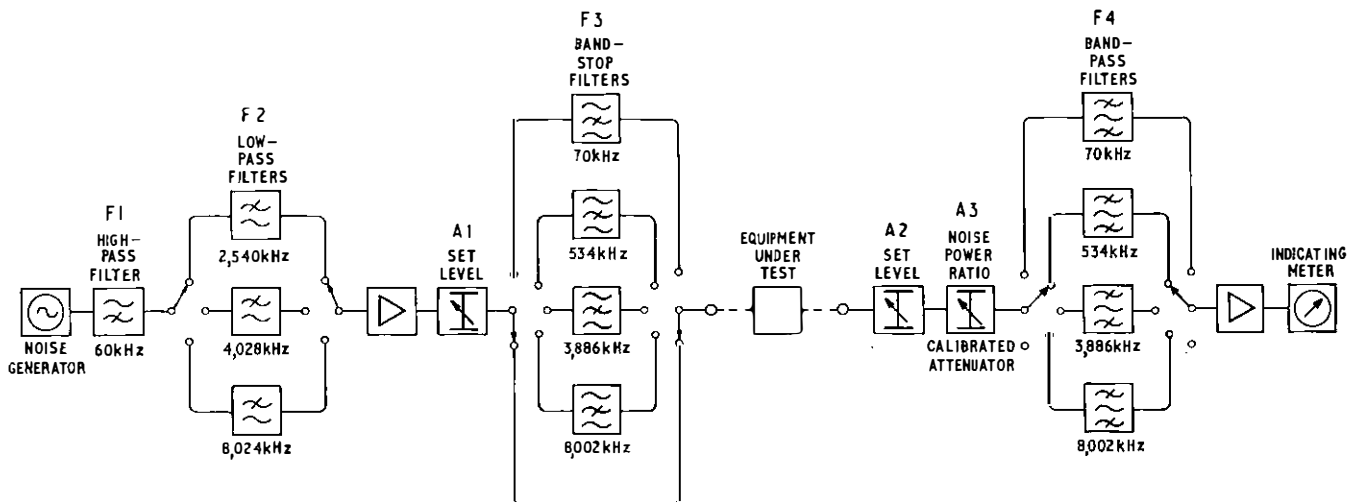

FIG. 3—Block diagram of the white-noise test-set

characteristics, hence causing intermodulation to take place.

As the input level approaches the overload point of the system, the intermodulation noise completely swamps the basic noise, causing the response curve to drop away steeply. It will be seen that there is an optimum value for the system deviation which gives the best compromise between basic and intermodulation noise (i.e. the peak of the graph), and also that the value of the n.p.r. decreases as the stop-band frequency chosen moves up the baseband frequency spectrum, for a given loading level. This is because the noise produced in the quiet channel at the lower end of the baseband consists of mainly sum and difference products of the noise components, but at the high end of the baseband, sum, difference, and harmonic components are present to a greater degree.

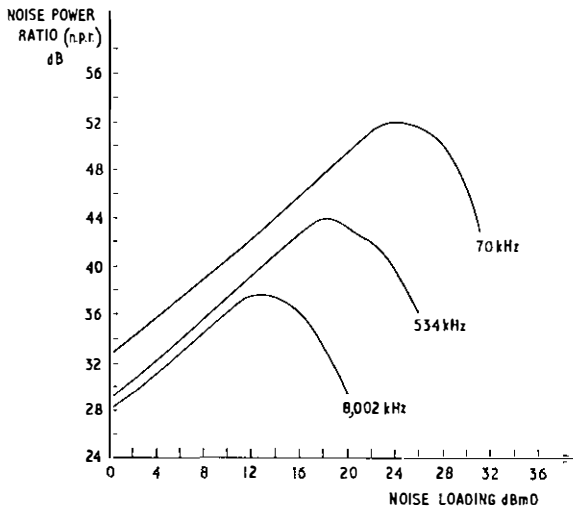

FIG. 4—Graph of noise power ratio against noise loading

The system parameters which affect the white noise characteristics are non-linearity in the modulator and demodulator transfer characteristics and group-delay distortion in the i.f. and radio frequency (r.f.) sections of the radio link. It can be said as a general guiding rule that the n.p.r. at the lower baseband frequencies is largely governed by the non-linearity of the system, and at the higher baseband frequencies, by the group-delay characteristic of the system. It is difficult, however, in practice to adjust both linearity and group-delay controls on a radio system to obtain optimum performance by using the white noise test-set as these adjustments are to some extent interdependent. If some fault is suspected which affects these parameters, it is necessary to measure and adjust linearity and group-delay separately using other equipment before applying white noise tests.

### Tests for Spurious Noise

The next most important overall baseband test is to search the baseband output with a selective measuring set, with no input signal to the system, for spurious or interfering single frequency signals. It is known that varactor-diode frequency multiplying chains, often found in broadband radio system transmitters and receivers, can, under fault conditions, produce high, level spurious signals which may appear in the baseband. These may lie between the test frequencies of the white noise test-set, and can seriously interfere with traffic on the system. If a spurious signal, whose level exceeds the permitted value for the particular system under test, is found the section in which the signal is produced can be localized using test demodulators which enable a baseband signal to be obtained at intermediate points along the link. The oscillator multiplier chains in this section are then substituted until the faulty unit is found.

Other baseband tests include static gain/frequency response and return, loss measurements. These are useful when investi-

gating the performance of individual baseband amplifiers, filters, and switching equipment, rather than the entire radio link.

### TESTING OF MODULATING AND DEMODULATING EQUIPMENT

The modulator of a broadband radio system accepts the baseband signal and frequency modulates a carrier frequency of 70 MHz. The demodulator performs the reverse function, and enables the original baseband signal to be recovered.

#### Linearity Testing

It is usual to test a demodulator first, and after correcting any deficiencies, to use this demodulator to test one or more modulators, the most important test being to check the linearity using the derivative method. Several types of test set called derivative test-sets are in general use, but the general principles are the same.

The derivative send-unit produces a signal consisting of a low-frequency sine wave (of the order of 50 to 70 Hz) with a higher frequency sine wave (of the order of 20 to 100 kHz) superimposed upon it. The amplitude of the lower frequency wave is approximately ten times that of the higher frequency wave as shown in Fig. 5. This signal is used to frequency

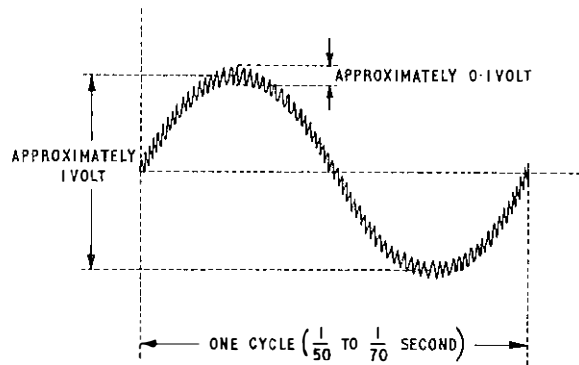

FIG. 5—Signal output from the derivative send-unit

modulate a carrier frequency oscillator whose centre frequency may be shifted over the i.f. band of approximately 50 to 90 MHz. The deviation may be adjusted so that the lower frequency sine wave sweeps out a deviation of the order of 10 MHz peak-to-peak which is the bandwidth over which the demodulator is required to have a high degree of linearity. The demodulator's transfer characteristic will have the form shown in Fig. 6.

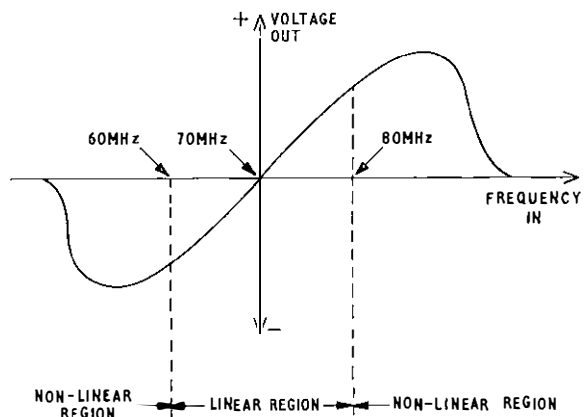

FIG. 6—Demodulator transfer characteristic

If the frequency-modulated signal is applied to the demodulator, then the amplitude of the higher-frequency sine wave output will be constant over the linear region, and vary in

amplitude over the non-linear region of the transfer characteristic. Thus, the degree of non-linearity can be measured as the variation of this higher-frequency sine wave over the cyclic variation of the lower-frequency sine wave. The receive unit of the derivative test-set amplifies, rectifies, and displays the amplitude of this higher frequency sine wave as the Y deflexion on a cathode ray tube whilst the lower frequency sine wave constitutes the X deflexion.

A typical display of the derivative response for a good demodulator is shown in Fig. 7. In practice, however, the dis-

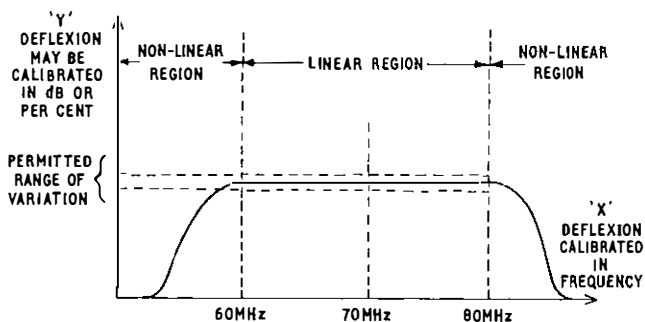

FIG. 7—Demodulator derivative characteristic

play is seldom level over the desired region and limits are laid down for the acceptable amount of variation permitted for the particular type of demodulator.

Controls are normally provided on the demodulator to adjust the linearity and, when these have been optimized, the demodulator can be used to test a modulator. For this test the waveform shown in Fig. 5 is applied directly to the baseband input of the modulator, the i.f. output of the modulator is connected to the i.f. input of the demodulator, and the baseband output of the demodulator is connected to the display-unit input.

The displayed response will be the total derivative response of the modulator-demodulator pair and hence, its departure from that of the demodulator on its own gives the modulator's derivative response. Controls provided on the modulator enable the response to be optimized, and again limits are laid down for the degree of non-linearity permissible. It is very important that the demodulator is not re-adjusted for linearity to compensate for any non-linearity in the modulator, since this would prevent either modulator or demodulator working to any other demodulator or modulator, an essential requirement on systems which use i.f. switching.

### Other Tests

In addition to linearity tests, the modulator and demodulator are tested for return loss at both baseband and i.f. points to ensure that a correct impedance match is obtained between them and other equipment to which they are connected, controls often being provided to optimize the performance in this respect. It is also necessary to check the deviation sensitivity and i.f. output level of the modulators, and output level (for correct deviation input) of the demodulators.

### TESTING OF LINK SECTIONS BETWEEN I.F. POINTS

The two most important tests under this heading are i.f. amplitude/frequency response and i.f. group-delay/frequency response.

#### I.F. Amplitude/Frequency Response

The i.f. amplitude/frequency response gives the variations in loss and gain over the i.f. band (typically 60 to 80 MHz) and hence, variations in the i.f. amplitude/frequency response will cause variations in the baseband gain/frequency response. For example, an i.f. amplitude/frequency response which is of domed shape (i.e. falling off in gain at the 60 MHz and

80 MHz points with respect to 70 MHz) will give a baseband amplitude/frequency response which falls off at the higher frequencies. Similarly, an i.f. amplitude/frequency response which is of double-humped shape (i.e. rising at the 60 MHz and 80 MHz points with respect to 70 MHz) will give a baseband amplitude/frequency response which rises with increasing baseband frequency.

#### I.F. Group-Delay/Frequency Response

The i.f. group-delay/frequency response is indicative of the variation in the rate of change of phase with frequency over the intermediate frequency band.

The group-delay/frequency response as measured on an i.f. to i.f. section of a radio link usually takes the form of a wavy line (Fig. 8(a)) and it is necessary to analyse this by inspection into three types of curvature as illustrated in Fig. 8. Group-

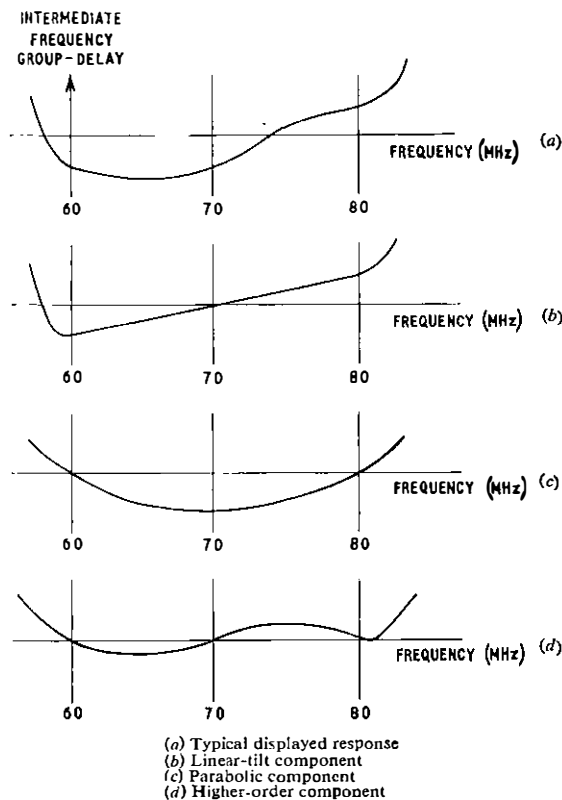

FIG. 8—Group-delay/frequency response

delay equalizers are usually provided in the i.f. sections of the link to correct linear tilt (Fig. 8(b)) and parabolic components (Fig. 8(c)). The higher order components, being of smaller amplitude and of less importance, are tolerated (Fig. 8(d)).

It is usual to measure these link parameters by means of an i.f. amplitude and group-delay scanner which gives a dynamic display on a cathode ray tube of i.f. amplitude/frequency response, or i.f. group-delay/frequency response, or both simultaneously, on later equipments.

#### I.F. Amplitude and Group-delay Scanner

The scanner consists of two main parts, the signal generator unit, and the display unit. These two parts may be physically separate units which have to be connected together to make up a complete item.

The signal generator, Fig. 9, consists of a carrier generator and frequency modulator which produces a carrier frequency (70 MHz) modulated by two separate oscillators. One oscillator operates at 70 Hz and produces a fairly wide deviation (typically  $\pm 10$  MHz), the other, causes a deviation of about 200 kHz. This complex signal is fed into the i.f. section to be tested, via an amplifier and a limiter to remove

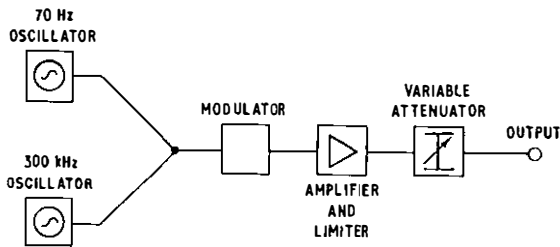

FIG. 9—I.F. amplitude and group-delay scanner signal generator-unit

any amplitude variations produced by the testing modulator itself, and via an attenuator to set the i.f. level correctly for the section under test.

The display unit, when performing i.f. amplitude tests (Fig. 10) consists of a detector and a discriminator. The

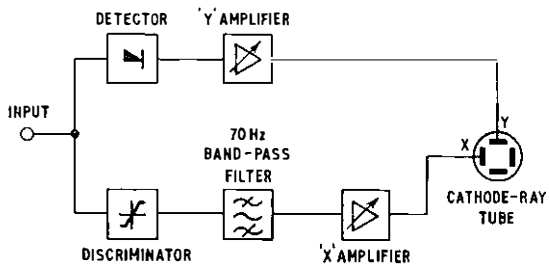

FIG. 10—I.F. amplitude scanner display unit

detector provides a voltage proportional to the i.f. level and is connected to the Y plates of the cathode ray tube (c.r.t.). The discriminator provides the 70 Hz sweep-signal and the display time-base. Hence, the display will be that of the amplitude/frequency response since the frequency at any instant depends upon the amplitude of the 70 Hz signal applied to the modulator in the signal generator.

The scanner is provided with means for calibrating the display in terms of amplitude and frequency, and a typical response would be within 0.5 dB between 60 MHz and 80 MHz with respect to the level at 70 MHz.

When performing group-delay tests, the display unit takes the form shown in Fig. 11. The input signal is applied to the

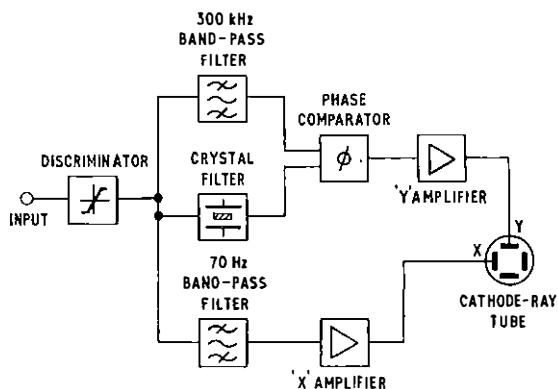

FIG. 11—Group-delay scanner display unit

discriminator from which there will be two outputs, the 70 Hz sweeping signal of large amplitude, and the 300 kHz signal of small amplitude. If group-delay distortion is present the phase of the 300 kHz signal will vary over each cycle of the 70 Hz signal and it is possible to compare the variation in phase with a reference 300 kHz signal whose frequency and phase remain constant. This reference signal can be derived from the signal to be measured by means of a crystal filter whose bandwidth is so narrow that its output can be regarded as equivalent to a crystal oscillator, but which has the advantage of remain-

ing synchronized to the incoming 300 kHz signal over each cycle of the 70 Hz sweeping signal.

Instantaneous variations in phase will pass via the 300 kHz band-pass filter into the phase comparator where they are compared with the reference signal from the crystal filter. The phase comparator produces a signal which is proportional to the phase angle between the two input signals and hence is a measure of group-delay over any 70 Hz period. This signal is applied via the Y amplifier to the c.r.t. and the X deflection obtained as before from the 70 Hz signal. Means are provided for calibrating the display by inserting a known amount of delay into the reference signal path and calibrating the c.r.t. graticule.

Other methods of measuring group-delay are in current usage but the general principle described still applies. The other methods differ in the way in which the reference signal is obtained. It is usual to provide an equalizer to correct the parabolic component of group-delay at each radio receiver and a group-delay tilt equalizer, in addition, at the terminal receiver before the i.f. switching or demodulating equipment.

An important source of group-delay distortion in earlier radio links was due to impedance mismatches and reflexions in the aerial and feeder arrangements, but this has been considerably reduced in later systems by the widespread use of ferrite isolators. A further source of distortion arises from multi-path propagation effects along the path of the radio link, and to a smaller degree distortion is introduced by the i.f. amplifiers associated with each receiver. This latter distortion is variable in degree, the variation being caused by the change in gain and response of the receiver i.f. amplifiers as their automatic gain control systems compensate for fading on the link.

The effect of i.f. group-delay distortion on the baseband signal, is to produce intermodulation distortion at the higher baseband frequencies for multi-channel telephony, and to produce differential phase distortion on colour television transmissions. Typical maintenance limits for group-delay are of the order of 2 ns over the band 61 MHz to 79 MHz, for each i.f. section of the link, and within 5 ns over a long multi-hop link between modulator output and demodulator input.

### Other Tests

Other tests performed over i.f. sections are; input and output impedance measurements on i.f. amplifiers, limiters, and other panels carrying i.f. signals, and examination of the i.f. band spectrum for interfering spurious signals by means of a spectrum analyzer.

## U.H.F. AND S.H.F. TESTING

### Amplitude/Frequency Response of Transmitters

The amplitude/frequency response of a transmitter is usually measured by means of a crystal detector mounted in the transmitter waveguide or coaxial cable output. The crystal detector is normally built into the transmitter and the d.c. output used to operate a meter calibrated in watts (r.f. power). If the transmit frequency changer, where the i.f. signal is converted to u.h.f. or s.h.f., is fed with the swept i.f. signal from the generator previously described, the transmitter output frequency will also sweep over the band normally occupied by the signal, and the instantaneous d.c. output from the crystal detector will be proportional to the r.f. power output at each instantaneous frequency point.

This d.c. output can be taken directly to the Y amplifier of the display unit and a display obtained of the u.h.f./s.h.f. amplitude/frequency response. As before, the display unit can be calibrated in terms of amplitude and frequency, the amplitude being in decibels relative to the u.h.f./s.h.f. power at centre frequency.

A typical response is within 1dB over the 60 MHz to 80 MHz range, relative to 70 MHz. If an abnormal response is obtained



the transmitter is connected to a dummy load (which is a resistive termination capable of dissipating ther.f. power and providing a perfect impedance match to the transmitter) and the response re-examined. If the response is found to be normal, a fault in the multiplexing filters, feeders or aerial system is probable, since such a fault, by producing reflexions, will cause ther.f. voltage to vary excessively with varying frequency.

If the response into the dummy load is found to be abnormal, the transmitter itself is at fault.

### Receiver Fading-Margin Tests

Tests are required to ensure that each receiver does not contribute to overall system noise by more than a specified amount. Such noise usually is due to the receiver frequency changer and early stages of i.f. amplification. The tests also ensure that the receiver will continue to operate under input signal fading conditions of about 30 dB relative to normal input level without excessively degrading the traffic signal.

To measure receiver fading-margin, a u.h.f./s.h.f. signal generator, previously tuned to the receiver's input frequency, is connected to the receiver input and its level adjusted so as to give the same input signal level as is normally obtained from the previous station.

The output i.f. of the main i.f. amplifier is connected to a suitable level measuring device, calibrated in dB relative to 0.5 volt, and the i.f. level noted. This is the reference i.f. level.

The input to the receiver is now reduced by means of the attenuator on the u.h.f./s.h.f. signal generator until the reference i.f. level falls by 3 dB. The change in the attenuator setting gives the fading margin and is normally greater than 30 dB. This test checks the correct operation of the automatic gain control system of the receiver.

### Aerial Feeder and Multiplexing-Filter Tests

Two types of test are usually performed on r.f. feeders and multiplexing components, insertion-loss/frequency response, and measurement of reflexions due to mismatch between components for aerials.

For the measurement of reflexions due to mismatch, two methods are in general use.

- (a) the slotted-line methods, for use at single frequencies, and
- (b) frequency-sweep methods for examination of reflexions over a band of frequencies.

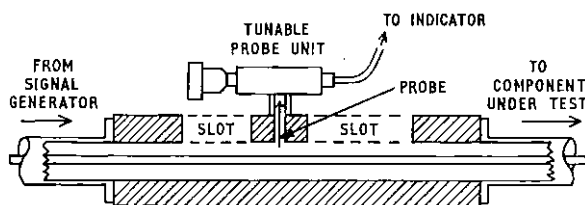

FIG. 12—Measurement of reflexions due to mismatch using the slotted-line method

The slotted line, Fig. 12, consists of a length of coaxial line (or waveguide) which has a longitudinal slot in its outer wall through which a probe may be inserted to couple with the electric field within the line. The slot also provides a means for moving the probe along the line in order to observe the minimum and maximum intensity of electric field over distances of several wavelengths on the line.

The line is inserted between a u.h.f./s.h.f. signal source and the component under test (e.g. an aerial feeder, terminated by a precision load). If the feeder were perfect, all the transmitted power would be absorbed by the terminating load, but in practice some power will be reflected due to mismatch conditions caused by feeder joints, imperfections in the feeder, or possible damage to the feeder. The resultant of the transmitted and reflected signals will cause a standing wave to

occur along the line and, by moving the probe, the points of voltage maxima and minima can be observed. The voltage can be measured at these points by means of a detector-amplifier-indicator, to which the probe is attached.

The parameter measured is called the voltage-standing-wave ratio (v.s.w.r.) and is the ratio of the voltage maximum to the voltage minimum as measured by the probe. By means of a calibration arrangement, the indicator may be arranged to give a direct read-out of v.s.w.r.

Values which must not be exceeded are usually given for the v.s.w.r. of aerials, feeders, and waveguide components. Where the performance over a band of frequencies is of interest, the measurement of v.s.w.r. is taken at a number of spot frequencies, and a graph plotted of v.s.w.r. against frequency.

As this process is rather tedious and time-consuming, frequency-sweep methods giving a graphic display on a cathode ray tube oscilloscope are now coming into more general use.

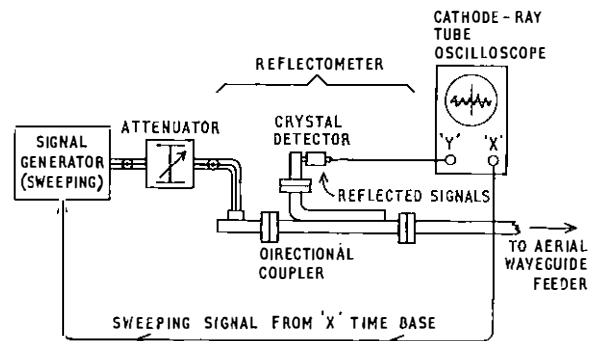

FIG. 13—Measurement of reflexions due to mismatch using the frequency-sweep method

The general arrangement is as shown in Fig. 13. The u.h.f./s.h.f. source is caused to sweep over the band of frequencies concerned, and the signal is passed to the feeder system via a reflectometer. This consists of a directional coupler and crystal diode detector so arranged that the reflected signal is diverted to the crystal detector which gives out a d.c. signal proportional to the amplitude of the reflexions returned from the feeder and aerial system. This signal may be displayed as the Y deflexion on an oscilloscope and the X deflexion follows the frequency sweep. The display can be calibrated in amplitude and frequency, and has the advantage over the slotted-line method in that the results of adjustments made to the aerial system, or waveguide components which affect the v.s.w.r. may be seen immediately.

### Radio-Path Propagation Tests

These tests are sometimes carried out on an existing radio link where either severe or unusual fading conditions have been observed or where trouble is being experienced by a suspected reflexion along the path (e.g. the erection of a large building or structure near the path).

The method used is to set up recording decibel meters at adjacent transmitters and receivers over each hop, the former to record transmitted power and the latter to record received signal level. Comparison of the two recorded charts will show the variation in path attenuation over the period of time for which the recorders are operating. The charts may be calibrated, at the transmit end by means of a u.h.f./s.h.f. power meter, and at the receive end by means of a u.h.f./s.h.f. signal generator (calibrating the receiver a.g.c. voltage against input signal level), and arranging the recorder to read variations in a.g.c. line voltage.

### TESTING OF AUXILIARY AND MISCELLANEOUS EQUIPMENT

Other tests performed on broadband radio systems, as opposed to individual broadband channels are mainly functional tests associated with the supervisory, control, and

switching equipment. It is usual to transmit supervisory and control signals, for performing switching operations, and giving remote indications of alarms at unattended stations, over a separate radio link. Most of the tests described apply also to these links, which are of narrower bandwidth than the main broadband channels, but are similar in type.

The supervisory and control signals are in the form of voice-frequency tones, and in addition, one or two audio speech channels are provided for engineering speakers between radio stations along the link. The normal tests applicable to carrier and audio-frequency transmission, therefore, also apply to these supervisory radio links.

Coaxial and waveguide feeders, and horn aerials are pressurized with dry air to exclude moisture and prevent condensation with subsequent corrosion of the waveguide surfaces. Tests are performed on the pressurizing and dehumidifying equipment to check pressure, humidity, and air flow, and to verify the correct performance of the equipment.

## CONCLUSION

The general principles of testing used to maintain broadband radio links at their required standard of performance have been described. In the future the testing principles are likely to stay the same but the testers will become automatic with lamp displays indicating faults.

## ACKNOWLEDGEMENT

The assistance of colleagues in the Post Office Telecommunications Headquarters Departments in the preparation of this article is acknowledged.

## References

<sup>1</sup> MCDIARMID, I. F. Waveform Distortion in Television Links. *P.O.E.E.J.*, Vol. 52, pp. 108 and 188, July and Oct. 1959.

<sup>2</sup> TANNER, R. K. R. Testing 625-line Monochrome and Colour Television Transmission System, Pt 1. *P.O.E.E.J.*, Vol 58, p. 126, July 1965.

<sup>3</sup> WHITE, R. W. and WHYTE, J. S. Equipment for Measurement of Inter-Channel Crosstalk and Noise on Broadband Multi-Channel Telephone Systems. *P.O.E.E.J.*, Vol 48, p. 127, Oct 1955.

---

## Book Reviews

"Telephony and Telegraphy A." Sydney F. Smith, B.Sc. (Eng.), C. Eng., M.I.E.E. Oxford University Press. xv + 285 pp. 243 ill. 42s.

This book has been written to provide, in one volume, a complete coverage of both the telephone and telegraph aspects of the present (1970) syllabus of the City and Guilds of London Institute examination in Telephony and Telegraphy A. It is intended primarily to be a book for students and it fulfills this purpose admirably.

The author is a Senior Lecturer in Telecommunications, and he has used his lecture notes as his main source of information. He acknowledges that very little of the information is original and previously unpublished, but he has sought a new presentation which would best meet the needs of his intended readers.

The City and Guilds syllabus is given at the beginning of the book and the author's interpretation of it is good.

The telephony and telegraphy aspects of each topic are dealt with in the same chapter. Each chapter is divided into five parts: 1—Introduction, 2—Principles, 3—Practical Apparatus, 4—Summary, and 5—Self Teaching Notes and Exercises. A student who has experience in some related field can thus pick out the sections which he needs to read. The summary is particularly useful for revision purposes. The Exercises consist of approximately 20 questions needing only very short answers followed by three or four past City and Guilds examination questions; the answers are given at the end of the book. The longer answers are given in the form of guide notes, not model answers, and thus the student is not given any guidance on how to set out an answer.

No photographs are used in the book; the author has used line drawings so that he could present detail more selectively. This is good in most respects, but a few photographs, e.g. of a teleprinter mechanism in chapter one and a selector mechanism in chapter five, would have been appreciated. The circuit elements are drawn to BS 3939 and are good.

Several times in the book the student is referred to page XIII. It is unfortunate that the printers neglected to number this page.

The book has a stiff paper cover, and whilst the initial

visual impact is poor the text is excellent. It is fully recommended to any student taking the City and Guilds examination in Telephony and Telegraphy A and any other student wishing to gain an insight into the established techniques of basic telephony and telegraphy.

A. P.

"Radio and Line Transmission," Vol. 3. G. L. Danielson and R. S. Walker. Butterworth and Co., Ltd. 308 pp. 181 ill. 25s.

As the authors state in their summary, the book has been specially written for students taking the Telecommunication Technicians' Certificate examination in Communication Radio C, of the City and Guilds of London Institute, and assumes that they have a knowledge of the subject matter contained in the previous two volumes. These cover the Radio and Line Transmission A and B syllabuses.

A good attempt has been made to provide a self-tutored course in the form of a medium-priced book of reasonable size. The subject matter is divided into a large number of sections which are clearly described by main headings and sub-headings. Worked examples are numerous, and at the end of each main section several questions are set. Numerical answers to all questions are given at the end of the book. The authors style of writing is lucid and concise.

Both valve circuits and transistor circuits have been included in the book. This is to take into account the fact that some circuits can be used at either low or high power levels. At low levels, transistors are invariably used, but at high power levels such as are encountered on long and medium wave transmission, it is necessary to use valves because transistors cannot handle such large powers.

As regards the presentation, the type-face is bold and easy to read, and the varitype symbols, subscripts and indices are especially good for a book of this price. All illustrations are line drawings, which are reproduced very clearly.

The book is recommended for City and Guilds students and could also be of considerable use to those taking H.N.C. and professional examinations which include radio communication.

J. F.

# Programmable Logic—A New Approach to Standardization

C. J. HUGHES, M.SC., C.ENG., M.I.E.E., and W. G. T. JONES, B.SC., C.ENG., M.I.E.E.†

U.D.C. 681.3: 16: 389.6

*Standardization of equipment has many advantages but the use of a standard sub-assembly that can easily be adapted to carry out different functions is usually ruled out on economic grounds. Larger-scale integration has necessitated standardization at a higher level so that the large development costs can be spread over long production runs. A simple, microelectronic, digital computer is described which allows standardization over a wide range of functions merely by changing one of the four integrated-circuit packages used. By so doing, the computer can be made to carry out the logic functions of, for example, almost any type of relay-set.*

## INTRODUCTION

In the Post Office, as in most user and operating organizations, standardization at all levels is very much worth while. With standardized equipment, less capital is tied up in spares held for maintenance purposes, documentation is simplified and the number of specialized training courses that have to be held for maintenance staff is reduced. On the manufacturing side, standardization means longer production runs so that production lines can be organized more efficiently and test and inspection procedures stabilized.

At the component level, standardization is well established. For example, the wipers of 2000-type selectors are interchangeable and it is not necessary to refer to the original manufacturer when carrying out maintenance replacements. Similarly, a transistor having a CV number is made to a standard specification and is completely interchangeable with a transistor having the same number made by another manufacturer.

When it comes to sub-assemblies, the first departures from standardization become necessary on economic grounds. Thus, the stepping mechanism of a 2000-type selector is largely standardized but different wiper carriages and guide rods are necessary to cope with different types of selector banks. At a higher level of sub-assembly, even greater departures from standardization occur. Taken as a complete unit, a 200-outlet final selector with p.b.x. facilities is very different from the A-digit selector in a director exchange. Of course, a 2000-type A-digit selector is largely standardized and it is possible to remove a selector from one exchange and to jack in the unit in the A-digit selector racks of another exchange. Standardization has been achieved but only for one function at a time. In theory, it would be possible to design a single unit that would carry out both the final-selector and the A-digit selector functions with, say, a plug-in wired card being used to change from one function to the other. Such an approach would involve many redundant relays and wiring connexions, which would completely outweigh any advantages resulting from standardization.

It is clear, then, that although standardization is feasible where the unit is used for a single function, it is very much more difficult to justify standardization over a range of functions. Even if the functions are very similar, as with signalling relay-sets, it is not often justifiable to use a relay-set having an extended range of facilities in situations where only some of the facilities are required. For this reason, there are several hundred different types of relay-set in use in the Strowger network.

Similar considerations apply in the electronics field. A v.f. receiver contains an audio-frequency amplifier that might be used as a channel amplifier in a carrier terminal-equipment. This would permit a greater degree of standardization, but when used as a channel amplifier, the detection and guard circuits would be redundant. The extra cost of providing the additional circuitry in the channel amplifier far outweighs the savings resulting from standardization.

## DIGITAL COMPUTERS

It is interesting to note that one of the outstanding examples of standardization occurs in the mechanical and electronic aids that are used for performing calculations. Experience has shown that even the most complex calculations can be broken down into a series of relatively simple, discrete steps. The mechanical aids to calculations such as the abacus, the slide rule, and the desk calculator have been constructed to carry out these fundamental operations and they can thus be used in many different types of calculation. In more recent years, the versatility of the digital computer has come to be recognized. The earliest machines were constructed to carry out only one type of calculation, but it was soon realized that, by using a program contained in a store whose contents could easily be altered, a standard type of machine could perform a very wide range of calculations. The computer can be used to perform payroll calculations and then by changing the program, the same machine can be used for solving differential equations. Of course, if it were required to carry out only payroll calculations a much simpler machine could be used, so that the general-purpose machine can be regarded as having a high degree of redundancy when it is used for one particular purpose. Nevertheless, this redundancy is justified since most computers are used for several different types of calculation. Moreover, manufacturing costs are so much reduced by having standard ranges of computers that even greater savings are achieved by the stored-program approach.

## PROGRAMMABLE LOGIC IN MICROELECTRONICS

In the field of microelectronics, the general principles of standardization also apply, but it is debatable whether a micro-circuit such as a logic gate or a toggle should be regarded as a component or a sub-assembly. The economic forces, however, make standardization even more worth while than for discrete components since silicon integrated circuits (s.i.c.) are very cheap when produced in large quantities. A toggle unit, for example, may be appreciably more elaborate than necessary in most applications but the redundancy is justified since the relatively complicated toggle unit shown in Fig. 1 (b) costs very little more to manufacture than the simpler

† Research Department, Telecommunications Headquarters.

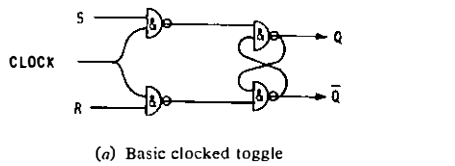

(a) Basic clocked toggle

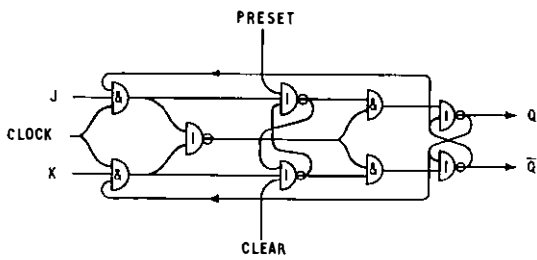

(b) Typical integrated-circuit toggle unit

FIG. 1—Toggle units

unit shown in Fig. 1 (a). Even in the early days of microelectronics, it was obvious that if simple gates and toggles could be produced cheaply in the form of an s.i.c., then it should be possible to produce more elaborate logic arrays in a similar fashion. This came to be known as larger-scale integration (l.s.i.). There were, of course, some difficulties in that the more elaborate the logic, the greater was the area of silicon occupied and therefore it was more likely that the unit would be faulty. Metal oxide semi-conductor (m.o.s.)<sup>1</sup> techniques have helped to overcome that problem and it is now possible to produce logic arrays having a complexity equivalent to several hundred logic gates on a single chip of silicon.

The difficulty in applying l.s.i. techniques to a large number of logic situations lies in the relatively high design costs. Each diffusion and metallization area on the chip has to be laid out very carefully to conform to established design rules and even the smallest error often means that a new set of masks has to be produced. For a simple gate or toggle device, these high design costs do not matter since the applications are so wide that several million devices may be produced to the same design. With a more complex logic array, the field of application becomes more restricted. The design costs are, therefore, spread over a smaller production volume, and unless the higher design costs can be offset by lower production costs, the use of an l.s.i. device is not justified.

For this reason, most of the l.s.i. units that have been produced so far have been designed to have a relatively wide field of application. Examples are binary adders and shift registers; one of the earliest examples of programmable logic was the programmable shift-register. The logic gates of the shift-register shown in Fig. 2 are arranged so that the signals are delayed by 4, 5, 6 or 7 clock intervals, the delay depending on the steady potentials applied to the program leads, A and B. If 4-bit, 5-bit, 6-bit and 7-bit shift registers are required in an equipment, only one programmable device is required for all the applications. Where the design calls for a 4-bit shift register, less than half the chip is used but the redundancy is justified since only one design is required and only one type of device need be held in stock for maintenance replacement.

A simple programmable shift-register is obviously limited in its application and some thought has been given to the possibility of extending the principle to other logic configurations. The general approach is to design a logic system on one or more chips so that it can be used for a wide variety of logic situations. The general-purpose logic is then adapted for use in a particular situation by an additional chip designed for that particular situation. If the general-purpose chips are

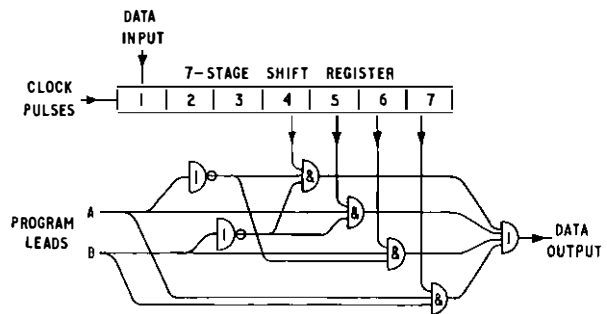

FIG. 2—Programmable shift-register

sufficiently adaptable, they can be produced very cheaply since the design costs are spread over a large production volume. The special-purpose chip may be more expensive since it is used in only one type of application, but if the design of this chip is kept simple, an overall saving may well be achieved.

This line of reasoning is similar to the reasoning that led to the design of the stored-program digital computers mentioned earlier, but the motive is different. The digital computer was designed so that the same machine could be used to perform a wide variety of calculations at different times, whereas the programmable-logic approach is adopted because of the economic factors involved in larger-scale integration. The use of a single, standardized logic-configuration for a wide variety of logic functions is justified even though there is a considerable degree of redundancy when the l.s.i. chips are performing any individual function.

## APPLICATION OF PROGRAMMABLE LOGIC—THE MINI-PROCESSOR

The approach adopted for l.s.i. programmable logic thus leads to a very simple stored-program computer, an arrangement which has become known as a mini-processor. A simplified block diagram is shown in Fig. 3, and it is seen that, unlike most stored-program computers, there is no general-purpose store; the program is held in an m.o.s. read-only memory. This is the unit which defines the function performed by a particular mini-processor, the remaining logic being standard for all applications. The program, of up to 256 words, each of 8 bits, is written into the memory during manufacture and cannot subsequently be changed. The memory pattern defining the program, however, is determined by

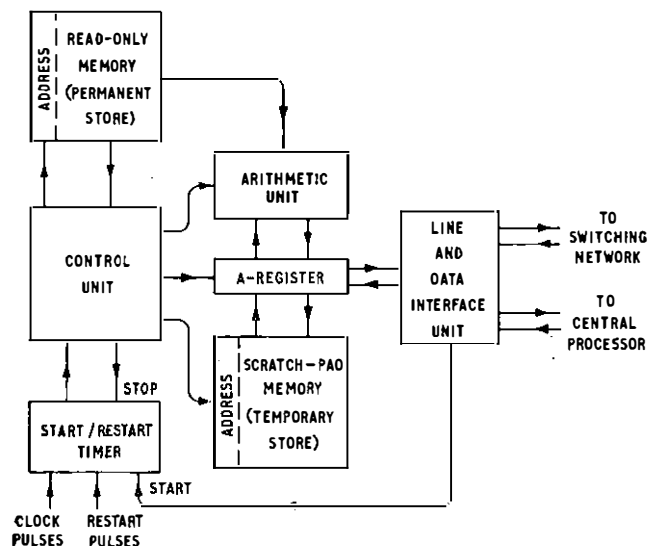

FIG. 3—Block diagram of mini-processor

only one of the m.o.s. processing masks, and it is thus economic to produce a small quantity of memory units of a particular type. If it is required to change the function performed by a mini-processor, the read-only memory must be removed and replaced with one of a different type. Mini-processors held as spares would thus be kept without read-only memories, and would be able to perform any required function on the addition of the appropriate program.

A small scratch-pad memory\* serves as the working store. The use of m.o.s. circuits for both storage and logic avoids the problem in many digital computers of associating high-speed logic with a relatively slow-acting core-store. The arithmetic and control units are simplified versions of the corresponding units in a conventional digital computer. The A-register is used to store the 8-bit data word being operated on, and its contents can be received from, or transmitted to, the arithmetic unit, the scratch-pad memory, the line-and-data-unit or, possibly, a more complex central processor. The line-and-data unit acts as the interface between the mini-processor and the external line.

The program is started by an external stimulus, such as a message from the data link or by a relay in the line unit applying a signal to the start-restart timer. The program is subsequently restarted automatically at pre-determined intervals until completed. The start-restart timer is then reset by an internally-generated signal which prevents automatic restarting until a further start pulse is received.

In many applications, the cycle time of each operation is sufficiently short to allow time-sharing between a number of channels. It is, therefore, possible to process simultaneously the information on eight external lines, thereby making the operation considerably more efficient. A separate scratch-pad memory and line unit are required for each line, the pair being selected by the start-restart timer. Investigations have shown that a single-channel mini-processor can be integrated into four l.s.i. chips, or packages. The start-restart timer is combined with the control unit to form one package, the A-register and arithmetic unit combined for the second, while the read-only memory and scratch-pad memory form the third and fourth. Multi-channel mini-processors will require one extra scratch-pad memory chip for each additional line.

### Construction

The complete mini-processor may be constructed on a small printed-wiring board as shown in Fig. 4. The conventional method of mounting integrated-circuit chips in TO5-type, flat-pack, or dual in-line packages is shown in Fig. 5 (a). The chip is mounted on a header and fine wires of gold or aluminium are used to connect the chip to the external-package leads. A lid is then placed over the chip and bonding leads, and hermetically sealed to the base. The disadvantages of this method are the difficulty of making good connexions with the fine bonding wire, and the number of interconnexions in series, i.e. chip to bonding lead, bonding lead to package lead, and package lead to printed-wiring board. Both factors can be sources of unreliability. It is also an expensive method of mounting since each bonding lead must be connected separately by an operator observing through a microscope, and the packages alone can be costly items where 24-lead and 44-lead devices are used.

To overcome some of these problems, the possibility of using the beam-lead<sup>2,3</sup> process is being examined. Two extra processing steps are introduced during circuit manufacture. Firstly, small bars of gold are formed around the edge of each chip on a wafer where external connexions are required. When the chips are separated, by etching from the back, the gold bars are left projecting as beams beyond the edge of the chip.

\* Scratch-pad memory—An area of read-write storage for temporary information used in the course of a program. The contents may readily be altered and the memory is small compared with the program store.

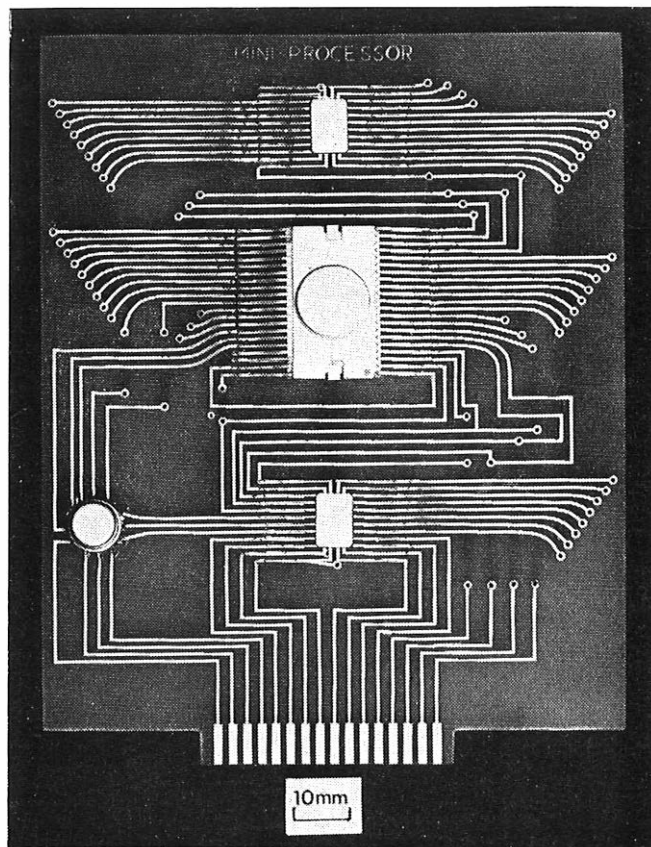

FIG. 4—Mini-processor constructed with conventional integrated-circuit packages

Secondly, the surface of the chip is passivated so that a subsequent hermetic seal is not necessary. The chips can then be mounted, face down, on a special circuit board, and all the beam-leads connected in one operation by a semi-automatic tool. The result is as shown in Fig. 5(b). This technique permits faster, cheaper, and more reliable mounting of integrated circuits, and would allow a complete 8-channel mini-processor to be mounted on a single board about 80 mm by 30 mm.

### Programming

The simplicity of the mini-processor is apparent from its limited instruction repertoire, as shown in Table 1. Each instruction is performed in one operating cycle and takes approximately 10 to 15  $\mu$ s depending on the rate of the externally-applied clock pulses. Typical applications in the telecommunications field are functions such as those performed by signalling relay-sets, pulse regenerators and dialled-digit receivers. When dealing with signalling rates of 10 pulses/s or less in these applications, the mini-processor would be arranged to sample the line state at intervals of typically 6 ms. It is this low sampling rate, compared to the processing speed, which allows a mini-processor to be time-shared. After the state of a particular line has been sampled, the appropriate processing can be completed in a sufficiently short time to allow several other lines to be sampled, and the information processed, before returning for a further sample of the first line.

The method of using the instruction repertoire is best illustrated by an example. Fig. 6 shows the flow chart for the detection and counting of dialled pulses at 10 pulses/s. The mini-processor is assumed to be operating in an exchange controlled by a large central processor with mini-processors connected to the periphery of the switching network. When a calling condition is detected, the switching network is set up to connect the calling subscriber to one of the line units of a mini-processor. The central processor then sends a message to

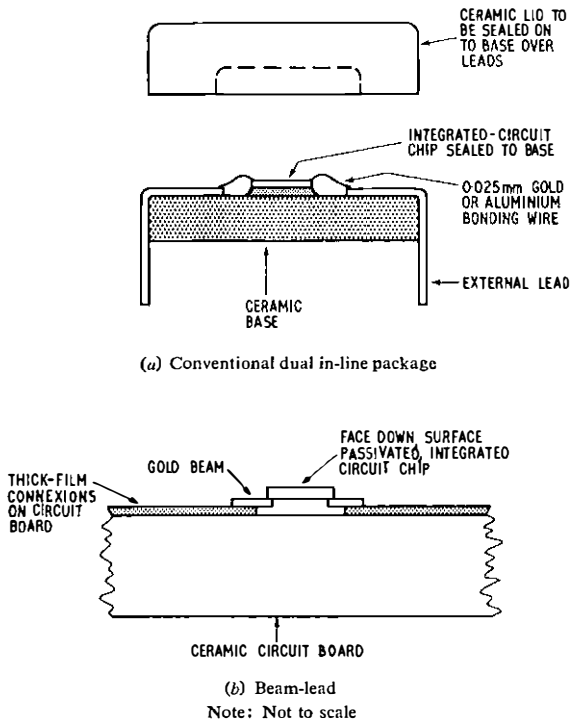

FIG. 5—Methods of mounting integrated-circuit chips

TABLE 1  
Mini-Processor Instruction Repertoire

No.	Mnemonic	Meaning
1	LDA	Load into A-register from line or data unit
2	OPA	Output from A-register to data unit
3	OPL	Output from A-register to line unit
4	CRA	Clear A-register
5	CRS	Clear scratch-pad location $S_n$
6	CYA	Copy into A-register the contents of scratch-pad location $S_n$ , $C(S_n)$ to remain unchanged
7	CYS	Copy into scratch-pad location $S_n$ from A-register. $C(A)$ to remain unchanged
8	CSS	Clear all scratch-pad locations in the first program run after a start pulse
9	JMP	Jump to $P_n$
10	JPL	Jump to $P_n$ if $C(A)$ positive
11	JMI	Jump to $P_n$ if $C(A)$ negative
12	JNZ	Jump to $P_n$ if $C(A)$ non-zero
13	ADD	Add $C(P_n)$ to $C(A)$
14	SUB	Subtract $C(P_n)$ from $C(A)$
15	STP	Stop at the next HLT instruction and do not restart until a further start pulse is received
16	HLT	Stop until a further start or restart condition is detected (but see STP)

Note:  $C(X)$  refers to the contents of  $X$   
 A = A-register  
 P = Read-only memory  
 S = Scratch-pad memory

the mini-processor indicating the channel to be operated on and giving a start pulse. The program is arranged to ignore the looped-line condition before dialling commences, and can detect valid dialled pulses in the presence of noise causing isolated line samples to be received incorrectly. A minimum total of eight break samples, or 48 ms, constitutes a valid dial break, and two make samples, or 12 ms, a valid make between breaks. A dialled digit is counted when a valid make follows a valid break. After dialled digits have been received, the detection of 16 successive make samples, equal to 96 ms of continuous make, indicates that the inter-digital pause has been reached. The mini-processor then transmits the dialled-digit count to the central processor as a data message. An STP instruction follows so that operations in that channel then

TABLE 2  
Part of Instruction Word List for Dialled-Digit Receiver Program

Program Word Number	Mnemonic	Address	Remarks
001	CSS	—	—
002	LDA	—	— ve = MAKE, +ve = BREAK
003	JPL	—	Jump if BREAK to location 034
004	—	$P_{034}$	} $M := M + 1$
005	CYA	$S_0$	
006	ADD	$P_{255}$	} $M = 16?$
007	CYS	$S_0$	
008	SUB	$P_{254}$	} Jump if $M \neq 16$ to location 015
009	JNZ	—	
010	—	$P_{015}$	} Output D via data-output unit
011	CYA	$S_2$	
012	OPA	—	} $B < 7?$
013	STP	—	
014	HLT	—	} Jump if $B < 7$ to location 027
015	CYA	$S_1$	
016	SUB	$P_{253}$	} —
017	JMI	—	
018	—	$P_{027}$	—

Notes: 1. Scratch-pad memory locations  
 $S_0$  = MAKE Count (M)  
 $S_1$  = BREAK Count (B)  
 $S_2$  = DIGIT Count (D)  
 2. Fixed-number locations  
 $P_{255} = 1$   
 $P_{254} = 16$   
 $P_{253} = 7$

cease until a start pulse is received from the central processor for the next digit.

Part of the list of instructions for the program is shown in Table 2.  $S_n$  refers to scratch-pad memory location  $n$  (e.g. the number of break samples counted ( $B$ ) is stored in  $S_1$ ).  $P_n$  refers similarly to a read-only memory location. Some of the locations at the end of the read-only memory can be used to hold fixed numbers for arithmetic operations; in this program, 1 is stored permanently in  $P_{255}$  and 16 in  $P_{254}$ . In Table 2, the program word number corresponds to the address of the read-only memory location in which it is stored.

In the flow-chart, the block after START or RESTART enables the scratch-pad memory to be cleared immediately after the start pulse. This removes any data which might remain from a previous call, and is done automatically in the mini-processor with the CSS instruction. In subsequent restarts, the CSS instruction will have no effect. The A-register is loaded with the line condition by an LDA instruction. The line unit is arranged to transfer to the A-register a data word of all logic 1 signals for a looped line, or make, and all logic 0 signals for a disconnected line, or break. A make is thus represented by a negative number, since the sign digit of the binary number will be a logic 1, and a break by a positive number. In the mini-processor, zero is a positive number since the sign digit as well as all the numerical digits are logic 0.

After determining the line state the program branches, the branch followed being decided by a JUMP IF POSITIVE or JPL instruction. If a break is present, the program jumps to program word 034 since that is the address contained in the program word after the JPL instruction. Since words of only 8 binary digits are used in the mini-processor, and a jump may be to any part of the program, the jump address must be contained in an additional word after the jump instruction. A make causes the program to continue in numerical sequence after the jump-address program word has been skipped. The number in the scratch-pad location containing the number of make samples counted is incremented by one (a fixed number stored in the read-only memory) and a branch follows depending on whether or not the resulting count has reached 16. This is done by subtracting 16 (stored in location  $P_{254}$ ) from the incremented make-count and initiating a jump if the result is not equal to zero. A zero result would cause the program to continue in numerical sequence. The subtraction is done

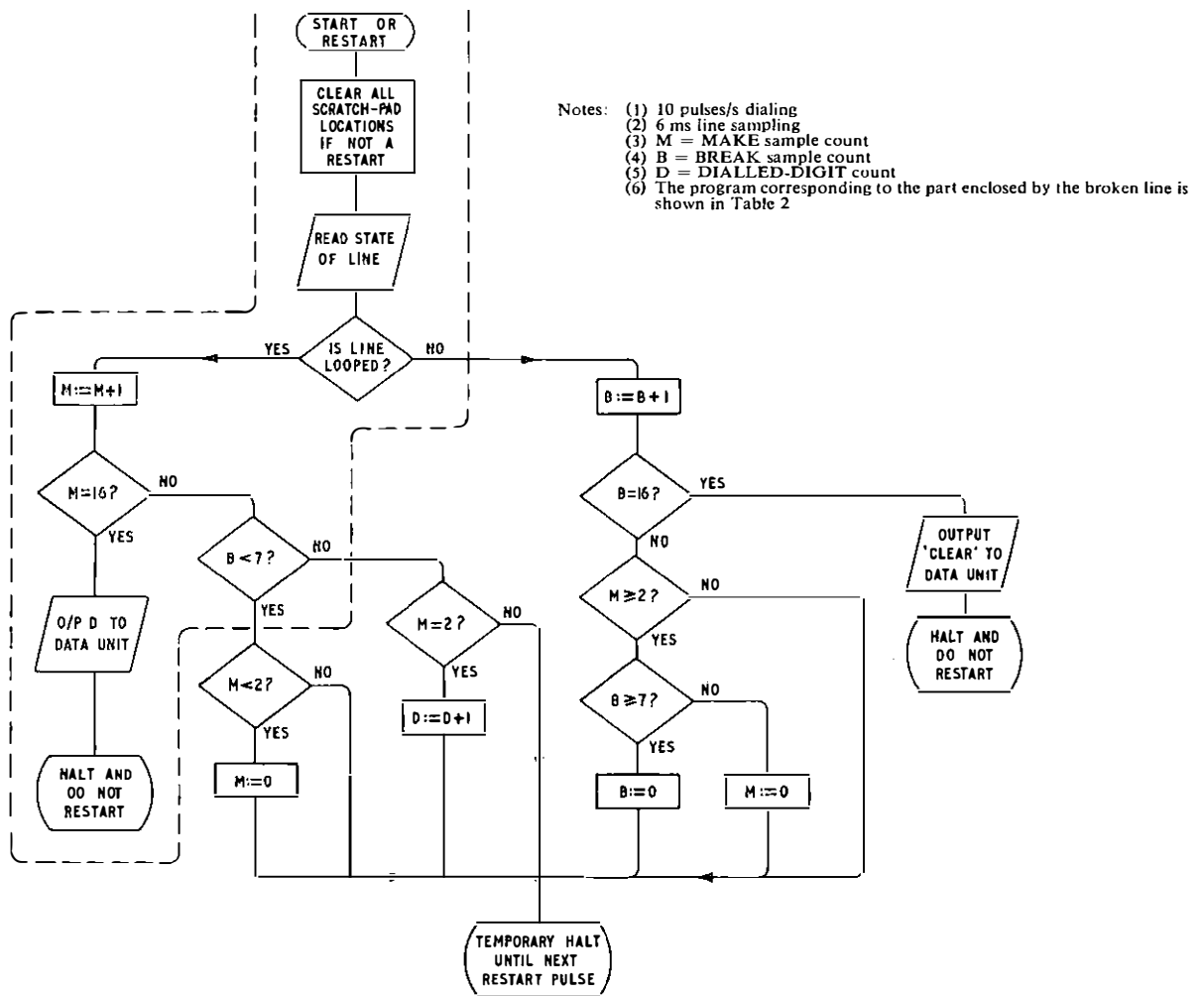

FIG. 6—Flow-chart of typical program. Detection and counting of dialled pulses

without destroying the make count as this was copied back into the scratch-pad location after incrementing by one. The remainder of the flow-chart is translated into program words in a similar manner.

The BREAK = 16 branch on the right-hand side of the flow-chart is used to stop the mini-processor if the subscriber should clear during dialling. Before stopping, the mini-processor sends a message to the central processor to allow the remainder of the equipment to be cleared. The mini-processor is thus performing a supervisory function as well as acting as a dialled-digit receiver.

The complete program uses 58 program words, including four fixed numbers. The longest path uses 19 program words and takes 200 to 300  $\mu$ s, thus easily allowing eight channels to be processed in 6 ms. Simple program changes would enable a mini-processor to deal with different make/break ratios, and alteration to the sampling rate would allow different dialling speeds to be accommodated.

### Advantages

The advantages of standardization at component and functional unit levels have been outlined above. The mini-processor approach leads to a very high level of standardization since the individual chips can be used in any mini-processor, and a mini-processor can be used as any functional unit, provided the appropriate read-only memory is attached. The individual chips of the mini-processor are very complex—several hundred logic gates in each chip and over 1,000 m.o.s.

transistors on some chips—but the large development costs can be spread over long production runs due to the number of functional units required. The read-only memory is specific to a particular type of functional unit, but the memories can be made economically in small quantities since only one production mask defines the memory pattern. Production testing is facilitated if only a few types of chip are involved, and a high degree of automatic testing is possible. Individual read-only memories can be tested by checking the program against the master tape used for mask production. For maintenance reasons the program units may be kept separate from the remaining logic, thereby allowing the latter to be mounted on a single card which could be returned to a central depot when faulty. It would be necessary to stock only a single type of replacement for the logic, whilst an alterable store, such as a ferrite-core store, loaded with the appropriate program and used in place of the read-only memory, would suffice until a replacement unit became available.

There are particular benefits when mini-processors are used in a computer-controlled exchange environment. The processes necessary to set up connexions through the switching network fall broadly into two categories. Firstly there are slow, simple functions which are repeated frequently, such as reception and interpretation of dial pulses; secondly, there are more complex functions which must be performed rapidly, but probably only once during each call, such as translation and route determination. The complex operations are clearly proper to the central processor, but the simpler operations are conveniently performed by functional units connected to the

periphery of the switching network. Using peripheral mini-processors gives advantages in both hardware and software since the saving in the central processor outweighs the cost of providing the less powerful mini-processors. A simpler or slower central processor may suffice, or alternatively, a given processor may be used to serve a greater number of lines. The line sampling is performed by mini-processors, and messages are sent to the central processor only when a more complex operation is required. The operation of the central processor is thus simplified as fewer program interruptions are generated.

## CONCLUSIONS

The numerous benefits of standardization can be readily achieved at component level in conventional equipment, but as complexity increases through sub-assembly to complete functional unit, the extent of standardization decreases for economic reasons. With the improvements in technology

leading to more complex integrated circuits, it is becoming essential to standardize circuits so that the high development costs can be spread over long production runs. Programmable logic in the form of a very simple digital processor offers a solution by permitting standardization over a range of functions, and not just for a single function. This approach will facilitate the economic introduction of m.o.s.—l.s.i. technology, and give particular advantages in processor-controlled switching systems.

## References

- <sup>1</sup> REYNOLDS, F. H., and MORTON, W. D. Metal-Oxide Semiconductor (MOS) Integrated Circuits—Part 1—The MOS Transistor. *P.O.E.E.J.* Vol. 62, p. 168, Oct. 1969.
- <sup>2</sup> REED, E. D. Integrated Electronics. *Bell Laboratories Record*, Vol. 47, No. 8, p. 258, Sept. 1969.
- <sup>3</sup> KERSKOWITZ, G. J. Computer-Aided Integrated-Circuit Design. (McGraw-Hill, 1968), pp. 398–9.

---

# A new 20-Line Key-and-Lamp Desk Unit

J. L. A. LAWRENCE, C.ENG., M.I.E.R.E.†

U.D.C. 621.395.721.1:621.395.331.3

*A new 20-line key-and-lamp unit has been introduced for use in situations where the present 10-line unit is insufficient to provide the facilities required by the customer. The new unit is a logical development of the older one and uses the same circuitry and components.*

## INTRODUCTION

Key-and-lamp units have been used by the Post Office for many years, the two main applications being to provide customers with either order-table<sup>1</sup> or speech-broadcast facilities. They also provide an attractive and convenient switching unit for numerous non-standard requirements. Hitherto, the standard 10-line unit (Key and Lamp Unit No. 2A)<sup>1</sup> has been used in all modern installations and has given satisfactory service even though it is necessary to couple together two or more units when facilities are required for terminating more than 10 lines at a single operating position. Where a large number of lines is to be terminated at each operating position, a customer often prefers the key-and-lamp units to be integrated with his own furniture. In such a situation, the key-panels, together with the associated wiring and tag-strips of Key and Lamp Units No. 2A, may be mounted directly in a console provided by the customer. Fig. 1 shows part of an 80-line suite constructed in this manner.

The new 20-line desk unit (Key and Lamp Unit No. 10A), has been designed to satisfy the growing demand for neater installations which would otherwise need two 10-line units and for which the customer does not wish to provide special furniture. Fig. 2 shows part of a 30-line suite, using the new 20-line unit to the left of the telephone and a 10-line unit to the right.



FIG. 1—Ten-line key-and-lamp units installed in a console

## DESCRIPTION OF THE NEW DESK UNIT

In appearance, the new desk unit, illustrated by Figs. 3 and 4, closely resembles the P.M.B.X. No. 2/2A.<sup>2</sup> It uses the same

† Telecommunications Development Department, Telecommunications Headquarters.



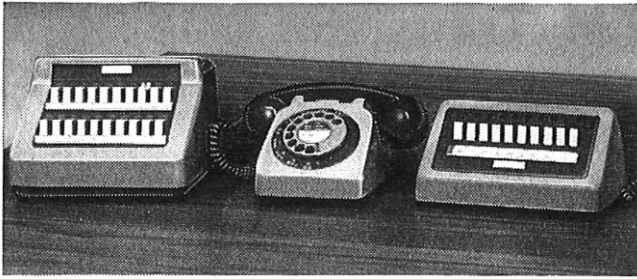

FIG. 2—Installation using one 10-line and one 20-line unit

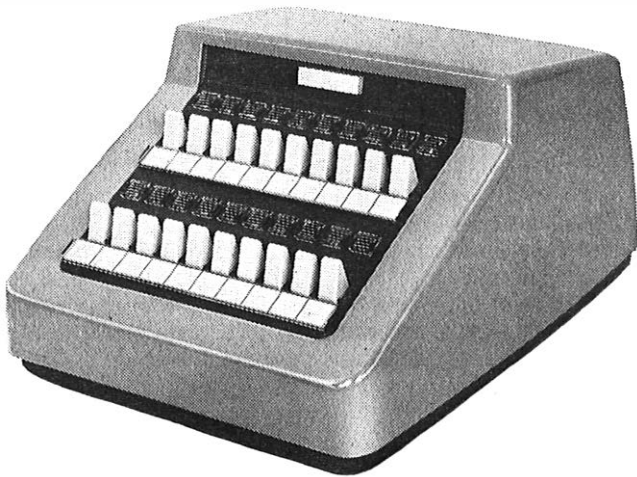

FIG. 3—Key-and-Lamp Unit No. 10A

moulded case in A.B.S.,\* the base-plate and mounting bracket are similar, and the key-panel has the same elephant-grey stoved textured-vinyl finish. The key-panel carries two sets each of ten lamps and ten 1,000-type keys,<sup>3</sup> and a single key-bar operating a micro-switch. Each 1,000-type key has the basic wiring for one line circuit but the last keys of the two rows have additional wiring to allow them to be readily used for other purposes, should this be necessary.

The wiring is identical to the 10-line unit, there being the equivalent of two separate 10-line units contained within the single case; each set of 10 lamps and 10 keys is wired independently to separate tag strips. The key panel is hinged so that it may be swung forwards to allow easy access to the

\* A.B.S.—Acrylonitrile-butadiene-styrene.

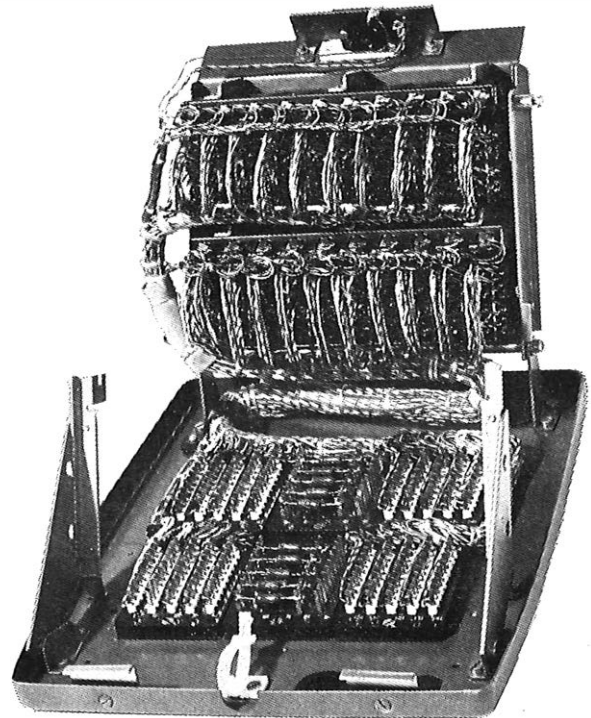

FIG. 4—Interior of Key-and-Lamp Unit No. 10A

tag-strips when the distribution cable is to be connected. The cable clamp can be turned through a right angle so that the distribution cable may be firmly gripped whether it enters the unit from the rear or, if the customer prefers concealed cabling, through the base. The new 20-line unit is stocked as a complete item and works in association with the same type of auxiliary relay-units for order-table and speech-broadcast systems as the 10-line unit.

#### References

- <sup>1</sup> DAVEY, L. R. New Key-and-Lamp Desk Unit. *P.O.E.E.J.*, Vol. 56, p. 156, Oct. 1963.
- <sup>2</sup> HALLIDAY, C. M., and LIDBITTER, E. J. A New Cordless P.M.B.X. Switchboard. *P.O.E.E.J.*, Vol. 54, p. 22, Apr. 1961.
- <sup>3</sup> CLARKSTONE, K. H. A Miniature Lever Key of Improved Design. *P.O.E.E.J.*, Vol. 55, p. 29, Apr. 1962.

# Recent Development in F.D.M. Transistor Line Systems

J. R. MILLER, C.ENG., M.I.E.R.E., and J. A. L. GIPP†

U.D.C. 621.395.457: 621.315.212.4

*Following a short history of transistorized coaxial-line systems this article describes how the requirements of a modern 12 MHz line system have been met by the Post Office Coaxial Line Equipment C.E.L. 4000. The C.E.L. 4000 has been specified as a standard line system in an attempt to reduce the maintenance costs and equipment spares which have to be held. The principal elements are described with some explanation of their operation.*

## INTRODUCTION

There are two types of coaxial cable in common use in the United Kingdom. One has an inner diameter of the outer tube measuring 0.174 in and is known as 174-type<sup>1</sup> or *small bore*. The other has an inner diameter of the outer tube of 0.375 in and is known as 375-type.

One of the first transistor coaxial line systems used by the British Post Office, C.E.L. 1000, provided 300 telephony channels over a maximum of 60 miles of 174-type coaxial cable. This system was very successful and still gives service. Confidence with the transistor equipment was established and the now well-known advantages of transistor systems over valve systems were quickly confirmed. In view of this, early attention was given to designing a wider-bandwidth system. The choice of top frequency for the system to supersede the C.E.L. 1000 was limited by the then available transistors. The bandwidth selected was 4 MHz (60 Hz to 4,092 kHz) to provide compatibility with existing equipment. This system, C.E.L. 1006,<sup>2</sup> used substantially the same mechanical and electrical features as those of the C.E.L. 1000. It was designed to operate on 174-type cable or 375-type cable, to satisfy the performance recommendations of the C.C.I.T.T.,\* and to operate within the current and voltage limits considered safe by the Post Office. Soon after the 4 MHz systems came into production the transistors available improved and consideration was given to even greater bandwidth systems. The next development was a 12 MHz system, C.E.L. 1007, designed to

work with 375-type cable and to have broadly the same parameters as existing valve 12 MHz systems. The spacing of the dependent repeaters for this transistor system has been made one half of that used for the 4 MHz system, to facilitate later upgrading of 4 MHz routes to 12 MHz. The normal spacing of dependent-repeater and power-feeding stations for various systems is shown in Table 1.

## THE DESIRE FOR STANDARDIZATION

The coaxial systems mentioned so far were specified by the Post Office in terms of overall system performance in a manner suitable for purchase by competitive tender, leaving freedom for manufacturers to offer their own individual design meeting the required overall performance.

As a consequence, the Post Office was faced with the operation and maintenance of a number of different systems with the same circuit capacity, the holding of a large stock of maintenance spares, and the training of staff for each type of equipment. Although the first transistor 12 MHz system was extremely successful, it was realized that there would be advantages in having a 12 MHz system that could operate with either 174-type or 375-type cables. The greater loss of 174-type cable, compared to 375-type cable, and the consequently larger number of repeaters required, made it necessary to design dependent repeaters having a lower noise production if the overall performance objective was to be achieved. As a further aid to flexibility and economy the Post Office decided that for the new system, all functional units, e.g. line repeaters, would be sufficiently closely defined to enable units from different manufacturers to be interchangeable.

TABLE 1

Comparison of Transistor Coaxial Line Systems

System	Traffic Band kHz	Circuit Capacity	Nominal Repeater Spacing		Maximum Power Feeding Distance	
			174-Type km	375-Type km	174-Type km	375-Type km
C.E.L. 1000 .. .. .	60- 1,300	300	5.7	—	96	—
C.E.L. 1006 .. .. .	60- 4,028	960	4	9.3	65	144
C.E.L. 1007 .. .. .	312-12,388	2,700	Not suitable	4.5	—	76
C.E.L. 4000 .. .. .	312-12,388	2,700	2	4.5	30	65

† Telecommunications Development Department, Telecommunications Headquarters.

\* C.C.I.T.T.—International Telegraph and Telephone Consultative Committee.

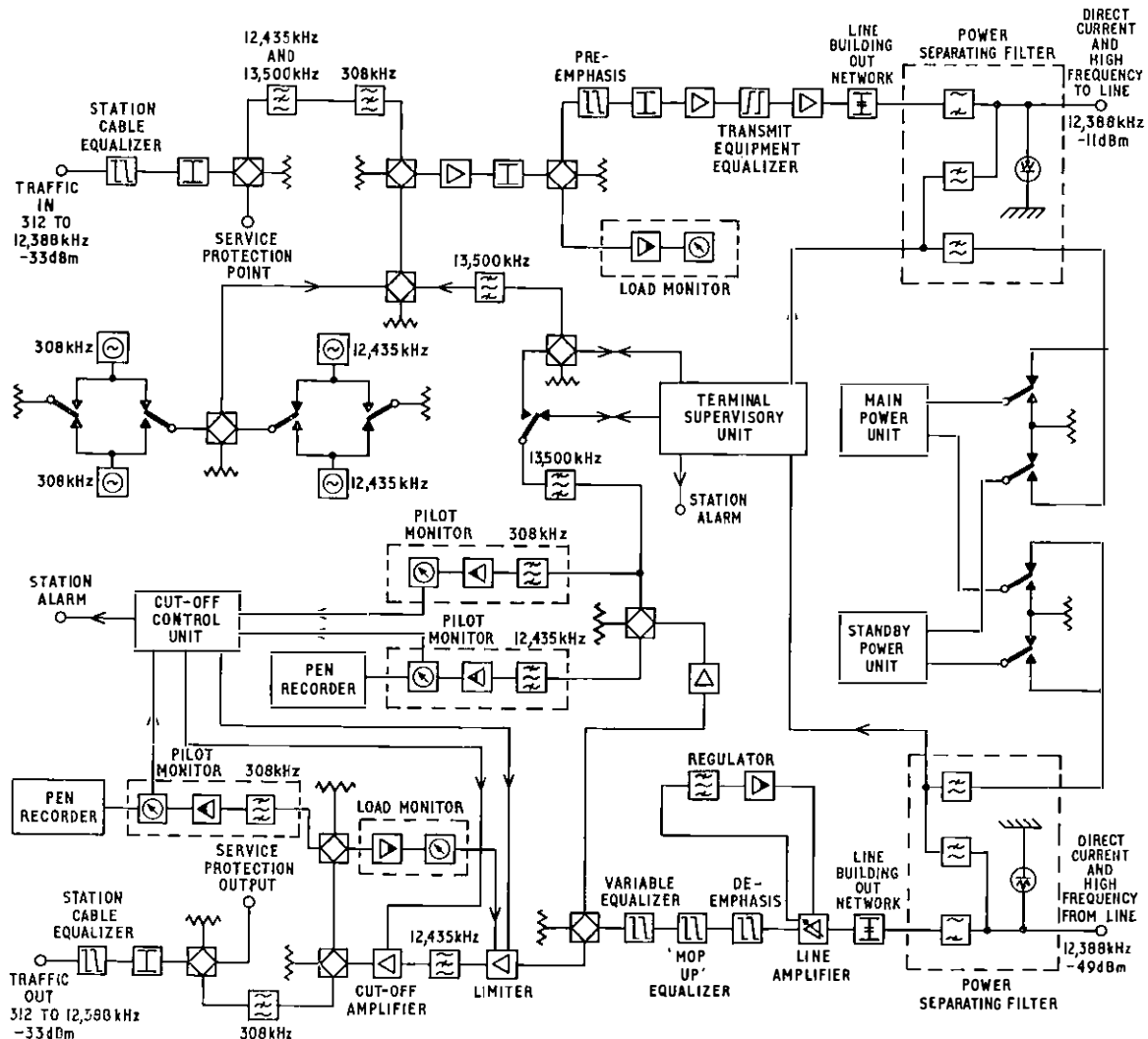

FIG. 1—Block diagram of the terminal equipment

## THE STANDARD 12 MHz LINE SYSTEM C.E.L. 4000

### Overall System Requirements

In order to define a standard system, a series of specifications was built up. This consists of a master specification, which lays down the overall make-up and system performance parameters, together with ancillary specifications, each of which details a single unit having defined mechanical and electrical interfaces. Each unit can be removed from the system and a replacement, manufactured by any manufacturer, substituted. The objective was to enable substitution to be made whilst maintaining the overall system performance.

### Coaxial-Line-System Requirements

The line system needs to have a working life of at least 20 years. Towards the end of such a period, the maintenance effort relative to quantity of equipment may be much lower than it is today. For this reason, the system should operate with very little attention and failures should be easily located.

There are four main engineering aspects of a line system which have to be considered and the parameters detailed.

#### Transmission Path

The traffic path needs to provide 2,700 telephony circuits. System pilots need to be provided, monitored and confined within the system boundaries. Also, the equipment must operate from the standard 24-volt repeater-station supply and

circuit performance be maintained over the expected ambient temperature range.

Induced voltages resulting from lightning discharges or electricity-power-line failures must not permanently affect the transmission paths. Also, the wideband output level from the system must be limited to prevent this overloading any system connected to it.

The repeater spacings must be such that existing routes equipped with 4 MHz systems may be re-equipped with the new system without the necessity of resiting the existing repeater points.

#### Power Path

The power path feeding the dependent repeaters must be intrinsically safe. Power is normally fed via the inner conductors of the two coaxial tubes of the system but has to be maintained on one coaxial tube when the other fails. The power-feeding units have to be duplicated so that failure of one power unit does not result in failure of the traffic path.

#### Supervisory System and Speaker

The supervisory system must provide facilities to enable location of a transmission-equipment failure to be made unambiguously, to locate the faulty power-feeding section in the event of a power-failure fault and to be self monitoring. The system must operate via the coaxial tubes only, be simple to operate and be able to provide supervisory signals in a form suitable for relaying to a distant network co-ordination centre.

The speaker system must permit selection and calling of

any desired power-feeding station from any dependent or terminal station and permit calling of all dependent stations at which a portable speaker-box is connected. The speaker system must also provide a usable speech circuit.

#### *Mechanical Arrangements*

The dependent repeater (two transmission paths) is required to fit into one half of the Post Office standard repeater case C.R.E. No. 1.<sup>3</sup> To repair a defective transmission path due to a faulty unit in a repeater, it is necessary to be able to change the faulty unit without affecting the working transmission path. The equipment provided for lightning protection has to be removable and replaceable without causing disturbance to the transmission path.

The terminal and power-feeding stations were required to be constructed in 62-type equipment practice.

### **TRANSMISSION SYSTEM OF THE C.E.L. 4000**

The C.E.L. 4000 system was designed to provide a zero-gain low amplitude/frequency distortion circuit over a distance of about 300 km of 375-type or 174-type coaxial cable. A block diagram of the terminal equipment is shown in Fig. 1.

#### **Terminal-Station Transmit Equipment**

The traffic input is made via a hybrid, the spare output of which is normally closed in 75 ohms. This is used to facilitate diversion of traffic from the line system to another without loss of service. The pilot-stop filters prevent both the pilot energy being fed back into the translating equipment and noise from the translating equipment at the pilot frequencies affecting the system. The system pilots are injected before the first active elements. After the pilot-injection hybrid, the traffic signal is amplified by a 20 dB flat-amplifier. In the transmission path, pre-emphasis giving 10 dB of slope is provided. (Pre-emphasis and de-emphasis is applied to a line system to achieve a more uniform signal/noise ratio over the traffic band.) After a further 20 dB flat-amplifier an equalizer is provided to compensate for the unwanted gain/frequency distortion so far introduced. The signal is then transmitted to line via a flat amplifier and power-separating filter (p.s.f.). The p.s.f. is the point at which the high-frequency traffic and d.c. power, to energize dependent repeaters, are combined.

The p.s.f. is connected directly to the coaxial cable and is the first piece of equipment where protection against high induced voltages from line can be provided. This is done by fitting gas discharge tubes between the centre conductor of the coaxial tube and earth.

The discharge tube is rated at a voltage above the maximum voltage that the line power equipment will provide. Any higher voltage present on the line, of either polarity, will be limited to the burning value of the gas discharge tube which will thus protect the transmission equipment.

The length of cable which can be interposed between the amplifier stations is determined by the loss of the cable and the permissible noise that each section length can be allowed to contribute to the total. Nominal figures of 4.5 km for 375-type cable and 2 km for 174-type cable were chosen to give an acceptable system noise performance.

#### **Dependent-Repeater Equipment**

Dependent repeaters are the most frequently recurring items of apparatus on most routes; their performance has a dominant effect on the overall performance. The dependent repeater has been designed to provide the following main electrical features:

- (a) amplification to compensate for the cable losses,
- (b) building-out networks for short-section lengths,
- (c) change of gain to match cable loss changes with temperature (regulation),

- (d) separation of power and traffic,
- (e) supervisory facilities,
- (f) induced voltage protection, and
- (g) high crosstalk margin.

Dependent-repeater amplification is provided by means of a transistor amplifier with a maximum gain of about 38 dB at 12 MHz and is manually adjustable in non-regulated repeaters and automatically adjusted under the control of a pilot in regulated repeaters. The adjustment is used for temperature regulation in a regulated repeater ( $\pm 4$  dB) and to cover siting tolerances in a non-regulated repeater ( $\pm 6$  dB). For short cable sections, line building-out (l.b.o.) networks are provided to suit the particular cable section length. They remain *in situ* when the interchangeable units are removed or replaced.

As the power available for the amplifier is small (and most of this is used in the output stage) the maximum output level obtainable is very limited. As a principle, the output level at any dependent repeater is set to this maximum value. Any gain variations which have to be made, are done maintaining the fixed output level.

To offset the changing loss of the line with variation of temperature, a regulations system is used which measures the level of a pilot and adjusts the amplifier to maintain a pre-determined level at the amplifier output. In common with earlier transistor line systems, a single pilot just above the traffic band is used; the regulating-pilot frequency is 12,435 kHz. In each regulating repeater, the pilot is filtered, rectified, and compared with a standard; the difference signal produced is used to vary the amplifier gain to compensate. The range of regulation available is sufficient to deal with the attenuation variations of two repeater sections. The regulated amplifiers are normally sited alternately with non-regulating amplifiers.

In the event of regulating-pilot failure, the regulator drives the amplifier gain to its nominal value; this helps to maintain the traffic path and permits the supervisory system to continue in operation.

The power to operate the dependent repeater is extracted from the inner conductors of the coaxial cable by means of p.s.f.s at the input and output of the dependent amplifiers. The power feed is a constant current of 50 mA, which develops 25 volts across the amplifier. A zener diode is connected across the load to protect the elements in the repeater against excess current due to extraneous effects such as lightning (Fig. 2). This diode, together with gas-discharge tubes, provides the primary protection against surge voltages. Transistors and other sensitive elements are given secondary protection by means of diodes, normally non-conducting, but which conduct when excessive, or reverse-polarity voltages are present.

A major problem in the dependent-repeater design is obtaining an adequate near-end crosstalk margin. The extreme signal-level differences within the repeater can exceed 38 dB, and to obtain the very high values of crosstalk attenuation required, the structure is kept coaxial as far as possible and double screening is used. For far-end crosstalk, no level differences are involved and the problem is less severe.

#### **Terminal Station Receive Equipment**

At the receive terminal, Fig. 1, the signal is first treated in the same manner as at a regulated dependent repeater. The only differences are that the line amplifier is energized from a local source and that the regulator control-ratio is increased to assist in reducing regulator hunting to a tolerable value. The signal is then passed through a de-emphasis network to return the traffic band to a nominally-flat characteristic. A residual equalizer is provided to optimize the gain/frequency response for the particular route. A high degree of gain/frequency linearity is required so that the system can operate as part of a low-distortion multi-link connexion. A manually-

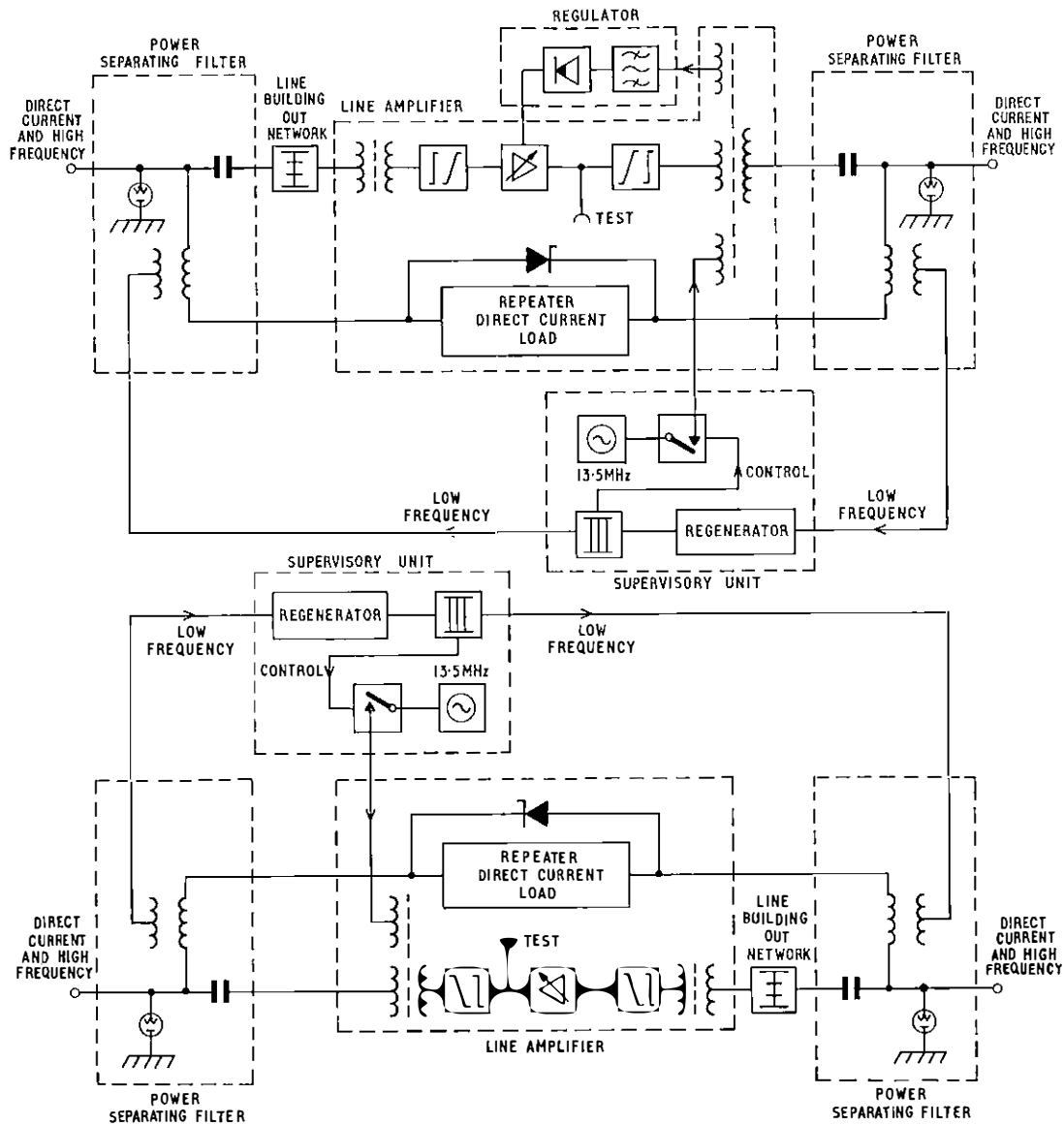

FIG. 2—Simplified block-diagram of the dependent repeater equipment. (The regulator unit is fitted at alternate repeaters in each direction of transmission)

adjustable variable equalizer is provided to equalize small gain/frequency changes which result from seasonal temperature changes of the cable. This equalizer comprises a number of resonant circuits which can be arranged to provide a gain or loss of 4 dB at discrete frequencies. These frequencies are arranged to occur at the points where they will be of greatest benefit. A limiting unit, normally having zero gain and under the control of a load monitor, is provided. Under conditions of excess loading, attenuation is introduced by this unit to ensure that the wideband output from the system does not exceed the nominal maximum loading by more than 1 dB. Both system pilots are then suppressed with filters. The final amplifier incorporates a facility to disconnect (cut off) the system when fault conditions are present.

All active elements, from transmit input to receive output, are traversed by a 308 kHz pilot which is extracted after the final receive amplifier. The 308 kHz pilot in the traffic path, together with the 12,435 kHz and supervisory signals, are also extracted at a point after the variable equalizer. From this point both pilots are monitored, the output from the 12,435 kHz monitor being connected to a pen recorder. The 12,435 kHz pilot is monitored once and the 308 kHz pilot is monitored twice to reduce the possibility of misoperation of the cut-off amplifier. Each monitor is connected to the cut-off

control unit which transmits alarms and control conditions. If the transmission path fails, the loss of both pilots is detected and a condition sent from all three monitors to the control unit. The reception of the pilot-fail signal from all three monitors is the only condition which will cause the control unit to send the cut-off condition to the final amplifier. On receipt of the cut-off signal, attenuation of at least 25 dB is introduced into the traffic path. An additional condition is also sent to the limiting unit which produces the maximum loss from the level limiter (approximately 10 dB). When the traffic path is restored, it may possibly have excess system gain due to the dependent repeaters being at nominal gain during the period that the regulating pilot was absent when a lower gain was required. Recovery, however, takes only a few seconds and during this period the limiter and cut-off facility prevent high levels being presented at the traffic-out terminals. In this way the system is prevented from overloading subsequent systems. The rate of return of system gain is governed by the limiter so that any group automatic-gain-control equipments having maximum gain as a result of the transmission break, will not cause the overall group circuit to have excess gain.

Pilot alarms are provided independently of the supervisory system and thus the condition of the system is both monitored

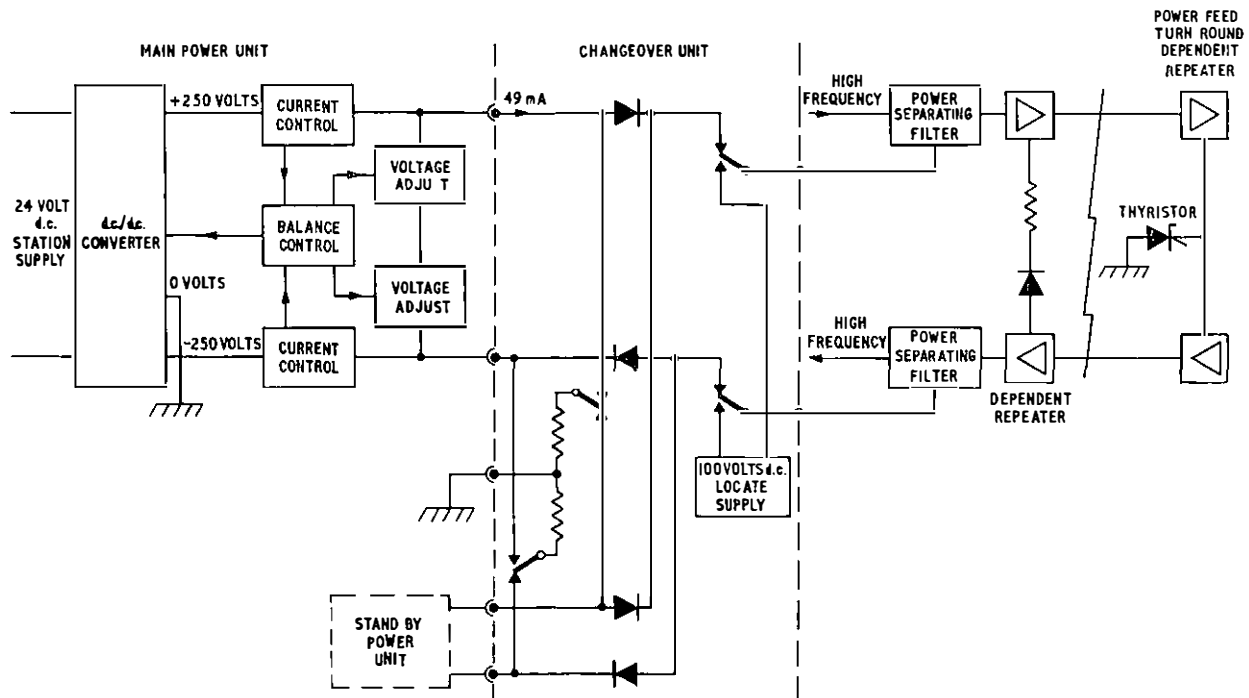

FIG. 3—Simplified diagram of the power-feeding arrangements

and an alarm given for major failures independently of the supervisory system.

A load-monitor is fitted to monitor the level of traffic at the receive terminal. This monitor has a control output which is connected to the level limiter. Should the nominal traffic-load be exceeded, the load-monitor causes the level limiter to introduce sufficient loss to restore the traffic-out level close to nominal. This prevents any overload conditions being passed on to subsequent equipment. The level limiter only introduces sufficient loss to return the output to nominal.

### POWER SYSTEM OF THE C.E.L. 4000

The power equipment for the C.E.L. 4000 system incorporates the facility of maintaining one direction of transmission when the other has suffered a power fault. A block diagram of the power system is shown in Fig. 3. At the terminal station two power units are provided and connected via a changeover unit to line. Each power unit is capable of providing a safe constant current of 50 mA at a maximum voltage of 250 volts derived from the 24-volt station supply. Such a power system is non-lethal and personnel may work on the system with the power connected. Two current-control units feed a balance control, which ensures that each unit provides half the power. Should one of the coaxial tubes become disconnected, the remaining good tube is automatically energized via an earth-return path. Additionally, voltage-maximum clamp adjustment is also provided such that the power-unit output voltage will not rise above a value appropriate to the number of repeaters to be energized.

Two power units are connected to a single changeover unit. This changeover unit has, inbuilt, all the voltage and current measurement devices together with the alarms for both power units. The current from the stand-by unit is fed into a low-resistance dummy load situated in the changeover unit and thus can be monitored. The main power unit passes power to line via diodes; in this condition the path to line for the stand-by unit is via reverse-biased diodes and thus no current passes; failure of the main power unit causes the reverse bias to be removed.

Should a line fault occur such that the supervisory is inoperative, e.g. as a result of the loss of power-feeding loop, an arrangement for locating such a fault is provided by means of a 100-volt supply which may be connected to the line in

reverse polarity after the power-feeding current has been removed. The reversed voltage causes diodes, normally non-conducting, which are placed across the line at the dependent repeaters, to conduct. The magnitude of the current enables the position of the fault to be determined.

The arrangements in the dependent repeater for deriving power are shown in Fig. 2. All the repeaters are connected in series. At the end of a power feeding loop a power-feed turn-round (p.f.t.r.) repeater is fitted. This repeater has to provide a d.c. path between the two transmission paths and when one of the coaxial tubes fails, applies automatically, a d.c. earth connexion to the coaxial inners forming the power-feed loop circuit.

The number of repeaters that can be power fed in one loop is restricted by the maximum voltage permissible (250 volts). Seven dependent repeaters may be connected in one power-feeding loop. Most routes comprise many dependent repeaters and additional power-feeding stations are required at intervals along the route.

### Power-Feed Stations

The power-feeding stations require a source of power and thus must be installed in a surface building. At such a station the opportunity is taken to give some facilities over and above those of dependent repeater stations. A block diagram of the power-feed station is shown in Fig. 4. The traffic passes through a p.s.f., line amplifier, regulator and de-emphasis network as at a terminal station. Two hybrid transformers are then fitted; these are used to enable the variable equalizer to be taken in or out of service without interruption to traffic. Following the second hybrid, an amplifier makes up the losses. A further injection point precedes the pre-emphasis network after which a flat amplifier and a p.s.f. are provided.

The power-feed station is fitted with an auxiliary pilot oscillator for the following reason. In order to preserve the traffic path when the regulating pilot fails, the dependent repeater regulator returns the repeater to nominal gain. At worst, this gain may be 0.8 dB greater than that required at every regulated dependent repeater. Over an average length route, this extra gain would create an overload problem and would destroy the supervisory information and make the fault location impossible. To prevent this, a control lead from

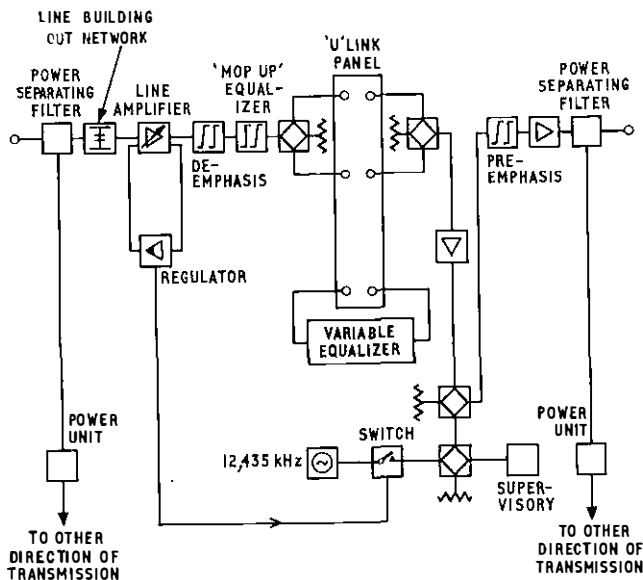

FIG. 4—Block diagram of the power-feeding station (one direction of transmission only)

the power-feed-station regulator switches the oscillator to line when loss of the normal pilot is detected and so controls the gain for the remainder of the route. The variable equalizer is provided in order to equalize the line for small residual errors.

### THE SUPERVISORY SYSTEM FOR THE C.E.L. 4000

Supervision is carried out over the coaxial pairs. The supervision of each direction of h.f. transmission is normally carried out on a unidirectional basis, each terminal station supervising the incoming direction. Facilities have been provided to enable either terminal to extend the supervision so that both directions can be supervised from one terminal (supervisory extension).

Supervisory units are located at all dependent repeaters and other points such as power-feeding (p.f.) stations and distant terminal stations. The supervisory system operates by interrogating units to be supervised sequentially on a continuously repeating cycle and indicates immediately any faults occurring.

The system has been designed so that the removal or failure of any unit of the supervisory apparatus causes an alarm. This facility is desirable as the reliability obtained with present-day transistorized coaxial systems is such that supervisory equipment will be required only infrequently.

The design of the system is such that with further development it may be possible to arrange the supervision of a number of systems from a central control point (network co-ordination centre).

### Principles of Operation

At each receiving end of the line system, a triggering pulse is injected into the line via the power-feeding circuit. This pulse has a repetition rate of six per second and is of  $100 \mu\text{s}$  duration. A low-pass filter prevents any energy being injected into the traffic band. The pulse is transmitted between the centre and outer conductor of the receive-direction coaxial tube and travels in the opposite direction to that of the h.f. transmission signals.

At the dependent repeater, the triggering pulse is extracted at a point in the p.s.f. situated at the output of the repeater and fed to the repeater supervisory unit (Fig. 2). The incoming pulse is arranged to operate a regenerating circuit which provides a regenerated triggering pulse for injection, via the p.s.f. situated at the input to the repeater, for transmission to, and triggering of, the next repeater or next point on the system. The regenerated triggering pulse also allows a train of locally-generated  $13.5 \text{ MHz}$  signal, whose envelope is in the form of a pulse of  $100 \mu\text{s}$  duration, to be injected into the h.f. path at the output of the repeater for transmission to the interrogating terminal station. The injection of both the regenerated triggering pulse and the  $13.5 \text{ MHz}$  r.f. pulse commences  $240 \mu\text{s}$  after the receipt of the received triggering-pulse. This sequence of events is repeated at each intermediate point until the final supervisory unit is triggered.

At the interrogating terminal-station the supervisory receiver monitors the reception of successive  $13.5 \text{ MHz}$  r.f. pulses (Fig. 5). On receipt, the r.f. pulses are applied to a detector circuit which accepts those falling within a predetermined range of amplitudes; pulses which deviate beyond the predetermined levels are rejected and cause an alarm to be given. Those falling within the prescribed limits are applied to an input-gate which allows each to pass through to be counted. Each pulse causes the gate to open for the next pulse at or about the time it is due to arrive. The input-gate remains open just long enough to allow each pulse through. This sequence continues, each r.f. pulse being counted; finally at the end of the count the total is compared with a number registered in a store as being appropriate to the system. If the figures do not agree, an alarm is given.

Provision is made in the receiver for a display to show the number of correct pulses counted. A further facility is provided on the receiver such that when a r.f. pulse falls outside the prescribed limits, a locally-generated pulse can be manually

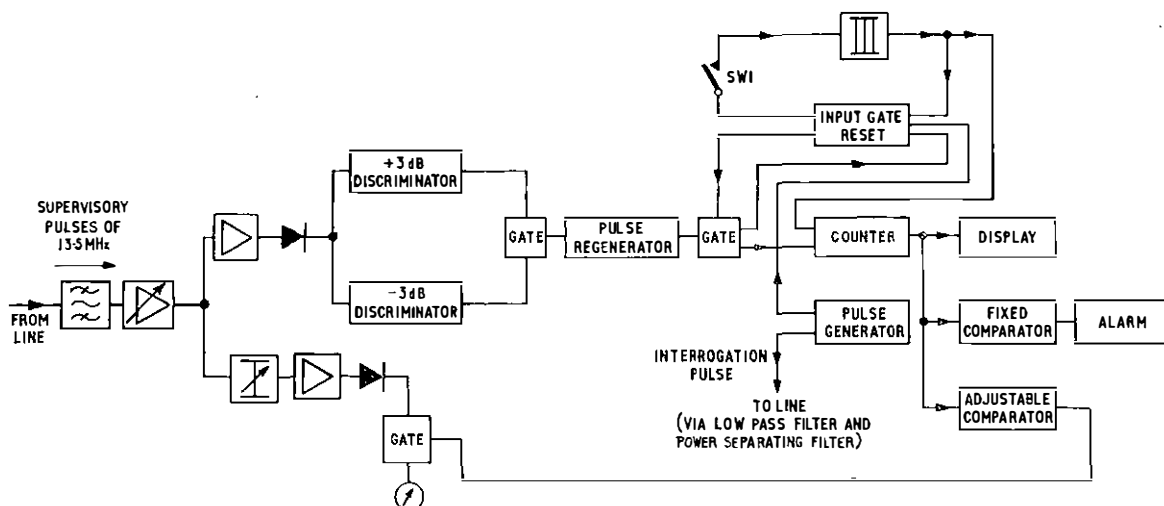

FIG. 5—Terminal-station supervisory equipment

switched to substitute for the failed pulse and so allow the supervisory system to check the remaining pulses, and continue supervising the route until the fault is cleared. Provision is also made in the receiver for pulses originating from successive interrogations from any selected point to have their mean level displayed on a decibelmeter. This output can also be applied to a pen-recording decibelmeter where it is possible to detect small changes in the mean level of the pulses originating from the selected point of the order of 0.1 dB and breaks in transmission of 300 ms and longer.

### Other Use of Supervisory Units

The use of supervisory units is not limited to monitoring dependent-repeater sections. Alarm transmission units, having facilities for returning up to 16 separate r.f. pulses, are fitted at terminal and power-feeding stations for supervising power-feeding and oscillator changeover apparatus, pilot monitors, etc. It is noteworthy that the supervision of features not necessarily part of the coaxial system can be integrated into the supervisory system. For example, the level of oil in fuel tanks could be monitored.

Two supervisory units are fitted at each dependent repeater, one for each transmission path; the power supply for these units is obtained from the line power-feed supply feeding the repeaters. At p.f.t.r. dependents, four supervisory units are fitted. These are arranged so that the failure of any power-feed loop in the system can be identified.

When any fault occurs, its location can be determined by observing the number of correctly-received pulses displayed on the counter of the receiving terminal.

Extension of the supervisory system to give complete supervision from one terminal is achieved by the transmission of a code to the distant terminal from the terminal requiring to carry out the supervision. This code, when received at the distant terminal station, causes a supervisory looping path to be connected allowing both tubes to be supervised. The supervisory system is restored to normal unidirectional supervision by transmitting another code.

### THE SPEAKER CIRCUIT

An engineering speaker circuit is provided on the interstice pairs and designed to work 4-wire duplex. The pairs are loaded with 88 mH coils at 2 km spacing when used on 174-type coaxial cable and 44 mH coils at 4.5 km spacing on 375-type coaxial cable. Standard Post Office audio repeaters are fitted at all terminal and power feeding stations.

Speaker shelves are provided at terminal stations and power-feeding stations and a selective-calling system using an interrupted single audio frequency (Fig. 6) enables up to 27 stations to be called selectively. Additional logic can be fitted to extend this number. The speaker equipment occupies a complete shelf, including a housing for the handset.

A portable speaker box is provided for use at dependent intermediate stations with the same calling facilities available as at the terminals and power-feeding stations. When the box is connected in circuit at a dependent repeater, that repeater can be called non-selectively from any terminal, power-feeding station or other speaker box, by the transmission of a continuous 800 Hz signal. This calling signal actuates a small loudspeaker mounted in the portable speaker.

### Operation of the Calling System

The number to be called is set on the selector switch (Fig. 7). When the call key is operated, the 800 Hz oscillator is switched on and a start signal of 800 Hz is transmitted, followed by a train of pulses of 800 Hz at 10 pulses per second corresponding to the number set on the selector switch. The start signal is intended to prime the receiver and to minimize the possibility of false operation due to noise bursts.

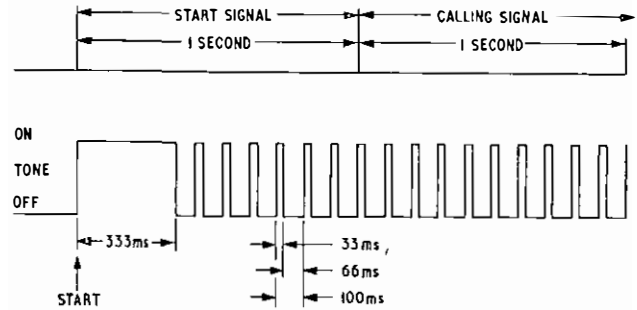

FIG. 6—Speaker calling signal

The signal received from the calling station passes through an 800 Hz detector and provides an input to a d.c. amplifier having two outputs. One output goes to a binary counter and the second output to a pulse-train-complete circuit. All the stations receive the train of pulses and when the code accords with that prescribed for the particular receiving station, signals are transmitted to the alarm input gate. Only the appropriate station will be programmed to accept the particular signals required to prime the alarm gate for operation.

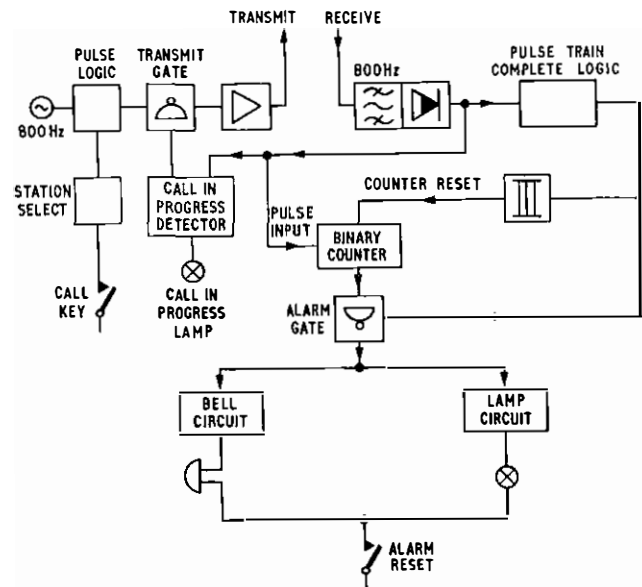

FIG. 7—Block diagram of speaker selective-calling system

The gate cannot open to give an output until a further signal arrives indicating that the pulse train has been completed. On arrival of this signal the alarm gate operates, providing two outputs. The first output operates a locking circuit for the call lamp, the second output switches a non-locking audible alarm. This alarm can be set up to give an alarm for a five-second or ten-second period.

The called circuitry reset is automatically applied after a suitable time has elapsed, thus resetting the alarm input gate to normal. The time must be long enough to ensure that the alarm input gate has fully completed its function.

### Use of the Speaker System

In addition to the normal use for calling and speech, the calling circuit may also be used for switching the supervisory extension, a code being allocated for this operation. Further extension of this remote switching facility can be made if required.

A 1,140 Hz pilot is transmitted continuously over the speaker circuit for monitoring and suitable stop-filters are provided to prevent interference. A failure of this monitoring pilot gives alarms to both terminals.



## MECHANICAL ARRANGEMENTS

The C.E.L. 4000 terminal and power-feeding station equipment is of 62-type construction, and each occupies 11 shelves. The p.s.f.s and power changeover unit are made captive cards in order to avoid the accidental removal of power from the system. These cards can only be withdrawn a few centimetres; this allows access to the lightning protectors and some controls on the changeover unit. The dependent repeater fits into the Post Office standard repeater case C.R.E. No. 1.

In Fig. 8(a) it can be seen that the complete repeater occupies half the volume available for equipment in the C.R.E. No. 1. The two main portions of the repeater can be seen each with its test point and information card. In this design, the internal elements are exposed by removing the side panel of each portion of the repeater. The centre section houses the building-out networks and is fitted with a carrying

any earlier systems. Also, many features have been provided to facilitate maintenance. Examples of this are providing the minimum number of changeover points, protecting all test points and single-tube working under fault conditions. The supervisory system will provide a rapid and accurate location of faults, and may eventually be connected to a central control point, e.g. a network co-ordination centre.

Only practical experience of the equipment in the field will show if the objectives of the C.E.L. 4000 have been satisfactorily met. A field trial has been in successful operation for at least 12 months and there is every reason to believe that the production equipment, which is due to be in service by 1971, will meet with the same degree of success.

Transistorized coaxial line systems have proved their value in the existing network and will continue to be used for a good many years to come.



(a) Dependent repeater in the C.R.E. No. 1

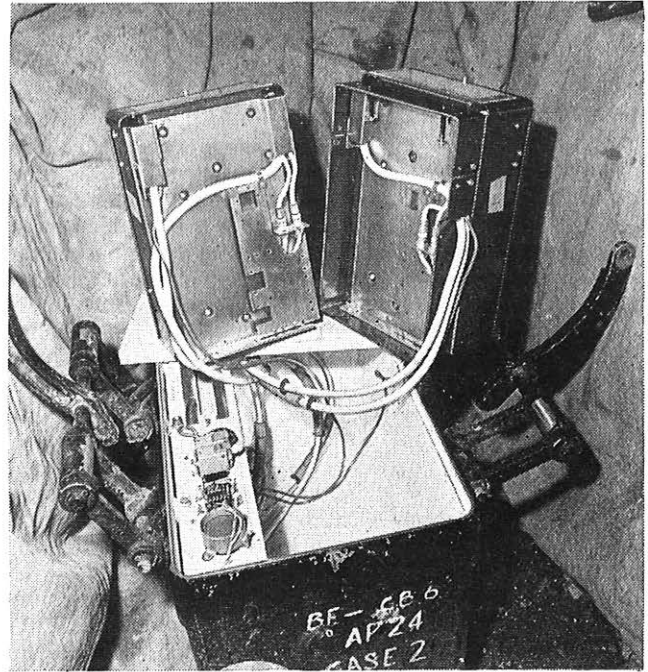

(b) Dependent repeater lifted clear of the C.R.E. No. 1

FIG. 8—Dependent repeater for two transmission paths mounted in a C.R.E. No. 1

handle; it also secures the two main repeater sections. Connection to the external cable is made via flexible coaxial leads and connectors; these coaxial leads together with an earth lead are the only connexions required. Fig. 8(b) shows the two portions of the dependent repeater lifted clear of the C.R.E. No. 1 and separated.

## CONCLUSION

In developing the C.E.L. 4000 coaxial line system, an attempt has been made to achieve a system having uniform facilities, controls and maintenance procedures, together with a transmission performance superior to that obtained with

## ACKNOWLEDGEMENT

The equipment shown in Fig. 8 was provided by Standard Telephones and Cables Limited. The equipment for the field trial route was jointly provided by Standard Telephones and Cables Limited and G.E.C.-A.E.I. Telecommunications Limited.

## References

- <sup>1</sup> ALLAN, A. F. G. Small-Diameter Coaxial Cable Developments. *P.O.E.E.J.*, Vol. 57, p. 1, Apr. 1964.
- <sup>2</sup> BARBER, D. R. A Transistorized 900/960 Channel Small-Core Coaxial Cable System. *I.E.E. Transmission Aspects of Communications Network*, Feb. 1964.
- <sup>3</sup> CLINCH, C. E. E. and STENSON, D. W. Housing of Repeater Equipment Underground. *P.O.E.E.J.*, Vol. 56, p. 158, Oct. 1963.

# Fast Signalling in the U.K. Telephone Network

B. R. HORSFIELD, C.ENG., F.I.E.E.†

U.D.C. 621.395.38: 621.395.74 (410)

*Developments in the U.K. telephone system have created a need for faster signalling between exchanges. The author compares the use of separate data channels for signalling (a technique which is more suitable for use at processor-controlled exchanges than other types of exchange) with conventional channel-associated methods. The problems of introducing such a system into the existing network could possibly be reduced by the use of an "overlay" approach, but the time needed to assess the economic implications and subsequently implement any decisions, may make parallel development of conventional signalling methods desirable.*

## INTRODUCTION

The very great extension of the dialling range available from subscribers' installations, which has resulted from the rapid growth of subscriber trunk dialling (s.t.d.) and international subscriber dialling (i.s.d.), coupled with the development of fast switching systems and the appearance of the pushbutton telephone (keyphone) have jointly resulted in a need for faster methods of signalling between telephone exchanges.

In the past, with dial-type telephones and predominantly nonregister step-by-step switching, the use of 10 pulses per second dial-type pulses (referred to in this article as Strowger pulsing) has been fully acceptable as a method of signalling numerical information between exchanges. However, as it becomes increasingly necessary to store digits within exchanges and to retransmit them after allowing time for certain switching functions to be completed, the use of Strowger pulsing on multilink connexions can result in undesirable postdialling delays before receipt of ring tone. The need to store and retransmit digits frequently arises when register control of switching is introduced. Registers may be required, as in the director system and the s.t.d. network, to allow flexibility of routing within a linked numbering scheme and they are required to permit the use within an exchange of new connecting devices such as reed relays or crossbar switches which cannot readily be directly controlled by dial pulses. Registers are always required to receive fast signals from keyphones, and, if step-by-step switching or Strowger pulsing is used, the postdialling delays on multilink calls from such instruments may become excessively long. Accordingly, if keyphones are made generally available, the pressure to provide fast signalling throughout a large part of the telephone system is likely to be greatly intensified.

The use of alternative methods of numerical signalling to Strowger pulsing opens up the possibility of greatly increasing the signalling capacity of the telephone system, thereby facilitating the relaying of services such as class-of-service information and calling-number identification between exchanges; it also makes possible the incorporation of error-detecting features leading to automatic repeat attempts on calls which are unsuccessful on the first attempt. It is unlikely that any fast-signalling system would be standardized for general use in the network unless it offered these additional advantages.

The need to minimize postdialling delays, to provide increased signalling capacity, and to incorporate automatic-repeat-attempt features was recognized at the outset during the planning of the new trunk network<sup>1</sup> where calls between

group switching centres (g.s.c.s) may be routed through as many as four and, exceptionally, five register-controlled transit switching centres (t.s.c.s), and fast-signalling capabilities have been incorporated in the equipment designed for this network. No similar provision has yet been made in the junction network although the matter is receiving urgent consideration.

## THE NEW TRUNK NETWORK

The main characteristics of the new trunk network are shown in Fig. 1. Subscribers are connected to local exchanges (l.e.), all of which have direct routes to their home g.s.c.s., where the controlling register-translators for s.t.d. traffic are located. The g.s.c.s also function as local exchanges for subscribers in the local areas in which they are situated. Direct routes are provided in the local part of the network wherever justified by the traffic, but calls may not be set up over more than two g.s.c.-g.s.c. links in tandem. Calls which cannot be completed over g.s.c.-g.s.c. links are set up over

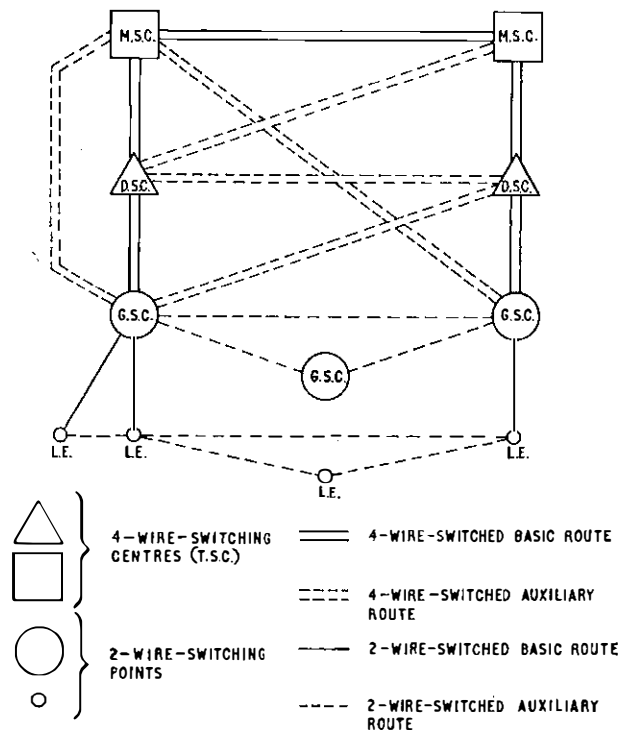

FIG. 1—Block schematic diagram of the U.K. telephone network

† Post Office/Industry Advisory Group on Telecommunications System Definitions.

the 4-wire-switched network shown in the upper part of the figure. There are two levels of t.s.c. in the network hierarchy. The lower level is composed of district switching centres (d.s.c.s), and the higher, of main switching centres (m.s.c.s). All m.s.c.s are fully interconnected by basic routes. Each g.s.c. has a basic route to its home d.s.c., and each d.s.c. has a basic route to its home m.s.c.; this basic network is supplemented by auxiliary routes between g.s.c.s, d.s.c.s and m.s.c.s as justified by the traffic. Local exchanges and g.s.c.s provide 2-wire switching, and t.s.c.s provide 4-wire switching.

The early part of the article discusses various fast-signalling techniques, and the later part examines the implications of introducing such techniques generally between register-controlled exchanges, taking account of numbering and routing aspects, interworking problems and comparative reductions in postdialling delays.

## SIGNALLING FROM SUBSCRIBERS' STATIONS

With dial-type telephones, the speed of numerical signalling is rigidly related to the speed of the dial, and routing information is transmitted to the exchange as quickly as it is generated by the user. With the advent of keyphones, it is equally desirable that information should be transmitted as quickly as it is generated, and this has led to the development of fast-signalling systems for use on subscribers' lines. Various types of d.c. and a.c. signalling systems for keyphones have been developed or proposed, and, in line with international opinion, the U.K. Post Office prefers an a.c. system. The reasons for preferring such a system are as follows:

- (a) it is suitable for direct signalling from private branch exchange (p.b.x.) extensions to the main exchange,
- (b) it has potential use for simple-data transmission from the subscriber's instrument,
- (c) it is suitable for use on subscribers' lines routed in high frequency (h.f.) transmission systems,
- (d) it has greater reliability in the presence of line-insulation and earth-resistance faults.

The selected system employs a form of multifrequency (m.f.) pulsing, using two groups of four frequencies, and each signal consists of a unique combination of two frequencies made up of one frequency from each group, as shown in Table 1. The frequencies and coding shown conform to international agreements reached by the C.C.I.T.T.\*<sup>2</sup>

**TABLE 1**  
**Allocation of Frequencies for Keyphone Signalling**

Digit	Frequencies (Hz)
1	697 + 1,209
2	697 + 1,336
3	697 + 1,477
4	770 + 1,209
5	770 + 1,336
6	770 + 1,477
7	852 + 1,209
8	852 + 1,336
9	852 + 1,477
0	941 + 1,336

An upper frequency of 1,633 Hz is also provided but will not be used initially.

The duration of each pulse is determined by the length of time for which the keyphone button is depressed. It will be noticed later that this system differs significantly from that used between exchanges. The reasons for this are partly historical and partly that:

\* International Telegraph and Telephone Consultative Committee.

(a) keyphone signal receivers are exposed to some risk of signal imitation by speech (the risk of signal imitation is, however, much less than for the in-band line-signalling systems referred to later), and

(b) a need to transmit m.f. signals in the backward direction (from the exchange to the telephone) does not arise, and thus the whole bandwidth can be used for forward signalling without any consequential inconveniences.

It is of interest to observe that the first keyphone signal has to be transmitted in the face of dial tone (or equivalent) from the exchange.

To permit the use of keyphones at some p.b.x. extensions or plan-number stations and dial-type telephones at others in the same installation, the keyphone registers at the exchange should be able to receive Strowger pulsing as well as keyphone signals.

## SIGNALLING BETWEEN EXCHANGES

At this point, it is desirable to define two basic signalling techniques. Firstly, separate-channel signalling which in this article refers to systems in which the signals relating to a number of traffic circuits are carried over paths that are completely independent of the traffic circuits and could, if so desired, be routed in different transmission systems and cables; and secondly, channel-associated signalling, which in this article refers to systems in which the signals relating to each traffic circuit are accommodated within the transmission path comprising that circuit (e.g. channel bandwidth, channel time slot) or, alternatively, are carried by a segregated path which forms an integral part of the transmission system providing the traffic circuit (e.g. one time slot in a p.c.m. system carrying the signals relating to the traffic circuits provided only by other time slots in the same system). The existing U.K. network uses channel-associated signalling almost exclusively, and it is convenient to consider this method first.

## CHANNEL-ASSOCIATED SIGNALLING

The signals which it is required to convey in a register-controlled network using associated signalling techniques may conveniently be divided into two classes:

- (a) line signals (e.g. seizure, release, answer and clear signals, which may be transmitted at any time—usually when registers are not associated with the connexions), and
- (b) interregister signals (e.g. dialled information, class-of-service and state-of-connexion signals which are transmitted only during the setting up of calls).

It is possible to use line-signalling equipment to convey both classes of signal. A simple example arises when Strowger pulsing is used between registers, in which case, the line-signalling equipment repeats the numerical information in the form of loop-disconnect pulses (or equivalent). A more sophisticated example arises in the international 2-voice-frequency (v.f.) system (C.C.I.T.T. Signalling System 4)<sup>3</sup> where the a.c. line-signalling equipment is used to provide fast inter-register signalling with automatic error detection. Typical arrangements are shown in Fig. 2(a).

In an analogue network, the use of line-signalling equipment for coded interregister signalling has several disadvantages:

(a) Special signalling arrangements (normally d.c.) must be provided to relay the coded information over the switched path between the registers and the line equipments.

(b) Because of the limited capability of d.c. techniques when used for high-speed coded signalling over inter-change circuits, relatively expensive a.c. line-signalling equipment is required on most, if not all, circuits.

(c) "Per-line" cost considerations limit the number of frequencies that may be used.

(d) Voice-immunity requirements related to supervisory signalling conditions impose restrictions on the performance of the signal receivers.

Disadvantages (c) and (d) prevent full exploitation of the bandwidth available for interregister signalling and impose signalling-speed restrictions.

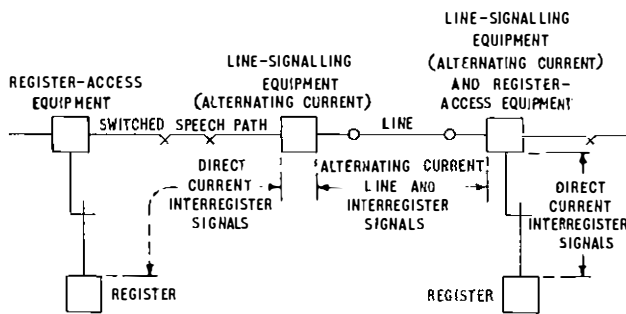

(a) Combined line and interregister signalling (typical)

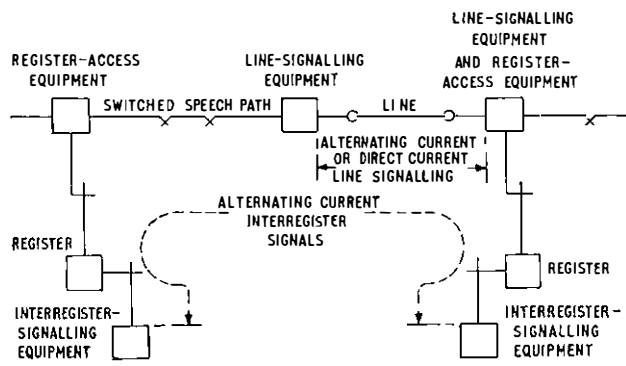

(b) Separate line and interregister signalling (typical)

FIG. 2—Channel-associated line and interregister signalling

For the foregoing reasons, in analogue networks there are advantages in providing separate equipment, associated with the registers, for interregister signalling, as shown in Fig. 2(b) and in confining the use of the line-signalling equipment to the supervisory functions. In an integrated digital network different considerations apply, and these are discussed later in the article.

### Line Signalling

When discussing fast-signalling requirements, attention tends to be concentrated on the rapid transmission of numerical information, but it is also important to ensure that supervisory signals are repeated as quickly as possible. In particular, the slow transmission of the initial answer signal over a number of links in tandem may cause loss of answering announcements, leading in some cases to the premature abandonment of calls by the called parties.

In the U.K. network, line signalling is effected by repeating the signals at each tandem switching point (link-by-link signalling), since this has the advantage that full freedom is left to use the most economical signalling systems available for the transmission media concerned; it also has the advantage that it avoids imposing serious constraints on the development of new signalling systems.

For the large number of junctions which are routed in audio frequency (a.f.) cables, d.c. signalling is the most economical technique and can readily be designed to provide an adequate speed of signal repetition.

On circuits routed in frequency division multiplex (f.d.m.) systems, in-band or out-of-band a.c. signalling may be employed.<sup>4</sup> In-band systems have the advantage that they are suitable for use over all types of circuit which have an

acceptable speech-transmission performance. They have the disadvantage that they provide a rather slow speed of supervisory signalling since relatively long response times must be incorporated to provide protection from signal imitation by speech. Out-of-band signalling is not subject to signal imitation by speech, and it is necessary to include only short delays in response time to provide immunity from the effects of false operation due to transient phenomena. As a result, out-of-band signalling is appreciably faster. It has the disadvantage that it is suitable for use only on circuits routed wholly in f.d.m. systems which incorporate out-of-band signalling as a design feature.

Line signalling on circuits routed in pulse code modulation (p.c.m.) transmission systems is normally effected by manipulating digits provided specifically for signalling purposes. This method has the advantages and disadvantages of out-of-band signalling referred to above but is faster, being at least as fast as a d.c. system.

Summarizing, d.c., out-of-band a.c. and p.c.m. line-signalling systems can be made fast enough for all practical purposes, but inband a.c. systems are rather slow, and it would be helpful from a supervisory-signalling-speed aspect if they could be gradually eliminated from the network. Unfortunately, problems associated with the economical incorporation of out-of-band signalling in f.d.m. transmission systems have so far prevented the general adoption of this method of signalling.

### Interregister Signalling

A channel-associated interregister-signalling system must be capable of functioning correctly over all types of transmission path, and this predetermines the use of an a.c. signalling technique employing frequencies in the voice band. It is desirable that the available transmission bandwidth should be adequately exploited to obtain a fast signalling speed and to provide a generous signalling capacity. Speech does not normally have access to interregister-signalling receivers and accordingly there is no need to incorporate features to provide immunity from false operation by voice currents.

Established data-transmission techniques could be employed between registers, but it is unlikely that the practical advantage in terms of reduced call-setup times relative to the m.f. pulsing technique described later, would justify the cost involved. If it is desired to exploit the capabilities of high-speed data techniques, the appropriate solution would appear to lie in the use of separate data channels, as described later in the article.

The method of interregister signalling most extensively used throughout the world is m.f. pulsing. In most, if not all, m.f. systems currently in use for interexchange signalling, each digit is transmitted as a unique combination of two frequencies out of a group of  $n$  frequencies, where  $n$  is usually five or six. Five frequencies provide only the ten decimal digits; six provide an additional five nondecimal combinations for special purposes if required.

When account is taken of the transmission performance of the various types of line plant in use and of the need to avoid false operation of in-band line-signalling equipment, the approximate bandwidth available for m.f. signalling is 500–2,000 Hz. If separate groups of six frequencies are required for signalling in each direction, the choice of frequencies after taking account of the rules to minimize intermodulation effects is strictly limited, and frequencies in the 540–1,140 Hz and 1,380–1,980 Hz bands with 120 Hz spacing between frequencies, are usually employed, as in the U.K. trunk network. Other arrangements are used in some countries. For example, in the U.S.A. where m.f. signals are transmitted only in the forward direction,<sup>5</sup> and in France, where the direction of transmission of certain frequencies is changed as the setting up of a call proceeds,<sup>6</sup> fewer frequencies are required, and 200 Hz spacing is employed.

M.F. signalling systems differ not only in respect of the frequencies used but also in the principles employed to determine signal durations. Some systems employ pulses of fixed length which may be acknowledged either separately or in groups by similar signals in the opposite direction. Other systems employ the so-called "compelled" principle in which the initial signal is maintained only until an acknowledgment signal has been received in the opposite direction, and, as soon as the resultant cessation of the initial signal has been recognized at the distant end, the acknowledgment signal itself is disconnected.<sup>7</sup>

On connexions with short propagation times, there is little difference between the speeds attainable using either pulse or compelled codes, but on connexions with long propagation times, such as are found in networks serving large geographical areas, or which contain loaded a.f. line plant, pulse codes are appreciably faster. Compelled codes are slightly more reliable on connexions which are subject to transient interruptions of the transmission path, and, when suitably exploited, can be of assistance in overcoming the effects of signal interference due to noise.

Both pulse and compelled systems may be arranged to provide error detection by designing the m.f. receiver logic to check that two, and only two, frequencies have been received in each signal and by suitable use of the acknowledgment signals in conjunction with pulse counting.

In the application of m.f. signalling to a register-controlled network, two arrangements are possible:

(a) All the information required for the subsequent routing of a call may be passed forward from switching centre to switching centre as the call progresses ("link-by-link" signalling).

(b) The originating register may send to each intermediate switching centre in turn sufficient numerical information to enable an outgoing route to be selected at that centre, the information required by the terminal centre for the subsequent connexion of the call being transmitted directly from the originating register to the terminal register over the switched connexion between the two ("end-to-end" signalling).

Link-by-link signalling minimizes receiver-design problems since the signals are regenerated at each switching point. Alternatively, end-to-end signalling, by avoiding the need for reception, storage and retransmission of through signals at each switching centre, minimizes the probability of functional failures and provides a faster speed of signalling. End-to-end signalling also greatly reduces register costs at intermediate (transit) switching centres, since both the register-holding times and the amount of equipment in the registers are much reduced. The general arrangements are shown in Fig. 3.

The m.f. system employed in the U.K. trunk transit network

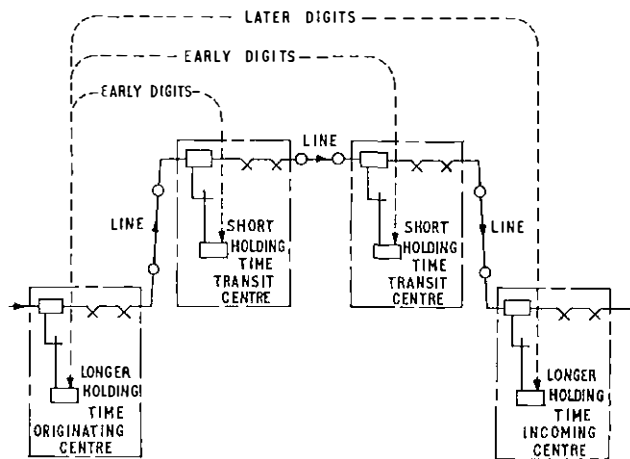
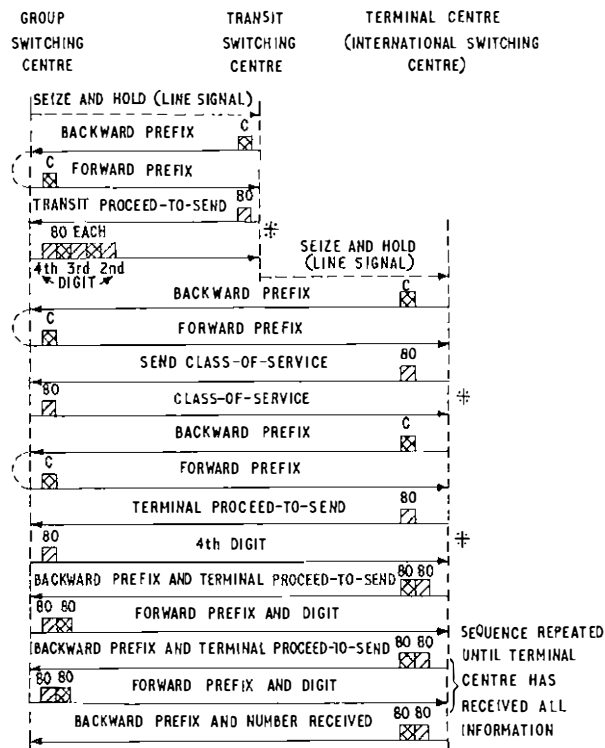

FIG. 3—End-to-end interregister signalling

makes use of both compelled and acknowledged pulse sequences and operates on an end-to-end signalling basis between g.s.c.s (or the equivalent, e.g. international switching centres). The allocation of frequencies is given in Table 2, and the general structure of the signal code is indicated by the example in Fig. 4 which shows the signalling sequences used



Note C indicates compelled sequence: figures show duration in milliseconds  
\* These sequences follow the prefix sequences without any intervening gaps

FIG. 4—Transit network m.f. signal code (i.s.d. call)

on an i.s.d. call set up by the register-translator equipment at a provincial g.s.c. and routed via one t.s.c. At most g.s.c.s, access to the transit network is provided via step-by-step selectors which introduce base-metal wiper-bank contacts into the signalling path, and it has been necessary to incorporate features to safeguard the receivers against false operation by the microphonic noise which is sometimes generated at such contacts. These guarding features also minimize the risk of false operation by switching surges and line noise. To provide this protection, it is arranged that in the idle state the receivers will respond only to the frequency combination which comprises the prefix signal, but, having once recognized this signal, the receivers are fully activated and will recognize any m.f. signal combination in the code. After a specified delay period following the cessation of a signal, the receivers revert to the guarded condition, and accordingly it is necessary to ensure in all signal sequences that the prefix signal is followed within that delay period by the functional signal. In a network composed wholly of switching systems providing high-quality speech-path connexions such as reed-relay electronic systems and certain crossbar systems, some simplification of the code might well prove possible.

An m.f. signalling system which has been developed jointly by a number of European countries, and which uses the compelled principle, has now been standardized for regional use on international circuits by the C.C.I.T.T. (the C.C.I.T.T. Signalling System R2).<sup>8</sup> The system uses the same frequencies and the same frequency allocations as does the U.K. transit network system (Table 2) and is designed for end-to-end signalling over connexions involving up to four links in tandem.

**TABLE 2**  
**Allocation of Frequencies in U.K. Trunk Transit Network**  
**M.F. System**

Signal number	Frequency combinations	
	Forward-direction signals	Backward-direction signals
	Hz	Hz
1	1,380 + 1,500	1,140 + 1,020
2	1,380 + 1,620	1,140 + 900
3	1,500 + 1,620	1,020 + 900
4	1,380 + 1,740	1,140 + 780
5	1,500 + 1,740	1,020 + 780
6	1,620 + 1,740	900 + 780
7	1,380 + 1,860	1,140 + 660
8	1,500 + 1,860	1,020 + 660
9	1,620 + 1,860	900 + 660
10	1,740 + 1,860	780 + 660
11	1,380 + 1,980	1,140 + 540
12	1,500 + 1,980	1,020 + 540
13	1,620 + 1,980	900 + 540
14	1,740 + 1,980	780 + 540
15	1,860 + 1,980	660 + 540

Whatever basic m.f. signalling system is adopted, the full signal allocation cannot be determined without regard to the numbering-scheme and routing-plan aspects, to which reference is made later.

### Signalling over Digital Transmission Links

In the 24-channel p.c.m. systems currently being brought into use in the U.K.,<sup>9</sup> each channel slot accommodates eight bits, seven of which are used for general transmission purposes and one for signalling ("in-slot" signalling). A 30-channel 32-time-slot p.c.m. system which is being standardized for use on the Continent, and which may soon be adopted in the U.K., also provides eight bits per channel slot and, in addition allocates one time slot (number 16) exclusively for signalling purposes. By the application of multiframing techniques, this time slot provides signalling bits for all 30 speech channels ("bunched" signalling). In the 32-time-slot system, all eight bits per channel are available for general transmission purposes if required. Alternatively, if seven bits suffice for transmission, the eighth bit may be used for in-slot signalling, as in the 24-channel system.

The signalling arrangements described above make adequate provision for line signalling. Interregister signalling on connections using p.c.m. circuits may be effected by using the m.f. systems described earlier in the article or by using separate channel signalling as described later; but, in a wholly digital network employing integrated p.c.m. transmission and switching, there would appear to be some advantage in using the channel bits for this purpose. The use of m.f. pulsing would entail the provision of digital-analogue converters in the registers—a requirement which it is desirable to avoid in a wholly integrated digital network—and the use of separate-channel signalling entails complications which may not be offset by compensating economic advantages, particularly if non-processor-controlled switching is employed.

During call setup, all eight channel bits are available for signalling purposes, and, in a wholly integrated digital network, some or all of these could be manipulated in the registers to provide fast coded interregister signalling. After the establishment of conversation conditions, the normal in-slot or bunched signalling bits could be used for line signalling. The per line signalling costs with such an arrangement could be relatively small, and it is difficult to see how m.f. or separate-channel signalling could compete economically, except possibly in processor-controlled exchanges where separate-channel signalling could offer other advantages, as described later. In practice, since analogue switching and transmission

systems are likely to continue being installed, at least for a number of years, and are likely to remain in service for many more years, the prospect of achieving a wholly integrated digital network in the foreseeable future appears extremely remote unless it is provided on the overlay principle, and, even then, extensive interworking requirements with the existing network are likely to arise.

### SEPARATE-CHANNEL SIGNALLING

In its simplest form, separate-channel signalling may be used to provide line-signalling facilities only. An early example, still in use on a few Strowger pulsing routes, is the employment of v.f. telegraph equipment to provide signalling equipment for groups of up to 24 traffic circuits. Today, thoughts turn to the use of data-transmission techniques to provide separate

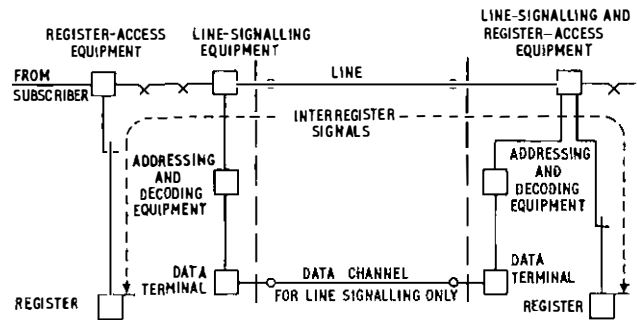

(a) Separate channel used for line signalling only

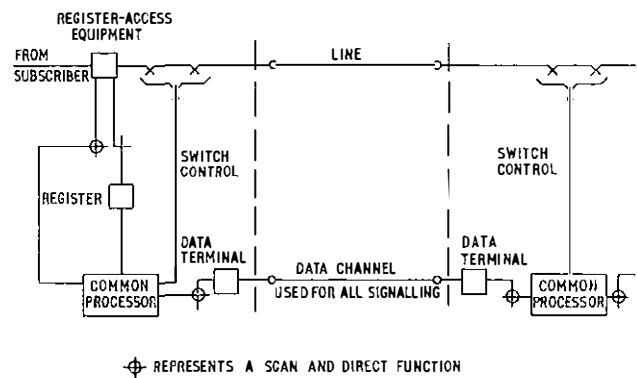

(b) Separate channel used for line and interregister signalling

FIG. 5—Separate-channel signalling principles

signalling channels capable of catering for hundreds of traffic circuits. Such an arrangement could be used in association with m.f. interregister signalling, as shown in Fig. 5(a). It will be noticed that line-signalling terminations are required on a per-line basis, but, since they do not require signalling elements on the side line, these terminations would be appreciably less expensive than the equivalent equipment on trunk circuits using channel-associated a.c. signalling (in-band or out-of-band). It is questionable, however, whether, overall, they would be significantly less expensive than the simple d.c. signalling terminations which could be used for line signalling on audio-frequency circuits (which greatly preponderate in the junction network). It is necessary to weigh against any savings in "per-circuit" signalling costs the cost of the data circuit and data terminals and of the addressing and decoding equipment. It is also necessary to take account of the cost of any changeover arrangements to secure the service against breakdowns of the signalling circuit or associated common equipment. Such a signalling system might offer economic advantages on large groups of circuits, which would otherwise need to be provided with channel-associated a.c. signalling, but it is difficult to see how it could compete economi-

**TABLE 3**  
**Separate-Channel Signalling: Format of Initial Address Message Containing Three Signal Units**

Initial Signal Unit	X X X X X X X X X X / X X X X / X X X X / X X X X X X X
	* label heading initial signal unit check
1st Subsequent Signal Unit	X / X X X / X X X X X X X X / X X X X / X X X X / X X X X X X X
	* † other routing information 1st address signal 2nd address signal check
2nd Subsequent Signal Unit	X / X X X / X X X X / X X X X / X X X X / X X X X X X X
	* † 3rd address signal 4th address signal 5th address signal 6th address signal check

\* Label indicator  
 † Length indicator

cally on small routes of this type or on most routes that could be equipped with simple d.c. signalling.

The most promising field for the general application of separate-channel data-link signalling lies in its use to convey both line and interregister signals between processor-controlled exchanges. The arrangement is shown in outline in Fig. 5(b). It will be noticed that the need for per-line signalling equipments on trunk and junction circuits may disappear completely, with consequential economies (this depends on the design of the switching system). Signalling information is communicated directly between the data links and the common processor; the latter being the ultimate source and destination of such information whatever method of signalling is used. It may be noted, however, that on tandem switched connexions it is necessary to relay signals from one separate-channel system to another via the processor, and this entails retaining in the processor complete details of all the tandem connexions which exist through the exchange at all times or, alternatively, interrogating the switching network to obtain the required information every time a through signal has to be relayed across the exchange. It may also be noted that a need arises for means to connect the processor to the particular data link serving a speech channel when it is required to transmit a signal relating to that speech channel, and this entails the provision of a high-speed connexion capability with queueing facilities between the processor and the multiplicity of data links which terminate at each switching centre. Such a capability could typically be provided by the use of scan-and-direct principles in conjunction with the use of buffer stores. Although the arrangements just described reduce, and possibly eliminate, per-line signalling-equipment costs, there are strong arguments for providing a simple means of checking the continuity of the transmission path after each call has been set up, and this entails the provision of access for the temporary connexion of some form of within-channel signalling.

At non-processor-controlled exchanges, the need to provide means of directing the information contained in data-link signals to, or from, the appropriate registers and, in the case of tandem connexions, to transfer such information across the exchange raises some doubts as to whether the use of separate-channel data links could provide an economically acceptable solution in these conditions.

Whatever types of exchange are employed in the network, the cost of the data links (including their terminal equipments) and of the arrangements for automatic changeover to reserve data systems in the event of failures make it unlikely that this method of signalling could be applied economically without further elaboration to the large number of small routes that exist in the network. To overcome the problem presented by small auxiliary routes, it has been proposed that data-link signals relating to traffic on such routes should be transmitted indirectly via one or more other switching centres so chosen as to enable data links to be used which can be loaded up

economically. The signals would then traverse a completely different path from the speech connexion. As an ultimate extension of this principle, it has been suggested that a completely separate network with its own routing principles might be established for separate-channel signalling purposes.<sup>10</sup>

The arrangements just described would not be readily applicable to the considerable number of small basic routes between small local exchanges and their g.s.c.s, since, in general, no alternative routings for the separate-channel signals would exist, and other arrangements have been suggested. It has been proposed that such small switching units might eventually take the form of slave units, dependent for their switching control on the common processors at the g.s.c.s, and that the common processors would exercise this control over secured data links. The cost of the data links might then be borne by the savings in switching-control equipment at the slave units, and the use of the links for separate-channel signalling purposes would be an implicit feature of the scheme.

Separate-channel data signalling, in addition to providing error correction, offers the following advantages over the channel-associated analogue techniques described earlier:

- (a) a greatly enhanced signalling capacity, particularly for line signals,
- (b) a faster signalling speed, and
- (c) a means of conveying network-management signals at minimal additional cost

It is unlikely that there would be any significant advantage in respect of (a) and (b) when compared with channel-associated fast digital signalling in a wholly integrated p.c.m. network. Indeed, the signalling speed would, in general, be slower owing to the scanning and queueing requirements which arise through signals at each intermediate switching centre with a separate-channel system.

The C.C.I.T.T. has produced a specification which describes in great detail the manner in which data links should be used to provide separate-channel signalling facilities between international exchanges (C.C.I.T.T. Signalling System 6).<sup>11</sup> It does not, however, describe in detail how the data system should be embodied in the switching equipment, since the design of the switching systems used at international exchanges is a matter for the individual administrations concerned. The principle features of the system described in the specification are summarized below.

The data links will operate at a speed of 2,400 bit/second using the 4-phase-modulation technique and may be provided by channels in transmission systems having a spacing of 3 kHz or more. Each message is built up of signal units composed of 28 bits each: eight of which are used for error-detection purposes and the remaining 20 for the transmission of signalling information. Since 11 of the 20 information bits in the initial signal unit (i.s.u.) are required to identify the circuit to which

a message relates, leaving only nine for functional purposes, provision is made for multi-unit messages in which subsequent signal units (s.s.u.s), coupled to the i.s.u. containing the circuit-identity label, can use all 20 bits for functional purposes. An initial address message can consist of from two to five coupled-signal units. The format of a multi-unit message is shown in Table 3.

Error control is achieved by transmitting signal units in blocks of 12, each block containing 11 signal units relating to telephone circuits and the other unit acts as an acknowledgment-signal unit. The latter contains information as to whether or not each of the 11 signal units in the block just received at the transmitting centre from the distant centre contained an error. At each data terminal, a store must be provided of sufficient capacity (taking into account the transmission time of the signalling link) to enable retransmission to occur when errors are indicated. Features are also included to detect failures of the data-carrier signal. If the data channel fails completely or if the error rate becomes excessive, arrangements are made, for the period of the breakdown, to transmit the data over an alternative path, which may be a nominated direct circuit between the two exchanges concerned or possibly an indirect connexion using data links serving other switching centres. The specification calls for tests to confirm the continuity of the speech path on each connexion prior to the commencement of conversation, and for this purpose a tone of 2,100 Hz will be used.

### NETWORK CONSIDERATIONS

The economic application of fast signalling techniques to the U.K. network, which is a large network having an established numbering and routing structure and is composed predominantly of step-by-step switching with Strowger pulsing between exchanges, gives rise to a number of considerations which are now briefly discussed.

### Numbering and Routing

The requirements examined in this section are principally of interest when non-processor-controlled exchanges are used; in a network consisting wholly of processor-controlled exchanges, it is to be expected that they could readily be accommodated by additions to the software. The signalling implications are examined in the context of m.f. signalling, but comparable requirements would arise if other methods of fast signalling were used.

In the 4-wire switched transit network, the second, third and fourth digits of the national number identify the objective g.s.c. and are sufficient to enable any t.s.c. to select one appropriate outgoing route. Some g.s.c.s serve more than one number-group area, and hence it is necessary to send the fourth digit to the terminal g.s.c. for area identification, after which the remaining digits are sent for normal call-completion purposes. It will be seen from Fig. 4 that a t.s.c. returns a transit-proceed-to-send signal to obtain the second, third and fourth digits, which are sent in a continuous train, and the terminal g.s.c. (or equivalent) calls for the fourth and subsequent digits one at a time by means of terminal-proceed-to-send signals.

The conditions in the junction network are more diverse and require a number of different sending sequences. At the present time, a call may be set up by dialling one of the following, depending on the location of the objective exchange and the junction network configuration:

- the directory number ( $N_1N_2 \dots$  etc.),
- a local code ( $C_1C_2 \dots$  etc.) plus the directory number, or
- the national number ( $OABCDEN_1N_2 \dots$  etc.).

Fig. 6 shows a typical situation in a director area; using register-controlled switching systems, the following sending requirements could arise on calls from exchange A under end-to-end interregister signalling conditions:

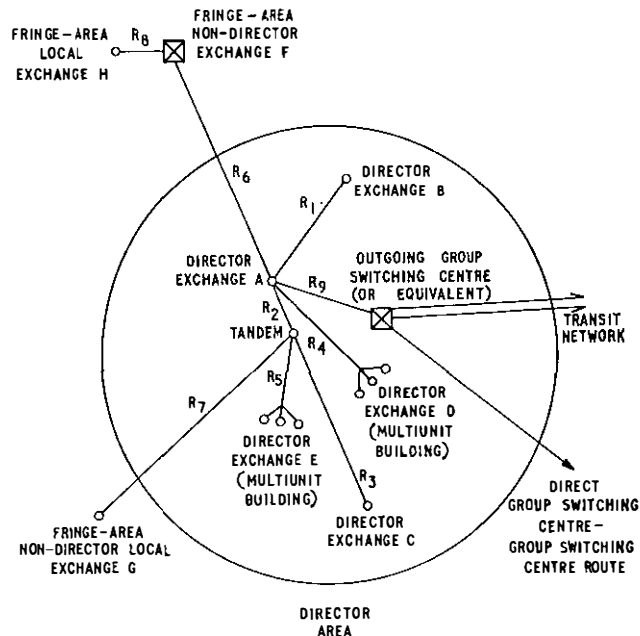

FIG. 6.—Typical director-exchange call routings

#### To exchange B

Omit the first three digits of the directory number and send the remainder  $N_4N_5 \dots$  etc. over route 1 ( $R_1$ ).

#### To exchange C

Send the first three digits of the directory number  $N_1N_2N_3 \dots$  etc. over route 2 ( $R_2$ ) and, after completion of tandem switching, the remaining digits  $N_4N_5 \dots$  etc. over routes 2 and 3 ( $R_2 + R_3$ ).

#### To exchange D

Send the full directory number  $N_1N_2 \dots$  etc. over route 4 ( $R_4$ ).

#### To exchange E

Send the first three digits of the directory number  $N_1N_2N_3$  over route 2, and, after completion of tandem switching, send the full directory number  $N_1N_2 \dots$  etc. over routes 2 and 5 ( $R_2 + R_5$ ).

#### To exchange F

Omit the code digits  $C_1C_2 \dots$  etc., and send the full directory number  $N_1N_2 \dots$  etc. over route 6 ( $R_6$ ).

#### To exchange G

Send the local-code digits plus the first digit of the directory number  $C_1C_2N_1$  over route 2, and, after completion of tandem switching, send the full directory number  $N_1N_2 \dots$  etc. over routes 2 and 7 ( $R_2 + R_7$ ).

#### To exchange H

Omit the code digits  $C_1C_2 \dots$  etc., and send translation digits  $T_1T_2$  over route 6. After completion of tandem switching at exchange F, send the full directory number  $N_1N_2 \dots$  etc. over routes 6 and 8 ( $R_6 + R_8$ ).

#### S.T.D. call

Send all digits following the prefix O, i.e.  $ABCDEFN_1 \dots$  etc., over route 9 ( $R_9$ ).

The conditions arising in non-director number-group areas are more numerous and give rise to a greater variety of digit sending requirements. Fig. 7 shows the types of routing in a number-group area bordering a director area, but a detailed examination will not be given here.

It would be possible to use different proceed-to-send signals to indicate each of the various sending requirements which arise in the network, but this would involve providing incoming-register equipments, by path-of-entry or other means, with a knowledge of the type of exchange from which each call had arrived and designing the outgoing registers to



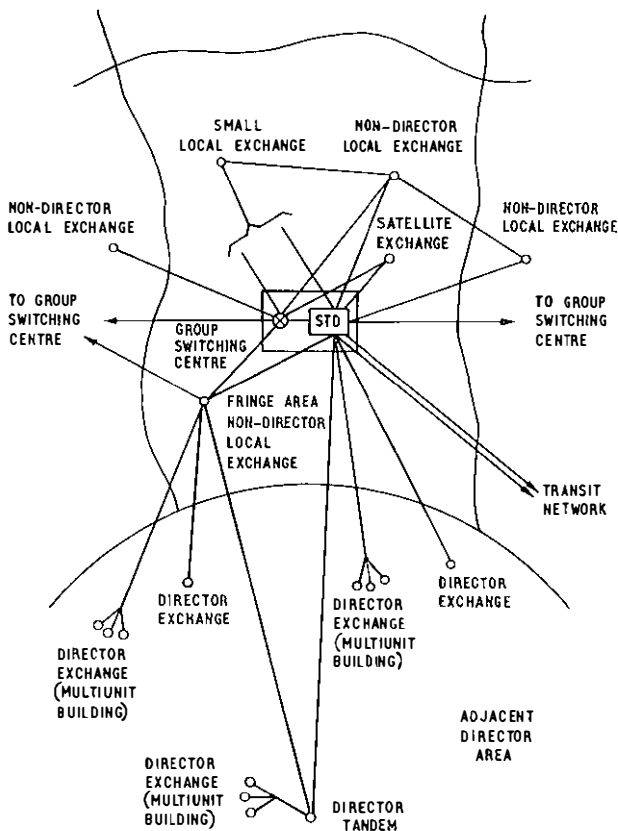

FIG. 7—Typical non-director exchange call routings

behave in different ways on receipt of these signals. Alternatively, it would be possible to use only a single proceed-to-send signal and to arrange for the outgoing registers to determine, from an analysis of the dialled digits and a knowledge of the routings involved, the information to be sent in response to each such signal. A more economical approach would appear to lie in a judicious combination of the two techniques, possibly using two proceed-to-send signals (send-early-digits and send-late-digits) in conjunction with a small digit-analysing capability in the outgoing registers. Such an arrangement would be highly compatible with the arrangements already adopted in the transit network and could ease the interworking problems which are described later.

The discontinuance of local-code dialling would greatly assist in simplifying digit-sending requirements. For example, by the elimination of local-code dialling and the use of two proceed-to-send signals as described, the only requirement in the originating registers for the director example shown in Fig. 6 would be to absorb the prefix 0 on s.t.d. calls. Thereafter, on all calls, the procedure would be the same: send the first three stored digits in response to the send-early-digits signal and the remaining digits in response to the send-late-digits signal (where the full directory number is required, it would be convenient to request the information in two parts). The gradual elimination of code dialling is desirable on service grounds, and the use of fast signalling assists in the attainment of this objective, since it facilitates the rapid connexion via the g.s.c. of s.t.d. calls from local exchanges after such calls have been delayed for digit examination to determine whether direct routes are available.

### Interworking

A large and complex network is resistant to change, since cost considerations prevent the extensive scrapping of obsolescent plant, the performance of which may not be fully compatible with the introduction of new techniques. Any new equipment brought into service as an integral feature of the present network must interwork fully with existing systems,

and the characteristics of these systems may impose limitations, the effects of which remain long after the limitations themselves have disappeared. The need for new systems to interwork with existing plant, and with each other, can present problems at least as great as those encountered in developing the new systems themselves.

The greatest impediment to the speeding up of connexion times is presented by the very large amount of step-by-step switching equipment which exists in the present network—there is little advantage in providing fast signalling from subscribers' installations and between exchanges if the fast signals have to be converted to Strowger pulses at the input to each switching unit. Most new exchanges now coming into service employ fast-switching techniques (electronic or cross-bar), but it is clear that for many years they will operate in an environment of step-by-step exchanges. It is an unfortunate fact that, in such a situation, the provision of fast signalling at new exchanges involves immediate expenditure, whereas the compensating economies, resulting from reduced holding times of line plant and register equipment, are not realized until a significant part of the network has been converted to the new method of operation.

The provision of fast signalling to and from new exchanges will give rise to a requirement for fast-signalling Strowger-pulsing conversion, and vice versa, either at tandem switching points or at the step-by-step exchanges to which the tandem switching points have direct routes. The ultimate extent of this requirement during the long changeover period may be appreciated from inspection of Figs. 6 and 7. The provision of registers to perform this conversion at terminal step-by-step exchanges would involve widespread cost penalties and possible accommodation problems. The preferable alternative of providing the conversion at those tandem-switching points which employ register-controlled fast switching would nevertheless unavoidably increase the cost of tandem registers by necessitating additional signalling elements and additional digit storage; it would also necessitate the provision of considerably more registers at tandem switching points than would otherwise be required, since it would preclude the use of end-to-end signalling on the affected calls.

As an example of specific interworking problems, it is of interest to consider what provision would need to be made in the originating s.t.d. equipments at g.s.c.s (of which some 400 are now planned or in service) if fast-signalling systems of different types were introduced into the junction network.

Considering first the use of m.f. signalling, it would be necessary to incorporate in the controlling s.t.d. equipment means to receive m.f. signals over incoming junctions, since such provision does not exist at present. Facilities already exist for using the transit network m.f. system shown in Fig. 4 over outgoing trunk circuits, and, with some modifications to the equipment, the same system could be used over outgoing junction circuits. Such an arrangement would clearly have economic advantages. Furthermore, access to the junction network is provided via step-by-step selectors, and the transit network system has been designed for use over connexions involving such selectors. On the other hand, this system is slower than a system intended for use in a network composed wholly of electronic or crossbar exchanges need be and, once adopted, could remain in existence long after the step-by-step exchanges, which necessitated its adoption, had been recovered.

Considering now the use of separate-channel signalling, severe interworking problems would arise at existing g.s.c.s, all of which are equipped with non-processor-controlled switching systems. Fig. 8 shows the conditions applying. It would be necessary to devise some method of conveying signalling information directly between the data links (serving both incoming and outgoing junctions) and the register equipment and of ensuring that the information was correctly associated with the connexions to which it related. It would also be necessary to provide signal-conversion capabilities to

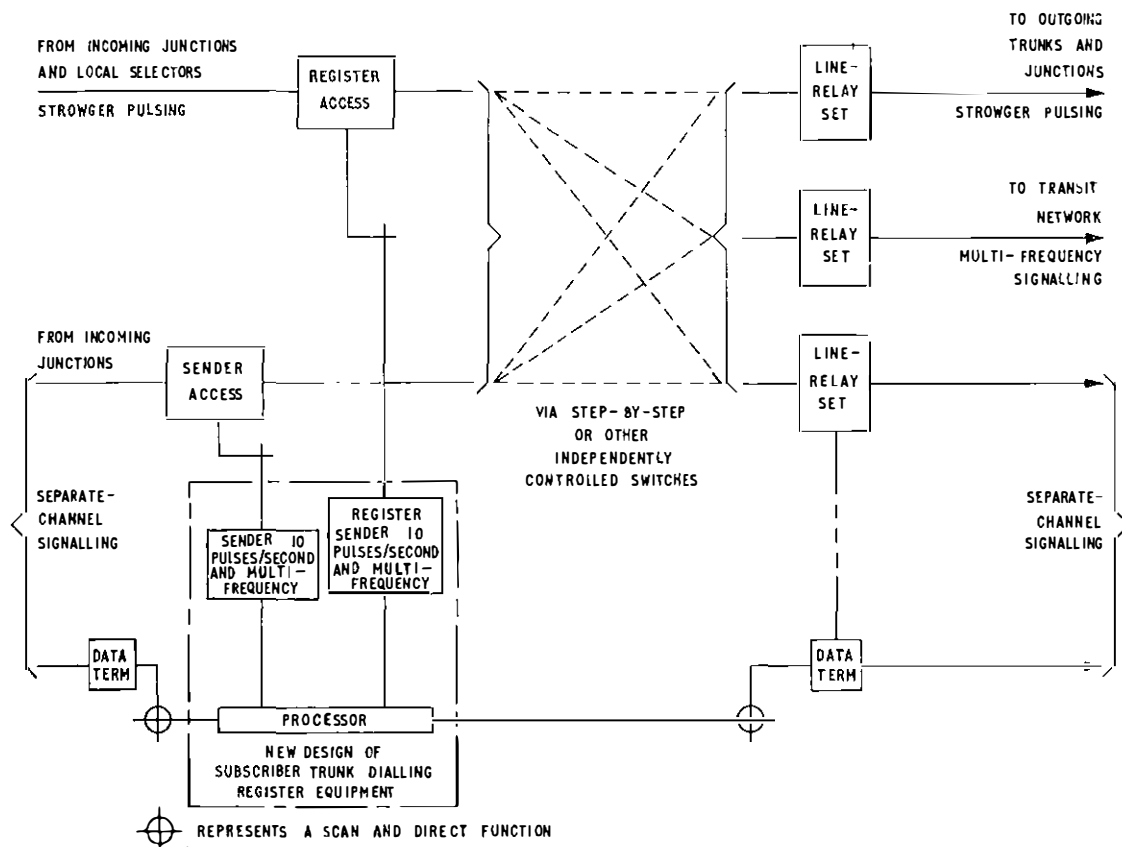

FIG. 8—Typical provision for separate-channel signalling in originating s.t.d. equipment at g.s.c.s

permit the interconnexion of circuits using Strowner pulsing, m.f. signalling and separate-channel signalling in any combination required. These requirements collectively would necessitate complete redesign and replacement of the controlling s.t.d. equipment.

Considering, finally, the use of fast-digital signalling over p.c.m. links, equally severe interworking problems would arise. During the very long changeover period, when analogue circuits and digital circuits had to co-exist and when many analogue switching centres (including all the existing g.s.c.s) had to remain in service, it would be necessary either to forego fast signalling on all analogue routes or to introduce two forms of fast signalling (say m.f. and digital), with consequential conversion requirements and cost penalties. The problem of controlling the channel bits directly from the registers over the analogue switched paths to the junction terminations would also have to be solved; the situation being similar in principle to that shown at the outgoing exchange in Fig. 2(a) but presenting greater technical problems.

From the limited examples given, which are typical of other interworking situations, it is apparent that the most economical technique for the introduction of fast signalling as an integral feature of the existing junction network is multi-frequency, and investigations are in hand to assess the practicability of adopting arrangements which could interwork with distant terminals using the transit network system and would also be capable of being speeded up by optional connexions when interworking with other new terminal equipments over transmission paths not routed via step-by-step selectors.

The need for new systems to be interconnected to each other at tandem switching points is a factor which needs to be fully taken into account. Each new system gives rise to conversion requirements, the number of which increases rapidly with the number of systems. It is most important, therefore, to avoid proliferation of interregister signalling systems and to establish that any new system which may be

adopted is economically acceptable for use on all the different types and sizes of routes which exist in the network.

### Overlay Techniques

It is possible that the method of bringing into use separate-channel signalling, or fast digital signalling, most likely to prove economically acceptable would be to provide a new overlay network completely separate from the existing trunk and junction networks but making contact with them at selected points. If the current rate of expansion of the telephone service is maintained, such a network, once the technical and economic problems have been resolved and the necessary development work completed, could grow very rapidly.

The complex interconnexion patterns shown in Fig. 6 and Fig. 7 extend across the whole country to form a single homogeneous system involving the use of hundreds of thousands of circuits, and the complete provision of a second network following the same routing pattern would present many problems and take a very long time. It may well be, however, that the reduced cost of modern transmission systems will facilitate the adoption of a more simple routing pattern for an overlay network, typically by removing the economic justification for the large number of auxiliary routes which form an important feature of the existing network. This is a matter which is currently being investigated.

Whatever configuration is adopted, it will be necessary to identify the points of contact between the old and the new networks and to determine what interworking requirements still arise. Since an overlay network on the scale envisaged could be provided only gradually over a number of years, a need would frequently arise, at least during the build-up period, for calls to pass from the new network to the old and vice versa—a factor that will need to be taken into account in identifying the points of contact. It will also be necessary to devise means whereby additional controlling s.t.d. and i.s.d. equipments and incoming decoding equipments, all of

new design, could be incorporated at g.s.c.s (or equivalent) within the overlay network at an acceptable cost and to determine what provision should be made for access to manual-board services. These matters are also under investigation.

It has been suggested that, as a first step in the provision of an overlay network, the principle could be applied to the main trunk routes between large centres of population, thus enabling the maximum benefits to be obtained from the new network at an early stage. In the absence of any segregation of either originating or terminating overlay traffic in the junction networks, it would still be necessary to make extensive modifications to the g.s.c. equipment, as described and typified in Fig. 8, but, during this initial phase, these changes would be confined to g.s.c.s, and possibly t.s.c.s, depending on the extent of the application. Unfortunately, subscribers on local exchanges with fast-switching systems would be denied the speed advantages of the overlay trunk routes where a need arose to extend calls at either end over junctions using Strowger pulsing. The provision of fast signalling in the existing junction network by the use of, say, an m.f. system could therefore be a complementary activity proceeding in advance of, and concurrently with, any application of the overlay technique to the main trunk routes; it would, however, lead to a further interworking requirement at g.s.c.s. All these aspects will need to be taken fully into account in reaching a decision on the provision of fast signalling and the possible contribution which could be made by the overlay principle.

### Network-Management Signals

The provision of processor-controlled exchanges with electrically-alterable programs in the processors would make it easier to change the behaviour of exchanges by remote signalling from centrally-situated control centres. The uses which might be made of this increased control flexibility have not yet been fully identified but clearly include the ability to alter the routing of calls to enable varying patterns of traffic to be handled in the most economical way and to minimize the effects of cable breakdowns etc. Initially, the signals to effect such changes might be sent under manual control, but, in the longer term, it is possible to envisage the use of strategically situated computers to maintain a continuous monitor on the state of the network and to effect any routing changes automatically. Other uses which could be made of remote signalling between control centres and exchanges include the temporary cessation and restoration of service on customers' lines, the remote readout of metering information and the remote collection of traffic-recording data.

In view of the operational importance of some of the actions to be taken, particularly under breakdown conditions, it is undesirable that management signalling should be dependent on connexions set up via the switched network. Special data links could, of course, be provided, but only at an additional cost. Alternatively, if separate-channel signalling were adopted for general use, there would normally be sufficient spare signalling capacity to enable the data signals to be interleaved with those relating to the traffic circuits, and, subject to the control centres being located on sites which had convenient access to the necessary signalling terminals, this would clearly result in cost savings.

### FACILITIES ASPECTS

All the fast interregister-signalling systems which have been described in the article provide an enhanced signalling capacity in both the forward and backward directions of signal transmission, and it is important to note that the increased signalling capacity in the backward direction is as valuable from a service aspect as that in the forward direction. The use which is made of the increased signalling capacity in both directions will depend on the customer services to be provided and the operational requirements of the network, including those needs arising from numbering and routing considerations to which

reference has been made earlier. Space does not permit an examination of all the potential uses which exist, and, for present purposes, it is sufficient to indicate generally how facility considerations may react on the provision of fast signalling.

As the facility requirements become increasingly sophisticated, the signalling information which needs to be transmitted increases. A typical example is shown in Fig. 9, which

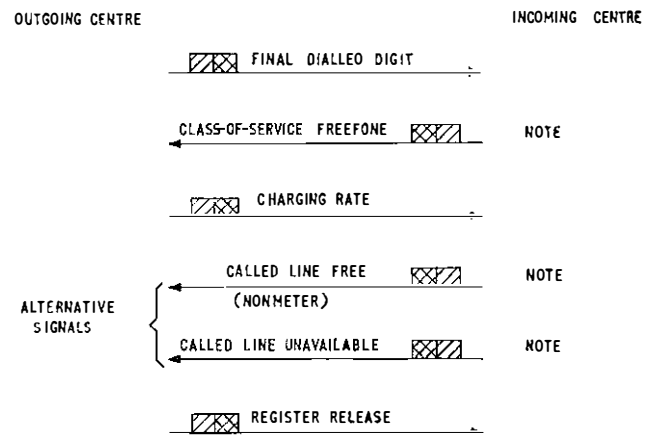

Note These sequences could be two pulse signals depending on the code  
FIG. 9—Possible m.f. sequence to provide freefone service

indicates an m.f. signalling sequence to provide a possible future form of automatic freefone service in which the called customer would agree to pay for incoming calls which did not incur a charging rate in excess of a specified value. Signalling sequences of this type, taking place after the completion of switching, would cause slight increases in postdialling delays, which might amount to several hundred milliseconds with m.f. signalling, but would be negligibly small with fast-digital (p.c.m.) signalling, or with separate-channel signalling involving only a single link. Similarly, a significant increase in class-of-service requirements, resulting in a need for multiple class-of-service signalling on particular lines, could, in the limit, introduce additional postdialling delays of up to several hundred milliseconds when m.f. signalling is used, whereas, with fast digital signalling or single-link separate-channel signalling, the extra delay would be negligible.

Possibly the greatest increase in postdialling delay, arising from a facility requirement and attributable to signalling operations, would occur if it were necessary to transmit calling-line-identification (c.l.i.) signals between registers. Such a requirement could add 1–2 seconds to the postdialling delay if m.f. signalling were used but would give rise to negligible increased delay if fast-digital signalling were used. For separate-channel signalling between non-processor-controlled exchanges, the increased delay would fall intermediately between the two, depending on the number of links involved in the connexion. If separate-channel signalling and processor-controlled exchanges were used, it is probable that the c.l.i. information could be transmitted after completion of call setup without affecting postdialling delays.

### SIGNALLING SPEEDS

#### Line Signalling

Interest centres particularly on the speed of transmission of the answer signal. The actual time taken to transmit the signal depends each time upon detailed system and component designs and, in the d.c. and a.c. examples, also upon the characteristics of the transmission lines; but the following are typical for connexions involving several links:

- (a) digital signalling (p.c.m. systems) = 0.5–20 ms per link,
- (b) d.c. signalling = 5–20 ms per link,

(c) separate-channel signalling (data link) = 20–70 ins per link,

(d) a.c. out-of-band signalling = 40–60 ms per link,

(e) a.c. in-band signalling = 100–200 ms per link.

Except for in-band signalling, the times given are typical for all other line signals. For in-band signalling, certain signals, such as the initial-seizure signal, are transmitted in conditions where imitation by voice currents cannot occur, and the time required for these signals may be of the order of only 30–50 ms per link.

### Interregister Signalling

Estimates of the speeds attainable with different inter-register-signalling systems depend not only on the detailed equipment designs but also on a number of assumptions concerning the precise ways in which the systems are used, and it is not possible to do more than give a very broad indication of signalling speeds for general comparative purposes. The following are typical of the speeds involved:

(a) Strowger pulsing (with short inter-digital pause): 1·2 digits/second,

(b) transit-network m.f. system: 3–6 digits/second,

(c) new m.f. system: 6–10 digit/second,

(d) separate-channel signalling: 25–160 digits/second,

(e) fast-digital signalling (p.c.m.): more than 1,000 digits/second.

The speed quoted for fast-digital signalling assumes a wholly integrated digital network.

The impact of these speeds on postdialling delays may be assessed by considering a hypothetical call routed through a number of register-controlled fast-switching centres. If it is assumed that, on a keyphone call involving the maximum number of switching centres, the postdialling delays would be 24 seconds if Strowger pulsing were used between registers and that, of this delay, 2 seconds would be due to factors unaffected by signalling speed (e.g. switching times, ring-tone periodicity etc.), the comparative postdialling delays using the different interregister signalling speeds listed above would be of the following orders:

(i) Strowger pulsing: 24 seconds,

(ii) transit network m.f.: 7·5 seconds,

(iii) new m.f. system: 5 seconds,

(iv) separate-channel signalling: 2·5 seconds,

(v) fast-digital (p.c.m.) signalling: 2 seconds.

Thus interregister-signalling speeds quickly reach a point beyond which further increases are of diminishing value from a service aspect. In arriving at the above figures, it has been necessary to make a number of assumptions concerning such factors as subscriber keying speed and exchange switching times and accordingly the figures should be taken only as an indication of the relative orders of postdialling delay resulting from the use of various interregister-signalling systems.

### CONCLUSIONS

Separate-channel and fast-digital (p.c.m.) signalling systems offer the prospect of faster signalling speeds and greatly increased signalling capacity; but the introduction of either system as an integral feature of the existing network would present costly interworking problems, and further study is desirable to establish the extent to which the use of overlay techniques could assist in overcoming these problems.

Before the preferred characteristics of an overlay network can be determined, it will be necessary to reach decisions on a number of fundamental features, including the routing principles to be adopted, the transmission techniques to be used and the type of switching to be employed. As a parallel and interrelated study, it will be necessary to determine the type of signalling to be used, and, in carrying out this study, account will need to be taken of the problems of interworking between the existing network and the overlay network. Fast digital signalling is unlikely to be appropriate unless it is decided

that the overlay network should take the form of a wholly integrated p.c.m. transmission and switching complex. This will need to await the development of higher-order p.c.m. multiplexes for use on long-distance routes and possibly a solution to the problem of applying p.c.m. switching economically at local exchanges. The argument for using separate-channel signalling is likely to be dependent on the adoption of processor-controlled switching throughout the overlay network, and the economic viability of such a solution may depend upon the use of centralized processors to control groups of local exchanges over secured data links.

Inevitably, some time will elapse before the studies necessary to enable final conclusions to be reached on the cost implications of all these solutions can be completed, and, assuming the outcome is favourable to the provision of an overlay network, further time will be required for development and implementation. It would seem desirable, therefore, to proceed with the introduction of fast signalling between register-controlled exchanges over the existing junction network independently of any longer-term studies related to more fundamental changes based on overlay techniques, and, for this purpose, m.f. signalling may well be the most appropriate technique.

For economic reasons, it is important that any m.f. system adopted for use in the junction network should have the greatest possible compatibility with the system already in use in the transit network. It is also very desirable that the system should be capable of operating at a faster speed than the transit network system, if possible on all types of connexion, but certainly on connexions which do not involve base-metal wiper-bank contacts. It would appear that the first objective should be to produce a system which is capable of interworking directly with the existing m.f. equipments at g.s.c.s but which, possibly by the use of optional connexions, could be speeded up when interworking over good-quality switched paths with other exchanges also provided with the new design of m.f. equipment. If this proves unattainable, the degree of compatibility, in respect of coding structure etc., should at least be such as to minimize signal-conversion costs on connexions extended over the transit network system.

### ACKNOWLEDGMENTS

Acknowledgment is given to the author's colleagues, past and present, in the Development and Research Departments of the Post Office.

This article was originally published as a paper in the *Proceedings of the I.E.E.* Permission to include it in this Journal is gratefully acknowledged.

### References

- 1 TOBIN, W. J. E., and STRAYTON, J. A New Switching and Transmission Plan for the Inland Trunk Network. *P.O.E.E.J.*, Vol. 53, p. 75, July 1960.
- 2 Technical features of Push Button Telephone Sets. C.C.I.T.T. White Book, Vol. 6, Pt. 2 (to be published).
- 3 Specifications of Signalling System No. 4. *ibid.* Vol. 6, Pt. 9 (to be published).
- 4 HORSFIELD, B. R., and SMITH, D. C. A.C. Signalling—A Review of Current Problems, I.P.O.E.E., printed paper 204.
- 5 DAHLBOM, C. A., HORTON, A. W., JUN., and MOODY, D. L. Multi-frequency Pulsing in Switching, *Elect. Engng.*, 1949, Vol. 68, p. 505.
- 6 GAZANION, H., and LEGARÉ, R. Système de Signalisation socotel, *Comm. & Electron.*, Vol. 4, p. 32, 1963.
- 7 WELCH, S. The Signalling Problems associated with Register Controlled Automatic Telephone Exchanges, *Proceedings of the I.E.E.*, Vol. 109 B, p. 465, 1962.
- 8 Specifications of Signalling System No. R2, C.C.I.T.T. White Book, Vol. 6, Pt. 16 (to be published).
- 9 BOLTON, L. J., and BENNETT, G. H. Design Features and Application of the British Post Office 24-Channel Pulse Code Modulation System, *P.O.E.E.J.*, Vol. 61, p. 95, July 1968.
- 10 LUCAS, P., LEGARÉ, R., and DONDOUX, J. Principes nouveaux pour la Signalisation Téléphonique, *Comm. & Electron.*, Vol. 18, pp. 7–23, 1967.
- 11 Specifications of Signalling System No. 6, C.C.I.T.T. White Book, Vol. 6, Pt. 14 (to be published).

# Automatic Calling and Automatic Answering for Datel Services

A. J. BOTT, B.SC.(ENG.), C.ENG., M.I.E.E., and W. C. CASTLE\*

U.D.C. 621.394.34: 621.394.63

*Since the inauguration of the British Post Office Datel Services, all outgoing data calls have been set up manually. On international routes equipped with echo suppressors, duplex operation has not been possible unless special circuits and procedures were used. This article describes equipments which enable data terminals to originate or answer calls automatically over the public telephone switching network and, where necessary, disable echo suppressors in the route to allow duplex working.*

## INTRODUCTION

When the first Datel Service was introduced, each connexion was set up by making a normal telephone call and subsequently operating keys at both ends of the connexion to associate the modems with the line in place of the telephones. A demand soon arose for incoming datel calls to be answered automatically.<sup>1</sup> This facility was provided by fitting a ringing-current detector into the telephone instrument at the answering end to extend a signal to the subscriber's data-terminal equipment (d.t.e.). In response to this signal the d.t.e. returned a signal to the modem, which caused it to be connected to line. Some modems now incorporate ringing-current detectors.

To provide confirmation to a caller that he is connected to a data terminal, a tone is transmitted from the modem when a call is answered automatically, or, alternatively, a recorded verbal announcement may be provided from a Post Office answering set. The tone or announcement also serves to indicate to any subscriber who calls an automatic-answering data terminal in error the need to clear and recall.

The arrangements described above have been provided on a national basis. To meet the need for international working, C.C.I.T.T.† have studied both automatic answering and automatic origination of data calls and have made recommendations which define the line signals and interface parameters to be used for international automatic working.

This article describes the Data-Control Equipment No. 1A (D.C.E. No. 1A) and Data-Control Equipment No. 2A (D.C.E. No. 2A), which have been developed to provide automatic-calling and automatic-answering facilities, respectively, to C.C.I.T.T. standards. Similar equipment has been

developed for use in the telex network and will be described in a later article.

## DESCRIPTION OF EQUIPMENT

Fig. 1 and Fig. 2 show the external appearance and internal construction of a D.C.E. No. 1A. The equipment is housed in a case of a design similar to that used for Datel modems and which has been adopted as the present house style for Datel equipment. The case is finished in two shades of grey, and is fitted with guides which accommodate five 62-type plug-in

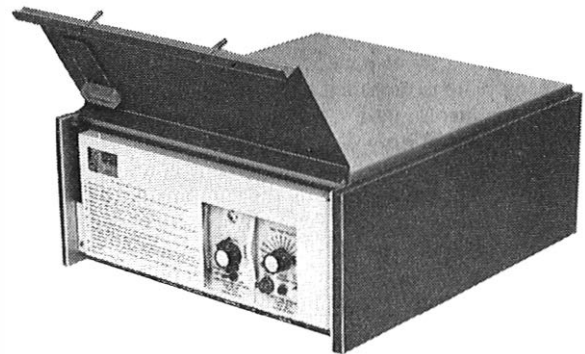

FIG. 1—Data-Control Equipment No. 1A

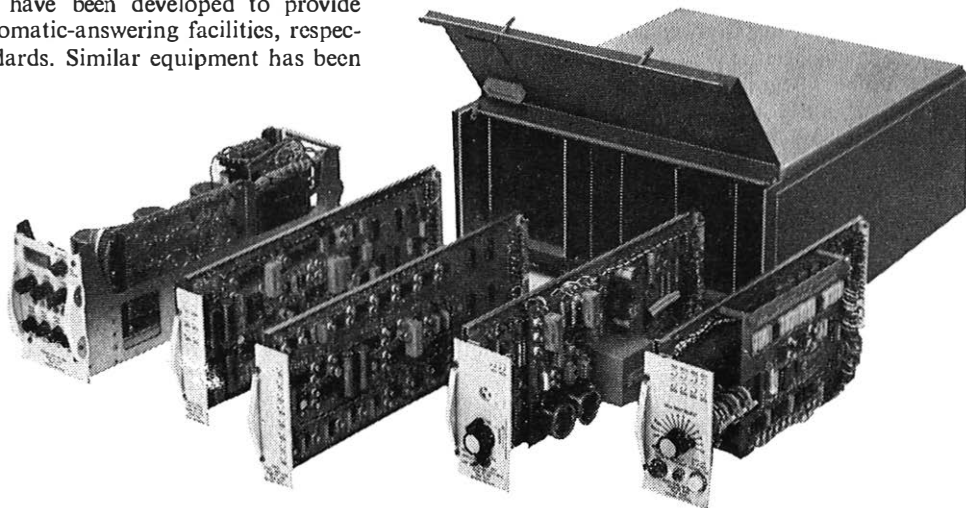
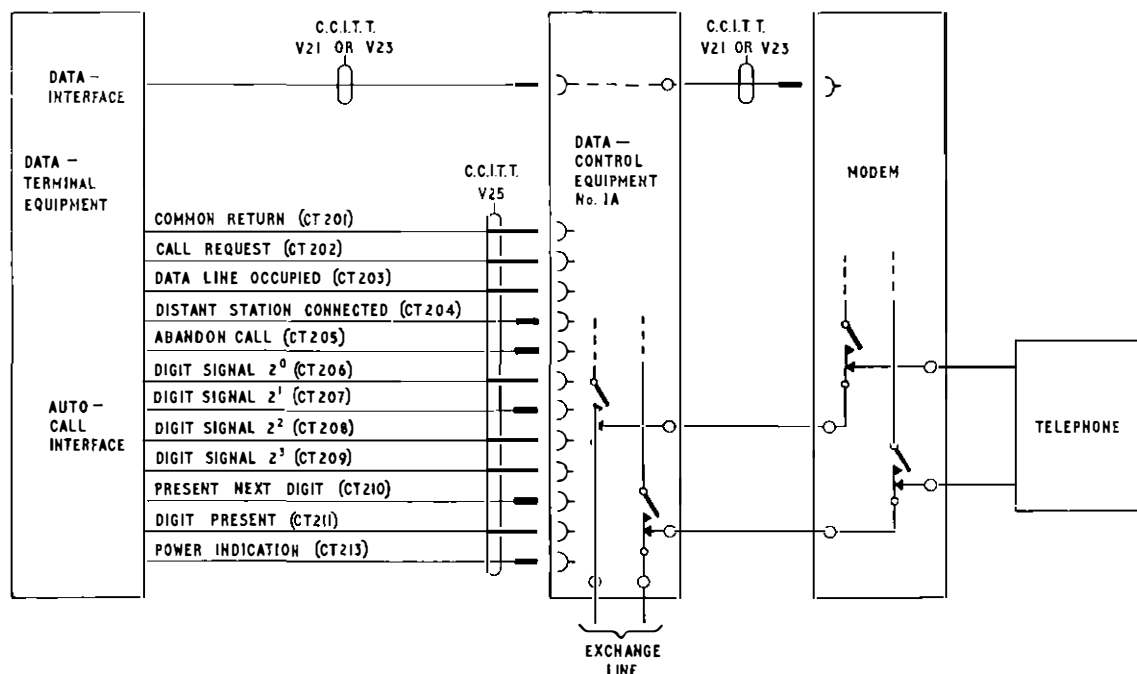

FIG. 2—Internal construction of Data-Control Equipment No. 1A

\* Telecommunications Development Department, Telecommunications Headquarters.

† C.C.I.T.T.—International Telegraph and Telephone Consultative Committee.



The CT numbers indicate the C.C.I.T.T. interchange-circuit numbers

Fig. 3—Interconnexion of Data-Control Equipment No. 1A, modem, data-terminal equipment and line

units. Four of the units incorporate double-sided printed-wiring boards on which are mounted dual-in-line integrated circuits and other components. The fifth unit is a power unit suitable for operation from 200–250-volt 50 Hz mains.

The front cover is hinged and secured by two knurled screws to permit both Post Office staff and customers to gain access to certain front-panel controls used for test purposes. A masking plate is provided to prevent customers interfering with other controls and test points which are intended for use by Post Office staff only.

Beneath its rear cover the equipment contains screw-terminal strips used for connecting the equipment to a telephone and an associated modem. Two 25-way sockets are provided on the rear of the equipment for connecting it to the d.t.e.<sup>2</sup> One carries the data interface connexions and the other carries the auto-calling interface connexions that are used to control the setting-up of a call. Fig. 3 shows the way in which the equipment is linked to a d.t.e., modem and line.

Fig. 4 and Fig. 5 show the external appearance and internal construction of a D.C.E. No. 2A. The case is similar in design to that of a D.C.E. No. 1A, but is narrower and, because no customer-operated test facility is provided, the front cover is arranged to provide engineering access only. This equipment also uses dual-in-line integrated circuits to perform logic functions and incorporates an identical power unit to that used in the D.C.E. No. 1A. In use the equipment is connected to a d.t.e., modem and line as shown in Fig. 6.

## OPERATION

Fig. 7 shows the sequence of interface signals and the timing of line signals when automatic calling and answering are employed in a system using duplex modems. The terms ON and OFF as used in Fig. 7 and in the following description are defined elsewhere.<sup>2</sup>

Before starting to originate a call the d.t.e. confirms that the D.C.E. No. 1A is available for use by checking that the POWER INDICATION circuit is ON and that the DATA LINE OCCUPIED circuit is OFF. It starts the establishment of a call by turning ON the CALL REQUEST circuit, which causes the D.C.E. No. 1A to apply a calling loop to the exchange line and, after a pause which may be preset to between 2 and 10 seconds to allow the return of dialling tone, the D.C.E. No. 1A turns

ON the PRESENT NEXT DIGIT circuit. The d.t.e. responds by presenting, in binary form on the four DIGIT SIGNAL circuits, the first digit of the number to be called and turning ON the DIGIT PRESENT circuit. The D.C.E. No. 1A now generates the appropriate number of loop-disconnect pulses followed by an interdigital pause. At the beginning of the interdigital pause the D.C.E. No. 1A turns the PRESENT NEXT DIGIT circuit OFF and waits for the d.t.e. to turn OFF the DIGIT PRESENT circuit. When this is detected it once more turns ON the PRESENT NEXT DIGIT circuit to request the second digit from the d.t.e. The foregoing procedure is repeated for each digit of the number to be called.

If the first digit is an access digit, e.g. for p.a.b.x. working, this is followed by a code representing a control character termed separator (SEP). On receipt of SEP the D.C.E. No. 1A introduces a second pause, preset to between 2 and 10 seconds, to allow the return of dial tone from the public exchange before requesting the next digit. After the last digit has been presented, the D.C.E. No. 1A makes a request for a further digit and receives binary twelve which is a control character representing end-of-number (EON). Receipt of EON causes the D.C.E. No. 1A to extend the exchange line to the modem, which it controls via the interchange circuits in such a way that it transmits an interrupted binary 1 tone to line.

The bursts of tone have a duration of 500–700 ms, and the interval between bursts is 1.5–2.0 seconds. The purpose of this calling tone is primarily to indicate to a subscriber called in error that an incorrect connexion has been established. It also enables a data subscriber who may have answered in the speech mode to recognize that he is receiving a data call and to switch his equipment into the data mode.

During the silent intervals between bursts of calling tone the D.C.E. No. 1A inspects the line for the presence of 2,100 Hz answering tone from the called station. The detection circuit is designed so that it will not respond to 2,100 Hz if it is accompanied by signals of comparable level in other parts of the speech band, nor will it respond if the duration of the received 2,100 Hz signal is less than 450 ms. The detector is not, therefore, prone to false operation by other signals which may be received, e.g. number-unobtainable tone.

Should answering tone not be detected within a period which may be preset to be between 10 and 40 seconds from the detection of the EON character, the D.C.E. No. 1A turns

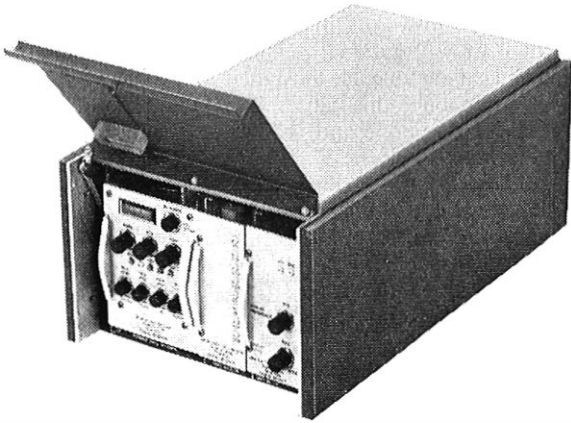

FIG. 4—Data-Control Equipment No. 2A

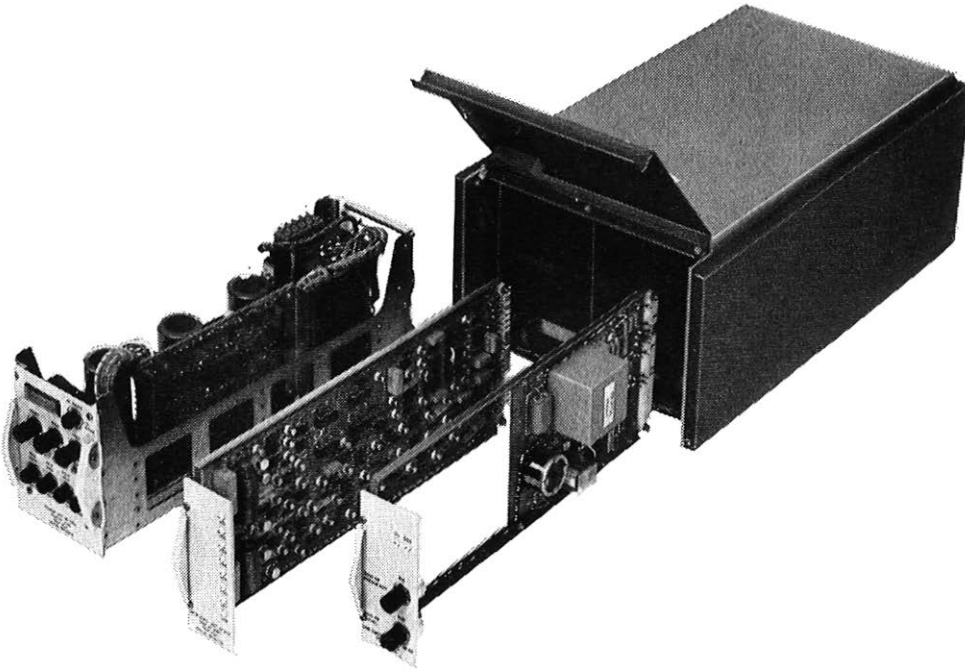

FIG. 5—Internal construction of Data-Control Equipment No. 2A

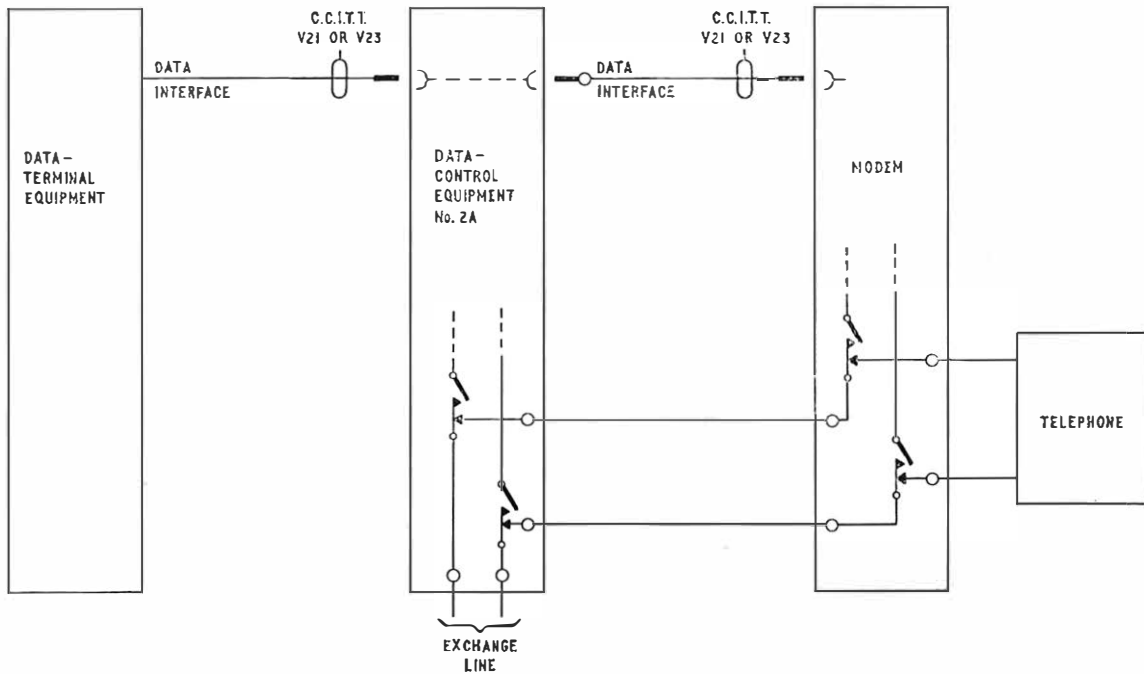

FIG. 6—Interconnexion of Data-Control Equipment No. 2A, modem, data-terminal equipment and line

ON the ABANDON CALL circuit, which advises the d.t.e. that the call has failed to mature.

If a valid answering tone is detected, the D.C.E. No. 1A immediately turns the DISTANT STATION CONNECTED circuit ON, replaces the interrupted calling tone by continuous binary 1 tone and awaits cessation of the answering tone. When the answering tone ceases, the D.C.E. No. 1A extends all the modem interchange circuits to the d.t.e. which, from that instant, must exercise control over the modem in exactly the same way as if the call had been set up manually. The holding loop on the line is maintained as long as the d.t.e. maintains an ON condition on the DATA TERMINAL READY circuit.

The procedure at the called station is that the incoming ringing current is detected and turns ON the CALLING INDICATOR circuit. This condition is detected within the D.C.E. No. 2A, which relays it to the d.t.e. If the DATA TERMINAL READY circuit is either ON or is turned ON by the d.t.e. in response to CALLING INDICATOR, the D.C.E. No. 2A answers the call by looping the line and applying a 2,100 Hz answering tone for between 3 and 4 seconds. At the end of the transmission of answering tone the D.C.E. No. 2A extends the modem interchange circuits to the d.t.e., which takes control of the modem.

Both at the calling and called stations the d.t.e. applies control to the modems so that they transmit binary 1 initially. Each d.t.e. is able to transmit data as soon as its READY FOR SENDING circuit turns ON.

The use of the foregoing procedure with an answering tone having a frequency of 2,100 Hz enables duplex transmission of data to take place on circuits equipped with echo suppressors such as the Echo Suppressor No. 7A.<sup>3</sup> These suppressors incorporate a disabling feature activated by a 2,100 Hz signal. Once disabled, the suppressors are held in the disabled state by modem tones in one or both directions. However, a break of 125 ms duration or more occurring simultaneously in both directions can restore the echo-suppressor to normal. In this event a high loss is inserted in one direction of transmission, which prevents the use of the circuit for duplex operation. There is no C.C.I.T.T. recommended procedure for recovering from this situation, and probably the most convenient method of recovery is to clear and re-establish the connexion.

Where systems operate in the half-duplex mode and employ automatic calling, it is necessary to pre-arrange which of the two stations—calling or answering—shall first transmit to the other upon establishment of a connexion. The d.t.e. which is to transmit first must turn ON the REQUEST TO SEND circuit during establishment of the call so that binary 1 is transmitted as soon as it gains control over the modem. It may send data as soon as its associated D.C.E. No. 1A or 2A turns ON the READY FOR SENDING circuit. During the automatic calling and answering procedures any echo suppressors associated with the circuit will be disabled. They may be restored during any subsequent changes of transmission direction, but this is of no consequence for half-duplex operation.

The procedure for establishment of a call from a non-automatic data station to an automatic-answering data station is similar to that from an automatic-calling data station, except that no tone is transmitted from the calling station until the called station has answered.

In order to ensure satisfactory disabling of echo suppressors by the answering tone no signals such as microphone noise must come from the calling station for a period of at least 400 ms during the receipt of the 2,100 Hz answering tone. To achieve this the manual terminal operator may disconnect the microphone, e.g. by a handset switch. When the cessation of the 2,100 Hz tone is heard the modem is then connected to line and binary 1 transmitted. Alternatively, the silent period can be obtained by waiting for the start of the 2,100 Hz tone and then switching the modem to line but delaying the application of an ON condition to the REQUEST TO SEND circuit until a specified period has elapsed.

A customer answering in speech mode an incoming call originated by an automatic-calling equipment hears the interrupted calling tone. He must then operate a key associated with his telephone; this causes his D.C.E. No. 2A to disconnect the telephone and follow the standard automatic-answering procedures.

In addition to the facility of being able to recognize a 2,100 Hz answering tone, the D.C.E. No. 1A may, if required, be wired to utilize its associated modem to recognize, as an answering tone, a binary 1 modem tone of 1 second or more in duration. This enables automatic calling to be carried out to data stations not equipped with means for generating a 2,100 Hz answering tone, and customers may therefore introduce automatic calling into their existing schemes<sup>1</sup> without the necessity for equipping all answering stations with D.C.E.s No. 2A. Disadvantages of doing this are, firstly, that the C.C.I.T.T. procedure for disabling echo suppressors is not followed, and, secondly, false operation is possible because the calling station modem cannot in many instances distinguish between a genuine modem answering tone and other signals which may be received, e.g. number-unobtainable tone.

If required a D.C.E. No. 1A and a D.C.E. No. 2A may be installed on the same line.

## TESTING FACILITIES

Comprehensive test facilities have been incorporated in the D.C.E. No. 1A for use by customers either on their own or in co-operation with Post Office staff at a test desk or a Datel Test Centre. Access to the test controls is obtained by raising the front cover after slackening two knurled screws.

Before conducting any test the customer is instructed to disconnect all privately-owned equipment by removing the interface connexions between the d.t.e. and the D.C.E. No. 1A. This ensures that conditions from the d.t.e. do not invalidate the tests. Using the test facility, a customer can manually apply signals to the interface in order to set up a call, and a lamp indication is given when answering tone is detected from the called station. A monitoring amplifier enables him to hear service-signals, speech, tones, etc., which may be present on the line during the test. The amplifier is controlled so that it will only monitor the line during the call setting-up procedure.

To make a test call, the customer first disconnects the interface to the d.t.e. and switches on the monitor amplifier. He next turns the rotary test switch to the CALL position. This simulates the turning ON of the CALL REQUEST circuit, which causes the line to be looped and dial tone to be returned from the exchange. After a short delay a green lamp designated PRESENT NEXT DIGIT begins to glow. The customer on seeing this turns the test switch to the first digit of the number to be called and presses the DIGIT PRESENT button. This causes the appropriate train of dial pulses to be generated and extinguishes the green lamp until the equipment is ready for the next digit, when the lamp re-lights. The customer presents the remainder of the digits and EON to the equipment in a similar fashion. If the equipment has functioned correctly, the customer should now hear calling tone and ringing tone for a brief period followed by answering tone which, when it has been detected will cause a white lamp, DISTANT STATION CONNECTED, to glow.

If the foregoing test is carried out successfully, it is a fairly good indication that the operation of the logic circuits and the 2,100 Hz tone detector is satisfactory.

By asking a customer to send a series of digits using the test facility, a test clerk can check the ratio and speed of the pulses generated by the equipment.

No special test facilities for customer use are provided in the D.C.E. No. 2A, since it is basically a much simpler device than the D.C.E. No. 1A. However, the operation may be verified by Post Office staff using current Datel testers.



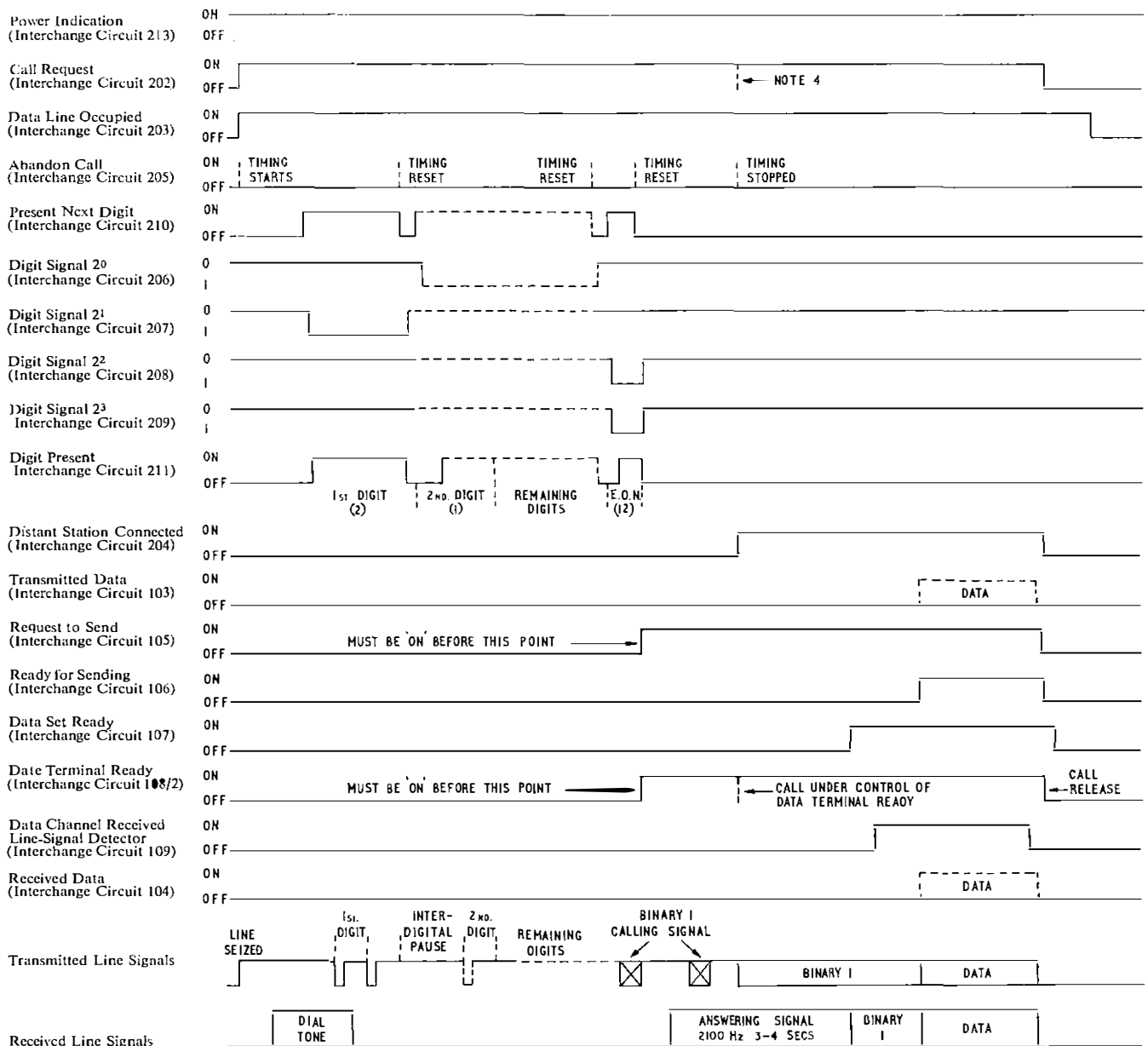

- Notes: 1 Timings not to scale  
 2 100 series circuits are used for data interface.  
 3 Numbers in brackets indicate numerical value of digit  
 4 The CALL REQUEST circuit can be turned OFF without releasing the call at any time after the DISTANT STATION CONNECTED circuit turns ON.

FIG. 7—Sequence of interface signals and timing of line signals

In addition to the test facilities described above, both the D.C.E. No. 1A and D.C.E. No. 2A have test sockets mounted on the unit front panels and suitably-located pins on the printed-wiring boards for engineering test purposes.

### AVAILABILITY AND USE

D.C.E.s No. 1A and 2A are currently available for customers' installations in conjunction with Modem No. 1<sup>4</sup>, Modem No. 2<sup>5</sup> and the standby channel of the Modem No. 7<sup>6</sup>. It is thought that the advent of the Midnight-Line service will stimulate their use in data-collection systems where out-stations compile their data during day time and store it for automatic transmission during the night. Other expected uses are to produce staff savings at installations where large numbers of calls are handled and to overcome the staffing problems caused by time differences at installations operating internationally.

### ACKNOWLEDGEMENT

The Data-Control Equipment No. 1A and the Data-Control Equipment No. 2A were developed, to British Post Office specifications, by Trend Electronics, Ltd.

### References

- COLLIER, E. G. Now Data calls are Answered Automatically. *Post Office Telecommunications Journal*, Winter, 1967.
- BOIT, A. J. Interfaces for Digital Data Transmission. *P.O.E.E.J.*, Vol. 63, p. 113, July 1970.
- HODSALL, A. G. The Echo Suppressor No. 7A. *P.O.E.E.J.*, Vol. 63, p. 86, July 1970.
- ROBERTS, L. W., and SMITH, N. G. A Modem for the Datel 600 Service—Datel Modem No. 1A. *P.O.E.E.J.*, Vol. 59, p. 108, July 1966.
- SPANTON, J. C., and CONNELLAN, P. L. Modems for the Datel 200 Service—Datel Modems No. 2A and 2B. *P.O.E.E.J.*, Vol. 62, p. 1, Apr. 1969.
- ADAMS, G. W. A Modem for the Datel 2400 Service—Datel Modem No. 7A. *P.O.E.E.J.*, Vol. 62, p. 156, Oct. 1969.

# Notes and Comments



**J. W. Whittaker, B.Sc.(Eng.), C.Eng., M.I.E.E.**

After some three years in the Personnel Department, John Whittaker has been appointed Telephone Controller, Northern Ireland. He first entered the Post Office in 1940 as a Youth-in-Training in the North Area before being called-up in 1943 to the Royal Signals. After five years he left the Army as a W.O. I Foreman of Signals and obtained an honours degree at London University. Returning to the Post Office in 1952, he was appointed E.E. in the Engineering Dept. (E.D.) S Branch concerned with telecommunications facilities for other government departments. Five years later he moved to the North Area on installation duties and in 1962 was promoted S.E.E. in the E.D. TPE Branch dealing with equipment, traffic and economic aspects of electronic exchange design. Transferring to the East Area in 1966, he became Area Engineer in charge of maintenance and in early 1968 was promoted A.S.E. in THQ dealing with the grading of minor engineering duties and negotiation with the staff associations on changes in engineering organization and practice.

John Whittaker brings to his new post, which carries responsibility for the telecommunications business in Northern Ireland, a broad experience and this with his friendly nature and an ability to get people to work with him, will ensure the success which his many friends in THQ and the Regions wish him.

M.P.G.



**M. M. Faktor, B.Sc., Ph.D.**

Dr. Faktor settled in this country after a childhood in wartime Poland with tragic experience of concentration camps. He completed his secondary education, and obtained a B.Sc. Honours degree in chemistry from London University in 1955 whilst helping to support his family by working as an assistant chemist in a precious-metals refinery. The award of a U.K.A.E.A. Junior Fellowship enabled him to work full-time for a Ph.D. degree in chemistry, which was followed

by one year's further university research as a U.K.A.E.A. Post-doctoral Fellow.

Dr. Faktor joined the Post Office in 1958 as a Temporary Senior Scientific Officer in what was then the Research Branch of the Engineering Department; he was established in 1960 and promoted to Principal Scientific Officer in 1963. Whilst with the Post Office, Dr. Faktor has worked on telecommunications materials, specializing in the thermodynamics and chemical kinetics of the processes which control the growth of highly perfect crystals for semiconductor devices. He has put forward many important new ideas, he has elaborated and exploited them with full professionalism, and he has achieved recognition of his efforts well beyond Dollis Hill.

Dr. Faktor is very happily married, and has two delightful children. His recent special merit promotion to Senior Principal Scientific Officer has been sincerely welcomed by all those who have had the good fortune to be associated with him.

J.I.C.

## Post-Graduate Awards 1970

Each year the Post Office makes a number of post-graduate awards to selected staff. The awards are tenable at universities which have facilities for research or advanced studies in subjects relevant to Post Office problems and activities. These awards cover not only telecommunications science and engineering but also such areas as computers, management, industrial and business administration, marketing, etc. where post-graduate work would be of direct benefit to the Post Office. In appropriate cases the awards enable the holders to qualify for M.Sc. or Ph.D. degrees, but the primary objective is to further research and develop expertise of special value to the Post Office. Awards made this year are listed below.

Mr. I. D. C. Park, Executive Engineer, Telecommunications Headquarters, Research Department, has been awarded a one-year M.Sc. Course in Computing Science at the University of Essex.

Mr. T. J. Eyre, Senior Telecommunications Superintendent, Telecommunications Headquarters, Management Services Department, has been awarded a one-year M.Sc. Course in Operational Research and Management Studies at Imperial College.

Mr. J. L. Stevenson, Scientific Officer, Telecommunications Headquarters, Research Department, has been awarded a two-year M.Phil. Course in Material Sciences—Electro-optics at Imperial College.

Mr. C. B. C. Johnson, Executive Engineer, Technical Support Unit, has been awarded a one-year M.Sc. Course in Computer Science at Edinburgh University.

Mr. C. Johnston, Senior Executive Engineer, Telecommunications Headquarters, Purchasing and Supply Department, has been awarded a one-year M.Sc. Course in Quality and Reliability Engineering at Birmingham University.

Mr. D. Knowles, Executive Engineer, North West Telecommunications Region Headquarters, has been awarded a two-year M.Sc. Course in Management Sciences at Manchester University Institute of Science and Technology.

Mr. F. J. Redmill, Executive Engineer, Post Office Data Processing Service, has been awarded a one-year M.Sc. Course in Electronic Computation at Manchester University Institute of Science and Technology.

Mr. J. M. Read, Executive Engineer, Telecommunications Headquarters, Telecommunications Development Department, has been awarded a one-year M.Sc. Course in Administrative Sciences—Industrial Engineering and Operational Research Techniques at City University.

Mr. F. C. P. Wood, Executive Engineer, London Telecom-

munications Region Headquarters, has been awarded a one-year Course for Diploma in Management Studies at Glasgow University.

The following Officers from Telecommunications Headquarters have all been awarded a one-year M.Sc. Course in Telecommunications Systems at the University of Essex:

Mr. P. N. Branch, Assistant Executive Engineer, Research Department.

Mr. B. A. Fenn, Executive Engineer, Network Planning Department.

Mr. E. B. Holloway, Executive Engineer, Research Department.

Mr. P. Trudgett, Assistant Executive Engineer, Research Department.

Mr. I. D. T. Vallance, Assistant Postal Controller I, Postal Mechanization Department has been awarded a two-year M.Sc. Program in Business Studies at the London Business School.

Mr. B. C. Davies, Assistant Executive Engineer, Postal Mechanization Department, has been awarded a one-year M.Sc. Course in Production at Brunel University.

Mr. A. Corwood, Assistant Postal Controller II, North West Postal Region, has been awarded a one-year M.A. Course in Business Analysis at the University of Lancaster.

### **Supplement**

Students studying for City and Guilds of London Institute examinations in telecommunications are reminded that the Supplement to the *Journal* includes model answers to examination questions set in all the subjects of the Telecommunication Technicians' Course. Back numbers of the *Journal* are available in limited quantities only, and students are urged to place a regular order to ensure that they keep informed of current developments in telecommunications and receive all copies of the Supplement.

### **Syllabuses and Copies of Question Papers for the Telecommunication Technicians' Course**

The syllabuses and copies of question papers set for examinations of the Telecommunication Technicians' Course of the City and Guilds of London Institute are not sold by *The Post Office Electrical Engineers' Journal*. They should be purchased from the Department of Technology, City and Guilds of London Institute, 76 Portland Place, London, W1N 4AA.

### **Publication of Correspondence**

The Board of Editors would like to publish correspondence on engineering or technical aspects of articles published in the *Journal*.

Letters of sufficient interest will be published under "Notes and Comments". Correspondents should note that, as it is necessary to send copy to the printer well before publication date, it will only be possible to consider letters for publication in the April issue if they are received before 15 February 1971.

Letters intended for publication should be sent to the Managing Editor, *P.O.E.E. Journal*, Room 506, Lutyens House, London, EC2.

### **Notes for Authors**

Authors are reminded that some notes are available to help them prepare the manuscripts of the *Journal* articles in a way that will assist in securing uniformity of presentation, simplify the work of the *Journal's* printer and draughtsmen, and help ensure that authors' wishes are easily interpreted. Any author preparing an article for the *Journal* who is not already in possession of the notes is asked to write to the Managing Editor to obtain a copy.

It is emphasized that all contributions to the *Journal*, including those for Regional Notes and Associate Section Notes, must be typed, with double spacing between lines, on one side only of each sheet of paper.

Each circuit diagram or sketch should be drawn on a separate sheet of paper; neat sketches are all that are required. Photographs should be clear and sharply focused. Prints should preferably be glossy and should be unmounted, any notes or captions being written on a separate sheet of paper. Negatives or plates are not needed and should not be supplied.

### **Model Answer Books**

Books of model answers to certain of the City and Guilds of London Institute examinations in telecommunications are published by the Board of Editors. Details of the books available are always given at the end of the Supplement to the *Journal*. The Board of Editors has reduced the price of Line Plant Practice A to 7/6 (8/- post paid).

The Telecommunications Principles Answer Book is out of print at the moment but a revised issue is in preparation and should be available by April 1971.

### **Articles on Current Topics**

The Board of Editors would like to publish more short articles dealing with topical subjects. Authors who have contributions of this nature are invited to contact the Managing Editor.



problem was to find a sufficient number of small builders who would ensure realistic completion dates at competitive tender prices.

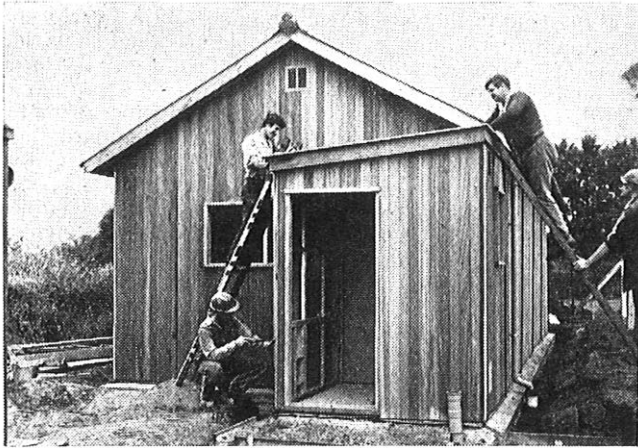

Erection of Silverton S.A.X.

At this point serious consideration was given to the erection of a timber building (Type B1) using Post Office labour to accommodate Silverton S.A.X.

Under the overall direction of the external planning group who provided the necessary co-ordination, the drawing office provided site levels and a comprehensive bill of quantities, the planning group dealt with builders merchants and the external works group provided the labour using a general-purpose working party of four men. The men employed on the job had no experience as builders and no special instructions on building procedures were given.

All site clearance, laying of concrete raft, formation of lead-in ducts, erection of building (sectional) and full toilet facilities, including the provision of a septic tank, was carried out by the working party using mechanical aids normally available from the Exeter telecommunication engineering centre.

Although final accounts have yet to be prepared, it is expected that a substantial saving in costs will result.

However, the important factor is the saving of 12 weeks on completion date obtained by avoiding the tendering procedure, which normally takes eight weeks and by reducing the construction period from 12 weeks to eight weeks.

F. R. STANDEN

## Associate Section Notes

### Oxford Centre

When this item appears in print, the Oxford Section will be halfway through its winter program. Members and guests will have heard lectures on archaeology and cryogenics and sampled various wines at an evening of wine tasting given by a local distributor.

In January, the section will be asking their Telephone Manager pertinent questions to ascertain his function in the area. For February, the study of genetics is promised.

Landline quizzes are becoming increasingly popular and this year five sections in the Eastern Telecommunication Region will be competing in a knock-out series.

D. COTTERILL

### Middlesbrough Centre

The following program has been arranged for the coming season. Meetings will be held in the Cleveland Scientific Institute.

- 29 September: "Running an Area", by Mr. P. Harrison, Telephone Manager, Middlesbrough.
- 13 October: "Satellite Communication", Regional Lecture at York.
- 20 October: Visit to Ferrograph Limited.
- 17 November: Talk and film, "The North Yorkshire Railway".
- 15 December: Visit to Wilton, Imperial Chemical Industries,
- 19 January: "The Hadrian tunnel", by Mr. G. Rowell. Newcastle area.
- 8 February: Film show.
- 9 March: "Appraisements and promotions", by Mr. E. A. Scholey, Regional Engineer, North Eastern Telecommunication Region.
- 9 April: Visit to Amsterdam.
- 22 April: Film show and annual general meeting.

K. WHALLEY

### Norwich Centre

After a period of inactivity, the centre has arranged a varied and interesting program of lectures and visits for the current session which deserves enthusiastic support.

Events for 1971 are lectures on pulse-code modulation and current developments in high-quality sound reproduction, a visit to the North-Sea gas terminal at Bacton and finally the annual general meeting on 28 April.

Good attendances will encourage the committee to continue the good work and produce a further popular program for next session.

S. H. SHEPPARD

### Salisbury Centre

A recent visit to the centre by Mr. G. Bennett, of Telecommunications Headquarters when he delivered an absorbing lecture on pulse-code modulation, had an interesting sequel; the branch organized a weekend visit to the Bonne Nouvelle telephone exchange in Paris, to explore the mysteries of Pentaconta crossbar.

The trip was more successful socially than educationally, and in order to placate suspicious wives, a second excursion to Paris was organized for the autumn to include ladies. One day will be spent visiting the champagne cellars in Reims.

Other activities have included two visits to Bedwas colliery and one to International Business Machines Computers at Hursley, Hampshire. On the lighter side, the committee organized a barbecue and treasure hunt in the New Forest, which, despite the weather, was very well attended.

R. HAWKINS

### Southampton Centre

The Committee for 1970/71 is as follows:

*Chairman:* Mr. R. G. Genge; *Vice-Chairman:* Mr. A. Hutchings; *Secretary:* Mr. M. S. Short; *Treasurer:* Mr. E. J. Green; *Assistant Secretary:* Mr. B. Roberts; *Librarian:* Mr. K. Hammerton; *Committee:* Messrs. M. S. Blake, G. A. Holyoake, D. G. Rolfe, and D. A. Stephenson.

We have started the session by having a demonstration of the driving skills taught at the Devizes training school for patrol car drivers. The members who attended that day were very impressed, as were our colleagues from Bournemouth who visited the school recently, with the expertise which can be added to the daily drive to and from work. Did you know that

the speed limit for a van is still 40 miles per hour, and that a driver is not covered by insurance when exceeding any speed limit?

At a lecture in September, Sergeant Gledhill of the Southampton crime-prevention squad gave us some very sound advice about security at home. He also talked about crime prevention in the larger establishments. By demonstrating models of door and window locks, chains, spy holes, etc., he showed us how a householder can make entering and the thought of entering more difficult for the amateur criminal. Advice from the police is free, but putting their proposals into practice may seem expensive at first sight.

We also visited the Atomic Energy Research Establishment at Harwell on 17 October, the Concorde on 30 November, and the Ordnance Survey Office on 8 December.

R. G. GENGE

### Dundee Centre

At the annual general meeting in April the following office bearers and committee were elected:

*Chairman:* Mr. R. L. Topping; *Vice-Chairman:* Mr. R. C. Smith; *Secretary:* Mr. R. T. Lumsden; *Assistant Secretary:* Mr. A. W. Smart; *Treasurer:* Mr. D. L. Miller; *Committee:* Messrs. W. Bell, A. Dowie, W. Hennessey, J. M. Low, G. Stephen, A. Vaughan, M. Williamson.

The program for the season 1970/71 we hope will be suitable to everyone's taste and is

- 15 October: Visit to a new fire station.
- 10 November: Faraday Lecture, Edinburgh.
- 17 November: "Data Services", by Mr. R. Burns of the Telecommunication Headquarters, Scotland.
- 16 December: Visit to Scottish Occupational Health Laboratory Service, Dundee.
- 13 January: Film on continental camping.
- 16 February: "Computerization and Decimalization in the Clerical Division", by Mr. J. A. Taylor (Area Accountant).
- 9 March: "New Apparatus", by Mr. R. M. Burns and Mr. J. M. Low of Dundee.
- 9 April: Visit to British Petroleum Refinery, Grange-mouth.
- 20 April: Annual general meeting.

We hope our members appreciate the effort put in by the committee to arrange such a program and encourage them by supporting it throughout the session.

R. T. LUMSDEN

### Exeter Centre

At the time of going to press, the summer program will be behind us and the winter program well under way. As mentioned in the last quarter's notes, the first summer excursion was to W. D. and H. O. Wills' factories at Bristol where we were able to visit both the cigar and cigarette factories on the same day.

The former was immensely interesting, in that it was possible to see the processing of the tobacco leaves through all the stages to the finished cigar. The afternoon visit to the cigarette factory, though similar, was mainly a demonstration of mass production techniques capable of turning out filter-tip cigarettes by the thousand, even during the short time we were on the premises. The packaging department also gave us an

insight into the vast amount of thought that goes into such a commonplace article.

On our return journey, we were able to stop off at the Taunton telephone museum. The curator, Mr. P. Povey, was on hand to show us around and many of us were of the opinion that any future calls here would necessitate a drastic revision of our schedule to allow more time to be spent examining the interesting exhibits.

In contrast to our usual round trips of 200 miles or more, we were very fortunate to be invited over the Standard Telephones and Cables valve and capacitor factory at Paignton in June. Here we saw easily recognizable components being manufactured by the latest techniques with almost 100 per cent automation. Our heartiest thanks to Dr. Roberts and his staff for making our evening so enjoyable.

Our September trip was to the far west, namely Camborne. It was a three part visit embracing the Maxam Works, Camborne mining museum, and Holman Brothers engineering works. To do justice to the above one would need at least a day at each, but what we were shown only whetted our appetite, and perhaps we shall be lucky enough to receive a return invitation at some future date.

The dates of the winter program were not available at the time of going to press but all members should have received their Centre cards by now.

J. J. F. ANNING

### Glasgow Centre

At our annual general meeting held in May 1970 the following appointments were made:

*President:* Mr. J. Sommerville; *Chairman:* Mr. J. McCallum; *Vice-Chairman:* Mr. W. Fotheringham; *Secretary:* Mr. R. I. Tomlinson; *Assistant Secretary:* Mr. R. Stevenson; *Treasurer:* Mr. K. Gordon; *Librarian:* Mr. N. Cochrane; *Committee:* Messrs. W. Bolton, J. Moore, H. McNamarra, J. McAuley, N. Barr, N. V. Potts, F. Hamilton, J. Hatfield, P. McPride, C. Faith, J. S. Mitchell, M. Love, J. Roney and J. Duffy.

The following is a copy of our syllabus for the 1970/71 session meetings:

- 15 October: Mr. Revell (Director, Telecommunications Headquarters, Scotland), "L.T.P. and L.S.D." (Long Term Planning and £ s. d.).
- 19 November: Visit to Grid Control Centre, Kirkintilloch.
- 17 December: Visit to National Engineering Laboratories, East Kilbride.
- 14 January: Film show.
- 18 February: Mr. Wilson, Philips Electrical, "Tape recorders and unit audio".
- 18 March: Mr. Jack House, "Old Glasgow".
- 15 April: Dr. Bray (Principal, Technical Training College, Stone), "Submarine cables."
- 7 May: Annual general meeting.

May we take this opportunity of extending an invitation to members from other I.P.O.E.E.(A) centres who may be in Glasgow on any of the above evenings and who may care to come along. All our meetings commence at 7.30 p.m. in the Conference Room, 4th Floor, Telephone House, Pitt Street, Glasgow.

The Glasgow Centre would like to wish every success to the new associate section being formed in Stirling and offer support from their membership to attend, if possible, some of the Stirling Meetings.

R. I. TOMLINSON

# Institution of Post Office Electrical Engineers

## Annual Awards for Associate Papers, Session 1969-70

The Judging Committee having adjudicated on the papers submitted by the Local Centre Committees, prizes and Institution Certificates have been awarded to the following in respect of the papers named.

First prize of £7 7s.:

R. Milton, Technical Officer, Brighton Centre. "Some aspects of pulse code modulation."

Prizes of £4 4s.:

H. C. Hawkins, Technical Officer, Stoke-on-Trent Centre.

"Some aspects of Local Radio, Past, Present and Future."

R. Mathewson, Technical Officer, Aberdeen Centre. "Automatic Busyng of Trunk Circuits."

A. W. Smart, Technical Officer, Dundee Centre. "A Look at a PABX No. 6."

The Council of the Institution is indebted to Messrs. A. J. Barker, R. Kearsley-Brown and A. H. Watkins for kindly undertaking the adjudication of the papers submitted for consideration.

## Local Centre Secretaries

The following is a list of Local Centre Secretaries and to whom inquiries about the Institution may be addressed. It would be particularly useful if members would notify any change in their addresses to the appropriate Secretary.

Centre	Local Secretary	Address
London	Mr. J. S. Gilroy	Telecommunications Headquarters, TD2.4 Procter House, 100-110 High Holborn, London WC1V 6LD
Stone—Stoke	Mr. R. V. Walters	Technical Training College, Stone, Staffs ST15 ONQ.
Eastern	Mr. R. A. Spanner	Planning Division (Plg D 3.2.2), Eastern Telecommunications Region, St. Peters House, St. Peters Street, Colchester, Essex.
South Eastern	Mr. J. T. Crocker	Planning Division (PL/L1/2), South Eastern Telecommunications Region, Grenville House, 52 Churchill Square, Brighton BN1 2ER.
North Eastern	Mr. H. Teale	Planning Division (PLE 212), North Eastern Telecommunications Region, 36/37 Park Row, Leeds LS1 1EA.
Northern	Mr. B. O. Slater	Telephone Manager's Office, Telephone House, Carlisle Square, Newcastle-on-Tyne NE1 1BA.
Birmingham	Mr. D. M. Clement	Planning Division (PL/CPA 1), Midlands Telecommunications Region, 95 Newhall Street, Birmingham 3.
East Midland	Mr. D. W. Sharman	Post Office Telephones, Essoldo House, 87 Granby Street, Leicester LE1 6FD.
North Western (Manchester and Liverpool)	Mr. H. R. H. Clough	Planning Division, North Western Telecommunications Region, Bridgewater House, 60 Whitworth Street, Manchester M60 1DP.
North Western (Preston)	Mr. J. W. Allison	Post Office Telephones, Clifton Road Depot, Marton, Blackpool FY4 4QD.
Wales and Border Counties	Mr. J. R. Jones	Planning and Works Division, Telecommunications Headquarters, Wales and the Marches, 2 Plymouth Street, Cardiff CF1 4XZ.
Scotland East	Mr. I. M. Claireaux	Planning Division (PL 241), Telecommunications Headquarters, Scotland, Canning House, 13 Canning Street, Edinburgh EH3 8TH.
Scotland West	Mr. A. M. Caldwell	Telephone Manager's Office (ELD22), Marland House, 40 George Street, Glasgow C.1.
South Western	Mr. C. W. Read	Planning Division (PL1.5.1), South Western Telecommunications Region, 13 Woodland Road, Bristol BS8 0TT.
Northern Ireland	Mr. W. J. Gawley	Telephone Manager's Office, Churchill House, Victoria Square, Belfast BT1 4BA.

# Press Notices

## Third Aerial for Goonhilly

The Post Office has placed an order worth about £2¼M with Marconi to build a third aerial for the satellite earth-station at Goonhilly Downs, Cornwall.

As second largest partner in INTELSAT, the International Telecommunications Satellite Consortium, Britain is already in the major league of satellite users. With three large aeriels, Goonhilly will be one of the largest and busiest commercial earth-stations in the world. The third aerial system—Goonhilly 3—is expected to go into service early in 1972, working with the next generation of satellites—Intelsat IV, first of which is to be launched into position over the Atlantic next year.

The Post Office has played a leading part in the development of international satellite communication. Its first aerial system, Goonhilly 1, was put into service in 1962 and provided the basic pattern for most of the world's earth stations. It was used in experimental transmissions through the Telstar and Relay satellites and went into full commercial operation in 1965, working to the Intelsat I satellite (Early Bird). Since then it has been extensively modified and it now provides Britain with satellite service to the East as far as Australia through an Intelsat III satellite stationed over the Indian Ocean. In this area, Britain far outstrips all other countries as the major satellite user.

Goonhilly 2—built by Marconi—came into service early last year. It links Britain with the Americas, the Middle East, and North Africa through another Intelsat III satellite stationed over the Atlantic.

The number of satellite circuits used by the U.K. rose from 30 at the end of 1965 to 276 last December (when the world total was 1,414 circuits) and is expected to reach 450 circuits by the end of this year.

*Future.* Goonhilly 3 is designed to work with Intelsat IV satellites, which will have about four times the capacity of Intelsat III. The first Intelsat IV satellite, to be launched into synchronous orbit over the Atlantic next year, will be able to carry up to 5,000 two-way telephone calls or the equivalent in television transmissions.

Even without the development of Intelsat IV, a third aerial would have been needed at Goonhilly to cater for the growth of telecommunication traffic across the Atlantic. Demand for telephone and telegraph services and other facilities—including transmission of computer data—is expanding so rapidly that it would exhaust the capacity of both Atlantic Intelsat III satellites by the time that Goonhilly 3 comes into operation.

The Cassegrain dish of the Goonhilly 3 aerial is 97 ft in diameter—even larger than the other Goonhilly aeriels. The reflector panels will be made of aluminium instead of stainless steel. It will be mounted on a reinforced concrete tower which will house the bulk of the radio equipment. The automatic tracking equipment is entirely electronic, and operation of the new terminal will be controlled from an extension of the console in the station's main building from which Goonhilly 1 and Goonhilly 2 are controlled.

## One-in-Ten Reserve Scheme for Trunk System Circuits

To give an even more reliable long-distance telephone service, the Post Office is organizing a 10 per cent reserve of channels in the trunk cable system.

This reserve will provide, in effect, a stand-by network over which calls can be re-routed immediately there is a breakdown caused, for example, by road works, floods, subsidence or simple electrical fault.

By 1975 this one-in-ten standby-to-working ratio will provide reserve cover for the major part of Britain's main-line trunk telephone network. Installation of the first coaxial links in the network started last year.

This reserve network, which is being set up in the Post Office's massive telecommunications expansion program, will give customers more reliable trunk service in several ways. Principally, it will give more alternative routes for calls. Should a fault develop in a coaxial system, circuits affected will be switched to spares in the same cable or, in the event of a

complete cable failure, the calls will be transferred to another cable or to microwave radio-relay links.

Speedier investigation of faults over the stand-by network will also mean that traffic circuits affected will be out of action for a shorter time. In addition, the reserve will permit more maintenance to be carried out during normal working hours and will allow working transmission systems to be closed down for modification and modernization.

Stand-by protection links are already providing improved service for customers. For example, some London-Manchester circuits were recently in use for 27 per cent of the time over a 14-week period. They were used in roughly equal proportions for improvement work, for maintenance, and for by-passing faults.

Switching from main line to stand-by circuits will be carried out at repeater stations around the country where necessary, but it will be controlled from a co-ordination centre in London.

For maintenance purposes, the switching will be made at high speed to avoid noticeable interruptions in calls.

Basic units chosen at this stage for switching are 4 MHz (960 circuits) and 12 MHz (2,700 circuits) line sections.

## Telecommunications or Personal Encounter?

Radical changes in the way people conduct their business affairs and private matters, in their travel habits, and in their choice of places for living and working, could result from future developments in communications—particularly with a growing use of visual services.

To learn as much as possible about the relative effectiveness of present and future means of sound and visual telecommunications between people—compared with communication by personal encounter—the Post Office and the Civil Service Department are jointly sponsoring a three-year research project at University College, London, at a total cost of £70,000.

For the first time, laboratory research is attempting to compare in a wide ranging and systematic way the relative effectiveness of future telecommunications media. The work has implications for the location of commercial and residential development, business organization and people's travel needs. The research is part of a wide range of communication problems involving human factors being studied by the Post Office, with its strong commercial and technological interest and its duty to provide the nation's telecommunications. It is also of direct concern to the Civil Service Department, with its responsibilities for efficient governmental administration, which depends so much on effective communications.

The research team will include specialists in urban planning, experimental social psychology, operational research, and electronic and telecommunications engineering. The six-man team will be led by Mr. Alex Reid, a 29-year old architect and former Fleet Air Arm Pilot, who has already carried out some studies relating communications with travel between home and workplace. Following a pilot study begun last year, the new project is to be carried out in a communications laboratory at University College, London, and later in a mobile communications laboratory housed in three trailers that will visit selected government and business establishments.

Laboratory studies are appropriate for measuring effectiveness, but there remains the question of acceptability which can scarcely be judged in an artificial environment. For this reason the Civil Service Department has been conducting field trials using, for a start, telephone conference facilities, facsimile document transmitters and pantographs in a widely dispersed government department to determine how extensively people would use such equipment as an alternative to face-to-face meetings.

The researchers are keeping in close touch with other relevant work being carried out in this country and abroad.

Visual telecommunication in this country has so far been confined to specialist fields, such as public television broadcasting, and closed-circuit television for hospitals and schools. But two-way visual telecommunications may have much greater potential in the future. The Post Office has started trials with a telephone that will enable the users to see each other, and it recently announced plans to introduce to a



number of major cities next year a "conference by television" service to be known as Confravision. This new research will take development possibilities on from there.

### **Human Factors in Telecommunications—Experts from 14 Countries Investigate the Problems**

As the worldwide telecommunications network grows ever larger, there is a tendency for the manipulative problems facing the ordinary user of the system to become ever more complex.

In the early days of the telephone, when the customer had access to only a few thousand other subscribers, the problem of connecting calls was not very difficult. The number of other telephone subscribers with whom he can now be connected has grown to hundreds of millions, and the process of connecting them has inevitably become more complicated. And in addition to merely talking over a circuit, a customer can send data and printed information. Before long he may have the option of a vision link as well.

Faced with these developments telecommunication engineers all over the world are seeking to discover how the system's operation can be kept simple enough for the ordinary user to be able to cope with it.

Experts in human-factors engineering met in London to pool their knowledge and experience in dealing with the situation. Nearly 100 delegates from 14 countries attended the International Symposium on Human Factors in Telecommunications at the Institution of Electrical Engineers, Savoy Place.

This was the fifth and largest symposium of its kind. Earlier symposia have been held in Cambridge, Copenhagen, The Hague and Bad Wiessee in Bavaria. This year's symposium is sponsored by the British Post Office with the support of the Telecommunication Engineering and Manufacturing Association, and the Medical Research Council's Applied Psychology Unit.

About 30 papers were given during the symposium's five days, describing experimental and field studies that have been made by human-factors engineers and psychologists of various aspects of telephone users' behaviour when confronted with typical situations.

Papers were contributed by Britain, the United States of America, Western Germany, the Netherlands, and Sweden. Delegates also attended from Finland, Denmark, Canada, Australia, Norway, France, Belgium, Italy and Japan.

The symposium was opened by Mr. W. J. Bray, Director of Research in the British Post Office, and he presented the first paper surveying British work in human-factors research.

Dr. Ivan Brown of the Medical Research Council's Applied Psychology Unit at Cambridge discussed the role of the applied psychologist in communications research, and Dr. John Karlin of the Bell Telephone Laboratories surveyed the American field. Other sessions described experimental studies of some particular aspects of telephone-user performance. Papers were concerned with such things as callers' difficulties in dialling, troubles in interpreting signalling tones, conversational difficulties over very long distance connexions and the problems faced in replacing telephone dials with push-button keys.

One session was devoted to visual communications and the part played by "eye-to-eye" contact during normal conversation—and the implications of this in person-to-person telephone conversations when a vision link is also provided.

### **Low-Capacity Digital Radio-Relay System**

With trunk telephone traffic doubling every seven years and data-transmission services growing rapidly, the Post Office is stepping-up the campaign to use its expanding telecommunications system most effectively.

Digital transmission makes intensive use of existing channels, and the Post Office is exploring new ways by which digital signals can be transmitted over its network of cable and radio links.

Latest move in the campaign is an order placed with GEC-AEI to develop the field-trial version of a new radio-relay link to transmit digital signals over the microwave network.

The new super-high-frequency system will be able to use the aerials and feeders of the present analogue systems and will make it easier to provide supervisory channels for them.

Up-to-date solid-state techniques will be used throughout the new equipment, which will be small enough to mount near the aerial where necessary, and will have an output of a few hundred milliwatts.

Lying directly below the 500 MHz-wide spectrum used for the analogue broadband systems of the microwave network, the frequency band of the new digital system will be 75 MHz wide—5,850–5,925 MHz. Where aerials are not available, separate ones will be provided.

The 75 MHz bandwidth will accommodate six bothway narrowband digital channels of which two will serve as auxiliary bearer channels with a capacity of 2.048 Mbit/s. They will provide a fully-protected channel for carrying control, alarm and supervisory signals and engineering speaker circuits for all radio-relay systems working over the same route, enabling the frequency bands carrying the present analogue systems to be used more efficiently.

The other four channels, each of 6.336 Mbit/s capacity, will carry various trunk digital signals—for example, 48 kbit/s for high-speed data transmission and digital program circuits. Details of uses to which these channels will be put in the network, including the ratio of stand-by circuits to working circuits, will be worked out during tests with the field-trial system.

Field trials are scheduled to take place towards the end of 1972 at the conclusion of the development contract and the first production systems are expected to be ordered soon afterwards.

### **60 MHz Coaxial Line System for Trunk Supercables**

To cater for the greatly increased number of trunk calls by the late 1970s—expected to double from the present 8,000 million a year—the Post Office plans to install 18-tube and 8-tube coaxial cables capable of carrying four times as many circuits in each pair of tubes as in any cables so far used in the United Kingdom.

The Post Office announced last month that an 18-tube "supercable" with a total capacity of 97,200 circuits is planned to link London, Birmingham and Manchester by the middle 1970s. A number of 8-tube coaxial cables are also planned. Each pair of tubes in these cables will be equipped with 60 MHz frequency-division-multiplex line systems to enable it to carry 10,800 telephone circuits.

Following feasibility studies, the Post Office has placed a contract with the Telephone Manufacturing Company Ltd to develop equipment for a 60 MHz line system and provide apparatus for a field trial on an experimental route near Marlborough during 1973.

The Post Office expects that experience gained in the field trial will make it possible to start production of systems in time for the first route between London and Birmingham to be ready for service during 1975.

Amplifiers for the line system will embody the very latest developments in transistor design and linear circuit techniques.

The system will employ a method of compensation for temperature changes which has not previously been used in the U.K. This enables the number of components in the buried amplifiers to be reduced significantly.

These amplifiers will be installed at intervals of 1.5 kilometres. Any improvement in their reliability will contribute significantly to overall system reliability—of great importance because in this system a fault, resulting in the loss of 10,800 circuits, would cause inconvenience to the public and financial loss to the Post Office.

Other moves to ensure that the new system gives maximum reliability during its expected service lifetime of 25 years include burying the cable at 1.3 metres—twice the usual depth—and providing automatic change-over to a spare system in the event of fault.

### **Cardigan Telephonists' Key Job for Concorde Supersonic Test**

Observation points along the Concorde supersonic test flight path have been provided with special telephone links to the Ministry of Technology Royal Aircraft Establishment centre at Aberporth, Cardigan, South Wales.

For the tests, Post Office telephone operators have a key job at the heart of the test communications network in Cardigan telephone exchange.

Their job is to connect calls swiftly at specified times for observers to make reports to Aberporth from more than 30 strategic points in Western Scotland, Northern Ireland, the Isle of Man, Wales, North-West England and Cornwall.

Before, during and after each test flight the telephonists at Cardigan connect calls to the observation posts from Aberporth, working to a detailed plan.

Post Office engineering staff at Cardigan are on stand-by throughout the test program.

At the satellite communications earth station at Goonhilly, Cornwall, Post Office engineers, staff from the Royal Aircraft Establishment, and a firm of consulting engineers are co-operating to measure any effect of sonic shock waves upon the giant dish aerials.

### **New Peterborough Sorting Office opened**

A massive new £1.5M fully mechanized parcels sorting office at Peterborough, which is planned to handle over half-a-million parcels a week, was opened by Mr. A. W. C. Ryland, Post Office Chairman and Chief Executive, accompanied by Mr. Geoffrey Vieler, Managing Director, Posts and Giro.

The new sorting complex is the first Turnkey office ordered by the Post Office, with the contractor (John Laing Construction, Ltd.) building and equipping the office ready for use.

The new sorting office is also the third of a series of 32 mechanized centres planned as "zone hubs" for the parcel network that will cover the whole of the United Kingdom. Each will be linked by direct and speedy rail or road transport, with metal containers replacing mail bags.

Each office will collect parcels posted in its own zone, sort them for delivery in the 32 zones—including its own—and send off those for the other 31 in containers. Right from the start, Peterborough will be the centre for a huge area which will include Lincolnshire, Cambridgeshire, Norfolk, Suffolk, Huntingdonshire and Essex.

Under the national plan, parcel post is to be completely reorganized. It will cost the Post Office £50M in buildings, plant and equipment and will effect a saving in operating costs of about £4M a year.

The Post Office handles 200-250 million parcels a year—all of varying sizes and weights, demanding highly specialized equipment to deal with them swiftly and safely. Parcels are not conveniently uniform, like milk bottles or house bricks, and finding the right mechanical aids to swifter and more efficient handling presents special problems for the Post Office.

About 250,000 parcels will be handled by the Peterborough office each week. This figure is expected to double when the office becomes fully operational as a Parcels Concentration Office in a year or two's time.

The Peterborough office was planned, built and equipped in only 19 months, compared with the usual time of five to six years.

Not only has this method enabled the Post Office to gain the economic benefit of the parcels office much earlier, it has also helped it to keep a tight control on all aspects of the job during day-to-day construction and planning.

The new office has been designed to meet the needs not only of the Post Office, but also those of British Rail, whose facilities were closely incorporated from the earliest planning stage, and of a large, local mail-order firm, Freemans Ltd., who have a direct connexion by continuous loading belt right from their warehouse on the other side of the main line between Kings Cross and the North-East.

Highlight of the mechanization is the primary sorting method. A sorter reads the address on the parcel, selects a key for the destination on a small keyboard, and releases the parcel along the moving belt, which is tilted at a 30-degree angle. According to the key selected, the correct destination door opens automatically, as the parcel reaches it. Eight sorting machines can each handle up to 1,500 parcels an hour. Other parcel sorting offices already constructed, as zone hubs are at Reading and Nottingham. Soon to be opened is one at Birmingham.

The Turnkey scheme has worked out so well that orders for a further two mechanized sorting offices—at Cardiff and Southampton—have been put out to tender.

### **Britons will be Dialling "Down Under" in a few years' time**

British telephone customers will be able to dial their own calls to the other side of the world within a few years.

Following the introduction of customer dialling between London and New York in March of this year, the Post Office plans to introduce in the next two or three years dialled calls to Canada, to the rest of the United States and on to New Zealand and Australia.

Already 95 per cent of all telex calls from this country are dialled by the customer.

"This is the telephone and telex pattern for the future—Commonwealth and other international services of great flexibility and reliability with, I trust, an ever-improving speed of connection, especially for the customer who dials his own calls," said Mr. James Hodgson, Director of External Telecommunications, addressing the Quinquennial Conference of the Commonwealth Press Union at Gleneagles.

International business in this country was growing at over 20 per cent a year in telephone calls, telex calls and leasing of private lines, said Mr. Hodgson. The international telegram service was also growing, though more slowly, and it represented, in absolute terms, a huge volume of communication.

"Between the countries of the Commonwealth the rates of growth are even higher—the inter-continental telephone and telex business of the Post Office grew by over 25 per cent last year and all the evidence suggests that growth on this scale will continue over the next few years at least," he said.

Growth was stimulated not only by the communications appetite of businessmen, including Pressmen, and social users of telephone services, but also by the improved quality of long-distance links by submarine cables, satellites and modern high-frequency radio systems.

### **Call Opening New Exchange is Answered by Computer**

A new £1¼m trunk telephone exchange, Turret, at Salford, was opened automatically by a telephone call to the Post Office Data Communications stand at the Computer '70 exhibition at Olympia, London. The call was made by the Mayor of Salford, Ald. G. M. Joplin, accompanied by Mr. Edward Fennessy, Managing Director, Telecommunications, of the Post Office.

Alderman Joplin's call was answered automatically by a Trendata terminal on Standard 96/101 at Olympia which flashed to Salford information about Turret. Printed out on a Teletype machine, this was shown to guests at the opening on closed-circuit TV screens.

The Data Communications stand at Olympia was designed to promote the Post Office Datel services both present and future and provide expert advice on data transmission.

A number of on-line demonstrations of Datel services now in use were shown. These included:

- Data Control Equipment (D.C.E.) which enables computers to dial telephone and Telex calls in order to send data;
- A Telex machine demonstrating Datel 100 working through a D.C.E. No. 3 over the public Telex network to the Atkins Computing Services computer centre at Epsom;
- An Olivetti terminal working over the public network using Post Office Modems No. 2 on the Datel 200 service to a computer at Sanaco Ltd., Birmingham;
- A Burroughs terminal using Post Office Modems No. 1 over a private circuit, demonstrating the Datel 600 service working to a Burroughs Ltd. computer in central London at a transmission speed of 1,200 bits per second;
- A second Datel 600 demonstration of a Ticketron terminal working over a Post Office private circuit using Post Office Modems No. 1 to a Seat Reservations Ltd. computer in central London;
- A Marconi-Elliott visual-display unit connected over a private circuit to a University of Essex computer at Colchester, demonstrating the Datel 2400 service.

The main feature of the stand was the recently introduced Datel 48K service.

Two Modular One computers supplied by Computer Technology were working over a Post Office wideband link across the stand and the output was displayed on a large television-type screen. Transmission at a speed of 48,000 bits

per second using Post Office Modems 8 and 9 makes the interconnection of computers an economic proposition.

### Communicating Data

To stimulate the flow of ideas on data communication between its customers and itself, the Post Office has arranged a series of one-day seminars. Represented on the seminars are computer equipment manufacturers, computer bureaux, Government departments and local authorities, universities, and organizations making extensive use of computers and data transmission.

The discussions centre on papers presented by Post Office experts on the current likely future demand for data-communication services, and on transmission methods and control procedures that could help to meet future requirements for data users.

Views and suggestions put forward at the seminars will help the Post Office in planning technical development and market research. The seminars have been planned to help those attending to assess the impact on their systems or equipment of the possible services which could be offered. Each will be attended by about 45 people—numbers have been kept to this level to help promote useful discussions. Chairman for the series is Mr. H. Barker, Director of Network Planning. Papers are being presented by Mr. G. Dale of Telecommunications Marketing Department and by Mr. N. Smith and Mr. K. J. Chapman of Telecommunications Development Department.

Mr. Dale examines the current situation in data communications, the growth in the number of terminals and how the Post Office is shaping its development programme to meet future needs. (Post Office data terminals are doubling in number each year and there are now over 12,000 in operation. By 1973 there could be 50,000 terminals in use in Britain and by 1983 half-a-million.)

Mr. Chapman and Mr. Smith speak on data users' future requirements and the possibility of the Post Office setting up

a data-transmission system using switching techniques separate from the telephone network. Such a system would mean new interfaces and call-control procedures to bring maximum benefit to users, and these aspects will be open to full discussion.

### International Satellite Working Party Meeting in London

A ten-nation conference on making the best use of the world's growing satellite communications opened in London on Monday (19 October).

About a dozen commercial satellites are now in orbit around the earth and more will follow rapidly over the next few years. Putting satellites into geo-stationary orbit must be co-ordinated internationally so that they are positioned to the best advantage, and interference between satellites is avoided.

The international Working Party of the CCIR (International Radio Consultative Committee), to which the study of this problem has been assigned, held its second meeting from 19-23 October under the Chairmanship of Mr. J. K. S. Jowett, a Deputy Director of Engineering of the Post Office. Delegates from Australia, Canada, the Federal German Republic, France, Japan, Poland, Switzerland, the UK, the USA and the USSR met at Lutyens House, one of the headquarters buildings of Britain's telecommunication business.

The Working Party will later report to a Joint Meeting of CCIR Study Groups, in Geneva next February and March, at which extensive technical preparations will be made for the World Administrative Radio Conference of the ITU (International Telecommunications Union).

Meeting in Geneva in June and July 1971, the World Conference will plan revision of the international regulations which govern Space Telecommunications, including the various forms of satellite communication. This planning will form the mould within which these services will be shaped over the coming decade.

### BOARD OF EDITORS

- N. C. C. de JONG, B.Sc.(Eng.), C.Eng., M.I.C.E., F.I.Mech.E., F.I.E.E., Chairman  
E. W. AYERS, B.Sc.(Eng.), C.Eng., F.I.E.E.  
A. J. BARNARD, C.Eng., M.I.E.E.  
D. R. BEARHAM, B.Sc.(Eng.), C.Eng., M.I.E.E.  
S. H. SHEPPARD  
A. C. CROISDALE, M.B.E., B.Sc.(Eng.), C.Eng., M.I.E.E.  
J. MARTIN, B.Sc.(Eng.), C.Eng., M.I.E.E.  
N. J. H. NINIM, M.Sc., B.Eng., Managing Editor  
R. A. SUDELL, Deputy Managing Editor  
P. G. STEELE, M.Sc., B.Sc.(Eng.)  
D. MILLINGTON, C. Eng., M.I.E.E. } Assistant Editors  
T. R. K. RAITT }  
B. FARR, A.B.I., Secretary-Treasurer  
N. G. CRUMP, M.I.T.E., Advertisement Manager

### Copyright

The entire contents of this Journal are covered by general copyright, and special permission is necessary for reprinting long extracts, but editors are welcome to use not more than one-third of any article, provided that credit is given at the beginning or end, thus: "From *The Post Office Electrical Engineers' Journal*."

The Board of Editors is not responsible for the statements made or the opinions expressed in any of the articles in this Journal, unless such statement is made specifically by the Board.

### Subscriptions and Back Numbers

The Journal is published quarterly, in April, July, October and January, at 4s. 3d. per copy: 6s. per copy including post and packing (24s. per year) via inland mail, and 4s. 9d. (3 dollars Canada and U.S.A., per year) via overseas mail. Back numbers will be supplied, if available, price 4s. 9d. (6s. 6d. post paid) per copy.

With the exception of January and October 1966 Journals, copies of the April 1967 and all earlier Journals are no longer available. Orders, by post only, to *The Post Office Electrical Engineers' Journal*, 2-12 Gresham Street, London, E.C.2V 7AG.

Employees of the British Post Office can obtain the Journal through local agents.

### Binding

Readers can have their copies bound at a cost of £1 12s. 6d. plus 4s. 6d. return postage, by sending the complete set of parts, with a remittance to Press Binders Ltd., 4 Iliffe Yard, London, S.E.17.

### Remittances

Remittances should be made payable to "*The P.O.E.E. Journal*" and should be crossed "& Co."

### Advertisements

All correspondence relating to advertisement space reservations, copy, proofs, etc., should be addressed to the Advertisement Manager, *The Post Office Electrical Engineers' Journal*, 2-12 Gresham Street, London, E.C.2.

### Communications

With the exceptions indicated above, all communications should be addressed to the Managing Editor, *The Post Office Electrical Engineers' Journal*, 2-12 Gresham Street, London, E.C.2.

### Model Answer Books

Books of model answers to certain of the City and Guilds of London Institute examinations in telecommunications are published by the Board of Editors. Details of the books available are given at the end of the Supplement to the Journal.

# Our resistors have 50,000 'appy ohms to go to!

50,000 'appy customers we've got. We keep 'em 'appy by delivering the goods on time. Every time.

Take resistors for example. We can supply anything from a  $\frac{1}{4}$  W 10 K Hystab to a double gang 1 M pot with double pole switch - from stock. All the resistors below get the same treatment. And everything else from adhesives to zener diodes.

Order today and they'll be in the post today. How about making your ohm 'appy?

## ***Radiospares***

P.O. Box 427,  
13-17 Epworth Street, London.  
EC2P 2HA Tel: 01-253 7501  
Telex: 262341.

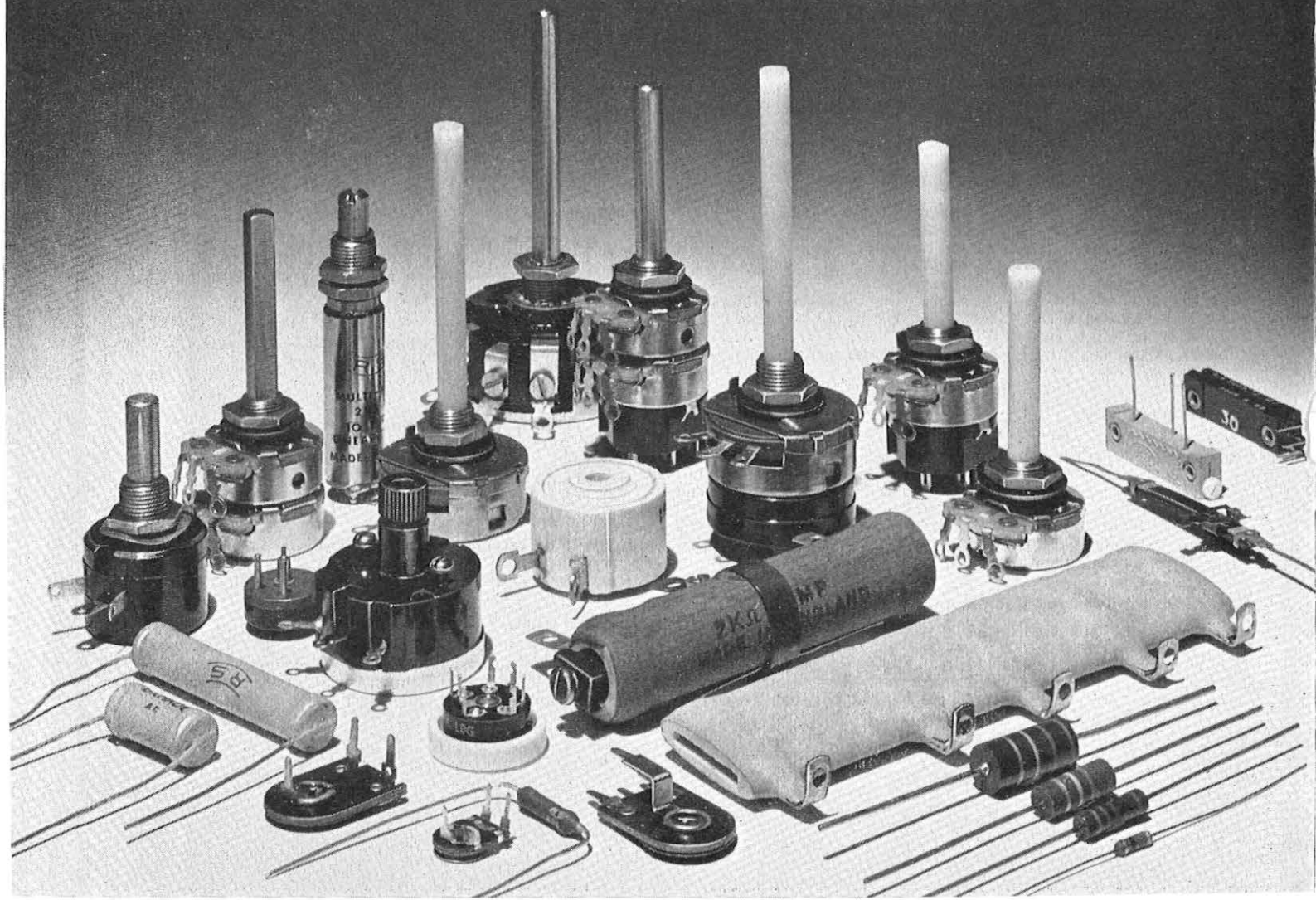

**You've got 6 gossips gossiping,  
5 chatterers chattering, 2 whiners whining,  
1 moaner moaning,  
5 prattlers prattling, 4 jabberers jabbering**

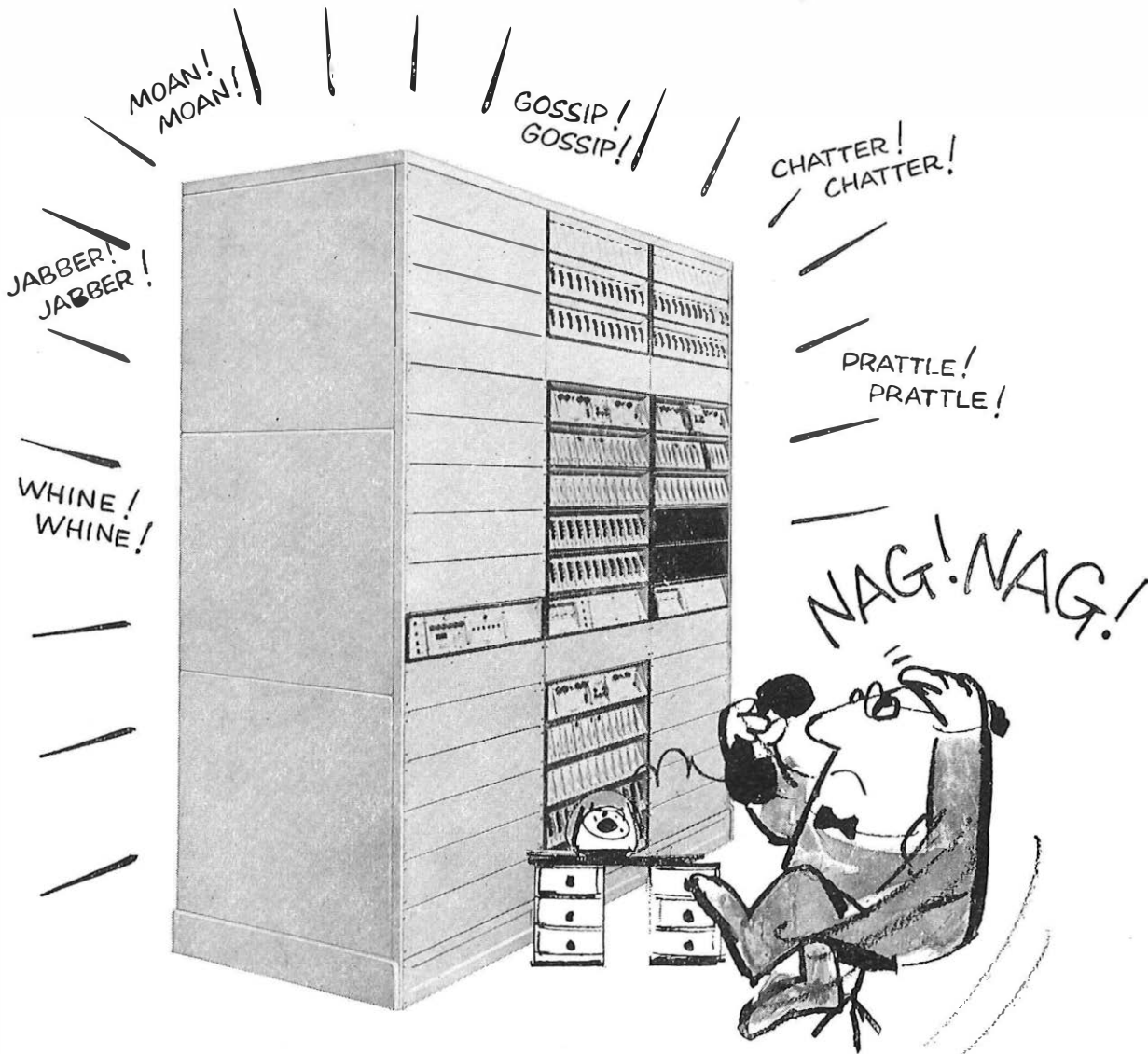

**and you can still call your wife on the same line!**

The Plessey 24 Channel Pulse Code Modulation Equipment provides 24 2-way telephone channels—over two pairs in audio cables. The system has been produced from designs developed to cater for the British Post Office. It is arranged for complete flexibility and allows the use of rackside shelfspace to meet the particular demands of any location.

The system provides additional low loss circuits on existing or new cable pairs, and is of particular use in conditions where induced noise and crosstalk are prevalent. It is possible to use the

equipment on cables where other carrier equipment does not operate satisfactorily. The speech channels have an effective bandwidth of 300—3,400Hz, and each channel is provided with signalling facilities via a wide range of units. Give us a call and find out more about Plessey PCM.



**Plessey Electronics**

Transmission Division,  
Beeston, Nottingham NG9 1LA, England.  
Tel: Nottingham (0602) 254831 Telex 37201

**Type M1117. Shortly to be in service with the Post Office.** Completely new, all solid-state trunk system incorporating a T.W.T. amplifier. Designed for continuous, unattended operation. Capacity: 960 telephone circuits or 405/625 line colour television with sound channel.

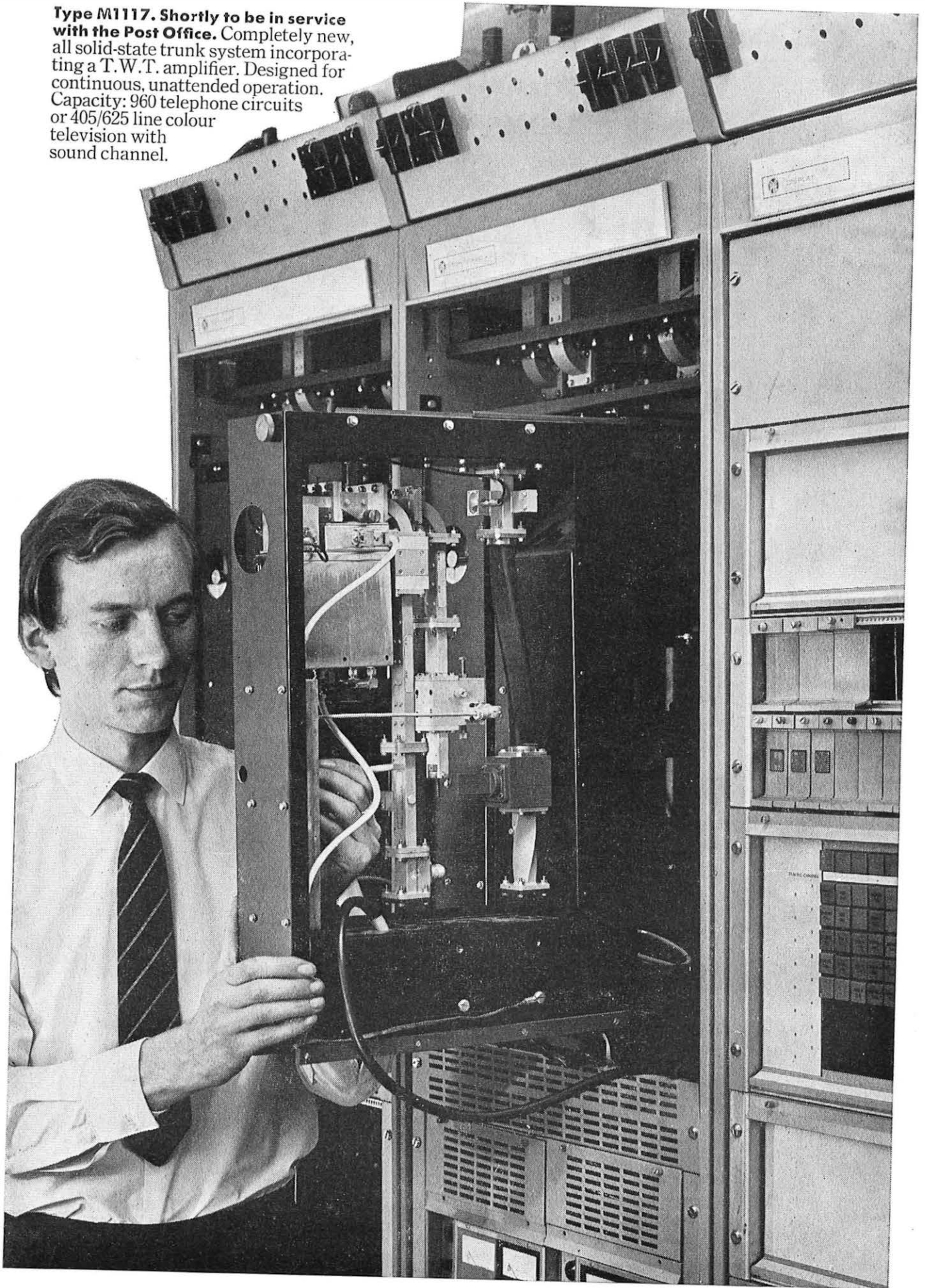

# Contracts for Pye microwave links top £1,000,000

Pye manufacture microwave links as professionally as anything Pye make. Proven, high-performance microwave links, in the 6/7 and 10/13 GHz bands, fully tested and engineered for quick installation, *with delivery on time.*

That's why the orders keep coming in.

Full details from: Pye Telecommunications Ltd.,  
Dept. 55, Newmarket Road, Cambridge CB5 8PD.  
Tel: Cambridge (0223) 61222. Telex: 81166.

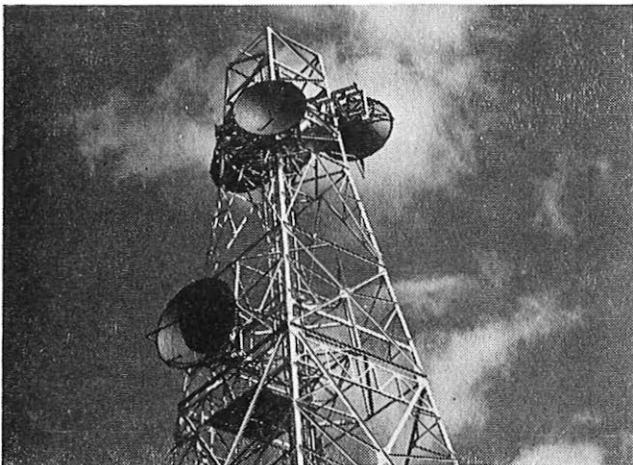

A typical antenna tower installation.

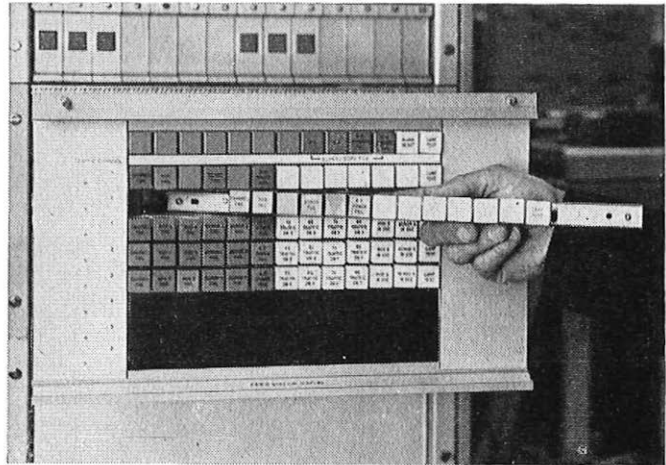

IF58 Switching/Control System. Expanded from 1+1 to 6+2 or 7+1 by plug-in facilities. All integrated circuit logic. Routine auto test facility.

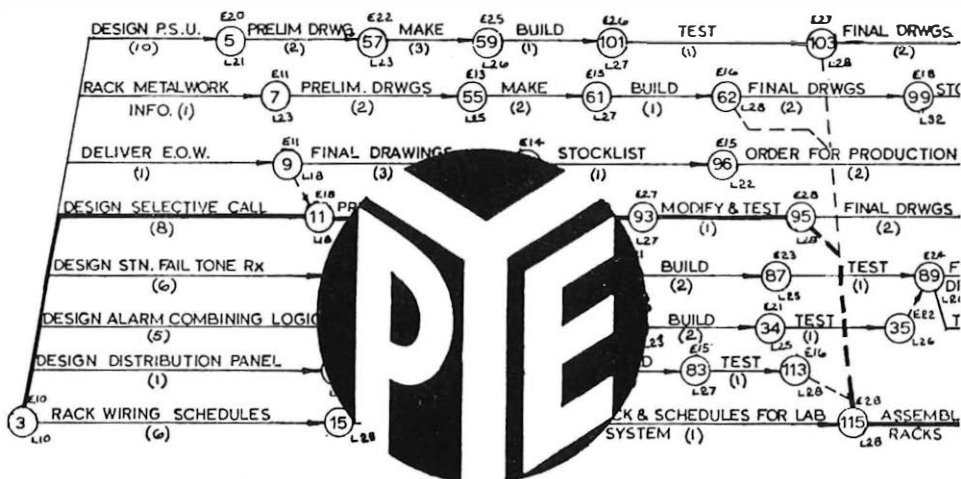

**Rely on Pye-it's professional**

# ALKEN

ALKEN PRECISION ENGINEERS LIMITED

PALACE OF ENGINEERING OLYMPIC WAY  
WEMBLEY MIDDLESEX TEL. 01-902 8381

An open letter to all our PO friends inviting them to use our new and extended workshop facilities for the production of mechanical and electrical telecommunication jointing aids.

We should be very happy to introduce our one-off and short production run manufacturing services to an even wider circle of PO engineers and trust that this letter will serve as our introduction to those with no previous knowledge of the firm: let us help if we can—it's our business.

ALF WESTWOOD,  
*Director*

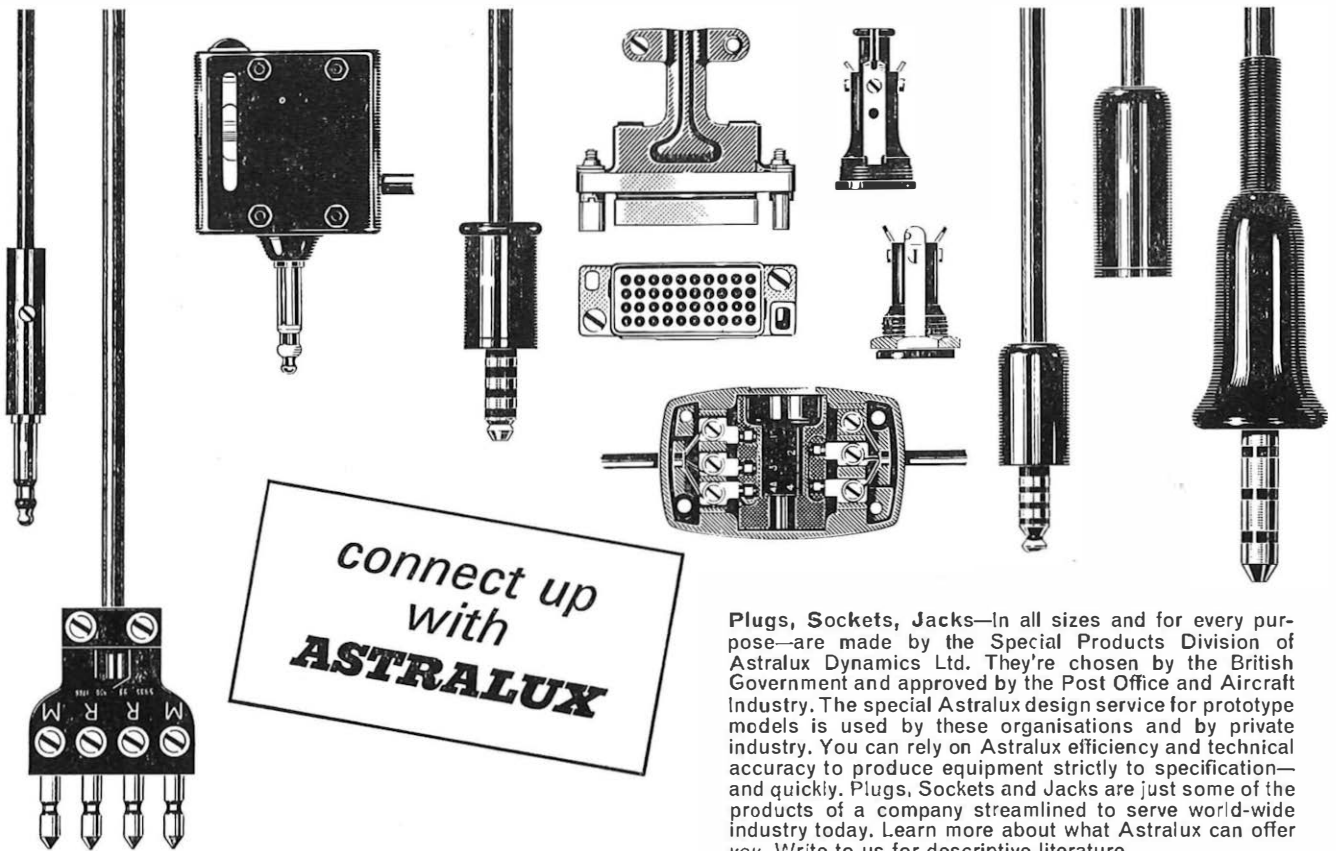

Plugs, Sockets, Jacks—in all sizes and for every purpose—are made by the Special Products Division of Astralux Dynamics Ltd. They're chosen by the British Government and approved by the Post Office and Aircraft Industry. The special Astralux design service for prototype models is used by these organisations and by private industry. You can rely on Astralux efficiency and technical accuracy to produce equipment strictly to specification—and quickly. Plugs, Sockets and Jacks are just some of the products of a company streamlined to serve world-wide industry today. Learn more about what Astralux can offer you. Write to us for descriptive literature.

**ASTRALUX** dynamics limited

Relay Division, Brightlingsea, Colchester,  
Essex, England. Tel. Brightlingsea 2571/5



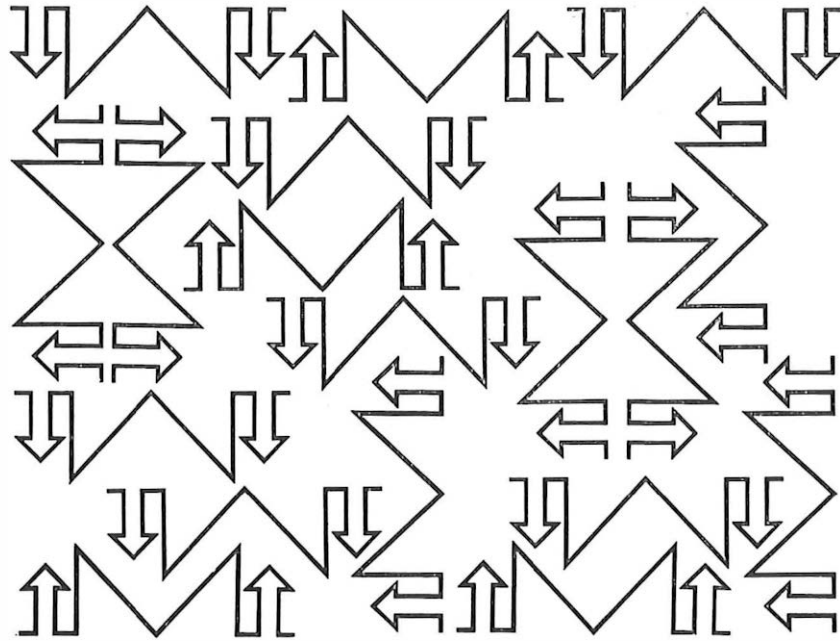

# 18 programme channels per rack

## CM-18A1 PROGRAMME MULTIPLEX

18 high-quality programme channels compatible with 60 telephone channels over the same bearer circuit. Any channel pair in a group of channels may be chosen for stereophonic programme transmission without need for pre-settings. Frequency shift eliminated by carrier regeneration at the receiving end. Non-oven oscillators are used.



Independent channels. Economic installation even with a small number of programme channels. Performance complying with CMTT\* recommendations in a 2500 km circuit with three cascaded audio modulations. No need for compandor. Automatic level control. Emphasis network complying with CCITT standards.  
\* Doc. CMTT/119 - September 17, 1968.

- |                                |  |  |   |
|--------------------------------|--|--|---|
| RADIO RELAY SYSTEMS            |  |  | DATA TRANSMISSION SYSTEMS               |
| MULTIPLEX TELEPHONE SYSTEMS    |  |  | TRAFFIC CONTROL SYSTEMS                 |
| TV AND FM BROADCASTING SYSTEMS |  |  | TELECOMMUNICATION EQUIPMENT AND SYSTEMS |

*Telettra*

## INDEX TO ADVERTISERS

Alken Precision Engineers Ltd.	.. .. .	21
Astralux Dynamics Ltd.	.. .. .	1, 21
British Institute of Engineering Technology	.. .. .	16
Civil Service Annuities Assurance Society	.. .. .	16
S. H. Collett Manufacturing Co. Ltd.	.. .. .	23
Cray Electronics Ltd.	.. .. .	24
Eddystone Radio Ltd.	.. .. .	13
Erskine Laboratories Ltd.	.. .. .	16
Ferranti Ltd.	.. .. .	8
GEC-AEI Telecommunications, Ltd.	.. .. .	10-11, 14-15
Marconi Communication Systems Ltd.	.. .. .	12-13
Plessey Co. Ltd., The	.. .. .	18
Pye Telecommunications Ltd...	.. .. .	19-20
Radiospares	.. .. .	17
Standard Telephones & Cables, Ltd.	.. .. .	2-7
Telephone Cables Ltd.	.. .. .	9
Telettra S.p.A.	.. .. .	22
Ultra Electronics Ltd.	.. .. .	1
Wandel & Goltermann (UK) Ltd.	.. .. .	25

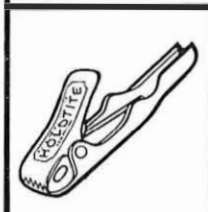
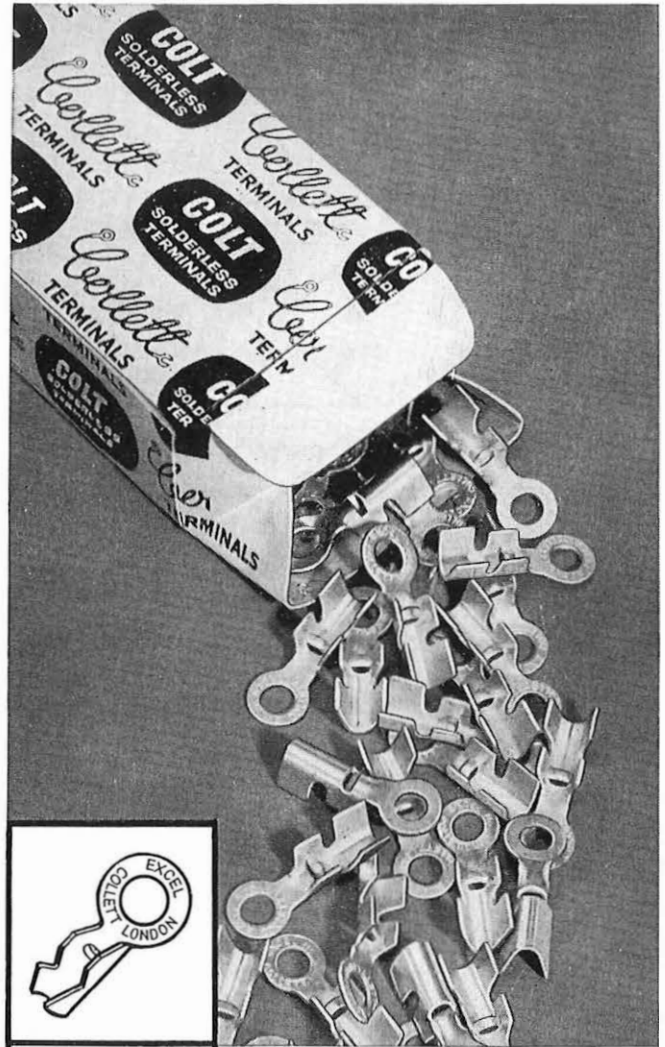

## SMALL QUANTITIES FROM STOCK

There are more than 200 different types of solder and solderless terminals, tags and clips to choose from in the famous COLLETT range. The COLLETT "small quantity" service is particularly valuable to the development engineer. Small boxes of 100 or even 10 of any type of terminal can be ordered from stock. And if none of the standard range is suitable, COLLETT will make up "specials" to meet your own requirements.

Send for fully illustrated leaflets and price lists today.

### COLLETT TERMINALS

SALES DEPT.  
347-349 GOSWELL ROAD  
LONDON, E.C.1 . 01-337 2584

# TYPE 62

## FULL RANGE

7 TO 14 DAY DELIVERY

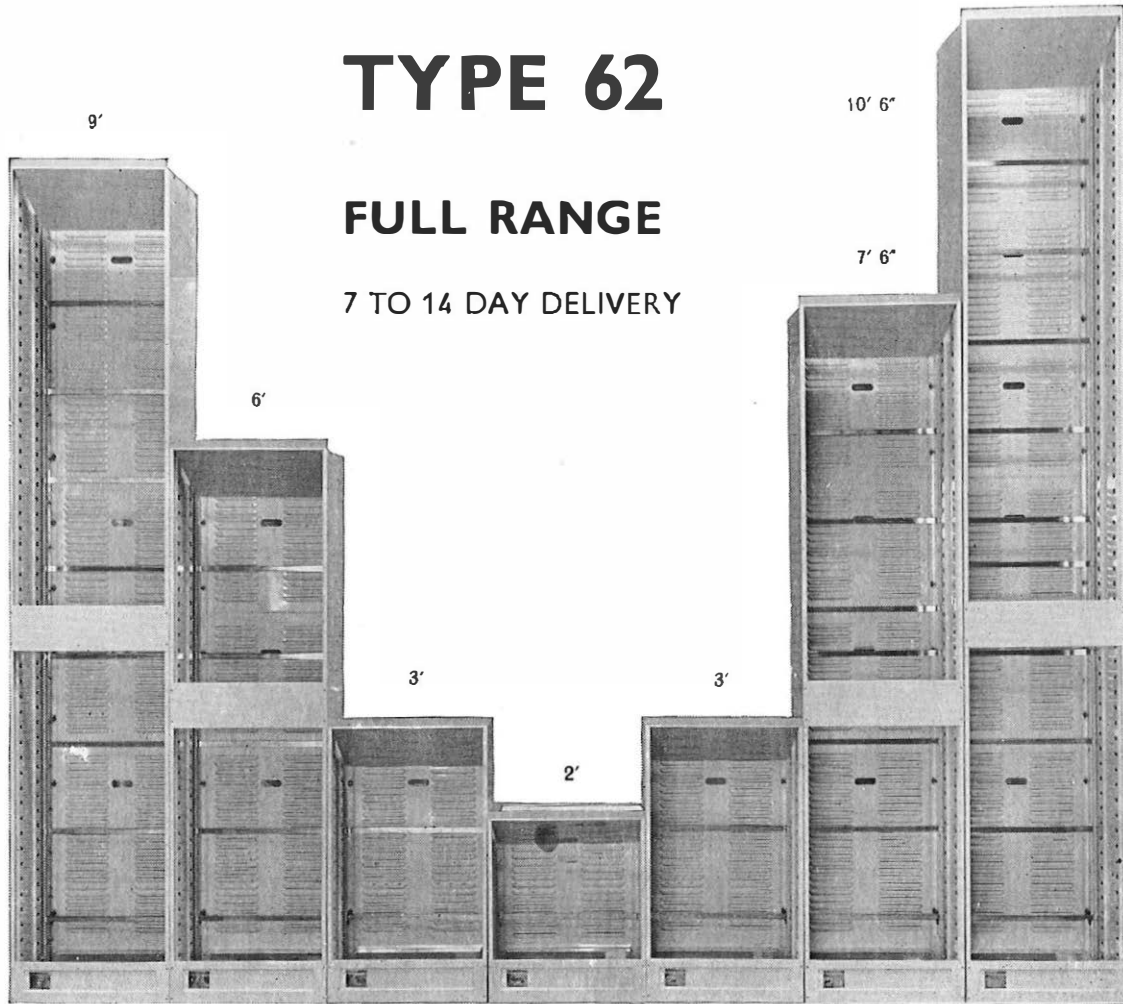

### HIGH PRECISION MECHANICS

FOR INSTRUMENT ELECTRONIC  
AND AUTOMATION INDUSTRIES

TELECOMMUNICATIONS  
MECHANICS

**P.O. APPROVED**

IMMEDIATE QUOTATIONS AND  
TECHNICAL SERVICE

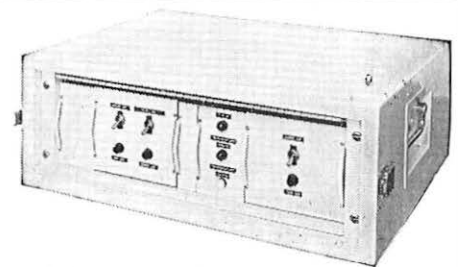

SHELF ASSEMBLIES

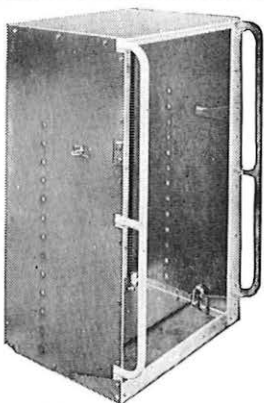

P.C.M. TRANSIT JIG



DAtEL MODEM

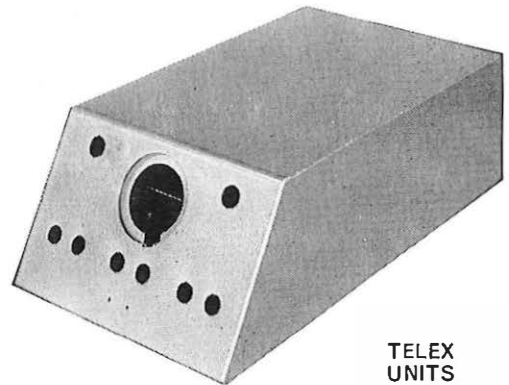

TELEX  
UNITS

**CRAY ELECTRONICS LTD**

THAMES ROAD, CRAYFORD, KENT  
TELEPHONE: CRAYFORD 26526

# Do you have Group Delay Measuring problems?

## Group Delay and Attenuation Measuring Set LD-2

To determine frequency dependant variations of Group Delay and Attenuation in the frequency range of 200 Hz to 600 KHz

For both loop and end-to-end measurements

Will measure absolute values in the loop mode

Point-by-point and sweep measurements may be made

Operates according to a modified Nyquist principle

Has a separate input level monitoring meter

High resolution—down to 1 microsecond

Evaluation and recording of test results can be made from panel meters and/or X-Y recorder

Signal Tone blocking for use over switched networks

Both ac mains and battery operation

Accurate and easy to operate

Post Office approved for use on private circuits

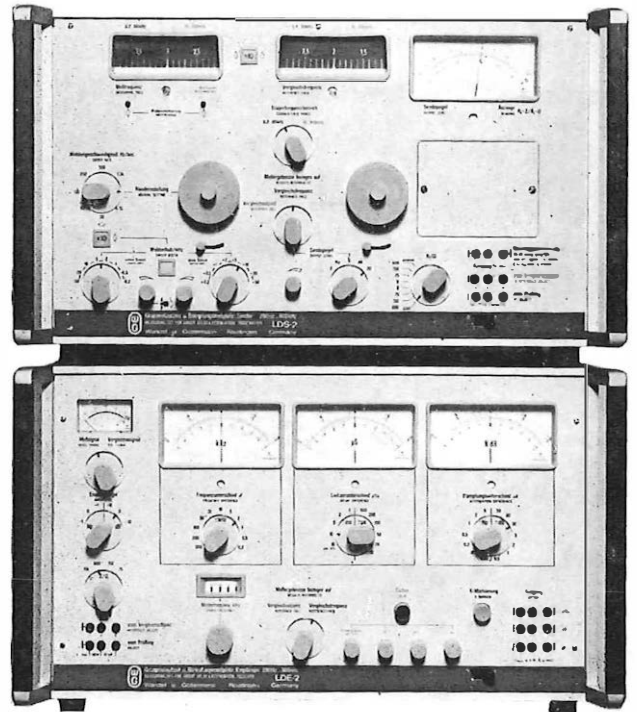

# Do you wish to make highly accurate Level Measurements up to 18 MHz?

## Level Generator PS-6 / Level Meter SPM-6

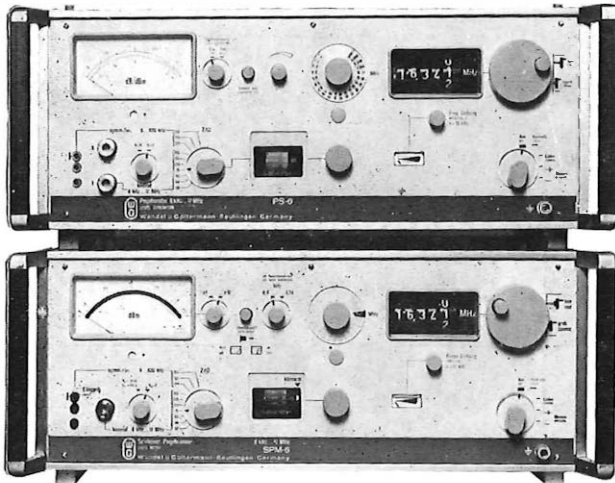

SPM-6: Measuring range  $-112$  to  $+23$  dB. Can be switched to voltage level or power level. Accuracy of the measured level 0.2 dB. Automatic level calibration. Overload check.

PS-6: Output level  $-98$  to  $+1$  dB. Can be switched to voltage level or power level. Level accuracy 0.3 dB. External amplitude modulation.

High precision portable measuring instruments

Frequency range 6 KHz to 18.6 MHz

Automatic level calibration giving high level measuring accuracy

Measuring range switchable in 2 dB steps

Level meter switchable to expanded range 20 dB or 2 dB

Level meter overload check switch

Digital display of tuned frequency

Optional 3 fixed frequency positions

High-frequency accuracy by phase locked circuit

Generator low harmonic distortion

Generator may be tuned from the receiver

Generator blanking switch provided

Switchable operation—dB or dBm

AC mains or internal rechargeable batteries

# Wandel & Goltermann (U.K.) Ltd.

40-48 High Street, Acton, London, W.3 01-992 6791