

# The Post Office Electrical Engineers' Journal

---

**VOL 63 PART 1 / APRIL 1970**



# THE POST OFFICE ELECTRICAL ENGINEERS' JOURNAL

Vol. 63 PART 1 APRIL 1970

## Contents

	<i>page</i>
<b>The Development of the Intelsat Global Satellite Communication System—Part 2— Current Earth Station Practice and Future Systems—R. E. G. Back and D. J. Withers</b>	1
<b>A Highly-Reliable Time-Pulse for Television Switching—A. C. Lander and G. E. V. Holland</b>	8
<b>Improving Underground Maintenance—Part 2—Proving a New Organisation— C. C. Thain and D. R. Wells</b>	11
<b>The London Cable-Tube System—W. H. Lamb</b>	14
<b>Measurements on Goonhilly 85 ft Diameter Aerial—Part 2—Profile Adjustment and Electrical Performance—B. A. Lowe and H. E. Pearson</b>	20
<b>The Long Lines Computer Project—B. Cross</b>	24
<b>Joining Coaxial Cables for Schools Closed-Circuit Television Networks—C. P. Self</b>	29
<b>A Land-Rover-mounted Winch—M. Doherty</b>	31
<b>Stored-Program Character Storage for Automatic Error-Correcting Telegraph Systems—C. S. Hunt</b>	33
<b>Telecommunications in Power Stations—G. A. Bartlett and A. F. Walker</b>	38
<b>Transit-Trunk-Network Signalling Systems—Part 1—Multi-Frequency Inter-Register Signalling—C. B. Miller and W. J. Murray</b>	43
<b>Testing the Safety of Leads on Electrical Appliances—V. G. W. Way</b>	49
<b>Notes and Comments</b>	51
<b>Institution of Post Office Electrical Engineers</b>	56
<b>Regional Notes</b>	57
<b>Associate Section Notes</b>	58
<b>Press Notices</b>	60
<b>Book Reviews</b>	7, 50

Published in April, July, October and January by *The Post Office Electrical Engineers' Journal*,  
2-12 Gresham Street, London, E.C.2

Price 3s. 5s. (Including Postage and Packing). Orders by post only.

Annual Subscription (post paid): Home, 20s.; Overseas, 19s. (Canada and U.S.A., 2 dollars  
50 cents).

# The Development of the Intelsat Global Satellite Communication System

## Part 2—Current Earth-Station Practice and Future Systems

R. E. G. BACK, C.ENG., M.I.E.E., and D. J. WITHERS, C.ENG., M.I.E.E.†

U.D.C. 621.396.946.001.6: 629.783

*Part 1 of this article dealt with the growth of the Intelsat satellite communication system and described the satellites in current use. Part 2 concentrates upon the changes in earth-station equipment required for operation to the new satellites and reviews developments in earth-station layout. In conclusion, a brief assessment is made of future systems and equipment developments.*

### EARTH-STATION DESIGN AND CONSTRUCTION

The equipment provided at Goonhilly radio station for operation to the Telstar and Relay experimental satellites has already been described in detail<sup>1</sup>. This article will deal only with the changes in equipment performance and station layout that have taken place since that time at typical earth stations for operation to INTELSAT III satellites. The Goonhilly No. 1 and No. 2<sup>2</sup> installations will be used as examples where appropriate. Changes in equipment characteristics and layout were inevitable to operate to the new series of satellites, but throughout this article it may be seen that other influences have also had their part to play in dictating changes to the original concept of an earth station, e.g. the need for much higher reliability for a station carrying commercial traffic.

It is worthy of note that the aerials currently being provided for the global satellite system are essentially similar to the first aerial constructed at Goonhilly (Fig. 1) in that they have no protective radome and have a parabolic primary reflector. Goonhilly No. 1 was the only aerial of this type taking part in the early satellite communication experiments. Experience has shown that the water film which develops on radomes in moderate to heavy rainfall can cause a loss in received energy of up to 4 dB<sup>3</sup>; additionally, the absorption and scattering effects of the film of water increase the effective noise temperature of the aerial, and its figure of merit (G/T)\* is seriously degraded. Service has been lost at all radome-type stations from this cause. At Goonhilly, until February 1969, the maximum signal loss observed was 2 dB and there had been no loss of service due to adverse weather conditions. In February, however, exceptionally heavy falls of snow accumulated in the bowl of Aerial No. 2 whilst it was operating to an INTELSAT III satellite, causing attenuation of approximately 4 dB to transmitted and received carriers. In areas of the world where heavy snowfalls are common, electric heating elements are installed to prevent the build-up of snow deposits in the reflector bowl.

### Mechanical and Structural Aspects of Aerials

The aerials provided and in course of provision throughout the world for operation to INTELSAT III satellites have not taken full advantage of the characteristics of the spacecraft orbit. Some aerials, e.g. Goonhilly No. 2, have been provided with a limited range of steerability in elevation and azimuth,

thereby taking advantage of the limited field of view which is sufficient for seeing all possible satellite positions in equatorial orbits. A few others have utilized a modification of the astronomical polar-mount telescope to provide aerials with only one main bearing. In general, however, administrations have been reluctant to accept the possible limitations to future service imposed by aerial mounts designed for operation to a single geo-stationary satellite, and the most common configuration is the fully steerable elevation/azimuth mount as for Goonhilly Aerial No. 1, although driving speeds have been reduced substantially to meet the requirements of tracking geo-stationary satellites.

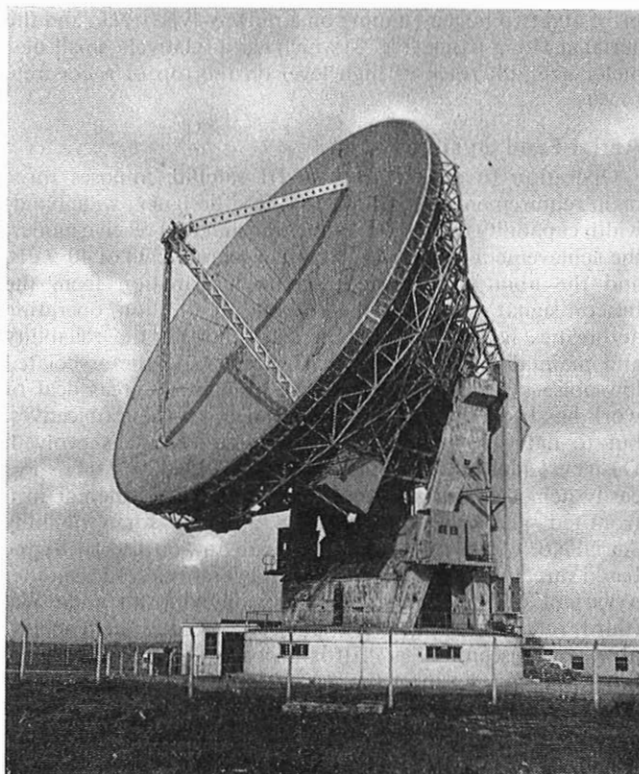

FIG. 1—Goonhilly Aerial No. 1. Built in 1961, modified in 1965 to give improved profile accuracy

† Space Communications Systems Branch, Telecommunications Development Department, Telecommunications Headquarters.

\* For explanation, see part 1.

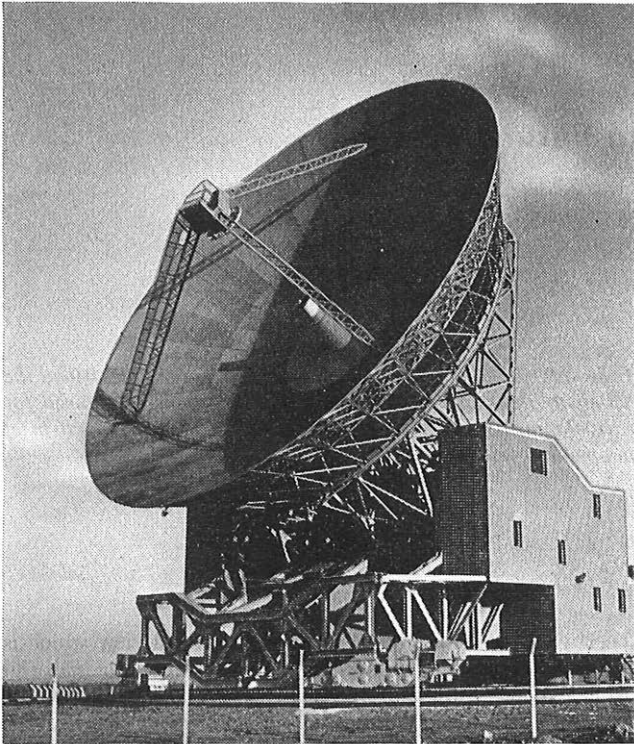

FIG. 2—Goonhilly Aerial No. 2, built in 1968. The ground-level azimuth track and two drive bogies can be observed.

Structurally, two main types of aerial have been designed for operation to an INTELSAT III satellite. The differences are typified by the second aerial at Goonhilly (Fig. 2), which has a ground-level azimuth bearing consisting of a central pivot and two bogies running on a railway-type track, and the aerial at Hong Kong (Fig. 3) which has a relatively small diameter azimuth track at high level on the top of a concrete tower.

### Aerial-Feed Systems

Operation to an INTELSAT III satellite imposes three main requirements upon the aerial-feed designer; wide bandwidth capability (500 MHz) in the transmit and receive modes, the achievement of a receive figure of merit ( $G/T$ ) of 40.7 dB, and the ability to derive tracking information from the beacon signal emitted by the satellite. In addition, operating authorities have urged designers to improve the reliability and maintainability of the feed systems and the associated low-noise amplifiers and tracking systems. A great deal of work has been put into the achievement of these objectives, but to date no universally accepted solution has evolved. Designers have clearly concluded that a 40.7 dB  $G/T$  is less easily achieved with the long waveguide runs inherent in a front-fed parabolic configuration as used for Goonhilly Aerial No. 1. Two main approaches can now be discerned; one based directly on Cassegrain optical telescopes, and the other a variant of these principles and employing an additional (third) reflecting surface. The short waveguide system achievable can be seen in Fig. 4. It is probable that either of these latter systems can meet the performance requirements when associated with a main reflector of 90–100 ft diameter and give acceptable reliability and maintenance space.

For operation to a geo-stationary satellite the range of aerial movement required is small, but because the beamwidth of the aerial is approximately 6 minutes of arc between the 3 dB points, the aerial must be pointed directly at the satellite at all times if service is to be maintained. A fixed aerial will not suffice because the satellite is not truly geo-

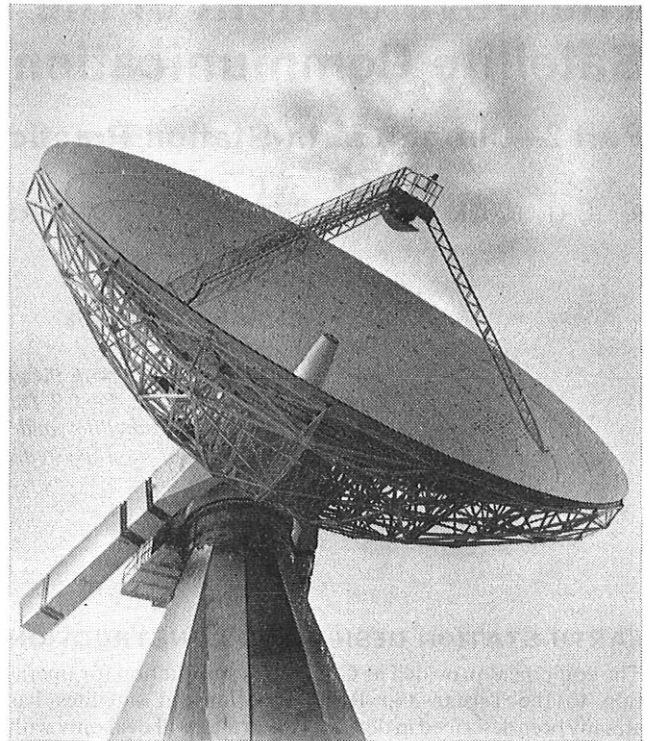

FIG. 3—Aerial at Hong Kong, built in 1969. The high-level azimuth track at the top of the concrete tower can be seen clearly.

stationary, i.e. it tends to move relative to the earth, and also because wind forces on the aerial tend to deflect its electrical axis. To control the movement of the aerial it is usual to incorporate a servo system in association with the drive motors. The servo system obtains information on the pointing error of the aerial from a beacon signal emitted by the satellite and uses the error signal to drive the aerial so as to minimize the error.

To derive tracking information from the satellite-borne beacon for use in an auto-track system, the aerial-feed system must include components which, in conjunction with a receiver, give an output signal proportional to the tracking error. In one system, known as conical-scan, the main beam of the aerial is caused to rotate off-centre and thus, whenever there is a tracking error, the received beacon signal is amplitude modulated with the amplitude of the modulation proportional to the magnitude of the pointing error and its phase a function of direction. The conical-scan system has disadvantages in that careful design is required to ensure that the scanning action which produces the amplitude modulation in the received beacon signal does not similarly modulate the transmitted carriers and thereby, by a crosstalk mechanism in the satellite, modulate the beacon and all carriers transmitted from the satellite. Additionally, the rotary scanning action normally requires the feed unit or the sub-reflector to be rotated mechanically, and this introduces a reliability problem at a critical and relatively inaccessible point in the system. Tracking systems having no moving parts have been developed, e.g. the mono-pulse system,<sup>4</sup> but these generally affect the efficiency of the main communication system because there must be a compromise between aerial efficiency and tracking sensitivity. For the conical-scan system, the feed unit can be designed for optimum aerial efficiency. Static systems are now finding greater favour, but their lower aerial efficiency, coupled with the use of longer waveguides to provide easier access to low-noise amplifiers, has led to the size of aerials increasing from the "standard" 85 ft diameter to 90–100 ft.

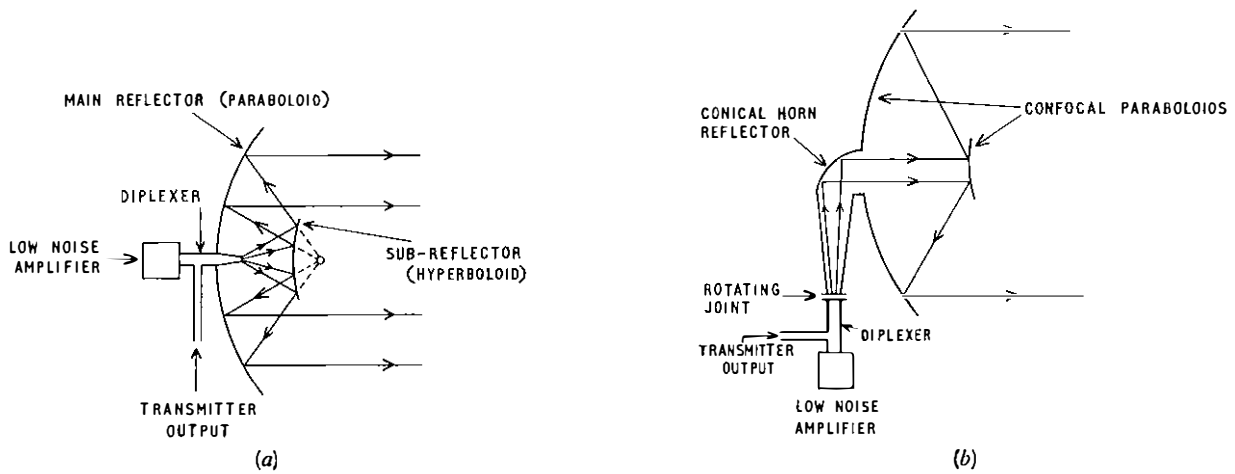
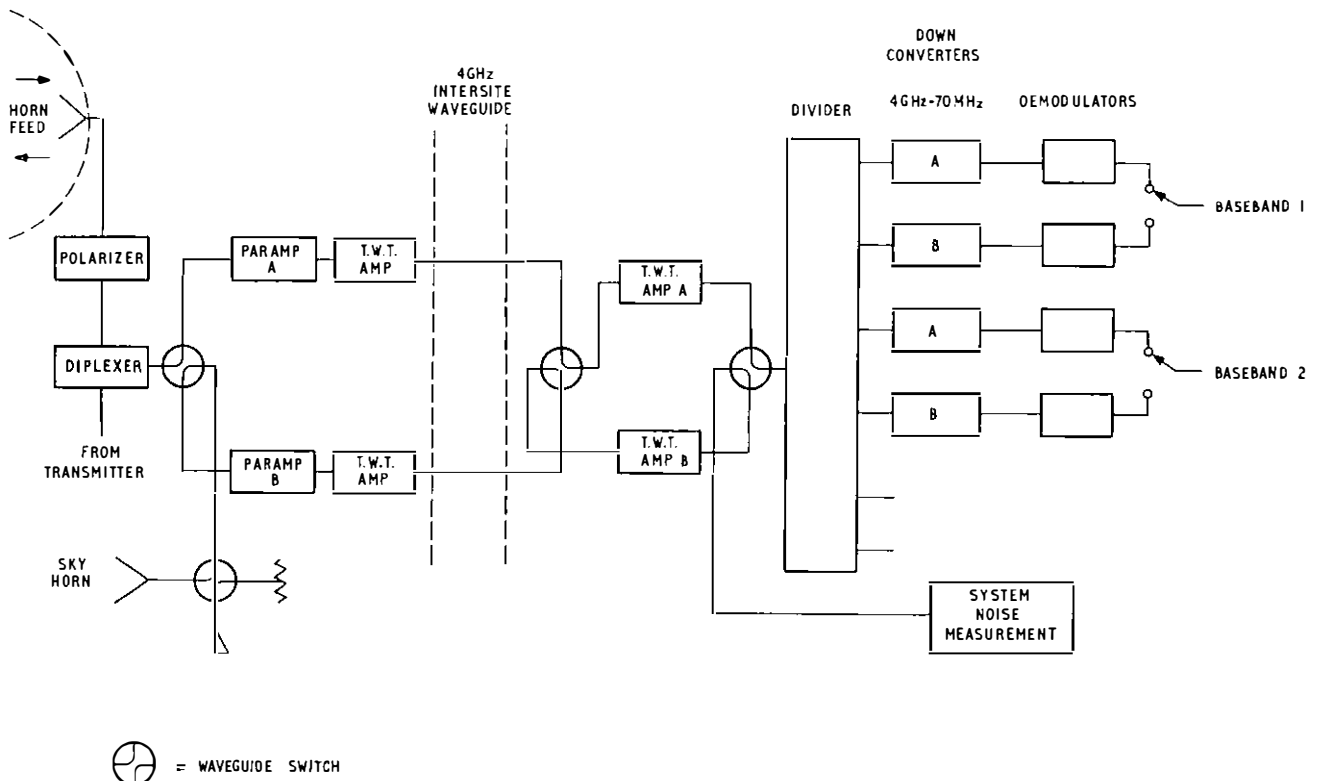

FIG. 4—Illustrating the principle of (a) Cassegrain, and (b) Horn-Fed Cassegrain, Aerials



 = WAVEGUIDE SWITCH

Note: T.W.T. indicates travelling-wave-tube.

FIG. 5—Simplified block schematic diagram of receive equipment

## THE RECEIVE SYSTEM OF THE EARTH STATION

A simplified block-schematic diagram of the receive side of a typical earth station is shown in Fig. 5 and the main components will be briefly described.

### Low-Noise Amplifiers

The need to receive carriers anywhere within a 500 MHz bandwidth precludes the use of the inherently narrow-band maser amplifiers which were provided at earth stations for use with earlier satellites. Nevertheless, the received signal level from an INTELSAT III satellite (of the order of  $10^{-13}$  watts) is such that a low-noise receiver is essential. To meet the bandwidth and noise temperature requirements, cooled parametric amplifiers<sup>5,6</sup> have been developed giving 500 MHz bandwidth at an effective noise temperature of 15–20° Kelvin

when cooled to a physical temperature of approximately 16° Kelvin. The gain of the cooled section is approximately 30 dB, and this is usually followed by a tunnel-diode amplifier giving a further 10 dB of gain. Cooling by batch-filling with liquid helium as has been the practice in the past is costly in skilled manpower and involves amplifiers being taken out of service at approximately daily intervals for re-filling. Continuously-operating cryogenic cooling devices using gaseous helium as a coolant have now been developed, and these require routine maintenance attention at intervals of 2,000–3,000 hours.

### Down Converters and Inter-site Connexions

Recalling that each earth station will need to receive a carrier from each country with which it wishes to communicate, it will be seen that at all earth stations it will be necessary to separate relatively narrow-band individual carriers from

the 500 MHz output from the low-noise amplifiers. In addition to the basic problem of carrier separation, the equipment provided should be capable of coping readily with the changes of carrier frequency and capacity which the developing system will undoubtedly require. A satisfactory arrangement, combining economy of equipment space and flexibility in operation, is shown in Fig. 6.

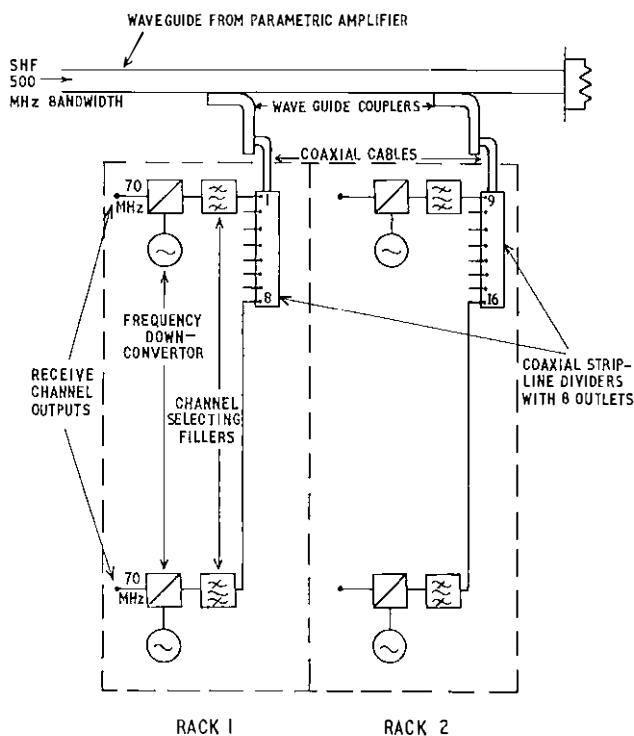

FIG. 6—Receiver branching network

In laying out their sites, most earth-station owners have assumed that eventually more than one aerial will be required; they have therefore opted for a central building with separate sites for a number of aerials each some 300 yards away. This is a convenient arrangement because it brings together the communication equipment, the control and monitoring equipment, and the baseband equipment which are common to all systems and thereby centralizes a large proportion of the equipment which has to be maintained.

The carrier separation equipment may be located at the aerial or in the central building. If the individual carriers are derived at the aerial site, they are extended to the central buildings by coaxial cables operating at intermediate frequency (70 MHz), but if the carrier separation takes place at the central building, the 500 MHz receiver bandwidth is extended from the aerial at s.h.f., using waveguide. The waveguide used is of the flexible, elliptical type. At Goonhilly both systems are in use for inter-site connexion.

### Intermediate-Frequency Equipment and Demodulators

The intermediate-frequency equipment (70 MHz) provided at an earth station is of conventional design and similar to that used in line-of-sight microwave links. Within this section of the equipment the group-delay occurring within the earth station is equalized and inop-up for that in the satellite is included.

Planning for the INTELSAT III system is based upon the assumption that demodulators giving threshold extension are used to provide a margin of protection against degradation

of received carrier-to-noise ratio. Currently, demodulators of the frequency-modulation-with-feedback (f.m.f.b.)<sup>7</sup> type or phase-lock loop type are in use at earth stations. An interesting development is a demodulator using a narrow-band tracking filter, the centre frequency of which is made to follow the frequency variations of the incoming, frequency-modulated signal. Demodulators of this type as well as f.m.f.b. demodulators have been installed at Goonhilly.

The threshold extension required for the global system can be achieved (although with little margin) by currently available equipment, and immediate development is concentrated upon equipment which is less complex and easier to maintain.

### Baseband Assembly

To improve satellite power and frequency spectrum utilization, all telephony basebands have a lower frequency of 12 kHz. The telephone channel capacities of carriers over the satellite system are standardized at 24 (12–108 kHz), 60 (12–252 kHz) and 132 (12–552 kHz) channels. Special interface equipment may be required to interconnect standard terrestrial systems and the special channel assemblies used over satellite systems.

The sub-baseband frequencies from 0–12 kHz are utilized for energy dispersal (0–4 kHz) and service circuits (4–8 kHz and 8–12 kHz). The need for energy dispersal was outlined in Part 1 of this article. Briefly, it is incorporated in the satellite system to ensure that at all times energy is spread across the available spectrum and high-energy peaks at periods of light traffic loading are eliminated. In the global system it is obtained by applying a low-frequency (20–150 Hz) symmetrical triangular waveform in the 0–4 kHz channel of the baseband. The amplitude of the energy dispersal waveform is adjusted, either continuously or in steps, so that regardless of the traffic loading, the maximum equivalent isotropically-radiated power (e.i.r.p.) per 4 kHz of transmitted bandwidth does not exceed the e.i.r.p. per 4 kHz of a fully-loaded carrier by more than 2 dB.

Two engineering-service-circuit channels are provided in the 4–12 kHz portion of the baseband. In addition to the speech channel, which has in-band signalling, each service circuit can carry up to five telegraph channels in the range 2,640–3,240 Hz. At present, the engineering circuits for speech and telegraphy are terminated on switchboards at the earth stations and extended as required. Ultimately an automatic system is planned using a 3-digit code.

### THE TRANSMIT SYSTEM OF THE EARTH STATION

Fig. 7 shows a simplified block schematic diagram of the transmit equipment at a typical earth station.

#### Modulation and Intermediate-Frequency Equipment

The baseband, modulation and intermediate-frequency equipment provided at earth stations for each transmitted telephony carrier is similar to that provided for line-of-sight microwave links. Equipment is included to equalize the group-delay occurring within the transmitting equipment at the earth station plus some pre-equalization for group-delay occurring in the satellite.

#### Intersite Connexions

As mentioned in Part 1 of this article, multi-destination carriers are used to reduce the number of emissions from earth stations; consequently, at most earth stations the number of transmitted carriers is much lower than the number received, and coaxial links at i.f. are competitive with waveguides for intersite connexions. There are advantages for maintenance testing in retaining symmetry, however, if a wideband link has been adopted on the receive side; furthermore, the use of

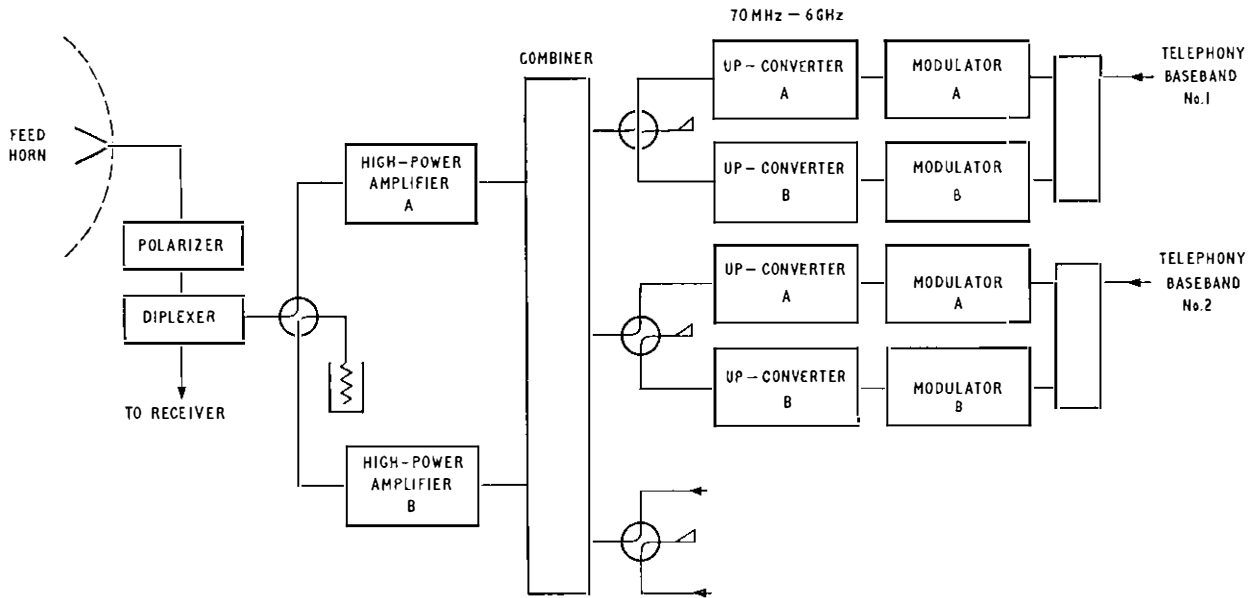

FIG. 7—Simplified block schematic diagram of transmit equipment.

wide-band interconnexions in both transmit and receive directions facilitates the provision of flexibility between aerials, should this be required.

### The Transmitters

The e.i.r.p. per carrier required for operation to an INTELSAT III satellite is dependent upon the geographical position of the communicating earth stations and the gain of the satellite transponder. Table 1 quotes the values of e.i.r.p. internationally agreed and promulgated as a guide to earth station owners.

**TABLE 1**  
**Transmitted E.I.R.P. to INTELSAT III Satellites**

Carrier Size	e.i.r.p. (dBW)	Transmitter Output Power (Watts) for 59 dB Net Aerial Gain
24 Channel	74.8	38
60 Channel	78.8	95
132 Channel	82.2	210
Video	86	510

Taking into account the gain of the aerial at 6 GHz and the loss of the transmit waveguide, the power required from the transmitter varies from 38 watts for a 24-channel carrier to 210 watts for a 132-channel telephony carrier, whilst a television video-carrier requires an output of 510 watts. The television carrier is radiated at a fixed frequency, but the telephony carriers may be required to radiate at any nominated frequency in the 500 MHz of available bandwidth. Two main methods of meeting the requirements are available using either narrow-band transmitters based upon the klystron (30–50 MHz bandwidth) or wideband transmitters based upon the travelling-wave-tube (500 MHz bandwidth).

Using klystrons, each carrier to be transmitted is amplified to the appropriate output level in a separate transmitter and the outputs of the transmitters combined before connexion to the aerial feed. Complications arise from the narrow-band characteristics of the transmitter tube and the requirement for standby equipment to provide adequate reliability of service.

Re-tuning of klystron transmitters is a relatively lengthy process and it is usual to provide one standby for each working transmitter. Clearly, this arrangement becomes less attractive as the number of carriers to be transmitted increases.

For the travelling-wave-tube system, the carriers to be transmitted are combined at low power and then amplified by the wide-band transmitter prior to connexion to the aerial. The travelling-wave-tube amplifier is inherently a non-linear device and thus, when a number of carriers are amplified by the same tube, there are intermodulation products present at the output. Third-order intermodulation products may fall within the 500 MHz transmitted bandwidth and could cause interference to the carriers of other earth stations. To limit this type of interference to an acceptable level, a limit of +23 dBW e.i.r.p. has been set to the level of intermodulation products occurring in any 4 kHz band of an earth station's emissions over the 500 MHz transmitting bandwidth. To reduce the level of the intermodulation products occurring within an amplifier, it is necessary to reduce the level of the emitted carriers well below the level which would be expected from consideration of the single-carrier saturation power of the device and the number of carriers involved. Travelling-wave-tubes having 500 MHz bandwidth and 8–10 kW single-carrier saturated-output-powers are available, but the restriction of the level of intermodulation products may limit the number of 132-channel telephony carriers through any amplifier to three. The actual e.i.r.p. to be transmitted per carrier may be lower than standard due to a number of factors associated with the actual performance of the satellite and the geographical location of the earth station, and in practice the number of carriers per transmitter can be increased.

### TELEVISION

For clarity, the description of equipment chains given previously in this article concentrated upon the telephony aspects. However, satellite communication has opened up a new field of intercontinental television transmissions. Such programs have now become almost routine and a brief description of the equipment provided and facilities available at the earth station for these transmissions may be of interest.

Television service in the INTELSAT III system will be

improved in two ways compared with the Early Bird transmissions. Firstly, 40 MHz of the available bandwidth is permanently allocated for television and it will therefore be possible to carry programs when required without interruption of the telephony services. Secondly, the power and bandwidth allocated to television are such that superior performance can be obtained, particularly for colour television, when over-deviation techniques are employed. The performance achieved falls little short of the quality recommended by C.C.I.R.\* for intercontinental transmission.

The reception of video transmissions from the satellite involves the provision of a receive chain of equipment with a nominal 25 MHz bandwidth. No special problems are involved and the received carrier level is sufficiently far above the threshold value for conventional wide-band demodulators to be used. Most earth stations are equipped to receive television programs.

It is a matter of choice whether the expense involved in transmitting television material is worthwhile, and some countries do not provide this facility. The equipment required for video transmission is similar to that needed for telephony carriers, although a wide-band modulator is required to provide the necessary linearity. The e.i.r.p. required for a video carrier is 86 dBW, i.e. some 510 watts at the transmitter output, and if a carrier of this size were passed through a common output tube with the telephony carriers, the inter-modulation resulting would normally be unacceptable. It is generally concluded that the cost of a separate transmitter for television is not justified by the occasional nature of the traffic, and use is therefore made of the standby telephony-transmitter. The arrangement is outlined in Fig. 8 and it will be noted that in the event of failure of the main transmitter during a television transmission, the telephony traffic is switched to the standby and the television is interrupted.

Associated with the video carrier are two 24-channel carriers, one for each direction of transmission. The 24-channel carrier transmitted by the earth station transmitting the video signal carries an 11kHz program channel plus multi-lingual commentary channels when required, cue circuits and engineering order-wire circuits. The carrier in the return direction carries cue and order-wire circuits only. Earth stations which transmit and receive television programs must be equipped to alter the frequency of their 24-channel carriers depending on whether they are transmitting or receiving. This facility is normally provided by switching local oscillators rather than by the provision of additional equipment.

## RELIABILITY OF EARTH STATION

The importance of the international traffic carried by satellite circuits is such that earth-station owners insist upon very high reliability, and a service availability of 99.9 per cent is often required, i.e. not more than 8 hours out-of-service time per year.

Service of this order can only be obtained by using equipment of proven reliability and by providing reserve equipment which is automatically switched into circuit in the event of failure of the main equipment. Even with this scale of equipment provision it is essential to provide a central monitoring console from which the operation of the whole station can be observed and directed. Furthermore, it is essential to have competent staff available at all times to deal with faults and to maintain the equipment.

## FUTURE DEVELOPMENT

### Satellites

The INTELSAT system traffic in the Atlantic Ocean zone in 1970 is more than one INTELSAT III satellite can carry,

\* C.C.I.R.—International Radio Consultative Committee.

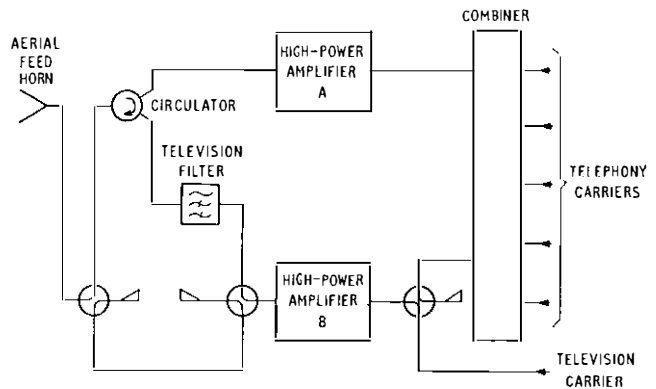

FIG. 8—Television transmission via standby high-power amplifier

and the Pacific Ocean zone satellite will be fully loaded by 1971. More powerful satellites are needed, able to carry all the traffic of these zones for some years to come. A contract for the development of the next generation of satellites, INTELSAT IV, was placed in October 1968, and the first of a batch of four spacecraft should be ready for launching early in 1971. These will have twelve transponders, each with a bandwidth of 36 MHz. Each satellite is expected to provide a high-quality television link and 4,000 to 5,000 two-way telephony circuits, which should be enough for the Atlantic zone for several years.

## Transmission Systems

Frequency-modulated carriers with f.d.m. basebands will be used initially with INTELSAT IV satellites, as with current types of satellite, but other methods of modulation, permitting more intensive use of the satellite medium, are being studied. Some systems, using pulse-code-modulation (p.c.m.) and very high-speed time-division multiplex, would combine large numbers of telephone channels transmitted from several earth stations into a single stream, fully loading one satellite transponder. Another p.c.m. development, expected to have considerable value in increasing the usefulness of the satellite medium to small-scale users, employs a separate r.f. carrier for each telephony channel, a large number of carriers in frequency-division-multiplex being allocated to each transponder.

## Echo Suppression

The Early Bird tests of customer reaction to long-delay telephone circuits did not indicate unqualified approval for telephone circuits routed via one stationary satellite. It has been generally accepted that it would be bad practice to route circuits through two such satellites in tandem. Some of the studies indicated clearly that more customers had difficulty with satellite circuits than with cable circuits, but the actual causes of difficulty were not positively identified. The two most likely causes are:

- (a) the interposition of a transmission delay of 270 milliseconds or more between speakers may be a subjective impediment to conversation, regardless of the other technical characteristics of the link, and
- (b) the best available echo suppressors may inhibit conversation, by mutilating speech or blocking the speech path in one direction or the other when it is wanted.

Laboratory studies now in progress and others planned will show whether difficulty arises when no echo is possible (i.e. if the circuit is 4-wire throughout and free from crosstalk) and no echo suppressor is present. If the results indicate that the problem is not purely subjective, it may be feasible to develop echo suppressors which interfere less with the flow of conversation. Apart from the further refinement of types already in use, several new principles of operation have been



suggested in recent years, and one of these might solve the problem. Perhaps the most promising new method being considered uses adaptive networks in parallel with the echo path to cancel out the echo,<sup>8</sup> leaving both directions of the circuit open for conversation all the time.

### Earth Stations

Equipment for earth stations is already changing rapidly. No country can have a large home market for this type of equipment, and intense international competition is leading to great efforts to introduce new layouts and new equipment to improve station reliability and maintainability as well as to reduce costs. In addition, it is inevitable that the introduction of a new generation of satellites and digital transmission methods will bring about changes in earth-station practice.

The narrow-band transponders (36 MHz) to be used in INTELSAT IV coupled with the requirement for greater earth station c.i.r.p. for a given carrier size mean that the case for klystrons as compared with travelling-wave-tubes for the earth station transmitters has to be reviewed. The higher received carrier levels, however, may well lead to the elimination of threshold extension devices unless, by their retention, a significant reduction in the guard bands between carriers can be obtained.

### REGIONAL SYSTEMS

Any review of future developments in satellite communication systems, however brief, would be incomplete without a reference to regional systems for telephony and television distribution. Schemes of this type are under active consideration in many parts of the world, and some are expected to be in service, perhaps on an experimental basis, by 1972-73. The use of satellites for this purpose has clear advantages in large, thinly-populated areas or countries where communication by more conventional methods is prohibitively expensive.

Even in more populous areas such as Europe, there may be economic advantages in using satellites for the longer telephony circuits and television distribution to national centres. Such systems will utilize geo-stationary satellites with highly directional beams which provide sufficient gain to permit the use of relatively small aerials at the earth stations. Some earth stations of high capacity could use aerials of about 60 ft diameter, but those required to receive television and only a few telephony circuits will need aerials of 20-30 ft diameter. The satellites for these regional systems may be provided by or in conjunction with INTELSAT, but irrespective of the method of provision, since all will make demands on the limited space in the geo-stationary orbit, close co-operation will be required to avoid interference between systems.

### ACKNOWLEDGEMENT

The authors wish to thank Cable and Wireless, Ltd., for permission to publish the photograph of the Hong Kong aerial.

### References

- <sup>1</sup> TAYLOR, F. J. D. Equipment and Testing Facilities at the Experimental Satellite Ground Station, Goonhilly Downs, Cornwall. *P.O.E.E.J.*, Vol. 55, p. 105, July 1962.
- <sup>2</sup> Goonhilly's Wonderful Ear. *Post Office Telecommunications Journal*, Spring 1969, Vol. 21, No. 1.
- <sup>3</sup> BLEVIS, B. C. Rain effects on radomes and antenna reflectors. I.E.E. Conference on the Design and Construction of Large Steerable Aerials, 1966, p. 148.
- <sup>4</sup> MARTIN and SCHWARTZMAN. A Monopulse Cassegrain Antenna. *I.R.E. Int. Conv. Rec.* 8, Pt. 1, 1960.
- <sup>5</sup> The Principle and Possible Application of Some Amplifiers of Low Intrinsic Noise. *P.O.E.E.J.*, Vol. 52, p. 212, Oct. 1959.
- <sup>6</sup> DAGLISH, H. N., ARMSTRONG, J. G., WALLING, J. C., and FOXWALL, C. A. P. Low Noise Microwave Amplifiers, I.E.E. Monograph No. 2.
- <sup>7</sup> I.E.E. Colloquium on Threshold Extension Techniques, Colloquium Digest No. 1968/9.
- <sup>8</sup> SONDHI, M. M. An Adaptive Echo Canceller. *B.S.T.J.*, Vol. XLVI No. 3, March 1967.

---

## Book Reviews

"Problems in Electrical Engineering (Power Engineering and Electronics) with Answers". N. Parker Smith, B.Sc., F.I.E.E. Constable & Co. Ltd. xvi+336 pp. 35s.

The introduction for this book deals with units, and contains a table of physical constants and also typical curves of magnetization, hysteresis, thermionic valve and transistor characteristics etc., for use in working out the answers to the questions. The rest of the book consists entirely of some 1,782 electrical engineering problems and the answers to them. Virtually the whole field of electrical engineering is covered, the subjects of the questions ranging, on the power side, from simple electro-mechanical conversions through a.c. and d.c. circuits to the design of machines and of transmission and distribution systems and, on the light current side, from tuned circuits and filters through valve and transistorized amplifiers to radio propagation and aerials.

Unlike the questions and answers published in the regular supplement to the *Post Office Electrical Engineer's Journal*, the working to arrive at the answers is not included in this book and this undoubtedly detracts from its usefulness to students.

The preface to this new edition states that the book is written entirely in metric units but, despite this, the very first question asks for the horse-power of an engine to be calculated.

M. H. J.

"Electrical Variable Speed Drives." E.E.V.A. Handbook No 29. Constable and Co. Ltd. viii+23 pp. 13 ill. 22s. 6d.

Produced by the Engineering Equipment Users Association, this handbook aims to give guidance on the selection of electrical variable-speed drives.

Compressed into a mere 23 pages is a considerable amount of information on the commonly-used types of variable speed drive, prefaced by a page of definitions and followed by four tables which tabulate some 25 characteristics of 13 types of drives in each of the ranges 1-10 H.P., 11-100 H.P., 101-1,000 H.P. and over 1,000 H.P.

The tables are in very small print and would be well worth reproducing to a larger scale. The information in some respects, e.g. size of machines available, will date fairly rapidly and ought to be revised from time to time.

The handbook is designed for rapid reference and does not take the place of normal textbook studies. It does not provide detailed design information but points quickly to the types of drive likely to be suitable, and available for any particular purpose. It can be recommended.

R. W. H.

# A Highly Reliable Time-Pulse for Television Switching

A. C. LANDER and G. E. V. HOLLAND†

U.D.C. 621.373.44: 621.397.743.06

*New sound and vision switching equipment installed in the television-network switching centres, requires a continuous feed of accurate time-pulses. A new time-pulse generating equipment, synchronized to the speaking clock (123) service, has been designed and constructed. Four equipments have been installed so far and are giving good service.*

## INTRODUCTION

Four television switching centres to date, have been equipped with electro-mechanical television-network switching equipment<sup>1</sup> of new design and increased capacity. This equipment enables a pattern of sound and vision program interconnections to be pre-set and switched automatically at the desired time. The 24-hour clock unit in the switching equipment requires an uninterrupted supply of driving pulses, at repetition rates of both 1 pulse per second and 1 pulse every 10 seconds. The agreed time-standard is that of the nationally-distributed 123 (TIM) service and all clock-driving pulses are held in synchronism with these signals. The reliability and accuracy of the time-pulse generator is fundamental to the satisfactory operation of the main switching equipments. Each set of switching equipment must be synchronized to within  $\pm 0.05$  seconds, as they may all be required to switch at the same instant. The new time-pulse generator replaces an existing electronic program clock for television network switching<sup>2</sup> which was installed in the London switching centre early in 1959. The program clock had a very low fault rate, and in the last four years of service there were only three failures that resulted in loss of program time, one of these being an engineer's working fault. Great care has been taken to ensure that this high standard of service is maintained.

## EQUIPMENT CONSTRUCTION

The time-pulse generator comprises four plug-in units (see Fig. 1), each unit housing printed-circuit boards and

† Line and Radio Systems Branch, Telecommunications Development Department, Telecommunications Headquarters.

solid-state devices. Two units, clock unit A and clock unit B, identical electrically, supply 1-second and 10-second pulses derived from tuning-fork-controlled master oscillators. The third unit monitors the outputs from both clock units and provides the necessary control and alarm facilities. The fourth unit, the regulator, provides three separate 15-volt regulated supplies from the station 24-volt d.c. supply.

Fig. 2 is a simplified block diagram of the time-pulse generator. In clock unit A, the output from a 500 Hz tuning-fork-controlled oscillator is divided by 5,000 in two stages,  $\div 500$  and  $\div 10$ , to provide a continuous train of 1-second and 10-second pulses. The reset-pulse generator takes its input from the local 123 supply and brings the divider chain into synchronism with the pips once every 10 seconds. The 1-second and 10-second pulses are gated from the divider chain and occur 200 milliseconds in advance of true time, due allowance is thus made for the operating delay of the electro-mechanical devices within the main switching equipment. The monitor unit consists mainly of two identical sub-units, one processing the 1-second pulses, the other processing the 10-second pulses. Each sub-unit serves to compare the pulses from the two clock units and provides a synchronizing-failure alarm should the pulses from the two sources be either out-of-step or of unequal duration. Either source may be used to drive the main switching unit and, if the working source fails, an automatic changeover takes place. This unit also converts the electronic pulses from the working clock-unit, to loop pulses by means of mercury-wetted-contact relays, one for the 1-second pulses and one for the 10-second pulses. These relays are very reliable, but nevertheless a comparison is made in the main switching unit which gives an alarm if a 10-second pulse does not occur in

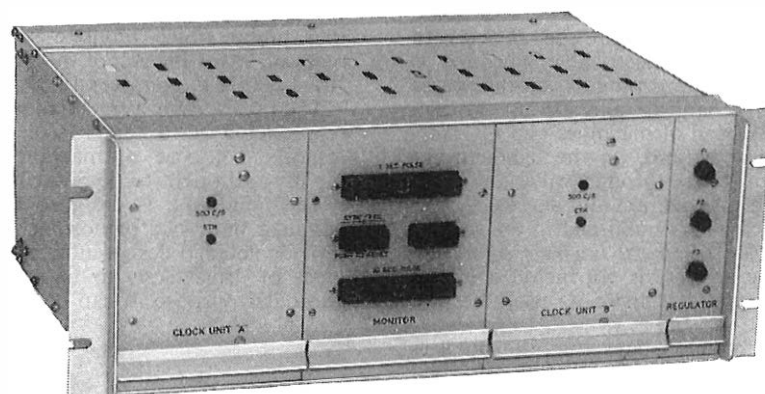
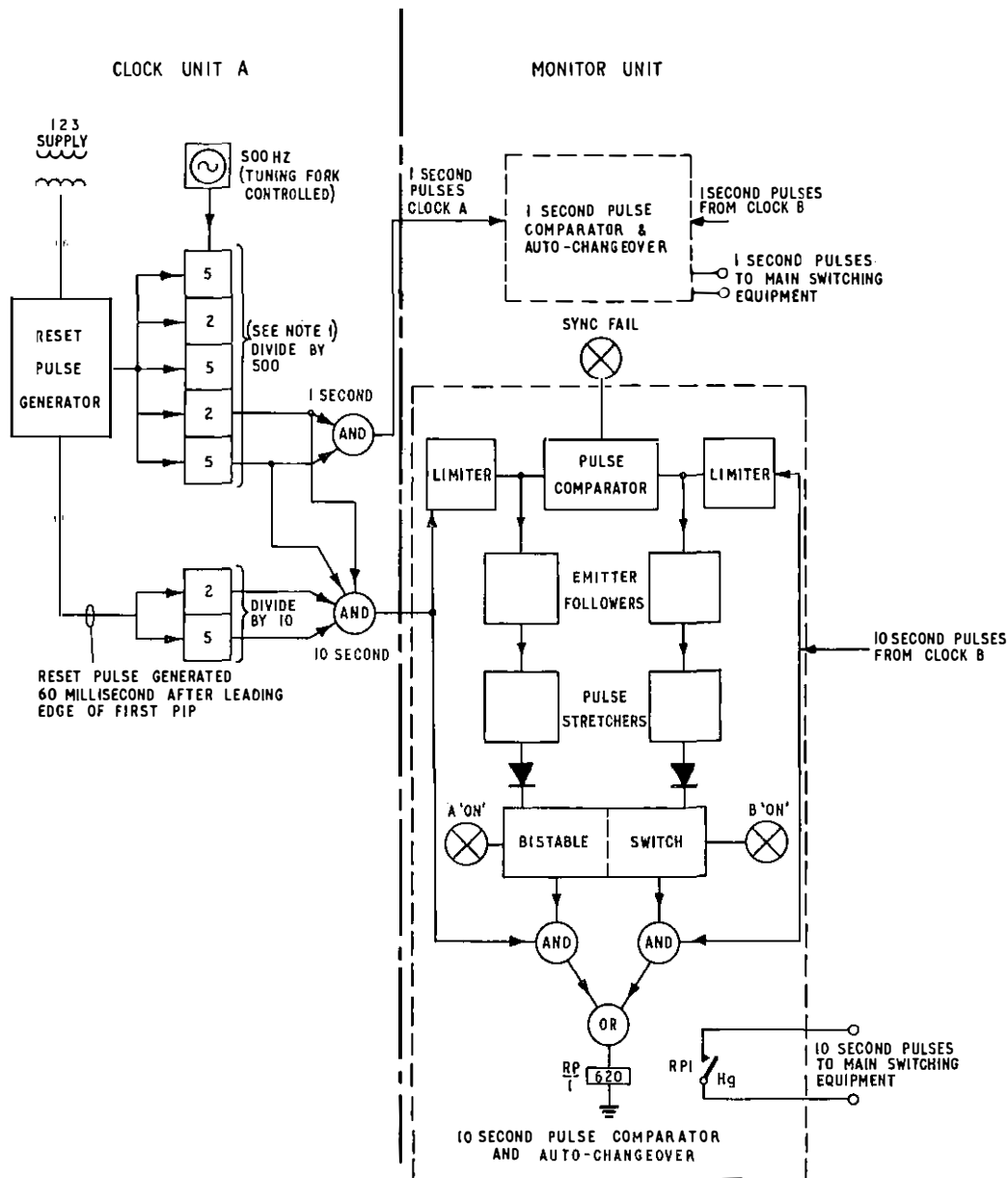

FIG. 1—Physical design of time-pulse generator



NOTE 1: Divider chain using three binary pairs with feed-back to divide by five and one binary pair to divide by two.

FIG. 2—Block schematic diagram of pulse generator

synchronism with every tenth 1-second pulse. The monitor unit also provides the necessary control and supervisory facilities, and monitors the incoming 123 signal level with the appropriate 123 FAIL alarm.

### Clock Units

Although the two clock units are synchronized to 123, it is essential that loss of the 123 signal has only a minimal effect on the pulse timing. Intrinsic accuracy is therefore built-in by means of two transistor-maintained tuning-fork oscillators of frequency  $500 \text{ Hz} \pm 1 \text{ part in } 10^5$ .

The output of each 500 Hz oscillator is converted to a rectangular waveform by means of a trigger circuit and serves to drive the divider chain. The overall division ratio 5,000 : 1 is achieved using seven divider stages. Binary pairs of the steering diode type, having a built-in noise immunity of 1 volt on the input line are used at each stage.

The 1-second and 10-second pulses are each of 100 milliseconds duration and 200 milliseconds in advance of true time; both are obtained by means of AND gates connected

to different stages in the main divider chain. The pulse outputs are transferred to the monitor unit via Schmitt trigger circuits and the complete divider chain is synchronized by the first 123 pip once every ten seconds. The first pip was chosen for the synchronizing reference because of the greater complexity of a circuit able to select the third pip.

During the first 123 pip, a pulse from the reset pulse generator sets each binary stage such that the state of the divider chain as a whole corresponds to a clock time of 8.06 seconds (0.06 seconds is allowed for generation of the reset pulse). The division process continues under control of the 500 Hz oscillator and, after 1.74 seconds, a 10-second pulse is generated. After an interval of ten seconds between reset pulses, the divider chain state should once again correspond to 8.06 seconds, but if some other spurious state exists, the reset pulse causes the divider to assume immediately the 8.06 second state. In between 10-second pulses ten 1-second pulses are generated by a two-way AND gate. Their exact period, however, depends on the accuracy of the 500 Hz oscillator as synchronism is effected only once every ten seconds.

To derive reset-pulses, the 123 signal is passed through a simple limiter to prevent the peaks of the waveform during the announcement period exceeding the peaks of the 123 pips. The pips are then amplified and detected, speech immunity being obtained by means of a 1,000 Hz tuned circuit in the amplifier and an *RC* time-constant in the detector. The detector output, after some 50 complete cycles of the 1,000 Hz first 123 pip, is of sufficient magnitude to operate a monostable-pair, and the step function produced by this transition is differentiated and used to reset the clock divider-chain. The unstable state lasts for 7.0 seconds, and during this hold-over period the detector output is effectively isolated from the reset line, preventing the 2nd and 3rd pips, and the major part of the announcement period, from causing false resets. The 7.0 second hold-over time ensures that correct synchronization is resumed after a maximum interval of 20 seconds even if the clock fails to synchronize on the first pip, but does so on the second or third.

The clock-unit circuits are arranged so that no special setting-up procedures are required, and, provided that the 123 signal is present at the correct level, synchronization is effected automatically. Should the 123 supply fail, the clock units will continue to function and run-free under control of the 500-Hz tuning-fork oscillators. Time errors after a period of up to 24 hours should be less than 1 second. Restoration of 123 will automatically reset the clock units to true time provided that the accumulated error is not greater than 1 second. If the interruption of the 123 feed has been long enough for a much greater error to accumulate—a most unlikely occurrence and one which would certainly warrant special attention—synchronization may occur on the wrong “pip” when 123 is restored, but, this will be corrected during the next two ten-second periods. The main switching equipment, however, will display the error and will need to be reset.

### Monitor Unit

The circuits used for continuous monitoring of the 1-second and 10-second pulses are identical—with the exception of the pulse-stretcher time-constants.

The 10-second pulses from both clocks are fed into the pulse-comparator stage. Each pulse train is amplitude limited and split into two paths each having opposite polarity. The four outputs are cross-connected in opposite polarity pairs (Fig. 3), and the outputs are connected via an OR gate to an integrator having a time-constant of 20 milliseconds. If the pulses being compared are in step and of equal duration the identical positive and negative polarity pulses will cancel, and no signal will be present at the OR gate output. Should the pulses, however, be out of step by more than 20 milliseconds, a negative-going pulse will be generated during the non-overlap period and give rise to a SYNC FAIL alarm. Similarly, if a pulse from either clock is absent a SYNC FAIL alarm is given.

To provide automatic changeover in the event of a pulse failure from either clock, the pulse outputs from the limiters are also connected via emitter followers to the auto-change-over section of the monitor unit. This section contains the pulse stretchers and a bistable switch. The pulse-stretcher circuit is basically a capacitor charged via a low resistance (the forward characteristic of a diode) and discharged into a high resistance. The output-pulse length is therefore mainly

dependent on the discharge time-constant and is longer than, and largely independent of, the duration of the input pulse. The pulse stretcher thus maintains the previous pulse amplitude above a predetermined level for an interval just longer than 10 seconds. The output voltage, therefore, never falls below this level if the input pulses arrive regularly at 10-second intervals. If, however, the pulse input is interrupted, the pulse-stretcher output will fall below the datum within 20 seconds. The outputs from the pulse stretchers are connected via diodes to the two inputs of a bistable switch; this switch directs the pulses from either the A or B clock unit via a gate to the circuit of a mercury-wetted-contact relay. The

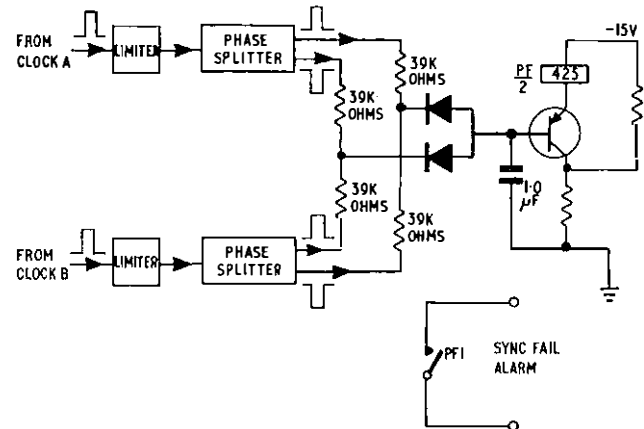

Fig. 3—Pulse comparator and SYNC FAIL circuit

electronic control of the bistable switch can be overridden by means of self-locking push-button switches LOCK ON A or LOCK ON B on the front panel. Under normal conditions with both clock units working, the mercury relay should be controlled by the A clock unit. If the pulses from the A clock unit should fail, the output from the A pulse-stretcher will fall below the datum and the pulses from the B clock will be switched to the mercury relay. Indicator lamps on the front panel show the state of the bistable switch. The local 123 supply is also monitored using an untuned audio amplifier and detector, to provide a 123 FAIL alarm should the 123 signal level fall by more than 10 dB.

### CONCLUSION

Four time-pulse generators have been installed since January 1968 in Network Switching Centres throughout the country. Initially, some difficulty was observed with the 123 synchronizing circuit, giving rise to false SYNC FAIL alarms. The original circuits have been modified and all four units are now giving satisfactory service.

### References

- 1 LLOYD, H. F., and SIXSMITH, J. A Television-Network Switching Equipment to 625-line Colour Standards *P.O.E.E.J.*, Vol. 60, pt. 3, Oct. 1967.
- 2 LANDER, A. C., and JOYCE, L. A. An Electronic Clock for Television Network Switching *P.O.E.E.J.*, Vol. 53 p., July 1960.

# Improving Underground Maintenance

## Part 2—Proving a New Organization

C. C. THAIN and D. R. WELLS†

U.D.C. 624.194.004.5

*The first part of this article discussed the investigation stage of a work study of local underground maintenance. This part describes the field trial conducted to see if the theoretical savings in costs and improvement in service can be achieved in practice.*

### INTRODUCTION

The investigation<sup>1</sup> stage of a work study of local underground maintenance showed that out-of-service time and costs of underground plant failures could be reduced if the Repair Service Control (R.S.C.) assumed responsibility for all underground faults that can be cleared by a solo faultsman working alone, or with occasional assistance. Whilst it was theoretically possible for one man to deal with simple subscribers' apparatus, overhead, and underground faults, it was considered more practical to divide the faulting work between two types of faultsman who had overlapping duties. For the purposes of the field trial these faultsman were called primary faultsman and external faultsman. A field trial of the practical solution began in the Bristol Telephone Area in February 1967.

### AIMS OF THE FIELD TRIAL

The objectives of the field trial were to:

- (a) reduce underground maintenance costs by employing solo faultsman instead of two-man maintenance jointer parties, wherever practicable,
- (b) reduce out-of-service time of circuits affected by underground plant failures, by reducing the number of men handling a fault before service is restored,
- (c) ascertain what work can be done by an external faultsman,
- (d) establish standard faulting techniques for external faultsman,
- (e) standardize the vehicle, tools, and stores used by external faultsman.

### ORGANIZATION OF THE FIELD TRIAL

The two new types of faultsman were introduced, working directly to a Report Control Officer (R.C.O.). The existing maintenance territories controlled by a supervising officer, were retained and staffed with sufficient primary and external faultsman to cope with the average number of common faults occurring. Staffing details for these territories when the trial had been fully introduced are shown in Fig 1. Before the trial was set up, each subscribers' apparatus and line maintenance man was responsible for clearing faults in a particular geographical area. This arrangement was retained as far as possible and these men took over responsibility for faults in cabinets and pillars, becoming primary faultsman. The external faultsman were also given territorial responsibilities, but dealt with faults in nearby areas as the number of faults

BRISTOL REPAIR SERVICE CONTROL AREA						
MAINTENANCE TERRITORY	1	2	3	4	5	TOTALS
PRIMARY FAULTSMAN	11	13	9	11	15	59
EXTERNAL FAULTSMAN	3	4	2	2	1	12
TWO MAN MAINTENANCE JOINTER PARTIES. SEE NOTE	—	—	—	—	—	16

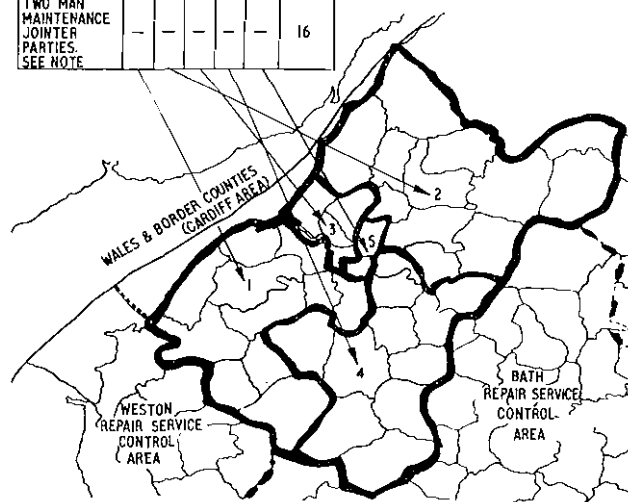

Note: Headquartered centrally, covering the whole R.S.C. Area.

FIG. 1—Area map showing maintenance territories in the Bristol R.S.C. Area, and the faultsman employed in them during the field trial

fluctuated. The differences in the work loads of the two types of faultsman resulted in each external faultsman's territory covering the territories of more than one primary faultsman.

Each R.C.O. also had a territorial responsibility and controlled a number of primary and external faultsman, whom he could direct in accordance with the needs of the work.

Primary faultsman were used as first choice by the R.C.O. for all fault clearance that he diagnosed as being within their range of duties, leaving the external faultsman to deal with faults diagnosed as cable faults. This arrangement clearly calls for an accurate diagnosis by the R.C.O. if faults are to be given to the man who is most likely to be able to restore service. Failure to do this means faults being unnecessarily handled by more than one faultsman, resulting in an increase in the out-of-service time and the obvious inefficient use of staff.

Work beyond the capabilities of the external faultsman was passed to maintenance jointer parties not controlled from the R.S.C. These parties normally comprise two men, having a bigger vehicle and who are better equipped to deal with, for example, cable renewals and manhole work.

† Major Projects Division, Management Services Department, Telecommunications Headquarters

## RESULTS

Progress during the trial was measured using standard area statistics, and a number of special returns designed to measure performance parameters not normally covered. The results were tabulated when the new organization had been operating for a year. The predicted changes in work practices, and the consequential improvements in costs and service were achieved in most cases as is shown by the following:

(a) 57 per cent of underground faults had service restored on the first visit. (Table 1),

**TABLE 1**  
Underground Faults Handled and Cleared by Various Parties Before and During the Field Trial

	Pre-Trial (Percentages)		Field Trial Period (Percentages)	
	Handled	Cleared	Handled	Cleared
Primary Faultsmen	100	nil	65	29
External Faultsmen	—	—	50	39
Maintenance Jointers (Note) .. ..	100	100	31	31
Other Parties .. ..	—	—	1	1
Total .. ..	200	100	147	100
Faults Handled Once	—	—	57	—
Faults Handled Twice	100	—	38	—
Faults Handled Three Times .. ..	—	—	5	—

Note. Two man parties not controlled by the R.S.C.

(b) 68 per cent (i.e. 29 + 39) of all underground faults were cleared by primary and external faultsmen either working alone or with occasional assistance (Table 1),

(c) the number of faultsmen was reduced by 9 per cent (Table 2) despite a 4 per cent growth in underground plant,

(d) the overtime of maintenance jointers was reduced,

(e) by using 15 cwt vehicles and by reducing the staff requiring vehicles, savings in vehicles costs were achieved,

(f) average out-of-service time due to underground plant defects was reduced from 47 hours to 32 hours. Fig. 2 shows

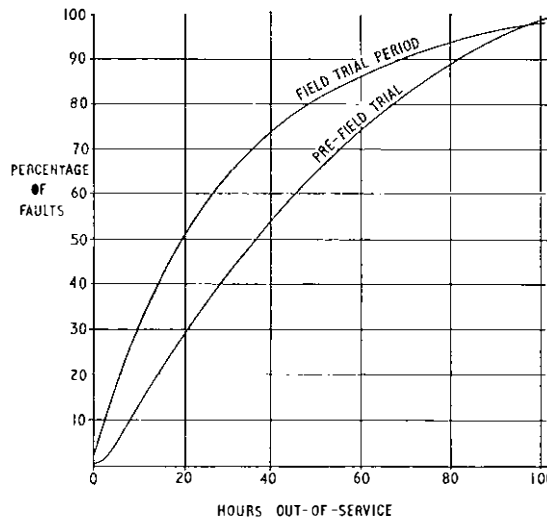

Fig. 2—Percentages of underground faults out of service for given duration

## THE EXTERNAL FAULTSMAN

A number of practical difficulties accompanied the introduction of external faultsmen. Among these were:

(a) disturbance to underground plant had to be minimized if its reliability was to be preserved. Therefore the practice of opening joints and cables for no other reason than to test, had to be minimized,

(b) repairs had to be carried out in a manner that reduced the need for further visits,

(c) a faultsmen working alone had to be able to carry out his duty independently of others, calling on supporting services only in difficult or unusual cases,

(d) means had to be found to permit one man to carry out tasks formerly performed by two men.

## IMPROVED TESTING AIDS AND METHODS

External faultsmen were equipped with a standard kit of tools and stores enabling them to deal with a range of common types of underground and overhead faults within the capability of one man. The initial provision of test equipment (Fig. 3) was generous, both in order to encourage faultsmen to

**TABLE 2**  
Staff Employed on External Maintenance Before and During the Field Trial

	Solo Faultsmen			Two-man Maintenance Jointing Parties Local Cables only (Men)	Total (Men)	Saving (Percentage)
	Subscribers and Line Apparatus Maintenance Men	Primary Faultsmen	External Faultsmen			
Pre-trial	66	—	—	30	96	—
During trial	—	59	12	16	87	9

how the restoration of service times are distributed to give an earlier fault clearance.

The reduction in total fault handling from 200 per cent to 147 per cent shows that R.C.O.s were reasonably accurate in fault diagnosis. This improvement in distributing faults was the main reason for the service improvement.

locate faults by conclusive testing from access points rather than by the much practised "halving" method, and to find out which were the most suitable instruments for this type of work. In the event, all items were retained and the complete kit stowed easily in a 15 cwt van.

The introduction of the Ohmmeter No. 18A,<sup>2</sup> giving a



FIG. 3—Test equipment carried by external faultsmen

direct reading of the resistance to a fault, has simplified the location of faults in local distribution cables. When used with a fault-locating slide rule,<sup>3</sup> which converts resistance to yards for the common sizes of cables met in the distribution network, faults can be quickly and accurately located (Fig. 4).

A test formerly requiring two men is the overground tone test for locating earth faults in directly-buried polythene cables. A locally-made experimental probe (Fig. 5) allows the test to be carried out by one man.

External faultsmen were encouraged during the trial to

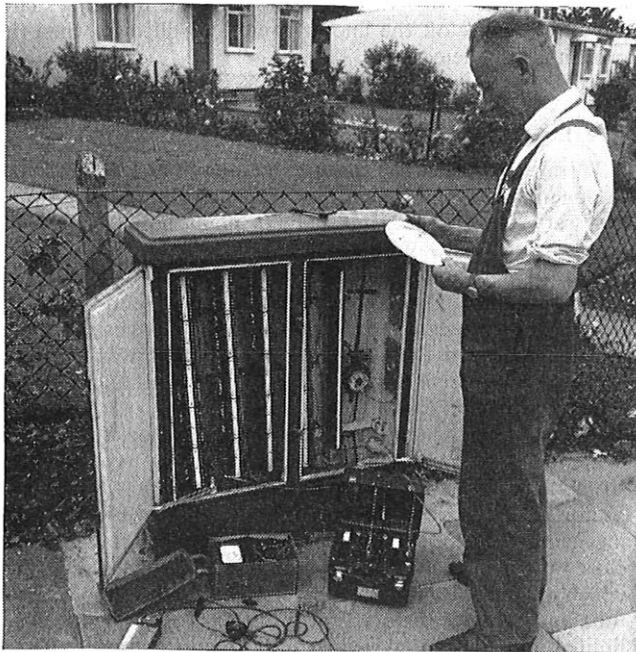

FIG. 4—Using Ohmmeter No. 18A and fault-locating slide-rule

confirm the result of one test by making another type of test where possible, to reduce the possibility of plant being disturbed in error.

Prior to the field trial, maintenance jointers made frequent calls to the routing and records duty for information. By issuing external faultsmen with cabinet and pillar address records and by using an oscillator and amplifier, circuits can be traced through cables and flexibility points without a pre-



FIG. 5—The overground earth test using an experimental probe

knowledge of the routing. In this way, the faultsmen is given a greater degree of independence, and telephone calls to the routing and records duty have been almost eliminated.

Standard work procedures were devised to enable one man to carry out work safely which, prior to the field trial, was done by two men (the changing of a block terminal and tail cable with minimum interruption to service is an example of this). However, there are occasions when it is necessary for a faultsmen on site to receive assistance to clear a fault, or he may need to pass the fault to a maintenance jointing party. It was found difficult and undesirable to lay down precise limits, other than those of safety, for the work to be undertaken by one man, or when assistance should be given instead of passing work to a two man maintenance jointing party. During the trial many of these decisions have been successfully left to the judgement of the faultsmen and R.C.O.s concerned.

If maintenance performance is to be improved, the fault rate, in terms of faults per circuit per annum, must be reduced. To this end, methods of repairs made by external faultsmen must not downgrade the standard of underground plant. A resin-filled joint was developed, for use on small diameter polythene cables, so that repairs to some obsolete joints can be made that improve the standard of the plant.

## CONCLUSION

The application of work study techniques to local underground maintenance has shown that considerable savings in costs can be made, and the customers service improved at the same time. Since the field trial at Bristol, the first stage of a new underground maintenance organization has been accepted for national adoption. Work is continuing on this project.

## ACKNOWLEDGEMENTS

Thanks are due to the management and staff of the Bristol Telephone Area, without whose wholehearted co-operation this experiment would not have been possible. The help given by the South Western Regional Headquarters and Telecommunications Headquarters Departments is also acknowledged.

## References

- 1 THAIN, C. C., and WELLS, D. R. Improving Underground Maintenance, Part 1—The Investigation. *P.O.E.E.J.*, Vol. 62, p. 222, Jan. 1970
- 2 CROSBY, G. W. A test instrument with a direct reading fault bridge—Ohmmeter No. 18A. *P.O.E.E.J.*, Vol. 60, p. 285, Jan. 1968.

# The London Cable-Tube System\*

W. H. LAMB†

U.D.C. 621.315.23

*An extensive network of deep-level tubes has been constructed under London solely to accommodate telecommunication cables. This article describes the methods of construction employed, some of the problems encountered and the equipment that has been devised to install a large cable network 100 ft below the ground.*

## INTRODUCTION

In the inner London area, the sheer size and quantity of the pipes, cables, sewers, drains, subways and the like installed under the roads often make it impossible for the Post Office to construct main duct lines at anything like reasonable depths. In consequence, duct lines in London have become deeper and deeper, and 40-way to 60-way lines 15–30 ft deep are now commonplace. Construction of these, and the subsequent cabling and jointing work in the very deep manholes, inevitably obstruct traffic, and the diversions and delays resulting are only too well known.

During the last war, a deep-level cable tube approximately 1 mile in length was constructed to protect certain essential cables. The experience gained showed that this type of construction could solve many of the external-plant engineer's problems in large cities.

Extensive use is now made of deep-level cable tubes in London, both as planned routes for trunk and junction cables and as a means of negotiating large natural and man-made obstructions.

## HISTORY

For many years the Post Office has installed cables on a rental basis in publicly-owned subways; notable examples are those under Kingsway and the Victoria Embankment. All contain the pipes and cables of gas, water and electricity authorities, and, despite supporting, protection, maintenance and management problems, they are, on the whole, satisfactory.

The first tunnel or tube solely for Post Office cables was constructed in 1925 between Gresham Street and London Wall. It is 6 ft in diameter, 630 yd in length with an average depth of 50 ft. No further tubes were constructed until 1942, when Faraday Building and Holborn telephone exchange were connected with a 7 ft diameter tube, 1,690 yd in length, at an average depth of 100 ft. Since 1948 the network has been progressively extended and it now totals 12 miles, with a capacity of approximately 1,800 miles of cable, of which some 800 miles have been installed.

## PLANNING

In London, cable tubes are considered as an alternative to ducts if the number of cables forecast for a route is 50 or more, if ducts would have to be laid under busy main roads at excessive depths, if large natural or man-made obstructions have to be negotiated or if road works would entail large-scale diversion of Post Office plant.

Surveys are made as for duct routes, but are of necessity more detailed. The principal factors that have to be considered are the choice of route, connexions to buildings and surface ducts, the location of loading and other chambers, and the availability of working sites.

Tubes are constructed under the Telegraph Acts, and, unless private way-leaves can be obtained, despite their depth, they have to be constructed under public highways. This sometimes presents acute design problems, and, consequently, some indifferent layouts have had to be accepted. In the opinion of the writer there is a very good case for the Post Office to seek powers to construct cable tubes in more or less straight lines under both public and private property.

Once the route is chosen, sites for shafts to connect the tube with buildings or surface ducts are determined and the location of loading and other tube chambers decided.

Working sites of the order of 15,000–20,000 ft<sup>2</sup> are necessary, and ideally these should be at the sites of shafts required for the project. If this is not possible, working shafts have to be sunk off the line of route and filled in when the project is completed.

## CIVIL ENGINEERING

Tubes are constructed at a nominal depth of 100 ft through the main strata of London clay. Even at this depth, care is necessary to avoid other undertakers' plant, notably London's Underground railway.

Until 1969, construction followed traditional civil engineering practice. Tubes were mined manually and lined with bolted cast-iron segments. Segment flanges were caulked, and the void between the segments and the clay was pressure-grouted. A concrete floor with drainage gullies and a granolithic wearing surface was then added.

During 1969 a new tube between Trafalgar Square and Waterloo was commenced, using the same type of construction as that employed by London Transport for its new Victoria Underground Line. This tube is being mined mechanically. A circular hole is cut through the clay to a very close tolerance and then lined with precast concrete segments, which are jacked into position. This produces a smooth-bore tube and obviates the need for grouting. Experience so far is limited, but substantial savings in both cost and construction time are expected. Fig. 1 shows a short length of this type of tube which has been constructed above ground for loading trials of fixing devices and cable bearers.

As far as possible, tubes are constructed in straight lines, but curves with a radius of 120 ft are satisfactory. Curves having a smaller radius can and have been constructed, but these handicap and delay cabling work. Normal gradients are of the order of 1 in 100. Steeper gradients can be accepted for distances up to about 100 yd but, as with curves, steep gradients for long distances delay cabling work.

† London Telecommunications Region.

\* A shortened and revised version of a Paper read at the London and other Centres during the 1967–68 Session.





FIG. 1—Concrete tube constructed above ground for loading trials

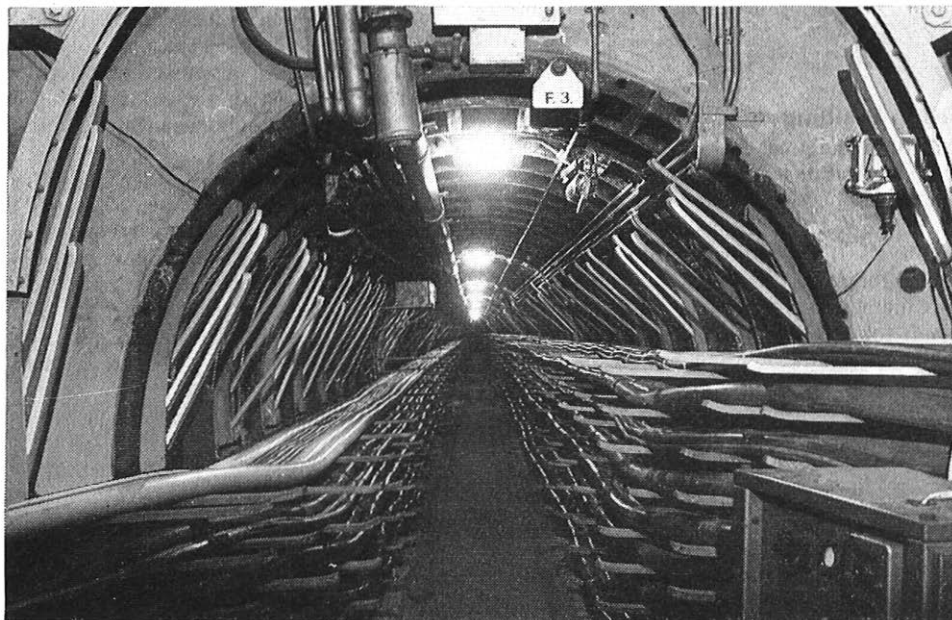

FIG. 2—Typical 7 ft diameter cable tube approximately half-filled

### TUBE STRUCTURE

The 7 ft diameter tube is the accepted standard (Fig. 2). It will accept 176 full-size cables but, to allow for variations in cable layouts, a capacity of 150 is used for planning purposes. This capacity is adequate for most routes and excessive for some, but 7 ft is the smallest diameter tube in which a 6 ft 6 in  $\times$  2 ft 3 in clear walkway for the movement of staff and materials can be provided. Tubes of a larger diameter are provided for ancillary structures.

### Loading Chambers

Chambers to accommodate orthodox-type loading pots are 19 ft 6 in in diameter and are constructed in line with the 7 ft diameter cable tubes (Fig. 3). Pots are installed along the centre, two rows on, and two below, a steel floor. The siting of loading chambers is critical. The absence of a common point in the tube network from which loading distances can be measured is a serious disadvantage. On a duct line, loading

spacing determines the position of loading manholes and these can usually be built within the specified tolerance. In a cable-tube network the position of the loading chamber determines the loading spacing. In consequence many loaded cables have to be provided with capacitor as well as loading pots. This complicates cable jointing, but the chambers are designed to accommodate both loading and capacitor pots as well as the additional joints.

### Flexibility Chambers

To provide a degree of flexibility in the junction network, some cables are terminated on distribution frames underground and circuits cross-connected by jumpering. The chambers consist of 19 ft 6 in diameter tubes 50 ft long with a floor on a horizontal axis.

Two dwarf frames with a total terminating capacity of 80,000 pairs are mounted on the upper floor, terminating joints being mounted on the lower floor.

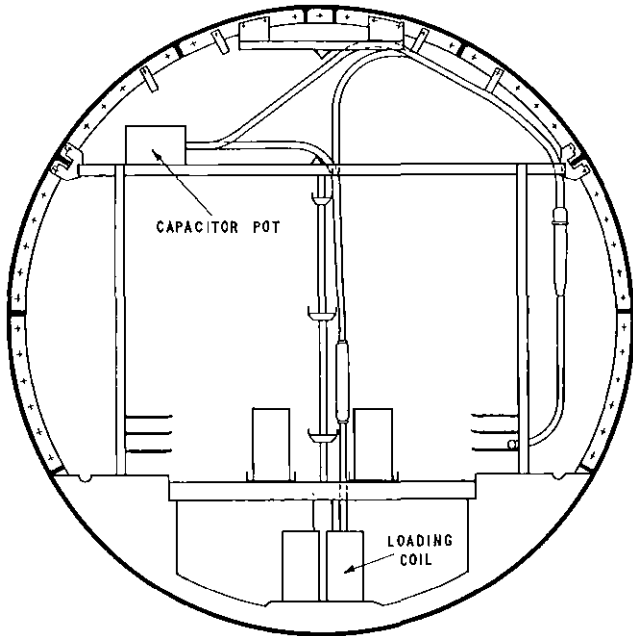

FIG. 3—Section through 19 ft 6 in diameter loading-coil chamber

### Connecting Tubes to Buildings

Tubes are connected to buildings by vertical shafts that accommodate telecommunications cables, water and sewage pipes, electric power cables, access ladders and lifts. Ideally, 4-ton lifts that can accept a 7 ft 6 in drum should be provided at  $\frac{3}{4}$ -mile to 1-mile intervals. If the number of cables terminating in a building is of the order of 50, cables and lift are installed in one 15 ft diameter shaft. For larger numbers of cables a separate shaft for the lift is desirable. Cable shafts should, if possible, terminate in the building, but lift shafts can terminate inside or outside buildings as convenient. All shafts

entering buildings are isolated with a brick or concrete wall, which is fitted with pipes and gas-tight glands for cables, and a gas-tight door for access.

### Connecting Tubes to Duct Lines

When it is necessary to connect a cable tube to a duct line, a large 2-room manhole is constructed at the surface. Duct lines enter one room and a vertical shaft connecting with the cable tube enters the second. Each room is provided with an orthodox manhole frame and cover and they are separated by an 18 in concrete wall fitted with a gas-tight door for access and pipes with gas-tight glands for cables.

As these manholes and shafts are constructed under highways, the shafts are not equipped with lifts (Fig. 4).

### CABLE SUPPORTS

A good cable-supporting structure is probably the most important single factor affecting the efficient use of a cable-tube system. All cable supports have to be fixed to the tube structure, and 1 mile of 7 ft diameter cast-iron tube, with its associated shafts and chambers, requires cable supports weighing approximately 360 tons and some 25,000 separate fixings.

In the early tubes, cable supports were fixed to segment flanges with long bolts (Fig. 5), but this method has been abandoned as it wastes space.

Tubes are now constructed with segments having cut-away horizontal flanges that enable cable supports to be fitted into the belly of tube segments in space which would otherwise be unusable (Fig. 6).

Cable supports consist of two mild-steel flats rolled to the same radius as the tube segments and fixed together with round pins that also support the cantilevers. These are also mild-steel flats, which are simply pushed-in between two pins. Mountings are adjustable to correct "roll" in the tube and to produce a 2° tilt on the cantilevers.

A large measure of standardization has been effected, and standard cable-bearer units are available for tubes of all diameters.

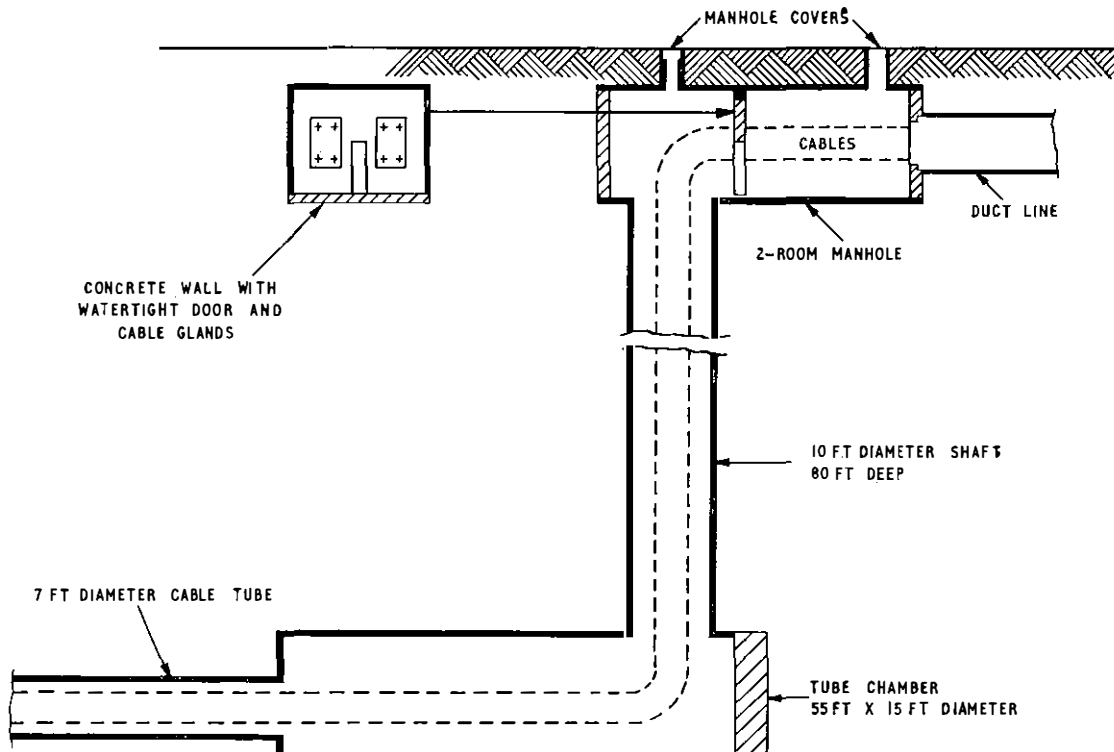

FIG. 4—Method of connecting tube to duct line.

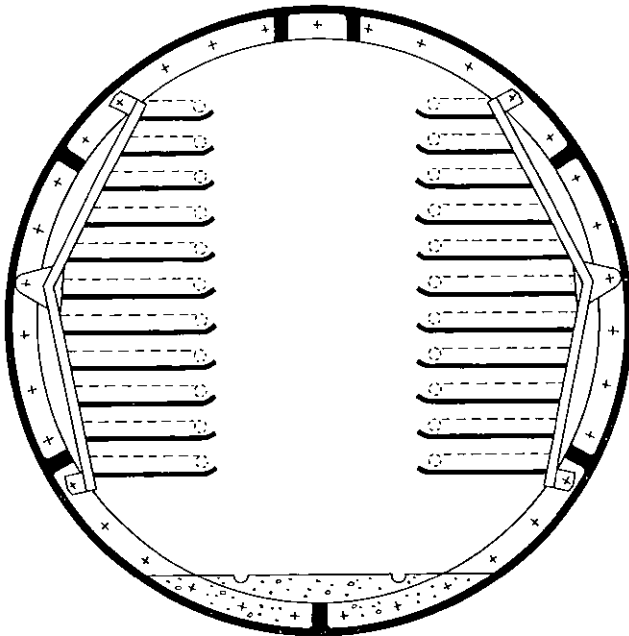

FIG. 5—Old-type cable bearers: capacity 134 cables

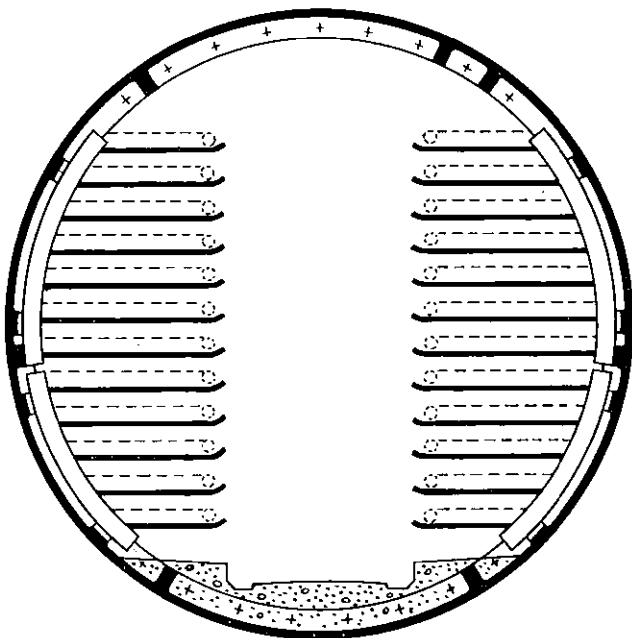

FIG. 6—New-type cable bearers: capacity 176 cables

In shafts, cables are supported on conventional lead-served mild-steel tacking bars at 5 in horizontal and 5 ft vertical spacing. Cable supports, platforms, ladders, lift guides, etc., required in shafts are designed as a whole and fixed to the shaft structure with long bolts through the segment flanges.

Supports in shafts were originally designed to accept lead-sheathed cables which are fixed with simple lead tacks. The same structure accepts polythene-sheathed cables, which are fixed with epoxy-resin putty tacks.

#### Finish

Cable-supporting steelwork in the first tubes constructed was either painted or galvanized, and extensive rusting occurred. The cost of derusting and repainting cable

supports in tubes is prohibitive, and the finish now specified is as follows:

- (a) shot blasting, degreasing, water washing, drying,
- (b) hot-dip galvanizing to a minimum thickness of 0.003 in,
- (c) etching with a chromate primer to provide a key for paint, and
- (d) two coats of synthetic air-drying enamel.

Nuts, bolts, washers, studs, etc., are zinc plated to a thickness of 0.001 in with one coat of enamel, brushed on after fixing. This finish has proved excellent. Initially it increased the cost of steelwork by 12–15 per cent, but as experience was gained this increase largely disappeared. The current (1970) overall cost of installing steelwork in cable tubes is £10 per cwt.

#### CABLING

Installing cables in tubes is somewhat more complicated than drawing them into ducts. Cable lengths have to be lowered 80–120 ft, either on or off drums, and then pulled up to  $\frac{3}{4}$  mile along the tube to where they are required.

If no lift is available, cables are lowered through 6 in diameter cabling pipes installed in shafts by means of a specially-designed cable-lowering machine. When a lift is installed cables are lowered on drums.

Pulling cable lengths along tubes presents problems all of which have not been completely solved. Cable may have to be pulled  $\frac{3}{4}$  mile along straight tubes having a gradient of 1 in 100, around curves with a radius of 120 ft, through tube chambers and, sometimes, around right-angle tube junctions.

Initially, this was done manually by mounting the cable on small 2-wheeled trolleys and towing with a gang of 10–12 men. Electrically-powered winches and capstans using  $\frac{3}{4}$  mile of steel-wire rope were then used. This latter method, although reasonably successful, was extremely dangerous and, after several near misses, was abandoned. Finally, a small battery-powered electric tractor was developed, and this has proved most successful. These small machines tow cable lengths weighing 3 tons at a speed of up to 3 miles/hr along the tube floor.

The tractors are used in conjunction with 2-wheeled cable trolleys which are placed on the cable at about 6 ft intervals. Trolleys are fitted with small guide-wheels which ride on the floor benching, thus allowing the tractor to pull cables around bends.

Cables are drawn around right-angle bends by means of quadrant roller-guides which are bolted to sockets in the tube floor.

#### JOINTING

Cable jointing is carried out by 2-man parties using orthodox methods. A special tube joint (Fig. 7), 5–6 ft long and with a diameter approximately  $\frac{1}{4}$  in larger than the cable, has been devised to save space. This is suitable for all types of lead and polythene cable in service and enables one additional cable to be placed on every bearer.

#### TUBE SERVICES

##### Lighting

Supplies are taken from the public mains and transformed down to 50 volts. General lighting is provided by 12 40-watt lanterns per 100 yd section, each section being separately switched. Socket-outlets for local lighting are provided at 24 yd intervals. No alternative or standby supply is provided.

##### Drainage

In general, the tubes are dry, but, despite caulking and grouting, minor leaks do occur in places. Water from these is drained by the floor gullies to sumps in tube chambers and pumped to the surface by automatic submersible pumps.

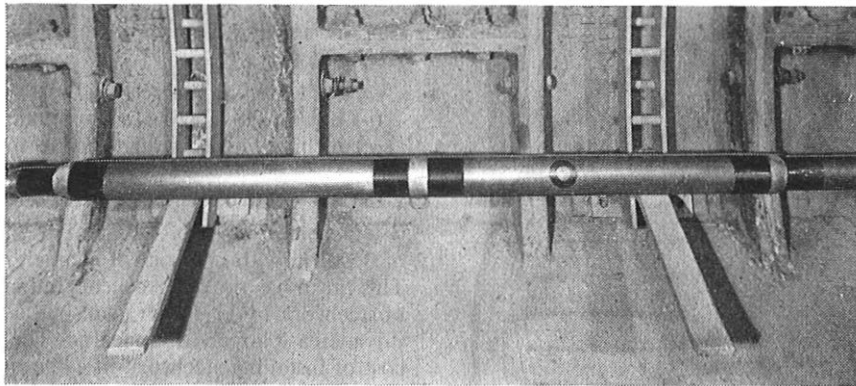

FIG. 7—Special joint used in cable tubes

### Ventilation

Forced-draught ventilation is used throughout. Air is taken from the surface, passed through the tubes and exhausted to the surface. Fans with an output of 2,500 ft<sup>3</sup>/min are installed at the top of selected shafts and these are supplemented when necessary by boosters installed in bulkheads and tube chambers. The average air flow is 1.5 ft<sup>3</sup>/s, and temperature is fairly constant at 58° F.

### Communications

For simplicity and reliability, communications are based on straightforward direct exchange lines. These are provided on a generous scale, at the top and base of all shafts, in lift cars and in all tube chambers. As far as possible, adjacent telephones are connected to different exchanges. Direct lines are provided where necessary for special purposes. In addition, two 200 lb/mile bare-copper wires mounted on bobbin insulators are installed in all main tubes to provide a local-speaker circuit for jointers and testers. Cables for tube telephones, alarm and miscellaneous circuits are clipped to a suspension wire mounted well above the main cable bearers.

### Marking and Signposting

As natural landmarks do not exist, artificial ones have been created. These consist of small enamelled-steel plates mounted every 100 yd on the tube fabric. By reference to these any location, e.g. the location of a cable joint, can be accurately described. Direction signs are installed at all tube junctions and other locations as necessary.

## MECHANICAL AIDS

A number of mechanical aids have been produced to facilitate work, mainly cabling operations.

### Cable-Lowering Machine

The cable-lowering machine consists of a series of cam-operated spring-loaded clamps that grip the cable as it enters the machine and release it as it leaves. It is operated manually by two men and enables cables to be lowered under complete control, without damage and with no intermediate support. It is used when no lift is available.

### Cabling Tractors

Cabling tractors are 4-wheeled, battery-powered, steerable tractors (Fig. 8) with a draw-bar pull of 1,000 lb. Their overall width is 18 in, and their speed is variable from 0–250 ft/min (3 mile/hr). The battery is 36 volts 256 Ah, which gives a range of operation under average conditions of approximately 8 hours. Batteries are recharged from rectifiers mounted in strategic tube chambers.

### Cabling Trolleys

A whole family of trolleys or skates has been devised. The latest (Fig. 9) consists of a 9 in V-section mounted on two 5 in diameter wheels surrounded by a spring-steel bumper on which are mounted four guide-wheels.



FIG. 8—Cabling tractor

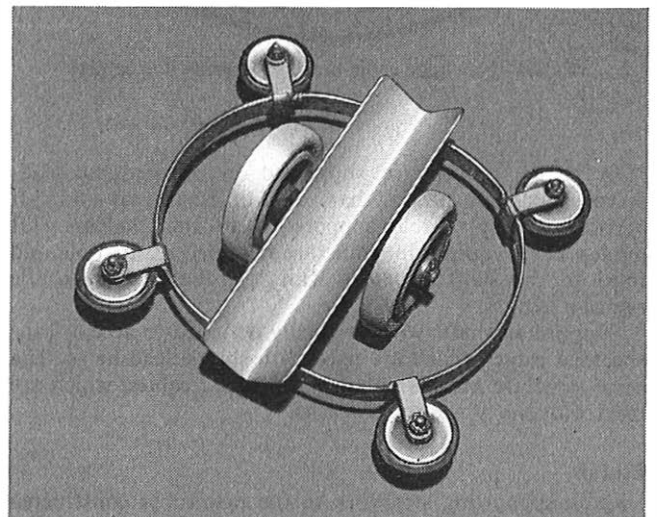

FIG. 9—Cabling trolley

### Quadrant Guides

Quadrant guides consist of grooved wooden rollers mounted on a steel frame to guide cables around quadrants of 5 ft radius. One is provided in each tube junction chamber and fixed, when required, to flush sockets in the chamber floor.

### MAINTENANCE AND MANAGEMENT

Maintenance effort is applied principally to installations and tube services; the structures themselves require little maintenance, although a few leaks have proved difficult to remedy. Cables similarly require little or no maintenance, and cable breakdowns are unknown. Strict control of cable routing is essential, and the position of all cables and joints is specified in detail before they are installed.

All tubes are patrolled daily and inspected periodically.

### EXTENSIONS AND RE-ARRANGEMENTS

Extension of existing tubes on the same general line is comparatively straightforward, and little re-arrangement of cables is usually necessary. Adding a new tube which joins an existing tube at right-angles is, however, a lengthy and expensive operation. The new tube is first mined up to the old tube and then a large chamber is constructed around the old tube. Cables are then suspended from the new chamber, the old tube smashed out, and the cables diverted to the new chamber.

### SAFETY

Cable tubes are not dangerous; in fact, work in them is far safer than in more orthodox underground structures. There is, however, a risk of fire and explosion arising from the need to use naked-flame appliances and flammable liquids, and in one short section of tube the air can become foul. A strict safety code is rigidly enforced, and safety equipment is provided on a generous scale.

Fire points consisting of a small CO<sub>2</sub> gas fire-extinguisher, sand trays and asbestos blankets are provided every 100 yd in the 7 ft diameter tubes, and these are supplemented by larger extinguishers and sand buckets in all tube chambers.

All members of working parties carry individual first-aid outfits, and cabinets containing emergency tools and equipment are installed at about ¼-mile intervals. The long distances and narrow walkways present a rescue problem, and, to meet this, air-sea rescue type stretchers mounted on light-wheeled trolleys are provided near the base of each lift shaft. Communication with the emergency services relies entirely on the "999" procedure. Close liaison is maintained with the London Fire Brigade and the London Ambulance Service, and their officers make regular visits to ensure that they are familiar with methods of access and routes. In addition, joint exercises with the London Fire Brigade are held annually to test the emergency procedure.

### Foul Air

An intractable foul-air problem exists in one short section of tube. Despite caulking and grouting, the tubes are by no means air-tight, and at times the air in this particular section can be deficient of oxygen.

The tubes generally pass through the main bed of London clay but the composition of this varies. The accepted theory is that some parts of this bed consist of porous sand containing a large reservoir of gas, rich in nitrogen and carbon dioxide, but with little oxygen. When there is a pressure differential between the air in the tube and the gas outside, air is sucked out or gas is blown in. Observations and tests partially confirm this theory; air passing out or gas coming in, is audible and the flow can be measured. These conditions are related to barometric pressure and, with normal ventilation the critical pressure is between 1,010 and 1,020 millibars. So far it has not been found practical to make the tube airtight, and an elaborate safety organization has been devised to safeguard staff.

### FUTURE DEVELOPMENTS

If the London junction cable network were to continue to be based on large audio cables there would be little doubt that cable tubes could be justified on an increased scale. The introduction of p.c.m. and, possibly, of other forms of multiplex working, however, make this doubtful. In general, it seems reasonable to assume that both the size and number of cables required for the junction network will decrease. If this is so, existing duct lines with some modest extensions may well suffice.

The physical and traffic dislocation problems of constructing and altering large duct lines under the busy roads of a large city remain. In the opinion of the writer there will, in the future, be an increasing need to construct isolated sections of deep-level cable tube, particularly in conjunction with road works, as the only practical means of routing cables past large complex obstructions. They may also be the only practical method of providing cable entry to large buildings. Multi-unit buildings present numerous duct-entry problems, and short deep-level tubes radiating from them and connected by shafts to surface duct routes may well be a solution.

### ACKNOWLEDGEMENTS

Acknowledgement is made to Sir W. Halcrow & Partners, Consulting Engineers to the Post Office, and to numerous engineering officers, both serving and retired, for much of the information and invaluable assistance in the preparation of this article.

### References

- <sup>1</sup> TURLEY, T. G. Cabling Problems in Subway and Tunnels I.P.O.E.E. Printed Paper No. 187, 1945.
- <sup>2</sup> Tunnelling in London Clay *The Engineer*, Vol. 211, p. 423 Mar. 1961.
- <sup>3</sup> WARD, W. C. Holes in the Ground I.P.O.E.E. Printed Paper No. 223, 1963.

# Measurements on Goonhilly 85ft Diameter Aerial

## Part 2—Profile Adjustment and Electrical Performance

B. A. LOWE, C.ENG., M.I.E.E., and H. E. PEARSON, B.SC.(ENG.), C.ENG., M.I.MECH.E.†

U.D.C. 621.396.67: 621.3.017.8

*Part 1 of this article described the mechanical methods used to assess the profile accuracy of the aerial paraboloid. Part 2 describes a method by which the electrical performance of the aerial may be determined using radio stars as reference sources, and the application of this method to improve the profile accuracy (and hence the electrical performance) by adjustment of the screw-jacks supporting the petals forming the paraboloidal surface.*

### INTRODUCTION

The overall transmission performance of a satellite communication system is largely determined by that of the satellite to earth-station path. The carrier-power radiated by a communication satellite is only a few watts and the free-space path loss between a geo-stationary satellite and an earth station some 200 dB at 4 GHz. The resulting flux-density at the surface of the earth is about  $10^{-16}$  watts per square metre. Even with an aerial presenting a frontal area of 500 m<sup>2</sup> (i.e. about 25 m diameter), the received carrier-power, between  $10^{-14}$  and  $10^{-13}$  watt, is less than the thermal agitation noise power that could be derived from a resistor at room temperature feeding a device having a bandwidth of about 25 MHz.

Therefore, to achieve an adequate carrier-to-noise ratio, large-aperture, low-noise aerials and extremely low-noise, first stage, amplifiers are required.

### AERIAL "FIGURE OF MERIT"

In a microwave radio relay system handling frequency-modulated (f.m.) frequency-division multiplex (f.d.m.) multi-channel telephony signals, the signal-to-noise ratio ( $s/n$ ) in a voice channel is directly proportional to the carrier-to-noise ratio ( $C/N$ ) of the signal presented to the f.m. demodulator (provided that the carrier-to-noise ratio in the intermediate frequency (i.f.) bandwidth preceding the limiter is greater than about 10 dB). Thus in any voice channel in the baseband:

$$\frac{s}{n} = \frac{C}{N} \times \frac{B}{b} \times \left(\frac{df}{f}\right)^2 \quad \dots \dots (1)$$

Where  $\frac{s}{n}$  = ratio of test-tone power to noise power in the voice channel,

$C$  = level of received carrier power in watts,

$N$  = level of total noise power in watts measured at the same point in the system as  $C$ ,

$B$  = bandwidth preceding limiter in demodulator (Hz),

$b$  = bandwidth of voice channel (Hz),

$df$  = r.m.s. test tone deviation (Hz),

and  $f$  = baseband carrier frequency of the channel under consideration (Hz).

Since, however,  $N = kTB$  where  $k$  is Boltzmann's constant =  $1.38 \times 10^{-23}$  Joules per degree Kelvin and  $T$  is the

effective noise-temperature of the receiving system in degrees Kelvin (K) and  $B$  has the meaning already ascribed to it, equation (1) can be arranged as follows:

$$\frac{s}{n} = \frac{C}{T} \times \frac{1}{kb} \times \left(\frac{df}{f}\right)^2 \quad \dots \dots (2)$$

It will be seen from this, that the worst signal-to-noise ratio will occur in the voice channel that occupies the highest portion of the baseband frequency-spectrum, and for this reason pre-emphasis is usually applied to enhance the deviation of the voice channels in the upper part of the baseband. At the same time, the deviations of voice channels in the lower frequency portion of the baseband are reduced below nominal so that the maximum deviation of the carrier, occurring during busy-hour traffic loading, is the same with or without pre-emphasis. Since in equation (2),  $df$ ,  $f$  and  $b$  are normally fixed, the parameter  $C/T$  has an important bearing on system performance. The received carrier power,  $C$ , varies directly as the aerial gain,  $G$ , while  $T$  also depends on the design of the aerial. Thus, the attainment of the required voice channel signal-to-noise ratio in a given system is directly dependent on the aerial-gain to system noise-temperature ratio ( $G/T$ ). This ratio is known as the receiving system figure-of-merit.

Therefore, the gain of an aerial can be increased or decreased without affecting the performance of the system provided that  $T$  is increased or decreased correspondingly.

### NOISE TEMPERATURE

The value of  $T$  for conventional receiving systems has generally been very close to the ambient temperature existing at the receiver—typically 290° K—but with the development of amplifiers<sup>1</sup> such as the maser, which can only operate at temperatures close to absolute zero (typically about 3° K) and parametric amplifiers which, though capable of operating at normal temperatures, can be operated with advantage at very low temperatures, the situation has changed.

However, though the first stage of the receiver may be operating at these very low temperatures, various other factors result in an effective temperature which can be much higher than the physical operating temperature. The effective noise temperature of the receiving system of the No. 1 aerial at Goonhilly, is about 65° K when the aerial is at an elevation of 30° to the horizontal. The main sources of the noise are losses in the primary feed at the focus of the paraboloid, the waveguide and waveguide components between the feed and the first-stage amplifier (35°-40° K), and the first-stage amplifier

† Mr. Lowe is in the Space Communications Systems Branch, and Mr. Pearson the Power and Ancillary Systems Development Branch, Telecommunications Development Department, Telecommunications Headquarters. Mr. Pearson was formerly in the Space Communications Systems Branch.

itself ( $10^{\circ}$ – $15^{\circ}$  K). The remaining ( $10^{\circ}$ – $15^{\circ}$  K) is made up of noise from that part of the sky at which the aerial is pointing, noise from the ground picked up via the side lobes of the radiation pattern of the aerial at 4 GHz, and spillover (i.e. ground noise picked up directly by the feed outside the periphery of the dish).

Thus, the system noise-temperature is a measure of the goodness of the receiver and aerial system as a whole and sets the limit to the smallest signal which can be resolved; coupled with the gain of the aerial, the received power flux-density corresponding to the minimum resolvable signal can be determined. System-noise temperature is similar to the noise-factor that denotes the limit of performance of a receiving system.

Though the figure-of-merit, rather than the aerial gain, is the more meaningful criterion by which the performance of a receiving system used for satellite communication should be assessed, only changes in gain (derived from G/T measurements) as a means of measuring the improvement in electrical performance resulting from mechanical adjustments to the aerial profile were considered. The reasons for this are:

(a) Day-to-day changes of system noise-temperature amounting to  $5^{\circ}$  K to  $7^{\circ}$  K and longer term variations of  $10^{\circ}$  K to  $12^{\circ}$  K have been experienced at Goonhilly. These variations could mask the sort of improvement it was hoped to achieve.

(b) For a high gain aerial, operated more than a few degrees above the horizon, those items already referred to as contributing to the system noise-temperature would not be affected by adjustments to the dish profile. The only exception to this would be contributions from the ground-facing side lobes and since these are inherently small with such an aerial no significant change in system noise-temperature was to be expected from this cause.

### AERIAL-GAIN MEASURING TECHNIQUES

For terrestrial line-of-sight microwave aerial measurements, use is made of a transmitter radiating a known power over an unobstructed path in the direction of the receiving aerial to be measured, but the size of the aerial systems used for satellite communications renders a similar technique difficult.

The basis of any gain measurement lies in the use of a reference signal, the level of which is known with a sufficient degree of accuracy throughout the period of the measurement. This requirement can be met by using the noise signal from a suitable radio star. When the aerial is pointing at a part of the sky containing a radio star, the system noise temperature will be greater than when looking at a part of the sky which does not contain such a star. The principle of the measurement is, that knowing the flux from the star which reaches the aerial—i.e. in effect the level of input signal to the device under test—the increase in system noise temperature produced by this flux can be calculated if the gain of the aerial is known. Conversely, the gain can be determined from a knowledge of the star flux and the increase in system noise temperature it produces. Hence, as the flux of certain radio stars is known with a high degree of accuracy, the gain measurement consists of measuring the increase in system noise temperature when the aerial is pointing at the star. The star thus acts as a signal generator.

The advantages of this are firstly that the elevation of the star as seen from the earth station varies, and so by the choice of a suitable radio star the performance of the aerial can be assessed over a wide range of elevation angles, and secondly, it is possible to choose a star which can be used by many earth stations, thereby eliminating one of the main variables in comparing the performance of different earth stations. Proposals recommending a standardization of the techniques of measurement and the choice of radio stars are being studied by an international committee.

### MEASUREMENT PROCEDURES

The procedure used at Goonhilly involves calculating<sup>2</sup> the aerial-gain from two measured noise ratios. The first ratio, the system ratio, compares the level of noise received when the aerial is pointing at the sky with a reference noise source, a load at ambient temperature. The second ratio, the star ratio, compares the level of sky noise with the noise received by the aerial when pointing at the star. These two ratios are measured at each elevation at which the aerial gain is to be determined. At Goonhilly, the star is tracked continuously for up to 12 hours during which the star elevation changes considerably. Throughout this period the two ratios are measured alternately; the time and elevation at which the measurements are made being noted so that a gain/elevation characteristic can be derived.

To obtain this characteristic, the track of the star is calculated by computer and a steering control tape produced which will enable the aerial to automatically track the star over the period concerned.<sup>3</sup>

Once tracking has commenced and the star located as precisely as possible, the aerial, while still tracking under tape control is moved away from the star, in azimuth only, by approximately one degree. The aerial is now following a course such that whilst its elevation is always that of the star, its azimuth always differs from that of the star by one degree (Fig. 1(a)).

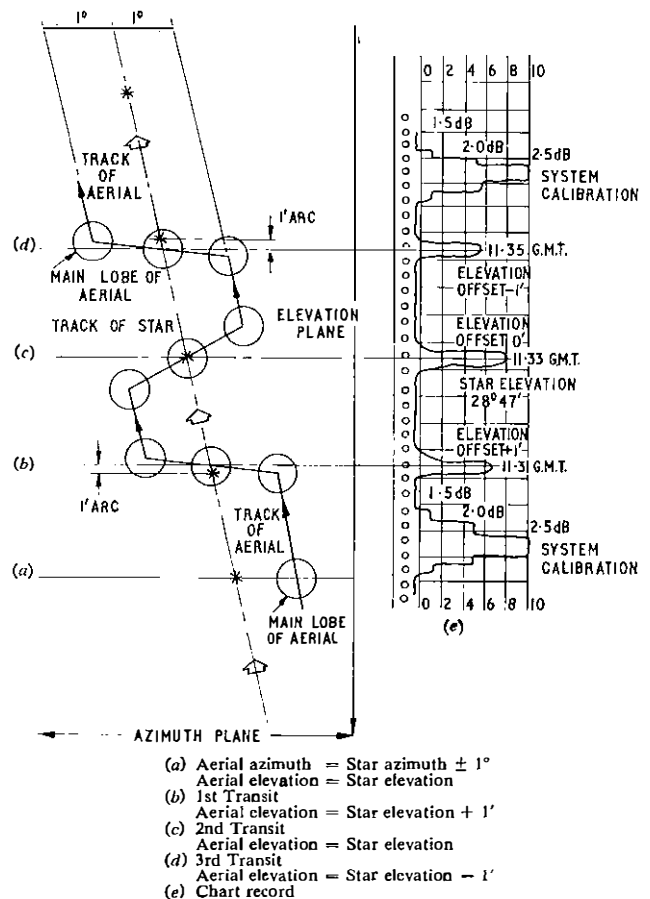

FIG. 1—Method of making transits with corresponding chart record

The aerial is then made to transit the star by gradually removing the one degree offset so that the aerial looks directly at the star and sees the noise radiated by it. It is then moved away from the star in the opposite direction until it is once more tracking with an elevation equal to that of the star and with an azimuth offset of one degree but on the opposite side to that of the original offset. The transit is made smoothly and

at approximately constant speed. Hence, assuming the original location of the star by the aerial to have been sufficiently precise, the sky noise picked up by the aerial before and throughout the transit will have been increased during the transit by the noise received from the star. The maximum increase (in dB) is the required star ratio.

However, it cannot be assumed that during the transit, the main lobe of the aerial will have pointed at the star with sufficient accuracy and it is therefore necessary to carry out at least three transits (Figs. 1(b), 1(c) and 1(d)). The first transit is made with the aerial offset from the nominal star-elevation by one minute of arc, the second with the aerial at the nominal star-elevation and the third with the elevation one minute of arc on the opposite side of the nominal star elevation from the first transit.

Frequently, the transits, or cuts, one minute of arc away from the nominal elevation will result in lower star ratios than the cut at the nominal elevation, indicating that during this transit the aerial pointed accurately at the star. If, however, the third transit results in a higher star-ratio indicating that the nominal elevation was not the correct one, then further cuts must be made until the ratio begins to decrease. The highest ratio measured during the three or more cuts is taken as the correct one.

The system ratio is obtained with the aerial one degree off the star by measuring the sky noise against an ambient load at a known temperature.

Thus the two ratios required for the calculation of aerial gain are obtained. In making the calculation, allowance may have to be made for the fact that if the angular size of the star is not small compared with the beam-width of the aerial, the star cannot be regarded as a point source, in which case not all the available flux will reach the aerial, and some of that which does reach the aerial will be on the skirts of the main lobe. For example, the radio star Cassiopeia A subtends an angle of about four minutes of arc at the surface of the earth, and this cannot be regarded as small compared to the 12 minutes of arc beam-width of the Goonhilly aerial. The correction for this can be up to 0.3 dB depending on the assumptions made. Conversely, Cygnus A consists of two point sources two minutes of arc apart requiring a correction of only 0.08 dB.

Allowance must also be made for atmospheric absorption particularly at low angles of elevation. The correction to be applied is proportional to the cosecant of the angle of elevation and at 4 GHz varies from 0.4 dB at an elevation of 5° to 0.05 dB at an elevation of 50°.

The signals picked up by the aerial whether from the sky, the star, or the ambient load are frequency changed to 70 MHz by the normal receiver chain and applied to a log/linear amplifier to drive a chart recorder. Precision attenuators in the chain enable the recorder to be calibrated in 0.5 dB steps and by spreading two of these steps over the eight-inch width of the chart, the actual ratio can be evaluated by interpolation to an accuracy approaching  $\pm 0.01$  dB. Fig. 1(e) illustrates the type of recording obtained and relates it to the star transits shown in other parts of the figure. The star ratio and system ratio are brought within the dynamic range of the chart recorder by the use of a second attenuator.

The use of the chart recorder in this way enables the ratios to be measured accurately and the transits to be easily observed so that the correct one can be selected for evaluation. Should the gain of the system vary during a measurement, that measurement can be discarded, and another made.

These techniques were first applied within the Post Office to the original Goonhilly aerial in 1962 using the radio star Cassiopeia A.

The decision to provide transatlantic telephone and television channels via the satellite EARLY BIRD on a commercial basis from the end of June 1965 necessitated extensive modifications to the profile of the bowl and an evaluation by mechanical and optical methods of the profile accuracy at

various elevations as described in Part I of this article. Further electrical measurements, again using the star Cassiopeia A, confirmed that changes in the shape of the bowl with changing elevation were having an adverse effect on the aerial gain. Fig. 2 shows the gain/elevation characteristic derived

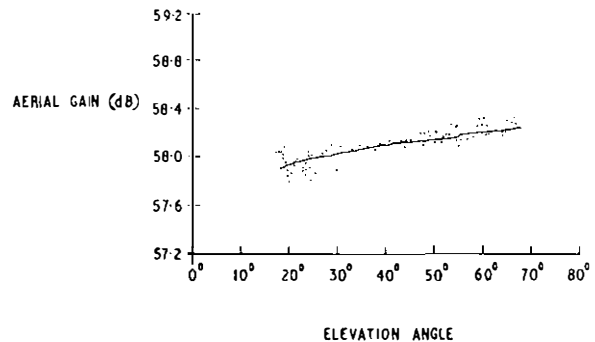

FIG. 2—Gain/elevation characteristic at 4.16 GHz—May 1965 and Feb. 1966—Cassiopeia A

from measurements made during May 1965 and February 1966; no significant changes in gain had occurred in the interval.

## PROFILE IMPROVEMENTS

An examination of the mechanical measurements taken during the final six months of 1965 suggested that by jack adjustment alone it should be possible to optimize the shape of the bowl at the EARLY BIRD elevation (approximately 30°) and so improve electrical performance at the working attitude. The first step was to adjust between six and ten of the jacks by about two-thirds of the amount thought necessary to correct fully for the departures from the true paraboloidal shape.

Since the improvement in electrical performance was expected to be only about 0.3 dB and there was no certainty that this would be fully realized, it was very desirable that complete sets of electrical measurements should be obtained immediately before and after making the mechanical adjustments. It was also very desirable that both the before and the after measurements should be repeated on two separate days to determine whether or not lack of repeatability of measurement was likely to mask changes due to the profile adjustments.

Previous aerial measurements using cosmic sources had utilized the star Cassiopeia A because it is a strong radio source and has the advantage of being circumpolar (i.e. always above the horizon at the place of observation) and therefore available for measurements at all times. This would not be the case with a star which set. The range of elevations over which Cassiopeia A can be seen from Goonhilly is 18° to 82°. Since aerial performance at elevations below this were of interest on this occasion, it was decided to use the circumpolar star Cygnus A, which, though not such a strong radio source, has a minimum elevation from Goonhilly of less than 0.5° and a maximum elevation of 82°. It had been tracked for short periods on several occasions to assess its suitability. Also, a limited number of measurements using Cassiopeia A were planned to permit comparison with previous results. A test program was therefore drawn up which allowed each of these stars to be tracked over a useful range of elevations within the period of one day. The range for Cygnus A was 10° to 50° and for Cassiopeia A from 20° to 40°.

The program was followed on each of the two days before adjustment and on each of the two days after adjustment. In all, approximately 200 gain measurements using Cygnus A and approximately 70 using Cassiopeia A were made.



The process of carrying out the mechanical adjustments went so smoothly that a total of 14 jacks was adjusted instead of 10 as originally intended.

The results from the before and after measurements are shown in Fig. 3 and indicate an improvement in gain of about

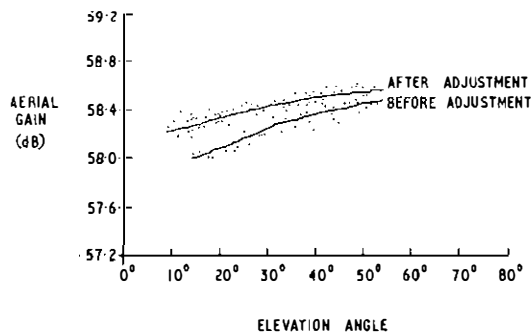

FIG. 3—Gain/elevation characteristic at 4.16 GHz before and after adjustment—Cygnus A

0.3 dB at the lower elevations and about 0.1 dB at 50°. The improvement at the EARLY BIRD elevation was about 0.2 dB. The Cassiopeia A measurements indicated an improvement of about 0.25 dB at the EARLY BIRD elevation.

Further measurements in October 1966 and March 1967 using Cygnus A showed good agreement with those measured immediately after the adjustment of the 14 jacks. The upper curve of Fig. 4 shows measurements made in March 1967 using Cassiopeia A and indicates that the measurements with the two stars are in reasonable agreement. The lower curve of Fig. 4 is a repeat of the curve shown in Fig. 2. The two

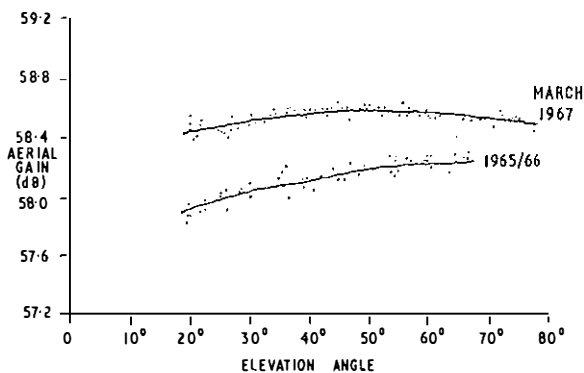

FIG. 4—Gain/elevation characteristic—1965/66 and March 1967—Cassiopeia A

curves demonstrate the overall improvement between 1965/66 and March 1967.

## RESULTS

The curve of gain versus elevation, Fig. 5, although a better shape after the adjustments than before, still shows greater gain at elevations above that of EARLY BIRD, indicating some remaining distortion at this elevation.

The shape of the gain/elevation characteristic also suggests that the estimates of the amount of adjustment required to correct the distortion were more accurate than had been supposed when deciding to take up no more than two thirds of the adjustment required.

For future uses of the aerial, maximum gain will be required at low elevation angles and if the profile were adjusted to

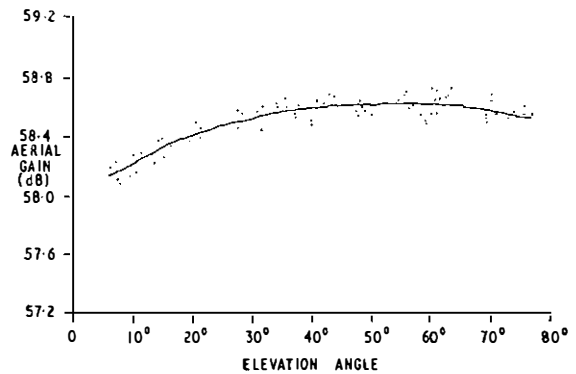

FIG. 5—Gain/elevation characteristics at 4.16 GHz 24/25/26 October 1966—Cygnus A

produce maximum gain at an elevation of 5°, up to 0.5 dB more gain could be obtained at the important low angles of elevation.

The improvement in aerial gain is small compared with the effort involved but this is acceptable for two reasons. Firstly, the performance of a satellite communication system is largely determined by the satellite-to-earth path, and with present systems this is limited by the power transmitted from the satellite. Consequently, in order to obtain the maximum number of circuits from the system, that system is operated very close to threshold, and any deterioration in the system could take the system below threshold. For this reason, even a small increase in margin is worth having because it will produce an equal improvement in the channel signal-to-noise ratios if the system is above threshold, and a greater improvement if the system is below threshold.

Secondly, with a costly item such as an 85 ft diameter aerial, it is sensible to obtain the best performance possible, since otherwise a given system performance would require a larger aerial. For an 85 ft diameter aerial, an improvement in gain of 0.3 dB is equivalent to an increase in diameter of about 3 ft.

## CONCLUSIONS

New techniques for the measurement of the electrical characteristics of the large steerable aeriels used for satellite communications have been described and the results of the successful application of these techniques to the No. 1. aerial at Goonhilly have been given.

In the process considerable experience in the use of the methods has been gained and improvements in technique made. This is well illustrated by the upper curve of Fig. 4 in which the scatter of the points is much less than on some of the earlier curves.

A list of references is given below as additional reading for those interested in the subject.

## ACKNOWLEDGEMENTS

Acknowledgements are due to colleagues in the Space Communications Systems Branch and the staff of Goonhilly Radio Station.

## References

- 1 DAGLISH, H. N. Low-Noise Solid-State Microwave Amplifiers. *P.O.E.E.J.*, Vol. 58, p. 11, April 1965.
- 2 RAVENSCROFT, I. A. Measured Performance of Modified Goonhilly No. 1 Aerial. *I.E.E. Conference Publication No. 21*, June 1966.
- 3 MARSHALL, J. E., and others. Digital Techniques used in the Steering Apparatus of the G.P.O. Steerable Aerial at Goonhilly Downs. *I.E.E. Conference Programme and Digest for International Conference on Satellite Communications*, 22–28 November 1962.

# The Long Lines Computer Project

B. CROSS, C.ENG., M.I.E.R.E., M.B.C.S.†

U.D.C. 681.31: 621.391

*The history of the Long Lines Computer Project is mentioned briefly and is followed by more detail of the feasibility and implementation stages. The system aims for the project are outlined and then re-introduced as a carefully staged implementation program. The description of Stage 1, due to be introduced to users in 1970, gives the facilities to be offered, discusses the record updating problems during the changeover to computer working and outlines the arrangements made to cover the possible failure of the computer. The article concludes that the project should be implemented as soon as possible but stresses the need to proceed carefully to ensure success.*

## INTRODUCTION

Prior to 1959, proposals had been made to convert the information on MU-cable diagrams to a form suitable for transferring to punched cards. When the London Electronic Agency for Pay and Statistics (LEAPS) computers were first installed, they were only lightly loaded and their possible use for circuit-provision work was considered. Therefore, during the period 1960-62, a program was produced for providing, ceasing and re-arranging public circuits on the LEAPS computers. The main lesson learned from this trial was that the sequentially-accessed LEAPS computer was not suitable for this type of work where fast access is needed to records in a random fashion.

Following the demonstration of the LEAPS trial, work on circuit provision as a whole was suspended until 1965, although some work in this general area was carried out on the Elliott 803 computer.<sup>1</sup> In April 1964, a small Post Office team visited four companies in the American Bell Telephone System. It was found that the Americans shared the Post Office view that direct-access storage was the logical medium for holding circuit-provision records and had made plans to use computers with such storage on magnetic discs. It became apparent from the visit that record conversion should commence as soon as possible to ensure that records are available to the computer when the programs are ready for use. Conversion of circuit and plant records to a form suitable for computer input is a major task, the current estimate for the United Kingdom work being between 150 and 200 man years.

A report, issued in December 1964, identified 14 separate work processes in a Telephone Area to which computer techniques could be applied. One of these processes was line-plant planning and control and, in January 1965, three groups were set up at national headquarters under engineering control to assess the feasibility of using computers for the following applications:

- (a) trunk and junction circuit planning, provision and utilization,
- (b) trunk and junction circuit estimating,
- (c) local line planning and provision.

The local line planning and provision study, although part of the overall line-plant control system and due eventually to form part of an integrated system together with the Long Lines Project, has developed separately and is not discussed in this article.

The first two studies, which have proceeded through the feasibility stage to implementation, now form the Long Lines Computer Project,

- (a) being known as the Long Lines Utilization Project, and
- (b) the Long Lines Forecasting Project.

The remainder of this article deals specifically with the progress and developments within the Long Lines Utilization Project.

## SYSTEM AIMS

The main aim of the utilization project is to accept the Annual Schedules of Circuit Estimates (ASCE), together with random demands for private circuit facilities, and process these to produce an output consisting of circuit orders for distribution to the field, plus the maintenance of a complete up-to-date record within the computer. Additional outputs will show the broad utilization for several years ahead. A large range of statistics should be available on demand and special programs can be added as required. Full information of line-plant usage, together with details of breakdowns and planned interruptions, should be held available for on-line display at Network Co-ordination Centres (NCC). The system should also be able to print out any necessary information in schedule form to assist these centres.

The input to the utilization project will mainly be provided by the output from the Forecasting Project (the ASCE). Initially, however, plans have been made to collect this information from manual records. Local-line information for private circuits will be obtained in the Area offices either by existing manual procedures or, later, from the Local Lines Computer Project. The request for junction, and possibly trunk, plant will be forwarded to the circuit provision controls (CPC) in the originating Area, who will obtain this information from the Long Lines Computer. Eventually, the Local Lines system will connect directly with Long Lines to avoid the need for intermediate manual handling. Many other projects are in the course of study, and integration with these may be required later.

## FEASIBILITY STUDY

The team to study "the feasibility of converting trunk and junction planning, provision and utilization to a computer system" was set up in January 1965 and the title was shortened to Long Lines Project some 12 to 18 months later. The basic organization of the team is set out in Fig. 1. A report was issued in March 1966 and, in April 1966, it was accepted from the technical viewpoint by both Headquarters branches and Regions at the Chief Regional Engineers' Conference of that

† Management Services Department, Telecommunications Headquarters.

year. The report recommended implementation of the computer scheme because of the benefits this would bring to the Post Office Telecommunications business. These benefits can be summarized as staff savings, plant savings and operational benefits.

The largest staff savings will result from computerization of the record maintenance and routine circuit-provision work of CPCs. However, the complicated circuit-provision work will still have to be dealt with manually for some time to come. It was estimated that 25 per cent of the staff in CPCs

of total plant assets. This has encouraged the Post Office to think that the original estimates are reasonable.

The third area of benefits is extremely difficult to quantify. It arises from the ability to give information to maintenance organizations so that breakdowns can be catered for by the utilization of standby facilities or other measures more quickly, thus improving the public service and minimizing loss of revenue. It will also be easier to control the complicated arrangements needed when planned interruptions to the network are necessary.

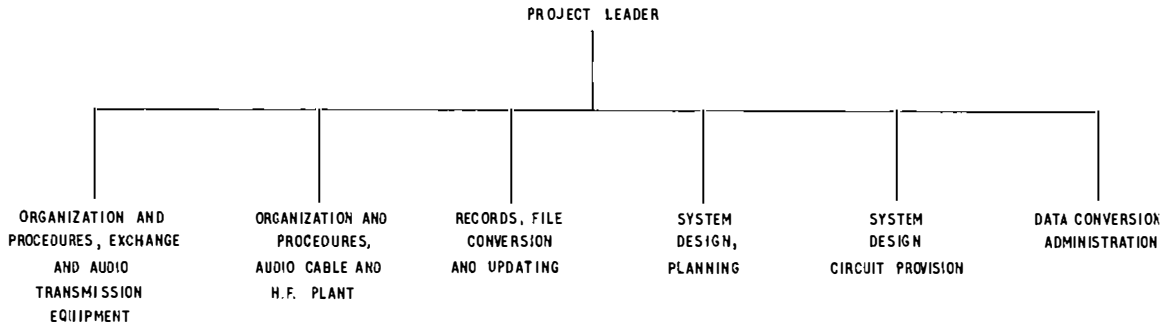

FIG. 1—Basic organization of feasibility study team

could be saved when the project was fully implemented. In addition, it was considered that the preparation of cable diagrams could be carried out by the computer using a digital plotting device, yielding a saving of 80 per cent of all drawing office staff engaged on this work. The total potential staff-saving forecast for 1970 was about 220.

The team also believed that substantial financial savings could be achieved from the ability of the computer to optimize plant utilization and plant planning. The original values given to these optimization savings were 5 and 3 per cent, respectively, although initially, there was no solid foundation for so exact a figure. Subsequently to the report being issued, figures have been received from an American company in the Bell Telephone System which show that, in an analogous situation, the savings achieved had amounted to 3.7 per cent

The total savings give a project return on capital of 94 per cent. Potentially therefore, it is a very profitable project which should be implemented as soon as possible to ensure the maximum benefit to the business.

The problems of allocating plant to meet current demands and accurately planning the relief needed to meet estimates of future requirements grow as the network expands and it is foreseeable that mechanization might be the only way of effectively controlling the network. Since computerization of any area of work becomes more difficult as the size of the records involved and the number of processes carried out increase, it is sensible to carry out the changeover to computer techniques as soon as possible.

Calculations have been made to establish the minimum level of savings at which the project return on capital is

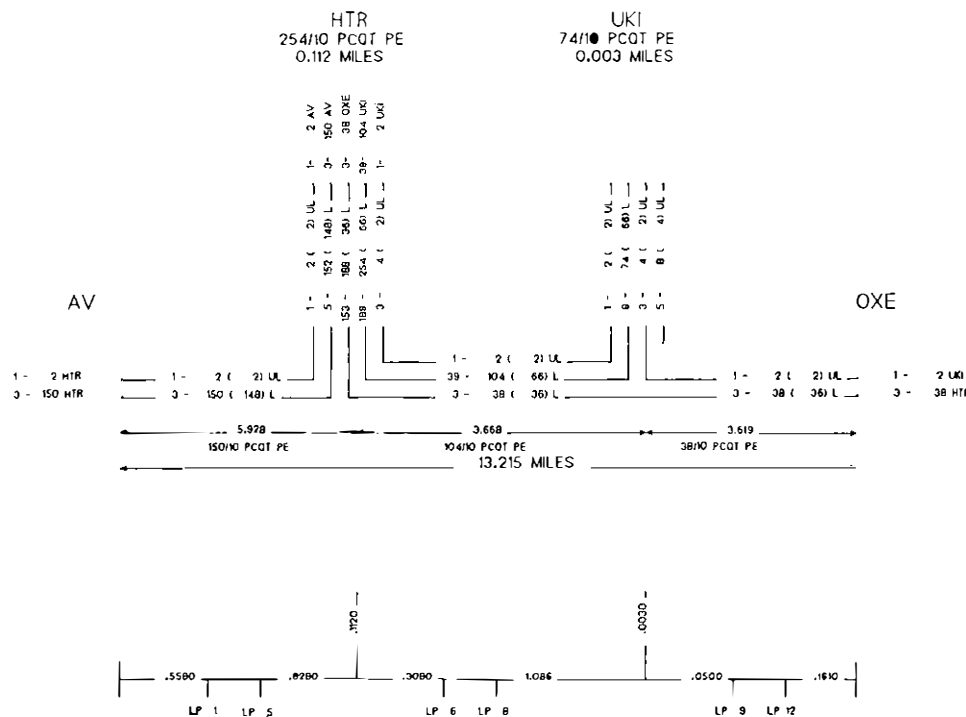

Note: Not shown full size

FIG. 2—Cable diagram drawn by computer-controlled digital plotter

SW/CJ 541

ANDOVER->OXENWOOD NO.1

RFS 1969

MU 4000 SHTS.71

maintained at the required Telecommunications Business target of 8½ per cent. It can be shown that, even if all savings only amount to one tenth of those estimated, it will still be profitable to continue with implementation.

Due to the need to make a careful assessment of Post Office resources for computer projects as a whole, to ensure that only projects of high priority are implemented in the first instance, coupled with the need to make further studies of the computer manufacturers' abilities to produce equipment and operating software suitable for the project, it was not until March 1968 that final approval was given to proceed with the implementation of the Long Lines Computer Project. For this project, an International Computers Ltd (ICL) System 4 Model 70 computer will be purchased by the National Data Processing Service (NDPS) and then rented to Telecommunications Headquarters (THQ) complete with computer room staff. Large disc files for direct-access storage and with full communications facilities for on-line interrogation and updating of records using visual display units (VDU) will be provided. Management Services Department (MSD) will be responsible for the system design and programming and overall implementation of the project.

From March 1966 until March 1968, most of the team were engaged on producing programs to give interim assistance to Headquarters branches and Regions in the general area of the study and also to test various procedures that would event-

Project and a third co-ordinates users' requirements for the Forecasting Project. Two other committees have also been established; the Long Lines Computer Co-ordination Committee which co-ordinates action between the Telecommunications Business, ICL and NDPS, and the Long Lines Computer Equipment Working Party which brings together MSD and NDPS to determine operational requirements for the computer centre.

Periodically, status reports are issued to give factual information on progress. So far, four status reports have been issued and the last one, published in March 1969, was distributed to Regions and Areas. In addition, personal contact has been maintained, and the project leader has visited every Region to give informal talks describing the computer facilities that will be available.

A documentation system has been set up for the Long Lines Computer Project and the circulation includes Regional representatives. One section of the documentation, the Users' Manual, will be issued to all offices equipped with VDUs. The manual will give full information concerning the use of the VDU and the facilities it offers. Fig. 4 shows a VDU of the type to be used. In addition to the Users' Manual, there will be administrative instructions issued by the operational departments concerned to inform users of the way in which the computer system will be used for day-to-day work.

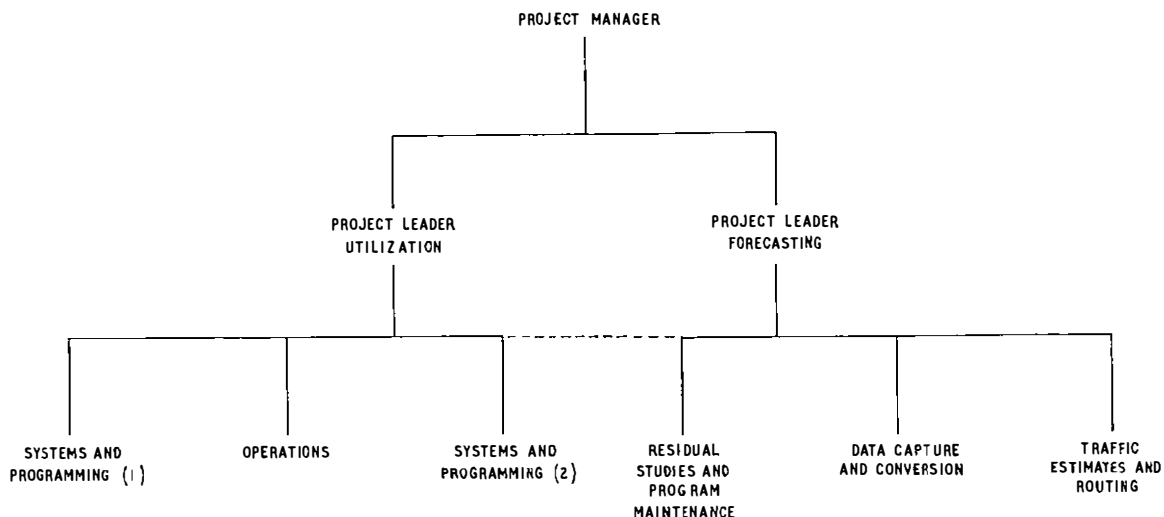

FIG. 3—Basic organization of implementation team

ually be needed for the main project implementation, such as automatic routing procedures and cable diagram plotting by computer. Fig. 2 is an example of a cable diagram drawn by equipment attached to the ICL 503 computer at THQ.

## IMPLEMENTATION

Although authorized from March 1968, the need to recruit and train personnel for the project teams delayed the establishment of the full implementation team until July of that year. Fig. 3 shows the organization of the implementation team for the Long Lines Computer Utilization Project and also includes the Forecasting Project since, as may be seen from the diagram, certain functions in the groups are common to the two sections. As it was considered vital that a project of this type should go forward step-by-step in accordance with the users' wishes and directions, they were all represented on the Long Lines Computer Technical Steering Group set up in 1967. To assist the technical steering group, technical working parties have been established to carry out particular functions. For example, one studies the methods of data collection for all line and exchange-equipment records, another co-ordinates users' requirements for the Utilization

## IMPLEMENTATION STAGES

The system aims are fairly simple and basic, but they cover a vast amount of processing, record handling and updating. Also needed are procedures for changing over from manual to computer systems. Although fully informed and consulted concerning the implementation of the project, staff in the Regions and Areas will be involved to a minimum in the early stages so that they are left free to continue with the current heavy commitments of day-to-day work.

A rapid changeover from a manual to a fully automated system can cause severe problems, since any project needs a considerable time for testing and parallel running to ensure the removal of errors. Even then, there will always remain the possibility that occasional errors will cause failure. The system must, therefore, include procedures to repair the damage and to resume operations as soon as possible. Initially however, when the manual system is operated in parallel with the computer, it would be wasteful to provide the computer standby facilities that will eventually be necessary.

The project must be carefully staged to ensure that the steps taken in implementation are not too large and that

users never have to rely too heavily on the computer for their operations without adequate standby facilities. Stages 1 and 2 cover the implementation of a record-keeping system. By the end of Stage 2, all records needed for the utilization and planning of trunk and junction plant will be held on the Long Lines Computer and regularly updated in step with changes in the offices concerned. Stage 1 covers the whole of the line-plant allocation record and the records for terminal-exchange equipment at group switching centres and higher order centres. Also included are the outstanding circuit-order records and a current circuit-order file for all circuits provided during Stage 1 and beyond.

Stage 2 will extend the records created in Stage 1, and will build up a complete set including all terminal-exchange equipment records, transmission-equipment records, circuit-order records for all current circuits and a traffic and engineering route record.

necessary to load these records from magnetic tape on to the large disc file coupled with those needed to print out these records from the disc. Also, and most important, programs will be written to copy a complete set of records from the disc to magnetic tape for security reasons, and reconstitute these records at any time.

The Stage 1(a) facilities will only be available to project staff except for the basic message switching system between VDUs which will be made available to all terminals as soon as they are fitted so that users can gain experience with them. The project team can then arrange the simultaneous working of all terminals to ascertain the handling capacity of the computer routine.

#### Stage 1(b)

Stage 1(b) consists of all the basic facilities needed by users to ensure that the records held on the computer may be

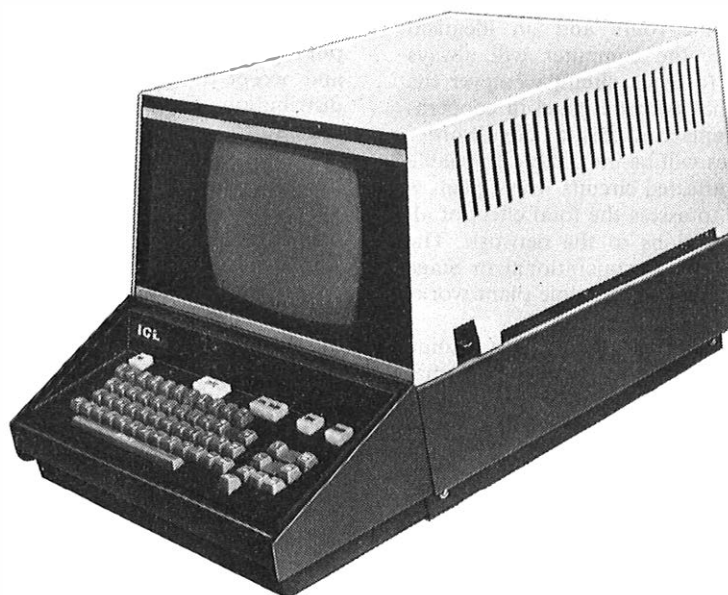

FIG. 4—The visual display unit used on the Long Lines Project

Stage 1 facilities should be completely tested and available by the end of 1970 and Stage 2 will be implemented one year later. Stage 3, intended for implementation in 1972-73, will cover introduction of the full facilities described under system aims. During Stages 1 and 2, standby will be given by the manual system but, before Stage 3 is commenced, a dual processor type of installation will be provided. With this type of system, reversion to manual operation may still be necessary if there is a catastrophic failure of the computer equipment, but this is so unlikely that user departments will be able to assume complete reliability.

#### STAGE 1 DETAILS

Stage 1, the only part of the project so far agreed with the user departments, has been split into three phases since it is necessary to arrange the work so that blocks of facilities and procedures can be completed and tested together.

##### Stage 1(a)

Stage 1(a) consists of the basic facilities required by the project team and it includes a real-time control-routine, capable of handling all the VDUs. This routine permits terminals to connect to, and disconnect from, the system, to interchange messages and also offers a small number of control facilities for project staff. The records which are to be placed on the large disc file will, in Stage 1(a), be maintained in a reasonably up-to-date condition on magnetic tape using well-tried procedures. Stage 1(a) will also include the programs

readily updated, on line, as transactions occur. One facility will be an inspection routine to enable users to inspect any part of the cable and high frequency supergroup and group records held on the computer. The major facility is given by the record-update system which enables circuit orders to be applied to the computer using a VDU. The computer will vet the order, checking that authentic codes have been used to describe exchange and repeater stations, that plant listed on the order is correct and that it is controlled by the office using the VDU. It is important that the computer should prevent one Area's records being amended by any other Area. Once a circuit order has been accepted as valid, the associated plant records will be updated to show the current status, and the order placed on the large disc in the appropriate file. Once or twice a day, this file will be scanned by the computer and circuit orders that have been placed on it will be printed on the lineprinter, which will be able to print a circuit order every one and a half seconds. This routine will also be able to accept earmarkings, these being tentative allocations of plant which cannot at present be booked against a circuit-order requirement. When the work on the circuit has been completed, a completion report will be fed back from the VDU at the controlling Area to the computer which checks that it is a valid outstanding circuit order. If so, the line-plant records will be updated with the final status, and the circuit order in the outstanding file will be tagged to show it is completed. During the twice-daily scan, such circuit orders will be removed from the outstanding file and, except for ceased

circuits, a condensed version placed on the current circuit-order file on magnetic tape. A circuit-completion advice will also be printed on the lineprinter for circulation to those concerned. These facilities will permit a basic record-keeping system to operate. Some additional features will be provided to meet more complicated situations.

### **Stage 1(c)**

Stage 1(c) is designed to complete the work left in 1(b). For example, the inspection routine will be extended to include the terminal-exchange equipment-record, a part of which will by then have been placed on the large disc. The routine will also be further modified to enable certain analyses of the information to be presented for the specialist requirements of the NCC who will not want to inspect every pertinent record held on the machine simply to discern which routes and circuits are affected by a breakdown. The update procedure will be further extended to enable, in certain circumstances, circuit-order inputs in multiples of two or more where all circuits are on the same traffic route and on identical engineering routings. However, the computer will always produce a single circuit order for each circuit whatever the input. The circuit-order form has been designed in cooperation with user departments to replace all existing circuit-order forms. Further detailed facilities will be introduced to enable an NCC to print schedules of affected circuits where plant is liable to interruption and also to assess the total effect of all planned and unplanned interruptions to the network. The cable-diagram drawing routine will be operational in Stage 1(c), together with a system to progress the line plant works program.

Stage 1(a) has been operational, apart from the disc-loading procedures, from August 1969 but it is not expected that Stage 1(b) will be completed until October 1970. All facilities for Stage 1 will be available by the end of 1970 with the completion of Stage 1(c).

### **THE CHANGEOVER TO COMPUTER WORKING**

Data conversion presents a very large problem; on the cable-allocation record alone, there are some three million entries. At present, the existing manual records cannot be read directly into the computer. It is, therefore, necessary to transcribe these records on to special conversion documents from which punched cards are produced. These will be readily accepted by the computer which checks the details for accuracy where possible. For example, the engineering codes used and the physical dimensions of the record will be vetted together with a check that alphabetical information is not recorded where there should be numerical digits and vice versa. When the computer has read the data and stored them on magnetic tape, it will also produce a printed report listing the errors. This report is returned to the data conversion unit for correction of the errors listed. These corrections, together with any changes that have occurred, are punched on to cards, read by the computer, checked and used to update the main master file. By this means, it is possible to obtain a correct record, on magnetic tape, of the cable-allocation records existing at a particular point in time. However, with this scheme, the records will be slightly out of date because of the time lag in effecting the changes. This is unlikely to be reduced below two weeks and it is necessary to use other means to obtain a more accurate record just before circuit-provision offices change over.

At present, duplicates of all MU and CJ records are held on magnetic tape. A proportion of these records has passed through one update cycle and this will be continued until all the records are being maintained no more than a month or two out of date.

The conversion of circuit-provision work to computer processing will be carried out one office at a time in the following manner. From a date to be arranged with each office, almost certainly a Monday, the staff will set aside a

copy of all circuit orders produced from that day forward, together with details of any changes made to that office's records not resulting from the issue of circuit orders. On the following Friday, the final update cycle of that office's cable-allocation records, held on a magnetic tape, will be commenced. As soon as this has been completed, the allocation records will be loaded on to the large disc file ready for on-line access. The VDU circuit-order input facility will be used by a data conversion team member to work gradually through the outstanding circuit orders and record changes until the work is being dealt with as it is being issued. At this stage, the complete cable-allocation record will be printed by the computer and posted to the office. Thereafter, each week, the computer will print fresh copies of all cable records changed during the preceding week. From the circuit orders applied to the computer input, printed orders will be returned in a day or two thus enabling the office to decide whether the computer is accurately accepting and printing them. If the output is acceptable, the next stage will be for the office staff to take over operation of the VDU. They will put the circuit orders into the computer directly in draft form, and accept the printed copies returned for duplication and distribution. The data conversion team member can then be released to assist in the conversion of another office.

By this time, the office using the computer system will be deciding whether the computer is maintaining the plant-allocation records accurately by reference to the weekly printed copies. If it is, the original manual records may be scrapped and the computer-produced records used instead. Manuscript entries can be made on these copies for a few weeks if necessary, so that the office will be able to ensure that all changes have been incorporated and printed when they receive the weekly updated print-out. The office will now be tied fairly closely to the computer process but will be able, at any time, to revert to full manual processing should this be necessary. Eventually, offices may decide not to make manuscript entries on their computer-printed cable-records but accept that these can be up to a week out of date. Instead, they can, by means of the inspection facility via the VDU, refer to the computer-held records which will always be completely up to date. The terminal-exchange equipment-records will also be held on the computer and may, by the end of Stage 1, be inspected and updated via the VDU.

The problems associated with the procedures necessary to recover from errors made by the computer are extremely complex and could easily occupy an article of this length in themselves. Suffice it to say that facilities are being designed in conjunction with the users and will be provided before any office has to rely on the computer system. When failures occur, the computer itself will be used, when possible, as a medium to notify users of the problem and advise when service will be resumed. To cover those cases when the computer has completely failed however, information about the breakdown will be provided by means of an answering machine connected to one of the fault-reporting lines at the computer centre. Any error which causes records to be overwritten or otherwise incorrectly amended, will be traced before the system is allowed to become fully operational again. The records held on the computer are copied daily and the copies held in safe locations. To reconstitute records, it will be necessary to reload one of these copies on to the disc files at the appropriate time and then to run through the daily log of work transacted by the computer. This is also recorded on magnetic tape, to bring the records up to date with the transactions effected up to the time of the breakdown.

### **CONCLUSIONS**

Already, several volumes of information have been prepared about the Long Lines Computer Project and any article covering the whole field of application can be no more than a summary. It is hoped that the general background of

the project and the reasons for implementation have been made clear. It should be emphasised that the implementation program has been carefully designed to take account of:

(a) the relative inexperience in the United Kingdom of this new field of computer operation, and

(b) the need to ensure that users are able to accept mechanization smoothly and easily at a time when circuit-provision work is at its highest level in the history of the Post Office.

## ACKNOWLEDGEMENTS

The contributions made by International Computers Ltd. and the National Data Processing Service to the work of this project are gratefully acknowledged.

## Reference

<sup>1</sup> CROSS, B. Using a Computer for Main-Line Planning and Circuit Provision. *P.O.E.E.J.* Vol. 58, p. 272, Jan. 1966.

# Jointing Coaxial Cables for Schools Closed-Circuit Television Networks

C. P. SELF†

U.D.C. 621.315.687.1: 621.315.212: 621.397.743

*The introduction of a solid-dielectric type of coaxial cable for the transmission of television programs to schools required the development of a new jointing technique. This article describes the technique and the jointing equipment which has been developed.*

## INTRODUCTION

A coaxial cable that could be installed in Post Office ducts alongside existing subscribers' cables was needed for the schools-television network.<sup>1</sup> A more robust cable than the standard 0.174 in or 0.375 in diameter coaxial cables was necessary, and a coaxial cable with a solid-polythene dielectric and a polythene outer sheath was chosen. This presented new problems, because the need to joint this type of cable had not previously occurred in the inland network.

The methods already in use for jointing trunk coaxial cables<sup>2</sup> could be applied to the conductors of the new cables, but a satisfactory method of restoring the solid dielectric over the centre-conductor joint was required. It is essential for the re-formed polythene to be visibly free of voids and to be bonded to the undisturbed dielectric in the cables on either side of the joint, to prevent the entry of water even after the cable is subjected to bending during cabling operations. In order to use the available skills of cable jointers and the special tools already in their possession, it was desirable for existing methods to be incorporated into the new technique wherever possible. A method based on submarine-cable practice was evolved, therefore, using a simple electrically-heated compression mould and polythene granules. The

power supply for the mould is taken from the 24-volt batteries used by jointers for lighting and brazing.

## SCHOOLS-TELEVISION CABLES

Three sizes of cable are used for schools-television networks. These cables have outer-conductor diameters of 0.620 in, 0.345 in, and 0.285 in respectively. The centre conductor is a solid-copper wire, and the solid-polythene dielectric is extruded over it. The outer conductor for each of the two larger cables is formed from a single copper tape shaped into a tube with longitudinally-welded seam. A polythene sheath is extruded over the outer conductor.

The 0.285 in cable has an outer conductor formed from two layers of copper-wire mesh. This form of construction makes the cable more flexible and particularly suitable for lead-in tails to buried amplifiers.

## COMPRESSION MOULD

The compression mould assembled across the jointing gap of a 0.620 in diameter coaxial cable, is shown in Fig. 1. It has a base of heat-insulating material on which the mould box, made from solid brass, is mounted centrally. The mould box consists of two matching halves, each of which has a rectangular-shaped cavity and an electrical heating element incorporated in the metal wall. Various shaped inserts,

† Mr. Self is in the South Eastern Telecommunications Region, but was formerly in the Civil and Mechanical Engineering Branch, Telecommunications Development Department, Telecommunications Headquarters.

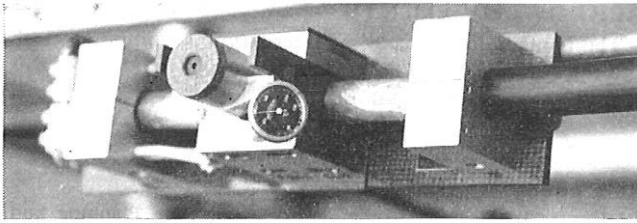

FIG. 1—Compression mould

depending on the shape and size of the moulded dielectric required, can be placed in the rectangular cavities, and when the two halves of the mould box are screwed together the mould-shape is almost completely formed. The shape is completed by the lower end of a compression plunger, appropriate to the insert being used, which is inserted into the top of the mould box. Because the outer conductor of 0.285 in cable is jointed by ferrules of 0.345 in internal diameter, the dielectric mouldings for this cable are the same as those for the 0.345 in cable, and so three sets of inserts and plungers are enough for joints between any combination of the three sizes of cable. Fig. 2 shows typical joints at the moulding stage.

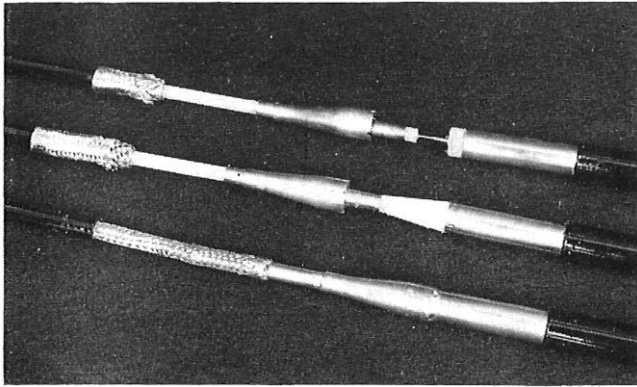

FIG. 2—Typical joints at the moulding stage

On each end of the mould box a metal projection is fixed, and these projections engage with the cross-piece extension on the plunger to prevent it turning during the moulding operation and thus producing a badly-shaped dielectric. A graduated scale is marked on the projection pieces to indicate the extent to which the plunger has been depressed. Metal clamping-pieces are fixed to each end of the base plate to hold the cables securely and to ensure that they enter the mould box at the required angle. The electrical heating elements are wired to plug-in connectors for easy connexion to the power supply. A rotary thermometer is mounted in the body of the mould box for temperature-control.

## JOINTING METHOD

The cable-ends are brought together and overlapped. The outer sheath and polythene dielectric are then removed to expose the centre conductors, which are then jointed by brazing, using electrically-heated tongs. The appropriate mould-box inserts are selected and fixed into position, and the compression mould assembled over the cable to enclose the jointing gap. Polythene granules are poured into the compression mould, and the plunger associated with the inserts is placed in position. The power supply is connected

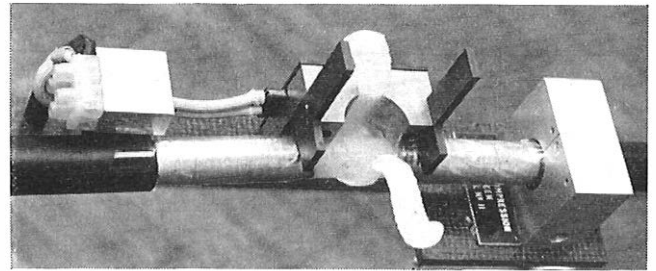

FIG. 3—Polythene flash being removed from dielectric after moulding

and the mould box is heated until a temperature of 150°C is indicated on the thermometer. The power supply is then disconnected, and the cooling cycle is commenced. During this cycle, pressure is applied to the mass of molten polythene in the mould by depressing the plunger gradually with the aid of a screw-clamp. When the cooling cycle is complete, the mould box is removed from the cable and the polythene flash on the moulded shape is easily trimmed from the dielectric (Fig. 3). When one of the smaller-diameter cables is being jointed, the outer conductor is continued across the joint by a copper ferrule of suitable size and shape, but when the largest-size cable is jointed, a length of outer conductor that has been removed from a spare piece of cable is used.

The sheath closure is made using a polythene sleeve sealed to the cable with layers of plastic adhesive tape.

## CONCLUSION

The moulding equipment described has been extensively used and is now a standard item. Although cheaper methods have been suggested, none has yet been found sufficiently promising to justify the cost of developing and proving it. The method developed appears at present to be the best means of meeting the very high standard of reliability required for the schools-television cable network.

## REFERENCES

- <sup>1</sup> HAWORTH, J. E. The Schools-Television Distribution Network. *P.O.E.E.J.*, Vol. 61, p. 250, Jan. 1969.
- <sup>2</sup> ROBINSON, H. E., and ANGELL, F. W. Jointing of Cables Containing Type 174A Small-Diameter Coaxial Pairs. *P.O.E.E.J.*, Vol. 57, p. 132, July 1964.



# A Land-Rover-Mounted Winch

M. DOHERTY†

U.D.C. 629.114.7: 621.315.292

*Until recently, most external cabling work has been performed by a trailer-mounted capstan-winch pulling a separate cabling rope. This requires at least two towing vehicles, one for the cable trailer and another for the winch. A Land-Rover station wagon with an integrally-mounted winch of new design has been developed to provide a truly mobile winch for cabling parties.*

## INTRODUCTION

Land-Rover station wagons have been used for several years by cabling parties as personnel carriers and towing vehicles. The need for a mobile cabling winch, preferably with its own captive rope, led to the fitting of a centrally-mounted "bull" winch in the Land-Rover station wagon Type 3. This unit, in conjunction with a cabling vehicle carrying tools and equipment, and towing the cable-drum trailer, is expected to be used for the majority of cabling work, until more sophisticated plant becomes generally available.

## DESCRIPTION OF THE VEHICLE

The winch is mounted, with its take-up drum of rope, beside the driver in the centre of the vehicle and is driven by the vehicle engine through a power take-off (see Fig. 1). The cabling rope is fed under the vehicle through a pulley to the rear.

The winch controls, which are mounted at the rear near-

side of the vehicle to give the winch operator a clear view of the cabling operations, consist of a clutch lever and a winch gear-change lever, that allows the cable to be pulled-in or paid-out. The clutch lever protrudes beyond the rear door of the vehicle when in use (Fig. 2) and can be folded back when travelling. It is connected to the vehicle clutch hydraulically so that when raised the clutch is engaged and when pressed downwards the clutch is disengaged. The engine speed is also controlled by this lever. The clutch handle incorporates a safety button on its end which must be held depressed when the clutch is engaged. Release of this button whilst the clutch is engaged disconnects the engine ignition to stop the engine and winch. The clutch handle can be held in the disengaged position by means of a catch. In this position the emergency ignition cut-off button is inoperative so that the engine will continue to run.

The Land-Rover is also provided with a four-wheel brake-locking system, which locks all the wheels during cabling operations. Jacks (Fig. 3) are provided at the rear of the vehicle to relieve its springs from loads imposed by cabling operations. A rope or cable guiding attachment (Fig. 3) is provided for use in joint boxes and manholes. It consists of a pair of stout

† Civil and Mechanical Engineering Branch, Telecommunications Development Department.

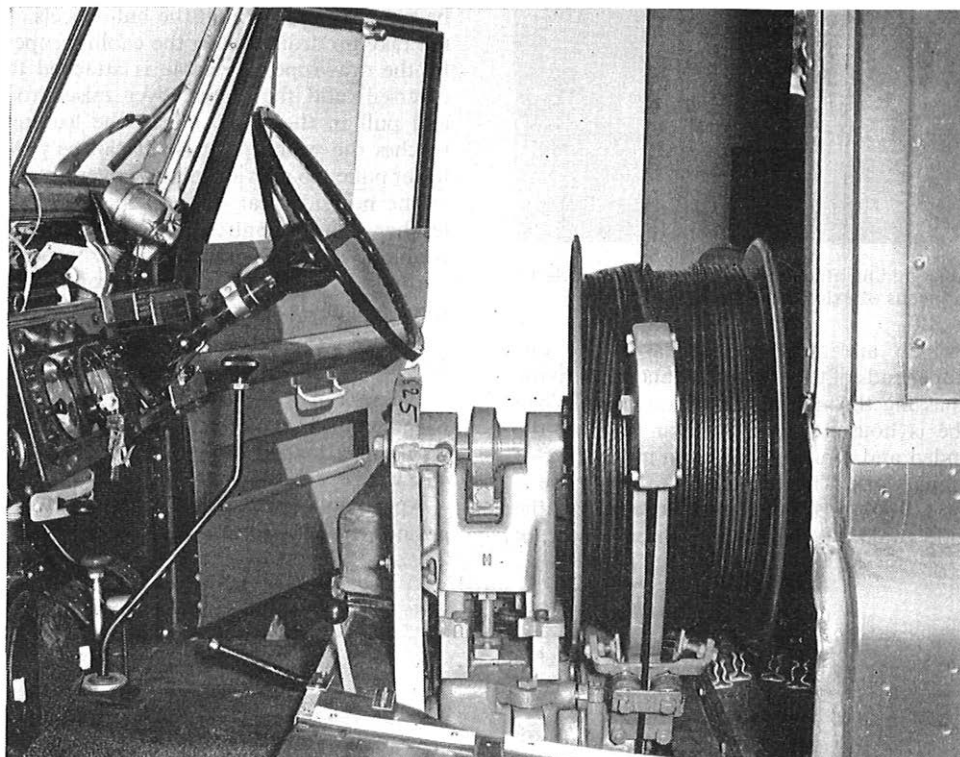

FIG. 1—Winch and take-up drum beside the driving seat

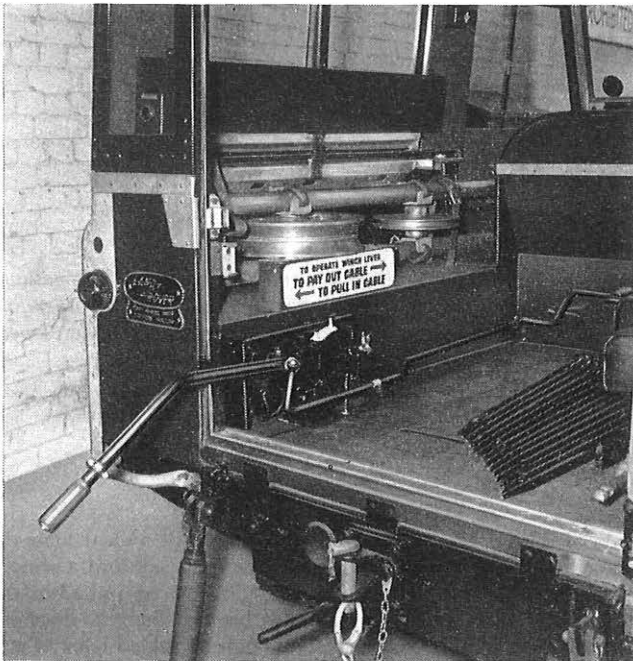

FIG. 2—Winch controls and cable guides stowed for travelling



FIG. 3—Rope or cable guiding attachment anchored to vehicle by means of extension tube

parallel tubes to which are attached one large and one small pulley. The upper ends of these tubes are anchored to the vehicle by a bolt passing through an extension tube. When travelling, this tube is housed under the rear floor of the vehicle but is extended and pinned in position at the rear of the vehicle for cabling work. The end of the cabling rope is normally stowed on a hook positioned under the rear of the vehicle, and the rope guide attachment is secured on top of

the nearside seating position in the vehicle by fixing straps. (Fig. 2.)

### WINCH DESIGN

The winch driving-mechanism consists of two “bull” wheels of equal diameter, each having several grooves round which the cabling rope passes (in the manner of a pair of multi-sheave pulleys) before being wound on the take-up drum. The two bull wheels are geared together and the mechanism works in a similar manner to a capstan winch except that the take-up drum applies the tension to the loose end of the rope. Since the rope runs in grooves on the bull wheels, there is no jumping of the turns as can occur on a capstan when the rope creeps towards the major diameter and suddenly slips back to the minor one. The bull winch operates smoothly under load and, because the rope is coiled automatically, requires only one man to operate it. It is also compact and self-contained and there is no need for separate reels of cabling rope.

The take-up drum is chain driven from the winch gearbox through a sprocket containing a slipping clutch which is preset to maintain a tension of 100 lb on the cabling rope as it leaves the bull wheels. This take-up drum contains 500 yd of polypropylene-covered steel-rope,  $\frac{1}{4}$  in diameter, but may, if desired, be fitted with 450 yd of 8 mm steel rope. The winch drive incorporates a safety over-load clutch which is adjustable to the safe-working tension of the rope being used. For  $\frac{1}{4}$  in rope this is 2,500 lb and for 8 mm rope 4,000 lb. During cabling work the Land-Rover gearbox is engaged in second gear with the transfer gearbox in neutral. This gives a cable speed of approximately 120 ft/min with an engine speed of approximately 1,250 r.p.m.

### CABLE PULLING

For normal cabling work, the rope or cable guiding attachment is first fitted to the rear of the vehicle and then lowered into the joint box or manhole. The cabling rope is then fed from the winch over the top pulley and under the lower one and attached to the drawrope in the duct. The other end of the drawrope is pulled out by a small self-winding winch normally carried by the cabling vehicle. During paying out of the cabling rope, the bull winch must be run in reverse so that the bull wheels can pull the rope off the take-up drum. When the cabling rope has been drawn in by the drawrope, the cable is attached to it, the bull winch reversed, and the clutch lever raised to engage the clutch and pull in the cable. When the leading end of the cable reaches the winch position, it can be pulled round the large lower pulley to provide jointing overlap. An operator standing at the nearside rear of the vehicle during cabling, with his left hand on the control handle, is clear of the line of pull and is able to see both down into the box and in the direction of the far end of the duct. Radio communication can be used when cabling is in progress.

### CONCLUSIONS

The mobility of the vehicle and the ease of operation have been favourably commented on by users. The Land-Rover can also pull a loaded cable-drum trailer with a total weight of 45 cwt.

Approximately 100 of the items have been purchased and are now being made available to the field.

# Stored-Program Character Storage for Automatic Error-Correcting Telegraph Systems

C. S. HUNT†

U.D.C. 621.377.6: 621.394.34: 621.394.18

*Signal-storage devices are necessary to permit the use for telex of h.f. radio-telegraph links incorporating automatic error-correcting systems. The latest type of buffer store, using stored-program shared ferrite cores, is described in this article.*

## INTRODUCTION

A recent note<sup>1</sup> gave a brief history of developments in telegraph buffer-store devices. Starting with the fully-automatic reperforator transmitter distributor (FRXD), an electro-mechanical device using punched paper tape, and progressing to magnetic-drum<sup>2</sup> and magnetic-tape devices using transistor logic, it was mentioned that the ultimate aim was an equipment with no moving parts, thus reducing the need for maintenance attention to a minimum. The equipment described in the following paragraphs achieves this.

Fig. 1 illustrates in simplified form the interconnexions between the telex customer's teleprinter, the automatic error-correcting (ARQ) equipment and its associated telex unit, and the store. Under the combined control of the telex unit and the ARQ equipment, the store is required to act as a buffer so that the random arrival of traffic from the telex customer may be compatible with the synchronous operation of the ARQ equipment. Additionally, it provides storage of the traffic during the time that the ARQ system is cycling. Therefore, the store is required to,

(a) accept start-stop sequential characters arriving as traffic from the telex customer at intervals independent of the timing of the ARQ transmission path,

(b) store the characters in their 5-unit combination form,

(c) under the control of character-read-out pulses from the ARQ equipment, via the telex unit, transfer characters one at a time from the store to the ARQ channel input in 5-wire parallel form,

(d) signal to the ARQ equipment via the telex unit whether there is traffic in the store or not, and

(e) signal to the telex unit when all the store capacity is in use (the telex call is then released).

Buffer stores are designed to accept characters at the nominal teleprinter rate of 400 per minute, and to dispose of characters from the store at 411 characters/minute. Thus, the stored characters are sent out at a faster rate than they are put in, and, although the store may contain a large number of characters, providing the radio circuit operates without further interruption, it eventually empties even though the input continues.

In the past, the store capacity has been based on the radio-circuit efficiency being as low as 50 per cent, which would require 195 characters/minute to be stored, and storage of a message of 20 minutes duration. This resulted in a store capacity of 4,000 characters per circuit being adopted.

In the future, however, the maximum storage capacity required is likely to be reduced, as a recent C.C.I.T.T.\* recommendation is that telex calls over ARQ circuits shall be forcibly released if

(a) the efficiency of the circuit falls below 80 per cent for 20 consecutive seconds, or

(b) a comparatively limited store capacity has been filled (700-800 characters is suggested).

The stored-program shared ferrite-core store about to be described shares a capacity of approximately 24,000 characters

† Mr. Hunt is in the Data, Telex and Telegraph Systems Planning and Provision Branch, Network Planning Department, Telecommunications Headquarters.

\*C.C.I.T.T.—International Telegraph and Telephone Consultative Committee.

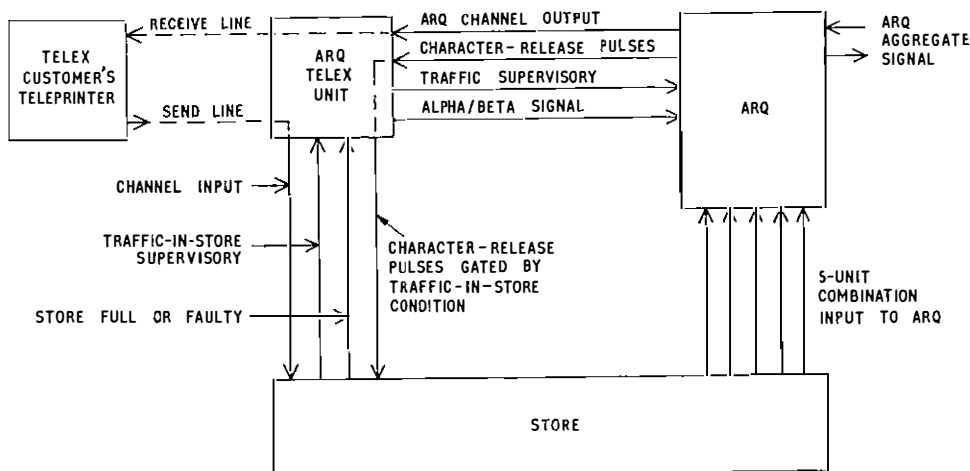

FIG. 1—Interconnexion of telex station, ARQ equipment and buffer store

between a maximum of 15 circuits, permitting storage of approximately 1,500 characters per circuit if all 15 circuits demand it simultaneously. This is an unlikely event in practice, and if necessary the load can be spread by a judicious selection of routes with peak demands occurring at different times of the day. Each circuit is allocated a fixed minimum of 512 characters, but, at the other extreme, if only one or two circuits are demanding storage above this figure, each can store up to 8,000 characters by drawing on the storage capacity common to all circuits.

The common store can also be supplied in capacities of 8,000 or 12,000 characters, and it could well be that in the light of experience one of the smaller capacities will be found to be sufficient.

### GENERAL DESCRIPTION OF BUFFER STORE

The equipment is basically a real-time information processor programmed to carry out the required functions after a series of specially-prepared punched tapes containing instructions in an 8-unit machine code have been read into its program store. The heart of the equipment is the control processor, a ferrite-core memory with an instruction counter for the continuous processing of the program, and information processing loops which are called in by the program. Input and output units provide an interface between the processor and the 15 traffic circuits external to the store; an additional circuit is provided for local connexion to a teleprinter, for printing-in operational instructions and receiving operational information from the equipment (Fig. 2). A separate input is provided for feeding-in the programs from a tape-reader.

The rack (Fig. 3) is  $86\frac{1}{2}$  in  $\times$   $21\frac{1}{4}$  in  $\times$   $10\frac{7}{8}$  in and houses all the units for 15 traffic circuits and one control circuit. There are seven shelves of plug-in book units; one shelf contains the core store and associated amplifier units, and one shelf a panel for monitoring and equipment control. Three other shelves hold the mains-operated stabilized power units and a battery for eliminating the effect of short breaks in the mains supply. Input and output circuit connexions are made on tag blocks at the top of the rack.

All semiconductors are silicon type, in both discrete and integrated circuit form, and fan cooling is provided. Mains power consumption is approximately 500 watts.

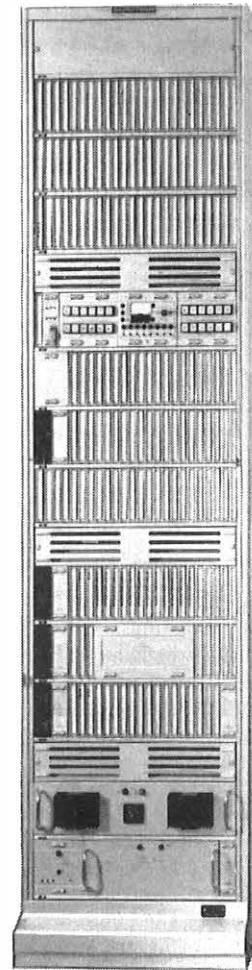

FIG. 3—Buffer-store rack

### Core Store

The coincident-current core store is composed of a series of core planes, each plane comprising  $64 \times 64 = 4,096$  cores.

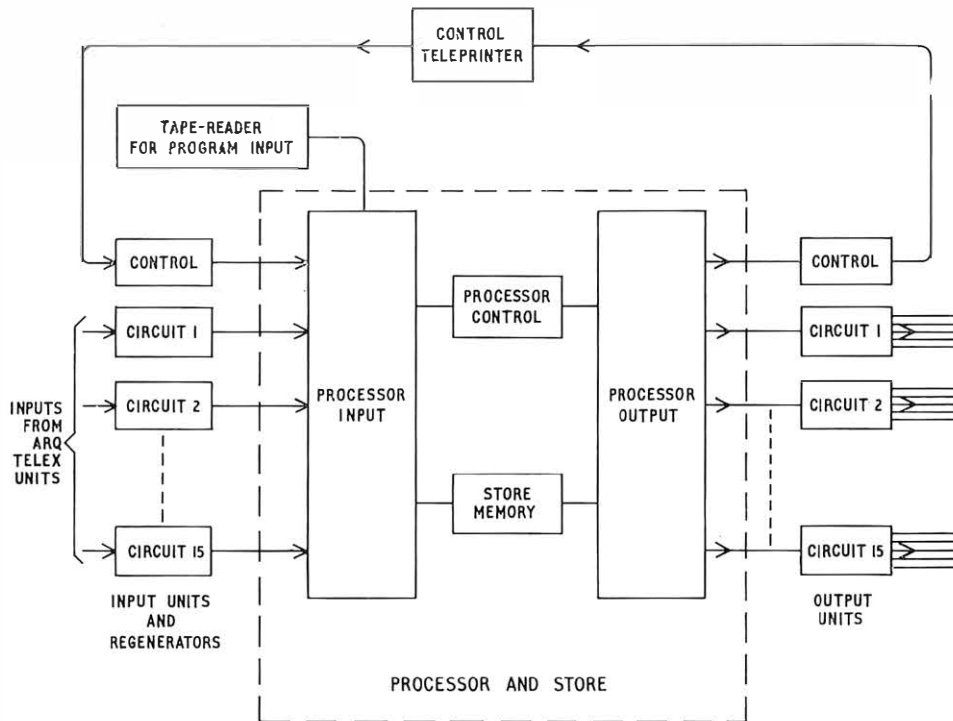

FIG. 2—General arrangement of buffer store

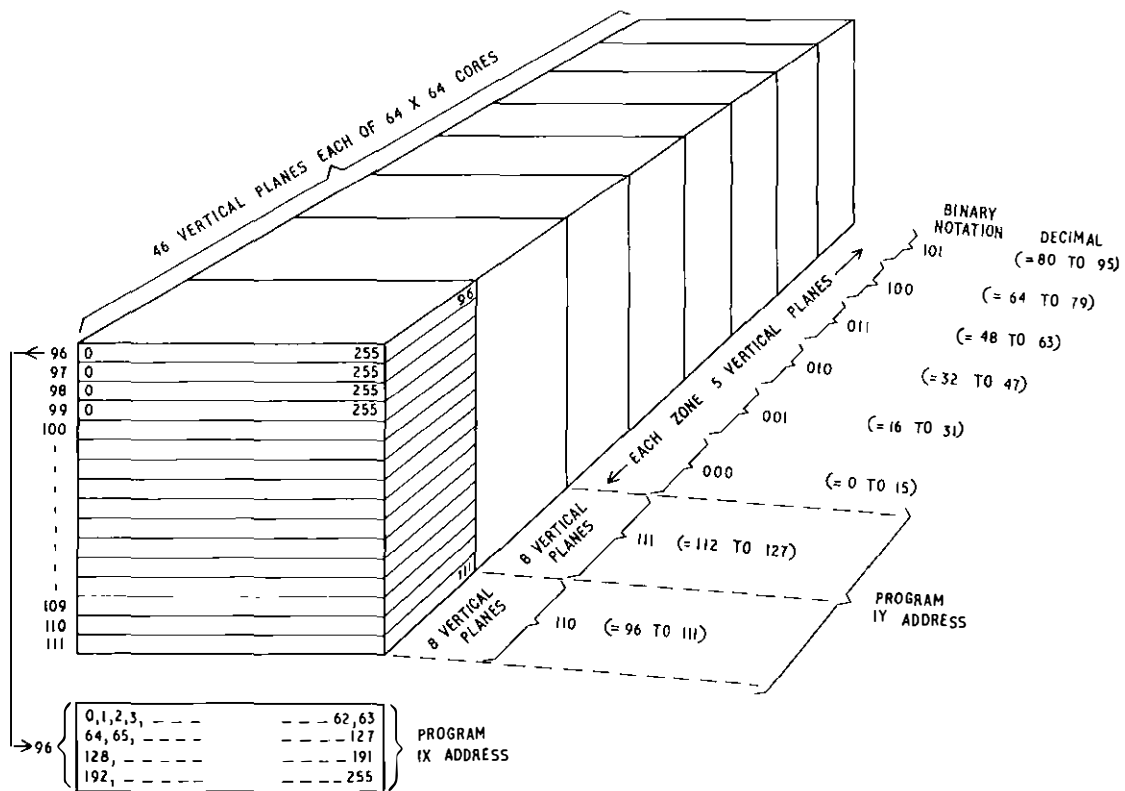

Fig. 4—Core assembly and addressing system

There are 46 planes in the assembly, divided into two groups (Fig. 4). For storing program instructions an 8-bit code is used, and two zones each of eight planes are required, giving a capacity of 8,192 8-bit words. In the section of the store catering for traffic information in 5-bit code, six zones of five planes each provide a capacity for  $6 \times 4,096 = 24,576$  words. This gives a total of 32,768 (or  $2^{15}$ ) word positions requiring addresses. Thus, a code containing 15 bits is necessary for addressing: six bits for the X axis, six bits for the Y axis and three bits for the Z (zone). These are incorporated in one 8-bit and one 7-bit word as shown in Fig. 5.

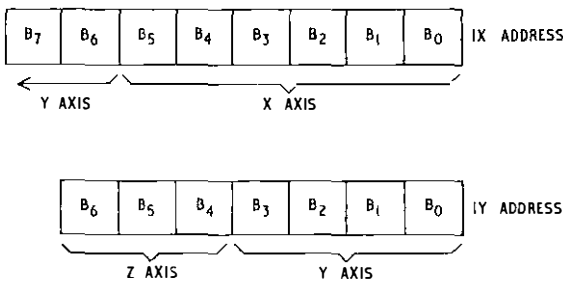

Fig. 5—Eight-bit and 7-bit address codes

To address the program memory only one bit is required, as there are only two zones.

The information store is divided into 96 blocks of 256 5-unit traffic characters each, and each circuit is given a minimum storage capacity of two blocks, or 512 characters. Traffic information is stored consecutively in the first block, the second block serving as a standby. Once the first block is filled, traffic continues and is stored in the second block. At the same time a search is made to earmark a third block and this can continue, providing there are blocks unallocated, up to a maximum of 32 blocks. The stored characters are transmitted consecutively from the first block, and when transmission from the second block commences, the first block is released into the common pool. Thus, from one to 256 characters can be stored in each block and the maximum storage capacity one circuit can obtain is 7,937–8,192 charac-

ters. All circuits can together store a total of between 20,496–24,576 characters.

### PRINCIPLES OF THE SOFTWARE

The program store, once the various programs have been sent in, contains a series of instructions to the central processor in machine-oriented language. Each of the processing instructions is designated by a binary number. A circuit block which delivers information is termed a source, and, as there are eight transfers of information required, three bits are sufficient to specify them, whereas those circuit blocks, termed sinks, which receive information, require five bits to specify them, as they are 28 in number. Thus, many combinations between sources and sinks can be effected by the 8-bit program word, of which the first three bits specify the source information, and the remaining five bits the sink information.

The program word-structure avoids the need for a long instruction catalogue, and the instruction decoder becomes correspondingly simpler. The transfer of instructions is effected on two 8-parallel-wire highways; one is the collecting highway and connects all sources; the second is connected to all the sinks and distributes information from the sources to the sinks, hence it is termed the distributing highway. Normally, an instruction is executed in one memory cycle, approximately  $6.5 \mu s$ , although there are exceptions, such as the operation of writing and reading, which require two memory cycles, approximately  $13 \mu s$ . The memory cycle is the sequence in which the memory accepts an address, reads out the corresponding cell and re-writes the old information or, if required, writes in new information. At the end of the cycle the address again becomes accessible.

The adoption of the 8-parallel-wire transfer of information speeds up the routing and transfer of information, while the comparatively simple system of software is accompanied by relatively simple hardware.

The programs of instructions are stored in the program zone of the core store in the form of a sequence of instructions having consecutive addresses, a succeeding instruction usually being located in the next higher memory address. All instructions are given specific program-store addresses designated the

PX and PY addresses, and during each memory cycle the address is automatically advanced so that the succeeding cycle causes the extraction and execution of the next instruction. To execute a specific program it is necessary only to set the program-store address of the first instruction for this program, and during normal operation this is performed by the preceding program.

Jumps from one instruction sequence to another are included in programs, whereby the start address for the succeeding program sequence is read into the program-store address. The jump is unconditional when determined by program, but is termed conditional if it is initiated as a result of a combination of decision circuits.

A function which is also required by other programs can be programmed as a routine.

Since the equipment operates in real time, a series of functions is required to be related to the incoming traffic signals and to the calling-out pulses from the ARQ equipment. A fixed priority of programs related to these functions is therefore specified, rendering an interrupt system unnecessary and simplifying the equipment.

The incoming traffic-signal elements arrive at intervals of 20 ms, therefore the program periodicities are based on this time period. Individual programs have different priorities or frequency of use. Thus, that dealing with the reception or transmission of signals occurs every 20 ms, having first priority; that dealing with transfer of information on a character basis occurs every 140 ms; others occur at 980 ms, 1.84 s and 61.92 s intervals. Overall, a master program performs executive functions, in that it calls for a specified program at the required time. Not all programs fill the time-slot available to them, and redundant instructions are fed into program branches if necessary.

Besides the reception and transmission program mentioned above, a storage program transfers characters from receive buffer stores to the information store, and from the information to the send buffer store as required.

The control program allocates storage positions to each channel, remembers the allocated position and the number of characters stored, and responds to instructions received on the control channel. Use is made of program (8-bit) storage not occupied by programs, as buffer stores, channel-information stores for partially-completed characters, block co-ordinating and block-covering stores for the allocation of storage space to each channel, etc.

An alarm program and a test program are also included.

The programs are punched on 8-track tape and are fed in from a tape-reader operating at 250 characters/second. To program an equipment completely, including an initial load program, takes approximately 2½ minutes. The information on the tape is in groups of four characters, as follows.

Group 1: synchronizing character (binary 27)

Group 2: Y address

Group 3: X address

Group 4: the required instruction to be inserted in the X or Y address.

## PROCESSOR

The program repertoire contains the instructions necessary to execute all the logical functions. To do this, information is transferred between sources and sinks. The source outputs are normally closed, and the designated one is opened at the correct instant in the program cycle, releasing the source information on to the collecting highway. Likewise, the sink inputs are normally closed and the designated one opens 3.5 μs after the source opens. For example, to transfer information from register R1 (binary notation 010) to the memory SR (binary 10100), the 8-bit instruction will be in the form shown in Fig. 6.

In the program flow-charts a symbolic representation is used, i.e. R1-SR, and a repertoire sheet shows the eight

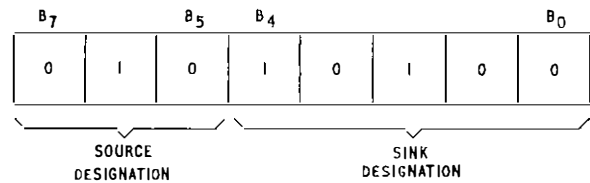

FIG. 6—Eight-bit instruction

sources with their binary and equivalent decimal notation. The 28 sinks and their notations are shown similarly. In addition, there are five additional instructions used for special functions not involving source-to-sink transfers.

The composition of the processor is outlined briefly below; for ease of description the processor can be divided into five sections (see Fig. 7).

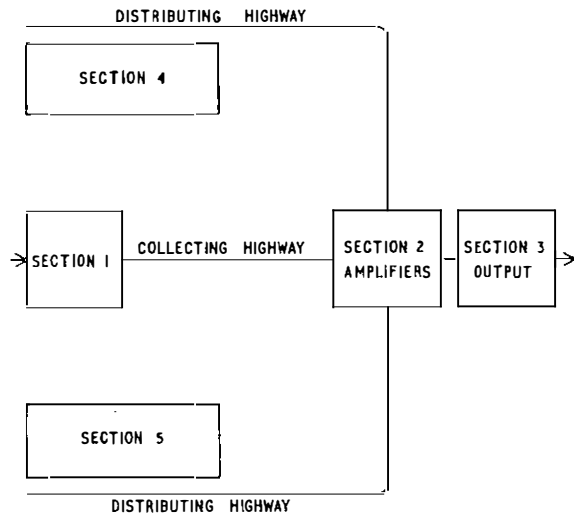

FIG. 7—Central processor

Section 1 is composed of input-circuit units with associated signal-regenerators, and the input matrix or address register for the selection of the desired channel input. It also includes the core memory, which is divided into two parts: the information store, and the program store containing the control program.

An instruction decoder, with its associated buffer register, receives the instruction word from the source and puts it into the specified sink. It also directs the special operations not involving a source-to-sink transfer, and, in fact, controls most of the processor operations. The clock-frequency source and pulse-division circuits also form part of Section 1.

Section 2 contains amplifiers and connecting circuits which act as interfaces between the collecting and distributing highways.

Section 3 consists of channel-output circuits, address register and address decoder for the selection of any channel output.

Section 4 may be compared with an address book inasmuch as it comprises address registers containing the addresses of program and information-store positions. The addresses are used to extract stored instructions, and to read information from core-memory locations assigned with their specific addresses. They are also used for writing instructions or information in the memory locations with the assigned addresses.

Five registers are used for addressing program-store locations, while two more are also used for addressing the whole of the core memory.

Section 5 contains units for special functions. Among these are an accumulator register, the contents of which can be added to a word during its transfer from a source to certain sinks and comparator circuits in which an 8-bit constant is

put in, and compared with an unknown 8-bit word. If the two are equal a specified functional signal is given.

The section also contains a single-bit evaluating circuit, in which it is possible to shift the position of a specified bit an arbitrary number of positions, thus influencing any desired output.

### Hardware

Most of the logic units utilize standard types of circuit elements composed of gates, inverters, bistable circuits and diode matrices. Only a very small number can be considered of special design. The use of nominal logic levels based on 0 and +6 volts for discrete semiconductor circuits and 0 and +5 volts for integrated semiconductor circuits, necessitates a signal-voltage-changer device to meet the Post Office specification for interface circuits. This requires a nominal  $\pm 6$  volts into a load of 1,000 ohms and is standard for ARQ equipment and its associated storage and m.c.v.f.t. equipment. It facilitates the necessary interconnection of units and equipments made by different manufacturers.

The incoming-line unit contains the signal-voltage-changer devices, and inspects the incoming line every 20 ms, i.e. for each traffic signal-element period. A regenerator corrects any signal distortion which exists in the incoming signals. All the inputs are combined in an input matrix, consisting of semiconductor elements, through which passes all the incoming flow of information to the central processor. The 16 inputs are divided into two groups of eight, and the state of the inputs is read into the processor by a scanning instruction, each group being dealt with in turn, but both within the 20 ms cycle.

Likewise, all outputs from the equipment are combined in an output matrix, and are also dealt with in two groups of eight alternately. Each output is equipped with a flip-flop circuit to maintain the signal state between changes of condition, and for signal output-voltage conversion. Signals, pulses, supervisory conditions, and control pulses for indicator lamps are all transmitted via the output matrix, the only exception being the monitor output.

### CLOCK-PULSE SUPPLY

All pulses are derived from one 7.68 MHz oscillator, with a frequency stability not worse than 1 part in  $10^4$ , giving sufficient accuracy for the purpose. A series of frequency-divider chains provide pulses of the various periodicities required.

### POWER SUPPLIES

A mains-operated power supply initially generates two 27 volt supplies, + 27 and - 27 volts relative to a common zero potential, with isolation from the mains supply. It is regulated to within 2 per cent, and a 20-cell nickel-cadmium battery is floated across each output, to provide continuity of operation during short breaks in the mains supply.

From these two supplies, series-switching type regulators, which can operate on a range of input voltage 17-28 volts, provide  $\pm 12$ -volt,  $\pm 6$ -volt and  $\pm 5$ -volt supplies.

### CONTROL FACILITIES

As has been mentioned, a channel is provided for the exchange of messages between engineer and equipment. Commands and questions can be initiated from the control teleprinter, to which printed confirmation or answers are given from the equipment. On the other hand, alarms, for instance, are initiated by the equipment, and some are arranged to take priority of printing over commands or requests being made by the engineer at the time. Some fault conditions cannot be printed out, e.g. failure of the central processor which stops the operation of the equipment altogether or

failure of a power supply. A fault of this nature operates a general equipment alarm.

The instructions listed in Tables 1 and 2 illustrate the sort of control facilities that can be provided by such an equipment. The facilities can be used for both maintenance records and statistical information. For instructions that disturb the operation of the equipment as a unit dealing with 15 circuits, the order is repeated back and a request for confirmation (CONF) is made. If CONF is not printed-in within 30 seconds the order is erased.

TABLE 1

#### Instructions that Disturb the Operation of the Equipment

Order	Instruction
GECL	Clear stored information from all channels. The equipment repeats the instruction and adds the equipment code, date and time, and requests CONF. On receipt of confirmation, the operation is carried out. Each channel starts afresh when CONF received.
LOAD PUNCH	Prepare to load program. Prepare for program tape punching by activating the tape punch, and ask for X and Y addresses of beginning and end of program.
RECL (Channel No.)	Clear stored information from a particular channel.

TABLE 2

#### Orders Confined to an Individual Channel and Requiring Confirmation

Order	Instruction
SETT	For setting device-designation, date and time.
SET A (Channel No.)	For setting the percentages of individual channel store occupancy at which printed-out indications are given when these points are reached.
SET B (Channel No.)	For setting an overall store-occupancy figure (in number of blocks) at which a printed-out indication is given.
SET D	Print out the information in the selected store.
PRIM (Channel No.)	Enable control teleprinter to monitor the core-memory input signals of the selected channel.
MONI (Channel No.)	Enable control teleprinter to monitor the core memory.
MONO (Channel No.)	Print out the number of characters in each channel store. Currently this can be effected by working through all channels in sequence.
NSCC	Print out time in 24-hour notation.
TIME	Print out the levels at which the A, B and D store-occupancy alarms are set.
VALA	

### Control Panel

The control panel (Fig. 8) provides facilities for general maintenance operations, in particular for diagnostic routines for faults on the central processor.

A series of press-button keys connects the circuit indicated to a centre row of eight sockets and eight lamps. The sockets permit a check of the voltages of the 8-parallel-wire outputs to be made, while the lamps light for a 1 condition, thus displaying the particular word contained by that circuit.

Two switches in the top row control the mode of operation of the equipment. Normally, i.e. in operation, the programs run automatically when started by the START button and, in this mode, operation of push-buttons will have no effect on the normal operation of the equipment. However, in fault locating, it is necessary to change to a non-automatic mode. The operation is then either one step for each operation of the START button, or conditioned; the equipment then continues to run until a character, previously selected by push-button, enters the required circuit—normally a register.

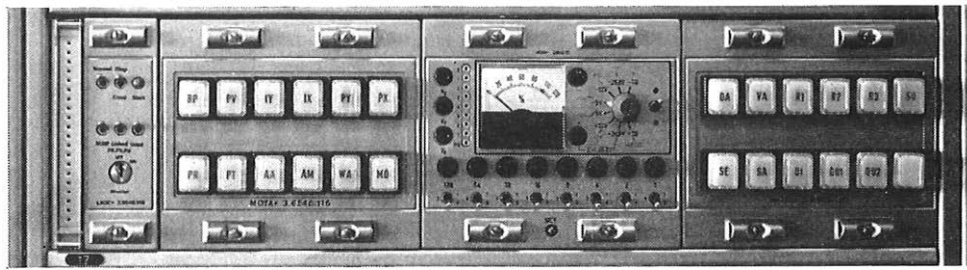

FIG. 8—Control panel

The change of mode from automatic can only be effected by insertion of a master key in a lock on the control panel; thus, accidental or mischievous misoperation of keys is prevented from affecting the normal operation of the equipment.

By automatically comparing the contents of three registers, a limited but continuously-operating test program gives an indication when a fault is found. It is then necessary to implement a diagnostic routine as indicated above.

### CONCLUSION

A stored-program equipment for the storage of 5-unit telegraph characters for ARQ circuits has been described. It combines flexibility and speed of operation with economy of software and hardware. It has no moving parts, thus reducing the requirements for periodic routine testing and maintenance. The design is such that straightforward logic functions of well-known basic designs are used, with very few units of special design.

The equipment provides facilities that assist in operational

and maintenance records, and has the potential of being programmed to provide for fault analysis.

The same basic processor and memory unit, with other peripheral equipment and programs, can be used to provide a 10-line telegraph message-switching system, a traffic controller or a wiring tester.

### ACKNOWLEDGEMENT

Acknowledgement is made to Messrs Hasler, Berne, Switzerland, for permission to use the photograph shown in Fig. 3.

### References

- <sup>1</sup> Telegraph Character-Storage Devices for Telex Services Routed over Radio-Telegraph Circuits. *P.O.E.E.J.*, Vol. 61, p. 119, July 1968.
- <sup>2</sup> ROBINS, J. M., and CROISDALE, A. C. An Electronic Telegraph Buffer Store using a Magnetic Drum. *P.O.E.E.J.*, Vol. 56, p. 262, Jan. 1964.

## Telecommunications in Power Stations

G. A. BARTLETT, B.S.C.(ENG.), M.I.E.E. and A. F. WALKER†

U.D.C. 621.311.1:621.39

*Communications links, many of which use lines rented from the Post Office, terminate in power stations and often require protection from the effects of rise of earth-potential. Line-isolation techniques, which also afford protection to personnel, are at present required by the Post Office if the rise of earth-potential at a particular station is likely to exceed the acceptable limit. A pilot scheme at Ironbridge power station has shown up special difficulties when both Post Office equipment and Central Electricity Generating Board equipment have to be isolated from line. Modifications to this scheme are described, which will avoid the need for the Post Office to provide cables for the distribution of communication circuits throughout new power-station sites in the future.*

### INTRODUCTION

The electricity industry is expanding and additional generating plant is being commissioned every year. Each power station has its output connected into the electricity grid transmission-network which supplies electricity in bulk to all parts of the country. The growth of this system requires, in turn, many new substations to distribute the energy. In England and Wales, under the control of the Central Electricity Generating

Board (C.E.G.B.) there are 226 generating stations and 755 substations, and this number is being increased at the rate of about two new power-stations and 50 new substations annually.

It is possible at some stations, under power-fault conditions on the associated network, for the earth-electrode system to rise to a high potential. Unless this voltage is neutralized, or prevented in some way from entering the telecommunications network which serves the station, it could damage plant and be a danger to personnel. Only the power-engineer can say when and whether or not the conditions at a particular station

† Civil and Mechanical Engineering Branch, Telecommunications Development Department, Telecommunications Headquarters.



are likely to cause a high rise of earth-potential. If precautions are necessary, the Post Office requires equipment which terminates each telecommunications circuit entering the station to be electrically isolated in a special way from the line plant.

The number of Post Office lines and the use to which they are put varies from station to station but the pattern of requirements is the same. It is easier to obtain safety if installation instructions for Post Office plant are simple and isolation equipment can be provided or recovered without major rearrangements of cables.

This article describes and explains the main hazard in taking telecommunications circuits into electricity generating and transmission sites. The Post Office has provided most of the telecommunications cables throughout a new C.E.G.B. power-station site at Ironbridge, from which has emerged a standard method for the distribution of Post Office services through all new C.E.G.B. stations in the future.

## THE ELECTRICITY GRID TRANSMISSION NETWORK

For economic reasons, power is transmitted at voltages as high as 400 kvolts. There are about 15,000 circuit miles of transmission line at present in service in England and Wales constituting the national grid-network. This figure is made up of underground cables and overhead lines operating at 400, 275 and 132 kvolts.

The bulk supplies are distributed through substations which are switching and voltage-transforming points. Formerly, generating stations were also switching stations, but now the marshalling and switching of the 275 and 400-kvolt systems is mainly done at separate substations. The power now available at these can be greater than that handled by a single generating station.

## TELECOMMUNICATIONS

A fault on remote high-voltage plant must cause a signal from a protection device to be promptly transmitted and translated so that a section of power line can be disconnected or a transformer in a substation tripped out. Rapid signalling between stations is essential if destruction of the faulty power-plant is to be prevented but this protection can only be guaranteed if the communication link between items of equipment is available at all times and immune from false signals. The relative merits of different types of signal and the different kinds of link over which they can be transmitted is of international interest.<sup>3</sup> Lines may be rented from the Post Office for general control, for protection purposes or for exchange line services.

To supervise and co-ordinate the operation of the grid network there must be communication links between power-stations and substations. The C.E.G.B. communication links include pilot-cables, for short distances, power-line carrier and radio, but the majority of links (about 2,300<sup>1</sup>) are 2-wire and 4-wire circuits rented from the Post Office and use terminal-apparatus<sup>2</sup> owned by the C.E.G.B.

## General Control and Administration

Groups of stations in each area come under the direction of a Grid Control-Centre<sup>4</sup>, whilst overall control and co-ordination with Scotland is maintained through the National Control-Centre in London. The control engineer can cause each circuit to simultaneously carry a telephone conversation and monitor the grid-network at various points. Telephone calling and clearing is usually transmitted by pulse-trains over an earth-return phantom-path and this channel is also used in sequence to indicate whether circuit breakers are open or closed. When d.c. signalling cannot be used, suitable filtering enables a tone outside the speech band to be employed.

## Protection

The reliability of the 1,350 Post Office lines used as links for high-speed protection is vital. A fundamental difficulty is that the C.E.G.B. requires circuits of very high reliability and is prepared to pay for any improvements to achieve this. The Post Office network, however, is designed to provide circuits of a lower reliability at lower costs for the bulk of customers. To overcome this incompatibility the C.E.G.B. usually duplicates each circuit and the terminal apparatus, using circuits which are physically separate throughout and between the terminal-stations. The two circuits each have an out-of-service time of about 13 hours per annum, but together obtain a much higher reliability, at a price which is still considerably less than the cost of the C.E.G.B. laying its own national network of robust pilot-cables.

## THE EFFECT OF POWER-SYSTEM FAULTS

At power-generating and transmission stations a low-resistance connexion is made from the neutral of the high-voltage system to the general mass of earth. This connexion ensures that when a fault-to-ground occurs on a power-transmission line a return path for fault current is available.

A potential rise, with reference to true earth, will be set up whenever a current enters or leaves an electrode in contact with the main body of the earth. Usually within a power-station all the metallic pipes and the building framework are bonded to the buried system of rods or tapes forming the earth electrode. Therefore, the station earth cannot be clearly defined and the whole complex will be liable to a potential-rise in the event of a fault-to-earth on a transmission line which terminates at the station.

Telecommunications cables led into the station must pass through the potential-gradient area and have the full rise of earth potential impressed upon them and their terminal equipment. In order to minimize electric-shock hazards to personnel, to avoid damage to telecommunications plant and to prevent false signals, protective measures must be taken. The various dangers are not too great if the extraneous voltage in the telecommunications line is not allowed to exceed 430 volts.<sup>5</sup> This voltage may be increased to 650 volts if the power lines are equipped with protective devices and switch-gear which restrict the duration of most earth-fault currents to less than 0.2 seconds. The systems on steel towers carrying voltages of 132 kvolts and above are in this category and are termed highly-reliable.

Currents in excess of 10,000 amperes can flow in the event of an earth-fault on the grid network. In regions of high earth-resistivity it is impracticable to lower the resistance of the station earth-electrode system to an extent which prevents the rise of earth-potential from exceeding the acceptable limit. However, part of the fault-current can return along the tower-line earth-wires back to the station and need not flow over the station earth-electrode system.

Telecommunication services must be provided at an early stage in the construction of a station when the power plant is incomplete and the station earth-electrode is not available for the Electricity Board to give other than a rough estimate of its contribution to the earth-potential rise. Hence, there is a problem of how far to proceed with expensive protection measures if in time it might be shown that they are not required. Some safety features are so basic to the system of protection which has been chosen that they must be initially incorporated. However, it must be possible to take additional measures later, without major rearrangements to the communications system if more accurate information on rise of earth-potential shows them to be necessary.

## LINE-ISOLATION EQUIPMENT

If the rise of earth-potential is likely to exceed the appropriate limit, one method of removing the dangers is to isolate the terminal equipment in the station from the line plant.

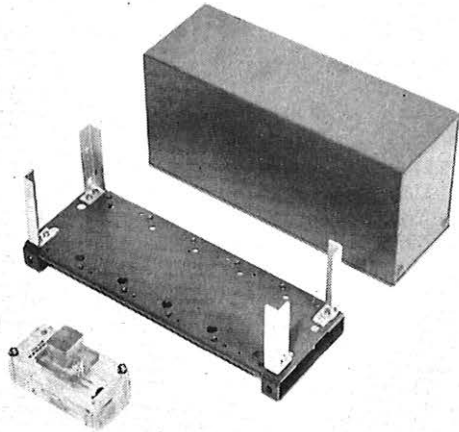

FIG. 1—Isolating Link No. 5A and mounting for 5 links

A two-winding transformer of suitable impedance ratio can be inserted as a barrier in the line, and insulation to withstand at least 5 kvolts can be included between the primary and secondary windings. This type of line isolation has been adopted by the Post Office and implies that all conductors on the line side of the barrier are substantially at remote-earth potential and all conductors on the office side are at station potential.

The Post Office terminates each pair of wires in an outlet-cable on its own isolating link. The link has a plug and socket shrouded in insulating material so that once it is assembled it is not possible to touch any metal of the wires or terminals. When the plug is taken out of the socket an insulation of at least 5 kvolts is presented across the gap between line-side and office-side connexions and access to any office-side wiring or terminal equipment is made safe. An open-circuit test can be made from the remote exchange to this point of disconnexion. A short-circuiting plug enables either a line-loop, or a loop from the terminal equipment back to the link, to be investigated, depending on which way round it is inserted. Fig. 1 shows the complete assembly of a Isolating-Link No. 5A.

The line-isolating units do not interfere with, or modify, the signalling and transmission performance of a circuit when inserted between the line and the terminal apparatus. All lines entering a station at which the rise of earth-potential changes from below to above the limit can be isolated at short notice by inserting the appropriate unit in each circuit at a point adjacent to the isolating link.

When a barrier is required on a direct-exchange line, for which the Post Office provides the telephone instrument, a Line-Isolating Unit 1A is connected to the link. The unit, (Fig. 2), is so constructed that all the wires and components associated with the line side are in an insulated compartment and cannot be touched unless the unit is deliberately dismantled. A transformer with suitable primary to secondary winding insulation is mounted in the unit for connexion in the line. This transformer will only pass ringing and speech frequencies, so isolating reed-relays, energized from a local 50-volt d.c. supply, are provided to repeat dial-pulses in the office-to-line direction. Units for other services, e.g. long extensions and exchange-lines terminating on PBXs, are being developed.

Ideally the Post Office should isolate all pairs before they are extended to the terminal equipment but the lines used for the C.E.G.B. private network are mostly terminated on apparatus owned by the C.E.G.B. and designed in a way that has required the line isolation to be progressively incorporated in the components of the terminal apparatus. Therefore, physically separate line-isolating units, which can be inserted

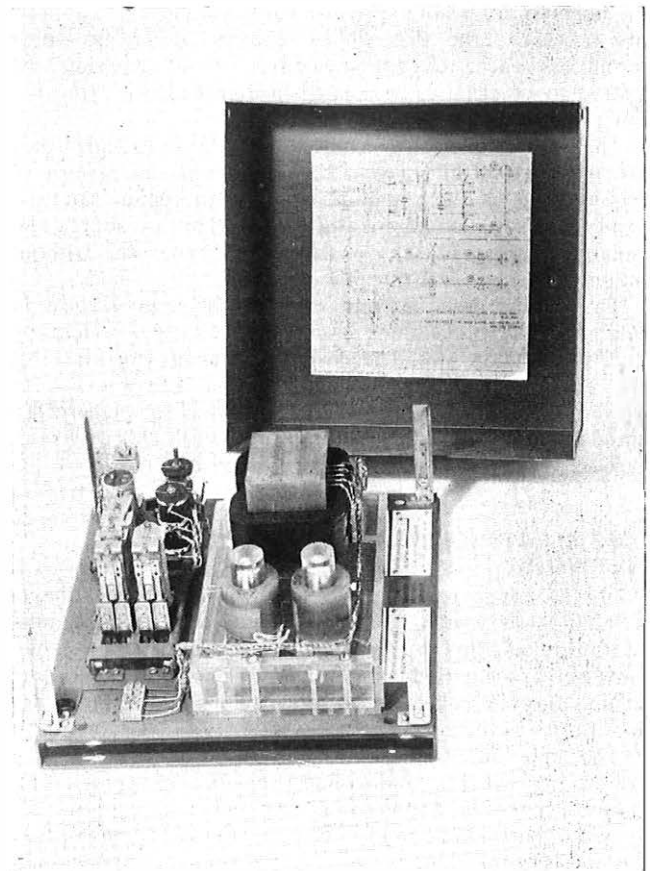

FIG. 2—Line Isolating Unit 1A

or omitted as required by rise of earth-potential considerations, cannot be realized. Hence, it is necessary to distribute both isolated and non-isolated circuits throughout the generating station. No problem is presented if individual one-pair cables are used but since multi-pair cables must be used, wires from the line-side of any barrier must not be run in a cable together with wires from the station side if benefit is to be gained from the high-grade insulation of a barrier-transformer.

Special difficulties arise when attempts are made to include flexibility points in telecommunications cables which have not been isolated, in particular when apparatus must have access to alternately-routed circuits, but these difficulties are not insurmountable.

#### WIRING AND CABLING AT IRONBRIDGE POWER-STATION SITE

The site at Ironbridge originally contained an "A" station and substation supplying power to the 132 kvolt grid. In 1966 the building of a "B" station was completed and feeds power into the 400 kvolt transmission-network. The Post Office decided to terminate all their outlet cables at one point in the new 400 kvolt control-building. From the position where the isolating links are fitted in the telecommunications room, the circuits for which the Post Office provide isolating units are kept entirely separate from circuits, e.g., private circuits (p.w.), for which the CEGB provide isolating units or suitably isolated terminal equipment. Fig. 3 shows in outline the cables to and throughout the site.

#### Circuits on which the Post Office Provides Isolating Units

From the office side of each isolating-link associated with outlet No. 1, a cable is taken to a connexion box for the subsequent distribution of exchange-line services. Sufficient

space is left on the equipment wall-board to mount line-isolating units which can be inserted in the cable between the link and the connexion box.

**Circuits on which the CEGB Provides Isolating Units and Terminal Equipment**

From the office side of each link a single-pair cable is taken to a terminal box provided for outlet No. 2. This terminal box is made of glass-fibre and special insulation exists between the metallic connexions in the box and the station earth-system. Also, the terminal screws are recessed in a block of insulating material so that when a wire is being secured it is unlikely that accidental contact will be made with any other terminal. From this terminal box, cables, carrying conductors which have not been isolated from the remote-earth potential, are taken to both the 132-kvolt compound and the 400-kvolt compound.

**Duplication of Circuits in Case of Damage**

Outlet No. 3 has been provided with its circuits extended through their own terminal box as the alternative route for protection circuits. In each compound the extended-outlet cables come together in a common terminal box so that some of the privately-owned equipment can be connected to one outlet and some to the other. Up to this point the cables, except at the isolating links, are as far apart as the site layout will allow. Each extended-outlet cable is in one length without joints and the relevant isolating-link must be removed before any work is done which requires access to a cable conductor within a terminal box.

**WIRING AND CABLING AT OTHER NEW CEGB SITES**

As a result of experience gained at Ironbridge, new considerations are to be taken into account when other new sites require Post Office service.

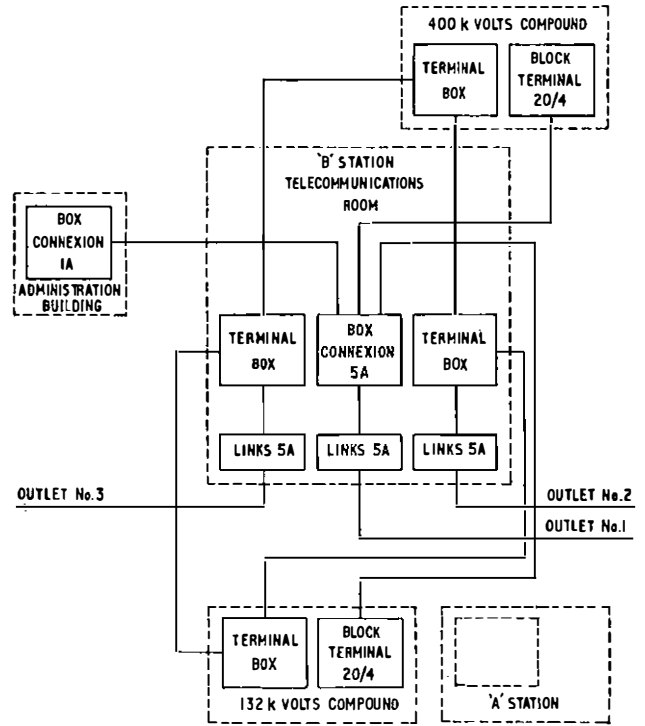

FIG. 3--Post Office network provided at Ironbridge, C.E.G.B. power-station site

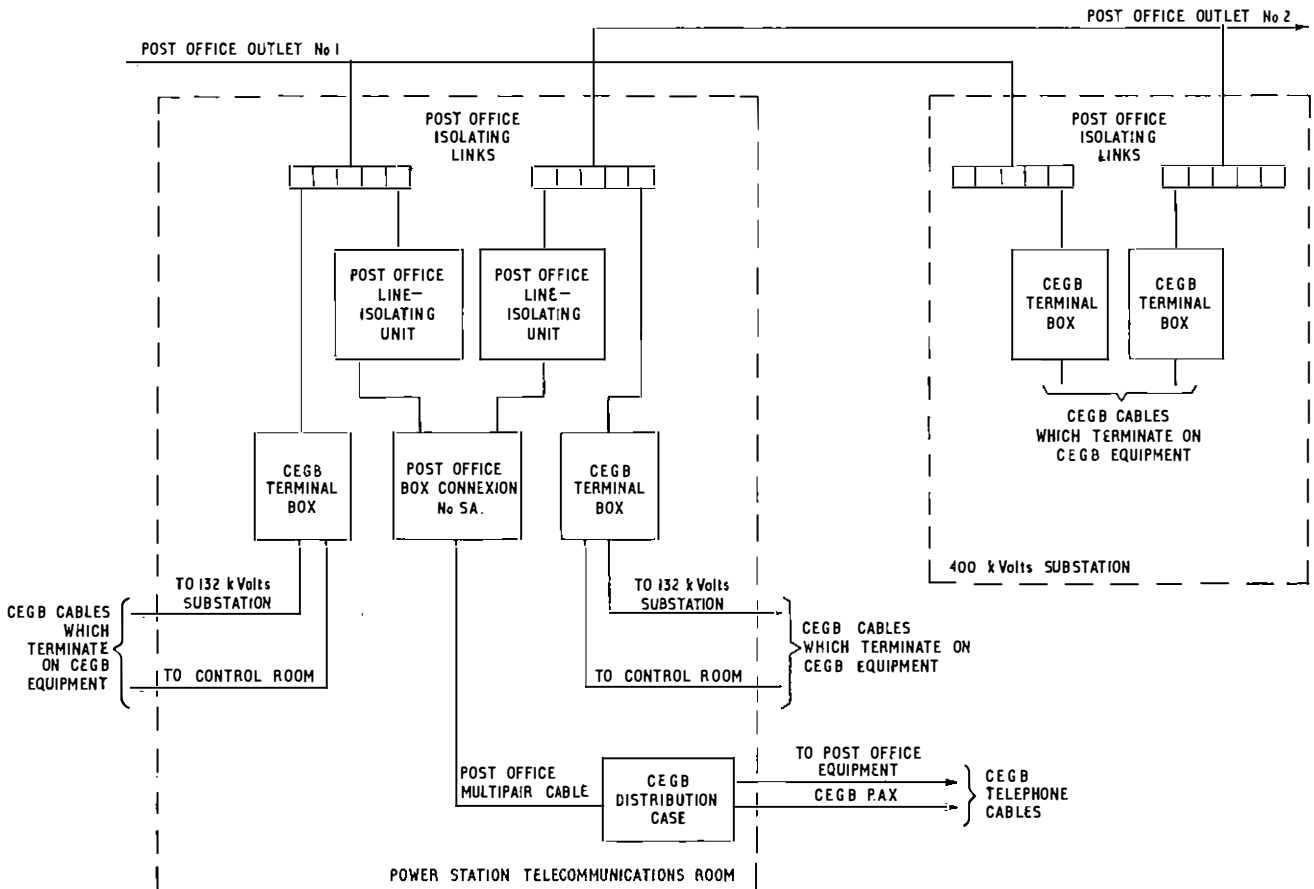

FIG. 4--Wiring and cabling to be provided at most new power-station sites

The provision of Post Office line plant in power stations creates problems. Post Office engineers have to provide services in unfamiliar environments associated with high voltages, and permission must be obtained before entering certain areas. It is unwise to diversify cables both on and off site only to distribute them through a common terminal point because disaster, such as a fire or an explosion in the telecommunications room could damage the cable terminal equipment to cause loss of all communications.

To obviate Post Office difficulties the C.E.G.B. intend in future to provide all the cables to distribute the circuits away from the building in which the Post Office outlet cable terminates. In view of the isolation requirements, each cable must be used exclusively, either for site purposes or for extended-outlet purposes. Armoured cables will be provided throughout. The Post Office network of site cables which distributes the telephone service is a duplicate of the C.E.G.B. PAX network and, in the future, pairs will be made available in C.E.G.B. PAX cables for the distribution of exchange-line services. The number of extended-outlet cables can be considerably reduced if the Post Office provides outlet cables to more than one terminal point on the site, e.g. one in the power station and one in the 400-kvolt substation. For the p.w.s., individual one-pair cables will be wired by the Post Office from the isolating-links to an adjacent terminal box, owned by the C.E.G.B and provided with high-grade insulation. Exchange-line services will be connected, via Post Office equipment, to a distribution case owned by the C.E.G.B. but used for both Post Office exchange-line and PAX telephone purposes.

Fig. 4 shows a typical arrangement which incorporates these changes and which will apply at new sites in the future.

### SIGNALLING EARTHS

If there are possibilities of a high rise in earth potential, restrictions must be placed on the use of the station earth for signalling purposes. While it is safe for the station earth to be used for earth-recall connexions, which can operate back to a manual board associated with a p.a.b.x. within the site, it is unsafe to extend the station earth outside the site as would be the case with earth-return phantom d.c. signalling.

The C.E.G.B. often require the Post Office to provide a separate connexion for signalling purposes to an earth away from the station, and a uniform technique is followed whenever these connexions are provided. One method has been to run a cable to an earth spike situated some 200 yards from the outermost boundary-fence of the station site. However, a location clear of other buried metalwork, which might be connected to the station earth-electrode system, cannot be guaranteed. Also, it cannot be certain whether or not the

spike is far enough away from the influence of the station earth. The adopted practice, therefore, is to provide a bunched pair in the permanent outlet-cables from the station and extend it to the main-distribution-frame earth at the serving telephone exchange or repeater station. An estimate of the total resistance of the bunched pair together with the exchange earth can be given in advance of the connexion being made to see if the requirements of the C.E.G.B. terminal equipment can be satisfied.

### CONCLUSIONS

In the past few years the electricity grid-transmission network has maintained its steady growth. The capacity of generating plant has increased and the grid is being modified to accept more transmission at 400 kvolts. These improvements have the repercussion that currents in excess of 10,000 amperes can sometimes flow in the event of an earth fault on the grid network.

Signalling functions must be improved in speed, reliability and security if the protection of the power system is to be continued. Post Office circuits can be used for these functions but special problems are presented when circuits for protection, control or telephone purposes are distributed through power-station sites.

There is increasing need for a standard system of wiring and cabling of Post Office services in new power stations and substations, which allow the present policy of line isolation to be economically applied without necessitating alterations in the current design of C.E.G.B. apparatus. The new arrangements which have been described in this article are best suited to the Post Office safety requirements for the protection of personnel and telecommunications plant against rise of earth-potential.

### ACKNOWLEDGEMENTS

Acknowledgements are due to the staff of the Shrewsbury Telephone Area and the engineers at C.E.G.B. Headquarters.

### References

- 1 Communication Links in Electrical Power Control. *Electrical Review*, p. 230, 16 August 1968.
- 2 BURNS, G. A., FLETCHER, F., CHAMBERS, C. H., GUNNING, P. F. The Development of Communication, Indication and Telemetering Equipment for the British Grid. *Proceedings I.E.E.* Paper No. 26275 May 1958 (Vol. 105A, p. 565).
- 3 C.I.G.R.E. Joint 4/14 Committee Report: Teleprotection.
- 4 GUNNING, P. F. Standardization of Control Facilities for the British Grid: Communication, Indication and Telemetering. *Proceedings I.E.E.* Paper No. 26265, May 1958 (Vol 105A, p. 554).
- 5 C.C.I.T.T. Directives, concerning the protection of telecommunications lines against harmful effects from electricity lines.

# Transit-Trunk-Network Signalling Systems

## Part 1—Multi-Frequency Inter-Register Signalling

C. B. MILLER and W. J. MURRAY†

U.D.C. 621.395.34:625.395.38:621.395.74

*The use of a separate transit trunk network permits subscriber-trunk-dialling traffic to be routed over multiple-link connexions. Routing trunk traffic over such a transit network has necessitated the design of line-signalling systems for the different types of line plant likely to be encountered, and a multi-frequency signalling system to enable high-speed signalling methods to be employed between originating controlling-registers and intermediate or incoming terminal-registers. Parts 1 and 2 of this article describe the multi-frequency signalling system developed for use on the transit trunk network, and Part 3 will describe the various types of line signalling system used.*

### INTRODUCTION

The requirements of the transit trunk network<sup>1</sup> defined, in outline, the principles to be adopted for setting up transit-trunk-network calls. The most favourable and economic solution calls for the use of line-signalling systems provided on a link-by-link basis for seizure and supervisory purposes, and a separate, fast end-to-end signalling system for the transfer of numerical and information signals between registers, to ensure that setting-up times are kept within acceptable limits. Such a scheme gives flexibility and economy in the use of signalling equipment, permitting the utilization of line-signalling equipment most appropriate to the line plant available.

In associating the numerical signalling equipment with the register, storage must be provided at the outgoing end of a trunk connexion for the subscriber-dialled digits and for the conversion of these digits into some coded form before presentation for high-speed transmission over the trunk network. Likewise, coded digits received over the trunk network must be stored and processed at each intermediate transit exchange before the call can be extended forward, and, at an incoming group switching centre (g.s.c.), before loop-disconnect pulses can be extended to control the stepping of exchange selector equipment. As the inter-register signalling equipment is only required during the setting-up of a call, it may be provided as common exchange equipment and used on a shared basis. With such a signalling system, the sequence of signals for the transfer of information between the register equipment at each end of the network commences on the application of a demand signal from the incoming end. It is arranged that a limited number of digits are sent en bloc in response to a signal from a transit switching centre (t.s.c.) and on a one-digit-at-a-time basis in response to a different demand signal from an incoming terminal centre. This switching method is preferred to that of awaiting the receipt of the last digit from the subscriber before sending any numerical information forward, as it allows faster setting-up times to be achieved with less complex register-translator equipment at the outgoing controlling end.

The inter-register signalling system for the transit network was required to be capable of operating with existing designs of originating controlling-register equipment installed at

g.s.c.s.<sup>2</sup> The control system employed by these registers considerably influenced the type of signalling code adopted, as the duration of all signals was required to be restricted to ensure that the C.C.I.T.T.\* recommendation for mean power loading per speech channel, allocated for signalling and contributed to by the line and inter-register signalling systems, should not exceed 36 milliwatt-seconds for each direction of transmission during the busy hour.

Other major factors which affected the choice of signalling code were the large transient voltages, with attendant decay characteristics, that are present on the transmission paths as a result of unsequenced operation of exchange switching equipment and of microphony occurring in a random manner as a result of intermittent discontinuity of selector wiper-to-bank contacts. The presence of these types of interference on the transmission paths necessitated the incorporation, in both the signalling code and the equipment, of measures to prevent the simulation of signals and to minimize errors arising from the mutilation of genuine signals.

### OUTLINE OF TRANSIT-NETWORK SIGNALLING ARRANGEMENTS

The general arrangement of the equipment involved in setting-up a transit-network call is shown in Fig. 1. The switching and signalling equipment at an outgoing g.s.c., a t.s.c., and an incoming terminal switching centre are connected to the transmission paths as shown. Association of the inter-register signalling equipment at the outgoing g.s.c. is on a 2-wire basis, with the inter-register signalling equipment in a common pool and access to the controlling register-translator equipment obtained via a finder or hunter circuit when required.

At the t.s.c.s and incoming g.s.c.s the line-signalling equipment extends the 4-wire line to incoming register equipment for inter-register signalling to take place. During inter-register signalling the 2-wire speech path at the outgoing end is disconnected in the register-access relay-set. This obviates the necessity to include guard circuits in the signalling receivers to cope with signal simulation by speech frequencies, and permits the use of a less complex design of receiving equipment with shorter signal-recognition times.

The subscriber-dialled digits (the second and subsequent digits of the national number of the wanted subscriber) are received by the controlling register-translator. On receipt of the requisite number of digits in the register store, the translator determines the metering rate required. For a multi-link

† Mr. Miller is in the Exchange Equipment and Customer Station Apparatus Design and Coordination Branch, Telecommunications Development Department, Telecommunications Headquarters. Mr. Murray is in the Datal, Telex and Telegraph Systems Planning and Provision Branch, Network Planning Department, Telecommunications Headquarters.

\* C.C.I.T.T.—International Telegraph and Telephone Consultative Committee

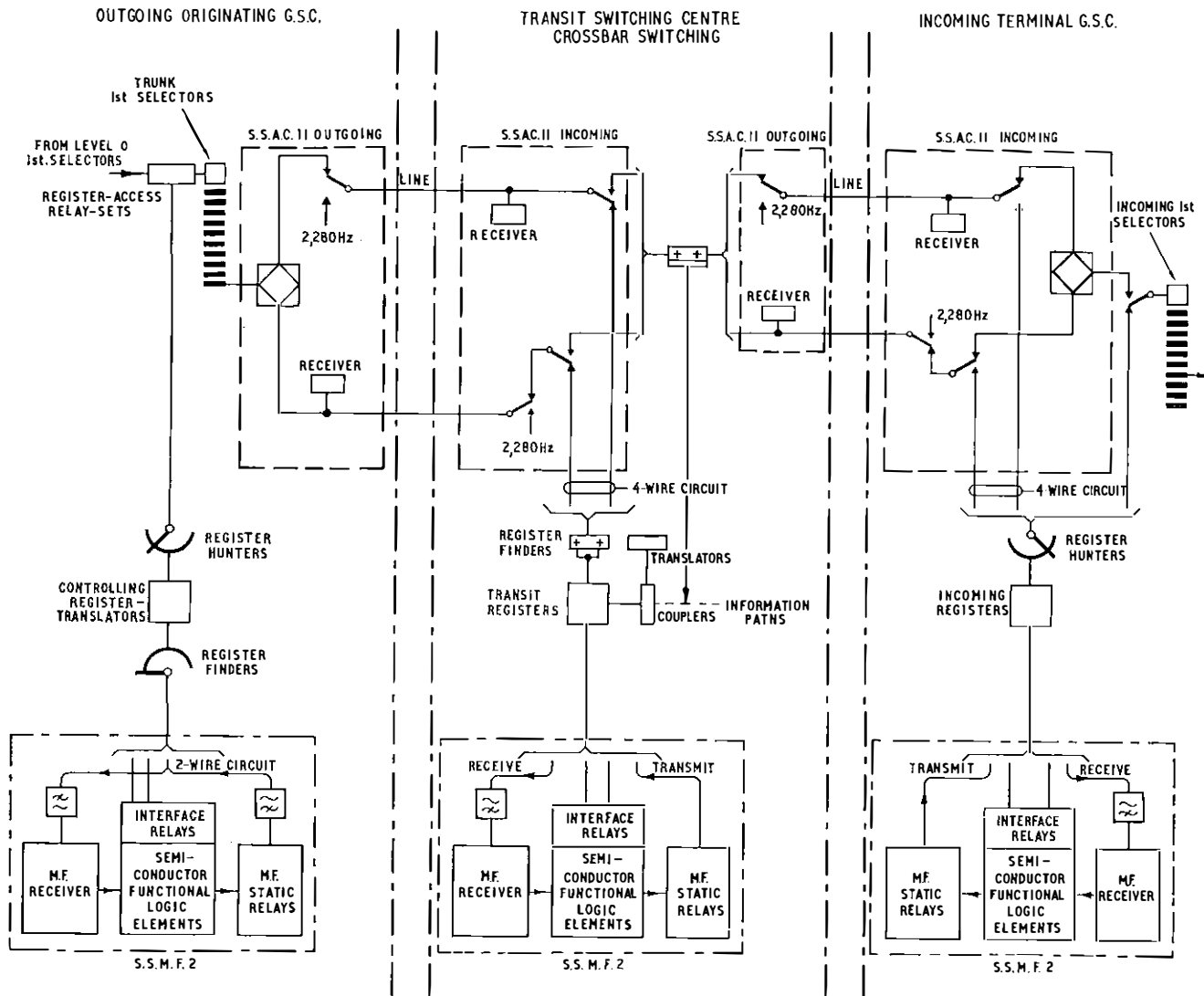

FIG. 1—Transit-network signalling and switching arrangements

transit-network call, the register associates itself with the inter-register signalling equipment and also provides own-exchange routing information to direct the call to an outgoing line-signalling termination on the required transit route.

Seizure of the incoming line-signalling termination at the t.s.c. results in the association of a free register and its inter-register signalling equipment. Signalling commences with the transmission of a continuous backward signal on association of the incoming inter-register signalling equipment. In response to this signal, three routing digits are forwarded en bloc to the t.s.c. The incoming register-translator stores and processes the received digits to route the call through the t.s.c. on a 4-wire-switched basis. When an outgoing line circuit on the required route to the next t.s.c. has been found, the register and inter-register signalling equipment at the first t.s.c. are dissociated from the call in the incoming line-signalling termination, and the 4-wire line is connected through to the outgoing circuit. The call can, if necessary, be similarly processed through a total of four t.s.c.s.

At the incoming terminal centre a different initial signal is transmitted backward over the network from the inter-register signalling equipment, under the control of the incoming register after its seizure by the incoming line relay-set. In response, the controlling register transmits the appropriate code digit forward. After recognition and storage of this digit in the incoming register, a further demand signal is sent to the controlling register, which, on recognition of this

backward signal, sends a further code digit or a numerical digit. In response to further backward request signals initiated by the incoming register, the remaining digital information is sent forward on a one-digit-at-a-time basis from the controlling register.

When the incoming terminal register has received all the wanted digits, a state-of-connexion signal is sent back to indicate that inter-register signalling has been completed. The controlling register receiving such a signal frees the inter-register signalling equipment for use on other calls and dissociates itself from the access relay-set, which extends the calling subscriber through to the established speech path to the incoming terminal exchange. On completion of sending the numerical digits, the incoming-terminal register disconnects itself from the incoming-line signalling termination and connects the called subscriber through to the calling subscriber via the established trunk connexion.

During the call, supervision is catered for by the line-signalling systems individual to each link of the connexion. When the calling party clears, a release signal is repeated forward from line system to line system, each system releasing independently.

#### INTER-REGISTER SIGNALLING SYSTEM

A multi-frequency (m.f.) signalling system was selected for the inter-register signalling system on the transit trunk network to permit high-speed signalling in both directions simultaneously over a network designed to acceptable standards for

speech transmission. In defining the operating parameters for the m.f. signalling system, it was necessary to establish the attenuation/frequency characteristics, the group-delay characteristics and the overall loss variations with time which might occur on switched connexions comprising up to five links in tandem routed over different types of line plant. It was also necessary to incorporate in the system a means to detect errors or loss of signals due to intermittent discontinuities on the line-transmission paths during signalling sequences.

The inter-register signalling system described in the following paragraphs is designated Signalling System, Multi-Frequency, No. 2 (S.S.M.F.2).

### Signalling Code

In the S.S.M.F.2, each signal comprises two frequencies sent simultaneously in what is usually referred to as a 2-out-of- $N$  code, where  $N$  is the number of frequencies used to provide the required number of discrete signal combinations. The signalling code is arranged so that each numerical and information signal in code form is represented by a pulse nominally of 80ms duration. The signalling code is arranged so that each numerical or information signal is preceded by a prefix or guard signal comprising two frequencies applied either continuously or as a pulse nominally of 80 ms duration with the transition from prefix to numerical or information signal taking place without any gap in the transmission.

In principle, the system functions so that a forward and backward prefix signal must be recognized as discrete signalling conditions persisting for a specified period of time before the m.f. receiver is conditioned to respond to any following digit or information signal. Once the m.f. receiver has recognized a digit or information signal, further operation is prevented until the m.f. receiver is restored to normal. This mode of operation eliminates the necessity for sequenced switching of exchange equipment during the association of the m.f. equipment with the line and register, and minimizes failures and error conditions, occurring after association, due to interference in the form of high-voltage transients which simulate m.f. signals or cause errors by mutilation of the m.f. signals.

### Frequency Allocation

The frequencies used for m.f. signalling have been confined to the range 500–2,000 Hz to prevent interference with in-band line-signalling systems using frequencies above 2,000 Hz, and to avoid the need to design the m.f. signalling receiver to cope with the higher attenuation and group delay at the lower end of the audio range. Two groups of six frequencies at 120 Hz intervals, with a gap of 240 Hz between each group, provide for a total of 15 discrete 2-frequency signals in each direction of transmission over the links interconnecting the centres. The frequency coding and the direction to which each group of frequencies has been allocated relative to the outgoing g.s.c. is shown in Table 1.

**TABLE 1**  
**Multi-Frequency Allocation**

Signal Number	Frequency Code	Frequency Combinations (Hz)	
		Forward-Direction Signals	Backward-Direction Signals
1	$f_1 + f_2$	1,380 + 1,500	1,140 + 1,020
2	$f_1 + f_3$	1,380 + 1,620	1,140 + 900
3	$f_2 + f_3$	1,500 + 1,620	1,020 + 900
4	$f_1 + f_4$	1,380 + 1,740	1,140 + 780
5	$f_2 + f_4$	1,500 + 1,740	1,020 + 780
6	$f_3 + f_4$	1,620 + 1,740	900 + 780
7	$f_1 + f_5$	1,380 + 1,860	1,140 + 660
8	$f_2 + f_5$	1,500 + 1,860	1,020 + 660
9	$f_3 + f_5$	1,620 + 1,860	900 + 660
10	$f_4 + f_5$	1,740 + 1,860	780 + 660
11	$f_1 + f_6$	1,380 + 1,980	1,140 + 540
12	$f_2 + f_6$	1,500 + 1,980	1,020 + 540
13	$f_3 + f_6$	1,620 + 1,980	900 + 540
14	$f_4 + f_6$	1,740 + 1,980	780 + 540
15	$f_5 + f_6$	1,860 + 1,980	660 + 540

### Forward-Direction Signals

Six frequencies,  $f_1$ – $f_6$ , in the range 1,380–1,980 Hz provide for the forward-direction signals. The decimal digits 1 to 0 are represented by the signals numbered 1 to 10, respectively. Successive pulses representing a sequence of digits are separated by a pulse of the forward-prefix signal (No. 14). The additional forward signals listed in Table 2 give information relating to the type of outgoing exchange and the type of subscriber's line; this information is required for operator-control purposes, and the signals are only transmitted to the incoming terminal centre in response to a received send-class-of-service signal. Present designs of registers are not capable of marking-in all the signalling conditions necessary to transmit each of the class-of-service signals listed in Table 2. It is intended, however, that future designs will make use of the extended range of signals available.

### Backward-Direction Signals

Initially, five frequencies,  $f_1$  to  $f_5$ , in the range 660–1,140 Hz have been provided for the backward-direction signals. The design of the incoming m.f. sender and receiver is such that the circuits required to cater for the frequency  $f_6$  (540 Hz) may be added at a later date. Table 3 details the allocation of the 2-frequency combinations to cover the requirements for demand acknowledgement and state-of-connexion signals. Transit switching centres are only equipped to send the transit proceed-to-send and congestion signals, each being preceded by a continuous backward-prefix signal. The signals sent from present designs of incoming terminal centres will comprise the terminal proceed-to-send number received (n.r.) and spare code signals. The first terminal proceed-to-send signal is preceded by a continuous prefix signal, and all subsequent

**TABLE 2**  
**Forward-Direction Signals**

Signalling Condition	Signal No.	Frequency Combinations (Hz)	
Prefix . . . . .	14	1,740 + 1,980	
Class of service			
Existing g.s.c.s	{ General . . . . .	2	1,380 + 1,620
	{ Coin-box subscriber . . . . .	8	1,500 + 1,860
	{ Operator . . . . .	3	1,500 + 1,620
Future g.s.c.s with extended facilities	{ General . . . . .	1	1,380 + 1,500
	{ Coin-box subscriber . . . . .	4	1,380 + 1,740
	{ Operator . . . . .	6	1,620 + 1,740
	{ Trunk offering . . . . .	5	1,500 + 1,740
	{ Reverted call . . . . .	7	1,380 + 1,860

signals by a pulse prefix. The send class-of-service signal is intended for general application with future designs of incoming terminal centres and will be the first backward-direction signal following the sending of the continuous prefix signal from the incoming m.f. equipment. Other signals, shown in Table 3, relate to the called subscriber's line, and the alternative signal designations will be used for future designs of incoming terminal exchanges. The outgoing g.s.c. is capable of recognizing and processing all the signals listed in Table 3.

### SIGNAL-SENDING LEVELS

The signalling frequencies detailed in Table 1 are supplied from a battery-operated dynamotor of the tone-induction pattern. The speed of the dynamotor is electronically controlled so that the frequencies of the tones are within  $\pm 0.25$

**TABLE 3**  
**Backward-Direction Signals**

Signalling Conditions	Signal No.	Frequency Combinations (Hz)
Prefix .. .. .	9	900 + 660
Transit proceed-to-send (Send early digits) .. .. .	3	1,020 + 900
Send class of service .. .. .	1	1,140 + 1,020
Terminal proceed-to-send (send late digit) .. .. .	4	1,140 + 780
Congestion .. .. .	5	1,020 + 780
Called line free (Ordinary) .. .. .	7	1,140 + 660
Called line free (Coin box) .. .. .	10	780 + 660
Called line busy .. .. .	8	1,020 + 660
Spare code (Called line unobtainable) .. .. .	2	1,140 + 900
Number received (Limited facilities) .. .. .	6	900 + 780
Repeat attempt (Secondary signal) .. .. .	3	1,020 + 900

per cent of nominal. A frequency-deviation detector associated with the machine monitors the 1,980 Hz output to give a visual indication of the extent of the deviation and to initiate change-over to a duplicate standby in the event of a deviation that exceeds 5 Hz continuing for a period of 2 seconds.

Each frequency, supplied at an output voltage of 20 volts  $\pm 0.5$  volts, is passed via a tone-supply change-over and control panel before distribution to the equipment racks, where transformers reduce the voltage to 2.3 volts before connexion to the m.f. signalling equipment. Each signal-sending element in the m.f. signalling equipment is provided with a further adjustment to control the level of each frequency applied to the outgoing transmission path to  $-8$  dBm<sub>0</sub>. This level was adopted to comply with the C.C.I.T.T. recommendation for a maximum power level of  $-5$  dBm<sub>0</sub> for any single frequency near 2,000 Hz. Although higher levels are permitted at the lower signalling frequencies, each frequency is restricted to  $-8$  dBm at the 2-wire point of entry to the trunk circuit to give a total mean power level of  $-5$  dBm.

At the outgoing g.s.c. each frequency is sent from the m.f. equipment at  $-7$  dBm, which allows for a loss of 1 dB through the exchange switching equipment to the outgoing line-signalling relay-set containing the 2-wire/4-wire termination.

At the t.s.c. and incoming terminal centre, where the m.f. equipment is connected to the incoming line at a 4-wire point, each frequency is adjusted to measure  $-11$  dBm at the m.f. sender output, which allows for up to 1 dB loss between the m.f. equipment and the transmit path of the 4-wire circuit.

### SIGNALLING SEQUENCES

The signal sequences provided by the signal code are shown in Fig. 2. Inter-register signalling commences with the sending of a continuous backward-prefix signal from the t.s.c. following the application of a seizure signal to the m.f. signalling

equipment by the associated register. At the outgoing end the backward-prefix signal must be recognised by the outgoing-end receiver as a discrete 2-frequency signal persisting for a nominal 20 ms period before it is considered as genuine. A continuous forward-prefix signal is then applied as acknowledgement. Recognition of an acknowledging forward-prefix signal as a discrete signal of two frequencies, persisting for 20 ms, indicates that association of the switching equipment has been completed and the transmission path in both directions is satisfactory for the transmission of digital and information signals. The backward-prefix signal is then replaced without any gap in the transmission by a transit proceed-to-send signal applied as a pulse nominally of 80 ms duration. On detecting the cessation of the backward-prefix signal the m.f. receiver is conditioned to respond to the transit proceed-to-send signal. On recognition of this signal, a d.c. signal is sent to the outgoing controlling register to commence the sending of a group of digits known as the ABC routing digits, each digit signal being interspaced by a pulse of the prefix signal, nominally of 80 ms duration.

The use of the prefix signal between each digit signal permits the m.f. receiver output stages to be inhibited after recognition of each digit and to remain so until a subsequent digit requires to be stored. This prevents false operation of the m.f. receiver to transient voltage conditions appearing between digit signals. At the t.s.c., as each digit is received, it is passed forward to the associated register as a pulse of fixed duration marked in a coded form on two out of six leads.

If congestion occurs at the t.s.c., due to non-availability of equipment or outgoing circuits, an 80 ms pulse of the congestion signal will be returned to the outgoing end after an exchange of the continuous prefix signals. Clear-down of equipment at the t.s.c. and the outgoing g.s.c. will follow, and the controlling s.t.d. register initiates a second attempt to complete the call.

On association of the register and m.f. equipment at an incoming terminal switching centre, a similar interchange of continuous prefix signals takes place over the network prior to the sending of a pulse of the terminal proceed-to-send signal from present designs of incoming terminal centres. On recognition of the terminal proceed-to-send signal, the m.f. equipment at the outgoing end requests the register to mark-in the C digit (the B digit in the case of calls to the London director area) for transmission over the network. On recognition of the digit at the incoming end it is passed to the register as d.c. signals marked in coded form on two out of five signalling leads. After checking the validity of the signals the register resets the m.f. equipment and connects a marking signal to cause a further terminal proceed-to-send signal to be sent. However, after the first terminal proceed-to-send signal the continuous prefix interchange is dispensed with and both the outgoing and incoming terminal m.f. equipments are programmed to send the remaining signals as two-element pulse signals. Each pulse is nominally of 80 ms duration and each signal in both directions comprises a pulse of prefix signal followed without any gap in transmission by a pulse of the digit or information signal.

Signal interchanges continue as described above until the incoming register advises the m.f. equipment to send a terminating state-of-connexion signal, i.e. n.r. or spare-code signal. On completion of sending the state-of-connexion signal, the incoming register and the m.f. equipment are dissociated from the network and the incoming trunk line is extended to the terminal equipment by the line-signalling relay-set.

At the outgoing-end, recognition by the m.f. equipment of any of the state-of-connexion signals shown in Table 3 results in clear-down of the register and the freeing of the m.f. equipment for use on other calls. If a n.r. signal is received, the calling subscriber is connected through to the outgoing-trunk-line relay-set. The recognition of a spare-code signal results in the application of number-unobtainable tone from the register-access relay-set to the caller's line.



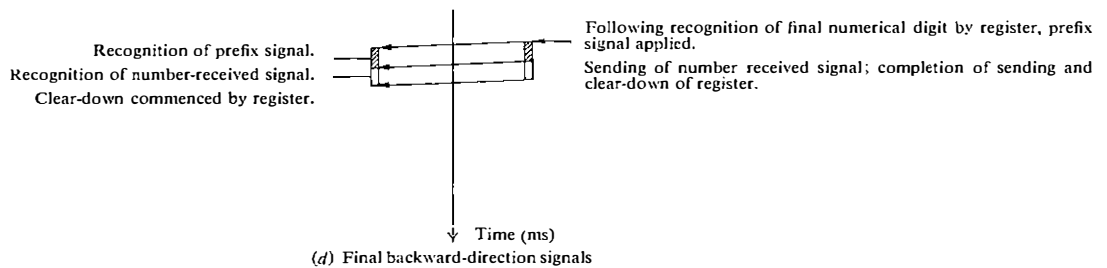
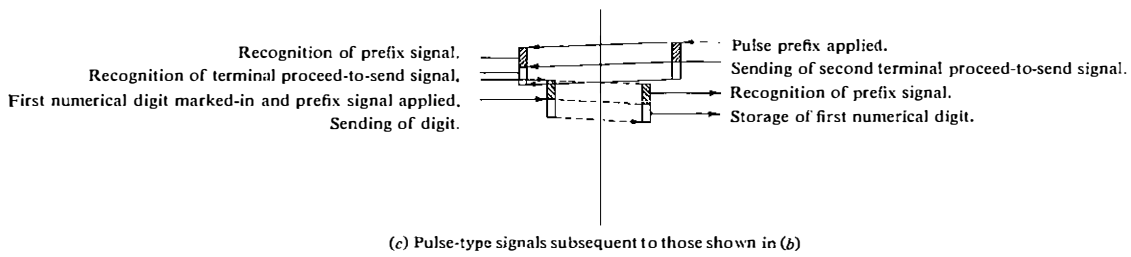
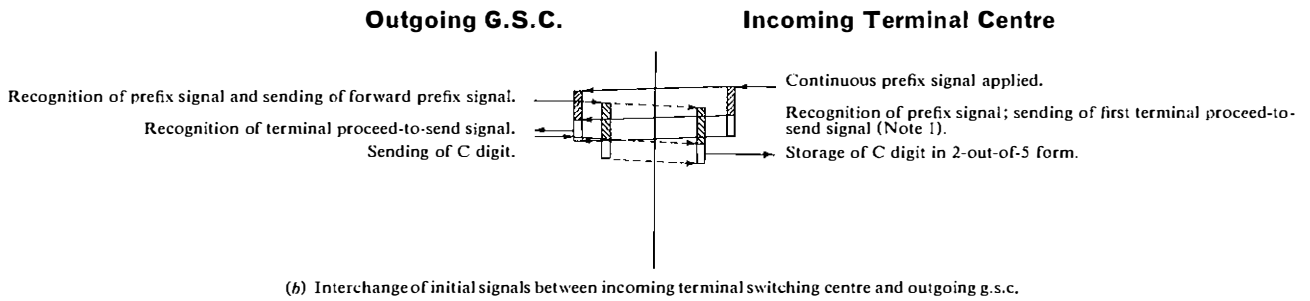
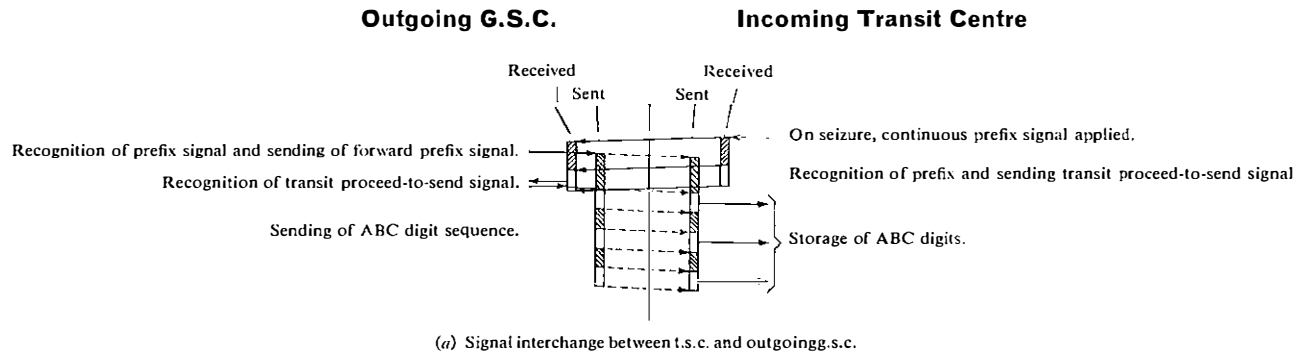

- Notes: 1. In future designs of incoming terminal switching centres, the first backward-direction signal is send class of service  
 2. All digital and information signals are transmitted as 80ms pulses  
 3. Hatching indicates prefix signals  
 4. Vertical line represents time in ms.

FIG. 2—Signal sequences of S.S.M.F.2 signal code

In future designs of incoming terminal centres, the first backward signal following the interchange of the continuous prefix signals will be a send-class-of-service signal, and, in response, the m.f. equipment at the outgoing end will forward the appropriate class-of-service signal marked-in from the outgoing register. The following first terminal proceed-to-send or send-late-digit signal will also be preceded by an interchange of continuous prefix signals, but the second terminal proceed-to-send signal and subsequent signals will be in the

form of 2-element pulse signals. Where provided at new incoming terminal centres, the additional information signals shown in Table 3 will be sent in response to marking-in signals from the register.

#### INTER-REGISTER SIGNALLING EQUIPMENT

The inter-register signalling equipment comprises the m.f. signal-sending equipment and the m.f. signal-receiving equipment, each provided with d.c. logic elements as shown

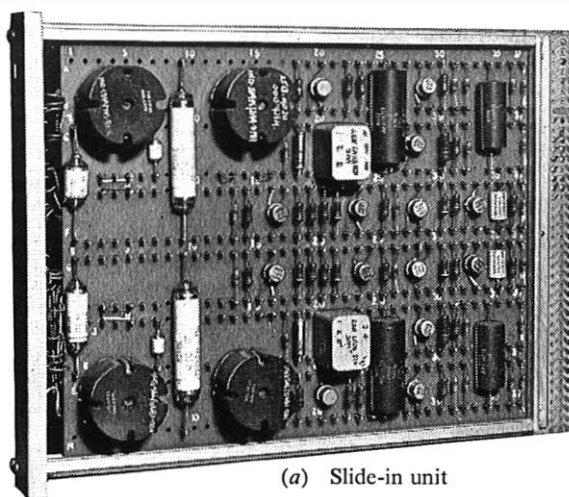

(a) Slide-in unit

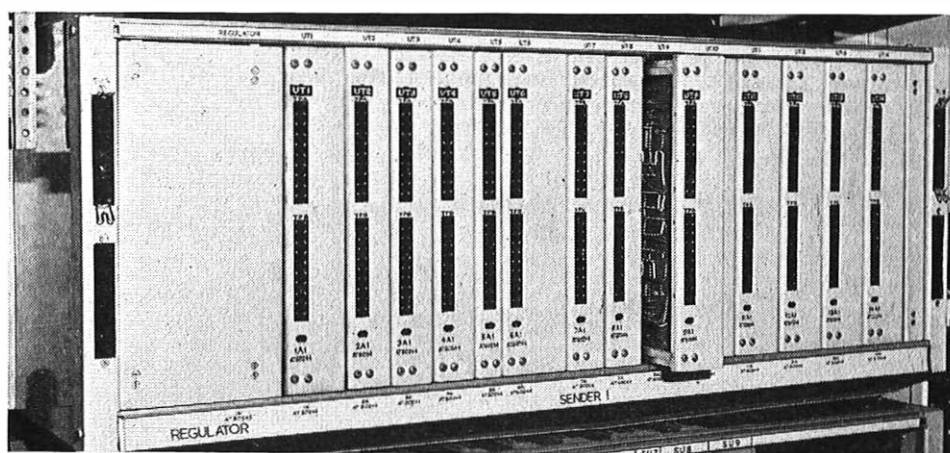

(b) Equipment shelf

FIG. 3—Multi-frequency signalling equipment

in Fig. 1. The separate units are combined together to form one equipment referred to as a m.f. sender and receiver. Interchange circuits form the interface between the controlling register and m.f. sender and receiver over which d.c. signals are interchanged to control the application and sequence of the sent signals and to extend the received signals to the register. The logic elements control the m.f. receiver operation and the processing of the detected signals. Similar elements associated with the m.f. sender control the application of m.f. signals corresponding to the conditions marked on the signalling leads extended from the register. To avoid spurious voltages present on the signalling leads from entering the m.f. equipment and affecting the operation of transistor circuits, a reed-relay interface has been introduced into each signalling lead.

The outgoing g.s.c. m.f. sender and receiver is considerably more complex than that designed for the t.s.c. and incoming terminal centres, as, in addition to providing for sending and receiving a.c. signals in 2-out-of-6 code, it incorporates logic elements to check the validity of the detected signals, to control the sending of signal sequences marked-in by the associated register and to provide time-out and error control under m.f. signalling failure conditions.

Semiconductor devices utilizing discrete-component techniques are used in the design of the S.S.M.F. 2 equipment.

The a.c. signal amplification and detection equipment is coupled to d.c. switching-logic arrangements which control the functioning of the equipment in an economic manner consistent with minimum redundancy.

#### Mounting Arrangements

The components are assembled on slide-in units (Fig. 3(a)) provided with test points on the front panels to facilitate maintenance. The slide-in units are plug-ended, and runners locate the units in position on the aluminium shelf-assembly so that plugs fit accurately into the rear-mounted sockets. Tags on the socket-outlets provide for the inter-unit wiring and connexion to the cable-terminating connexion strip. Each shelf-assembly (Fig. 3(b)) provides accommodation for one complete inter-register signalling equipment including the power supplies, and is designed for mounting on a standard Strowger-equipment rack 2 ft 9 in wide.

(To be continued)

#### References

- 1 TOBIN, W. J. E. The Signalling and Switching Aspects of the Trunk Transit Network. *P.O.E.E.J.*, Vol. 60, p. 165, Oct. 1967
- 2 BARNARD, A. J., BENSON, D. L., VOGAN, D. H., and WOOD, R. A. Controlling Register-Translators. *P.O.E.E.J.*, Vol. 51, pp. 272, 280 and 291, Jan. 1959.

# Testing the Safety of Leads on Electrical Appliances

V. G. W. WAY

U.D.C. 614.825: 621.317.3

*If the leads of electrical and electronic appliances are not in good electrical condition the user may receive an electric shock. This article describes the design of a tester to determine the state of such leads and how it can be used.*

## INTRODUCTION

In any large undertaking there are many potential hazards which are only prevented from becoming positive dangers by the foresight of those involved. One of these is that of electric shock from the appliances and tools which are connected directly to the mains supply. The electrical safety of an appliance can be checked by examination of the appliance and its lead, but if this is done conscientiously the process can be very time consuming. Time can be saved by making electrical tests with a tester designed specifically for the purpose, to supplement a visual inspection.

## THE LEAD-TESTER

The tester shown in Figs. 1 and 2, has been designed at Dollis Hill for testing the mains leads of appliances and tools which may have a full load current of 13 amp or as little as 10 mA. This tester carries out three distinct tests, which are:

(a) an insulation-resistance test between the line and neutral conductors commoned together and the earth conductor of the appliance (500 volts applied line voltage),

(b) a full-load current measurement to determine the rating of the fuse which should be in the appliance or its plug, and

(c) an earth-current test where at least twice the full-load current is caused to flow in the earth conductor of the lead to

the front panel provides a reading which indicates either a satisfactory or non-satisfactory test enabling the tester to be operated by semi-skilled staff.

## DESIGN CONSIDERATIONS

It is important that any device designed to improve safety should itself be safe. To this end the design was produced with all component parts selected to perform their function with a proper margin.

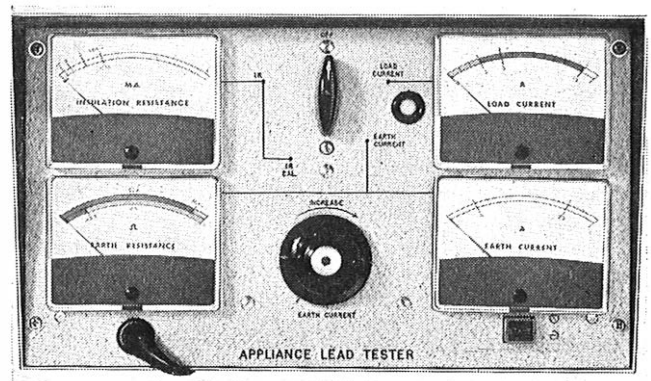

FIG. 2.—Front panel of prototype tester

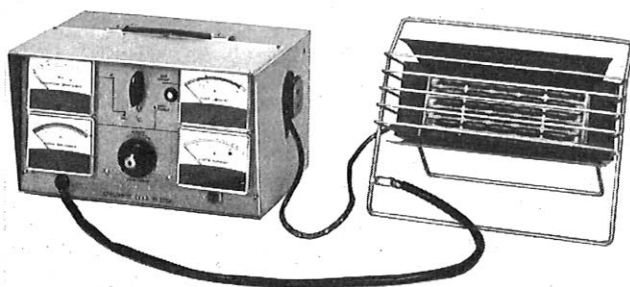

FIG. 1.—Prototype tester being used to test an electric fire.

the casing of the appliance; the resistance between the casing and the earth pin of the appliance plug being measured at the same time.

These tests can be carried out in two minutes by a man who is familiar with the tester, and familiarity can be gained in an hour or so. The design is such that inspection of the meters on

The insulation-resistance test performed by the tester is made at 500 volts. The voltage is applied between the commoned neutral and line conductors and the earth pin of the plug of the appliance. Should a low resistance or short-circuit exist in the lead between these two points, no more than one milli-ampere can flow since this is limited within the tester. No shock can be experienced from the voltage applied because the case of the appliance is permanently connected to the mains earth, via the tester, and also to one end of the secondary winding of the transformer supplying the voltage for the test.

The load-current test is carried out by connecting the mains supply to the appliance through the tester and measuring the current taken by the appliance. The meter used has a 15 amp full-scale deflexion and currents as low as 0.5 amp can be read. Some appliances were found which had an exceptionally low consumption of 0.050 amp and could not be read on the meter. Fitting a range switch to the meter would have increased the number of controls to be operated, hence a lamp which would light when any load current flowed was incorporated. A small transistorized circuit enabled this to operate even when the load current was reduced to 0.010 amp. The value of the fuse required in the appliance plug is given by the next quoted fuse rating which exceeds the meter reading.

The earthing of the appliance is tested by passing a current through the casing and the earth conductor of the lead, to

the earth pin of the plug. The earth current is determined from the value of load current. If the load current is 3 amp, or less, an earth current of 6 amp must be used. If the load current is greater than 3 amp, then the earth current must be 25 amp. The earth current is derived from a mains-isolated transformer at a maximum voltage of 6 volts; this voltage being variable on the mains-input side of the transformer. The voltage is adjusted to give the required current reading and a further meter indicates the value of the earth resistance. Greater than 0.25 ohms was decided on as a bad condition and the meter was scaled accordingly. A timing unit within the tester allows the earth current to flow for one minute, and the timer needs to be allowed to operate to the full extent of its time. A surge of earth current is undesirable, and this is eliminated by micro-switches which operate only when the earth-current control is at zero. A lamp lights in the start button when this condition exists enabling the operator to start the timer and then adjust the earth current.

### TESTING OF DISTRIBUTION-BOARD LEADS

Portable distribution boards which provide multiple outlets from one socket are in common use. A reversal of conductors in these can lead to dangerous conditions. By using a

special lead plugged into the tester and the distribution board a line-earth reversal or line-neutral reversal can be detected in addition to carrying out the insulation resistance and earth current tests already described.

### APPLICATIONS

The tester exists as a prototype which is being used at Dollis Hill and 12 further units are in the process of manufacture for use in research groups. Out of 356 electrical and electronic appliances tested so far, 28 have been found faulty by the tester, the faults being rectified before re-issue of the appliances. The tested appliances have been labelled indicating when the test was made in order that later tests can be carried out after a specified period. It is proposed to change this label to one reading "Not to be used after . . ." with the month and year indicated. This tells the user immediately whether or not a particular appliance is due for retest. It is hoped to establish a system which will ensure all appliances are tested at regular intervals and so reduce the chances of electric shock.

### ACKNOWLEDGEMENTS

The work of Mr. F. J. Scanlan and Mr. R. S. Fuller on the design of this equipment is gratefully acknowledged.

---

## Book Reviews

"Soldering Aluminium." Aluminium Federation. 37 pp. 16 ill. 5s.

This little book sets out the standard techniques for soldering aluminium. The emphasis is practical throughout and, although reasons and explanations are given, the theory is easily understood by an engineer with no specialized knowledge. Aluminium can be soft soldered, plumbed or hard soldered exactly like copper or lead, the only differences being that, in general, temperatures are higher and more active fluxes are needed. A table is given summarizing the various methods and materials available and distinguishing between those which use a flux, those which rely on mechanical abrasion to remove the surface film and those which rely on pre-tinning by plating or spraying. An interesting fluxless method is the use of "friction solder". This is stick solder with an abrasive constituent and it is rubbed on the aluminium to scratch the surface film and effect tinning. Unfortunately, the only soldering method which is attractive for terminating telephone wires—flux-cored solder—is not well represented in the aluminium field. Only one such solder is listed and it is pointed out that it needs a very hot soldering iron. This confirms Post Office experience.

Information is given about fabrication and repair of aluminium items and there are detailed instructions for jointing power cables with aluminium conductors and sheaths.

A list of manufacturers of solders and fluxes is included and the book would appear to be very useful to engineers concerned with aluminium soldering. To Post Office engineers its main value is as a concise and authoritative source of background information.

J. O. C.

"Radio Meteorology." B. R. Bean and E. J. Dutton. Constable and Co., Ltd. viii+435 pp. 254 ill. 26s. 6d.

The excellent text of this book needs no introduction to those concerned with radio propagation, as it has been available since 1966 as National Bureau of Standards (N.B.S.) Monograph 92. This most welcome paper-back edition is an unabridged and corrected re-publication of the earlier volume which brought together the work done in radio meteorology over the previous ten years at the N.B.S. Central Radio Propagation Laboratory. That decade, and the years since have seen a great increase in interest in the effects of the lower atmosphere on radio propagation and the text does much to give an appreciation and understanding of these effects. For those not already familiar with the book the text contains chapters on the radio refractive index of air, the measurement of the radio refractive index, tropospheric refraction, N-climatology, synoptic radio-meteorology and applications of tropospheric refraction and refractive index models. Additional chapters cover transhorizon radio-meteorological parameters and the attenuation of radio waves by atmospheric gases, clouds, rain, hail and fog. This last chapter is particularly useful in view of the current interest in exploitation of frequency bands lying above 10 GHz for radio-relay systems. The final chapter of the text contains radio meteorological charts, graphs, tables and sample computations.

For the newcomer to the field this book is an invaluable introduction and hardly to be ignored at the price, and even those who know it well, but have not already done so, may be tempted to acquire a personal copy.

D. T.

# Notes and Comments

## New Year Honours

The Board of Editors offers congratulations to the following engineers honoured by Her Majesty the Queen in the New Year Honours List:

Wales and Border Counties .. ..	G. Jackson .. ..	Regional Engineer ..	Officer of the Most Excellent Order of the British Empire
Research Department .. ..	S. Marsden .. ..	Senior Executive Engineer	Member of the Most Excellent Order of the British Empire
London Telecommunications Region	W. H. Slater .. ..	Assistant Executive Engineer	Member of the Most Excellent Order of the British Empire
London Telecommunications Region	A. A. Barnes .. ..	Technical Officer .. ..	British Empire Medal

## E. W. Ayers, B.Sc.(Eng), F.I.E.E.

Recently appointed to a new Deputy Director post in Research Department, Eric Ayers has, since his previous appointment in 1964, been involved in the Empress p.c.m. experiment and in customer-equipment and human-factors work. Lately, he has extended integrated-systems thinking towards the customer, guiding pioneer studies in broad-band distribution of a range of audio and visual, message and entertainment services.

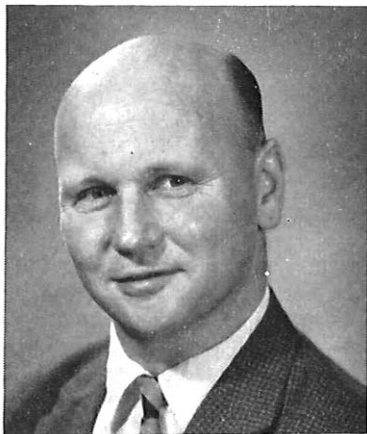

Now his responsibilities cover all aspects of Research Department work on customer services in telephony, data and visual communications. His vast energy, his lively appreciation of developments in electronics, and of the opportunities and needs for new services, and his practical engineering judgement are applied in a wider context, as is his capacity for pithy and vigorous speaking and writing.

We wish him well in his work. May he also have leisure to continue his photography and cinematography to the delight, and envy, of his friends.

H. B. L.

## K. A. Hannant, B.Sc.(Tech.), C.Eng., M.I.E.E.

After 18 years on engineering work at Area, Regional and Headquarters level and 2 years as a Staff Engineer on computer work in Management Services Department, Keith Hannant took charge at Christmas last of the External Telecommunications Services with the rank of Regional Director. He brings to his new job a wide and unique experience. His knowledge of equipment and network planning will be particularly valuable in services expanding as rapidly as are the overseas telecommunications services. He joined the Post



Office at Liverpool in 1950 as an Executive Engineer and, after a spell in Regional headquarters, came to Headquarters in 1958 as S.E.E. In 1965 he was promoted A.S.E. in OCG Branch and became Staff Engineer in MSD in December 1967. From September 1966 he provided professional technical advice on the drafting of the Bill setting up the new Post Office. During his 2 years in MSD he built up an efficient team with a professional outlook to develop the computer system which will be required to aid management in providing an effective telecommunications service for the '70s. His personal qualities and his ability to get on with people and to get them to work with him should ensure for him the success we wish him in his new appointment.

R. E. J.

**J. F. P. Thomas, B.Sc., C.Eng., M.I.E.E.**

The appointment of Mr. Thomas as Deputy Regional Director (Service), LTR, will be welcomed by his many friends within the Post Office and in the Telecommunications Industry.



Seven years ago he became the Assistant Staff Engineer in LMP Branch (Engineering Department), responsible for planning the inland trunk network. In 1966 he was appointed Staff Engineer in charge of the branch, which became part of the THQ Network Planning Department on reorganization of the Post Office, with added responsibility for planning and providing the radio microwave network. Frank Thomas entered the Post Office Engineering Department at Dollis Hill Research Station as a Youth-in-Training in 1937. He became a probationary Inspector in 1942, and obtained his London B.Sc. (Hons.) degree after studying at Northampton Engineering College. From 1948, as an Executive Engineer, and from 1957, as a Senior Executive Engineer, he was engaged on submarine-cable system work, which contributed to the success of the first Transatlantic Telephone Cable project (TAT 1). His responsibilities since 1963 have covered a period of great expansion of the inland trunk network, but his breezy personality and perpetual good humour have enabled him to carry this heavy load with distinction. His colleagues and friends are convinced that he will achieve similar success in his new field of responsibility.

L. W. J. C.

**H. Thwaite, B.Sc.(Eng), M.I.E.E., C.Eng.**



Henry Thwaite's well merited promotion to Staff Engineer will be endorsed by his many friends. He entered the P.O. at Keighley, Bradford Area as a Youth-in-Training in 1933 and four years later saw him promoted to Inspector and engaged

on Trunking and Exchange Power Development in the old Tp Branch. Five years commissioned war time service at home and abroad with the Fleet Air Arm was followed by promotion to E.E. on Exchange Maintenance and later promotion to S.E.E. in the old S Branch. Here he carried out a number of duties but will undoubtedly be best remembered for his pioneer work on the application of transistors in the subscribers' apparatus field and, in particular, the deaf-aid handset, range of loudspeaking telephones, conference amplifiers and aids for the disabled, including the first transistorized National Health hearing aid. One development now coming to fruition which has been an especial interest to him is the behind-the-ear aid for children.

Always an individual and never one to accept bald statements unquestioned, Henry Thwaite brings to all his tasks a versatile, alert and enquiring mind allied to a refreshing, no nonsense, down-to-earth approach which will assuredly stand him in good stead in his new position as head of the newly formed TD11. He will carry with him a multitude of best wishes.

T. C. H.

**P. T. F. Kelly, B.Sc.(Eng.), C.Eng., M.I.E.E.**

After a couple of years spent in the elevated surroundings of central government Phil Kelly has returned to THQ as Staff Engineer of the new Data Systems Planning Branch. He brings to his new post the ideal combination of a broad knowledge of communications (mostly with a "transmission" slant) and a keen appreciation of computers—their shortcomings as well as their vast possibilities.

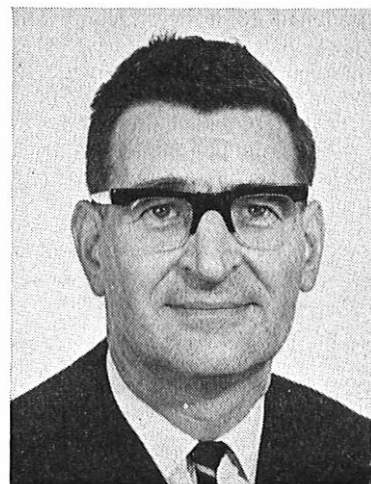

After several years experience on training, Phil Kelly joined the Lines Branch Laboratory in 1950. Through the 50s and early 60s he was mainly involved (as an E.E. and later an S.E.E.) in submarine-cable systems both to Europe and to the New World. He was, in fact, one of the early transatlantic commuters.

Awarded a Nuffield Travelling Fellowship in 1964 he spent ten months in Sweden and Canada studying the organisation of long-distance telecommunications. Many of the recommendations he made as a result of this experience have been introduced into Post Office practice. On his return to the Post Office—now as an A.S.E.—he immersed himself eagerly in the application of computers to engineering problems, first those with a "lines" flavour but later broadening into the wider fields of exchange equipment and maintenance.

This experience fitted him ideally for the next phase of his career, which he spent as an Assistant Secretary in charge of the Computer Division, first at the Treasury and later in the Civil Service Department; here he controlled and advised upon the broad aspects of computer usage in government departments.

Outside official hours Phil Kelly still takes an active interest in rugby football (which he stopped playing only recently): he is a member of the Surrey County R.F.C. Committee. To this, and all his many other outside activities, he brings his well known gifts of enthusiasm and good humour; we are all glad to see him back and wish him well.

C. A. M.

**D. J. Withers, C.Eng., M.I.E.E.**

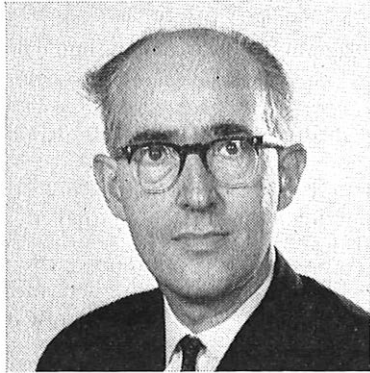

David Withers' Post Office career has been linked throughout with the planning of overseas radio services. It began in 1948 when he joined the old WP Branch (h.f. radio planning and provision) as an Assistant Engineer by Open Competition and continued as an Executive Engineer (Limited Competition) when he became a founder member of the Engineering Branch of E.T.E. in 1952 and later as an S.E.E. in the same Branch.

Promotion to A.S.E. in 1965 took him to WS Branch (Space Systems) and there he turned his extensive knowledge of radio propagation and system planning to good effect in planning for new satellite systems to be provided by INTELSAT. When the increasing load on the branch led to the division of its function into two branches it was no surprise to his colleagues that David was promoted to Staff Engineer in charge of all Space Segment Planning. In addition to his extensive knowledge and experience he brings to the job a great capacity for hard work, quiet humour and a penetrating mind. We all wish him well and feel sure that he will make a success in his new post.

R. E. G. B.

**P. R. Bray, Ph.D., M.Sc.(Eng.), C.Eng., F.I.E.E., M.B.I.M.**



The announcement of Phil Bray's promotion to be Controller (Director of Studies) in THQ may have concealed from his many friends the fact that he continues to be Principal

of the Technical Training College at Stone. The elevation of this post—announced by the Deputy Chairman when opening the first of the new buildings of the College last September—is an indication of the growth and development of the College and it will be gratifying to all that Phil Bray will remain at the helm during this important stage of its life.

After graduating with Honours at Queen Mary College in 1932 and post-graduate work on Hysteresis in Rotating Magnetic Fields leading to a M.Sc. Degree in 1934, he first acquired experience with manufacturers before joining the Post Office Research Branch in 1935. There followed widening experience in Research Branch, in the Cable Test Section of Test and Inspection Branch and in H.M.T.S. *Monarch*, and in particular valuable work in connection with the manufacture and acceptance of cable for the first trans-Atlantic telephone cable system. Whilst engaged on this work he presented a thesis on Fault Localisation on Long Submarine Cables at Sub-Audio Frequencies, resulting in the award of his Ph.D. in 1956.

Phil Bray has been Principal of the Technical Training College since 1965 and to the load has added considerable professional service as Chairman of the I.E.E. North Staffs. Sub-Centre Committee, as a member of the I.E.E. Recruitment Panel, and as President of the Associate Section of the I.P.O.E.E.

It is indeed fortunate that the Technical Training College will continue to benefit from his considerable experience and academic distinction and his colleagues wish him every success in this important field.

M. M.

**E. H. Pooley, C.Eng., F.I.E.E.**

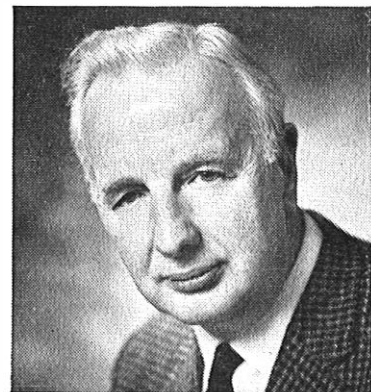

Eric Pooley's promotion to Controller Planning and Works (External), Midlands Telecommunications Region has been generally acclaimed as a case of "a round peg in a round hole".

For a considerable part of his career he has been concerned with external planning and works with a more than passing interest in transmission systems which now together form the major part of his load.

Starting in Chelmsford in 1927 as a Youth-in-Training, he moved in 1930 to Rugby Radio Station. Three years later he was successful in the Probationary Inspector's Competition and after his "indoctrination" at the Dollis Hill Training School was posted to his home town, Cambridge. In 1938 he moved to Bedford on promotion to Chief Inspector where he was closely associated with the Air Ministry Communications Centre at Leighton Buzzard and with Eastern Command Signals. In 1950 he made his first acquaintanceship with the Midlands when he became Area Engineer in Nottingham. Since his promotion in 1965 to Regional Engineer Midlands he has been well to the fore in initiating a number of new external practices and methods, now adopted nationally.

His wide experience and sound common sense, coupled with his helpful and considerate personality will ensure the successes in his new post that his many friends wish him.

J. W. R.

**R. H. Adams, C.Eng., M.I.E.E.**



Bill Adams' appointment as Planning Controller, Eastern Telecommunications Region will give pleasure to his many friends in THQ and the Regions.

From 1939 to 1946 he served as a Marine Radio Officer in the Merchant Navy. Subsequently he spent a year as a Radio Officer in civil aircraft followed by a short period with the Ministry of Civil Aviation.

He entered the Post Office as an Assistant Engineer in 1948 and was concerned with the development of wide band and magnetic amplifiers and the associated test equipment for television links.

In 1952 he was appointed Executive Engineer after success in the Limited Competition. He then moved to East Area LTR, and controlled a staff planning and executing external works. He was promoted S.E.E. in 1962 and moved to the then OC Branch of the Engineering Department (E.D.). This appointment was concerned with the complementing and organisation of the E.D. branches, the technical aspects of PRU investigations for major engineering, motor transport and submarine staff. In 1965 he was promoted A.S.E. in OCG Branch E.D. and continued with work of a similar nature. He moved to E.T.R. in 1968 and until his new appointment was Regional Engineer responsible for the planning and execution of main and local lines, transmission and telegraphs works.

His quiet efficiency and friendly and approachable nature assure success in his new duties. His many friends wish him well.

S. T. E. K.

**Model Answer Books**

Books of model answers to certain of the City and Guilds of London Institute examinations in telecommunications are published by the Board of Editors. Details of the books available are always given at the end of the Supplement to the Journal.

**Notes for Authors**

Authors are reminded that some notes are available to help them prepare the manuscripts of the Journal articles in a way that will assist in securing uniformity of presentation, simplify the work of the Journal's printer and draughtsmen,

and help ensure that authors' wishes are easily interpreted. Any author preparing an article for the Journal who is not already in possession of the notes is asked to write to the Managing Editor to obtain a copy.

It is emphasized that all contributions to the Journal, including those for Regional Notes and Associate Section Notes, must be typed, with double spacing between lines, on one side only of each sheet of paper.

Each circuit diagram or sketch should be drawn on a separate sheet of paper; neat sketches are all that are required. Photographs should be clear and sharply focused. Prints should preferably be glossy and should be unmounted, any notes or captions being written on a separate sheet of paper. Negatives or plates are not needed and should not be supplied.

**Circulation of the Post Office Electrical Engineers' Journal**

The Board of Editors is pleased to note the continuing increase in the circulation of the Journal as shown by the following statistics.

Journal Issue	Number of Copies Printed
Vol. 62, Part 1, Apr. 1969	35,800
Vol. 62, Part 2, July 1969	36,300
Vol. 62, Part 3, Oct. 1969	36,600
Vol. 62, Part 4, Jan. 1970	37,000

Approximately 10 per cent of the Journals are sold to overseas readers in more than 50 countries.

**Supplement**

Students studying for City and Guilds of London Institute examinations in telecommunications are reminded that the Supplement to the Journal includes model answers to examination questions set in all the subjects of the Telecommunication Technicians' Course. Back numbers of the Journal are available in limited quantities only, and students are urged to place a regular order for the Journal to ensure that they keep informed of current developments in telecommunications and receive all copies of the Supplement.

**Syllabuses and Copies of Question Papers for the Telecommunication Technicians' Course**

The syllabuses and copies of question papers set for examinations of the Telecommunication Technicians' Course of the City and Guilds of London Institute are not sold by *The Post Office Electrical Engineers' Journal*. They should be purchased from the Department of Technology, City and Guilds of London Institute, 76 Portland Place, London, W.1.

**Publication of Correspondence**

The Board of Editors would like to publish correspondence on engineering or technical aspects of articles published in the Journal.

Letters of sufficient interest will be published under "Notes and Comments". Correspondents should note that, as it is necessary to send copy to the printer well before publication date, it will only be possible to consider letters for publication in the July issue if they are received before 15 May 1970.

Letters intended for publication should be sent to the Managing Editor, P.O.E.E. Journal, Room 264, 207 Old St, London E.C.1.



**Letter to the Editor**

Dear Sir,

I note with some satisfaction that the Journal is now prepared to support a "Letters to the Editor" section, for I am sure this is a useful move, which may well lead to some interesting correspondence. Whether the following comments can be placed in the interesting category I am not too sure, but they may serve a purpose in redirecting thought.

I wish to refer to Fig. 2 in Messrs. Thain and Wells' article "Improving Underground Maintenance—Part 1—The Investigation", in the January 1970 issue. Apparently, from this diagram, the authors determine that some, if not all, Areas have a continuously deteriorating local-underground-plant fault rate. It is rather unfortunate that this derives from drawing a best-fit line, calculated on a least squares basis, and labelling it *trend line*, for the statistical purist, I believe, would call this the *regression line* and would not use it to determine trends.

I would not wish to argue over much with Thain and Wells, for their present endeavours in the field continue to be of utmost value, and, irrespective of the statistical treatment adopted, there is little doubt that the fault rate is much worse than it used to be. I would suggest, however, that a different treatment might lead to a more correct approach to the problems involved.

A more satisfactory method of determining trend is to plot the exponentially-weighted moving average and I have carried out this operation for the figures given in their Fig. 2. This shows that from mid-1962 to early 1965 there was no significant trend either way. From early 1965 to mid-1966 there is a most definite upward trend, and then after 1966 the trend again becomes of little significance.

I have operated similarly on a number of Area charts covering this period and this 1964-5-6 upward drive is nearly always evident, in some in a more marked fashion than in others. That for lengthy periods there is no significance in the trend can be checked by other methods, one such being described on Duckworth's "A Guide to Operational Research," p. 144 of the University Paperbacks edition.

This new look suggests that whilst local underground fault rates may fluctuate wildly over the years from a multitude of different reasons, at specific periods in time one significant change becomes effective, probably a change in plant type, or constructional method, which lifts the whole curve to a new position.

It would seem that effort should be concentrated on the determination of these significant factors rather than deploying it thinly over a number of minor aspects.

Without doubt something came to full effect in the 1964-5-6 period which has cost a considerable additional annual expense, for it is as well to remember that a lift of only 0.2 in the fault rate represents an additional maintenance burden

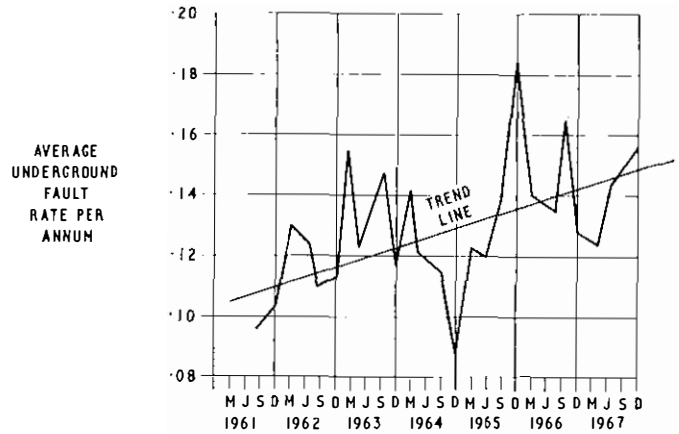

(a) As published originally showing trend line

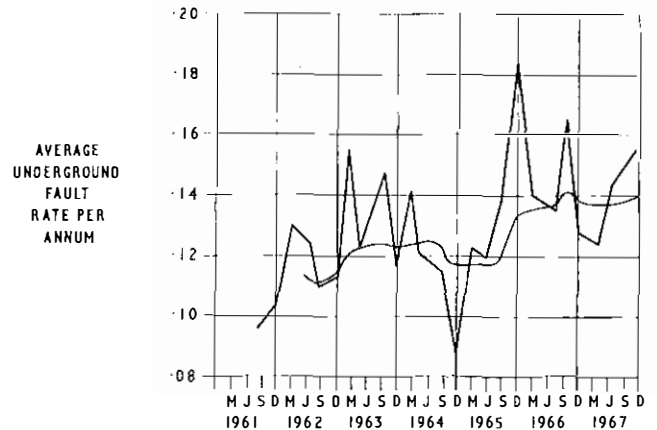

(b) Redrawn, showing exponentially-weighted moving average

Average UG fault reports per working underground pair per annum plotted quarterly for one area only

of some 1,600,000 manhours (and, in money terms, something in excess of £1,500,000 a year).

Dare I suggest this is the penalty accruing from the culmination of the change to directly-buried polythene cable on housing estates (Thain tells us 95 per cent of all cable defects occur in the smaller cables) which was justified on a basis of saving £500,000 annually in initial costs. Or has anyone other theories?

Yours sincerely,

A. F. G. ALLAN

Customer's Maintenance Service Branch,  
Service Department,  
Telecommunications Headquarters.

# Institution of Post Office Electrical Engineers

## Associate Section Papers Awards, 1968-69

The I.P.O.E.E. Council, on the adjudication of the Judging Committee, has awarded prizes and Institution Certificates to the following in respect of the papers named:

*First Prize of £7 7s.*

D. Ashton, Technical Officer, Sheffield Centre. "Emergency Motorway Telephones".

*Prizes of £4 4s.*

G. S. Steer, Technical Officer, Exeter Centre. "Talking Books for the Blind".

D. A. Frith, Technical Officer, Grantham Centre. "Microwave Repeater Stations".

K. F. Wood, Senior Technician, Lincoln Centre. "Circles, Clocks, Calendars and Computers".

F. J. Brown, Technical Officer, Exeter Centre. "The Work of a Voluntary Ambulance Driver".

The additional prize of one guinea was awarded in respect of the paper shown below which was considered by the Local Centre Committee to be worthy of submission to the Judging Committee for the main awards:

N. H. B. West, Technical Officer, Exeter Centre. "Model Engineering".

The Council is indebted to Messrs. C. A. L. Nicholls, O.B.E. C. D. S. G. Robertson and B. J. Woollett for kindly undertaking the adjudication of the papers submitted for consideration.

The Council of the Institution is indebted to Mr. B. J. Woollett for the following report on the award winning papers:

*"Emergency Motorway Telephones", by D. Ashton*

This paper is a comprehensive statement on the problems of providing motorway emergency telephones. It is a well-balanced, readable paper. It describes the system in general and then proceeds logically to explain how it works at the motorway roadside-cabinets and at the control station ends. The paper also covers maintenance aspects and the problem of inductive interference from 50 Hz power lines. Anyone involved in providing or maintaining P.O. motorway systems will find this paper informative and useful.

*"Talking Books for the Blind", by G. S. Steer*

This author reminds us that less than 20 per cent of blind people are able to read by means of Braille and even then at speeds rarely above 80 words/min. The author explains how talking books have evolved with the progress made in electrical recording.

The author is well qualified as a volunteer who installs and maintains the talking book machines, to describe the advantages to the user of this progress. The paper is a very clear account of how technology has helped blind people. The

author ends by saying that it is a constant source of pleasure to him that the P.O. conveys tape cassettes to and from the library by post free of charge to blind people.

*"Microwave Repeater Stations", by D. A. Frith*

This paper is mainly a descriptive account of the various pieces of apparatus that go together to make a microwave repeater station. The author claims that this paper is not theoretical or highly technical. It is therefore acceptable to the reader who wishes to know what a microwave repeater is, rather than how it works. The paper has many simple and clear diagrams. The paper ought have been enhanced by the author giving the reader a more general account of the problems of microwave transmission before dealing with the various equipments that comprise a basic repeater station.

*"Circles—Clocks, Calendars, Computers", by K. F. Wood*

Although the paper has no telecommunication content, it is informative and would appeal to the person with interests in either astronomy or archaeology. The author poses the question whether later Stone Age Man was capable of building stone circles as calendars and computers. The paper then gives the views of several experts as to whether Stonehenge can answer this question. The views of the experts differ. The author ends with his own opinion and suggests how further research might proceed.

*"The Work of the Voluntary St. John Ambulance Driver", by F. J. Brown*

This is a non-technical paper, but is probably interesting to people, especially those who live in less populous parts, and where essential services such as Fire and Ambulance are largely maintained by part-time volunteers.

The paper gives a very vivid account of the author's personal experience as a volunteer ambulance driver; it also gives an interesting account of some of the equipment ambulances carry to meet all kinds of emergency. The paper is written in a narrative form and holds the reader's interest well.

*"Model Engineering", by N. H. B. West*

The author of this paper is obviously a keen model engineer. His paper advocates that the model engineer must be proficient in the whole process from design, pattern making, moulding, casting and such like, to toolmaking, painting and lining. The paper covers several of these processes. The author explains what made him interested in model engineering; he also covers acquiring tools and choosing models. On this latter point he relents a little and admits there are plenty of drawings and castings available to make steam engines at least for beginners. The paper leaves one in no doubt that model engineering is a dedicated hobby.

A. B. WHERRY

*General Secretary*

# Regional Notes

## North-Western Telecommunications Region

### *Access to the Winter Hill Radio Station*

When the Independent Television Authority (I.T.A.) mast at Emley Moor in Yorkshire collapsed last winter, doubts were raised about the safety of its twin, the 1,000 ft mast at Winter Hill in Lancashire. As a precaution, the I.T.A. instituted stringent safety measures at the latter site. The mast has been fitted with strain gauges and their output is integrated with the readings of anemometers so that under conditions of possible danger warning lights are illuminated on the perimeter of the danger area. Unfortunately, the only access road to the Post Office radio station on Winter Hill passes within the area at risk, and the land surrounding the road is treacherous peat bog.

As soon as the problem was recognized the Blackburn Telephone Area plotted the best available route over the moorland out of the danger area to give access from the Post Office station to the road lower down the hill. This track was marked out with tall stakes and bridges were constructed over several deep gullies using telephone poles and arms. This work was carried out during the summer and it was intended that the regional "Snowcat" normally stationed at Preston, should be used to evacuate Post Office staff over the escape route during prolonged warning periods. However, when the wet autumn weather arrived the versatile "Snowcat" was very nearly lost when it sank in the bog to a depth of several feet.

About this time it became evident that the problem produced by the mast would exist for a prolonged period, possibly several years, and so a more permanent solution was needed. Consideration was given to the loan of a helicopter, but this was not pursued because, under the severe weather conditions experienced in the area, flying would often be impossible and the various masts on the hill would constitute serious flying hazards.

The problem has now been partially solved by the purchase of a small six-wheeled amphibious vehicle known as an "Amphicat". This type of vehicle, which is made in Canada, has been used on Antarctic expeditions and is used in Canada for negotiating rivers and lakes, etc.

Its six tyres are inflated to an air pressure of  $1\frac{1}{2}$  lb/in<sup>2</sup> and they give traction under all normal conditions and also provide additional buoyancy in water. In water, propulsion is obtained by the paddle action of the treads moulded into the tyres. An "Amphicat" is stationed at the end of the escape route where the maintenance officer is located so that staff can always be got in or out of the station when a danger condition is indicated.

The restricted carrying capacity of the vehicle makes it suitable for getting two or possibly three persons in or out of the station in emergency only. As a further safeguard, beds and increased hard rations have been stored on site, and survival kits for 10 men have been purchased to enable an evacuation on foot to be undertaken with reasonable safety.



The "Amphicat" alongside the Winter Hill I.T.A. mast.

During warning periods the British Broadcasting Corporation and I.T.A. staffs are completely evacuated from the transmitter buildings, and programs are monitored from caravans placed at a safe distance. Similarly, the Post Office apparatus room in the transmitter building is evacuated during these periods, and local failures cannot be attended to until the warning is terminated. The Post Office radio station however, carries television and telephony channels between Manchester and Carlisle as well as the South Lancs Radiophone equipment, and access to these may be required quite independently of the local transmitter.

The only satisfactory long-term solution to this problem may be an alternative road which, owing to the nature of the terrain, would be both difficult and costly to construct. The illustration shows the "Amphicat" near one of the warning signs outside the Post Office radio station with the I.T.A. mast in the background.

At the time of writing, alarms are occurring almost daily and often several times in one day. In general they seldom last for more than about 30 minutes, but during one period of bad weather the alarms were continuous for nearly 36 hours.

K. J. SANSBURY

## South-Eastern Telecommunications Region

### *New Generating Sets at Reading Trunk Exchange*

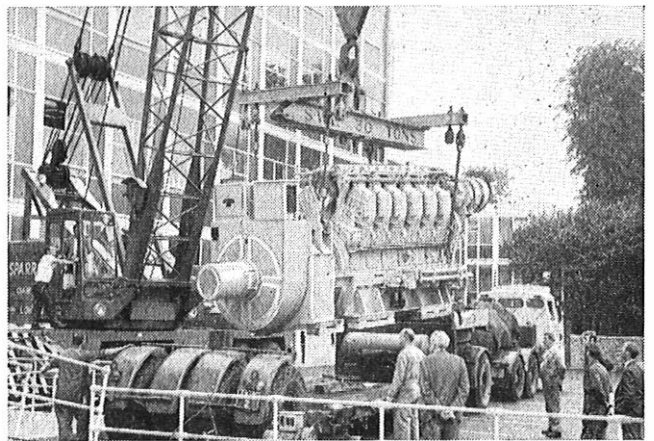

Diesel-engine generating set being lifted from transporter.

The relative calm of Reading Trunk Exchange was disturbed on Thursday, 11 September 1969, when the car park was occupied for the day by large transport vehicles and a mobile crane. The occasion was the delivery of two 1-MW diesel engine generating sets forming part of the new power supply equipment.

Each set weighed between 20 and 25 tons and had to be lowered into a pit about 15 ft deep and then inched into the building on rollers. The lowering process was accomplished with deceptive ease but, due to an oversight in not providing boiler plates across the Engine Room floor, the first set got bogged down at the entrance by the collapse of the floor tiling. Remedial action took several hours, but this experience illustrates strongly the need for extreme care in moving heavy plant within buildings if damage to floor surfaces is to be avoided.

E. A. INGRAM

## London Postal Region

### *Retubing of Hot-Water Boilers*

Two La Mont oil-fired medium-pressure hot-water boilers of 9,500,000 BThU capacity have been retubed by London Postal Region engineers without previous experience in this type of operation.

Each boiler contains 79 tube elements and all passed at first attempt the tests required by the Factories Act.

J. A. BLACKBURN

## Northern Ireland

### Time Consistent Traffic Recording: Automatic Stop Facility

With time-consistent traffic recording, accuracy of the starting time need not be better than within a few minutes either way of the specified time. It is, however, absolutely essential that the record should be stopped after precisely 100 cycles.

Pending provision of automatic starting and stopping facilities on all traffic recorders, a cheap and simple means of automatically terminating records has been provided on traffic recorders of various types at eleven exchanges in the Northern Ireland directorate.

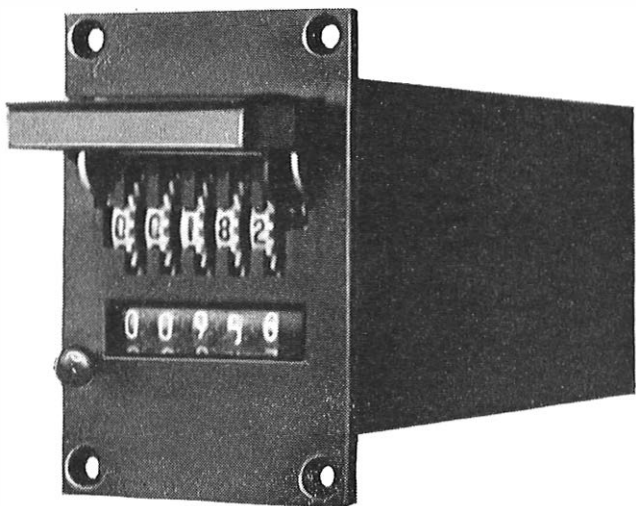

FIG. 1—Electric predetermining counter.

The device (Fig. 1) consists of a counter which can be set to break the start circuit of a recorder after any number of cycles. It includes an electrically-operated counting mechanism (bottom set of numbers), a bank of wheels (top set of numbers) on which the desired number of cycles is set, and a control switch which opens when the pre-determined number of cycles has been completed. A reset feature is also provided which can be either manual or electrical for remote control.

In Northern Ireland the equipment has been mounted on a bracket fitted to the traffic-recorder control rack, an aperture of  $1\frac{3}{4}$  in  $\times$   $2\frac{3}{4}$  in being required, and connected in parallel with the test-cycle meter, as shown in the circuit diagram (Fig. 2).

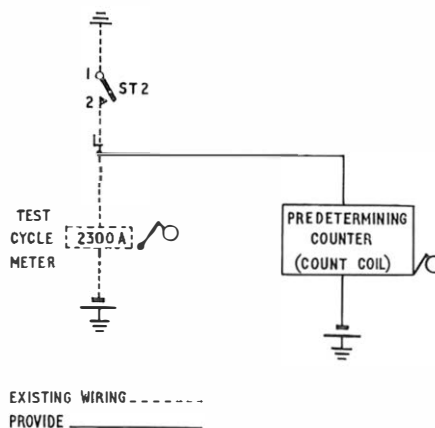

FIG. 2—Connexion of counter to traffic recorder.

The operating voltage is 50 volts d.c. The equipment has been working satisfactorily for about three months. The total cost per item, including installation (by Post Office labour) is about £15.

W. H. FARMER

## Associate Section Notes

### Hereford Centre

The annual general meeting was held at the Spread Eagle Hotel, on 3 December 1969, and was followed by a steak supper.

The following officers were elected:

*Chairman:* Mr. S. J. Cound; *Vice Chairman:* Mr. T. W. Wellington; *Secretary:* Mr. C. J. T. Brace; *Assistant Secretary/Librarian:* Mr. K. Lee; *Treasurer:* Mr. L. J. Knight; *Auditors:* Messrs. W. J. Merrick and M. Powell; *Committee:* Messrs. J. Bethell, F. Dykes, L. Higgins, M. Frost, N. Innes, H. Holt, D. W. Cleaton, L. Evans, P. Williams, C. Morris, R. Fairclough and F. Neate.

The membership totals 125 and the section is quite active with 3 visits and 3 lectures during the session. Four talks have been provisionally arranged for 1970, they are: "Food and Cooking" by a local gourmet, "Principles of Crossbar Exchanges", "P.C.M." and "Cable Construction" all by Post Office staff.

Visits have to be finalized but it is hoped that they will be as interesting and informative as last years.

C. J. T. B.

### London Centre

The 1969-70 session began with the Centre under new chairmanship following the resignation of Mr. A. G. Welling. The new top table now comprises *Chairman:* Mr. F. R. Pitcher; *Secretary:* Mr. A. J. Dow; *Treasurer:* Mr. R. A. Gray; *Assistant Secretary:* Mr. P. D. M. Southgate; *Vice Chairman:* Mr. J. J. A. Gutteridge; *Editor:* Mr. B. E. Bolton and *Registrar:* Mr. D. Randall.

The lecture program started with a talk on P.C.M. and this was followed in October by Mr. F. T. Booth's excellent discussion of Satellite Communications. On 5 November Mr. Thain from Management Services Department treated us to a study of the jointer. More correctly one was given an insight into the work study methods as used by the Post Office. The potential of the jointing machine devised by research stemming from the study was illustrated.

December was a chance for the Hi-Fi experts and they were not disappointed. The New Year opened with Mr. D. A. Spurgin's formal lecture on telecommunications power plant and that was followed in February by a talk on the National Data Processing Service. For March, London attracted Mr. E. E. Scott from the R.A.E. who marvelled all with the talk entitled "50 Years of Flying".

Before all this yet another party of members had taken advantage of the good terms offered by the Centre to visit the U.S.A. and Canada and again returned delighted.

The New Quarterly Journal presented a commemorative issue on 1st October to mark Vesting Day and the Editor and the journal continue to press on optimistically.

London scored in another way when last November the West Area quiz team, winners of the 1969 regional trophy, took on the South-Eastern champions, Canterbury, at Camel-ford House. In one of the most exciting contests for many years West Area won by a slender margin and restored the Trophy, a model of the Tower, to the capital.

The area organization is as yet far from perfect but none the less satisfactory bearing in mind the size of the Centre and the numbers involved.

B. E. B.

### **Aberdeen Centre**

The Aberdeen Associate Centre began the 1969-70 session with a visit to the Glenfiddich distillery in Dufftown on 24 September. The party travelled from Aberdeen by bus and were shown the distillery in the afternoon.

On Wednesday 22 October one of our members, Mr. J. Davidson, gave a talk entitled "The Growth of the Trawl Fishing Industry". This talk was very well received, the subject being of special interest in this area. To follow Mr. Davidson's talk an evening visit to the Department of Agriculture and Fisheries Marine Laboratory was arranged for Thursday 20 November.

On the 11 December the speaker was Mr. W. Sheldon, the Deputy Telephone Manager of Edinburgh Area, whose talk was entitled "Transit Switching." Mr. Sheldon's talk was of particular interest to his audience because of the transit exchange being installed in Aberdeen at this moment.

One of our members, Mr. A. Young, has won awards by Plessey and Radio Spares Limited for coming first in the City and Guild examination in Line Transmission C.

R. M.

### **Ayr Centre**

In April, a talk on the Transit Network was given by Mr. W. Sheldon of T.H.Q. Scotland. This well-attended meeting was one of the highlights of the session, and we welcomed members from places as far distant as Greenock and Stranraer as well as Ardrossan and Kilmarnock. Mr. Sheldon's talk was very well received and much useful knowledge was gained on the subject. The annual general meeting was held in June when, amongst other matters, the program for the present session was discussed.

The 1969-70 session opened in October with a visit to see the organ of Trinity Church, Ayr. This fine 3-manual pipe organ, demonstrated by an enthusiastic organist, combined to make a very interesting evening. Slides were shown, mostly of the history of organs in general and, for our special interest, most of the pipework was in view. The electrical registration control by means of banks of solenoids was of special interest to our members.

A. B.

### **Bournemouth Centre**

This Section, after a busy summer session, intends to have a relatively quiet winter program.

Recently 12 of our members had a very interesting tour of Poole Power Station.

During the next three or four months it is hoped to arrange a film show or two and possibly lectures in association with other local associations. This will depend on the support we get from members. Support during the winter months in the past has been very poor. Already we are making arrangements for the summer 1970 and any ideas members may have would be very welcome.

H. J. G.

### **Dundee Centre**

Our session got off to a rather slow start, but things are beginning to look up now.

The first lecture was about the Backwater Reservoir in nearby Glen Isla. This is an earth dam and all the problems encountered were adequately explained and illustrated with a full quota of slides.

The annual film show listed "The Post Office Tower", "Antarctic Crossing" and "Two Laps of Honour". The films were excellent and worth recommending.

1970 starts with a talk on Integrated Circuit Manufacture, followed by P.A.B.X. No. 6, Decimalisation, and a visit to Barr and Stroud, Glasgow.

R. T. L.

### **Edinburgh Centre**

On Thursday, 9 October 36 members visited Spadeadam Rocket Establishment in Northumberland where we saw the

various workshops and testing area where Rolls-Royce and Hawker Siddeley developed the "Blue Streak" rocket. This was a most interesting visit, the only disappointment was that we were unable to see an actual test fire.

On 2 December we had a very good visit to Ferranti Ltd. Fifteen members attended, and since the Ferranti personnel were all communication engineers this made it a very interesting evening.

M. K. F.

### **Inverness Centre**

The 1969-70 session is now well under way and, for the first time, membership of the Inverness Centre exceeds 200.

Our first meeting, held in October, was "The Changing Face of Inverness". Mr. J. Herrick, Assistant Burgh Surveyor was the speaker. His talk was illustrated with old maps and prints and the plans for future developments within the burgh.

At our November meeting, Mr. J. Y. Lilley, Assistant Executive Engineer, External Planning, was the speaker. His subject was "Local Line Planning and Development in Housing Estates". Using plans of the Town Council estate at Hilton and the private estate at Balloch, Mr. Lilley described the different methods used to provide external plant to houses during building, and how plant had been designed to meet the needs of large underground distribution networks.

At our December meeting, Mr. R. I. Thomson, vice chairman was projectionist at a film show held in Cummings Hotel on Wednesday, 17 December. Thirty-nine members and guests were present to see films on sailing, golf, pigeon shooting and "better dawns". The Centre is indebted to Mr. Thomson for his hard work in connexion with the film show and for bringing along his projector and gear.

W. A. A.

### **Oxford Centre**

Our winter program has started well with good attendances at interesting events.

In October a party visited Didcot Power Station where we saw turbines and generators under assembly.

During the following month we visited the Royal Observer Corps, who showed us a film and spoke on their purpose and how they use the lines and equipment that the Post Office provides.

Our last event of 1969 was a talk on Police Communications, their methods of moving into action quickly, their liaison with the Post Office and the equipment they use.

We have arranged for the coming months talks on automatic exchanges, space research, a Hi-Fi demonstration, an inter-Centre landline quiz and an "Any Questions" with the Area Board.

For dates and further information contact the Secretary.

D. A. G.

### **Sheffield Centre**

On the 23 and 30 September two parties from Sheffield, each comprising some 20 members, visited the Post Office Tower in London. The main attraction of these visits was that participants were allowed access to many parts of the building not normally open to the general public.

On 17 November Mr. P. Wade of Regional Headquarters presented a paper at Eldon House entitled "S.T.D., the Next Step". 30 members and visitors attended.

The Centre Chairman, Mr. J. Buckley also presented a paper entitled "Protection in the Post Office" and this is a subject on which he, as an underground planner, is particularly knowledgeable.

The Committee extend their congratulations to Mr. David Ashton, our Secretary, on winning 2nd prize in the N.E.R. Journal Shield Competition. His paper was entitled "Emergency Motorway Telephones".

T. D.

# Press Notices

## Directories by Computer Production Begins this Month

The world's most advanced method of producing telephone directories came into full operation in January with completion of the first directory by a new, completely integrated computer printing process developed jointly by the Post Office and Her Majesty's Stationery Office (H.M.S.O.)

The method employs computers to select, arrange and edit directory entries, and modern high-speed photo-composing processes for setting, before giant rotary presses take over to print from photo-polymer plates and the job is completed by an automatic gatherer-binder-trimmer machine. These new production methods will provide more up-to-date and more accurate directories for customers and will also give the directory-enquiry services more efficient records from which to work.

First directory to be produced by this advanced method was for the Stoke-on-Trent area and the Post Office started distributing this before the end of January. New directories for Preston and Blackburn will follow on closely and other directories will soon be rolling off the new production line.

The stage-by-stage system begins in the Post Office with telecommunications staff entering customers' directory entries on cards in a ready form for punching and computer processing.

The Post Office's National Data Processing Service (NDPS) gathers the information daily from Telephone Managers' offices all over the country at its Leeds computer centre. When the time comes to produce a new edition of a telephone directory the complete list of numbers with names and addresses and information on how each should be printed is selected by this computer and recorded on magnetic tape.

This is sent to H.M.S.O.'s computer at Norwich which edits the information and converts it on to punched paper tape with typographical instructions.

From this punched paper tape the H.M.S.O. plant at Gateshead automatically produces an alphabetical telephone directory page by page on a photo-composing machine at a rate of four minutes a page. The pages are photographed nine at a time and from the negative are produced plastic covered lightweight wrap-around plates. The plates are directly mounted on rotary presses that can run off 40,000 72-page directory sections in an hour. The sections are brought together to make the full directories on a machine that automatically gathers and trims them and binds them in their cover.

The new method enables the Post Office and H.M.S.O. to prepare a directory from scratch ready for printing in a record time of 45 working hours—a fraction of the time previously taken in working from standing type and making the necessary 25 per cent amendments and alterations that are required every year. At first, the yellow pages of the classified section will continue to be printed separately and brought together with the alphabetical section at the binding stage. But the Post Office is planning to include classified directory production in the new method by 1973. The new method will meet the growing problem of having to produce more and bigger directories year after year as the telephone system continues its rapid expansion. For every 10 per cent increase in the total of telephone subscribers 20 per cent more paper is wanted for directories.

Today there are 22 million copies of telephone directories issued in the United Kingdom every year. These use 25,000 tons of paper. One complete set of directories contains 30,000 pages and 7½ million entries. By 1975 the number of directories issued is expected to rise above 33 million, using 45,000 tons of paper. One complete set will then have about 45,000 pages containing 11 million entries. Cost to the Post Office of producing directories in 1969-70 is £3 million for paper and printing and another £1 million for compiling, transport and delivery.

The Post Office will shortly begin to use the same information to keep every directory-enquiry operator constantly provided with the very latest changes to the lists of telephone numbers which they hold.

## PO Plans Record Graduate Intake

With plans for a record intake of over 700 graduates this year, the Post Office began its 1970 series of recruitment visits to universities in January.

The Post Office is now one of Britain's biggest "shoppers" for graduates, to fill a wide range of professional and management posts as scientists for research, development and planning engineers (electrical, electronic, mechanical) computer systems analysts and programmers, postal and telecommunication managers, statisticians and in other expanding areas of Post Office activity. In 1969, over 600 graduates accepted offers of appointment at management and professional levels of entry. The 1970 intake will come from all kinds of university disciplines including the arts and humanities, but with a preponderance from electrical and electronic engineering, mathematics, physics and related sciences. Opportunities for mechanical engineers are increasing as more and more postal mechanisation schemes are planned and get under way.

In addition to graduates, the Post Office will be seeking to recruit about 600 entrants from polytechnics and technical colleges, as well as promising school leavers with good A levels, for junior management level posts. These entrants will be encouraged to continue further education to degree level.

## Telephone Trunk Circuits increased

New telephone trunk circuits installed by the Post Office in 1969 numbered 10,743. This was 678 more than in 1968. It represents a 14.5 per cent increase on the total number of trunk telephone circuits working in the United Kingdom to 84,603 at December 31, 1969.

## Post Office Launches Datapost

A completely new overnight delivery service for the transmission of computer data and other material is to be launched by the Post Office. Named Datapost, the new service will offer collection and delivery on a door-to-door basis at times and places specified in a contract between Post Offices and sender. It will not be available on a casual basis, only as a regular contractual service, for a minimum of three months.

The charge will vary according to the individual agreement but is expected to be about £2 for a package weighing up to 10 lb. Although designed primarily to cater for the fast-expanding demand for conveying data to and from computer centres Datapost will also handle other material, such as medicines and legal documents. By making use of its country-wide network of rail and road routes the Post Office will be able to collect and deliver material without it ever leaving Post Office hands.

Datapost is expected to capture 10 per cent of an estimated £2 million market within a year, using only existing services and manpower.

## Successful Year with Digital Telephone Exchange

A year's operation of a digital tandem telephone exchange in London has shown that p.c.m. switching of speech channels is feasible, giving improved reliability.

The experimental digital tandem exchange was installed for field trials in the Empress public telephone exchange building in West Kensington in September 1968 and has operated successfully on live traffic ever since.

Measurement of the quality of service indicates that equipment of this type will lead to a considerable improvement over the existing electromechanical exchanges, the number of calls lost being less than 0.1 per cent. The tandem exchange handles approximately 3,000 calls per day; nearly one million connections have now been completed.

Connected to the tandem exchange are three London director exchanges, Acorn, Ealing and Shepherd's Bush, employing routes of between two and six miles. Direct junctions also exist between each pair of these exchanges and the traffic is shared between the direct junctions and the tandem exchange.

The trial demonstrates the feasibility of switching pulse-code-modulated signals on junctions between conventional

Strowger exchanges, and the resulting performance has shown that the switching of speech channels in p.c.m. form is not only feasible but can be achieved with improved reliability.

Maintenance appears to offer no serious problem; the majority of failures so far encountered have been detected by the automatic testers employed to monitor continuously the control logic and the transmission path. By this means virtually the whole exchange is tested every few minutes, day and night, giving a printed record of the few failures found.

The exchange contains approximately 7,000 silicon integrated circuits, with a failure rate of 0.02 per cent per 1,000 hours. The introduction of large-scale integrated circuits into future designs will increase reliability still further.

### **Moon Landings Communications—British Post Office Role Marked by NASA Presentation**

The part played by the British Post Office in the landing of the first men on the moon was marked on December 17 when Mr. Philip French, London station manager for NASA (National Aeronautical and Space Administration), made presentations to Mr. James Gill, Director of External Telecommunications, and two members of his staff who have worked closely with NASA—Mr. Charles Mitchell and Mr. John Crowther.

The Post Office's task in the missions was to provide and operate communication circuits via land line, submarine cable and communication satellite routes. These circuits—carrying speech, vision, high-speed data and telegraph signals—played an important part in the world-wide network linking the manned capsules in space with the space-flight control centre at Houston, Texas.

Two similar NASA awards for communications support in American space exploration have been made to the British Post Office previously. The first was for assistance in the 1965–66 Gemini manned space missions; and the second for support in the Apollo 8 first manned orbit of the moon. The latter award was presented to Mr. Gill in January this year by Colonel Borman, the Apollo 8 commander.

### **London—New York Direct-Dialled Telephone Calls**

Twopence-a-second self-dialled telephone calls from London to New York City will be possible from March 1 with the introduction of the world's first major intercontinental dialled telephone service. At about the same time some subscribers in New York will be able to dial direct to London and other main centres in the United Kingdom.

UK—USA International Subscriber Dialling (ISD) will be extended gradually to other cities in the UK and to other parts of the USA during the next two years. Within the same period the Post Office hopes to introduce the first ISD services to Canada, initially to Montreal and Toronto.

To dial New York from London the code will be 010 1 212 (010 is the ISD code; 1 the country code for America; 212 the area code for New York), followed by the New York City subscriber's exchange and number.

At the same time as London—New York dialling starts, the cost of making telephone calls through the operator to the USA and Canada is to be reduced. Ordinary (number to number) calls will cost 15s a minute (minimum of three minutes) instead of 16s 8d; personal calls will continue to be charged at £4 for the first three minutes but the charge for additional time will be at the new lower rate of 15s a minute. In the reduced-rate period (22 00 to 10 00 hrs and all day Sunday) the ordinary call charge will be 11s 3d a minute (minimum three minutes) instead of 12s 6d; personal calls will still be charged at £3 for the first three minutes and additional time will be charged at 11s 3d a minute.

Also from 1 March there will be cuts in the price of trans-Atlantic telex calls to the USA and Canada, from £1 to 15s. a minute (minimum one minute).

From 1 April there will be reductions of 15–19 per cent in the cost of privately-leased circuits across the Atlantic.

Significant reductions of anything up to 50 per cent will be made in rates for telephone and telex calls to the more distant European countries from 1 March—whether they are dialled or made through an operator. There will, however, be

increases in the cost of telephone calls through operators and of telegrams to some nearer European countries.

Customers will no longer be surcharged for personal or transfer-charge telephone calls to any country if those calls do not succeed.

The Post Office will charge a new flat rate of 1s a word for telegrams to all Continental countries, except the USSR to which the charge will be 1s 4d a word. At present charges vary from 7d to 1s 6d a word.

The new rates, negotiated internationally by the Post Office, are designed to relate charges made to customers more closely to costs and to achieve a more satisfactory balance between costs of automatic services and those that are operator-controlled.

They are also the outcome of Post Office proposals, endorsed by the National Board for Prices and Incomes, "generally to lower oversea tariffs although individual rates may increase."

### **In Half a Year—Nearly Half-a-Million more Telephones**

Nearly half-a-million more telephones were in use in this country on 30 September than six months' earlier. In that period the number of telephones working in the United Kingdom increased by 450,190 to 13,361,962—a 3.5 per cent increase.

### **Office of the Future takes Shape**

Within 20 years many people will be carrying out their day's work without leaving the comfort of home. Taking advantage of advanced telecommunications techniques they will be able to hold meetings, examine documents transmitted from head office, supervise work at factory or construction site, and draw instantly on the most detailed information—all from their favourite chair.

This was demonstrated at an exhibition opened by the Duke of Edinburgh at the Design Centre in the Haymarket, London and organized jointly by the Council of Industrial Design (COID) and the Post Office.

The exhibition illustrates the development of Post Office telecommunication services, showing typical offices of 1909, 1970 and 1990.

The 1990 display shows a civil engineer working from home—making full use of telex, facsimile transmission and visual communication, with instant access to a National Data Processing Service (NDPS) computer.

Among many uses, the computer acts as a central file, from which information can be retrieved instantly, and prepares a work program for the day, rearranging it in the light of unforeseen events.

### **New NDPS Computer Centre for North-East**

A large ICL System 4-70 computer has been installed at the Post Office's new National Data Processing Service centre in Leeds, together with a wide range of peripheral equipment and off-line machines. The centre was opened by the Lord Mayor of Leeds, Ald. A. R. Bretherick.

This powerful third-generation machine marks Post Office progress in using the latest techniques for its many and varied accounting and management problems. It also adds greatly to the computing power at the disposal of business and commercial interests in the North of England. The initial workload will be made up primarily from jobs already developed for the Post Office including computer compilation of telephone directories. Substantial capacity has been set aside for business and industry.

The computer, the most powerful in the System 4 range, was installed at a cost of £800,000. It has a very large core store and a complete range of peripheral equipment, including two high-speed printers, paper-tape readers, and card readers. The data-preparation block is equipped with the most modern card and paper-tape punching and verifying equipment. It also has magnetic tape encoding facilities.

The ICL System 4 operating system allows for high utilisation of the 4-70 processor capacity by multiprogramming with or without the facility of job streaming. Streaming is a pre-determined division of the hardware facilities into convenient sized units. Each stream has its own core-store allocation

and peripherals but uses the central processor, disk units, and to some extent magnetic tapes unit, in common with other streams.

System 4 streaming provides for the computer to be divided into up to six streams, with each stream capable of being operated in parallel with, and without materially affecting other streams, as long as sufficient processor and disk-access time are available to meet all the demands made. A system of streaming has been made for Leeds which is expected to enhance operating efficiency when used in conjunction with related facilities.

The new Leeds computer centre was built at a cost of £850,000 and was designed to allow for expansion. It has two main sections—a data preparation block and a computer block. The computer block includes two computer rooms with movable partitions. False flooring extends beyond the computer rooms to provide for despatch and receipt areas, maintenance areas and tape store; these areas could be used to house further equipment, as needed.

The centre will employ about 250 staff on data-preparation (punched card) work and 15 to 20 on computer operational work. Data preparation will be carried out on a one-shift basis and initially the computer will operate for one shift only. Two-shift working is expected to be introduced in December with a third (night) shift following in 1970.

The ICL 4-70 central processor at Leeds has a 262-kilobyte main core-store, four exchangeable disks, 18 magnetic-tape units, two high-speed printers, two card readers, a paper-tape punch and reader and a card punch. The multi-channel control unit allows the machine to be used with remote terminals making working possible through either video-display units or teletypes.

### **Eight Thousand Million Telephone Calls**

More than eight thousand million telephone calls would be made in this country this year, stated Lord Hall of the Cynon Valley, Chairman of the Post Office, when he opened a new Plessey factory at South Shields.

In making these calls, said Lord Hall, Post Office customers would use the telephone, an instrument worth only a few pounds, to bring into action a multi-million pound technical and engineering complex which would connect a caller to one out of almost 13 million people.

A call from Southampton to Glasgow, for example, would, once it was dialled, pass through 500,000 soldered contacts, 50,000 pressure contacts, 320 relays, 27 mechanisms, 4,000 valves and transistors and 140,000 other components. In setting up the call 8,000 individual contact operations would occur.

Lord Hall commented that there were not many industries to-day forced to digest so rapidly so many technological developments. Certainly there were not so many industries with such an assured future.

This would not represent a ready-filled, no-questions-asked order book. To meet the challenge of the future the Post Office had to be ready to adapt to the changing pressures of demand and of a technology-conscious society. This attitude of mind was vital to the future of the Post Office and of the telecommunications industry.

Lord Hall paid tribute to the manner in which the Post Office, the Plessey Company and the other members of the telecommunications industry had established Britain's lead in the installation of small and medium-sized electronic exchanges.

### **New Research Centre in Suffolk for new Corporation**

An £8 million contract to build a new scientific and technological research centre for telecommunication and postal services has been placed for the Post Office with Mitchell Construction Co., Ltd, of Peterborough.

The new centre, finest of its kind in Europe, will stand on 100 acres of the former Martlesham Heath airfield near Ipswich, Suffolk. Construction begins early this year and is expected to be completed towards the end of 1972. The centre will house the Post Office's Research Department, at present stationed at Dollis Hill in North London, with ample space for expansion and for large-scale field experiments that cannot be attempted at Dollis Hill.

The Martlesham centre will attract graduates to a career in research to provide the best possible telecommunication and postal systems for Britain, maintaining her place as a world leader in the fast-developing global communication system. With a staff of up to 2,000 engineers, scientists and supporting technicians, it will bring increased spending power and new employment opportunities to the Ipswich area. Most of the 1,400 people working at Dollis Hill and its outstations will be moving to Martlesham and about 1,000 new houses will be needed for owner occupation and renting by Post Office staff.

Over 100 people have already moved to Martlesham, working in existing buildings and researching into long-distance waveguide systems and high-capacity submarine cable laying. Another 100 follow in the next few months. The main force will move in 1972 and 1973 in a carefully phased operation, being planned with full staff co-operation.

The half-century since the research station was established has seen the beginning of the communications explosion, with rapid advances in communication techniques—often led by Dollis Hill researches—and a phenomenal growth of demand for new facilities. To stay ahead of every possible development that will make the postal and telecommunication services more efficient, work at Dollis Hill has been expanded until every inch of the crowded station has been pressed into use—and much more space is needed. For this reason the Post Office decided to move its research effort to Martlesham, where spacious modern conditions will give its research workers creative freedom.

Martlesham research centre, designed by the Ministry of Public Building and Works, who placed the building contract, will have a seven-storey main laboratory block with a total floor area of 440,000 sq ft, a five-storey administrative block, and a group of research workshops, drawing offices and stores. The centre will have ample lecture rooms, library and conference facilities. All the research accommodation will be fully air-conditioned. To speed construction, part of the design period has been telescoped into the contract period and Mitchell Construction will work in conjunction with the MPBW architect, Mr. S. Spielrein.

The Post Office is now spending nearly £11 million a year on research and development (of which £4.5 million is for research), in close collaboration with industry and the universities. This compares with £5 million for research and development in 1963-64. Some indication of the expanding range of research that will be undertaken at Martlesham is given by the work now being carried out by the Research Department.

Projects under way include long-distance waveguide systems for 300,000 telephone circuits or 300 two-way television channels; long-life, high-performance transistors; integrated pulse code modulation digital transmission and switching systems; microwave radio-relay and satellite-communications systems above 10 GHz; and automated mail-handling systems. The Research Department is also working on high-capacity submarine cable systems (1,500 circuits); the use of stored-program control and central processors for exchange switching; the application of digital techniques for local distribution; and on conference television (Confravision) and vision telephone (viewphone) developments. Other subjects under study include data transmission at ever-higher speeds; reliability aspects of microelectronic integrated circuits in telecommunications; and human factors in 'phone' vision and data communication.

### **Submarine Cable in Polythene**

The first polythene-covered submarine cable to be laid in Britain's national telephone network is now being connected in Scotland. Joining Ardelve and Flouder Bay, Ross-shire, the new mile-long experimental cable was laid by the cables ship *Iris* across Loch Alsh and will shortly be in full service.

The new cable was developed by the Post Office and manufactured by British Insulated Callender's Cables Ltd. The standard lead sheath has been replaced by polythene, with an aluminium screen. There are 17 armour wires and the conductors are paper-covered. Replacing a 16-core gutta percha cable laid in 1939, the new cable contains 54 pairs of wires, providing spare circuit capacity for future growth. Replacing the lead sheath with polythene has meant a 25 per cent saving in costs—and a 30 per cent weight reduction making the cable easier to lay with small ships.



Loch Alsh is a sea loch and the alternative land route between the Dornie and Glenshiel exchanges would mean an 18-mile detour. Several more short submarine links using the new type of cable are planned for Scotland, and one to join Portsmouth and Gosport, Hants.

Polythene-covered submarine cables previously laid in Britain have been high-frequency coaxial cables for the international telephone network.

### Mondial House: New Telephone Exchange

A new international telephone exchange—largest of its kind in Europe—is to be built in the City of London to cope with the continuing rapid growth of international telephone traffic. The building will cost about £7 million to construct, and will be equipped and in service by 1974–1975. The initial equipment in it will cost about £10 million and more will be added as traffic grows. The equipment will connect United Kingdom telephone subscribers to numbers in all parts of the world; the great majority of calls will be dialled direct by customers. The exchange will also connect calls from abroad to telephones in this country and will route calls between countries in Europe and the rest of the world. Ultimately it will be able to connect up to 200,000 calls an hour using more than 20,000 international lines via cables and satellites.

A building contract has been placed by the Ministry of Public Building and Works with Holland & Hannen and Cubitts (Southern) Ltd. Construction is due to start in March and the building is due to be completed in 1972, when the installation of telephone equipment will begin.

Standing 150 ft high, it will occupy a 2½ acre site between Upper Thames Street and the River Thames, close to Cannon Street Railway Station. The site has already been cleared and excavated, and because it is close to the river a cut-off wall of sheet steel piling has been driven into the ground around the site perimeter.

One feature of the building design is that the six floors above ground level will be stepped and set back to preserve lighting angles and ensure that views of St. Paul's Cathedral from London Bridge are preserved. The building will incorporate a riverside promenade, public walkways at first floor level and a fire station fronting on to Upper Thames Street to meet the requirements of the Greater London Council and the City of London.

Each wall of Mondial House will feature full-length air conditioning ducts attractively clad in glass-fibre-reinforced polyester resin. These will form balconies at each floor level giving access for window cleaning and other maintenance work.

Equipment will be installed in stages with the exchange coming into operation in 1974 at about one-quarter of its eventual capacity. There will be a large degree of automatic testing and fault location built into the equipment. Diesel generators will provide the 8 million watts of electricity required to keep the exchange working in the event of a public electricity failure. To connect calls which customers cannot dial themselves, new design switchboards will be used with operators pressing buttons instead of plugging in cords.

By 1975 Mondial House will be connecting some 23 million calls a year, and this share of the total (about one-third) will steadily increase as additional equipment is installed to meet the expected increase in traffic. Mondial House, which ultimately will have a staff of about 2,000, will eventually be the main international telephone exchange in the United Kingdom.

Mondial House will be the third international automatic telephone exchange to be built in the United Kingdom. The other two are the existing main exchange in Faraday Building, Queen Victoria Street, and a new exchange now approaching completion in Wood Street. These three exchanges will be inter-linked and will work together as a total system. By 1975 over 60 per cent (currently over 70 per cent) of international telephone calls will still be starting or finishing in London (most of them in the City), and so international telephone exchanges must be located there.

Some 30 million international calls a year are now made from and to the United Kingdom and by 1975 this figure is expected to increase to about 70 million. UK has direct circuits to about 75 countries and other countries can be connected through intermediate points. At present about half the international calls made are dialled by customers and are connected through the existing exchange in Faraday Building. By the time the new Mondial House exchange is in service the proportion of dialled calls is expected to have risen to 70 per cent.

International calls that are not dialled by customers are connected by operators either in the Faraday or Wood Street buildings or at smaller manual exchanges in other parts of London. All these operators have access to the automatic equipment in Faraday Building and Wood Street.

### BOARD OF EDITORS

N. C. C. de JONG, B.Sc.(Eng.), C.Eng., M.I.C.E., F.I.Mech.E., F.I.E.E., Chairman  
 E. W. AYERS, B.Sc.(Eng.), C.Eng., F.I.E.E.  
 A. J. BARKER, C.Eng., F.I.E.E.  
 A. J. BARNARD, C.Eng., M.I.E.E.  
 G. E. BRETT, E.R.D., B.Sc.(Eng.), M.I.E.E.  
 A. C. CROSDALE, M.B.E., B.Sc.(Eng.), C.Eng., M.I.E.E.  
 J. MARTIN, B.Sc.(Eng.), C.Eng., M.I.E.E.  
 N. J. H. NINNIM, M.Sc., B.Eng., Managing Editor  
 R. A. SUDELL, Deputy Managing Editor  
 P. G. STEELE, M.Sc., B.Sc.(Eng.)  
 D. MILLINGTON, C.Eng., M.I.E.E. } Assistant Editors  
 T. R. K. RAITT }  
 B. FARR, A.B.I., Secretary-Treasurer  
 N. G. Crump, A.M.I.T.E., Advertisement Manager

### Copyright

The entire contents of this Journal are covered by general copyright, and special permission is necessary for reprinting long extracts, but editors are welcome to use not more than one-third of any article, provided that credit is given at the beginning or end, thus: "From *The Post Office Electrical Engineers' Journal*."

The Board of Editors is not responsible for the statements made or the opinions expressed in any of the articles in this Journal, unless such statement is made specifically by the Board.

### Subscriptions and Back Numbers

The Journal is published quarterly, in April, July, October and January, at 3s. per copy: 5s. per copy including post and packing (20s. per year) via inland mail, and 4s. 9d. (19s. or 2 dollars 50 cents Canada and U.S.A., per year) via overseas mail. Back numbers will be supplied, if available, price 3s. 6d. (5s. 6d. inland mail, 5s. 3d.

overseas mail) per copy. With the exception of January and October 1966 Journals, copies of the January 1967 and all earlier Journals are no longer available. Orders, by post only, to *The Post Office Electrical Engineers' Journal*, 2–12 Gresham Street, London, E.C.2.

Employees of the British Post Office can obtain the Journal through local agents.

### Binding

Readers can have their copies bound at a cost of £1 12s. 6d. plus 4s. 6d. return postage, by sending the complete set of parts, with a remittance to Press Binders Ltd., 4 Iliffe Yard, London, S.E.17.

### Remittances

Remittances should be made payable to "*The P.O.E.E. Journal*" and should be crossed "& Co."

### Advertisements

All correspondence relating to advertisement space reservations, copy, proofs, etc., should be addressed to the Advertisement Manager, *The Post Office Electrical Engineers' Journal*, 2–12 Gresham Street, London, E.C.2.

### Communications

With the exceptions indicated above, all communications should be addressed to the Managing Editor, *The Post Office Electrical Engineers' Journal*, 2–12 Gresham Street, London, E.C.2.

### Model Answer Books

Books of model answers to certain of the City and Guilds of London Institute examinations in telecommunications are published by the Board of Editors. Details of the books available are given at the end of the Supplement to the Journal.

*Some Important  
Pitman Titles*

## Introduction to Telephony and Telegraphy

E. H. JOLLY

75s (£3.75) net

## The Protective Gear Handbook

F. E. WELLMAN, H. G. BELL and  
J. W. HODGKISS

Second edition 80s (£4.00) net

## Solution of Problems in Electronics and Telecommunication

C. S. HENSON

Third edition 55s (£2.75) net  
Paperback 38s (£1.90) net

## Solution of Problems in Electrical Power

U. G. MALLIK

45s (£2.25) net

## Telex

R. W. BARTON

70s (£3.50) net

For copies of our catalogues giving full details of all our Electrical Engineering, Electronic Engineering and Telecommunication titles please write to the address below

## Pitman Publishing

39 Parker Street London WC2

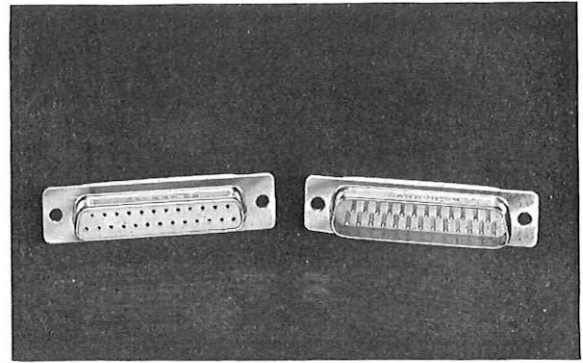

### P.O. APPROVED 'D' CONNECTORS

ITT Cannon offer the popular D\*M connector in 9, 15, 25, 37 and 50 ways fully approved to G.P.O. specification D2399 for Code 217 series connector. Also available are combination layouts using coaxial high voltage and heavy duty contacts.

**ITT Cannon Electric (G.B.) Ltd.,**  
Lister Road,  
Basingstoke, Hants.  
Tel: Basingstoke 3171.



## PO CORRESPONDENCE COURSES IN TELECOMMUNICATION ENGINEERING

For students of Telecommunication Engineering a series of PO complete correspondence courses is available. Each course consists of lessons, questions and model answers.

**SYLLABUS COVERED.** City and Guilds of London Institute—Telecommunication Technicians Course and Advanced Studies in Telecommunication and Electronics.

**SUBJECTS AVAILABLE.** Engineering Science, Telecommunication Practice, Practical Mathematics, Mathematics for Telecommunications, Telecommunication Principles, Line Plant Practice, Radio and Line Transmission, Communication Radio, Telephony and Telegraphy and the advanced subjects:—Digital Elements and Switching Principles and Advanced Telephony.

**PRICES.** £5 10s 0d per subject for non-tutored 1st to 4th year subjects and £10 15s 0d per subject for self-tutored Advanced Courses.

**ORDERS.** PO Engineers should order the courses through their staff group. All other orders can be sent to:—Mr M C Ringe, THQ/TP7.1.3 (Room 104), 90-91 Wood Street London EC2 (Telephone 01-432 3409).

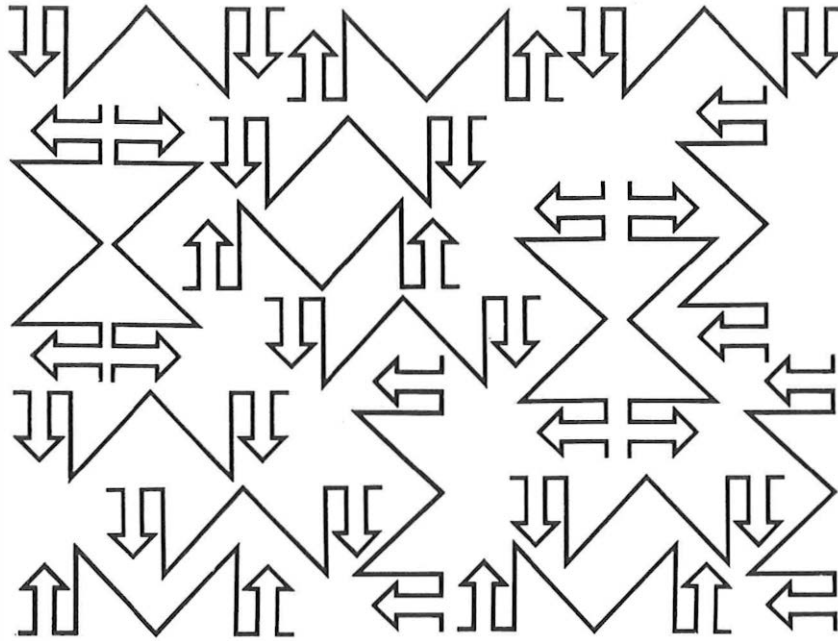





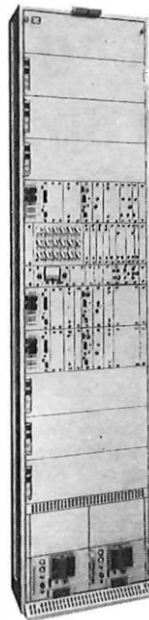

# 18 programme channels per rack

## CM-18A1 PROGRAMME MULTIPLEX

18 high-quality programme channels compatible with 60 telephone channels over the same bearer circuit. Any channel pair in a group of channels may be chosen for stereophonic programme transmission without need for pre-settings. Frequency shift eliminated by carrier regeneration at the receiving end. Non-oven oscillators are used.



Independent channels. Economic installation even with a small number of programme channels. Performance complying with CMTT\* recommendations in a 2500 km circuit with three cascaded audio modulations. No need for compandor. Automatic level control. Emphasis network complying with CCITT standards.  
\* Doc. CMTT/119 - September 17, 1968.

- |                                |   |   |   |
|--------------------------------|---|---|---|
| RADIO RELAY SYSTEMS            |  |  | DATA TRANSMISSION SYSTEMS               |
| MULTIPLEX TELEPHONE SYSTEMS    |  |  | TRAFFIC CONTROL SYSTEMS                 |
| TV AND FM BROADCASTING SYSTEMS |  |  | TELECOMMUNICATION EQUIPMENT AND SYSTEMS |

*Telettra*

## TRY THE NEW WAY

# ROLL-A-DRUM

SUPPORTS CABLE DRUMS,  
WITHOUT JACKS

Are you still using the clumsy, dangerous old method of hoisting cable drums on jacks? Today scores of up-to-date firms are using the Roll-a-Drum. They all report excellent results! The Roll-a-Drum operates swiftly on smooth-running rollers from ground level. Compared with the price of similar-capacity jacks it is a very economical proposition indeed, at £20. DELIVERED IN U.K. Write for leaflet, sent by return.

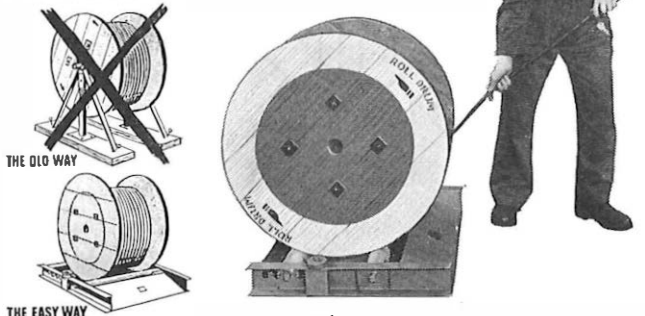

**ERSKINE** *Laboratories* LIMITED  
Scarborough  
Tel: 0723-2433

## VALUABLE FREE BOOK

Tells You How to Pass Your C. & G.  
Examination at First Attempt!

All Post Office personnel who are anxious to obtain early promotion should at once send for a copy of our handbook "ENGINEERING OPPORTUNITIES" which, among other intensely interesting matter, describes our unique methods of preparation for the CITY AND GUILDS EXAMINATIONS for the Telecommunication Technicians' Certificate and for individual subjects—Mathematics, Engineering Science, Engineering Drawing, Elementary Telecommunication Practice, Telecommunication Principles, Radio and Line Transmission, Telegraphy and Telephony, Line Plant Practice. It also contains details of our courses covering the G.C.E. subjects required for promotion to Assistant Engineer, Telecommunication Traffic Superintendent and other grades; and the City and Guilds examinations in Electrical Engineering Practice, the A.M.I.E.R.E. and A.M.S.E. Examinations, in addition to a wide range of non-examination courses in all branches of engineering—Radio and Electronics, Electrical, Mechanical, etc.

We also provide tuition for the Radio Amateurs' Examination and the P.M.G. Certificates for Radio Operators, with or without Morse training. Details are given in the handbook.

On "SATISFACTION OR  
REFUND OF FEE" terms

If you intend to make the most of today's opportunities, you cannot afford to miss reading "ENGINEERING OPPORTUNITIES." It tells you everything you want to know to secure advancement, and describes many opportunities you may now be missing through lack of information. Send for your copy today—FREE and without obligation.

BRITISH INSTITUTE  
OF ENGINEERING TECHNOLOGY  
727D ALDERMASTON COURT,  
ALDERMASTON, BERKSHIRE

# BIET

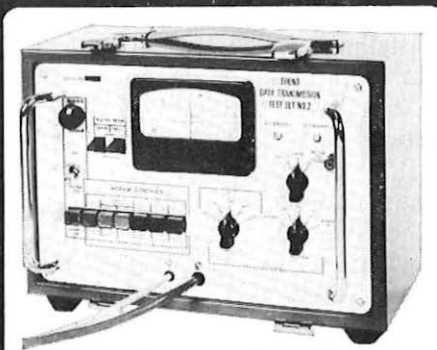

Trend Data Transmission Test Set No. 2



Trend Distortion Generator

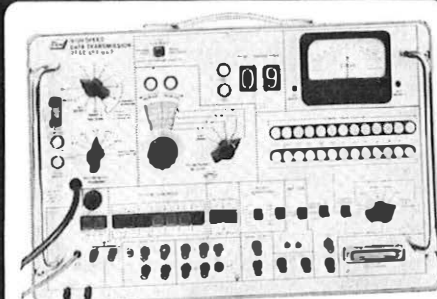

Trend High Speed Data Transmission Set No. 5

## Looking for High Speed Testing?

Then this range of Test Sets and equipment by Trend Electronics Ltd. provides the complete answer to ensuring that your Data Transmission Systems are always operating at the peak of their efficiency.

The Trend Test Sets Nos. 2 and 1-3 (whose usefulness is extended by the Distortion Generator No. 3), have been designed to complement each other in providing a range of equipment for testing most types of modems, transmission lines and data link equipment.

The new Trend Test Set No. 5 is intended for use with the new generation of high speed data transmission equipment, to avoid expensive and time-consuming errors and delays

The Trend Autocall unit is another aid to fast, efficient communications. The Autocall (aimed at our Export markets) performs automatically all the functions usually carried out by an operator in originating a data call over a public telephone network.

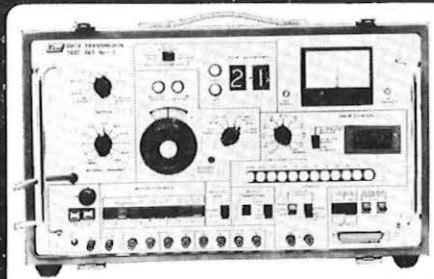

Trend Data Transmission Test Set No. 1-3



Trend Automatic Calling Equipment No. 1  
A G.P.O. design developed by Trend  
under contract to the G.P.O.

Talk to Trend for more details of how their full range of transmission test equipment can help you improve your data transmission installations.

# trend

Trend Electronics Limited

ST. JOHN'S SESTATE, TYLERS GREEN, HIGH WYCOMBE, BUCKS  
Telephone: 0494 2221

# STC Telecommunications

# Introducing Stick-a-Strip

## Self adhesive impact cable A new product from STC

In modern office planning Stick-A-Strip makes obsolete those ungainly telephone wires, the sort you see stapled around skirting boards.

Stick-A-Strip is a flat cable—4 conductors in a plastic cover with impact adhesive on one side. Stick-A-Strip lays flat against walls, skirting boards, or under carpets. No mess. Neat and smooth instead.

Stick-A-Strip cable isn't just for telephones, either. It can be used for a great variety of low voltage applications.

And Stick-A-Strip can be moved and repositioned. It'll still stick and look smart.

Stick-A-Strip can even make skirting boards beautiful.

Just how low can you get.

Deliveries available ex stock in 50 metre packs. In colours Grey or Cream.

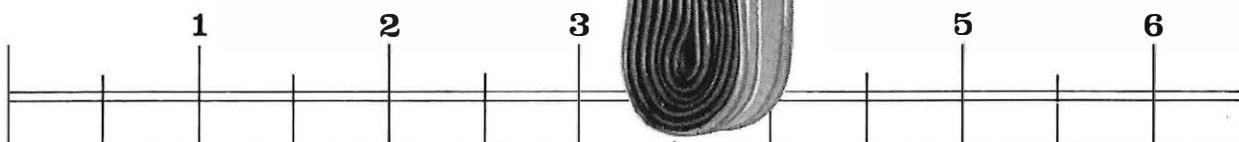

For further information—write, 'phone or telex.  
Standard Telephones and Cables Limited,  
Plastic Telephone Cable Division, Corporation Road,  
Newport, Monmouthshire, NPT OWS.  
Tel: 0633 72281. Telex: 49368.

an associate of  
**TTT**

Standard Telephones and Cables Limited

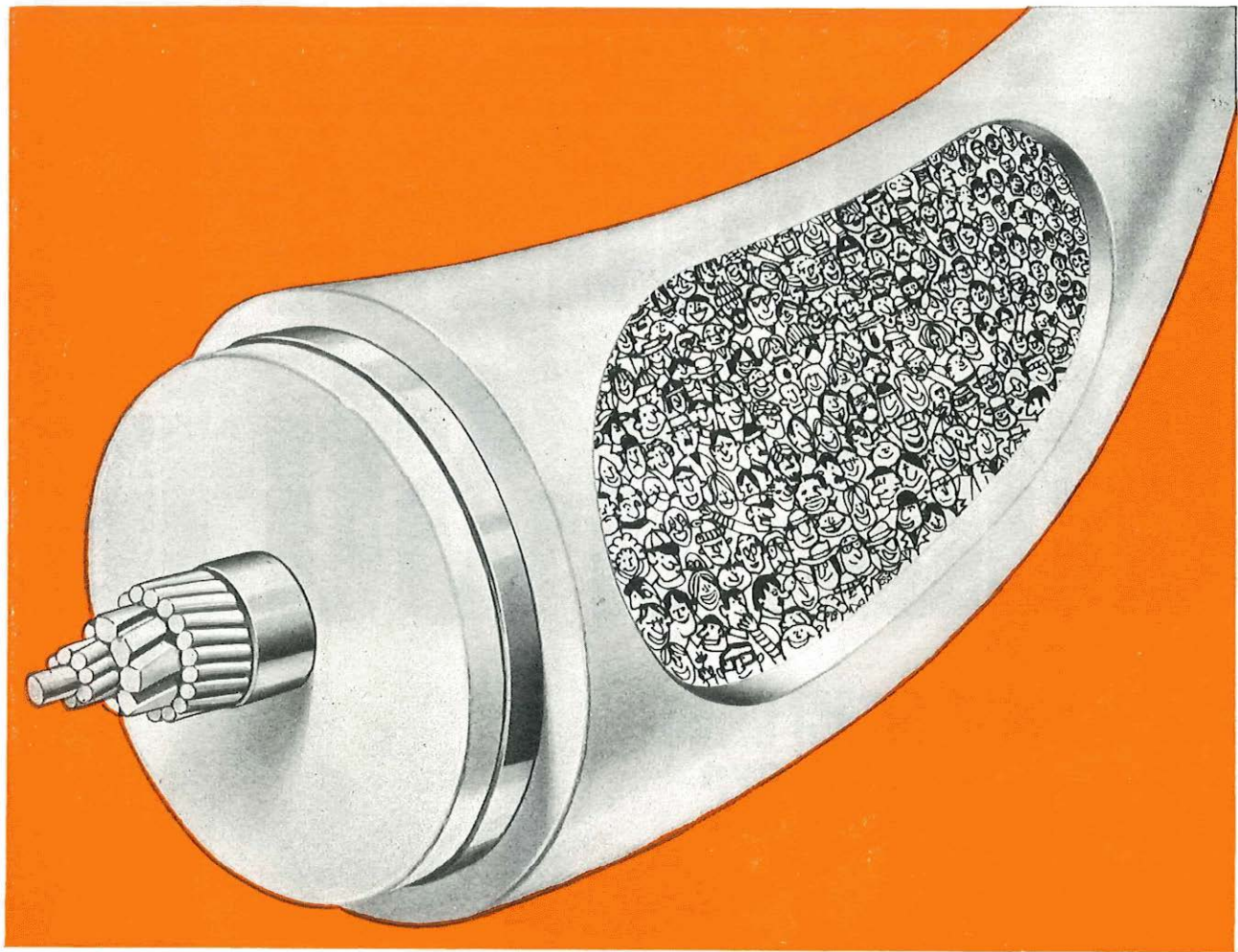

# Soon 1840 people will reach the Canaries by tube—simultaneously!

The tube is the new undersea cable system made by STC. With an overall diameter of 1.75 inches, it has the astonishing capacity of 1840 separate telephone circuits each of full 3 kHz capacity. The world's largest to date. STC's first system in the Canaries had only 160 channels. But now that they have Subscriber Trunk Dialling (STD) the Compañía Telefonica Nacional de España needs another cable.

And again STC has been asked to provide this. Naturally. Because 1840-channels is only one of a succession of STC firsts in this field. First with 160- and 360-circuit deep-water systems. First with the master/slave power feeding system. First with the equaliser test lead making cable laying that much easier. But submarine cables, repeaters, equalisers and terminal equipment

are not all that we offer. Add an overall capability for systems planning, project management, installation of complete systems, including civil engineering works and services—and you have a unique organisation able to meet any requirement, anywhere. Standard Telephones and Cables, Submarine Systems Marketing Division, North Woolwich, London, E.16, England.



## 47,704 are better than one

If you want a light, inexpensive headset, you can't do better than the British Post Office Corporation. For 47,704 of their girls, they chose STC sets. So should you.

Our sets are light as a feather, strong as a whip, and offer incredible value for money. They weigh a mere 4 ozs, and when your girls wear them, they won't notice a thing. The headset leaves their hands free to plug in lines or do their make-up, and however violently they shake or shrug, the headset stays put.

Better still, these sets are quite indestructible. Black or grey, take your pick.

So next time you're thinking of buying headsets, use your head. Buy STC.

Write, phone or telex for leaflet D/104 to:—  
Standard Telephones and Cables Limited,  
Subscriber Apparatus and Acoustic Division,  
New Southgate, London, N.11, England.  
Telephone: 01-368 1234. Telex 21917.

an associate of

**ITT**

Standard Telephones and Cables Limited



## Easy money

For every Deltaphone your subscribers hire, you get a few shillings/schillings/krona/dollars extra every year.

With a lot of subscribers, you naturally get a lot more shillings/schillings/krona/dollars etc. every year.

And your subscribers get a very beautiful instrument (this gem of a telephone comes in several fashionable colours, to blend with the decor). With a few rather nice things other telephones don't have, like a gentle warbling tone (the volume is adjustable) instead of a loud insistent ring.

And an optional luminescent dial that glows in the dark.

And the fact that it weighs only a few ounces. And that it's only 4.3 inches (105 mm) wide, means it can be held comfortably in the hand.

Best of all, with all this extra money rolling in, very little rolls out. Because the Deltaphone is of modular construction and needs only a screwdriver for any repair job.

So why not stock up with the STC Deltaphone?

It's so slim and elegant, your subscribers are sure to ask for it.

So write to: Standard Telephones and Cables Limited, Subscriber Apparatus and Acoustic Division, Oakleigh Road, New Southgate, London N.11, England. Telephone: 01-368 1234. Telex: 21917.

an associate of

**ITT**

Standard Telephones and Cables Limited

# STARPHONE by STC

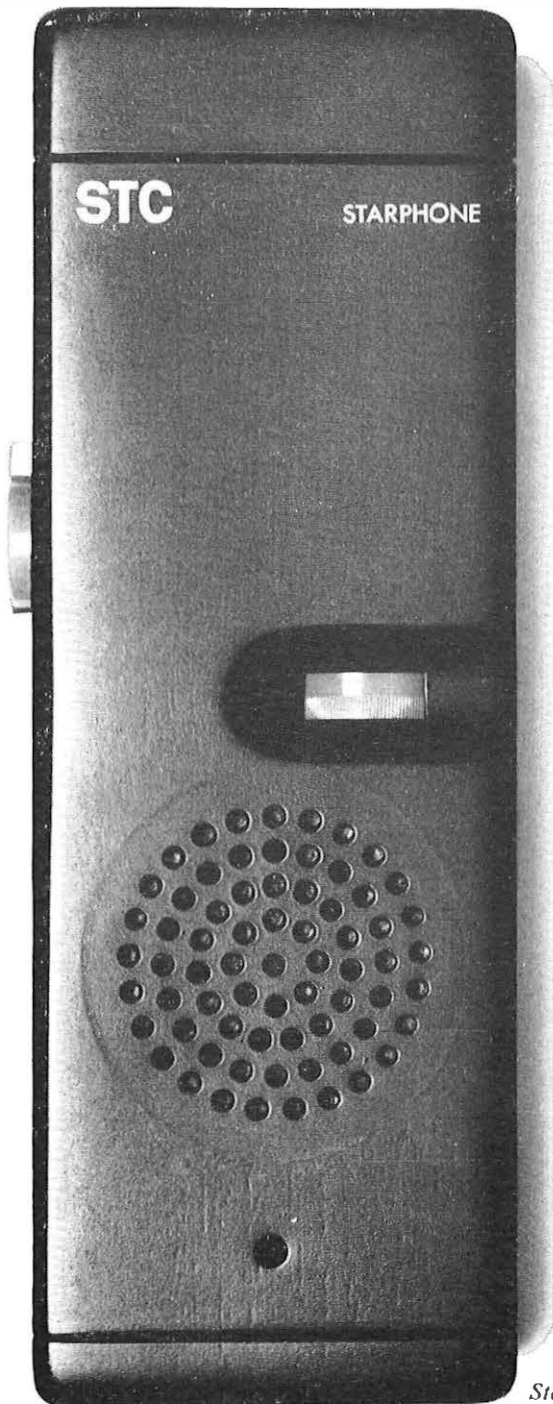

*Starphone—actual size*

## The World's Smallest UHF Radiotelephone

The Starphone is unique. It's the first radiotelephone designed to go in the pocket without external wires or rods. Operating on UHF, STC Starphone has an astonishing penetration of buildings and steel structures, and can give you instant two-way communication with your staff over a wide area.

Write for details to  
STC Mobile Radiotelephones Limited,  
New Southgate, London N.11. England.  
Telephone: 01-368 1200.  
Telex: 261912.



# Have know-how will travel

Plonk us down anywhere and we feel at home. So long as we've got a telecommunications problem to get stuck into. Simple or complex. For customers large or small. We put at your disposal all STC's equipment and that of our associates. The knowledge gained from decades of international experience. Plus the

global resources of ITT. We can help you establish or expand a communications network. Carrying speech, telegraphy, TV, data or telemetry. Using whichever form of transmission suits you best. You can just pick our brains or leave the whole job to us. Lease or buy the equipment involved. And we can either handle the

maintenance ourselves or train your own personnel.

Just tell us the problem – and leave it to us.

For details and our brochure 'Total Capability' please contact: STC Project and Field Services Division, Basildon, Essex. Telex: 99101 (STC Basildon).

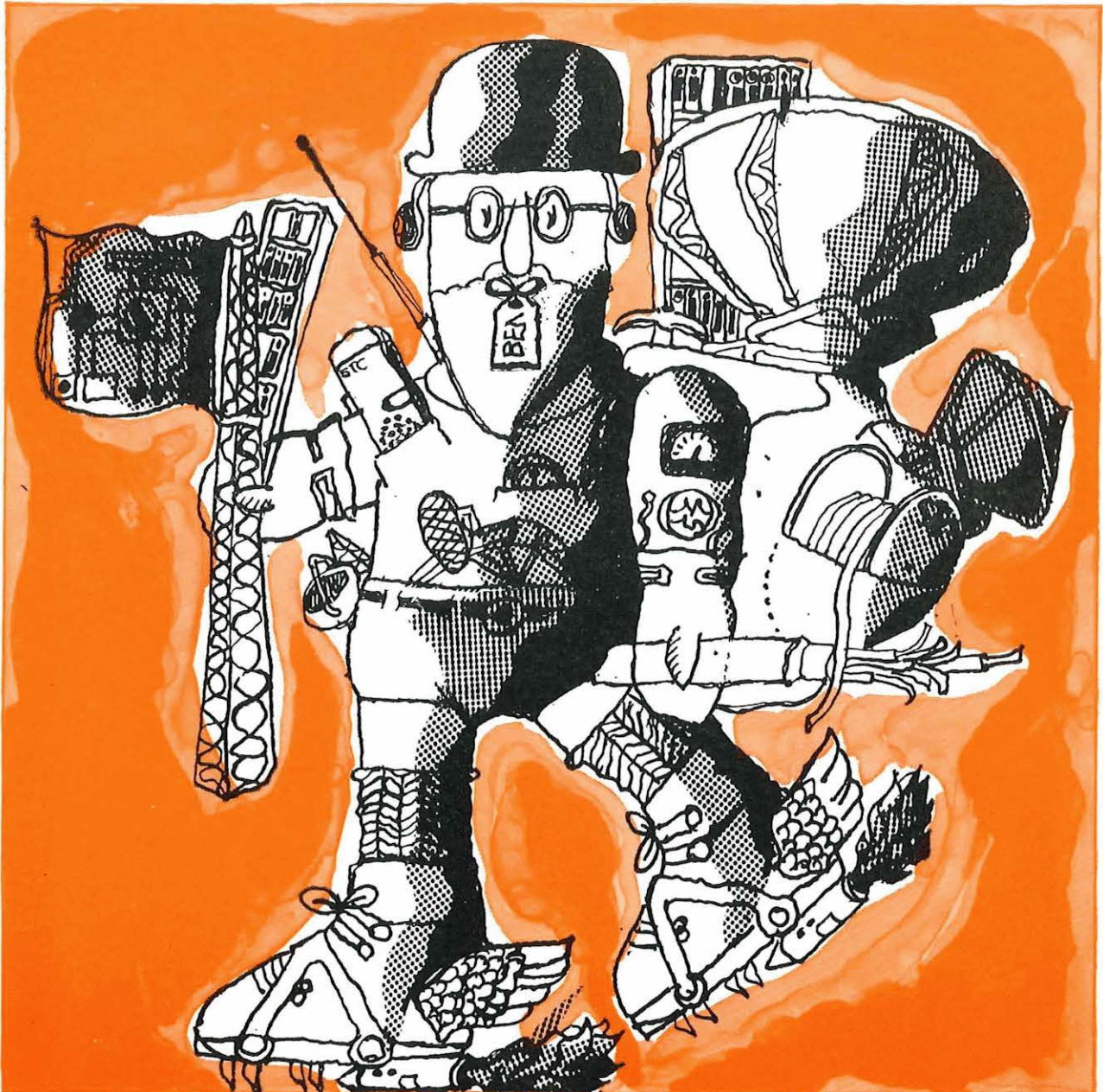

an associate of  
**ITT**

Standard Telephones and Cables Limited

## STC Telecommunications

### *Treble your underground capacity*

With STC's 12 MHz coaxial cable system type LG12A. This all solid-state system will provide up to 2700 telephone circuits on existing 9.5 mm (0.375 inches) diameter coaxial cables. The repeaters are buried in sealed housings below ground at 4.5 km (2.8 miles) intervals and are power fed over the cable.

The LG12A was the first all solid-state coaxial system of its type to be installed anywhere in Europe, and is currently in service, or on order, for U.K., Austria, Spain, South Africa and Australia.

And for you, advanced technology in the Queen's Award winning LG12A means reliability, economy, dependability and higher capacity.

For more information, write to:-  
Standard Telephones and Cables Limited  
Microwave and Line Division  
Basildon, Essex, England.  
Telex: 99101 (STC Basildon)

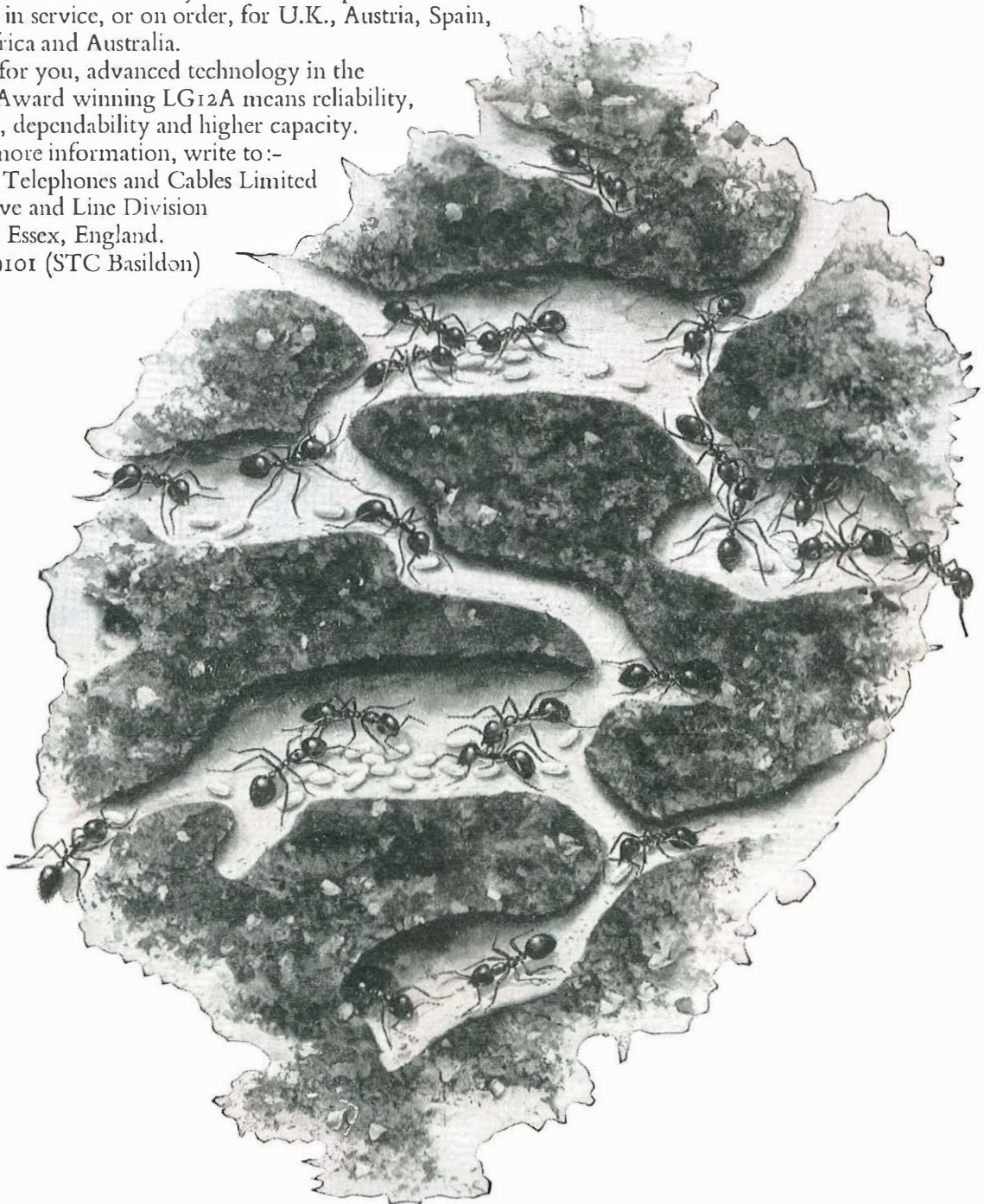

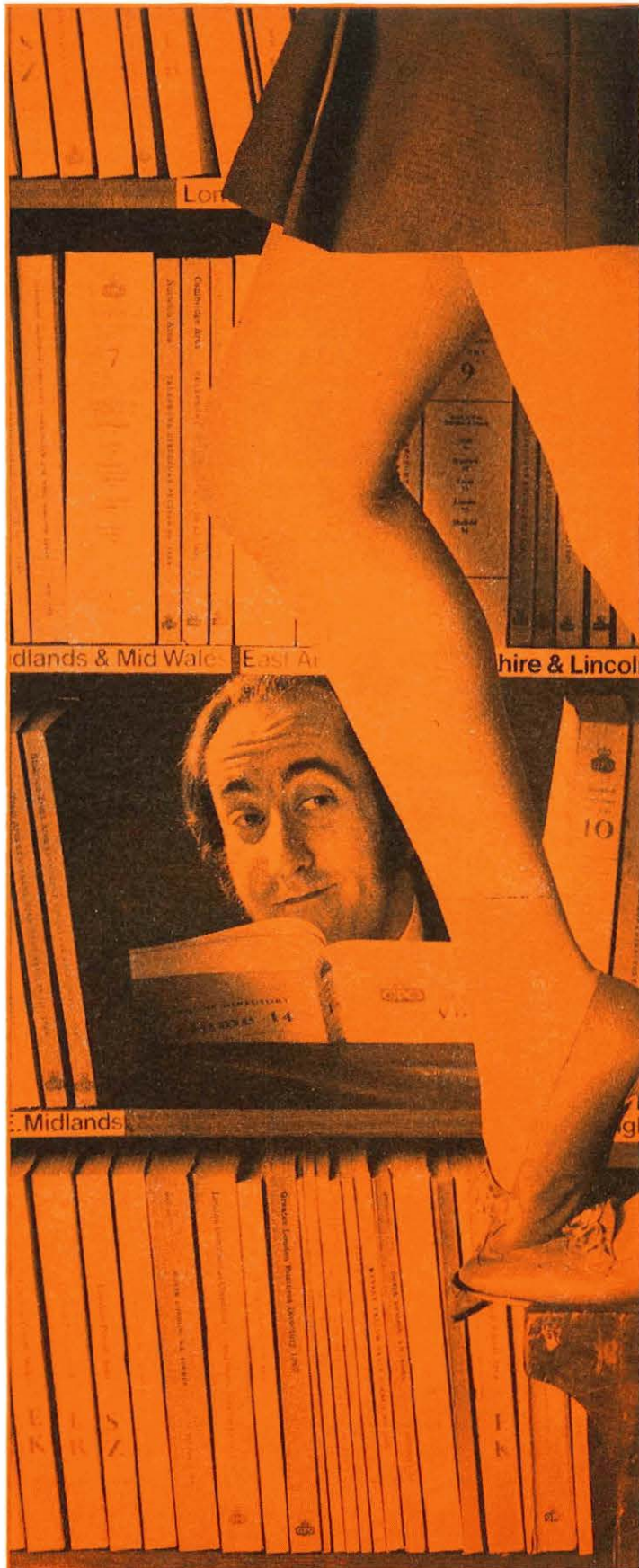

## Some of the books that have been written about us.

It's rather gratifying to see the results of our work in print. But not unusual for STC. A lot more volumes will adorn desks and kiosks around the country by the time we're through. At the moment, we're the only company involved in all 3 types of telephone exchange: Director, Non-Director, and Transit Switching. Transit Switching will eventually provide a new telephone network for the United Kingdom. In a year or so thirty Transit Switching centres all made and installed by us will be in operation for the Post Office Corporation.

Each will have its Group Switching Centres. Which in turn will be responsible for their own smaller, area exchanges.

The very fast signalling provided by Transit Switching will allow more calls through per minute. Fewer delays. Less time wasted, which will be greatly appreciated, because the telephone is the bread and butter of a lot of businesses.

Including ours.

Standard Telephones and Cables Limited, Telephone Switching Group, Oakleigh Road, New Southgate, London N.11, England.

Telephone 01-368 1234. Telex 21917.

an associate of  
**ITT**

worldwide telecommunications and electronics

**STC**

# The flattest sweeper news for years!

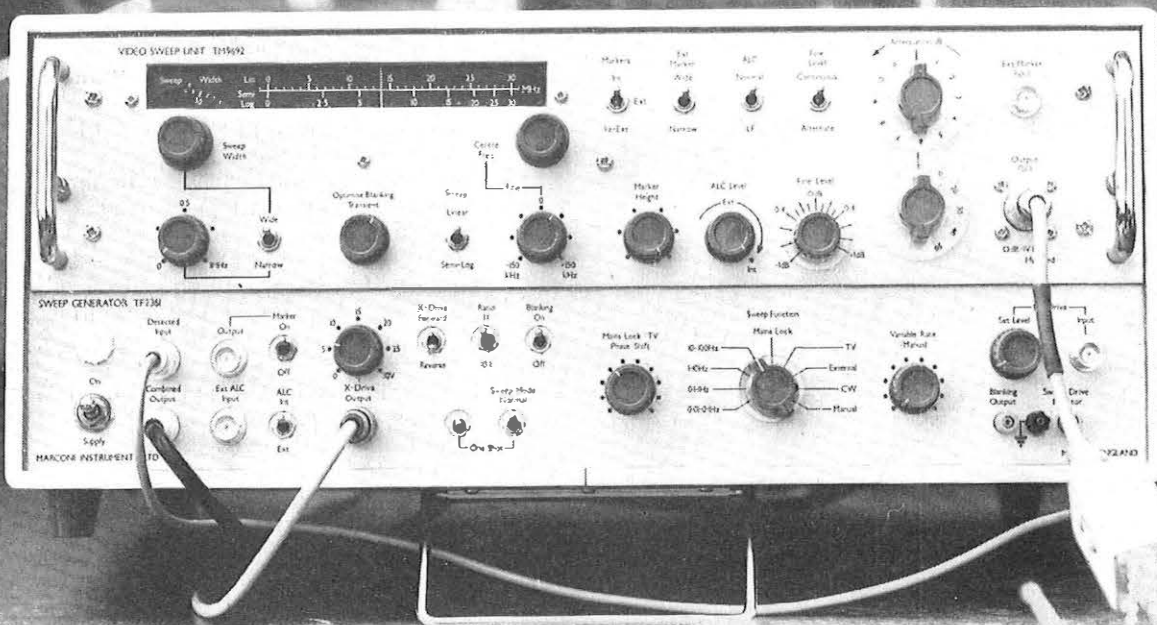

With a detected system flatness within  $\pm 0.05$  dB over the full video range, and a battery of features to aid precise measurement, the new TF 2361 provides a standard of accuracy not usually associated with general purpose sweep generators.

This powerful new instrument is designed for use with video or v.h.f. sweeper plug-ins to form accurate and comprehensive measurement systems – particularly in the TV field.

A wide range of sweep speeds from 0.01 Hz to 100 Hz make it ideal for use with X-Y plotters, display units or oscilloscopes.

The TF 2361 main unit, which contains common power supplies and circuitry for the plug-ins, features readily removable chassis units for straightforward servicing. Altogether an extremely comprehensive and well specified sweep generator.

**VIDEO** 25 kHz to 30 MHz \* Unique detected system flatness to within  $\pm 0.05$  dB over the full band makes it ideal for wide range, accurate frequency response checks on receivers, amplifiers, filters and attenuators.

\* Unique alternate-sweeps-at-different-levels feature complements the advantages of the flat output in making accurate frequency response checks.

\* Unique TV lock facility locks sweep to a TV sync and blanking waveform to provide a TV video sweep system. Price £960 f.o.b.U.K.

**V.H.F.** 1 MHz to 300 MHz \* Comprehensive internal and external markers can be added to the detected output or can be used separately: positive or negative pulse or birdie markers can be selected.

\* R.F. attenuator may be used separately.

\* Comprehensive range of detectors and probes available. Price £1128 f.o.b.U.K.



## MARCONI INSTRUMENTS LIMITED

A GEC - Marconi Electronics Company

Longacres, St. Albans, Herts. England Tel. St. Albans 59292. Telex 23350

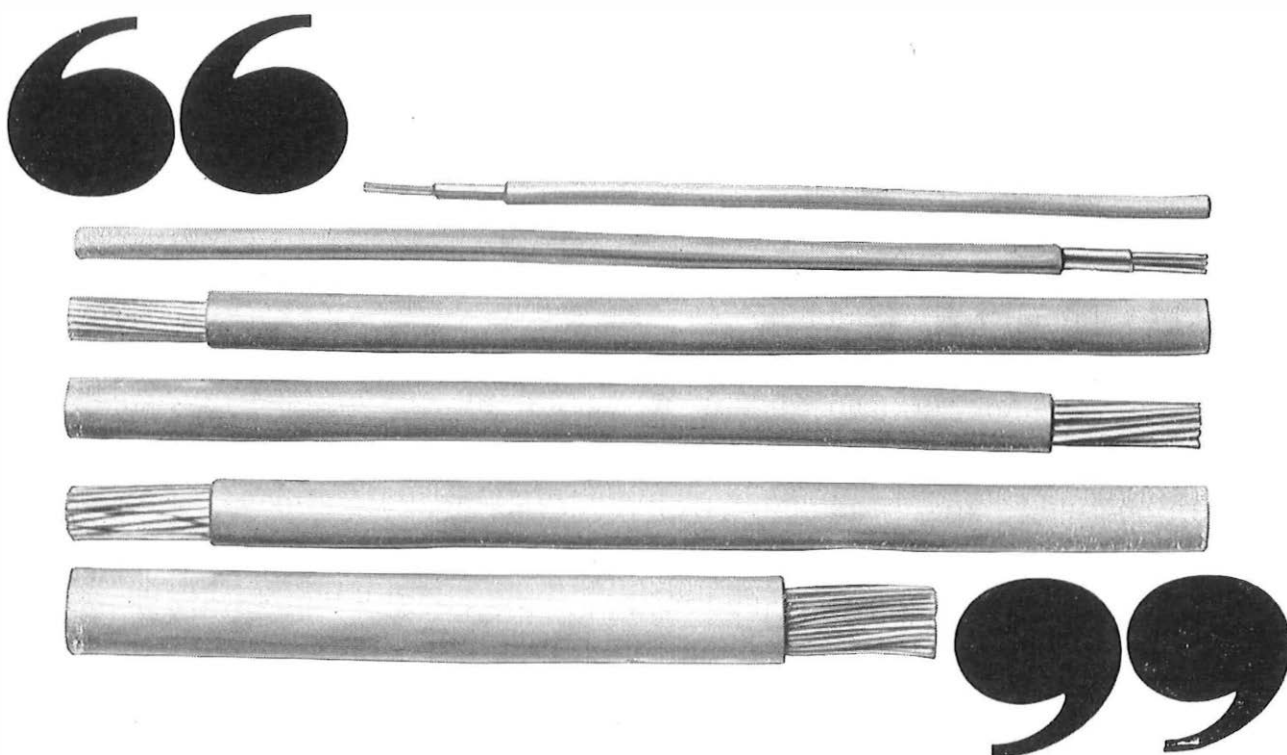

**“PIRELLI  
GENERAL”**  
**and the power  
of speech**

Internal telephone communication systems call for the same degree of reliability as for national networks. Pirelli General manufactures a range of multipair and multi-way internal telephone cables which are stocked for immediate delivery.

To reduce cross-talk in the multipair construction the pairs are twisted and laid-up with varying lays. Each cable has a distinct colour identification scheme for the cores or pairs which facilitates quick termination, and a Terylene ripper cord assists in quick removal of the PVC sheath. For further details ask for Publication C3:1968.

PIRELLI GENERAL CABLE WORKS LIMITED · SOUTHAMPTON · TELEPHONE: SOUTHAMPTON 20381



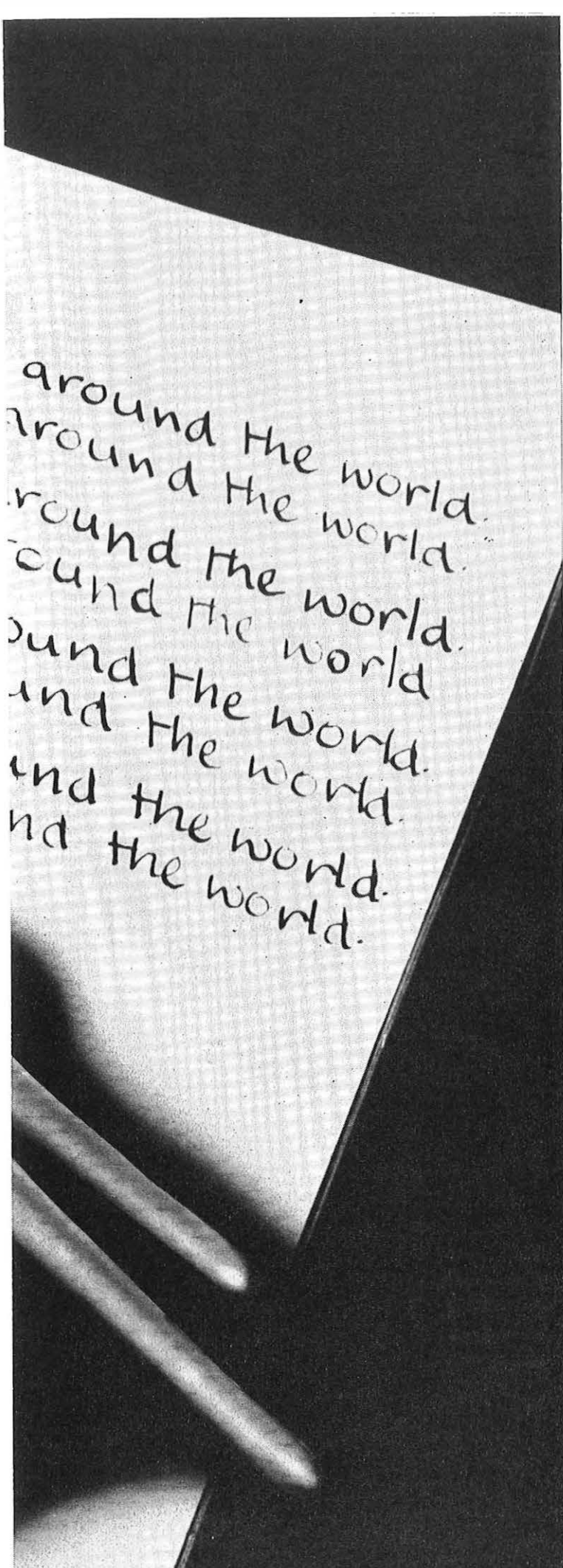

Take 4000 lines, and up. This is the scale of telephone exchange capacity which is now best handled by 5005 Crossbar.

Crossbar?

Crossbar is the internationally used name for a type of telephone switching rapidly replacing the older 'Strowger' electro-mechanical system that has been at work for over 50 years.

5005?

Plessey telecommunications engineers were first in the UK to see the need for this kind of equipment, 20 years ago, and developed 5005 Crossbar in anticipation of an exploding demand.

Crossbar is now a basic system in the current Post Office expansion programme.

As you might expect crossbar is more versatile, needs less maintenance than the equipment it replaces and it is compatible with electronic systems. It is also compatible with international switching systems and Plessey has installed several major crossbar switching centres at key points throughout the world.

The early Plessey lead in British crossbar is complemented by the first production electronic exchange in Europe (by Plessey) and, for that matter, by the first UK automatic Strowger exchange, at Epsom in 1912 (by Plessey). UK telephone history involves only these three systems. To claim a first in each is no accident. It reflects a planned process of research, development and production to meet predicted needs, a pattern which Plessey is rather good at.

This is why Plessey is a major international force in telecommunications.

Please write for further information on the Plessey 5005 Crossbar system.

The Plessey Company Limited,  
Telecommunications Group, Edge Lane,  
Liverpool L7 9NW, England.  
Telephone: 051-228 4830 Telex: 62267

 **PI PLESSEY**

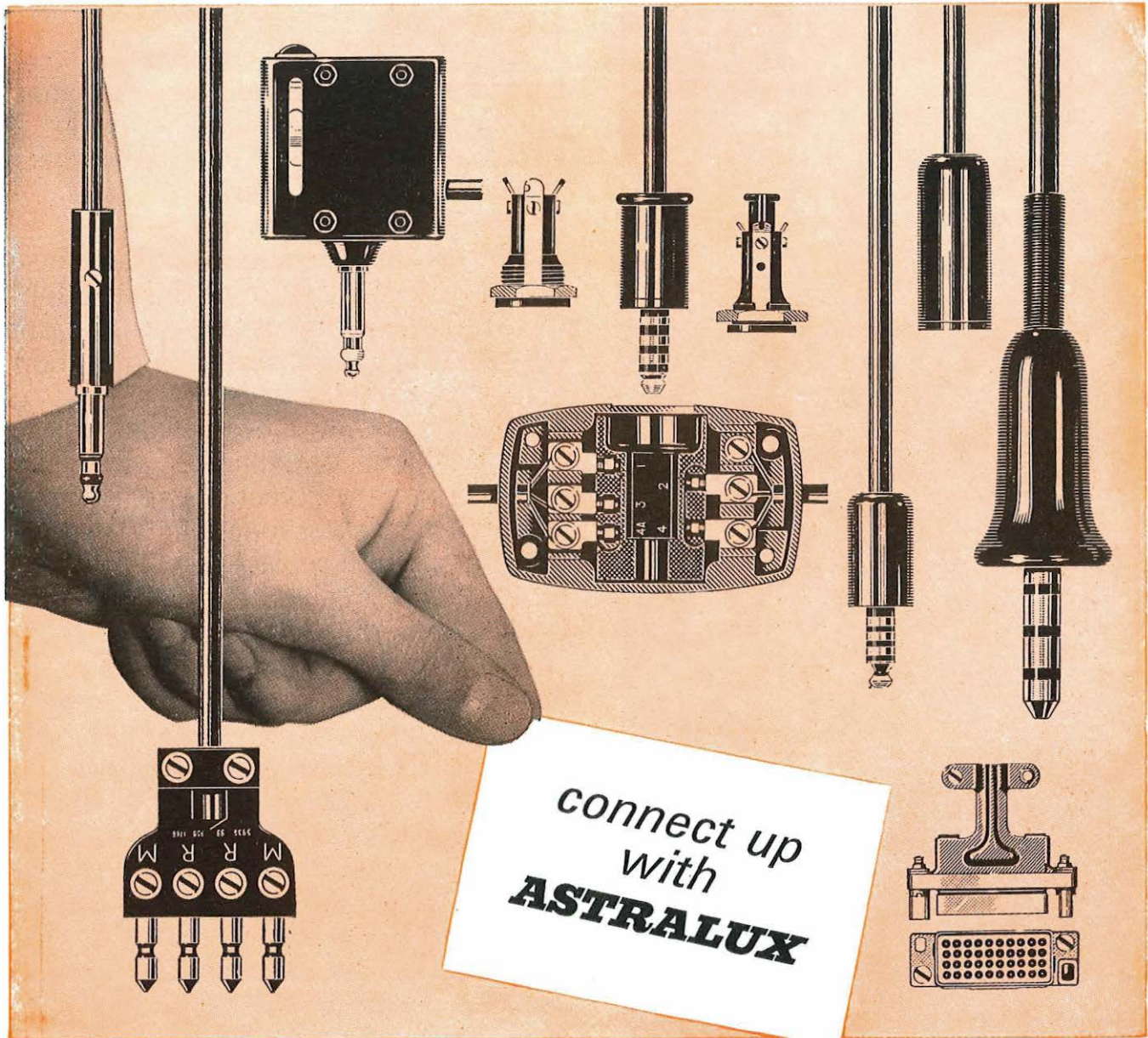

PLUGS, SOCKETS, JACKS—in all sizes and for every purpose—are made by the Special Products Division of Astralux Dynamics Ltd. They're chosen by the British Government and approved by the Post Office and Aircraft Industry. The special Astralux design service for prototype models is used by these organisations and by private industry. You can rely on Astralux efficiency and technical accuracy to produce equipment strictly to specification—and quickly. Plugs, Sockets and Jacks are just some of the products of a company streamlined to serve world-wide industry today. Learn more about what Astralux can offer *you*. Write to us for descriptive literature.

**Illustrated from left to right**

- |                                   |                     |
|-----------------------------------|---------------------|
| <b>1</b> Plug 316                 | <b>2</b> Plug 406   |
| <b>3</b> Plug 235                 | <b>4</b> Jack 84A   |
| <b>5</b> Plug 420                 | <b>6</b> Jack 95A   |
| <b>7</b> Socket 626 with Hex. Nut |                     |
| <b>8</b> Plug 671                 | <b>9</b> Socket 626 |
| <b>10</b> Plug Electrical 119     |                     |
| <b>11</b> 40-way Connector        |                     |
|                                   | male and female     |

**ASTRALUX** *dynamics limited*



# SWITCH WITH-

# ASTRALUX



# REEDAC\*

**Standard Reedac\*** The Standard REEDAC is a semi-solid state heavy-duty 50-60 cycle A.C. switch, which combines all the advantages of reed relay switches with solid state dependability. Thus REEDAC has a turn-on speed of 1 millisecond, combined with a 500 million operations life expectancy. The design of the REEDAC provides a sturdy compact package, sealed against environmental conditions—and completely silent in operation. This rugged design is ideally suited to withstand severe shock and vibration.

#### SPECIFICATIONS

**RATING:** 2, 4, 5, 7, 10 and 15 amps at 250V RMS inductive or resistive.

**APPLIED VOLTAGE:** 28 volts to 250V RMS 50-60 HZ.  
**INPUT:** 6, 12, 18, 24, or 48 VDC. (250mW).

**TEMPERATURE:** Operating: — 0°C. to + 70°C (with adequate heat sinking). Storage:— minus 40°C to + 100°C.

**OPERATE DATA:** Turn-on can occur anywhere in the A.C. cycle, but does not follow the bounce of the reed switch.

Turn-off occurs at approximately the zero current crossing point.

Standard REEDAC incorporate a thyrector to prevent false turn-on where line transients exceed the forward blocking voltage. In addition a R-C network is included to minimize the commutating  $dv/dt$  to one volt per microsecond.

**HOUSING:** Glass filled nylon case 1.8" x 1.5" x 1.0". Mounting is by means of two 0.187" dia. holes on 2.25" centres.

#### TERMINAL OPTIONS:

- (a) Solder lug type.
- (b) Quick-connect type.
- (c) 6-32 Lock Screw type.

**Synchro Reedac\*** THE CLASS II AND III SYNCHRO REEDAC are purely solid state or semi-solid state devices—depending on input requirements. The switching element consists of a Bilateral Thyristor (Triac), gate controlled by a solid state zero volt sensing circuit. Closing the external switch or by applying D.C. to the input terminals completes the circuit to the gate, where it will conduct into integral numbers of whole cycles. It will turn on no later than 4.0 volts in the angle. Turn-on occurs in integral numbers of whole cycles not to exceed 4.0 volts. Turn-off occurs at approximately the zero current crossing point. Class II 50-60 HZ, Class III 400 HZ.

Please write or telephone for our Reedac\* leaflet today.

\*Copyright

# ASTRALUX dynamics limited

Relay Division · Brightlingsea · Colchester · Essex · England · Telephone: Brightlingsea 2517/8

A slice from the exclusive Zener range by IR—  
**The Current Slicers.** What IR don't know about zener diodes  
 isn't worth knowing. Which is hardly surprising, since IR  
 are the world's largest independent manufacturers  
 of power semiconductors. The world's largest. And often the  
 cleverest, too. IR offer you the reliable, high-performance,  
 state-of-the-art zeners (still the only ones you  
 can get with lifetime guarantees) you need, deliver  
 them fast anywhere in the world, and back  
 them up with comprehensive technical, test  
 and applications data. If you'd like a slice  
 (or a million), contact IR or your  
 IR Distributor.

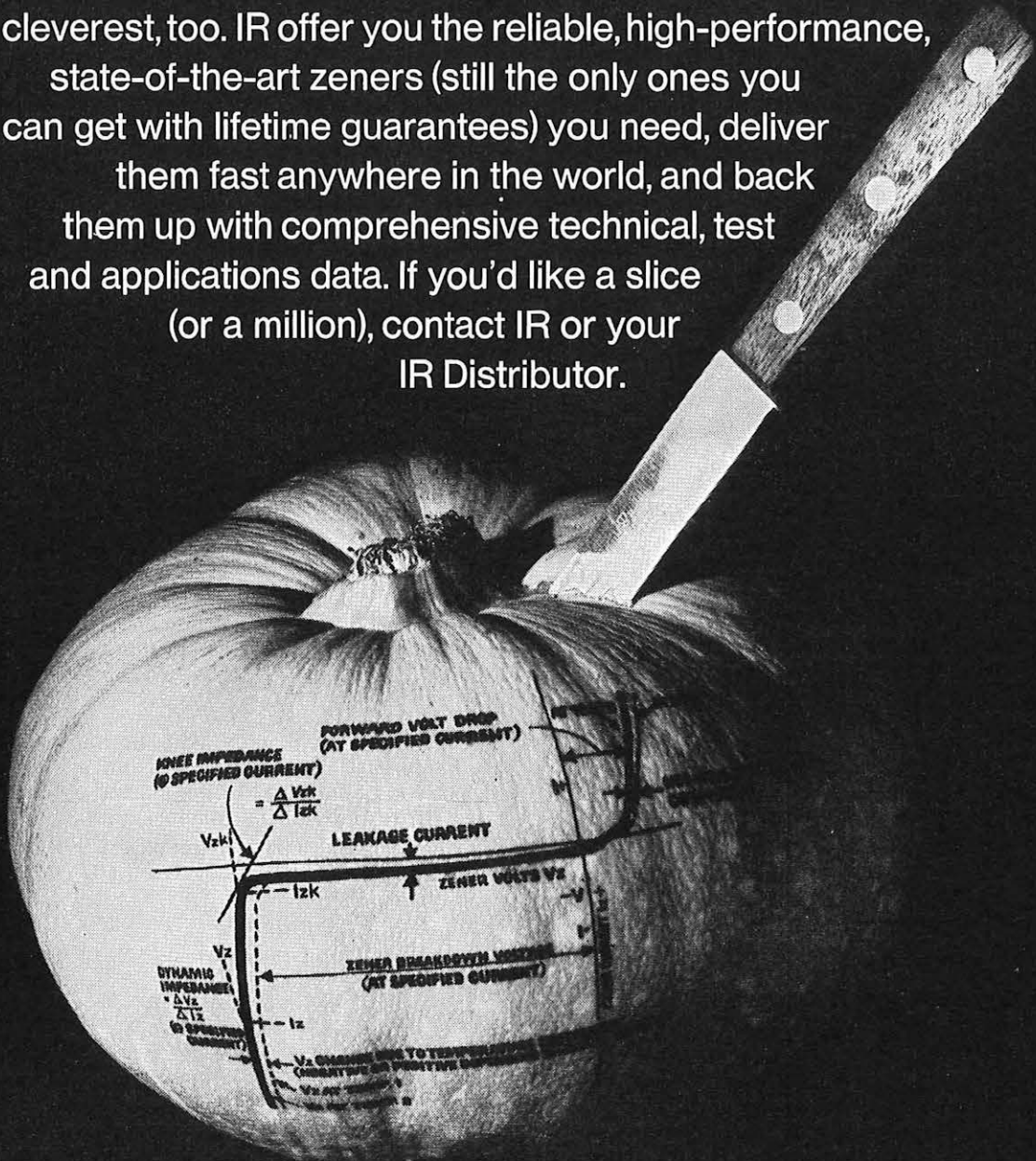

**the current slicers**

International Rectifier · Oxted · Surrey

**the GPO  
are proud to serve  
55 million people**

**WHITELEY  
are proud to serve  
the GPO**

The development and manufacture of telecommunications equipment requires forethought, research, technical expertise and a great deal of co-operation. Whiteley of Mansfield have been providing these services to the G.P.O. and industry for many years, producing anything from a control knob to complete electronic and telecommunications equipment.



**Point to Point  
Broadcasting  
Radio Relay  
Ground to Air  
Navigational Aids  
Business Radio**

**Design**

Site layouts  
Aerial System Design

**Aerials**

LF 'T' and 'L' Aerials,  
Mast Radiators,  
HF Dipoles, Quadrants,  
Rhombics, Log Periodics,  
Vertical Incidence Arrays,  
Conicals, Biconicals  
VHF & UHF Yagis, Helices,  
Ground Planes, Colinears,  
Whips, Marine Aerials,  
Television Arrays to 100kW e.r.p  
**MICROWAVE** Passive Reflectors,  
Dishes 3" to 60 ft. dia.

**Supporting Structures**

Self-supporting Towers,  
Tubular and Lattice Masts,  
Telescopic Masts

**Accessories**

Coaxial and open wire Feeders,  
Filters, Aerial Switches,  
Lead-in panels, Earth Systems,  
Air-cooled Transmitter Loads,  
Termination Networks

**Installation**

World Wide Service

# C&S Antennas

**provide  
a complete  
aerial service  
LF to Microwave**

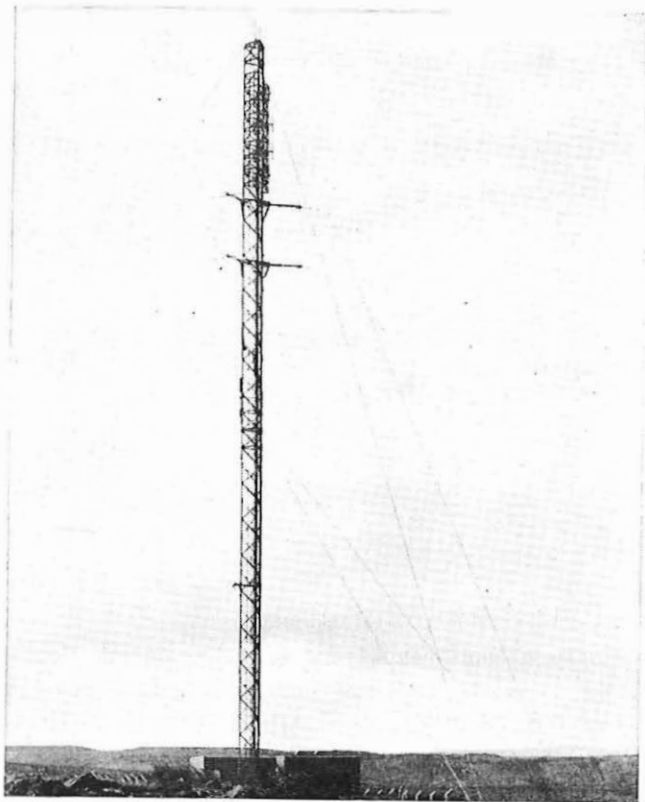

VHF Mast and Antenna System for the ITA-BBC Television Relay Station at Abergavenny. Photograph—South Wales Argus.



# C&S Antennas Ltd

Wentworth House, Eastern Avenue, Ilford, Essex, England.  
Telephone: 01-554-0102 Telex: 25850 Cables: Antennas Ilford (England)

# Every day is a farad day with us!

Why? Because every day we can meet your every need for capacitors. We can supply everything from a 10pF tubular ceramic to a 15,000  $\mu$ F electrolytic, from stock.

It's the same with all our capacitors (we've shown some of them below). And all the other components we can supply—everything from Adhesives to Zener diodes. Order today and they'll be in the post today.

So what do you want by tomorrow at the latest?

## **Radiospares**

P.O. Box 427,  
13-17 Epworth Street, London EC2.  
Tel: 01-253 9561. Telex: 262341.



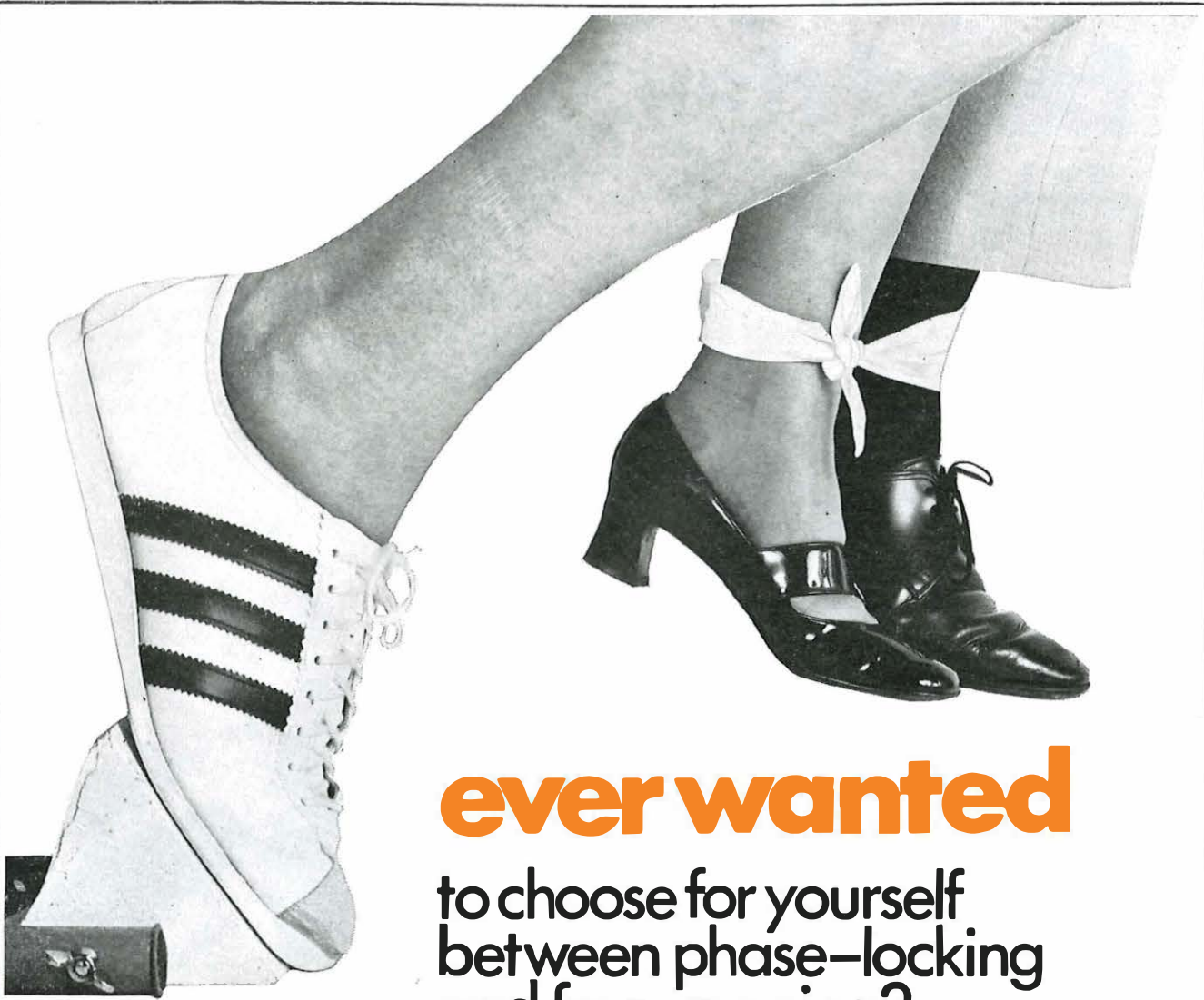

**ever wanted**

to choose for yourself  
between phase-locking  
and free-running?

**with GEC  
Multiplex, you can!**

**4 M-CG CARRIER  
GENERATING EQUIPMENT**

When it comes to carrier supply frequencies, GEC Multiplex equipment gives *you* the choice. They can be phase-locked to the frequency of the incoming pilot, or derived from crystal controlled master oscillators of particularly high stability to permit free-running. This is just one of the facilities provided with GEC 4M-CG Carrier Generating Equipment. Others include **Provision for Major/Minor stations.** **Full or partial duplication with automatic changeover.** **To CCITT or North American requirements.**

**G.E.C.**

**Takes telecommunications into tomorrow**

GEC-AEI TELECOMMUNICATIONS LTD. OF COVENTRY, ENGLAND.

A Management Company of The General Electric Co. Ltd. of England.

# ever wanted

to improve your  
capacity for  
conversation?

# with the GEC small-diameter co-axial cable system 4K9B you can!

- \* 960 telephone circuits.
- \* 4.4 mm. (0.174 in.) or 9.5 mm. (0.375 in.) coaxial-cables.
- \* Power-fed repeaters at a maximum spacing of 4010 m. (4,400 yd.) for 4.4 mm. cable and 9250 m. (10120 yd.) for 9.5 mm. cable.
- \* Performance to CCITT recommendations.
- \* Proven in operation with over 230 systems covering 6000 route miles being supplied in the U.K. alone.
- \* Underground repeater boxes to house up to six systems.



**S.E.C.**

**Takes telecommunications into tomorrow**

GEC-AEI TELECOMMUNICATIONS LTD, OF COVENTRY, ENGLAND.

A Management Company of The General Electric Co. Ltd. of England.



**ever  
wanted** to cope with up to eight  
at a time in each direction?



**with the GEC  
upper 6  
microwave system  
you can!**

For high density routes, the GEC 6.8GHz semiconductored microwave radio equipment can accommodate up to eight radio bearers in each direction of transmission, using a single antenna. The highly economical frequency usage provides up to 16 x 960 high-quality speech channels in the same frequency spectrum

**GEC MICROWAVE TYPE 68R9A**

**S.E.C.**

**Takes telecommunications into tomorrow**

GEC-AEI TELECOMMUNICATIONS LTD, OF COVENTRY, ENGLAND.

A Management Company of The General Electric Co. Ltd. of England.

IB/50



**“put me through  
to the manager...  
room service...  
theatre bookings...”**

Our new low line Cord Switchboard is at home wherever personal service is still important....

Even in the pace of today's modern world, personal service is expected and often necessary. The GEC low line Cord-type telephone switchboard combines elegance with efficiency and boasts adaptability to suit its surroundings, wherever they may be... whether in luxury hotels, hospitals, or even cruise liners. It's the ideal PABX private telephone system for situations where personal service counts.



Registered Design  
No. 940229



**Takes telecommunications into tomorrow**

GEC-AEI TELECOMMUNICATIONS LTD, OF COVENTRY, ENGLAND.

A Management Company of The General Electric Co. Ltd. of England.

18/48

## INDEX TO ADVERTISERS

	PAGE		PAGE
AIM Electronics Ltd. . . . .	26	Marconi Instruments Ltd. . . . .	11
Astralux Dynamics, Ltd. . . . .	15-16	Pirelli General Cable Works, Ltd. . . . .	12
British Institute of Engineering Technology . . . . .	3	Pitman, Sir Isaac, & Sons Ltd. . . . .	1
Cannon Electric (GB) Ltd. . . . .	1	Plessey Co., Ltd., The . . . . .	13-14
Cray Electronics Ltd. . . . .	27	Post Office . . . . .	1
C & S Antennas Ltd. . . . .	19	Radiospares . . . . .	20
Egerton Connectors Ltd. . . . .	25	Standard Telephones & Cables, Ltd. . . . .	4-10
Erskine Laboratories Ltd. . . . .	3	Telettra S.p.A. . . . .	2
GEC-AEI Telecommunications, Ltd. . . . .	21-24	Trend Electronics Ltd. . . . .	3
International Rectifier Co. (GB) Ltd. . . . .	17	Whiteley Electrical Radio Co., Ltd. . . . .	18

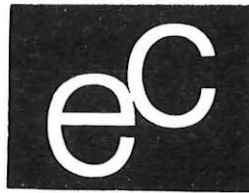

## A NEW JOINTING METHOD FOR TELECOMMUNICATION CABLES

**USED ON A WORLD WIDE SCALE**

**Producing high integrity joints on Copper and Aluminium Conductors**

**EGERTON 'B'-WIRE CONNECTORS**

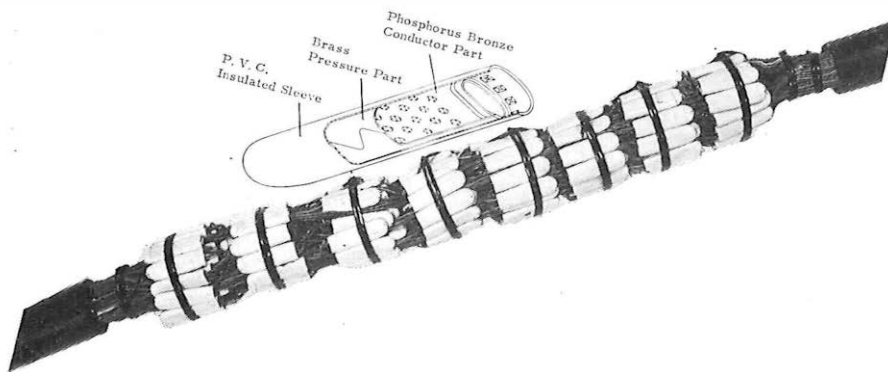

1. No stripping of the conductor insulation.
2. No deformation or twisting of the conductors.
3. No tip soldering of the joint.
4. No jointing skill required.
5. No complicated ancillary equipment needed.
6. No increase in diameter over the usual paper insulated conductor joint.
7. No increase in costs compared with crank handle, twisting and soldered joints.
8. Equally suitable for copper and aluminium conductors.

We also offer the following—Submarine Cable Jointing Equipment

Coaxial Jointing Tools

Cable Pulling Eyes and Swivels

B.I.C.C. Sheath Closure Equipment

Polyester Moulded Splice Cases for up to 200 pair cables

## EGERTON CONNECTORS LIMITED, LIDDON ROAD, BROMLEY, KENT

# 'What noise annoys a Post Office engineer?'

Whatever it is, there are many ways AIM can help recover signals from noise

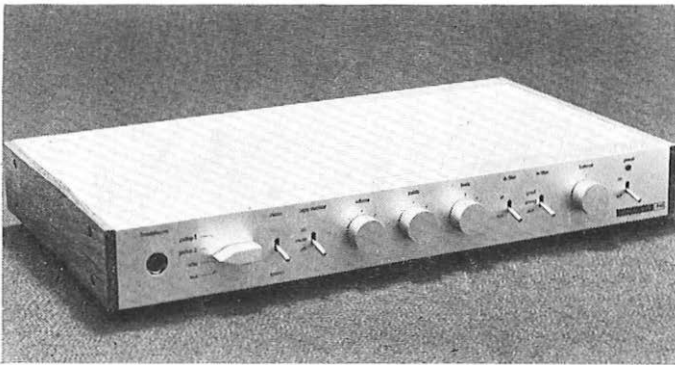

## THE MUSICAL WAY

Even a Post Office man must relax. The Cambridge Audio P40 Hi Fi Amplifier will cradle him in noiseless distortion-free arms. Full test certificate with each amp. Typical distortion at full output is 0.03%. Less than 0.01% below full output. Input stage can cope with 120dB dynamic range.



## THE COMPUTER WAY

AIM's new Correlation Function Computer sets the powerful new signal processing standard for the 1970's. This instrument can extract complex signals from up to 60dB of noise, compute impulse responses, measure flow rate, check room acoustics etc.

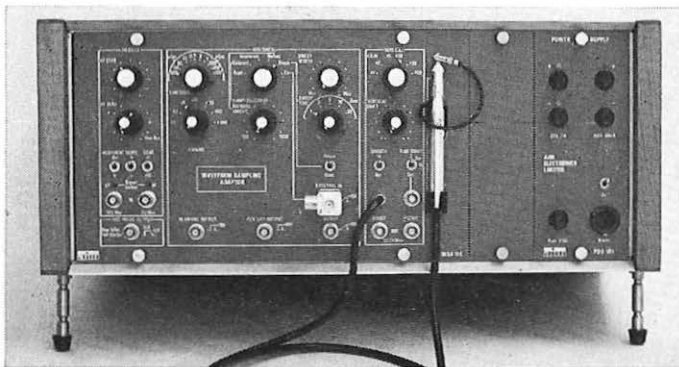

## THE SAMPLING WAY

The sampling lab in a box. The AIM sampler enables you to use low frequency scope or X-Y recorder to over 1GHz. Features a 100kohm probe, incoherent sampling, signal averaging. This instrument can improve signal to noise ratio by over 40dB within its frequency range.



## THE LOCK-IN WAY

With or without a reference signal, the AIM range of lock-in amplifiers can recover signals buried in up to 60dB of noise. Easily the most versatile system you can buy.

## ANY OTHER WAY

Cambridge Consultants Ltd offers contract research and development in electronics, physics and mechanical engineering. If none of our catalogue instruments solves your problem then we can design one for you.

We also manufacture: Fast A to D Converters, Tape Punch Drives, Pulse Generators, Wideband Power Amplifier, Log Amps, Filters, Infrared Components, Infrared Micrometers, Tracking Filters.

The River Mill  
St. Just, Huntingdon

R. A. ROE

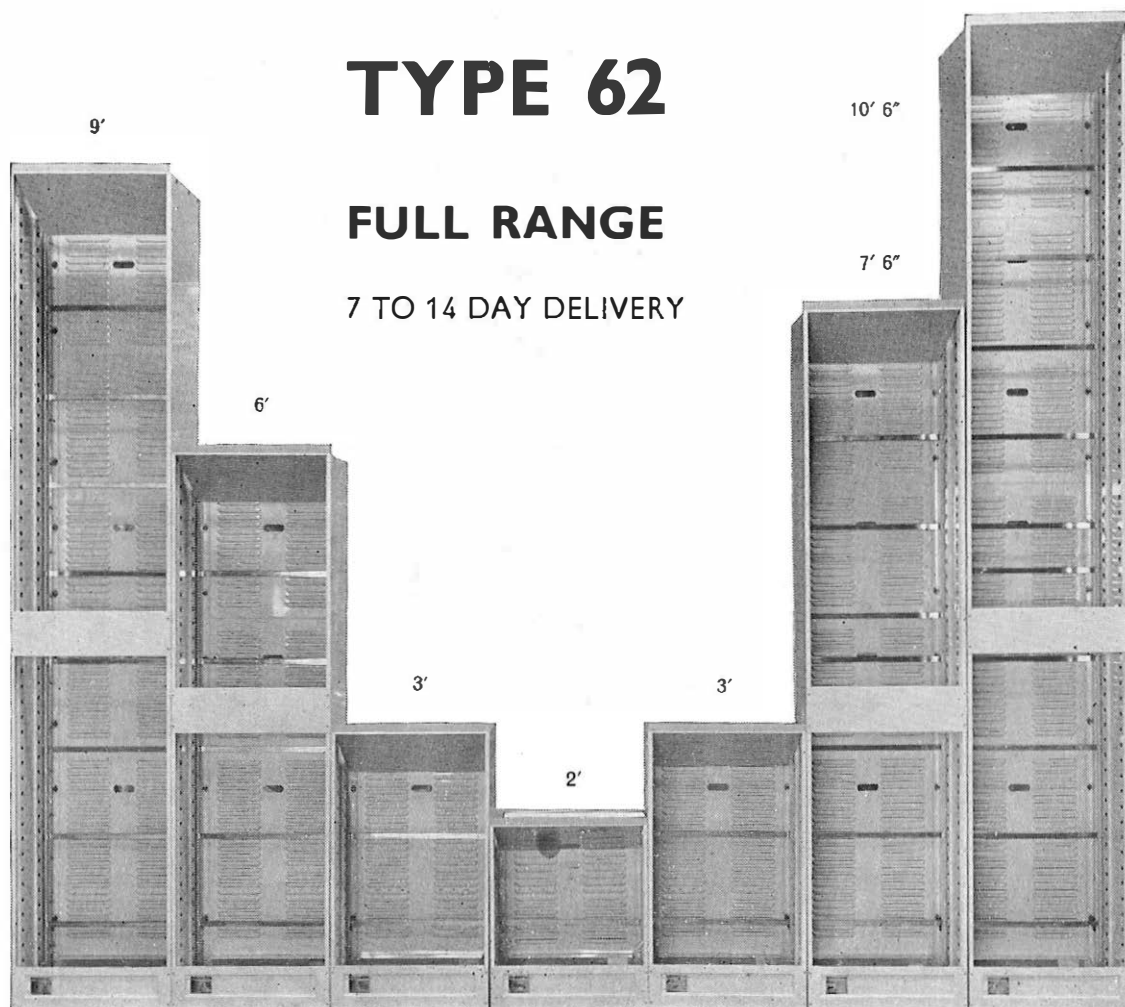

# TYPE 62

## FULL RANGE

7 TO 14 DAY DELIVERY

### HIGH PRECISION MECHANICS

FOR INSTRUMENT ELECTRONIC AND AUTOMATION INDUSTRIES

TELECOMMUNICATIONS  
MECHANICS

**G.P.O. APPROVED**

IMMEDIATE QUOTATIONS AND  
TECHNICAL SERVICE

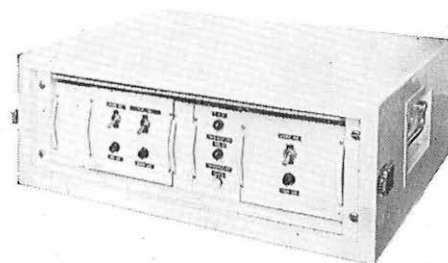

SHELF ASSEMBLIES

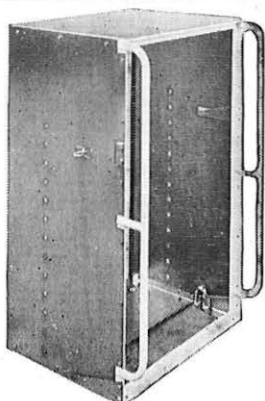

P.C.M. TRANSIT JIG



DATA MODEM

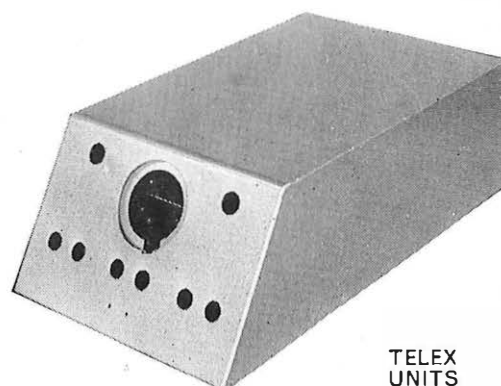

TELEX  
UNITS

# CRAY ELECTRONICS LTD

THAMES ROAD, CRAYFORD, KENT  
TELEPHONE: CRAYFORD 26526