

THE POST OFFICE ELECTRICAL ENGINEERS' JOURNAL



Vol. 57 Part 2

JULY 1964

CONTENTS

	Page
SWITCHING ARRANGEMENTS FOR INTERNATIONAL SUBSCRIBER DIALLING OF CALLS TO EUROPE—J. V. Miles and M. G. Turnbull, A.M.I.E.E.	75
A PHOTO-ELECTRIC DEVICE FOR MEASURING CABLE DIAMETER DURING EXTRUSION—A. C. Lynch, M.A., B.Sc., and E. A. Speight, Ph.D.	79
RESISTANCE-BRAZING AND MOULDING EQUIPMENT FOR USE ON POLYTHENE-INSULATED SUBMARINE COAXIAL CABLES—B. Ash and G. H. C. Green.	82
A TRANSISTOR HEARING AID FOR BONE-CONDUCTION RECEIVERS—D. F. Rigby and D. C. Jones.	86
MOBILE NON-DIRECTOR TELEPHONE EXCHANGES—J. W. Fitch.	89
A MULTI-CHANNEL VOICE-FREQUENCY TELEGRAPH SYSTEM USING TRANSISTORS—R. T. G. Sallis.	95
A REMANENT RELAY—POST OFFICE RELAY TYPE 18.	100
PRIMERS FOR PAINT SYSTEMS—A. D. Walker, A.R.I.C.	101
SUBMARINE-CABLE EARTH-ELECTRODE SYSTEMS—J. R. Walters and G. B. Fernie.	105
THE NEW SUBMERGED-REPEATER CABLE SYSTEM BETWEEN ENGLAND AND GERMANY	109
A CORDLESS TELEX SWITCHBOARD—R. F. Howard, B.Sc.(Eng.), A.M.I.E.E.	110
THE SUPERSESSION OF U.A.X.s 13 BY SMALL NON-DIRECTOR EXCHANGES—A. H. Hunt, A.M.I.E.E.	117
SOME RELIABILITY STUDIES ON SILICON PLANAR TRANSISTORS—F. F. Roberts, B.Sc.(Eng.), A.M.I.E.E., R. Sanvoisin, B.Sc., A.Inst.P., and Patricia M. Morgan, B.Sc., D.I.C.	122
A PORTABLE EMISSION TESTER FOR HOT-CATHODE MERCURY-VAPOUR RECTIFIERS—S. J. Sellwood and R. R. Kirkby.	128
THE CLEANSING OF TELEPHONES.	131
JOINTING OF CABLES CONTAINING TYPE 174A SMALL-DIAMETER COAXIAL PAIRS—H. E. Robinson and F. W. Angell.	132
NOTES AND COMMENTS.	136
INSTITUTION OF POST OFFICE ELECTRICAL ENGINEERS.	137
REGIONAL NOTES.	139
ASSOCIATE SECTION NOTES.	141
STAFF CHANGES.	144
BOOK REVIEWS.	78, 85, 94, 104, 108, 121, 130, 136, 146

Price 3s. (Post Paid 4s.)

Published in April, July, October and January by *The Post Office Electrical Engineers' Journal*,
G.P.O., 2-12 Gresham Street, London, E.C.2.

Annual Subscription (post paid): Home, 16s.; Overseas, 17s. (Canada and U.S.A., 2 dollars 75 cents).

THE POST OFFICE ELECTRICAL ENGINEERS' JOURNAL

Vol. 57 Part 2

JULY 1964

Switching Arrangements for International Subscriber Dialling of Calls to Europe

J. V. MILES and M. G. TURNBULL, A.M.I.E.E.†

U.D.C. 621.395.65:621.395.373 :621.395.741

Facilities have now been provided for subscribers connected to London director-area exchanges to dial direct to certain European countries. The switching and trunking arrangements at the London international automatic exchange are described and reference is made to the method of obtaining the necessary international accounting information.

INTRODUCTION

THE majority of the telephone circuits to Europe are now operated on a semi-automatic basis, outgoing calls being established on demand by the London operator without the intervention of an operator in the distant country. The logical extension of this service is to provide facilities to enable subscribers to dial each other direct, and plans have been prepared over a number of years for the introduction of international subscriber dialling (I.S.D.). During 1963 facilities were provided to enable subscribers on certain London exchanges to dial direct to subscribers in Paris, using modified Signalling System A.C. No. 9 (S.S.A.C. No. 9) equipment.¹ Equipment has now been provided to permit subscriber access to European routes equipped with the standard C.C.I.T.T.* international signalling equipment.²

The design of the subscriber trunk dialling (S.T.D.) register-translator equipment provided in director areas caters for the routing and charging of I.S.D. calls, and I.S.D. is being provided initially in London; it will shortly be introduced in provincial director areas, using direct circuits to the international automatic exchange in London. The arrangements at non-director centres for I.S.D. are being planned and will be applied at a later date.

In a previous article on the introduction of international subscriber dialling³ reference was made to the allocation of 2-digit country codes by the C.C.I.T.T. for countries in Europe and in the Near and Middle East. Consideration has since been given by the C.C.I.T.T. to a world-wide numbering plan, and proposals have been made to enable the whole of the world to be linked in a single numbering scheme. This plan is

based on the principle of allocating a single digit each for North America and the U.S.S.R., 2-digit codes for the majority of other countries and 3-digit codes for the smaller countries. It is also proposed that the trunk prefix digit of the objective country (0 for the United Kingdom) should not be considered part of the international number and should not be dialled by the calling subscriber. These proposals are subject to ratification at the Plenary Assembly of the C.C.I.T.T. to be held in 1964.

The digits 010 in the national-numbering plan have been allocated for I.S.D. access for United Kingdom subscribers. These digits, followed by the country-code digits and the national number of the wanted subscriber, omitting the trunk prefix, will constitute the complete number dialled by the calling subscriber. The country code allocated to the United Kingdom is 44; hence, a London subscriber with a national number 01 ABC 1234 would have an international number 54 1 ABC 1234.

FACILITIES AND TRUNKING ARRANGEMENTS AT THE INTERNATIONAL EXCHANGE

Access to the switching equipment at the London international automatic exchange is provided by direct circuits from the centralized S.T.D. units. Circuits from the London Citadel S.T.D. unit are provided on a 2-wire basis, but from the other London S.T.D. units 4-wire amplified circuits are used to prevent any additional transmission loss in the connexion. Access from the provincial director centres will be provided over direct 4-wire circuits utilizing S.S.A.C. No. 9.⁴ A new type of S.S.A.C. No. 9 incoming relay-set, which caters for the extension of the transmission path on a 4-wire basis, will be provided at the international automatic exchange for routes from provincial director centres.

Trunking Arrangements

The trunking arrangements of the equipment provided at the international automatic exchange are shown in the figure. Register-access relay-sets are connected to the outgoing international circuits by a marker-controlled link-circuit switching system in which each link consists of two 100-outlet motor uniselectors. This system is the same as that employed for the switching of

†Telephone Exchange Systems Development Branch, E.-in-C.'s Office.

*C.C.I.T.T.—International Telegraph and Telephone Consultative Committee.

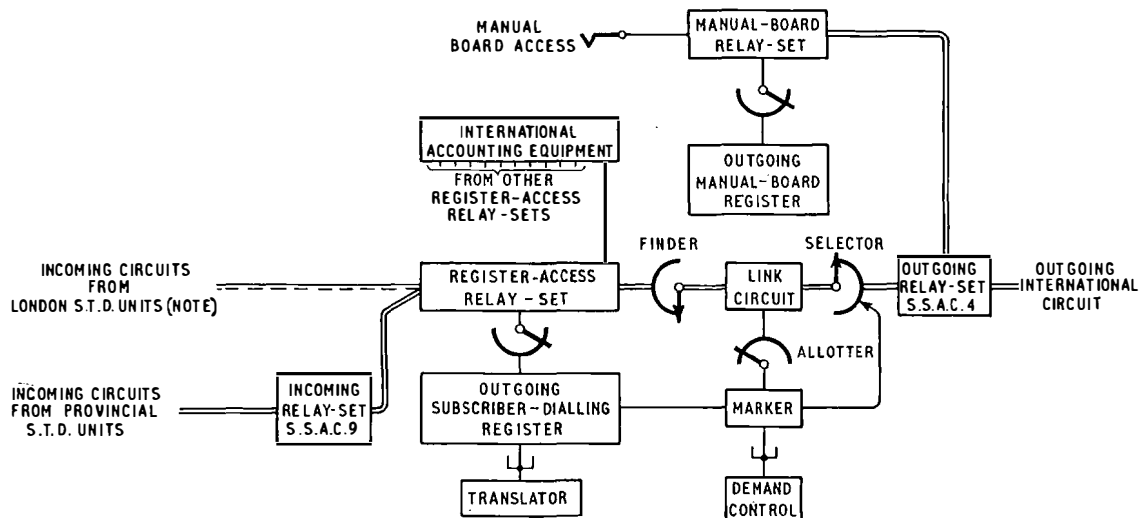

Note: Incoming circuits from London S.T.D. units are 4-wire except for those from the London Citadel unit.
TRUNKING ARRANGEMENTS AT THE LONDON INTERNATIONAL EXCHANGE

transoceanic telephone circuits.⁵ The unit caters for a maximum of 1,500 incoming and 1,500 outgoing circuits, arranged in 15 incoming and 15 outgoing sections each having a capacity of 100 circuits.

The trunking arrangements permit joint access to the outgoing international circuits by subscribers and operators, but, in practice, a certain number of circuits will be restricted to either subscriber or operator access.

International Accounting

International agreements on the settlement of accounts make it necessary to keep records of the chargeable duration of all calls on every international route. The revenue received for a call is shared on an agreed basis with the incoming country and any other country through which the call is routed. On operator-controlled calls full details of the route taken and the call duration are recorded on tickets prepared by the operator at the international exchange. These tickets provide the information from which both the charge to the subscriber and the payment to be made to other Administrations are determined. On an I.S.D. call the charge is recorded on the subscriber's meter in his local exchange, as for an S.T.D. call, the periodicity of the metering pulses being determined by the centralized S.T.D. equipment. Associated with the register-access relay-sets at the international automatic exchange is electronic equipment with magnetic-drum stores on which are recorded the chargeable duration and route-destination of all I.S.D. calls. Information on the country of destination and the route selected, i.e. the route-destination, is sent from the international register to the accounting equipment during the setting-up of each fully-automatic call.

Register-Access Relay-Set

The register-access relay-set is designed for either a 2-wire or 4-wire input; in relay-sets used for 4-wire working the 2-wire/4-wire terminations are replaced by transformer-type transmission bridges.

On seizure of the register-access relay-set the associated register hunter searches for a free register. The register hunters are non-homing and incorporate a step-on feature which ensures that, under normal conditions,

a different register is used on a repeat attempt to set up a call. An extended inter-digital pause of 1,400 ms is given by the S.T.D. originating register between the last routing digit and the first digit of the international number to allow time for the association of the international register with the access relay-set. Should a register not be associated when the first digit is received by the access relay-set, due to register congestion conditions, busy tone is connected to the incoming junction and the circuit for the register hunter is disconnected. On association of a register the digits received from the S.T.D. equipment are repeated to the register as earth-disconnect pulses.

An individual lead is provided from each access relay-set to the international accounting equipment, and over this lead is signalled the seizure of the relay-set, routing information from the register, the called-subscriber-answer condition and the release of the relay-set. These signals are sent sequentially as earth-disconnect pulses, the lead being extended to the register for the sending of the routing information.

Storage of Digital Information

Following the sending of the digits necessary to route the call to the international automatic exchange the S.T.D. controlling register repeats the country-code digits and the national number of the required subscriber. These digits, sent as loop-disconnect pulses at 10 p.p.s. with shortened inter-digital pauses of 330 ms, are received at the international automatic exchange by the register-access relay-set and repeated to the register. The digits are converted to binary code by a group of eight relays and transferred to digit-storage relays during each inter-digital pause, provision being made for storing up to 15 digits.

Translator

Associated with the registers is a common group of translators, access to a free translator being obtained via a translator hunter in each register. Due to the number of leads needed to associate a register with a translator, the translator hunters are used for testing purposes only. On switching to a free translator, a

group of connecting relays in the register, corresponding to the selected translator, is operated, and contacts of these relays connect the remaining leads between the register and the translator.

Following receipt of the fifth digit the register is associated with a free translator and the first five digits stored in the register are signalled to the translator in binary code. The five digits received by the translator are converted to decimal form and expanded to give a discrete marking on one of a number of code tags. The first digit is expanded to mark one of 10 code tags; these points are expanded by the second digit to 100 tags.

Provision is made for further expansion of a limited number of codes according to the third and fourth, or the fourth and fifth digits. The additional expansion is required to cater for 3-digit country codes and where access is provided to more than one international switching centre in a particular country. In order to determine the routing to a country with more than one international centre it is necessary to examine the first and possibly the second digit of the national number. Provision has been made to cater for the alternative requirements that either the trunk prefix digit should be included as part of the international number, or omitted if the C.C.I.T.T. proposal referred to previously is ratified.

A translation relay is allocated for each route-destination and is connected to the appropriate code tag. The contacts of the translation relay are connected to cross-connexion fields to give the following routing and accounting information to the associated register:

- (a) The outgoing section required and, therefore, the marker to be used.
- (b) The portion of the outgoing-section multiple giving access to the outgoing route.
- (c) An indication of whether a terminal-seizure or transit-seizure signal should be transmitted.
- (d) A sending instruction to indicate a 2-digit or 3-digit country code.
- (e) The choice of route and the charging zone in the country of destination.

This information is extended to the register in coded form, and, after checking the receipt of valid signals, the register releases the translator.

A route-busy relay is connected to all outgoing relay-sets in each route, and when the last circuit is taken into use the corresponding route-busy relay in the translator is operated. Contacts of the route-busy relay provide for either the operation of a different translation relay, to give access to an alternative route, or the return of a route-busy signal to the register.

Accounting Information

Information concerning the routing of the call is sent as earth-disconnect pulses at 14 p.p.s. to the accounting equipment from the register, via the access relay-set. The first two digits of the country code are sent as soon as the second digit has been stored in the register. On receipt of further information from the translator a digit representing the charging-zone in the country of destination is sent, followed by a choice-of-route digit. For a call to a country having a 3-digit country code the third digit of the country code is sent instead of the charging-zone digit. If congestion occurs on an outgoing route

the country-code digits and the charging-zone digit are followed by the digit 8 in place of the choice-of-route digit, to signify congestion. This enables a record to be kept of the number of occasions when congestion is encountered on calls to any particular destination.

Outgoing-Section Marking

A marker is associated with each outgoing section and marking is, therefore, carried out with respect to the outgoing section. Each outgoing section has a capacity for 100 outgoing circuits, which may be divided into 15 different groups of circuits.

The access relay-set indicates to the register on seizure the incoming section to which it is connected. The register, on receipt of the routing information from the translator, applies for the marker associated with the required outgoing section. It then extends the routing information to the marker, identifying the incoming section from which the call originated and the portion of the outgoing multiple. To ensure that only one marking condition is applied to any one incoming section at the same time, the marker makes an application to a demand-control relay-set associated with that incoming section.

Link-Circuit Association

On receipt of a signal from the demand-control relay-set a start signal is extended, via the link-circuit allotter serving the link-circuit group concerned, to a pre-allotted free link circuit. Simultaneously with the connexion of a start signal to the link circuit, the marker extends a marking signal to the selected group of circuits on the selector side of the link circuit; the marker also extends a marking signal, via the register and access relay-set, to the finder side of the link circuit. The selector of the link circuit hunts for a free outgoing relay-set in the marked group whilst the finder searches for the marked access relay-set. When the finder and selector have found their respective outlets a link-circuit-associated signal is given to the access relay-set, and this is repeated to the register. On receipt of the signal the register releases the marker, which then disconnects the start signal from the allotter and the demand-control relay-set.

Sending the Digital Information Over the International Circuit

Following link-circuit association, signalling wires are extended from the outgoing international line circuit via the access relay-set to permit the register to control the transmission of v.f. signals by the outgoing Signalling System A.C. No. 4 (S.S.A.C. No. 4)² relay-set. For a call established over a direct route a terminal-seizure signal will be transmitted, and when this signal has been acknowledged by a terminal proceed-to-send signal, transmission of the digital signals commences. Digit 0 is transmitted as an initial digit in place of the language digit* in order to indicate to the incoming terminal that the call is subscriber dialled, i.e. fully automatic, and no end-of-pulsing signal will be received. The digit 0 is followed by the national number of the required sub-

*Language digit—A language digit is a digit from 1 to 9 which determines the service language that must be used on the connexion, i.e. the language that an assistance operator at an incoming international terminal must speak when assisting on a call established by semi-automatic operation.

scriber, which, as mentioned previously, does not include the trunk-prefix digit.

Should the call be set up via an international transit centre a transit-seizure signal will be sent initially and this will be acknowledged by a transit proceed-to-send signal. The country-code digits, one, two or three digits depending on the route, will then be transmitted to the international switching centre. On receipt of these digits a route will be selected from the transit switching centre either direct to the country of destination or to another international transit switching centre. The equipment has been designed to permit routings that involve two transit centres, and when a second transit proceed-to-send signal is received the country-code digits are repeated. When an incoming register is associated with the incoming circuit in the country of destination a terminal proceed-to-send signal will be returned, and on receipt of this signal the international register at London will transmit the digit 0 followed by the national number of the required subscriber.

Provision has been made for the connexion to be released and a repeat attempt made to establish the call should the international register detect a signalling or switching failure; under these conditions only one repeat attempt is made. Should a failure occur on the repeat attempt the register is released and busy tone is returned from the access relay-set to the calling subscriber.

Release of the International Register

When the incoming register in the distant country detects that it has received a complete number, a number-received signal is returned. On receipt of this signal the controlling international register releases and the speech path of the international circuit is extended via the access relay-set to the calling subscriber. Supervisory tones should then be received from the distant national network.

When the called-subscriber-answer signal is received at London, it is repeated to the originating S.T.D. centre and it causes metering conditions to be applied at the meter-pulse rate previously selected. A called-subscriber-

answer signal is also given by the access relay-set to the international accounting equipment, which commences to record the chargeable duration of the call.

In order to reduce the ineffective holding time of international circuits forcible release is applied by the register-access relay-set if an answer signal is not received within 2-4 minutes of the release of the register or if a called-subscriber-held condition persists for 1-2 minutes: the international circuit is released and number-unobtainable tone is returned to the calling subscriber by the access relay-set.

CONCLUSIONS

The equipment described in this article was brought into service in April 1964 when I.S.D. service was provided for subscribers served by exchanges in the London director area having S.T.D. facilities, enabling them to dial direct to subscribers in Western Germany, Holland, Belgium and Switzerland. The service will be extended to include access from provincial director areas later this year, and access will be given to additional international routes when agreement has been reached with the respective Administrations. The Paris circuits which were given an interim I.S.D. service using modified S.S.A.C. No. 9 equipment have been converted to S.S.A.C. No. 4 working, and standard I.S.D. access is now given to most of the cities and towns of France.

References

- ¹ MILES, J. V. Introduction of International Subscriber Dialling from the London Director Area to Paris. *P.O.E.E.J.*, Vol. 56, p. 33, Apr. 1963.
- ² TURNBULL, M. G. Introduction of Semi-Automatic Operation of Continental Telephone Services. *P.O.E.E.J.*, Vol. 52, p. 89, July 1959.
- ³ MAURER, C. J. Dialling of International Trunk Telephone Calls by United Kingdom Subscribers. *P.O.E.E.J.*, Vol. 54, p. 92, July 1961.
- ⁴ MILES, J. V., and KELSON, D. Signalling System A.C. No. 9. *P.O.E.E.J.*, Vol. 55, p. 51, Apr. 1962.
- ⁵ HEPTINSTALL, D. L., and JONES, P. F. Switching Arrangements for Semi-Automatic Operation of Transoceanic Telephone-Cable Circuits. *P.O.E.E.J.*, Vol. 56, p. 105, July 1963.

Book Review

“Der Entwurf von Filtern mit Hilfe des Kataloges normierter Tiefpässe.” (The Design of Filters using the Catalogue of Normalized Low-Pass Filters.) R. Saal. Telefunken, GmbH. 381 pp. 30 D.M.

Well over two decades have passed since it became known how to design reactance filters which, operated between resistive terminations, will meet specified attenuation requirements with the smallest number of components. In spite of more recent refinements, it is still a time consuming exercise for the expert and even more so for the engineer not specialized in this field. It is therefore a great relief to all concerned that this excellent volume of tables has been compiled covering a wide range of filters.

The attenuation characteristics of all the filters included are of the often-required variety which has ripples of equal minima in the stop band. The tables give, in the first instance, the element values of impedance-symmetrical and antisymmetrical low-pass ladder filters of the 4th to 9th degree, i.e. of $1\frac{1}{2}$ to 4 sections. The transformation into high-pass

and band-stop filters can easily be carried out. There is a set of tables for each symmetrical case, while the antisymmetrical filters are covered twice over for different terminating conditions. Each set consists of 10 to 11 tables for various maximum values of the reflection coefficient in the pass band, equivalent to prescribed attenuation ripple amplitudes. The individual tables have an entry which is related in a simple manner to the gap between pass band and stop band. The element values are normalized with respect to pass-band frequency limit and terminating impedance so that the actual values can easily be computed for any practical condition.

The book is published in Germany, but English readers are offered an adequate translation of the introduction (A very comprehensive survey paper published earlier by the author and one of his colleagues in the I.R.E. Transactions gives ample background for those who are interested in it). The well-laid-out tables are inter-lingual thanks to the time-honoured application of an Arabic invention; a comma indicates the decimal point. A few non-realizable cases where negative elements occur are included, but this will hardly cause confusion.

J.M.L.

A Photo-Electric Device for Measuring Cable Diameter During Extrusion

A. C. LYNCH, M.A., B.Sc., and E. A. SPEIGHT, Ph.D.†

U.D.C. 621.383 : 531.717.1 : 621.315.2

A photo-electric device has been designed to monitor the diameter of a polythene-insulated cable core as it emerges from the extrusion machine, where the use of mechanical measuring devices is impracticable. Cable cores up to 1·1 in. in diameter are measured consistently and reliably to an accuracy of about 0·001 in.

INTRODUCTION

THE diameter of the polythene-insulated cores of modern submarine cables must lie within narrow limits and, therefore, to reduce the risk of producing appreciable amounts of faulty cable before any error in diameter is detected, a continuous check must be made close to the point where the cable leaves the extruder. Since the insulation remains soft and sticky for about 1 min after leaving the extruder, it is impracticable to use a measuring device that touches the cable; an optical device, which does not do so, therefore has great advantages. Furthermore, in passing through the measuring device, the cable will usually move slightly both sideways and up-and-down; it is easier to avoid false indications due to such movements in a properly designed optical instrument than in a mechanical one.

In an early measuring device, the cable obscured part of a fixed beam of light, and the light in the unobstructed part of the beam was compared with that which passed through an adjustable standard aperture. The instrument was normally worked in a balanced condition, but it was found to tolerate only a very small and inadequate range of adventitious movements of the cable and to be thrown out of balance by any partial obstruction of the beam of light, e.g. by condensation of fumes on a lens. The instrument described here is relatively immune from such effects because it depends on a measurement of time instead of light intensity, and it has been used successfully in the manufacture of many thousands of miles of submarine cable.

DESCRIPTION

Optical Unit

Fig. 1 is a schematic diagram of the optical unit. The two right-angled prisms (G) serve no essential function but, by folding the optical path, permit a considerable reduction in the overall size of the unit. The two cylindrical lenses (B and J) also are not theoretically necessary but confer important practical advantages. First, they permit the use of smaller prisms and smaller and simpler lenses (I) in the rotating lens-wheel (H), and, in these and other ways, permit the use of a much smaller lens-wheel than would otherwise be necessary. Secondly, they increase the overall optical efficiency and so permit the lamp (A) to be considerably under-run, thereby reducing its liability to premature failure. For simplicity, these lenses are ignored in the following

description of the operation of the device; their functions are discussed in greater detail elsewhere.¹

Referring first to the arrangement denoted Type 1 in Fig. 1, the lamp (A) and condenser lens (C) produce

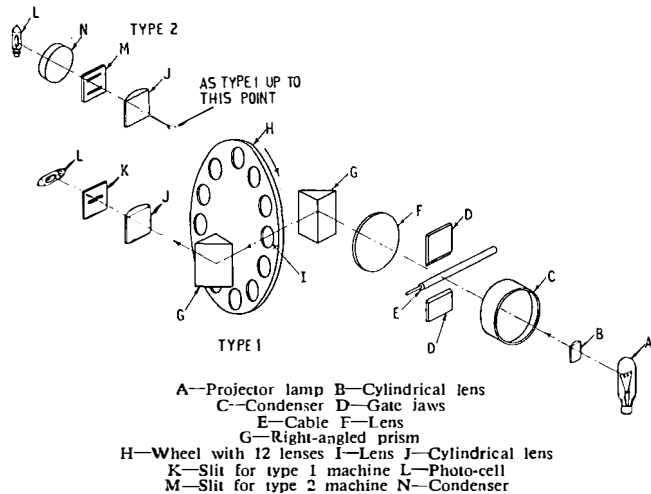

FIG. 1—SCHEMATIC DIAGRAM OF OPTICAL UNIT

a beam of parallel light which uniformly illuminates an area that includes the inner portions of the jaws (D) of the optical "gate" and the cable (E), which normally lies in the plane of, and midway between, these jaws. At any instant, the fixed lens (F) and one of the lenses (I) in the rotating lens-wheel form an image of the region of the gate, including the cable, at the slit (K). As the lens-wheel rotates at 400 rev/min, a succession of images (one for each moving lens) of this region is swept across the slit, and the following sequence of events is repeated 80 times per second at the photo-cell:

(a) Darkness when the image of the upper jaw of the gate falls on the slit.

(b) Light when the image of the space above the cable falls on the slit.

(c) Darkness when the image of the cable falls on the slit.

(d) Light when the image of the space below the cable falls on the slit.

(e) Darkness when the image of the lower jaw of the gate falls on the slit.

The main advantage of the system, which has been patented,² is that the photo-cell and the subsequent amplifier, etc., are used not to measure the light intensity reaching the cell but primarily simply to distinguish

¹LYNCH, A. C., and SPEIGHT, E. A. A Photo-Electric Device for Measuring Cable Diameter During Extrusion. *Proceedings I.E.E.*, Paper No. 3916M, June 1962 (Vol. 109, Part A, Supplement No. 3, p. 134).

²LYNCH, A. C. and SPEIGHT, E. A. Improvements in or relating to Measurement by Optical Means. British Patent No. 791,813.

†Post Office Research Station.

between darkness and light. In effect, the instrument is adjusted so that, with a cable of correct diameter lying in the gate, the total duration of light (stages (b) and (d)) is equal to the total duration of darkness (stages (a), (c) and (e)) in each cycle.

Assuming the lens-wheel to rotate at constant speed, the period of each cycle is constant. The length of each individual dark interval ((a), (c) and (e)) and, therefore, the total duration of darkness, is independent of the instantaneous position of the cable in the plane of the gate. It follows that the total duration of light is similarly independent, though, if the cable changes position, the duration of stages (b) and (d) will vary in a mutually complementary fashion. The overall light-to-dark balance is therefore independent of the instantaneous position of the cable, and the use of integrating circuits in the amplifier preserves the balance if the cable moves up or down.

Since, in practice, the slit cannot be infinitesimally narrow, as successive images are swept over it the various light-to-dark and dark-to-light transitions are not instantaneous but gradual. If the cable moves sideways or slantwise, its image ceases to be sharply focused on the slit and the gradualness of the transition is increased. Provided certain optical conditions are satisfied and the electronic circuit is set to operate always at the same point in the transition stage—the mid point is actually chosen—it can be shown that the light and dark times remain the same as if the transitions were truly sharp. For all practical purposes, therefore, the balance point of the apparatus is independent both of sideways and vertical movement of the cable. The essential optical condition (discussed more fully in reference 1) is that each light-to-dark or dark-to-light transition should be a linear penumbra, and this is satisfied if the lamp filament is set exactly at the principal focus of the condenser lens. An adjustment is provided to achieve this setting initially; the use of lamps with pre-focus bases ensures that it is retained without further adjustment when a lamp is changed.

Fig. 2 shows the complete optical unit as set up for

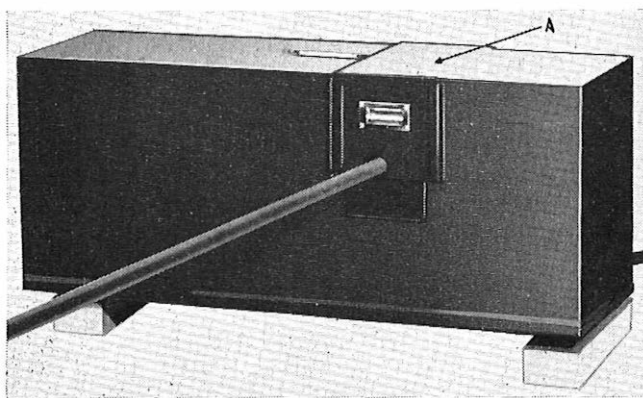

FIG. 2—OPTICAL UNIT WITH CABLE

use with a cable passing through it; Fig. 3 shows the internal construction with the various parts lettered as in Fig. 1. The portion A (Fig. 2) of the cover can be removed and the gate retracted so that the instrument can, if desired, be placed in position while the cable is running. A full range of mechanical adjustments is provided so that the gate can be set in the correct

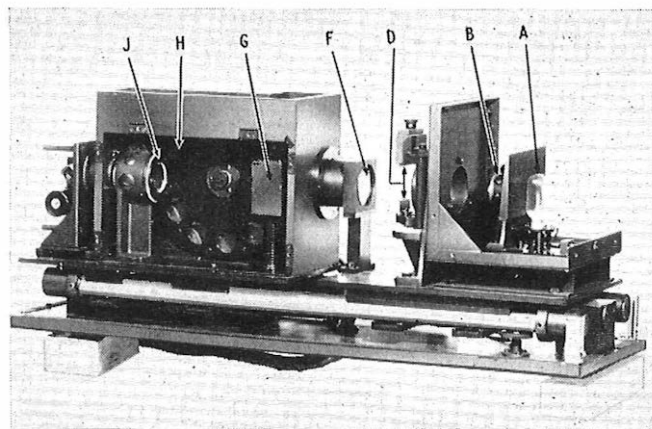

FIG. 3—TYPE 1 OPTICAL UNIT WITH INTERNAL COVERS REMOVED

position relative to the mean path of the cable, but the only optical adjustment necessary is that for setting the separation of the jaws of the gate to suit the desired diameter of the cable.

Electrical Circuits

The photo-cell and associated amplifier (Fig. 4) must have a good response up to at least 12 kc/s. A vacuum photo-cell is therefore used and, together with the first stage of the amplifier, is contained in a separate screened compartment in the optical unit.

The second stage of the amplifier consists of a pair of valves (V3, V4) in push-pull, amplifying and phase-splitting; the third stage comprises another pair of valves (V5, V6) in push-pull, amplifying and symmetrically limiting. The symmetry of the signals applied to this stage is an essential feature, as it makes the limiting action also symmetrical and causes the instant at which the fourth, or switch, stage of the amplifier changes over to be truly half-way through the penumbra of the original signal (the accuracy of this timing is actually within about 1/30 of the duration of the penumbra).

The fourth stage of the amplifier is a pair of pentode valves (V7, V8) in push-pull, driven by a large input and with large anode loads. Their anodes therefore switch between the high-tension voltage and a voltage of about 40 volts. The fifth or output stage is a pair of cathode-followers (V9, V10) with large cathode loads, acting as d.c. amplifiers for signals obtained through integrating circuits from the anodes of the previous stage. A milliammeter connected between the cathodes of the final stage then indicates any departure from the intended conditions.

In the interests of reliability the valves are of a type designed for use in submerged repeaters; the connexions to the valves are soldered and none passes a mean cathode current greater than 5 mA. The number of components has been kept as small as possible and reliable types have been selected. Through the use of valves in push-pull, decoupling is necessary for only the first two stages of the amplifier. The power supply has duplicated rectifier valves. An alarm is given in the absence of a signal in the final stages, e.g. due to a motor or lamp failure.

The calibration is independent of lamp voltage, photo-cell sensitivity and amplifier gain over a wide range; the balance point is independent also of h.t. voltage.

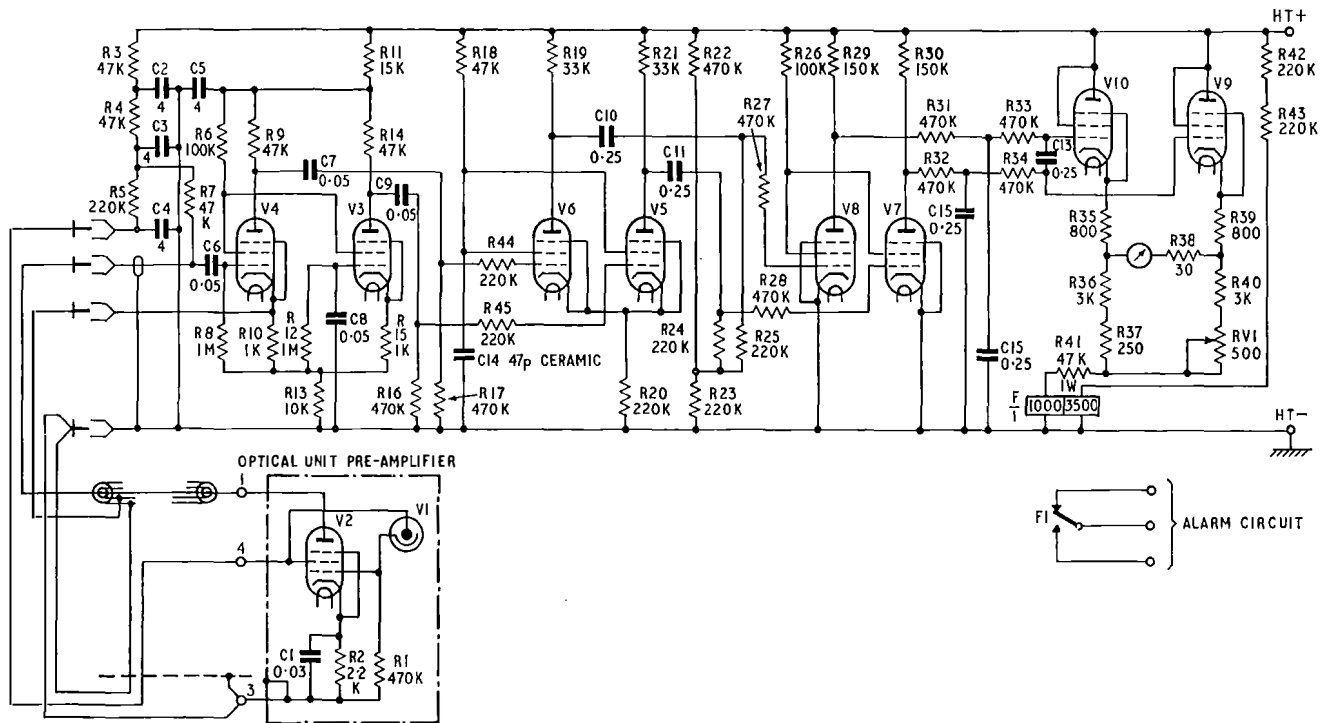

FIG. 4—PHOTO-CELL AND AMPLIFIER CIRCUIT

PERFORMANCE

The apparatus can be adjusted to work with cable of any diameter up to 0.7 in., and covers a range of ± 0.016 in. deviation from normal at any setting; an error of 0.001 in. is easily read. The error in indicated diameter due to a $\pm \frac{1}{4}$ in. vertical movement of the cable does not exceed 0.0005 in.; that due to a similar horizontal movement does not exceed 0.0003 in. The two displacements occurring simultaneously can cause an error up to 0.0009 in. In laboratory conditions, the stability with time is equivalent to an error of not more than about 0.0003 in. on the indicated cable diameter. A change of ± 20 volts in the mains supply causes an apparent change in indicated diameter of about ± 0.001 in. In a cable factory, where large motors are frequently started and stopped, it was found necessary to supply the apparatus through a stabilizing transformer.

The apparatus has now been in use for thousands of hours in factory conditions and has been consistent and reliable in operation.

MODIFICATION FOR LARGER CABLE DIAMETERS

After three machines had been constructed, a need

arose to measure cable diameters up to at least 1.0 in. Without modification of the mode of operation described, this would require a beam of light more than 2.2 in. deep, which is much larger than the existing lenses can accommodate, and a simple substitution of larger lenses would be impracticable.

One contractor using the machine suggested modifying the integrating network in the amplifier so that the balanced condition corresponded to unequal durations of light and dark. This expedient was successful, but the stability of the apparatus, which then depended critically on the ratio of two resistances, was not quite as good as before.

Another method, devised by the authors, was to replace the single slit in front of the photo-cell by two parallel slits and add a collecting lens between the double slit and the cell, as shown in Type 2 of Fig. 1. The geometry of the system is such that each complete scan now produces four separate periods of light instead of two and the apparatus is balanced when the sum of the gaps between the cable and the jaws of the gate is one quarter of the total sweep instead of one half. This system is effective for cables in the diameter range 0.7 - 1.1 in., and the accuracy and stability of the instrument are unaltered but the sensitivity is doubled.

Resistance-Brazing and Moulding Equipment for Use on Polythene-Insulated Submarine Coaxial Cables

B. ASH and G. H. C. GREEN†

U.D.C. 621.791.76+678.027.7:621.315.616.96:621.315.28

The development of long-distance submarine coaxial telephone cables led to the introduction of portable resistance-brazing and injection-moulding equipment so that joints of a very high electrical and mechanical standard could be made. Smaller and cheaper brazing and moulding machines with a wider field of use have now been developed.

INTRODUCTION

DURING the early days of development work on long-distance submarine telephone cables the Post Office Research Station introduced the first portable equipment for resistance brazing and injection moulding.¹ This equipment was very reliable and produced joints of an exceptionally high electrical and mechanical standard. On the first transatlantic telephone-cable installation it was used successfully over a very hazardous cable route across Newfoundland.² Subsequent expansion of the submarine telephone-cable network, incorporating land sections of submarine cable, and the experience gained using the original equipment, have led to the possibility of an extension in the use of brazing and moulding techniques and the design of smaller and cheaper equipment.

The expensive operations involved in the repair of submarine cables make it essential to use equipment and methods of proven integrity. The installation of transoceanic telephone cables, from the first transatlantic cable (TAT-1)³ to the latest, the Commonwealth Pacific cable (COMPAC),⁴ has provided much of the opportunity and experience for developing the machines described in this article.

RESISTANCE-BRAZING EQUIPMENT

The resistance-brazing machine, illustrated in Fig. 1,

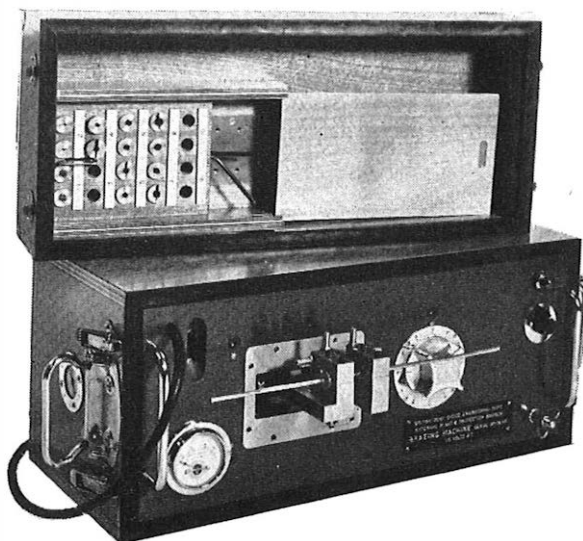

FIG. 1—RESISTANCE-BRAZING MACHINE

†External Plant and Protection Branch, E.-in-C.'s Office.

consistently produces joints of near parent-conductor strength in any type of submarine coaxial-cable centre conductor; it can also be used to cut the high-tensile steel centre-strand of Lightweight submarine coaxial cable.⁵ The power supply required is 110 volts a.c., which can be provided by either mains or a mobile-alternator source. The machine consists of the following main components:

- (a) Power transformer.
- (b) Selector switch.
- (c) Operating switch.
- (d) Brazing jaws.
- (e) Movable-jaw control.
- (f) Brazing collets.

Power Transformer

To allow the voltage across the secondary winding to be changed, the power transformer has 10 tappings on its primary winding. The secondary winding is a single turn of heavy-gauge double-leaf copper-strip, one end of which is terminated directly on a fixed brazing jaw. A laminated flexible copper-strip connector terminates the other end of the secondary winding on a movable jaw. This flexible connexion facilitates adjustment of the gap between the brazing jaws.

Selector Switch

The selector switch is of the rotary type and provides means for the selection of any one of the 10 tappings on the primary winding of the power transformer. With the brazing machine wired for 110-volt working, the voltage across the jaws at each of the 10 switch positions is arranged as follows:

Switch Position	Voltage Across the Brazing Jaws
1	0.44
2	0.47
3	0.53
4	0.60
5	0.71
6	0.86
7	1.09
8	1.24
9	1.41
10	1.64

Operating Switch

The operating switch, which is a double-pole non-locking type, is fitted in the primary circuit of the transformer. It has high current-carrying capacity, gives reasonable manual control of the brazing time, and speedily breaks the circuit when released.

Brazing Jaws

One of the brazing jaws is fixed while the other has lateral movement. Both jaws are sufficiently robust to support and maintain the alignment of the conductors during brazing operations. They have water-cooling

facilities and a ready means of clamping different brazing collets. The movable jaw is spring-loaded and can be set to give lateral forces from 0-35 lb. The material (brass) and construction of the jaws ensure a low-resistance path for the brazing current.

Movable-Jaw Control

The movable-jaw control is a means by which the spring-loaded brazing jaw can be moved laterally by a cam from the front of the brazing machine. It provides the following facilities:

(i) Adjusts the distance between the brazing jaws to allow the jointer to insert the brazing metal between conductors.

(ii) Retains the spring pressure on the movable jaw while the conductors are being positioned for brazing.

(iii) Transfers the pressure from the cam to the conductors when they are ready for brazing.

A cut-out switch is associated with the movable-jaw to automatically switch off the brazing current. This allows the brazing time to be under manual or automatic control—an advantage when resistance brazing certain types of conductor.

Brazing Collets

The design and provision of brazing collets eliminates the need for costly sets of independent brazing jaws to suit each conductor size. Two pairs of collets are required to facilitate the clamping of a conductor in the brazing jaws, and seven sets of these collets are provided with each machine. These allow resistance brazing of conductors ranging in size from seven strands of 0.032 in. diameter to single-strand 0.260 in. in diameter. High-tensile steel strand, a feature of Lightweight submarine-cable centre-conductor jointing, can also be cut electrically on the brazing machine, and a set of collets is also provided for this operation.

MOULDING EQUIPMENT

Early moulding equipment was designed for use on factory floors, on the decks of cable ships, or in laboratories. The advent of extending long-distance submarine cables from beach joints to terminal stations well inland introduced new problems in handling moulding equipment, e.g. carrying out moulding operations in the limited space of jointing chambers, in many instances in proximity to existing cables of the inland telephone network. The first efforts to meet these conditions involved a re-design of the then existing hydraulically operated moulding machines. This re-design resulted in the control unit of the machine being separated from the injector unit, but, while this change allowed cables of early schemes to be jointed successfully, it was never entirely satisfactory, because the cost of preparing jointing chambers to house the equipment was very high. The equipment was cumbersome and difficult to manipulate in the confined spaces available, and the general handling was a problem both in jointing chambers and on the highways when loading on and off jointers' vehicles.

Moulding Machine

The new moulding machine, illustrated in Fig. 2, is considerably cheaper than the hydraulic type, and is much smaller and lighter. High-quality moulded-core

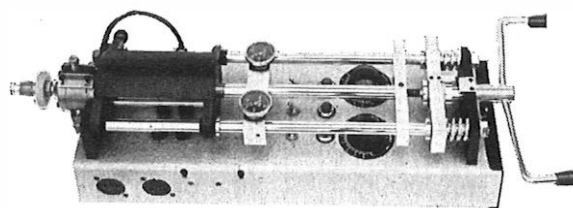

FIG. 2—MOULDING MACHINE

joints have been successfully made with this machine on submarine-cable coaxial cores of 0.310 in., 0.460 in. and 0.620 in. diameter. The machine consists of the following main components:

- (a) Base.
- (b) Injector barrel.
- (c) Barrel-extension piece.
- (d) Nozzle assembly.
- (e) Ram assembly.
- (f) Electrical control circuits
- (g) Carrying case.

Base. The base is a long shallow box-shaped chassis of sheet metal in which is housed the wiring and all the electrical components for switching, fusing, heating and pilot lighting. Socket outlets are provided in the sides of the base to connect power to the electrical pump of the cooling-water unit and to the cartridge heaters of the double-injection mould. Mounted on top of the base is the injector barrel, the barrel-extension piece, and the nozzle and ram assemblies. Cut in the side of the base are mounting holes to carry the electrical pump of the cooling-water unit.

Injector Barrel. The stainless-steel injector barrel is secured at each end to plates fitted between two circular guide-bars. These plates swivel on one guide-bar and slot into a retaining collar on the other. The injector barrel can thus be lifted to allow polythene charges to be inserted into it. Unlike earlier machines, in which heat zones were fitted on the injector barrel, this barrel is unheated and the polythene, therefore, remains solid, preventing creep-back over the piston.

Barrel-Extension Piece. The barrel-extension piece is 2 in. long and is heated on the outside by a 300-watt band-heater. Together with the nozzle assembly, it is held in position on the end of the injector barrel by 4 in. long Allen screws. The temperature of the polythene passing through the barrel-extension piece is measured accurately with a Rototherm bi-metal dial-type thermometer the stem of which extends into a brass tube screwed into the top of the barrel-extension piece.

Nozzle Assembly. The end of the nozzle assembly has a ground seating to fit the mould, and it is locked in position by a threaded male thimble.

Ram Assembly. The ram assembly enables a thrust of from 0-1,200 lb to be imparted to the piston that is used to force polythene through the heated extension piece and then through the nozzle assembly into the mould. This injection pressure is obtained by turning an enclosed square-threaded screw to compress two horizontally fitted springs. These springs push the piston, via the ram, evenly and smoothly into the injector barrel with such force that an adequate injection pressure is developed; this pressure is, of course, dependent upon the degree of compression given to the springs, and upon the cross-sectional area of the piston. A calibrated

scale indicates the force in pounds exerted by the springs upon the ram.

Electrical Control Circuits. Normal 2-wire switching and fusing is provided to each individual control circuit. The period for which the current flows in the circuit serving the mould and barrel-extension piece can be regulated individually by Sunvic energy regulators. A red pilot lamp gives a visual display during the period that the Sunvic control allows the current to flow. Bypass resistances are provided in parallel with each pilot lamp and these maintain the current to the mould and band heater on the barrel-extension piece in the event of failure of either pilot lamp.

Carrying Case. The carrying case (Fig. 3) is made of marine plywood, with all outside corners protected with

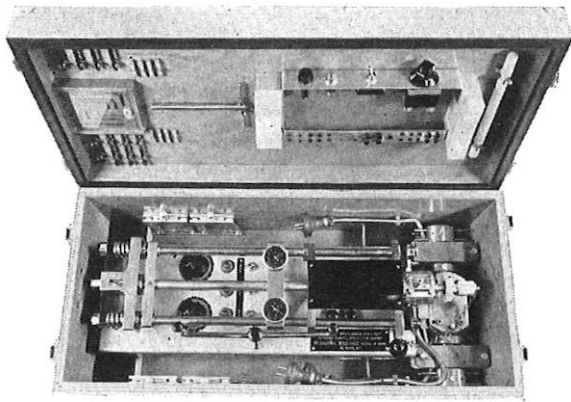
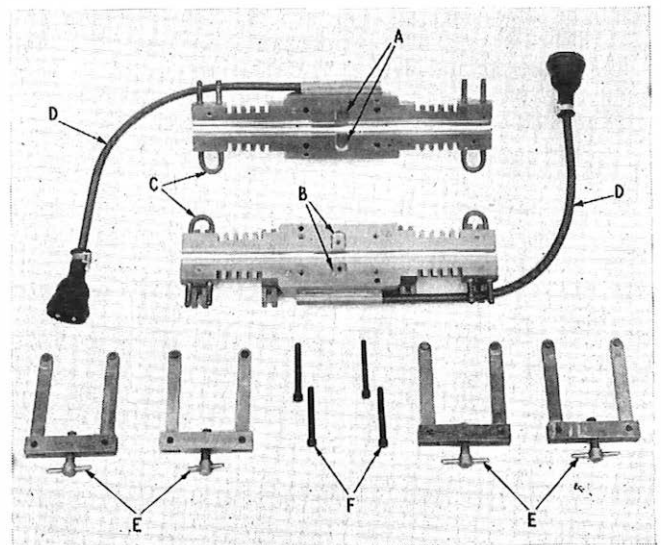

FIG. 3—MOULDING MACHINE IN CARRYING CASE

metal. On the outside ends of the case two carrying handles are fitted, and four locking-type clips are provided to hold on a completely detachable lid. The inside of the case is fitted to hold the moulding machine and one mould. Quick-release clamps associated with the mould are also carried in the case and are held securely, two on each side, by spring clips. Inside the lid of the carrying case are retainers holding mechanical and electrical spares, e.g. fuses and spare Allen screws of the type used in the construction of the equipment. Two shaped clamping blocks are fitted to the lid to prevent movement of the moulding machine when the lid is in position.

Double-Injection Mould

A typical double-injection mould for use with the new moulding machine is shown in Fig. 4 and 5. Each mould is made for a particular coaxial-core size. The mould is heated by four 200-watt cartridge heaters, two in each half, and the electrical connexions are protected by flexible Terry spring-tubing. The necessary heat gradient from the peak-temperature zone to the mould ends is obtained by air cooling with graded-depth finning; the mould ends are water cooled. One half of the mould contains the female socket to accept the nozzle of the moulding machine, and the mould entries are designed to give double-injection ports, one above and one below the centre conductor. The other half of the mould has blanked matching ears. This system of double-injection acts in the same way as a breaker plate does in a conventional moulding machine using single-



A—Blanked matching ears B—Double injection ports C—Cooling-water tubes
D—Power leads E—Quick-release c'amps F—Allen screws
FIG. 4—DOUBLE-INJECTION MOULD

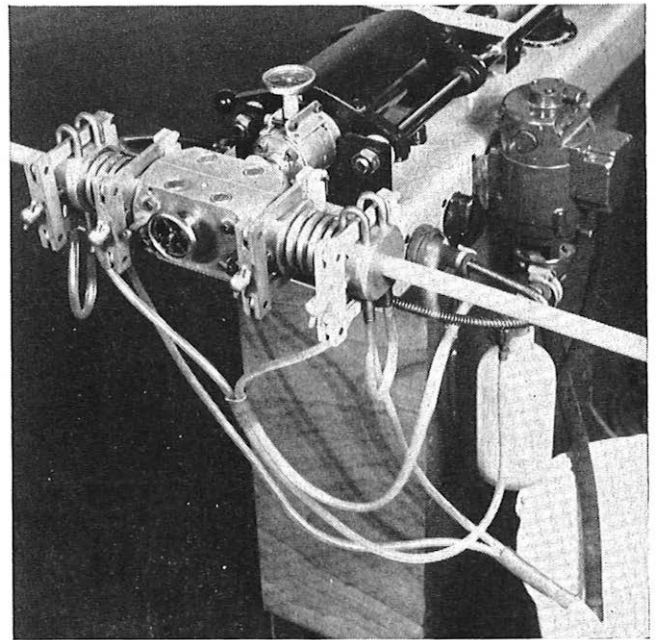

FIG. 5—DOUBLE-INJECTION MOULD IN USE

injection type moulds. A Rototherm thermometer is fitted to give accurate direct readings of the mould temperature. Both halves are clamped together in the centre section by four Allen screws and four suitably spaced quick-release clamps. Facilities are also provided for breaking the mould by two Allen screws in case sticking occurs after the completion of the moulding process.

Cooling-Water Unit and Carrying Case

The complete cooling-water unit fitted into its carrying case is illustrated in Fig. 6. The unit is fitted to a moulding machine as shown in Fig. 5. The unit continuously circulates water through the ends of the mould

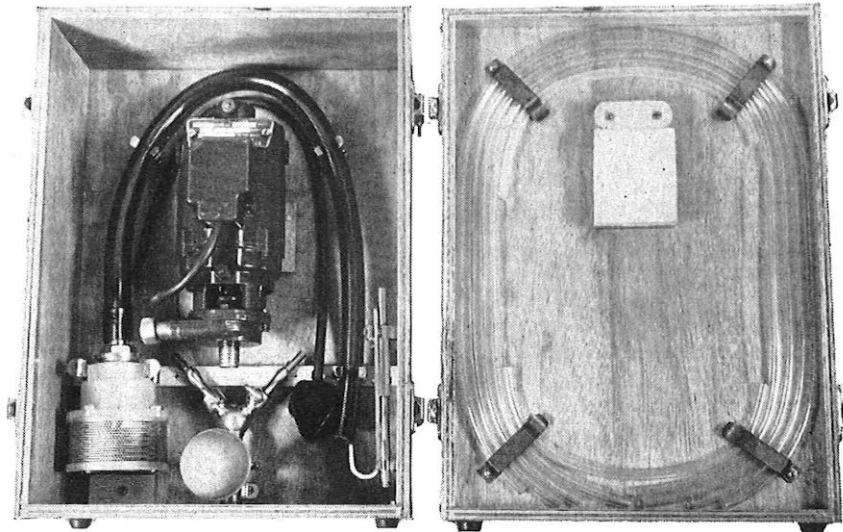

FIG. 6--COOLING-WATER UNIT IN CARRYING CASE

to prevent softening and swelling of the polythene core adjacent to the mould ends. The unit consists of a 60-watt electric pump that draws water through a strainer from a bucket. A special distributor fitted to the outlet of the pump feeds the water, via plastic pipes, to each end of the mould, the water being returned to the bucket via similar plastic pipes. Fitted to the special distributor is a rubber bulb to prime the pump and start the water circulating.

The pump carrying-case is made of marine plywood, and all external corners are protected with metal. Four standard box-fasteners are used to secure the lid, and a leather handle strap is fitted for carrying purposes. The inside of the box also carries all the necessary accessories. A 2-gallon polythene bucket holds sufficient water for the cooling requirements.

CONCLUSION

The equipment described has been used on cable

ships and on many projects in this country, and has been supplied to many administrations for use overseas. However, it will be necessary for future equipment, which is at present being developed, to cover a wider range of cable sizes to include the larger cores of 0.990 in., 1.000 in. and 1.500 in. which may be used in the majority of future submarine-cable systems.

References

- ¹HALEY, G., and COSIER, J. E. H. The Jointing of Polythene-Insulated Coaxial Cables. *P.O.E.E.J.*, Vol. 51, p. 22, Apr. 1958.
- ²ROBINSON, H. E., and ASH, B. Transatlantic Telephone Cable—The Overland Cable in Newfoundland. Vol. 49, p. 1 and p. 110, Apr. and July 1956.
- ³The Transatlantic Telephone Cable. *P.O.E.E.J.*, Vol. 49, Part 4, Jan. 1957.
- ⁴Inauguration of the Commonwealth Pacific Cable (COM-PAC). (In this issue of the *P.O.E.E.J.*)
- ⁵BROCKBANK, R. A., CLARKE, E. F. S., and JONES, F. Anglo-Canadian Transatlantic Telephone Cable (CANTAT): Cable Development, Design and Manufacture. *P.O.E.E.J.*, Vol. 56, p. 82, July 1963.

Book Review

"Ultrasonic Delay Lines." C. F. Brocklesby, B.Sc., A.R.C.S., A.M.I.E.E., J. S. Palfreeman, and R. W. Gibson, B.Sc. (Eng.), Grad.I.Mech.E. Iliffe Books, Ltd. 297 pp. 168ill. 65s.

For many purposes it may be necessary to delay the arrival of electrical signals for predetermined intervals of time, and if the required delay is more than a few microseconds it can most easily and economically be achieved by using the comparatively low propagation speed of acoustic disturbances in an elastic medium. Such acoustic delay systems all use an electromechanical transducer to convert the electrical signal into an acoustic wave train which is converted back into the original electrical signal after traversing a path of suitable length in a solid or liquid elastic medium. The "ultra" of the title above refers to the frequencies of the acoustic waves, usually of the order of megacycles.

These devices have been in use for about 25 years, but this appears to be the first book wholly devoted to them.

There was therefore a great deal of ground to cover, and this the authors have done in a manner both logical and exhaustive. And indeed exhausting: this is no book for the hopeful beginner, but rather for the improver and physicist already actively engaged on the work.

Thus, Chapter 2 gives an excellent summary of the theory of waves in acoustic media, though it seems that the section on Electromechanical Analogies could well have been expanded. Chapter 3 outlines the theory of transducers, and is very heavy going indeed. The next three chapters give the theory and practice of the three most used types of line: liquid, solid and wire; anyone who has mastered Chapter 3 should find no difficulty here. There is an excellent chapter on associated electronic circuits, one on measurements and one of applications.

Finally, there are 5 appendices, compact references, and a host of curves giving the characteristics of line and transducer materials. Altogether, this is an excellent text and reference book—for the worker already engaged in the field.

A.W.M.C.

A Transistor Hearing Aid for Bone-Conduction Receivers

D. F. RIGBY and D. C. JONES†

U.D.C. 621.395.92:621.382.3

Following the production of the monopack transistor hearing aid for use with insert earphones, attention has been given to the needs of National Health Service patients who require bone-conduction receivers. The development of a more powerful transistor aid for this purpose has been completed in collaboration with a manufacturer, and production is now fully under way.

INTRODUCTION

TOWARDS the end of 1960 the transistor monopack hearing aid previously described* was made available to National Health Service patients, and it has now practically replaced the older valve model. There are, however, about 20,000 people for whom an air-conduction aid is not suitable, their only effective means of sound reception being by bone-conduction. Stimulation for these patients is achieved by means of a receiver having a solid face-plate curved to fit snugly over the mastoid bone and held firmly in place under tension by a spring-steel headband. The electrical power needed for adequate sensation is of the order of 10 times that required for air-conduction, and this necessitated the provision of a completely new hearing aid.

DESCRIPTION

The aid, which is shown in Fig. 1, consists of a microphone, transistor amplifier and a battery of two Leclanché cells, contained within a single body-worn case and connected to a bone-conduction receiver by means of a plug-ended flexible lead. The weight is approximately 3½ oz, without the receiver and its headband.

Case

The air-conduction monopack aid is contained in a plastic case; it has been criticized from time to time on account of the number of case breakages that occur, particularly at the hands of young children. It was, therefore, decided to offer to the Ministry of Health two equivalent aids, one housed in a more robust plastic case and the other in a metal case. The final choice of the Ministry was for a metal case.

The anodized-aluminium case is in three sections, giving easy access to the component panel and simplifying the microphone sealing-gasket problems. The lower section of the front is removable and gives access to the battery compartment, which houses two RO3-size cells. A wire dress-clip was chosen as being more in line with modern trends, and this can be changed by the clinic personnel either to the front or to the rear of the aid to suit individual needs.

†Mr. Rigby is in the Telephone Electronic Exchange Systems Development Branch, E.-in-C.'s Office, but was in the Subscribers' Apparatus and Miscellaneous Services Branch when this article was written. Mr. Jones is in the Subscribers' Apparatus and Miscellaneous Services Branch, E.-in-C.'s Office.

*THWAITE, H., and ASPINALL, E. A Transistor Hearing Aid. *P.O.E.E.J.*, Vol. 52, p. 163, Oct. 1959.

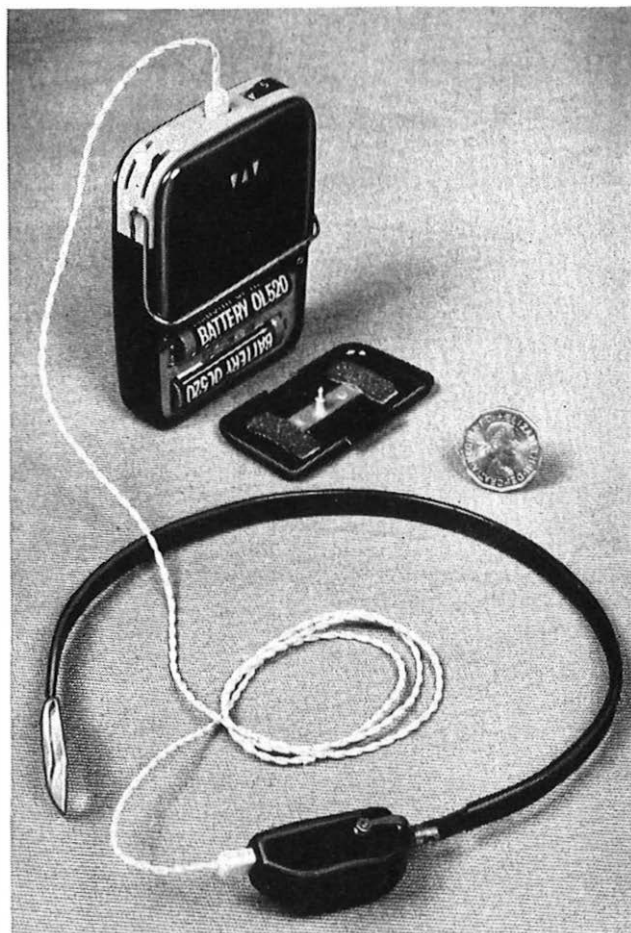

FIG. 1—TRANSISTOR-TYPE BONE-CONDUCTION HEARING AID

Volume Control and ON/OFF Switch

All previous hearing aids designed for the National Health Service have the ON/OFF switch combined with the volume control. Apart from component economy, this arrangement has the advantage that an aid cannot be set to maximum gain and then switched on. Such an action, which could apply full output suddenly to the user, might, in the case of patients with less severe hearing loss, cause some distress. With the bone-conduction hearing aid there was the problem of housing a 2-pole switch within the volume control. This was found to be impracticable, and a separate ON/OFF switch had therefore to be provided. This is permissible, however, as there is no risk of a user receiving an excessive sensation level with a bone-conduction receiver.

Inductive Pick-up

The new aid contains an inductive pick-up device similar to that described in the earlier article dealing with the air-conduction hearing aid. The pick-up coil,

instead of the microphone, can be connected to the input of the amplifier to enable electrical input signals, derived, for example, from magnetic-radiation loop-systems in school classrooms, to be received. A 3-way switch at the top of the aid can be set to give either microphone or coil reception; the third switch position combines the two.

DEVELOPMENT OF THE AMPLIFIER CIRCUIT

The complete circuit of the bone-conduction hearing aid, with its receiver, is shown in Fig. 2.

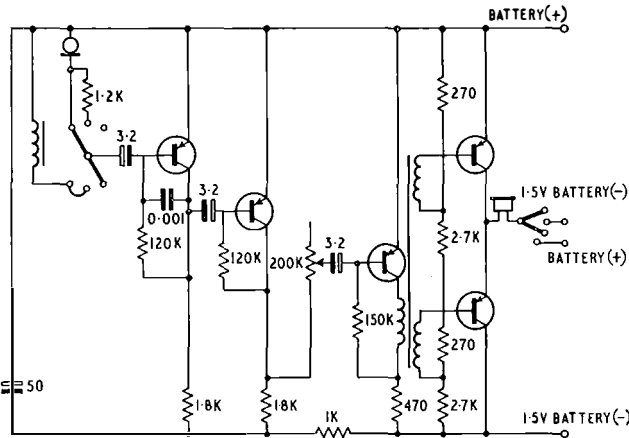

FIG. 2—CIRCUIT DIAGRAM OF HEARING AID

Output Stage

An ever-present consideration in hearing-aid design is the size, life and cost of batteries. For reasons of battery economy a class-B push-pull output stage was chosen. A conventional type of circuit using an output transformer was rejected because a loss of about 3 db of power in the transformer was expected. Another circuit considered was a centre-tapped receiver coil, but the need for 3-way plugs and sockets made this unattractive.

The circuit finally adopted (see Fig. 2) avoids the above-mentioned disadvantages. It uses two 1.5-volt Leclanché-type cells and, with a 40-ohm load impedance, develops 20 mW of electrical power, with a distortion of less than 5 per cent, when new batteries are used and provided that the output transistors are accurately matched for current gain. In practice, with the battery voltage at 1.3 volts per cell and with transistors having the maximum out-of-balance allowed by their specification, the corresponding output power is not less than 14 mW.

Forward bias on the transistors is necessary to avoid cross-over distortion, and this results in a nominal quiescent current of 1 mA with a spread of 0.2–5.0 mA under extremes of temperature and component tolerances.

In the early stages of development, thermistors were used to stabilize the quiescent currents against temperature changes, but they were not adopted as it was found that the wide tolerances of both their nominal resistances and characteristics gave overall spreads of current very little different from that obtainable with good high-stability resistors.

Transistors (Type P.O. No. 1) are used throughout the aid, those in the output stage being specially selected to

fall into three groups, with the maximum unbalance of current gain in any two transistors in one group being in the ratio $1:\sqrt{2}$. During assembly the manufacturer ensures that the two output transistors in each aid are drawn from the same group.

Drive Stage

Transformer coupling between the drive transistor and the output stage was adopted as being the most convenient with this type of output circuit and simpler than direct coupling. The collector-current design figure is 1 mA, with a total spread of 0.6–1.4 mA, a minimum current of 0.4 mA being required to drive output transistors of minimum gain. The transformer is necessarily of small dimensions and, with variation of collector current, produces a small variation in the response at the lower frequencies.

Amplifying Stages

The amplifying stages are of conventional design, and little need be said about them. Feedback from battery-line voltages is minimized by the decoupling action of the 1,000-ohm resistor and the 50 μ F capacitor; feedback balance, as used in the air-conduction hearing aid, is impossible due to the rectifying action of the push-pull stage, interference voltages appearing as rectified half-cycle pulses alternately in-phase and 180° out-of-phase with the signal voltage.

The original design used an inverted first stage with the load resistor connected between emitter and positive line, as this arrangement isolates the base of the second transistor from battery-line feedback voltages. During development by the assembly contractor it was found that this circuit suffered from instability due to the high input impedance (to earthy interfering potentials the stage functions as an emitter follower with consequent high input impedance). The more conventional arrangement with decoupling as described above was therefore adopted.

Stability

During development, great care had to be taken in the equipment layout so as to minimize unwanted stray coupling, the most troublesome being that between the microphone coil and all high-current-carrying wires, i.e. the collector and emitter leads of the output stage and leads to the output socket, and even the batteries themselves. Careful attention to the twisting of leads, component arrangements, and to the design of the output socket eliminated this trouble. It was found necessary to screen the battery compartments, and to arrange the connexions so that the current flow in each battery is counter-balanced by a corresponding flow in its own screen.

As an additional safeguard, the amplifier gain at high frequencies is reduced by feedback provided by the 0.001 μ F capacitor connected between the collector and base of the input transistor.

Although the output socket was designed to produce a minimum of magnetic radiation, there still exists enough coupling with the microphone coil to change the amplifier response by about ± 1 db at 1 kc/s, and correct phasing of the microphone is desirable. Microphone polarity is identified during manufacture, and coloured lead-out wires are used for identification pur-

poses. When correctly connected, feedback in the working range is negative and the amplifier is stable.

PICK-UP COIL

The pick-up coil consists of a thin Ferroxcube rod wound with approximately 6,500 turns of fine-gauge wire. The coil sensitivity is such that the aid will give its maximum output in a magnetic field of approximately 7.4×10^{-4} lines/cm².

RECEIVER

The design of the bone-conduction receiver used with this aid is basically the same as that of the receiver used with the corresponding valve-type aid, but the nominal impedance has been reduced from 90 ohms to 40 ohms at 1,000 c/s. The design aim to achieve parity in power sensitivity has, in fact, been slightly bettered in production.

PERFORMANCE

The main design aim was to produce a transistor-type aid with a performance comparable with that of the existing valve-type aid, and it has been possible to provide an electrical output power approaching 20 mW compared with slightly over 10 mW for the valve model. Fig. 3 shows typical sensitivity/frequency characteristics

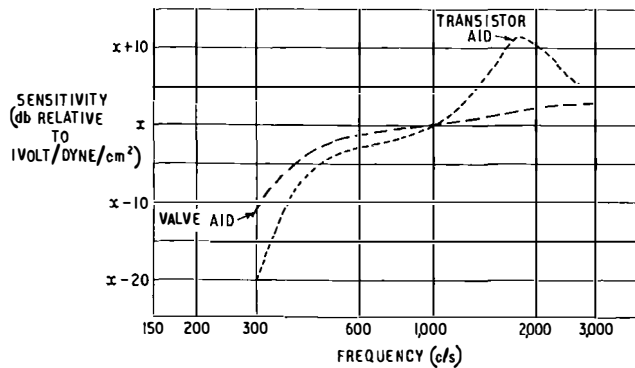

FIG. 3—TYPICAL SENSITIVITY/FREQUENCY CHARACTERISTICS OF VALVE-TYPE AND TRANSISTOR-TYPE HEARING AIDS

for both the valve and transistor aids, measured across their appropriate resistive loads. The slightly improved high-frequency response of the transistor aid is in line with recommendations made by the Electro-Acoustics Committee of the Medical Research Council.

Fig. 4 shows the frequency response of the pick-up coil and amplifier when energized by a loop carrying a constant current.

Fig. 5 shows the frequency response of the bone-conduction receiver with a constant-voltage input measured on an artificial mastoid. For this work the Post Office has adopted a design of artificial mastoid developed by the National Physical Laboratory, several copies of

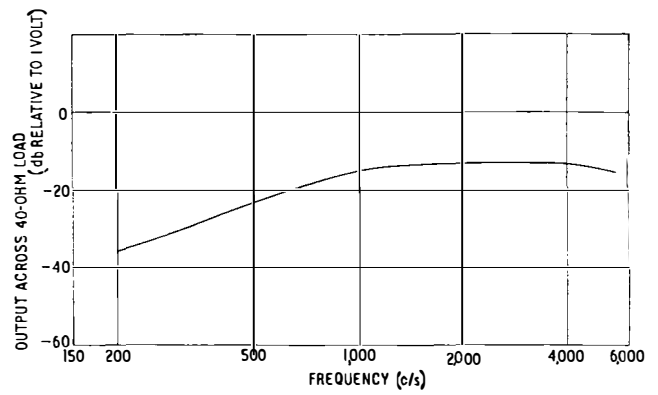

FIG. 4—TYPICAL FREQUENCY RESPONSE OF PICK-UP COIL AND AMPLIFIER

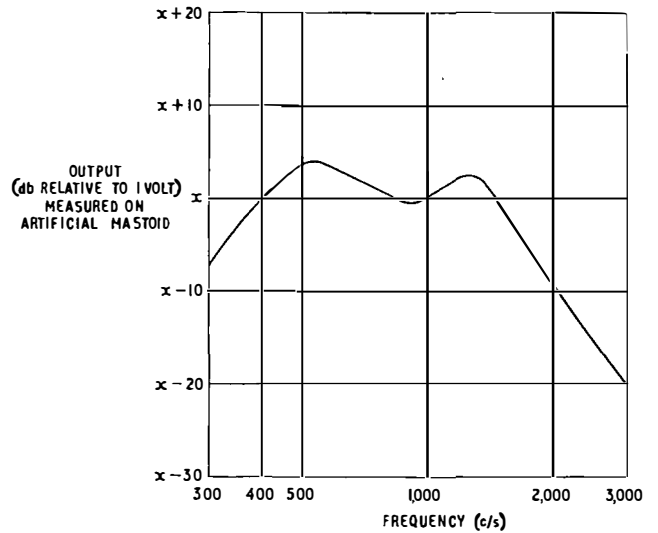

FIG. 5—TYPICAL FREQUENCY RESPONSE OF BONE-CONDUCTION RECEIVER

which have been made. It should be noted, however, that in this figure no correction has been made to take into account the effect of the loading of the particular equipment used for measurement upon the artificial-mastoid output.

ACKNOWLEDGEMENTS

Much of the work on this aid has been done in collaboration with Kolster-Brandes, Ltd., to whom, with colleagues in the Post Office Research Station, acknowledgements are made. The co-operation of the National Physical Laboratory in providing details of the artificial mastoid and arranging check calibrations is also acknowledged.

Mobile Non-Director Telephone Exchanges

J. W. FITCH†

U.D.C. 629.114.3:621.395.722

A fleet of mobile non-director automatic telephone exchanges is being introduced to provide relief for manual exchanges that have become overloaded or whose capacity is exhausted. In many instances such exchanges cannot be extended, and a permanent automatic exchange cannot be provided in time; the use of the mobile equipment described enables a relief exchange with up to a 1,600-line multiple to be brought into service quickly.

INTRODUCTION

A number of the manual exchanges remaining in service are rapidly becoming exhausted or overloaded, and some require immediate relief. It is not possible, in many instances, to give relief economically by means of an extension, and, frequently, the date for conversion to automatic working cannot be brought forward as a means of easing the situation. To meet these conditions it was decided that a new fleet of mobile automatic exchanges should be provided expressly for relief purposes.

This is not a new venture for the Post Office as the first fleet of mobile automatic exchanges (M.A.X.s) was introduced in 1939.¹ These mobile exchanges used unit automatic exchange (U.A.X.) No. 12 equipment with traction-type batteries, and had petrol-engine charging-sets. The equipment, which catered for a 100-line multiple, was accommodated in a single trailer. In 1948 a second fleet of M.A.X.s was introduced using U.A.X. No. 13 equipment. Each of these exchanges is accommodated in two trailers and caters for a 200-line multiple: one trailer, known as section A, houses the C and A units, while section B houses the B units and power equipment, which includes traction-type batteries. These M.A.X.s were primarily intended to be used in civil emergencies and where unforeseen development had occurred.

Two types of mobile non-director exchanges are now being introduced for the relief of manual exchanges that are overloaded or exhausted:

(i) A self-contained non-director exchange in a single trailer, with a 400-line multiple capacity. Initially some exchanges of this type will be equipped for only a 200-line multiple.

(ii) A tandem exchange that can be used in conjunction with the mobile non-director exchange. This type of exchange is also accommodated in a single trailer.

TRAILER DESIGN

The trailer (Fig. 1) used is approximately 22 ft long, 7 ft 6 in. wide and 13 ft high, with the floor level 2 ft 6 in. from the ground. Its design is based on the trailer used for mobile telegraph automatic switching equipment,² with modifications to suit the requirements of the non-director telephone exchanges. The chassis has been constructed to carry a maximum loading of 10 tons, and the two longitudinal bearers are positioned so that the two suites of apparatus racks can be bolted to them.

†Exchange Accommodation and Equipment Branch, E.-in-C.'s Office.



FIG. 1—MOBILE-EXCHANGE TRAILER

The bodywork has been built up using duralumin channel-framing with an exterior cladding of aluminium and an interior lining of peg-board panels; fibre glass has been packed between the inner and outer skins for heat insulation. Ventilation is given by louvres in the sides of the body and a fan built into the body at the towing end. Space heating is also provided by means of tubular heaters fitted at the foot of each rack.

In early types of trailer, timber framing was used, and the interior lining was not perforated. Trailers are normally exposed to the weather when in service, and moisture, deposited by condensation, is trapped in the wall cavities of these earlier-type trailers, causing deterioration of the timber framing. With the new design the metal framing should not be affected, and the rate of evaporation of the moisture is increased by the use of the peg-board lining and by space heating. It is thought that this improved type of coachwork should give long service in the weather conditions met in Britain.

Cable-entry tubes are provided in the floor, and an oblique tube for the power-supply cable is fitted on the near-side, with a supporting eye-bolt for the cable.

The towing arrangements are the normal type with an air-brake coupling. A hand-operated brake is also provided to assist manoeuvring on site. To prevent damage to the tyres, when the trailer is in position on a site, the wheels are removed and hub stands are fitted. These stands, together with a wheel brace, lifting jack and grease-gun, are stored in the trailer during transit. The spare wheel and entrance steps are stored under the chassis.

A special feature of the trailer design is the removable end-panel, which gives a wide apparatus entrance. The door at the side of the trailer is not suitable as an apparatus entrance, and 8 ft 6½ in. racks could not be erected from a horizontal position when inside the trailer. When

the end panel is secured in the closed position a rubber seal ensures that it is completely weatherproof.

EQUIPMENT OF TRAILERS

Non-Director Exchange Unit

A general view of the interior of a non-director exchange unit showing the equipment is given in Fig. 2.

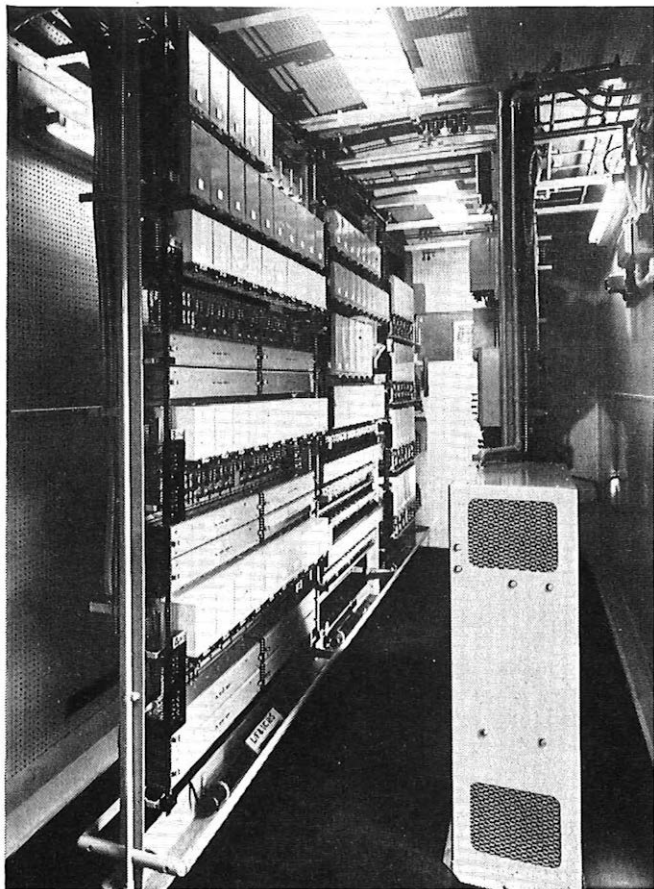
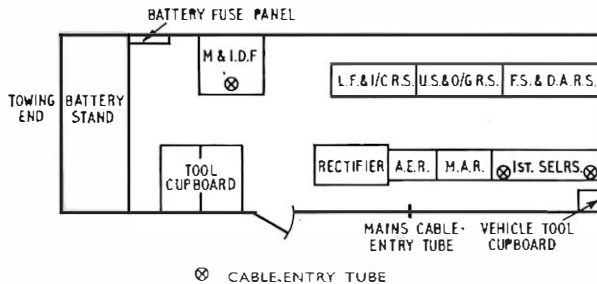

FIG. 2—INTERIOR OF NON-DIRECTOR EXCHANGE UNIT

In the limited accommodation available it is only possible to install the amount of apparatus required for a 400-line multiple exchange by using composite racks. Relay-set shelves are fitted in spare positions on some of the racks that are only partially equipped with their normal equipment. The only completely new item that has been developed for the mobile exchanges is the combined main and intermediate distribution frame (M. and I.D.F.). All the rack designs have been fully documented, and standard common-services diagrams have also been prepared. In fact, apart from the accommodation, the mobile exchange is similar in all respects to a normal non-director exchange. Fig. 3 shows the equipment layout of the mobile non-director exchange unit.

The 50-point linefinder rack³ is equipped with six linefinder groups and two shelves wired for incoming-junction relay-sets. The subscribers' unselector rack is equipped with 100 unselector calling equipments and three relay-set shelves. One shelf is wired for auto-to-auto relay-sets and the other two shelves are wired for



L.F.—Linefinders. I/C R.S.—Incoming-junction relay-sets. U.S.—Uniselectors. O/G R.S.—Outgoing-junction relay-sets. F.S.—Final selectors. D.A.R.S.—Digit-absorbing relay-sets. A.E.R.—Alarm-equipment rack. M.A.R.—Miscellaneous apparatus rack. M. & I.D.F.—Main and intermediate distribution frame.

FIG. 3—LAYOUT OF NON-DIRECTOR EXCHANGE UNIT

outgoing-to-manual-board relay-sets. A shelf wired for digit-absorbing relay-sets has been fitted on the final-selector rack. Spare accommodation on the miscellaneous apparatus rack has been used for the subscribers' and traffic meters, the power switchboard for the 50-volt negative battery, and the rectifier for charging the positive battery. In addition to the normal alarm and pulse-distribution equipment the alarm-equipment rack, shown in Fig. 4, accommodates the pulse-and-ringing machine,

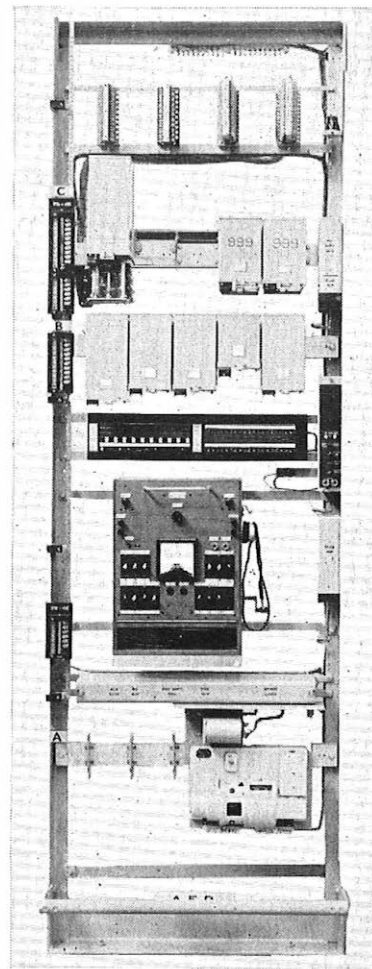

FIG. 4—ALARM-EQUIPMENT RACK

a trunk-offering selector and the maintenance tester. The ringing machine used is a modified version of the Pulse and Ringing Machine No. 1⁴ used at U.A.X.s No. 13.

Because of the limited space available, the combined M. and I.D.F. (Fig. 5) was made as small as possible.

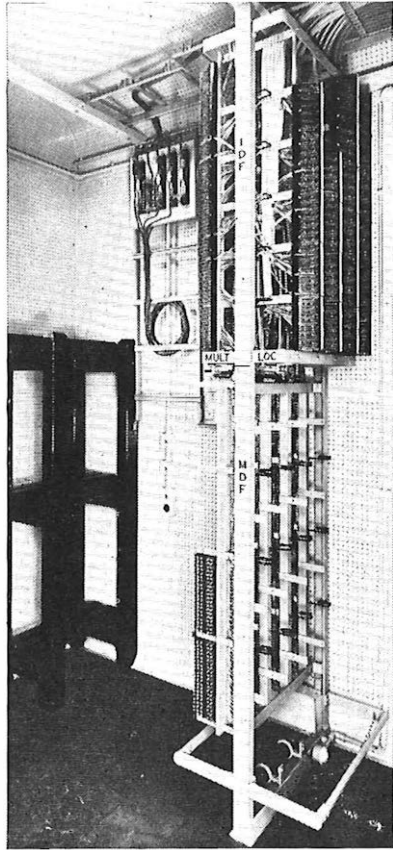
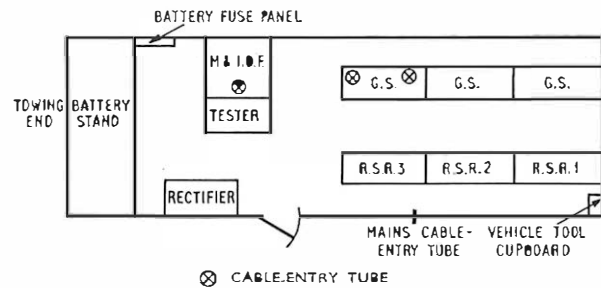

FIG. 5—COMBINED MAIN AND INTERMEDIATE DISTRIBUTION FRAME

Single-sided angled-type connexion strips were used on the I.D.F. so that the frame could be located against the side of the trailer without restricting access for wiring. The I.D.F. part of the frame has capacity for 24 connexion strips on each side. Sixteen fuse mountings can be fitted to the line side of the M.D.F., providing terminations for 640 cable pairs, and a maximum of 400 subscribers' lines, and 240 junctions and miscellaneous circuits can be terminated on the exchange side on 16 blocks of test jacks. The frames are equipped and wired as necessary for each type of exchange, and the fuse mountings are fitted by the local staff when the external cables are terminated.

Tandem Exchange Unit

In the tandem exchanges there are three relay-set racks in one suite (Fig. 6) with a total capacity of 80 auto-to-auto relay-sets and 60 bothway-junction relay-sets; initially only half these quantities of relay-sets are fitted. The second suite consists of three group-selector racks with a capacity of 180 selectors, of which 100 are fitted. No common-services supplies are provided in the tandem exchange unit due to the lack of accommodation for an alarm-equipment rack. The common-



G.S.—Group selectors, R.S.R.—Relays-set rack, M. & I.D.F.—Main and intermediate distribution frame.

FIG. 6—LAYOUT OF TANDEM EXCHANGE UNIT

services required will be extended from the mobile non-director exchange unit with which it will be associated when in service. The power switchboard and the positive-battery rectifier are mounted on relay-set rack No. 3.

Power Plant

To cater for the 50-volt negative supply, with a maximum day-load of 100 ampere-hours, a Power Plant No. 214⁵ has been provided in both the non-director and tandem units, complete with equipment and cabling except for the battery. Similarly, a Power Plant No. 206, without the battery, is provided for the positive supply. The cells required for the batteries are obtained and fitted by the local staff when the exchanges are commissioned. The batteries are not provided as a permanent part of the power plant as they are not traction type and would not stand up to the vibration they would receive when the trailers are towed.

HEATING, LIGHTING AND MAINS SUPPLY

Space heating of both types of exchange is provided by tubular heaters fitted to the bottoms of the racks. The heaters give a total of 780 watts and are automatically controlled by a thermostat set to operate at 34°F and a humidistat set to operate at 64 per cent relative humidity; a time switch is also fitted which will permit up to two hours uncontrolled heating. Additional space heating can be obtained from a 1 kW radiator supplied with each trailer and from the forced-air ventilation system. This forced-air ventilation is given by means of a 2-way fan providing for air intake as well as air extraction. The 1 kW heater associated with the air-intake system can only be switched on when the fan is in operation. The fan is also equipped with washable filter elements. A cover is also provided with each fan so that the ventilation system may be closed completely when this is considered necessary. Because open-type racks have been used in these trailers the mains supply must be connected whether a mobile exchange is in service or in store, so that the controlled heating can be maintained at all times.

The interior lighting is provided by five fluorescent tubes: there are three tubes fitted with reflectors in the apparatus gangway and the other two tubes give lighting on the wiring sides of the suites and are without reflectors. A single switch controls all the lights and is located at the right-hand side of the door.

The power equipment, and the lighting and heating circuits, are arranged to work from a 200–250-volt single-phase 50 c/s supply. An 8-way, 15 amp distribution

board for these services is fitted near the supply lead-in tube. It is mounted on a wall board which also accommodates the humidistat, thermostat and time switch. Protection is catered for by a 250-volt, 30 amp, double-pole, earth-leakage, circuit-breaker, which is also mounted on the wall board.

Miscellaneous Items

The usual cabinet for spare alarm-type fuses and a first-aid store cupboard are mounted above the tool cupboard. A pump-type fire-extinguisher is fitted near the door. A rubber-link mat is provided in a well inside the door and two coat-hangers are fitted near the M. and I.D.F. A small cupboard to house the wheel-jack, brace and grease-gun is located at the rear of the trailer in the near-side wiring gangway. In the non-director exchanges only, a standard tool cupboard and hinged-flap-type desk is accommodated in the space between the door and the battery stand.

CONSTRUCTION

The design and engineering of the exchanges were carried out in the Post Office Engineering Department and a specification was issued giving details of the constructional work. The trailers were equipped and cabled by the Post Office Factories Department with racks and equipment supplied largely from surplus and emergency stocks; some of the surplus equipment required renovation before it was installed. Modifications to certain racks were necessary to make them suitable, including the re-grouping of selector-bank multiples and the complete re-wiring of certain racks. Some of the selectors and relay-sets used also required modification to bring them into line with the latest issue of the circuit diagram.

Due to their height, the trailers could not go into the workshop at the factory and had to be kept in the open. Equipment racks were, therefore, prepared in the factory workshops and then conveyed outside for installation in the trailers. Translucent panelled doors were fitted to the apparatus entrances and were closed when equipment was not being loaded in to the trailers.

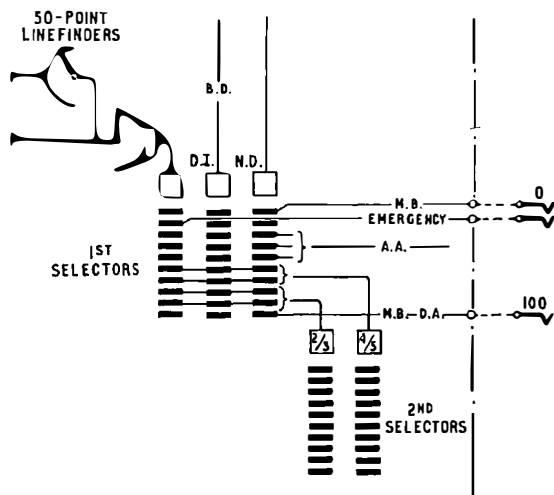

D.I.—Selectors terminating circuits from manual board. B.D.—Battery-dialling relay-sets. M.B.—Manual-board relay-sets. D.A.—Digit-absorbing relay-sets. A.A.—Auto-to-auto relay-sets. N.D.—Selectors terminating circuits from non-director exchanges.

FIG. 7—TYPICAL TRUNKING DIAGRAM OF SINGLE MOBILE NON-DIRECTOR EXCHANGE UNIT

This arrangement gave extra daylight inside the trailers and protection from inclement weather for the staff engaged on cabling and wiring.

The chassis were constructed by Taskers of Andover, Ltd., and the coachwork built by Mann, Egerton and Co., Ltd., to specifications and drawings prepared by the Motor Transport Branch of the Post Office Engineering Department.

UTILIZATION

As already mentioned, mobile non-director exchanges can be used to give relief to exhausted or overloaded manual exchanges. Various combinations of the two types of exchange unit can be used, the particular combination used in any one place being chosen to meet the local conditions, but the mobile exchange will always have a separate identity from the manual exchange it is relieving and have a separate numbering scheme.

The following table shows possible arrangements:

Combinations of Mobile Exchange Units

Number of Non-Director Exchange Units	Number of Tandem Exchange Units	Multiple Size (lines)
1	—	200
1	—	400
2	—	700
2	—	800
2	1	800
3	1	1,200
4	1	1,600

Other multiple sizes are possible using different combinations of the 200-line and 400-line multiple units. A 200-line-multiple exchange can provide service for 188 subscribers, 90 of which will be connected to unselector calling equipments. Similarly, a 400-line-multiple exchange can provide exclusive service for 364 subscribers with 70 of these being connected to the unselector calling equipments. Shared-service subscribers would be connected to the 50-point linefinder calling equipment. Typical trunking arrangements for a single exchange are shown in Fig. 7, and a typical trunking scheme for two exchanges used in association with a tandem exchange are shown in Fig. 8.

When the use of a mobile exchange is being considered, abridged traffic data will be supplied and the details of the exchange design will follow standard principles for non-director exchanges. The trailers are completely cabled and the final connexions necessary to complete the exchange work will be jumper wiring on the combined M. and I.D.F. All the selectors and relay-sets are terminated on the I.D.F., and tie circuits are also provided from the racks to the I.D.F. for grading and interconnexion purposes.

The group-selector racks used are the graded type⁶ with the multiple in three groups of 20 banks and are equipped with 37 selectors (or 24 for a 200-line multiple unit). When a 4-digit numbering scheme is required, one group of 20 selectors will be arranged to be 2nd selectors, and the remaining 40 banks will be used for incoming junctions and local 1st selectors. Similar arrangements may be made in the tandem exchanges to meet the varying needs of different relief schemes.

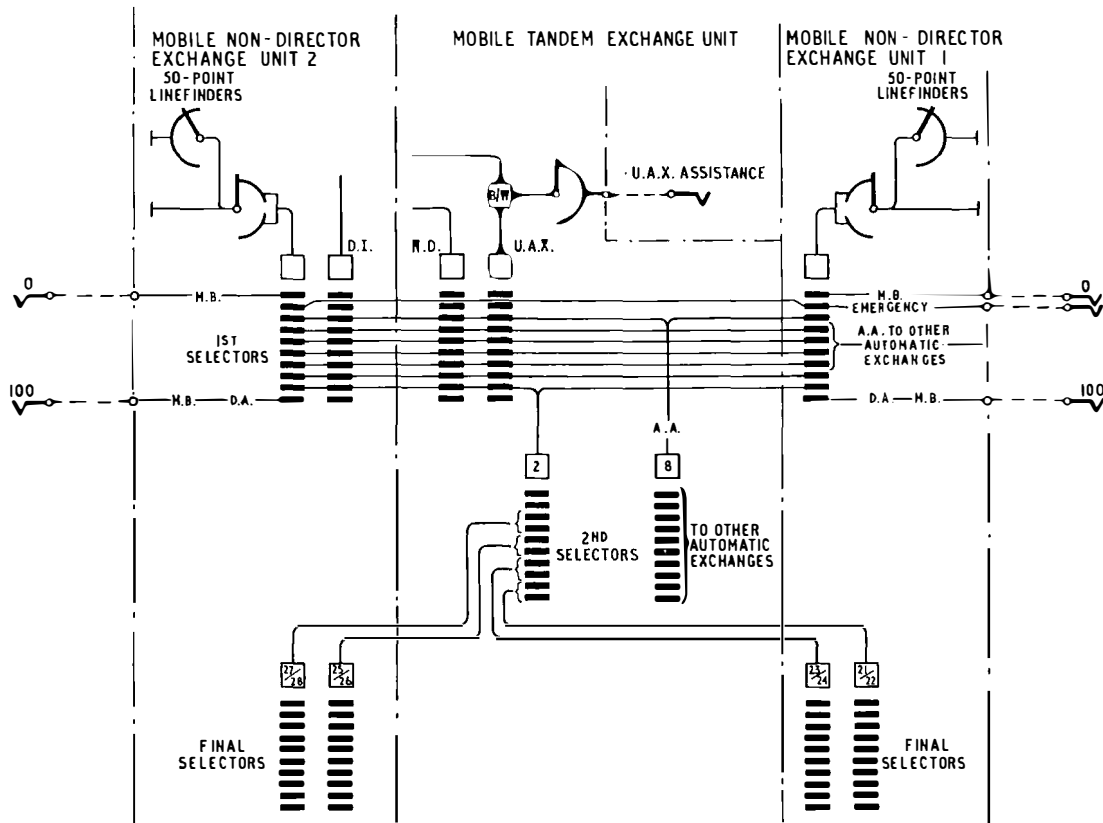

D.I.—Selectors terminating circuits from manual board. N.D.—Selectors terminating circuits from non-director exchanges. B.D.—Battery-dialling relay-sets. D.A.—Digit-absorbing relay-sets. B.W.—Bothway relay-sets. U.A.X.—Selectors terminating bothway circuits from unit automatic exchanges. A.A.—Auto-to-auto relays-sets. M.B.—Manual-board relay-sets.

FIG. 8—TYPICAL TRUNKING DIAGRAM FOR 800-LINE MULTIPLE EXCHANGE COMPRISING TWO MOBILE NON-DIRECTOR EXCHANGE UNITS AND ONE TANDEM EXCHANGE UNIT

All the final selectors are of the 2-10 P.B.X. type, and each exchange has two final-selector groups, each with 20 banks, and is equipped with a total of 24 selectors (or 12 for a 200-line multiple unit). The traffic data will enable a decision to be made on the need to augment the number of selectors fitted or whether the existing provision will suffice for the traffic to be carried.

Access to the manual board for assistance traffic will be obtained from either level 0 or level 1 depending upon the local arrangements. If the assistance-traffic code 100 is used digit-absorbing relay-sets will be obtained and fitted locally on the shelf provided on the final-selector rack.

The subscribers' numbering schemes will depend upon the combinations of exchange units employed and whether 3-digit or 4-digit numbering is used. A typical 400-line-multiple exchange would have a numbering scheme 200-599, or 2,100-2,499. Two or more exchange units would normally have numbering ranges 2,100-2,899 (800-line multiple), 2,100-2,899 and 3,100-3,499 (1,200-line multiple), and 2,100-2,899 and 3,100-3,899 (1,600-line multiple). If two non-director exchange units are used without a tandem unit, the multiple range is restricted if level 1 is used for assistance traffic.

When more than one exchange unit is used, interconnexion between the bank multiples of the 1st selectors is necessary. Tie cables are also required between the tandem 2nd selectors and the final selec-

tors. The 1st-selector bank-multiple tie-circuits form standard inter-rack cabling with the terminations on the connexion strips at the rear of the selector racks. The tie circuits required from the tandem 2nd selectors to the final selectors will be cabled from the 2nd selectors in the tandem exchange to spare tie circuits on the 1st-selector rack in the non-director exchange, with jumper-wire connexions on the I.D.F. in the non-director exchange between the 1st-selector tie-circuits and the final selectors. Two cable-entry tubes are located in the floor behind the 1st-selector racks in the non-director exchange and also behind a group-selector rack in the tandem exchange to provide entry for the tie cables.

The alarms can be extended to an adjacent exchange in the normal manner. If more than one non-director exchange unit is in use on a site, one is made the controlling exchange for the local alarms. The alarm bells in all the exchange units are connected in parallel so that an audible fault indication is given in all trailers.

The mobile exchanges require to be located on a site with a level and firm foundation. Although the site need not be adjacent to the exchange requiring relief, it must be suitable for access to the local-cable network. If more than one exchange unit is being used on a site, a central distribution point will normally be provided near the trailers for the mains supply and the external cables. Feeder cables will be used to connect the supplies and external cable pairs to each trailer.

CONCLUSION

At the present time the Post Office Factories Department are nearing completion of the first order for 30 of these mobile exchanges (24 non-director units and six tandem units) and some are already in service.

References

- ¹PALMER, R. W., and ABBOTT, G. A. O. A Mobile Automatic Telephone Exchange. *P.O.E.E.J.*, Vol. 32, p. 1, Apr. 1941.
²COULMAN, A. H., and GOSS, C. E. G. Emergency Mobile

Teleprinter Automatic Switching Units. *P.O.E.E.J.*, Vol. 53, p. 268, Jan. 1961.

³FOX, W. H., ASHWELL, J. K., and WEAVER, A. L. Subscribers' 50-Point Linefinder System. *P.O.E.E.J.*, Vol. 51, p. 81, July 1958.

⁴PENDLEBURY, N. H. A Pulsing and Ringing Machine for U.A.X.s. *P.O.E.E.J.*, Vol. 53, p. 87, July 1960.

⁵SANDER, D. H. A New Power Plant for U.A.X.s No. 12 and 13—Power Plant No. 214. *P.O.E.E.J.*, Vol. 52, p. 265, Jan. 1960.

⁶FRANCIS, H. E. Post-War Exchange Design. I.P.O.E.E. Printed Paper No. 181, 1943.

Book Reviews

“Noise in Electrical Circuits.” F. N. H. Robinson, Fellow of Nuffield College, Oxford, Oxford University Press. 120 pp. 47 ill. 15s.

This little book deals analytically with the types of noise that are inescapable in electronic equipment, that is, Johnson noise, shot noise and flicker noise. The differences between these forms of noise and the conditions under which they are generated are explained, and the magnitudes of the noise powers are related to the characteristics of the generators in which they are produced, whether valves, or resistive and reactive circuit elements.

These results are used to determine the expressions for the basic noise that is unavoidable in various well-known circuits, one chapter being devoted to each class of circuit. The first on linear amplifiers considers audio-frequency and intermediate-frequency amplifiers, cascode amplifiers, cathode followers, distributed amplifiers and the effects of negative feedback on the output-noise content of an amplifier.

This is followed by a short chapter on noise in oscillators, one on mixer noise and one on noise in detectors. In the last part of the book these results are applied to deduce the basic noise that is inescapable in a superheterodyne receiver, and in various sets of transmission equipment and laboratory apparatus in common use.

A useful bibliography is given at the end of the book.

This is a scholarly work, largely mathematical, but quite intelligibly so. It is written from a physicist's viewpoint rather than an engineer's, and the telecommunication-equipment designer may be surprised to find that there are so many inescapable sources of noise in a telephone transmission circuit.

C.F.F.

“Radio and Electronics.” Vol. I and II. Edited by J. H. Reyner, B.Sc. (Hons.), D.I.C., M.I.E.E. Sir Isaac Pitman and Sons, Ltd. Vol. I: ix + 548 pp. 646 ill. Vol. II: ix + 44 pp. 601 ill. £5 5s. per set.

These two imposing volumes contain information on the scale of an encyclopedia. They are fascinating books and as easy to read as the *Post Office Electrical Engineers' Journal*. The editor states that he planned “to provide for the student, the craftsman and even the younger professional engineer, authoritative information on the principal uses of electronic techniques so that he can broaden his outlook and equip himself for promotion.” He should, therefore, interest many readers of this Journal.

The books are collections of lengthy monographs in particular branches of electrical engineering written by contributors who are acknowledged experts. For example in the first volume Professor H. Cotton writes on motors and generators, Dr. J. A. Saxton on microwaves, Mr. E. D. Hart on frequency and pulse modulation, while Mr. J. H. Reyner, the editor, supplies chapters on fundamentals of circuit design and wave propagation. A long chapter on engineering mathematics by Mr. A. Geary is particularly

well presented, but, as all the substance in this chapter is standard material easily accessible already, there seems little point in including it.

The first volume will be valuable to any telecommunication student who can find time to read it, as it contains a great deal of practical background material to support the theoretical work that forms the basis of his electrical engineering degree or diploma of technology.

The second volume consists of 13 essays on radio and allied subjects. Radio transmitters, aerials, and receivers are all described in non-mathematical terms. Then follow chapters on special areas of application, including marine radio, radio in aircraft, radio interference, navigational equipment, principles and applications of radar, and television. A 70-page chapter by Mr. J. Moir on sound-reproducing equipment is a most interesting survey of present-day techniques. Chapters on electro-medicine and on electronics in industry complete Volume Two. The second volume is more readable than the first, and could almost qualify as pleasant armchair reading for telecommunication engineers who wish to get up to date in subjects on the fringe of their own part of the electrical world.

These two volumes are beautifully produced; but at the price they are more suitable for libraries—particularly at engineering colleges—than for private purchasers.

C.F.F.

“Solar Activity and the Ionosphere for Radio Communication Specialists” by M. Ya Bugoslavskaya (translated from the Russian by G. O. Harding). Pergamon Press, Ltd. xi + 39 pp. 12 ill. 12s. 6d.

This little book is an English translation from the Russian of a lecture surveying the results of recent experimental work relating to ionospheric physics and radio propagation done under the Ministry of Communications of the U.S.S.R. The Technical Department of the Ministry of Communications of the U.S.S.R. has been carrying out long-term experimental investigations in the earth's magnetism on the ionosphere and how it affects the propagation of radio waves, and this book gives a survey of this work in a form convenient for the prediction of useful radio-propagation data. The author claims that the lecture contains the fundamental facts about the composition of solar radiation and about the connexion between geomagnetic ionosphere storms and the radiation from active regions of the sun. The lecture is given in two parts: the first deals with the effect of the sun's radiation on the earth's atmosphere and the second with the probable processes in discrete regions of the sun leading to solar flare and the 11-year sun-spot cycle.

The author states that she has tried to answer the questions considered with the most recent knowledge, which is apparently of a similar standard in the U.S.S.R. to that of the U.K. It is of interest that four of the sun-spot photographs reproduced as plates were taken by the Royal Greenwich Observatory and the fifth at the Sacramento Peak Observatory, U.S.A.

C.F.F.

A Multi-Channel Voice-Frequency Telegraph System Using Transistors

R. T. G. SALLIS†

U.D.C. 621.394.441:621.382.3

The frequency-modulated multi-channel voice-frequency telegraph equipment described uses transistors. High performance, obtained by careful attention to design details, enables the equipment to be used to provide telegraph circuits on long inter-continental routes where high modulation rates allow economies in bearer-circuit bandwidth to be obtained by the adoption of multiplexing techniques.

INTRODUCTION

A DESCRIPTION of a frequency-modulated voice-frequency telegraph system employing electronic valve techniques was given in a previous issue of this Journal.¹ Since that time a version using transistors has been developed and is in use by the British Post Office.

DESCRIPTION

The equipment is built using the 56-type equipment practice. One 9 ft rack-side accommodates 24 circuits together with the necessary common equipment, which includes a power-supply unit with voltage regulation. Space is also allocated on the rack-side for a transmission-level measuring set and a relay test panel, which are provided when necessary. The conventional arrangement of jacks for testing the telegraph channels is provided in the middle of the rack-side. Two full rack-sides are shown in Fig. 1.

The nominal channel mean frequencies are to the C.C.I.T.T.* standard,² being 420 c/s for channel 1 and rising by 120 c/s steps to the highest frequency of 3,180 c/s for channel 24. Two additional frequencies of 300 c/s and 3,300 c/s may also be transmitted as pilot frequencies. The frequency deviation used is ± 30 c/s, the higher of the two characteristic frequencies being transmitted to the line for the start polarity, i.e. positive in the British Post Office convention.

A block schematic diagram of the equipment is shown in Fig. 2. The line frequencies for channels 7-18 are directly derived from the individual oscillators of each channel, but the line frequencies for channels 1-6 and 19-24 are obtained by a process of group-modulation. The group carrier-frequency supplies of 2,280 c/s and 4,560 c/s are obtained by division of a crystal-controlled basic frequency of 9,120 c/s. This process avoids the necessity of providing two separate closely-controlled supplies. The line frequencies for channels 1-6 are obtained by group modulating the outputs of channel panels identical with those of channels of 13-8 by 2,280 c/s and selecting the lower side-frequency of modulation. Similarly the line frequencies for channels 19-24 are obtained by modulating the outputs of channel panels identical with channels 14-9 by 4,560 c/s. On the receive side of the equipment the individual channel frequencies are recovered by a complementary process

of demodulation. Two channels, side by side, are accommodated in $3\frac{1}{2}$ in. of vertical rack-space. Each channel panel comprises all components required for a

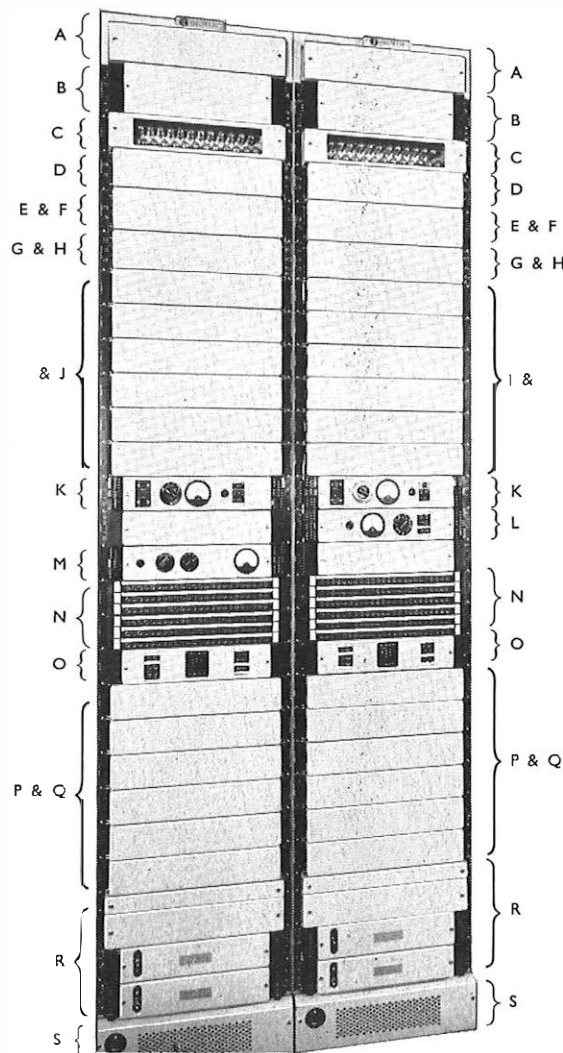

- | | |
|------------------------------------------------------|-----------------------------------------------------------|
| A—Connexion strips. | J—Channels 2, 4, 6, 8, 10 and 12 on R.H.S. of panels. |
| B—Pilot panel. | K—Alarms. |
| C—Resistor bulbs. | L—Relay test. |
| D—Group-demodulator and receive hybrid panels. | M—Level measuring set. |
| E—Receive filter and amplifier. | N—Test jacks. |
| F—Group-carrier oscillator. | O—Test-trunk jacks and test attenuator. |
| G—Transmit amplifier and transformers. | P—Channels 13, 15, 17, 19, 21 and 23 on L.H.S. of panels. |
| H—Group modulators. | Q—Channels 14, 16, 18, 20, 22 and 24 on R.H.S. of panels. |
| I—Channels 1, 3, 5, 7, 9 and 11 on L.H.S. of panels. | R—Power. |
| | S—Power distribution. |

Notes:

- 1 The relay test panel and the level-measuring set are fitted as required for a particular installation.
- 2 The type of power panel fitted depends on whether the equipment is operated from a.c. mains or from d.c. floating-battery supplies.

FIG. 1—LAYOUT OF PANELS ON TWO ADJACENT RACK-SIDES

†Telegraph Branch, E.-in-C.'s Office.

*C.C.I.T.T.—International Telegraph and Telephone Consultative Committee.

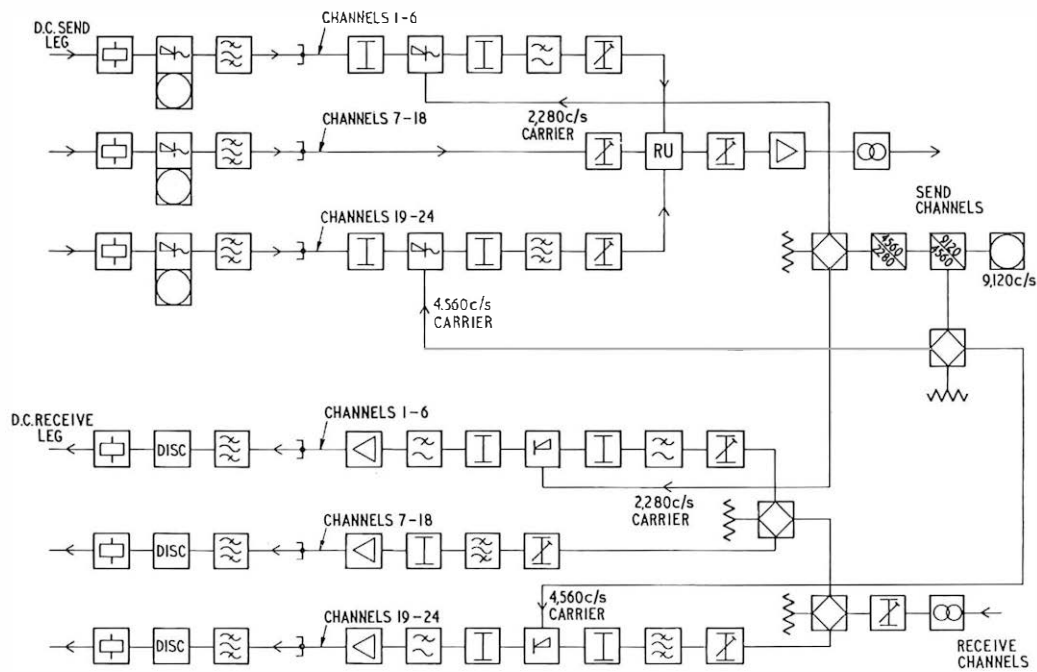

FIG. 2—SCHEMATIC REPRESENTATION OF A 24-CIRCUIT SYSTEM

complete send and receive section with the exception of the protective resistor bulbs, which are mounted together at the top of the rack-side. Fig. 3 shows a typical channel panel front view with the side leaves opened out.

Oscillator-Modulator

A schematic diagram of the oscillator-modulator is shown in Fig. 4. Rectifiers MR5–MR8 are the active elements of a conventional switching network. The

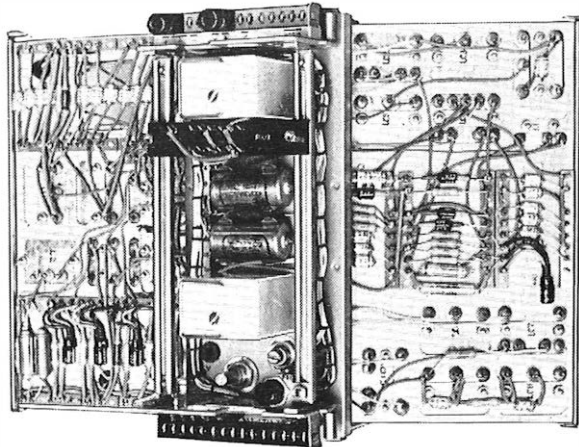

FIG. 3—CHANNEL PANEL WITH SIDE LEAVES OPEN

application of a negative potential, derived from the potential of the send wire, to coil L1 causes rectifiers MR5 and MR6 to conduct and MR7 and MR8 to become high impedance. Capacitor C4 is then isolated from the oscillatory circuit of transistor VT1 and the higher of the two characteristic frequencies is transmitted through the send filter formed by the network LC2–LC5. The frequency under this condition is adjusted by varying capacitor C3, and the output level by resistor R12. The

application of a positive potential to coil L1 causes rectifiers MR7 and MR8 to conduct and MR5 and MR6 to become high impedance. Capacitor C4 is now connected into the oscillatory circuit and the lower of the characteristic frequencies is transmitted through the send filter. Variation of capacitor C4 allows an accurate adjustment of this frequency. The alternative strapping adjacent to capacitor C2 permits the switching network to be reversed to invert the characteristic frequencies if required. This inversion is invoked in those channels whose line frequencies are obtained by a process of group modulation because the selection of the lower sideband of modulation causes an inversion of the characteristic frequencies. The application of a C.C.I.T.T. recommendation³ to British equipment requires that on all channels of a system the lower of the two characteristic frequencies be transmitted to line when a negative potential is applied to the send wire.

There is also a requirement that telegraph modulators be insensitive to currents of less than 4 mA so that they do not operate to line noise when no modulating current is present in the send wire. In these circumstances, the signal sent to line may be that appropriate to a steady stop or start condition, as desired. This facility is provided by the polarized relay RLA. While normal signaling conditions exist on the send wire, the relay is held operated by the line current, which is rectified by the full-wave rectifier formed by rectifiers MR1–MR4 connected in series with the send wire. The contact of the relay, as shown, maintains the send-wire connexion to the modulator. When the line current falls to about 5 mA relay RLA changes over and applies, as required, a full negative or positive polarizing potential via resistor R4 to the modulator.

Detector

A diagram of the detector circuit is shown in Fig. 5. Each channel receive filter is designed to have a mid-

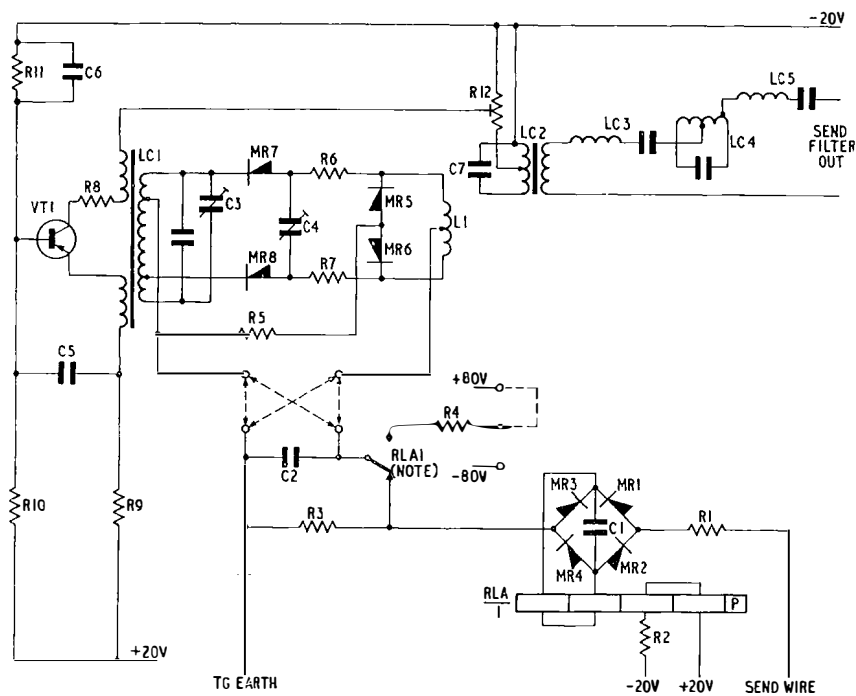

Note: Contact RLA1 is shown operated
 FIG. 4—OSCILLATOR-MODULATOR

band insertion loss of 15 db. The normal input level to the receive filter is -25 dbm. Since it is not possible to make an individual channel level measurement at the

Two series-resonant circuits are connected in parallel across one output of transformer T1. One resonant circuit, LC1 and its associated components, is tuned to the higher characteristic frequency and the other, LC2, etc., is tuned to the lower. The output characteristics of these tuned circuits are shown in Fig. 6. The outputs from these two circuits are individually amplified in transistors VT1 and VT2 and rectified by the full-wave rectifier networks, MR3 and MR4. The two separate outputs are differentially connected and applied through the post-discriminator filter L1, etc., to the load resistor R3. The combined characteristic at this point is shown in Fig. 7. The output relay is controlled by the conventional trigger circuit of transistors VT3 and VT4 which have a common-emitter resistance, R4. Potentiometer RV1 is in this circuit and by its use the operation of the trigger can be adjusted to give a bias-free output from the relay.

When the higher characteristic frequency is being received, the base of transistor VT3 is driven relatively positive, transistor VT3 is cut-off, transistor VT4 conducts, and the output relay RLB operates to the appropriate contact. For

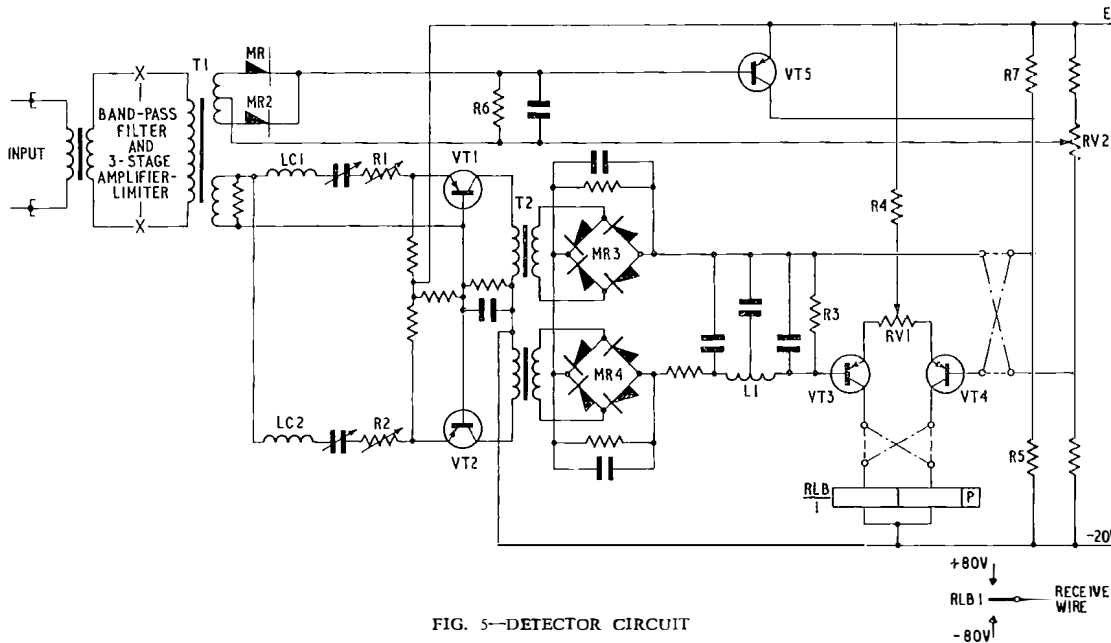

FIG. 5—DETECTOR CIRCUIT

input to the receive filter, this is assessed by a measurement at the output of the receive filter where the normal level is -40 dbm. Successive stages of amplification (not shown in detail) are used as a limiter to enable a signal of constant amplitude to be applied to transformer T1 whenever the input level to the channel band-pass filter exceeds -40 dbm. This represents the lowest input level, as the required operating range is +10 db to -15 db about the nominal design input level of -25 db.

the lower characteristic frequency the base of the transistor VT3 is driven negative, transistor VT3 conducts, transistor VT4 is cut off and relay RLB is operated to the opposite contact. The optional strapping associated with relay RLB decides, for any given channel, which way the relay contact is operated for a given signalling condition. This allows an adjustment on the receive equipment complementary to the inversion sometimes required on the send equipment described earlier. The impedance which transistor VT3 presents to the discrim-

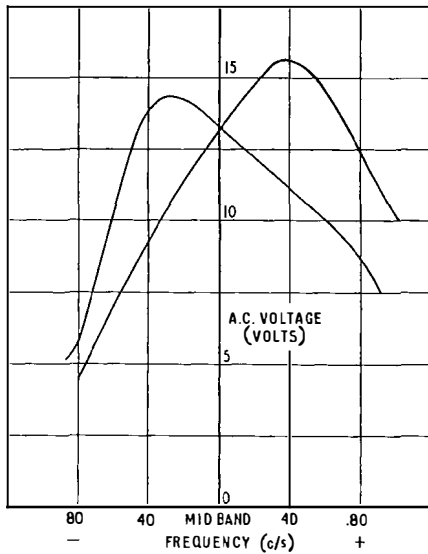

FIG. 6—TYPICAL RESPONSE OF DISCRIMINATOR TUNED CIRCUITS

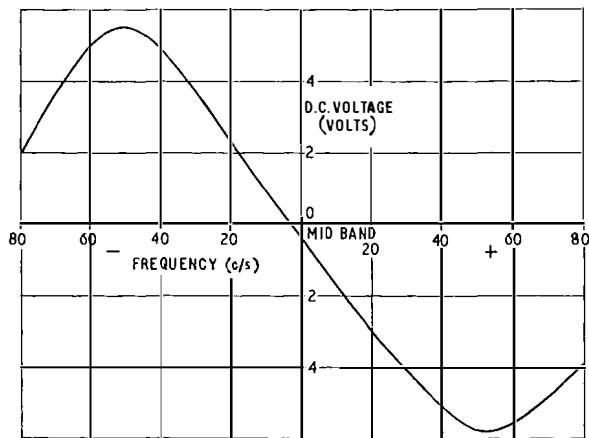

FIG. 7—OUTPUT FROM TYPICAL DISCRIMINATOR

inator output when cut-off, is different from that presented when it conducts so that the operation is not entirely electrically symmetrical. In the original setting-up of the circuit the values of resistors R1 and R2 are adjusted to compensate for this asymmetry.

When the channel input level falls to a value some 6 db below the minimum operating level of -40 dbm, relay RLB has to be operated firmly to either the start or stop contact, as desired, to avoid the relay chattering under line-failure conditions. This facility is provided by transistor VT5 and its associated auxiliary circuit.

The audio signal from a second output of transformer T1 is full-wave rectified by rectifiers MR1 and MR2 to develop a smoothed potential across resistor R6. This voltage is applied in series opposition with the voltage developed across the potentiometer RV2, which is negative with respect to earth, to hold the base of transistor VT5 positive for all input levels in the normal operating range. Transistor VT5 under these conditions is therefore cut-off, and the potential at the junction of resistors R5 and R7 is appropriate to the normal operation of the output trigger circuit of transistors VT3 and VT4. When the incoming level falls to the point that the voltage developed across resistor R6 is less than that across potentiometer RV2, which is adjustable to allow some discrimination in the actual level at which this occurs, the base of transistor VT5 becomes negative, transistor VT5 conducts, more current is drawn through resistor R5 and consequently the junction of resistors R5 and R7 becomes more positive. Coincident with this action, the line-signal voltage applied to the base of transistor VT3 becomes virtually zero. Under these conditions the increased potential at the junction of resistors R5 and R7 will cause either transistor VT3 or VT4 to be cut-off depending on which of the optional strapping associated with the base of transistor VT4 is connected. The output relay RLB is thus operated to the appropriate contact.

Pilot-Frequency Control

On frequency-shift voice-frequency telegraph circuits employing a frequency shift of ± 30 c/s, a bias of 2 or 3 per cent at 50 bauds or 5 per cent at 85 bauds is introduced for each cycle per second that the applied carrier frequency differs from the frequency to which the channel was adjusted. When the telegraph-system bearer circuit is derived from a high-frequency line system, e.g. carrier or coaxial, it is possible to experience variations in the telegraph carrier frequencies and compensation for the subsequent increase in distortion can be provided by the use of a pilot-frequency control panel, which is an optional provision on the equipment. The pilot-frequency control panel, which compensates for errors of up to 16 c/s in the transmission path, is connected in the common receive line.

The basic method employed is to compare the frequency of the distant-terminal 300 c/s pilot tone, transmitted in parallel with the system channel frequencies, with a standard frequency—the local pilot tone. Any disparity between the two frequencies results in an equivalent inverse correction being applied to the aggregate system frequencies. A schematic representation of the arrangement is shown in Fig. 8. Assume that the complex of system frequencies, f_x , and the pilot frequency, f_p , have suffered a change of $+d$ c/s in the

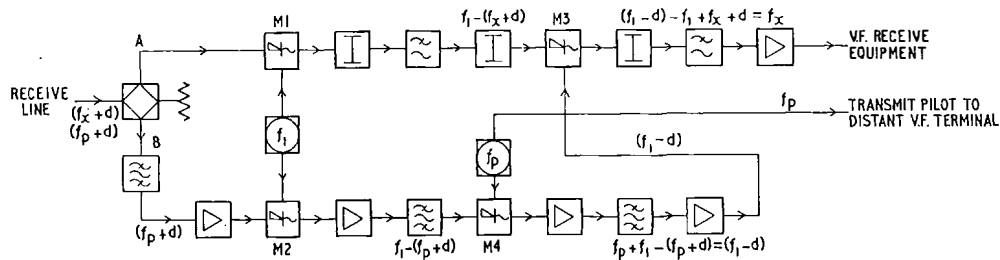

FIG. 8—PILOT CONTROL CIRCUIT

course of transmission. A bandpass filter in path B accepts the incoming pilot frequency.

The signal frequencies in path A and pilot frequency in path B are separately modulated in modulators M1 and M2, respectively, by an intermediate frequency, f_1 . In path B the lower side frequency of this modulation is further modulated in M4 by the local standard frequency, f_p , and the selection of the upper side frequency of this process gives a frequency of $f_1 - d$. This frequency is then used in demodulator M3 to demodulate the lower sideband of the translated signal frequencies in path A, as a result of which the original signal frequencies are applied to the telegraph equipment. The accuracy of this method of compensation depends upon the stability of the pilot-frequency oscillators at each end of a system. There are advantages in using oscillators of the same stability as the normal channel oscillators, and in practice this has been found to be adequate.

A point of design in the modulators used in the pilot-frequency control panel is of importance. The conventional ring modulator requires a high level of carrier input for optimum operation and the resultant carrier leak, even under the best practical conditions of balance, would be too high for this purpose. A ring modulator with transistors as the active elements which allows a very low level of carrier input to be employed, is therefore used. Careful attention in the manufacture of the differential transformers T2 and T3 (Fig. 9) makes the

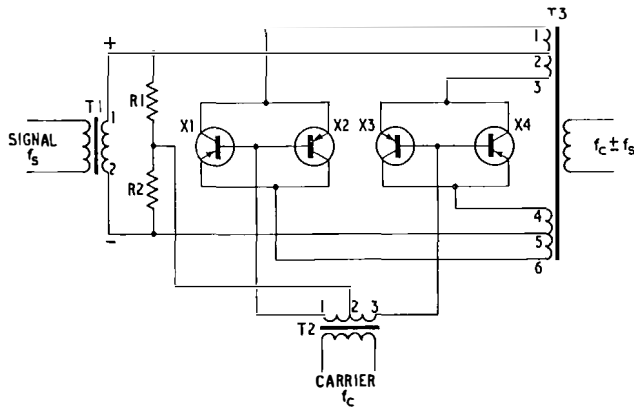

FIG. 9—RING MODULATOR FOR PILOT CONTROL PANEL

device symmetrical to the carrier and input frequencies so that only the sidebands appear at the output. The balance of this modulator is further improved by the use of transistors in pairs. This avoids the use of symmetrical transistors in which the areas of the emitter and the collector at their junctions with the base are the same.

Power Supplies

For optimum operation the equipment requires a smoothed -20 -volt supply regulated to ± 0.3 volts at the input to the panels. If such a supply exists it can be connected directly via the distribution arrangements at the foot of the rack-side. For operation from an a.c. mains supply or unregulated d.c. supply it is necessary to provide suitable conversion equipment, accommodation for which exists on the rack-side. Distribution arrangements for the ± 80 -volt telegraph signalling supply are also provided on the rack-side, but the supply itself has to be brought from an external source.

PERFORMANCE

The design specification requires that the isochronous telegraph distortion of a test signal at 50 bauds shall not exceed 4 per cent over a range $+10$ to -15 db about the normal input level, and that over the same range at 85 bauds the distortion shall not exceed 10 per cent. Experience shows that this performance is easily obtained with wide ranges of ambient temperature.

By the use of sophisticated techniques applied to the output of the post-discriminator filter of the channel panel it has been demonstrated that it is possible to detect and correctly recover a signal transmitted at a modulation rate in excess of 120 bauds. By using such techniques it will be possible to appropriately multiplex three 50-baud telegraph circuits into one telegraph channel of this equipment with a consequent large increase in the information rate. The complexity and cost of the associated equipment would be justified in circumstances where line provision is expensive or line plant is scarce.

CONCLUSIONS

The equipment described above was developed by Standard Telephones and Cables, Ltd., in accordance with the requirements of a Post Office specification. The high performance is obtained by meticulous attention to design and to component tolerances. The equipment may be used to provide telegraph circuits on long intercontinental routes where its good performance at high modulation rates enables economies in bearer-circuit bandwidth to be obtained by the employment of multiplexing techniques. In this way the traffic from two or even three standard 50-baud tributary channels may be simultaneously disposed of over one channel of a system provided by this terminal equipment.

References

- ¹CHITTLEBURGH, W. F. S., GREEN, D., and HEYWOOD, A. W. A Frequency-Modulated Voice-Frequency Telegraph Equipment. *P.O.E.E.J.*, Vol. 50, p. 69, July 1957.
- ²C.C.I.T.T. Red Book Vol. 7 (R35), p. 35.
- ³C.C.I.T.T. Red Book Vol. 7 (R35), p. 34.

A Remanent Relay—Post Office Relay Type 18

U.D.C. 621.318.56

A remanent relay with an inherent magnetic latch has been introduced. It provides the facilities given by a mechanical latching relay but is not subject to the difficulties such as inconsistency of performance and adjustment which, together with their greater weight and size, rule against the mechanical type.

IN circuits where relays are required to remain operated for long periods it may be an advantage if this can be achieved without a continuous current drain. Various methods of mechanical latching have been tried, but difficulties with consistency of performance, adjustment, weight and size have ruled against their use in any quantity.

Remanent relays with an inherent magnetic latch have been in production for some time, and one such relay, manufactured by Associated Electrical Industries, Ltd., has been tested and now introduced by the British Post Office as Relay Type 18. The core of this relay is of 1·1 per cent carbon-steel hardened and tempered to 500–600 HV 20, giving a material of high remanence. The effect of this high remanence is to maintain the relay in the operated position on the removal of the operating current; hence the name “remanent relay.”

To obtain maximum holding power from the remanence of the core, the total reluctance of the magnetic circuit when the relay is operated must be small. In the Type 18 relay this is achieved by making the core a drive fit into its yoke, and by controlling the relative heights of core and knife edge to give zero air-gap between the core face and the armature in its operated position, the armature having no residual screw or stud. The remaining parts are the same as those used on the Type 10 relay,* except that, on lightly-loaded relays with only one spring-set, a bias spring is fitted in the other spring-set position to increase the armature load and ensure satisfactory release of the relay.

For a remanent relay of this type to hold satisfactorily the specified operate current must have been applied for at least 100 ms. Tests indicate that after such energization the relays remain securely operated under conditions of vibration greater than those experienced in any telephone exchange, or on roads carrying heavy traffic.

Having operated the relay, release is effected by the application of a reverse current of sufficient magnitude to reduce the core flux to a value at which the spring-set load restores the armature, but not high enough to result in flux reversal and re-operation of the relay. The

*ROGERS, B. H. E. The Post Office Type 10 Relay. *P.O.E.E.J.*, Vol. 51, p. 14, Apr. 1958.

core material chosen has a coercive force sufficiently low to enable relay release to be effected at an acceptable order of current. Separate operate and release windings are normally provided to simplify the circuit element required to provide the release current.

An alternative system of release is the use of a make contact of the relay in series with the release winding. This disconnects the release current when the armature has moved sufficiently to allow the contacts to open and, therefore, results in a short release pulse of approximately 10–15 ms; for obvious reasons this series contact is known as a “suicide” contact. This method of release requires a higher release current to ensure that the flux is reduced to an acceptable level. However, due to variations in adjustment and performance of individual relays, and in the release-pulse length, satisfactory flux neutralization may not always result and it is possible for an armature to hold if subsequently operated by hand. To prevent this, it is desirable for the release winding to be shunted by a CR element, where C is about 0·5 μ F and R is a suitable value to limit the charging current. This has the effect of extending the release pulse by maintaining the release current after the suicide contact opens, thus ensuring adequate neutralization of the remanent flux.

This alternative method of release is useful where the normal steady release-current level cannot be controlled with sufficient accuracy, or where pulse release is required—when the pulse length must be adequate to cover the longest time to open the suicide contact.

The remanent feature of these relays makes them susceptible to false operation from spurious earths which may be introduced during testing or maintenance of associated equipment. For this reason, windings are normally earth connected and the relay is controlled by the application of an appropriate battery condition.

As already stated, the magnetic circuit is adjusted for minimum air-gap at the pole face; consequently, irrespective of wear, the component parts of recovered relays may not be re-used. Similarly, in the event of any damage resulting in failure the complete relay will be changed and the faulty one scrapped.

Since the outward appearance of the Type 18 relay is very similar to the Type 10 and confusion could easily arise, blue markings are applied to the armature face and to the sides of the yoke of the Type 18 relay to assist identification. In addition, the coil label is clearly marked REMANENT RELAY. The core head is the same shape and diameter as the nickel-iron core on 3,000-type relays, but has no groove cut in the periphery.

A.K.

Primers for Paint Systems

A. D. WALKER, A.R.I.C.†

U.D.C. 667.638.2

The functions and attributes of primers for paint systems are reviewed, and the different types of primer commercially available are described. The mechanisms by which the primers protect the surfaces to which they are applied are also discussed.

INTRODUCTION

IT is generally appreciated that, apart from "touching up," it is unwise to carry out a painting program without using a primer of some sort; but it may not be realized that the days are over when one could select, almost indiscriminately, one of a few well tried "old faithfuls." New materials, new alloys, and advancing knowledge have added a number of new formulations for primers, many of them being specific for a particular purpose.

The function of a primer is to afford a firm, sound foundation on which a protective or decorative system* can be built, and, in addition, it may itself be required to have specific protective properties. It must have adequate adhesion to the surface to which it is applied and afford good "key" or "tooth" for the next coat. It need not have good "build" (the capacity to be applied thickly to vertical surfaces without running or sagging) as dents, cracks and other defects are best treated subsequently with heavy-bodied "fillers" specially formulated for the purpose. High opacity or obscuring power is not always desirable; it is usual to apply an undercoat to perform this duty and, in fact, several very good primers are available which are nearly transparent.

Although there are many different types of primers on the market, they can be considered in definite categories as follows:

(i) Primers designed for wood, varying according to the use to which the wood will be put.

(ii) Primers intended for metals, and conferring a degree of chemical protection against corrosion. Included in this category will be the various "self-etching" primers.

(iii) Thermally-cured primers for synthetic systems. These may overlap with category (ii) by including corrosion-inhibiting chemicals.

(iv) Anti-fouling primers for marine use.

(v) So-called universal primers.

WOOD PRIMERS

Many wood primers are lead based, and a linseed-oil, red-lead and white-lead mixture is still among the best. This affords excellent protection for timber required to withstand exterior weathering and is very durable, but suffers from the disadvantages of a comparatively slow drying time and an inherent softness which results in poor abrasion resistance. If applied too thickly a dry

skin may be formed with liquid paint underneath which may not completely harden for weeks.

The mechanism by which lead-based paints afford such good protection to timber is not fully understood. It has been claimed that the toxicity of lead towards the fungi which attack wood and cause rotting is a contributory factor. Available evidence suggests, however, that fungi are remarkably resistant to lead compounds even in their more soluble forms, and the indication is that the lower the form of life, be it animal or vegetable, the greater is the tolerance to lead. Test panels have been prepared, using paint containing a high proportion of lead compounds and also using paint containing a similar proportion of zinc compounds. Exposure in the tropics has resulted in heavy growth of fungus on the former, but much less on the latter, yet it cannot, therefore be claimed that zinc-based primers are more suitable for use on timber than those based on lead.

Obviously, other factors must be considered. For instance, both lead and zinc compounds react slowly with linseed oil, producing metallic soaps which modify the properties of the paint film in which they are formed; it seems that whereas the lead soaps so formed yield a paint possessing elasticity and long life, zinc soaps produce brittleness in the film, leading to premature failure. But the picture is by no means clear cut, and other factors may be equally important.

It is important to remember that as lead is a cumulative poison for human beings, paints containing red lead and white lead must not be sprayed or used when there is any risk of ingestion.

Of recent years leafing‡ aluminium primers have become more popular for use on timber. Unless carefully formulated, such paints may not possess the elasticity of white-lead based primers and so have a shorter useful life. On the other hand, they have the advantage of a quicker drying time and can be applied to creosoted or new wood without the prior use of sealers.

Whichever primer is used, great care should be taken to ensure that the wood is as clean and dry as possible before painting and that the primer is worked well into the wood in such a manner that penetration into the wood cells is achieved, leaving only a thin film on the surface.

PRIMERS FOR METALS

With metals, as with wood, for optimum results great care must be taken to ensure that the surface is in a fit state to receive the protective system. Ferrous metals must be free from mill scale and rust, and all surfaces must be free from oil and grease, and, preferably, roughened by sanding, etching or grit blasting.

It is generally accepted that any primer intended for

‡The British Standard definition is as follows: "The particles of certain metallic and other pigments are in the form of thin flakes. When such pigments are mixed with a suitable vehicle and applied as a paint film these thin flakes may float on the surface and slightly overlap each other. This action is known as 'leafing'."

†Test and Inspection Branch, E.-in-C.'s Office.

*The word "system" in this instance means the complete treatment applied to the surface considered as a whole, and might include, for example, a pre-treatment and successive coats of a number of different paints.

use on a metal surface liable to corrosion should confer some degree of chemical or electro-chemical protection. This is particularly important with ferrous metals, as the products of corrosion occupy a greater volume than that of the metal from which they were formed, which leads to lifting of the paint film.

Consider a mild-steel surface protected with a thick bitumen coating, or a paint system based on an aluminium primer. In both cases resistance to moisture penetration may be very good, although some will permeate the film: as long as the protective surface remains unbroken, good protection will be obtained. If, however, the film becomes scratched, chipped or cracked owing to mechanical damage or natural weathering, so that the metal surface is partially exposed, corrosion will commence under the edges of the film surrounding the defect, the film will be lifted in these places, and further corrosion will creep along underneath the film eventually leading to severe corrosion which may be hidden under the paint. The object of chemical or electro-chemical protection is to prevent or inhibit this creepage of corrosion from the site of injury.

Varieties of primers for steel are legion. At one time, those based on modified linseed oil, red lead and white lead were very popular and are still used on a large scale, but, whilst eminently suitable for structural steelwork such as bridges and cast-iron items such as letter boxes and telephone kiosks, would not be so useful on a production line where rapid drying is necessary. For the latter purpose, chromated red-oxide of iron is the most generally used inhibitor. This can be dispersed in either a rapid air-drying or stoving medium as required, and, unlike lead paints, can be sprayed, since it has little or no toxic effect. It may be of passing interest to note that most re-spraying of motor vehicles at the present time is carried out with "half-hour synthetic cellulose," which dries to a high gloss and obviates the need of lengthy polishing. This material may give rise to serious trouble such as blistering and lifting if applied over conventional air-drying or stoving primers, and care should be taken to apply it only over a specially formulated primer, or, alternatively, over an isolating coat; several are marketed by paint manu-

facturers as "isolators." The Motor Transport Branch of the Post Office Engineering Department prefers to use the more conventional slower-drying coach paints for re-spraying.

Apart from the two classes of pigment discussed above, which have corrosion-inhibiting properties for ferrous metals, two others are used extensively: metallic zinc and calcium plumbate. In order to be completely effective the proportion of metallic zinc present in a primer must be extremely high—in the region of 95 per cent. One theory suggests that when the envelope of varnish round the zinc in the dried film is sufficiently thin to permit the flow of an electric current, sacrificial protection is conferred in a similar way to that given by galvanizing; another claims that zinc compounds formed by reaction with water and air also possess some rust-inhibiting properties. Almost certainly more than one factor is involved.

The mechanism by which calcium plumbate inhibits the corrosion of ferrous metals is quite different. Moisture permeating the paint coating will dissolve a very small amount of the material and so acquire a slight degree of alkalinity. This is one of the factors which confer the rust-inhibiting properties. Certainly, iron immersed in slightly alkaline water has remained clean and bright for long periods whereas similar metal immersed in neutral or slightly acid water has corroded rapidly. Calcium plumbate should not be applied to aluminium or high-aluminium alloys because in this case the alkaline environment which results may actually accelerate corrosion. Tests carried out by the London Materials Section of the Post Office Engineering Department have found that natural weathering corrosion of aluminium test panels (on a roof at Studd St., Islington, London) was increased by the presence of a film of calcium-plumbate primer, although the protection afforded to mild-steel test plates proved to be very good. This effect is illustrated in Fig. 1. Fig. 2 shows how a primer based on zinc chromate has much the same protective value as one based on calcium plumbate when used on mild steel, but, for the protection of aluminium, chromate is superior.

Self-etching primers of the type specified in specifica-

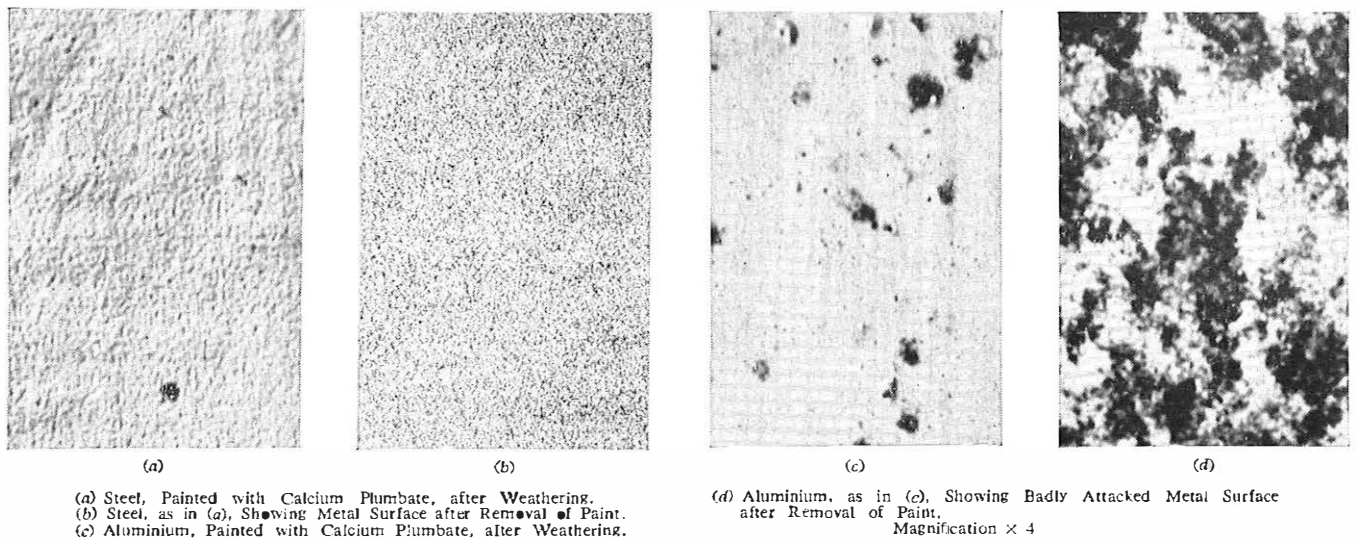
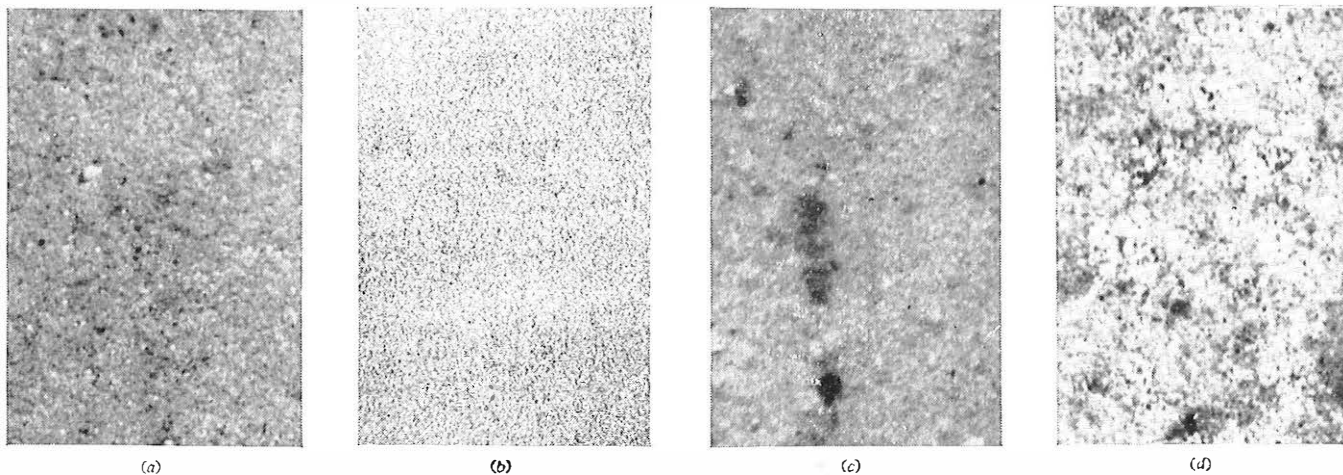

FIG. 1.—COMPARISON OF PROTECTION AFFORDED TO STEEL AND ALUMINIUM BY A CALCIUM-PLUMBATE PRIMER



(a) Steel, Painted with Zinc Chromate, after Weathering.
 (b) Steel, as in (a), Showing Metal Surface after Removal of Paint.
 (c) Aluminium, Painted with Zinc Chromate, after Weathering.
 (d) Aluminium, as in (c) Showing Metal Surface after Removal of Paint.
 Magnification $\times 4$

FIG. 2—COMPARISON OF PROTECTION AFFORDED TO STEEL AND ALUMINIUM BY A ZINC-CHROMATE PRIMER

tion DEF 1408†, should be regarded as a form of pre-treatment that will improve the adhesion of the next applied coat of paint and will also possess some corrosion-inhibiting properties; they are not intended to replace the appropriate primer. They are normally supplied as two separate components, separately packed, to be mixed together immediately before use. Once mixed, the material will retain its properties for up to 8 hours, after which time it must be discarded. As the active ingredient is phosphoric acid the material must be handled with care. Single-pack types are on the market, some of which are of doubtful efficacy. Where possible, hot-dip phosphating is to be preferred, but where facilities for this are not available, or where other considerations render it inadvisable, as when lap-welded joints tend to trap the phosphating solution, etching primers are extremely useful.

One particular important application of self-etching primers is in the painting of freshly galvanized surfaces. These normally require to be weathered for some months before painting, but thorough cleaning to remove traces of galvanizing flux, followed by treatment with etching primer, enables the metal to be painted without the necessity of weathering first. This method has been used for bearers in cable tunnels.

It is well known that pure aluminium requires little or no protection, as it rapidly forms an oxide film which acts as a barrier against corrosion. This "skin" will be firmly adherent under normal conditions, and if fractured will "heal" very rapidly indeed. Aluminium alloys, e.g. the duralumin type, do not possess this fortunate property, as the presence of other elements in the matrix may lead to the setting up of small electric cells in the presence of an electrolyte, with the possibility of severe corrosion. Such alloys are sometimes pro-

ected by cladding with a layer of pure aluminium. Probably the best way of inhibiting corrosion for these alloys is to anodize,§ chromate seal, and apply a chromate-type primer. Should anodizing be impossible, immersion in a mildly alkaline chromate bath under closely controlled conditions, followed by an etching primer specially formulated for use on aluminium, would possibly prove satisfactory.

THERMALLY-CURED PRIMERS

"Baking" or "stoving" primers are much used because of the ease with which they can be fitted into assembly-line production and their inherent stability when fully cured. Most large factories now utilize automatic spraying or dipping equipment, and at automobile works it is not unusual for car chassis or bodies to be completely immersed in a large tank of primer (usually of the chromated red-oxide type), rotated, withdrawn, drained, and passed through a tunnel heated by infra-red radiation or by hot air, which enables curing to be carried out in a few minutes. The primer has obtained a substantial degree of hardness and abrasion resistance by the time the article has reached the spraying position for the next coat, and any light rubbing down necessary may be carried out without delay.

Similar reasons apply to the painting of smaller articles; as space is valuable in most factories, it is not practicable to spread out large numbers of items for several hours to permit air drying.

An advantage to the customer is that longer life is obtained from a well-formulated stoving material than from its air-drying counterpart, other things being equal, because the former has reached (or nearly so) a state of equilibrium by the time it reaches the user and little further change is to be expected. In the case of the latter, however, chemical changes begun during the drying of the paint will continue, albeit at a slower rate, during the life of the film and will ultimately lead, though possibly after some years, to physical breakdown of the protective coating.

PRIMERS FOR MARINE USE

Specially formulated materials should be used to protect against corrosion whenever contact with sea

†Ministry of Defence Specification DEF 1408, Paint Pre-treatment Primer (Etching Primer). Her Majesty's Stationery Office, Feb. 1963.

§Anodize—an electrolytic-oxidation process wherein the metal is made the anode in the circuit and the oxidizing conditions at the anode surface result in the formation of a coherent protective film integral with the base metal. The film is then sealed, for example, by immersion in boiling water. Dyed films can be obtained by immersing the anodized film in a hot dye bath for about 15 minutes before sealing.

water is anticipated. Primers are available incorporating water-resistant media and including compounds made from metals such as copper and mercury that are toxic to the marine growths which might otherwise form on surfaces constantly in contact with sea water.

UNIVERSAL PRIMERS

Primers advertised as being "universal" and suitable for almost all purposes should be avoided whenever corrosion problems are involved. There are on the market "pink primers" resembling white-lead/red-lead in appearance, having a high density (i.e. they feel heavy) yet containing little or no lead, and formulated on cheap ingredients. These may be used in mistake for the genuine article with disappointing results. Others make no pretence of containing lead and are sold under the name "universal primer" or "universal

grey primer." Such materials might serve for use on interior hardboard or similar applications, but very few of these would confer any chemical protection to wood or metal.

CONCLUSION

The list of primers considered is not claimed to be comprehensive, and it must be realized that there are many specially formulated materials for specific purposes: electrically conducting "welding primers," primers for use under cellulose enamels, and those designed for application under moist conditions, are a few of these.

Finally, the fact must be underlined that even the use of the very best primers available may not avoid the disastrous consequences of careless preparation or inadequate pre-treatment of the surface to be painted.

Book Reviews

"Progress in Semiconductors—Vol. 7." Edited by A. F. Gibson, B.Sc., Ph.D., and R. E. Burgess, B.Sc., F.R.S.I. Heywood and Co., Ltd. vi + 238 pp. 66 ill. 65s.

This volume, the seventh of an annual review series, contains four papers, all of considerable theoretical interest and two of some practical interest to semiconductor-device specialists. The first paper, on the element bismuth, relates to a semi-metal rather than to a semiconductor. The differences between such materials originate from the overlap in energy, in a semi-metal, of the top of the valence band over the bottom of the conduction band, though in such a way that electrons having energies in the overlap region are not allowed to have similar directions and magnitudes of momenta if they are in the different bands. In a semiconductor there is no overlap in energy, i.e., there is always an energy gap between the conduction and valence bands. In bismuth the overlap is very small, about 30 milli-electron-volts, and because of this the interesting effects appear mainly at very low temperatures, from a few °K downwards. The paper discusses the various effects, magnetic, electrical conductivity, thermal conductivity, optical, and their interactions, including cyclotron and spin resonances, and attempts to interpret them in a consistent theoretical model, though this is shown to be not yet entirely possible.

The second paper, on the semiconducting compound bismuth telluride, is primarily an attempt to establish a fully consistent picture of the lattice and electronic band structure of the material compatible with the experimental data for thermal and electrical conductivity (the practical interest in the material originally arose because of its hoped-for superiority as a thermo-electric energy convertor material), and the optical and magnetic properties. It is clear that the material is more complex than germanium and silicon, and that further improvements in its preparation will be needed before the necessary further experimental data can be obtained to enable a satisfactory theoretical picture to be built up.

The third and fourth papers are of closer interest to semiconductor-device specialists. The third is on the interaction of impurities with dislocations in silicon and germanium, and, besides introducing some new points in the theory of such interactions, reviews the now extensive data available, in particular on precipitation in silicon containing oxygen with or without aluminium or carbon, and on gold, copper, nickel and lithium effects in silicon and germanium. Several of these effects could be significant in

determining the aging of one or more of the electrical parameters of long-life transistors.

The fourth paper is on the effects of pressure on the properties of germanium and silicon. The experimental techniques are briefly described, and many results are reviewed, but the main purpose of the paper is to attempt to correlate these results with the theory of the electronic band structures of the materials (which are significantly different in this context), and to suggest further crucial experiments. It is probably fair to say that at present, apart from semiconductor strain gauges, these studies are still predominantly of interest for the new light they throw on the physics of the materials rather than on their further early practical applications. F.F.R.

"Radio-Electronic Transmission Fundamentals." B. Whitfield Griffith, Jr. McGraw-Hill Publishing Company, Ltd. xi + 612 pp. 221 ill. 60s.

This is a large well-bound publication of a type that could not have originated anywhere but in the U.S.A. It is, says the author, a "study course for those interested in the generation and handling of high-power radio-frequency energy." He makes it clear that he addresses his book as much to technicians working on radio-frequency heating plant and r.f. chemical and medical applications as to radio-transmitter technicians and radio operators, although these must be more akin to engineers than operators if they are to appreciate this book.

An interesting aspect of this book is the absence of any real mathematics and the lengths and complications to which the author goes to avoid simple algebra and calculus. Where he feels he cannot possibly do without, say, simple integral calculus, he halts his narrative to explain the meaning of integration, as for example when he needs integration to find the inductance of a coaxial cable. It would be quite contrary to British practices to expect anyone unfamiliar with algebra and elementary calculus (say of Ordinary National Certificate Standard) to understand the elements of transmission-line theory or network design. Yet this is what Mr. Griffith expects and has gone to immense trouble to achieve, particularly in relation to aerial feeders. Because this book is based on an approach to technical education so different from ours it is difficult to recommend it to students or technicians seeking to pass British technical examinations. If they look at this book they will, however, realize how much easier electrical-engineering theory becomes for a student with a reasonable foundation in mathematics compared with one who has not.

C.F.F.

Submarine-Cable Earth-Electrode Systems

J. R. WALTERS and G. B. FERNIE†

U.D.C. 621.316.995:621.395.64:621.315.28

The submarine repeaters in submarine coaxial-cable systems are energized by high-voltage d.c. power supplies connected between the centre conductor and suitable earth-electrodes. The factors influencing the design of such earth-electrodes are discussed, and sea earth-electrodes and buried earth-electrodes are described.

INTRODUCTION

It is now common practice to energize the submarine repeaters in submarine coaxial-cable systems from high-voltage constant-current d.c. supplies connected between the centre conductor and suitable earth-electrodes. The ends of the cable may be provided with series-aiding power units as shown in Fig. 1. Alter-

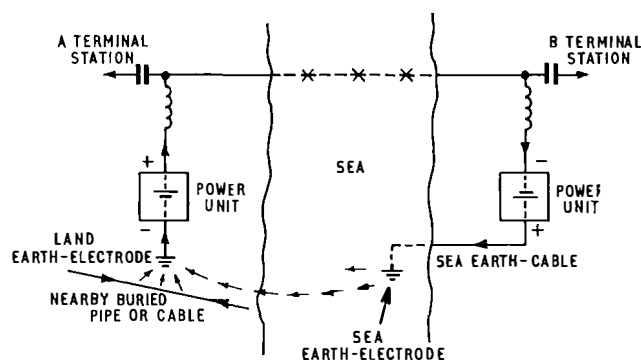

FIG. 1—TYPICAL SUBMARINE-CABLE D.C. POWER-FEEDING ARRANGEMENTS

natively, power may be applied from one end only and a return path provided by earthing the centre conductor at the other end. Permanent direct currents of up to about $\frac{1}{2}$ amp are at present used to energize such systems.

Where the terminal stations are situated near the coast it is usual to provide electrodes in the sea because a low resistance to earth is obtained in salt water, and freedom from disturbance and from lightning damage can probably be assured. If the terminal stations are sited inland it may be more practicable to use earth-electrode systems buried in the soil close to or beneath the terminal stations. Details of a sea-electrode system are described together with brief details of electrode systems used for burying in the soil. The precautions necessary when buried electrodes are provided are also briefly described.

GENERAL CONSIDERATIONS

In submarine-cable practice the terminal stations are known as the A and B stations, respectively. At A stations the earth electrode is connected to the negative pole of the d.c. supply and current flows into this electrode from the surrounding earth or sea. At B stations direct current flows in the reverse direction, that is from the electrode to earth. Electrode systems at both A and B stations are liable to electrochemical corrosion caused by local action, and, in addition, the passage of direct current from electrode to earth or sea at B stations

causes electrolytic action to occur at a rate which is virtually determined by the electrochemical equivalent of the corroding metal and the total quantity of electricity passing to earth. Massive steel plates immersed in the sea were used as electrodes for early submarine-cable systems, and such plates at B stations can be expected to corrode at a rate of about 20 lb per ampere per year. The corrosion is usually localized to particular areas on the electrode and is rarely spread evenly over the whole surface; the connexions between the electrode and the armour wires of the earth conductor are particularly prone to attack.

Consideration must also be given to the siting of earth-electrode systems so that the current passing to or from the electrode does not cause corrosion of the armoring of nearby submarine cables, buried metal pipes or cables. Corrosion attack is most likely to occur on portions of buried structures sited close to buried earth-electrodes at A terminals, because electrolytic current between buried structure and earth-electrode is a maximum at this position (Fig. 1). From experience gained with cathodic-protection schemes there is evidence to show that if current passes to earth from a buried steel pipe and thereby raises the structure-to-soil potential at that point by 10–20 mV then the natural rate of corrosion of the pipe will be substantially increased.¹ This danger may be avoided (or the effect reduced) if the electrode can be sited at least 25 yd from all buried metallic structures, assuming the total current passing to the buried earth electrode is about $\frac{1}{2}$ amp.

The equipment at the terminal stations and the submerged repeaters near the shore ends must also be protected against lightning surges. A power-separating inductor provided in the power-feeding circuit gives some protection against lightning, but it is essential that the earth-electrode should be sited so that its potential is not affected by lightning or static build-up in the vicinity. Sea earth-electrodes are inherently safe from disturbance due to lightning, although the sea earth-cable may be damaged if laid for a long distance in an exposed situation. Buried earth-electrodes in urban areas should also be free from lightning damage because of the protection given by surrounding buildings, but there is a possibility that electrodes buried at shallow depth may be vulnerable to lightning or static if sited on high ground or in isolated situations. However, the danger may be avoided by providing a very deeply driven earth at the terminal station.

SEA EARTH-ELECTRODES

An earth system which makes use of small platinized-titanium earth-electrodes has been designed for use in the sea in place of the large mild-steel plates provided for the older submarine-cable systems. Fig. 2 is a photograph of a sea earth-electrode system with the concrete lid removed to show the electrodes with a connecting cable ready for jointing to the submarine earth-cable.

Each electrode is a cylindrical rod of titanium (9 in. by $\frac{1}{2}$ in. diameter) platinized to a depth of 0.00025 in. for

†External Plant and Protection Branch, E.-in-C.'s Office.

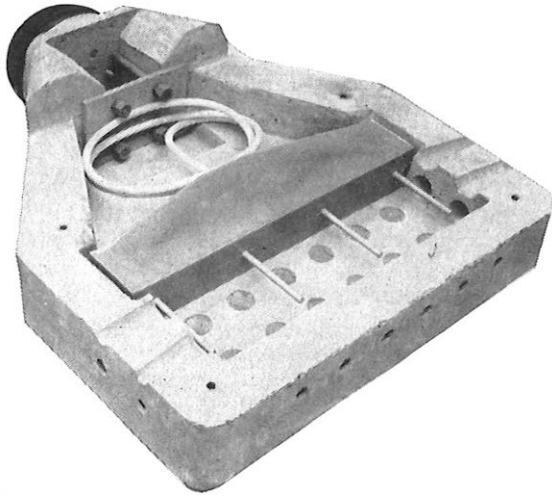

FIG. 2—SEA EARTH-ELECTRODE WITH LID REMOVED

6½ in. of the total length. Four such rods are provided, each having a screwed copper terminal at the unplatinized end. Polythene-insulated submarine earth-cable conductors are brazed to each terminal, and the rods and their connexions are sealed in a large block of epoxy resin so that only 6 in. of the platinized ends of the rods remain exposed. The polythene insulation of the conductors does not bond to the epoxy resin, but during the setting period the resin shrinks tightly on to the polythene-insulated conductors and round the copper terminals. A large block of epoxy resin mixed with marble flour is provided to ensure a long leakage path between the connexions and the surrounding sea-water.

The armour wires of a 4-core polythene-insulated, polythene-sheathed, double-armoured sea earth-cable are securely terminated with wire anchor clamps similar to those used for terminating armour wires at submerged repeaters. Suitable anchor plates for fixing to the concrete housing are provided, and a dome-cover assembly is fitted as shown in Fig. 3. A cavity is provided in the concrete housing to accommodate the connexions to the sea earth-cable. The total weight of the electrode

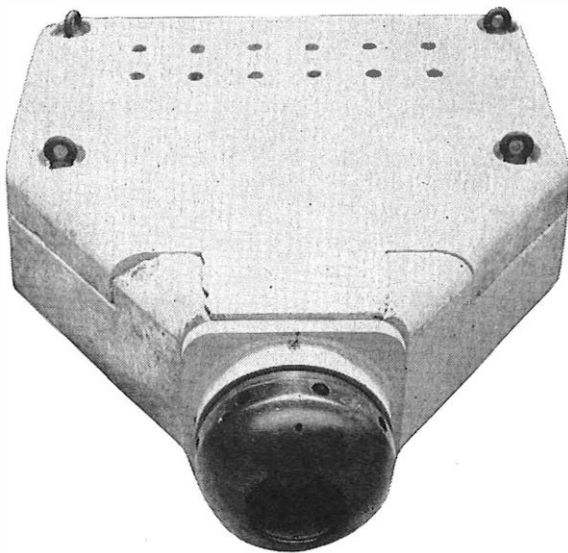

FIG. 3—SEA EARTH-ELECTRODE SHOWING DOME-COVER ASSEMBLY

system, together with its concrete housing and cable-terminating metalwork, is approximately 9½ cwt.

Platinized Titanium as an Electrode

Titanium is used as a core material for the electrodes in order to avoid the prohibitive cost of using solid platinum, and because a protective oxide film forms at points where the sea water comes into contact with the titanium through pores or breaks in the platinum coating. Breakdown of this oxide film will not occur in sea water unless the voltage across the film exceeds about 14 volts, and the use of a platinum coating ensures that the applied external e.m.f. required to pass current is less than the breakdown potential of the oxide film formed on any exposed titanium.

The electrode may be regarded as a platinum electrode supported by a titanium conductor, the exposed portions of which are insulated by a titanium-oxide film, and also as a titanium-titanium-oxide system in which the presence of platinum prevents the potential across the oxide increasing to a value where film breakdown and pitting occur.²

Platinum is a noble metal and is not easily corroded, and, because it ionizes only with difficulty, its ions play little part in the passage of current. Electrolysis is mainly effected by the flow of hydrogen ions and hydroxyl ions formed from dissociated water molecules. The formation of an oxygen film at an anode results in an oxygen electrode, and, at a cathode, a hydrogen electrode is evolved. At an earth electrode a small back e.m.f. therefore builds up which limits the current passed, but the application of an external e.m.f. sufficient to overcome the back e.m.f. causes current to flow and gas depolarization to take place.

Titanium and platinized titanium as anode materials have been described by J. B. Cotton.^{3,4} Anodes with a titanium core and a surface layer of platinum with thicknesses up to 0.0003 in. can be expected to function as plating anodes and as cathodic-protection anodes in sea water for periods of more than one year and up to 15 years, with current densities of between 25 amp/ft² and 100 amp/ft². The platinized rods used for the submarine electrodes described in this article operate at about 2 amp/ft².

The resistance of the oxide film formed on titanium in sea water is much lower when current is passed from the sea to the electrode than when the current passes in the reverse direction and, if the surface area and the current passed are carefully controlled, it is possible to maintain a titanium electrode at a cathodic potential which will immunize the metal against corrosion caused by local action, i.e. cathodic protection is applied.

There is a lack of experience with titanium as a cathode and it has, therefore, been decided to use platinized titanium for both anodes and cathodes of submarine-cable sea earth-electrodes so that the electrodes are interchangeable at A-terminal or B-terminal repeater stations. The risk of installing unsuitable unplatinized titanium electrode rods at a B station is thereby avoided.

Constructional Features

The concrete case of the sea earth-electrode is designed to provide:

(a) protection for the platinized surfaces against abrasion or damage on the sea bed,

(b) a termination for the double layer of armour wires on the sea earth-cable,

(c) a firm anchorage for the sea earth-cable,

(d) a convenient method of providing an insulating gap so that little current flows to or from the electrodes via the armour wires, thereby minimizing corrosion of the armour wires.

(e) a suitably-shaped housing approximately 3 ft long 3 ft wide and 1 ft high that will not damage fishing nets and will not easily be disturbed by dragging anchors, and

(f) additional protection against electric shock if the housing is raised out of the water, since contact with the electrodes cannot be made until the lid is unbolted (circuit arrangements at the repeater stations limit the voltage rise on the sea earth-cable to about 100 volts).

Conical holes are provided in the concrete housing to give access for the sea-water and to ensure a minimum volume of concrete, consistent with structural strength, between the electrodes and the sea. The holes restrict the ingress of large stones and marine vegetation to the interior of the housing without seriously weakening the concrete lid or base. The use of fine mesh over the holes to prevent the entry of small stones, sand or coral was not thought desirable because the complete blockage of the mesh in the course of time would hinder the flow of oxygen or hydrogen from the electrodes. Reinforced concrete made with a sulphate-resistant cement is used to ensure long life and to provide sufficient strength during handling and laying operations.

The polythene-moulded connexions between the electrodes and the sea earth-cable, together with the termination of the armour wires, are usually made aboard ship or on a suitable barge or raft. Four eye-bolts fix the lid to the base (Fig. 3) and provide the means for lowering the housing to the sea-bed. A site well below low-water mark and remote from the main submarine cable, or from other pipes or cables, is necessary.

For the present, three of the rod electrodes are used for the earth system and the fourth is used with suitable monitoring circuits at the terminal repeater station to assess the efficiency of the electrode system at regular intervals. However, consideration is being given to other methods of monitoring the efficiency of the electrodes.

Resistance to Earth

The d.c. resistance to earth of the sea earth-electrode is the apparent resistance of the electrode at a value of direct current equal to that at which the submarine system operates. The resistance is deduced from the e.m.f. applied and the current flowing, after making allowance for the series resistance of the earth conductors. The potentials in the circuit are modified by anodic or cathodic polarization, which varies with the current passed and the time for which the current is applied. The d.c. resistance to earth of the three rod electrodes, calculated from measurements using a.c. methods to avoid the effect of polarization, is approximately 2.0 ohms, making allowance for the resistance of the apertures in the concrete case and assuming a resistivity of 50 ohm cm for sea-water. If the sea-water is diluted with fresh water or if the housing fills with sand or mud, higher resistance values may be expected.

The way in which the resistance to earth of a trial system installed at Lowestoft varies with currents of different values passed to or from the electrodes is shown

in Fig. 4; the direct current was maintained at the various test values for half-hourly periods so that the film of

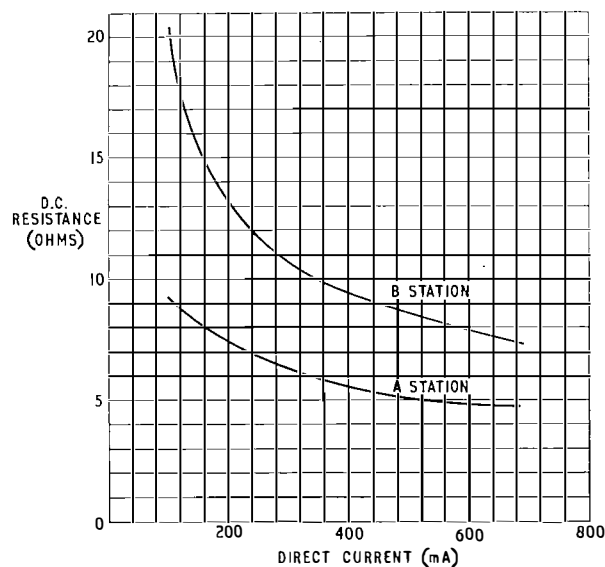

FIG. 4—RELATIONSHIP BETWEEN D.C. RESISTANCE AND APPLIED CURRENT FOR SEA EARTH-ELECTRODE

oxygen or hydrogen, and hence the polarization, could stabilize. The resistance values shown do not include the resistance of the conductors.

The resistance values in Fig. 4 indicate that the electrode system might have a resistance to earth of up to about 20 ohms if the current at which the system operates is reduced to 100 mA. The electrodes may, therefore, not be suitable for some submarine-cable systems equipped with low-current transistor-type repeaters.

The laying trials off Lowestoft were made during bad weather in January 1962 by H.M.T.S. *Iris* in co-operation with a trawler, and, because of rapid change of tide, the electrode system received rough treatment during the laying operation from the deck of the trawler. Subsequent periodic tests have confirmed that the trial was successful, although the weather immediately after laying was too rough to permit the electrode system to be raised for examination.

The unpolarized resistance to earth of the trial electrode system, with the four electrodes connected in parallel, increased in the first month from 1.43 ohms to 3.23 ohms, and this is thought to be wholly due to the system submerging into the sandy sea-bed. Change of resistance with tide is negligible.

BURIED EARTH-ELECTRODES

The experience gained with cathodic-protection ground-beds may be applied to buried earth-electrodes required for submarine-cable systems. The resistance to earth of the electrode will usually be much higher than the resistance of a sea earth-electrode, but the greater resistance will be more than offset by the low series resistance of the earth conductors, since the electrode can be buried within a few feet of, or even beneath, the terminating equipment. A backfill of carbonized coke, coke breeze or similar carboniferous material will help to lower the resistance to earth of the buried metalwork and will also ensure a long life for the electrode, since the carbon provides a conducting path between the metal

core and the surrounding electrolyte (the soil), and electrolytic attack is, therefore, mostly confined to the carbon backfill. There is, of course, an increase in local action due to the galvanic potential set up between the metallic electrode and the surrounding coke, but the net effect is that a steel electrode will corrode at about 3 lb per ampere per year.

Three deep-driven mild-steel earth-spikes, $\frac{5}{8}$ in. in diameter and 20-25 ft deep, were installed at the Middlesbrough B-terminal station of the Anglo-Swedish submarine cable.⁵ The top of each rod is surrounded by a backfill of coke breeze to a depth of at least 5 ft and to a diameter of 18 in. The system has given satisfactory service since 1960, but corrosion of the bottom portions of each spike has occurred, so that the resistance to earth of the system has increased. It is planned to replace the mild-steel spikes with larger silicon-iron rods. The use of eight large anodes made of silicon-iron in a coke backfill is expected to give a long life for the buried earth-system that has been provided for the Widemouth terminal of the TAT-3 submarine-cable system.⁶

Platinized titanium wire and wire mesh surrounded with coke-breeze backfill are being used experimentally for a number of cathodic-protection ground-beds with currents up to about 10 amp. The results of these tests indicate that platinized titanium as a core material buried in coke breeze should provide long service as an earth system for B terminals of submarine-cable systems. It is probable that the ideal system will use a material such as platinized titanium wire driven to depths of up to 100 ft. The difficulty of ensuring a sound buried joint to the electrode can be overcome by extending an un-platinized portion of the titanium wire to a suitable jointing chamber.

The foregoing information refers to buried electrodes at B terminals. The electrode at an A terminal will only suffer superficial corrosion due to local action, and the use of expensive materials or backfills is not necessary. Electrolytic corrosion of nearby buried structures at A-terminal stations may be avoided by connecting the electrode to the station earth-electrode system and to

surrounding metal structures by means of a suitable circuit so that most of the direct current flows into the station earth-electrode. The main function of the electrode will then be to ensure that there is no disconnection in the power-supply circuit and that a dangerous rise of potential does not occur in the event of the station earth system being accidentally disconnected.

CONCLUSION

Platinized-titanium sea earth-electrodes have been put into service at Sydney (Australia), Auckland (New Zealand) and Suva (Fiji) for the COMPAC submarine-cable system,⁷ and at Winterton in Norfolk; land earth-electrodes are being used at Cornerbrook, Newfoundland (CANTAT),⁸ Widemouth (TAT-3), and at Middlesbrough, Douglas (Isle of Man) and Lancaster. Both types are working satisfactorily and further systems are being installed.

ACKNOWLEDGEMENTS

The authors would like to acknowledge the assistance given during the development and installation stages by colleagues in the Submarine Branch and the Main Lines Development and Maintenance Branch of the Post Office Engineering Department.

References

- ¹Co-ordination of the Cathodic Protection of Buried Structures. *P.O.E.E.J.*, Vol. 54, p. 101, July 1961.
- ²SHRIER, L. L. Anodic Polarisation of Lead-Platinum Bielelectrodes in Chloride Solutions. *Corrosion*, Vol. 17, No. 3, Mar. 1961.
- ³COTTON, J. B. Anodic Polarisation of Titanium. *Chemistry and Industry*, Vol. 1, p. 68, Jan. 1958.
- ⁴COTTON, J. B. Further Aspects of Anodic Polarisation of Titanium. *Chemistry and Industry*, Vol. 1, p. 492, Apr. 1958.
- ⁵The Anglo-Swedish Submarine Telephone Cable. *P.O.E.E.J.*, Vol. 53, p. 165, Oct. 1960.
- ⁶A proposed New Cable System Direct to U.S.A.—TAT-3. *P.O.E.E.J.*, Vol. 53, p. 169, Oct. 1960.
- ⁷Inauguration of the Commonwealth Pacific Cable (COMPAC). *P.O.E.E.J.*, Vol. 57, p. 14, Apr. 1964.
- ⁸HALSEY, R. J. The Anglo-Canadian Transatlantic Telephone Cable-System (CANTAT). *P.O.E.E.J.*, Vol. 56, p. 73, July 1963.

Books Received

"Meter Engineering," J. L. Ferns, B.Sc.(Hons.), M.I.E.E., A.M.C.T., A.M.B.I.M., M.I.W.M. Sir Isaac Pitman & Sons Ltd. viii + 392 pp. 195 ill. 42s.

This book is regarded as a standard treatise on this brand of electrical technology. In this seventh edition the text has been thoroughly revised in order to incorporate much new information. The chapter arrangements have been altered to improve the sequence of the subject matter and the text relating to the daily use of meters has been rewritten.

"Dictionary of Electrical Engineering: German-English, English-German." Prof. Dr.-Ing. H. F. Schwenkhagen. Sir Isaac Pitman & Sons, Ltd. 1,058 pp. 85s.

This book is the English edition of the late Professor H. F. Schwenkhagen's dictionary, which was first published in 1959. In the preface to that German edition Professor Schwenkhagen points out that the language of electrical engineering necessarily includes a background of mathematics, physics, chemistry, mechanics, metallurgy, industrial engineering and construction, and this is reflected in his

dictionary, which contains many words and phrases from all branches of engineering.

Included in the dictionary are an excerpt from the Universal Decimal Classification (U.D.C.) system, which for the sake of brevity has the list of numbers cut down to the numbers referred to in the dictionary and uses many abbreviated headings, and lists of common technical abbreviations as used in English and in German.

"Electronics in Industry," J. S. Murphy. Oxford University Press. vii + 216 pp. 119 ill. 25s.

The intention of this book is to outline the many applications of electronics in industry and recent scientific developments in this field.

It explains in relatively simple language the electronic control of machine and process plants, including really heavy manufacturing equipment, machine tools for medium and light engineering production, and the control of chemical plants such as are used in the petroleum and other industries.

Chapter headings include: Synchros and servomechanisms; measuring devices, transducers and actuators; the electronic digital computers, analogue computers; control and automation.

The New Submerged-Repeater Cable System between England and Germany

U.D.C. 621.395.455:621.315.28

A new submarine-telephone-cable system between the United Kingdom and Germany was commissioned in January 1964. The system, of conventional design using a single cable, provides 120 circuits.

A CONFERENCE between the Administrations of the United Kingdom and European countries having North Sea coastlines was held in London in 1961 (the North Sea Cable Conference) at which a program for providing new cables to Europe over the period 1963-67 was agreed.

The first of the schemes ordered as a result of the conference was commissioned in January 1964, and provides 120 circuits between the United Kingdom and Germany. New terminal stations were built at both ends of the submarine-cable system, the British station being sited at Winterton, Norfolk, and the German terminal, which is to form part of a new telecommunications centre and area administration office, was erected at Leer, a small town near Emden. The provision of the entire cable system was put out to international tender, and Standard Telephones & Cables, Ltd. (S.T.C.), were awarded the contract.

The total length of the route is about 254 nautical miles, the North Sea crossing to Borkum Island being about 209 miles in length; of the remaining 45 miles about 15 miles is over the very shallow sandy stretch of water separating the island from the mainland.

The design is conventional, using a single cable; the signals from England to Germany are transmitted in the normal frequency band for supergroups 1 and 2, i.e. 60-552 kc/s, whereas signals from Germany to England are translated by a 1,224 kc/s carrier into the band 672-1,164 kc/s. Signals in both directions of transmission are amplified in a common amplifier in each submerged repeater, the signals in opposite directions of transmission being separated by filters. S.T.C. designed the repeaters to have a gain of 49.7 db at the highest transmitted line frequency, and the spacing between repeaters using armoured 0.62 in. polythene-insulated cable is 12 nautical miles.

It was considered undesirable to site a repeater in the shoal waters between the German mainland and Borkum Island, and the size of cable over this section was therefore increased to 0.935 in. to reduce the attenuation and thus permit a spacing between repeaters of 17 miles. Because much of this shoal cable is likely to be exposed at low tide, it has been necessary to screen the entire length against radio interference. To reduce the risk of damage by shipping and fishing, both to the shoal cable and to the shore-end sea section off Borkum Island, the German Administration have buried the vulnerable sections of the cable in the sand to a depth of about one metre, using their high-pressure water "flush-jetting" method.

The German Administration does not normally employ cable ducts in open country, and hence the 30 miles of screened cable between the landing point at Manslagt and Leer have been armoured and buried in trenches in the ground, not necessarily following roadways. The cable was laid by the German firm, Deutsche Fernkabel-Gesellschaft, but all joints were made by S.T.C. It was necessary to use amplifiers on the long land-section and standard sea repeaters were installed in buried steel chambers in low-ground positions where they would at all times be immersed in surface water.

Although Winterton repeater station has been built close to the sea, the provision of duct-work to the landing point over the sand dunes and through the sand-cliff face presented the Norwich Telephone Area with considerable work of an unusual nature, including a large amount of excavation in wet sand. Due to the shifting nature of this sand it was necessary to arrange for the Army to co-operate and ensure that the route was free of land-mines before work started. With the assistance of the Area staff the shore-end cables for this and two other projects were landed from the Danish cable ship *Peter Faber* during June 1963.

The North Sea off the North German coast was heavily mined during the war, and the British and German Navies undertook the large-scale operation of clearing a passage for the cable during the summer of 1963, prior to the main lay by H.M.T.S. *Monarch* in November. Although the sea cable was laid without any engineering hitches, the operation was delayed by gale-force winds for about 10 days; the engineering representatives of the British and German Post Offices and the S.T.C. personnel were very glad to return to dry land again!

Overall testing was satisfactorily completed during January, and the official opening was performed on 13 February 1964 at a ceremony in London, under the chairmanship of the Postmaster General, where inaugural calls were made to officials of the German Administration in Bonn. There was also a ceremony at Winterton in the presence of Norfolk dignitaries under the chairmanship of the Telephone Manager, Norwich.

A second cable system of the same design is to be laid later this year to cater for the increased traffic expected to result from the introduction of international subscriber dialling to Germany.*

A.P.D. and P.W.L.

*MILES, J. V., and TURNBULL, M. G. Switching Arrangements for International Subscriber Dialling of Calls to Europe (In this issue of the *P.O.E.E.J.*)

A Cordless Telex Switchboard

R. F. HOWARD, B.Sc.(Eng.), A.M.I.E.E.†

U.D.C. 621.394.762.1:621.394.341

A new cordless-type switchboard designed to provide operator control of all telex calls that cannot be completed automatically by the subscribers is described. The design also incorporates facilities for handling the small amount of assistance traffic generated in a fully-automatic telex system. International traffic carried both by radio and cable circuits is handled on the switchboard, and this necessitates some differences in the design of the positions dealing with each type of call. Some novel features of circuits and physical design are described in greater detail.

INTRODUCTION

THE telex service carries a very high proportion of international traffic, and, as countries to which the United Kingdom has telex access progressively make their systems automatic, more and more of the international calls are dialled to completion by subscribers. Nevertheless, there are a number of telex routes which, for technical or traffic reasons, cannot be used for full subscriber-to-subscriber dialling, and the new switchroom of the London (Fleet) telex exchange¹ is arranged to handle the comparatively small amount of telex traffic that cannot be connected completely automatically. The switchroom contains two separate suites, differing in detail, for handling calls routed over radio and cable circuits, respectively; the suite handling cable traffic also deals with the small volume of assistance traffic. The design of the two types of position is such that the differences in operating procedure are slight, and the physical arrangements are very similar.

All calls incoming to the positions are queued in order of arrival; there are two queues, one for the calls routed over radio circuits and the other for calls routed over cable circuits ("radio" and "cable" queues), and they are reached by separate routing codes from the automatic equipment.

† Telegraph Branch, E.-in-C.'s Office.

The two main differences between the classes of traffic are as follows:

(i) The charge for a radio telex call depends on the number of characters actually sent or the number that could be sent as the call progresses, the incidence of poor radio conditions being automatically taken into account by the error-correcting equipment,^{2,3,4} whereas cable telex calls are timed by meters operating every 0.1 min.

(ii) It is a requirement that radio telex calls be continuously monitored, whereas this is not normally necessary for cable telex calls.

The switchboard positions are therefore of two main types designated, respectively, radio and cable positions.

GENERAL DESCRIPTION

Radio Positions

A photograph of a radio telex switchboard position is shown in Fig. 1. Since continuous monitoring is required on radio circuits an operator's teleprinter must be permanently connected to each call in progress. Two teleprinters continuously monitoring radio telex calls are considered a sufficient load for one operator, and, consequently, each radio position has two monitoring teleprinters and two connecting circuits. The connecting circuits are controlled by two keys in the centre of the position and can be connected one at a time to the common position-equipment by appropriate key actions. The common position-equipment is controlled by the keys to the left of the position and by the detached teleprinter keyboard seen in the centre of the position. Call timing is effected by electrically-reset counting meters controlled by an integrating circuit using a uniselector driven by pulses derived from the error-correcting equipment^{2,4} and related to the rate at which characters are transmitted by that equipment.

In front of the operator are five indicating lamps for each of the two connecting circuits and a single lamp associated with the position equipment. By distinguishing between a steady glow or flashing of the connecting circuit lamps, the operator is able to determine the progress of the calls being controlled, and is also able to obtain an indication as to whether the radio circuit to which a call is connected is actually passing traffic or is in the error-correcting condition known as "cycling".^{3,4}

Cable Positions

A photograph of a cable telex switchboard position is shown in Fig. 2. Since continuous monitoring is not required, only one teleprinter is provided on a cable position, and provision has been

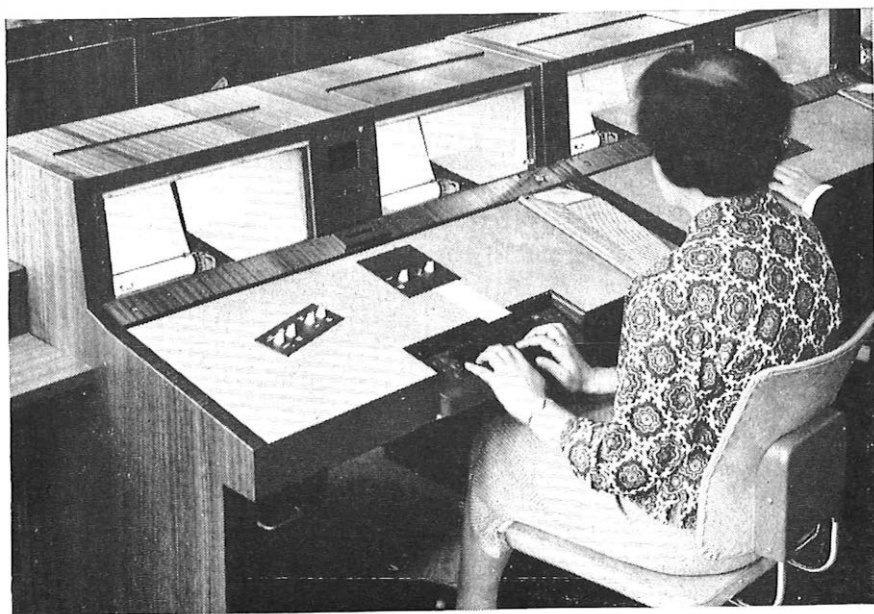

FIG. 1—RADIO POSITION

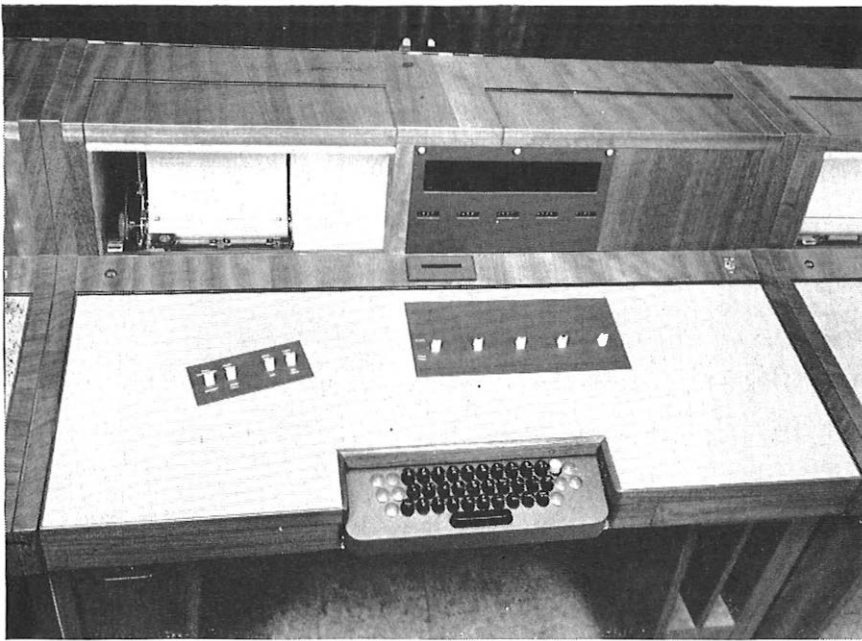

FIG. 2—CABLE POSITION

made for any one of the connecting circuits to be monitored as required, under the control of the operator. One of the keys to the left of the operator connects the teleprinter to the position equipment to permit monitoring to take place.

Five connecting circuits are provided, controlled by keys similar to those on the radio position. Metering is effected by the same kind of counting meter as used on a radio position, but on a cable position the meter is controlled by pulses returned from the cable-circuit relay-sets. The control of the connecting circuits is very similar to that provided on the radio positions.

Outline of Switchboard Operation

A simplified block schematic diagram of the switchboard and its associated equipment is shown in Fig. 3.

All calls are routed to the switchboard queues via selector levels in the Fleet telex exchange, the code dialled determining whether the call arrives in the cable

queue or in the radio queue;⁶ all calls are held in a queue whilst waiting attention from an operator. Calls are extracted from a queue by any operator who is ready to take a call from the queue. A line relay-set, when seized by an incoming call, sets in motion a uniselector that places the call in a queue cell in the queue-control equipment and arranges for a "wait" signal, MOM, to be sent once to the caller. If the caller sends further teleprinter signals, additional MOM signals are returned to him to indicate that he is still connected to the switchboard.

Calls are held in the queue until they are extracted in order of arrival by a queue hunter and connecting-circuit finder, which can only carry out their respective functions when an operator has indicated, by the operation of a key, that the position is ready to accept a call. The operation of this key, the ACCEPT key, lights a lamp in front of the operator

and, if calls are awaiting attention, initiates the extraction processes. When the call has been extracted, the queue-control equipment and connecting-circuit finder are made available for use by other callers, the call is left connected to the position by the line finder equipment and the connecting circuit, and the ACCEPT lamp in front of the operator is extinguished. At this stage the position-identification signal LONDON SWBD P XXX (where XXX is the position number) is sent automatically to the caller as an indication to him to transmit to the operator a request for the number required.

The operator can obtain the caller's answer-back or communicate with the caller, and then connects the position-equipment to the calling side of the connecting circuit to complete the call. All selector functions are controlled by the operator's detached teleprinter-keyboard. The first two numerical characters transmitted are used to select the required route on the forward or

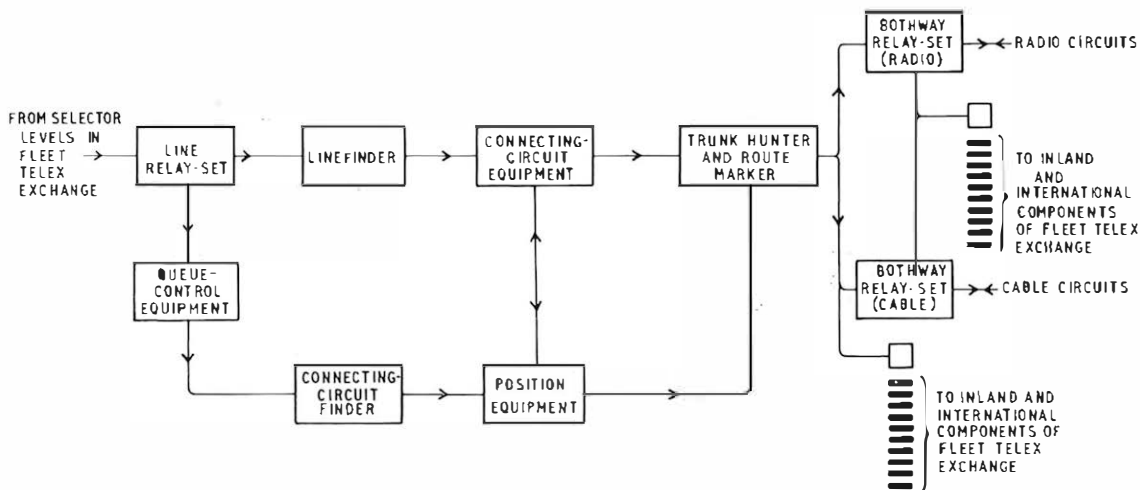

FIG. 3—SIMPLIFIED BLOCK SCHEMATIC DIAGRAM OF SWITCHBOARD AND ASSOCIATED EQUIPMENT

outgoing path. Until route selection has been completed and the outgoing side of the connecting circuit has been associated with the first free circuit of the desired route, further key depressions by the operator are prevented by an electromechanical lock. If no circuits are available the service signal NC is returned to the operator; if the operator selects a routing code that is not in use the service signal NP is returned.

If a circuit is available, the operator keys the remainder of the digits necessary to set up the call. The equipment is conditioned by the routing code to send signals either as dial-pulse or teleprinter signals, as required by the destination of the call.⁶ The return of the call-connect signal from the called subscriber's termination gives an indication on the calling supervisory lamp in front of the operator, who can now exchange the answer-back codes of the two subscribers. The operator disconnects the circuit from the position equipment by operating a key in the position circuit. This action starts the timing counter, and, on the radio positions, monitoring also commences.

A caller can attract the attention of a radio-position operator by sending four carriage-return signals in succession; this causes a lamp to flash in front of the operator. At any time the operator can re-connect one of the connecting circuits to the position equipment and in so doing the timing counter is stopped.

A clearing signal from either the caller or the called subscriber releases all the equipment except the connecting circuit, and at the same time the timing counter is stopped unless the radio circuit is still disposing of the message. After recording the elapsed time the operator resets the meter by operating a key.

The switchboard has been designed primarily for handling calls on demand, but occasionally it is necessary to resort to delay working. A special reverse path (not shown in Fig. 3) is therefore provided from each connecting circuit and is used in the same way as described for the forward path. On all but 10 of the radio positions this reverse path has access to 25 outlets only; the forward path has 200 outlets. The remaining 10 positions have 200 outlets on both forward and reverse paths; these special positions are reserved for handling any delay traffic necessitating such access.

QUEUE CIRCUITS

The two queues, one for the radio suite and one for the cable suite, each cater for a maximum of 200 lines and 200 connecting circuits, a limit set by the use of motor uniselectors. A simplified circuit diagram of the queue circuit is shown in Fig. 4.

Each call intended for a switchboard is routed via the automatic switching equipment in the Fleet telex exchange to a line relay-set in the queue equipment. Each line relay-set is connected to the multiple

of a 200-outlet motor unselector acting as a linefinder and to the wipers of a 25-outlet unselector called the queue hunter. When a line relay-set is seized by an incoming call the operation of relay B starts the associated queue hunter searching for a free queue cell. Each of the 25 queue cells is interconnected with its neighbours as indicated in Fig. 4, so that as one cell is taken into use it automatically makes the next one in the chain available. In this way calls are placed in the cells in order of arrival.

When a call has been parked in a queue cell, arrangements are made to send to the caller a single MOM signal. This signal, like all the printed signals used on the switchboard, is generated in the automatic telex exchange.⁷ The caller can confirm that he is still connected to the switchboard by sending a teleprinter character; this initiates the transmission of a further MOM signal to the caller.

When an operator is ready to accept a call from the queue the ACCEPT key on the position is operated and relay ST in the queue-searcher and connecting-circuit finder relay-set is operated. A contact of this relay starts

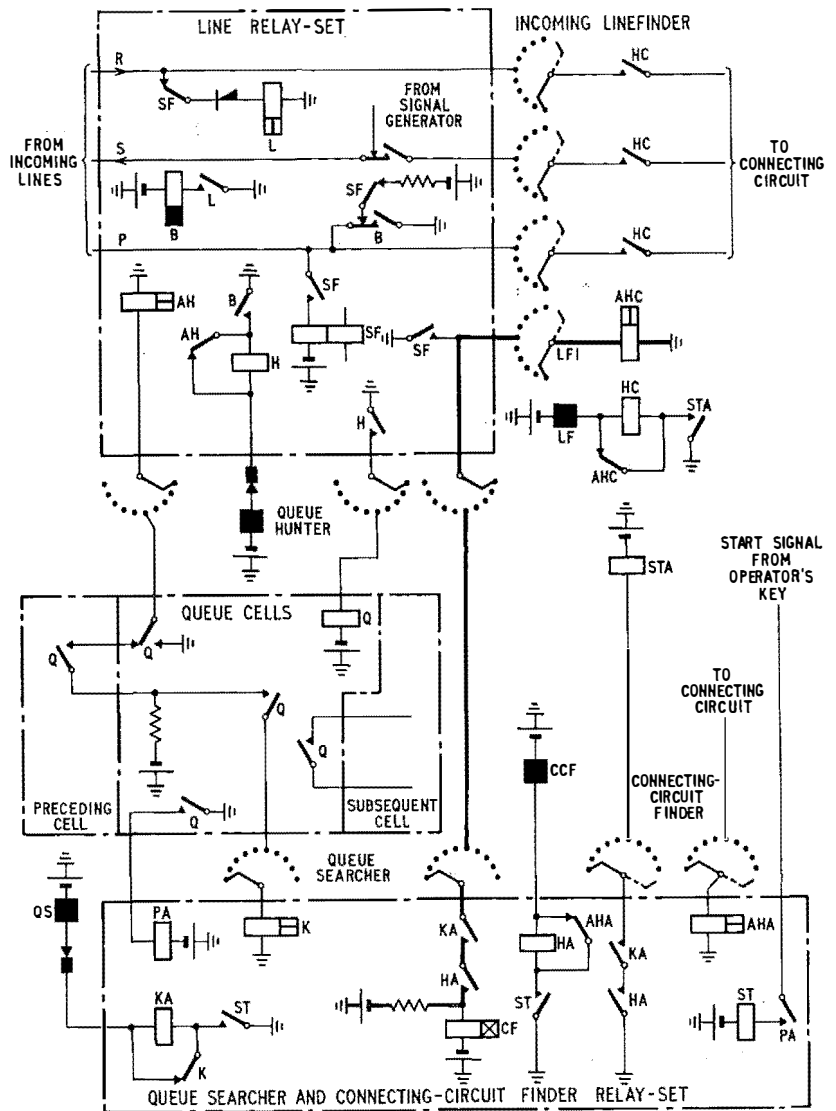

FIG. 4—SIMPLIFIED DIAGRAM OF QUEUE CIRCUIT

the queue-searcher hunting for the next queue cell with a call waiting attention; the queue cell is connected by the contact of relay Q, thereby operating relay K; this stops the hunt and connects the leads through to the relay-set by operating relay KA.

At the same time, the connecting-circuit finder searches for the calling connecting circuit, and, when it has been found, relay AHA operates, stopping the search and operating relay HA, which then operates relay STA in the linefinder circuit. The linefinder hunts for the line concerned, and only one such line can be found as the path shown by the thicker line in the diagram can relate only to the single circuit that is being sought at any one time. Relays HC in the linefinder and CF in the searcher both operate when the right line has been found, and relay CF operates relay SF in the line-relay-set, so allowing the common queue equipment to be released for further calls and the line to be connected directly to the connecting circuit.

the call still fails to be extracted the equipment continues at intervals to try and extract the call.

The length of the queue can be controlled by a switch on the switchroom control console. The number of cells for each position of the switch can be varied by soldered straps, a typical arrangement being two cells for very light traffic loads, five, seven or 14 cells for intermediate traffic loads, and the full 25 for heavy traffic loads. Any call reaching the queue when all cells are occupied receives the "no circuits" signal NC.

POSITION EQUIPMENT

Although the position equipment is divided into separate relay-sets to facilitate apparatus design and mounting arrangements, it forms one large interconnected circuit, the various parts of which are interdependent. A simplified block schematic diagram of the arrangement of the various relay-sets is given in Fig. 5. As described above, the operator's teleprinter is used to

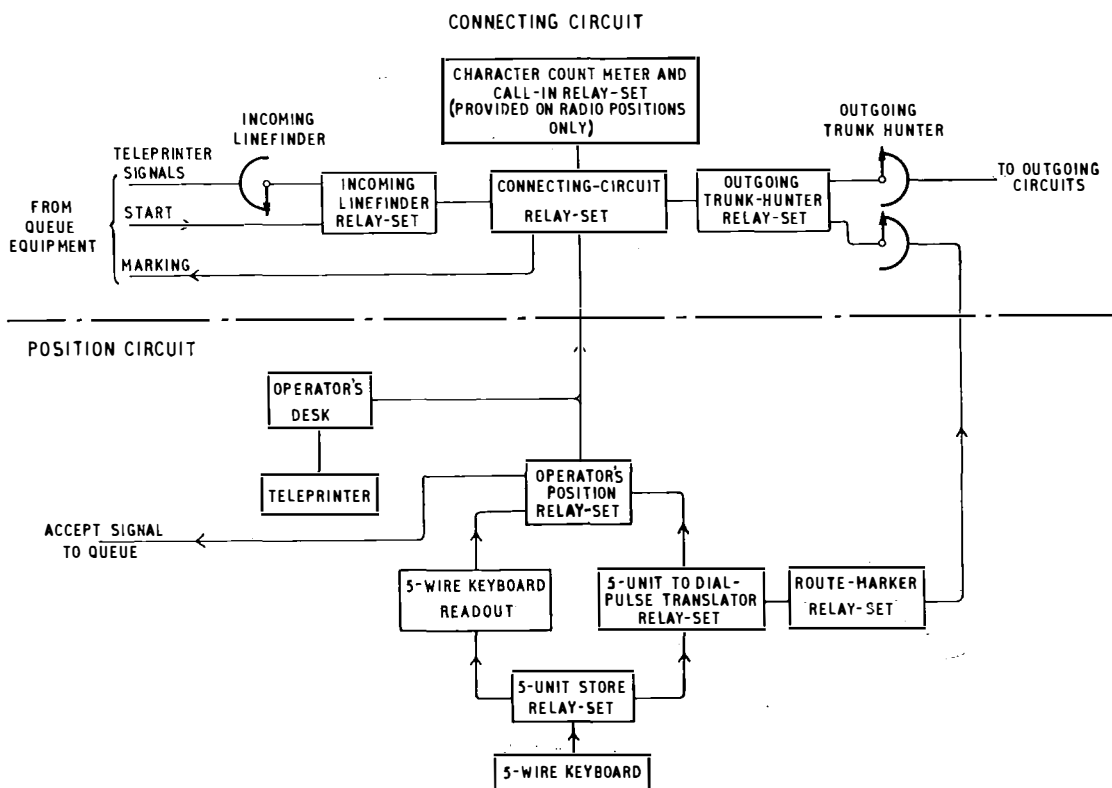

FIG. 5—BLOCK SCHEMATIC DIAGRAM OF POSITION CIRCUIT AND CONNECTING CIRCUIT

It will be noted that throughout the hunting and switching circuit the negative-potential-testing principle has been employed with a high-speed relay-testing circuit-element.

Every call coming into the switchboard must pass through the queue searcher and the connecting-circuit finder in the initial stages of its extraction from the queue. Because of the importance of this part of the circuit both the queue searcher and the connecting-circuit finder are completely duplicated for each queue. The equipment automatically detects a failure to extract a call and changes over the necessary relay-sets to the nominated reserve, at the same time giving an alarm. If

receive the messages both from caller and called party, and, depending on the type of position, is either permanently in circuit or called into use under control of the operator. Immediately in front of the operator is a panel of five lamps for each connecting circuit associated, respectively, with

- (i) the answering side of the connecting circuit,
- (ii) the calling side of the connecting circuit,
- (iii) the through condition when a call is in progress,
- (iv) the cleared condition when either party clears, and
- (v) radio-circuit cycling indication (on cable positions the lamp indicates monitoring).

All teleprinters are arranged to print in black when they

are connected to the caller's (or answer) side of a connecting circuit and in red when connected to the called (or call) side. The colour is controlled by a relay monitoring the transmission direction; the relay operates a small solenoid on the machine. The direction in which the teleprinter is connected is selected by one of the keys shown on the left of the operator in Fig. 1.

Each keyboard is directly connected to the 5-unit store relay-set, which not only stores the signals from the keyboard as they are transmitted but acts as a switching point to direct the signals from the keyboard either via the keyboard readout or via the 5-unit-to-dial-pulse converter. The store is necessary only when the keyboard is connected to the route marker and the translator, since normal sequential telegraph signals are controlled by the readout. The speed of the selection processes in the telex exchange is much slower than the speed at which an operator can key; consequently it is necessary to store the signals whilst selection is completed. The first two digits keyed by an operator when setting up a call are directed by the store relay-set to the route-marker relay-set, and the digits determine the route to be taken by the call. The digits actuate a uniselector circuit and the uniselector applies marking potentials to contacts on the trunk hunter, which then hunts to find the first free circuit in the marked group. Strappings in the route-marker relay-set can be made to indicate to the store relay-set the need, or otherwise, for subsequent routing digits to be sequential telegraph signals. If dial pulses are required for the remaining selection stages the store relay-set remains in circuit until the call-connected signal is returned from the distant termination; the switch in the store relay-set then transfers the keyboard connections to the keyboard readout.

The operator's position relay-set incorporates facilities

simultaneously with both sides of the connecting circuit should this be necessary.

Both linefinders and trunk hunters are motor-driven 200-outlet uniselectors. The maximum number of incoming line circuits and outgoing trunks is thus limited to 200. The trunk hunters give access directly to the cable and radio circuits via bothway relay-sets that enable calls incoming to the United Kingdom to be routed to the automatic telex exchange. A few trunk-hunter outlets are used to give access to the international component of the Fleet automatic telex exchange.

In general the relay-sets use standard electromechanical components, but some electronic components and circuits are employed in two of the relay-sets. One item—the keyboard readout—is described more fully below; the other is the store relay-set, which uses metallized plastic-film capacitors as storage elements, the voltage stored being detected by a transistor amplifier and a relay. This arrangement is an adaptation of a circuit described elsewhere.⁸

Keyboard Readout

The electronic keyboard-readout equipment replaces, with the same degree of timing accuracy, the time-base provided by the governed speed of a teleprinter motor. The physical disposition of the keyboard on the position makes it difficult to provide a mechanical connexion to the keyboard, and, with the arrangement adopted, simple electrical connexions to the keyboard are all that is necessary. For simplicity the keyboard generates a 5-wire signal for each teleprinter character, and the keyboard readout translates these 5-wire signals into sequential teleprinter signals when required. The basic elements of the circuit are shown in Fig. 6. The multi-vibrator is stable and is designed to run at 50 c/s from

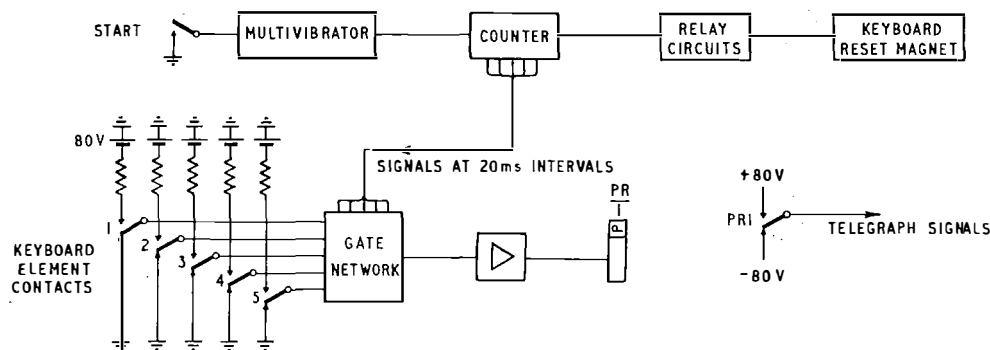

FIG. 6—SIMPLIFIED BLOCK SCHEMATIC DIAGRAM OF KEYBOARD READOUT

for indicating to the queue equipment that an operator is ready to accept a call from the queue. This can only be done when one or more of the connecting circuits on the position is not in use and the operator has actuated the ACCEPT key on the position. Only one connecting circuit can be connected to the position equipment at any one time, the control being by the keys immediately in front of the operator and in line with the lamp displays for the connecting circuits. By means of the connecting-circuit key and one of the position keys the operator can connect the keyboard and teleprinter to either the call or answer side of the connecting circuit, and this is the normal method of operating. However, another of the position keys enables the operator to communicate

a power source that is in turn derived, using a Zener-diode power unit, from the 80-volt signalling battery supplying the associated telex exchange.

The keyboard has five contacts representing the five elements of a teleprinter character, and a sixth start contact that is used to start and stop the multivibrator. The multivibrator feeds 20 ms pulses to a binary counter, the outputs of which are connected to a series of gates. Each gate derives potentials from the five wires associated with the five character-contacts of the keyboard. The presence of a pulse on the wire at the same time as the contact on the keyboard is closed gives coincidence at the gate, so allowing the pulse to pass through and operate a telegraph relay connected to the output via a

transistor amplifier. The elements of the gate circuit are shown in Fig. 7.

At appropriate times in the sequence of operation, signals are extracted from the counter and are made to

The operator's keyboard, detached from the machines, is a special electromechanical development of a current British teleprinter keyboard. The normal comb-bar arrangement used on a motor-driven keyboard is

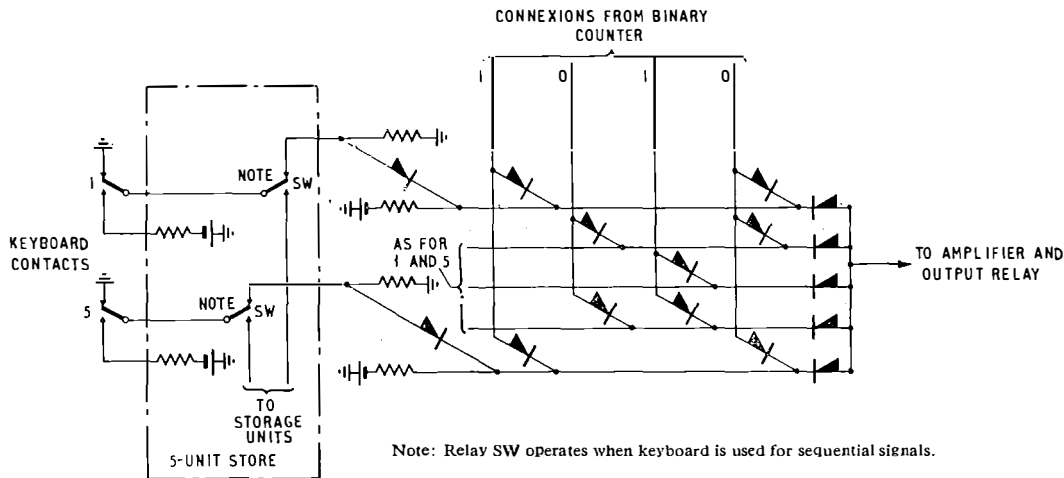

FIG. 7—RECTIFIER GATE CONNEXIONS FOR TWO STAGES OF BINARY COUNTER

operate electromechanical relays that provide start-polarity and stop-polarity signals. Towards the end of a teleprinter signal sequence a further signal is extracted to reset the keyboard ready for the next key depression.

Route Marking

Each connecting circuit of the switchboard has access to a 200-outlet trunk hunter. Since the switchboard must have full flexibility and the growth of traffic is such that the final number of circuits to be connected for any particular route cannot be predicted with great accuracy, the equipment is so arranged that a circuit on any route can be connected to any contact of the trunk-hunter multiple irrespective of when it is connected. The hunter is arranged to select circuits on a route-marking basis. Furthermore, circuits to distant countries can be operated either with dial-pulse selection or directly from the teleprinter keyboard. The route marker is connected by means of simple strap connexions that determine whether the 5-unit-to-dial-pulse converter or the keyboard readout shall be brought into use immediately after the transmission of the route-selection code.

Telegraph Machines

Each radio position has two receive-only teleprinters and each cable position has one; these machines are variants of a current British design. Operating requirements for the two types of position demand that differing arrangements be made for the disposal of the teleprinter copy produced on the positions. On radio positions it is necessary for the operator to tear off the paper and associate each message with a pricing ticket. On the cable positions, however, there is no such requirement for removal of the copy immediately it is prepared, and, consequently, arrangements are made for the paper to be re-rolled within the position by a special drive from the platen of the machine. At the rear of both types of position a special form of paper knife is provided on which the paper can be torn, but apart from the special paper-disposal mechanisms the types of machine used on the cable and radio positions are identical.

retained, but instead of having a single contact operated by a revolving cam and controlled by the comb bars as on the present standard British Post Office teleprinter, each comb bar operates a separate contact when the bar moves after the depression of a character key.

Thus for each depression of a key the appropriate bars produce the International Alphabet No. 2 character in the form of a 5-wire output. The action of depressing any key also releases a sixth bar controlling start contacts that operate before any other contacts. The start contacts initiate the operation of the electrical equipment and at the same time the depression of further keys is prevented until the transmission of the character corresponding to the key already depressed has been completed; this key is held down during the transmission period.

The bars are restored to their normal or rest positions by a magnet—the reset magnet—that is operated at such a time as to complete the restoration of the keyboard approximately 150 ms after the operation of the start contacts as described above.

PHYSICAL DESIGN

In designing the switchboard positions full consideration has been given to comfort and the ability of the operator to reach the necessary controls and to adjust the paper. To facilitate this it has been arranged that a new standard fully-adjustable chair can be used with every position. The design of the switchboards was carried out with the close co-operation of both the Consultant Physiologist to the Post Office and the staff associations. Some of the more interesting points in the design are referred to below.

The positions are constructed of French Cameroon Iroko timber, which has a pleasing appearance, and the sloping desk top is covered with a light-green vinyl plastic that is not cold to the touch. The teleprinters used have stationary carriages; this has meant that a considerable reduction in the width of the machine has been possible compared with the current standard Post Office teleprinter. The reduced width greatly facilitates the provision of internal fluorescent lighting, which gives a

uniform illumination to the paper on each machine, the paper being supported behind a perspex window to display a large page area to the operator, access for paper adjustment being possible from either the front or the back of the position (Fig. 8).

Each machine is mounted on a tray that has locating

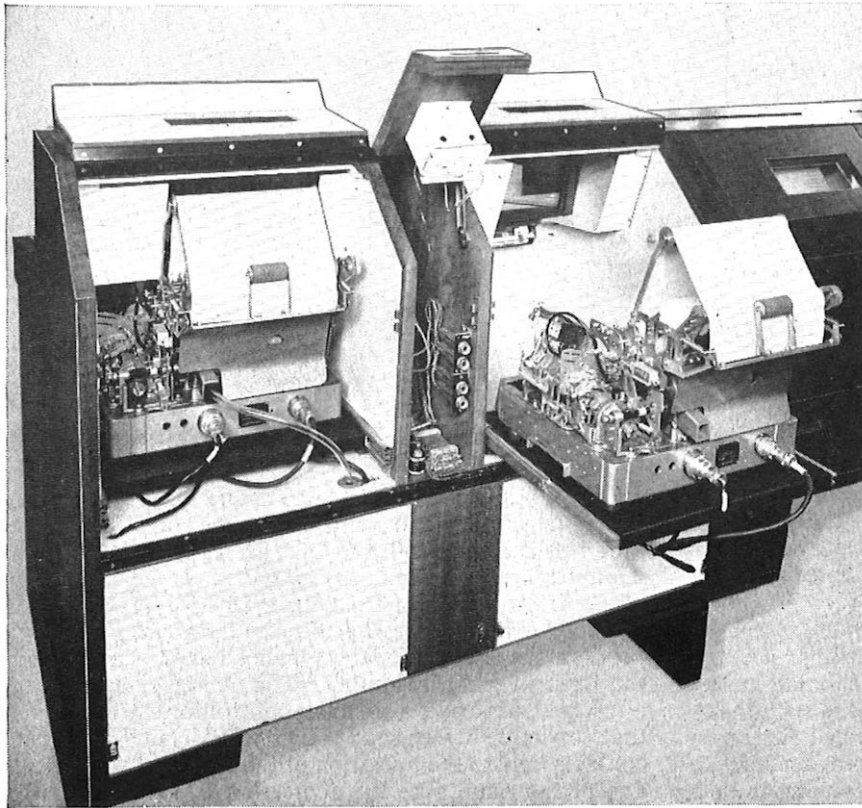

FIG. 8—REAR VIEW OF RADIO POSITION

holes to ensure accurate registration, and each tray can be withdrawn from the rear to make the machine fully accessible for maintenance attention or easy transfer to a trolley, as shown in Fig. 8. Connexion to the machine is made by a socket and plug on the cord and machine, respectively.

All keys used on the positions are non-locking and have twin contacts, and care has been taken to reduce the need for engineering maintenance attention on the positions.

MAINTENANCE

From the foregoing descriptions it will be realized that a single telex call through the switchboard brings into play many different items of equipment. In the past it has been customary to mount on one rack relay-sets all of one type. To facilitate maintenance of the position equipment with its inter-connected relay-sets the racks associated with the cordless switchboard have been designed to accommodate relay-sets of different types. To facilitate the provision of the electronic equipment on normal telephone-exchange type racks, a special form of jack-in strip-mounted relay-set was designed. Five such items (the keyboard readout) together with the Zener-

diode power unit are mounted at the top of a rack that has on it the complete relay equipment for five switchboard positions, the relays being assembled on conventional jack-in plates of appropriate sizes. Thus, maintenance of the equipment on a single position can be confined to attention to one single rack, which also has direct telephone communication with the position to which it is connected.

As a further aid to maintenance each relay-set is provided with a small neon indicator lamp that glows red immediately the relay-set is taken into use; a telltale loop is wired through all relay-sets associated with a position so that the removal of one relay-set prevents the position being used.

When radio propagation conditions are poor, radio circuits can give rise to operating difficulties and it is then necessary to ascertain the number of the particular circuit concerned. With the previous cord-type switchboard an operator knew the number of the circuit to which she was connected, but with a cordless switchboard using trunk-hunting facilities the number of the circuit cannot be made known to the operator unless special provision is made. In this switchboard a special path through the trunk-hunter banks has been provided whereby it is possible for a supervisor, by depressing a key and observing a lamp display on a special radio display console, to ascertain the particular radio circuit connected to a connecting circuit.

ACKNOWLEDGEMENTS

The special teleprinters and keyboards for the cordless switchboard were supplied by Creed & Co., Ltd., who greatly assisted in the special development work involved. The whole installation in Fleet Building, London, was carried out by Ericsson Telephones, Ltd., who also closely co-operated with the Post Office in the development of the switchboard.

References

- ¹ WILCOCK, A., and BAXTER, E. C. Fleet (London) Automatic Telex Exchange. *P.O.E.E.J.*, Vol. 54, p. 53, Apr. 1961.
- ² CROISDALE, A. C. Teleprinting Over Long-Distance Radio Links. *P.O.E.E.J.*, Vol. 51, pp. 88 and 219, July and Oct. 1958.
- ³ CROISDALE, A. C., and HARRISON, A. F. Testing Radio-Telegraph Automatic Error-Correcting Equipment. *P.O.E.E.J.*, Vol. 54, p. 245, Jan. 1962.
- ⁴ CROISDALE, A. C. Improvements in Automatic Error-Correction Equipment Used on H.F. Radio Telegraph Services. *P.O.E.E.J.*, Vol. 55, p. 253, Jan. 1963.
- ⁵ ABBOTT, M. V., and HILL, K. C. J. New Switchboards Speed Overseas Telex Calls. *Post Office Telecommunications Journal*, Vol. 15, p. 11, Autumn 1963.
- ⁶ DANIELS, E. E., and FORSTER, A. E. T. Subscriber Dialling of International Telex Calls. *P.O.E.E.J.*, Vol. 54, p. 103, July 1961.
- ⁷ FORSTER, A. E. T. Automatic Switching for the Telex Service. *P.O.E.E.J.*, Vol. 51, p. 193, Oct. 1958.
- ⁸ SHEPPARD, S. H. Local Register for Director Exchanges. *P.O.E.E.J.*, Vol. 51, p. 301, Jan. 1959.

The Supersession of U.A.X.s 13 by Small Non-Director Exchanges

A. H. HUNT, A.M.I.E.E.†

U.D.C. 621.395.722:621.395.636.7

Where exchanges of the 200-600-line multiple capacity have been required, special unit automatic exchanges have been specified. Now a new type of non-director exchange capable of operating economically in this range has been developed and the first of these is expected to be ready for service towards the end of 1964. The new exchanges are to be known as small automatic exchanges.

INTRODUCTION

THE Unit Automatic Exchange (U.A.X.) 13 was introduced in 1936 and was designed for an ultimate multiple capacity of 200 lines. By 1947 the post-war growth in the demand for telephone service had resulted in several U.A.X.s 13 reaching the limit of their multiple capacity earlier than forecasted. Any further growth could only have been catered for by either installing a larger type of U.A.X. or a non-director exchange, which usually would have required a new site and building. To avoid both the heavy capital expenditure and the delay which this would have entailed, the twin and triple U.A.X.s 13, catering for up to 400-line and 600-line multiples, respectively, were introduced.

Recent changes in policy and practice, including the introduction of group charging, the provision of heating in U.A.X. 13 buildings, and the introduction of subscriber trunk dialling (S.T.D.) and local-call timing, have affected considerably the economic necessity and role of the U.A.X. 13.

The desirability of extending the use of standard non-director equipment to exchanges at present designed as

of providing an equivalent-sized non-director exchange with similar facilities and accommodation as for the U.A.X., and it was shown that in all but the smallest cases the non-director exchange is the cheaper.

Non-director equipment will be used, therefore, for new exchanges which previously would have been designed as U.A.X.s 13. To distinguish this type of non-director installation from others, such exchanges will be known as small automatic exchanges (S.A.X.s).

GENERAL FACILITIES

Numbering Scheme and Trunking Arrangements

A 3-digit numbering scheme is used for subscribers' numbers, the initial digits of which will usually be in the range 3 to 8. These are chosen to suit the direct cabling which will be employed between first and final selectors, and will also facilitate the eventual introduction of 4-digit numbers, when the exchange is later replaced by a larger exchange, by allowing the 3-digit numbers to be prefixed by the digit 2.

Standard S.T.D. facilities will normally be provided for the ordinary subscribers, but will not be given to coin-box lines which will for the time being be provided with pre-payment type coin-boxes.

Alternative trunking schemes are available for S.A.X.s and these differ from one another in the method used for obtaining access to the S.T.D. equipment and to the assistance operator. Referring to the typical trunking diagram shown in Fig. 1 it will be seen that four junction

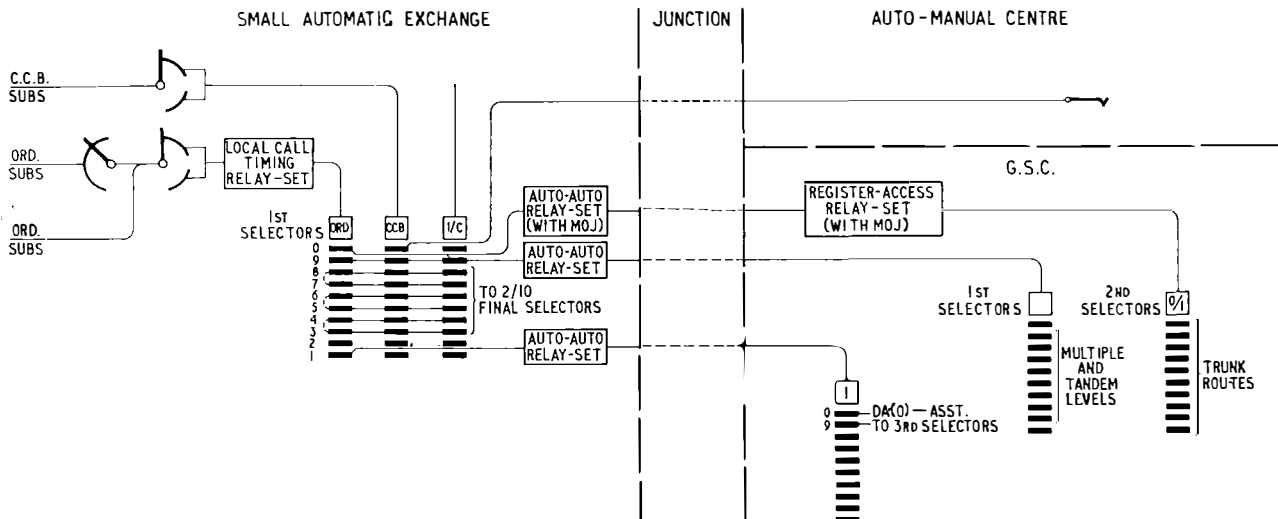

FIG. 1—TRUNKING OF A S.A.X. USING SEPARATE GROUPS OF LEVEL 1, 9 AND 0 JUNCTIONS

U.A.X.s 13 was recognized and this has been the subject of recent examination. The cost of providing a new U.A.X. 13 with S.T.D. facilities was compared with that

†Exchange Equipment and Accommodation Branch, E.-in-C.'s Office.

groups are used for traffic via the group switching centre (G.S.C.). A group of junctions from level 9 at the S.A.X. to 1st selectors at the G.S.C. carries code-dialled traffic to the home and adjacent charging groups. Ordinary subscribers will dial 100 for operator assist-

ance, and this traffic is carried by a group of circuits from level 1 at the S.A.X. to the level-1 2nd selectors at the G.S.C. The pre-payment coin-box subscribers will obtain operator assistance by dialling 0, the calls being routed direct to the manual board over a group of circuits from level 0 of the coin-box group of 1st selectors, S.T.D. traffic from the ordinary subscribers is routed from level 0 of the ordinary-subscriber group of 1st selectors direct to the S.T.D. register equipment at the G.S.C.

The alternative trunking scheme, shown in Fig. 2, requires only a single group of junctions to the G.S.C.

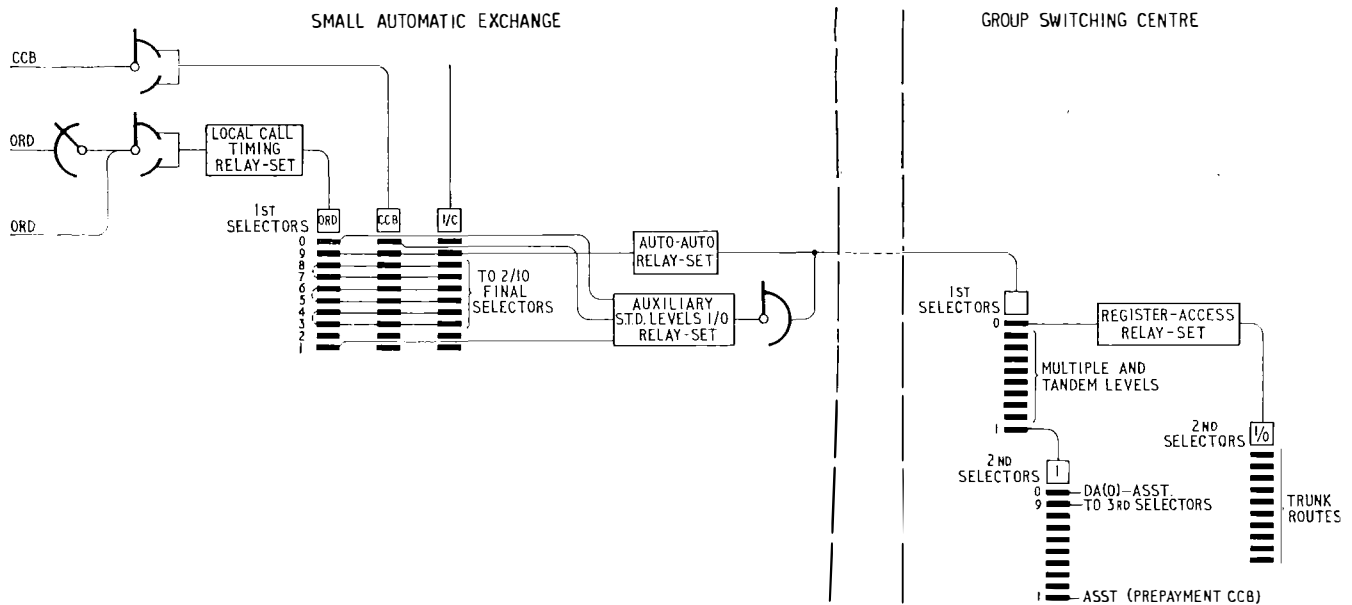

FIG. 2—TRUNKING OF A S.A.X. USING A COMMON GROUP OF LEVEL 1, 9 AND 0 JUNCTIONS

for all classes of traffic and employs new-type equipment similar to that to be installed at U.A.X.s for providing S.T.D. facilities and described in detail in a previous article in this Journal.¹

Tandem Working

The S.A.X. can act as a tandem exchange or auto-switching centre for other small exchanges of the manual, U.A.X. or S.A.X. types. A S.A.X. will not normally be used, however, for routing assistance calls from another automatic exchange to its parent auto-manual switchboard, or as a G.S.C.

Traffic Incoming to the S.A.X.

All incoming junctions and the incoming portions of bothway junctions will be terminated on individual 1st selectors in a separate incoming group. Levels 1 and 0 of this group of selectors are not required for routing traffic since this would permit irregular access being obtained to the assistance operator or to the trunk network.

EQUIPMENT DETAILS

Considerable variation in both type and quantity of the various items of equipment used is possible, and the initial installation and subsequent extensions of a S.A.X. will be provided to meet the individual requirements of the exchange area concerned. This should enable an efficient exchange design to be achieved at all stages in the development of the S.A.X.

General Construction

Standard non-director, open-type, equipment racks 8 ft 6½ in. high are used throughout in the construction of a S.A.X. With this type of construction the provision of heating to control the humidity of the air in the building is necessary. Installation of a S.A.X. follows normal practice, the suites of racks being braced together by overhead ironwork which may also be used for supporting the cable runs.

Existing circuits and types of equipment are used wherever possible for S.A.X.s. In the interest of achieving maximum economies, however, certain new

items of equipment and some minor changes in standards have been introduced.

Combined Main and Intermediate Distribution Frame

A combined main and intermediate distribution frame (M. and I.D.F.) is used and this item is provided in units of 4 verticals. The M.D.F. occupies the lower portion of the frame, and each unit has capacity on the line side for 16 fuse mountings or 640 cable-pair terminations and on the exchange side for 12 test jacks (Jacks, Test, No. 33) or 600 circuits.

The I.D.F. section accommodates 24 connexion strips on either side, sufficient terminating space being available for a 300-line subscribers multiple and the associated calling equipments, junctions and miscellaneous circuits. Thus, a 600-line exchange would require two of these M. and I.D.F. units. Connexion strips suitable for wire-wrapped terminations will normally be used on the I.D.F.

Subscribers' Calling Equipments

Subscribers' 50-point linefinders² and 2-home-position uniselector calling equipments are used together in a S.A.X. The former provide service for all residential exclusive and shared-service connexions, whilst the latter serve coin-box lines and all other categories of exchange connexion not normally connected to linefinders. A S.A.X. will usually only require a single

linefinder rack and this will be equipped as required with the linefinder assemblies, each assembly consisting of two linefinder groups or calling equipment for 98 exclusive connexions. The subscribers' 2-home-position unselector calling equipments have hitherto been available only as completely wired racks, the 8 ft 6½ in. version having capacity for 200 uniselectors. Since a full rack would rarely be justified initially for a S.A.X., arrangements have been made for the uniselectors to be provided in multiples of 50. The normal rack grading facilities will be provided on a partially-equipped subscribers' unselector rack.

Group Selectors

Group-selector racks with grading facilities, and on which both tie circuits to the I.D.F. and direct cabling to final selectors can be provided, are used. Since the use of 20-bank multiples as provided on all existing types of group-selector racks would be wasteful for the small coin-box groups which are likely to be encountered with S.A.X.s., it was decided to introduce a rack having a bank formation consisting of two 10-bank multiples and two 20-bank multiples. With this arrangement the necessary degree of flexibility is provided for producing an efficient exchange design throughout the range of exchange sizes covered by the S.A.X.

A problem arose in connexion with the facility for giving an alternative choice of circuit to a subscriber making repeat-attempt calls during periods when very little or no other traffic is being originated. This facility is provided in non-director exchanges equipped with 2-home-position subscribers' unselector calling equipments by inserting transpositions between the first and second outlets of the selector level concerned, so that outlets 1 and 2 on odd 20-bank multiples are connected to outlets 2 and 1, respectively, on even 20-bank multiples. The alternative first-choice outlets of the unselector grading are allocated to 1st selectors on odd and even 20-bank multiples, respectively. Thus, on a repeat attempt a calling line will be connected to a selector whose first choice outgoing circuit is different from that of the selector seized on the first attempt. The arrangement is shown in Fig. 3(a).

Since a group of calling equipments in a S.A.X. may be served by selectors which are all located in a single bank-multiple group, this method of transposition and selector allocation could not be applied. The transposition of the outlets has therefore been inserted between the fifth and sixth selector banks on each shelf. The alternative first-choice outlets of the unselector grading are then allocated to selectors located in the first and second halves of the shelf, respectively, as shown in Fig. 3(b).

Outlets 1 and 2 of the 200-outlet group selector are located in different bank-contact sets from one another, and, therefore, to facilitate the factory-wiring operations, the transposition is made between outlets 1 and 3, which are adjacent outlets located in the same bank-contact set.

Final Selectors

200-outlet final selectors with 2-10-line P.B.X. facilities are used throughout the range of subscribers' multiple numbers. The standard-type final-selector rack is used, and this can be equipped as required with final-selector units having either 15-bank or 20-bank multiples accord-

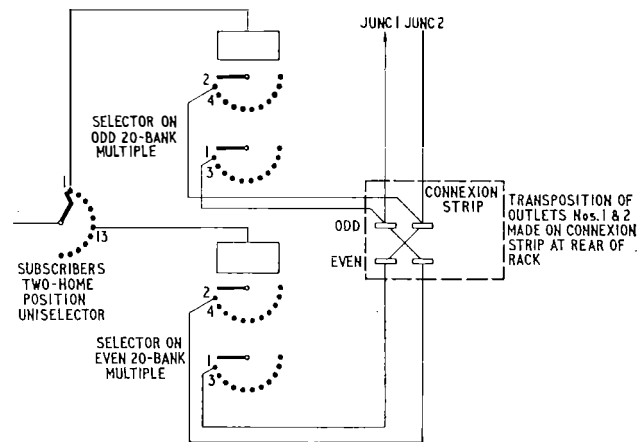

(a) Transposition on Connexion Strip at Rear of Rack.

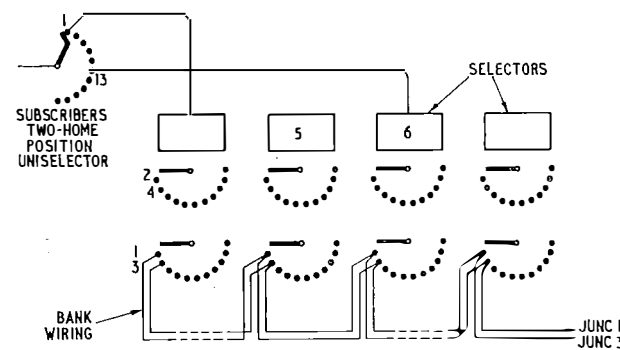

(b) Transposition in Bank Wiring.

FIG. 3—TRANSPOSITION OF OUTLETS GIVING ACCESS TO JUNCTIONS

ing to the traffic requirements. A trunk-offering final selector is provided on each unit.

Subscribers' Meters

One standard meter rack accommodates all subscribers' meters. For reasons of economy at the smaller exchanges with low rates of development, the meters will be provided in units of 100. Thus, a S.A.X. may be equipped for an odd-hundred line multiple although 200-outlet final selectors are standard provision.

Relay-Sets

Where a S.A.X. employs four junction groups to the G.S.C., as shown in Fig. 1, the types of junction relay-sets used will be identical with those employed in a non-director exchange which is remote from its G.S.C. Although no technical restrictions are imposed on the type of signalling which could be used with this scheme, it is very unlikely that any system other than loop-disconnect pulsing would be employed on dialling links.

The alternative arrangement requiring only a single group of junctions to the G.S.C. will usually be the cheaper scheme where junction costs are high. In this instance equipment for signalling systems capable of being employed with junctions over the resistance limit for loop-disconnect pulsing is necessary. Development is at present proceeding for the introduction of loop-disconnect pulsing, Signalling System D.C. No. 2³ (S.S.D.C. No. 2), and Signalling System A.C. No. 8⁴ (S.S.A.C. No. 8) versions of a level-9 auto-auto relay-set, and of a level 1/0 S.T.D. relay-set.

When a single group of junctions to the G.S.C. is used, access to the assistance operator or to the controlling register-translator could be obtained irregularly by dialling the respective codes 9100 or 90. To prevent this, route-barring facilities are being included in the level-9 auto-auto relay-set.

Miscellaneous-Apparatus Rack

As standard provision the miscellaneous-apparatus rack (M.A.R.) will accommodate a power switchboard (Power Switchboard No. 4), a trunk-offering selector, a test selector, a 100-outlet group selector and traffic meters. The test selector is provided solely for use in connexion with the routine testing of subscribers' meters and for this purpose it has joint access with the trunk-offering selector to the trunk-offering final selectors. The function of the 100-outlet group selector is described below. The M.A.R. will also be used to accommodate any other items, such as part-time private-wire switching equipment, as required in individual exchanges.

Alarm-Equipment Rack

In a S.A.X. the ringing and tone supplies are provided from a single machine, no provision being made for change-over to a standby machine as is the normal practice in non-director exchanges. To provide an indication of a machine failure and also of other types of prompt alarms, provision is made for all "urgent" alarms to be extended to the maintenance control centre or parent auto-manual switchboard. Since standard non-director equipment does not incorporate facilities for forcibly releasing calls under permanent line-seizure (P.G.) conditions, S.A.X.s in common with non-director exchanges will be provided with P.G. fault-alarm equipment which can be set to give an "urgent" alarm at any predetermined number of P.G.s. This equipment is located on the alarm-equipment rack (A.E.R.).

The pulse supplies for the local-call timing relay-sets will normally be obtained from a G.S.C. over a carrier system (Carrier System WB400). A special receiver is required for this purpose and is located together with the pulse-distribution equipment on the A.E.R.

SPECIAL FEATURES

Trunk Offering

In non-director exchanges, trunk offering is provided by means of circuits from the auto-manual switchboard to trunk-offering selectors at the automatic exchange, which give access to a trunk-offering final selector in each final-selector group. This method will be used in the S.A.X., but, since a 3-digit numbering scheme is employed and it is desirable to use an existing type of trunk-offering selector, the required multiple number must be prefixed by an arbitrary digit, e.g. 5. Thus, an operator wishing to trunk offer subscribers' number 367, will dial 5367.

Routine Testing of Outgoing Junctions by Operators

Earlier it was mentioned that levels 1 and 0 of the incoming group of selectors could not be used for the routing of traffic because of the possibility of subscribers obtaining irregular access to the assistance operator or to the trunk network. Thus, it is not possible for operators to make routine test calls from

the manual board to a S.A.X. and back to the manual board by dialling over the normal traffic junctions. The arrangement shown in Fig. 4 provides a means of making routine test calls from a S.A.X. by remote-operator control.

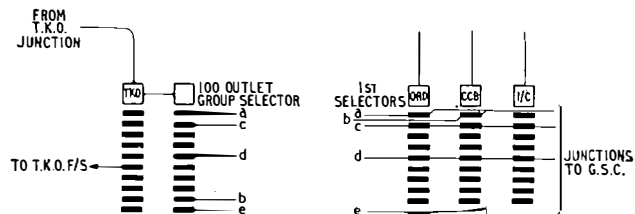

FIG. 4—TRUNK OFFERING AND REMOTE ROUTINE TESTING OF OUTGOING JUNCTIONS

The type of trunk-offering selector used permits a call to be extended via relay contacts in the selector and not via the transmission bridge when certain predetermined digits are dialled. Access is given to a special 100-outlet 2-motion group selector, the vertical and horizontal stepping of the wipers being under the control of the dialled pulse-trains. Selected outlets of this selector are teed to the outlets of the local 1st selectors to which outgoing and bothway junctions are connected. Any junction can be selected and seized by dialling the appropriate digits into the trunk-offering selector and the special 100-outlet selector. Thus, if the digit 8 is required to be dialled into the trunk-offering selector to effect the relay switching, an operator requiring to test junction No. 5 on level 9 would dial the digits 895. Where a common group of junctions serving levels 1, 9, and 0 is employed, access to the group can be obtained via any of the paths of entry. Since the special selector has only 10 outlets per level, if there are more than 10 junctions provided on any level the outlets 11 to 20 of the local 1st selectors will have to be connected to another level of the special selector.

POWER PLANT

For the -50-volt supply a Power Plant No. 214⁵ will normally be used. The system is fully automatic and employs a single battery capable of supplying the load for 24 hours in the event of mains-supply failure.

Positive-battery metering is employed in the S.A.X. A Power Plant No. 221A, which consists of a 24-cell battery trickle charged from a Rectifier No. 87A (a constant-potential type, is provided for this purpose.

EXCHANGE BUILDING

The exchange building is of the Post Office Standard Class II Type B1 or B1 Extended. At present only the timber building is suitable for the S.A.X. and this can be extended, either initially or after erection, in units of standard size. The internal dimensions are:

	Length	Width
B1 Timber	22 ft 5 in.	14 ft 5 in.
B1 Timber Extended	30 ft 0 in.	14 ft 5 in.

The existing brick building is not entirely suitable for the layout adopted for the S.A.X.; a redesigned brick building will probably be introduced in the future.

The initial building is determined by the requirements at the 10-year date: the B1 building will normally be used where the estimated multiple at this date does

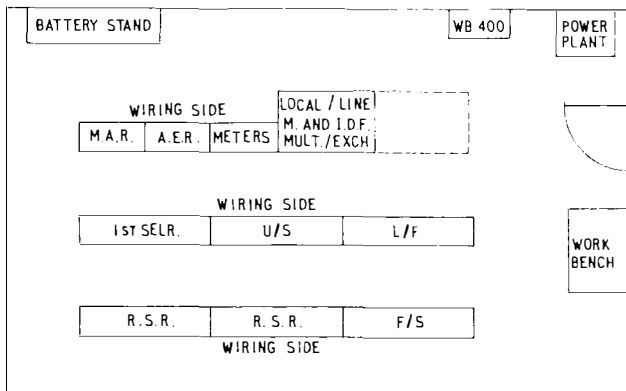

FIG. 5—TYPICAL LAYOUT FOR 400-LINE S.A.X. IN A B1 TIMBER BUILDING

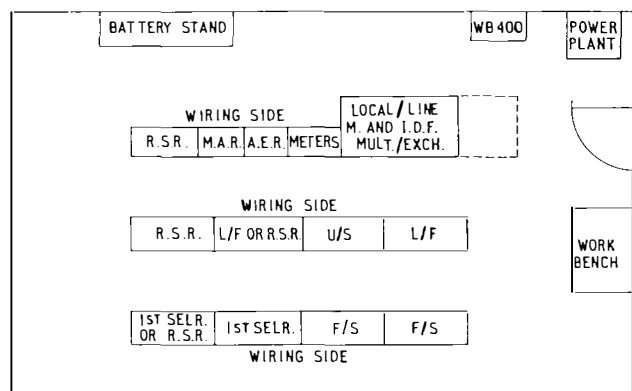

FIG. 6—TYPICAL LAYOUT FOR 600-LINE S.A.X. IN AN EXTENDED B1 TIMBER BUILDING

not exceed 400 lines, and the extended B1 building for exchanges requiring a 600-line multiple.

Figs. 5 and 6 show typical layouts for exchanges having 400-line and 600-line multiples, respectively.

CONCLUSIONS

The extended use of non-director equipment into the field of small exchanges will permit greater flexibility to be achieved in the design of exchanges to meet special requirements, and standard facilities will also be potentially available to a greater number of subscribers.

The first S.A.X. will be installed at Bury in the Brighton Telephone Area, Home Counties Region, and should be ready for service towards the end of 1964.

References

- ¹JACKSON, F. G. Subscriber Trunk Dialling for U.A.X. Subscribers. *P.O.E.E.J.*, Vol. 56, p. 21, Apr. 1963.
- ²FOX, W. H., ASHWELL, J. L. K., and WEAVER, A. L. Subscribers' 50-Point Linefinder System. *P.O.E.E.J.*, Vol. 51, p. 81, July 1958.
- ³WELCH, S., and HORSFIELD, B. R. The Single-Commutation Direct Current Signalling and Impulsing System. *P.O.E.E.J.*, Vol. 44, p. 18, Apr. 1951.
- ⁴HORSFIELD, B. R., and GIBSON, R. W. Signalling Over Carrier Channels that Provide a Built-in Out-of-Speech-Band Signalling Path. *P.O.E.E.J.*, Vol. 50, pp. 76 and 165, July and Oct. 1957.
- ⁵SANDERS, D. H. A New Power Plant for U.A.X.s No. 12 and 13—Power Plant No. 214. *P.O.E.E.J.*, Vol. 52, p. 265, Jan. 1960.

Book Reviews

"Eléments de Commutation Générale. Application aux Systèmes des Téléphonie Automatique." André Blanchard. Eyrolles, Paris. 383 pp. 476 ill. 64.00 N.F.

Although the art of telephone switching has been growing rapidly for fifty years or more and numerous works have been produced describing specialized sections of it, little attempt seems to have been made towards a comprehensive survey. M. Blanchard's book tends to fill this need admirably, although, of course, it could not possibly be a complete guide to such a vast subject. The topics range from the basic principles of binary representation to descriptions of actual circuits, examples generally being taken from the French R6 or Pentaconta system. Various mathematical and diagrammatic equivalents of circuits are described, and a very readable introduction into the manipulation of such forms runs throughout the circuit explanations. The general theory is followed by brief notes on various devices—relays, rectifiers, mechanized selectors, valves, transistors, and ferrite cores—which are then applied as convenient to the basic circuit-elements which form a switching system. The author has chosen to divide the exchange equipment into the following functional sections: counting, coding, code-changing, routing, connecting, marking and selecting. He has given a clear picture of the purpose of each function, together with various practical solutions of the problems faced and their mathematical justification.

Altogether, the book forms a useful introduction to, and summary of, telephone switching principles and methods. Being largely symbolic or diagrammatic, the text is comprehensible even if the reader has little knowledge of French.

H.B.

"Notes for Radio Mechanics in the R.A.F. Part 1—Basic Electricity." Her Majesty's Stationery Office. xi + 197 pp. 283 ill. 15s.

This is a Royal Air Force technical training handbook written as the first of three volumes for the radio-engineering trade group, starting from a most elementary level. It is likely to interest any young electrical technician-in-training who seeks a new approach to electrical fundamentals, because the book is a revelation in showing the advances that have been made in demonstrating abstract ideas to readers previously unacquainted with electricity. This is not a complete textbook but is intended as a companion to supplement demonstrations that are given in class where, presumably, analytical aspects that are missing in the book are also supplied. It explains in chatty language and with light-hearted illustrations the fundamental principles of electricity up to the standard of about Telecommunication Principles Grade A of the City and Guilds of London Institute. Algebra is not used and only the simplest of arithmetic. The author (unnamed) contrives to present everything twice, once in words and again by pictures that often resemble technical comic strips. For example, electromagnetic induction, one of the more difficult concepts to young students, is delightfully explained with many diagrams, including cork screws. The latter half of the book is more seriously written. Vector solutions to very simple a.c. circuits are well explained; the transformer principle and r.f. skin effect in conductors are both clearly described without any mathematics.

No student reading only this book could hope to pass an examination on basic electricity. But he might very well understand the fundamental principles better than many who obtain examination successes simply by learning formula.

C.F.F.

Some Reliability Studies on Silicon Planar Transistors

F. F. ROBERTS, B.Sc.(Eng.),A.M.I.E.E., R. SANVOISIN, B.Sc., A.Inst.P., and
PATRICIA M. MORGAN, B.Sc., D.I.C.†

U.D.C. 620.199:621.382:333

The possible electrical and mechanical failure processes in silicon planar transistors are described together with methods of measuring failure rate in the laboratory. An example is then given of a method of predicting the failure rate of transistors in service using data obtained in the laboratory from randomly-selected transistor samples.

INTRODUCTION

AN analysis reported five years ago,¹ of the results of accelerated aging experiments on germanium-alloy transistors of a construction then popular and still in widespread use, led to the prediction that 50 per cent of such transistors would probably survive continuous operation at a junction temperature of 50°C for some 10 years or more, depending on the operating collector-junction voltage. The experiments showed that, apart from possible catastrophic failures of mechanical origin (which were not investigated thoroughly at that time), the end of useful life of a transistor would be marked by sharp increases in collector leakage current and in the noise figure, though current gain and collector breakdown voltage might vary significantly before the sharp end of life. Since that time large numbers of generally similar transistors have been in service, in audio amplifiers in the telephone system, in hearing aids issued by the National Health Service, and in various low-speed switching applications, under Post Office observation and mostly under operating conditions such that junction temperatures have not greatly exceeded 50°C for more than a small fraction of their operating lives: so far the failures have been so few as to cause negligible operational difficulty in the applications listed.

While the above predictions and field experience may be considered satisfactory for the applications concerned, where each communication channel depends on only a few transistors and where, in the rare event of a transistor failure, the provision of an alternative channel or alternative equipment is a relatively simple and inexpensive matter, the reliability predicted for the popular type of germanium-alloy transistor is quite inadequate to allow consideration of their use in large systems having little or no redundancy—for example, in long multi-channel submerged-repeater systems or in large electronic-switching systems without duplication of the active devices or paths. Thus in any system in which satisfactory operation depends upon the proper functioning of n transistors, the probability p of failure of the system is related to the probability P of failure of a transistor (assumed equal and independent for all transistors) by the expression $P=1-(1-p)^n$. This expression shows that, if a non-redundant 1,000-transistor system is to have a 75 per cent probability of satisfactory operation for a time t , then the transistors should have no more than about 0.03 per cent probability of failure in the time t under the operating conditions in the system. The silicon planar transistor promises to be capable of being produced to meet such

extremely high reliability requirements, even for t values of 20–30 years, for practicable operating conditions in most submerged-repeater and telephone-switching systems.

POSSIBLE FAILURE MECHANISMS IN SILICON PLANAR TRANSISTORS

In the manufacture of a silicon planar transistor,² the connexion of the silicon wafer to the header is usually made by using gold-silicon eutectic alloy as a “solder” at a temperature above its melting point, about 370°C, and this is the lowest temperature for any critical change of state in any part of the transistor structure (compare this with about 150°C for the melting of indium in the germanium-alloy transistor). There is thus a high probability of catastrophic failure if the transistor case is allowed to become hotter than 370°C, and this sets an absolute upper limit to what is permissible in accelerated aging studies. On the other hand, a high bake-out temperature can safely be used prior to the final sealing of the encapsulation and the leak-rate of the encapsulation can be checked to be low, so that the build-up of water-vapour or other possibly undesirable gases can be made negligible during the life of the transistor. In any event the silicon planar structure is much less sensitive than germanium to electrical changes due to absorbed gases or vapours on its surfaces.

There remain two main potential failure mechanisms in well-made planar transistors—other mechanisms may also be present in devices assembled under conditions such that significant numbers of foreign particles above a critical size are sealed in the encapsulation. The first mechanism is the weakening of the bonds between the internal connexion wires, either at the silicon or at the “post” ends, due to the development of a brittle or otherwise mechanically weaker compound between the materials forming the bonds. Thus, when gold connexion wires are bonded on to aluminium-electrode areas on the silicon a series of compounds (“purple plague” and its black and other variants) forms at the bonds and reduces their strength—though the reduced strength may still be adequate if a nail-head bond is used. The rate at which such a compound forms is controlled by the inter-diffusion of the metals on either side. The second main mechanism is less well identified, but is also believed to be controlled in its rate of onset by the diffusion of some “poison” element, either along the surface of the silicon close to the junction edges, or through the oxide layer protecting the silicon surface, or into the bulk silicon from its surface. The first suspect for the poison is gold, which is known to catalyse the recombination of holes and electrons within and, probably, also on the surface of the silicon, and moreover, is also known to diffuse more rapidly than most other suspects into the bulk silicon.

A feature common to most diffusion processes is that the time, t , required for a given concentration of diffusant to build up, at a given distance from the source

†Post Office Research Station.

of the diffusant, is inversely proportional to the diffusion coefficient, D . Because diffusion over the surface or in the bulk of most solids is thermally activated, D is expected to vary approximately exponentially with the negative reciprocal of the absolute temperature T of that part of the solid on or in which the diffusion is occurring: $D = D_0 \exp(-qV/kT)$, where V is the activation energy in electron-volts, q is the electronic charge and k is Boltzmann's constant. Thus, t is expected to be proportional to $D_0^{-1} \exp(qV/kT)$. For the fastest component of the "plague" interaction between gold and aluminium, V is about 1.0 electron-volt and D_0 is so large³ that the brittle compound can consume all the available aluminium-electrode thickness in about 24 hours at 100°C. For the bulk diffusion of gold in silicon, V is about 1.1 electron-volt and D_0 , though much smaller, is believed to be large enough for significant changes in gold concentration to occur at the emitter-base junction and, thereby, to affect the current gain of the transistor in several years of operation at a junction temperature of 100°C—the actual time required will depend on the junction depth from the silicon surface and on the change in current gain tolerable to the transistor user.

METHODS OF MEASURING FAILURE RATES IN THE LABORATORY

Failure rate is defined as the proportion of devices that fail in unit time. A number of usages have grown up for the unit of time, and confusion can arise if a unit is chosen which is short compared with the life of the average device of a given type when the life is controlled by a diffusion mechanism such as outlined in the last section, for then the logarithm of time is physically more significant than time itself. It is now practicable to choose operating conditions such that, with acceptably high confidence, almost all the transistors in a given equipment may be expected to survive for the whole required working life of the equipment. In these circumstances it is reasonable to choose for the unit of time the whole life required for the transistors, and to design the failure-rate measuring techniques to give information about the proportion of failures in the "whole life."

At this point it is necessary to distinguish

(a) failures likely to occur early if they occur at all under the required working conditions,

(b) failures unlikely to occur until about the end of the required working life under the required working conditions, and

(c) the intermediate possibility⁴ of failures of a proportion of transistors within the required working life, particularly if the quality control of the manufacturing stages of the transistor is not adequate.

Typical of type (a) failures are those of internal wire bonds (either at the wafer or at the post end) and of wafer-to-header bonds, while the long-term diffusion of gold or other deleterious element into the silicon, causing degradation of one or more electrical parameters of the transistor, is typical of type (b) failure. Type (c) failures could arise, for example, from diffusion through defects in the protective oxide on the silicon at points close to the emitter or collector junctions. Thus, the type (a) failures are expected to be predominantly mechanical in essence though, of course, showing the electrical symptoms of open-circuits on the appropriate

external wires (or sometimes short-circuits if the internal wires have, after breaking at the silicon ends, been displaced sufficiently to touch another wire or post or the inside of the case).

Mechanical Failures

The determination of the mechanical failure rate resolves itself into observing the proportion of failures after subjecting a sufficient sample of transistors to direct or indirect mechanical stresses simulating or exceeding those expected under working conditions. Because the mechanical stress-versus-strain relationship for all materials and for all forms of stress shows a more or less sharp threshold beyond which catastrophic failure occurs, and because for static tensile or shear stress the ultimate strength of all the bonds in well-made planar transistors can be demonstrated to be many times the stresses that can be applied to them in civil applications, it is permissible and useful for test purposes to define mechanical failure as inability to withstand a test stress corresponding to, say, one-third of the ultimate strength for good transistors of the same type. As an additional safeguard against the possibility that mechanical weakness not detected by the test might develop during the operating life of the transistor, the transistors to be tested by the mechanical over-stress are first stored at 200–300°C for 24 hours or more to ensure that any weakening of the bonds due to the inter-diffusion mechanism mentioned earlier has proceeded as far as possible, so that the bonds, when tested, are in their weakest state.

The method at present most suitable for applying steady mechanical over-stress to completed transistors is to mount them in a centrifuge, suitably orientated and at a known distance from the axis, and to run this up to a known speed, producing a known acceleration on the transistor parts. As one gold bonding wire in a typical high-frequency transistor may have a mass of about 10 microgrammes, and as an acceleration of 60,000g is obtainable in a common type of centrifuge, a force of 0.6 grammes may be applied to the wire if the wire is free at one end to swing out radially in the centrifuge. In a completed transistor the wire is, of course, bonded at both ends, and if it is nearly straight between the bonding points and if the centrifugal force is nearly at right-angles to it the tensile force along the axis of the wire may initially be several grammes. Direct tensile tests on similar wire show that it may fail at a force of about 10 grammes (rather less for pure aluminium, but at a similar force for the commonly-used 1 per cent silicon-aluminium alloy). Thus, a realistic stress level can be attained by the centrifuge method if gold bonding wires are used in the transistors under investigation. Because the densities of aluminium and aluminium-alloy wire are about one-seventh that of gold, it is not at present so practicable to stress well-made aluminium-bonded transistors up to their failure point by using the centrifuge method on a routine basis. The method remains, nevertheless, a valid one for demonstrating the proportion of much weaker bonds, where "weak" still represents failure at an acceleration greatly above any value likely to be experienced during equipment construction or under working conditions.

It is also possible to produce destructive magnitudes of acceleration in transistor structures by means of ultrasonic vibrations. Thus 100,000g can be produced

at a frequency of 100 kc/s if the amplitude is about 2.5 microns. The wavelength of sound in the solids concerned at this frequency is still large enough for bulk resonance effects not to be serious—though structural resonance, in particular that of the wire, may be significant in causing damage at lower frequencies and lower applied amplitudes.

The presence of intense high-frequency vibrations may, however, introduce a new mode of failure—that of fatigue. The effect of fatigue might be to cause failure in a few minutes for a frequency of 100 kc/s with an amplitude of less than 1 micron. Fatigue failure would thus be a disturbing factor in the use of ultrasonic methods for measuring mechanical reliability. Because the amplitude needed to produce failure by vibration, either immediately or by fatigue, varies inversely as the square of the frequency, the likelihood of either of these types of failure in well-made planar transistor used in civil equipment can be regarded as negligibly small.

Mechanical shock tests have long been used as an empirical means of assessing the robustness of vacuum tubes and other components for military purposes, and have been found to produce failures in some types of planar transistors even though the nominal peak acceleration applied has not exceeded about 1,500g with a rise-time of the order of milliseconds. But it is now believed that, for well-made transistors, it is the 10,000–100,000g components of the shock wave with a rise-time of a microsecond or less that is most likely to cause mechanical failure. Methods of generating suitable shock-waves for transistor testing are still under development. Repeated shocks of high intensity could, as with vibration, lead eventually to fatigue failure. Again, as with vibration, the occurrence of immediate or fatigue failure by shock is regarded as a very remote possibility for well-made planar transistors used in civil equipment.

There remains nevertheless, another source of fatigue failure which may be significant in small transistors and is known to be so in larger transistors and diodes. This originates in the thermal expansion and thermal conductivity mismatches between the silicon wafer, the metal header or heat-sink, and the gold-silicon eutectic alloy that serves as the bonding material between the other two. Under steady-state electrical and thermal conditions in a planar transistor working at its full normal dissipation there may be a temperature difference of 20–50°C between the collector junction (i.e. nearly at the upper surface of the silicon) and the outside of the transistor case, leading to both radial and axial temperature gradients through the wafer-to-header bond. The structure is able to withstand the resulting mechanical stresses in the steady state, but in some structures, and, in particular, in devices with defective bonds covering only part of the wafer area, the bond itself or even the silicon wafer may fail by fatigue fracture on repeated cycling of the thermal stress, e.g. by a succession of power-overload surges. Similar effects may be brought about by temperature cycling over very wide ranges without electrical dissipation, and by thermal shock applied externally giving very high rates of change of case temperature.

Electrical Failures

One of the essential problems in estimating failure

rate, when the failures under normal working conditions are not expected to occur until after 10, 20, or more years of operation, is that of accelerating the aging mechanism by a known factor and with sufficient confidence. Another problem is the statistical one of extracting a maximum of quantitative information out of an economically feasible sample size—for the high temperature stresses used in some of the tests for the determination of electrical failure rate must be considered to rule out the subsequent use of the transistors concerned.

On the basis that the aging mechanisms for both type (b) and (c) failures are diffusion-controlled, as previously outlined, or at least that they are thermally-activated and thus obey similar relationships between life t and the junction or hot-spot temperature T , acceleration is achieved by raising T . In order to ensure that any effects that may be present on account of electric fields at the junctions, electric currents through the junctions or connexions, or temperature gradients in the active regions under users' working conditions are also present in a controlled way during the accelerated aging, it is considered desirable to achieve the accelerated T value by raising the ambient temperature, T_{amb} , or the case temperature, T_{caso} , of the transistors while keeping their electrical operating conditions as nearly the same as possible at all the T values. The electrical operating conditions should preferably be not too different from those to be used in the application of the transistor in the field. For silicon planar transistors suitable T values lie in the range 373–573°K (100–300°C), and at least two temperatures, about 50°C apart, should be chosen, the choice of the lowest being dictated by the need to obtain a significant number of failures within the maximum time available for the tests. It is usual to carry out preliminary small-scale tests, often using the step-stress technique, to assist the choice of the T values for the steady over-stress tests.

In the step-stress technique the transistors are aged for a series of equal periods of time t , the temperature T being constant during each period but being raised by about 20°C for each succeeding period, the steps of T continuing until at least 50 per cent of the transistors have one or more electrical parameters outside their limits.

While in a general investigation of transistor reliability it is not necessary to fix in advance the electrical-parameter limits to be used to define the several possible ends of useful life, it will be essential to have a fixed set of such limits, or, for some applications, limits on changes of certain parameters from their initial values for individual transistors, when any specific life prediction comes to be made about the transistor population from which the sample came. Thus it will be necessary to set end-to-life limits, or limits on changes, for most of the commonly-specified parameters, e.g. I_{CB0} , I_{EB0} , h_{FE} , $V_{(BR)CEO}$, $V_{CE(Sat)}$ and $V_{BE(Sat)}$. For some purposes it may be desirable to include limits on the noise figure and on the cut-off frequency or f_T , though in practice these are difficult to measure without removal of the transistors from the ovens used to establish T_{amb} or T_{caso} .

In the accelerated aging studies that have been in progress at the Post Office Research Station on silicon mesa and planar transistors since 1960, the aging circuit shown in Fig. 1 has been used for each transistor on test

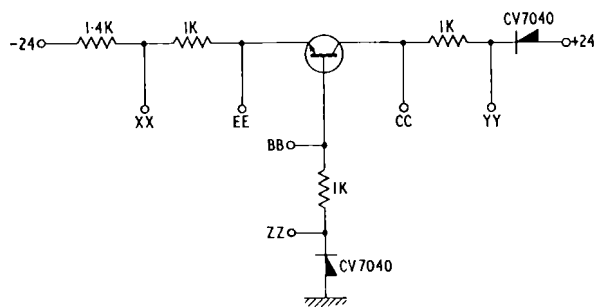

Parameter	Transistor conditions	Measure between
I_{E1}	Undisturbed	XX-EE
I_{B1}	Undisturbed	BB-ZZ
I_{E2}	XX via 150 ohms to earth	XX-EE
I_{B2}	CC via 1.6K to earth	BB-ZZ
I_{CBX}	ZZ to +10V. XX to -12V	CC-YY
I_{EBX}	ZZ to +10V. XX to -12V	XX-EE
$V_{BE(sat)}$	Earth EE. ZZ to +24V via 9.1K	BB-EE
$V_{CE(sat)}$	Earth EE. ZZ to +24V via 9.1K	CC-EE
$V_{BR(ONS)}$	ZZ to +10V. XX to +12V. +150V via 200K to CC	CC-BB

FIG. 1.—TRANSISTOR AGING CIRCUIT

This circuit was chosen as a compromise to satisfy the following conditions:

(i) The working emitter current is approximately stabilized by the series emitter resistors from the V_{EE} supply.

(ii) The collector dissipation is approximately stabilized, and always limited, by the collector series resistor from the V_{CC} supply.

(iii) There are no series contacts in the aging power supply to individual transistors, so that uncertainties as to the continuity of the power dissipation during the aging periods are eliminated (the aging circuit components are outside the ovens, and failures in these components have been negligible).

(iv) The transistors in the ovens have been free from high-frequency oscillation troubles, helped by the relatively low values of the resistors in the wires leading into the ovens (ferrite beads have also been used on the transistor leads).

(v) The parameters I_E and I_B (hence h_{FE} , at two values of I_E), I_{CBX} , I_{EBX} , $V_{BE(sat)}$, $V_{CE(sat)}$ and $V_{BR(ONS)}$ can be measured in terms of the voltages across suitable pairs of the test-access terminals shown while suitable bias supplies are applied to other suitable pairs, as listed in the table associated with Fig. 1; the silicon diodes in the aging circuit serve to permit certain of the conditions to over-ride the normal aging power supplies. The parameters I_{CBX} and I_{EBX} are similar to I_{CBO} and I_{EBO} except that the "other" junction is reverse-biased instead of open-circuited.

On each occasion of measurement, i.e. before and after each fixed aging period in a step-stress sequence, and at suitable times, usually such as to give approximately equal increments on a scale of $\log(\text{time})$, in a steady-stress test the T_{case} value has been brought down from the aging temperature to a reference temperature of 100°C and the parameters listed above have been logged digitally on punched paper tape by automatic equipment. This equipment applies the necessary

sequence of bias conditions, with suitable time delays between measurement of the parameters to allow the transistor-junction temperature to re-stabilize following the changes of dissipation from one bias condition to another. The transistors have been mounted in electrically-insulated thermal clamps in groups of 100 transistors on aluminium blocks, which serve to minimize both temporal and spatial temperature variations among the transistors. Manually or automatically operated selector switches outside the oven can be used to connect the data logger to each transistor in turn. The complete punched-tape record can be printed out for preliminary inspection, though it has been found more effective to use a computer to locate out-of-limit readings and to compare later with earlier tapes, before carrying out more elaborate analyses.

ESTIMATION OF FAILURE RATE UNDER USERS' OPERATING CONDITIONS FROM STEP-STRESS AND STEADY OVER-STRESS AGING DATA

Mechanical Failures

Detailed analyses of the dependence of the mechanical failure rate on stress level and stress duration are unnecessary for routine test purposes if the stress level needed to cause a significant proportion of failures is one or more orders of magnitude greater than that expected in the users' environment. It is then sufficient, yet not too stringent, to assume for the acceptance testing of samples from a production lot that each failure found in the sample as a result of over-stressing, to a level well below the ultimate failure stress of a well-made transistor but well above the maximum of the users' environment, represents a failure that could have occurred under the users' working conditions. It is then necessary to choose a sample size large enough to detect, with the required confidence, the proportion of failures that the user can tolerate. If the latter is 1 per cent with 95 per cent confidence the sample must contain some 500 transistors, but if the production is sufficiently uniform over long runs this sample, chosen randomly over the delivery lot, will be adequate for a delivery lot of 10,000 or 20,000, so that the cost of the transistors tested can remain only a few per cent of those delivered. If the stress levels adequately satisfy the above relationships, the test need not be regarded as destructive and the transistors surviving the test may be passed on to the user. A user requiring the utmost in reliability may call for such a test to be applied to all transistors delivered, but he should then also safeguard himself by requiring the manufacturer to use only approved bonding and encapsulating materials and techniques.

As an example of a detailed mechanical step-stress test sequence, three samples of 32 transistors selected from a delivery lot* of 2,000 transistors, by means of random number tables, were subjected to the following conditions. The three samples were each stored for 120 hours at, respectively, temperatures of 300°C, 320°C and 360°C. Each sample was then mounted in a centrifuge so that the force on the wire bonds was in the outward normal direction from the silicon surface. The centrifuge was run up to produce 10,000g for a few

*The transistors were of American manufacture and were obtained in 1962 to tightened limits of h_{FE} and $h_{f\alpha}$ (100 Mc/s): all specified parameters were logged on 100 per cent of the transistors both by the manufacturer and on receipt by the Post Office.

minutes and brought to rest to allow the transistors to be tested for open-circuits or short-circuits. This procedure was repeated on a given sample for successive accelerations of 20,000g, 30,000g, 40,000g, 50,000g and 62,000g, and the same sequence of accelerations was followed for all three samples. Only one failure, an emitter open-circuit, was found—and that after the 50,000g stress on the sample stored at 320°C. This low failure rate may be attributed in part to the inherently sound bonding technique used by the manufacturer and in part to his storing all the transistors at 300°C and centrifuging them at 20,000g to weed out mechanical weaklings before delivery.

Electrical Failures

Even though, as will be shown, only a very small percentage of electrical failures may be expected in the whole life of well-made planar transistors operated with hot-spot temperatures of 100°C or less, over-stress aging can produce up to 50 per cent failures within 1–10 per cent of the desired “whole life” if the end-of-life limits on the electrical parameters are stringent. One of the most demanding uses for transistors is in the amplifiers of long undersea telephone-cable systems. For such a use, because gain-changes in all the amplifiers are additive in their effect on the system, the tolerable change in h_{fe} (and therefore in h_{FE}) is small and for medium-length systems may be as little as 1.5 db if all the changes are of the same sign. The results of tests at the Post Office Research Station and elsewhere, on a particular type of planar transistor having gold-wire bonds, have shown that downward gain-changes are the predominant cause of “death” when a limit equivalent to 1.5 db change of h_{FE} is set, together with realistic limits on the other parameters. The following analysis is related to the type of failure just defined, but similar analyses may be applied for each definition of “death.”

In order to obtain an estimate of the temperature T for a given life t or of the life t for a given temperature T , at which a tolerable percentage of deaths occurs, it is necessary to make some assumption about the statistical distribution of deaths. Now, the diffusion mechanism considered earlier in this article leads to a linear relationship between $\log t$ and $1/T$ (where T is in °K), and for this reason it is usual to assume a normal (i.e. Gaussian) distribution of deaths with respect to $\log t$ and to $1/T$. It is thus convenient to use a cumulative normal probability scale for graphically plotting the percentage of deaths, with a scale of $\log t$ or $1/T$ according to the other variable; a scale of $1/T$ is appropriate for step-stress tests and of $\log t$ for steady over-stress tests.

Fig. 2, 3 and 4 show graphs derived from test data, Fig. 2 and 3 being from step-stress tests and Fig. 4 from steady over-stress tests. In each of these graphs the actual points plotted are the results of interpolation by computer between the experimental $1/T$ or $\log t$ values and the corresponding changes in I_{E1} (Fig. 1 table) from initial values, to locate more precisely the position at which the parameter crossed the “death” limit. It should be noted from the table associated with Fig. 1 that I_B and I_E are actually logged; h_{FE} is then given from the relation $I_B/I_E = (1 + h_{FE})^{-1}$; as I_E is stabilized to a value nearly independent of the transistor characteristics, changes in I_B are most significant and have been used in defining end-of-life for the present

analysis. The effect of the interpolation is to reduce the systematic spread of the plotted points that would otherwise occur about the best-fit line due to the limited sample size and the necessarily discrete intervals of $1/T$ and $\log t$ at which measurements were taken. The straight lines shown on each graph have been fitted by computer by a weighted least-squares procedure making use of order statistics,⁵ which result in low weights being given to the low-percentile points.

Fig. 2 relates to step-stress tests of 20 hours per step on two different samples of 30 transistors selected by random numbers from a large population. The

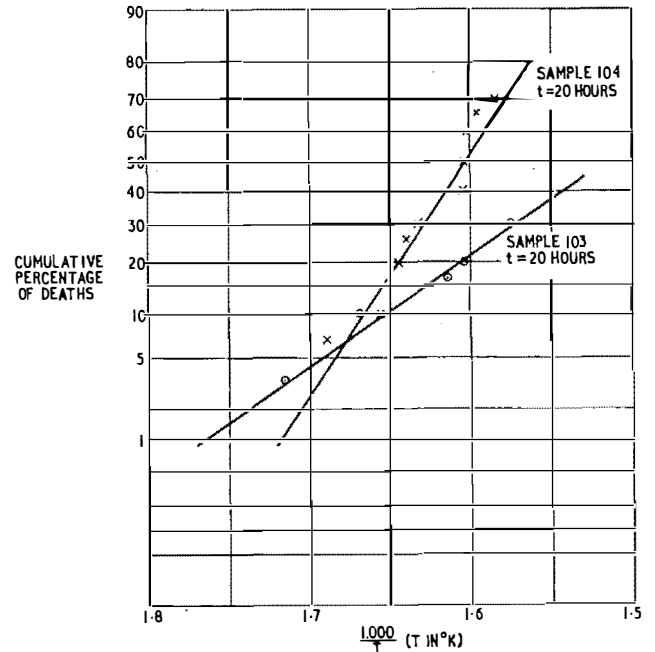

FIG. 2—20-HOUR STEP-STRESS TESTS WITH 30 TRANSISTORS IN EACH SAMPLE

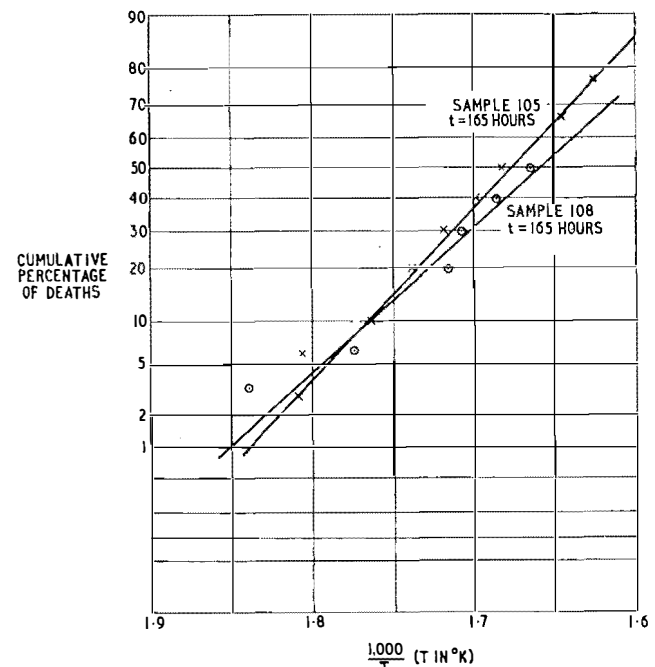

FIG. 3—165-HOUR STEP-STRESS TESTS WITH 30 TRANSISTORS IN EACH SAMPLE

differences between the medians and between the variances for the two best-fit lines (both of which make use of all the relevant data points) are probably a consequence of the small sample sizes.

Fig. 3 relates to step-stress tests of 165 hours per step on two more random samples of 30 transistors from the population. The sampling differences are here seen to be smaller than in Fig. 2.

Fig. 4 relates to two steady over-stress tests, each on a different random sample of 200 transistors from the

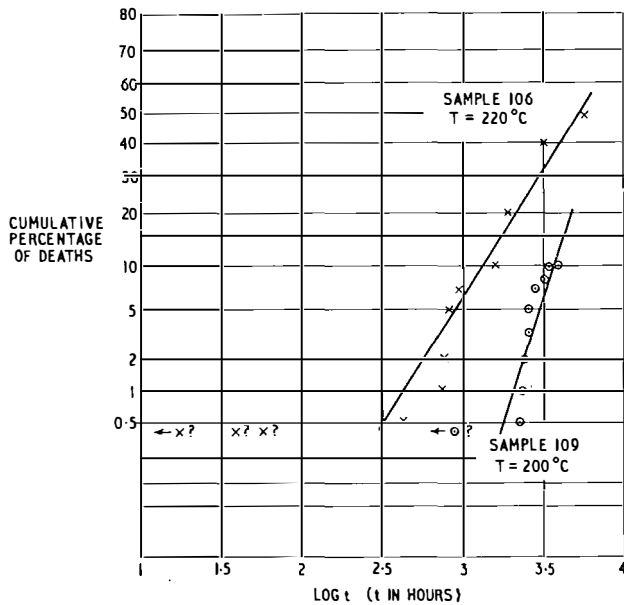

FIG. 4--STEADY OVER-STRESS TESTS WITH 200 TRANSISTORS IN EACH SAMPLE

same population as for the other tests. In one test the transistor hot-spot temperature was about 220°C, and in the other about 200°C. For each of these two tests the results showed failures at about the 1 per cent level, far off the trend line for the remainder of the failures. The small number of these low-percentile failures has made it impossible to assign them to another superimposed distribution, but they are regarded as potential type (c) failures pending the accumulation of further evidence. The best-fit lines in Fig. 4 have been computed with the exclusion of the anomalous failures.

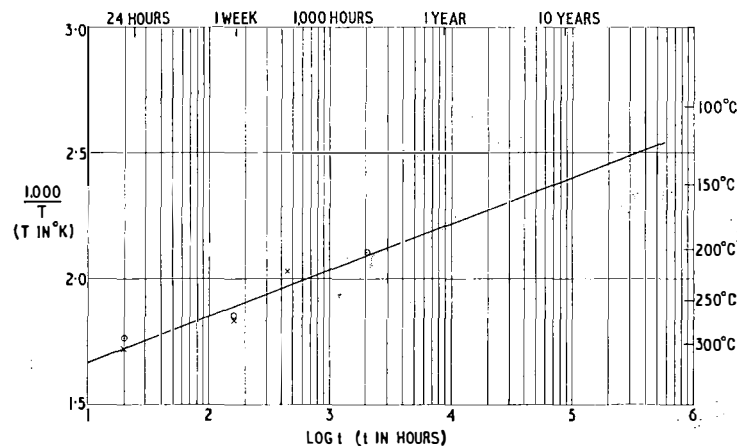

FIG. 5--LIFE PREDICTION LINE

The final step in the estimation of the failure rate is shown in Fig. 5, where the "life-prediction line" has been drawn, to scales of $\log t$ and $1/T$, for a failure proportion of 1 per cent, this value being chosen for illustration. This particular line is a weighed best-fit to the six points shown, two points being taken from each of Fig. 2, 3 and 4. Thus, extrapolation of the best-fit lines in Fig. 2 to the 1 per cent level fixes corresponding values for $1/T$, the step-stress duration of 20 hours fixing $\log t$. Similar extrapolations are made in Fig. 3, but here $\log t$ is fixed by the 165-hour-step duration. Extrapolation of the best-fit lines in Fig. 4 to the 1 per cent level fixes corresponding values for $\log t$, and the related values of $1/T$ are determined by the steady over-stress hot-spot temperatures of 220°C and 200°C.

Extrapolation of the life-prediction line then shows that not more than 1 per cent of the transistors may be expected to deteriorate by more than 1.5 db in gain in 25 years of operation if their hot-spot temperature is kept below about 100°C throughout that period. This conclusion must, however, be qualified by the possible presence, in the particular population of transistors studied, of about another 1 per cent for which the gain may deteriorate more rapidly, as indicated by the anomalous early failures in Fig. 4. In order to provide further information about this type of failure, a sample of 100 transistors is being aged at a hot-spot temperature of about 70°C. The data after about 4,000 hours, though more subject to measurement errors than the earlier data, suggest that the gain of a few transistors has risen rather than fallen significantly.

CONCLUSIONS

The results summarized in the preceding paragraphs are related to a particularly stringent criterion for end-of-life. Degradations of other parameters besides current gain, and, in particular, of collector breakdown voltage have been the symptoms of failure for some transistors, and these may become dominant symptoms for users not needing such highly-stable gain. On the other hand, a significant number of transistors have shown negligible change of gain throughout the steady over-stress tests up to the times shown in Fig. 4, thus suggesting that the gain-change may not be a fundamental weakness of the structure used.

The slope of the life-prediction line in Fig. 5 corresponds to an activation energy of about 1 electron-volt, but more specific physical evidence will be needed before the aging can be ascribed positively to the diffusion of gold or another element.

The transistors, to which the results here reported apply, had a cut-off frequency of about 440 Mc/s and a usable power dissipation of about 300 mW. The shallower junctions and more critical geometry needed for transistors having higher cut-off frequency, particularly when this is combined with higher power dissipation, will tend to reduce reliability unless increasing attention is given to this danger in the choice of materials and technology. The elimination of suspect materials from sensitive parts of the structure, without undue sacrifice of other desirable properties, may then determine the direction of further development for applications where the utmost in reliability is essential. The control of quality in production will necessitate 100 per

cent inspection at all critical stages, and the assessment of the reliability of the product will require the use of very large samples where the end-use is such as postulated above in the Introduction. For most other Post Office end-uses, however, much smaller samples will be permissible for this purpose, and most users may therefore benefit to an adequate degree, at little extra cost, if their needs can be channelled into few types and large delivery lots, from the breakthrough in attainable reliability which accompanied that in frequency response with the development of the silicon planar technology.

ACKNOWLEDGMENTS

The authors are indebted to their colleagues, Mr. I. E. Bryan for the centrifuge step-stress data quoted in this article, and to Mr. W. J. Frankton and Miss B. F. Thorne of Submarine Cables, Ltd., Erith, for their

collaboration in the conduct of the electrical step-stress and steady over-stress tests from which the results summarized in the article were obtained.

References

- ¹ ROBERTS, F. F., HENDERSON, J. C., and HASTIE, R. A. An Accelerated Aging Experiment on Germanium p-n-p Alloy-Type Transistors. *Proceedings I.E.E.*, International Convention on Transistors and Associated Semiconductor Devices, May 1959 (Vol. 106, Part B, Supplement No. 17, p. 958).
- ² HENDERSON, J. C., and WILSON, Sylvia J. Design and Technology of Silicon Planar Transistors. *P.O.E.E.J.*, Vol. 56, p. 239, Jan. 1964.
- ³ WEAVER, C., and BROWN, L. C. Diffusion in Evaporated Films of Gold-Aluminium, *Philosophical Magazine*, Vol. 7, p. 1, Jan. 1962.
- ⁴ HENDERSON, J. C. Assessment of Transistor Life. *P.O.E.E.J.*, Vol. 53, p. 236, Jan. 1961.
- ⁵ PLACKETT, R. L. The Analysis of Life Test Data, *Technometrics*, Vol. 1, p. 9, Feb. 1959.

A Portable Emission Tester for Hot-Cathode Mercury-Vapour Rectifiers

S. J. SELLWOOD and R. R. KIRKBY†

U.D.C. 621.317.799:537.581:621.387.122.221

A portable tester for checking the emission of hot-cathode mercury-vapour rectifier valves of the types commonly used for high-tension direct-current power supplies is described. The new tester has been developed for use at British Post Office radio transmitting stations.

INTRODUCTION

HOT-cathode mercury-vapour rectifier valves are used extensively to provide high-tension d.c. supplies for radio transmitters, and a typical transmitter of 30 kW peak-power output may be equipped with as many as 15 rectifier valves providing various d.c. voltages ranging from 1.5 to 10 kV.

†Overseas Radio Planning and Provision Branch, E.-in-C.'s Office.

The portable emission tester described in this article has been developed to facilitate routine testing of hot-cathode mercury-vapour rectifier valves at transmitting stations. A separate filament power-supply unit has been designed to enable the rectifier valves to be tested on the bench independently of a transmitter. This power-supply unit incorporates a filament power-supply transformer with a Variac control for voltage adjustment, and is fitted with sockets for most types of rectifier valve in common use; extension filament leads are also provided for large rectifiers that do not utilize plug-in connexions. The emission tester and filament power-supply unit are shown in Fig. 1.

An undesirable characteristic of hot-cathode mercury-vapour rectifiers is the occasional momentary break-

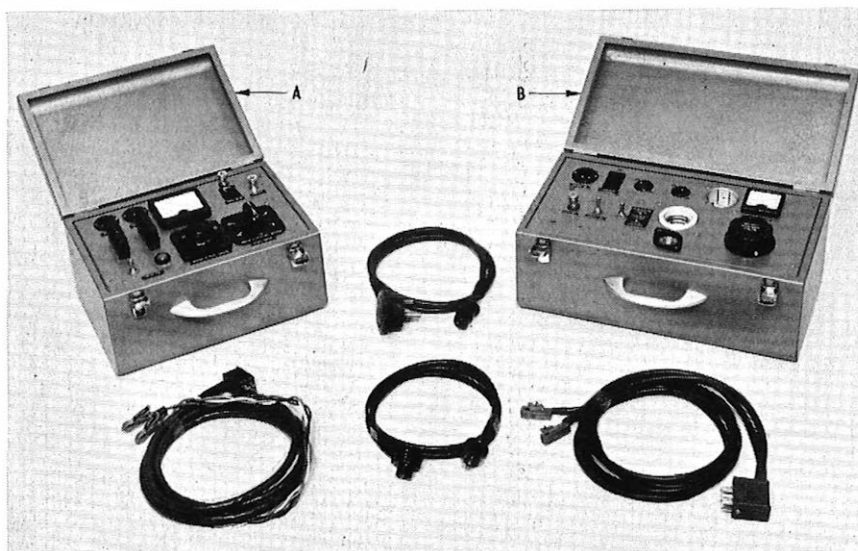

A—Emission tester B—Power-supply unit
FIG. 1—EMISSION TESTER AND FILAMENT POWER-SUPPLY UNIT

down of the ionized gas, causing the rectifier to conduct heavily in the reverse direction. This is known as "arc-back" and usually causes operation of the overload protection relays in a transmitter, thereby interrupting services. The exact mechanism of arc-back is not yet fully understood¹ although the phenomenon has been subject to investigation and research for many years. However, it is generally considered that breakdown is initiated by the charging-up of small non-metallic particles on the anode by residual ions accelerated in the inverse field. When the charge on the particles produces a potential gradient of about 10^6 volts/cm, runaway field emission leads to a cathode spot and arc-back.² The tendency to arc-back increases with the approach of the end of the life of a rectifier valve, when its cathode emission is diminishing; the interruptions to traffic therefore become more frequent at this time. Identification of a faulty valve or valves prone to arc-back in polyphase rectifier systems is always difficult, as the reverse-current indicators, which are usually fitted in each valve circuit, often fail to give satisfactory discrimination. It is, therefore, desirable to test hot-cathode mercury-vapour rectifier valves at regular intervals.

MEASUREMENT OF RECTIFIER-VALVE EMISSION

The cathode emission available in a mercury-vapour rectifier is indicated by its internal resistance under peak-emission conditions. This internal resistance is

cycle and peak current is sustained only momentarily. However, a heavy space current of too long a duration will raise the cathode temperature above normal and give rise to a spurious increase in emission, and, at the same time, increase the vapour pressure, thereby reducing the internal resistance. If the high current persists, both cathode and anode may be damaged. To overcome these difficulties the peak emission is usually measured when the rectifier valve is conducting only very short pulses at peak current, the voltage drop between anode and cathode being indicated on an oscilloscope.

In the past this has required bulky and complex equipment with large d.c. power supplies to cater for high peak currents up to the order of 30 amp, a pulse generator, and suppression of the oscilloscope trace while the rectifier valve is not conducting. In the new portable tester a mercury-vapour rectifier is connected, via a current-controlling resistor, across a single-phase 240-volt supply for a short period, and, as the rectifier conducts only during half cycles, the peak voltage drop across the valve under test can be indicated by a specially scaled d.c. voltmeter. The measurement is made over a short period determined by the tester timing circuit.

TESTER CIRCUIT DESCRIPTION

The circuit diagram of the tester is shown in Fig. 2. The potential difference between the anode and cathode

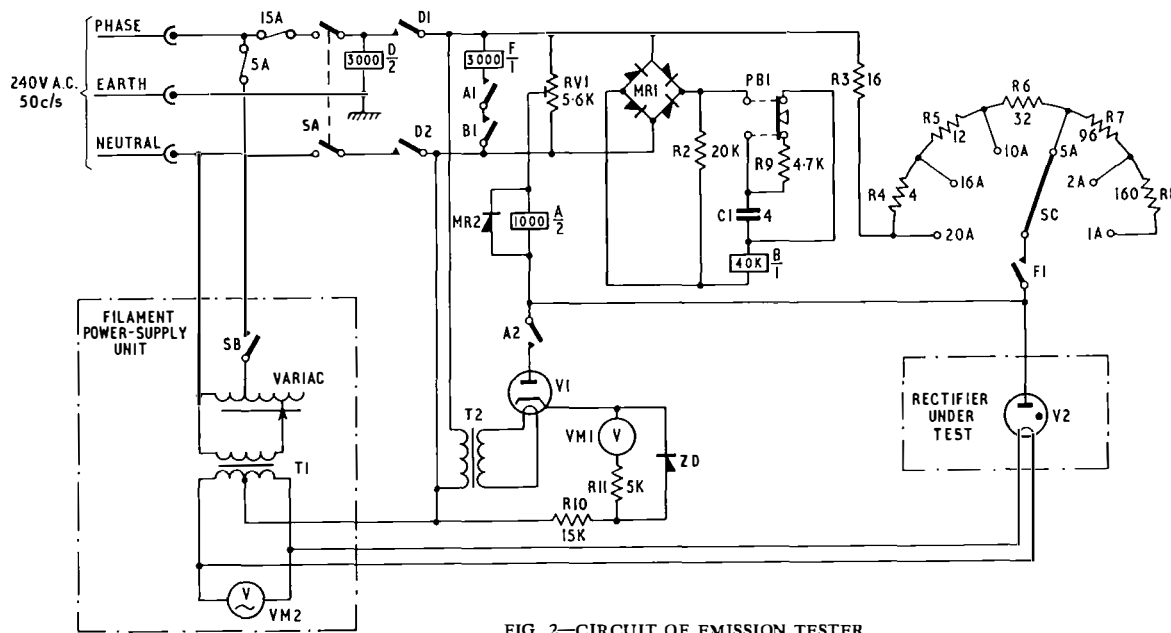

FIG. 2—CIRCUIT OF EMISSION TESTER

usually measured by observing the voltage drop between anode and cathode when the rectifier conducts a pulse at maximum current. The peak-emission rating of a mercury-vapour rectifier is generally several times the average continuous current specified for normal operation, because the valve conducts for a part of each a.c.

of the hot-cathode mercury-vapour rectifier under test (V2) is measured during the conductive half-cycle by voltmeter VM1, the negative half-cycle of voltage being blocked-off by diode V1.

With power applied and contacts SA, D1 and D2 closed, a priming current of a few milliamp operates relay A when rectifier V2 strikes with about 60 volts a.c. applied to its anode. This ensures that rectifier V2 is conducting before the voltmeter is connected by contact A2, and the peak-emission test can then proceed. The priming current is determined by the resistance of vari-

¹ KNIGHT, H. de B. The Relation of Arc-Back to Ion Density and Inverse Field in Arc Discharge Rectifiers. *British Journal of Applied Physics*. Vol. 13, No. 12, p. 606, Dec. 1962.

² KINGDON, K. H., and LAWTON, E. J. Arc-Back in Low Pressure Gases. *General Electric Review*, Vol. 42, p. 474, 1939.

able resistor RV1, relay A and rectifier V2. The voltmeter reads approximately the value to be expected when rectifier V2 is passing its full peak current; a typical value for a good rectifier valve is 10–15 volts. When relays B and F are operated by depressing push-button PB1 the rated peak current passes through V2, via the selected current-range resistors R3–R8, during the period that contact F1 is closed. Although the peak current passes for only 250 ms, as determined by the time during which relay B is operated by the charging of capacitor C1, the pre-positioning of the voltmeter needle enables any changes from the initial reading to be readily assessed. If the rectifier under test has adequate emission, the change from priming to peak current will cause only a small change, but with failing emission the peak-current pulse will give an appreciable increase in the reading.

An inherent characteristic of mercury-vapour rectifiers is that the anode-cathode voltage drop remains substantially constant over the working range of space current, and, therefore, if sinusoidal a.c. is applied via a current-limiting resistor, the waveform of the voltage across the rectifier is approximately rectangular. As the peak-to-mean ratio of such a voltage is 2:1, the deflexion of the moving-coil d.c. voltmeter VM1 will be proportional to the mean value. It is, however, scaled to read peak values corresponding to the anode-cathode drop. A Zener diode, ZD, limits the voltage to that for a

full-scale deflexion of 40 volts peak, protecting the meter against damage when testing a rectifier valve with very low emission.

Although the peak space current is passed for only a relatively short time, it tends to raise slightly the cathode temperature of the valve under test and thereby enhances the emission. To prevent false readings due to this effect, push-button PB1 has a slow reset action of about 2 minutes, which prevents the emission test from being repeated until the cathode has had time to restore to its normal temperature.

To guard against the possibility of wrongly connected wiring in the mains socket-outlet of the a.c. supply to which a tester may be connected—a condition which could introduce a risk of electric shock to the operator—a protection circuit is incorporated. This prevents the operation of relay D, thereby disabling the tester unless the phase side of the mains is connected to the correct pin.

CONCLUSIONS

The tester enables the peak emission of a mercury-vapour rectifier valve to be checked at a low voltage derived from the mains supply, and is capable of giving a short pulse of current up to 20 amp peak, which is sufficient for testing even the largest high-voltage rectifier valves in general use at British Post Office radio transmitting stations.

Book Reviews

“Vacuum and Solid State Electronics—An Introductory Course.” D. J. Harris, B.Sc.(Eng.), Ph.D., A.M.I.E.E., and P. N. Robson, B.A., A.M.I.E.E. Pergamon Press, Ltd. xiv + 254 pp. 129 ill. 20s.

The book is intended as a student's introduction to electronic devices and their fundamental principles, rather than to their circuit applications, though some material on elementary circuits is included. The sections dealing with the physics of vacuum and solid-state electronics form good introductions to the chapters on thermionic valves and semiconductor devices which follow. The section dealing with the operation of junction diodes and transistors is extremely well written; it covers important details which are often omitted, and is at the same time very readable. It is, however, unfortunate that the very important topic of diffused-base transistors has been completely ignored, both here and in the description of manufacturing processes. There is some duplication; much of the material in a portion of Chapter 5 dealing with transistor amplifiers is repeated in Chapter 6. The book closes with two chapters on electronic circuits and the cathode-ray tube, but the important topic of the transistor as a switch is not mentioned.

There are one or two mistakes: J. J. Thomson's name is misspelt, and it is stated that a magnetic field cannot change the speed of an electron, which is untrue for a time-varying field. On page 165 it is implied that the base-collector current gain of a transistor is $\alpha/1 - \alpha$ when a load resistance is present.

Despite these criticisms, the book is commended as a compact and easily read introduction to its subject.

H.G.B.

“Introduction to Microwave Practice.” P. F. Mariner, B.Sc., A.R.C.S., A.Inst.P. Heywood & Co., Ltd. iv + 238 pp. 175 ill. 50s.

Microwave engineering has been growing very rapidly and its application to the telecommunications service has come to be accepted as routine in the Post Office. Most workers in this field of radio have learnt the rudiments of the subject the hard way, i.e. by practical experience, just as some children are taught to swim by “being thrown in at the deep end.” However, books are now coming along that offer a good grounding in the subject to people already in telecommunications engineering, and this work is in the forefront of this class. The author states that only a “limited knowledge of electrical circuit theory and simple calculus” is assumed, which should encourage the university student as well as the practising engineer to dip into the book. In the first part of the book he deals, with the aid of very clear field diagrams, with propagation in waveguides, with reflected waves and voltage standing-wave ratios, and how measurements on waveguide characteristics are carried out. Waveguide components of most of the conventional types are discussed in varying degrees of detail, including a brief introduction to travelling-wave tubes and klystrons, applications of the Faraday effect and the properties of ferrites. Appendices on vector algebra, and Maxwell's equations and field functions will be welcome to those who wish to revise their mathematics to the stage really needed for a detailed study of microwave transmission problems.

This book is to be recommended to a man branching out into microwaves after having worked on more orthodox forms of telecommunications engineering. It will also be welcomed by university students seeking a wider background than usually accompanies lectures on microwave theory.

I.P.O.E.E. Library No. 2682.

C.F.F.

The Cleansing of Telephones

U.D.C. 614.4:621.395.6

THERE is a public demand, fostered by advertising, for the regular disinfection of telephones that are in common use by a number of people. Medical opinion is that, except in special circumstances, the risk of cross-infection from the use of a telephone is negligible, and disinfection is therefore unnecessary. The Post Office is nevertheless willing to allow subscribers, who so desire, to have their telephones cleansed by firms operating under licence, provided that, amongst other conditions, the cleansing fluid used has been approved by the Post Office Engineering Department. This condition is imposed in order that instruments may not be damaged by the application of unsuitable substances.

A firm wishing to start a service of this sort is required to submit a sample of the fluid they propose to use to the Post Office Engineering Department, where it is analysed by the London Materials Section of the Test and Inspection Branch, and submitted to tests to determine its effect on the various materials of which the telephone is composed. Quite often the fluid submitted is found to be one of the ordinary household disinfectants that contain soap as a stabilizer; the use of these cannot be allowed, since not only do they leave a sticky residue, but the soap is alkaline enough to attack the aluminium diaphragm of the transmitter. Again, coal-tar phenols (the carbolic acid of common parlance) and the terpenes often used as odourants (pine oil and so on) are examples of substances that are objectionable because of their solvent action on plastics.

The Engineering Department has been pressed on a number of occasions to provide a formula for an acceptable cleansing fluid (usually after the applicant's own fluid has been rejected), and in 1964 the use of a weak solution of formaldehyde (formalin) with the addition of a little thymol was suggested. Although this is not a particularly effective disinfectant it was harmless to telephone instruments and left a slight fresh odour as evidence that the instrument had been cleansed. Its dirt-removing power is, however, no greater than that of plain water. In addition to this formalin solution a number of proprietary fluids were approved, but the introduction of the 700-type telephone* made it necessary to re-examine the situation, since some of these fluids, although harmless to the old-type phenolic moulding, were capable of damaging the surface of the new acrylic mouldings, which are less resistant to solvents. This effect is also shown on the ABS (acrylonitrile-butadiene-styrene) mouldings that are now replacing acrylic as the material for telephones.

At about this time the question of the cleansing of operators' headsets was causing some difficulty, since the liquid then being used was causing discolouration of the nylon mouldings. Medical advisers suggested cetrimide as a suitable disinfectant, and it was established that in a suitable dilution, this material was harmless to the instrument. It is of interest that cetrimide was chosen as

a result of an investigation into the sterilization of telephones in hospitals, where there is a real need for this precaution. Further investigation showed that cetrimide was also suitable for cleansing subscribers' telephones, with the added advantage that it is a mild detergent and a fairly good anti-static agent. Although telephone mouldings are given a polish with an anti-static cloth before they leave the factory this treatment is not permanent and in service the surface soon begins to attract dust, particularly in the dry air of a centrally heated building. Attempts to remove this dust by rubbing with a dry duster only aggravate the trouble, but a wipe with a cloth moistened with weak cetrimide solution restores

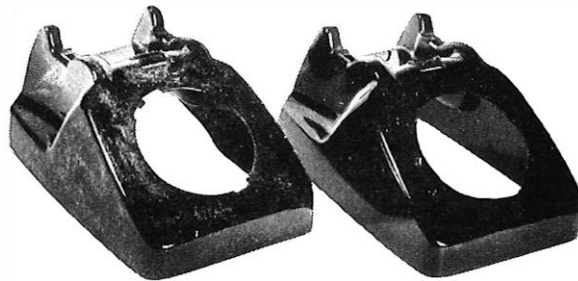

The right-hand case was wiped with Cetrimide solution, the left-hand case was untreated. Both were then polished and exposed to dust (cotton lint).
THE EFFECT OF ANTI-STATIC TREATMENT OF TELEPHONE MOULDINGS

the anti-static surface for a time; this effect is shown in the figure.

Cetrimide, or cetyl pyridinium bromide, to give it its full chemical name, is a quaternary ammonium salt, and cationic detergents of this type are in common use industrially and as an ingredient in proprietary disinfectants and detergents. Other materials of this class are better anti-static agents, but cetrimide appears to offer the best combination of disinfectant, anti-static and detergent properties. The use of a 0.2 per cent solution, † prepared locally from material that can be bought from a pharmacy, is now standard practice for the cleansing of all types of telephones in the Post Office. Firms licensed to cleanse subscribers' telephones are also permitted to use fluid of this composition, with the optional addition of an odourant that should not contain alcohol or other substances having a solvent action on the moulding material. Even this dilute solution would, of course, be objectionable if injected into the earpiece or mouthpiece of the instrument, and the licensees are only allowed to wipe the external surfaces of the instrument with a moist cloth; sprays must not be used.

P.E.T. and L.E.T.

*WILSON, F. A., and SPENCER, H. J. C. The New 700-Type Table Telephone—Telephone No. 706. *P.O.E.E.J.*, Vol. 52, p. 1, Apr. 1959.

†Cetrimide solution may be prepared either from the dry powder known as "Cetrimide BP" or by suitable dilution of "Cetavlon Cetrimide Concentrate," which is available in forms containing either 20 per cent or 40 per cent of cetrimide. It is also occasionally met in other forms such as an alcoholic solution, but these are not suitable for telephone cleansing because of the possible harmful effects of the other ingredients.

Jointing of Cables Containing Type 174A Small-Diameter Coaxial Pairs

H. E. ROBINSON and F. W. ANGELL†

U.D.C. 621.315.687.1 : 621.315.212

The established methods of making conductor joints in telephone cables, namely, the use of the crank-handle twist and of the soldered ferrule, have been proved in more than 50 years of jointing practice to be economic and reliable for the types of cables for which they are used. Now, the far-reaching changes taking place in the design of cables call for new and better jointing methods.

INTRODUCTION

THE first experimental polythene-sheathed cables containing small-diameter coaxial pairs and polythene-insulated control pairs (coded Cable, Coaxial, No. 163A) were installed in 1959. It is not surprising that the method used for jointing the coaxial pairs was a small-scale version of that used for 375-type coaxial pairs and therefore made use of ferrules for jointing the centre and outer conductors. The experiment showed that even the most-experienced coaxial-cable jointers had difficulty in making consistently satisfactory joints with such small piece-parts, and it was realized that the success of cables containing small-diameter coaxial pairs would largely depend on finding a new and more reliable method of jointing.

Within a few weeks a new type of cable joint was devised and developed, eliminating piece-parts altogether. Brazed joints for the conductors, combined with welding techniques for jointing the polythene insulation and the cable sheath, were introduced for the first time in the jointing of inland cables. The new type of joint was an outstanding success, and the technique of braze-jointing the coaxial pairs has now been standardized for 163-type coaxial pairs and for the slightly larger diameter 174-type introduced more recently. Cables containing 174-type coaxial pairs have protected lead sheaths, paper-insulated control pairs and, in some instances, paper-insulated layer pairs.

Sizes of 174-Type Coaxial Cable

Standard 174A-type small-diameter coaxial cable is available in a number of sizes, ranging from a cable containing a single coaxial pair to a composite cable containing eight coaxial pairs, 10 10 lb/mile paper-core twin interstice pairs and 444 20 lb/mile paper-core quad trunk layer pairs (see Appendix).

Design of Coaxial Pair

The inner conductor of the 174A-type coaxial pair consists of a uniformly-drawn solid-copper wire, circular in section, having a nominal diameter of 0.047 in. (36 lb/mile) and a nominal resistance of 25 ohms/mile at 15°C. The outer conductor consists of a tape of soft copper 0.0070 in. \pm 0.0003 in. thick formed into a tube around the insulated inner conductor. The internal diameter of the tube so formed is nominally 0.174 in.,

and the nominal resistance of the tube is 10.7 ohms/mile at 15°C.

There are various ways of locking the tube to prevent movement at the edges, e.g. by notching the edges of the tape, by corrugating them, or by argon-arc welding the edges together. The British Post Office does not specify how it should be done, and each manufacturer uses the method suited to his cable-making machines.

The physical arrangement of the polythene insulation, to maintain the relative positions of the inner and the outer conductors, varies according to individual manufacturer's designs; details of these have been given in an earlier article in this Journal.* At one period in the development of the small-diameter coaxial pairs it was thought that the different designs of spacers would make it impossible to develop a common jointing method. Cable manufacturers were, however, aware that it was essential that all designs of standard small-diameter coaxial pair should be compatible for jointing purposes, and by making minor changes in two of the types a common jointing method was assured.

For screening purposes, two annealed mild-steel tapes, each having a nominal thickness of 0.004 in., are applied helically over each outer-conductor tube. The inner tape is applied with a left-hand lay and the outer tape with a right-hand lay. The coaxial pairs are insulated by at least two thicknesses of insulating paper, neutral in colour, lapped helically over the steel tapes. The outer paper bears the identification number of the pair.

BRAZING UNIT AND HAND-TOOLS

The brazing unit and its associated hand-tools are illustrated in Fig. 1. The unit is contained in a metal case and is mounted on a panel of heat-resisting insulating material; the chief components are a heavy-duty switch and a resistor. Tappings from the resistor are wired to five outlet sockets labelled to show the size and type of conductor that each tapping will braze. A hinged bar, mounted on the top of the panel, facilitates foot operation of the control switch. An additional socket, which is wired through a separate toggle switch, provides a 24-volt supply to heat a pair of tongs for welding polythene; the tongs are used to heat-seal the polythene insulation of the coaxial pairs and control pairs of 163-type coaxial-cable joints.

A pilot lamp is fitted on the panel to give the operator a visual indication that the power supply is connected, and ventilation louvres are provided in the sides and in one end of the case to dissipate the heat developed in the resistor during brazing operations. A clip-on cover with a carrying handle gives protection to the outlet sockets and provides a storage place for the battery leads when the unit is not in use. A clip-on tray on the bottom of the unit provides storage space for the hand-tools. The complete unit, which weighs approximately 30 lb, is compact and portable.

Power for the unit is obtained from the standard 24-volt d.c. lighting sets that are issued to jointing parties.

† External Plant and Protection Branch, E.-in-C.'s Office.

* ALLAN, A. F. G. Small-Diameter Coaxial Cable Developments. *P.O.E.E.J.*, Vol. 57, p. 1, Apr. 1964.

Joining the Coaxial Pairs

The method described is that used for making joints in the coaxial pairs of a British Post Office 4-pair 174A-type cable having the "bamboo" or "balloon" types of polythene insulation. The method is basically the same for 163-type coaxial pairs and for makes of 174-type pairs having other designs of insulation.

Rubber formers are inserted between the coaxial pairs and positioned with their small ends approximately 1 in. from the cable butts, as shown in Fig. 2(a). The formers serve to assist in setting the pairs so that they lie straight and parallel to one another with just sufficient separation for joining them. After the pairs have been jointed, the formers remain to support them and to give access for maintenance purposes.

The coaxial pairs **must** be so arranged that pair-identification numbers on one side of the joint coincide with the pair-identification numbers on the other side. In practice, however, similarly-numbered pairs seldom do coincide when the cables are set in position for jointing, and they may be displaced by as much as 180°. By a repeated process of very carefully twisting the cable ends, a little by the sheath and then a little by the core, the pairs can be brought into alignment. The ease with which this can be carried out depends upon the looseness of the core within the sheath and great care is always necessary to avoid straining the outer-conductor tubes.

The pair farthest from the jointer's working position is selected for jointing first, followed by the pairs on each side of it and, finally, by the pair nearest the working position. On the "down" side of the joint the paper tapes and the steel tapes are removed from the tubes, and on the "up" side the paper tapes are unwrapped and loosely tied aside. The steel tapes are rolled up by means of a special tool, in the reverse direction to their normal lay. The coaxial pairs on both sides of the joint are then cut with side-cutting pliers at a distance of 5 in. from the large ends of the formers (Fig. 2(b)).

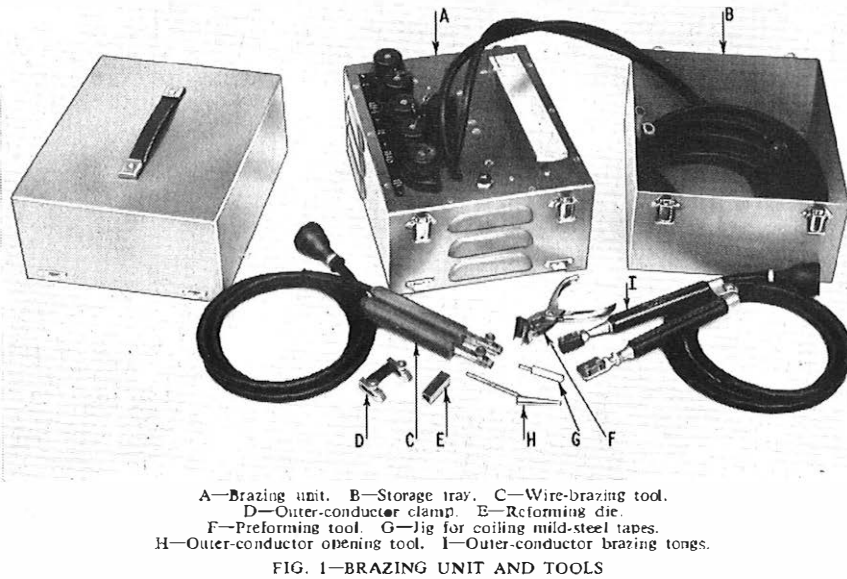

It is desirable that two fully-charged batteries should be connected in parallel across the output of the 24-volt generator.

Outer-Conductor Brazing Tool

The tool for brazing the outer conductor consists of a pair of soldering tongs fitted with carbon electrodes of a grade found by experiment to be the most suitable for brazing the copper tapes. Heat produced in the carbon electrodes is conducted through the copper tapes to melt the brazing alloy, which fuses the ends of the copper tapes together.

Wire-Brazing Tool

The wire-brazing tool consists of a pair of conductors with insulated handles that have a parallel closing action when squeezed by hand. In this instance the heat required for brazing is developed by the resistance of the wires being jointed. The greatest heat is developed at the junction of the wires where the ends are held in contact with the brazing alloy.

Small Hand-Tools

The following small hand-tools are also included in each brazing unit.

(i) A jig to coil up the mild-steel screening tapes.

(ii) A tool to open the outer-conductor tubes.

(iii) A clamp to hold the outer-conductor tapes together for brazing.

(iv) A split die to reform the outer-conductor tapes to their original tube formation.

(v) A tubular guide for use when scoring argon-arc welded tubes prior to opening them with the outer-conductor opening tool.

(vi) A performing tool to partially reform the outer-conductor tape so that the reforming die can be used more effectively.

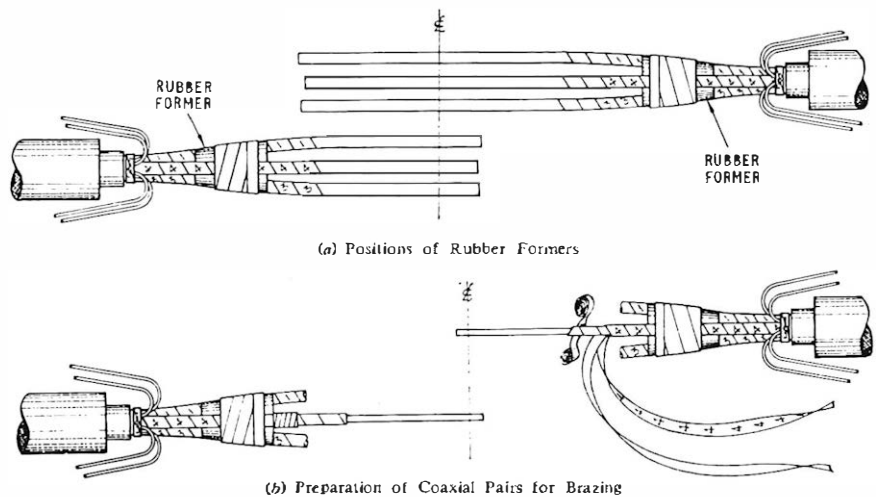

FIG. 2—PRELIMINARY STAGES IN JOINTING 4-COAXIAL-PAIR CABLE

Brazing the Outer Conductors. The sequence in which the conductors of a coaxial pair are joined by brazing is the reverse of that when a ferrule is used, as, for example, in joining a 375-type coaxial pair. For pairs having outer-conductor tubes that are not seam-welded, a tube-opening tool is pushed along the pair to open the tube for a distance of approximately 3 in. The tube-opening tool is a form of hollow cone that allows the centre conductor and the polythene insulation to pass freely through it as it is pushed forward. For cables containing seam-welded tubes a longitudinal scoring jig is passed over the tube; the tube is scored with the point of a sharp knife and then opened with the opening tool as previously described. The ends of the opened tubes are flattened, aligned and clamped with a small overlap. The inner conductors and polythene insulation are bent upwards and away from the clamped tapes (see Fig. 3). The tapes are then cut squarely with scissors so that their ends just butt.

A strip of silver solder $\frac{5}{8}$ in. long, $\frac{1}{16}$ in. wide and 0.005 in. thick, is placed at the junction of the butted tapes on the faces remote from the inner conductors. The ends of the strip of silver solder are turned over the edges of the tapes and crimped.

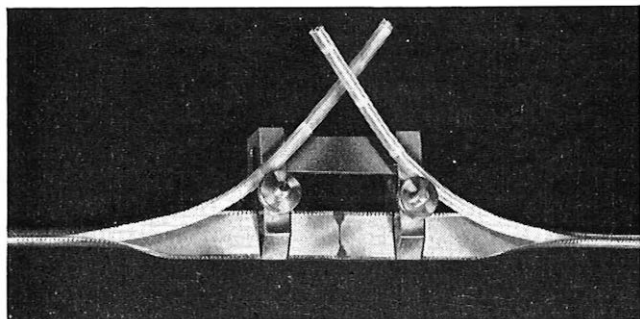

FIG. 3—BRAZED OUTER-CONDUCTOR HELD IN CLAMP

A pair of carbon-electrode brazing tongs are then connected to a socket marked TAPES on the brazing unit, and the two shapes are brazed together by placing the carbon electrodes centrally over the strip of silver solder and depressing the foot switch in the unit to apply the brazing current. The switch is kept operated until a deep-red glow appears in the tapes on both sides of the electrodes. When this occurs the brazing operation is complete. It is important to ensure that the brazing current is disconnected before removing the tongs, otherwise an arc will be formed as the carbon electrodes are opened, and this may burn the jointed copper tape.

Brazing the Centre Conductors. In order to braze the centre conductors together, the ends are laid side-by-side over the jointed outer-conductor tape, and at the centre of the joint the conductors are nicked by cutting squarely through the polythene insulation until the knife makes contact with the wires. The insulation is cut through at points $\frac{3}{8}$ in. from the nick marks, but this time care is taken not to nick the wires. The unwanted polythene insulation is removed by withdrawing it over the ends of the wires. The centre-conductor wires are cut to length at the nick marks by means of a pair of side-cutting pliers that have been specially ground to give the wires clean, square ends. A small piece of 2-in. wide insulating paper is fixed over the jointed outer-

conductor tape to prevent accidental contact with the jaws of the wire-brazing tool during the centre-conductor brazing operation.

The centre-conductor wires are positioned centrally in the jaws of the wire-brazing tool, and the clamping screws are tightened so that when the jaws are open the ends of the conductors are $\frac{1}{8}$ in. apart. When the jaws are closed the ends of the wires should butt squarely and the wires should be in alignment in both the horizontal and vertical planes. A narrow strip of 0.005 in. thick silver solder is placed between the ends of the wires, and the handles of the brazing tool are squeezed gently to hold the solder firmly in position. The foot switch of the brazing unit is depressed until a deep-red glow builds up from the junction of the wires and it is observed that the solder has fused the wires together (Fig. 4). The brazed joint is then visually examined, and any roughness due to surplus solder is removed with a strip of fine glass-cloth.

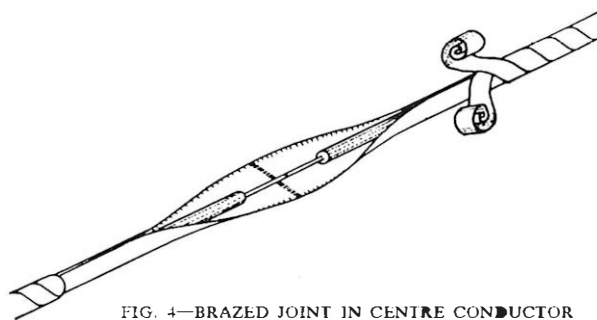

FIG. 4—BRAZED JOINT IN CENTRE CONDUCTOR

The unwanted polythene insulation removed to facilitate brazing the centre-conductor wires is replaced by insulation from a surplus piece of coaxial pair. After the polythene has been cut to length, it is split longitudinally through half its section and then pressed over the centre-conductor wire. The insulation is placed so that the split does not coincide exactly with the seam of the outer conductor when it is reformed.

Restoration of Outer Conductor. To restore the outer conductor tape to its tube formation, the tape is partially reformed, using the preforming tool. To complete the operation, a tube-reforming die is placed over the outer conductor close to the steel tapes on the up side of the joint, the end of the die having the smaller diameter being adjacent to the steel tapes (Fig. 5). The die is passed over the outer conductor as far as the steel tapes on the down side of the joint. The die is then reversed and passed over the conductor in the opposite direction. The operation is repeated until the outer conductor is evenly reformed.

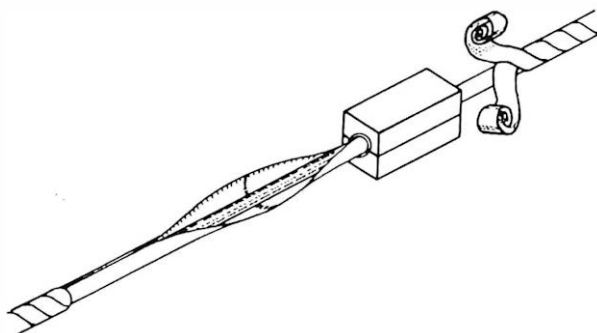

FIG. 5—RESTORATION OF OUTER CONDUCTOR

Restoration of Steel Tapes. The two steel tapes coiled on the up side of the joint are restored by lapping them tightly over the reformed outer conductor and securing their ends by a lapping of adhesive brown-paper tape. By lapping the steel tapes tightly, the edges of the reformed outer conductor are drawn close together.

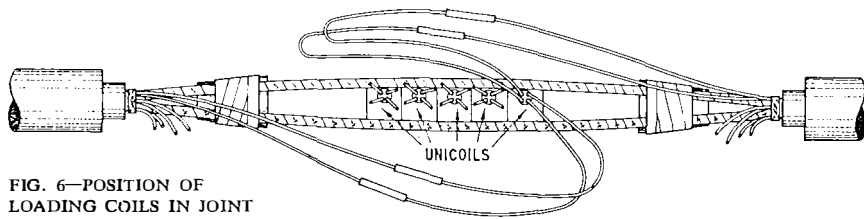

FIG. 6—POSITION OF LOADING COILS IN JOINT

Completion of Coaxial-Pair Joint. The jointing of the coaxial pair is completed by relapping the paper tapes tightly over the steel tapes and securing them with adhesive brown-paper tape.

Jointing the Paper-Insulated Pairs

The paper-insulated pairs are jointed by means of the crank-handle twist and soldered joint, and insulated with paper sleeves in the normal way.

Within-Joint Loading

If within-joint loading is specified, ferrite-type uncoils are installed in the joint between the coaxial pairs (Fig. 6). It is important that the uncoil tails should not be shortened; when the joint is being dried the uncoils can then be removed to a safe position away from the source of heat.

Sheath Closure

The jointing gap in the sheath is closed by means of a lead sleeve which is protected with a tape applied as a helix and made to extend over the polythene or hessian protective sheath. In order to prevent excessive heat due to the plumbing operations necessary with a lead sleeve from reaching and damaging the polythene insulation of the coaxial pairs, a short lead collar is interposed, at each end of the sleeve, between sleeve and cable sheath, if the cable has insufficient layer pairs, or none, to act as a heat barrier. The collar is first plumbed to the sheath and then the sleeve is plumbed to the collar. Less heat is produced in the sheath-to-collar wipe than would be produced if the sleeve is plumbed direct to the sheath. Furthermore, a considerable proportion of the heat in the sleeve-to-collar wipe is dissipated by the collar before it reaches the cable sheath.

CONCLUSIONS

It is found that most jointers quickly adapt themselves to the use of the brazing techniques, but there are a few who find difficulty in co-ordinating the operation of the

foot-switch with the hand-operated tools. In badly laid out or congested manholes it sometimes happens that a jointer cannot place the foot-switch where he can properly control it. He may then, for example, get his mate to operate the switch for him, on word of command. Such problems are inevitable with any new method, especially in the complexity of cable-jointing work, but it is undesirable to allow them to continue. Changes are being made in the brazing equipment to overcome such difficulties, firstly by spring loading the jaws of the wire-brazing tool, and then by replacing the foot-switch by a heavy-duty contactor operated by microswitches in the handles of the hand-brazing tools. In

order to make the technique of brazing available to jointers as quickly as possible, the brazing unit was designed for use with the jointers' 24-volt d.c. lighting sets. The brazing current can however be better controlled with equipment designed for use on a.c. power supplies, and, with the trend towards the replacement of hand tools by a.c. power tools for general field work, the opportunity to make a.c. brazing equipment economically available should not be long delayed.

APPENDIX

Sizes of 174A-Type Small-Diameter Coaxial Cable

Coaxial Pairs (174A-Type)	Numbers of Pairs in Cable		
	Interstice Pairs		Layer Pairs (20 lb/mile P.C.Q.T.)
	10 lb/mile P.C.Q.	10 lb/mile P.C.T.	
1	—	—	—
2	4	—	—
2	4	—	28
2	4	—	68
2	4	—	120
2	4	—	184
2	4	—	260
2	4	—	348
2	4	—	448
4	—	5	—
4	—	5	32
4	—	5	76
4	—	5	132
4	—	5	200
4	—	5	280
4	—	5	372
4	—	5	476
6	—	7	—
6	—	7	38
6	—	7	88
6	—	7	150
6	—	7	224
6	—	7	310
6	—	7	408
8	—	10	—
8	—	10	44
8	—	10	100
8	—	10	168
8	—	10	248
8	—	10	340
8	—	10	444

P.C.Q.—Paper-core quad. P.C.T.—Paper-core twin. P.C.Q.T.—Paper-core quad trunk.

Notes and Comments

Birthday Honours

The Board of Editors offers congratulations to the following engineers honoured by Her Majesty the Queen in the Birthday Honours List:

Belfast Telephone Area	M. W. King	..	Technical Officer	..	British Empire Medal
Factories Department	D. Blanche	..	Assistant Telephone Mechanic	..	British Empire Medal
Long Distance Area, London Telecommunications Region	B. H. Moore	..	Area Engineer	..	Member of the Most Excellent Order of the British Empire
North Area, London Telecommunications Region	C. C. Lowe	..	Technical Officer	..	British Empire Medal
Northern Ireland Directorate	E. G. Lloyd	..	Executive Engineer	..	Member of the Most Excellent Order of the British Empire
Scotland West Telephone Area	W. Robb	..	Technical Officer	..	British Empire Medal

Special Commendations

The Board notes with pleasure that the Postmaster-General has personally commended the following engineers:

Mr. J. A. E. Symes, Technician Class IIA, South West Telephone Area, London Telecommunications Region, to whom the Royal Humane Society has awarded its Testimonial on Parchment for rescuing a five-year-old boy from the River Thames at Chertsey on 27 August 1963.

Mr. E. C. Brice, Assistant Engineer, Dorchester Radio Station, to whom the Royal Humane Society has awarded its Testimonial on Parchment for his attempted rescue of a man from the sea at Mevagissey Bay, Cornwall, on 19 September 1963.

Board of Editors

The Council of the Institution has appointed Mr. E. Hoare a member of the Board of Editors in place of Mr. D. J. Harris, who recently completed his term of office as a member of Council.

Supplement and Model Answer Books

Students studying for City and Guilds of London Institute examinations in telecommunications are reminded that the Supplement to the Journal includes model answers to examination questions set in all the subjects of the Telecommunication Technicians' Course. Back numbers of the Journal are available in limited quantities only and students are urged to place a regular

order for the Journal to ensure that they keep informed of current developments in telecommunications and receive all copies of the Supplement.

Books of model answers are available for some telecommunication subjects and details of these are given at the end of each Supplement.

Correction

It is regretted that an error occurred in the article by Dr. R. A. Brockbank entitled "Twenty-One Years of Submarine Repeaters" (Vol. 57, p. 46, Apr. 1964). The article incorrectly states that the length of the COMPAC cable is 8,700 nautical miles: the correct cable length of COMPAC as laid is 8,150 nautical miles.

Book Review

"American Miniature and Microminiature Electronic Assemblies, Data Annual 1963-64." Edited by G. W. A. Dummer, M.B.E., M.I.E.E., Sen.Mem.I.R.E., M.Brit.I.R.E., and J. Mackenzie Robertson. Pergamon Press, Ltd. xii + 359 pp. 105s.

This substantial volume aims "at presenting in concise form, a wide range of technical information and practical applications data on representative small-sized assemblies currently available in the United States." Most of the firms in this field are American, and the book should be effective in encouraging the use of American equipment of this type. A few of the firms quoted have factories in Great Britain.

Up to the present, micro-electronics and packaged assemblies have been little used in Post Office equipment, though some people may have seen information circulated by the Post Office Research Station (1962) on a 4-stage audio-frequency amplifier made by Centralab. This particular packaged amplifier is described on pp. 220-221 of the volume under review. However, not all the types described are as small as this.

The book includes modules with both logic and linear circuits. Broadly speaking up to page 217 modules and assembly techniques (including parts for fluid amplifiers) are described; from page 217 to page 255 complete amplifiers, choppers, flip-flops are shown; and from page 255 to page 359 complete equipments such as small computers, counters, read-outs, memory stores, band-pass filters, oscillators, signal generators, timers and time-delay modules, pulse generators, and servo amplifiers are covered. However, since the classification is principally by manufacturers the above arrangement is not rigidly followed.

Examples of most of the successful techniques occur in this extensive collection, e.g. printed wiring, fired-paint wiring and resistors, flexible-card circuits, ceramic-wafer components, solid-state modules and circuits, thin-film circuits, optical fabrication techniques on glass, and formed, embedded, and flush circuits.

It is to be hoped that a similar volume covering British equipment of the same type will soon be available.

A.A.N.

Institution of Post Office Electrical Engineers

Institution Field Medal Awards, 1962-63 Session

In addition to the Institution Senior and Junior silver and bronze medals, up to three bronze medals, the Field Medals, are awarded annually for the best papers read at meetings of the Institution on field subjects primarily of Regional interest.

Field Medals were awarded to the following authors for papers read during the 1962-63 session:

F. B. Wilcher, Bristol (South Western Region). "The Effect of Developments on Engineering Control Costs."

J. C. Hay, Edinburgh (Scotland). "Road Works."

K. Grainger, Leeds (North Eastern Region). "Data Transmission."

The Council of the Institution is indebted to Mr. J. W. Freebody, Chairman of the Papers Selection Committee of Council, for the following précis of the medal-winning papers:

Mr. Wilcher's paper entitled "The Effect of Developments on Engineering Control Costs" was, appropriately, first presented at the beginning of the 1963 National Productivity Year. The paper critically reviews the existing Post Office engineering cost control systems in the light of developments in the engineering and administrative fields, and suggests there is considerable scope for improvements and a reduction of costs.

As a key note to the style of the paper, he quotes this message given by H.R.H. Prince Philip when inaugurating the National Productivity Year.

"I rather hope that the National Productivity Year will give the nation a bad conscience, that unhappy feeling that it isn't doing as well as it might. Then perhaps we could all get down to finding ways in which things might be improved—and this covers everything from the daily work of individuals right through the organization of industries and Government departments. In fact, it means work study on a national scale."

The paper deals with many aspects of the present engineering cost control systems, and concludes that they require radical overhaul to make them more useful to the engineer and to provide the administration with the essential accounting information which is needed to fix charges and rentals. He argues that there are many obsolete and time-wasting procedures in use which should be removed and also that the performance-rating method of gauging efficiency and output is wrong, as it tends to produce high costs. A good performance rating can be obtained by doing more work on site than is necessary to provide a satisfactory service, and there is evidence that this is happening to-day.

He also argues that there is too much delay and resistance by both controlling engineers and the administration to the introduction of new ideas, methods, and materials aimed at reducing costs. He roundly condemns the attitude of mind which accepts without question long-established practices when just a little thought will show that developments have made them obsolete.

He concludes that output of engineering work could be increased by 20 per cent by improving organization so that more time is available for effective work. This is a management responsibility in which we must all play our part.

The paper by Mr. Hay on "Road Works" examines the effects of road-improvement schemes on the planning of Post Office cable and duct networks. The paper gives a short, but none the less admirable, review of many of the basic problems which the planning engineer has to take into account in order to safeguard Post Office interests.

The paper stresses that, although the Post Office is entitled to recover the cost of alterations to its plant under various Parliamentary Acts, there are considerable limitations. The legal aspect of road works is in many cases not clear, and it is certainly not true, as some people think,

that the Post Office can invariably recover its costs in full. On the contrary, in many cases it is only possible to recover from the Road Authority a small fraction of the outlay on the Post Office plant replaced. Furthermore, the Post Office may have to bear the cost of ducts laid in advance of the time when they would normally have been required.

The author emphasizes the need for Post Office staff to make sure that full advantage is taken of existing law to claim all that the Post Office is entitled to, otherwise the cost of the effect of road alterations on Post Office plant will fall increasingly on the telephone subscriber.

The risks and common causes of damage to Post Office plant are discussed, together with the subjects of temporary diversions and methods of temporary supports for cables at points where an underpass road is being constructed. The author argues that the introduction of subscriber trunk dialling has made the effect of damage to trunk cables much more severe, and points out that the loss of revenue from lost calls may well exceed the actual cost of repair of the cables concerned. Planning for maximum plant safety during road works is, therefore, essential.

The paper states that as a result of the much greater mechanization of methods employed in road works even major road and bridge projects are put out to tender without detailed plans, and the road engineer is allowed more latitude in carrying out the work and takes advantage of this. It is difficult for Post Office engineers to alter plans at short notice due to present estimating procedures, and the author suggests that Post Office methods for estimates, and plans, etc., require to be modernized to keep pace with the changed situation brought about by modern road-work techniques.

The paper entitled "Data Transmission" by Mr. Grainger forms an excellent introduction to a subject which will certainly become increasingly important to Post Office engineers. It defines what is meant by data transmission and explains the difference between analogue and digital systems and the relative merits. The paper thereafter concentrates on a discussion of digital data transmission, explains the relationship between signalling speed (i.e. bit rate) and bandwidth, and discusses the effects of amplitude and phase distortion.

Various modulation systems are considered in relation to existing telephone-transmission channels, with some discussion of the effects of noise and momentary interruptions on data-carrying circuits. In this connexion the value of redundancy coding is explained, and various methods of error detection and correction are described.

The problems of data transmission over telephone and telegraph circuits, including private wires and Telex, are described, and some information is given on the use of parallel bit transmission of data over telephone circuits as well as the more usual form of serial transmission of bits.

The paper is extremely well illustrated by a large number of excellent diagrams.

Result of Essay Competition, 1963-64

A prize of £6 6s. and an Institution Certificate have been awarded to the following competitor in respect of the essay named:

A. G. Hickson, Technical Officer, Northampton. "Is Your Journey Really Necessary?"

Prizes of £3 3s. each and Institution Certificates have been awarded to the following four competitors:

J. S. Lishman, Technical Officer, Slough. "Planning S.T.D. in an Empty Continent."

P. Moverley, Technical Officer, Cardiff. "Labour Relations in the Post Office Engineering Department."

G. D. Richardson, Technical Officer, Stamford. "A Theme on Thor."

D. W. J. Smith, Technician I, Bletchley. "Mechanical Aids—Their Evolution and Application to Modern Line Plant Practice."

Institution Certificates of Merit have been awarded to: D. E. Cahill, Technical Officer, Nottingham. "The Officer in Charge."

R. J. Waterhouse, Technical Officer, Stone. "Signalman to Civilian."

P. J. R. Evans, Technical Officer, Ramsgate. "Room for Improvement."

G. D. Cumming, Technical Officer, Belfast. "Psychology and the Post Office Engineer."

D. A. Elwood, Technical Officer, Truro. "Prelude in Plastics—A Critical Look at Some Recent Developments in External Telecommunication Cable Practice."

The Council of the Institution records its appreciation to Messrs. R. O. Boocock, E. Hoare and D. G. Jones, who kindly undertook to adjudicate upon the essays entered for the competition.

N.B.—Particulars of the next competition, entry for which closes on 31 December 1964, will be published later.

Increase in Annual Subscriptions

A ballot of the Corporate Members was not required on the Council's proposal, submitted to the Corporate Members, to increase the annual subscriptions to cover the increase in the cost of the Post Office Electrical Engineers' Journal and the general increase in the Institution's expenditure. The proposed change to Rule 13, Subscriptions, to cover the increase is now operative, starting 1 April 1964. The increased annual subscriptions are as follows:

Member £1 6s. (formerly £1 3s.)

Associate Member £1 3s. (formerly £1)

Affiliated Member £1 3s. (formerly £1)

Arrangements have been made with the Accountant-General's Department for the increased deduction from salary to be made without requiring fresh forms of consent to be signed by members.

The annual subscriptions of Corresponding Members (Non-Corporate Members) will also be increased from £1 3s. to £1 6s., starting 1 April 1964.

Retirement of Mr. L. R. Hargrave

Mr. L. R. Hargrave, Honorary Secretary of the South West Centre of the Institution, and an Executive Engineer, retired on 25 March 1964 after 41 years' Post Office service, all spent in Bristol.

The success of the Institution's activities depends on the enthusiasm and service of the local centre officers, and Mr. Hargrave was an outstanding example. He accepted the office of Honorary Local Secretary of the South West Centre in 1943 and held it for an unbroken 21 years until his retirement. The success of the South West Centre is due in no small part to Mr. Hargrave's tact, efficiency and hard work throughout his long service.

The Council of the Institution has great pleasure in recording its sincere thanks to Mr. Hargrave for his long and meritorious service, and expresses its warmest wishes for a long and happy retirement.

S. WELCH,
General Secretary.

Additions to the Library

Library requisition forms are available from Honorary Local Secretaries, from Associate Section Centre Secretaries and representatives, and from the Librarian, I.P.O.E.E., G.P.O., 2-12 Gresham Street, London, E.C.2.

2753 *Inventing the Future*. D. Gabor (Brit. 1963).

The author discusses the problems of nuclear weapons, over-population, and the age of plenty.

2754 *Science and Government*. Viscount Hailsham (Brit. 1963).

The first Minister of Science describes and discusses some of the problems to be solved by those responsible for the developing relationship between science and government.

2755 *Heat Engines for National Certificate Students*. F. Metcalfe (Brit. 1962).

Intended to meet the requirements of students taking the subject of heat engines in the Ordinary National Certificate course in mechanical engineering.

2756 *Physics for Engineers*. G. F. Lewin (Brit. 1963).

Aims to introduce the engineer in a reasoned manner to the basic concepts of physics, and to show how these are related to the more advanced theoretical work which he is likely to meet in engineering.

2757 *Spaceflight Today*. K. W. Gatland (Ed.) (Brit. 1963).

Covers a wide field and consists largely of material published in the magazine "Spaceflight."

2758 *Engine Repair for the Owner-Driver*. S. Abbey (Brit. 1963).

Money-saving methods of engine repair for the do-it-yourself owners.

2759 *On Thinking Statistically*. M. B. Brodie (Brit. 1963).

Based on a series of talks addressed to experienced managers attending the Administrative Staff College Course at Henley.

2760 *Cinematography for Amateurs*. J. H. Reyner (Brit. 1951).

A comprehensive guide.

2761 *Engine Noise; Analysis and Control*. C. H. Bradbury (Brit. 1963).

A concise exposition bridging the gap between school physics and the comprehensive treatise.

2762 *Heating and Hot-Water Services*. E. W. Shaw (Brit. 1963).

Deals with fundamental principles and their application; intended as a basic reference for practising engineers and as a text for students.

2764 *Essays in Electronics*. M. G. Scroggie (Brit. 1963).

Further thoughts by "Cathode Ray."

2765 *Introduction to Lasers and Masers*. A. Lytel (Amer. 1963).

Introduces the various devices used to produce microwave and light radiation. The background of microwave communication is covered thoroughly.

2766 *Audio and Acoustics*. G. A. Briggs and J. Moir (Brit. 1963).

A revision of some parts of the book Sound Reproduction

2767 *The Miracle of Life Sources*. H. Woltereck.

Examines the possibilities of life on other planets, describes what is known of cellular growth and structure, and traces the developing stream of life in all its forms.

2768 *Electrical Engineering*. G. E. Williams and B. J. Prigmore (Brit. 1963).

A comprehensive survey of principles and applications. Covers the electrical subjects in Pt. 1 and 2 of the I.E.E. examination, and part of Pt. 3; also Pt. 1 and much of Pt. 2 of the electrical course for the London B.Sc.(Eng.) degree.

2769 *Little Men in the Unseen World*. H. E. Duckworth (Brit. 1963).

A guide to atomic physics for the general reader.

W. D. FLORENCE,

Librarian.

Regional Notes

North Eastern Region

MODERNIZATION OF THE HUDDERSFIELD TELEPHONE SERVICE

On Saturday, 29 February 1964, the conversion of Huddersfield exchange from manual to automatic working took place. The new exchange, shown in the photograph, is



HUDDERSFIELD NEW AUTOMATIC TELEPHONE EXCHANGE

a group switching centre with subscriber trunk dialling (S.T.D.), having a multiple of 12,000 lines, and an auto-manual board of 26 ordinary positions and 10 enquiry positions. The change-over operation was completed in just under four minutes. The sequence of events leading up to this operation is described, together with the details of the Huddersfield charging group, before and after the transfer.

Before 8 February 1964, Huddersfield old manual exchange, which was a C.B.1 exchange of 10,000-line multiple, was the only exchange serving Huddersfield itself. The exchanges at High Flatts, Marsden, Meltham, Skelmanthorpe, Kirkburton and Honley were all working with Halifax as the temporary parent-exchange, whilst Slaithwaite was working with Milnsbridge as temporary parent. All these temporary measures had been working for some time to provide relief to Huddersfield old exchange.

On Saturday, 8 February, Huddersfield new automatic telephone exchange (A.T.E.), the auto-manual board, and the new maintenance control, were opened to a limited extent when the parent routes from the unit automatic exchanges at High Flatts, Marsden, Meltham and Skelmanthorpe were transferred from Halifax to Huddersfield. At the same time, subscribers on these four exchanges were given the same dialling facilities via Huddersfield A.T.E. that they had previously had, using a temporary tandem switching-unit installed in Halifax A.T.E.

On Monday, 10 February, the connexion of the 197 Huddersfield subscribers' pay-on-answer coin-boxes to the new A.T.E. commenced, and was completed in just over a week. On Monday, 17 February, the fitting of the 115 Huddersfield public pay-on-answer coin-boxes started, and was finished by 22 February. As coin-boxes were fitted, they were given S.T.D. and full dialling facilities except access to Huddersfield subscribers, who, until 29 February, were obtained by dialling 100, calls being completed by the auto-manual operators using circuits provided temporarily to the old manual exchange.

Similarly, during this period, before the full opening of the new exchange, access to the new coin-boxes was obtained by operators at the old exchange using circuits provided temporarily to the new exchange.

The final conversion just before 8 a.m. on Saturday, 29 February, involved the following operations:

(a) All Huddersfield ordinary subscribers, a total of about 8,800, were transferred. Of these, 7,700 were routed via break-jacks at the new exchange, and thence via tie-cables to the old exchange. They were isolated from the automatic equipment by fitting locking wedges into the test jacks on the new exchange main distribution frame (M.D.F.). At transfer, the subscribers were first isolated from the old exchange by inserting pegs into the break-jacks, and then connected to the automatic equipment by withdrawing the locking wedges from the test jacks. The remaining 1,100 subscribers, except for the Head Post Office telephones, were teed in an external cabinet. At transfer, they were first isolated from the old exchange by withdrawing the heat coils on the old exchange M.D.F., or by inserting the wedges which had already been fitted in the protector test springs of the old exchange M.D.F. These subscribers, also, were then connected to the automatic equipment by withdrawing the locking wedges from the test jacks on the new exchange M.D.F. The Head Post Office telephones were teed in the Head Post Office. The tees were first disconnected, and the lines then connected to the automatic exchange in the same way as the other subscribers.

(b) All the remaining trunks and junctions on the routes to the 34 distant exchanges were provided. Pairs for these circuits were obtained from junctions working to the old exchange up to conversion. They were transferred to the new exchange by the operation of change-over arrangements at that exchange and at each outstation. Changed-number announcement equipment with a special recording was connected from Huddersfield where necessary. The new repeater station at Huddersfield had been working for several weeks, and the permanent arrangements for all repeated circuits had been completed well before the transfer and were not affected by the transfer.

(c) Honley was connected to Huddersfield as a group-selector satellite exchange, and so lost its separate identity.

(d) Honley and Kirkburton exchanges were reparented from Halifax exchange, and Slaithwaite exchange from Milnsbridge exchange, to Huddersfield. Honley coin-boxes remained parented on Halifax exchange, and Slaithwaite coin-boxes remained parented on Milnsbridge exchange until the pay-on-answer coin-boxes were fitted at Honley and Slaithwaite during the first two weeks of March.

(e) S.T.D. was introduced to Huddersfield, Honley and Slaithwaite ordinary subscribers, and to Kirkburton ordinary and coin-box subscribers. As explained above, Huddersfield coin-box subscribers were given S.T.D. in the three weeks before conversion, and at conversion they were also given dialling access to the Huddersfield ordinary subscribers. As the Honley and Slaithwaite pay-on-answer coin-boxes were fitted during the two weeks following the conversion, they were also given S.T.D. and reparented on to Huddersfield exchange. Kirkburton pay-on-answer coin-boxes have been fitted since April 1963 without S.T.D.

(f) Dialling facilities between the Huddersfield charging group and its adjacent charging groups were considerably extended. This involved extensive re-issue of code cards and visits to kiosks. Some of the kiosk visits had to be made as quickly as possible after transfer, as other code changes were taking place in Bradford at the same time. Other kiosk visits were made during the following week.

V.C. and L.J.D.B.

Midland Region

TRIAL OF ABOVE-GROUND JOINTING POSTS

Recent experience tends to suggest that there is a real advantage in taking several underground service leads from individual houses to a common jointing point, as this re-

duces the total number of joints made and reduces fault liability. Cost investigations revealed that groups of up to 10 houses on one side of a road, or 20 if a road crossing is provided, could be served economically in this way, as the cost of excavating for, and making, small joints outside each house exceeds the cost of the extra cable provided and laid. The number of leads which can be accommodated in normal underground joints is, however, limited, and consideration was given to the development of a joint which could be made above-ground. Provided that it could be of good appearance, it was expected that it would have advantages over normal below-ground jointing methods, particularly regarding ease of installation, improved accessibility, and elimination of the passage of water into and between cables.

An item was developed, in consultation with the External Plant and Protection Branch, Engineering Department, and it consists, essentially, of a 4 ft length of 3 in. \times 1½ in. galvanized rolled-steel channel-section which is set vertically in the ground for the greater part of its length and fitted with an anodized cast-aluminium cover. The cover is secured to a face-plate at the ground line by means of a triangular-headed bolt. Cables can be jointed in the channel section, using silicone-grease-filled sleeves. A post with a 9 in. cover will accommodate up to 20 pairs, whereas one with a 16 in. cover can take, in addition to the service leads, either a "looped-through" cable of up to 100 pairs or a 50-pair cable jointed to smaller ones.

The first post has now been installed at Aldridge, Staffordshire, where a group of eight houses is served from a 50-pair cable, which is looped through the post. A 2-pair cable has been provided to each house through a pipe which had been laid by the builder from the footway. The second pair in each cable was connected to an earth bar, which was provided in the post for shared-service purposes, and the pair will be available, if required, for a second line or an external extension. On this particular estate, use has

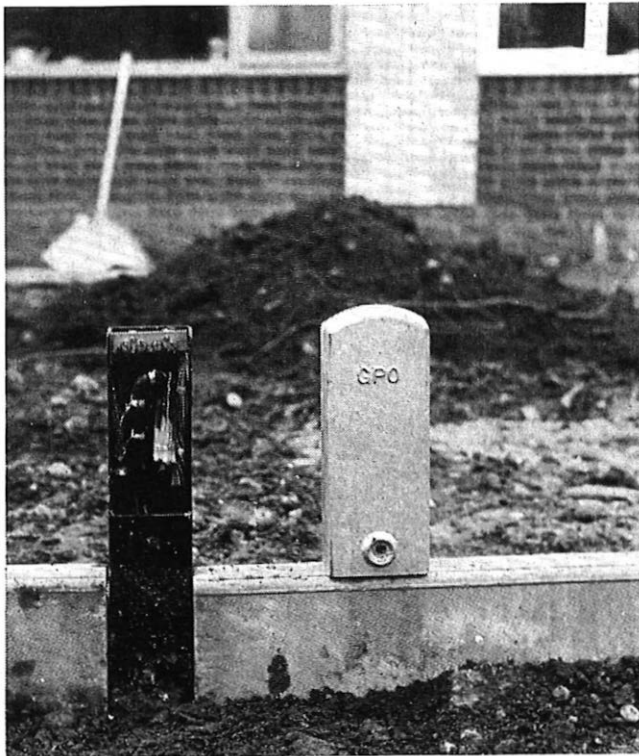

ABOVE-GROUND JOINTING POST

been made of specially-designed 4-wire, 10 lb/mile cable with solid p.v.c. insulant, having four longitudinal grooves to facilitate separation. This may prove more robust than normal polythene cable and prevent passage of water, though it is more bulky to joint and to terminate.

The jointing arrangements in the post are shown in the photograph. Use of the posts has been planned in a number of estates, and the developers have agreed to their provision.

R.G.T. and L.C.P.

Scotland

LIGHTNING DAMAGE AT GREEN LOWTHER

A hard time was certainly in store for the underground maintenance staff when a lightning discharge damaged the Green Lowther spur of the Carlisle-Glasgow No. 3 cable on 30 January 1964. The damage occurred although all the standard precautions against lightning strikes had been taken, including the provision of polythene-sheathed cable at the summit of Green Lowther, and the insertion of isolating transformers in every cable pair. No one could have worked harder than did the gang, jointers and precision testers who laboured making repairs in conditions which varied from mild spring sunshine to sub-Arctic blizzards, the latter predominating.

Initial tests showed immediately the extent of the damage; there was no continuity on any wire of the routes between Green Lowther radio station and Leadhills U.A.X., Beattock repeater station, and Lanark exchange. In addition, most pairs were earthing, short-circuited or in contact with another pair. Consequently, early fault-location was a hit-and-miss procedure. For example, an earth fault measuring three miles away might, in fact, only be ¼ mile from the testing point because the wire would be welded to another at a disconnected joint, and would double backwards and forwards before eventually earthing. Disconnexion tests, which were the only type it was possible to carry out to start with, were unreliable, but it didn't really matter as faults of one kind or another were apparent and cleared in every joint that was opened.

By 7 February, sufficient pairs had been cleared to Leadhills U.A.X. to enable the extended-alarm system to operate. The men were withdrawn for the week-end, both to clear a carrier-cable fault at Mossfennan, and to obtain a rest from the arduous conditions. On 12 February, a fresh start was made, and by 27 February there were only three pairs still faulty. As ample spares existed, these faults were dealt with at a later date when conditions were more favourable.

Some idea of the severity of the conditions experienced by the men on Green Lowther, which rises to a height of 2,400 ft, may be gained from the following details. One vehicle had halted half-way up the hill for a short time and then been driven to the summit where it was found that, despite the anti-freeze, the water in the lower radiator hose had frozen and the water pump was damaged. The maintenance gang was employed not only to lay cable and excavate buried joints, but also to erect jointers' tents when high winds made it impossible for the jointer and his mate to do this without assistance; during one evening when they were doing this, both a wind velocity of 70 m.p.h. and a temperature of 7°F below freezing point were recorded.

A summary of the work done up to 27 February is as follows:

- (a) Ten faulty joints had to be opened and re-made.
- (b) Three loading pots were opened and faulty uni-coils cut out.
- (c) Three hundred and ninety yards of cable (in three lengths) were laid over-ground.
- (d) Two lengths of cable in duct were renewed.

G.C.

Associate Section Notes

Bournemouth Centre

Our program of visits was completed by a third visit to the B.B.C. television centre, in January, and a second visit to Mullard, Ltd., Southampton, in February. Both trips were instructive and enjoyable.

The annual general meeting was held on 7 April, and was not well attended considering that only 12 of our 95 members came along. During the proceedings the following officers were elected: *Chairman*: Mr. L. J. Taylor; *Secretary*: Mr. D. P. Cosh; *Assistant Secretary*: Mr. A. E. A. Barwell; *Financial Secretary*: Mr. W. G. Limburn; *Committee*: Messrs. H. J. Goodwin, H. E. Haddon, G. Mouat, and D. Woodley.

The Chairman thanked Mr. Barwell for his enthusiasm and efforts of the past two years.

The meeting ended with two films: one, called "Network," from the film library of A.E.I., Ltd., and the other a Home Office production named "Exodus."

D.P.C.

Plymouth Centre

The first meeting of the 1963-64 session was held on 16 October. A paper, entitled "S.T.D. in the Non-Director Area," was presented by Mr. B. G. Woods, Telephone Exchange Standards and Maintenance Branch, Engineering Department. His excellent paper was illustrated by a number of coloured slides.

In November, Mr. C. S. A. Smith, Research Branch, Engineering Department, gave a paper on "Transistors and Their Applications"; a lively discussion followed. To complete a very enjoyable evening, Mr. Smith gave a short introductory talk on Time Assignment Speech Interpolation (T.A.S.I.) followed by a test tape-recording.

"An Introduction to Computers," by Mr. B. G. Sweet, was the subject of our January meeting. Three computers were used to illustrate the lecture, one of which had been constructed in the Plymouth College of Technology, where Mr. Sweet is a full-time lecturer.

A visit to the Plymouth electricity generating station was made in February. This visit was well attended and proved most enjoyable and informative.

Members were very pleased to accept an invitation by Mullard, Ltd., to attend an illustrated talk on colour television and v.h.f. broadcasting on 22 April. This visit was closely followed, on 28 April, by the presentation by Messrs. B. J. Woollett, South Western Region, and L. B. Handley, Birmingham Area, of a very interesting paper on the Swedish telephone service, written following an exchange visit of one month to Stockholm.

S.W.P.

Cornwall Centre

The winter session opened with an informal talk on "The Development and Future of Materials used in Post Office work," by Mr. C. E. Richards, ex-Deputy Director of Research, Engineering Department. The talk was well received by all present as materials are often used, and sometimes criticised, with little thought of the extensive processing and testing which has to take place before they can be issued for general use.

Mr. C. S. A. Smith, Research Branch, Engineering Department, gave, for the November meeting, a paper entitled "Transistors and Their Applications," and as transistors are being employed more and more widely in Post Office equipment the meeting was well attended. Mr. Smith illustrated his paper with slides and various pieces of new transistor-type equipment.

The centre was permitted to hold the February meeting in the new telephone-engineering centre at Truro, where Mr. G. W. Willis, Elliott Bros., Ltd., gave a talk on "Digital Computers," covering from the early pioneer days of computing machines to the elaborate and complicated apparatus in use today.

The annual dinner and dance was held at the Great Western Hotel, Newquay, on 6 March. A record number of members, wives and guests attended, and the function was thoroughly enjoyed by everyone. A presentation was made to Mr. A. R. Brown in appreciation of his untiring efforts as founder member and Secretary of the Centre who, due to his recent promotion to Assistant Engineer, will not be eligible for re-election to Secretary this year.

D.J.G.C.

Middlesbrough Centre

A thoroughly interesting and successful season has now drawn to its close. During the year our Chairman, Mr. Norman Williams, was promoted to the Engineering Department, and Mr. Eddie Sparks now officiates in that capacity. Membership is still increasing steadily, and we anticipate an equally successful season next year.

There have been two noteworthy achievements during the season. The first is the award of 1st prize and the North Eastern Region Associate Section Journal Shield to Mr. Dave Watkins for his article "The Search for Minerals," published recently. The Journal Shield was presented to Mr. Watkins by Lt.-Col. J. Baines, O.B.E., Chief Regional Engineer, North Eastern Region, on the evening of Tuesday, 4 February at a social evening held in The Grove Hotel, Middlesbrough. Col. Baines was accompanied by Col. J. R. Sutcliffe, O.B.E., Telephone Manager, Middlesbrough Area, and Mr. E. Speechley, Area Engineer. Other welcome visitors from Regional Headquarters were Mr. A. K. Robinson and Mr. E. King. Amongst the 50 or so people present were several Senior Section members. The meeting was reported in the Evening Gazette the following evening.

Our second success in the Associate Section Paper Awards for 1962-63 was that of Mr. C. E. Cox. The I.P.O.E.E. Council awarded a prize of £4 4s and an Institute Certificate to Clive, who is now a member of the Darlington Centre, for an essay which he submitted, based on a paper given to the Middlesbrough Centre during 1962, entitled "The Earth's Natural Satellite." Clive Cox has developed his interest in astronomy to the extent of building several telescopes. With his latest, a 12 in., 7 ft 6 in. long telescope, he has taken a number of excellent photographs of the surface of the moon.

D.C.

Sheffield Centre

The 1963-64 program continued with a lecture, entitled "Microwave Techniques," by Mr. N. A. Elkins, Inland Radio Planning and Provision Branch, Engineering Department. With the help of slides and models, Mr. Elkins delivered a very interesting lecture on a subject which is relatively new to many in this Area. An insight into the future of communications as a result of the rapid development of microwave links proved most enlightening.

On 1 April, 37 members of the Centre toured the Ford Motor Works at Halewood, Liverpool. Although opinions differed regarding the materials used for particular components, and the methods of assembly, all agreed that the layout of the plant was magnificent. The machines and tools used at the plant were of as great an interest as was the actual assembly of the cars produced.

At the time of writing these notes, our Area Liaison Officer, Mr. T. C. R. Harrison, approaches retirement. Mr. Harrison has been in Sheffield since 1937, and has always taken an active interest in the work of the Centre. It is with great regret that we have to say goodbye to him after so many years and we shall miss his co-operation, assistance and advice. As Secretary of the Centre, I should like to express on behalf of all the members in Sheffield, our sincere appreciation for his invaluable help over the years, and to wish both him and Mrs. Harrison a long and happy retirement.

D.A.

Bletchley Centre

Attendance at meetings in the latter part of the winter program waned, and committee members are feeling rather concerned at this trend.

The winter session continued with a talk, in January, by Mr. H. E. Pearson, Space Communication Systems Branch, Engineering Department, on the construction and planning of the experimental satellite ground station at Goonhilly Downs. The problems of choosing the site were dealt with before illustrating the manner in which the large tracking bowl and its mechanism were constructed. This was followed, in February, by Mr. A. F. Parr, from the special roads division of the Ministry of Transport, who first explained the duties of the division before discussing the costs of a motorway project. He then covered the formalities of planning a highway route, illustrating this with plans of the M6 motorway. The talk finished with coloured slides of architecture used in the construction of motorways. Members were amazed at the enormous problems and obstacles involved in the planning of such projects.

The program finished, in April, with a talk on the speaking clock by Messrs. J. H. Gee and R. R. Walker, Telephone Exchange Standards and Maintenance Branch, and Research Branch, Engineering Department, respectively.

A.J.H.

Lancaster Centre

The annual general meeting was held on Tuesday, 2 April, and the officers and committee members for the previous year were returned to office.

On 19 June 1963, 17 members visited Thwaites Star Brewery, Blackburn. Also, 15 members visited Mullard, Ltd., at Padiham, where the construction and testing of various types of television tube is carried out. We were shown the welding of the screed to the neck of the tube, the phosphur coating being applied to the screen, the fitting of the grids, the vacuum plant, and finally the testing of the finished product.

Our first lecture of the season, entitled "The Evolution of Lancaster Exchange," was given by Mr. G. Maynard, a local member. Thirty members and visitors were present and it was considered to be one of the most interesting and informative talks we have had.

In November, two visits were made to Ford Motors at Halewood. Fifty-six members, in all, saw the Halewood plant, from the huge presses producing car bodies, through the assembly and paint shops, to the finished product being tested for gear changing, etc., on a roller bed.

The winter program consisted of three lectures, which were as follows:

"The Skeleton in the Cupboard—How Sound is Our Approach to Cable Maintenance," by Mr. A. F. G. Allan, Main Lines Development and Maintenance Branch, Engineering Department.

"Fault Localization in Long Submarine Cables," by Dr. P. R. Bray, Test and Inspection Branch, Engineering Department, and

"Subscribers' Maintenance Problems," by Mr. A. A. George, from Leeds Area.

These lectures were attended, with great enthusiasm, by about a third of the members, and involved many interesting discussions.

The 1963-64 session has been a success, with an increase in membership from 60 to 90 members. It is hoped, however, that there will be an increase in the number attending meetings in the coming season.

C.W.

Canterbury Centre

The Centre now has a membership of approximately 210 members. The winter program included the following:

11 December: A talk, "The Museum Tower," given by Mr. Newman.

29 January: Mr. S. T. E. Kent, Area Engineer, Canter-

bury Area, gave an interesting and enlightening talk on "Work Study."

10 and 17 March: Visits were made to C.A.V. of Rochester, who specialize in electrical and fuel injection equipment.

24 March: A talk on "Space Communication Systems" by Mr. D. Wray, Space Communication Systems Branch, Engineering Department.

B.C.

Ipswich Centre

We ended our summer 1963 program in September with a visit to Rotterdam, Holland, as guests for the day of the Dutch P. and T. Department. Conducted tours round Rotterdam telephone exchange, and afterwards around the harbour and docks by pleasure steamer, were thoroughly enjoyed by all.

Our winter session commenced on 17 October with a paper on "Repeater Stations" given by a local member, Mr. F. Kerry. In February, a paper on "Electronic Exchanges," by Mr. D. L. Benson, Telephone Electronic Exchange Systems Development Branch, Engineering Department, gave us a glimpse into the future, and was well received.

On Saturday, 7 March, we held our annual dinner and dance at the Regal Restaurant, Felixstowe. This was attended by Mr. Hamilton, Telephone Manager, Mr. Radcliffe, Area Engineer, Mr. Sanders, Regional Liaison Officer, and some 150 guests.

The winter program has also contained talks about Gipsies, about the Post Office and the television service, and about new coaxial systems.

Future plans include a three-day visit to the Volkswagen factories at Wolfsburg and Hanover in Germany.

K.R.C.

Aberdeen Centre

The first meeting of 1964 was held in Inverness on 15 January. Mr. R. J. Hines, Chief Regional Engineer, Scotland, presented Institute Certificates to Mr. J. C. Hines, Inverness, for his essay "Some Aspects of Human Relationships in the Engineering Department," and to Mr. A. Christie, Thurso, for his essay "On Designing a Circuit." Two excellent talks followed, one by Mr. A. MacKenzie entitled "The History of Television," and the other, by Mr. F. Downie, entitled "The Cathode-Ray Oscilloscope." Both talks were well illustrated by film strips and were very well received by an audience of 37 members and guests.

In Aberdeen on 23 January, an excellent lecture was given by Dr. A. W. M. Coombes, Research Branch, Engineering Department, entitled "Character Recognition." The subject was one dealing with the problem of recognizing the characters on an addressed letter with a machine. With the aid of film slides of a random sample of addressed envelopes, Dr. Coombes explained the difficulties a machine would face. The multitude of variations in character, shape and address position was staggering. During his resumé of American machines, Dr. Coombes broached such subjects as template matching, feature matching, and the human brain cells. He rounded off his lecture by a demonstration on a small machine, which was taught to recognize characters after being put through a number of learning cycles. The 33 members and guests enjoyed a most informative evening.

Two meetings were held in February, one in Inverness and the other in Aberdeen; on both occasions Mr. J. Brown was the speaker. Mr. Brown's subject was "Hydro-Electric Power in the Highlands," and was well illustrated with coloured film slides showing equipment (both Post Office and Hydro-Electric Board), typical terrain, and a number of the power stations. The hazards encountered, and the various measures taken to ensure the safety of personnel and the protection of equipment and cables was well explained. At both meetings, considerable interest was aroused

by Mr. Brown's talk, and the many questions put to him were ably answered. The Aberdeen Centre was honoured by the presence of Mr. R. J. Hines, Chief Regional Engineer, who presented Institute Certificates to Mr. G. D. Adam for his paper "An Introduction to Computers and Programming," and to Mr. A. M. Duff for his paper "Program Circuits."

The theme of our March meeting was Hobbies—in particular, those connected with radio. "Amateur Radio" was presented by Mr. J. McColl, who gave a description of a typical "ham" station and also explained the necessary qualifications required before a licence was granted. He described fully the frequency bands allocated to amateurs, and the various details of transmitters, receivers, aerials, oscillators and measuring instruments. Our second speaker was Mr. G. Harvey, who presented "Radio-Control Models." He explained that the radio part was really secondary to the building of the models, two of which he had on display. He then explained "lock-on" and "progressive" controls, frequency bands used, and some of his experiences with one of his models. A great deal of questions were asked and the 30 members and guests present enjoyed an interesting evening.

D.W. and G.D.A.

Dundee Centre

Our 1963-64 session ended on 4 April with a visit to Craigowl Hill for Mr. G. Duff's lecture. Attendance at all meetings and visits has been excellent, indicating a renewed enthusiasm amongst our members.

The annual general meeting was held at the end of April.

R.T.L.

Edinburgh Centre

The first visit of the 1963-64 session was to South Queensferry in July when a party of our members were shown over the Forth rail-bridge. This was a very successful outing from the points of both interest and weather conditions, the photographers in the group taking particular advantage.

In September, Mr. D. M. Plenderleith, from Edinburgh Area, presented a program of films; this event as always, was very well received.

In October, a lecture was given by Mr. J. M. Cree, Power Branch, Engineering Department, whose subject was "Postal Mechanization." Among the many features covered were the electronic letter-sorting equipment, parcel distribution, and mail conveyance. There followed a coloured film, which illustrated many of the items under discussion.

In November, the subject "Woodcroft Telecommunication Centre" was of particular local interest to our members, and Mr. W. Slater, from Edinburgh Area, gave his talk before a packed house, this being one occasion when seating accommodation was at a premium.

In December, a party of members visited the Valleyfield paper mills of A. Cowan & Son, Penicuik. This mill produces high-quality paper, and our party watched the process from raw material to the finished article with much interest. Other features of note were the internal power station used for generating power for the mill, and a very modern boiler house with automatic coal feeding.

In January, one of our members, Mr. H. R. Phillip, gave a very interesting talk on "Transmission," starting from the early days of repeater stations and concluding with the microwave transmission of today.

In February, our last visit of the session was to the works of the Edinburgh Crystal Glass Co., where we saw their famous crystal glass being produced.

At our March meeting, held at the Regional training school, Muirhouse, Edinburgh, Mr. R. J. Hines, Chief Regional Engineer, Scotland, presented a Certificate of Merit gained in the 1963 I.P.O.E.E. Essay Competition to Mr. A. A. Simpson, Glenrothes, Fife, for his essay "Transmission by Waveguide." Among the guests present were

Mr. I. Mathieson, Telephone Manager, Edinburgh, and Mr. E. W. Anderson, Staff Engineer, Local Lines and Wire Broadcasting Branch, Engineering Department.

There followed a lecture by Mr. S. C. Donaldson, from the Regional Training School, entitled "Recent Developments in Subscribers' Internal Apparatus." A few of the items covered in the lecture were the 700-type telephone, the P.M.B.X. No. 2, and subscribers' installation plan numbers. Also on display were a large selection of the items under discussion, which added to a most interesting meeting.

J.M.D.

Stoke-on-Trent Centre

The year 1963-64 was well stamped with evidence of the industriousness of the committee, yet there remains scope for further success, particularly in attracting more members to our lectures.

The session was opened with the attendance of Mr. W. L. A. Coleman, Chief Regional Engineer, Midland Region, who paid tribute to the officers of the Centre for the energy and drive they displayed in their work for the Associate Section. Mr. Coleman then went on to present Mr. K. W. Guy with the Institute's certificate for his prize-winning paper "Interference Investigation."

Our visits were again well supported, and we all look forward to the next program. The following lectures were given:

"Electronic Telephone Exchanges," by Mr. D. L. Benson, Telephone Electronic Exchange Systems Development Branch, Engineering Department.

"Holes in the Ground," by Mr. W. C. Ward, External Plant and Protection Branch, Engineering Department.

"Child Psychology," by Mr. A. Iliffe,

"Lasers," by Dr. D. C. Laine,

"The B.R.M.," by Messrs. Rivers and Fletcher, and

"How to use Ilfrachrome," by Mr. D. S. Moran.

As a result of promotions, a new Chairman and Secretary were elected at the annual general meeting, which was held on 14 April. Our gratitude to the two outgoing officers, Mr. A. E. Patterson and Mr. A. E. Foden, was expressed by the Vice-Chairman, Mr. A. E. Fisher, who further wished them success in their new appointments. The following officers were elected for the 1964-65 session: *President*: Mr. H. Todkill, Telephone Manager; *Chairman*: Mr. J. A. Hart; *Vice-Chairman*: Mr. A. E. Fisher; *Secretary*: Mr. S. P. Hancock; *Assistant Secretary*: Mr. C. Bennion; *Treasurer*: Mr. C. Bell; *Librarian*: Mr. E. J. Foden; *Committee Members*: Messrs. Wilson, Rhead, Roberts, and Winfield; *Auditors*: Messrs. Colclough and Yates.

S.P.H.

Bedford Centre

At the end of March our membership was 124, which seems to indicate that it has found its ultimate level. We are not, however, complacent, and are aiming now at a membership of 150.

The lecture "Developments in Post Office Research" given on 4 March by Mr. J. Piggott, Research Branch, Engineering Department, was extremely interesting; Mr. Piggott interspersed the serious side of his talk with quips and anecdotes which made the evening most enjoyable.

On Thursday, 16 April, the lecture "Recent Developments in Land Sections of Submarine Coaxial Cables" was given by Mr. C. Baker, External Plant and Protection Branch, Engineering Department. Mr. Baker illustrated his lecture with a film he brought with him.

A conference of Chairmen and Secretaries of the three Centres within the Bedford Telephone Area was held on Tuesday, 25 February, under the Chairmanship of Mr. J. H. Facer, Area Engineer. Mr. F. T. Weston, Area Engineer, was also present. The meeting was held with a view to co-ordinating the activities of the three Centres. There was much useful discussion and new friends were made.

E.W.H.P.

Staff Changes

Promotions

Name	Region, etc.	Date	Name	Region, etc.	Date
<i>Senior Executive Engineer to Assistant Staff Engineer</i>			<i>Technical Officer to Assistant Engineer—continued</i>		
Chappell, A. J.	E.-in-C.O.	17.2.64	Olney, M. J.	H.C. Reg.	19.2.64
Hutton-Penman, P. R.	E.-in-C.O.	19.2.64	Wooding, W. G.	H.C. Reg.	19.2.64
<i>Senior Executive Engineer to Regional Engineer</i>			Alexander, A. M.	H.C. Reg.	19.2.64
Morgan, T. J.	L.T. Reg.	24.2.64	Taylor, J. D.	N.W. Reg.	25.2.64
<i>Executive Engineer to Area Engineer</i>			Birks, D. B.	S.W. Reg.	6.2.64
Perkins, J. J.	N.E. Reg.	18.10.63	MacIver, J. C.	Scot.	24.2.64
Postance, J. C. E.	W.N. Reg.	27.11.63	Seager, R. J.	H.C. Reg.	19.2.64
<i>Executive Engineer to Senior Executive Engineer</i>			Cottrell, J. E.	L.T. Reg. to E.-in-C.O.	11.2.64
Leighton, A. G.	E.-in-C.O.	4.2.64	Fletcher, J. C.	H.C. Reg. to E.-in-C.O.	11.2.64
Pritchett, J.	E.-in-C.O.	4.2.64	Robinson, P. M.	L.T. Reg. to E.-in-C.O.	11.2.64
Pitham, S.	E.-in-C.O.	4.2.64	Ramsey, J. C. E.	L.T. Reg. to E.-in-C.O.	11.2.64
Povey, J. A.	E.-in-C.O.	27.2.64	Skingle, G. D.	L.T. Reg. to E.-in-C.O.	11.2.64
<i>Executive Engineer (Open Competition)</i>			Brunt, W. J.	H.C. Reg.	25.2.64
Shanks, P. H.	E.-in-C.O.	6.1.64	Hobbs, G. E.	H.C. Reg.	25.2.64
Rowlands, J. C. H.	E.-in-C.O.	10.2.64	Willis, R. H.	H.C. Reg.	25.2.64
<i>Assistant Engineer to Executive Engineer</i>			Noble, D. H.	H.C. Reg.	25.2.64
Warne, O. W.	S.W. Reg. to E.-in-C.O.	6.1.64	Hope, G. J.	H.C. Reg.	25.2.64
Higgs, H. W.	E.-in-C.O.	5.2.64	James, D. L.	W.B.C.	25.2.64
Martin, A. J.	E.-in-C.O.	5.2.64	<i>Technical Officer to Inspector</i>		
Hammersley, D. E.	E.-in-C.O.	5.2.64	Watkins, A. J.	W.B.C.	15.1.64
<i>Inspector to Assistant Engineer</i>			Quarrie, E.	N.W. Reg.	6.1.64
Lewis, G.	W.B.C.	20.1.64	Dobson, E. G.	L.T. Reg.	7.1.64
Tinsley, W. A.	L.T. Reg.	7.1.64	Child, L. H.	L.T. Reg.	7.1.64
Osborne, W. J.	Scot.	10.2.64	Walker, K. W. A.	L.T. Reg.	7.1.64
Goswell, R. A.	H.C. Reg.	19.2.64	Cornish, B. A.	H.C. Reg.	3.2.64
Chalk, G.	H.C. Reg.	19.2.64	<i>Technician I to Inspector</i>		
Daish, L. H.	S.W. Reg.	28.2.64	Aiston, G.	N.W. Reg.	27.1.64
<i>Technical Officer to Assistant Engineer</i>			Maddrell, D. G.	N.W. Reg.	6.1.64
Davidson, J.	Scot.	13.1.64	Logan, J.	Scot.	13.1.64
Wood, C.	N.E. Reg.	31.12.63	O'Neill, J. R.	Scot.	13.1.64
Owen, J. R.	N.W. Reg.	8.1.64	McLeod, N. M.	Scot.	20.1.64
Mills, J. F.	N.W. Reg.	8.1.64	Timperley, H.	N.W. Reg.	13.1.64
Duffy, J.	N.W. Reg.	24.12.63	Graham, W. E.	Mid. Reg.	17.1.64
Jackson, W.	N.W. Reg.	6.1.64	Lane, T. W.	Mid. Reg.	29.1.64
Goldsworthy, D. D. L.	E.-in-C.O.	31.1.64	Jackson, N.	Mid. Reg.	29.1.64
Howard, P. M.	E.-in-C.O.	10.1.64	Aitken, A. B. S.	H.C. Reg.	20.2.64
McKenzie, S.	Scot.	6.1.64	Ramm, J. E.	N.E. Reg.	19.2.64
Farquhar, D. M.	Scot.	13.1.64	Ball, A. E.	H.C. Reg.	19.2.64
Brodie, A. S.	Scot.	6.1.64	Littleton, W. K.	S.W. Reg.	27.2.64
Brown, A. R.	S.W. Reg.	3.1.64	Young, W. L.	S.W. Reg.	27.2.64
Moreman, E. T.	S.W. Reg.	3.1.64	Waterman, F. R.	S.W. Reg.	27.2.64
Brown, P.	Mid. Reg.	29.1.64	<i>Experimental Officer to Senior Experimental Officer</i>		
Sage, C. E. G. J.	S.W. Reg.	3.1.64	Hines, R. E.	E.-in-C.O.	11.2.64
Keough, J. W.	S.W. Reg.	13.1.64	Sargent, D. J.	E.-in-C.O.	11.2.64
Maddox, D. I.	Mid. Reg.	17.1.64	<i>Senior Scientific Officer (Open Competition)</i>		
Rowell, P. D.	W.B.C.	3.1.64	Jasinski, K. M.	E.-in-C.O.	1.1.64
Feakes, D. V.	H.C. Reg.	22.1.64	Enoch, R. D.	E.-in-C.O.	30.1.64
Rudd, J.	N.W. Reg.	1.1.64	<i>Assistant Experimental Officer (Open Competition)</i>		
Campbell, J. D.	N.W. Reg.	6.1.64	Tim, D. J.	E.-in-C.O.	6.1.64
Purves, A. C.	L.T. Reg.	7.1.64	<i>Assistant (Scientific) (Open Competition)</i>		
Stockdale, E. W.	L.T. Reg.	7.1.64	Moore, P. D. (Miss)	E.-in-C.O.	23.1.64
Cartwright, J.	N.W. Reg.	28.1.64	Stacey, E. C.	E.-in-C.O.	27.1.64
Taylor, K.	N.W. Reg.	28.1.64	Sexton, A. (Miss)	E.-in-C.O.	27.1.64
Townley, T.	N.W. Reg.	28.1.64	Green, J. M. (Miss)	E.-in-C.O.	28.1.64
Brock, A. K.	N.W. Reg.	28.1.64	Hollingdale-Smith, G. V. R. (Mrs.)	E.-in-C.O.	28.1.64
Gabbott, T. S.	N.W. Reg.	28.1.64	Geary, J. F.	E.-in-C.O.	28.1.64
Holmes, R.	N.W. Reg.	28.1.64	Leigh, P. A.	E.-in-C.O.	3.2.64
Cope, A.	N.W. Reg.	28.1.64	Punchard, B. R.	E.-in-C.O.	3.2.64
Burke, J.	N.E. Reg.	29.1.64	Willcox, J. V. (Miss)	E.-in-C.O.	3.2.64
Hodson, J. G.	N.W. Reg.	17.2.64	Scott, S. E.	E.-in-C.O.	5.2.64
Dyer, H.	W.B.C.	3.2.64	Chidley, N. F. G.	E.-in-C.O.	6.2.64
Cattermole, G. W.	H.C. Reg.	17.2.64	Earsdon, M. R. (Miss)	E.-in-C.O.	14.2.64
Cook, G. C.	L.P. Reg.	24.2.64	Yull, E. R.	E.-in-C.O.	17.2.64
Davis, F. A.	L.P. Reg.	24.2.64			
McWhirter, W.	Scot.	29.1.64			

Promotions—continued

Name	Region, etc.	Date	Name	Region, etc.	Date
<i>Assistant (Scientific) (Open Competition)—continued</i>			<i>Draughtsman to Leading Draughtsman</i>		
Cole, S. M. (Miss)	E.-in-C.O.	18.2.64	Bedford, G. F.	E.-in-C.O.	7.2.64
Currie, A. G.	E.-in-C.O.	20.2.64			
Tate, D. J.	E.-in-C.O.	21.2.64			
<i>Leading Draughtsman to Senior Draughtsman</i>			<i>Clerical Officer to Executive Officer</i>		
McConnachie, W. J.	L.P. Reg.	2.1.64	Coles, M. V. (Mrs.)	E.-in-C.O.	6.1.64
			Hunt, R. F.	E.-in-C.O.	27.1.64

Retirements and Resignations

Name	Region, etc.	Date	Name	Region, etc.	Date
<i>Deputy Chief Regional Engineer</i>			<i>Assistant Engineer—continued</i>		
Epps, H. F.	L.T. Reg.	26.2.64	King, W. C.	S.W. Reg.	26.2.64
<i>Senior Executive Engineer</i>			Brown, J. V.	L.T. Reg.	28.2.64
Harmston, A. T.	E.-in-C.O.	19.2.64	Jackson, H. T.	L.T. Reg.	29.2.64
<i>Executive Engineer</i>			Young, G. A.	L.T. Reg.	29.2.64
Banham, S. H.	E.-in-C.O.	13.1.64	Wilson, S. B. (Resigned)	N.W. Reg.	16.2.64
Mann, L. A.	E.T.E.	30.11.63	Haddock, G. A. (Resigned)	E.-in-C.O.	28.2.64
Taylor, J.	N.W. Reg.	11.12.63	<i>Inspector</i>		
Lucas, V. F.	H.C. Reg.	12.12.63	Hope, F. G.	L.T. Reg.	3.1.64
Sherriff, L. C.	L.T. Reg.	19.1.64	Shimmin, G. A.	N.W. Reg.	5.1.64
Bouquet, H. F.	E.-in-C.O.	31.1.64	Robinson, E. P.	L.T. Reg.	20.1.64
Smith, T. M. (Resigned)	E.-in-C.O.	31.12.63	Sutcliffe, W.	N.W. Reg.	26.1.64
Bell, D.	L.T. Reg.	27.2.64	Slater, S. R. R.	N.E. Reg.	24.6.63
<i>Assistant Engineer</i>			Musker, H. J.	W.B.C.	25.2.64
Greasley, E. G.	E.-in-C.O.	9.1.64	Notman, W.	Scot.	29.2.64
Collier, W. B.	N.W. Reg.	7.1.64	<i>Scientific Officer</i>		
Smith, G.	L.T. Reg.	11.1.64	Jones, R. P. (Resigned)	E.-in-C.O.	6.1.64
Phillips, C. G.	W.B.C.	20.1.64	<i>Technical Assistant</i>		
Ferguson, C.	Scot.	21.1.64	Lyndoe, H. L.	E.-in-C.O.	31.12.63
Waggott, J. T. (Resigned)	E.-in-C.O.	31.12.63	<i>Executive Officer</i>		
Carpenter, A. E.	S.W. Reg.	3.2.64	Hicks, G.	E.-in-C.O.	3.1.64
Smith, A. E.	L.T. Reg.	12.2.64	Aaron, F. C.	E.-in-C.O.	9.1.64
Watt, J. P.	Scot.	14.2.64			
Slight, C. G. H.	E.-in-C.O.	21.2.64			

Transfers

Name	Region, etc.	Date	Name	Region, etc.	Date
<i>Area Engineer</i>			<i>Assistant Engineer—continued</i>		
Gilbey, P. D.	Trinidad to N.E. Reg.	27.1.64	Smith, N. J. W.	E.-in-C.O. to L.T. Reg.	20.1.64
<i>Executive Engineer</i>			Smith, J. A.	E.-in-C.O. to H.C. Reg.	20.1.64
Powell, H. J.	E.-in-C.O. to Ministry of Aviation	13.1.64	Lenton, D. J.	E.-in-C.O. to East Africa	20.1.64
Sinnicks, A. C.	H.C. Reg. to East African Harbours and Railways	3.2.64	Taylor, C. H.	E.-in-C.O. to H.C. Reg.	27.1.64
<i>Assistant Engineer</i>			Reilly, P.	E.-in-C.O. to L.T. Reg.	27.1.64
Barnaby, R. E.	E.-in-C.O. to Mid. Reg.	1.1.64	Hill, H.	E.-in-C.O. to L.T. Reg.	3.2.64
Muir, B. R.	E.-in-C.O. to Ghana	3.1.64	Clark, L.	Trinidad to E.-in-C.O.	3.2.64
Loy, A. F.	L.T. Reg. to E.-in-C.O.	13.1.64	Harrison, D. J.	E.-in-C.O. to East Africa	9.2.64
			Ellis, G.	Trinidad to E.-in-C.O.	10.2.64
			<i>Technical Assistant</i>		
			Webber, A. L. D.	E.-in-C.O. to H.C. Reg.	20.1.64

Deaths

Name	Region, etc.	Date	Name	Region, etc.	Date
<i>Assistant Engineer</i>			<i>Inspector</i>		
Taylor, I. S.	Scot.	5.1.64	Davey, R. P. S.	S.W. Reg.	3.11.63
Dunncliffe, C.	N.W. Reg.	21.1.64	Green, V. J.	S.W. Reg.	6.2.64
Headworth, J. A.	Mid. Reg.	2.2.64	<i>Senior Draughtsman</i>		
Malin, L. F.	L.T. Reg.	17.2.64	Holding, J. H.	H.C. Reg.	16.2.64

BOARD OF EDITORS

D. A. BARRON, C.B.E., M.Sc., M.I.E.E., Chairman.
L. F. SCANTLEBURY, Whit.Sch., A.C.G.I., D.I.C., M.I.E.E.
T. H. FLOWERS, M.B.E., B.Sc.(Eng.), M.I.E.E.
W. J. E. TOBIN, B.Sc.(Eng.), A.C.G.I., D.I.C., M.I.E.E.
E. J. MARKBY, A.M.I.E.E.
E. HOARE, B.Sc., M.I.E.E.
R. F. WALDEGRAVE.
A. G. LEIGHTON, B.Sc.(Eng.), A.M.I.E.E., Managing Editor.
J. MARTIN, B.Sc.(Eng.), A.M.I.E.E., Deputy Managing Editor.
J. A. POVEY, A.M.I.E.E. } Assistant Editors.
R. A. SUDELL. }
B. FARR, A.B.I., Secretary-Treasurer.
B. CROSS, Advertisement Manager.

Copyright

The entire contents of this Journal are covered by general copyright, and special permission is necessary for reprinting long extracts, but editors are welcome to use not more than one-third of any article, provided that credit is given at the beginning or end thus: "From *The Post Office Electrical Engineers' Journal*."

The Board of Editors is not responsible for the statements made or the opinions expressed in any of the articles in this Journal, unless such statement is made specifically by the Board.

Subscriptions and Back Numbers

The Journal is published quarterly, in April, July, October and January, at 3s. per copy; the post-paid price is 4s. per copy (16s. per year) via inland mail, and 4s. 3d. (17s., or 2 dollars 75 cents Canada and U.S.A., per year) via overseas mail. Back numbers will be supplied, if available, price 3s. (4s. inland mail, 4s. 3d. overseas mail) per copy. With the exception of April and

July 1961 Journals, copies of the January 1963 and all earlier Journals are no longer available. Orders should be sent to *The Post Office Electrical Engineers' Journal*, G.P.O., 2-12 Gresham Street, London, E.C.2.

Employees of the British Post Office can obtain the Journal through local agents.

Binding

Readers can have their copies of volumes bound at a cost of 15s. by sending the complete set of parts to the local Post Office distribution agent or to *The Post Office Electrical Engineers' Journal*, G.P.O., 2-12 Gresham Street, London, E.C.2.

Remittances

Remittances should be made payable to "*The P.O.E.E. Journal*" and should be crossed "& Co."

Advertisements

All correspondence relating to advertisement space reservations, copy, proofs, etc., should be addressed to the Advertisement Manager, *The Post Office Electrical Engineers' Journal*, G.P.O., 2-12 Gresham Street, London, E.C.2.

Communications

With the exceptions indicated above, all communications should be addressed to the Managing Editor, *The Post Office Electrical Engineers' Journal*, G.P.O., 2-12 Gresham Street, London, E.C.2. Telephone: HEADquarters 1234.

Model Answer Books

Books of model answers to certain of the City and Guilds of London Institute examinations in telecommunications are published by the Board of Editors. Details of the books available are given at the end of the Supplement to the Journal.

Book Reviews

"Les Hyperfrequences." R. Rigal. Eyrolles, Paris. 332 pp. 228 ill. 59.00 F.

This is a scholarly book for mathematically inclined students to whom microwave engineering is still a matter of theory rather than practice. The volume is officially sponsored by the Ministry of Posts and Telecommunications in Paris. The author, Monsieur R. Rigal, Directeur des Etudes de l'Ecole Nationale Supérieure des Télécommunications, has based his book on a series of lectures on microwaves in the course of which he develops the theory of radio-wave propagation, transmission in waveguide and in coaxial tubes.

The book opens with a thorough survey of the classical mathematical treatment of Maxwell's equations and line transmission theory. The English reader may find the symbols used by the French tiresome because of their unfamiliarity, but the chapter is a good summary of the groundwork.

The second chapter deals with electromagnetic wave transmission, reflection at a plane surface, the effect of dielectrics and refraction generally. The author proceeds to analyse wave transmission in waveguides and coaxial cables: first he takes the loss-free case, then he follows it by introducing attenuation and discontinuities. Ferrite devices are discussed. A chapter on microwave resonance in cavities of various shapes is followed by an account of waveguide filters and methods of designing them using conventional filter theory. A chapter on microwave aerials and radiating systems including electromagnetic lenses and dielectric radiators is a useful introduction to this subject; it is followed by a brief account of microwave propagation with a few details on atmospheric absorption over the range 3 to 100 Gc/s.

To a microwave engineer this book will seem academic because it is largely analytical and tends to ignore practical

aspects of microwave applications. It is in fact a teacher's book rather than an engineer's. He may benefit from its breadth of treatment of theory but he is unlikely to derive many new engineering ideas from it. The advanced student of radio, provided he can read French, will find its wealth of theory valuable basic reading, which is as it should be, because the book is written by a university teacher for students and young engineers.

The printing and paper are excellent; the covers are of thin card—it is almost a paper-back—so that the book will not stand much rough handling.

C.F.F.

"Printed Wiring and Printed Circuit Techniques." The Electronic Engineering Association and Iliffe Books, Ltd. 49 pp. 5s.

This concise booklet is rather like an expanded "design guide," and covers a range of topics including terminology, types and properties of copper-clad insulating boards, artwork and master negatives, production processes, machining, mass soldering, mounting of components, and a few words on varnishing and encapsulation.

It could be helpful as reference notes for draughtsmen and designers, e.g. it contains numerical data such as grid magnitudes, current-carrying capacities, conductor spacing, dimensions for component connexions, and various tolerances.

While of course not strictly within the definition of "printed" wiring, a few notes on other processes in commercial use which produce a similar end product, e.g. die-stamped wiring, etc., would be a useful inclusion in the next edition.

Another small improvement would be greater precision about the characteristics of gold, palladium, and rhodium-plated coatings, and the thicknesses of these required for good contacts.

A.A.N.

SPACE FOR PRESTIGE . . .

BUT
CABLES
FOR SURE COMMUNICATIONS

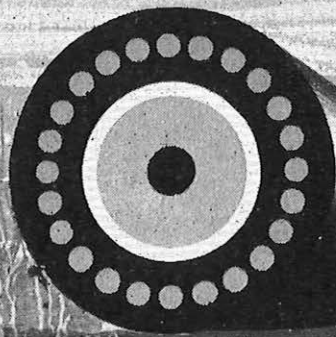

With the environment of space beyond the control of man, only submarine telephone cables can provide intercontinental communications of proven reliability, economy and freedom from interference. Submarine Cables Ltd. can supply cable, repeaters, cable-laying gear and services, and—through AEI—terminal equipment.

**SUBMARINE
CABLES LTD**

GREENWICH · LONDON · SE10 OWNED JOINTLY BY AEI AND BICC



TELECOMMUNICATIONS CABLES

Pirelli General are in a position to advise on complete Telecommunications schemes and are organised to manufacture and install cables for distribution and trunk services; also carrier and all types of coaxial cables.

Pirelli General also manufacture cables to meet special requirements of Public Utilities or of industry.

ADCOLA PRODUCTS LIMITED SOLDERING INSTRUMENTS

FOR
TOTAL EFFICIENCY

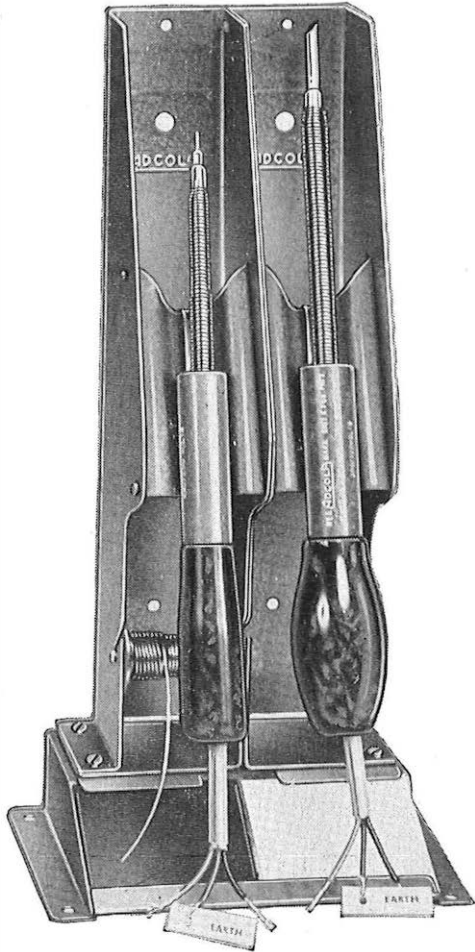

FOR CATALOGUES APPLY DIRECT TO SALES DEPT.

ADCOLA PRODUCTS LTD.

ADCOLA HOUSE
GAUDEN ROAD
LONDON, S.W.4

Telephone: MACAULAY 4272 & 3101
Telegrams: SOLJOINT, LONDON S.W.4

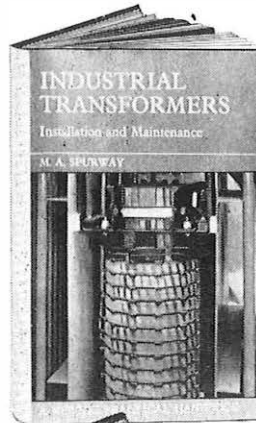

NEWNES PRACTICAL HANDBOOKS...

... a new series for electrical engineers. Emphasis throughout is essentially on the practical aspects of the subject. The treatment is largely pictorial, and where appropriate, specially-staged picture sequences are included. The first four titles in the series are:

INSTALLATION AND MAINTENANCE OF INDUSTRIAL TRANSFORMERS

M. A. Spurway, A.M.C.T., A.M.I.E.E.

Shows what can be done to ensure long, trouble-free service from a transformer. The recommendations are appropriate to oil-immersed transformers of ratings up to about 1,000 kVA and about 33 kV.

110 pages, 61 illustrations.

CABLE JOINTING

R. Thompson, Assoc.I.E.E.

Gives a comprehensive picture of jointing requirements for cables up to 11 kV such as are used in electrical distribution systems for normal public supply and in large industrial plants. Also shows alternative methods.

112 pages, 73 illustrations.

INSTALLATION AND MAINTENANCE OF ELECTRIC MOTORS

R. Rowlinson, M.I.E.E., Mem.A.I.E.E.

Discusses the factors governing the choice of motor and control gear for a particular application, and the installation, maintenance and general overhaul of this equipment and its associated drive.

102 pages, 52 illustrations.

INSTALLATION AND MAINTENANCE OF INDUSTRIAL SWITCHGEAR

E. A. Reeves, D.F.H.(Hons.), A.M.I.E.E.

Describes by means of particular examples the procedure for installing and maintaining all types of industrial switchgear falling within the voltage range of 415V to 11kV.

112 pages, 71 illustrations.

Fact books for the pocket of the man on the job!

7s. 6d. cut flush edition
10s. 6d. cased edition

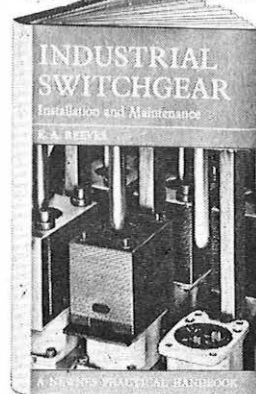
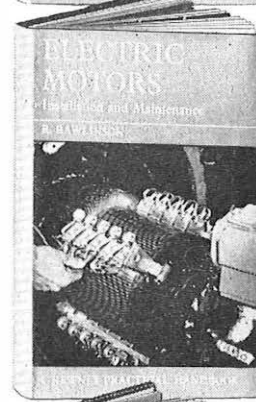
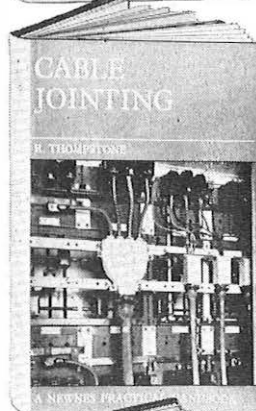

ORDER HERE

Please send me the following NEWNES PRACTICAL HANDBOOKS

-Industrial Transformers
 -Cable Jointing
 -Electric Motors
 -Industrial Switchgear
- 7s. 6d. edition/10s. 6d. edition. (Delete edition not required)

FROM
ALL
BOOK
SELLERS

Name
Address

...or, in case of difficulty, use this handy order form TODAY.

Simply complete and post this order with your remittance plus postage (7s. on one or two books, 1s. 6d. on three or four books), to George Newnes Ltd., Tower House, Southampton Street, London, W.C.2.

P.O.E.E.J.
NEWNES

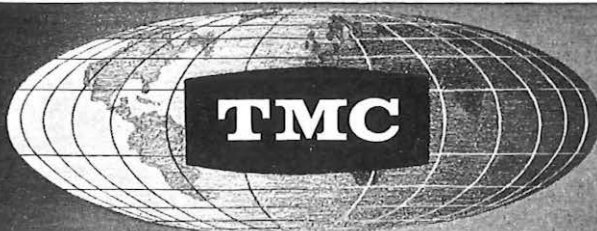

**TELECOMMUNICATIONS
THROUGHOUT
THE WORLD**

**CARRIER
TELEPHONE
EQUIPMENT**
for the
**SNOWY MOUNTAINS
SCHEME**

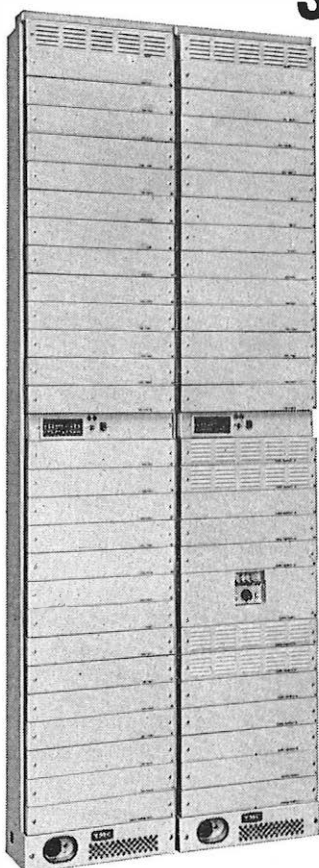
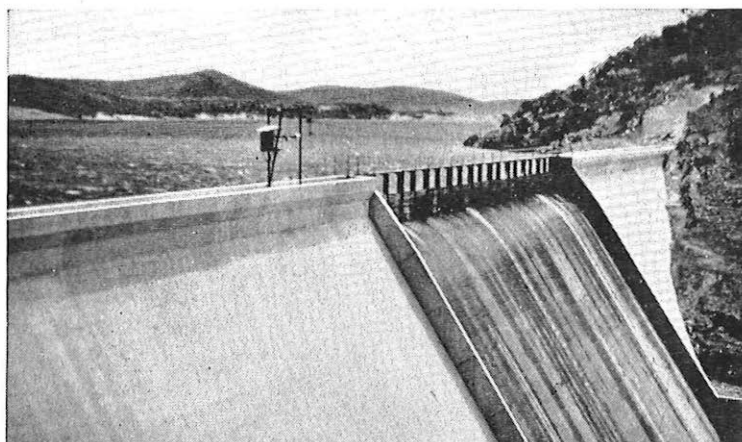
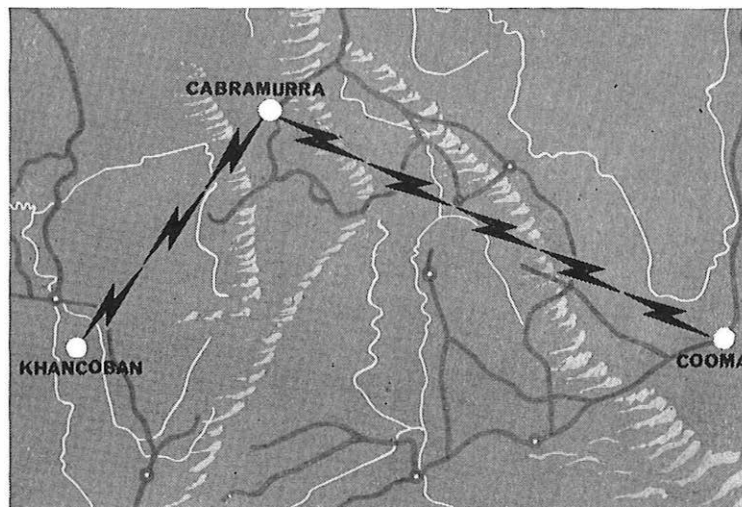

TMC Carrier Telephone Equipment was chosen to provide communications for the Snowy Mountains Scheme—the world's largest water conservation and hydro-electric power project. The system links Cooma, Cabramurra and Khancoban. The terminal stations are equipped with TMC 60 circuit system, type R60N, on wide-band radio bearers. The R60N system can be extended to provide up to 120 high quality telephone circuits.

This installation is one of the many communications schemes in which TMC has played a significant role in countries throughout the world. You are invited to write for information about this and other telecommunication systems, and details of the service offered by the TMC Planning Engineers.

TMC

TELEPHONE MANUFACTURING COMPANY LIMITED

Transmission Division

Sevenoaks Way · St. Mary Cray · Orpington · Kent · England · Tel: Orpington 27020 · Telex: 28115

A MEMBER OF THE  GROUP OF COMPANIES

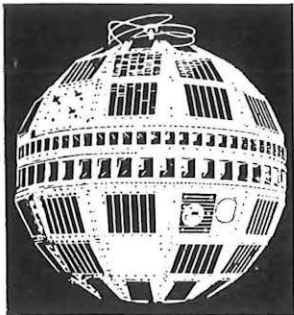

International authorities
discuss current and
future projects

TELECOMMUNICATION SATELLITES

Theory, practice, ground stations, satellites, economics
K. W. GATLAND, F.R.A.S., F.B.I.S., A.R.Ae.S.

This book brings together many international authorities to explain in detail the projects they are working on and future lines of development. Ranging from the Echo balloon satellite to active repeater satellites, this comprehensive survey is an indispensable book for all engaged in the telecommunications field.

85s net by post 86s 4d 440 pp. illustrated

obtainable from leading booksellers

ILIFFE Books Ltd.
DORSET HOUSE STAMFORD STREET LONDON SE1

**OXLEY
DEVELOPMENTS
CO. LTD.**



OXLEY SUBMINIATURE AIR DIELECTRIC TRIMMERS

A continuous study in the laboratory and in the field has resulted in a further development in Oxley subminiature air dielectric trimmers, the rotor and the stator both being made of solid metal.

This results in:

- (1) The elimination of practically all soldered joints.
- (2) A positive increase in mechanical rigidity and improved electrical stability.
- (3) A high order of consistency in capacity.

In other respects the trimmers retain all those facilities which have made them the inevitable choice of professional equipment in which reliability is the dominant requirement.

BRITISH
FOREIGN
PATENTS

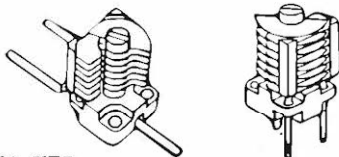

ACTUAL SIZE

Write for technical details of these and other Oxley products

OXLEY DEVELOPMENTS CO. LTD., ULVERSTON, LANCASHIRE

WHITELEY

miniature

ELECTRONIC COMPONENTS

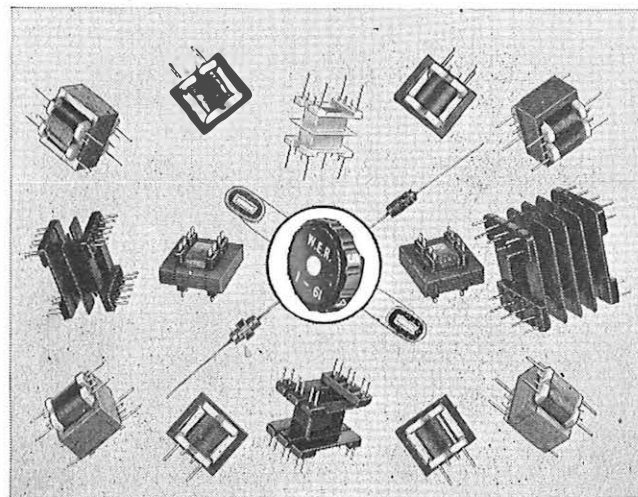

**Reduce your problems
and equipment size
to a minimum**

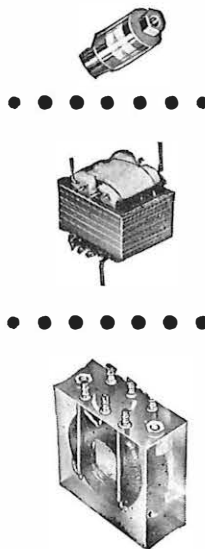

The above illustration shows a range of moulded bobbin assemblies for small transformers and chokes, together with a miniature volume control and switch.

Illustrated at left are: A Potentiometer mounting—an illustration of potting and casting material, a small iron cored choke which is representative of the many types we manufacture and an example of a toroidal winding on a mu-metal core encapsulated in epoxy resin.

Our technical advisory staff are always available to discuss your individual problems.

GET IN TOUGH WITH US NOW!

WHITELEY ELECTRICAL RADIO CO. LTD.
MANSFIELD • NOTTS

Telephone: Mansfield 1762/5



TCL covers the world

TCL supplies all types of dry-core and plastic telephone cables and is the largest manufacturer in Europe exclusively concerned with telephone, telegraph, sound and TV cable networks.

TELEPHONE CABLES LIMITED

Dagenham, England DOMinion 6611 Cables: Drycore Dagenham.

THE ORGANISATION WITH 125 YEARS' EXPERIENCE

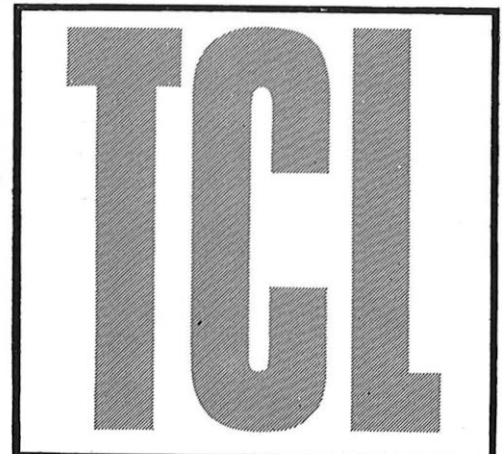

Take the strain on any type of cable

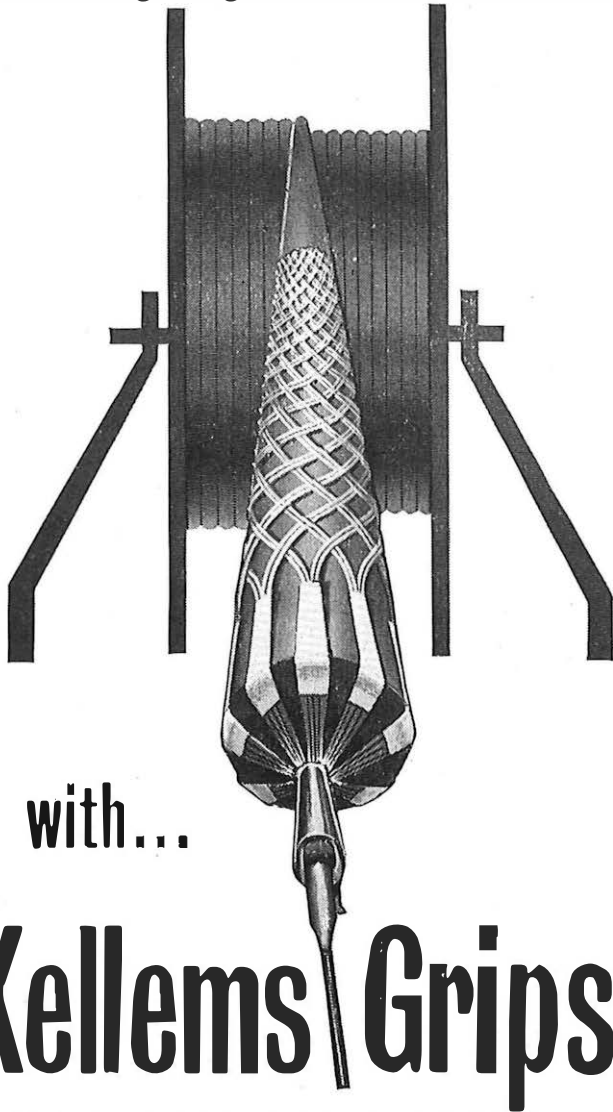

with...

Kellems Grips

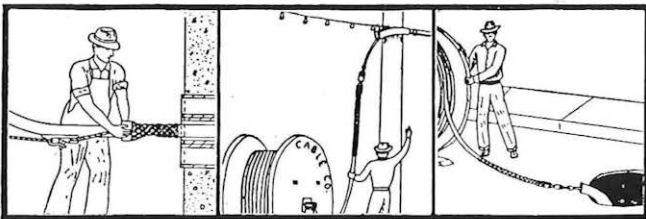

Kellems grips for pulling support or strain relief are quickly installed, adjusted or removed. They are neat in appearance, safe to handle and fully salvable. In stainless steel or bronze, they are of simple construction and light weight. Available in sizes and shapes for most cable applications.

IT PAYS TO HAVE GOOD CONNECTIONS



HARVEY HUBBELL LIMITED
123A GLOUCESTER RD., LONDON, S.W.7.
Telephone: FREmantle 3371

ROOTES TEMPAIR

AIR CONDITIONING

AIR at its best, temperature controlled and cleaned. Air with that natural outdoor quality that only REAL air conditioning gives you.

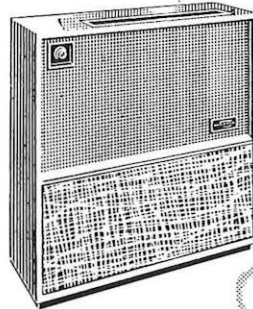
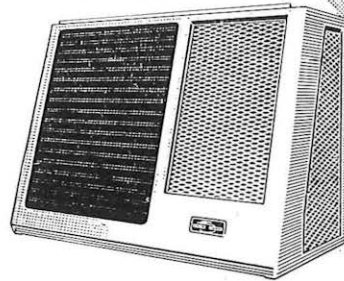

FOR CELLARS

Rootes Tempair Cellar Cooler maintains an even, natural temperature.

BOARDROOMS

Rootes Tempair Director free-standing unit delivers heated or refrigerated air, cleans and dehumidifies. Quiet running.

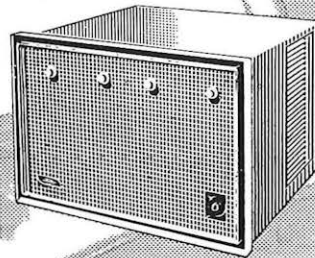

FOR BUSINESS

Rootes Tempair Pacific, window or wall models. Modern styling, complete and efficient air-conditioning. Freedom from noise and dust.

AND INDUSTRY

Rootes Tempair '5000' industrial air-conditioning for laboratories, computer rooms, small workshops, etc. High output, water or air cooled, economical in floor space.

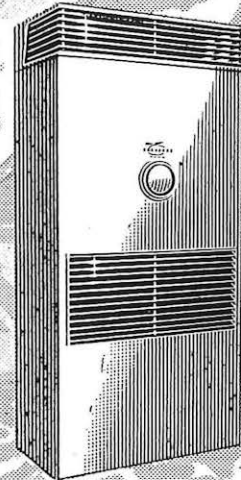

Send this coupon today for details of range

To: **TEMPAIR LIMITED · ROMNEY PLACE · MAIDSTONE KENT · ENGLAND**
A Rootes Group Company.

Tick whichever applicable

Name _____
Address _____

- CELLAR COOLER
- DIRECTOR
- PACIFIC
- TEMPAIR '5000'
- CUFC 4

Marconi self-tuning H.F system—
the first in the world to be station
planned from input to output.



breakthrough

MST 30kW transmitter type H1200

An h.f linear amplifier transmitter for high-grade telecommunications.
Frequency range: 4-27.5 Mc/s.
Output power: 30 kW p.e.p, 20 kW c.w.
Meets all CCIR Recommendations.

saves 80% floor space

Transmitters can be mounted side by side and back to back or against a wall. Floor-ducts are eliminated and all power supply components are built-in. These features lead to smaller, simpler, cheaper buildings or more services in existing buildings.

rugged reliability

R.F circuits have been simplified and the number of mechanical parts reduced to a minimum. Highest engineering standards are applied to the design of these parts: stainless steel shafts in ball-bearings in heavy, rigid, machined castings; stainless steel spur gears meshing with silicon bronze; heavy r.f coil contacts with high contact pressure. Specified performance is maintained with ample margins.

simplicity

MST reliability allows continuous unattended operation with extended or remote control, saving maintenance and operating staff. Any fault in the servo control circuits can quickly be located with simple test routines. Transistors and printed wiring give these circuits maximum reliability.

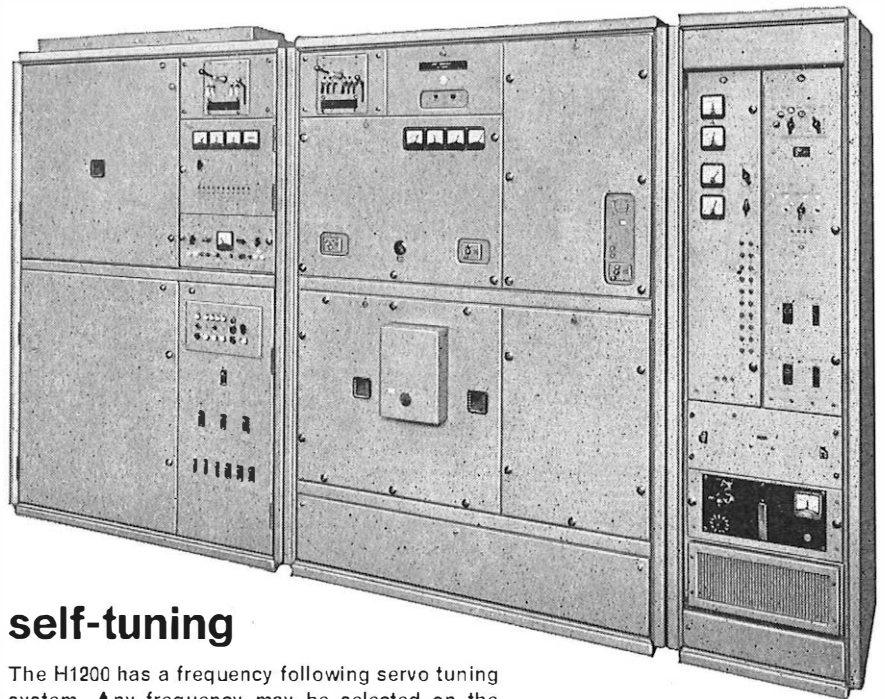

self-tuning

The H1200 has a frequency following servo tuning system. Any frequency may be selected on the synthesizer decade dials in the associated MST drive equipment; the unattended transmitter automatically tunes itself in an average time of twenty seconds. Final stage tuning and loading servos continuously ensure automatic compensation for changes in aerial feeder impedance caused by weather conditions. Self-tuning gives *one-man* control of an entire transmitting station.

Marconi telecommunications systems

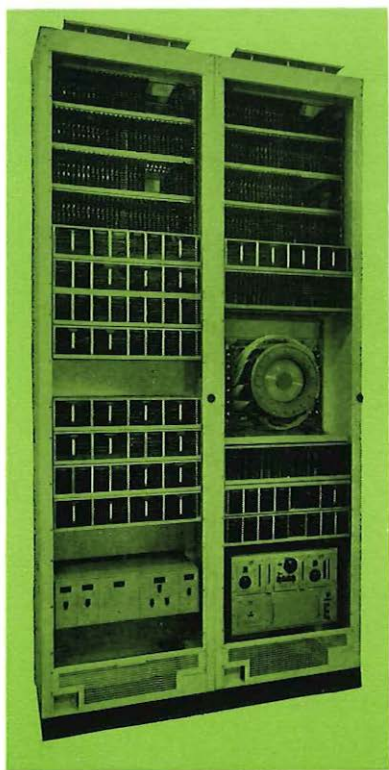

STC Equipment for the New Hull Exchange

Kingston-upon-Hull Corporation Telephone Department—the only Municipal Telephone undertaking in the United Kingdom—celebrates its Diamond Jubilee with the opening of its new 9,700 line Central Automatic Telephone exchange—CIVIC. Manufactured and installed by STC, this exchange is being equipped with the first electronic drum metering equipment of its kind in the world—which eliminates the normal reading of subscribers meters. The line and drum racks for 4,000 subscribers are illustrated above. Designed to permit the introduction of fully mechanized handling of subscribers'

accounts, this electronic equipment includes the following facilities.

- (a) Greater flexibility in tariff charges, including the ability to make easy changes in local call timing.
- (b) The recording of separate readings for local and Trunk/International calls.
- (c) Remote indication of any subscribers' meter totals at any time, facilitating the production of accounts at short notice.
- (d) The ability to identify calling lines, which is of use in certain circumstances, e.g. to identify a coin box from which a '999' emergency call has been made.
- (e) Storage facilities for purposes other than metering, e.g. the ability to give a visual identification of called subscribers' numbers on operator controlled calls.

Altogether Standard Telephones and Cables Limited has manufactured and installed equipment for 17 Public Automatic exchanges for the Hull Corporation with a total of over 70,000 lines. STC are also installing the new Anson exchange for the British Post Office which is the Group Switching Centre for all STD Traffic in the Hull Area.

Standard Telephones and Cables Limited, Telephone Switching Division, Oakleigh Road, New Southgate, London, N.11. Telephone ENTerprise 1234. Telex 21612.

STC

world-wide telecommunications and electronics

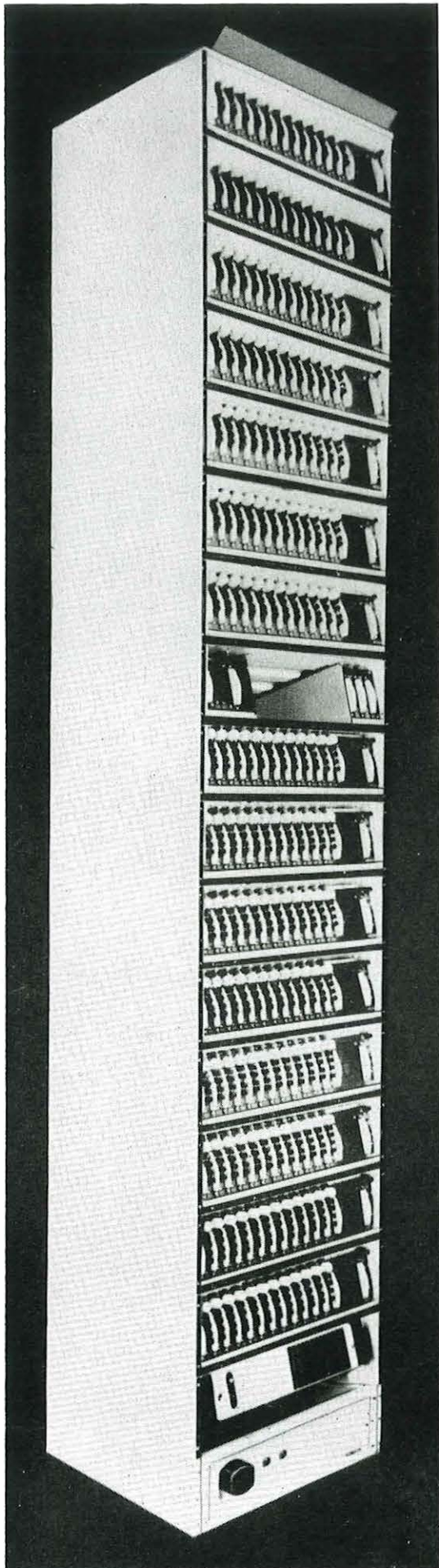

G.E.C. C.A.S.E. saves 44% space, gives

G.E.C. have radically improved transmission equipment design with their new Card Assembled Shelf Equipment. This equipment exploits the latest developments in components, materials and production methods, using entirely new construction techniques.

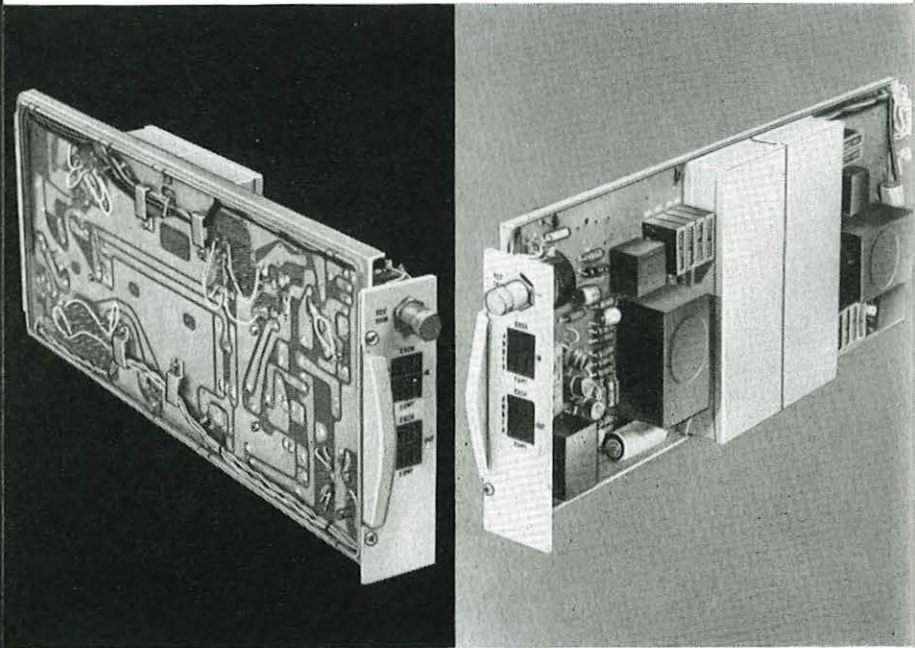

C.A.S.E. Channel Card.

9 ft. C.A.S.E. Channel Rack.
Shelves are inclined at 15°
to increase the airflow over
components.

(Card Assembled Shelf Equipment) easier access, easier maintenance

C.A.S.E. makes access easy—as simple as drawing a card from the pack. Space economy of 44% can be obtained in new stations using C.A.S.E. compared with conventional rack designs. Economies in space are also obtained when adding C.A.S.E. to existing transmission systems.

Cost is less—no rack pre-wiring is required, and further equipment can be added easily as necessary. G.E.C. C.A.S.E. conforms to C.C.I.T.T. dimensions and G.P.O. 62-Type specifications. C.A.S.E. is designed to take full advantage of future micro-miniaturisation techniques.

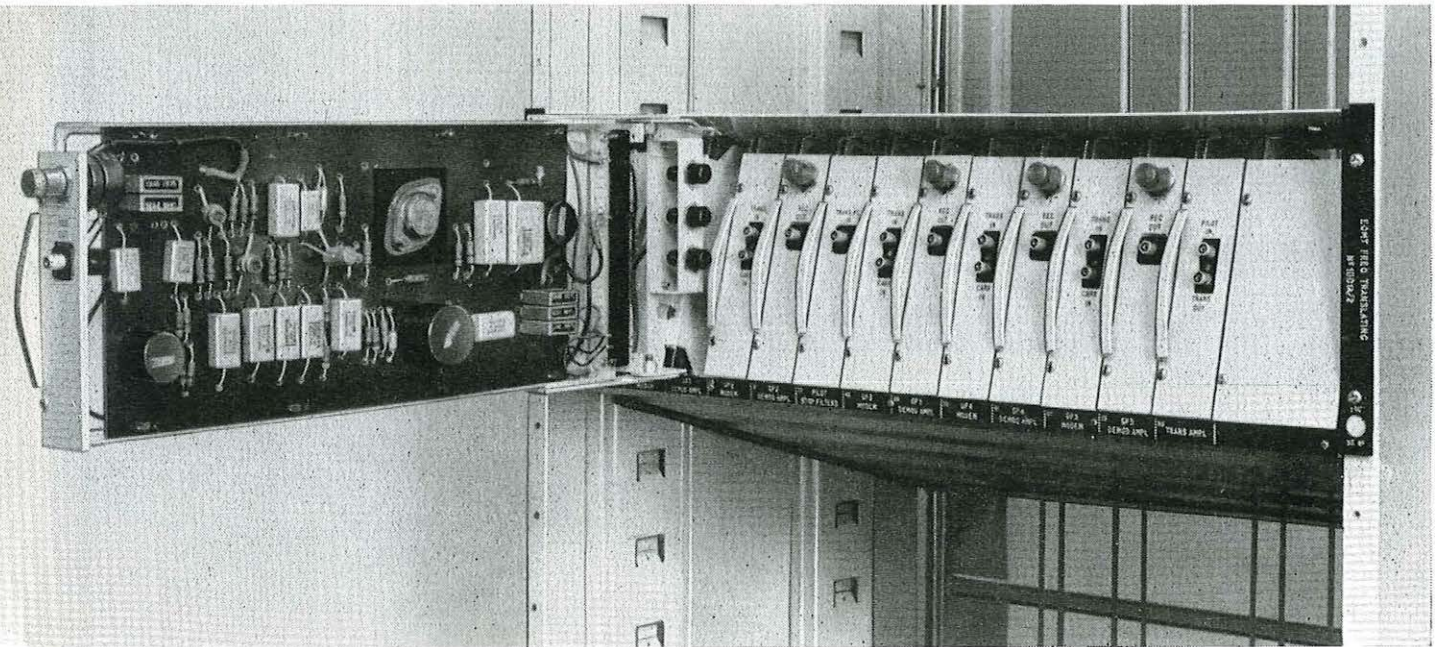

C.A.S.E. Demodulator Amplifier Card with the test adaptor in position making the card fully accessible.



everything for telecommunications



AN EXTRA EARPIECE FOR THE 706 TELEPHONE

Post Office approved, this STC telephone earpiece gives listening facilities for a second person on the new British Post Office 706 type telephone.

Conversations can be recorded by stenographer Great time saver and *aide memoire* for the busy executive Earpiece disconnected when hung up No 'click' audible when earpiece is brought into use Listener can use extra earpiece when reception is weak or in noisy surroundings Exceptionally light and compact Now available in all 706 telephone standard colours—black, grey, ivory, green, red, yellow and blue. Write, 'phone or Telex for Leaflet D/110. UK Subscribers connected to Post Office lines should apply to their Local Telephone Manager. Standard Telephones and Cables Limited, Telephone Switching Division, Oakleigh Road, New Southgate, London, N.11. Telephone ENTerprise 1234. Telex 21612.

world-wide telecommunications and electronics

STC

over thirty types—and all from stock!

The range of high-quality Broad Band Microwave Components offered by MEL now includes more than thirty units—all 'available from stock' all ruggedly constructed, all featuring very wide coverage and all of extremely compact design. It is from MEL's own extensive manufacturing and application experience—backed by world-renowned research facilities, that the range of microwave components has been developed, with new items of proven quality being continuously added to the list.

Extending in frequency from 1 to 11.5 Gc/s, in five bands, the range of components includes hybrids, isolators, filters and circulators—in waveguide, stripline or co-axial form.

Behind the production of each item lies a microwave problem already effectively solved by MEL, and within the range, there may lie the 'ready made' solution to one or many of your own microwave problems.

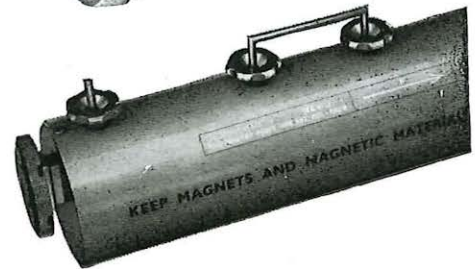
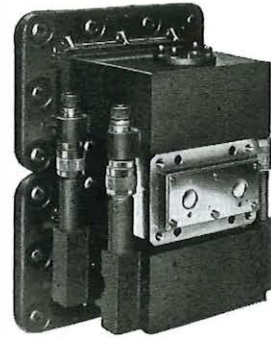

Write for Microwave Components Catalogue to:
MULLARD EQUIPMENT LIMITED

Manor Royal · Crawley · Sussex · Telephone: Crawley 28787

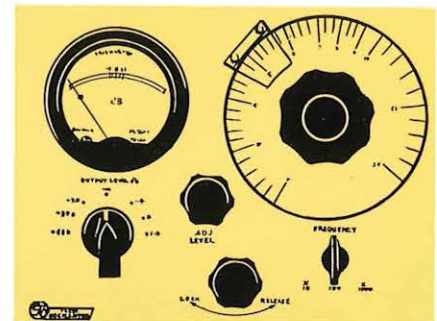
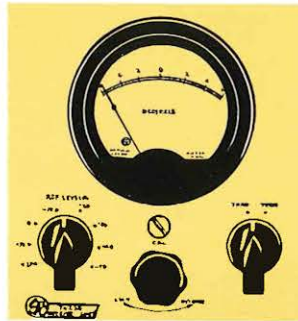
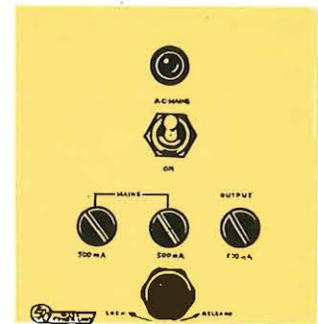
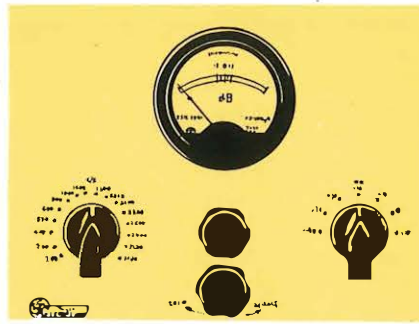
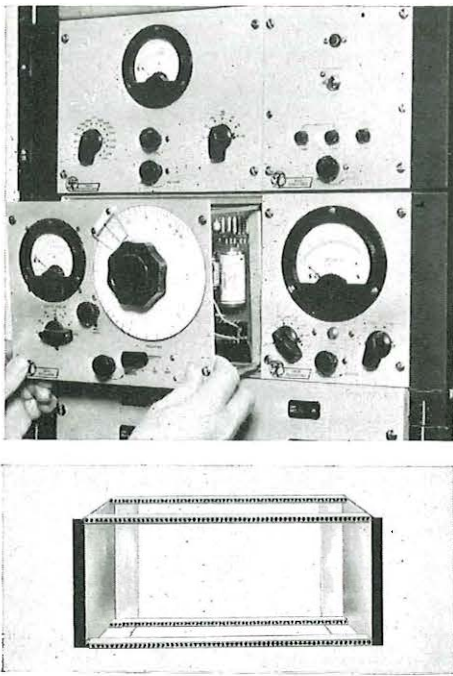

NOVEL/VERSATILE/COMPACT The new Testing Apparatus Practice is a form of construction which solves the problem of mounting test gear on racksides having differing fixing centres. It also makes optimum use of the space available. The panels slide into a framework and lock in position, electrical connexions then being automatically made via a multi-way plug and socket. Frameworks are available in several versions to suit different forms of racksides, and a portable version can also be supplied. Interchangeability of panels is thus assured. Printed-board circuitry is used in the panels to economize in space and simplify wiring, and transistors are used throughout.

Available now are:

74233 Oscillator
20 c/s–20 kc/s
+10, 0, -4, -10, -20, -30, -40 dbm (600Ω)

74234 Receiving Unit
20 c/s–20 kc/s
-26 to -56 dbm (600Ω)

74235 Sending Unit
16 fixed frequencies from 200 c/s to 3 400 c/s
+10, 0, -4, -10, -20, -30, -40 dbm (600Ω)

74232 Power Unit
Operates from 115V ($\pm 15\%$) or 230V ($\pm 15\%$)
45–66 c/s a.c. Will operate the 74233,
74234, and 74235 simultaneously.

Write, 'phone or Telex for leaflets: Standard Telephones and Cables Limited, Testing Apparatus Division, Corporation Road, Newport, Mon. Telephone Newport 72281 (STD: ONE 3 72281) Telex 49367. London Office: Telephone ALBERT Dock 1401 (Ext. 758).

world-wide telecommunications and electronics **STC**



NO POWER SUPPLY NO EXTRA WIRING NO MAINTENANCE

Designed for telephone location and accurate dial-out in areas of low light level or in cases of lighting failure where immediate access to emergency services may be vital, the new "DIALITE" —will give many years of trouble-free service, repaying in convenience its low initial cost.

This self-illuminated dial—another first in telephone instrument design from Ericsson—can be fitted when specified on all types including the "Etelux" luxury telephone.



ERICSSON TELEPHONES LTD. ETELCO LTD.

A Principal Operating Company of the Plessey Group.

Head Office and Main Works, Beeston, Nottingham. Telephone 254831. Telex 37666

BR76

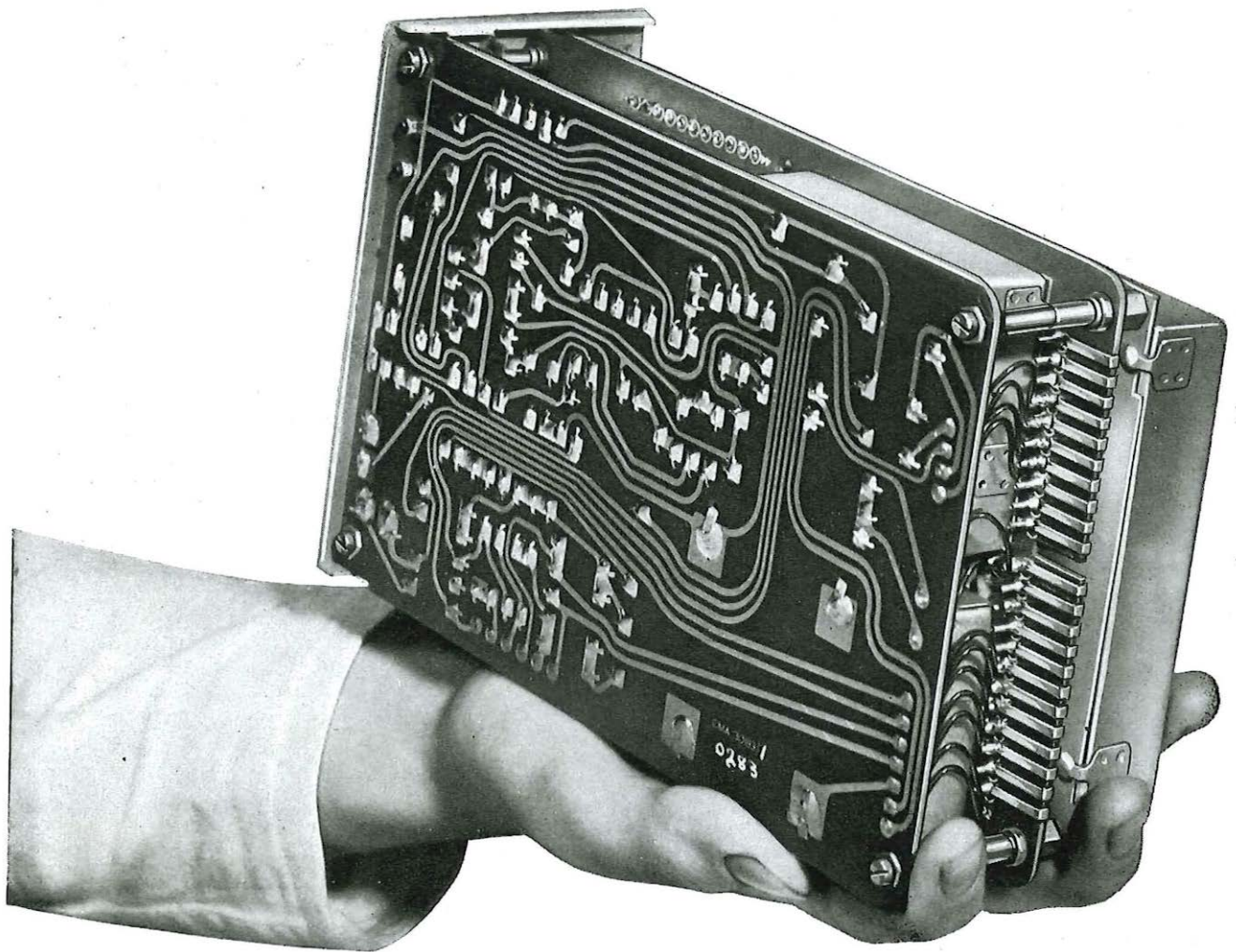

WEIGHT'S A MATTER OF TRADITION...

One thing modern technology should have taught us: things don't necessarily need to be as big or as heavy as they often are.

Weight's generally just a matter of tradition.

Take the new ATE Type CM Carrier, for example...

revolutionary design

By discarding conventional design, AT&E have brilliantly succeeded in producing a compact, fully reliable carrier *only one-third the weight* of an equivalent valve equipment.

The secret? The card-mounted printed circuit.

ATE Type CM Carrier Equipment has already been chosen for microwave, open-wire and cable carrier connections by

leading organizations throughout the world.

savings all round

They know what this extraordinary saving of weight and power-consumption—with no loss of efficiency of reliability—can do. That means savings, too, in prime and operating costs.

Fully transistorized/ Plug-in printed circuits/Mains or battery operation/Optional in-built out-band 3825 c/s low or high level signalling for ringdown or dialling/Suitable for extension to existing valve equipment/Easy accessibility/One third the size of equivalent valve equipment. **Automatic Telephone & Electric Co. Ltd., 8 Arundel St., London WC2. Telephone: Temple Bar 9262.**



Pitman Books

Radio and Electronic Components: Volume III

FIXED CAPACITORS

G. W. A. Dummer 2nd Edition

Every type is described, including recently developed evaporated dielectrics. There is full data on each, and a classified bibliography. 45s. net

AUTOMATIC VOLTAGE REGULATORS & STABILIZERS

G. N. Patchett 2nd Edition

Much new material has been added for this edition on tap change equipment and transistor stabilizers, including zener diodes. 65s. net

EXPERIMENTAL RADIO ENGINEERING

E. T. A. Rapson 5th Edition

This well-known book now contains new experiments on transistors. 14s. net

from all booksellers

Pitman, Parker Street, London, W.C.2

VALUABLE FREE BOOK

Tells You How to Pass Your C. & G. Examination at First Attempt!

All Post Office personnel who are anxious to obtain early promotion should at once send for a copy of our handbook "ENGINEERING OPPORTUNITIES" which, among other intensely interesting matter, describes our unique methods of preparation for the CITY AND GUILDS EXAMINATIONS for the Telecommunication Technicians' Certificate and for individual subjects—Mathematics, Engineering Science, Engineering Drawing, Elementary Telecommunication Practice, Telecommunication Principles, Radio and Line Transmission, Telegraphy and Telephony, Line Plant Practice. It also contains details of our courses covering the G.C.E. subjects required for promotion to Assistant Engineer, Telecommunication Traffic Superintendent and other grades; and the City and Guilds examinations in Electrical Engineering Practice, the Grad. Brit. I.R.E. and A.M.S.E. Examinations, in addition to a wide range of non-examination courses in all branches of engineering—Radio and Electronics, Electrical, Mechanical, etc.

We also provide tuition for the Radio Amateurs' Examination and the P.M.G. Certificates for Radio Operators, with or without Morse training. Details are given in the handbook.

We definitely guarantee
"NO PASS — NO FEE"

If you intend to make the most of today's opportunities, you cannot afford to miss reading "ENGINEERING OPPORTUNITIES." It tells you everything you want to know to secure advancement, and describes many opportunities you may now be missing through lack of information. Send for your copy today—**FREE** and without obligation.

BRITISH INSTITUTE
OF ENGINEERING TECHNOLOGY
369 COLLEGE HOUSE,
29-31 WRIGHT'S LANE, LONDON, W.8

BIET

COMPONENTS WITH A PLUS!

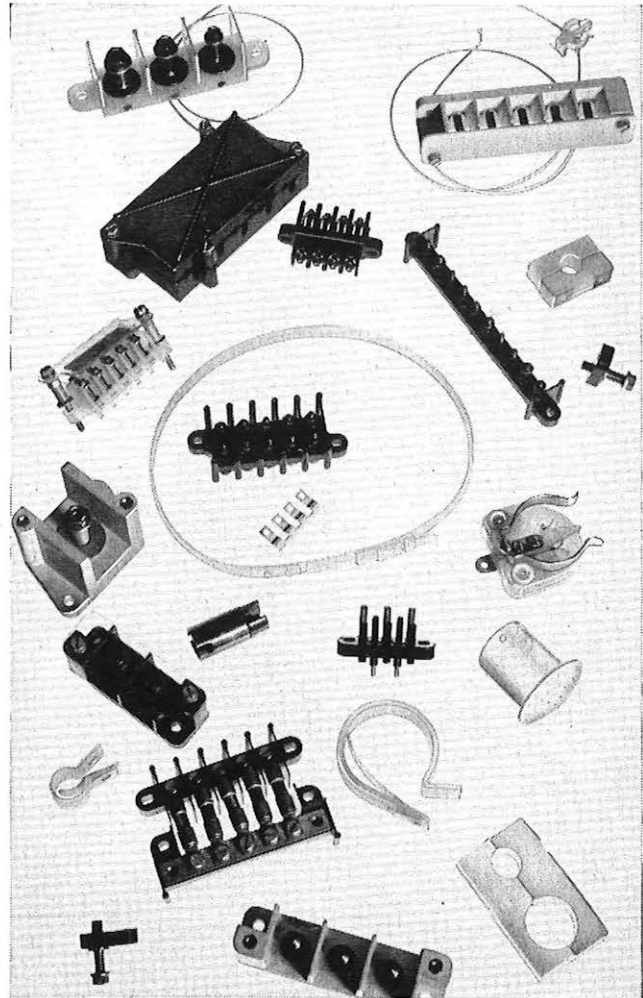

For example, terminal blocks up to 20 way, single or double row — plus non-corrodable studs and unbreakable plastic mouldings — plus acceptance of up to 8 ring terminated conductors per stud, all proof against rotational shorting — plus inter-terminal linking strips and optional covers — plus a choice of BA or unified threads with an extra choice of panel mounting, through and shrouded patterns. Not to mention six colours and numbered terminals! All this adds up to a Ward Brooke part!

Send for fuller details to Sales Department
WARD BROOKE *WB+* & CO LTD
Westbourne St., High Wycombe, Bucks. High Wycombe 4531



SILICON DIODES

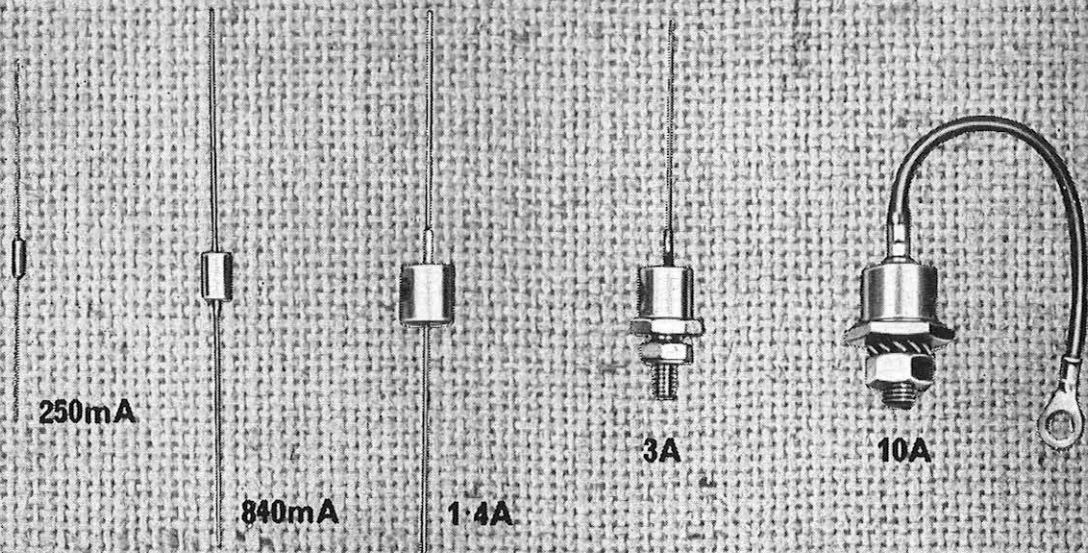

250mA to 300A
100V-1800V according to type

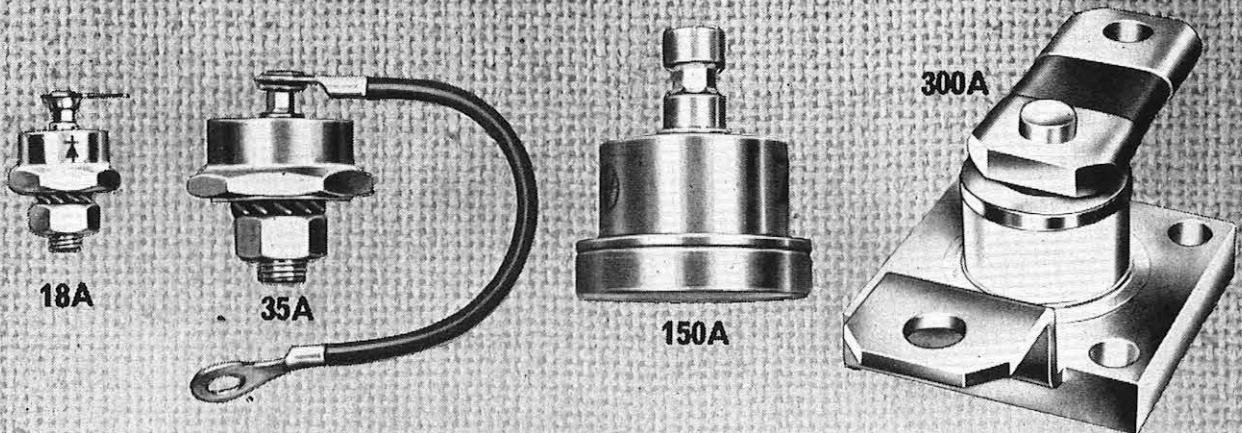

HEAT SINKS FOR POWER DIODES ALSO READILY AVAILABLE

FOR DETAILS WRITE TO DEPARTMENT **PO. S7/64**

WESTINGHOUSE BRAKE AND SIGNAL CO LTD. 82 YORK WAY, KING'S CROSS, LONDON N.1. Tel: TERminus 6432 Telex No: 2-3225

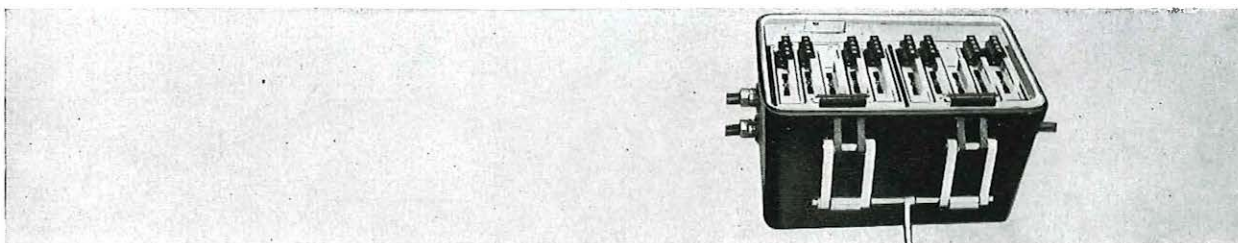
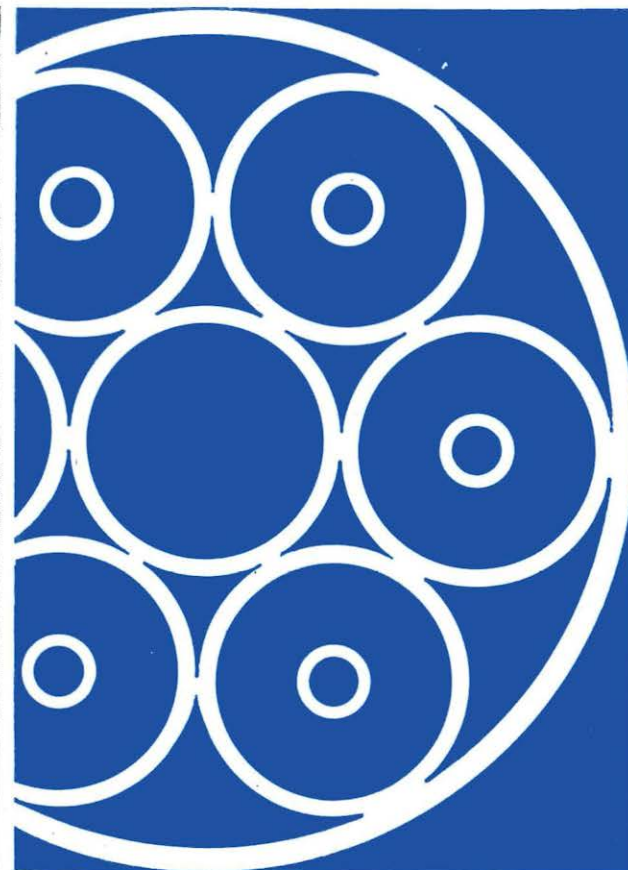

Subterranean

Subterranean is a big word which aptly describes the STC small-diameter coaxial cable system with its buried repeaters. It has eliminated the need for repeater station buildings, and considerably lowered installation and running costs. The transistorized repeaters are specially designed for installation in manholes, footway boxes and underground containers.

Attenuation changes are regulated automatically by gain control units fitted to alternate amplifiers. This STC system type LE1-A will carry up to 300 two-way speech channels (4 kc/s spacing) over one pair of coaxial tubes, and is designed to comply with proposals currently before the C.C.I.T.T. Brief technical data: Coaxial core diameter 0.174 in. (4.4 mm); Nominal repeater impedance

75 ohms at 1 Mc/s; Line frequency spectrum 60-1300 kc/s; Nominal repeater gain (at 1300 kc/s) 35db; Corresponding spacing 5.8 km (3.6 miles). Write, 'phone or Telex for leaflet C/AE38, Standard Telephones and Cables Limited, Transmission Systems Group, North Woolwich, London, E.16. Telephone ALBERT Dock 1401. Telex 21645.

world-wide telecommunications and electronics

STC

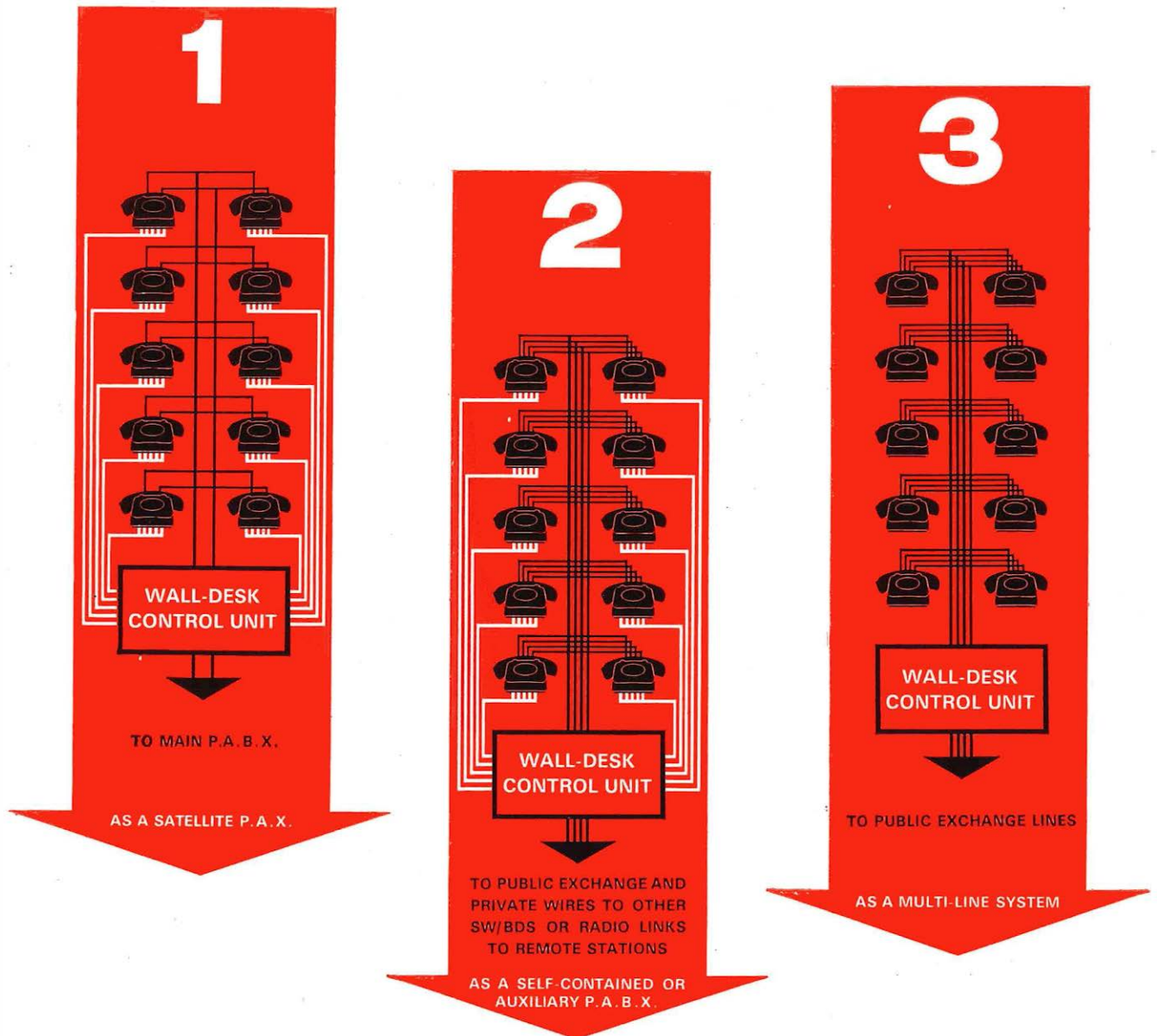

MULTIPHONE

Makes a triple attack on telecommunications problems

'Multiphone', as its name suggests, is capable of a multiplicity of applications. Serving up to 10 telephones of Plan-Etelephone type, it can be conveniently arranged by adjustment in number of circuit modules to function as a 4-line PABX, PAX or multi-line system. Its value to all administrations is increased further by its ability to work over a diversity of external circuits, so permitting a preferred arrangement to be connected as requirements demand.

Main Operational Features

- Single-digit dialling of internal calls.
- Lamp signalling and supervision of all calls signalled, held or in progress.
- Internal calls made secret or non-secret by simple strap adjustment.
- Exchange-line exclusion feature for selected stations.
- Power unit operation and continuing exchange-line service during mains failure.

For further information please apply to:—



ERICSSON TELEPHONES LIMITED
ETELCO LIMITED

A Principal Operating Company of the Plessey Group

Registered Office: 22 LINCOLN'S INN FIELDS · LONDON WC2 · Telephone HOLborn 6936

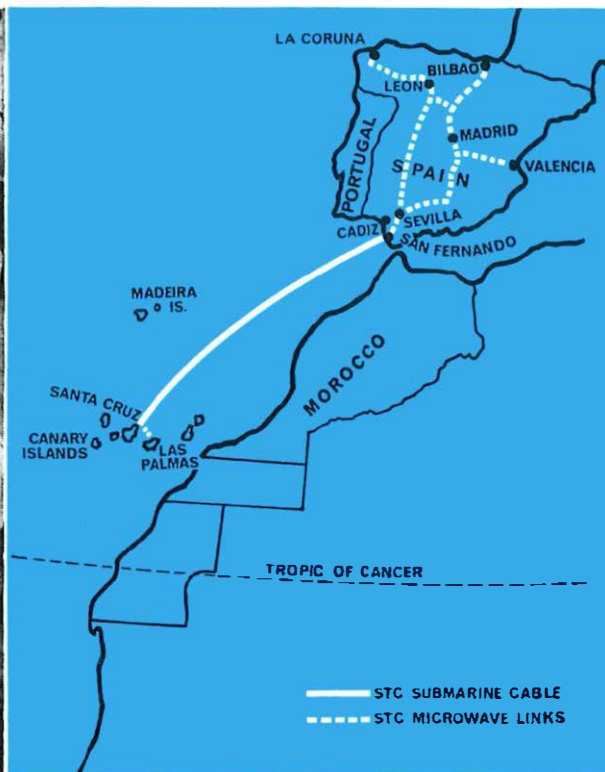
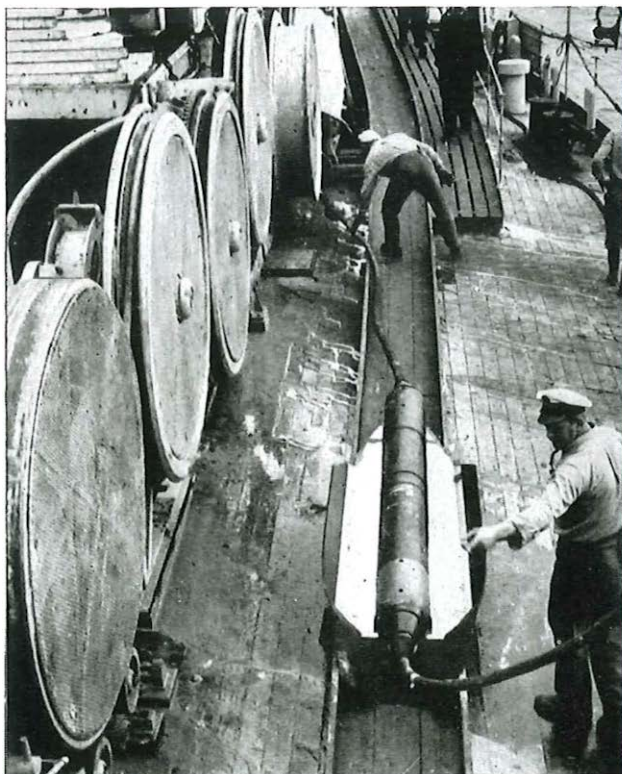

Canaries on the line

STC are to make and lay Spain's first-ever submarine telephone cable link between the Peninsula and Canary Islands. The system will be designed for 160 telephone circuits in both directions over a single cable and thus will be the highest capacity long-distance cable yet installed. This £2,500,000 order represents a key feature of Spain's major expansion in telecommunications. Laying will commence in the late spring

of 1965. Service will open in the summer. The link, measuring 750 nautical miles—710 miles of deep-sea lightweight cable and 20 miles of shallow-water armoured cable at each end—will connect San Fernando, 10 miles south of Cadiz with Santa Cruz de Tenerife. 45 STC deep-sea repeaters, 3 adjustable submarine equalizers and terminal equipment will be supplied with the cable. STC with its associated company Standard Electrica S.A., will also provide a microwave link between

Tenerife and Las Palmas which will form part of the service. High-quality speech circuits will be provided, day and night, with Europe (direct dialling to Madrid) and North America.

Standard Telephones and Cables Limited, Submarine Cable Division, West Bay Road, Southampton, Hants. Telephone Southampton 74751. Transmission Group, North Woolwich, London E.16. Telephone ALBERT Dock 1401. Telex 21645.

world-wide telecommunications and electronics

STC

G.E.C.

TELE PHONES

FOR EVERY APPLICATION



G.E.C.
706 telephone
a general purpose table instrument.



G.E.C.
711 telephone
a general purpose wall instrument.

G.E.C. also produces intercommunication sets, loudspeaking telephones and telephones for special applications for ships, railways, mines etc.



G.E.C.
710 telephone
for plan and extension systems
and special facilities.



G.E.C.
**switching
telephone**
for plan 105 and
plan 107 operation.

Telephone Division

G.E.C. (TELECOMMUNICATIONS) LIMITED • TELEPHONE WORKS • COVENTRY • ENGLAND

Works at Coventry, Middlesbrough and Treforest

Smees' 168

Model "770R" Very High Frequency receiver, covering from 19 Mc/s to 165 Mc/s in six ranges. Accepts AM, FM and CW. High sensitivity, fine control, thoroughly reliable.



Model "770U" Ultra High Frequency receiver, covering from 150 Mc/s to 500 Mc/s. Excellent performance throughout and suitable for receiving either FM or AM signals.



Model "850/2" General Purpose LF/MF receiver. Six ranges give a coverage of 10 kc/s to 600 kc/s. Full communications facilities and suitable for all climates.

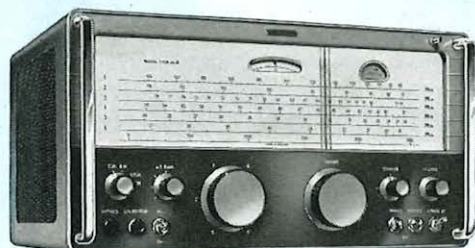

There's an

EDDYSTONE COMMUNICATIONS RECEIVER

FOR ANY FREQUENCY BETWEEN 10kc/s AND 1,000M/cs



Model 830/2 Wide Range Communications receiver. Nine ranges, 300 kc/s to 30 Mc/s. Eight spot frequency crystal controlled positions. Many refinements including incremental tuning, variable selectivity, sideband selection, crystal calibrator.



Model "880/2" High Stability HF receiver. Superb specification and performance, as necessary to meet professional requirements. Range 500 kc/s to 30 Mc/s. Sectioning accuracy within 500 c/s. Combines the advantages of crystal control with continuous tuning.

Model "770S" Extra High Frequency receiver, with coverage from 500 Mc/s to 1000 Mc/s. Coarse and fine tuning controls permit excellent frequency resolution. High performance and possesses many special features.



Please write for full Technical Specifications to the Manufacturers

STRATTON & CO. LTD., BIRMINGHAM, 31

Telephone: PR10ry 2231/4

TELEX: 33708

RL6B MICROWAVE RADIO LINK

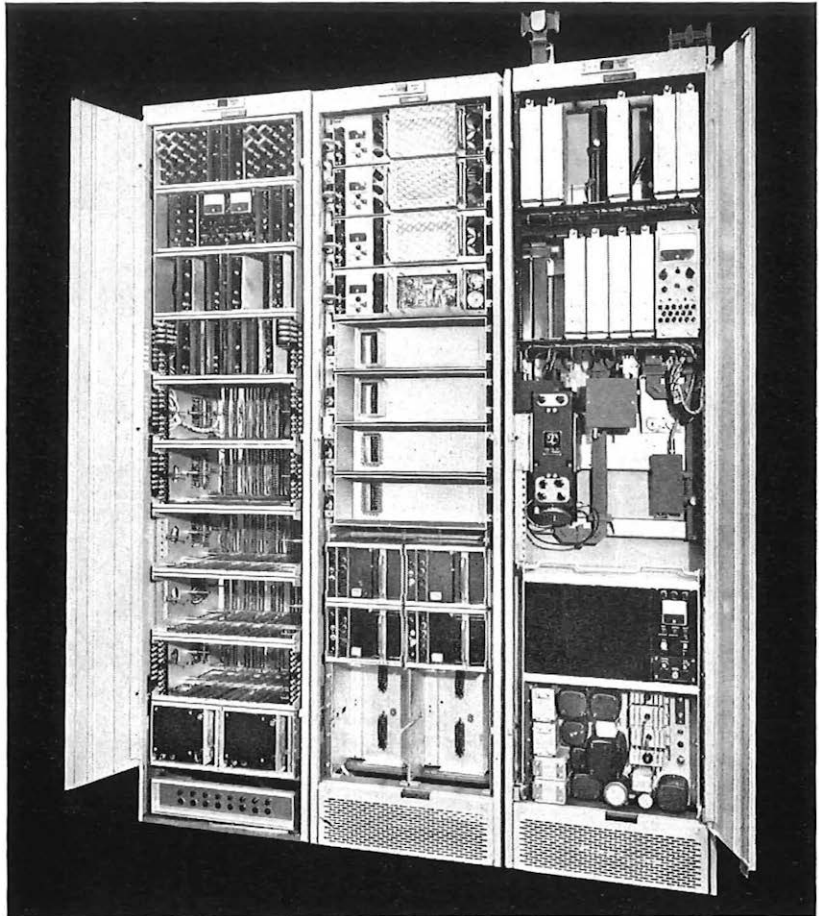

1800 TELEPHONE CIRCUITS/MAXIMUM TRANSISTORIZATION A new 6Gc/s microwave transmission system, the RL6-B, can transmit 1800 telephone channels or colour T.V. plus sound per radio channel. Designed to use the C.C.I.R. frequency plan, it will provide up to 8 broadband radio channels on one route. Maximum use of transistors, high performance level, and all-round operational economy are the essential features of the RL6-B. By extensive prefabrication, and simplification of space and installation requirements, considerable savings in commissioning time and a lower overall cost have been achieved. Systems for mains and battery operation can be supplied and a 960 telephone circuit version is also available for lower density traffic routes. The main features of the RL6-B system are: 8 broadband radio channels C.C.I.R. performance 10 watt output power from periodic permanent magnet focusing TWT Transistorized throughout except TWA and the modem cubicle 960 telephone circuit version also available Switching systems available for N + 1 or 2 protection channels Aerials and towers can be supplied All solid state narrow-band auxiliary link Cassegrain antenna for single or bi-polar operation. Write, 'phone or Telex to: Standard Telephones and Cables Limited, Transmission Systems Group, North Woolwich, London, E.16. Telephone ALBERT Dock 1401. Telex 21645.

world-wide telecommunications and electronics

STC

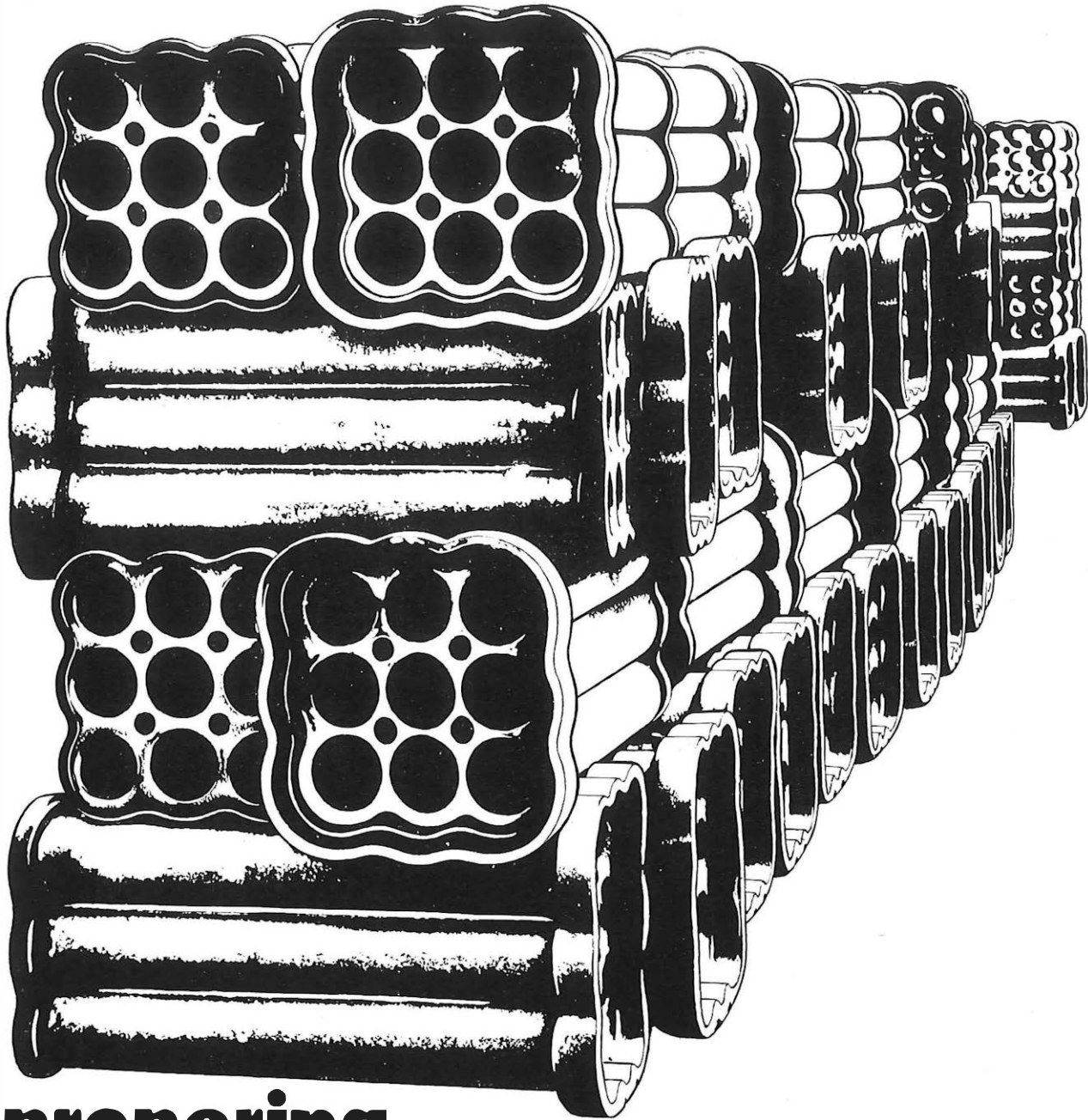

preparing for **SOUND COMMUNICATIONS**

The safe and constant conveyance of our vital communications is ensured by the permanence of **glazed vitrified clay conduits**. With a load capacity of up to 1,000 messages at a time for a nine-way conduit, the choice of an enduring protective outer casing for electric cables, below ground, is of first importance to the Engineer.

**NATIONAL SALT GLAZED PIPE
MANUFACTURERS' ASSOCIATION**
125 New Bond Street, London, W.1





The world's most competitive Single Sideband Radiotelephone — the SSB 125 is suitable for fixed or mobile operation and is the most economic equipment for long distance communication available today.

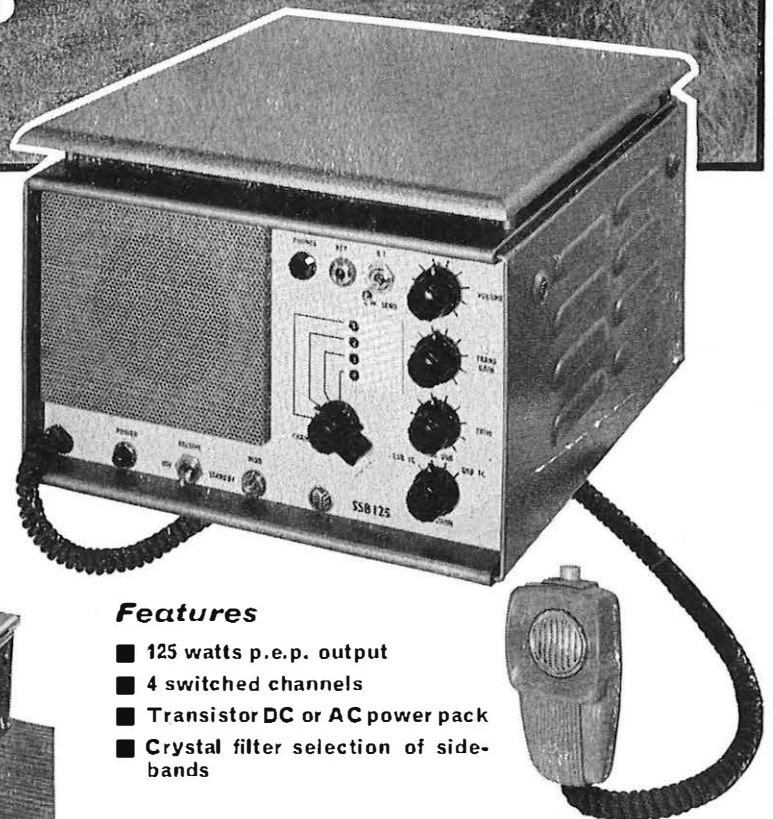

Features

- 125 watts p.e.p. output
- 4 switched channels
- Transistor DC or AC power pack
- Crystal filter selection of sidebands



PYE TELECOMMUNICATIONS LTD.
CAMBRIDGE · ENGLAND

Telephone: Teversham 3131

and **Now-**
a Fully Transistorised
Walkie-Talkie!

the **PYE** **Bantam**
 TWO-WAY RADIOTELEPHONE



*Once again in
 the tradition of
 the outstanding
 Cambridge and
 Vanguard Radio-
 telephones, Pye
 have produced the
 Bantam, a brilliant
 fully transistorised
 Walkie-Talkie.*

- Fully transistorised Transmitter and Receiver
- Long endurance with Rechargeable or Dry Batteries
- Reliability and accessibility of components
- Lightweight 4 lbs. (1.82 kg.)
- Crystal Filter selectivity
- Very high performance Receiver
- Frequency Band 25-174 Mc/s.
- Weatherproof

PYE TELECOMMUNICATIONS LTD. CAMBRIDGE, ENGLAND · Telex No. 81166

YOU COULD
NOT WALK
THE NUMBER
OF MILES
OF CABLE
SHEATHED IN



HIGH DENSITY
POLYETHYLENE
WITHOUT
FEELING very, very tired!

Use the post to find out more about
the range of Rigidex cable grades.
Please quote (Ref. 328)

Rigidex is a reg'd trade mark of British Hydrocarbon Chemicals Ltd and one of the products they manufacture at Crangemouth.
Sole Selling Agents

British Resin Products Ltd

A COMPANY IN DISTILLERS CHEMICALS AND PLASTICS GROUP



SALES AND TECHNICAL SERVICE DEVONSHIRE HOUSE PICCADILLY W1 HYDE PARK 8131

Distillers Plastics Serve Everyman

COMBINED TAPE AND EDGE CARD READER

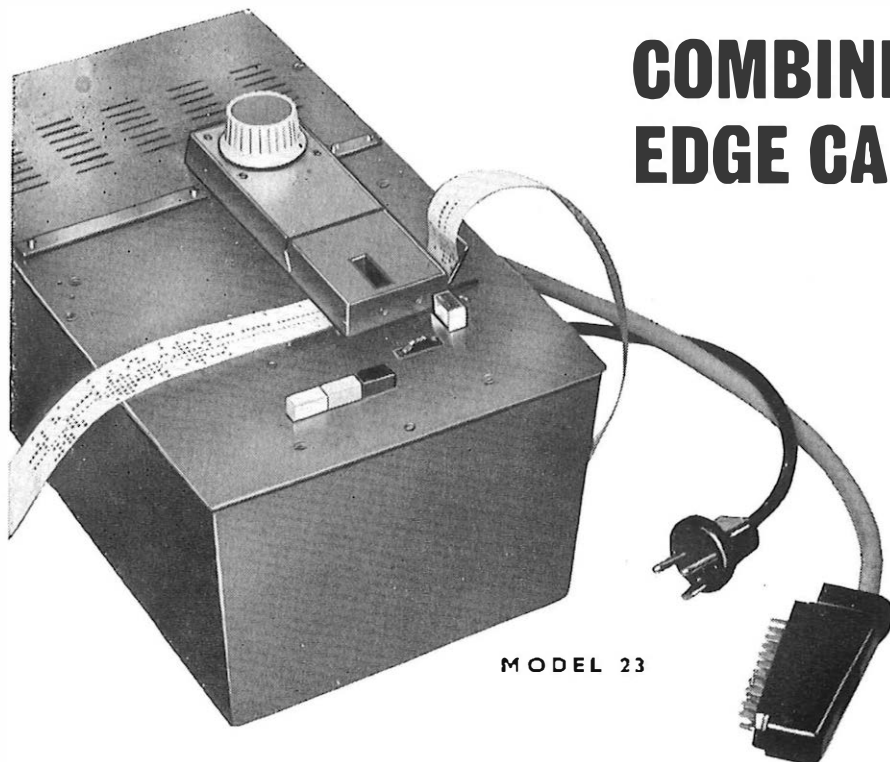

MODEL 23

- 5, 6, 7, 8 unit reading of tape and edge card
- Tight tape, tape out, tape latch alarms
- Unlimited manual forward and back-spacing of tape and card
- Free standing or flush mounting in a desk unit
- Signal contacts made for 95% of each reading cycle



GREAT NORTHERN TELEGRAPH WORKS

SYDHAVN'S PLADS 4, COPENHAGEN S.V. DENMARK

LONDON OFFICE: 5 ST. HELENS PLACE, LONDON, E.C.3

TEL: LONDON Wall 4567

ANOTHER STEP **FORWARD** . . .

An IMPROVED AVOMETER

Model **8** Mk III

- Fused ohms circuit provides increased protection against inadvertent overload.
- Improved temperature coefficient over whole range. With the aid of a range of d.c. shunts measurements can be made up to 400 amps d.c.



Regd. Trade Mark

This new model incorporates increased sensitivity in the lower AC ranges and wide frequency characteristics, with the traditional AvoMeter features including the AVO automatic cut-out mechanism and interlocking rotary switches for quick range selection.

Write for fully descriptive Folder or for complete Catalogue of AVO Instruments.



**Designed for
Dependability**

AVO LTD AVOCET HOUSE, 92-96 VAUXHALL BRIDGE ROAD, LONDON, S.W.1. Telephone: VICTORIA 3404 (12 lines)



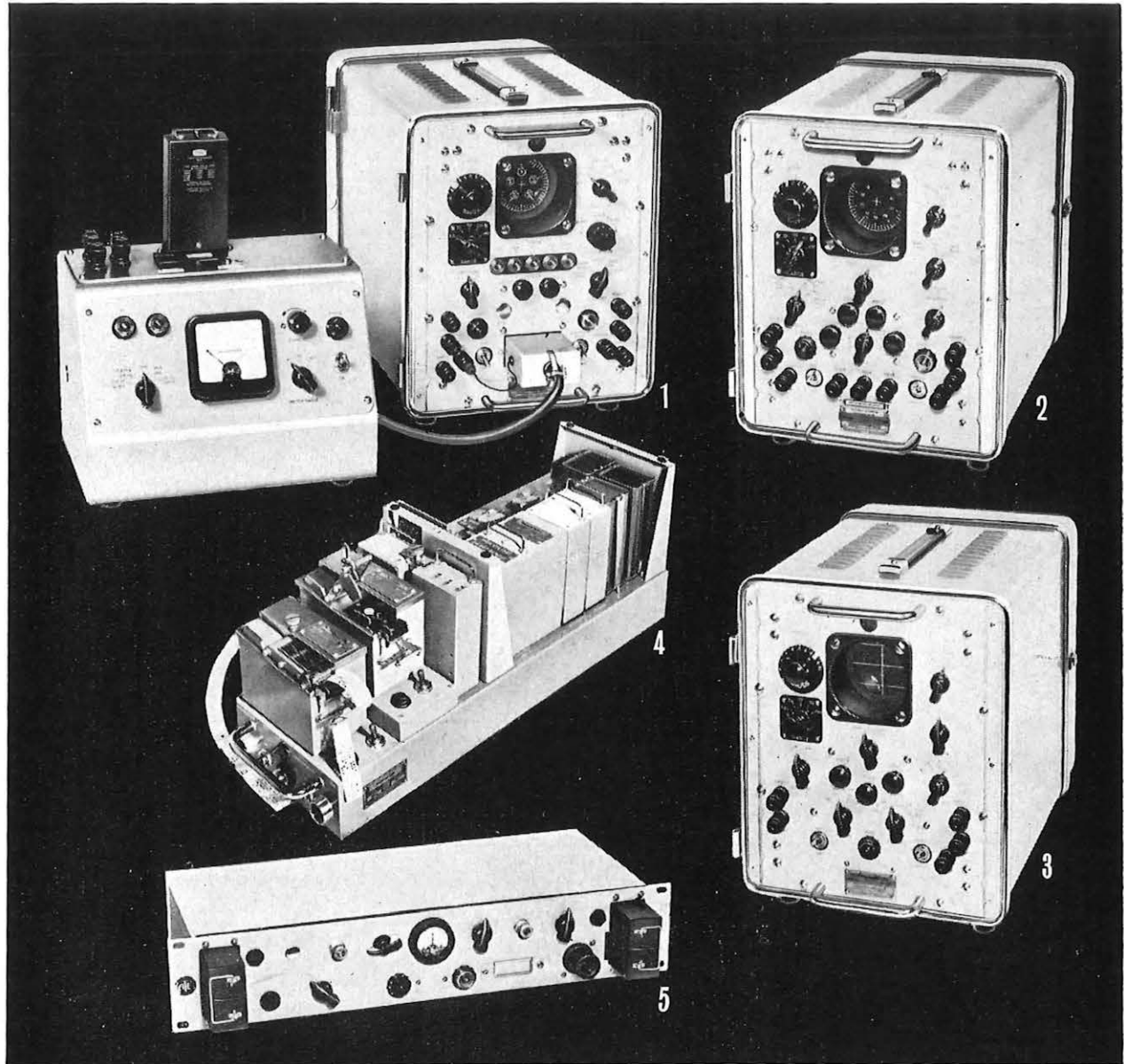

TELEGRAPH EQUIPMENT—FOR TRANSMITTING AND TESTING

ATE equipment for telegraph transmission and test purposes is in use all over the world — and not by chance. First, AT&E had to prove itself — which is why, today, ATE equipment is chosen by Postal, Military, Airline, Railway and other authorities. By all large users of telegraph systems, in fact. It is the comprehensiveness, no less than the outstanding technical quality of ATE Telegraph Equipment, which has given it this world-wide reputation. Within the range of ATE Telegraph Equipment, the various units include: 1. Telegraph Distortion Measuring Transmitter with Relay Test Adaptor 2. Distortion Measuring Receiver 3. Telegraph Signal Display 4. Tape-reader Auto-number Sender and 5. Transistorised Synchronous Regenerative Repeater. We will gladly supply details.

Please write to: A T & E (BRIDGNORTH) LIMITED · Bridgnorth · Shropshire · England
Automatic Telephone & Electric Company Limited · A Principal Operating Company of the Plessey Group



G.E.C.
SHF
 radio link
 now
 operating
 in
 Malaya

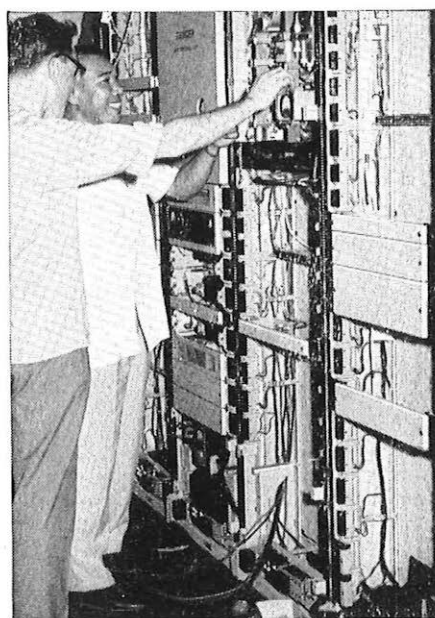
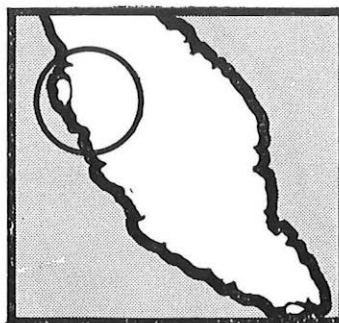
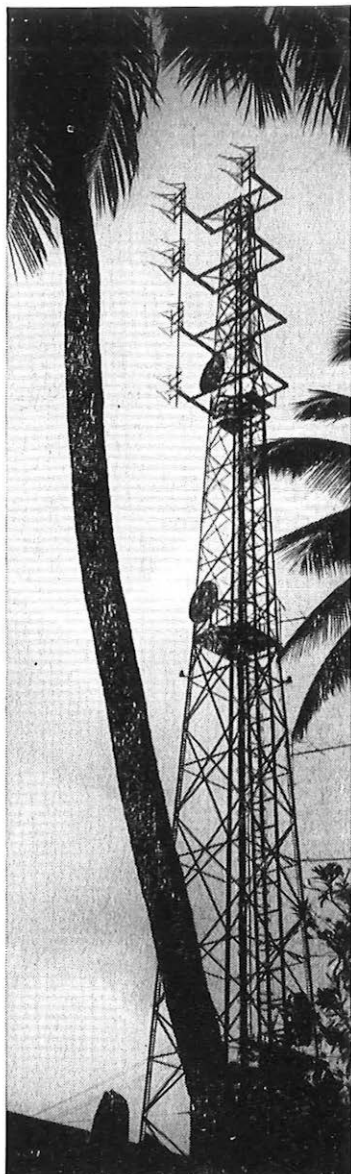

The microwave radio link between Penang and Gunung Kledang (near Ipoh) in Malaya is now in operation. The link consists of the two terminal stations with an intermediate repeater station at Maxwell's Hill. The link uses G.E.C. radio equipment operating in the 6Gc/s frequency band, supplied under a contract awarded to the Company by the Crown Agents for Oversea Governments and Administrations on behalf of the Telecommunications Department, Malaya.

The 50 mile path between Maxwell's Hill and Penang employs dual space diversity in order to achieve a high propagation reliability.

The system is equipped with a main and a protection radio channel in each direction of transmission with automatic switching in the event of failure of the working radio channel. The switching equipment is arranged so, that in the future, additional RF. channels can be added and these will utilise the one protection channel already provided.

In addition to the broadband radio equipment, the route is equipped with an auxiliary S.H.F. link for conveying engineer's speaker circuits and remote controls and alarms. This narrow band SHF channel is multiplexed together with the main channels for connection to the same paraboloid antenna.

The consultants for this contract are Messrs. Preece, Cardew and Rider.

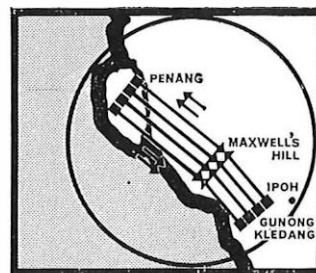

KEY
 ■ Terminal
 ◆ Repeater

EVERYTHING FOR TELECOMMUNICATIONS

For further information please write for Standard Specification SPO 5555

Transmission Division

G.E.C. (TELECOMMUNICATIONS LTD)
 Telephone Works · Coventry · England

Works at Coventry, Middlesbrough and Treforest



These are designed and manufactured to meet C.C.I.T.T. recommendations or any other specific requirements. They are the products of modern plant, specialist engineers and over sixty years of experience—backed by extensive research and development facilities. BICC undertake the manufacture and installation of cables for every type of telecommunication system anywhere in the World.

BICC

TELEPHONI

Technical information on BICC Telephone Cables is contained in our publications—freely available to Telephone Administrations.

BRITISH INSULATED CALLENDER'S CABLES LIMITED
International Sales Office:

21 BLOOMSBURY STREET LONDON WC1 ENGLAND
Branches and Agents throughout the World.

QUAD TRUNK CABLE

This cable, manufactured to a British Post Office specification, is produced in large quantities for audio frequency junction circuits. In common with other types of cable, they can be made to comply with any national or private specification.



TYPE 375 COAXIAL CABLE

For television circuits and multichannel telephony, BICC manufacture cables containing coaxial pairs meeting the C.C.I.T.T. recommendation G.334. These can be combined with symmetrical pairs for audio frequency or short-haul carrier circuits.

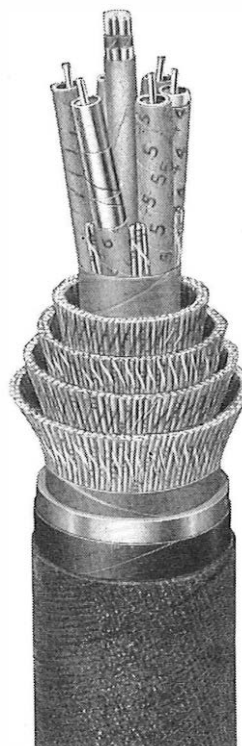

POLYTHENE INSULATED DISTRIBUTION CABLE

Because of their ease of installation, reliability and low cost, polythene insulated distribution cables are widely used, particularly in sizes up to 100 pairs. They may be installed underground or, as in the case of the type illustrated, used with an integral suspension strand wherever aerial installation is preferred.

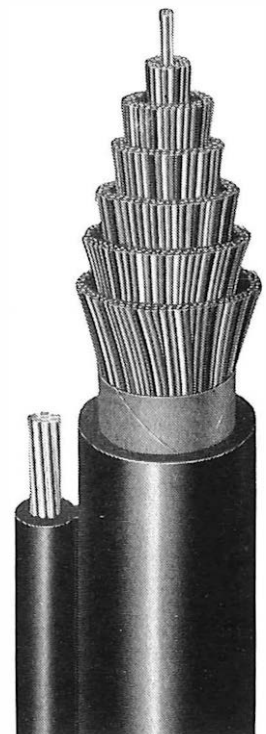

CABLES

UNIT TWIN CABLE

Large cables of unit construction are specially suited to the systematic arrangement of a dense telephone subscriber network. Units of 50 or 100 pairs are first assembled, then the required number of units are combined and sheathed to form the complete cable.



AEI with world-wide experience in communications and well-known for its contribution to the success of CANTAT B and COMPAC in the Commonwealth Cable Link, introduces a further addition to its range of carrier transmission equipment.

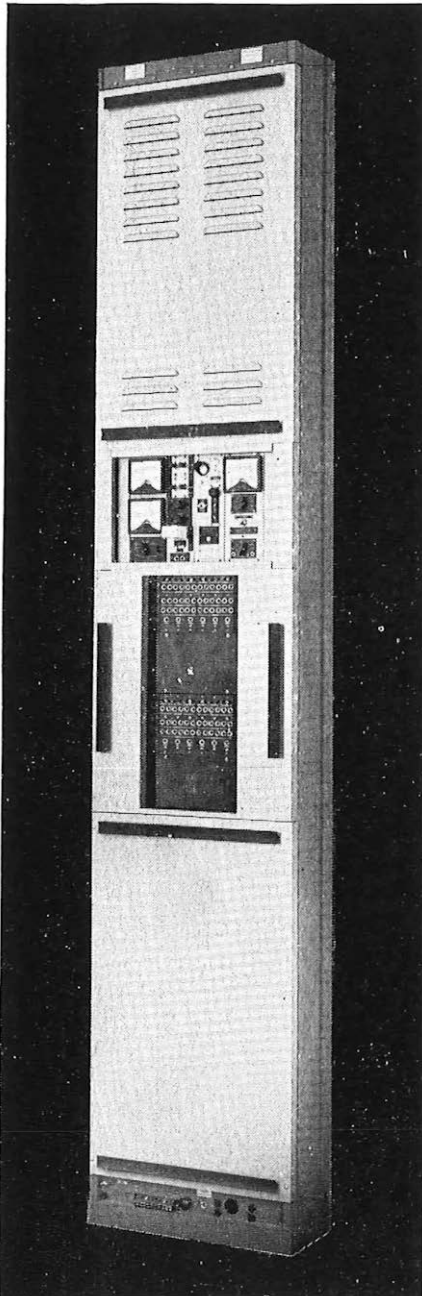
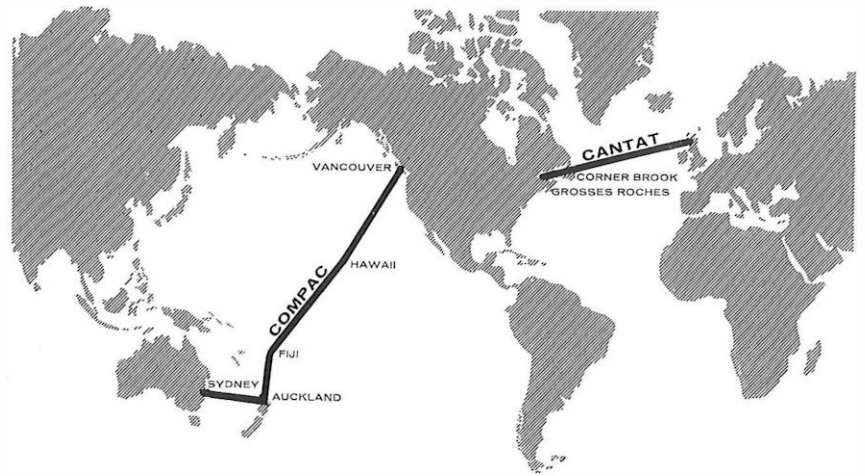

AEI Transistorised FMVFT

TYPE CT 24A

For the provision of teleprinter or data transmission circuits.

Minimum space... Minimum maintenance...
Minimum power consumption...

- * CCITT standards of performance
- * 24 channels per rackside
- * 50 baud nominal, with operation up to 80 bauds
- * Plug-in units
- * Pilot facility 300 c/s or 3300 c/s
- * Optional in-built test equipment comprising:
 - a) Telegraph test set
 - b) Level measuring set
 - c) Frequency check unit
- * Completely self contained with all power supplies.

24 frequency modulated channels are provided in the nominal frequency band 420-3180 c/s with 120 c/s separation between adjacent channels. These are built up from 4 sub-groups of 6 channels each in the frequency band 1140-1740 c/s.

Compactly assembled plug-in units use printed circuit wiring boards with small encapsulated filter and transformer units. Equipment is protected by bay covers, but test equipment and jackfields are directly accessible at centre of rack.

Details of the latest AEI Carrier Telephone and Telegraph Equipment supplied on request.

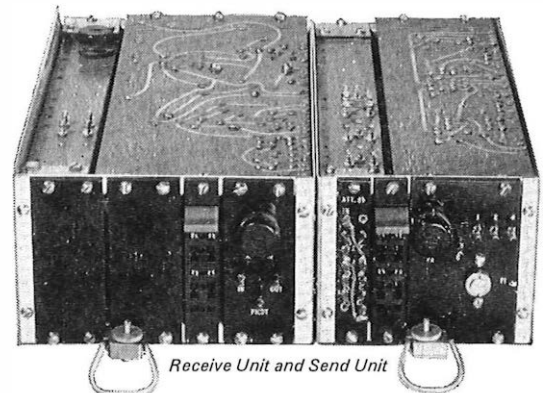

AEI

COMMUNICATIONS

ASSOCIATED ELECTRICAL INDUSTRIES LTD
TELECOMMUNICATIONS TRANSMISSION DEPARTMENT
WOOLWICH · LONDON SE18

TAKE FIVE!

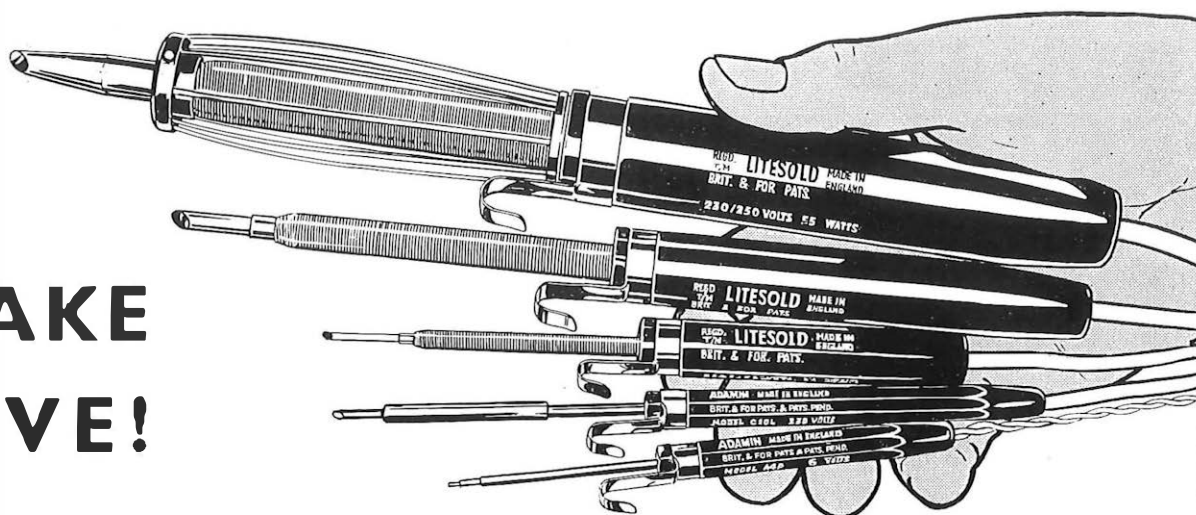

There are 30 other models, too. There ARE several other makes of soldering instruments. Big ones. Small ones. Good ones. We've seen them. We don't make the biggest ones. Or the most expensive ones. Or the most elaborate ones. We DO make the smallest ones. And the widest range. We make the best. Always have. May we send you details?

Brochure P.D. 34 post free on request

LIGHT SOLDERING DEVELOPMENTS LTD., 28 Sydenham Road, Croydon, Surrey. Tel.: CRO 8589

Ernest Turner

Electrical Measuring Instruments

Ideally matching contemporary panel design, the Ernest Turner Model 703, illustrated here, is enhanced by the flush-fitting surround. A high degree of accuracy is adequately supported by the easy-to-read scale and clean dial layout. Full details of the range of rectangular electrical measuring instruments and flush mountings are contained in Leaflets 85/G and 85/AF, available on request.

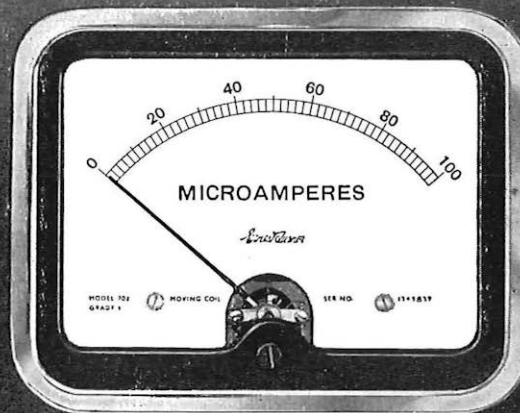

Ernest Turner Electrical Instruments Ltd
HIGH WYCOMBE · BUCKINGHAMSHIRE · ENGLAND

SECURELY SEALED with

DENSO MASTIC

Cold applied and non-hardening, DENSO Mastic is ideal for sealing cable entries into exchanges and similar applications. Due to its fibrous bonding it is self-supporting and will not crack. Its many uses include the temporary plugging of spare ducts, electrical gland and joint-box filling, sealing of large and irregular apertures, etc.

DENSO Mastic is impervious to water and gas and can be used for sealing, plugging and caulking above ground, below ground and under water.

For full details of the DENSO SERVICE, contact



24½" diameter cables passing through duct measuring 36" × 18" × 9" which is completely filled with DENSO MASTIC.

WINN & COALES LTD. Denso House, Chapel Road, London, S.E.27.
Also at Manchester, Belfast and Dublin. Agents throughout the Commonwealth. Tel: GIPsy Hill 7511



T.C.C. introduce an entirely new range of etched aluminium foil Capacitors for operation over a temperature range of -55° to 125°C, and for working between 6 to 150V. D.C.

In performance, these new Capacitors approach the tantalum foil type, and will meet a similar specification. Their electrical characteristics remained stable during life tests of over 2,000 hours at 125°C. They provide a low cost alternative to tantalum Capacitors for many applications.

SCORES AGAIN!



FIRST EVER ETCHED ALUMINIUM



ELECTROLYTIC TO OPERATE AT 125°C



For full details of this latest T.C.C. achievement please write for a copy of Technical Bulletin No. 100

THE TELEGRAPH CONDENSER CO. LTD.

(Head Office and Works) North Acton, London, W.3

Telephone: ACOrn 0061

Telex: 261383

(Also at) Chessington, Surrey • & Bathgate Scotland



RECTIFIER EQUIPMENTS FOR ALL
TELECOMMUNICATION
APPLICATIONS

PLEASE WRITE AND GIVE DETAILS OF YOUR PARTICULAR APPLICATION
TO P●.E7/64 RECTIFIER DIVISION, EQUIPMENTS DEPARTMENT
WESTINGHOUSE BRAKE AND SIGNAL CO LIMITED
82 YORK WAY · KING'S CROSS · LONDON N1 · TERMINUS 6432 · TELEX No. 2-3225

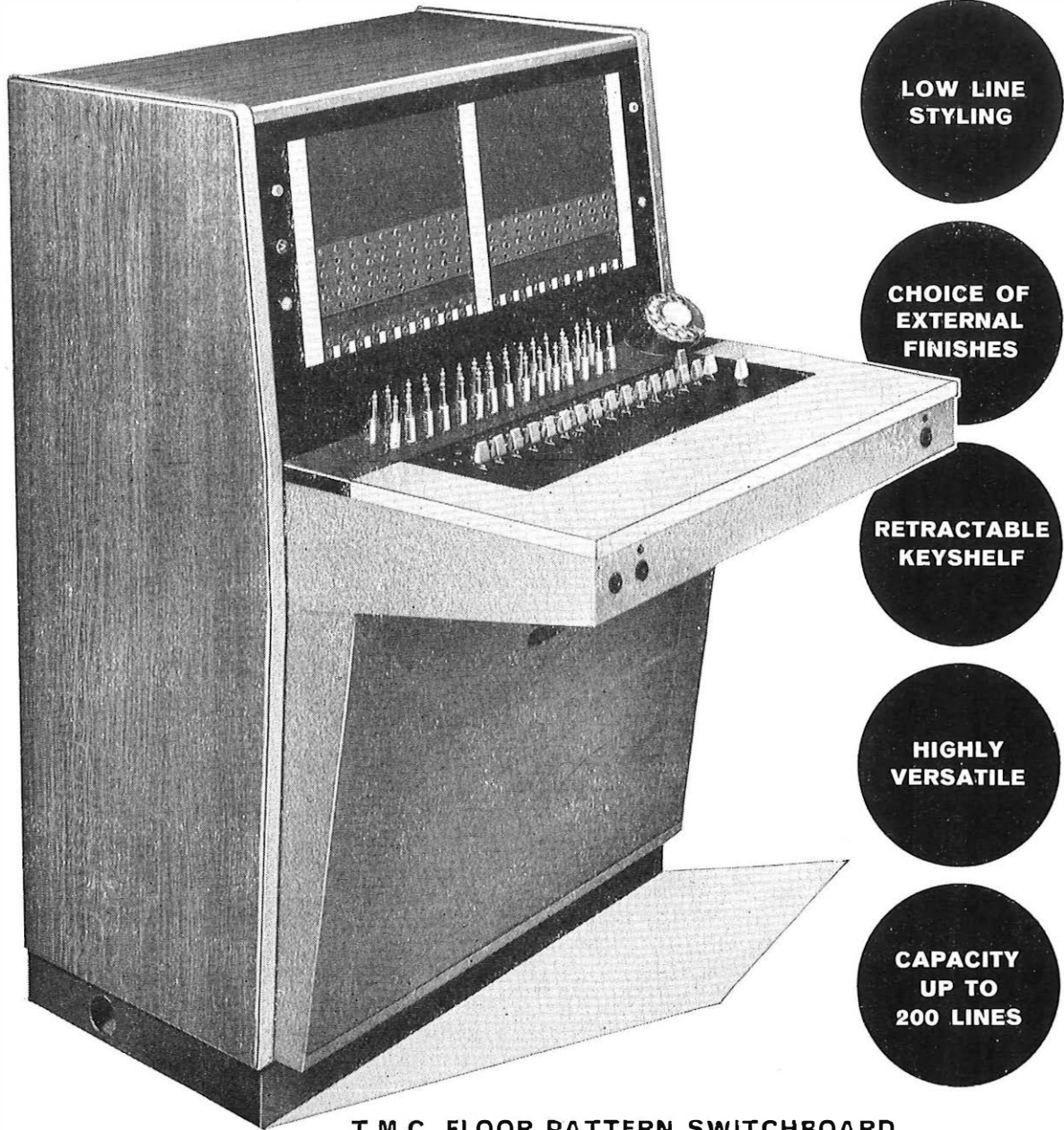

T.M.C. FLOOR PATTERN SWITCHBOARD

“A thing of beauty”

Leading industrial designers, top circuit engineers, and a production team with years of accumulated switchboard experience have worked together to evolve this superb TMC switchboard. The result is a product which in appearance and performance will fulfil the needs of many years to come. It will blend with the decor of the most modern office or reception hall. It is highly adaptable and can be variously equipped, as a multiple or non-multiple. This switchboard will serve subscribers, operators and engineers throughout a long working life — and serve them well.



TELEPHONE MANUFACTURING COMPANY LIMITED

Telephone Equipment Division • Public Equipment Unit • Martell Road
West Dulwich • London • S.E.21 • Telephone GIPsy Hill 2211 • Telex 28115

A MEMBER OF THE  GROUP OF COMPANIES

MALAYAN STD NETWORK EXPANDS USING G.E.C. EQUIPMENT

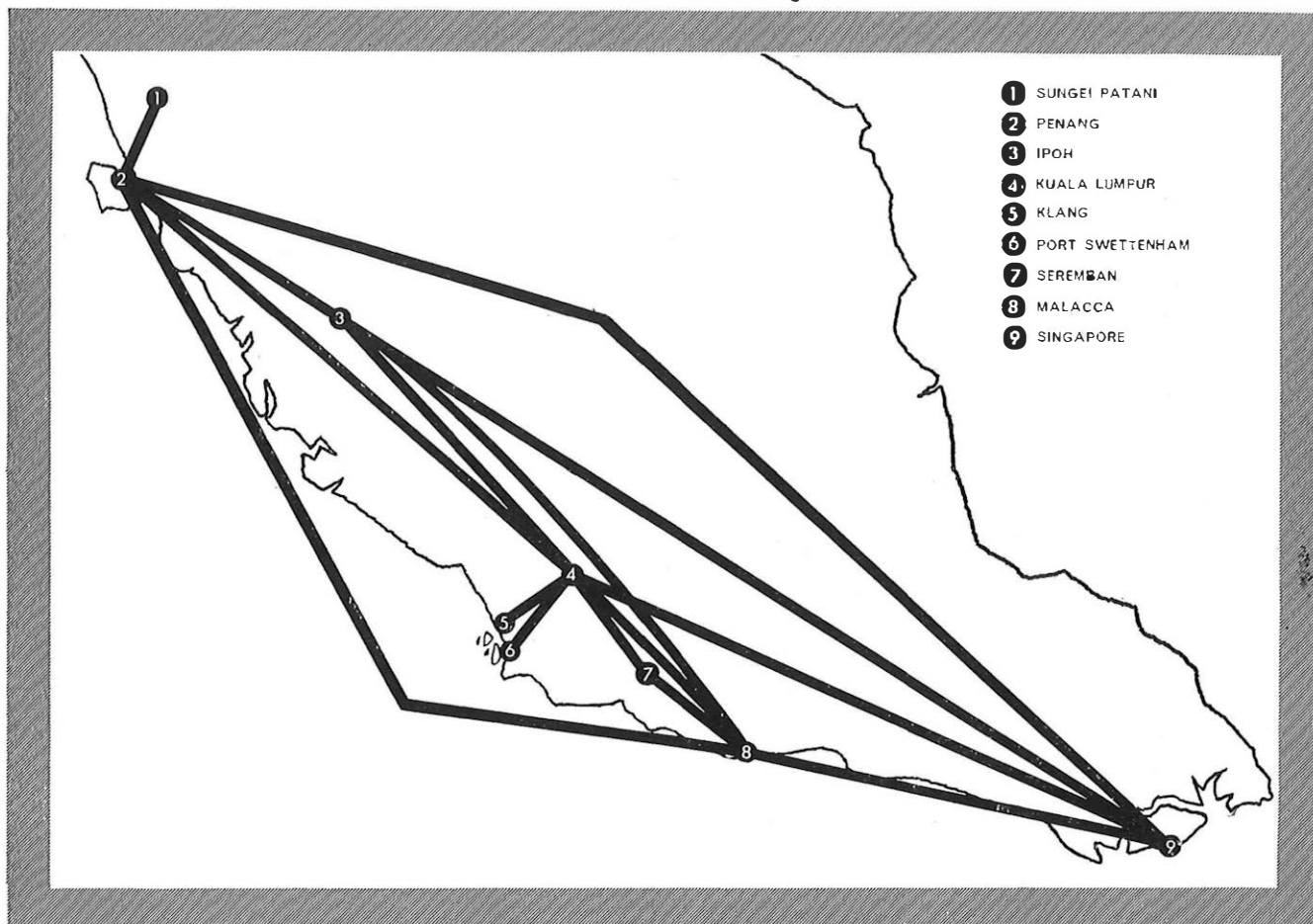

Malaya's Telecommunications Department is going ahead fast with the modernisation and expansion of its services. Subscriber Trunk Dialling, already operating in Klang, Kuala Lumpur, Malacca, Port Swettenham, Seremban and Singapore, has now been extended northwards to Ipoh, Penang and Sungei Patani. The inaugural call at Ipoh was made on April 11th of this year by the Minister of Works, Dato V. T. Sambantham.

In all these exchanges, the S.T.D. equipment was supplied by G.E.C. In addition, G.E.C. supplied the microwave radio link over which all calls to Penang via Ipoh are routed.

Another important addition to the Malayan S.T.D. network is the new automatic telephone exchange at Sungei Patani, officially opened on 22nd March by Y.T.M. Tengku Abdul Rahman Putra Al-Haj, Prime Minister of Malaysia. This is a 600-line multiple auto-manual exchange that serves the rural area round Sungei Patani, with seven dependent rural automatic exchanges. The exchange is housed in a fine new building, and replaces a 10-position manual board—a sign of the times in modern Malaya.



(1) Prime Minister of Malaysia unveils a plaque to commemorate the opening of the new exchange at Sungei Patani.
(2) Commissioning the new exchange at Sungei Patani.

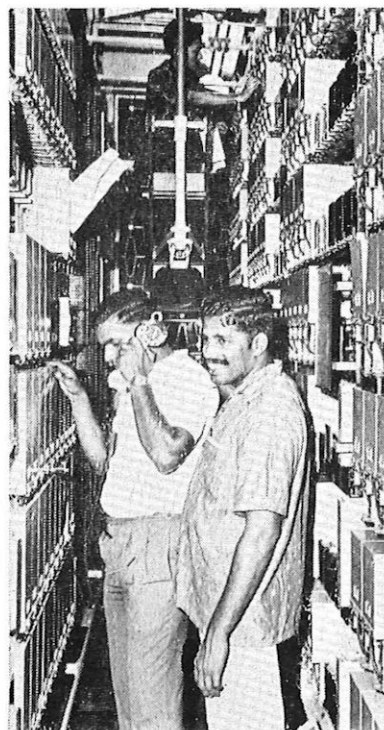

everything for telecommunications

Public Exchange Division
G.E.C. (Telecommunications) Ltd, Telephone Works, Coventry, England

SP.1

INDEX TO ADVERTISERS

	PAGE		PAGE
Adcola Products, Ltd.	3	Newnes, George, Ltd.	3
Associated Electrical Industries, Ltd.	34	Oxley Developments Co., Ltd.	5
Automatic Telephone & Electric Co., Ltd.	16, 30	Pirelli General Cable Works, Ltd.	2
Avo, Ltd.	29	Pitman, Sir Isaac, & Sons, Ltd.	17
British Institute of Engineering Technology	17	Pye Telecommunications, Ltd.	26-27
British Insulated Callender's Cables, Ltd.	32-33	Rootes Tempair, Ltd.	7
British Resin Products, Ltd.	28	Standard Telephones & Cables, Ltd. 9, 12, 14, 19, 21, 24, 41, 42	
Ericsson Telephones, Ltd.	15, 29	Stratton & Co., Ltd.	23
G.E.C. (Telecommunications), Ltd.	10-11, 22, 31, 39	Submarine Cables, Ltd.	1
Great Northern Telegraph Co., Ltd.	29	Telegraph Condenser Co., Ltd.	36
Hubbell, Harvey, Ltd.	7	Telephone Cables, Ltd.	6
Iliffe Books, Ltd.	5	Telephone Manufacturing Co., Ltd.	4, 38
Light Soldering Developments, Ltd.	35	Turner, Ernest, Electrical Instruments, Ltd.	35
Marconi Co., Ltd., The	8	Ward Brooke & Co., Ltd.	17
Mullard, Ltd.	13	Westinghouse Brake & Signal Co., Ltd.	18, 37
National Salt Glazed Pipe Manufacturers' Association	25	Whiteley Electrical Radio Co., Ltd.	5
New Era Publishing Co., Ltd.	40	Winn & Coales, Ltd.	36

MODEL ANSWER BOOKS

CITY AND GUILDS OF LONDON INSTITUTE
TELECOMMUNICATION TECHNICIANS' COURSE

TELECOMMUNICATION PRINCIPLES A

TELECOMMUNICATION PRINCIPLES B

ELEMENTARY TELECOMMUNICATION PRACTICE

Price 7s. 6d. each. Post Paid 8s.

The following model answer book, although published for the old Telecommunications Engineering Course, is still useful and is offered at a considerably reduced price.

TELEPHONE EXCHANGE SYSTEMS I (Telephony and Telegraphy A, Telephony B)

Price 2s. each. Post Paid 2s. 6d.

Orders to
The Post Office Electrical Engineers' Journal
G.P.O., 2-12 Gresham Street, London, E.C.2

NEW ERA BOOKS

TELEPHONY

J. ATKINSON

Known to all as the standard textbook on Telephony, this work packs a wealth of essential information into its two large volumes. More than fifteen hundred illustrations amplify the clear explanations of the text, which, besides covering the City and Guilds syllabus, has a lasting value for reference purposes.

TELEGRAPHY

J. W. FREEBODY

Indispensable as a work of reference for both students and engineers, 'Telegraphy' gives a clear exposition of theory and principles underlying practical equipment, as well as detailed information about the equipment used by the G.P.O. for telegraphy and telex services.

TELECOMMUNICATIONS PRINCIPLES

R. N. RENTON

'Telecommunications Principles' is intended to meet the requirements of the City and Guilds Examinations in the subject at Grades I, II, and III. It contains all the basic, essential details of electrical and magnetic theory needed by the student of telephony, telegraphy, or radio and television. Worked examples show the application of these fundamental principles to practical calculations.

Write today for full details of these books and of the New Era system of easy-payment purchase to:—

**NEW ERA PUBLISHING CO. LTD., Dept. A3,
45 New Oxford Street, London, W.C.1**

62 TYPE

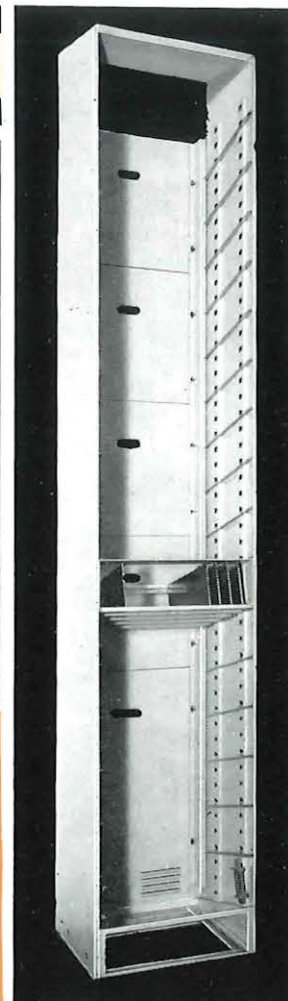
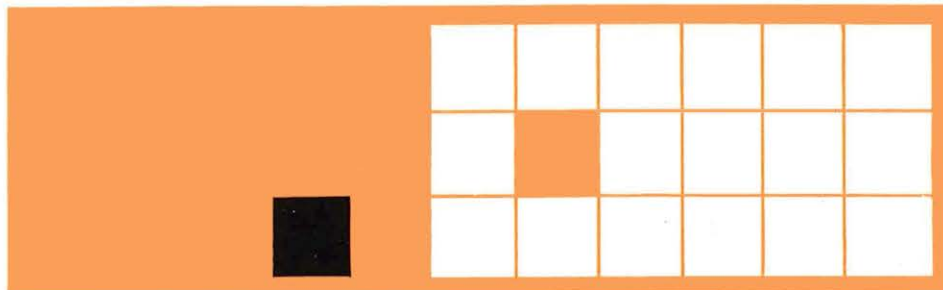
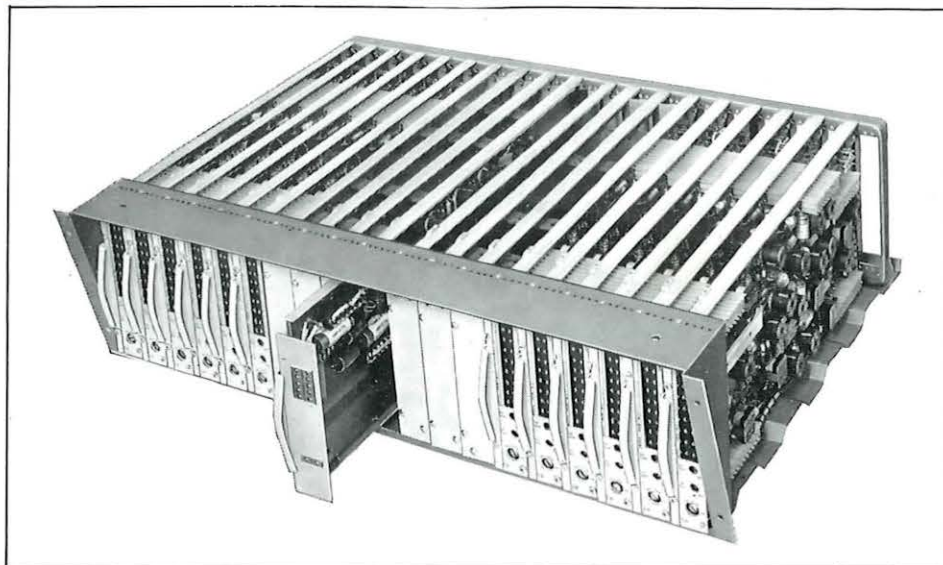

SHELF UNIT CONSTRUCTION/FLEXIBILITY IN EQUIPMENT LAYOUT

The shelf unit construction of the 62-type transmission multiplex equipment combines the compactness of modern equipment design with ease of installation and maintenance. The 450 mm deep racks are compatible with double-sided racks in existing installations which have the C.C.I.T.T. recommended depth. The design, which has been accepted as standard by the British G.P.O., gives maximum concentration of transistorized units in the rack space, yet with easy access from the rear to all wiring connexions. Soldered connexions in the station wiring are reduced to the minimum possible. Miniaturized components are mounted on well-screened plug-in printed circuit boards which by a simple extension device can be inspected and tested in their working positions. Reduction in equipment heat dissipation and improved ventilation avoids high equipment temperatures and gives more reliable performance. 62-type shelf units are supplied as factory wired and tested units which allow a high degree of flexibility in equipment layout and extensions. For further information write, 'phone or Telex: Standard Telephones and Cables Limited, Transmission Systems Group, Marketing Department, North Woolwich, London, E.16. Telephone ALBERT Dock 1401. Telex 21645.

world-wide telecommunications and electronics

STC

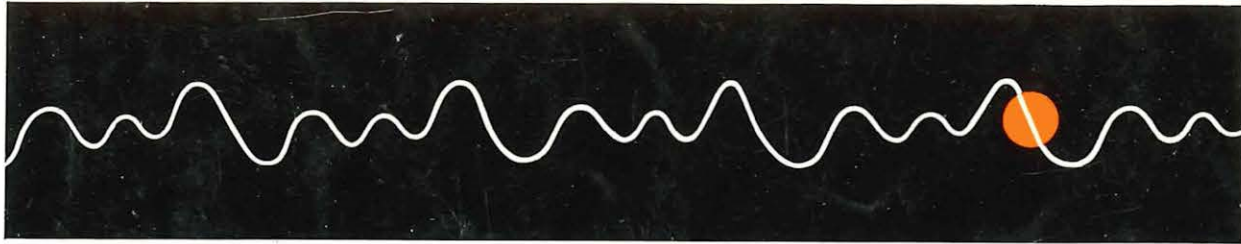
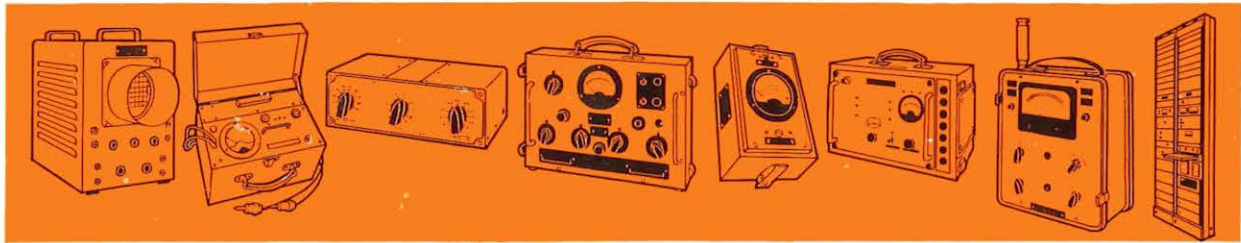

STC TESTING AND MEASURING APPARATUS In all branches of telecommunication and electronics, control to the highest degree is imperative... control through testing... check and double-check. STC covers every aspect of these vital operations... helps you get the measure of things... puts you in complete control. Oscillators, Signal generators, Sending units, Level measuring sets, Selective level measuring sets, Transmission measuring sets, S.H.F. power measuring sets, Milliwatt test sets, Repeater testing equipment, Octave filters, Attenuators, Networks, Microwave wavemeters and reflection factor measuring equipment, Sound level meters, Psophometers, Noise generators, White noise testing equipment, Signalling test sets, Cable test sets, Cable search equipment, Resistivity meters, Television test trolleys. Write, 'phone or Telex for detailed information to Standard Telephones and Cables Limited, Testing Apparatus Division, Corporation Road, Newport, Mon. Telephone Newport 72281 (STD ONE 3). Telex 49367. London Office 'phone ALBert Dock 1401 (Ext. 758).

world-wide telecommunications and electronics **STC**