

THE POST OFFICE ELECTRICAL ENGINEERS' JOURNAL



CONTENTS

	Page
SMALL-DIAMETER COAXIAL-CABLE DEVELOPMENTS—A. F. G. Allan, A.M.I.E.E.....	1
IMPROVEMENTS IN THE 15 CWT CLASS OF ENGINEERING VEHICLE—A. I. Campbell	9
INAUGURATION OF THE COMMONWEALTH PACIFIC CABLE (COMPAC).....	14
CALCULATION OF CURRENT VALUES FOR DETERMINING BUS-BAR SIZES IN AUTOMATIC TELEPHONE EXCHANGES—R. C. Kyme, A.M.I.E.E., and W. Scanlan	15
CONNEXIONS TO PRINTED-CIRCUIT BOARDS—K. W. Hix, A.M.I.E.E.....	22
THE POST OFFICE TYPE 12 RELAY—B. H. E. Rogers and A. Knaggs	27
AN AUTOMATIC SCREW-SORTING MACHINE—G. Haley, B.Sc.(Eng.), A.M.I.E.E., and T. F. A. Urben, B.Sc.(Eng.), A.M.I.E.E.....	32
A TRANSISTOR-TYPE SELF-SYNCHRONIZING 7-UNIT MONITOR FOR AUTOMATIC ERROR-CORRECTING RADIO-TELEGRAPH SYSTEMS—D. A. Chesterman	37
AIR-CONDITIONING IN COMPUTER ACCOMMODATION—M. Stephenson, A.M.I.E.E., and R. G. Fiddes, B.Sc.(Eng.), A.M.I.E.E.	39
TWENTY-ONE YEARS OF SUBMARINE REPEATERS—R. A. Brockbank, O.B.E., Ph.D., B.Sc., M.I.E.E.....	46
A NEW WAY TELEPHONE—TELEPHONE No. 711—F. J. Harvey, A.M.Brit.I.R.E.....	51
THE ELECTRICAL PROPERTIES OF HIGH-FREQUENCY TRANSISTORS—H. G. Bassett, B.Sc.(Eng.), A.M.I.E.E., and P. E. Greenaway, B.Sc.	54
NOTES AND COMMENTS.....	60
INSTITUTION OF POST OFFICE ELECTRICAL ENGINEERS	60
REGIONAL NOTES.....	62
ASSOCIATE SECTION NOTES.....	65
STAFF CHANGES.....	68
PAPERS AND ARTICLES ON TELECOMMUNICATIONS AND OTHER SCIENTIFIC SUBJECTS	71
BOOK REVIEWS	13, 26, 31, 36, 59, 61

Price 3s. (Post Paid 4s.)

Published in April, July, October and January by *The Post Office Electrical Engineers' Journal*,
G.P.O., 2-12 Gresham Street, London, E.C.2.

Annual Subscription (post paid): Home, 16s.; Overseas, 17s. (Canada and U.S.A., 2 dollars 75 cents).

THE POST OFFICE ELECTRICAL ENGINEERS' JOURNAL

Vol. 57 Part 1

APRIL 1964

Small-Diameter Coaxial-Cable Developments

A. F. G. ALLAN, A.M.I.E.E.†

U.D.C. 621.315.312

The advantages that can be gained by the use of transistor amplifiers accommodated in manholes or jointing chambers have led to a rapid development of coaxial pairs of much smaller size than the 0.375 in. diameter tubes of the past. A description is given of the determination of the performance-specification requirements for a new standard small-diameter coaxial cable and of the various constructional methods that have been evolved.

INTRODUCTION

NEARLY 5,000 sheath-miles of coaxial cable are now in service in the United Kingdom, the majority of this mileage incorporating coaxial pairs of 0.375 in. diameter.¹ Recently, however, a number of routes have been installed in which cables containing coaxial pairs of a much smaller diameter (0.174 in. diameter) have been employed. The two types of coaxial cable are compared in Fig. 1.

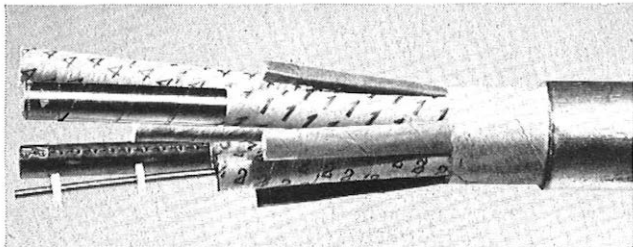

(a) Typical 375-type Coaxial Cable

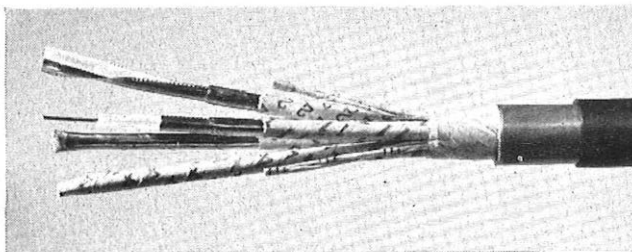

(b) Typical 174-type Coaxial Cable

FIG. 1—COMPARISON OF 375-TYPE AND 174-TYPE COAXIAL CABLES

Earlier articles^{2,3} have discussed the reasons for the present trend towards small-diameter coaxial cables

†Main Lines Development and Maintenance Branch, E.-in-C.'s Office.

equipped with transistor amplifiers accommodated in underground jointing chambers, and have given some indication of the form of cable provided for the early schemes. Experience with these first experimental cables, confirming some suspected limitations and demonstrating others, rendered redesign essential, and in producing a performance specification for a new standard cable it also became necessary to take into consideration international agreements on the characteristics and utilization of small-diameter coaxial cables.

The British cable industry has, so far, developed four separate designs of coaxial pair, all of which comply with the British Post Office specification, and a description is given of each type.

EXPERIMENTAL SYSTEMS AND COAXIAL-PAIR DESIGN

Cable attenuation, amplifier maximum gains, and amplifier spacings are all interdependent and are governed by the maximum circuit capacity of the system that it is intended to operate. The first small-diameter coaxial-cable schemes were designed by two separate cable and equipment manufacturing organizations,^{2,4} and both designs were based on the requirement, generally accepted at that time, for systems to provide somewhat similar facilities to the 24-circuit carrier network but with an increased capacity, per pair of tubes, of 60, 120, or possibly 300, circuits, i.e. one to five supergroups.

It was envisaged that cables with a number of pairs of tubes would be provided along a main route, individual pairs of tubes being intercepted at intervals to provide shorter-distance traffic routes of one, two, or more supergroups capacity, without the necessity for providing supergroup derivation equipments.⁵ As a result of these considerations it was determined that a cable with an attenuation of some 10.6 db/mile at 1 Mc/s, with amplifiers of 27 db maximum gain and spaced at 4,000 yd intervals, would provide the most economic arrangement.

Coaxial-Pair Design

The attenuation of a coaxial pair is dependent, primarily, upon the dimensions of the conductors, and minimum attenuation is achieved when the ratio of the internal diameter of the outer conductor to the external diameter of the inner conductor is 3.6:1.0. Deviations from this ratio as far as 3.0:1.0 in one direction

and 4.4 : 1.0 in the other, however, increase the attenuation by little more than 1 per cent.

The characteristic impedance of a coaxial pair, with the optimum conductor-diameter ratio of 3.6 : 1.0 and, for practical purposes, 100 per cent air dielectric, is 75 ohms over a wide range of frequencies. If the dielectric is not air, the impedance will vary according to the material used and, of course, the frequency at which it is measured. With dielectrics such as solid polythene, which is commonly employed in high-frequency (h.f.) flexible cables, the impedance is of the order of 50 ohms at 1 Mc/s.

In the first type of small-diameter coaxial cable produced (Cable, Coaxial, 163A) the overall diameters of the conductors were considerably smaller than for 0.375 in. (375-type) cables, and the ratio of outer to inner conductor diameters was exactly 3.6 : 1.0 (0.163 in. : 0.0453 in.), resulting in an attenuation within the 10.6 ± 0.3 db/mile specified at 1 Mc/s. The insulating medium between inner and outer conductors, however, was neither air nor solid material but a foam of expanded polythene, an enlarged cross-section of which is shown in Fig. 2. This coaxial pair, therefore, had a designed

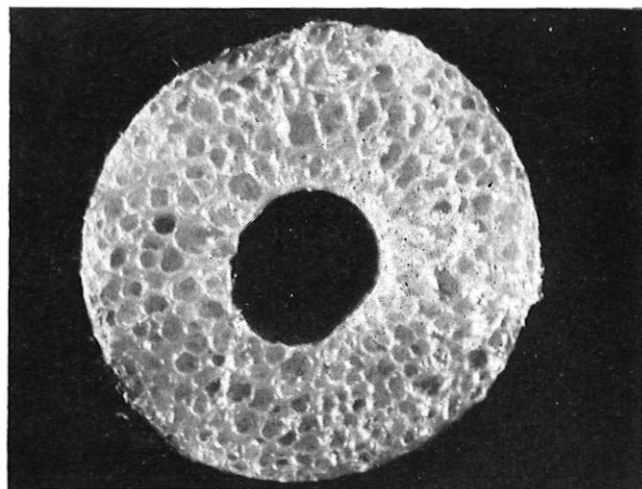

FIG. 2—ENLARGED CROSS-SECTION OF EXPANDED POLYTHENE FOAM INSULANT

characteristic impedance of 66 ohms at 1 Mc/s, and whilst it is possible to design all associated equipment to have a 66-ohm impedance, it is advantageous for such equipment to have the 75-ohm impedance common to all other standard coaxial systems and test gear in use in the network.

The second type of cable produced (Cable, Coaxial, 163B) retained the 0.163 in. internal diameter of the outer conductor and the foamed-polythene insulant, but the diameter of the inner conductor was reduced to 0.0379 in. Although this change meant a conductor diameter ratio of 4.3 : 1.0, the attenuation change was not sufficient to exceed the specified limits, but the characteristic impedance at 1 Mc/s became 75 ohms. Fig. 3 illustrates the construction of the 163A-type and 163B-type pairs, and, with the exception of the foamed-polythene insulant in place of polythene disks, the method of construction follows that employed for large-diameter coaxial pairs.

Overall Cable Design

Whilst a reduction in overall costs would have been

achieved by the utilization of a small-diameter coaxial cable of traditional paper-insulated lead-sheathed form,

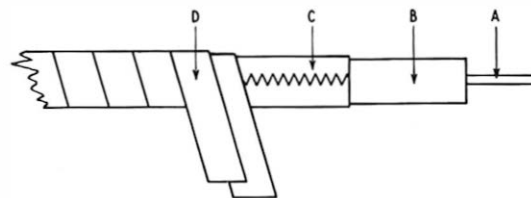

A—Inner conductor 0.0453 in. diameter (163A-type) or 0.0379 in. diameter (163B-type)

B—Expanded polythene-foam insulant

C—Outer conductors: longitudinal copper tape rolled to form tube 0.163 in. inner diameter and 0.007 in. thick

D—Two steel tapes, 0.004 in. thick, overlapped

FIG. 3—CONSTRUCTION OF 163A-TYPE AND 163B-TYPE COAXIAL PAIRS

the rising interest in plastics as materials for cable construction suggested that even greater cost reductions might be achieved by dispensing with a lead sheath and separate anti-corrosion protection and by using only a simple polythene sheath. Both the 163A-type and 163B-type cables employed this method of construction, and, in addition, coloured plastic tapes were used to lap the coaxial pairs instead of the usual numbered paper tapes; all interstice pairs were also polythene insulated.

The problems that such a completely new constructional method might present had been carefully considered, but proof that such problems would actually exist, or that other unknown difficulties might not also arise could only be gained by installing cables of this type.

Difficulties in fault location, similar to those experienced on all-polythene audio cables, were only too real. Furthermore, joint failures, water permeation and penetration, and lack of screening against external h.f. transmissions threw some doubt on the efficiency of all-polythene construction for this type of cable. Nevertheless, it must be recorded that a number of short-distance television links have been provided on both 163A-type and 163B-type cables in London and elsewhere, and, so far, there is no evidence of unreliability.

C.C.I.T.T. RECOMMENDATIONS

Whilst in the United Kingdom effort had been directed towards the development of small-diameter coaxial pairs with an attenuation of just over 10 db/mile at 1 Mc/s for use with line systems of up to 300 circuits capacity, in other countries a somewhat different approach had been made. In France, for instance, a cable had been designed* and laid that contained coaxial pairs with an attenuation of only 8.5 db/mile at 1 Mc/s and which were equipped with amplifiers of 35 db maximum gain. For 300-circuit working the amplifier spacing was to be 5.8 km, but a longer view had been taken that, ultimately, amplifiers would be spaced at 3 km intervals for systems transmitting up to 4 Mc/s (960 circuits). With such 4 Mc/s systems as the possible extension of utilization, the smaller British 163A-type and 163B-type cables would no longer be an economic design.

After consideration by the C.C.I.T.T.,* the higher-capacity standard was recommended for general adoption, and it was decided that new work in the United Kingdom should comply. This decision was of great

*C.C.I.T.T.—International Telegraph and Telephone Consultative Committee.

importance to the cable manufacturers for, though faced with the problem of completely redesigning the small-diameter coaxial pair, a speedy solution was essential.

Early in 1961 the Post Office requested the British cable industry to consider the design and production of a small-diameter cable to meet the new recommendations. A performance specification covering all the electrical requirements (the C.C.I.T.T. had not, at that time, dealt with all the points that need to be specified in a comprehensive document) was prepared by the Post Office and it is gratifying to record that subsequent C.C.I.T.T. deliberations have not made necessary any significant amendments to the original British specification.

For this redesigned small-diameter coaxial cable the use of polythene is confined to the coaxial-pair dielectric and the anti-corrosion protection; the remainder of the cable is of conventional paper-insulation and lead sheath form.

DETERMINATION OF SPECIFICATION LIMITS FOR A SMALL-DIAMETER COAXIAL PAIR

Attenuation

The new recommendation for attenuation at 1 Mc/s was to be 8.5 db/mile, but some deviation must be allowed in practice. To arrive at a figure for the maximum possible variations in the attenuation/frequency characteristic some thought has to be given to the method of operation; cables can no longer be designed independently of the line systems with which they will be associated.

Equipment design determined that the variation of attenuation at 1 Mc/s should not exceed 1 db in an amplifier section, or 0.4 db/mile. The specification limits were set, accordingly, at 8.5 ± 0.2 db/mile at that frequency.

Having fixed the 1 Mc/s point, and having specified the thickness and diameters of the conductors, there is very little that can be done to affect the attenuation at other frequencies. Nevertheless, some check has to be made to ensure that no unforeseen factors influence the attenuation/frequency characteristic—pre-emphasis networks and line equalizers have to be designed to match a known characteristic—and the attenuation at frequencies above and below 1 Mc/s has, therefore, to be specified. The requirements for the new type of cable are shown in Table 1.

TABLE 1
Attenuation of Cable at Specific Frequencies

Frequency (Mc/s)	0.06	0.10	1.0	1.4	1.5-4.5	4.5-7.5
Attenuation (db/mile)	2.4 ± 0.1	2.9 ± 0.1	8.5 ± 0.2	10.0 ± 0.2	To be within 2 per cent of the attenuation calculated from $A = x\sqrt{f}$ (Note)	To be within 3 per cent of the attenuation calculated from $A = x\sqrt{f}$ (Note)

Note: A = attenuation (db/mile), x = attenuation (db/mile) at 1 Mc/s, and
= frequency in Mc/s.

It will be seen that the specification covers a range from 0.06-7.5 Mc/s, although the original requirement was for a range only up to 1.5 Mc/s. In the future, however, the pairs will undoubtedly be required to carry

4 Mc/s telephony systems and television transmissions. It was thought that the new cable should be made capable of utilization for all possible requirements foreseen at an early stage in development.

An interesting design aspect, in connexion with attenuation, arose as the result of specifying an outer-conductor thickness of 0.007 in. with a manufacturing tolerance of ± 0.0003 in. Another administration demonstrated that at frequencies below 200 kc/s differences of attenuation between similar lengths of coaxial pair might be reduced by utilizing an outer conductor with a thickness of 0.008 in. Whilst this is true, it is equally true that an even better result would be achieved by using outer conductors of 0.009 in. or even 0.010 in. thickness (Fig. 4), as is used for the larger 0.375 in. pair, but it

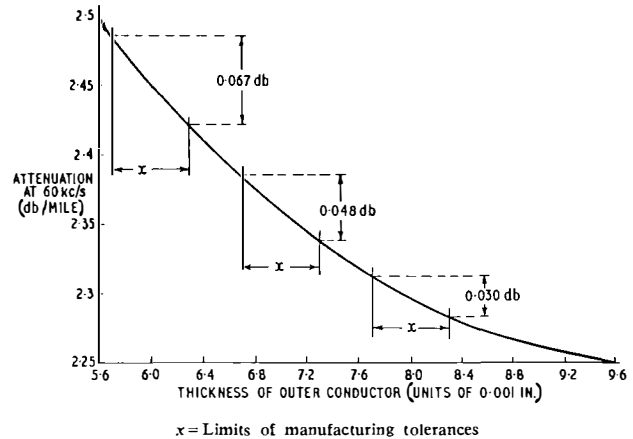

FIG. 4—RELATION OF ATTENUATION TO THICKNESS OF OUTER CONDUCTOR

has to be remembered that each additional 0.001 in. of copper adds about 15 per cent to the cost of the outer conductor. The advantage to be gained did not appear to justify the extra cost, and the specified outer-conductor thickness remains at 0.007 in.

Impedance

As with attenuation, once a value is specified for impedance at one particular frequency, and the design has been such that this value has been achieved, there is little that can affect the values obtained at other frequencies. It is, however, very important to the main-

tenance staff that deviation from the nominal values shall not be great. When replacing faulty lengths of cable little difference can be allowed between the impedance of the replacement length and that of the cable into

which it is being connected. Abrupt impedance changes produce signal reflections at the jointing point, and the magnitudes of these reflections must be controlled if transmission, particularly of television signals, is to remain unaffected.

To achieve absolute certainty that there would be no reflections worse than those specified, the impedance of each cable length would need to be controlled to within 0.15 ohm of the nominal, but this would assume that at every replacement a cable of, say, 75.15 ohms impedance was being joined to one with an impedance of 74.85 ohms. In practice, the chances of this happening—a cable length of maximum impedance being joined to one of minimum impedance—are relatively remote, so that it is permissible to relax the limits to some extent, and for the new cable the impedance limits at 1 Mc/s were set at 75 ± 0.5 ohms, a standard which is by no means simple to achieve in manufacture, an 0.001 in. change in diameter of the inner conductor altering the impedance by more than 1.0 ohm.

To ensure regularity of impedance throughout a coaxial pair and thus avoid major signal reflections, the C.C.I.T.T. recommended, some years ago, standards for pulse reflections for coaxial pairs intended to carry television transmissions. These requirements were incorporated in all Post Office specifications for 375-type cables, irrespective of whether the pairs were to be used for telephony or television links, for the utilization can be changed at any time. It was not expected that the 163A-type and 163B-type could achieve such high standards, and the specifications limits for these cables were considerably relaxed.

As far as the new small-diameter coaxial pair was concerned it was decided that every effort should be made from the outset to produce a cable capable of meeting the original C.C.I.T.T. pulse-reflection standards, and the specification therefore requires that no impedance irregularity shall give rise to a reflected signal the level of which exceeds the limit of 54 db below the level of the transmitted signal at the point of application of the signal. Due allowance is made for attenuation of the testing pulse to and from the reflection point.

Far-End Crosstalk

The C.C.I.T.T. agreed a length of 280 km (175 miles) for the reference system, and recommended that the far-end system-to-system signal-to-crosstalk ratio should not be less than 58 db, half of which should be allowed to the line equipment and terminal equipment and half to the cable itself. Thus, for a theoretical unamplified cable 175 miles long, the far-end signal-to-crosstalk ratio should be 61 db or better.

As the far-end crosstalk contribution from each amplifier section, being always in phase with the transmitted signal, is directly additive (on a voltage basis) it is possible to calculate the allowable limits for an amplifier section of any length or, indeed, for any individual length of cable. The formula applied, in its complete form, is as follows: far-end signal-to-crosstalk ratio should not be less than

$$61 + 20 K \log_{10} \frac{175}{x} - m \text{ db,}$$

where x is the length (in miles) of the cable section being measured, and K and m are constants.

K is a factor which depends upon the method of con-

nexion of the amplifiers. If all amplifiers are connected normally $K = 1$, but if phase inversion is employed (see Fig. 5) the value of K will be less than unity and, in a

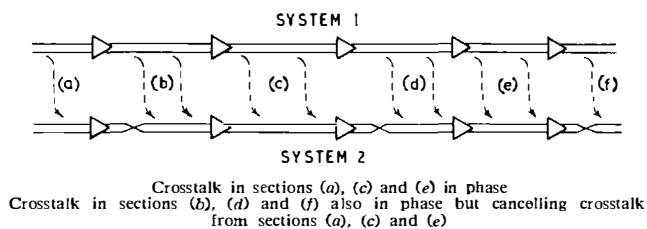

FIG. 5—PHASE-INVERSION CONNEXIONS

theoretically perfect example where a system employing phase inversion consisted of an even number of amplifier sections each of equal length and each contributing a precisely similar amount of crosstalk, K would be negative. There is no intention of using phase-inversion in British systems, unless it is made necessary by special circumstances, and, therefore, K has been taken as equal to unity.

The constant m is to allow for the fact that it is probably unnecessary to insist that the far-end crosstalk in each amplifier section shall not exceed the limit called for, i.e. $61 + 20 \log_{10} \frac{175}{x}$ db. If some sections are slightly worse, others will be, in all probability, far better. To cover this random variation, the Post Office specification has allowed 5 db for m .

The final specification states that the system-to-system far-end signal-to-crosstalk ratio in amplifier sections shall not be less than $56 + 20 \log_{10} \frac{175}{x}$ db throughout the range 60 kc/s – 7.5 Mc/s, where x is the length of the amplifier section in miles.

Examining a single amplifier section, Fig. 6 and Table

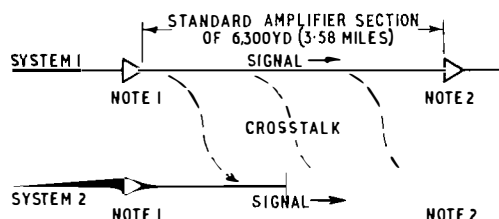

Notes:

1. Signal output levels: at 0.06 Mc/s, -20.0 db; at 1 Mc/s, -17 db; at 1.4 Mc/s, -12.5 db.
2. Signal input levels: at 0.06 Mc/s, -29 db; at 1 Mc/s, -47 db; at 1.4 Mc/s, -48.5 db.

FIG. 6—FAR-END CROSSTALK IN STANDARD AMPLIFIER SECTION

2 indicate the various signal and crosstalk levels that may be expected. The signal-to-crosstalk ratio of 89.6 db is the minimum allowable and, in practice, the ratio usually exceeds 94 db even at the lowest frequency of 60 kc/s. At higher frequencies, of course, crosstalk attenuation increases rapidly, a normal property of coaxial structures.

For music circuits (in the carrier band) the overall 175-mile system signal-to-crosstalk ratio limit of 61 db is not considered satisfactory, and a figure of 77 db (i.e. some 16 db better) has been specified as the minimum acceptable. However, it is improbable that any British inland system will approach the C.C.I.T.T. reference length of 175 miles and, in fact, from the practical signal-to-crosstalk ratio figures already measured (as shown

in Table 2), provided music channels are located above 300 kc/s (i.e. supergroup 2 or above), the 77 db signal-to-crosstalk ratio should be achieved.

TABLE 2

Theoretical and Practical Signal and Far-End Crosstalk Ratios in Standard Amplifier Section

Frequency (Mc/s)	Amplifier-Section Loss (db)	Required Far-End Signal-to-Crosstalk Ratio (db) as Determined by Formula*	Typical Measured Far-End Signal-to-Crosstalk Ratio (db)
0.06	8.6	89.6	95.0
1.0	30.4	89.6	140.0
1.4	36.0	89.6	>140.0

* $56 + 20 \log_{10} 175/x$ db, where x is length of section in miles.

Near-End Crosstalk

The determination of near-end crosstalk limits follows somewhat similar considerations, but as the contributions from the various crosstalk paths may or may not be in phase, near-end crosstalk does not become directly additive (on a voltage basis) from one amplifier section to the next.

It is not possible to deduce how the contributions from each amplifier section will add, and a compromise between complete addition from one section to the next (voltage or "in-phase" addition) and complete cancellation from one section to the next (completely "out-of-phase" addition) has been adopted. The compromise is the assumption that near-end crosstalk is additive from section to section on a power basis.

To achieve results similar to those for far-end crosstalk, near-end crosstalk at the amplifier inputs at the end of the system must not exceed a level of 61 db below the level of the signal at that point. The limit for each amplifier section is calculated from the expression: near-end signal-to-crosstalk ratio should not be less than

$$61 + 10 \log_{10} \frac{175}{x} \text{ db,}$$

where x is the length of the section in miles. An arbitrary 3 db is added to the expression above to account for random "rolls" in the near-end crosstalk/frequency characteristic.

In practice, near-end crosstalk attenuation is more simply measured than the signal-to-crosstalk ratio, and

therefore it is necessary to ascertain a formula which is applicable to this method of testing. For a standard 6,300 yd amplifier section the considerations that apply are shown in Fig. 7 and Table 3.

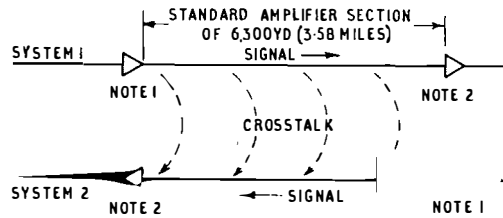

- Notes:
1. Signal output levels: at 0.06 Mc/s, -20 dbr; at 1 Mc/s, -17 dbr; at 1.4 Mc/s, -12.5 dbr.
 2. Signal input levels: at 0.06 Mc/s, -29 dbr; at 1 Mc/s, -47 dbr; at 1.4 Mc/s, -48.5 dbr.

FIG. 7—NEAR-END CROSSTALK IN STANDARD AMPLIFIER SECTION

The formula specified for near-end crosstalk attenuation—that it should be not less than $89 + 24 \sqrt{f}$ db over the range 0.06–7.5 Mc/s, where f is the frequency of test in Mc/s—was originally derived from a study of the results obtained with both the 375-type coaxial cables and with the earlier 163-type small-diameter coaxial cables. It was felt that figures somewhat better than those obtained with 163-type cable should be achieved, but that it would be possible to obtain results similar to those obtained with 375-type cables was thought to be a little ambitious.

The simple formula $89 + 24 \sqrt{f}$ meets the requirements of the C.C.I.T.T. recommendations except that it does not relate crosstalk attenuation to the length of the section under test, but field-test results have been so good that any slight discrepancy has little significance.

A. C. Ionization

A.C. ionization is a completely new requirement to be included in a Post Office inland-cable specification. It has been known for some considerable time that intermittent discharges in coaxial cables and associated equipment carrying relatively high a.c. voltages cause interference with television-signal transmissions.

Test apparatus is available that makes it possible to test components or cable pairs in order to determine the maximum a.c. voltage that can be applied without causing discharges, and the test equipment is sufficiently sensitive to detect discharges of magnitudes well below those at which interference will be caused. Whilst it is

TABLE 3
Theoretical and Practical Signal and Near-End Crosstalk Ratios and Attenuation in Standard Amplifier Section

Frequency (Mc/s)	Amplifier-Section Loss (db)	Required Near-End Signal-to-Crosstalk Ratio (db) as Determined by Formula*	Minimum Crosstalk Attenuation (db) Determined by Formula* and Section Loss	Minimum Crosstalk Attenuation (db) from Post Office Formula†	Typical Measured Crosstalk Attenuation (db)
0.06	8.6	80.9	89.5	95.0	115.0
1.0	30.4	80.9	111.3	113.0	160.0
1.4	36.0	80.9	116.9	117.0	160.0

* $61 + 10 \log_{10} 175/x + 3$ db, where x is length of section in miles.

† $89 + 24 \sqrt{f}$, where f is frequency in Mc/s.

desirable that interference-free television transmissions shall be ensured, the check that no ionization discharges will occur at the a.c. voltages applied is of even more fundamental importance, for discharges of any kind may ultimately lead to complete breakdown.

To apply this test to the new small-diameter coaxial pair might appear to be superfluous for, at present, it is not envisaged that in normal use high a.c. voltages will be connected to these pairs. The high-voltage a.c. test, however, can reveal manufacturing imperfections that might remain undetected by any other means, even including high-voltage d.c. checks.

Owing to the reduced distance between the conductors in the new type of coaxial pair, the specification calls for overall insulation between inner and outer conductors throughout the length of the pair and also through any joints. This overall insulation can mask various imperfections, e.g. whiskers or slivers of copper protruding from the conductors, and may itself include air voids which may break down under electrical stress. Furthermore, damage may occur, e.g. crushing or distortion of the coaxial pairs over very short distances, which it is impossible to detect by other tests.

The specification calls for complete absence of a.c. ionization up to 500 volts a.c., and this test is applied to all coaxial pairs in all lengths manufactured and also in all jointed amplifier-sections.

Other Requirements

In addition to the requirements already described, conductor-resistance, insulation-resistance and d.c. high-voltage tests are specified.

PHYSICAL DESIGNS FOR THE NEW SMALL-DIAMETER COAXIAL PAIR

Within 6 months of the original request to the cable manufacturers, sample lengths of 4-pair cable were submitted for type testing. The internal diameter of the outer conductors of the coaxial pairs had been fixed at 0.174 in. in all instances, but the external diameters of the inner conductors varied slightly to allow for the differing forms of the dielectric. As mentioned earlier, this is necessary to adjust the impedance value to meet the specification requirement of 75 ohms at 1 Mc/s. In general the inner-conductor diameter is approximately 0.0456 in., giving an outer-to-inner diameter ratio of 3.74 : 1.0.

Four manufacturers followed somewhat different methods of construction, as indicated in Fig. 8, and a description of the final form of each follows.

The "Worm"-Type Pair

The inner conductor is supported in position at the centre of the outer conductor by a "worming" of small-bore polythene tubing. This spiral-worm principle is not unknown in coaxial-pair structures, having been utilized in some of the early large-diameter pairs. Overall insulation between inner and outer conductors is provided by a lapping of high-density polythene tape outside the worming.

A novel form of construction for the outer conductor is introduced in that the edges of the tube formed from rolling a flat copper tape do not merely butt together along the length of the tube but are argon-arc welded to form a solid tube. Two steel tapes are helically

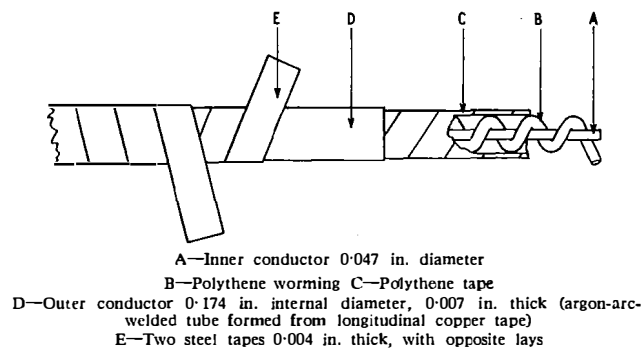

(a) Worm-Type Coaxial Pair

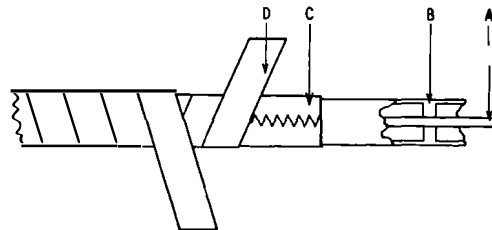

(b) Bamboo-Type Coaxial Pair

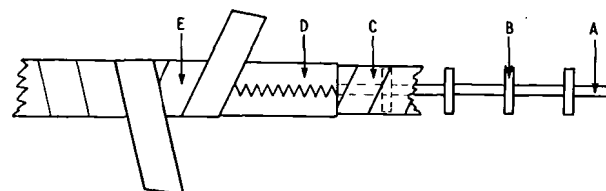

(c) Disk-Type Coaxial Pair

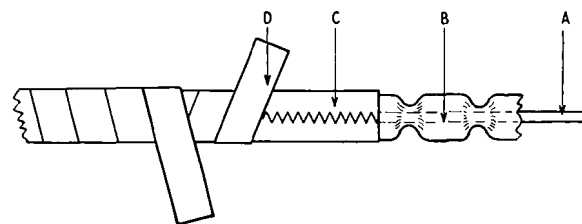

(d) Balloon-Type Pair

FIG. 8—CONSTRUCTION OF 174A-TYPES OF COAXIAL PAIR

wrapped around the outer conductor to provide electromagnetic screening, one tape having an opposite "lay" to the other. The angle at which the two steel tapes cross each other is important, and tape widths and thicknesses are chosen to enable a 90° crossover to be achieved.

The effects of different crossover angles on crosstalk attenuation at low frequencies are illustrated in Fig. 9. A numbered paper tape completes each coaxial unit.

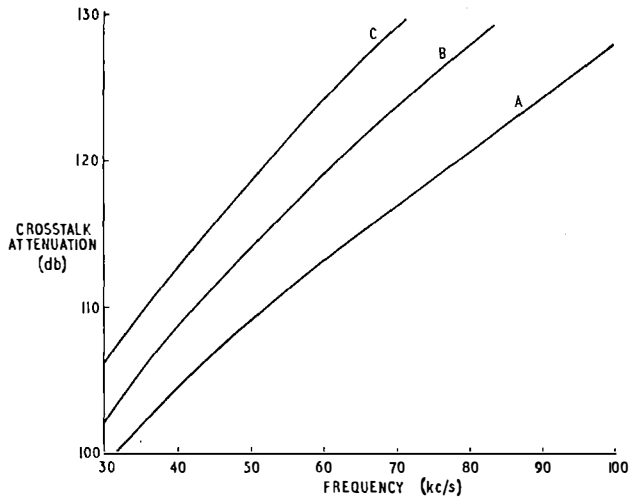
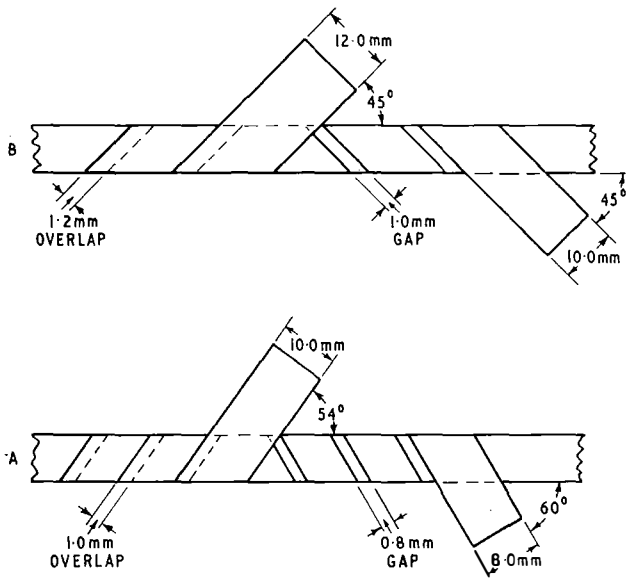

FIG. 9--COMPARISON OF EFFECTS OF DIFFERENT METHODS OF APPLYING OUTER STEEL TAPES



(b) Types of Steel-Tape Lapping Referred to in (a)

FIG. 9--COMPARISON OF EFFECTS OF DIFFERENT METHODS OF APPLYING OUTER STEEL TAPES

The "Bamboo"-Type Pair

So far as the outer conductor is concerned, the bamboo-type coaxial pair does not differ in construction from the standard 375-type or the 163-type; the copper tape is rolled longitudinally to form a tube, with the edges of the tape butted together. The provision of overall insulation and support of the inner conductor in its central position within the tube is, however, achieved in a very ingenious manner; the processes involved are shown in Fig. 10. Two crossed steel tapes and a numbered paper tape complete the coaxial unit.

The "Disk"-Type Pair

For the third version, standard 375-type pair practice was followed with individual polythene disks maintain-

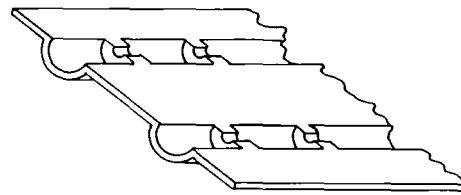

(a) Stage 1: Polythene Extrusion—Two Half-Tubes Complete with Half-Disks

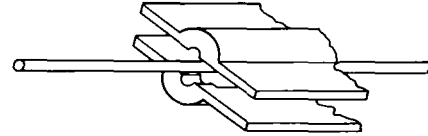

(b) Stage 2: Extrusion Divided on Centre Line and Two Halves Placed on Inner Conductor

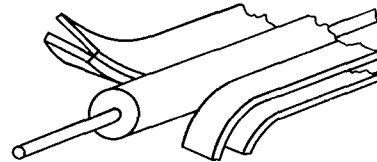

(c) Stage 3: Two Halves of Tube Welded Together and Excess Wings Cut Away



(d) Stage 4: Construction Completed; Inner Conductor contained in Centre of Inner Tube

FIG. 10--METHOD OF CONSTRUCTION OF BAMBOO-TYPE COAXIAL PAIR

ing the inner conductor at the centre of the outer-conductor tube. To provide overall insulation, a high-density polythene tape is lapped over the disks. Two crossed steel tapes and a numbered paper tape complete the unit.

The "Balloon"-Type Pair

The balloon-type version is a replica of the French design, in which the inner conductor is maintained within the outer conductor, and overall insulation provided by a simple polythene tube pinched at intervals to grip the inner conductor. Crossed steel tapes and a numbered paper tape are lapped over the outer conductor.

Construction of Complete Cable

Where small-tube coaxial pairs are to be included in a composite cable, i.e. one having audio layer pairs in addition to the coaxial and interstice pairs, suitable precautions have to be taken to ensure that the insulation between the coaxial core of the cable and the layer pairs is sufficient to withstand any high differences of potential. It must be remembered that the outer conductors of the coaxial pairs will not be earthed other than at the extreme ends of the h.f. system, whereas layer pairs may be intercepted at numerous points along the length of the cable and may be connected to many different points. Breakdown between layer pairs and the tubes might cause damage to the transistors in the amplifiers on the h.f. route. Sufficient paper lappings are therefore wrapped around the coaxial core to ensure that no breakdown occurs when a potential of 1,000 volts d.c. is applied between the coaxial and interstice conductors (all

connected together) and the layer pairs (all connected together).

A lead sheath and polythene protection has been specified, as mentioned earlier.

TEST PROCEDURES

Special care has been taken in the methods adopted to prove the characteristics of the new cables—all versions being coded for the present as Cables, Coaxial, 174A—as the field of possible use in the future appears to be quite wide. At first a 200 yd length of each type was subjected to a comprehensive 3-day program of type tests. Once the sample proved satisfactory, both electrically and physically (and all versions did not pass the tests on the first occasion), the manufacturer was given a contract for a short route (1–2 miles) in normal duct conditions in London. These short routes are used, as required, for television outside-broadcast transmission, but there are periods when the pairs are not in service and opportunity is taken of these idle periods to make various tests.

The London routes have enabled an assessment to be made of the qualities of each type of cable for full traffic use in conditions likely to be met with in any part of the national network. They have also permitted the jointing and termination methods to be evaluated. It is of interest that coaxial-conductor jointing is now being carried

TABLE 4
Factory Measurements of Impedance at 1 Mc/s

Production Run	Number of Samples	Impedance (ohms) at 1 Mc/s		
		Mean	Standard Deviation	Range
A	41	75.19	0.23	74.8–75.7
B	418	75.0	0.15	74.6–75.4
C	72	74.94	0.3	74.5–75.7
D	77	74.98	0.2	74.4–75.5

TABLE 5
Factory Measurements of Reflected Signals

Production Run	Number of Samples	Worst (Corrected) Echo (dbr)		
		Mean	Standard Deviation	Range
A	36	59.1	3.3	51.0–67.0
B	418	58.0	3.4	49.0–68.0
C	45	57.8	1.95	54.0–66.0
D	77	60.3	2.4	55.0–68.0

out using brazing techniques, and no soldered joints are made except at terminations.

QUALITY OF PRODUCTION

Many lengths of the new cable have already been manufactured for the first of the longer-distance routes to be planned, and in some instances the cable is already installed and jointed. An examination of factory test results indicates that the British cable industry is producing a cable of very high quality; Tables 4, 5 and 6

TABLE 6
Factory Measurements of Capacitance

Production Run	Number of Samples	Capacitance (μ F/mile)		
		Mean	Standard Deviation	Range
A	20	0.079	0.00047	0.0785–0.0810
B	209	0.0784	0.0002	0.0779–0.0795
C	35	0.0802	0.00053	0.0794–0.0816
D	77	0.0787	0.00025	0.0781–0.0794

give figures for three of the more important characteristics measured at the factory on four production runs.

CONCLUSION

There is now little doubt that more and more use will be made of small-diameter coaxial cables in the future. The installation of some 60–70 inland trunk routes is already planned for the next few years, some of these routes being equipped for 300-circuit working and others for the wider 4 Mc/s band (960 circuits). A large number of 174-type coaxial pairs will also be provided in the Post Office radio towers in London and Birmingham for equipment-interconnexion purposes, transmitting frequencies up to 70 Mc/s, and experiments will be commencing soon in the high-frequency pulse-code-modulation techniques at frequencies of the order of 150–300 Mc/s.

ACKNOWLEDGEMENTS

The author wishes to acknowledge the assistance given in the preparation of this article by the following organizations: Pirelli-General Cable Co., Ltd., Standard Telephones & Cables, Ltd., Telephone Cables, Ltd., and British Insulated Callender's Cables, Ltd.

References

- ¹ROSSITER, G. E. Coaxial Cables—Some Practical Aspects of their Design and Maintenance. I.P.O.E.E. Printed Paper No. 205, 1953.
- ²ENDERSBY, J. C., and SIXSMITH, J. Coaxial Line Equipment for Small-Diameter Cables. *P.O.E.E.J.*, Vol. 55, p. 44, Apr. 1962.
- ³CLINCH, C. E. E., and STENSON, D. W. Housing of Repeater Equipment Underground. *P.O.E.E.J.*, Vol. 56, p. 158, Oct. 1963.
- ⁴HELLIWELL, B. S., and WILKINSON, F. Small-Diameter Coaxial System. *A.T.E. Journal*, Vol. 16, p. 13, Jan.-July 1960.
- ⁵BLANCHARD, C. H., and CRISP, A. J. Supergroup Derivation Equipment. *P.O.E.E.J.*, Vol. 54, p. 196, Oct. 1961.
- ⁶BELUS, R. La Paire Coaxiale de 1.18/4.43 mm. Normalisée pour Câble à Grand Distance. *Câbles & Transmission*, 14 A, N°4, Oct. 1960.

Improvements in the 15 cwt Class of Engineering Vehicle

A. I. CAMPBELL†

U.D.C. 629.114.4

Many manufacturers of commercial vehicles market a range of mass-produced variants of a basic light van so as to give the customer the option of having additional facilities or features at reasonable cost. The British Motor Corporation J2 range of vehicles is in this category and has been exploited to provide 15 cwt Post Office engineering vehicles of improved suitability and, in some instances, reduced cost.

INTRODUCTION

AMONG the 370 engineering vehicles of 10 cwt to 1-ton capacity in service in 1932, a substantial proportion were of 15 cwt capacity. These 15 cwt vehicles were equipped with a range of three types of coach-built body, one, illustrated in Fig. 1, being expressly designed for subscribers' apparatus installation duties, another for cable-jointing and the third for stores-carrying. Such early designs, with their restricted fields of use, did not meet the increasing demand for more

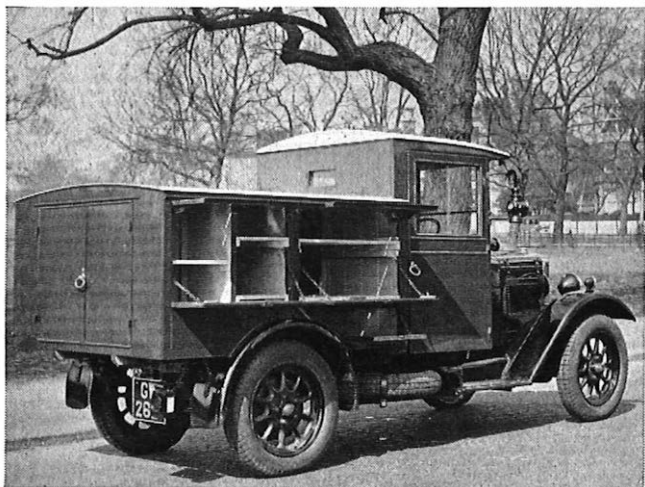

FIG. 1—1932 15 CWT VEHICLE DESIGNED FOR SUBSCRIBERS' APPARATUS INSTALLATION DUTIES

flexibility within the local fleets and were ultimately superseded in the mid 1930s, along with some 10 cwt and 1-ton types, by a smaller range of more versatile designs of 1-ton capacity.

It was not until 1960 that the first of a new family of 15 cwt vehicles was introduced into the engineering fleet. The modern 15 cwt designs contrast sharply with their predecessors, being conversions of mass-produced light commercial vehicles, and equipped to ensure that they can be utilized for a number of different duties. A total of 1,100 of the new 15 cwt engineering vehicles is already in service, with the expectation that the number will almost certainly exceed 2,100 in the next two or three years, as superseded 10 cwt vehicles are replaced. Obviously, the high total capital cost of such a large section of the engineering fleet makes it essential that the conversions of the basic commercial vehicles should be as economical as is practicable. On the other hand, the facilities offered by the vehicles must be adequate to

exploit to the maximum the sphere of use of this relatively light and economical type of vehicle. Hence, a correct balance between these main considerations is essential, and the initial balance must be rechecked periodically in the light both of developments in commercial vehicles and in telecommunications field-work.

1960 15 CWT STANDARD VEHICLES

The 15 cwt Utility Vehicle

The immediate predecessor of the 1960 15 cwt Utility vehicle was one of 10 cwt capacity. While the 10 cwt Utility vehicle¹ fully justified its adoption in 1953 by meeting, with maximum economy, the transport needs of many light 2-man working parties, it became readily apparent after a few years use that its capabilities fell just short of the requirements of many more such working parties. However, it was not until 1959 that a suitable 15 cwt standard commercial van (the British Motor Corporation (B.M.C.) J2 van) became available as the basis for an improved light utility vehicle. Its subsequent adaptation as a Post Office 15 cwt engineering Utility vehicle is described in an earlier article;² it was introduced into regular service in 1960 to serve as a replacement for the 10 cwt Utility vehicle and for use on many of the lighter duties which had hitherto required 1-ton Utility vehicles.

The new Utility vehicle had its shortcomings, some of which were apparent from the outset; others came to light after a number of vans had seen some 12 months regular service. Indeed, it did not really have as much appeal to the staff using it as was at first hoped. Nevertheless, it undoubtedly made a valuable contribution towards equipping the Utility fleet with vehicles of a lighter type than had previously been used and this resulted in savings in motor-transport costs.

One of the main attractions of the 15 cwt van, its commodious body compartment (9 ft long, 5 ft 7 in. wide, 5 ft 1 in. high), also proved, ironically enough, to be a factor contributing to some difficulties and criticisms; Fig. 2 illustrates this long body compartment complete with rack fittings. It will be appreciated that, although the rack units are arranged to the best advantage, it is necessary to clamber into the body and move up the central gangway to gain access to the forward end of the body storage-space. Although this difficulty has been eased by an extra 3½ in. of head room given by a special translucent fibre-glass roof in place of the standard metal roof, insufficient head room is still a prevalent staff complaint; the need to stow large items in the gangway space, thus restricting or obstructing free access, also inevitably aggravates the effect of insufficient head room.

The external ladder rack, designed to accommodate a long 2-section extension ladder (Ladder, Extension, No. 1, 14 ft long when closed) is centrally mounted on

†External Plant and Protection Branch, E.-in-C.'s Office.

¹SLATER, G. H. A New 10 cwt Utility Vehicle. *P.O.E.E.J.*, Vol. 46, p. 86, July 1953.

²THOMAS, A. W., and COLLINGS, E. R. Four New Engineering Vehicles. *P.O.E.E.J.*, Vol. 53, p. 257, Jan. 1961.

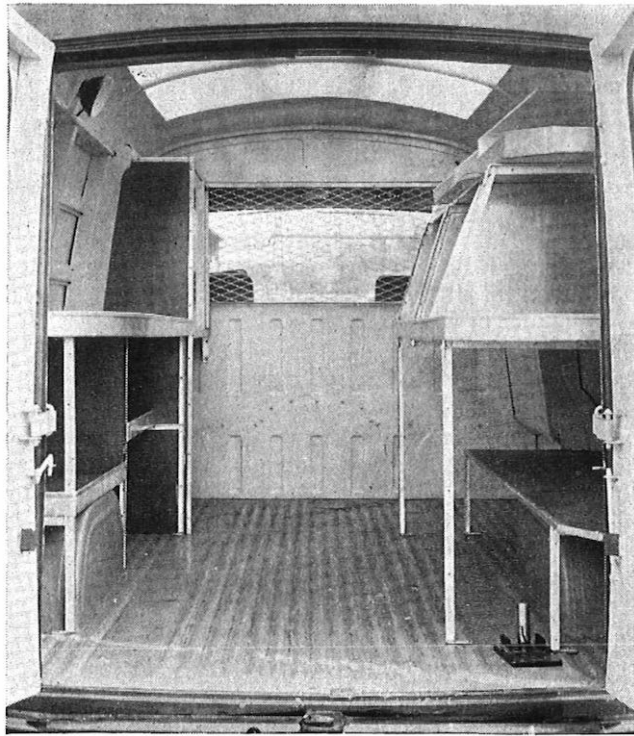

FIG. 2—INTERIOR OF 1960 15 CWT UTILITY VEHICLE

the roof to maintain the balance of the vehicle. Consequently, it is necessary to resort to a mechanical securing clamp, remotely controlled from the rear of the rack, to secure the forward end of the ladder, which cannot be reached by a man standing on the ground. Also, the relatively high ladder-rack position necessitates a special loading and unloading technique. But perhaps the most disappointing feature was that it was impracticable to provide safely for the carriage of a short 3-section extension ladder on the external ladder rack. Such an extension ladder has to be carried within the off-side internal racking, sometimes occupying space that could otherwise be used instead of gangway space so enabling the latter to be kept clear.

The internal rack units are of light-alloy construction and are divided up by fixed partitioning into graduated compartments. A more flexible arrangement of the standard internal fittings is sometimes thought desirable by users of the vehicle although the nature and degree of this flexibility cannot readily be defined.

While the adaptation of the B.M.C. J2 van produced a much cheaper vehicle than the larger coach-built 1-ton or 25 cwt Utility vehicles, it was still, nevertheless, expensive in comparison with other conversions of commercial vans for engineering purposes. Analysis of the conversion costs showed the main expense to be the provision of the fibre-glass roof and the ladder rack. Another relatively expensive departure from the commercial standard was the substitution of a double-leaf door of fibre-glass in place of the standard single rear door. The object of this was to reduce the space required to open the rear door and so improve the suitability of the vehicle for working in places where parking space is limited.

The 15 cwt Stores-Carrying Vehicle

The 15 cwt stores-carrying vehicle is equipped with the

same type of body as the Utility version except that the ladder rack and internal rack units are not provided, and a single narrow near-side door is added to the body section; the side door, a standard commercial extra, greatly enhances the usefulness of the vehicle when delivering to premises in localities subject to parking congestion. The vehicle as initially issued had a clear body-space because it was considered that the major use for the vehicle would be to cater for the light general-purpose element of the work of centralized pools of stores-carrying vehicles and for other duties for which no fittings are required. Nevertheless, the vehicle is also very suited to apparatus-delivery work for which simple storage racking is usually desirable. Such requirements for racking are met by the local installation of suitable light racking, as and when required, using modern patent, light, slotted-angle, metal-work. Occasionally the vehicle is used for electric-light-and-power installation work, or by a foreman joiner supervising a group of jointers equipped with tool-cart trailers; the ability to tow or transport small mechanical aids goes a long way towards making such a group self-contained.

THE BASIS FOR FURTHER IMPROVEMENT

Routine attention to developments in the commercial-vehicle field enabled most of the previously mentioned shortcomings of the 15 cwt Utility vehicles to be eliminated and substantial savings in capital costs to be made. By utilizing double side doors on the near-side, which became available commercially as an optional extra, easy access is given to the front of the body section and this almost eliminates the need to clamber into the body. This in turn means that it is possible to dispense with the specially heightened roof, to simplify the relatively complicated external ladder rack and to dispense with the special double-leaf rear door. It was estimated that the cost of the 15 cwt Utility vehicle could be reduced by over 11 per cent in this way and the stores-carrying version by half that amount. A further advantage is the improvement in convenience when working in locations where parking is difficult.

1963 15 CWT STANDARD VEHICLES

The 15 cwt Utility Vehicle

Fig. 3 illustrates the improved 15 cwt Utility vehicle, the B.M.C. J2 van with double-leaf side door and a simple ladder rack on the roof; the illustration shows the generous span of the double-leaf side door, the leaves of which can be swung fully back against the side of the vehicle to minimize possible obstruction of the footpath. In adopting the double-leaf side door it is necessary to resort to hinged cab doors in place of the original sliding doors and to accept the attendant accident risk of an incautiously opened cab door. The large single rear door is restrained at 90 degrees from the closed position to prevent it swinging out into the traffic stream by accident; it can be propped open in this position by means of a simple stay.

Taking advantage of the unbalanced internal-rack layout inherent in the near-side loading arrangement, the ladder rack has been off-set to the near-side of the roof, so that even a man of modest stature can reach a securing strap at the front, rear or centre of the ladder rack by standing in one of the doorways. This degree of accessibility, together with a ladder-rack height some

4 in. lower than on the previous model, allows the use of the simple horizontal type of ladder carrier already commonly used on Minor vans. A 2-section extension ladder of 14 ft closed length, or a small 3-section alloy extension ladder can be accommodated on the external ladder rack; these ladders can be loaded and unloaded manually in a straightforward manner. How-

is considered that, for the smaller man, this manoeuvre is sufficiently awkward to avoid resorting to it if possible.

Within the body section simple partitioned racking is arranged round the sides and utilized in such a way as to keep to a minimum the need for a man to climb into the body. Fig. 4 shows, from the near-side, the internal racking loaded with the equipment and stores for a small working



FIG. 3—1963 15 CWT UTILITY VEHICLE

ever, it is intended that the short 3-section ladders should be carried on the ladder rack on the roof only if the load or equipment carried inside the body prevents the ladder being placed on an internal shelf provided for the purpose; a small ladder tends to be something of a “dead weight” when being loaded on to the roof rack, and it

party engaged on subscribers’ apparatus installation and light overhead-construction work. Fig. 5 shows the layout from the rear. These illustrations depict the initial experimental racking, which utilizes 1½ in. slotted-angle metal work for the framing members. In the interests of flexibility the same system of rack construction has been specified for the initial contract, but the continued provision of this type of racking will depend on the degree of use made of its flexibility in service, balanced against the increase in cost compared with more orthodox construction. The shelves slope backwards to hinder the dislodging of equipment and stores when the vehicle is in motion. A 1½ in. fence rail is formed by the upturned front slotted-angle cross-member.



FIG. 4—SIDE VIEW OF INTERIOR OF 15 CWT UTILITY VEHICLE

An internal ladder-shelf above the off-side rack unit can be used for the carriage of a small 3-section ladder (up to a length of 8 ft 6 in. when closed), sash line being used to secure the ladder in position. Shelf-type ladder stowage has been chosen largely to avoid wear and tear on the ladder; the securing ropes are required as much to prevent the stiles of an aluminium ladder fretting on the ladder rungs as to prevent the ladder being dislodged in transit. Also, a shelf lends itself to supplementary or alternative uses, e.g. the carriage of a step-ladder, hose sections or other long items. The height of this ladder shelf and the configuration of the racking underneath is arranged to allow the sections of a large jointing tent to be tucked under the leading edge, with the curved parts fully below the forward end of the shelf.

In general, the partitioning of racks into compartments has been graduated so that the largest compartments are in the off-side racking, space for digging tools being available below the off-side rack. The near-side com-



FIG. 5—REAR VIEW OF INTERIOR OF 15 CWT UTILITY VEHICLE

partments are of mixed sizes, and the smallest compartments are in the forward racking. However, this nominal setting of partitions can readily be rearranged if required, and it is intended that they should be subdivided as necessary by the local addition of extra partitioning. The top of the small forward rack forms a tray that can be used to set out small tools, while the clear space below this rack will accommodate a joiner's tool box. A number of key rack joints are gusseted, however, and should not therefore be disturbed when changes to the partitioning are made.

A propane-gas cylinder can be carried on either side of the rear door, the space on the off-side being for the standby cylinder and that on the near-side for the working cylinder. Each cylinder is secured by a strong webbing strap and, because commercial propane is heavier than air, is set over gas-drainage holes in the floor. Above the working cylinder is shelf accommodation for the gas stove and torch, with saddles above for the supply hoses. In this way the gas-plumbing equipment is stowed in a manner conducive to its safe use.

Above the off-side rack a slotted-angle member, running the length of the cant rail, carries a number of wire hooks. These hooks are intended for carrying coils of wire and cable; to prevent damage to wire due to movement in transit, the hooks will be of a special shape in the standard production vehicles and not the simple hooks depicted in Fig. 4. Protective clothing can be hung on

a further two hooks at the forward end of the near-side rack unit.

The vehicle is fitted with a towing hitch and can tow, over normal road gradients, a fully-laden tool-cart trailer or other trailer up to a gross trailed load of 12 cwt. An auxiliary fitting for use with the towing hitch is a small mounting plate for a 3 in. vice; Fig. 5 shows this vice in position. The remaining features and facilities are identical with those on the earlier model and follow orthodox practice.

The 15 cwt Stores-Carrying Vehicle

The new 15 cwt stores-carrying vehicle consists of the same basic commercial B.M.C. J2 van with double side doors as its Utility counterpart, the only addition to the commercial van being a towing hitch, standard Post Office security arrangements and the normal Post Office miscellaneous additions to the cab equipment. As with its predecessor, any rack-unit required will be provided locally.

The 15 cwt Personnel Carrier

Circumstances such as difficulty in obtaining lodgings, poor public-transport facilities and other staff welfare problems sometimes give rise to a situation in which, for an appreciable period, a number of Utility vehicles daily traverse almost identical routes to locations relatively close together within the area of a particular major project some distance from the headquarters of the staff concerned. Depending on the number of vehicles, the number of staff and the distances involved, it is sometimes more economical to operate the Utility vehicles from a temporary out-station headquarters within the exchange area or areas concerned and to provide a personnel-carrying vehicle for the common portion of the

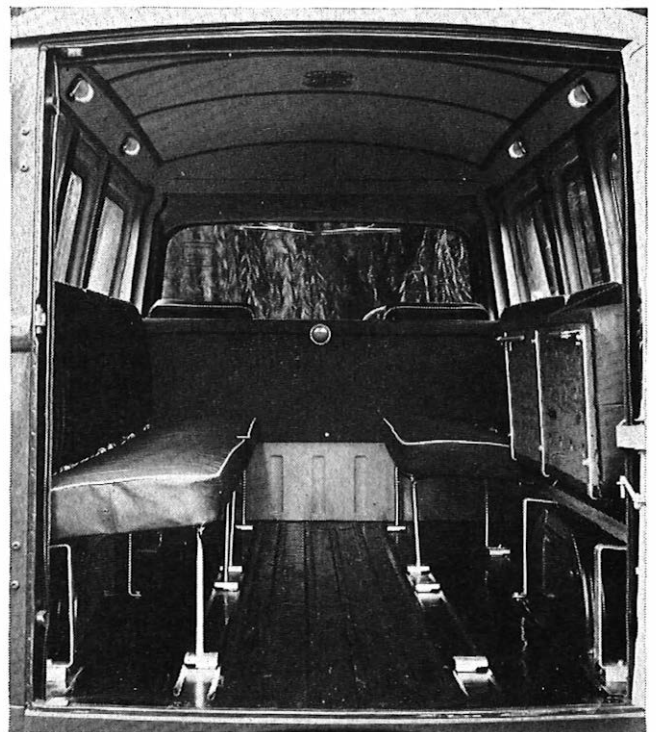

FIG. 6.—INTERIOR OF 15 CWT PERSONNEL CARRIER

daily journey to and from the normal headquarters. When the incidence of the need for personnel-carrying was small, the hiring of a suitable passenger-carrying vehicle sufficed, but Regional needs grew to such an extent that, by 1958, there were some 23 personnel-carrying vehicles in the engineering fleet. These personnel carriers were conversions of a 25 cwt Seddon stores-carrying van having a fibre-glass body and a 2.2-litre diesel engine; the conversion consisted of fitting fixed side-windows, longitudinal tip-up seats along each side of the body, and ventilators. Unfortunately the 14-seat Seddon personnel carrier was not popular with staff because of the lack of comfort; it was a relatively expensive vehicle, and was, perhaps, slightly larger than necessary. A cheaper and more satisfactory alternative was found in the B.M.C. Minibus.

The Minibus is another of the B.M.C. family of J2 vehicles, being a mass-produced adaptation of the basic J2 van shell; windows are fitted along the full length of both sides of the body, the rear-most being openable for ventilation. It is available in alternative internal layouts; that shown in Fig. 6 was adopted, without any special modification, for engineering service. For such service the seating capacity is 12 men inclusive of the driver. It will be seen from Fig. 6 that the rear seating is arranged in four sections, each of which can be tipped up and secured against the side of the vehicle by a strap,

the seat props being folded back and held in spring clips. Such a seating arrangement enables the vehicle to be used for light stores-carrying work between personnel-carrying journeys, and it has been used very effectively as the mobile base for a large group of exchange-conversion fitters carrying out a highly concentrated street-by-street program. Internal lighting and roof ventilators complete the fittings of the lined body interior, which is trimmed with a plastic material.

The justification for resorting to personnel-carrying depends on particular circumstances, and, therefore, the requirements for personnel-carriers also depend on the incidence of such circumstances. Hence, the dual-purpose nature of the vehicle enables it to be more fully employed at times when it is not being wholly utilized for passenger-carrying. Twenty-six of the 15 cwt personnel carriers are already in service and there are plans for a further number to be provided, which will raise the total to an average of at least one per Telephone Area.

CONCLUSIONS

Without question the new 15 cwt vehicles can give material savings in capital cost compared with their immediate predecessors. Their improved facilities increase the possibility of 15 cwt vehicles supplanting larger types on an even wider range of duties.

Book Reviews

"Electrical Instruments and Measurements." 2nd Edition. W. Alexander, M.Sc.(Eng), Ph.D., M.I.E.E. Cleaver-Hume Press, Ltd. 350 pp. 113 ill. 25s.

This is the second edition of book No. 5 in the Cleaver-Hume electrical series of text books. It covers the fundamentals of the subject and its study requires only an elementary knowledge of mathematics. The principles, construction and methods of operation of the various types of a.c. and d.c. ammeters, voltmeters and wattmeters, together with methods of extending their ranges, occupy the first four chapters. Brief descriptions are given in the next two chapters of the copper oxide rectifier for instrument use, clip-on ammeters, recording instruments and multi-range test sets. These are followed by explanations of the principles of power-factor meters and frequency meters, methods of measuring power, and descriptions of the types of energy meter on the market. The main commercial tariffs are quoted, and industrial meters and their installation are described. Two chapters very adequately cover the testing of instruments and meters, and another, the methods of measuring resistance. The final two chapters deal with the testing and inspection of electrical installations in buildings, and, although quite adequate for a book of this type, are not sufficiently clear in certain essentials. In regard to insulation-resistance testing it is not stated that the formulae quoted for both incomplete installations and for completed installations are not applicable to p.v.c. cable, a great deal of which has been installed in recent years. It should also have been stated that, in spite of the formula quoted, the insulation resistance value is subject to a minimum of 1 megohm for a whole installation.

The book is clearly written and printed. The diagrams and illustrations are well chosen, and some of the chapters are increased in value for students by the inclusion of a number of worked-out examples. In addition, there are about 100 test questions at the end of the book, one third of which are numerical and have the answers given.

The book should be of great help to students in technical colleges studying for Intermediate City and Guilds and similar examinations.

R.S.P.

"International Series of Monographs on Electromagnetic Waves. Ionospheric Sporadic E." Edited by Ernest K. Smith, Jr., Ph.D., and Sadamis Matosishita, Dr. Sc. Pergamon Press, Ltd. xiii + 391 pp. 196 ill. 105s.

The fact that a volume such as this could be prepared covering the characteristics of only one—and that not the best understood—of the regions of the earth's ionosphere is evidence of the large amount of work carried out in recent years by ionospheric physicists. In the main, the book divides into three parts, the first comprising separately reported results of experimental observations of vertical-incidence, oblique incidence and back-scatter reflections from the sporadic-E region. The data from near-equatorial latitudes form a particularly welcome addition to the literature. This is followed by a series of papers providing the results of the analysis of routine data obtained at ionospheric sounding stations, some of it during the International Geophysical Year. Finally, a section is devoted to new theories of the formation of the sporadic-E region.

The radio-communications engineer will find this volume of value only for reference purposes. Those few papers which give results of observations analysed on a statistical basis will prove of interest and some limited application for frequency-planning purposes. Possibly the most useful papers to the engineer are those in an introductory section which provides a synthesis of knowledge of occurrence of the various forms of sporadic-E propagation over the world. It is unfortunate, however, that the contour values and the legends on the maps provided by E. K. Smith are so compressed as to be almost unreadable. Apart from this, the standard of reproduction of the many illustrations in the book is high.

J.K.S.J.

Inauguration of the Commonwealth Pacific Cable (COMPAC)

U.D.C. 621.395.741:621.315.28

DURING the evening of 2 December 1963 the Commonwealth Pacific Cable (COMPAC), the second stage of the Commonwealth "round-the-world" telephone-cable system, was officially opened by Her Majesty the Queen. Her Majesty's recorded message was followed by an exchange of greetings between the Prime Ministers of Great Britain, Canada, New Zealand and Australia.

The COMPAC cable project, which links Australia with Canada via New Zealand, Fiji and Hawaii, is a joint financial enterprise between Britain, Canada, New Zealand and Australia, and was the outcome of a series of discussions held in Sydney in 1959.¹ A Management Committee, consisting of a representative from each of the countries concerned, was formed under the Chairmanship of Mr. T. A. Housley, General Manager of the Australian Overseas Telecommunications Commission. The responsibility for the design and development of the system was vested in the COMPAC Development Group headed by Mr. R. J. Halsey, Director of Research, British Post Office. The Development Group was able to call upon the full technical resources of the British Post Office, Cable and Wireless, Ltd., and the other Commonwealth partners associated with the project.

The COMPAC project was constructed in four stages. The first section between Australia and New Zealand was completed in June 1962, and the section New Zealand to Fiji in November 1962. The cable-laying operations for the sections Fiji to Hawaii and Hawaii to Canada were completed in October, 1963. Immediately following completion of the laying operations of each section there was a period of intensive testing during which the section operating levels were set to give the design margins against overload and noise.

The majority of the cable used in the COMPAC system is the new type of Lightweight deep-sea cable pioneered by the British Post Office and first used on the CANTAT transatlantic system.² H.M.T.S. *Monarch* and the C.S. *Mercury* were engaged in the laying of the COMPAC cable, and the C.S. *Retriever*, which laid certain shore ends, will be based in the Pacific to carry out repairs when needed. During laying operations by H.M.T.S. *Monarch* and the C.S. *Mercury*, equalizers were designed and constructed^{3,4} on the cable ships and inserted at intervals along the cable to maintain the system misalignment within design limits.

The section from Sydney to Vancouver Island comprises some 8,150 nautical miles (n.m.) of submarine cable and 318 submerged repeaters. The repeaters are spaced at intervals of 26.3 n.m. for the deep-sea sections and at 18 n.m. in shallow water. The two directions of transmission are separated into two frequency bands, 60–300 kc/s and 360–608 kc/s, each direction of transmission accommodating five 48 kc/s

groups. The transmission performance of the groups is such that either 12 channels (4 kc/s spacing) or 16 channels (3 kc/s spacing) per group may be used.

The cable can accommodate 80 telephone speech channels of 3 kc/s bandwidth. Many of the telephone channels will be used to carry multi-channel voice frequency telegraph systems, and data and facsimile transmissions. Facilities also exist for program and cable-film transmission. Circuits in the COMPAC system are extended to London, and thence to Europe, via a 3,000-mile trans-Canada microwave radio-relay system and the CANTAT transatlantic cable system, which was completed in December 1961.⁵

The longest group routed via the COMPAC cable is the 12-channel group between London and Sydney, a distance of about 16,000 miles. Dialling facilities⁶ are provided on the London to Sydney circuits, enabling London operators to call directly the majority of Australian subscribers, and operators at Sydney and other places throughout Australia to deal similarly with calls for Britain.

In the design, engineering and manufacture of the system the most important factor has been reliability, and the overall standards required have been of the highest order. The overall performance objectives for the COMPAC system were the same as for the CANTAT system.⁷ The noise objective, 1 pW/km in the busy hour averaged over all channels in each direction separately, was achieved on all sections of the COMPAC system.

The next stage of the Commonwealth telephone-cable system is the South-East Asian Commonwealth Cable (SEACOM) linking Australia with Jesseltown (North Borneo), Hong Kong and Singapore. Completion of the link from Singapore to Hong Kong and Jesseltown is planned for December 1964.

G.O.

References

¹Proposed Commonwealth Pacific Telephone Cable System. *P.O.E.E.J.*, Vol. 53, p. 42, Apr. 1960.

²BROCKBANK, R. A., CLARKE, E. F. S. and JONES, F. Anglo-Canadian Transatlantic Telephone Cable (CANTAT): Cable Development, Design and Manufacture. *P.O.E.E.J.*, Vol. 55, p. 82, July 1963.

³SCOWEN, F., TAYLOR, S. A., THOMAS, J. F. P., and WALKER, D. C. Anglo-Canadian Transatlantic Telephone Cable (CANTAT): Submerged Repeaters, Equalizers and Associated Terminal Equipment. *P.O.E.E.J.*, Vol. 56, p. 76, July 1963.

⁴SCOWEN, F. The Equalization During Laying of the Anglo-Swedish Submarine Telephone Cable. *P.O.E.E.J.*, Vol. 54, p. 48, Apr. 1961.

⁵HALSEY, R. J. CANTAT—A New Submarine Telephone Cable System to Canada. *P.O.E.E.J.*, Vol. 54, p. 220, Jan. 1962.

⁶WELCH, S. Line and Register Signalling Systems for Dialling over Transoceanic Telephone Cables. *P.O.E.E.J.*, Vol. 56, p. 111, July 1963.

⁷HALSEY, R. J. The Anglo-Canadian Transatlantic Telephone Cable System (CANTAT). *P.O.E.E.J.*, Vol. 56, p. 73, July 1963.

Calculation of Current Values for Determining Bus-Bar Sizes in Automatic Telephone Exchanges

R. C. KYME, A.M.I.E.E., and W. SCANLAN†

U.D.C. 621.316.35: 621.395.722

The methods at present used to determine the correct sizes for automatic telephone exchange bus bars are not entirely satisfactory. A method is therefore suggested that enables the current values to be determined in a more logical manner than has previously been attempted. A large number of tests have been made to check that figures deduced theoretically correspond closely to those measured on working equipment.

INTRODUCTION

THE method of distributing current to the various racks of apparatus that make up an automatic telephone exchange has changed little since the introduction of 2,000-type equipment.^{1,2} It may be useful, however, to describe very briefly these arrangements and, in particular, to define the terms used for the various parts of the system.

Power is fed to the equipment racks at a nominal 50 volts. Each rack has, on one side, a pair of bus bars running from top to bottom; one bus bar is insulated and at a potential of -50 volts with respect to the other, which is at earth potential. Power supplies to individual shelves or items of apparatus are fed from the negative bar via separate fuses whilst the various earth feeds are distributed from the earth bar. These two $\frac{1}{2}$ in. \times $\frac{1}{4}$ in. bars are known as the rack bus bars and are made of nickel-plated hard-drawn copper or brass.

The rack bus bars are connected to a pair of bus bars running along the top of each apparatus rack. These are of hard-drawn copper or aluminium, $\frac{3}{4}$ in. \times $\frac{1}{4}$ in., and are known as inter-rack bus bars. A similar pair,

known as inter-suite bus bars, is used to connect the inter-rack bars if more than one suite of racks is served from a single tee off the sub-main bus bars.

The negative inter-rack or inter-suite bus bar is connected via a group fuse (125 amp rating) to the sub-main bus bar, which is paired with an earth bar of similar size. The sub-main bars are connected by main feeders to the power switchboard and are situated over the main gangways of the apparatus room in such a way that the inter-rack bars may conveniently be connected. The main feeders and sub-main bus bars are of hard-drawn aluminium and of such a size that the total voltage drop in the distribution leads (feed and return) between the battery terminals and any rack fuse mounting does not exceed 1 volt under full-load conditions. The arrangement of the various bus bars is shown in Fig. 1.

PRESENT METHOD OF DETERMINING FULL-LOAD CONDITIONS

Several attempts have been made to compile a table of the maximum current taken by each type of apparatus rack in an automatic telephone exchange. One of these tables is at present used as the basis for calculations to determine full-load conditions for actual exchanges. The equipment load is divided among a suitable number of group fuses, and the maximum current per group fuse is derived from the tables by aggregating the loads shown for each rack served by the group fuse. No attempt is made to introduce a diversity factor within the group, except for 1st code selectors and group selectors; for these two types of equipment a simple formula is used to decrease the current allowed per rack as the number of racks increases.

A diversity factor to reduce the current when calculating sub-main and main bus-bar sizes is obtained by dividing the busy-hour load quoted in the contract specification by the maximum load derived from the ultimate number of racks. The current assumed to be flowing in the sub-main bus bars is not therefore simply the sum of currents of all groups fed from those bars, but is this sum multiplied by the diversity factor, a typical figure being 0.3.

This method, or a variation of it, is used by the equipment contractor to calculate bus-bar sizes for each exchange. It is entirely empirical and is inexact. Moreover, it is not specified in any contract document, and there are no means of checking that an exchange has bus bars of the correct size.

CURRENT LOAD OF AN AUTOMATIC TELEPHONE EXCHANGE

The current taken by automatic-exchange equipment varies from moment to moment. The general pattern of the load throughout the day is well known: it rises to a maximum in the morning, falls off at lunchtime, rises to a peak—usually lower than the morning peak—in the afternoon, then falls again in the late afternoon, with perhaps an evening peak, and drops to a very low value

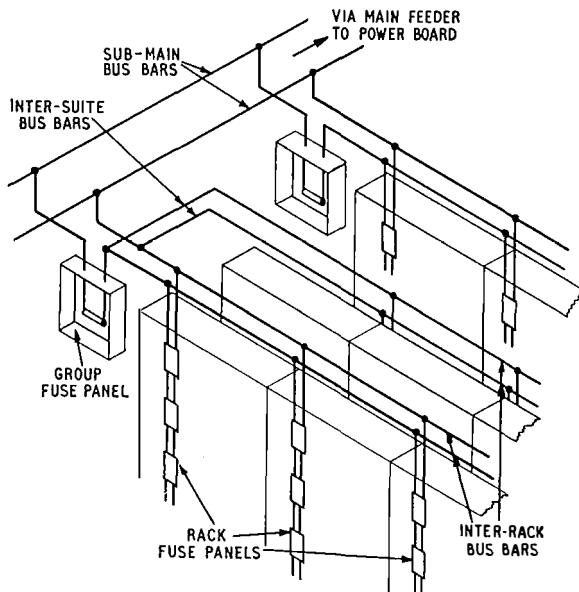

FIG. 1—TYPICAL BUS-BAR ARRANGEMENT

†Mr. Kyme is in the Engineering Branch, South-Western Region, but was formerly in the Exchange Equipment and Accommodation Branch, E.-in-C.'s Office. Mr. Scanlan is in the latter Branch.

during the night. Weekly and yearly patterns are also recognizable. Such information is necessary for deciding power-plant capacity but is not good enough for calculating bus-bar sizes. For the latter purpose it is necessary to consider short-term maximum currents.

The conventional automatic telephone exchange consists largely of a variety of individual equipment items each of which, during use, draws a varying current, and the number of items simultaneously in use is dependent on the number of calls being handled. The current at any instant, therefore, depends partly on the number of calls in progress and partly on the particular operation being performed by each piece of equipment in use at that instant.

The traffic ultimately to be carried is something which must be forecast before an exchange is designed, and the amount of equipment eventually to be provided is therefore known. The average traffic to be carried by each rank of switches during its busy hour is also known, but whilst, for instance, a rack of 80 group selectors forming part of a 240-trunk grading carrying smooth traffic at a grade of service of 0.005 has, on average, 60 selectors engaged throughout the busy hour, at any instant all 80 switches may be engaged or none may be engaged. Of any number which may be engaged the relays and magnets operated will vary according to the stage reached by each call.

A selector consumes most current when a magnet is operated, and it is possible, although highly improbable, that every selector on a rack could be in this state simultaneously. This would entail a very heavy current drain. An exchange is composed of many racks of equipment each of which has a maximum current consumption, and whilst the likelihood of any rack taking its absolute maximum current is remote, the probability of all racks simultaneously consuming maximum current is still more remote. Somewhere below the very large figure which would be obtained by aggregating the maximum currents which it is possible for each rack to take must be a value that can reasonably be used in bus-bar calculations. It is the purpose of this article to suggest a method by which this current value may be determined logically, based on a better understanding of the problems involved.

To check, as far as possible, the figures deduced theoretically, a large number of tests have been made on working equipment. These tests have included recordings of the current taken by individual items of equipment and by subsections, together with simultaneous records of traffic carried by the equipment. After allowance has been made for incompletely equipped racks and for traffic conditions below the maximum for the designed grade of service, the practical results show, in each instance, very close correspondence with the figures produced theoretically.

METHOD OF CALCULATING CURRENT FOR INDIVIDUAL RACKS

For the purpose of the calculations three types of equipment have been recognized:

- (a) selectors,
- (b) short-holding-time equipment, e.g. directors, and
- (c) relay-sets and miscellaneous apparatus.

To demonstrate the principles, 4,000-type³ group-selector racks will be used as the example.

The first step was to analyse the selector functions to see how much current was taken at each of the various stages and the duration of each stage. In doing this a number of assumptions had to be made, and in preparing Table 1, which shows an analysis of a call

TABLE 1
Analysis of Average 4,000-Type Group-Selector Call

Stage of Call	Duration (seconds)	Current (mA)	Weighted Average Current (mA)
Seizure	0.650	206	$\frac{0.65 \times 206}{144} = 0.93$
Vertical stepping (magnet operated)	0.330	1,209	$\frac{0.33 \times 1,209}{144} = 2.80$
Vertical stepping (magnet released)	0.165	466	$\frac{0.165 \times 466}{144} = 0.53$
Release of relay CD	0.100	456	$\frac{0.1 \times 456}{144} = 0.32$
Rotary stepping (magnet operated)	0.080	1,456	$\frac{0.08 \times 1,456}{144} = 0.81$
Rotary stepping (magnet released)	0.080	472	$\frac{0.08 \times 472}{144} = 0.26$
Conversation	142.415	82	$\frac{142.415 \times 82}{144} = 81.08$
Release (magnet operated)	0.100	1,000	$\frac{0.1 \times 1,000}{144} = 0.69$
Release (magnet released)	0.080	—	—
Total duration = 144.000		Total weighted average current = 87.42	

handled by a group selector, it was assumed that the length of the call was 144 sec (the national average) and that the selector was stepped to level 5 and that it hunted to the fifth contact in that level before switching to a free outlet.

The total weighted average current* is the average current per erlang, and a fully equipped rack carrying 60 erlangs would take an average current of 5.25 amp. This average current value is used later to calculate the peak current in main and sub-main bus bars.

It can be seen that when the vertical, rotary or release magnets are operated the selector is taking a much higher current than during its other functions. Two states have thus been recognized and are referred to here as the "high" and "low" current states. The high-current state has a duration of 0.51 sec and the weighted average current during this time is 1.203 amp. Similarly the

*Weighted average current—the current value adjusted to take account of the duration of that current relative to the average length of a call.

low-current state exists for 143.49 sec at 0.083 amp.

The total current taken by a rack of selectors at any instant is the sum of the currents taken by the individual switches engaged at that instant. This number varies from moment to moment, and of the switches engaged at any one time some will be in the high-current state and some in the low.

The probability of a certain number of events taking place when the average number of occurrences is known is given by the Poisson Distribution. Applying Poisson's formula to the present case, the probability of y switches on a rack being engaged when the average engagement is 60 is

$$P_y = \frac{e^{-60} \times 60^y}{y!}$$

The probability that out of y selectors in use, x are in the high-current state is

$$P_x = \frac{e^{-H} \times H^x}{x!}, \text{ where } H = \frac{y \times 0.51}{144}$$

Bernoulli's Law could be used for this latter calculation, since no more than y selectors could ever be in the high-current state. However, the more difficult calculations that would be introduced for only a very small increase in accuracy are not thought to be justified.

The probability of y switches being engaged and at the same time x being in the high-current state is $P_x \times P_y$. Table 2 shows a series of these calculations for values of y between 71 and 80 when $x = 1$.

TABLE 2
Sample of Results for Group Selectors

y	P_y	P_x (when $x = 1$)	$P_y \times P_x$	Accumulative Sum of $P_y \times P_x$	Equivalent Current Value (amp)
80	0.00218	0.213	0.000465	0.000465	7.793
79	0.0029	0.212	0.000615	0.001080	7.709
78	0.0039	0.210	0.000810	0.001890	7.626
77	0.0050	0.208	0.001040	0.002930	7.543
76	0.0064	0.206	0.001320	0.004250	7.459
75	0.0081	0.204	0.001650	0.005900	7.376
74	0.0101	0.202	0.002040	0.007940	7.292
73	0.0125	0.200	0.002500	0.010400	7.209
72	0.0152	0.198	0.003040	0.013480	7.126
71	0.0183	0.196	0.003600	0.017080	7.042

The last column of Table 2 gives the current that the rack requires in each condition, e.g. with 71 selectors in use, of which one is in the high-current state, the current taken is 7.042 amp. The probability of this current being exceeded, considering only one switch in the high-current state, is the sum of all the products $P_x \times P_y$ from $y = 72$ to $y = 80$, i.e. 0.01348. Similarly the probability of 7.376 amp being exceeded is

$$\sum_{y=76}^{80} P_x \times P_y$$

Fig. 2 shows four curves that have been plotted from calculations similar to those in Table 2, using values of $x = 0$, $x = 1$, $x = 2$ and $x = 3$, together with the curve obtained by adding the ordinates of the other four curves to give the total probability P_r of a certain current being exceeded, i.e.

$$P_r = \sum_{y=76}^{80} [P_y P_0 + P_y P_1 + P_y P_2 + \dots \text{etc.}]$$

where P_0, P_1, P_2 , etc., are values of P_x when $x = 0, 1, 2$, etc. In this particular instance values of x beyond 3 gave probabilities so small as to be negligible.

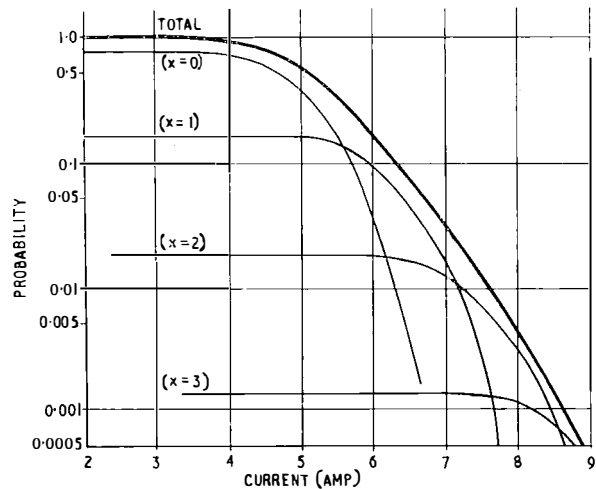

FIG. 2—PROBABILITY CURVES FOR ONE RACK OF GROUP SELECTORS

APPLICATION TO VARIOUS ITEMS OF EQUIPMENT

Two-Motion Selectors

Table 3 shows the currents taken by 1, 2, 3, 5, 8, 12 and 16 racks of group selectors at a probability of 0.005.

TABLE 3
Calculated Current Values for Racks of Group Selectors

Number of Racks	1	2	3	5	8	12	16
Maximum current in amp (probability of this current being exceeded = 0.005)	7.85	14.04	20.15	31.5	48.5	70.7	92.7
Increment per rack	—	6.19	6.11	5.67	5.66	5.55	5.50

These values have been calculated by computer using the method outlined above. It will be seen that whilst the first rack takes 7.85 amp at the chosen probability, the additional current due to each subsequent rack is appreciably less, and that the current increment per rack tends to a constant figure.

Calculations for 1st code selectors and final selectors show a similar pattern, and the amount of deviation from a constant-current increment per added rack is even less. This is an important general result, since only a small error results if the current for one rack is used together with a constant increment for each additional rack.

Table 4 illustrates the effect of drawing a straight line through the points if a graph is plotted of currents

TABLE 4
Current Values for Racks of Group Selectors Using a Constant Increment

Number of Racks	1	2	3	5	8	12	16
Estimated current (amp)	8.3	14.0	19.7	31.1	48.2	71.0	93.8

against the number of racks of group selectors (see Table 3). The same method gives the following figures for (a) 1st code selectors, and (b) final selectors, respectively:

- (a) 1st rack = 15.25 amp, increment = 11.75 amp.
- (b) 1st rack = 14.34 amp, increment = 11.03 amp.

Subscribers' Calling Equipments

The use of 50-point linefinders⁴ makes a simple method of stating the current requirements of subscribers' unselector racks impossible. It has, therefore, been necessary to consider first, racks of unselectors not associated with linefinders and, secondly, unselectors in association with linefinders. With the latter arrangement, account must be taken of the ratio of linefinder to unselector racks, which varies according to the requirements of particular exchanges, and has a considerable influence on the current taken by the unselector racks.

Table 5 gives an analysis of the operation of a subscriber's line-circuit during an average outgoing call. To

TABLE 5
Current Taken by a Subscriber's Line-Circuit During Each Stage of a Call

Stage of Call	Duration (seconds)	Current (mA)	Weighted Average Current (mA)
Seizure	0.05	59	0.020
Hunting (magnet operated)	0.30	559*	1.165
Relay K operating	0.02	36	0.005
Switching	10.00	36	2.500
Conversation	133.32	36	33.330
Relay K releasing	0.01	36	0.003
Homing (magnet operated)	0.30	500*	1.042

Total duration = 144.00 | Total weighted average current = 38.065

*These represent the high-current portion of a call.

take account of the operation of the K relay during incoming calls the assumption was made that there were an equal number of outgoing and incoming calls during the busy hour. In all calculations, therefore, the average duration of a call was taken as 288 sec, during which the unselector took high current for 0.6 sec and low current for 287.4 sec.

Table 6 shows the effect of the calling rate on the current drawn by a unselector rack. It was again found

TABLE 6
Effect of Calling Rate on the Current Consumption of Racks of Subscribers' Line-Circuits not Associated with 50-Point Linefinders

Calling Rate (erlangs)	Average Rack Current (amp)	Maximum Rack Current (amp) at Probabilities of	
		0.01	0.005
0.035	0.8	1.40	1.50
0.040	0.9	1.60	1.70
0.045	1.0	1.71	1.81
0.050	1.1	1.80	1.88

that at a given calling rate and probability it was necessary only to state the current requirements of one rack and the current increment for each additional rack.

When 50-point linefinders are used the traffic carried by a rack of unselectors increases considerably as the ratio of linefinder to unselector racks increases. The increased traffic per unselector rack is reflected in the increased current requirements and is shown in Table 7.

TABLE 7
Maximum Current for Subscribers' Line-Circuits Associated with 50-Point Linefinders

Unselector Rack-to-Linefinder Rack Ratio	Maximum Current (amp) at a Probability of 0.01						
	Numbers of Racks						
	1	2	3	4	5	6	7
1 : 0	1.4	2.3	3.2	4.0	4.9	5.8	6.6
1 : 1	2.0	3.3	4.5	5.8	7.0	8.2	9.4
1 : 2	2.3	4.0	5.7	7.3	9.0	10.6	12.2
1 : 4	3.2	5.6	8.0	10.4	12.8	15.2	17.6
1 : 6	4.0	7.2	10.4	13.6	16.8	20.0	23.2

The calling rate of subscribers connected directly to unselectors has been assumed to be 0.035 erlangs.

Short-Holding-Time Equipment

Directors are taken as an example of short-holding-time equipment and pose several problems not present in the examples previously considered. These are:

(a) Slight variations in the current and the duration of each stage of operation are more important because there is no long conversation period of constant current to reduce the effect of such variations.

(b) The number of digits dialled into the director varies.

(c) The number of translation digits sent out by the director varies.

(d) Average current values are affected by the length of the inter-digital pause, which varies according to the person dialling.

(e) There is a greater difficulty in differentiating between high-current and low-current states.

Average values have had to be assumed for (b)-(d) and trials have been made to determine the periods of high-current and low-current in (e).

The assumptions finally made are listed below:

(a) The digits dialled into a director are 55-5555.

(b) The translation is 555.

(c) The six inter-digital pauses (five between digits, plus seizure) have a total duration of 5.45 seconds.

(d) The holding time of the director is 14 seconds; this is 2 seconds less than the figure normally used in traffic calculations and takes into account the shorter holding time of code-only calls.

(e) The high-current state is 1.881 amp for 4.09 seconds and the low current state is 0.701 amp for 9.91 seconds.

Making these assumptions results in a theoretical figure for average current of 0.961 amp per erlang; this compares with 0.985 amp per erlang measured during a busy hour on a group of 23 directors. Table 8 shows an analysis of a call through a director.

At a probability of the current being exceeded of 0.005 the current consumption of one rack of directors was cal-

TABLE 8

Current Taken by a Director during Each Stage of Setting-up a Call

Stage of Call	Magnet Affected and Condition		S-Switch		Duration (sec)	Current (amp)	Weighted Average Current (amp)		
			Function	Magnet Condition					
Seizure (inter-digital pause)	—	—	—	—	1.05	0.300	0.022		
Subscriber dials "B" digit	Vertical	Operated Released	—	—	0.33	1.657*	0.039		
			—	—	0.17	1.091	0.013		
Inter-digital pause	—	—	—	—	1.20	0.300	0.025		
Subscriber dials "C" digit	Rotary	Operated Released	—	—	0.33	1.657*	0.039		
			—	—	0.17	1.091	0.013		
Inter-digital pause	—	—	Steps to outlet 2	Operated	0.13	1.032	0.010		
			Send first translation digit	Released	0.07	0.366	0.002		
			Drives to outlet 15	Operated	0.33	1.698*	0.040		
				Released	0.17	1.032	0.012		
Subscriber dials thousands digit	M Switch	Operated Released	Steps to outlet 20	Operated	0.33	2.384*	0.056		
			—	Released	0.17	1.152	0.015		
Inter-digital pause	—	—	Drives home	Operated	0.05	1.028	0.004		
			Steps to outlet 2	Released	0.05	0.362	0.001		
			Send second translation digit	Operated	0.13	1.032	0.010		
				Released	0.07	0.366	0.002		
Subscriber dials hundreds digit	C Switch	Operated Released Operated Released	Drives to outlet 15	Operated	0.33	1.698*	0.040		
			Steps to outlet 20	Released	0.17	1.032	0.012		
			—	Operated	0.05	2.318*	0.008		
				Released	0.05	1.086	0.004		
Inter-digital pause	—	—	Steps to outlet 20 (continued)	Operated	0.27	2.384*	0.046		
			Drives home	Released	0.13	1.152	0.011		
			Steps to outlet 2	Operated	0.07	1.094	0.005		
				Released	0.03	0.428	0.001		
Subscriber dials tens digit	D Switch	Operated Released Operated Released Operated Released	Drives home	Operated	0.05	1.028	0.004		
			Steps to outlet 2	Released	0.05	0.362	0.001		
			Send third translation digit	Operated	0.13	1.032	0.010		
				Released	0.07	0.366	0.002		
Inter-digital pause	—	—	Send third translation digit	Operated	0.27	1.698*	0.033		
			—	Released	0.13	1.032	0.010		
			Subscriber dials tens digit	Operated Released	Send third translation digit (continued)	Operated	0.07	2.988*	0.015
					Released	0.03	1.756*	0.004	
Subscriber dials units digit	U Switch	Operated Released Operated Released Operated Released	Drives to outlet 15	Operated	0.05	2.318*	0.008		
			Steps to outlet 20	Released	0.05	1.086	0.004		
				Operated	0.20	2.384*	0.034		
			Inter-digital pause	—	—	Steps to outlet 20 (continued)	Released	0.10	1.152
Drives home	Operated	0.13				1.094	0.010		
Steps to outlet 2	Released	0.07				0.428	0.002		
	Operated	0.05				1.028	0.004		
Subscriber dials units digit	—	—	Steps to outlet 2	Released	0.05	0.362	0.001		
			Send thousands digit	Operated	0.13	1.032	0.010		
				Released	0.07	0.366	0.002		
			Release	Release	Operated Released	Send thousands digit (continued)	Operated	0.20	1.698*
Drives to outlet 15	Released	0.10				1.032	0.007		
Steps to outlet 20	Operated	0.13				2.382*	0.023		
	Released	0.07				1.090	0.005		
Release	—	—	Drives to outlet 15	Operated	0.05	1.652*	0.006		
			Steps to outlet 20	Released	0.05	0.320	0.001		
				Operated	0.13	1.718*	0.016		
			Release	—	—	Steps to outlet 20	Released	0.07	0.486
Drives home	Operated	0.20				1.094	0.016		
	Released	0.10				0.428	0.003		
Release	—	—				Drives home	Operated	0.05	1.028
			Completion of sending (Aggregate of separate operations)	Released	0.05	0.362	0.001		
				—	—	4.20	—	0.314	
			Release	—	—	—	—	0.47	0.755
—	—	0.48				0.089	0.003		
					Total duration =	14.00	Total weighted average current =	1.047	

* High-current items totalling 4.09 sec at 1.881 amp weighted average current.

culated to be 24.0 amp, with an increment of 15.5 amp for each additional rack.

An interesting check on the theoretical calculations was made using the 23 directors mentioned above. The traffic carried by this group during the busy hour was measured as 2.813 erlangs. A recording ammeter with a paper speed of 12 in./min was used to record continuously the current during the same busy hour, and the current at each half-second was subsequently read, giving 7,200 readings. These current readings were grouped and a graph has been plotted (Fig. 3) showing the number of readings exceeding given values of current.

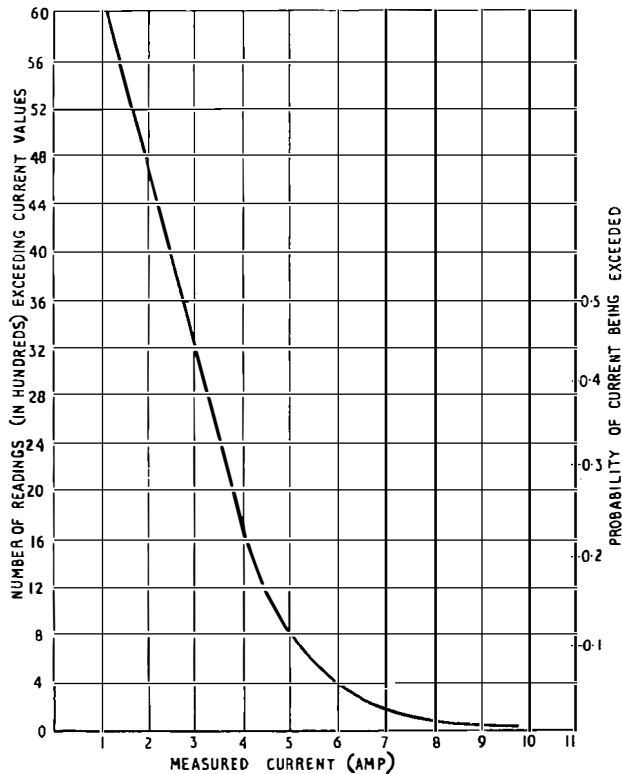

FIG. 3—DISTRIBUTION OF MEASURED CURRENT VALUES TAKEN AT 0.5-SECOND INTERVALS ON A GROUP OF 23 DIRECTORS

The probability of any particular current x amp being exceeded is thus

$$\frac{\text{The number of readings exceeding } x \text{ amp}}{7,200}$$

and Fig. 3 shows the values of probability for the higher currents.

Table 9 shows the comparison between the maximum current at a number of different probabilities calculated by the method described and the corresponding current read from Fig. 3.

Relay-Sets

It would be possible to treat relay-sets in a manner similar to that used for selectors. For the following reasons, however, such an approach is hardly practicable.

(a) There are a very large number of different types of relay-sets, and to provide separate figures for each would be laborious.

(b) Relay-sets of many different types are often fitted in the same exchange, some in very small numbers.

TABLE 9

Comparison of Calculated and Measured Current Values for a Group of 23 Directors Carrying 2.813 Erlangs

Probability Value	Current (amp) by Calculation	Current (amp) Read from Fig. 3
0.5	2.9	2.7
0.4	3.3	3.2
0.3	3.8	3.7
0.2	4.4	4.3
0.1	5.4	5.2
0.05	6.4	6.0
0.01	8.6	7.8
0.005	9.5	8.7

(c) Relay-sets of different types are usually associated together and served by one group fuse.

(d) Different types of relay-set are often mounted on the same rack.

The previous work on selectors has shown that the peak-to-average current ratios for any particular number of racks were very nearly the same for group, final and 1st code selectors. It seemed that it might be possible to use the mean of these ratios (Fig. 4) as a mul-

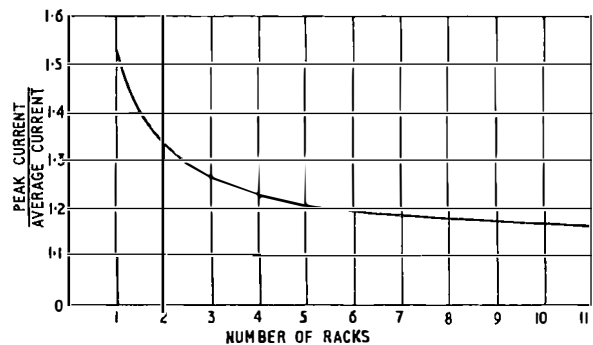

FIG. 4—MEAN PEAK-TO-AVERAGE CURRENT RATIOS FOR RACKS OF GROUP, FINAL AND FIRST-CODE SELECTORS

tiplying factor to convert average current to peak current for a particular number of relay-set racks.

A number of measurements were made during the busy hour with a recording ammeter to determine the average and peak currents carried by various group fuses serving relay-set racks. The individual average-current figures for each group fuse were aggregated and divided by the total number of racks in all groups to give an overall average busy-hour current per rack of approximately 8 amp.

A "best-fit" graph was calculated for the peak-current readings and the equation to this graph was found to be $y = 8.90x + 3.82$, where y is the peak current for x racks of relay-sets.

Table 10 shows the current values resulting from the use of this equation together with the peak-current values obtained by multiplying average current by the peak-to-average current ratios from Fig. 4. The results obtained by using the latter method may be expressed as $y = 9.07x + 3.17$ and these values correspond sufficiently closely with the former results to justify the use of the latter method for all relay-set-rack calculations except

TABLE 10
Peak-Current Values for Relay-Set Racks

Number of Racks	1	2	3	4	5	6	7	8	9	10	11
Peak current (amp) obtained by application of peak-to-average-current ratio to average-current value	12.24	21.31	30.38	39.45	48.52	57.59	66.66	75.73	84.80	93.87	102.94
Peak current (amp) from best-fit curve for practical current readings	12.72	21.62	30.52	39.42	48.32	57.22	66.12	75.02	83.92	92.82	101.72

where large numbers of similar relay-sets are grouped together, e.g. in London's automatic trunk exchanges. In such exchanges a more satisfactory method would be to calculate the peak-current values by the method already described for selectors. Miscellaneous apparatus racks may be regarded as equal to half a relay-set rack.

COMPLETE EXCHANGE

It was originally intended to assume an acceptable probability of the peak current in the main and sub-main bus bars being exceeded and to use the n th root of this probability to give the probability to be accepted for each group, where n is the number of group fuses. There are theoretical objections to this method, since the traffic handled by the equipment in each group is not wholly independent of the other groups. It was also desirable to make the calculations for each exchange as simple as possible.

It was, therefore, decided to take a continuous record during the busy hour of the discharge at a selection of exchanges to determine, for each, the average and peak currents. This was done at 33 exchanges of different type and varied sizes. When the resulting peak-current values were plotted against corresponding average-current values a nearly straight-line graph was produced. The "best-fit" curve (see Fig. 5) calculated for the results is defined by $y = 1.132x + 1$, where y and x represent peak and average currents, respectively. Since the constant term, 1, has negligible influence on the value of y ,

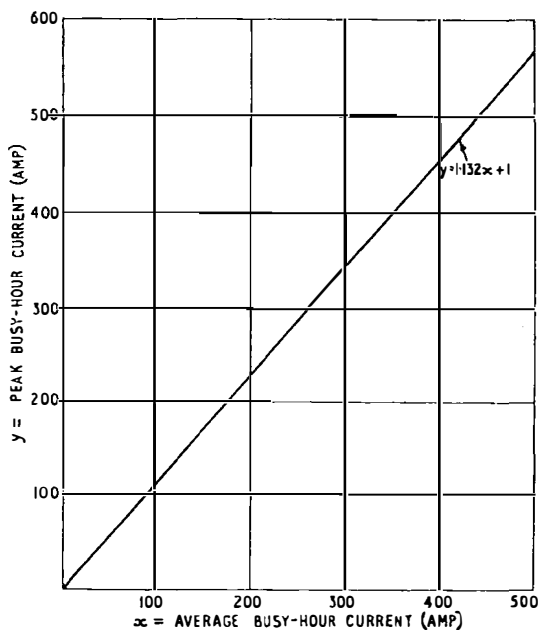

FIG. 5—BEST-FIT CURVE FOR DISCHARGE-CURRENT MEASUREMENTS TAKEN AT 33 EXCHANGES

the value of the peak current may be regarded as $1.132 \times$ average current.

It was shown earlier that for all racks above one, in any group of selector racks, the same allowance for peak current should be made. If the first rack is ignored the peak-to-average current ratios for various types of selectors and also for relay-sets are as shown in Table 11,

TABLE 11
Peak-to-Average Current Ratios for Racks of Various Types of Selectors

Type of Equipment	Rack Average Current (A) (amp)	Peak Current for Each Rack Additional to first Rack (B) (amp)	$\frac{B}{A}$
Group Selectors	5.22	5.70	1.091
Final Selectors	9.45	11.03	1.167
1st Code Selectors	10.26	11.75	1.146
Uniselectors	0.80	0.83	1.037
Relay-Set Racks	8.00	9.07	1.133

from which it can be seen that the ratios lie within the range of 1.037 to 1.167. The value 1.132 for a complete exchange lies well within this range. The effect of the higher peak current of the first rack in each group will tend to raise the overall peak current, but the non-coincidence in time of peak currents tends to lower the overall peak value. The use of the ratio 1.13 would, therefore, seem to provide a practical method for obtaining the value of the maximum current in the main and sub-main bus bars from the average current taken by each group of equipment.

CONCLUSION

Whilst certain generalizations and approximations have had to be made, it is thought that the above treatment represents a more reasoned approach to exchange current calculations than has hitherto been attempted, although some slight additions would be necessary before a working instruction could be issued to equipment engineers.

ACKNOWLEDGEMENT

The authors wish to acknowledge the help they have received from members of the Organization (Complements) Branch, E.-in-C.'s Office, in applying the Post Office Engineering Department's computer to the problem.

References

- ¹YOUNG, J. S. The Post Office 2,000 Selector. *P.O.E.E.J.*, Vol. 28, p. 249, Jan. 1936.
- ²WRIGHT, J. S., Distribution of Power in 2,000-Type Exchanges. *P.O.E.E.J.*, Vol. 33, p. 71, July 1940.
- ³PURVES, R. F., and WALKER, A. The 4,000-Type Selector. *P.O.E.E.J.*, Vol. 51, p. 168, Oct. 1958.
- ⁴FOX, W. H., ASHWELL, J. L. K., and WEAVER, A. L. Subscribers' 50-Point Linefinder System. *P.O.E.E.J.*, Vol. 51, p. 81, July 1958.

Connexions to Printed-Circuit Boards

K. W. HIX, A.M.I.E.E.†

U.D.C. 621.3.049.63: 621.3.049.75

The increasing use of printed-circuit boards for telecommunication equipment has emphasized the need for economical means of securing reliable connexions to the printed conductors; the problems involved in the provision of both permanent and separable connexions are reviewed. The various types of connexion in current use are described and the factors influencing their design are discussed.

INTRODUCTION

PRINTED-CIRCUIT boards are being increasingly used in the telecommunication industry for the accommodation of the multitude of small components—resistors, capacitors, rectifiers, transistors, etc.—from which modern equipment is built up. Considerable attention has been given to the design of this type of board, which consists essentially of a thin sheet of high-grade insulating material on which is laid or formed a copper pattern that is used to interconnect the circuit components. The components are assembled on the reverse side of the board to the pattern, with the conductor wiring tails projecting through holes in the board and soldered in position, frequently by an automatic flow-soldering process. The copper patterns can be produced by a variety of methods,¹ but in all instances the actual volume of copper used for the conductor is small and the conductors are more fragile than normal wire connexions; consequently, the problem of making external connexions to the board requires careful attention, and many methods have been used with varying degrees of success.

Whilst in theory there is no limitation to the area of the board and, indeed, boards of considerable size housing thousands of components have been produced, the requirements of mass-production processes and the physical limitations of board strengths have usually necessitated the use of relatively small boards for communication equipment. Therefore, to construct a functional unit it is normally necessary to interconnect a number of boards, and the security of the interconnexions becomes a vital factor in the success of the equipment. This article describes some of the methods that have been used for making connexions to printed-circuit boards employed on telecommunications equipment.

GENERAL CONSIDERATIONS

The copper laminate forming the conductor pattern on the surface of a $\frac{1}{8}$ in. or $\frac{1}{4}$ in. thick board of insulating material is normally not more than 0.003 in. thick, whilst conductor tracks as small as 0.060 in. in width are often used. A number of these tracks are brought together in parallel at the edge of the board for interconnexion purposes, and spacings of 0.10 in., 0.15 in. and 0.20 in. between centres of conductors are frequently used. To these conductors permanent wiring or plug-in units must be attached. Thus, a very small cross-section of conductor is available for

connexion purposes and, as low voltages and small currents are normally employed on the equipment, it is necessary to exercise considerable care in the physical design of the connecting media if reliable performance and long life are to be obtained from the equipment.

Whilst with some types of equipment it may be satisfactory to wire the printed-circuit board permanently in position, the convenience of the board as a unit for fault-locating and replacement purposes frequently results in the requirement of speedy removal and insertion of boards in working equipment. For this reason the printed-circuit board is often considered as a plug-in unit despite its inherent physical weakness, and the normal problems of making reliable separable connexions in the absence of suitable wetting currents arise;² this often makes the use of noble-metal contact materials on the connecting units inevitable.

METHODS OF CONNEXION IN GENERAL USE

A number of methods of both permanent and separable connexion have been developed and used on telecommunication equipment; some of these are discussed below, with typical arrangements described and illustrated under four general classifications.

Direct Permanent Connexions to the Printed-Board Conductors

The use of direct permanent connexions to the printed conductors is the simplest and cheapest, and, in some respects, the most reliable method; it has been employed extensively in various forms. It has, however, the major disadvantage that the making of permanent connexions to the board on initial assembly or on any subsequent removal for fault-location purposes involves the risk of damage to the board; a permanent method of connexion should not, therefore, be used if frequent removal is likely to be necessary. Furthermore, a generous spacing of the conductors on the board, in order to give the additional space necessary for making soldered connexions, militates against economical layouts. It is now usual to employ eyelets, posts or terminals let into the board rather than to make connexions directly to the copper laminate, but a considerable number of boards are in existence with connexions made directly to the copper.

If relatively large components are used on a board, hollow posts can be let into the laminate to facilitate the removal of faulty items, but usually the conductor leads of the normal type of component are passed through holes in the board and soldered by flow-soldering processes to the copper. The 700-type telephone³ supplied by some manufacturers uses a printed-circuit base, and the risk of damage when making external connexions to the instrument is avoided in this design by the fitting of specially designed clip-in terminals soldered to the board conductors. These terminals enable screw connexions to be made to the cord conductors; the arrangement is illustrated in Fig. 1.

†Mr. Hix is in the Engineering Branch, Home Counties Region, but was formerly in the Telephone Exchange Standards and Maintenance Branch, E.-in-C.'s Office.

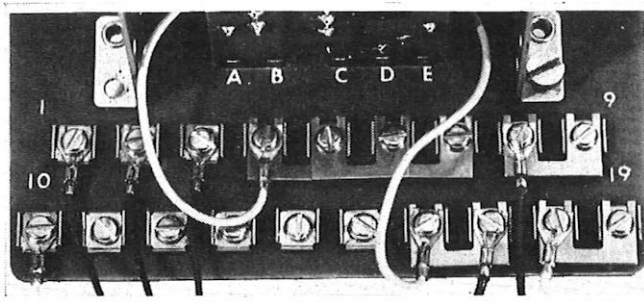

(a) Screw-Connexion Side

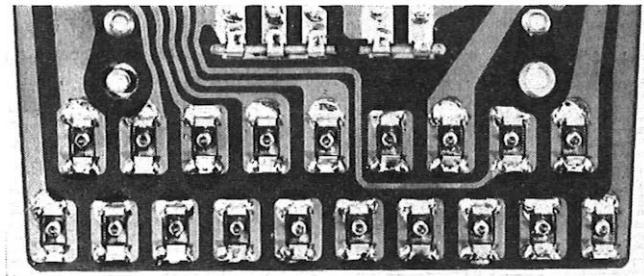

(b) Printed-Wiring Side

FIG. 1—CONNEXIONS TO PRINTED CIRCUIT OF 700-TYPE TELEPHONE

Separate Connectors

If separate connectors are used, one of the members of a multi-point plug-and-socket combination is attached to the edge of the printed board by pins, screws or rivets, and electrical cross-connexions are made in some instances by short insulated-wire straps to the printed-board conductors.

Manual soldering of the connexions to the board conductors or to posts and terminals fitted on the board is involved with this method, with the same disadvantages as with direct permanent connexions. Designs of edge connector have been produced that eliminate the need for a wire strap by enabling the connector terminals to be clamped or soldered to the board conductor, thus reducing the total number of soldered joints.

A wide range of electrical connectors is manufactured in this country; many of them are of proved reliability in other fields of use and can readily be adapted for use with printed boards. The use of separate connectors, therefore, enables one particular type of connector to be used with a wide variety of board types and sizes, thus facilitating the standardization of design and manufacture of the equipment. On the other hand, the provision of such connectors inevitably increases the space occupied by the board and involves soldering operations and additional connexion points.

It is a considerable advantage to be able to insert and remove the unit without risk to the connexions, but, if the individual contact forces are too large, as they may very well be if the connector has been designed for more robust equipment, there is a considerable danger of straining the board during such operations, with consequent risks of damage to the copper conductor pattern and the soldered joints thereon. In some applications the boards can be strengthened by metallic reinforcements along the edges, but these items add to

the construction cost and do not always ensure immunity from the troubles mentioned.

To reduce the contact forces required to the point at which the removal of a multi-point connector is easy, it is normally essential to employ noble-metal contacts on the connectors and, as a consequence, the connectors are necessarily expensive, adding materially to the overall cost of a unit. This has the result that such connectors are sometimes ruled out on economic grounds and ease of connexion is, inevitably, sacrificed.

Two types of plug and socket which have been designed for use on telecommunication equipment are illustrated in Fig. 2 and 3. The plug member of the

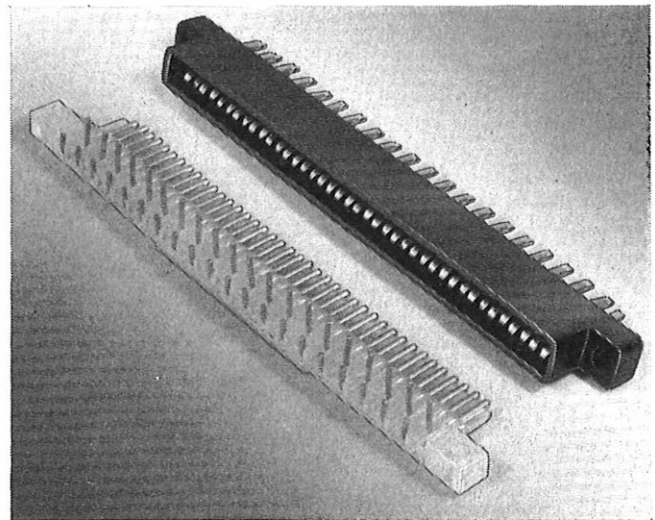

(a) Forty-way Plug and Socket

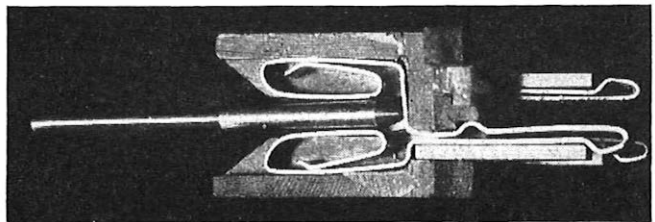

(b) Sectional View of One Contact of Connector Unit

FIG. 2—PLUG AND SOCKET DESIGNED FOR TELECOMMUNICATION EQUIPMENT

unit shown in Fig. 2 (a) employs individual gold-plated pins bent through a right angle for attachment to the

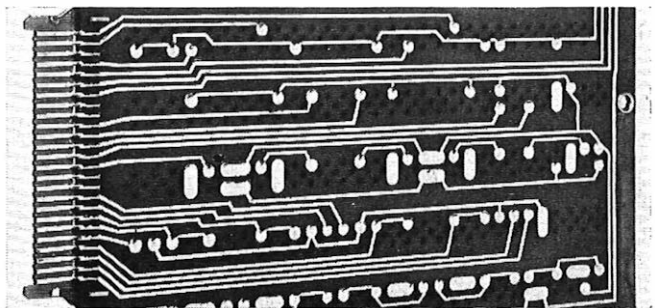

FIG. 3—MULTI-POINT CONNECTOR DESIGNED FOR TELECOMMUNICATION EQUIPMENT

printed-board conductors. These pins mate with the double cup-springs as shown in Fig. 2 (b).

Flat springs made from gold-plated silver wires which are wrapped around the high-grade insulation of the plug member are used on the item shown in Fig. 3. These plug units can be supplied in 11-contact, 25-contact and 33-contact units, and these sizes enable a variety of requirements to be met. The plug members engage with twin-spring jack units of a bimetallic construction using gold contact points.

Individual Contact Attachments to the Board

The edge of a printed board can be fitted with individual contact members of the plug or the socket type to enable separable connexions to be provided at less cost than with the previously described system of plugs and sockets. This has the advantage of cheapness and simplicity, and can obviate the need for a manual-assembly operation as some types of contact can be machine-inserted into the board. In its simplest form a flat prong with a right-angled projection for insertion into the board is used, but, with the object of simplifying the design of the member associated with the permanent wiring, designs have been produced in which a cup spring is attached to the board, whilst many forms of flat and dimpled spring contacts for attachment to boards have been produced.

In one design the prong-type contacts inserted into the board can be wire-wrapped by a binding process to the permanently-wired terminals, but normally the board-mounted contacts engage with specially designed socket connexions on the mounting. This system is satisfactory for boards on which the conductors can be adequately spaced and has advantages if a variable number of connexions are required, as the number of contact points in use can be kept to a minimum, with consequent economies. However, careful manufacture is essential as, with variations in tolerance and assembly, the insertion and withdrawal of the board can set up strains in the conductor patterns and, in the extreme, failures can result from misalignment of contacts. Examples of types of unit using board-mounted contacts are illustrated in Fig. 4.

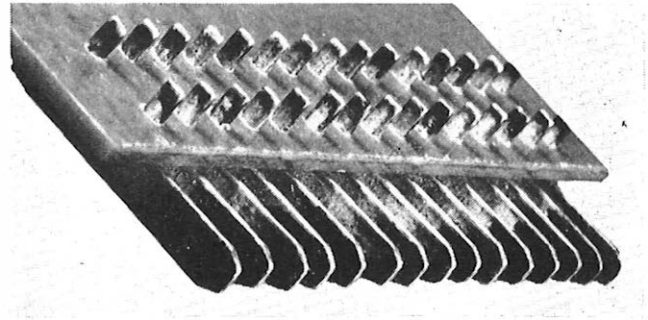

(b) Individual Plug "Prong" Contacts

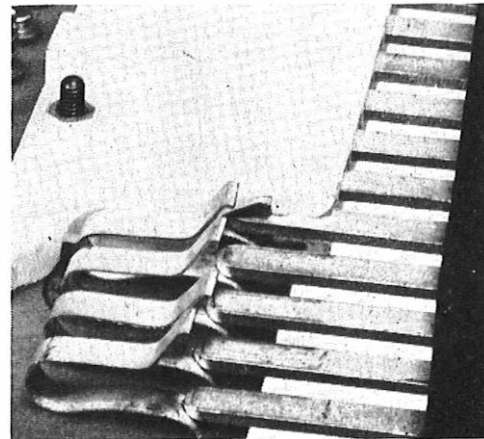

(c) Cut-way View showing Cup Springs in a Nylon Mounting Suitable for Fitting to a Printed Board

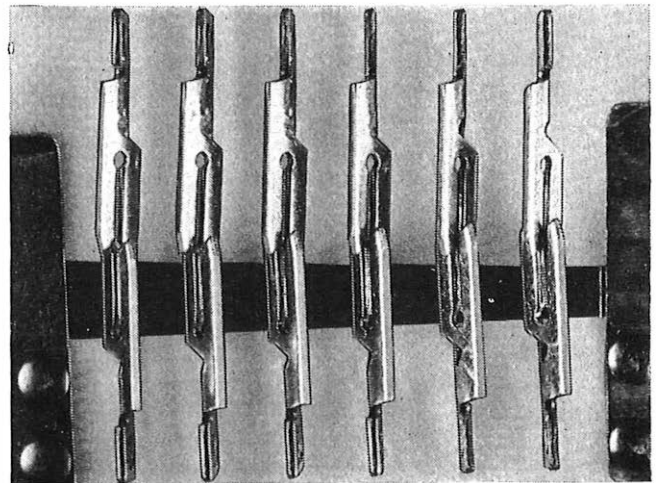

(d) Interlocking Claw Springs

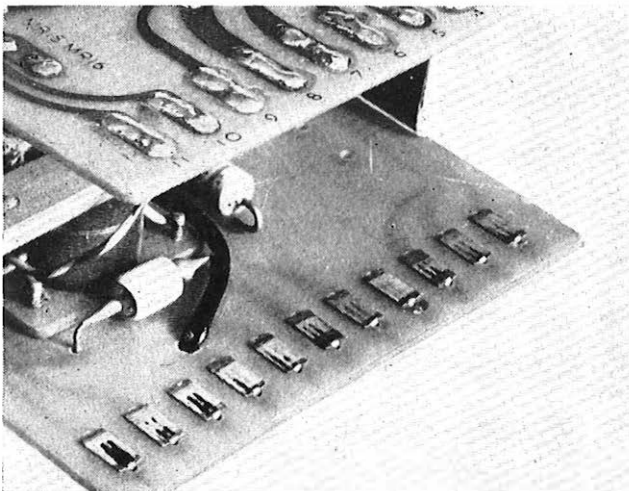

(a) Individual Plated-Contact Plates Fixed to Double Board by Solder

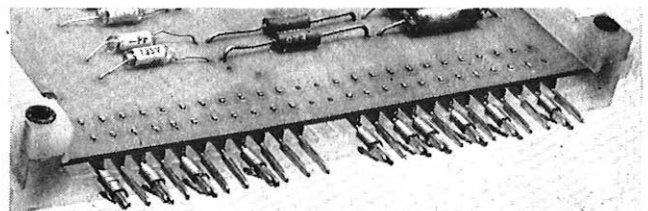

(e) Rectangular-Section Prongs on Printed Board and on Nylon Mounting Showing Wire-Wrapped Connexion of Working Contacts

FIG. 4—EXAMPLES OF BOARD-MOUNTED CONTACTS

Use of the Printed Board as a Plug

If the printed board is used as a plug, the conductor pattern on the board is arranged to produce a number of parallel contacts along one edge so that, in effect, a multi-point plug results. This system, which avoids the necessity for any physical connexions to the board, has the considerable advantage of simplicity, but various practical difficulties have prevented its general adoption. To ensure reliable connexions, the copper conductor ends need to be coated with a protective medium, usually either gold or palladium, and, in view of the cost of these materials, a selective system is usually employed to restrict the area coated.

Unless considerable care is taken in the choice and control of the plating process there is a risk of impairing the adhesion of the copper pattern to the board, with eventual peeling of the conductors. In these selective plating processes it is usual to arrange for a commoning strip joining the conductor ends to be included in the board design to facilitate electro-plating; this strip is cut away after plating. This cutting operation can result in the formation of sharp edges and expose an unsealed section of insulant to the possible ingress of moisture.

Frequent plugging action inevitably increases the risk of conductor peeling, and it is, therefore, desirable that removal and insertion of the board should be infrequently required in service and that a suitable low-pressure-contact jack should be associated. The use of such jacks can give satisfactory results, but, to avoid any possibility of damage to the board, designs of connector have been produced in which the contact pressure is applied after the positioning of the board, by the application of either a spring or screw. If it is preferred to use the insertion force to secure the engagement of the contacts it is necessary to pay careful attention to the design of the end of the board, and to provide lead-in and locating devices on the board and the socket to ensure correct alignment.

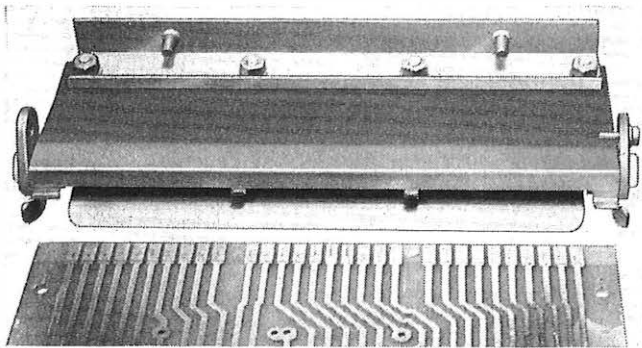

FIG. 5—PALLADIUM-PLATED CONTACT TERMINATIONS AND PRESSURE-PLATE TYPE OF JACK

Fig. 5 illustrates a typical plated board with its associated jack, which is designed for applying contact pressure after the board has been inserted in the jack. A mechanical or electromechanical method can be used for lowering the jack contacts into association with the printed board.

SOCKETS

The type of device fixed to the printed board determines the socket or jack design, and a variety of

arrangements have been used. The thinness of many boards in use ($\frac{1}{16}$ in. is a common thickness) and the close spacing of the board contacts are the principal difficulties which affect the design of sockets for the accommodation of plated boards. Some degree of float must be allowed for the positioning of the individual contacts, to cover manufacturing tolerances and the effects of warping of the board, otherwise the inevitable pressure variations resulting between individual contacts can cause the failure of connexions. One type of socket contact giving the requisite degree of float in a plane at right angles to the board is illustrated in Fig. 6.

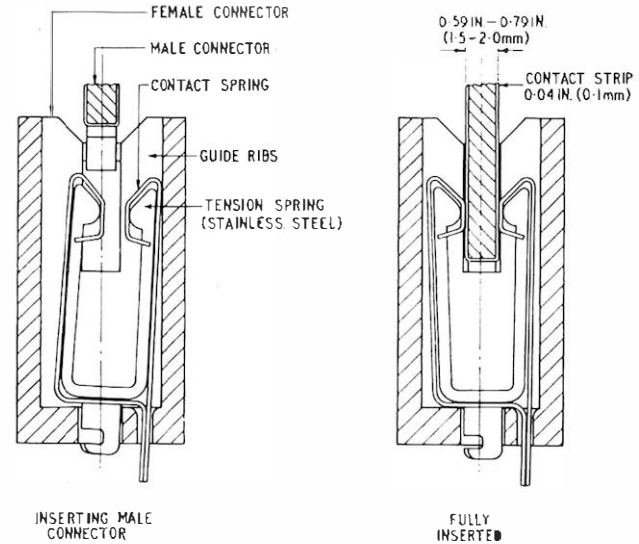

FIG. 6—SECTION OF SOCKET WITH FLOATING CONTACT

Locating devices are generally used to ensure the correct lengthwise positioning of the board, and it is a common practice to introduce polarizing devices into the socket to ensure that only the correct type of board for a particular circuit function is inserted into a particular socket. Fig. 7 illustrates a type of socket in which

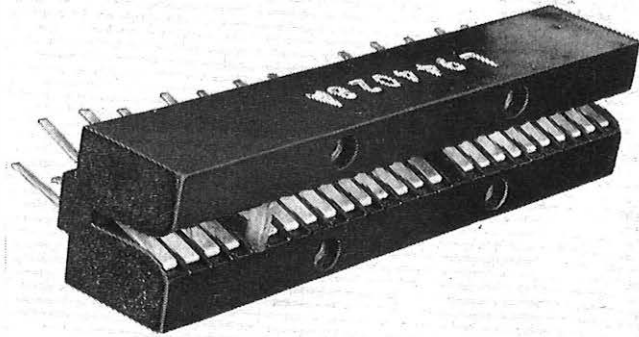

FIG. 7—SOCKET WITH NYLON POLARIZING DEVICE

individual contacts can be replaced by insulated barriers that must marry up with an appropriate slot on the card before the card can be inserted.

CONCLUSION

At the present time no single method of making connexions to printed-circuit boards has established its superiority over the remainder, and the choice is fre-

quently dependent upon the designer's outlook and the factory facilities available. There is a tendency to use plugs and sockets for high-grade work, and the British Standards Institution is at present considering the adoption of national standards. In the interim the Post Office Engineering Department has issued a general specification for connectors used with printed wiring, and has been engaged in testing proprietary items submitted by manufacturers, with the result that a number of designs have now been type-approved for use on Post Office equipment. The ultimate choice for a particular equipment depends upon an assessment of the cost and of the reliability requirements, but there will undoubtedly be a tendency towards the increasing use of methods that reduce the hand-assembly operations to a minimum. The need for cheaper but completely reliable systems of connexion will continue to spur development efforts.

ACKNOWLEDGEMENTS

The permission of Standard Telephones & Cables, Ltd., to reproduce Fig. 3, 5 and 6, of the General Electric Co., Ltd., to reproduce Fig. 2, 4 (a), 4 (c) and 4 (e), and of the Automatic Telephone & Electric Co., Ltd., to reproduce Fig. 7 is acknowledged.

References

- ¹WILLMOTT, J. W. An Introduction to Printed Circuits and their Application to Telecommunications. *P.O.E.E.J.*, Vol. 52, p. 170, Oct. 1959.
- ²FAIRWEATHER, A., and FROST, E. J. The Design and Testing of Semi-Permanent Metallic Contacts for Use at Low Voltages. *P.O.E.E.J.*, Vol. 53, p. 26, Apr. 1960.
- ³SPENCER, H. J. C., and WILSON, F. A. The New 700-Type Table Telephone—Telephone No. 706. *P.O.E.E.J.*, Vol. 52, p. 1, Apr. 1959.

Book Reviews

"Principles of the Statistical Theory for Communication."
W. W. Harman. McGraw-Hill Publishing Company, Ltd. xi + 291 pp. 161 ill. 81s. 6d.

This book is as intelligible, helpful and practical as a text covering modern communication theory could be. It is for engineering or, perhaps, physics graduates who have mathematical interests rather than formal mathematical attainments—indeed some knowledge of probability theory and statistics and an understanding of a Fourier spectrum are probably sufficient to get started. The author shows sound judgment throughout of the rate at which new concepts can be introduced.

The book is deeply, and successfully, concerned to treat the measurement and handling of "information" in a way that will be of value to telecommunications engineers. Its approach springs from "signals" themselves rather than abstract conceptions of "information"; for example, nearly 100 pages have passed before there is need to bring in the idea of a "bit" as a measure of information. The first third of the book deals with the representation of signals by time functions, power spectra, correlation functions, etc., and with their generation by random processes, specified essentially in probability terms. The middle part of the book deals with what is usually regarded as communication theory proper: it confines itself to the three essential topics of measuring information, applying the resulting ideas to the "channel capacity" of a discrete channel (e.g. a binary digital channel) and, finally, considering the more difficult case of the "continuous" channel with its dependence on bandwidth and noise. There is a particularly good discussion of how a communication link performs as its channel capacity is approached. The remainder of the book, mostly rather more difficult, covers a number of miscellaneous topics, one of which is the representation of continuous-spectrum noise.

Although the book deals with mathematical concepts, and is nowhere elementary, it keeps as near to practical communication problems as possible and is free of arid discussion and pedantry. There are many well-drawn diagrams, well related to the text, which is clear, vivid and informal in style. The book covers much useful ground in less than 300 pages and is to be recommended.

J.S.

"Microwave Engineering." A. F. Harvey, D.Phil., B.Sc. (Eng.), M.I.E.E. Academic Press, Inc. (London), Ltd. xlii + 1,313 pp. 518 ill. 250s.

The author attempts to survey, in the 1,313 pages of this book, the whole field of microwave engineering. Waves in periodically-loaded waveguides, the generation of "ultra-microwave" frequencies, aeronautical navigation and the properties of biological materials being but a few of the diverse subjects considered. The result is that the majority of the subjects are dealt with rather briefly, the author expecting the reader to make good use of the references, which average about 400 per chapter. If each chapter had been written by a specialist, as is usual in a book covering such a wide field, fewer references would have been required and they would have been more selective.

Waveguide transmission is treated thoroughly. Not only are the electrical properties of all types of waveguide, including ridged guides and striplines, dealt with but also such topics as waveguide flanges, the alignment of guides and the distortion of guides due to pressurizing. The chapter on aerials, a very important subject, could have contained much more information. The chapter on radio-relay systems is too concise and space could perhaps have been devoted to the frequency deviations used in f.d.m./f.m. multichannel telephony systems, branching methods, the calculation of baseband signal-to-noise ratios and testing techniques. Nearly as much space is allotted to circular-electric mode transmission, which has yet to be proved practicable for working systems, as to radio-relay systems, including space communications. A chapter is devoted to low-noise amplification, important in space communications and radio astronomy. Descriptions of measuring techniques, appropriate to the subjects discussed, are given throughout the book. The practical side of microwave work has not been overlooked; subjects dealt with include the fabrication and finish of components and the measurement of their surface texture.

The practising microwave engineer should find the book extremely useful but it is essential that the papers referred to should be readily available. The student will find it advantageous to have access to the book but, owing to lack of detailed explanation, it is doubtful if the book justifies a permanent place on his bookshelf.

C.F.D.

The Post Office Type 12 Relay

B. H. E. ROGERS and A. KNAGGS†

U.D.C. 621.318:621.395.34

A cheap and simple relay has been developed for use in the line circuits of low-calling-rate subscribers at exchanges where the 50-point linefinder scheme is used for such subscribers. The new relay is not as versatile as the 600-type relay, but is reliable and has an adequate life.

INTRODUCTION

It is the practice at director and non-director telephone exchanges to provide each subscriber with a pair of controlling relays, generally designated line (LR) and cut-off (K) relays. These relays are usually of the 600-type,¹ located together on strip-mounted relay plates adjacent to the uniselector shelves.

In the 50-point linefinder system for low-calling-rate subscribers² the circuit conditions for LR and K relays are less onerous than where each subscriber's line is equipped with a uniselector. For this reason a simpler and cheaper relay than the 600-type can be used, and the item introduced for this purpose is known as the Type 12 relay. Although developed specially for this system, the Type 12 relay may also be used in circuits requiring in quantity a simple and reliable, though not versatile, relay.

The new design comprises a unit of multiple construction in which up to five individual comb-operated relays

are assembled on a common yoke that is mounted directly on the linefinder rack, alternate units with appropriate spring-sets and coils being used for the LR and K relays, respectively. The manufacturing and assembly methods adopted have resulted in a relay less costly than the 600-type, but with a satisfactory performance and a life more than adequate for low-calling-rate-subscriber usage.

ASSEMBLY AND MOUNTING

A unit of Type 12 relays, with one relay removed, is shown in Fig. 1, and Fig. 2 illustrates the four replaceable component parts of an individual relay, i.e. the armature, coil, spring-set assembly and spring-set-bracket front clip. These four parts are assembled on one of the five core-extensions of the common yoke or frame where they are self-locating and interlock, needing,

†Telephone Exchange Standards and Maintenance Branch, E.-in-C.'s Office.

¹CLACK, C. W. The Post Office 600 Type Relay. *P.O.E.E.J.*, Vol. 28, p. 293, Jan. 1936.

²FOX, W. H., ASHWELL, J. L. K., and WEAVER, A. L. Subscribers' 50-Point Linefinder System. *P.O.E.E.J.*, Vol. 51, p. 81, July 1958.

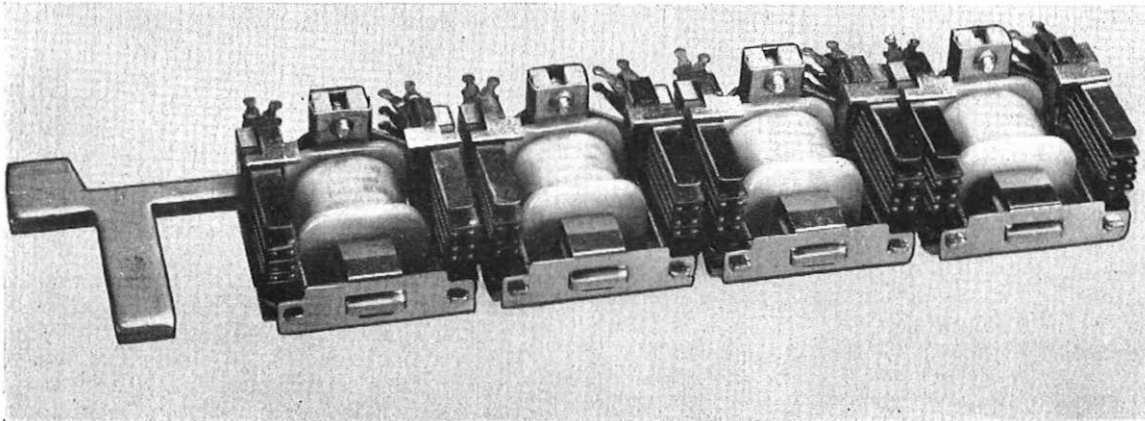

FIG. 1—UNIT OF TYPE 12 RELAYS

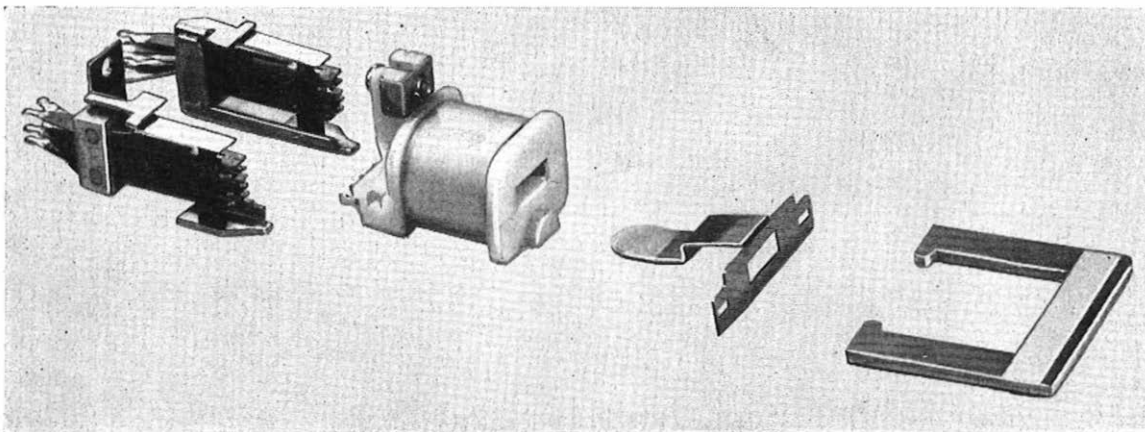

FIG. 2—COMPONENT PARTS OF TYPE 12 RELAY

finally, only a single screw and spring nut to secure them. This method of assembly compares to advantage with that for the 600-type relay, each of which requires 11 screws and one nut.

The armature side of the frame presents a flat surface as the datum face to which all critical dimensions are related. The manufacturing tolerances, particularly on moulded piece-parts, are such that an assembled relay requires little, if any, adjustment to give its required performance.

Fig. 3 shows Type 12 relays mounted vertically on a linefinder rack.

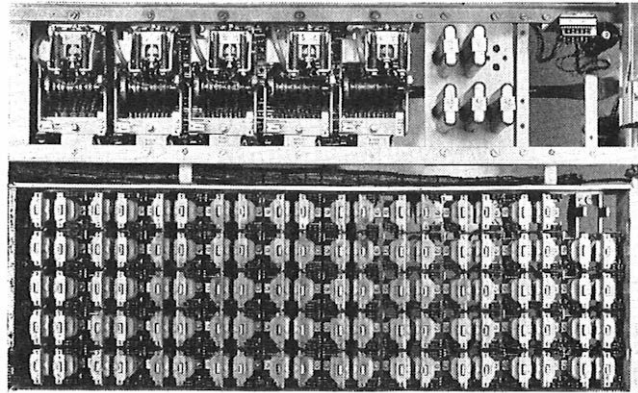

FIG. 3—TYPE 12 RELAYS MOUNTED ON A LINEFINDER RACK

In this article the disposition of parts of the relay in terms of left-hand side, right-hand side, etc., is given with respect to a relay held so that the spring-sets are uppermost and the spring-set contacts are nearest the viewer.

SPRING-SETS

Adjustment

The initial specification for the Type 12 relay called for contact pressures[‡] of 20-40 grammes. It was expected that this range would allow machine pre-tensioning to be used, with the aim of eliminating adjustment after assembly. On 600-type relays block pressures are nominally 15-21 grammes, a range too narrow for satisfactory

[‡]Contact pressure—the term is used here in its commonly used sense, i.e. to indicate the total force on the contact, not the force upon a unit area.

application of machine pre-tensioning techniques.

Type 12 relays are now in quantity production, and pre-tensioned springs are giving contact pressures around 30 grammes without other than occasional adjustment for twinning of the contacts, and even this is expected to become unnecessary as tooling methods are improved.

Assembly

The left-hand and right-hand spring-sets are each mounted on a single bracket as shown in Fig. 2, the maximum number of springs in a spring-set pile being six.

In a 6-spring pile on a 600-type relay, the cumulative effect of separator-thickness and spring-thickness tolerances can introduce a fanning effect at the contact end, and this may result in difficulty in obtaining correct clearances and block lift without recourse to excessive bending of spring tips.

In the Type 12 relay, the springs are clamped by means of two moulded separators or combs (Fig. 4). These interlock to form a separator block with seven slots into which fit the contact springs and return spring. The separator block with its springs is then secured to the spring-set bracket by a retaining clip and plate. With this design, the position of each spring relative to the datum face is independently fixed and is unaffected by the number of springs in the pile.

The slots in the separator block are designed to take the 16-mils-thick stationary springs, and for satisfactory clamping of the spring-set all slots must be filled. The moving springs, which are only 10 mils thick, are padded from the clamping point rear-wards by 6-mil spacers shaped as tags (Fig. 4); these have the additional advantage of strengthening the wiring tags of the 10-mil springs. Those separator slots not occupied by springs are filled with 16-mil tags that may be used as extra wiring points. Alternate wiring tags are staggered to facilitate wiring.

Spring Positioning and Movement

Spring positioning and movement are effected by two combs of self-lubricating plastic material placed back-to-back. The rear, or stationary comb, which has a V-slot on one side (Fig. 4) maintains the stationary springs in their correct positions. The front, or lifting comb, which slides in the V-slot in the stationary comb, transmits the armature movement to the moving springs.

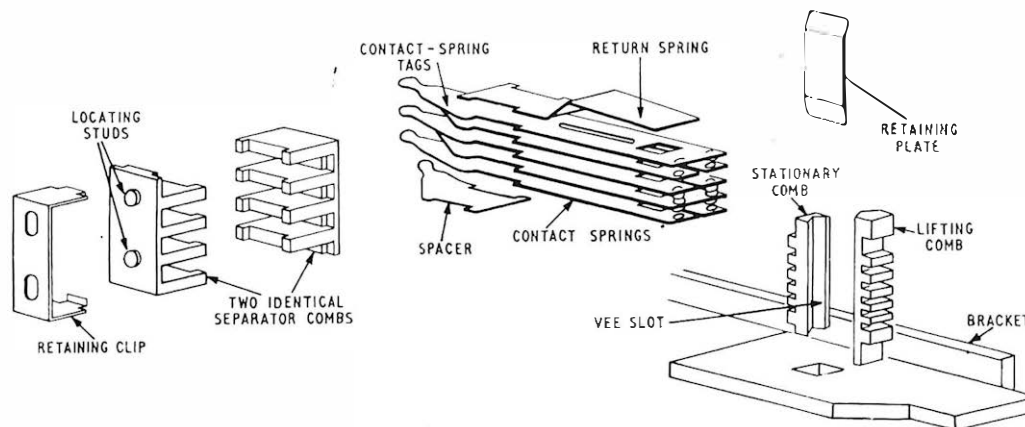

FIG. 4—DETAILS OF SPRING-SET ASSEMBLY

Both combs are located at their lower ends in a hole in the spring-set-bracket arm and are held in position by the contact springs through which they pass. Each contact spring is stiffened by a longitudinal indent (see Fig. 5)



FIG. 5—CONTACT SPRING

extending from the rear of the spring to a point just backward of the stationary comb. The springs thus maintain their straightness after tension has been preset in manufacture, with the result that clearances, spring-set travel and contact twinning are easier to obtain.

Contact bounce is very largely eliminated in this design by the use of "reverse" action in which the centre spring of a change-over action is the buffer or stationary spring and the outer springs, which are tensioned towards the stationary spring, are the movers actuated by the lifting comb. Fig. 6 is a typical oscillograph, showing 0.2 ms

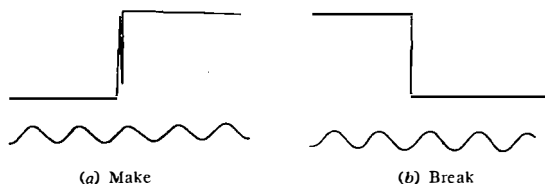

FIG. 6—OSCILLOGRAPH SHOWING EFFECT OF CONTACT BOUNCE

contact bounce. The longest period of bounce so far recorded is 0.3 ms.

Restoration of the lifting comb on release of the armature is ensured by a return spring located above the contact springs. A return spring is required with this type of action since springs of make-contact units are tensioned upwards and it is necessary to ensure comb clearance at all springs of break-contact units on completion of release of the armature.

With the relay in the released position (see Fig. 7) the

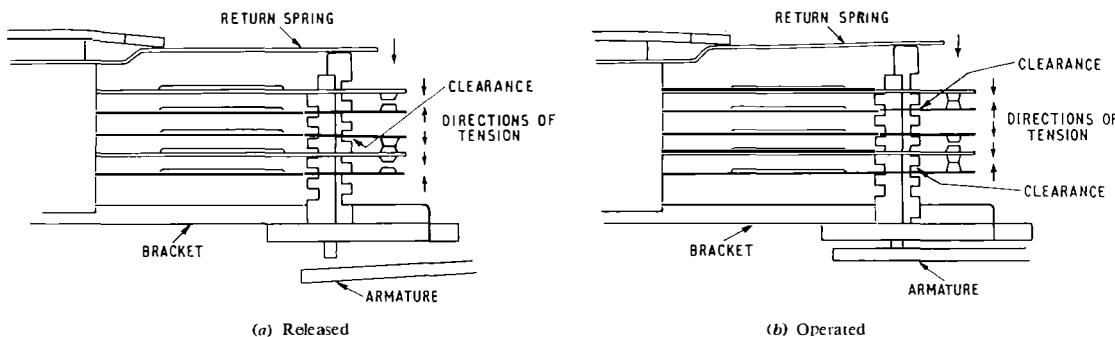

FIG. 7—SPRING-SET OPERATION

spring of a change-over-contact unit nearest the armature is held away from the stationary spring by the tension of the return spring on the lifting comb. The spring furthest from the armature is in contact with the stationary spring, and there is a clearance between the step of the lifting comb and the moving spring to ensure

adequate contact force for the break-contact unit. When the relay is operated, this step of the lifting comb is raised and disengages the moving spring of a break-contact unit. The moving spring of the make-contact unit is then allowed to rise and makes contact with the stationary spring. Further movement of the armature provides a clearance between the make-contact unit moving spring and its corresponding comb step to ensure adequate contact force for the make-contact unit. Satisfactory contact openings and comb clearances are ensured by the consistency of the comb-step dimensions in production.

Contact Combinations

The maximum of six contact springs that can be fitted on either spring pile provides for up to six make-contact units, six break-contact units or four change-over-contact units, or combinations thereof. If six contact springs or less are required, as, for example, in the LR relay with two make-contact units, they are fitted on the left-hand side only. With the type of construction used, unequal loading on the armature does not cause rocking to the same extent as with a similar arrangement on 600-type relays, and the use of a single spring-set contributes to the savings in cost and increases the relay sensitivity, since only one return spring is needed. Make-before-break contact units are not required in the linefinder circuit and so have not been included in the currently available spring-set actions. However, provision has been made for these contacts to be introduced at a later date if necessary.

Silver contacts are used for the 50-point linefinder LR and K relays.

Spring Numbering

Since the positions of the break and make elements of a change-over-contact unit are the reverse of those in the 600-type relay, the contact springs of Type 12 relays are numbered from the top downwards towards the armature. The symbols used on Post Office diagrams to denote make, break and change-over spring-set actions are not strictly applicable to reverse-action spring-sets because the moving springs of the latter-type spring-set

are represented by the symbols as the buffer springs and the stationary springs as the lever springs. However, with make-contact units and break-contact units no difficulty should be experienced because there are only two connexions. In the case of change-over-contact units the numbering of springs towards the armature should pre-

vent confusion, since, as with existing practice, the break spring of each unit will bear the lowest number and the make spring the highest.

In order to locate the combs at both ends and restrict their lateral movement to a minimum, a single-action spring-set has the contact unit fitted in the top position remote from the armature and additional units are then positioned successively towards the armature. This arrangement conforms with the normal spring numbering.

The spacing of the contact springs is such that, irrespective of the contact-action combination in the spring pile, only one version of each comb is required.

COIL ASSEMBLY AND ARMATURE

The plastic coil-former is usually moulded in two parts, the joined faces being in the same plane as the datum face of the relay. As the material used has the high-insulation properties necessary for adequate winding-to-frame insulation, the windings can be wound directly on the former, and the use of additional insulation is only to hold the two halves of the coil former together in preparation for winding. The windings are directly terminated without lead-in or lead-out tails.

On 600-type relays the direction of winding and the disposition of coil tags result in a cross-over of the lead-out wires at their termination. As high back e.m.f. surges may arise during relay release, breakdown of insulation at the cross-over point is a possibility. This weakness can be avoided either by reversing the direction of winding, which is not practicable for manufacturing reasons, or by reversing the terminating points as has been done on the Type 12 relay.

Due to the smaller size of the coil-former, a fully-wound coil contains only about one half of the copper of a fully-wound 600-type coil. This represents a considerable contribution to the saving in cost achieved for the relay as a whole.

The armature is a simple U-shaped stamping in electrical-quality mild steel. At the hinge-end the armature is lightly held close to the yoke by location in recesses in the rear of the coil-former. The front of the coil-former incorporates an armature back-stop in the form of a projection that limits the movement of the armature away from the yoke. With the armature resting against its back-stop there is a minimum clearance of approximately 3 mils between the armature and the lifting combs, ensuring full restoration of the combs on release.

Three layers of 2.5-mil polyester tape are always stuck to the armature. By having one, two or three layers on the spring-set side of the armature, residual gaps of 2.5, 5 or 7.5 mils are obtained. If three layers are not required for the residual gap, the remainder are stuck to the opposite side of the armature. This arrangement allows for one of three fixed values of residual to be used whilst maintaining a constant travel without adjustment of piece-parts.

After attachment to the armature, the tape adhesive is cured at 120°C for 4 hours. This curing, which is irreversible, ensures that no tacky adhesive is allowed to remain on the relay parts after manufacture. The curing temperature is governed by the softening point of the tape. A period of 4 hours does not interfere with production, since large quantities of armatures are cured at the same time.

APPLICATION IN THE 50-POINT LINEFINDER SYSTEM

The circuit operation of the 50-point linefinder has been described in the article mentioned earlier. Type 12 relays were developed to replace the 600-type relays in the line circuit and the circuit operation remains as previously described.

A non-inductive resistance is required across both LR and K relays (Fig. 8). On the K relay this takes the

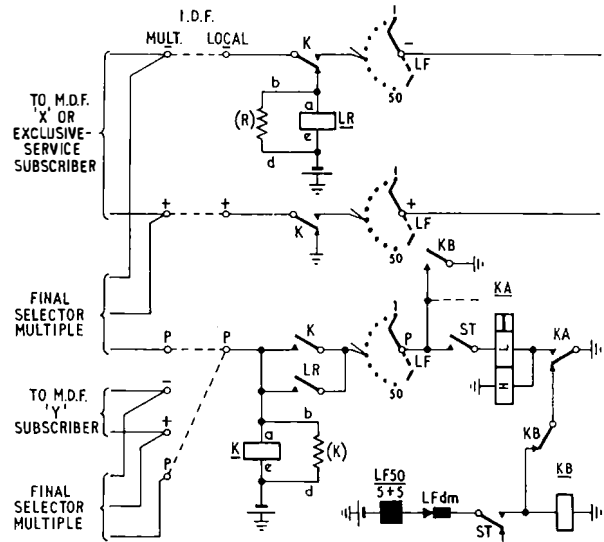

FIG. 8—SUBSCRIBER'S LINE CIRCUIT IN 50-POINT LINEFINDER SYSTEM

form of a non-inductive winding on the coil, brought out to separate tags. This winding provides a non-inductive path for the KA relay in the linefinder when switching to the marked outlet. The two windings are strapped externally. For the LR relay, sufficient lag has to be provided to cover the transit time of the K-relay contacts between disconnection of relay LR and the application of the holding circuit for relay K. In this instance the wattage to be dissipated is less, and an external carbon resistor is fitted.

The contact opening and pressures used have resulted in a satisfactory performance for at least 100,000 operations, which represents a 30-year life at an annual calling rate of more than 3,000 for LR relays and an incoming and outgoing annual calling rate greater than 1,500 for K relays. However, with the type of construction and materials used, a life of several million operations is likely, with contact wear as the limiting factor.

MAINTENANCE

The use of comb-operated spring-sets and relatively-high contact pressures should reduce maintenance to a minimum. Adjustment of the return-spring tension will compensate for any small loss of tension in the moving springs due to aging, while twinning of the contacts may be carried out to compensate for contact wear and loss of comb lift.

A coil or armature can be replaced without any readjustment being needed. If a spring-set is changed, the only adjustment likely to be necessary is a small change in the tension of the return spring to give the required performance.

Since up to five relays can be mounted on the common yoke, an individual unmounted relay is stocked as a "kit of parts" comprising the four interchangeable parts—coil assembly, armature, spring-set assembly and front clip. The relay code refers to these four parts only, the common yoke being a separate item which is ordered as required: e.g. if 17 relays are to be used in a particular equipment, they would be ordered as 17 kits of parts and four common yokes, leaving three spare relay positions.

CONCLUSION

The Type 12 relay was developed specifically to provide line and cut-off relays meeting the circuit

requirements of the 50-point linefinder system at minimum cost. This objective has been attained by adopting a simple design with closely-toleranced parts and assembly features which reduce adjustment time to a minimum.

Although the relay has not the versatility of the 600-type, other applications are expected to arise for which the characteristics of the Type 12 relay will prove acceptable.

ACKNOWLEDGEMENTS

The Type 12 relay was developed by Ericsson Telephones, Ltd., on behalf of the British Telephone Technical Development Committee.

Book Reviews

"Differential Amplifiers: Their Analysis and Their Applications in Transistor D.C. Amplifiers." R. D. Middlebrook, M.A., M.S., Ph.D. John Wiley and Sons. xii + 115 pp. 21 ill. 60s.

The need for differential amplifiers occurs when the potential difference between two points, neither of which are at earth potential, has to be amplified. A considerable potential between these points and earth may exist, and an essential feature of a differential amplifier is that it faithfully amplifies the difference potential while remaining unaffected by the above-earth potentials. These amplifiers are frequently used in biological and scientific instrument work.

The book reviews the requirements of such amplifiers; these are usually achieved by a symmetrical pair of unbalanced circuits to which feedback is applied decreasing the gain only to the above-earth potential. The analysis of such a pair is simple when they are perfectly symmetrical but, since this never occurs in practice, a method of determining the effect of lack of symmetry is necessary. A technique for such an analysis is developed which leads to improved designs.

The examples discussed in the book are d.c. differential amplifiers using transistors but the technique is of general application. Those who are familiar with normal amplifier design will find the text easy to follow, and the book provides an excellent grounding in the analysis of differential amplifiers. The designer will need additional information concerning the more practical aspects of design.

W.T.D.

Proceedings of the International Conference on the Ionosphere, 1962. Institute of Physics and the Physical Society. ix + 528 pp. 269 ill. 65s.

This is an excellently produced volume in which are collected papers by scientists of several nationalities on the subject of the ionosphere. The papers were those presented at a conference held in 1962 at Imperial College, London, and their content well illustrates the extension in knowledge which has taken place since the earlier conference on the same subject held in Cambridge in 1954.

The problem of organizing the material presented at such conferences so as to give a comprehensive and reasonably-balanced picture of present-day information are well known. The conference covered by this volume met some of these difficulties by a division of the subject matter into four main parts, viz: Ionosphere Construction and Ionizing Radiation, Geomagnetism and the Ionosphere, Irregularities and Drifts in the Ionosphere (of particular interest to the radio engineer), and Mathematics of Wave Propagation through the Ionosphere. Each sec-

tion is preceded by a valuable summary of known information in the field and followed by a brief survey of the papers presented. A final short section deals with preliminary results from the first Anglo-American satellite, Ariel.

While the contents of this volume are valuable and well-presented, their value lies very largely in the scientific realm. Nevertheless, the engineer planning radiocommunication at frequencies below 100 Mc/s will gain background information of value by reference to some of the papers, information that should at least prevent him from taking too simple a view of the ionosphere as a propagating medium.

J.K.S.J.

"Variable Resistors." Vol. 2, Radio and Electronic Components. G. W. A. Dummer, M.B.E., M.I.E.E. Sir Isaac Pitman & Sons, Ltd. xi + 228 pp. 147 ill. 45s.

Most serious users of electronic components are familiar with the fairly comprehensive treatment adopted in this series, and will probably be mainly interested in how the 228 pages of the present edition differ from the 176 of the first.

Part of Chapter I ("General Information on Components") dealing with Government specifications has been augmented.

Chapter II ("General Information on Variable Resistors and Potentiometers") contains augmented tables of resistivity, and a section on the choice of a variable resistor has been added.

In Chapter III ("Measurements on Variable Resistors") a short addition has been made on the use of a transformer bridge for resistance measurement.

In Chapter IV ("Wire Characteristics: Contacts, Wear and Noise") the section on noise has been expanded.

Chapter V ("Curve Matching and Non-Linear Functions Obtainable with Linear Variable Resistors") has new sections on non-linear functions obtained by cascading potentiometers, and functional laws for the Helipot range, as well as an augmented section on padding variable resistors.

In Chapter VI ("General Purpose Types of Variable Resistor") the section on carbon composition coated track types is augmented considerably.

Chapter VII ("Precision Variable Resistors") has a new section on the selection and inspection of precision wirewound potentiometers.

In Chapter VIII ("Special Types of Variable Resistor and Potentiometer") small additions cover applications of sine-cosine card potentiometers and photo resistors.

Chapter IX ("Miscellaneous and Experimental Types of Variable Resistor") has a new section on the oxide-film potentiometer.

The book gives a thorough account of most aspects of variable resistors.

A.A.N.

An Automatic Screw-Sorting Machine

G. HALEY, B.Sc.(Eng.), A.M.I.E.E., and T. F. A. URBEN, B.Sc.(Eng.), A.M.I.E.E.†

U.D.C. 681.18:621.822.2

An automatic machine has been developed for sorting screws recovered from dismantled telephone instruments to obtain seven specific sizes of screw required for use in rebuilding the telephone instruments. The principle of operation and the construction of the machine are described. The quantity of screws sorted is over 8 tons per year.

INTRODUCTION

THE Factories Department of the Post Office is responsible for the repair and renovation of recovered telecommunications equipment for which such processes are economically worthwhile. The work is done in factories in London, Birmingham and Edinburgh, and at Cwmcarn in Monmouthshire. The Cwmcarn factory deals exclusively with telephone instruments and bell-sets, and flowline methods are used both for dismantling the various complete telephones on receipt and for re-assembly of the component parts after refurbishing.

It has not proved practicable to separate, during the dismantling process, all the various sizes of instrument screws that are removed, and this raised the problem of developing an economical process to sort approximately 100 lb per day of mixed types of 4 BA and 5 BA screws.

After some study of this particular problem the automatic sorting machine* which is the subject of this article was developed. It is formed of two separate sorting units each with its own driving mechanism (Fig. 1). In the first sorting unit, consisting of a filling hopper and linear feeder, B, unwanted screws, washers and other trash are separated from the wanted screws which are fed into the bowl of the second unit, A. In this unit the wanted screws are sorted by stages, each variety being discharged into a separate tray as shown at C. Any of these trays, when full, can be removed and replaced by an empty one without stopping the sorting process.

This machine is now installed and has proved able to sort up to 30 lb/hour of mixed screws into seven desired sizes.

machine. The required screws are 4 BA and 5 BA cheese-headed plated-brass screws of $\frac{3}{16}$ in. and $\frac{1}{4}$ in. lengths and having various head diameters.

Before being sorted, all the recovered screws are re-nickel-plated by a barrel plating process, but other material is included with the wanted screws and this can only be considered as trash. Fig. 3 shows the range of items liable to be fed into the machine. Fortunately, the quantity of trash is not excessive, being only about 5 per cent by weight of the mixture, but it

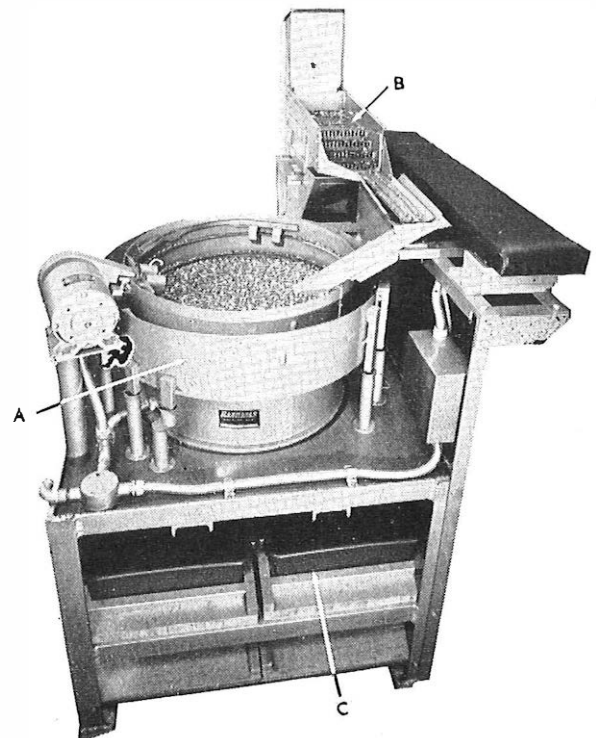

A—Second sorting unit
B—Filling hopper and linear feeder
C—Tray for sorted screws
FIG. 1—SCREW-SORTING MACHINE

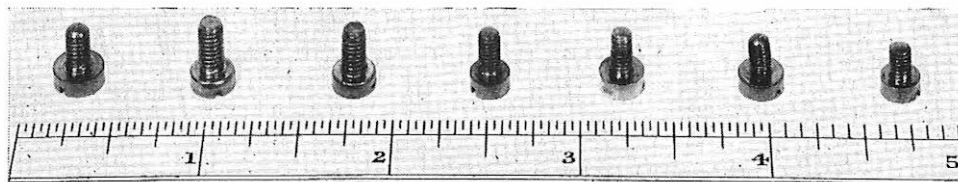

FIG. 2—RANGE OF 4BA AND 5BA SCREWS REQUIRED TO BE SELECTED

SORTING PROCESS

From the screws liable to be fed into it, only the limited range shown in Fig. 2 has to be selected by the

†Mr. Haley was formerly in the Post Office Factories Department but is now at the Post Office Research Station. Mr. Urben was also in the Post Office Factories Department but is now in the Telephone Exchange Standards and Maintenance Branch, E.-in-C.'s Office.

*HALEY, G., and WILSON, L. P. A Screw-Sorting Machine. *Machinery*, Vol. 99, p. 1,245, 29 Nov. 1961.

must be eliminated before the main sorting process can take place.

The complete sorting procedure is shown diagrammatically in Fig. 4. The initial stage consists of removing the trash by both sieving and visual examination; this serves to avoid any stoppages at the subsequent stages of sorting in the bowl, due to oddly-shaped items jamming the gauges. All screws have to be sorted for length and, as this particular operation is a very rapid

one, it was made the first sorting process, followed by sorting for head sizes. By exploiting the association of

set up. However, due to the angle and disposition of the springs, the vibration is at an angle to the vertical

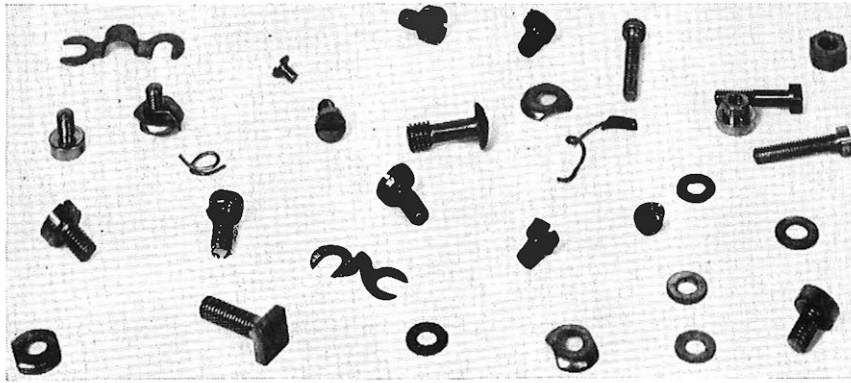

FIG. 3—TYPICAL RANGE OF PARTS LIKELY TO BE FED INTO MACHINE

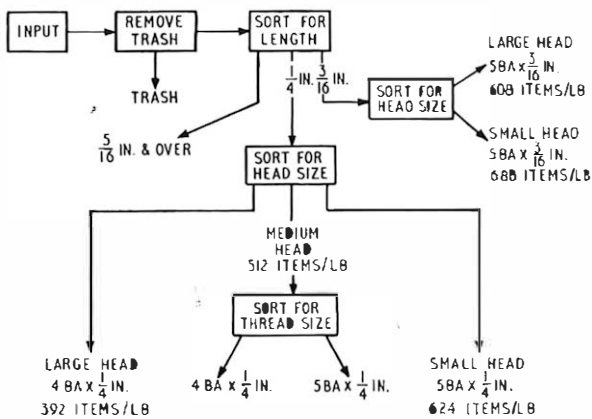

FIG. 4—SCHEMATIC DIAGRAM OF SORTING OPERATION

head size and length of screw, in only one case has it been necessary to sort for thread sizes to distinguish between 4 BA and 5 BA screws.

It was found possible to arrange all the screw-sorting operations with one 24 in. diameter bowl feeder and to use the simple linear feeder as an input store and trash-removal device (see Fig. 1).

FEEDER DRIVING MECHANISMS

The screws are caused to move by the vibration imparted to the feeders by electromagnetic drive units. The linear feeder consists of a heavy base, supported on flexible mountings, to which is attached an alternating-current electromagnet arranged in a vertical position with the poles upwards. To this heavy base a rigid platform is attached by means of cantilever springs set at an angle to the vertical, so that the upper ends of the springs, relative to their lower ends, are in the direction opposite to the desired direction of screw movement (Fig. 5). A laminated armature is attached to the underside of the platform directly over the magnet—as indicated in Fig. 5(a).

The magnet is energized from a 50 c/s mains supply, giving rise to a pulsing field; each energization attracts the armature and with it the platform, which moves against the resistance of the springs (Fig. 5(b)). Each time the magnetic field decays, the springs lift the platform from the magnet, and a regular vibration is thus

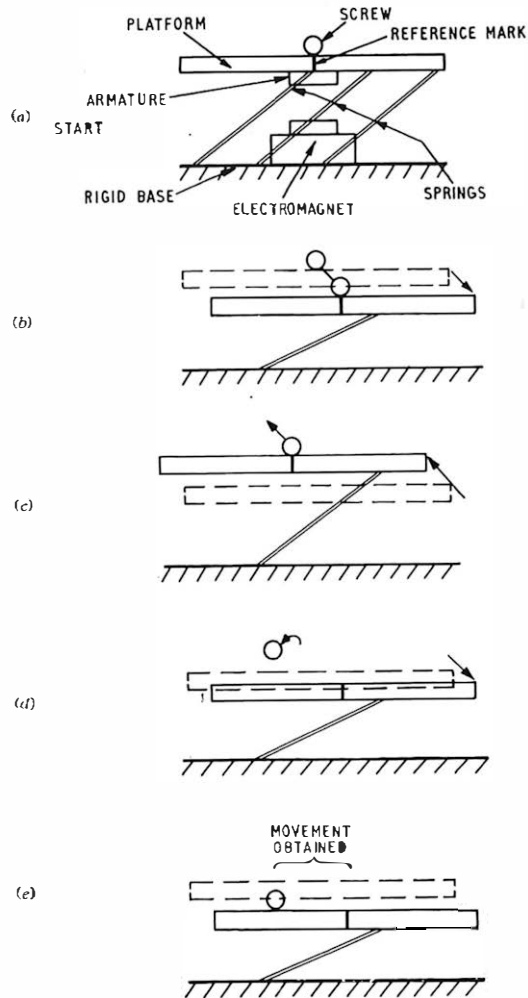

FIG. 5—OPERATION OF LINEAR FEEDER

so that parts on the platform move upwards and along when the platform is moving upwards (Fig. 5(c)), and when the platform goes downwards it retracts from underneath the parts and also moves in the opposite direction (Fig. 5(d)). Each time that the reversal of movement of the platform from upwards to downwards takes place, there is relative motion between the

platform and parts carried on it (Fig. 5(e)). This movement can be either horizontal or, if desired, up a slight incline, and material can thus be made to progress along the platform or up special sorting guides or flight bars.

The bowl feeder operates on a similar principle, a circular platform being mounted on cantilever springs arranged on a pitch circle concentric with the platform and the magnet. In this instance the vibration is not linear but rotary, or, to be precise, helical: it can be likened to a nut oscillating on a screw thread. Thus, parts in the bowl are caused to progress round it; also when the platform is retracted, since they continue in a straight line tangential to the bowl, the parts tend to flow towards the circumference. By securing helical ramps or flights to the periphery of the bowl, the upward component of the bowl movement can be exploited to cause articles in the bowl to travel up the flights, an angle of about 2° generally being employed.

In order to obtain maximum amplitude the mass of the feeder and the resilience of the springs are designed so that the natural frequency of vibration of each feeder system is a multiple of that of the power-supply frequency. The amplitude of vibration, and hence the rate of feeding, may be controlled by adjusting the magnetizing current.

INPUT FEEDER

Mixed screws and associated trash for sorting in the machine are fed manually into the hopper (D in Fig 6),

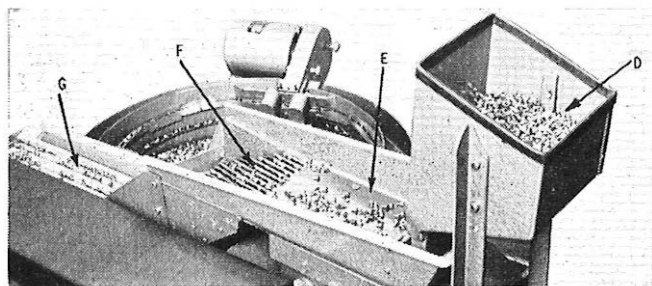

D—Input hopper E—Plain section
F—Sieving cascade G—Corrugated section

FIG. 6—INPUT FEEDER

which can take a charge of up to 10 lb. The lower end of the hopper discharges on to the table of the linear feeder, which consists of three parts.

The plain section (E in Fig. 6) provides a reasonably uniform flow of material from the hopper to the sieving cascade (F in Fig. 6), where loose washers, ends of wire, etc., are removed. The cascade consists of four layers of $\frac{3}{16}$ in. rods spaced so as to be just capable of supporting the heads of the smallest wanted screws. The centres of the rods in the different layers are staggered relative to each other and the lengths of the rods also differ within each layer (see Fig. 7). With this arrangement, washers, etc., which tend to remain with the screws by riding flat on one layer, are tipped on edge and fall between the rods of the next layer below. Items falling through the sieving section are collected in one container for disposal.

The third section (G in Fig. 6) is corrugated along its length to cause the screws to travel in four separate streams, where the watching operator removes any trash

that has survived the sieving cascade, or parts that are outside the scope of the sorting mechanism. Along

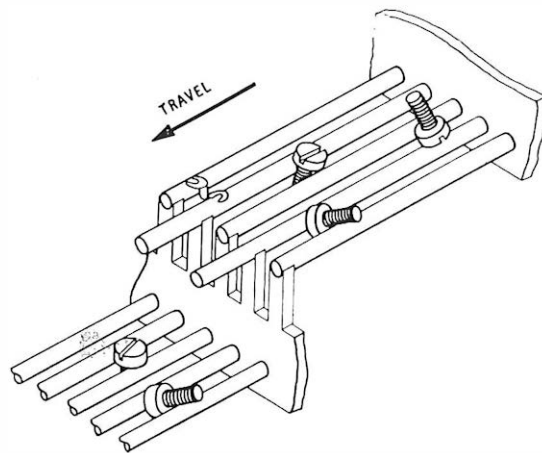

FIG. 7—SIEVING SECTION

the side of this section is a padded support for the operator's arms (see Fig. 1); this support has rubber mountings to avoid discomfort due to the vibrating action. Items removed are dropped into the disposal tray through slots placed on either side of the track. Screws at the end of the examination section fall down a chute to the bowl of the sorting machine.

The rate of feeding is controllable, and the operator adjusts this to maintain a constant level in the bowl of the sorting machine. The linear feeder is faster than the sorter, so that the operator can stop the feeder when auxiliary jobs—such as emptying a screw tray—become necessary.

SORTING MECHANISM

The sorting mechanism consists of two concentric cylindrical units mounted on the 24 in. vibrating table. Screws from the input feeder enter the centre section of the bowl and are raised by climbing a helical flight (or ramp) of grooved sheet metal around the inside of the outer rim of the central bowl. Most of the screws move with their axes along the groove; this enables them to enter the next section of flight correctly orientated. This flight is a rectangular channel with a vertical slot of sufficient width to allow the screws to travel with their threaded portion in the slot and with the under sides of the heads supported on the upper face of the flight. Should screws enter this track with the axis of the screwed portion at right angles to the direction of travel, they are removed by a guarding feature and fall into the bowl of the feeder, from whence they eventually re-enter the track.

The guarding operation is achieved by canting the track to 45° and providing a slot (H in Fig. 8) down which the screw slides back to the bowl. Such a guard precedes each sorting device as a safeguard against faulty sorting due to blockages.

Length-Sorting

Length-sorting of the screws is carried out by the device illustrated in Fig. 9. Screws above a given length are flipped out of the track, L, in which they travel, by means of a rocker arm, J, which hits the tips of the screws. Two similar rocker arms with a tip travel of

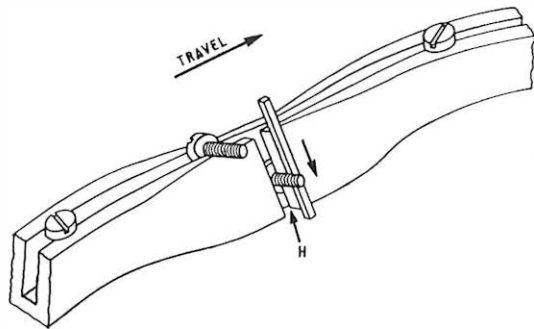

H—Slot for removing screws entering track incorrectly
FIG. 8—GUARDING FEATURE

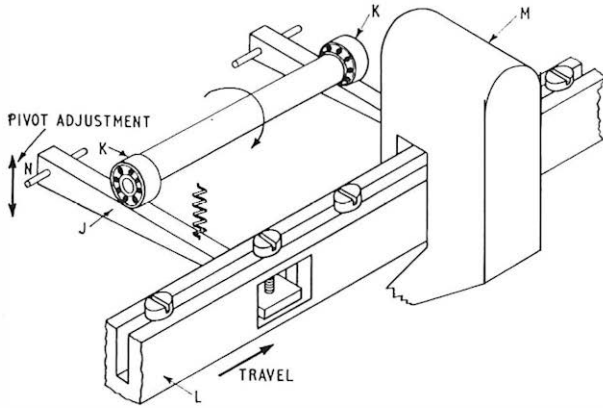

J—Rocker arm K—Eccentric L—Track
M—Metal Cover N—Pivot

Note: A cover, similar to M, is also provided to guide screws thrown up by the first rocker arm.
FIG. 9—LENGTH-SORTING UNIT

about 0.120 in. (normally set for $\frac{5}{16}$ in. and $\frac{1}{4}$ in. length of screws) are driven by eccentrics, K, on the ends of a common shaft, belt-driven at about 7,000 rev/min by a small induction motor. Because of the relatively high eccentric-shaft speed the rocker arms have been designed to have quite low inertia.

As the screws travel along the track, those whose lengths exceed the two predetermined lengths are hit on the tip of the thread by one of the rocker arms, fly upwards out of the rack and are guided onwards into a chute by the appropriate sheet-metal cover, M. Shorter screws remain in the rack and travel along to further sorting points. Pivoted flaps press down the heads of the screws in the track immediately in front of the rocker-arm sections to ensure that the undersides of the heads of the screws are in contact with the track as the length gauging takes place.

When correctly adjusted, by means of a screw adjustment to the height of the pivot N (Fig. 9), discrimination between screw lengths differing by less than 0.005 in. can be obtained, and screw flow rates of the order of 250 screws per minute can be dealt with. Mis-sorts at this point have not been found to average more than 1–2 per cent and there is no evidence of damage to threads.

Screws from the $\frac{5}{16}$ in. length-sorting mechanism are subjected to no further sorting and are discharged, but $\frac{1}{4}$ in. and $\frac{3}{16}$ in. long screws have to be sorted for head diameter, so that, after sorting for length, $\frac{1}{4}$ in. screws are passed to a track of the outer sorting ring while $\frac{3}{16}$ in. screws remain in the same track. Both sizes eventually enter a head-sorting unit.

Head-Sorting Unit

Screws are sorted for head diameter simply by increasing the width of the slot in the track in which the screws travel. This causes the screws of head diameter less than the slot width to fall into the bottom of the track, to be removed by a suitably positioned hole and chute. The larger-headed screws remain in the track and are further selected by successive increases in track width. To avoid jamming, the track is extended past the largest head slot to permit any mis-sorts to fall back into the bowl.

The head-sorter in the track of the outer sorting unit, Q (Fig. 10), deals with $\frac{1}{4}$ in. long screws of three

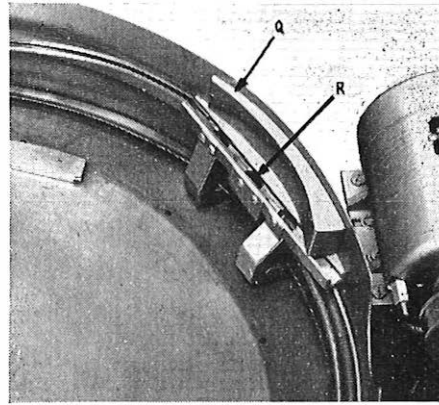

Q—Outer sorting unit R—Output chute

FIG. 10—HEAD-SORTING UNIT

head sizes. The middle-sized screws can be either of 4 BA or 5 BA thread size, and it is necessary to sort them for thread diameter. The output chute, R (Fig. 10), from the head-sorting unit for these two sizes of screws enables them to enter a further length of track, S (Fig. 11), on the outer-ring system along which they pass to the thread-sorting unit.

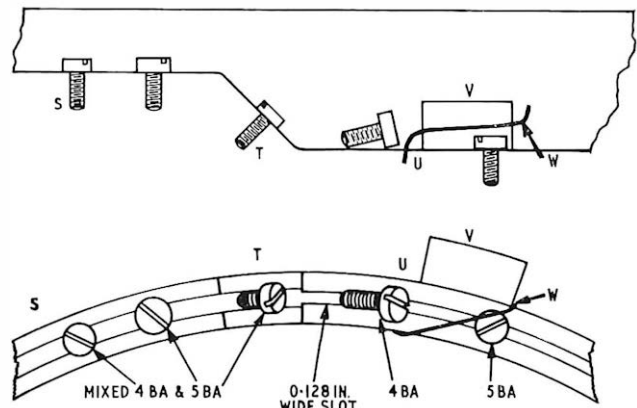

S—Channel-shaped track T—45° incline
U—Track with slot too narrow for 4BA threads
V—Cut-away side of track W—Plough wire
FIG. 11—THREAD-SORTING UNIT

Thread-Sorting Unit

In the thread-sorting unit the screws first travel in a length of channel-shaped track, S (Fig. 11), which at point T falls at 45° for about $\frac{1}{2}$ in. to the track U. The centre slot of this latter track is 0.128 in. wide, which is too narrow for the 4 BA screw threads to enter but

will accommodate the 5 BA thread. In descending the slope to this track, the screws travel with their heads tilted forwards, and this enables the 4 BA screws to travel entirely on top of track U, the 5 BA screws travelling vertically within the track suspended by their heads.

At point V (Fig. 11) one side of the track is cut away and the screws riding on top of the track are diverted from it by a plough wire, W, and enter a chute, the wire being fitted above the track with sufficient clearance to allow the "head-up" 5 BA screws to pass underneath to a further discharge chute at the end of the track.

PERFORMANCE

The machine described has proved capable of dealing with 30 lb/hour of mixed screws (approximately 500 screws/lb). The attendant operator is able to cope with

the manual work of removing the trash and moving unsorted and sorted screws without stopping the main sorting process. The quantity of mis-sorted screws appears to be less than 2 per cent. The gauging parts have been made so that they can readily be replaced if worn, but after two years' operation (sorting over 16 tons of screws) wear is not apparent. In comparison with this performance, to sort the same quantity of screws by hand would require four operators at least and there would be a greater liability to mis-sorting.

ACKNOWLEDGEMENTS

The authors wish to record their thanks to Mr. L. P. Wilson and the laboratory staff of Factories Department Headquarters whose patient work contributed much to the development of this machine.

"Meteorological and Astronautical Influence on Radio Wave Propagation." Edited by B. Landmarbe. Pergamon Press, Ltd. v + 318 pp. 140 ill. 100s.

This book is a miscellany of 14 papers read at the Nato Advanced Study Institute at Corfu, Greece, and forms the third volume of the Nato Conference Series.

In an otherwise excellently produced book, intended for the English speaking world, it seems a pity that five of the papers should be in French.

As might be expected from the source of the material the book does not form a comprehensive, progressive treatment of the subject but deals with a variety of topics in the field. The first two chapters are concerned with solar effects on propagation and the measurement of solar radio radiation. Two chapters, one in French, describe radio methods for studying the ionosphere and deal in detail with the E and F layers. Two more chapters, again with one in French, treat the troposphere from meteorological and radio-propagation standpoints while two more (one in French) deal with wave propagation in dielectric and ionized media. Propagation of waves in the h.f. band and at lower frequencies forms the subject matter of two further chapters. This leaves three papers, one on solar radio blackouts in English and, in French, papers on radio noise, atmospheric and radio meteors.

This is a book then which is something of a mixture both in material and language. Nevertheless, for the reader with a general interest in radio propagation there is much of interest, particularly in the introductory pages of the papers, while, for the specialist, particular papers will present an up-to-date statement of the art.

D.T.

"Ferrites at Microwave Frequencies." A. G. Gurevich. Heywood & Co., Ltd. viii + 332 pp. 93 ill. 140s.

The book is a translation by A. Tybulewicz from the Russian text by Gurevich originally published in 1960. In contrast to some Russian translations, it reads surprisingly smoothly and unambiguously. The treatment of the subject is thorough, covering first the magnetic properties of ferrites in weak microwave-frequency fields and then in intense fields.

The initial section commences with the analysis of isotropic ferrite and concludes with the effects of crystal anisotropy and domain structure. A large section, comprising about half the book, follows in which the behaviour of the media in the presence of steady fields is examined for both the infinite and bounded cases. This

section includes transmission through ferrite plates in rectangular waveguide, transmission through rods in circular waveguide and the design of resonators employing ferrites. A final, shorter, section relates to non-linear effects in which the applied fields are no longer weak. Detection, frequency conversion, oscillation and amplification are among the topics analysed in this section.

The book is well balanced and affords a comprehensive analytical treatment for the advanced student and research scientist. It is not an engineering design manual; there are only one or two descriptions of microwave realizations of ferrite devices in the whole of the book. A fundamental approach generally assures the maximum exploitation of the potentialities of a new technique, and the book under review should, by this means, stimulate originality in its own field.

A bibliography of 469 references, about a third of which are of Russian origin, is appended. Most of the remaining references are to works in English. A useful subject index concludes the book.

W.A.R.

"The Synthesis of Relay Switching Circuits." V. N. Roginskii. D. Van Nostrand Company, Ltd. 182 pp. 108 ill. 50s.

This book considers mainly those aspects of the subject studied in the U.S.S.R. and only briefly mentions the European and American efforts in this field. The translation is unfortunately not very good and this probably accounts for the occasional difficulties in understanding the text. Boolean algebra, which has generally been found very useful in this subject, is introduced as a preliminary to the author's graphical method for the synthesis of switching circuits. Various other algebraic devices are introduced, none of which are particularly effective. The discussion of what the author calls "orders of conductance" is difficult to follow and it is nowhere made clear what use can be made of the notion, nor is there any successful mathematical exposition.

The graphical method of synthesis described in this book, although not a great improvement on methods already in use (*vide* Caldwell, etc.) could be helpful in many cases.

Apart from this method there is very little of use in this book and while it should be studied by those who are expert in the subject it cannot be recommended as an introduction.

D.J.B.

A Transistor-Type Self-Synchronizing 7-Unit Monitor for Automatic Error-Correcting Radio-Telegraph Systems

D. A. CHESTERMAN†

U.D.C. 621.394.147.3 : 621.396.65

Since the introduction of the Van Duuren automatic error-correcting radio-telegraph system into commercial use in 1953, there have been continual improvements in equipment and maintenance techniques. The 7-unit monitor is used to examine the aggregate signal between automatic error-correcting terminals and is a valuable maintenance aid; a transistor version has now been produced.

INTRODUCTION

THE use of automatic error-correcting telegraph systems (ARQ) over h.f. radio links has been described in detail elsewhere;¹ however, it is useful to refer again to some of the principles involved. The system requires two terminals, one termed the master and the other the slave. Each terminal provides the facility of time-division multiplexing two or four channels, i.e. combining them in a predetermined cyclic order for transmission over a common path. By the use of a code whereby every transmitted character consists of seven elements or bits having a constant 3:4 polarity ratio, any received signals that do not comply with this criterion are detected as errors.

On the detection of an error the local receiving and transmitting machines at the customer's premises are stopped and a demand-for-repetition (RQ) signal is transmitted to the distant terminal. Upon receipt of this RQ signal both machines of the distant-end customer are stopped and the last three characters that were sent over the radio path are re-transmitted. This re-transmission is repeated until they are correctly received at the terminal that originated the demand for repetition.

To avoid the possibility of cross-channelling the multiplexed channels the polarity of the second, or B, channel (and the third, or C, channel in 4-channel working) is inverted. A further facility is that of sub-division whereby one or more full-rate channels are time-shared between customers requiring part-rate channels in multiples of one quarter of a full-rate channel; this permits the transmission of 100, 200 or 300 characters per minute instead of 400 at the full rate. Again, to prevent cross-sub-channelling, one character in four is inverted on each subdivided main channel. This latter safeguard has now been accepted as a C.C.I.R.* recommendation for all main channels, whether subdivided or not, and is known as the marked character cycle.²

The circuit logic to carry out these and other functions is necessarily complex. Hence, when a radio-telegraph circuit fails it may not be apparent immediately whether the failure is due to (a) the local ARQ receiver, (b) the local ARQ transmitter, (c) the radio path, including transmitters and receivers and associated land-line, or (d) the distant ARQ terminal. Further, it is not always convenient or even possible to contact the distant control terminal via another circuit. It is, therefore, very useful to be able to locate the fault rapidly without the necessity of interrupting

the circuit to substitute a spare ARQ equipment for the local terminal. The self-synchronizing 7-unit monitor has been introduced for such purposes.

FACILITIES

In order to simulate the function of an ARQ terminal receiver, the monitor has the essential facilities described below. It will operate to any double-current telegraph signal in the range ± 6 to ± 80 volts and presents a high-impedance input of 40,000 ohms. The input margin is about ± 49 per cent, and a polarity-reversing switch is provided. Keying can be accepted at $85\frac{1}{7}$, 96, 100, $171\frac{3}{7}$, 192 or 200 bauds.

Synchronization

Element or bit synchronism is defined as the condition existing when the timing of an element as determined by the local timing circuit coincides completely with an element of the received signal. It is very desirable that an ARQ receiver should incorporate automatic synchronization, and this facility is built into the monitor. Correction of asynchronism should be in steps of approximately 1 per cent of an element, i.e. for a 4-channel system operating at 192 bauds each element is 5.2 ms long, and synchronizing is effected by advancing or retarding the local timing in steps of 52 μ s.

To reduce jitter of the sampling period the early or late transitions of the monitored signal are integrated. This is achieved by two circuits, one of which counts eight early transitions and the other eight late transitions. These circuits are separately reset when the appropriate advancing or retarding step has been taken.

A switch is provided to inhibit synchronizing if necessary.

Phasing

Character phase exists when a character cycle as controlled by the local timing circuit completely coincides with a character cycle of the received signal. Automatic phasing is incorporated in most modern ARQ equipments and the criteria for determining when an out-of-phase condition exists have been carefully compiled from operational experience. As a result of these safeguards it is almost impossible for the equipment to find, and maintain, false phase. An independent monitor cannot apply the same stringent tests if only because there is no way in which it can determine readily what is happening at either terminal, whereas the terminal equipment has an inbuilt store to indicate (a) normal traffic, (b) cycling to RQ signals, and (c) cycling to errors.

The out-of-phase criterion employed in the monitor is that of "minimum errors."³ An adjustable error-count per 10 received-character periods is controlled by a 5-position switch, labelled 1-5 ERRORS, and whenever the selected count is equalled a phase step is taken. In poor radio conditions unnecessary phase-stepping may take place due to the receipt of random bursts of errors, suggesting the use of the maximum setting of 5 errors

†Telegraph Branch, E.-in-C.'s Office.

*C.C.I.R.—International Radio Consultative Committee.

in 10 received-character periods; this would, however, reduce the speed of automatic phasing. A red lamp flashes for every error received and another lamp indicates when auto-phasing is in progress. A manual phasing button is provided and semi-automatic phasing can be employed if required.

Traffic Presentation

Providing that the monitor is not phase-hunting, all the 7-unit signals received on the selected channel are displayed on lamps and offered to a special 7-unit tape printer. The 32 teleprinter combinations will be recognized by the printer and printed appropriately. In addition, a special symbol indicates the receipt of an error, i.e. a non 3:4 ratio combination, and another symbol is used for the receipt of the RO combination. The receipt of the idle-condition alpha or beta signals is not recognized by the printer and it is necessary to rely on the lamp display to identify these combinations.

Sub-Division

Any full character-rate channel may be subdivided, i.e. shared between two, three or four customers, by cyclic time-division on a character basis. The output-to-printer circuit is controlled by four switches, each one controlling the printing of one separate character in every four received. Hence, any subdivided channel

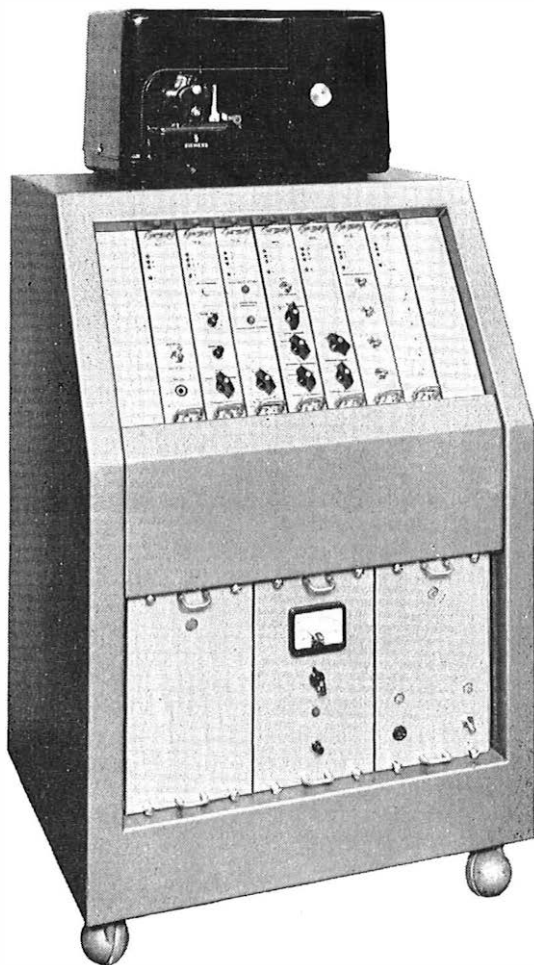

FIG. 1—SEVEN-UNIT MONITOR FOR AUTOMATIC ERROR-CORRECTING RADIO-TELEGRAPH SYSTEMS

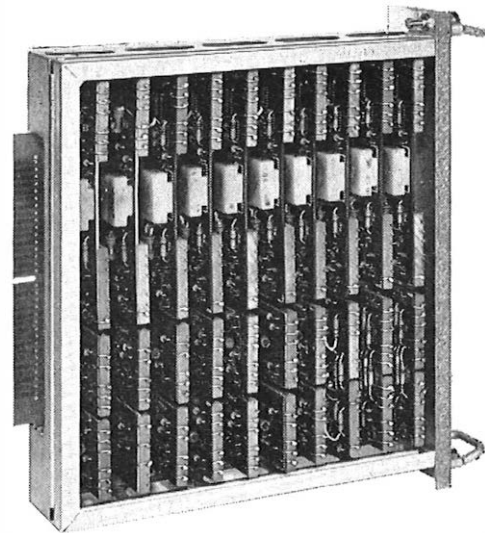

FIG. 2—APPARATUS "BOOK"

operating at any of the available rates can be selected readily. A full-rate circuit is monitored by operating all four switches.

Marked Character Cycle

The monitor can operate to non-marked or marked character cycle with the 4-character or 8-character repetition cycle, selection being by means of a 3-position switch. The 4-character marked-cycle switch position is always required with sub-division, and the 8-character marked-cycle position is used to monitor circuits with abnormal propagation time, e.g. London-Sydney relayed circuits.

CONSTRUCTION

The monitor (Fig. 1) is entirely mains operated and comprises seven "books" (Fig. 2) each containing a number of rationalized modules; printed wiring is used throughout. Two power units and a crystal oscillator are mounted below the monitor. The complete unit is accommodated in a trolley-type cabinet with space on top for the 7-unit tape printer. A console version is being manufactured for use in engineering radio-control positions at AR● centres.

CONCLUSION

A prototype monitor has been on continuous field trial for over a year without any fault developing. It has proved to be a valuable and reliable tool for the maintenance of international radio-telegraph circuits.

ACKNOWLEDGEMENT

Acknowledgement is made to Marconi's Wireless Telegraph Co., Ltd., for permission to reproduce the photographs.

References

- ¹CROISDALE, A. C. Teleprinting over Long-Distance Radio Links. *P.O.E.E.J.*, Vol. 51, p. 88 and p. 219, July 1958 and Oct. 1958.
- ²CROISDALE, A. C. Improvements in Automatic Error-Correcting Equipment Used on H.F. Radio Telegraph Services. *P.O.E.E.J.*, Vol. 55, p. 253, Jan. 1963.
- ³FROOM, R. P., LEE, F. J., HILTON, C. G., and MACKRILL, P. A Monitor for 7-Unit Synchronous Error-Correcting Systems for Use on Radio-Telegraph Circuits. *P.O.E.E.J.*, Vol. 53, p. 1, Apr. 1960.

Air-Conditioning in Computer Accommodation

M. STEPHENSON, A.M.I.E.E., and R. G. FIDDES, B.Sc.(Eng.), A.M.I.E.E.†

U.D.C. 628.84:681.142

The environment for a computer must be very carefully planned to enable the computer to operate reliably and also to provide comfortable working conditions for the operating staff. Thus, the air temperature and relative humidity must be maintained within certain limits all the year round and the air kept dust free. The limits necessary for the correct operation of modern computers are described, together with methods of controlling the environment.

INTRODUCTION

THE environmental requirements for electric computers have changed considerably since their inception for automatic data processing (a.d.p.) about 10 years ago. Early computers were thermionic-valve equipments with heat dissipations of 70 kW or more, giving an average heat dissipation of up to 25 watts/ft². For comparison, it should be noted that a typical value for a repeater-station apparatus room¹ is 10–12 watts/ft². Ventilation systems were, therefore, needed to extract the heat from the computer equipment to prevent a dangerous rise in temperature and to provide satisfactory conditions for the operating staff. For these purposes, direct air-extraction systems were generally adequate.

The addition of magnetic tapes to computer systems imposed more onerous requirements on the environment as they require dust-free conditions and control of relative humidity (r.h.) for satisfactory operation. Dust between the tape and the reading and writing heads can cause errors, and large dust particles may permanently damage the magnetic-oxide coating on the tape. Control of r.h. is necessary because the tape material is subject to dimensional changes with changes in r.h., and at low r.h. the presence of static electricity may cause irregularities in tape movement.

Modern computers use transistors and, consequently, the heat produced is considerably less than that of valve equipments, but the permissible temperature rise within the transistor-type computer is also less, with an upper limit of 80–90°F. However, since nearly all new computer installations employ a number of magnetic-tape units, each of which dissipates about 2 kW, these generally determine the environmental conditions to be provided in the computer accommodation.

Paper tape, punched cards and stationery used with high-speed readers and printers also suffer static effects at low r.h. and dimensional changes with variation of r.h., and the operation of these all benefit from improved air conditioning.

TYPICAL AIR-CONDITIONING REQUIREMENTS

Although slightly different requirements are quoted by different computer manufacturers, the general ambient air conditions required are:

- (a) a temperature of $70 \pm 5^\circ\text{F}$,
- (b) relative humidity of 50 ± 10 per cent, and
- (c) air filtration with 95 per cent efficiency for particles above 5 micron.*

†H.M. Treasury Automatic Data Processing—Technical Support Unit, E.-in-C.'s Office.

*micron—0.001 mm.

Variations of these conditions range from:

- (a) a temperature of $70 \pm 3^\circ\text{F}$ to one of $70 \pm 10^\circ\text{F}$.
- (b) relative humidity of 50 ± 5 per cent to 40–65 per cent, and
- (c) air-filtration efficiencies of 99.9 per cent for particles above 1 micron to 90 per cent for particles above 6 micron.

To ensure that the general air conditions are met at all seasons, it has been agreed with the Ministry of Public Building and Works, who are responsible for the air-conditioning plants for Government Department computers (other than those in the Post Office), that they will provide plants to give controlled conditions in a temperature range of $70 \pm 3^\circ\text{F}$ and a relative humidity range of 50 ± 5 per cent, and that, where a computer manufacturer asks for more stringent dust control than is generally required, every effort will be made to meet his requirements. The cost of any elaboration in the air-conditioning plant and accommodation needed is, of course, taken into account when assessing the relative merits of various competitive computer systems.

Since the magnetic-tape units are the items which require the most stringent conditions, it is usually arranged for the sensing control of the air-conditioning plant to be sited near the tape units and at about 4 ft above floor level. A thermo-hygrograph is provided in the computer room to continuously record the conditions, and a typical chart is shown in Fig. 1.

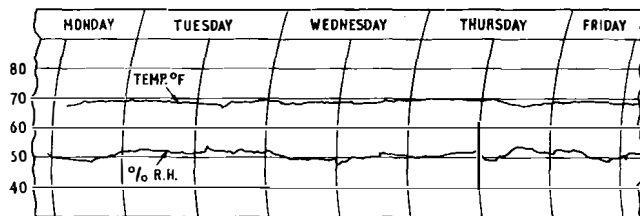

FIG. 1—THERMO-HYGROGRAPH RECORDING FROM A COMPUTER INSTALLATION

Fortunately, the air conditions required for the equipment are also ideally suitable for staff comfort and, although it may appear at first sight that temperatures of 70°F or over are high, it is found that with a moderate flow of air these temperatures result in very comfortable conditions. Particular attention has to be paid to the problem of air movement, not only to avoid draughts, which would cause discomfort to staff operating the equipment, but also to prevent disturbance of paper-handling machines, such as paper-tape readers and high-speed printers.

The same standards of air conditioning as provided in the computer area are also required in the maintenance engineers' accommodation and the magnetic-tape store.

GENERAL COMPUTER-EQUIPMENT LAYOUT

In all computer equipments, the operational controls are intimately associated with the mechanical and electronic working parts, and so the units are designed as individual self-contained items styled for office installation. Nearly all equipments are cooled by



Magnetic tape units in foreground. Conditioned air is supplied by ceiling diffusers

FIG. 2—GENERAL VIEW OF A LARGE COMPUTER INSTALLATION

drawing in room air near the bottom of the cabinets and exhausting it back into the room from the top. The layout of the computer is arranged to facilitate work flow, to allow adequate space for the movement of trolleys and to provide the operator at the control desk with the best possible view of all control elements. Most of the equipment is located in a fixed position, but some items, such as printers and magnetic-tape units, are fitted with castors to enable them to be wheeled into the maintenance area for engineering attention. All these factors mean that a regular layout—in the sense of uniform suites of equipment racks familiar to communication engineers—is not possible, and, consequently, it is necessary to provide air-conditioning to the whole computer room rather than

to the individual equipments. Efforts are, however, sometimes made to extract room air in the immediate vicinity of the main heat-producing items. A typical large computer installation is shown in Fig. 2.

METHODS OF PROVIDING CONDITIONED AIR

A simplified block schematic diagram of a typical air-conditioning system is shown in Fig. 3.

Temperature Control

To maintain the temperature within the specified limits, the air-conditioning system must be capable of both adding and removing heat, and this is achieved by the provision of heat exchangers in the airflow. Heating of the air is necessary to produce the required r.h. after dew point has been reached in the humidifier. The heating section is usually electrical, but low-pressure hot water or steam is used if its supply is guaranteed all the year round.

Cooling by the circulation of air has been described in an earlier article¹ in this Journal. If such an arrangement were applied to a modern computer installation the air circulation would be exceptionally high and the r.h. uncontrolled, and under hot summer conditions the upper temperature limit could be easily exceeded. The environmental standards required for a modern computer can only be satisfactorily obtained by using a full air-conditioning system in which heat is removed from the air either by a heat exchanger in which chilled water or cold refrigerant gas is passing, or by means of a spray of chilled water through which the air must pass.

The cooling capacity of a refrigeration plant is usually expressed in "tons of refrigeration", 1 ton of refrigeration being a heat-extraction rate of 12,000 B.t.u./hour. A medium-sized a.d.p. computer installation requires between 10 and 20 tons of refrigeration, but larger

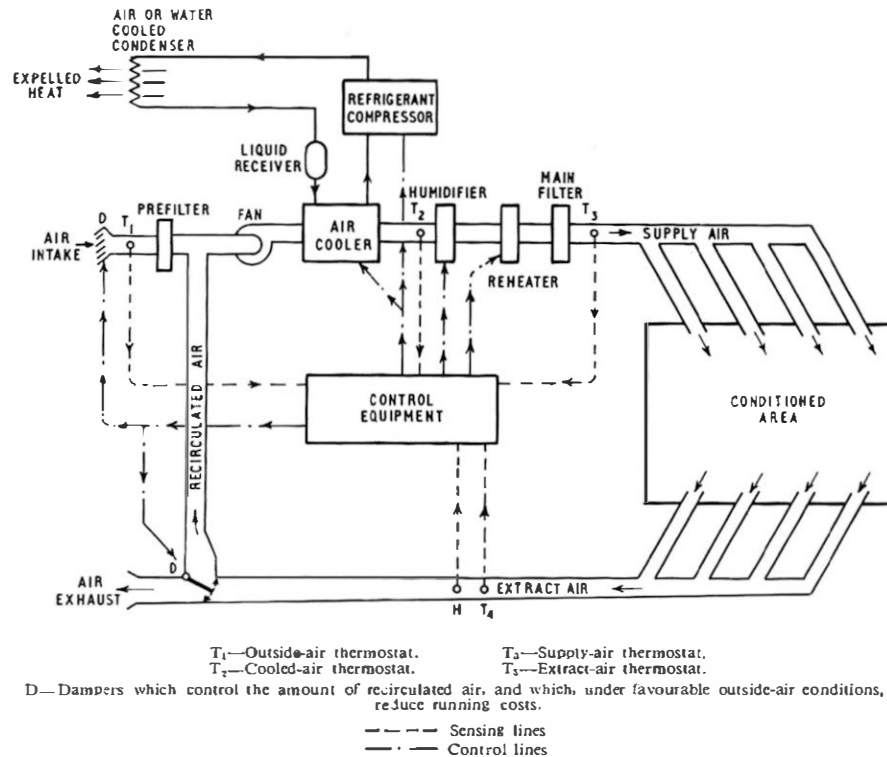

FIG. 3—SIMPLIFIED BLOCK SCHEMATIC DIAGRAM OF AN AIR-CONDITIONING SYSTEM

computers requiring plants of up to 75 tons of refrigeration are not uncommon.

Humidity Control

The upper limit of relative humidity is controlled by cooling the air to remove the excess water by condensation. This process requires the use of the refrigeration plant, which at times may be called into service solely for this purpose. The lower limit of r.h. is controlled by adding water to the air in one of two ways. In one method, a spray chamber supplies sufficient water to saturate the cooled air at a controlled temperature (usually about 50°F). When this air is reheated to about 70°F the required relative humidity of 50 per cent is obtained. In the other method, water is added, by steam jets, evaporator pans or spray disks, as required by the control system.

Dust Control

Dust control is achieved by filtering the air before passing it into the rooms and by arranging for the rooms to be slightly pressurized to resist the ingress of dust. The vitiated air is extracted and reprocessed for recirculation so that, by controlling the input, extract and make-up air, a reasonable degree of pressurizing can be obtained. This is usually specified as 10 per cent of the air in circulation rather than in units of pressure. Air locks are provided at the entrances to the air-conditioned areas to preserve this pressure. As an additional safeguard against dust, special mats are sometimes provided in these entrances. These mats are impregnated with a special adhesive which removes loose dust from the soles of footwear.

Methods of achieving air filtration^{1,2} will not be described in detail here. The efficiency of viscous filters is too low for them to be useful for computer air-conditioning plants. Considerable use has been made of the "Kompak" type filter, however, for which a flame-proof filling is obtainable, and this filling has been adopted as an extra security feature at one installation. Some recent installations are using the roller type of filter, which is fitted with a heavy-duty medium to meet the filtration requirements; it offers the advantages of automatic feeding of the filter medium, alarm indication at the end of the roll, speedy replacement and low risk of dust being carried into the duct system at the time of filter replacement. Such a filter is shown in Fig. 4.

As mentioned earlier, computer manufacturers are requesting more and more stringent filtration standards and specify them in various ways. One, for example, calls for filtration efficiencies of 95 per cent at 5 microns, 87 per cent at 3 microns, and 50 per cent at 1 micron. On the other hand, filter manufacturers quote filter efficiencies in terms either of Aloxite 50 standard test dust, which has a mean particle size of 5 microns, or of methylene blue, which has a mean particle size of approximately 0.4 micron. It is, however, extremely difficult to deduce from these figures how well a filter will perform in any particular situation since the composition of the dust at a computer site may vary considerably, both in particle sizes and density, from that of the test dusts. The trend is to adopt double filtration in which a pre-filter is used to arrest the coarse particles of the dust, followed by either an absolute filter or an electrostatic precipitator.^{1,2} Special attention must be given to the wash-cleaning arrangements for electro-

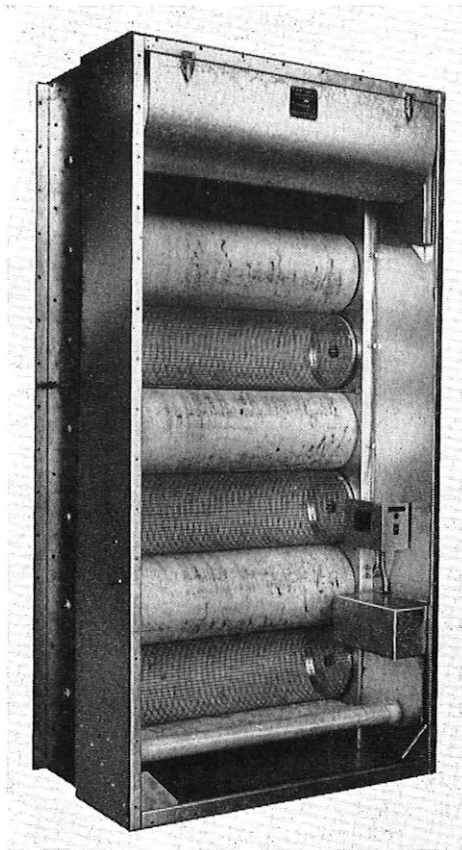

FIG. 4—AUTOMATIC ROLLER-TYPE FABRIC AIR FILTER

static precipitators to ensure that the filters can be dried quickly after washing without passing damp air into the air-conditioned rooms, and arrangements are incorporated to cut off the air flow and warn the computer staff in the event of failure of the e.h.t. supply.

AIR FLOW IN COMPUTER ROOMS

The forced ventilation of the computer equipment by means of small built-in fans introduces air-flow problems for the air-conditioning engineer. In general, computer equipment exhausts air vertically upward, but the quantity of air exhausted and its temperature may vary considerably between different types of equipment and between manufacturers. The discharge velocity of this air ranges from 50 to 500 ft/min and can have a temperature as high as 110°F for mechanical equipment, though 85°F is a more likely maximum for transistor-type equipment. The actual heat dissipations range from $\frac{1}{2}$ kW for small data-processing bays to 5 kW for power-supply cubicles.

Another variable to be considered is the temperature gradient between the supply and return air, and this is left to the discretion of the design engineer who has to ensure that the mean specified conditions are achieved. Within the computer room, it is desirable to have the smallest practicable temperature gradient. For a given heat load, however, the gradient is related to the number of air changes, and too small a design gradient may require excessive air movement, which in turn can be uncomfortable for operators and may disturb the paper in printers and paper-tape readers.

It is not surprising that, as a result of these wide

variations in ventilation features of the equipment, a variety of air-flow arrangements have been employed in the air-conditioning systems installed to date. Whenever possible, the extract system is arranged to collect the heated air from directly over the main heat-producing equipment to prevent this hot air from circulating in the computer room. Where this can be done without imposing restrictions on the layout of the computer equipment, it is possible to achieve a large temperature gradient and to minimize air movement. The minimum input temperature is usually fixed in the range 65–68°F, but the actual input temperature at any time will vary with the heat generated by the equipment. There are, however, one or two systems that are designed to operate to lower minimum input temperatures, and with these systems the required room condition is obtained by blending the supply air with exhaust air from the computer cabinets.

Another variation in the method of supplying air is to provide conditioned air directly in ducts to the computer cabinets, but this arrangement is not in widespread use at present. In such systems the air from the computer cabinets is usually discharged into the room, and so the air must have a moisture content which satisfies the humidity requirements of the room. This usually means that the air-supply temperature cannot be lower than about 61°F if condensation in the ductwork and input areas of the computer equipment is to be avoided at all times.

It is worthwhile recording that in spite of the widely different practices and philosophies on air flow adopted by the engineers responsible for these systems, all have been satisfactory in operation.

CONTROL SYSTEMS

It is beyond the scope of this article to consider control systems in detail, but since the performance of the installation depends largely upon the method employed, some mention must be made of the current trends in control-system design. There are various ways of controlling the final temperature and humidity, and at present no universally-accepted technique has been adopted by the various control-system specialists to whom this work is usually sub-contracted.

The important thing from the computer point of view is that the air-conditioning system should be highly reliable, and for this the simpler the control system the better. There is a tendency for both the mechanical and electrical features of control systems to be complicated and this necessitates specialist treatment both for routine maintenance and for fault clearance. In some instances, this has been aggravated by a demand from some computer manufacturers for a very close control of the temperature and humidity.

The moisture content is sensed either by a thermostat situated at a point in the system where the air is saturated (dew-point control) or by humidistats mounted in the room or in the return-air ducts giving a direct indication of the relative humidity of the conditioned accommodation. The most commonly-used humidistats rely upon detecting a change in the length of animal or vegetable fibres with a change of relative humidity, and they are usually installed in the rooms concerned. They respond more slowly to changes of humidity than the thermostats used with dew-point control systems and are subject to calibration drift.^{2,3}

Lithium-chloride humidistats are now appearing in some installations but as yet there is insufficient experience of them in a.d.p. installations to permit a comparison with other methods of sensing humidity.²

The temperature is usually sensed by dry-bulb thermostats of the bellows type, or the bimetal type of which both the rod and strip types may be used for duct and room mounting. Owing to the difference in heat loadings of various rooms, e.g. between the computer room and the tape library, a thermostat and air reheater are provided for rooms in which the heat loading is insufficient to maintain the temperature required. Thermostats are also used with chilled-water systems to take external conditions into account and to give frost protection.

DETERMINATION OF TOTAL HEAT LOAD TO BE HANDLED BY THE AIR-CONDITIONING PLANT

The size of the air-conditioning plant for a given installation is determined by considering the room heat loads, solar gain, the thermal properties of the building and psychrometric requirements for the processed air.

Room Heat Load

The heat load is made up of all the items that give off heat in the air-conditioned area. Of these, the electrically-energized items, such as the computer, its associated equipment and lighting, are regarded as converting all the electrical energy input into heat. Allowance should also be made for staff but this, at about 500 B.t.u. per hour per person,⁴ is usually negligible by comparison with the other factors.

Solar Gain

The heating power obtained in the summer by solar radiation can be as high as 250 B.t.u. per hour per square foot of ground area. This, therefore, is an important factor for contemporary buildings employing extensive glazing on outside walls. Although various proprietary glazing techniques can reduce solar gain, the direct sunlight entering a computer room may fall on and heat up items which can be adversely affected, e.g. punched cards and paper. It is, therefore, desirable to minimize the glazing or to fit canopies outside the windows. Curtains and venetian blinds are not favoured as they harbour dust and add considerably to the cleaning problems, while much of the radiant heat which they intercept is still liberated inside the rooms and has to be handled by the air-conditioning plant.

Thermal Properties of the Building

The thermal properties of the building must be evaluated in much the same way as for the provision of central heating. In general, the building should have good thermal properties to ensure that the peak heat load due to heat transfer into the room under heat-wave conditions is as low as possible. This will also make it easier to achieve the required conditions using background heating during periods in the winter when the installation is closed down. Moreover, when the plant is running in the winter the loss of water vapour due to condensation on the walls and windows of the rooms will be prevented. Double glazing is especially important in this respect, although the use of metal frames for double-glazed windows has been known to cause

condensation in the winter due to the metal offering a cold surface to the conditioned air.

Psychrometric Requirements

As mentioned in the paragraph on humidity control, the refrigeration plant will be called into operation to remove excess water from the air. The psychrometric requirements are usually well within the refrigeration-plant capacity needed to cover the other factors.

ACCOMMODATION REQUIREMENTS

Fig. 5 gives a view of the plant room accommodating

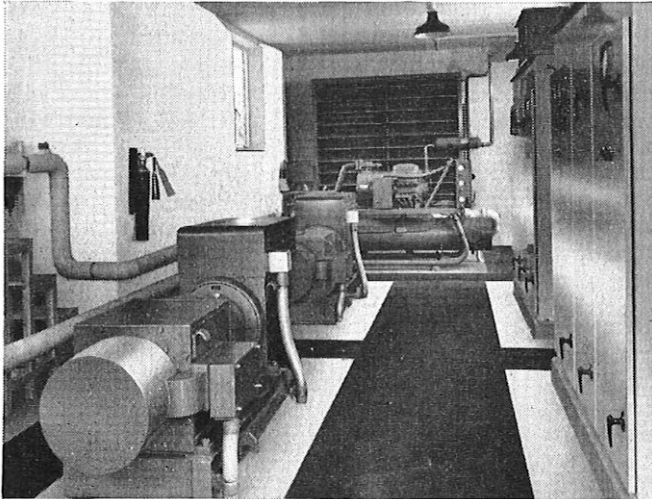

Two buffer alternators in the foreground with associated control cabinets to the right. In the background can be seen the high-speed compressor and air-cooled condenser. These are rated at 13 tons of refrigeration.

FIG. 5—COMBINED POWER AND AIR-CONDITIONING PLANT ROOM

a 13-ton plant for a medium-size computer installation. In the foreground are two mains-buffer alternators for the computer power supplies (computers do not usually need buffer alternators for their power supplies but, when they are required, joint usage of the plant room is satisfactory for small installations). Fig. 6 and 7

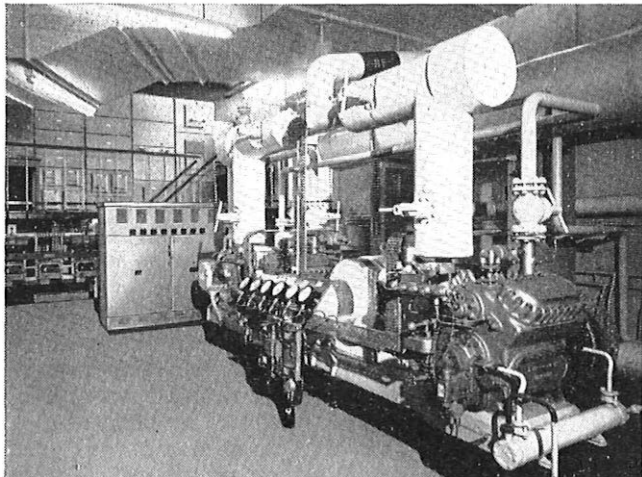

Two low-speed compressors in the foreground giving a total refrigeration capacity of 75 tons. Control equipment is shown in the background.

FIG. 6—PLANT ROOM

show two sections of the 75-ton plant serving the large computer installation shown in Fig. 2.

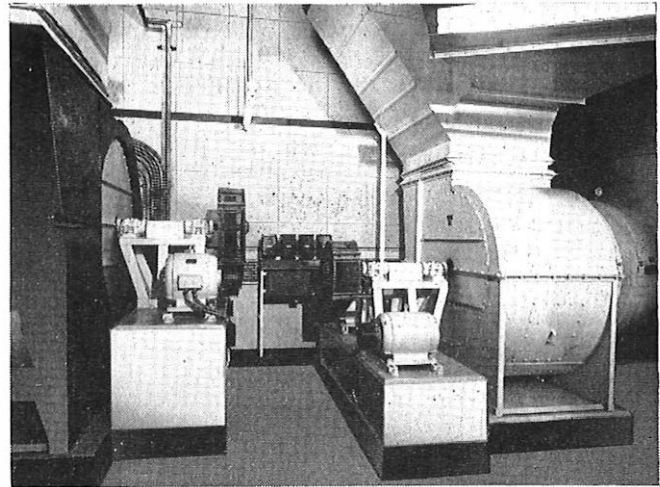

Supply fan (left) —33,300 ft³/min; extract fan (right) —27,900 ft³/min.

FIG. 7—PLANT ROOM SHOWING SUPPLY AND EXTRACT FANS AND STANDBY MOTORS

Noise

Fans, motors and compressors are the main sources of noise in air-conditioning plant rooms, and, in general, the frequency content of the noise depends upon the design of the compressors. Slow-speed compressors produce low-frequency vibrations, which can be directly transmitted through building foundations and walls, but these effects are reduced by the use of anti-vibration bases. High-speed compressors, on the other hand, require much lighter mountings and do not produce troublesome low-frequency noise. As explained later, it is desirable to have the plant room as near as possible to the area to be air-conditioned, and, although the computer room itself is moderately noisy due to the operation of magnetic-tape units, printers and punched-card machines, the plant-room noise should be attenuated to reasonable limits before reaching the computer room. More important, however, is the need to reduce the plant noise reaching adjacent office accommodation. In planning new buildings, it is desirable to keep office accommodation well away from the air-conditioning plant room, while in adapting existing buildings considerable care is taken with acoustic treatment and choice of plant to achieve a satisfactory result.

Duct Runs

Ducts must be lagged since they will often carry air that is at a different temperature to the surrounding air. The ducts, which ideally will have a cross-section that is either circular or square, should be as short as possible and have a minimum of bends. These requirements can be met most economically where the plant room is sited near to the area to be air-conditioned.

In the plant room itself, ductwork may often need to undergo a number of cross-section transformations to suit the different dimensions of the fans, heat exchangers and filters, so that, together with the need to have smooth bends and effective lagging, the ductwork may require a comparatively large amount of space.

Air Intake

To give the pressurization referred to earlier, it is usual to provide a fresh-air intake supply of at least 10 per cent of the circulated air. The fresh-air supply

should be as clean as possible, and be free from corrosive gases, boiler-chimney fumes, stationary-engine exhaust gases, etc. The effects of rain, prevailing winds or sunshine on this intake are generally unimportant.

Condenser

The condenser may be either air-cooled or water-cooled, and may be sited inside the plant room or outside the building (see Fig. 8 and 9). The use of an external

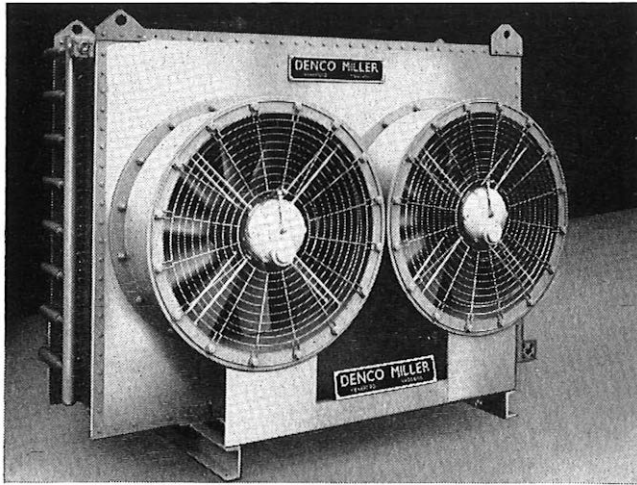

Cooling rating: 432,000 B.t.u./h. Fan air flow: 14,000 ft³/min each.
Fan power rating: 2½ h.p. each. Size: 7½ ft wide, 5 ft high.

FIG. 8.—AIR-COOLED CONDENSER

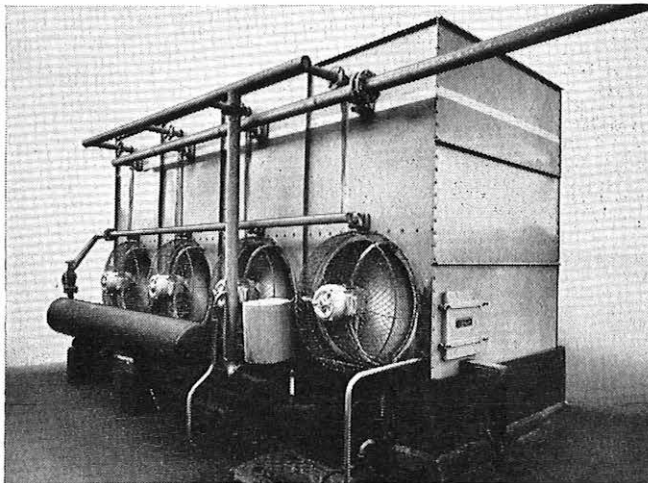

Cooling rating: 900,000 B.t.u./h. Fan air flow: 10,000 ft³/min each.
Fan power rating: 2 h.p. each. Size: 16 ft long, 6 ft wide, 8 ft high.

FIG. 9.—WATER-COOLED EVAPORATIVE CONDENSER

condenser saves space in the plant room, but if the water-cooled type is used the risk of it freezing up in winter time is increased. Although an external water-cooled condenser can be protected by built-in electrical heaters and lagging, there is always the risk of frost damage due to failure of the heaters or of the power supply. Air-cooled condensers are free from this risk but are less effective under heat-wave conditions, and this tends to limit their applications to the smaller plant sizes. One contractor offers a combination of these two systems in the form of an air-cooled condenser that also has a

water-wash arrangement. The water spray is thermostatically switched on during heat-wave conditions, while in the winter the water supply pipe-work is drained to avoid frost damage.

Condensers need a generous supply of air, and so, when mounted in a plant room, are usually built into an external wall. All the heat removed by the refrigeration cycle is exhausted through the condenser so that a considerable amount of hot air is expelled at this point. It is obviously undesirable to draw any of this exhaust air in by the make-up air intake, and the siting of these two items is carefully arranged to avoid this.

Plant-Room Ventilation

The plant room needs to be well ventilated to prevent over-heating of motors, bearings, compressors, etc., but it must also be reasonably frost-proof while under idle conditions. Ventilation can be provided by the condenser fan, and this method is used for the plant room shown in Fig. 5. Here the air-cooled condenser is mounted in the far wall of the plant room and its fan draws 16,000 ft³/min of air through the plant room from low-level intake louvres; these louvres are not shown in the photograph.

Services

The plant room will require electricity, water and drainage services. In some localities the water may have to be treated to inhibit the rapid furring-up or rusting of condensers and heat exchangers.

A 3-phase electricity supply is required, typical capacities for large plants being as follows:

Plant Size in Tons of Refrigeration	Maximum Electrical Consumption (kW)	Background and Reheat Services Employed
80	70	Low-pressure hot water (l.p.h.w.)
75	220	Electric

The higher electrical power required in the second example is mainly due to the background heating. This is usually required only at nights and weekends so that where an off-peak tariff is available this arrangement can be economical. It is unusual to find Government accommodation in which l.p.h.w. or steam heating can be offered economically and guaranteed to be available continuously throughout the year for the air-conditioning plant.

MAINTENANCE OF CONDITIONS WHEN COMPUTER IS NOT IN USE

Many computer manufacturers seek to obtain the same environmental conditions when the computer is switched off as when it is working. Their concern is to prevent any temperature cycling of the magnetic tapes. Other manufacturers, however, accept relaxed limits during off periods. Except for installations which are operating on a three-shift basis, all Government Department installations switch off the air-conditioning plant at night and at weekends. That gives some economy in plant operation and a reduction in fire risk. In order to provide some control over ambient conditions within the computer accommodation, it is usual to provide electrical background heating under thermostat and humidistat control. This heating is provided to prevent low temperatures or high r.h., or both, arising when the

computer is switched off, it being accepted that on a hot summer weekend the indoor temperature could rise to possibly 85–90°F. This should not harm the computer equipment which, under normal working conditions, can be expected to have local hot spots in excess of these temperatures. Nor will it harm the magnetic tapes, although, in order to reduce the risk of errors, a short conditioning period in the operational environment may be necessary before they are used.

In winter when the outside temperatures are low, it is possible for the indoor relative humidity to fall below the 40 per cent limit. Magnetic tapes are, however, usually stored in plastic containers which, although not completely air tight, are sealed well enough to make it unlikely that there would be any appreciable loss of moisture from them over short periods of time. Moreover, if thermostatic control of the background heating has maintained the room warm enough to avoid condensation from the moisture-enriched air when the air-conditioning plant is switched on, the ambient conditions within the computer accommodation can quickly be restored before the installation is required for operational use.

In the computer installation shown in Fig. 2, background heating is provided by 3 kW unit fan heaters mounted at a high level on the walls of the room.

RELIABILITY

To ensure that the computer can be operational whenever it is required, the reliability of the air-conditioning plant should be of the same order as that of the computer.

The most likely cause of an extended shut down of the air-conditioning system is a failure of the compressor, and arrangements for the security of the plant vary from the provision of a standby compressor and motor to the provision of two compressors each capable of providing 60–70 per cent of the total refrigeration load. The latter is the more economical, and the risk of a compressor failure occurring on one of the few occasions when both are required is one which can usually be accepted. Many of the other items are standard engineering units (motors, pumps, control equipment, etc.), and the basis of provision of spares depends upon the ease with which they can be obtained from the manufacturers, the aim being to ensure that the plant should not be out of service for more than one shift.

From discussions with the various maintenance engineers, it was found that attention to the compressors was necessary at four out of seven installations within the first few weeks of operation; in three instances, the work was carried out without interruption to the computer. At four installations, the plant suffered frost

damage during the cold spell at the end of December 1961. Other faults have occurred which indicate the need for a more thorough examination and testing before the plants are accepted from contractors.

CONCLUSIONS

The development of the computer as an office machine has brought with it a commercial demand for air-conditioning equipment of high reliability to meet the more exacting requirements imposed by changes in computer techniques. The early requirement of merely removing heat from thermionic-valve equipment has now been extended to include humidity and dust control for computers using magnetic tape. These improved environmental conditions have resulted in more reliable operation of paper-tape and punched-card machines. These mechanical units often limit the speed at which the computer systems can work and the trend is to increase their speed of operation. While this course is maintained, the air-conditioning requirements are likely to remain stringent.

Opinions on the degree of air filtration required are by no means unanimous. No conclusive evidence on the effects of fine dust upon performance has been offered by any computer manufacturer in dealings with the authors on the subject. This is partly due to the lack of experience in the use of magnetic-tape systems, and partly due to the great difficulty in collecting conclusive data. However, it seems that air filtration will be required, if only as an insurance against an unknown risk, for many years to come, and a considerable amount of research, both on the performance of the computer equipment and the measurement of air-filter efficiencies, is necessary before it will be possible to specify the optimum filtration standard for a particular locality.

ACKNOWLEDGEMENTS

The authors wish to record their thanks to the Ministry of Public Building and Works and the Ministry of Pensions and National Insurance for the use of the photographs shown in Fig. 2, 6, 7 and 9, to the Admiralty for Fig. 5, to Denco Miller, Ltd., for Fig. 8, and to Oxonair Engineering Co., Ltd., for Fig. 4. They would also like to record their appreciation of helpful discussions on air-conditioning with many colleagues.

References

- ¹HOPWOOD, R. W. Ventilation of Apparatus Rooms. *P.O.E.E.J.*, Vol. 54, p. 225, Jan. 1962.
- ²SPULBECK, H., and STEINKUHLER, K. H. Air-Conditioning in Switchrooms. *Der Fernmelde Ingenieur*, May 1959.
- ³Notes on Applied Science No. 4—Measurement of Humidity. *National Physical Laboratory*, 1958.
- ⁴BEDFORD, T. Basic Principles of Ventilation and Heating. (*H. K. Lewis & Co., Ltd.*, 1948)

Twenty-One Years of Submarine Repeaters

R. A. BROCKBANK, O.B.E., Ph.D., B.Sc., M.I.E.E.†

U.D.C. 621.375.2:621.395.64:621.315.28

This article recalls the historic occasion of the laying of the first-ever submarine repeater—a British one—21 years ago. It then reviews the developments which have led up to the present extensive ocean network and to the possibilities of much greater bandwidth systems in the next few years.

The text is based on a paper presented by the author at the Convegno Internazionale della Comunicazioni in Genoa on 10 October 1963, and is reproduced here by permission of the President of the Convention.

INTRODUCTION

THIS year marks the 21st anniversary of the insertion of the first submarine repeater—a British one—into a working cable. From this humble beginning has sprung a global submarine telephone-cable network with an investment of around £200M. Although there was a most urgent need for international circuits, submarine systems would not have been acceptable unless they could have demonstrated an economic standard of reliability. This criterion for success has only been realized by adopting standards of design and inspection and conditions of manufacture never before attempted. Confidence in stability and long life can, however, only be established slowly—particularly in respect of active components such as valves. The general pattern of development has therefore been to proceed through extensive laboratory life-tests to shallow-water systems, and thence to the more important deep-sea systems. It is only now, after the laying of over 30,000 nautical miles (n.m.) of cable during the last 9 years, that one can begin to assess with some confidence the reliability obtainable on deep-sea systems and its impact on future designs.

Although there have been interesting submarine contributions from several countries, the outstanding achievements in this field are due almost entirely to intensive British and American efforts.

EARLY SHALLOW-WATER SYSTEMS

On the evening of 24 June 1943, in "half a gale," a submarine repeater was carefully lowered 35 fathoms to the sea bottom. It had been inserted by H.M.T.S. *Iris* about midway between Cemaes Bay (Anglesey) and Port Erin (Isle of Man) in a 1942 paragutta-insulated coaxial cable. According to the official report "electrical end-to-end tests were continued for half an hour after the laying operations were complete and no faults occurred."

This was the first submarine repeater¹ in the world to be connected into a working cable, and the British Post Office has every right to be proud of this historic "first." The small team engaged on this operation little realized its significance or the era which they were inaugurating.

The original cable was already carrying two 12-channel groups in each direction in the band 12–228 kc/s. When the repeater was inserted it passed this band unamplified but provided an additional amplified band 276–472 kc/s in one direction. The circuit capacity was

thus doubled but, be it noted, if the amplifier path failed the original traffic arrangements could be restored.

The factor which delayed the earlier development of submarine repeaters was undoubtedly the unreliability of valves. Only commercial radio-type valves were available and these had a relatively short and unpredictable life. By care in selection it was hoped that the valves in this repeater would give an average life of about 2 years. The life of the amplifier was, however, designed to be greatly extended, at the expense of some complexity, by arranging that from one terminal station any one of three valves could be switched into each position of the 3-stage amplifier.

Unfortunately, it has to be recorded that this first repeater failed after 5 months due to a quite unexpected cause—a punctured mica-foil filter capacitor. The repeater was recovered and replaced by a spare which then operated for seven years before failing, due, this time, to a silver-mica capacitor. These were first lessons in preparing those working on submarine projects to expect the unexpected. Progress, however, was not disheartened by this early failure, which served a useful purpose in emphasizing the essential need for highly reliable components. Fig. 1 shows the spare

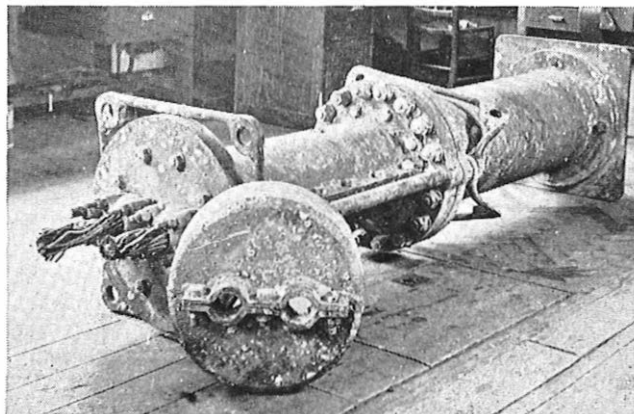

The repeater shown was recovered after 7 years' immersion
FIG. 1—BRITISH SHALLOW-WATER SUBMARINE REPEATER (1943–1953 TYPE)

repeater after recovery; the type of construction is typical of all early shallow-water repeaters.

On 29 June 1946 the traffic capacity of the 196 n.m. Lowestoft–Borkum (Germany) polythene-insulated cable was increased to five speech circuits by the insertion of a repeater² with 2-stage amplification in one direction. As it was only intended to be a temporary scheme no arrangements were made for switching-in spare valves. This repeater, however, is still working after 18 years with no measurable sign of deterioration, and it now holds the world record for the longest working service. It is interesting to note that even then commercial valve-manufacturing techniques could on occasion, and no doubt fortuitously, produce a long valve life.

†Post Office Research Station.

Spurred on by the urgent need for more circuits to the Continent and with a growing confidence in valve performance, the Post Office embarked on the design of a multi-repeater system for up to 10 repeaters capable of providing 60 circuits. Expected valve life had now risen to about 5 years, and on this basis it appeared more economic, for cross-channel systems, to install repeaters than to lay very-large-diameter non-repeated cables.

Amplification now had to be introduced into both directions of transmission and so was evolved the basic repeater circuit (Fig. 2) which has since been employed on all single-cable schemes. A new problem was, however, encountered—that of accurately locating any type of traffic-interfering fault. Even today this presents the system designer with a major challenge that has grown in importance with the large numbers of repeaters

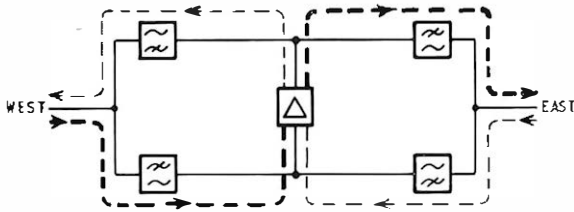

FIG. 2—BASIC CIRCUIT OF 2-WAY SINGLE-CABLE REPEATER

now involved and with the heavy cost of deep-sea repair operations. The supervisory equipment required in each repeater, together with the bandwidth absorbed by these fault-locating facilities, can prove very expensive. There is still today no wholly satisfactory solution. For the 60-circuit system a very elegant method³ was proposed by the Post Office, based on the principle that a

transmitted pulse could produce at each repeater a distortion pulse which would be returned in the other band to the transmitter. From the relative amplitudes of these pulses, received in time sequence, a gain or distortion fault could be located. This method can still provide valuable information on modern systems, and it has the merit of requiring no additional equipment within the repeater.

A number of these shallow-water systems was laid from 1950 onwards and they performed as expected.

In 1950 the Americans laid their first submarine-cable system⁴ between Key West and Havana (120 n.m.) in a maximum depth of 900 fathoms. The capacity was 36 circuits, and one cable with 4 repeaters was required for each direction of transmission. Each repeater consisted of a long flexible structure little larger in diameter than the cable, and their laying and recovery involved no exceptional difficulties. Great attention had been paid to the reliability of the components, and construction was carried out under "clean" conditions. Also in this year the Western Union inserted the first submarine telegraph repeater off Newfoundland—the normal pattern of telegraphy before telephony had been reversed.

DEEP-SEA SYSTEM DEVELOPMENT

It was by now becoming evident that it would soon be possible to accept the challenge of a transatlantic cable—a venture which had even been considered before the repeater era—and serious studies were initiated independently on both sides of the Atlantic. The British wished to pursue their single-cable technique which involved rigid repeaters, and it was considered that such repeaters could be developed to meet acceptable reliability requirements, i.e. not more than 10 per cent repeater failures in 20 years. Long-life valves deve-

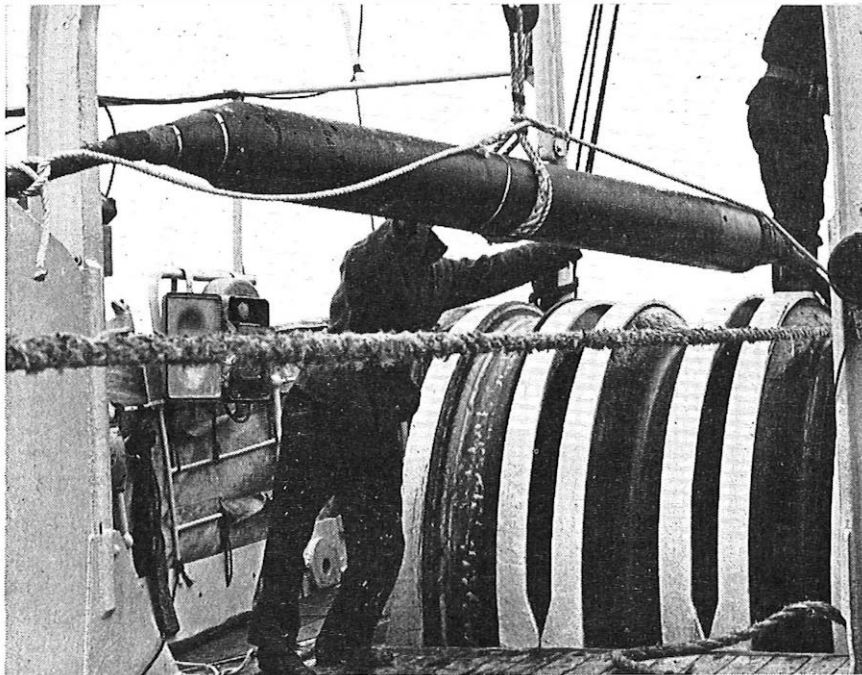

FIG. 3—TYPICAL BRITISH REPEATER (TYPE EMPLOYED FROM 1954 ONWARDS)

loped by the Post Office were soon expected to be available, and, in addition, it was planned to provide further security by using in each repeater two mutually-independent amplifying paths in parallel controlled by one feedback network. Existing fault-locating techniques, however, were inadequate in that they could not determine the source of a noise fault on the system. Such a facility was considered to be essential on a transatlantic system. The development of housings and glands to withstand deep-sea pressures (5 ton/in²) was proceeding satisfactorily. Fig. 3 shows a complete repeater, which has changed little in external appearance during the last decade. This type has been laid both in shallow and in very deep water, and also buried on land.

A very serious problem was encountered when it was found to be an extremely difficult if not an impossible operation to recover the rigid $\frac{1}{2}$ -ton repeaters in very deep water. The torque set up in the spiral armour layer of the cable under tension twisted or developed kinks which damaged or broke the cable near the repeater on the sea bottom. What proved to be the breakthrough occurred in 1951 when the Post Office proposed a revolutionary new design^{5,6} of deep-sea cable which not only completely overcame this difficulty but offered many additional important advantages. This cable was named the Lightweight cable, since in water it weighed only one-fifth that of a comparable conventional cable. It was obvious, however, that to establish complete confidence in this new cable would necessitate several years' work.

During 1952-3 there were Anglo-American-Canadian discussions on proposals for a transatlantic system, and, as a result, it was agreed that such a project should be undertaken using the American system. This cable (TAT-1)⁷ was laid during 1955-6 between Newfoundland and Scotland, and was successfully brought into service carrying 36 4 kc/s telephone circuits. This was an epic only rivalled by the laying of the first transatlantic telegraph cable nearly 100 years earlier. During the next 3 years several more systems of this type were installed, perhaps the more important being San Francisco-Hawaii (2,100 n.m.) and TAT-2 from Newfoundland to France in 1959.

Meanwhile British development based on the Lightweight cable had been progressing towards a higher-circuit-capacity system (80 circuits), and in 1957 the provision of an Anglo-Canadian cable (CANTAT) was authorized by the Governments concerned; this system was envisaged as the first step in a world-encircling British Commonwealth submarine telephone-cable network.⁸ CANTAT was the first deep-sea single-cable system, and it was successfully laid and opened to traffic in 1961.⁹ In this and later systems the capacity is quoted in 3 kc/s spaced circuits.

In 1962 an urgent New Jersey (U.S.A.)-Bermuda system was laid for "man-in-orbit" requirements and a start was made on the Commonwealth Pacific cable system (COMPAC). This is an 8,700 n.m. trans-Pacific network linking Australia to Canada via New Zealand, Fiji and Hawaii. It was opened to traffic on 2 December 1963¹⁰ and provides United Kingdom-Australian circuits wholly over submarine cable (11,000 n.m.) except for a radio-relay link across Canada.

This year also marked the introduction of a new American design of system, which was laid between New Jersey, U.S.A., and England (TAT-3).¹¹ The

system is rather similar to the British design in that it uses repeaters in rigid housings with a single cable of lightweight-type construction, but it is of still larger capacity (128 circuits). It has a cable length of about 3,500 n.m., which by a margin of only a few miles establishes it as the longest continuous cable link in the world.

It is interesting to note certain differences between these two modern systems in their equalizing and laying methods. Gain misalignments during laying degrade the efficiency of the system and must, therefore, be kept to a minimum. The Americans set out to accomplish this by specifying their components, repeaters and cable so precisely that only simple root-frequency and straight-line-frequency equalizer networks, selected and switched in during laying, are necessary on even the longest system. Temperature, pressure and laying effects have to be known accurately. The British approach is to be satisfied with less stringent electrical characteristics for repeaters and cable, and to correct any misalignments that may build up after every 12 repeater sections by completely flexible equalizer networks¹² inserted during, and without stopping, the laying operation. This method has now worked excellently over more than 10,000 route miles.

Laying techniques also differ. The new American cable ship *Long Lines*, which is at present the largest in the world, is equipped with a massive 80-ton linear-type laying engine which allows cable and repeaters to be fed in-line into the sea without slowing the ship. The British have for some years used a simple V-sheave gear which is bypassed by the repeaters. This has minor disadvantages, however, in that the ship has to be slowed for each repeater overboarding and the cable suffers more bending. American practice is to try to lay the minimum cable slack that will just cover the sea-bottom irregularities. This may be as low as 1 per cent over much of the ocean bottom, whereas the British consider there are justifications for a more generous allowance of 4-6 per cent. The use of parachutes¹³ to slow up the descent rate of repeaters was initiated on CANTAT and has since been used successfully on all British and American systems.

Although attention has been focused on these major developments, reference must not be omitted to the interesting French systems laid in the Mediterranean, and to the German systems installed between Iceland-Greenland-Newfoundland (ICECAN) and more recently in the Caribbean.

FUTURE DEVELOPMENTS

The global cable network will be greatly extended (Fig. 4) during the next 3 years by the American and British systems, but developments are in hand on both sides of the Atlantic for considerably greater bandwidth systems. The pattern of such developments will depend not only on traffic requirements and economics but on the performance and experience accumulated on existing cables.

Reliability is of paramount importance. In this respect, on all transoceanic systems, now involving over 1,000 repeaters, traffic has not been interrupted by a repeater fault. This is a great achievement even though virtually no expense was spared in the design, manufacture and testing of the repeaters. British valves¹⁴ since 1956 have now completed 50 million valve-hours in service without a fault, and the American valve achieve-

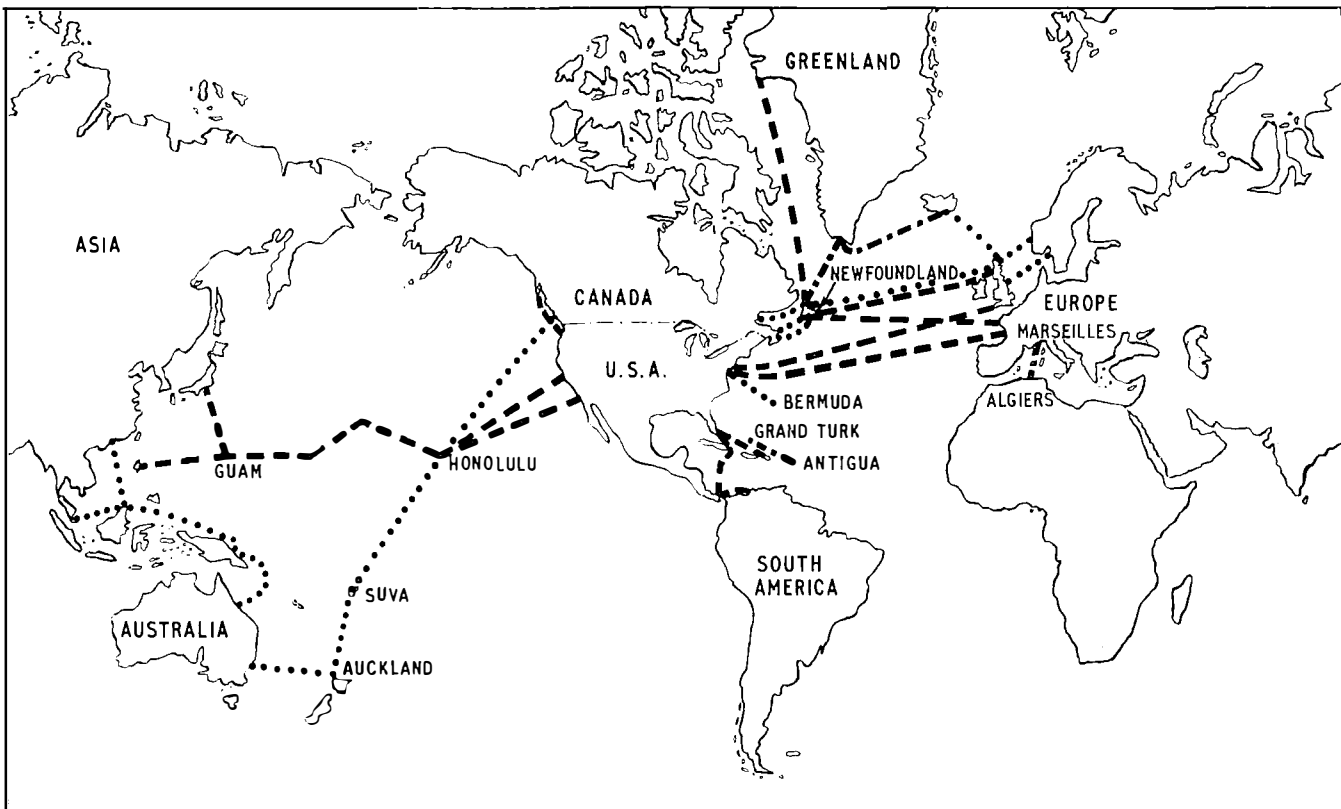

FIG. 4—MAJOR SUBMARINE TELEPHONE-CABLE ROUTES (1963)

ment is equally good. These figures represent a remarkable performance, which has only been attained by an intensive study over many years with the objective of eliminating the many factors inhibiting long valve life. It is also interesting to note that in British-laid repeaters there has been no occasion to doubt any one of the million soft-soldered joints. There has also been no deep-sea cable fault either in armoured or Lightweight cable. However, these telephone cables, like their telegraph predecessors, have unfortunately but not unexpectedly proved vulnerable to trawler activity in depths of less than 350 fathoms: on all the North Atlantic cables since 1959 there have been about 30 such faults. Burying the cable in the sea bottom appears to offer the only solution and experiments for this purpose are proceeding.

Circuit costs have been reduced by replacing 4 kc/s equipment by highly efficient 3 kc/s spaced circuits¹⁵ and by installing American T.A.S.I. (Time Assignment Speech Interpolation) equipment¹⁶ at the terminals. The latter nearly doubles the number of telephone circuits available. Circuit cost also diminishes rapidly as the bandwidth of a type of system is increased. Making certain general assumptions it appears that circuit cost varies inversely as (bandwidth)^{0.75}. The estimated cost of provision of the 8,700 n.m. COMPAC system is £26M complete with buildings and terminal equipment; this represents a cost of about £38 per circuit-mile. For a 1,300 circuit system (10 Mc/s maximum frequency) this figure would be expected to decrease to about £5 per circuit-mile. In all cases telephone circuits of very

high quality (a noise objective of 1 pW/km) have been requested. Each 1 db improvement in noise represents about 1 per cent in circuit cost.

There is, therefore, every incentive to increase bandwidth, and, provided reliability standards can be maintained, experience indicates that the increased hazard of more closely spaced repeaters can be accepted. The phenomenal stability of the Lightweight cable on CAN-TAT, which had less than 0.01 per cent change in attenuation in the first year (Fig. 5), suggests that deep-sea cable losses of 20,000 db should remain adequately stable with time without the necessity for automatic or shore-controlled equalization. Repeater aging could in fact prove to be a predominating factor. Basically, therefore there are no apparent reasons why the present type of system should not be developed for much greater bandwidths. Technical problems, however, will certainly arise in respect of repeaters and cable.

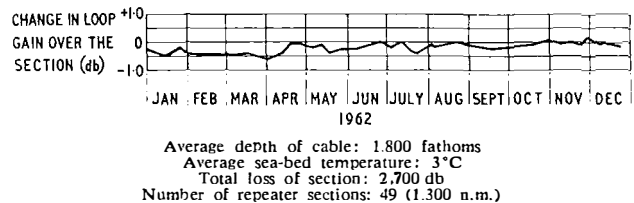

FIG. 5—VARIATION OF GAIN OF LIGHTWEIGHT-CABLE SECTION OF CANTAT CABLE DURING FIRST YEAR OF SERVICE

Long-life valves for repeaters are approaching their limiting frequency and it will be necessary to turn to

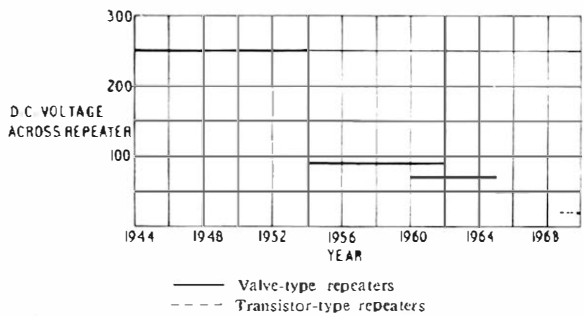

FIG. 6—D.C. VOLTAGE REQUIREMENTS OF BRITISH REPEATERS

transistors for much higher frequency bands. Available reliability data indicate that these should be at least as satisfactory as valves, but, unfortunately, it does not appear to be practicable to connect two amplifiers in parallel. The d.c. repeater voltage requirement (Fig. 6) will be much less than with valves. Protection of transistors against high-voltage surges caused by cable faults will require even more careful attention than for protection of valve repeaters. Precision gain and loop-feedback measuring equipment has also yet to be developed for these higher frequencies.

Conventional armoured cables are now obsolescent for deep-sea systems, and economic considerations will dictate the use of larger-diameter Lightweight cables, i.e. the present diameter of 1 in. may increase to 1.5–2.0 in. The manufacture of such cables should present no difficulty, but control of the loss-angle of the core insulation will assume greater importance. Bending and handling operations will also be more difficult and the stowage-capacity of a cable ship will be considerably reduced.

Although modern practice favours a single-cable scheme there are circumstances in which a case could be made for a reversion to a twin-cable scheme. For example, such a system with a maximum frequency of 10 Mc/s would give a clear bandwidth of over 9 Mc/s in each direction, with a handling capacity of 3,000 circuits. Alternatively, the bandwidth could be employed for combined telephone circuits and television, the band for the latter being located at the high-frequency end of the spectrum. The correction of delay distortion over the television band would be easier than on a single-cable system.

A specific development now in hand by the British Post Office is the engineering of a 360-circuit system (3 Mc/s) using a very high slope (23 mA/V) long-life valve, which could be ready for laying in 1966. Development has also started on a nominal 1,300-circuit (10 Mc/s) design using transistor amplifiers, which, if required, could be operational by 1969–70. It is understood that the Americans are now following up their 128-circuit system (TAT-3) by engineering a 720-circuit (6 Mc/s) system with transistors to be available about 1966. Technically it appears to be quite practicable for 2,000–3,000-circuit systems to make an appearance in the next decade.

Although the emphasis has been on transoceanic systems interesting progress continues in providing for traffic growth from the United Kingdom to Europe. This year 120-circuit (1 Mc/s) valve-type systems are to be laid to Denmark, Holland and Germany. Transistors will also be employed for the first time in two 420-circuit

(4.3 Mc/s) repeaters being developed by a contractor for insertion into a Belgian cable. Further expansion in 1966 will provide 480-circuit (5 Mc/s) transistor-type systems to Holland and Norway (52 repeaters), which should provide useful experience for deep-water projects.

Tremendous efforts on a lavish scale have recently been directed to exploring the capabilities of satellite

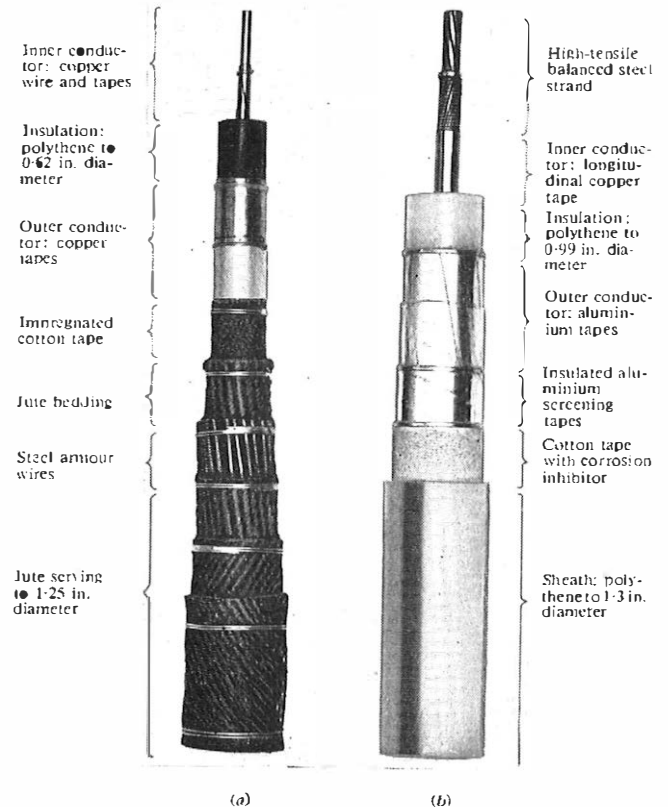

(a) Conventional (Armoured) Cable Used up to 1960
(b) Lightweight (Armourless) Cable Used 1961 Onwards
FIG. 7—COMPARISON OF CONVENTIONAL AND LIGHTWEIGHT DEEP-SEA TELEPHONE CABLES

communication, and the results indicate with little doubt that ultimately, in some form, it will play a major part in global intercourse. The pattern of development of satellite networks has, however, yet to be established, and the reliability, stability and economic features assessed. Submarine cables provide essentially a point-to-point service and, particularly over medium or short routes of high traffic density, it may be a long time before satellites can compete on an economic basis.

References

- ¹HALSEY, R. J., and DUERDOTH, W. T. The First Submerged Repeater. *P.O.E.E.J.*, Vol. 37, p. 33, July 1944.
- ²HALSEY, R. J., and WILLIAMS, H. The Anglo-German Submarine Cable System. *P.O.E.E.J.*, Vol. 40, p. 49, July 1947.
- ³SCOWEN, F. Location of Repeater Faults on Submarine Telephone Cables. *P.O.E.E.J.*, Vol. 54, p. 252, Jan. 1962.
- ⁴New Key West-Havana Telephone Cable. *Bell Laboratory Record*, Apr. 1951, et. seq.
- ⁵BROCKBANK, R. A., and MEYERS, A. L. A New Deep-Sea Coaxial Cable. *P.O.E.E.J.*, Vol. 50, p. 7, Apr. 1957.

⁶Deep-Sea Trials with Lightweight Cable. *P.O.E.E.J.*, Vol. 50, p. 9, Apr. 1957.

⁷Transatlantic Telephone Cable. *P.O.E.E.J.*, Vol. 49, pp. 280-458. Jan. 1957.

⁸Proposed Commonwealth Pacific Telephone Cable System. *P.O.E.E.J.*, Vol. 53, p. 42, Apr. 1960.

⁹The Anglo-Canadian Transatlantic Telephone Cable System (CANTAT). *P.O.E.E.J.*, Vol. 56, pp. 73-104, July 1963.

¹⁰Inauguration of the Commonwealth Pacific Cable (COMPAC). (In this issue of the *P.O.E.E.J.*)

¹¹A Proposed New Cable System Direct to U.S.A.—TAT-3. *P.O.E.E.J.*, Vol. 5, p. 169, Oct. 1960.

¹²SCOWEN, F. The Equalization During Laying of the Anglo-

Swedish Submarine Telephone Cable. *P.O.E.E.J.*, Vol. 54, p. 48, Apr. 1961.

¹³CLARKE, E. F. S. and CHAPMAN, K. J. Cable Laying—By Parachute. *Post Office Telecommunications Journal*, Vol. 14, p. 94, Summer 1962.

¹⁴HOLMES, M. F., and REYNOLDS, F. H. New Valves for Deep-Water Submerged Telephone-Repeaters. *P.O.E.E.J.*, Vol. 53, p. 98, July 1960.

¹⁵LAW, H. B., REYNOLDS, J., and SIMPSON, W. G. Channel Equipment Design for Economy of Bandwidth. *P.O.E.E.J.*, Vol. 53, p. 112, July 1960.

¹⁶CLINCH, C. E. E. Time Assignment Speech Interpolation (T.A.S.I.). *P.O.E.E.J.*, Vol. 53, p. 197, Oct. 1960.

A New Wall Telephone—Telephone No. 711

F. J. HARVEY, A.M. Brit. I.R.E.†

U.D.C. 621.395:721.3

A new wall telephone has been developed that incorporates many of the features and components of the 700-type range of table instruments. The new telephone provides all the facilities offered by the table instruments, and the number of different add-on units necessary to provide certain of these facilities has been kept to a minimum.

INTRODUCTION

THE two table telephones described in previous articles^{1, 2} meet subscribers' requirements for direct-exchange-line telephones without push-buttons and for the many different extension-plan telephones with up

to four push-buttons. Extension Plans 105 and 107 use a separate plinth³ fitted beneath either of the table telephones. The new wall telephone, Telephone No. 711 (Fig. 1), is the wall equivalent of both these telephones and provides all the facilities offered by the two table instruments. Just as the two table instruments are the 700-type equivalent of 13 different 300-type telephones, so this new wall telephone is the 700-type equivalent of three different 300-type telephones. A new wall plinth is being developed to provide Plan-105 and Plan-107 facilities with the wall telephone.

EXTERNAL DESIGN

The new wall telephone uses the same design of base as the conventionally-wired version of the 700-type table telephone and the outside base dimensions of the cover are, therefore, similar to those of the 700-type table instruments. The overall shape has a slimmer and more modern appearance than that of the 300-type wall telephones. The standard handset (Handset No. 3), as used on the 700-type table instruments, is normally placed horizontally in the cradle rest across the top of



FIG. 1—TELEPHONE NO. 711



FIG. 2—"OFF-HOOK" REST POSITION FOR HANDSET

†Subscribers' Apparatus and Miscellaneous Services Branch, E.-in.-C.'s Office.

the instrument to operate the two gravity-switch plungers. The two tines of the cradle rest have been so shaped that the handset may be hung vertically from either side without the gravity-switch plungers being operated (Fig. 2), thus providing a temporary "off-hook" rest position for the handset.

In the front face of the case, just below the cradle rest, is a rectangular aperture to allow for the provision of from one to four push-buttons; this aperture is normally closed by a moulded blank. Below this is the dial, which is fixed to the chassis and protrudes through a large circular hole in the case. Around the dial is an enlarged number ring which is fitted to the case.

THE COVER

The cover is of polymethyl methacrylate, i.e. the same material as is used for the mouldings of the table telephones. There are no moulded-in inserts. The cover is fixed to the chassis by one screw, which passes through a hole in the bottom face into the cord-anchor bracket, and by two prongs on the gravity-switch bracket, which engage in the gravity-switch plunger holes. For instruments fitted with dials the enlarged number ring is the standard item, but for instruments required in manual-exchange areas a new dummy dial has been designed having a simplified method of attachment and with direct access to the centre label.

THE CHASSIS

As already mentioned, the telephone has been developed to utilize the same design of base as the conventionally-wired 700-type table telephone, and the same base moulding is used (Fig. 3). The telephone is not fitted with a line cord or terminal block, connexion being made direct by cable via a cable entry in the base. The circuit wiring, induction coil, capacitor, bell mechanism and gongs are also the same as those used in the table instruments, but the main bracket has been completely redesigned. This bracket extends for two-thirds of the length of the base and is attached both directly to the base and by the bell-gong fixing screws. It supports the dial mounting and carries the gravity-switch levers and spring-sets, and a series of holes are provided for the addition of various add-on units.

The plungers of the gravity switch pass through the holes in the cover and their accurate alignment is ensured by the small projections of the bracket that are used to fix the cover in position. The gravity-switch is mounted half way up the gravity-switch bracket and is operated by a 2-piece lever mechanism that converts the vertical movement of the plungers to an almost horizontal movement of the spring-set operating bar. When the cover is removed the gravity-switch may be locked in the handset "on" position by a spring blade which hooks over the upper gravity-switch lever. When the cover is replaced this latch is released as the handset is placed in position. The spring-set has twin palladium contacts and is covered with a clip-on dust cover. The two plungers are integral with a bar which has projections to operate the latch-plate mechanism on the multi-push-button unit.

The redesign of the main bracket has placed the dial above the regulator jack-points in the base, and it has been necessary to use a regulator board which is wider and shorter than the one used for the table instruments.

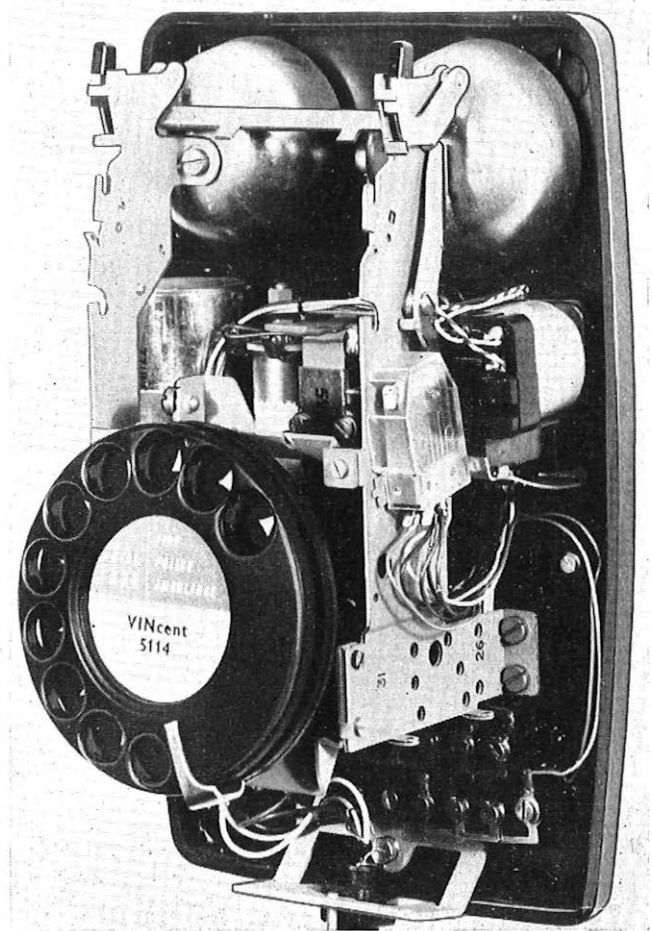

FIG. 3—INTERIOR OF INSTRUMENT SHOWING MAIN BRACKET

No change has been made either to the circuit or the other components.

ADD-ON UNITS

The telephone can provide all the facilities offered by the two types of table instruments (Telephones No. 706 and No. 710), but for some of these facilities various add-on units are required. All such units that need to be electrically connected to the telephone are provided with flexible wiring and spade tags. Some of the additional units are the same as those used for the table instruments; this simplifies both installation and maintenance, and keeps to a minimum the number of add-on parts that have to be stocked separately.

Push-Button Units

Single-Push-Button Unit. Fig. 4 shows the single-push-button unit, which consists of a Switch No. 5A-3 and a special bracket. The switch may be made either locking or non-locking by the use of the appropriate type of push-button; a non-locking button is shown.

Multi-Push-Button Unit. The multi-push-button unit performs the same function as the latch-plate mechanism in the 4-push-button table telephone.² A latch plate with adjustable latches is used to give the various key operations, and the same range of push-button spring-sets introduced for the 4-push-button table tele-

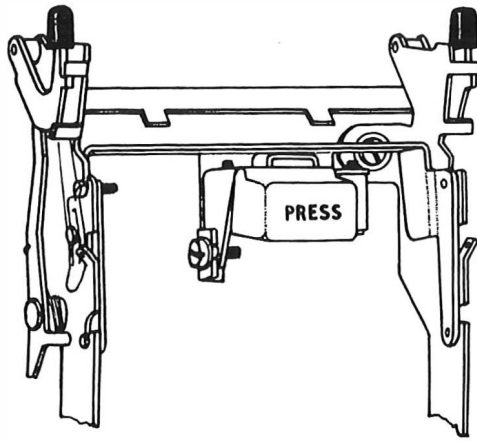

FIG. 4—SINGLE-PUSH-BUTTON UNIT

phone can be fitted. The unit, which is shown in Fig. 5, is held in the gravity-switch bracket by means of two locating pins engaging in slots and by two coil springs. The springs hold the unit firmly in position, but when push-buttons are fitted they facilitate the removal of the cover by permitting a slight longitudinal movement of the unit.

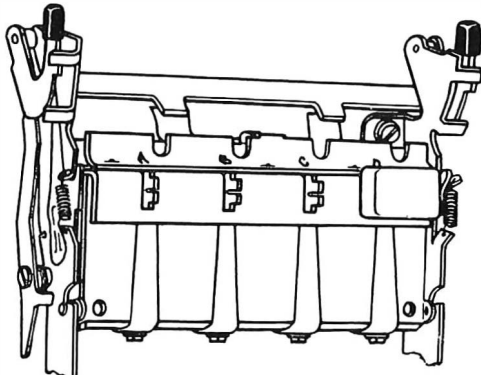

FIG. 5—MULTI-PUSH-BUTTON UNIT

Push-buttons

A range of push-buttons marked with various legends similar to those for the two table telephones are available. The push-button for the Switch No. 5A-3 uses the same methods for obtaining the non-locking and locking features as was used on the earlier Switches No. 5A-1 and No. 5A-2.¹ This push-button only occupies about one-third of the slot in the cover and a pair of dummies are fitted, one on either side of the button, to fill the slot.

The push-buttons for the multi-push-button unit are pushed on to the slotted ends of the spring-set operating bars. As these four bars project through the slot in the case it is not possible to fit dummies if less than the maximum of four press-buttons is required. Therefore, to ensure a neat arrangement, there are two sizes of button, one being twice the length of the other; thus, two large buttons would be used to fill the slot in the cover when only two press-buttons are required. This larger button engages with two operating bars so that it is possible for two spring-sets to be operated at the same time.

Gravity-Switch Contacts

The essential gravity-switch contacts are fitted on one side of the main bracket and an additional spring-set may be fitted to the opposite side if required.

Local-Battery Adapter

The local-battery adapter consists of a choke coil and gravity-switch spring-set; it is fitted when the telephone is to be used with local-battery exchange systems.

D. C. Bell

The trembler bell that is being designed for the table telephones will also fit in the new wall telephone.

Buzzer

A d.c. buzzer can be fitted if the wall telephone is used as the extension instrument of a Plan 105 or Plan 107.

Lamp Signals

Two small signal lamps can be fitted. These are supported in rubber mounts inserted in the same cross-bar that supports the top of the dial mounting. When signal lamps are fitted the cover must be exchanged for one fitted with two lenses.

Terminal Strips

The 6-way and 18-way terminal strips provided for the 4-push-button table telephone can both be fitted, making a possible 30 extra terminations if required.

METHOD OF MOUNTING

Each wall telephone is supplied with a special T-bracket and screw. The bracket is first fixed to the wall. Only two rubber feet are fitted in the telephone base and, after the cover has been removed, the holes for the other two feet are placed over the two hooks of the bracket, the handset-cord grommet is moved to one side, and the telephone is fixed to the bracket by the screw inserted through the hole in the cord-grommet bracket.

CONCLUSION

A new wall telephone has been designed that offers all the standard facilities for direct-exchange-line and extension-plan working. It will also meet most of the demands for special and non-standard arrangements.

ACKNOWLEDGEMENTS

The new wall telephone has been developed by the General Electric Co., Ltd., for the Post Office under the British Telephone Technical Development Committee procedure.

References

- ¹SPENCER, H. J. C., and WILSON, F. A. The New 700-Type Table Telephone—Telephone No. 706. *P.O.E.E.J.*, Vol. 52, p. 1, Apr. 1959.
- ²SPENCER, H. J. C. A Table Telephone with Four Push-Button Keys—Telephone No. 710. *P.O.E.E.J.*, Vol. 53, p. 190, Oct. 1960.
- ³AKESTER, K. M. A Switching Unit for Use with 700-Type Telephones—Plan Set N 625. *P.O.E.E.J.*, Vol. 53, p. 242, Jan. 1961.

The Electrical Properties of High-Frequency Transistors

H. G. BASSETT, B.Sc.(Eng.), A.M.I.E.E. and P. E. GREENAWAY, B.Sc.†

U.D.C. 621.382.333.029.5

The use of a diffusion as a technique for making transistors has complicated their circuit behaviour, particularly at high frequencies. The graded-base transistor's properties at high frequencies are examined using the charge-control approach for both amplifying and switching operations.

INTRODUCTION

THE application of transistors at high frequencies is made difficult by the complicated behaviour of the transistor as a circuit element; five characteristic frequencies have been defined and they may extend over a frequency range of more than 10 : 1 for a given transistor. In addition, the actual bandwidth obtainable from an amplifying stage is dependent on the source and load impedances as well as on the characteristic frequencies. The advent of diffusion as the dominant technique in transistor fabrication has added to the difficulties by further complicating the circuit behaviour.

These difficulties arise mainly for two reasons. Firstly, the transistor action in a mesa or planar transistor¹ takes place mainly under the periphery of the emitter, and some of the operating currents have to flow through bulk semiconductor material in order to reach the effective region. Distributed resistance and capacitance are thus added to the circuit configuration, and circuit engineers sometimes regard the complete transistor as consisting of an "intrinsic" transistor (representing the site of transistor action) surrounded by an "extrinsic" network of parasitic elements. The second factor is the complexity of the current transport through the base region. Minority carriers are propelled forward from the emitter partly by the impurity grading in the base and partly by their own concentration gradient. Thus the speed of operation is dependent on the rate at which the base charge can be changed, which is clearly affected by the impedance in the base circuit.

The object of this article is to examine, in as simple a manner as possible, the high-frequency properties of graded-base transistors, particularly planar transistors. The idea of charge control has been used to analyse the amplifying and switching operations.

THE TRANSISTOR AS A CHARGE-CONTROLLED DEVICE

In an earlier article² one of the authors described the transistor as a current-operated device. This idea was useful at frequencies below f_{hfe} (where the base-collector current gain has fallen by 3 db) but needs to be abandoned in favour of the charge-control idea³ at higher frequencies. To make things simple, let it be supposed that one can take liberties with the laws of solid-state physics and construct a hypothetical p-n-p transistor having zero collector and emitter cut-off currents (I_{CBO} and I_{CEO}), a uniform base layer in which majority and minority carriers never recombine, and an ideal emitter junction. It is interesting to consider what electrical

properties this transistor would have when operated in the grounded-emitter configuration, as shown in the circuit of Fig. 1.

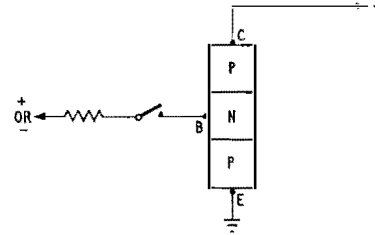

FIG. 1—IDEAL TRANSISTOR IN GROUNDED-EMITTER CIRCUIT

Commencing with no minority carriers in the base layer, and with the switch open, no collector current would flow. If the base were then switched to a negative supply, holes would be injected at the emitter junction and an equal number of electrons would flow in at the base connexion to maintain charge neutrality in the base. If the switch were then opened, electrons would not be able to escape from the base layer at either the emitter or collector junctions, and holes could only escape by being captured at the collector junction. Every hole which escaped in this way would have to be replaced by one injected at the emitter, in order to maintain charge neutrality. Thus, the collector current would flow indefinitely, and the transistor would have infinite current gain for d.c. signals.

Because current flows across the base by diffusion of carriers, the current is proportional to the concentration gradient of the carriers,⁴ and the carriers would ultimately distribute themselves across the base layer in the triangular distributions shown in Fig. 2. The collector

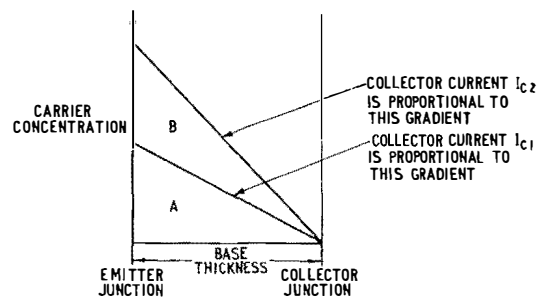

FIG. 2—CARRIER DISTRIBUTION IN THE BASE LAYER OF AN IDEAL TRANSISTOR

current, I_{C1} , is turned on by the charge consisting of holes together with an almost equal number of electrons represented by the area A. The addition of the charge represented by the area B would raise the current to the value I_{C2} (the charge is proportional to the collector current).

A direct consequence of charge control is that the

† Post Office Research Station.

current gain, h_{ie} , falls at the rate of 6 db per octave as the frequency rises. This is because,

$$i_c = k \int i_b dt,$$

where i_c and i_b are the instantaneous collector and base currents. Now, if a sinusoidal signal $I_b \sin \omega t$ is applied, together with suitable d.c. bias currents,

$$i_c = -\frac{k}{\omega} I_b \cos \omega t,$$

and the amplitude of the collector current is inversely proportional to frequency. The appearance of $\cos \omega t$ in the equation indicates a phase shift of 90° at all frequencies, and Fig. 3 shows the constant slope of 6 db

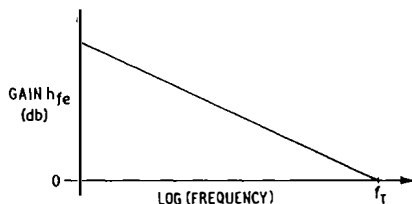

FIG. 3—FREQUENCY RESPONSE OF IDEAL TRANSISTOR

per octave for the gain/frequency characteristic of the postulated ideal transistor; the gain becomes 0 db at the frequency, f_T .

TRANSITION FREQUENCY

The frequency, f_T , at which the straight line in Fig. 3 extrapolates to 0 db is called the transition frequency (or sometimes, rather misleadingly, the gain-bandwidth product) and is in widespread use as a characteristic frequency. At this frequency an appreciable proportion of the base charge is injected and removed before it reaches the collector; Rollett⁶ has shown that the average time taken for carriers to cross the base layer is given by $1/2\pi f_T$. Thus, the value of f_T can be informative to the transistor technologist as well as giving the circuit designer information about the base-collector current gain of the transistor over a wide range of frequencies. The transition frequency, f_T , should not be confused with the parameter, f_{α} , which refers to the emitter-collector current gain.

AN EQUIVALENT CIRCUIT FOR THE IDEAL TRANSISTOR

The behaviour of the ideal transistor referred to above can be represented by the 2-port network shown in Fig. 4.

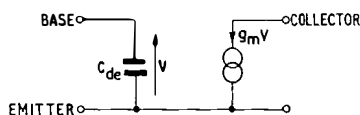

FIG. 4—EQUIVALENT CIRCUIT OF IDEAL TRANSISTOR

The capacitor C_{de} , whose capacitance is known as the emitter diffusion capacitance, approximately represents the storage of charge necessary to produce transistor action, and the collector current is assumed to be generated by a frequency-independent generator operated by the voltage across the capacitor. Capacitor C_{de} must not be imagined as a fixed component, nor has the mutual conductance a fixed value independent of all d.c. bias

currents. In fact, the diffusion capacitance is approximately proportional to the d.c. emitter bias current I_E , and the mutual conductance, in mA/V, is approximately given by $39I_E$, where I_E is in milliamperes. Expressions for g_m and C_{de} are given by Middlebrook⁶ in his parameters y_b and y_i .

It is now possible to consider some of the complications which are added to this simple picture when a practical planar transistor is considered.

ADDITIONAL EFFECTS OCCURRING IN A PRACTICAL TRANSISTOR

Emitter and Collector Depletion Capacitances

All p-n junctions, including the forward-biased emitter junction, have a depletion layer which changes in width as the applied voltage is changed. The variation in width is due to a movement of majority carriers on each side of the junction, and thus the change in voltage causes a current to flow while the depletion layer is changing in width. The emitter junction, therefore, behaves as though it possesses capacitance, and this is known as the depletion capacitance, C_{te} ; the charging current associated with this capacitance takes no part in transistor action but has to be supplied by the input circuit. The value of C_{te} changes more slowly with emitter bias current than does that of C_{de} , so that the shunting effect of C_{te} reduces f_T more at low bias currents than at high. This reduction of f_T can be considerable in high-frequency diffused-base transistors, and can be important in large-signal applications.

The collector depletion capacitance, C_{tc} , forms a shunt path between the collector and base as far as a.c. signals are concerned. When the base is used as the input electrode, therefore, Miller-type feedback occurs, and a simulated capacitance can appear across collector and emitter which is sometimes much larger than C_{tc} . In fast switching applications, C_{tc} may be of great importance because of the charge which it absorbs when the transistor is turned on or off.

For a uniformly graded junction of the planar transistor, as opposed to the step junction of the earlier alloy transistor, C_{tc} is approximately inversely proportional to the cube root of the applied voltage; Middlebrook⁷ gives a more detailed treatment. The locations of capacitors C_{te} and C_{tc} in the equivalent circuit of the transistors are shown in Fig. 5.

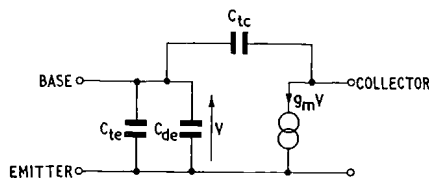

FIG. 5—EQUIVALENT CIRCUIT SHOWING CAPACITORS REPRESENTING DEPLETION CAPACITANCES

The Diffused Base as a Means of Speeding-up Carrier Transport

If the concentration of impurity atoms in the base layer is not uniform, the majority carriers tend to diffuse away from the region of high concentration. The resulting slight departure from charge neutrality produces a "built-in" electrostatic field which tends to drive minority carriers in the direction of decreasing impurity

concentration. Thus, the impurity distribution drives minority carriers across the base layer towards the collector junction. A transistor with such a base layer is known as a "graded-base" or "drift" transistor, and, because of the improved transport of minority carriers, has a higher f_T than a uniform-base transistor of the same geometry. This advantage is partly offset in two ways. Firstly, C_{ic} is more troublesome than in a uniform-base transistor, because the increased impurity concentration just beneath the emitter junction makes the emitter depletion layer thinner. Secondly, at higher collector currents the space charge responsible for the drift field is reduced by the high concentration of carriers in the base layer. Thus, the transistor has a high f_T at moderate current levels, but f_T falls at low collector currents (as explained above) and also at very high current levels. Drift transistors, just as much as uniform-base transistors, are charge-controlled devices, and exhibit a fall of current gain with frequency of approximately 6 db per octave. The phase shift in this slope region is, however, different from the idealized value of 90° ; there may be 20° or more of extra phase shift at the frequency f_T . The triangular distribution of charge across the base layer (shown in Fig. 2) assumes a curved profile because a concentration gradient is no longer the only propelling force for minority carriers.

Variation of Effective Base Width with Change of Collector Voltage

The collector depletion layer in a drift transistor is situated in a region of rather low-impurity concentration, and is, therefore, quite wide at normal collector voltages. When the collector voltage becomes low, however, the depletion layer shrinks considerably, so that the effective base width increases sharply.⁸ As seen, f_T is related to the average transit time across the base layer, and so a rapid fall of f_T occurs at low collector voltages (typically below 2 or 3 volts). This effect is important in switching applications, as will be seen later.

It has been shown above how f_T is reduced at low values of collector voltage and current, and also at high values of collector current; these effects are often shown by plotting contours of constant f_T against collector voltage and current, as shown in Fig. 6 which is typical of a planar transistor.

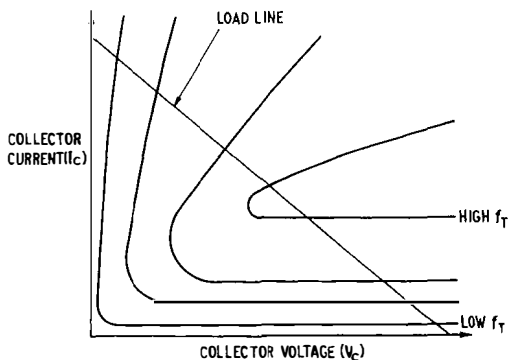

FIG. 6—CONTOURS OF CONSTANT f_T PLOTTED AGAINST V_C AND I_C .

Clearly a constant value of f_T must not be assumed when considering large-signal applications. A typical load line, such as that shown in Fig. 6, passes through a

region of high τ at its centre and reduced values of f_T at its extremities. The extremities are important in switching applications, and one requirement for good switching transistors is that f_T should fall as little as possible at low values of collector voltage and current.

Low-Frequency Behaviour due to Finite Carrier Lifetime and Imperfect Operation of Emitter

A practical emitter junction is imperfect in the sense that some of the emitter current does not produce minority carriers in the base layer. The lifetime of minority carriers in the base layer is also finite in practice. Both these effects cause the base charge to diminish with time if the base is open-circuited, as shown in Fig. 1. To keep a practical transistor turned on, it is necessary to supply enough base current to make good the loss of base charge, so that the transistor has a finite current gain at d.c. and at low frequencies. Fig. 7 shows the frequency

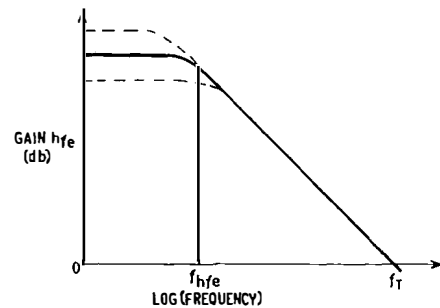

FIG. 7—FREQUENCY RESPONSE OF A PRACTICAL TRANSISTOR

response of such a transistor, and it is seen that a new characteristic frequency, f_{hfe} , (also sometimes known as f_B) is introduced: it is the frequency at which the low-frequency value of h_{fe} has fallen by 3 db (f_{hfe} is not a very important parameter in practice; it tells one little about the cut-off frequency of a common-emitter stage).

The low-frequency value of h_{fe} will depend on the emitter efficiency and minority-carrier lifetime, and the dashed lines show the effect of changing these properties. The frequency f_{hfe} is related to the minority-carrier lifetime, τ ; it is approximately $1/2\pi\tau$.⁹ Thus the low-frequency performance of a practical transistor, below the frequency f_{hfe} , arises because of practical limitations in the emitter and in the base material, which make the transistor appear to be a current-operated device, and above the frequency f_{hfe} , the transistor must be treated as a charge-operated device. The low-frequency behaviour can be incorporated in the equivalent circuit of Fig. 5 by adding a resistance in shunt with the two

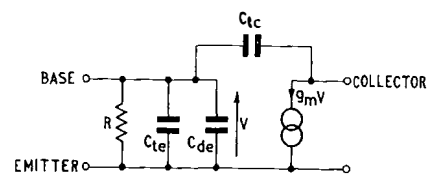

FIG. 8—EQUIVALENT CIRCUIT INCORPORATING LOW-FREQUENCY BEHAVIOUR

emitter capacitances, as shown in Fig. 8. The value of R is approximately $25h_{fe}/I_E$, where I_E is in milliamperes.⁵

THE EXTRINSIC TRANSISTOR

The circuit shown in Fig. 8 is an approximate representation of the behaviour of the site of transistor action. In order to reach this region, however, the emitter, collector, and base currents must travel through the leads and through semiconductor material, and parasitic circuit elements are unavoidably added to the circuit representing the intrinsic transistor. Of the three connexions, that to the emitter is the least complicated because it is metallic almost up to the emitter junction. The emitter connexion, therefore, shows a lumped capacitance at the seal where the lead enters the metal can, and some inductance due to the wires inside and outside the can (the inductance inside the can is usually negligible in practice). In mesa and planar transistors, the collector current has to flow through the silicon wafer in order to reach the collector junction, and in non-epitaxial transistors appreciable collector series resistance appears. When the transistor is soldered direct to the header, the only other parasitic elements added is capacitance from the outside of the can to its environment, and capacitances across the emitter and base seals. The base connexion is by far the most intractable of the three, because the base current must flow through the very thin base layer, flanked on one side by the collector depletion layer, to reach the intrinsic transistor. Thus, in all practical planar transistors, the base connexion includes a non-uniform RC transmission line, as shown in Fig. 9 which summarizes the extrinsic part of a tran-

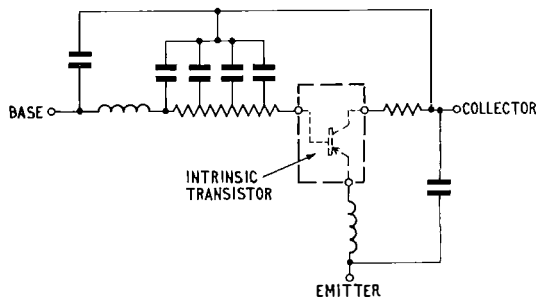

FIG. 9—EQUIVALENT CIRCUIT OF EXTRINSIC TRANSISTOR (COLLECTOR CONNECTED DIRECTLY TO CASE)

sistor. The base lead also adds lumped capacitance at the seal, and a small amount of inductance.

The extrinsic transistor has a significant effect on the performance of the transistor at high frequencies, but it is difficult to study the effects in detail because the effects of the extrinsic transistor cannot be isolated by tests made at the transistor terminals.

THE SMALL-SIGNAL CHARACTERIZATION OF HIGH-FREQUENCY TRANSISTORS

There are two ways in which the small-signal properties of a transistor may be presented to the circuit designer. Firstly, the transistor may be regarded as a "black box" and the 2-port parameters measured at all the frequencies of interest. Six possible sets of parameters exist; they represent six different ways of presenting the same information, and the parameters in any one system can readily be converted from that system to another. Fig. 10 illustrates the y -parameters, which are now tending to displace the more familiar h -parameters.

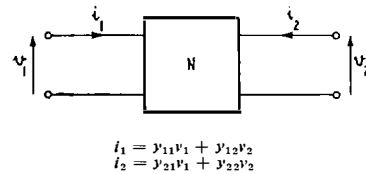

FIG. 10—ILLUSTRATING THE y -PARAMETERS OF A NETWORK

Secondly, an attempt may be made to find an equivalent circuit which represents as closely as possible the electrical behaviour of the transistor. The equivalent circuit represents the transistor more compactly than does a table of y -parameters extending over a range of frequencies, and is usually preferable if it can be found. Thus, the equivalent-circuit approach was almost completely successful in dealing with thermionic valves and was almost invariably used. The alloy transistor was also treated moderately successfully by the equivalent-circuit technique, but a detailed circuit worked out by Price and Hyde¹⁰ had no fewer than 10 extrinsic elements. Mesa and planar transistors have so far proved so difficult to characterize by equivalent circuits that the black-box approach is being widely adopted. By using an electronic computer, quite complicated circuits containing black-box devices can be readily analysed, but progress in characterization by equivalent circuit would still be helpful in circuit synthesis. This progress could come about in two ways: either by the use of more powerful mathematical or measuring techniques, or by further development of semiconductor devices in the direction of simplifying their electrical behaviour.

THE CHARACTERIZATION OF SWITCHING TRANSISTORS

As a switch, the transistor is usually used in the common-emitter circuit of Fig. 11(a) in which the base

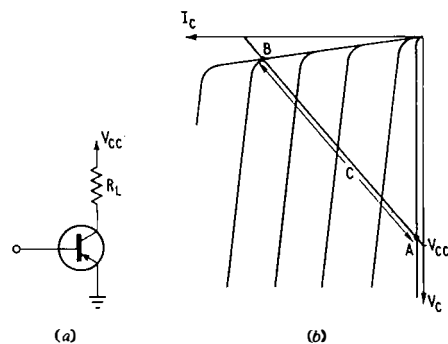

FIG. 11—BASIC SWITCHING CIRCUIT AND ITS OPERATING CONDITIONS

is the control electrode. In this type of circuit, the transistor may be in one of three states shown in Fig. 11(b), which is a diagram of the collector characteristics and includes the load line corresponding to R_L . Voltages and currents proper to a p-n-p transistor will be used in the following treatment because they simplify the description. The first of the three states, represented by point A in Fig. 11(b), is the "cut-off" state in which the base is held positive and the collector current, base current and emitter current are all zero (neglecting I_{CBO} and I_{CEO}); this is referred to as the "off" state. The second state is known as "saturation" and is shown by point B in Fig. 11(b). The base is held negative, the collector voltage is small, the collector current is limited by the

load resistor R_L , and the base current is greater than that required to sustain the collector current; this is referred to as the "on" condition. The third state is the active region, labelled C in the diagram, through which the transistor conditions pass during switching.

The charge-control approach is particularly useful in considering the switching behaviour of transistors because the switching time is mainly determined by the speed with which the charge stored in the base of the transistor can be supplied or withdrawn. In a simplified treatment of switching, it is assumed that there are three main regions where charge can be stored: in the base, in the collector depletion layer, and in the emitter depletion layer. The stored charge in the base consists of two parts; one of these, Q_B , is approximately proportional to collector current and was described above under "The Transistor as a Charge-Controlled Device." The other, Q_{BS} , which is only present when the transistor is in the saturated state, depends on the degree of saturation, i.e. the amount by which the base current exceeds that necessary to sustain the collector current. The depletion-layer charges, Q_C at the collector and Q_E at the emitter, both depend on the widths of the depletion layers and, hence, to the voltages across the appropriate junctions. To show how these charges enter into the switching process, the operations of switching on and switching off a p-n-p transistor will be described.

When the transistor is in the off condition (point A in Fig. 11(b)), the emitter-base junction is reverse-biased by the base being held at a positive potential, V_B , which determines the width of the emitter depletion layer. Similarly, the width of the collector depletion layer is determined by the reverse voltage, $V_{CC} + V_B$, between collector and base, and a charge designated Q_C is stored in the depletion layer. The charge Q_B in the base region is zero. To switch the transistor on, the base lead is connected to a negative supply, causing electrons to flow into the base. Before the emitter can start injecting holes into the base region the emitter depletion layer must be reduced in width, necessitating the removal of a charge Q_E via the base connexion. When this charge has been removed, the emitter junction has become forward biased; holes are injected into the base and move by diffusion and drift towards the collector. On arriving at the edge of the collector depletion layer the holes come under the influence of the relatively strong field existing across the depletion layer and drift rapidly into the collector region, giving rise to collector current. Thus, there is a delay between the application of the switching signal to the base and the start of collector current, this delay being due to the time taken for the removal of the charge Q_E and for the holes to move across the base. As the number of holes in the base increases, an equal number of electrons must flow in via the base connexion to maintain charge neutrality; this represents the charge Q_B which has an approximately triangular distribution across the base width as described earlier in this article. As Q_B increases, the collector current increases and the collector-base voltage falls owing to the voltage drop across load R_L ; thus, the collector depletion layer decreases in width and its charge changes accordingly. The current causing this change of charge, Q_C , flows via the base and collector leads and must be supplied by the circuit which is driving the transistor.

If sufficient drive is available at the base, the collector

current continues to rise until the collector-base voltage approaches zero. When this condition is reached, the voltage across the collector depletion layer becomes small and holes reaching the edge of the depletion layer are not swept into the collector as fast as they arrive. The hole concentration at the collector boundary now builds up until the excess base current is balanced by the rate of recombination in the base, but the slope of the hole-density curve with distance, which is proportional to collector current, remains nearly unchanged. The distribution of charge in the base then assumes the form of Fig. 12, which shows the two parts of the charge: Q_B ,

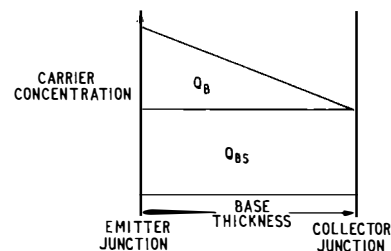

FIG. 12—BASE CONDITIONS IN A SATURATED TRANSISTOR

is proportional to collector current, and Q_{BS} depends on the excess base current.

The total time taken by the transistor to switch on is the time taken by the external circuit to supply the required change in charge, $Q_B + Q_E + Q_C$, plus the charge lost by recombination during the switching time. Q_{BS} is not involved since it is supplied after the completion of switch-on.

To switch the transistor off, the stored charge must be removed. This is usually done by connecting the base to a positive supply, although the transistor would still switch off if the base were disconnected or joined to earth because the charge would eventually be removed by recombination; this would result in a long switch-off time. Upon connexion of the switch-off signal to the base, the excess base charge, Q_{BS} , must be withdrawn before there is any decrease in collector current. This results in a delay, after which Q_B and, consequently, the collector current begin to decrease. At the same time, the voltage drop across R_L decreases causing the collector depletion layer to widen and necessitating a change in Q_C . Finally, when Q_B has been reduced to zero, the collector current will be zero and the transistor will be effectively switched off; but, to restore the transistor to its normal off condition, a change of Q_E must still occur in order to restore the emitter depletion layer to its original width in the off condition. Thus, the switch-off time is determined by the time taken by the external circuit, helped by recombination, to withdraw the charge $Q_{BS} + Q_B + Q_C$.

If the components of the charge could be calculated as simple functions of the operating conditions of the transistor it would be possible to predict the switching performance in any given circuit. This has been done for alloy-junction transistors¹¹ (see "The Transistor as a Charge-Controlled Device" above), but for high-speed switching transistors of the mesa and planar types the situation is greatly complicated by unwanted storage in regions belonging to the extrinsic transistor. These parasitic charges are large enough to upset the simple

approach which has been described, and circuit design is at present being carried out in rather empirical terms. As in the small-signal field, there is a need either for more detailed understanding of device operation or for the production of devices with simpler electrical behaviour.

CONCLUSIONS

It has been shown how the charge-control idea can be used to explain the basic behaviour of both amplifying and switching transistors, and to account for some of the phenomena which arise at high speeds and high frequencies of operation. Modern mesa and planar transistors, however, have their electrical performance at high frequencies complicated by the effects of the extrinsic transistor and by parasitic storage of carriers, and there is a need for better understanding of these effects.

References

- ¹ HENDERSON, J. C., and WILSON, SYLVIA J. Design and Technology of Silicon Planar Transistors. *P.O.E.E.J.*, Vol. 56, p.239, Jan. 1964.
- ² BASSETT, H. G. The Transistor, Part 6—Applications. *P.O.E.E.J.*, Vol. 48, p.47, Apr. 1955.
- ³ SPARKES, J. J. and BEAUFOY, R. The Junction Transistor as a Charge-Controlled Device. *A.T.E. Journal*, Vol. 13, p.310, 1957.
- ⁴ MIDDLEBROOK, R. D. An Introduction to Junction Transistor Theory (*John Wiley and Sons*, 1957), p.137.
- ⁵ ROLLETT, J. M. The Characteristic Frequencies of a Drift Transistor. *Electronics and Control*, Vol. 7, p.193, Sept. 1959.
- ⁶ MIDDLEBROOK, R. D. An Introduction to Junction Transistor Theory (*John Wiley and Sons*, 1957), p.229.
- ⁷ *ibid*, p.155-160.
- ⁸ *ibid*, p.163.
- ⁹ *ibid*, p.229.
- ¹⁰ PRICE, T. E. and HYDE, F. J. Base Resistance and Collector Capacitance of Alloy-Type Transistors. *Proceedings I.E.E.*, Part B, Vol. 109, p.115, Jan. 1962.
- ¹¹ SPARKES, J. J. The Measurement of Transistor Transient Switching Parameters. *Proceedings I.E.E.*, Part B, Vol. 106, p.562, May 1959.

Book Reviews

"Fernsehtechnik—Zweiter Teil." Technik des Elektronischen Fernsehens. Springer-Verlag. F. Schroter. xvi + 586 pp. 618 ill. 98 DM.

This book is one of a series of telecommunication text books and is the second of two volumes on television technique. While the first volume, published about six years ago, dealt with fundamental principles, this volume deals with the practical application of these principles.

The first two chapters are concerned with the problems of amplification, scanning and synchronization, as applied to current television practice, and provide a sound foundation for the understanding of the practical problems involved in transmitting, long-distance relaying, and receiving equipment, subjects which are dealt with extensively in subsequent chapters. There are also chapters dealing with camera techniques, recording apparatus, transmitting aerials and measuring techniques. A chapter on coverage prediction and network planning, not a subject found in television text books, is a welcome addition and is extremely informative. The volume concludes with three extremely interesting chapters on new and possible future developments, including such items as colour television, standards conversion including systems using different picture frequencies, the possibility of bandwidth reduction, and different methods of television picture display including electroluminescent display panels.

The book is the result of contributions from several authors (German) drawn from their industry, broadcasting authorities and Post Office; most of the authors are recognized internationally as authorities on various aspects of television engineering. The subject matter is consequently dealt with authoritatively, thoroughly and at the same time with continual reference to its practical application to modern equipment and techniques. The diagrams and illustrations are excellent, profuse and well annotated, and, as seems to be the practice with modern German text books, each chapter has a wealth of references.

It is an excellently produced book and in addition to being a first-class text book it provides a comprehensive survey of practical television technique as currently applied in Germany. It is indeed unfortunate that the language difference will limit its usefulness in this country.

R.P.F.

"Proceedings of the International Conference on the Physics of Semiconductors: Exeter 1962." The Institute of Physics and the Physical Society. xi + 909 pp. 390 ill. 210s.

An international conference on the physics of semiconductors has been held biennially since that at Reading in 1950 and has consistently brought together the leading workers in a subject which has grown in importance, influenced other fields and led to many applications. The growth indeed has been such that some restriction in coverage has become necessary at the conferences, e.g. radiation damage did not figure at Exeter. Of the key topics remaining, the transport of electrical carriers (electrons) continues to take a prominent place. The scattering processes to which the carriers are subject are still being studied, even in materials as well-established as germanium and silicon, with hot electrons—carriers which have acquired so much energy from an electric field as to cease to be in thermal equilibrium with the crystal—being given special attention. Tunnel effect, on the other hand, figured hardly at all.

Optical properties have long been a fruitful subject for study, helping to build up our overall picture of semiconductors and the role of impurities, but the 20 or more contributions at this conference seem disjointed and their importance difficult to judge. The group of papers on materials introduces a few comparatively new compounds as well as adding fresh information on such well established semiconductors as the lead salts (sulphide selenide and telluride), gallium arsenide and silicon carbide; the compounds between elements in columns II and VI of the periodic table attracted few papers, however. Surfaces were not forgotten and it is pleasing to see W. H. Brattain in action still, with an elegant technique for studying the germanium-electrolyte interface. The report concludes with two excellent summaries, one covering the experimental aspects and the other the theoretical. They may be personal opinions, but they single out the more important novel features and the unsolved problems, and suggest the areas where new work is needed and likely to be rewarding.

Engineers will not find this report easy reading, any more than that of the preceding conferences: but the subject is one which has already borne fruit for them in the transistor, Zener diode, varactor diode and tunnel diode and promises several new devices. They will find some study of the conference a guide to those things to come which will impinge on them.

J.R.T.

Notes and Comments

New Year Honours

The Board of Editors offers congratulations to the following engineers honoured by Her Majesty the Queen in the New Year Honours List:

Coventry Telephone Area	.. H. T. Trigg	.. Technical Officer	.. British Empire Medal
Edinburgh Telephone Area	.. J. M. Riva	.. Leading Technical Officer	British Empire Medal
Engineering Department..	.. R. W. White	.. Assistant Staff Engineer..	Officer of the Most Excellent Order of the British Empire
Engineering Department..	.. A. Lee	.. Technical Officer	.. British Empire Medal
Post Office Headquarters, Scotland	.. J. Gibson	.. Regional Motor Transport Officer	.. Member of the Most Excellent Order of the British Empire
Tunbridge Wells Telephone Area	.. J. W. Hotham	.. Executive Engineer	.. Member of the Most Excellent Order of the British Empire

Notes for Authors

Authors are reminded that some notes are available to help them prepare the manuscripts of the Journal articles in a way that will assist in securing uniformity of presentation, simplify the work of the Journal's printer and draughtsmen, and help ensure that authors' wishes are easily interpreted. Any author preparing an article for the Journal who is not already in possession of the notes is asked to write to the Managing Editor to obtain a copy.

It is emphasized that all contributions to the Journal, including those for Regional Notes and Associate Section Notes, must be typed, with double spacing between lines, on one side only of each sheet of paper.

Each circuit diagram or sketch should be drawn on a separate piece of paper; neat pencil sketches are all that are required. Photographs should be clear and sharply focused. Prints should preferably be glossy and should be unmounted, any notes or captions being written on a separate sheet of paper. Negatives or plates are not needed and should not be supplied.

Circulation of The Post Office Electrical Engineers' Journal

The Board of Editors is pleased to note the continuing increase in the circulation of the Journal, as shown by the following statistics.

Journal Issue	Number of Copies Printed
Vol. 56, Part 1, Apr. 1963	26,600
Vol. 56, Part 2, July 1963	27,300
Vol. 56, Part 3, Oct. 1963	27,800
Vol. 56, Part 4, Jan. 1964	28,400

Approximately 10 per cent of the Journals are sold to overseas readers in more than 50 countries.

Institution of Post Office Electrical Engineers

Retired Members

The following members, who retired during 1963, have retained their membership of the Institution under Rule 11 (a):

- W. T. Palmer, 12 Belsize Grove, Hampstead, London, N.W.3.
- G. A. Rutland, 75 Copt Elm Road, Charlton Kings, Cheltenham, Gloucester.
- G. J. Smith, 27 Wallingford Road, Handworth, Wilmslow, Cheshire.
- W. J. Pemberton, 12 Dentwood Grove, Bristol, 9.
- C. E. Moffatt, 53 Hill View, Westbury-on-Trym, Bristol.
- W. B. Duncan, M.B.E., No. 2A Dalavitch, By Taynuilt, Argyll, Scotland.
- J. Duff, 12 Woodbourne Road, Sale, Cheshire.
- J. G. Stratton, 1 Warltersville Way, Balcombe Road, Horley, Surrey.
- C. K. Jones, Moorsley Banks House, Crossgate Moor, Durham.
- A. W. Webb, 114 Henderland Road, Bearsden, Glasgow, Scotland.
- S. Pendry, 4 Poyle Road, Guildford, Surrey.

Subscriptions and Income Tax Relief

Members are reminded that, as announced in the April 1959 issue of the Journal, the Commissioners of Inland Revenue have approved the Institution of Post Office Electrical Engineers for the purposes of Section 16 of the Finance Act, 1958, and that the whole of the annual subscription paid by a member who qualifies for relief under that section will be allowable as a deduction from the amount of his salary assessable for income tax under Schedule E.

The relief has applied since the tax year ending 5 April 1959. Members (Corporate and Corresponding) should make claim for the relief to the appropriate tax offices on Form P358, which can be obtained from a tax office.

Nuffield Talking Book Library for the Blind

The above organization has asked the Institution to publicize its appeal for volunteers to help service long-playing-record and tape reproducer equipment in blind persons' homes. Post Office technical staff, by virtue of their knowledge and experience in this and allied fields, are clearly

well suited for this work. The machines are basically simple radio amplifiers, and full circuit diagrams and guidance notes would be provided.

Volunteers are required throughout the country and a central organization, based on Wembley, Middlesex, would contact a volunteer nearest the home of a blind person reporting a fault or asking for help.

Post Office staff willing to assist in this work, or requiring further information, should apply to Mr. D. Finlay-Maxwell, Honorary Organizer of Servicing Volunteers Nuffield Talking Book Library for the Blind, J. Gladstone & Co., Ltd., Galasheils, Scotland, in the first instance, who will supply all details.

It will be appreciated that neither the Post Office nor the Institution undertakes any responsibility in this matter and that all arrangements are between the volunteer and the Nuffield Talking Book Library organization.

S. WELCH,
General Secretary.

Additions to the Library

Library requisition forms are available from Honorary Local Secretaries, from Associate Section Centre Secretaries and representatives, and from the Librarian, I.P.O.E.E., G.P.O., 2-12 Gresham Street, London, E.C.2.

2738 *Automatic Control Handbook*. G. A. T. Burdett (Brit. 1962).

Surveys and provides practical information on all aspects of the subject. Covers mechanical, electrical, electronic, hydraulic, electro-hydraulic, pneumatic, pneumatic-hydraulic, electro-pneumatic, and process or temperature-operated control techniques.

2739 *Fundamentals of Ultrasonics*. J. Blitz (Brit. 1963).
A general textbook for physics students.

2740 *Digital Techniques*. D. W. Davies (Brit. 1963).
A book for those who use digital electronics as a tool rather than as an end in itself; the experimenter who wishes to prepare data for a computer rather than the computer designer.

2741 *Science, Industry and Social Policy*. K. Denbigh (Brit. 1963).
A commentary on the social aspects of applied science in industry.

2742 *Electric Space Heating*. J. J. Barton (Brit. 1963).
Aimed at electrical engineers and installation contractors as well as the general public.

2743 *More Mathematical Puzzles and Diversions*. M. Gardner (Amer. 1963).

A further selection from the "Scientific American".

2744 *Radio and Line Transmission Vol. 1*. G. L. Danielson and R. S. Walker (Brit. 1963).

Covers the syllabus for the Radio and Line Transmission A examination of the City and Guilds Telecommunication Technicians Course.

2745 *Colour Prints: The Photographic Technique of the Colour Positive*. J. H. Coote (Brit. 1963).

Covers the theory and practice of making colour prints.

2746 *The Young Scientist (a collection of articles by experts in various subjects)*. W. Abbott (Editor) (Brit. 1962).

An introduction to some of the fields of science open to young people.

2747 *Project Telstar*. G. Oakley (Brit. 1962).

Tells the story of the creation and launching of Telstar.

2748 *Teaching Machines*. B. Fine (Brit. 1963).

An explanation and evaluation of the new technique.

2749 *The Living Sea*. J. Y. Cousteau and J. Dugan (French 1963).

The experiences culminating in a stay of one week under water by two men.

2750 *Modern Physics (Including Atomic and Nuclear Physics)*. D. E. Caro, J. A. McDonell and B. M. Spicer (Brit. 1962).

Covers the subject at advanced level, but goes further than the immediate requirements of the examination.

2751 *Microwave Tubes and Semiconductor Devices*. G. D. Sims and I. M. Stephenson (Brit. 1963).

Surveys the principles of operation of microwave valves and their uses.

2752 *Transistor Television Receivers*. T. D. Towers (Brit. 1963).

Sets out the principal features of transistor television receivers and how they differ from valve sets. The approach is practical, and examples are drawn from various countries.

W. D. FLORENCE,
Librarian.

Book Review

"Transistor Television Receivers—a Survey of World Circuitry." T. D. Towers, M.B.E., H.A., B.Sc., A.M.I.E.E., Grad.Brit.I.R.E. Iliffe Books, Ltd., 194 pp. 188 ill. 55s.

As its title suggests, this book comprises a survey of the circuitry employed in commercially-produced, broadcast-television receivers. Designs from British, Japanese and U.S. practice form the bulk of the material used; one Russian receiver is discussed but, although the dust cover mentions French, German and Italian practice, no named examples are given.

The book is well produced, the diagrams are clear and the text has an easy style; British Standard Institution recommendations are not always followed but the departures are unlikely to disturb the average reader. There is no bibliography as such, but occasional references appear in the body of the text.

Existing circuit arrangements are systematically discussed in detail but the information given on design techniques and receiver performance is far from complete. Receivers for negative modulation and f.m. sound are mentioned in so far as they are used abroad, but there is no discussion of u.h.f. tuners or colour-television receivers. The impression obtained from the book is that while transistors offer considerable advantages for small, battery-driven, portable receivers, this is not yet so for normal domestic receivers; for example, transistors suitable for line-output stages to drive the larger picture tubes are only just becoming available.

The book would be difficult to follow without some prior knowledge of the principles of receiver design. It will be of most use to designers and service engineers wishing to enlarge their field to include transistor-type receivers. but other electronics engineers will find it of some interest.

J.W.A.

I.P.O.E.E. Library No. 2752.

Regional Notes

Scotland

BRIDGE COLLAPSE AT WILSONTOWN

The Denny-Libberton low-capacity carrier cables, which cross a gully at Wilsonstown via a bridge on the A706, were left with no visible means of support when part of the bridge collapsed in March, 1963.

As the ground in the vicinity of the parapets still standing was very unstable, it was necessary to devise some method of support which would distribute the load over as large an area as possible. The scarfed portions of two 24 ft light poles were bolted together and the 25 ft gap was bridged with an adequate overlap at each end.

The road authority took advantage of the situation to widen the bridge approximately 3 ft.

When the bridge had been rebuilt up to road level, the ducts were re-aligned and bedded in concrete.

G.N.C.

COAXIAL CABLES DAMAGED BY A BURST HYDRAULIC WATER MAIN

On Friday, 29 November, 1963, one tube of the Glasgow-Kirk o' Shots coaxial cable developed a short-circuit, and the fault was measured to the junction of George Street, and Shuttle Street, Glasgow. At this point eight coaxial cables, totalling 26 coaxial tubes, cross George Street, which is a main thoroughfare, and go down Shuttle Street to the television-network switching centre.

It had already been observed that the Glasgow Corporation Water Department were working at the junction of George Street and Shuttle Street, and on the Saturday morning the full extent of the damage became apparent. A hydraulic main had burst, and the water had poured into the railway tunnel, which passes under the road at this point, and churned out a large cavity under the roadway, undermining the Post Office ducts and other services. The roadway collapsed, as shown in the photograph, bringing down a



DAMAGE CAUSED BY THE BURST HYDRAULIC WATER MAIN

street-lighting standard and damaging the gas mains and domestic water mains as well as most of the eight coaxial cables.

Since the duct was damaged, it was necessary to do an overground substitution. A narrow channel was dug in the road surface down to the concrete base, and 16 coaxial interruption cables were laid across the road from the manholes on either side. All the working coaxial tubes were changed over by the Monday morning.

The Post Office work was slowed down over the weekend by the presence of gas and the necessity to repair the hydraulic main before the Post Office ducts could be fully exposed and the extent of the damage assessed. There was the fullest co-operation between all the services. At one time the Gas Department was cutting an electric cable with a Post Office hack-saw. Jacks from the Water Department were used to shore-up the sides of the excavation above the Post Office ducts. The Highways Department provided a mechanical shovel to remove surplus soil, the police provided very necessary control of traffic and the Post Office supplied flashing amber beacons either side of the road to warn the approaching traffic during the hours of darkness.

During the following week the damaged ducts and cables were recovered. New ducts were concreted into position and new cables drawn-in across the road. By the following Sunday the change-over of the eight coaxial cables was complete.

In spite of the extensive damage and the limited time during which work is permitted on television coaxial tubes, the whole operation was carried out remarkably quickly and with the minimum of interruption to service, particularly to the television programs.

P.H.M.

London Telecommunications Region

REBUILDING POLLARDS EXCHANGE MANHOLE

The work to be described extended over a period of fully six years from start to finish. The original manhole was far too small for the cables in it, let alone the anticipated growth. A duct seal had been provided between it and the cable chamber but, apart from the lead plate, there was no support for the cables passing through. The manhole was found to be built with three walls only, and was partially supported by the building foundations.

About the same time as the inadequacy of the exchange manhole became apparent, the water-tightness of the cable chamber was causing concern. As the asphalt tanking of the building had given way, it was decided to remove all fixings in the floor and walls of the cable chamber so that new cement renderings might be applied. Steelwork, which had been added to reinforce the cable chamber so that it could be used as an air-raid shelter, provided temporary ceiling supports with the aid of slotted bars and studding. The rendering of the cement was, as far as possible, a continuous operation; demarcation between old and new work resulted in some joints which tended to allow seepage of moisture, but the amount was very little and the work can be considered successful. New-style ironwork for supporting the cables was then planned, and in due course erected.

Meanwhile, trial excavations between the manhole and the kerb, and over the roof of the manhole, enabled the planning of a larger manhole to proceed. As the new manhole was to be connected to the structure of the exchange building, it was arranged for it to be built by the Ministry of Public Building and Works, which had a program of modernization to carry out, including the provision of a new public office. It was essential for the manhole work to be given priority as the new structure was to occupy nearly the whole width of the footway and would have completely blocked off access to the new office. The vacant ground-floor premises conveniently accommodated the building materials necessary, so reducing the encroachment into the roadway for pedestrians to a reasonable and safe minimum.

The original manhole had been connected to the sewer, but it could only be partially drained. As the new manhole had to be deeper to give more working space, a sump was provided and a float-operated electric pump installed. The

single duct seal separating the two chambers has been replaced by three others on the outgoing routes (up, down, and across the main road), a total of 54 ways. The opportunity was taken to build 14 additional steels into the boundary wall to provide for growth beyond the original planned limit of the first-floor main distribution frame.

A model was made, to one-twelfth scale, of the new manhole and the adjoining cable chamber. This model was used to determine the best plan for rearranging the cables, and was left on site as a guide to those carrying

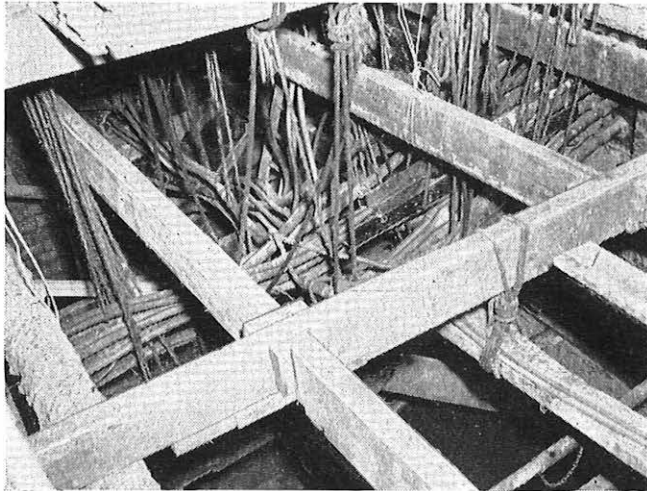

VIEW OF THE MANHOLE UNDER CONSTRUCTION AT POLLARDS EXCHANGE

out the work. As may be seen from the photograph, the cramped working conditions in the old manhole, the temporary slinging necessary while the new manhole was built, the transfer to ceiling supports while the floor was rendered, and the change to the final bearers were far from ideal for cabling. Only a few of the cables were planned to be renewed, or pieced out, and now it is hard to realize that many of the original cables appear in the finished work.

At a late stage in planning, the need for gas pressurization was made known, and, in conjunction with the overhaul of cables, gas seals were provided above the new tacking bars.

The whole operation was completed without any faults. Coaxial cables carrying television circuits were included among those rearranged. Great credit is due to the construction workmen whose patience was equal to the demands put upon them.

A.F.T.

Wales and Border Counties

LONG-LENGTH CABLING AT CHESTER

A major development scheme requiring $9\frac{1}{2}$ miles of experimental long-length cabling, using paper-core unit-twin (P.C.U.T.) polythene-sheathed and polythene unit-twin (U.T.) cables in sizes varying from 1,800 pr., 4 lb/mile to 250 pr., 10 lb/mile cable, is in progress at Chester.

The cable drums vary from 8 ft 0 in. to 4 ft 6 in. diameter, the heaviest drum weighing 4 ton 3 cwt. The lengths drawn-in varied from 791 yd of 1,400 pr., 4 lb/mile cable to 250 yd of 250 pr., 10 lb/mile cable. Most of these lengths needed the use of lengths of rope joined together by keystone links and swivels. The cable was connected to the pulling rope in the usual way, using cable grips and swivels, and the ends of the cables were consolidated by driving steel spikes, end on, into the core. A 4-ton diesel-driven hydraulic winch was used to draw in the cables, the rope speed of which is continuously variable from zero

to 100 ft/minute. Throughout the cabling, notes were taken of rope speeds and maximum rope tensions.

Where conditions made a single pull inadvisable, the cable was drawn-in in two parts. Firstly, the cable was pulled in one direction with the drum at an intermediate point. The remainder of the cable was then taken off the drum, laid in a figure of eight on the pavement, and then drawn-in in the other direction. As may be seen in the photograph, no difficulty was experienced in getting the centre of the bight into the shaft of a manhole. Experience



CENTRE OF THE BIGHT OF 1,800 PR., 4 LB/MILE POLYTHENE UNIT-TWIN CABLE ENTERING THE MANHOLE

showed that the length of the cables that could be drawn-in was limited mainly by two factors: the first is the size of the drum, the limit for which is thought to be 7 ft diameter, the second is the layout of the track. On straight tracks and tracks with a curve in one direction, no difficulty was experienced, but in S-shaped tracks the rope tension increased considerably. For one such length, it was necessary to fleet the cable from joint box to joint box. Cables were drawn-in around right-angle bends using cable-recovery rollers set up in the manhole at the bend. As each length was drawn-in, the ends were sealed using a lead plug. Schrader valves were fitted in the plug and the length put under pressure for 24 hours. Throughout all the cabling operations control was kept by v.h.f. radio, with sets at the drum and winch ends, and walkie-talkie sets at the intermediate points.

Jointing was conventional, the conductors being twist-jointed and insulated with paper or polythene sleeves depending on the type of cable. The sealing of the cables on the scheme was experimental, using polythene sleeves and epoxy putty. Some difficulty was experienced due to the strong smell of the putty, but this was overcome and it is expected that future supplies or changes in technique will eliminate this trouble altogether. The P.C.U.T. cables incorporated an aluminium-foil water barrier, which was bonded across at each joint with p.v.c.-insulated wire. The cable sheath and the polythene sleeve were prepared to receive the putty mixture by wrapping each with one turn of the polythene-coated aluminium tape. This was held in place with turns of copper wire, which was then heated until the polythene on the tape fused with the polythene of the cable sheath. The copper wire was then removed and the aluminium foil painted with clear Bostik. The putty mixture was then put on, and wiped using a moleskin and cold water. Each joint was fitted with a Schrader valve and tested to a pressure of 20 lb/in².

The polythene U.T. cables were terminated direct on the M.D.F., the cable being taken via the cable chamber

to the bottom horizontal bar of the M.D.F. At this point, the polythene sheath was stripped off and the pairs divided into groups of 400 pairs, each group being terminated on one vertical. Forming was done generally on the conventional lines although lacing was not used. The whole of the cable, from the bottom horizontal bar to the fuse mountings, was bound with a 50 per cent overlap of 1 in. plastic adhesive tape, which was coloured grey to suit the paintwork of the frame. The taped form was secured to the bars at 6 in. intervals using three overlapping turns of the tape.

This long-length cabling scheme resulted in a saving of both cabling and jointing time; for example, the number of joints was reduced by at least two thirds.

G.W.G.

Midland Region

INTRODUCTION OF TELEPRINTER AUTOMATIC SWITCHING AT THE ENGLISH ELECTRIC CO., LTD., STAFFORD

Following a survey of the teleprinter system used by the English Electric Co., Ltd., and its associated companies, it was decided to replace the existing manual system by an automatic switching system. The existing private network was served by a Switchboard Teleprinter No. 13, and had four local internal teleprinters and 11 external teleprinters as far afield as Bradford and London. To enable information on tape to be transmitted to any or all of the stations, an auto-transmitter was connected at the Stafford station. This network served the dense traffic routes and was augmented by normal Telex working for the less heavily loaded routes.

The automatic switching equipment needed to be installed in a room apart from the teleprinter room, and to solve accommodation problems it was decided to install the switching equipment in the telephone exchange at Stafford. Two Equipments Telex No. 1, with the junction circuits modified to permit back-to-back working, were installed, thus giving a fully automatic service to a maximum of 20 stations, with ten simultaneous interconnexions.

Arrangements were made by the Stoke-on-Trent Area for dialling facilities to be provided at all the existing teleprinter installations. This raised accommodation problems at several stations, and, where the new equipment could not be installed alongside the existing installation, the new station equipment was built up and tested in whatever accommodation was available and reinstalled in its permanent position on the day of the change-over.

At Stafford, a room adjacent to the existing switchboard and teleprinter room was provided and specially-designed bench-type tables were fitted along opposite walls of the room. One side of the room was fitted to take four stations, with an auto-transmitter switchable to two stations, and an off-line teleprinter. The other side took two pairs of Telex stations, sharing auto-transmitters, and had hatchways opening into the despatch room at each end, one for incoming and one for outgoing messages, thus avoiding the delays and interruptions caused by messages being delivered by staff.

As the existing manual-network circuits were to be used for the automatic network on transfer, it was arranged to test out all new stations during the week preceding the transfer by having the circuits released and switched, one at a time, to two of the Stafford stations which had been made to work on spare pairs back to the switching centre. This avoided any serious interruption of the existing network, tests being made during the quieter periods.

The conscientious efforts of all staff engaged on the installation and the excellent co-operation received from all Areas concerned, enabled the transfer to automatic working to be made smoothly and efficiently.

The photograph shows one side of the teleprinter room

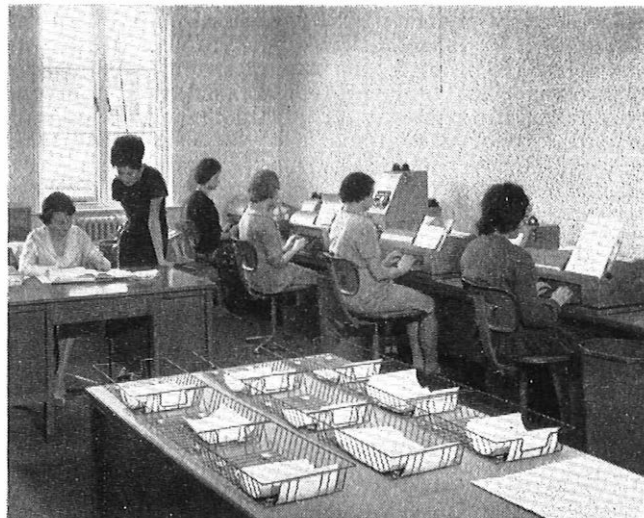

THE TELEPRINTER ROOM AT THE ENGLISH ELECTRIC CO., LTD.

at the English Electric Co., Ltd., Stafford. The noise in the room has been reduced by the use of acoustic tiles on all walls and the ceiling, and by floor carpeting; the overall effect is a room of pleasant, quiet efficiency.

W.H. & H.T.

Home Counties Region

THE MEDWAY BRIDGE ON THE M2 MOTORWAY

Advance ducts have been provided in the M2 motorway Medway Bridge, and consist of six ways in steel or pitch-fibre on the north side of the bridge, and a single 6 in. steel pipe on the south side. The 6 in. pipe is primarily intended for a possible future waveguide, but has also been utilized to carry the emergency telephone cable which runs throughout the length of the 25-mile-long motorway. Apart from electric cables for navigation lights and future street-lighting, the Post Office is the only public utility undertaking with plant installed in the bridge.

The bridge with its approach viaducts is 3,272 ft long and is constructed in pre-stressed concrete. The main river-spans, apart from a 100 ft section in the centre, were constructed in box-girder form of in-situ concrete and were cantilevered out from two main river-piers. The viaduct spans are of composite beam-and-slab construction as is the suspended span in the centre of the bridge, the deck of which is 116 ft above the ordnance datum-level. The photograph shows a general view of the bridge from the west bank.

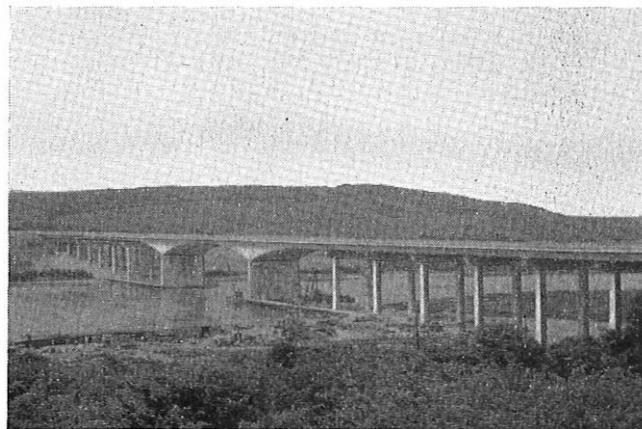

VIEW OF THE MEDWAY BRIDGE FROM THE WEST BANK

On the viaduct and the centre spans, the ducts (all of steel) were suspended from mild-steel cradles under the decks of both the north and south sides. The fastenings for these cradles were cast in the underside of the deck slab, and spaced at 10 ft intervals. To prevent injury to the duct protection, all hangers were wrapped with lappings of polyvinyl-chloride (p.v.c.) tape before being clamped in position.

The steel pipes were hoisted by crane to a convenient position near each abutment under the deck beams, and then manhandled out along the viaduct spans and lifted manually into position. This difficult and hazardous operation was carried out from scaffold planks supported on timber struts laid across the ledges at the base of the I-beams at a height of 50–100 ft above the ground. The cantilevered box-girder sections, which are 35 ft in height over the main river-piers, taper to allow about 6 ft of headroom at the ends of each arm. No advance ducts have been provided through these sections on the south side of the bridge as access is readily available should a wave-guide be required in the future. On the north side, however, a nest of six pitch-fibre pipes has been provided in flat formation. It is possible to walk through these sections, access being gained through openings in the hard shoulders at each end of the cantilever arms, and the ducts are supported just above floor level on wooden cradles bolted to the floor. The cradles are fitted at 10 ft intervals, and the ducts are clamped in position to prevent movement down the slopes of the arms towards the main river-piers. Cable bearers and anchor irons were cast into the walls to facilitate cable laying through the web over the piers.

There are 24 jointing chambers or access points, their entrances being situated in the hard shoulders along the length of the bridge. These have been provided:

- (a) where it was necessary to change direction of the ducts, e.g. at acceleration and deceleration zones,
- (b) at expansion joints and at either end of the 100 ft centre suspended span,
- (c) at the abutments at each end of the bridge, and
- (d) where required for pull-through and jointing purposes.

The jointing chambers are suspended from $\frac{5}{8}$ in. bolts cast into the underside of the deck slab, and are constructed with 3 in. \times 3 in. \times $\frac{3}{8}$ in. galvanized-steel angle-irons. Mild-steel cable-carrier trays, $\frac{1}{2}$ in. thick, form the ends of the chambers and will be used to support cables from the ducts to the floor of the chambers. Steel mesh, bolted into frames, completely surrounds each chamber to prevent personnel falling. All steelwork used for Post Office plant was galvanized and painted to prevent corrosion, and all lock-nuts used in the construction of jointing chambers

were tightened and tack-welded to stop them from being loosened by traffic vibration. The floors of the jointing chambers are of specially-selected soft wood treated with a copper-chrome water-borne preservative.

It was necessary to cater for the movements which will take place in the bridge as a result of temperature variations, and a typical arrangement of Post Office plant, excluding the cable, at an expansion joint is shown in the sketch. This is the joint, designed for a maximum lateral

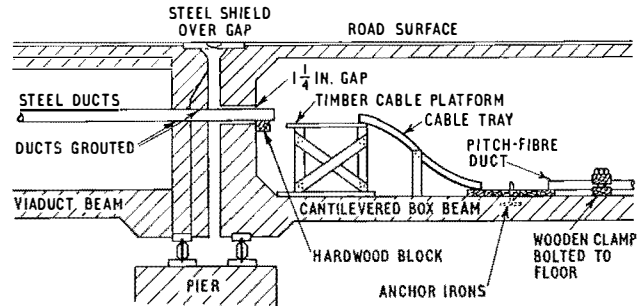

TYPICAL ARRANGEMENT AT AN EXPANSION JOINT

movement of 5 in., between a viaduct and a cantilevered span. The ducts passing through the ends of the viaduct beams are grouted in position, but pass through holes in the ends of the box girders with a clearance of $1\frac{1}{2}$ in. all round the pipes. At these points, the pipes rest on hardwood blocks bolted to the walls so that movements in the bridge do not damage the pipes. Timber cable-platforms have been fitted to accommodate the slack which will be left in each cable at this point to prevent them from being stretched and so damaged by lateral movements of the bridge. The sketch also shows the arrangement adopted for clamping the pitch-fibre ducts to the floors of the box-girder sections.

The west abutment of the bridge is formed in two parts; one part, which is also a bridge over the London–Ramsgate railway, is made with mass concrete, and the other is constructed with cellular reinforced-concrete. Advantage has been taken of the latter form of construction to transform two adjacent cells into jointing or access chambers by the addition of entrances, timber floors, and standard-type and wall-type cable bearers. This enables the duct lines to change direction from the hard shoulder to the verge where a 6-way earthenware duct has been laid across the slip road to the grass verge. From this position, the duct can readily be extended along the motorway as and when required.

J.I.W.

Associate Section Notes

Bletchley Centre

In October, a talk on the work of the Port of London Authority was given by Mr. Sharman, covering the history and constitution of the authority, its varied services to its customers in the Port of London, and the problem of working a port on tidal waters.

An "Any Questions?" panel was organized for November, the team being Mrs. Maude, Mr. F. J. Lee (Principal of the Regional Training School, Home Counties Region), Mr. Maxwell (prospective Labour candidate) and Mrs. Kellett (prospective Conservative candidate); Mr. A. H. C. Knox (Chief Regional Engineer) was Chairman for the evening.

In December, the new telephone exchange at Luton was visited after its official opening. Many members had been concerned in the construction of this large installation and so were pleased to see the end product; we are indeed all very grateful to the staff of Luton for showing us around.

Also in December, Mr. T. Quinn, of Creed and Co., Ltd., gave members a talk on the history and evolution of the teleprinter. Mr. Quinn described the various products from the wide range made by the company for the telegraph and data-processing fields, how they were developed, and how the company has progressed since the early 1900s.

In January, members visited G.E.C. (Telecommunications) Ltd., Coventry, where they viewed with interest the assembly and testing of 700-type telephones, switches and relays of all types, U.A.X. units, and transmission equipment. Visits were also made to the machine shops to see how the small parts that form the complex equipment were produced. This was followed by a visit to the transformer shops where many types of transformers, from the large to the very small, are made. This tour, which was made on a Friday, ended the week as a very enjoyable day out.

The membership of the Centre is now steady at about

110; although we gain new members, any increase is soon offset by members being promoted.

A.J.H.

Bath Centre

In July, a party of our members visited the horticultural research station, which is associated with the University of Bristol, at Long Ashton. Members were conducted on a tour of the laboratories and greenhouses where research into plant nutrition, virus control and plant breeding is carried on.

During August, a factory of W. D. and H. O. Wills, Bristol, the tobacco and cigarette manufacturers, was visited. The members of the party were shown the complete process of the manufacture of cigarettes, commencing with the reception of the tobacco from the bonded warehouses, to the dispatch of cigarettes by road and rail to various parts of the country.

Sunday, 15 September was the day chosen for a social event, a treasure hunt by car in the Cotswold country. It included a picnic in Badminton Park, and provided members and their families with a pleasant afternoon on one of the warmest and sunniest days of the year. Thanks are due to Messrs. M. J. Moxham and P. G. Martin for organizing a very entertaining event.

The first of the lectures of the winter session was held at the Technical College, Bath, where Mr. D. L. Benson, Telephone Electronic Exchange Systems Development Branch, Engineering Department, gave a very interesting lecture called "An Introduction to the Electronic Exchange." This meeting was well attended. The numerous and varied questions asked, indicated the interest shown in the subject by members of the audience.

In December, Mr. Rudge, Engineering Branch, South Western Region, gave an interesting talk on the development of subscriber trunk dialling (S.T.D.) in the Bath area, and also described the plans for the new telephone exchange now being built at Bath. This was followed by a paper entitled "Some Observations on S.T.D.," given by Mr. L. W. F. Vranck, Chairman of the Centre, who drew on his own experience of maintaining S.T.D. equipment to provide members with an interesting paper.

R.R.D.

Swindon Centre

A visit was made to Southampton docks in September, culminating in a conducted tour of the S.S. *United States*. Following this, in October, the final visit of the summer was made to the A.T.V. television studios at Boreham Wood.

Local Senior Section members Messrs. E. J. Hayward and J. Masefield commenced the winter activities by giving most interesting talks on "The Pay-On-Answer Coinbox" and "Maintenance Control," in October and November, respectively. Attendances at both of these meetings were most disappointing but the Committee are hopeful of better results with the planned future activities, which include a joint meeting with the Gloucester Centre.

A.J.B.

Barnstaple Section

The details of the 1963-64 program were as follows:
12 November: "The Fire Service," by Mr. L. F. Orgar, Divisional Officer, Devon Fire Service.

10 December: "Radio and T.V. Interference, and the Problems of T.V. Reception," by Mr. P. W. Crouch, Regional Office, Bristol.

14 January: "An Introduction to the Electronic Telephone Exchange," by Mr. D. L. Benson, Telephone Electronic Exchange Systems Development Branch, Engineering Department.

13 February: "P.B.X.'s—A Current Review of Development," by Mr. A. I. Forty, Subscribers' Apparatus and Miscellaneous Services Branch, Engineering Department.

10 March: "Nuclear Electric Power," by Mr. W. J. Prior, Station Superintendent, Hinkley Point atomic power station.

9 April: Annual general meeting, and a film show.

The Officers and Committee of the Centre are as follows: *Chairman*: Mr. R. H. Palmer; *Secretary*: Mr. H. J. Hutchings; *Treasurer*: Mr. F. D. Colwill; *Committee*: Messrs. J. N. Gould, W. W. Holbourn, C. H. Langdon, R. G. Lawrence, A. G. Somerville and C. L. Wright.

Interest in the activities of the Centre has been maintained, and membership is slowly growing. A trip made in the summer to the experimental satellite ground station at Goonhilly Downs was greatly appreciated and enjoyed by all.

H.J.H.

Reading Centre

The Reading Centre has again enjoyed a very successful season, evidenced by increased membership and attendance at meetings. The subjects this year have included a talk on the problems of atomic radiation in industry; an introduction to S.T.D. (the first of a series on the subject); a talk by a member, Mr. G. Toms, on radio interference, and an exciting quiz between Reading and Newbury Centres. The winning team are willing to challenge teams from neighbouring Centres.

Talks by our own members are enthusiastically received by large audiences, and the Centre is encouraging the members to contribute talks and papers by making an award on each successful occasion. In February, Mr. W. West of this Centre spoke about diode gate circuits. The concluding talk of the season is to be on the "M4 Motorway in Berkshire," by a member of the staff of the Berkshire County Council.

P.L.C.

Aberdeen Centre

On 26 October, a number of our members travelled by coach from Aberdeen to visit, in the morning, the air-traffic control tower at R.N.A.S. Lossiemouth, and, in the afternoon, Glenburgie distillery. Some of our out-station members joined the coach en route. In the air-traffic control tower, the party were shown the various operational features of flight control and direction finding, the meteorological room, and the air-traffic control room, the latter being perhaps the most interesting. A very enlightening explanation was given on the operation and layout of the air-traffic control desk, which had been developed after extensive work study. A very informative morning was the opinion of the party.

After an enjoyable lunch in Elgin, the party travelled about six miles for their next "port of call." Glenburgie distillery is small in comparison to the Speyside distilleries, but is perhaps unique in that it produces two distinct blends of spirit under the same roof. The batch process of making the malt whisky was followed through from the barley hoppers via the grain grinder, the sugar-extraction vats, the fermentation vats, the steam-heated stills, the spirit safe, to the final article.

Reluctantly, the party boarded the coach for the homeward journey after a very pleasant and enjoyable day.

Our November meeting consisted of a visit to International Computers and Tabulators, Ltd., Aberdeen, to which the staff of the Clerical, Sales, and Traffic Divisions were invited. Due to the large response received, we had to arrange for three visits on 28 November, 5 December and 16 January. A talk was given on the principles of a punched-card system and the machines used to perform different processes. An explanation was also given on the punched cards used for the telephone accounting system. A lively discussion followed the talk, and this slightly reduced the time left for demonstrating some of the machines.

D.W. and G.D.A.

Dundee Centre

Increased attendance brings ample reward to the committee, and the renewed interest being shown by members indicates even greater things to come. Since our excellent visit to Aberdeen in September, we have been informed by heads of Divisions under the title "What Does the Other Man Do?", advised about "The Stock Exchange," and have paid a visit to the sugar factory at Cupar, Fife. The closing meeting of December was an excellent film on "The Kariba Story."

The program for 1964 included a visit to Morphy Richards (Astral), Ltd., a talk on the "Tay Road Bridge," and a visit to Craigowl Hill for a lecture on "The Backbone System" and a look at the television link there

R.T.L.

Middlesbrough Centre

At the opening meeting, on 29 October, of the 1963-64 session, Mr. Purvis presented a paper entitled "The Development of the Motor Car." Some 20 members attended the meeting. Mr. Purvis dealt with every aspect of his subject from the days when the motor car was invented, the subsequent development of the early models, to the most recent invention, the rotary engine. At question time, many problems were discussed and solutions offered by the author.

On 26 November, Mr. E. A. Clarke presented an interesting and humorous lecture on "Photography." On this occasion 30 members attended.

On 17 December, 20 members visited the A.E.I. works at West Hartlepool to see the manufacture of telephone-exchange equipment and subscribers' apparatus, items so commonplace in our working day.

One of our members, Mr. D. Watkins, was awarded first prize in the North Eastern Region "Journal Shield Award—1963 Series" for his paper "The Search for Minerals."

At a committee meeting on 6 January, Mr. E. E. Sparkes was co-opted as Chairman, and Messrs. J. C. Meek and R. D. Purvis were co-opted to the Committee. The Centre would like to take this opportunity of recognizing the work done by Mr. Williams, who has recently been promoted to Assistant Engineer, during his years as Secretary and Chairman of the Middlesbrough Centre.

D.C.

Sheffield Centre

The 1963-64 session opened with a visit to the waggon works of Craven, Ltd., Sheffield. The party saw many kinds of coachwork for railway carriages and other modes of transport, used both in the United Kingdom and overseas.

In July, a party of members and their families enjoyed a day in Chester including a visit to Chester zoo. This was a social outing, thoroughly enjoyed by all who attended.

As a sequel to a recent lecture on domestic sound reproduction, a small party visited the factory of Wharfedale Wireless Works, Ltd., manufacturers of all kinds of loudspeakers. Mr. K. F. Russell, the technical manager and his assistant Mr. Jamieson, who presented a paper at the Centre two months ago, arranged the visit.

On 8 October, a party of members visited the Neepsend

power station, Sheffield. This station is of the older coal-burning type, but nevertheless makes a valuable contribution towards the ever-increasing demand for electricity. The Centre hopes to visit a modern power station shortly when members may compare the new with the old.

As is now usual at the Sheffield Centre, we held a joint Associate Section and Senior Section meeting. The very topical subject chosen by the Committee was "Town Planning and the Future Development of the Central Area," and was given by Mr. J. Nynn, the Assistant City Architect for the central area. The lecture was illustrated with slides, and Mr. Nynn outlined his ideas and proposals for the future development of Sheffield. A searching discussion ensued at question time. There is much to be learned about town planning, public and private transport considerations, and the advantages of concentrating buildings of high-rateable value into one area. An attendance of 50 did justice to one of the most interesting lectures for some time.

In November, a lecture entitled "The Work of the Post Office Cableships" was given to the Centre by Capt. J. P. F. Betson, Submarine Branch, Engineering Department. Capt. Betson showed a film and slides, and gave us a very descriptive study of the work of the cableships, with particular reference to the first Atlantic cable, laid by H.M.T.S. *Monarch*, of which Capt. Betson was Master before taking up his present post in the Engineering Department.

On 4 December, Mr. R. D. Y. Perrett, the Chief Telecommunications Superintendent of the Sheffield Area, gave a talk entitled "The Traffic Department and Allied Subjects." Mr. Perrett was given a gruelling time by many of the engineers at question time, but everyone left the meeting knowing a little more about the work of the Traffic Division than they had previously. Remaining subjects for meetings this season are quite varied, and the Committee look forward to increased interest and attendance at all our meetings.

D.A.

Bedford Centre

Since the last report, the membership of the Bedford Centre has increased from 80 to 119 members. The attendance at our first lecture, held on 31 October, 1963, was 28. Considering the fact that this meeting unavoidably clashed with another function, this was encouraging. The subject was "Rocket Propulsion," and was very well explained by Mr. D. Carton of the College of Aeronautics, Cranfield.

The subject of the next lecture, held on 9 December, was "Gas Pressurization of Cables," by Messrs. R. A. M. Light and H. P. Brooks, Main Lines Development and Maintenance Branch, Engineering Department, who brought with them an impressive array of equipment and demonstration models. This lecture was attended by 48 people, which is an indication of the growing enthusiasm of the membership.

On 16 January, a party of 20 visited the Post Office Research Station, Dollis Hill. The names of those going had to be drawn out of a hat as 33 wanted to go and the party had to be limited to 20. This visit was followed up on 4 March by a lecture, held at Bedford, entitled "Developments in Post Office Research," by Mr. J. Piggott, Research Branch, Engineering Department.

E.W.H.P.

Staff Changes

Promotions

Name	Region, etc.	Date	Name	Region, etc.	Date
<i>Area Engineer to Regional Engineer</i>			<i>Technical Officer to Assistant Engineer—continued</i>		
Horne, F. A. (<i>in absentia</i>)	Secondment	4.10.63	McWilliams, A. H.	Scot.	16.10.63
Halliday, C. L.	N.W. Reg. to Mid. Reg.	21.10.63	Sim, R.	N.E. Reg.	1.11.63
<i>Executive Engineer to Area Engineer</i>			Jenks, R. T.	W.B.C.	1.11.63
Lynas, T. W.	N.W. Reg.	2.10.63	Milne, W. M.	Scot.	4.11.63
Evans, J.	H.C. Reg. to Scot.	7.10.63	Cox, A. G.	Mid. Reg.	1.11.63
Phillips, H. A.	S.W. Reg. to N.I.	11.11.63	Ward, D. A.	Mid. Reg.	1.11.63
Simpson, E. J.	Scot. to N.W. Reg.	2.12.63	Kedge, R. G.	Mid. Reg.	1.11.63
<i>Executive Engineer (Open Competition)</i>			Allen, F. C.	Mid. Reg.	1.11.63
Pardington, I.	E-in-C.O.	7.10.63	Rogers, J. S.	H.C. Reg.	11.11.63
Pye, A. E.	E-in-C.O.	7.10.63	O'Malley, R. V.	E-in-C.O.	15.11.63
Fletcher, J. H.	E-in-C.O.	14.10.63	Evans, D. L.	H.C. Reg.	11.11.63
Stocker, J. F.	E-in-C.O.	11.11.63	Fagg, S. J.	H.C. Reg.	11.11.63
de Cruz, D. A.	E-in-C.O.	25.11.63	Wills, R. R.	H.C. Reg.	11.11.63
White, N.	E-in-C.O.	23.12.63	Evans, W. O. D.	H.C. Reg.	11.11.63
<i>Assistant Engineer to Executive Engineer</i>			Payne, L. A.	H.C. Reg.	11.11.63
Baynham, L. J.	Mid. Reg.	26.9.63	Knightson, L. G.	E-in-C.O.	15.11.63
Hardie, J. B.	Scot.	26.9.63	Underwood, J. K.	H.C. Reg.	11.11.63
Keast, M. H.	S.W. Reg. to W.B.C.	14.10.63	Kentsley, J.	H.C. Reg.	11.11.63
Glass, V. G.	L.T. Reg.	16.10.63	Allen, J. M.	H.C. Reg.	11.11.63
Loyns, H.	W.B.C.	17.10.63	Hewartson, D. H.	N.W. Reg.	7.11.63
Mettem, D. H. W.	H.C. Reg.	22.10.63	Lowe, D.	N.W. Reg.	7.11.63
Johnston, M.	E.T.E.	28.10.63	Marshall, H. J.	L.P. Reg.	7.11.63
Hayward, R.	H.C. Reg. to E-in-C.O.	28.10.63	Greenfield, J. R.	L.P. Reg.	7.11.63
Brown, F. A.	H.C. Reg.	5.11.63	Dengel, R. J.	L.T. Reg.	15.11.63
Knight, C. D.	H.C. Reg. to E-in-C.O.	25.11.63	Mercer, A. E.	H.C. Reg.	29.11.63
Gurton, R. A.	L.T. Reg.	6.11.63	Guest, K. E.	H.C. Reg.	25.11.63
Priestley, W. D.	E-in-C.O.	25.11.63	Coward, G. F.	H.C. Reg.	25.11.63
Jones, E.	N.W. Reg.	12.11.63	Young, R. S.	H.C. Reg.	25.11.63
Porter, A. W.	N.W. Reg.	12.11.63	Cooper, G.	H.C. Reg.	25.11.63
Courtis, T. H.	Mid. Reg.	25.11.63	Larmen, W. R.	H.C. Reg.	25.11.63
Tough, J. L.	S.W. Reg.	18.11.63	Hartley, J. P.	H.C. Reg.	25.11.63
Curbishley, R.	N.W. Reg.	25.11.63	Corrall, C. W.	H.C. Reg.	25.11.63
Wilson, S.	Scot.	2.12.63	Ludlow, D.	H.C. Reg.	25.11.63
Harris, J. C.	N.W. Reg.	12.12.63	Vass, J. W. A.	H.C. Reg.	25.11.63
Keller, J. P.	L.T. Reg. to E-in-C.O.	9.12.63	Golesworthy, H. M. G.	H.C. Reg.	25.11.63
Anderson, A. C.	S.W. Reg. to H. C. Reg.	18.12.63	Moore, H. J.	H.C. Reg.	25.11.63
Lankester, J.	L.T. Reg.	2.12.63	Lines, N.	H.C. Reg.	25.11.63
<i>Assistant Engineer (Open Competition)</i>			Wakelin, P. T. H.	L.T. Reg.	7.11.63
Legood, R. K.	E-in-C.O.	26.11.63	Tooth, A. J.	H.C. Reg.	29.11.63
Collins, M. W. J.	E-in-C.O.	26.11.63	Buckley, D. E. M.	N.E. Reg.	16.9.63
Rainey, J. T.	E-in-C.O.	9.12.63	Madders, K. D.	Mid. Reg.	16.12.63
Marshall, I. R.	E-in-C.O.	26.11.63	Hawkes, D. F.	H.C. Reg.	5.12.63
Roberts, A. J.	E-in-C.O.	26.11.63	Robbins, E. C.	H.C. Reg.	5.12.63
Dunk, K. R. E.	E-in-C.O.	26.11.63	Williams, R. C.	H.C. Reg.	5.12.63
Howell, R. G.	E-in-C.O.	26.11.63	Furber, W. H.	H.C. Reg.	5.12.63
Stechman, D. F.	E-in-C.O.	26.11.63	Rayner, R. S.	H.C. Reg.	5.12.63
Cross, R. A.	E-in-C.O.	26.11.63	Allflat, R. J. P.	H.C. Reg.	5.12.63
Alexander, J. C.	E-in-C.O.	26.11.63	Sutton, D. A. W.	H.C. Reg.	5.12.63
<i>Inspector to Assistant Engineer</i>			Lee, A. G.	H.C. Reg.	5.12.63
Bentley, B.	N.E. Reg.	3.10.63	Goodwin, C. E.	H.C. Reg.	5.12.63
Clatworthy, A. R.	H.C. Reg.	31.10.63	Hill, C. L. I.	H.C. Reg.	5.12.63
White, M. J.	H.C. Reg.	31.10.63	Webb, P. J.	H.C. Reg.	5.12.63
Clegg, E. R.	N.W. Reg.	30.10.63	May, A. D. J.	H.C. Reg.	5.12.63
Murray, W.	N.W. Reg.	18.11.63	Elkins, F. O.	H.C. Reg.	5.12.63
Carr, G. R.	N.W. Reg.	26.11.63	Wood, R. M.	H.C. Reg.	5.12.63
Spencer, L. H.	L.T. Reg.	15.11.63	Everett, B. W.	H.C. Reg.	5.12.63
Allen, S. R.	L.T. Reg.	15.11.63	Evans, G. E.	H.C. Reg.	5.12.63
<i>Technical Officer to Assistant Engineer</i>			Shaw, E. W.	H.C. Reg.	5.12.63
Peers, J.	N.W. Reg.	21.10.63	Lukehurst, R. J.	H.C. Reg.	5.12.63
Emerson, J.	Mid. Reg.	4.10.63	Baker, J. W. O.	H.C. Reg.	5.12.63
Surtees, J.	N.E. Reg.	3.10.63	Kelly, J. R.	H.C. Reg.	5.12.63
Grace, P. R.	S.W. Reg.	3.10.63	Parry, A. J.	H.C. Reg.	9.12.63
Compton, P. E.	S.W. Reg.	21.10.63	Hatch, B. T.	H.C. Reg.	5.12.63
Wallis, J. A.	S.W. Reg.	3.10.63	Tanswell, L. R.	H.C. Reg.	4.12.63
			Harmes, R. A.	H.C. Reg.	30.12.63
			Sharman, D. W.	Mid. Reg.	11.12.63
			Needham, P.	Mid. Reg.	11.12.63
			Bailey, J. G.	Mid. Reg.	16.12.63
			Brooks, N.	Mid. Reg.	11.12.63
			Holt, S.	N.W. Reg.	16.12.63
			West, L.	N.W. Reg.	3.12.63
			Mullen, P.	N.W. Reg.	16.12.63
			Thatcher, G.	N.W. Reg.	3.12.63
			Vallett, R.	N.W. Reg.	16.12.63

Promotions—continued

Name	Region, etc.	Date	Name	Region, etc.	Date
<i>Technical Officer to Assistant Engineer—continued</i>			<i>Technician I to Inspector—continued</i>		
Griffiths, H.	N.W. Reg.	3.12.63	Loughran, J. J.	Mid. Reg.	12.11.63
Sweetman, F. J.	N.W. Reg.	16.12.63	Williams, H. L.	Mid. Reg.	12.11.63
Fry, E. H.	E.-in-C.O.	17.12.63	Chasty, P. W.	H.C. Reg.	9.12.63
Love, G. A. H.	E.-in-C.O.	17.12.63	McClennan, F. R.	H.C. Reg.	9.12.63
Pindar, P. J.	E.-in-C.O.	17.12.63	Oakley, D. A. S.	H.C. Reg.	30.12.63
Slamon, C. J.	E.T.E. to E.-in-C.O.	17.12.63	Chilton, K. L.	H.C. Reg.	5.12.63
French, R.	E.-in-C.O.	17.12.63	Basford, F.	Mid. Reg.	11.12.63
Madder-Smith, K. B.	H.C. Reg.	10.12.63	Crisp, E. F. A.	H.C. Reg.	16.12.63
Page, L. C.	E.-in-C.O.	17.12.63	Walker, J. R.	W.B.C.	14.12.63
Gregory, E. C.	E.-in-C.O.	17.12.63	Gilbert, K.	H.C. Reg.	5.12.63
Catran, D. B.	E.-in-C.O.	17.12.63	Young, G. J.	H.C. Reg.	23.12.63
Smith, P. R.	E.-in-C.O.	17.12.63			
Balls, G. C. J.	E.-in-C.O.	17.12.63			
Stewart, J. M.	L.T. Reg. to E.-in-C.O.	17.12.63	<i>Senior Experimental Officer to Chief Experimental Officer</i>		
Trott, C. E.	E.-in-C.O.	17.12.63	Child, M. R.	E.-in-C.O.	1.11.63
Kipp, D. E.	E.-in-C.O.	17.12.63			
Holden, F. E. J.	E.T.E. to E.-in-C.O.	17.12.63	<i>Senior Scientific Officer (Open Competition)</i>		
Williams, N.	N.E. Reg. to E.-in-C.O.	17.12.63	King, D. E. N.	E.-in-C.O.	1.10.63
Lewis, R. H.	E.T.E. to E.-in-C.O.	17.12.63			
Jones, R. G.	E.-in-C.O.	17.12.63	<i>Scientific Officer (Open Competition)</i>		
Halton, R. G.	H.C. Reg. to E.-in-C.O.	17.12.63	Blain, B. J.	E.-in-C.O.	22.10.63
Tryhorn, R. W.	E.T.E. to E.-in-C.O.	17.12.63	Morgan, P. M. (Miss)	E.-in-C.O.	18.10.63
Skinner, C. J.	E.-in-C.O.	17.12.63			
Haworth, C. H.	N.W. Reg. to E.-in-C.O.	17.12.63	<i>Assistant Experimental Officer (Open Competition)</i>		
Dawton, D. B.	E.-in-C.O.	17.12.63	Upton, J. B. (Miss)	E.-in-C.O.	6.11.63
Groves, J. G.	H.C. Reg. to E.-in-C.O.	17.12.63	Dunn, P. J.	E.-in-C.O.	25.11.63
Emery, D.	N.E. Reg. to E.-in-C.O.	17.12.63			
While, B. H.	N.W. Reg. to E.-in-C.O.	17.12.63	<i>Assistant (Scientific) (Open Competition)</i>		
Wheeler, P. J.	L.T. Reg. to E.-in-C.O.	17.12.63	Baccus, H.	E.-in-C.O.	1.11.63
Dorothy, C. A.	E.-in-C.O.	17.12.63	Adamson, B.	E.-in-C.O.	4.11.63
Pearce, E. V.	E.-in-C.O.	17.12.63	Dudley, J. E.	E.-in-C.O.	6.11.63
Piercy, W.	E.-in-C.O.	17.12.63			
Clipstone, J. E.	E.-in-C.O.	17.12.63	<i>Workshop Supervisor I to Technical Assistant</i>		
Clay, J. P.	E.-in-C.O.	17.12.63	Howe, F. B.	Mid. Reg.	31.10.63
Costin, K. W.	L.T. Reg. to E.-in-C.O.	17.12.63			
Wright, D. K.	L.T. Reg. to E.-in-C.O.	17.12.63	<i>Workshop Supervisor II to Technical Assistant</i>		
Gillard, D. E.	S.W. Reg. to E.-in-C.O.	17.12.63	Jugg, J. Y.	S.W. Reg. to E.-in-C.O.	30.12.63
Devine, A. E.	H.C. Reg.	10.12.63	Goodrum, W. J.	E.-in-C.O.	10.12.63
Hammond, J. B.	H.C. Reg.	10.12.63			
Whitchurch, V. C.	S.W. Reg.	16.12.63	<i>Workshop Supervisor III to Technical Assistant</i>		
Richards, C. A.	S.W. Reg.	16.12.63	Webb, D. W.	E.-in-C.O. to London Reg.	21.10.63
Barnes, L. L.	L.T. Reg. to E.-in-C.O.	30.12.63			
Kirkby, A. D.	L.T. Reg. to E.-in-C.O.	30.12.63	<i>Draughtsman to Leading Draughtsman</i>		
<i>Draughtsman to Assistant Engineer</i>			Pollard, H.	E.-in-C.O.	26.9.63
Woodward, B. B.	H.C. Reg.	29.11.63	Williams, J. E.	E.-in-C.O.	26.9.63
Radford, L. S.	H.C. Reg.	10.12.63	Redhead, J. C.	L.P. Reg. to E.-in-C.O.	26.9.63
<i>Technical Officer to Inspector</i>			Andrews, D.	E.-in-C.O.	26.9.63
Tomkins, K. G. H.	H.C. Reg.	11.11.63	Steele, D. G.	E.-in-C.O.	26.9.63
Ralphs, J. W.	W.B.C.	14.11.63	Webster, E. D. B.	N.E. Reg.	7.10.63
Weightman, H.	L.T. Reg.	15.11.63	Thomas, R. S.	W.B.C. to S.W. Reg.	22.10.63
<i>Technician I to Inspector</i>			Porter, L. R.	N.W. Reg. to N.E. Reg.	31.10.63
Summers, J. G.	S.W. Reg.	7.10.63	<i>Higher Executive Officer to Senior Executive Officer</i>		
Rennie, F. J.	Scot.	1.10.63	Diamond, W. B.	Treasury	12.6.63
McAndrews, J.	N.E. Reg.	3.10.63	<i>(in absentia)</i>		
Browning, K.	L.T. Reg.	4.10.63	<i>Executive Officer (Open Competition)</i>		
Oldfield, D.	W.B.C.	28.10.63	Bruce, D. M. (Miss)	E.-in-C.O.	14.10.63
Watson, E. J.	S.W. Reg.	12.11.63	Clay, J. B. C.	E.-in-C.O.	18.11.63
Hack, J. G. W.	H.C. Reg.	12.11.63			
Clarke, D. F.	H.C. Reg.	12.11.63	<i>Clerical Officer to Executive Officer</i>		
Goff, J. G.	H.C. Reg.	12.11.63	Hardy, D. H.	E.-in-C.O.	19.11.63
Hamilton, C. B.	H.C. Reg.	25.11.63	Frost, G. M. (Mrs.)	E.-in-C.O.	25.11.63
Brench, J. R.	H.C. Reg.	12.11.63	Dougall, A.	E.-in-C.O.	23.12.63
Wilson, S.	H.C. Reg.	12.11.63			
Rodgers, A. T.	H.C. Reg.	12.11.63			
Mahoney, S. V.	H.C. Reg.	12.11.63			
Severn, J.	H.C. Reg.	18.11.63			
Wake, F. D.	H.C. Reg.	29.11.63			
Holland, R. V.	H.C. Reg.	12.11.63			
O'Connor, C. C. E.	Mid. Reg.	12.11.63			
Daniel, R. R.	Mid. Reg.	12.11.63			
Treadwell, E. A.	Mid. Reg.	12.11.63			

Retirements and Resignations

Name	Region, etc.	Date	Name	Region, etc.	Date
<i>Area Engineer</i>			<i>Assistant Engineer—continued</i>		
Riley, C.	H.C. Reg.	31.12.63	Latham, A. E.	W.B.C.	20.11.63
Thomas, G. E. T.	N.E. Reg.	31.12.63	Procter, L.	N.W. Reg.	25.11.63
<i>Senior Executive Engineer</i>			Seddon, T.	N.W. Reg.	29.11.63
Thwaites, H. J.	E.T.E.	31.12.63	Wright, J. R.	L.T. Reg.	30.11.63
<i>Executive Engineer</i>			Deller, A. F.	H.C. Reg.	30.11.63
Miller, E. W.	H.C. Reg.	31.10.63	Fenner, A. G. (<i>Resigned</i>)	E.-in-C.O.	4.11.63
Porter, R. W. R.	Mid. Reg.	1.11.63	McBean, H.	Scot.	11.10.63
Jimpson, S. J.	E.T.E.	2.11.63	Rudham, J.	L.T. Reg.	6.12.63
Wilson, T. M.	E.T.E.	19.11.63	Owen, E.	E.T.E.	27.12.63
<i>Assistant Engineer</i>			Penny, W. J.	H.C. Reg.	30.12.63
Stephens, C. W.	L.T. Reg.	14.5.63	O'Brien, E. J.	H.C. Reg.	31.12.63
Dean, J. E.	H.C. Reg.	4.7.63	Clark, W. R.	E.T.E.	31.12.63
Squelch, J. H. A.	H.C. Reg.	6.7.63	Owens, I.	W.B.C.	31.12.63
Richardson, C. F.	H.C. Reg.	1.8.63	Forsyth, C. D. (<i>Resigned</i>)	E.-in-C.O.	6.12.63
Bishop, H. H.	H.C. Reg.	31.8.63	<i>Inspector</i>		
Clear, P.	H.C. Reg.	24.9.63	Welsh, M.	N.I.	11.10.63
Richardson, D. B.	H.C. Reg.	29.9.63	Jones, T. S.	W.B.C.	7.11.63
Newton, C. E.	E.-in-C.O.	4.10.63	Barker, J. A.	L.T. Reg.	7.11.63
James, C. H.	E.-in-C.O.	9.10.63	Elliott, L. E. A.	L.T. Reg.	15.11.63
Brierley, J. E. B.	N.W. Reg.	16.10.63	Wilkinson, J. E.	L.T. Reg.	26.11.63
Thomas, G. E.	L.T. Reg.	17.10.63	Adam, J.	Scot.	28.9.63
Gardiner, T. H.	N.W. Reg.	19.10.63	Bright, E. G.	S.W. Reg.	31.10.63
Price, F. C.	N.I.	22.10.63	Brown, A. T.	N.E. Reg.	4.12.63
Briggs, E.	N.W. Reg.	30.10.63	McClelland, J. H.	S.W. Reg.	18.12.63
Preston, A. J.	L.T. Reg.	31.10.63	Watson, W.	L.T. Reg.	31.12.63
Pickford, H. D.	E.-in-C.O.	6.10.63	<i>Assistant Experimental Officer</i>		
(<i>Resigned</i>)			Fairbrother, L. R.	E.-in-C.O.	11.10.63
Stevens, W. H. (<i>Resigned</i>)	E.-in-C.O.	18.10.63	<i>Assistant (Scientific)</i>		
Gough, F. E.	L.T. Reg.	2.11.63	Kirton, V. I. (<i>Resigned</i>)	E.-in-C.O.	21.10.63
Bell, W.	N.E. Reg.	2.11.63	Stannard, A. P.	E.-in-C.O.	25.10.63
Meredith, W.	Mid. Reg.	4.11.63	<i>Higher Executive Officer</i>		
Osbaldeston, H.	N.W. Reg.	6.11.63	Burrows, W. H.*	E.-in-C.O.	23.12.63
Bennett, J. B.	E.-in-C.O.	13.11.63	* Mr. W. H. Burrows is continuing as a disestablished officer with E.-in-C.O.		
Worker, E. F.	L.T. Reg.	15.11.63			
Kirkham, J.	N.W. Reg.	17.11.63			
Whitfield, G. V. T.	L.T. Reg.	19.11.63			

Transfers

Name	Region, etc.	Date	Name	Region, etc.	Date
<i>Executive Engineer</i>			<i>Assistant Engineer—continued</i>		
Awberry, W. A.	E.-in-C.O. to W.B.C.	7.10.63	Phelps, G. E.	E.-in-C.O. to Ministry of Aviation	11.11.63
Chatwin, W.	N.W. Reg. to Ceylon	26.10.63	Matthews, D. H.	E.-in-C.O. to L.T. Reg.	18.11.63
Gates, N. P.	H.C. Reg. to Bermuda	24.11.63	Churchus, D. B.	E.-in-C.O. to L.T. Reg.	25.11.63
Seamans, K. R.	H.C. Reg. to Hong Kong	18.11.63	Lovering, R. T.	Gambia to E.-in-C.O.	21.12.63
Heywood, A. W.	Approved Employment to L.T. Reg.	1.11.63	Stubbs, D. L.	E.-in-C.O. to N.W. Reg.	30.12.63
Bordiss, H. J. K.	E.-in-C.O. to H.C. Reg.	25.11.63	<i>Higher Executive Officer</i>		
Whitton, H. E.	E.-in-C.O. to H.C. Reg.	2.12.63	Rainbird, F. C.	E.-in-C.O. to C.M.B. Department	11.11.63
<i>Assistant Engineer</i>					
Long, J. E.	E.-in-C.O. to Mid. Reg.	28.10.63			
Hearn, A. F. L.	E.-in-C.O. to H.C. Reg.	4.11.63			

Deaths

Name	Region, etc.	Date	Name	Region, etc.	Date
<i>Regional Engineer</i>			<i>Assistant Engineer</i>		
Devereux, R. C.	L.T. Reg.	22.10.63	White, D. L.	L.T. Reg.	29.5.63
<i>Executive Engineer</i>			MacGuire, J.	Scot.	23.7.63
Bett, H.	H.C. Reg.	9.12.63	Williams, F. G.	L.T. Reg.	18.10.63
			Ireland, A. E.	L.T. Reg.	4.11.63

Deaths—continued

Name	Region, etc.	Date	Name	Region, etc.	Date
<i>Assistant Engineer—continued</i>			<i>Inspector—continued</i>		
Cunningham, J. C.	Scot.	16.11.63	Yearsey, H. A.	Mid. Reg.	16.8.63
Ireland, F. E.	S.W. Reg.	18.11.63	Fergusson, W. A.	L.T. Reg.	16.11.63
Claridge, F.	Mid. Reg.	19.11.63	Pimblott, F.	N.W. Reg.	24.12.63
Selby, E. J.	E.-in-C.O.	3.12.63	<i>Senior Draughtsman</i>		
Haines, H. E.	L.T. Reg.	23.12.63	Harding, J. F.	E.-in-C.O.	7.5.63
<i>Inspector</i>			<i>Executive Officer</i>		
Conway, J. H.	N.F. Reg.	25.7.63	Dudbridge, J. (Miss)	E.-in-C.O.	20.8.63
Sugden, D.	N.F. Reg.	27.6.63			

Papers and Articles on Telecommunications and Other Scientific Subjects

The following is a list of the authors, titles and places of publication of papers and articles written by Post Office staff (sometimes in association with members of other organizations) and published during 1963.

- ALLNATT, J. W. A Possible Method for Estimating the Effect on Television Reception of Multiple-Interference Subject to Spatial and Temporal Variations. *I.E.E. Conference Report Series No. 5*, Paper No. 3,968E, p. 118, June 1963.
- ALLNATT, J. W., MILLS, D. E., and LOVELESS, E. R. The Subjective Effect of Co-Channel and Adjacent-Channel Interference in Television Reception. *I.E.E. Conference Report Series No. 5*, Paper No. 3,941E, p. 109, June 1963.
- ALLNATT, J. W., MILLS, D. E., THURLOW, E. W., and RICHARDSON, F. S. The Use of Tropospheric Scatter Propagation for Television Transmission. *I.E.E. Conference Report Series No. 5*, Paper No. 4,112E, p. 231, June 1963.
- BAKER, D. Inleakage and Outgassing of Transistors Encapsulated by Cold Welding and Electric Welding. *Le Vide*, Vol. 106, p. 363, July-Aug. 1963.
- BAKER, D., and TILLMAN, J. R. The Preparation of Very Flat Surfaces of Silicon by Electro-Polishing. *Solid State Electronics*, Vol. 6, p. 589, Nov.-Dec. 1963.
- BAMPTON, J. F., and KELLY, P. T. F. "And Now—TAT-3." *Post Office Telecommunications Journal*, Vol. 15, p. 17, Winter 1963.
- BAMPTON, J. F., GRIFFITH, R. G., and HALSEY, R. J. Anglo-Canadian Transatlantic Telephone Cable (CANTAT)—Planning and Overall Performance. *Proceedings I.E.E.*, Vol. 110, p. 1,115, July 1963.
- BASSETT, H. G. A Wide-Band Jig for the Measurement of the Current Gain of Transistors in the Frequency Range 20–10,000 Mc/s. *Proceedings I.E.E.*, Vol. 110, p. 35, Jan. 1963.
- BATES, Capt. O. R., and BROCKBANK, R. A. Anglo-Canadian Transatlantic Telephone Cable (CANTAT)—Laying the North Atlantic Link. *Proceedings I.E.E.*, Vol. 110, p. 1,159, July 1963.
- BORROFF, MISS E. M. Tracking Down the Rot. *Post Office Telecommunications Journal*, Vol. 15, p. 26, Winter 1963.
- BRAY, W. J. The World Wide Relaying of Television by Artificial Earth Satellites. *I.E.E. Conference Report Series No. 5*, Paper No. 4,031E, p. 563, June 1963.
- BRICE, P. J., and EVANS, G. O. Performance of Long Distance H.F. Radio Links Terminating in the U.K. *I.E.E. Conference on H.F. Communication*, p. 7, Mar. 1963 (*Proceedings I.E.E.*, Vol. 110, p. 1,514, Sept. 1963).
- BRICE, P. J., and SANDELL, R. S.* Field Strength Measurements of U.H.F. Transmissions from Crystal Palace. *I.E.E. Conference Report Series No. 5*, Paper No. 4,158E, p. 127, June 1963.
- BROCKBANK, R. A., see BATES, Capt. O. R.
- BROCKBANK, R. A., CLARKE, E. F. S., and JONES, F. Anglo-Canadian Transatlantic Telephone Cable (CANTAT)—Cable Development, Design and Manufacture. *Proceedings I.E.E.*, Vol. 110, p. 1,124, July 1963.
- BROWNLIE, J. D. Small-Signal Responses Realizable from D.C. Biased Devices. *Proceedings I.E.E.*, Vol. 110, p. 823, May 1963.
- CAMPBELL, D. A. Aluminium Films. *Journal of the British Astronomical Association*, Vol. 73, p. 249, Aug. 1963.
- CATT, L. H. Power Plant for British Post Office Telephone Exchanges. *I.P.O.E.E. Printed Paper No. 221*, 1963.
- CHAPMAN, K. J., see CLARKE, E. F. S.
- CLARKE, E. F. S., and CHAPMAN, K. J. Anglo-Canadian Transatlantic Cable (CANTAT)—Cable-Laying Gear. *Proceedings I.E.E.*, Vol. 110, p. 1,151, July 1963.
- CLARKE, E. F. S., see BROCKBANK, R. A.
- COPPING, G. P. High-Speed Paper-Feed Mechanism. *Machine Design Engineering*, Vol. 1, p. 24, Oct. 1963.
- CREIGHTON, J. L., HUTTON-PENMAN, P. R., and DAVIES, W. M. Developments in Long-Distance H.F. Point-to-Point Communications. *I.E.E. Convention on H.F. Communication*, p. 264, Mar. 1963. (*Proceedings I.E.E.*, Vol. 110, p. 1,411, Aug. 1963.)
- DAGLEISH, D. I., see MORRIS, D. W.
- DAVIES, W. M., see CREIGHTON, J. L.
- DAVISON, G. N. The Coding and Automatic Sorting of Letters. *Transactions of the Society of Instrument Technology*, Vol. 15, p. 27, Mar. 1963.
- DAVISON, G. N., see PHILLIPS, R. S.

- DILWORTH, R. A. Moving into the U.H.F. Range. *Post Office Telecommunications Journal*, Vol. 15, p. 17, Spring 1963.
- EVANS, G. O., see BRICE, P. J.
- FENNING, J. C. Detecting Unlicensed Sets. *Wireless World*, Vol. 69, p. 71, Feb. 1963.
- FORSTER, C. F., and RICKARD, E. F. Phosphorescence in Plastics. *Nature*, Vol. 197, p. 1, 199, 23 Mar. 1963.
- GLOVER, D. W., see HAYES, H. C. S.
- GRIFFITH, R. G., see BAMPTON, J. F.
- HALE, H. S., and MACDIARMID, I. F. Video Waveform Correctors for Use with Coaxial Cable. *Proceedings I.E.E.*, Vol. 110, p. 1,319, Aug. 1963.
- HALE, H. S., and MACDIARMID, I. F. Video Transmission Systems for Use with Coaxial Cable. *Proceedings I.E.E.*, Vol. 110, p. 1,329, Aug. 1963.
- HALSEY, R. J. Transatlantic Cables for Television. *British Communications and Electronics*, Vol. 10, p. 620, Aug. 1963.
- HALSEY, R. J., see BAMPTON, J. F.
- HARRIS, B. V., see LOW, A. T.
- HAWKINS, C. F. W., see HOLLINGHURST, F.
- HAYES, H. C. S. The Dover to Deal Experiment. *Post Office Telecommunications Journal*, Vol. 15, p. 34, Winter 1963.
- HAYES, H. C. S., and GLOVER, D. W. Developments in the Application of Polythene to Telecommunications Cables. *I.P.O.E.E. Printed Paper No. 220*, 1963.
- HICKSON, A. G. They Help to Put the Pictures on Your Screen. *Post Office Telecommunications Journal*, Vol. 15, p. 20, Autumn 1963.
- HOLLINGHURST, F., and HAWKINS, C. F. W. A Survey of the Development of Television Broadcast Relay in the United Kingdom. *I.E.E. Conference Report Series No. 5*. Paper No. 4,034E, p. 366, June 1963.
- HOLMES, J. N., and SHEARME, J. N. Speech Synthesis by Rule, Controlled by a Small, Low-speed, Digital Computer. *Journal of the Acoustical Society of America*, Vol. 35, No. 11, p. 1,911, Nov. 1963.
- HOWARTH, J. E. BMEWS and the Post Office. *Post Office Telecommunications Journal*, Vol. 15, p. 1, Summer 1963.
- HUGHES, C. J., and MORRIS, D. W. Phase Characteristics of H.F. Radio Waves Received after Propagation by the Ionosphere. *I.E.E. Convention on H.F. Communications*, p. 20, Mar. 1963. (*Proceedings I.E.E.*, Vol. 110, p. 1,720, Oct. 1963.)
- HUGHES, C. J., see MORRIS, D. W.
- HUTTON-PENMAN, P. R., see CREIGHTON, J. L.
- ITHELL, A. H. The Measurement of the Acoustical Input Impedance of Human Ears. *Acoustica*, Vol. 13, p. 140, Mar. 1963.
- ITHELL, A. H. A Determination of the Acoustical Input Impedance of Human Ears. *Acoustica*, Vol. 13, p. 311, April 1963.
- JEYNES, E., see THOMAS, J. F. P.
- JONES, F. A Precise Method for Measuring Dielectric Loss. *Electronic Engineering*, Vol. 36, p. 733, Nov. 1963.
- JONES, F., see BROCKBANK, R. A.
- KEEN, D. S., and SWYNNERTON, D. C. The New Post Office Speaking Clocks. *British Communications and Electronics*, Vol. 10, p. 522, July 1963.
- KEEP, J. Curing Leaks in Local Cables. *Post Office Telecommunications Journal*, Vol. 15, p. 25, Autumn 1963.
- KELLY, P. T. F., see BAMPTON, J. F.
- LAWSON, R. W. Influence of Anode Material on the Cathode Emission of Low-Voltage Valves having Passive Cathode Cores. Presented at International Symposium on Residual Gasses in Electron Tubes, Milan, Mar. 1963 (Italian Physical Society).
- LEWIS, W. J., and TUNGATE, R. G. Telephone Service in Great Britain. *Telephone Engineer and Management*, Vol. 67, p. 37, 15 Dec. 1963.
- LINKE, J. M. Some Aspects of Echo Waveform Correction and Synthesis. *I.E.E. Conference Report Series No. 5*, Paper No. 3,991E, p. 213, June 1963.
- LORD, G. W. Slitting Very Thin Cold-Rolled Metal Tapes Without Edge-Burr. *Sheet Metal Industries*, Vol. 40, p. 111, Feb. 1963.
- LORD, G. W. Measuring Water Vapour in High-Purity Gas. *Measurement and Control*, Vol. 2, p. 236, June 1963.
- LOVELESS, E. I. R., see ALLNATT, J. W.
- LOW, A. T., and HARRIS, B. V. Measurement of Rhombic Aerial Characteristics Using an Aircraft. *I.E.E. Convention on H.F. Communication*, p. 99, Mar. 1963.
- LOW, A. T., and HARRIS, B. V. Vertical Wave-Arrival Angle Measurements of H.F. Transmission During Period Dec. 1960-July 1961. *I.E.E. Convention on H.F. Communication*, p. 52, Mar. 1963.
- MACDIARMID, I. F., see HALE, H. S.
- MAY, E. J. P., see MORRIS, D. W.
- METSON, G. H. The Conductivity of Oxide Cathodes, Part 16. Thermodynamic Considerations of Matrix Stability. *Proceedings I.E.E.*, Vol. 110, No. 5, p. 845, May 1963.
- MILLS, D. E., see ALLNATT, J. W.
- MINSTER, J. T. Atmospheric Hydrogen Sulphide Concentrations During the London Fog of December 1962. *Nature*, Vol. 199, p. 474, 3 Aug. 1963.
- MITCHELL, G., see MORRIS, D. W.
- MORRIS, D. W., MITCHELL, G., MAY, E. G. P., HUGHES, C. J., and DAGLEISH, D. I. An Experimental Multiple-Direction Universally-Steerable Aerial System for H.F. Reception. *I.E.E. Convention on H.F. Communications*, p. 121, Mar. 1963 (*Proceedings I.E.E.*, Vol. 110, p. 1,569, Sept. 1963).
- MORRIS, D. W., see HUGHES, C. J.
- MUMFORD, SIR ALBERT. Communications in the Public Service of the United Kingdom. *Journal I.E.E.*, Vol. 9, p. 460, Nov. 1963.
- NEILL, T. B. M., see REYNOLDS, F. H.
- PARKER, P. N. Frequency Management in the H.F. Radio Spectrum 3-30 Mc/s. *I.E.E. Convention on H.F. Communication*, p. 397, Mar. 1963.
- PHILLIPS, R. S., and DAVISON, G. N. Mechanizing the Postal Service. *Proceedings I.Mech.E.*, Vol. 177, p. 205, Sept. 1963.

PICKARD, E. F., see FORSTER, C. F.

POOLE, P. H., see SCOWEN, F.

REYNOLDS, F. H., and NEILL, T. B. M. Theoretical Design of Frameworks for the Support of Grids of Strained Wires. *Proceedings I.E.E.*, Vol. 110, p. 1,597, Sept. 1963.

RICHARDSON, F. S., see ALLNATT, J. W.

RIDOUT, P. N., and WHEELER, L. K. Choice of Multi-Channel Telegraph Systems for Use on H.F. Radio Links. *I.E.E. Convention on H.F. Communication*, p. 153, Mar. 1963 (*Proceedings I.E.E.*, Vol. 110, p. 1,402, Aug. 1963).

SANDELL, R. S., see BRICE, P. J.

SCOWEN, F., and POOLE, P. H. Anglo-Canadian Transatlantic Telephone Cable (CANTAT) Repeater Fault Locating Equipment. *Proceedings I.E.E.*, Vol. 110, p. 1,140, July 1963.

SCOWEN, F., WALKER, D. C., and TAYLOR, S. A. Anglo-Canadian Transatlantic Telephone Cable (CANTAT)—Repeaters and Equalization. *Proceedings I.E.E.*, Vol. 110, p. 1,134, July 1963.

SEWTER, J. B., and WILLIAMS, M. B. Television Network Switching. *I.E.E. Conference Report Series No. 5*, Paper No. 3,945E, p. 223, June 1963.

SHEARME, J. N., see HOLMES, J. N.

STEPHENSON, M. Faults in Computers. *O and M Bulletin*, Vol. 18, No. 4, p. 171, Nov. 1963.

SWAFFIELD, J. Synthetic Speech. *The Times Weekly Review*, 17 Jan. 1963.

SWYNNERTON, D. C., see KEEN, D. S.

TAYLOR, F. J. D. Automatic Control of a Large Steerable Aerial for Satellite Communications. *Proceedings of the Second Congress of the International Federation of Automation and Control*, Basle, Sept. 1963.

TAYLOR, F. J. D. Communications by Satellite. *Penguin Science Survey*, 1964.

TAYLOR, F. J. D. Lasers and Masers. *Post Office Telecommunications Journal*, Vol. 15, p. 8, Summer 1963.

TAYLOR, F. J. D. Satellite System Earth Stations—Masers or Parametric Amplifiers for the First Receiving Stage? *I.E.E. Conference on the Design and Use of Microwave Valves*, Conference Digest, p. 8, Oct. 1963.

TAYLOR, F. J. D. Die Boden Station, Goonhilly Downs. *Technische Mitteilungen P.T.T.*, No. 10, p. 367, Nov. 1963.

TAYLOR, S. A., see SCOWEN, F.

THOMAS, J. F. P., and JEYNES, E. Anglo-Canadian Transatlantic Telephone Cable (CANTAT)—Power Feeding Equipment. *Proceedings I.E.E.*, Vol. 110, p. 1,146, July 1963.

THURLOW, E. W., see ALLNATT, J. W.

TILLMAN, J. R., see BAKER, D.

TUNGATE, R. G., see LEWIS, W. J.

WALKER, D. C., see SCOWEN, F.

WARD, W. C. Taking the Work out of Work. *Post Office Telecommunications Journal*, Vol. 15, p. 10, Spring 1963.

WATT-CARTER, D. E., and YOUNG, S. G. Survey of Aerials and Aerial Distribution Techniques in the H.F. Fixed Service. *I.E.E. Convention on H.F. Communication*, p. 67, Mar. 1963 (*Proceedings I.E.E.*, Vol. 110, p. 1,528, Sept. 1963).

WHEELER, L. K., see RIDOUT, P. N.

WILLIAMS, M. B., see SEWTER, J. B.

YOUNG, S. G., see WATT-CARTER, D. E.

*Mr. Sandell is with the British Broadcasting Corporation.

BOARD OF EDITORS

D. A. BARRON, C.B.E., M.Sc., M.I.E.E., Chairman.
L. F. SCANTLEBURY, Whit.Sch., A.C.G.I., D.I.C., M.I.E.E.
T. H. FLOWERS, M.B.E., B.Sc.(Eng.), M.I.E.E.
W. J. E. TOBIN, B.Sc.(Eng.), A.C.G.I., D.I.C., M.I.E.E.
E. J. MARKBY, A.M.I.E.E.
D. J. HARRIS, B.Sc.(Eng.), A.M.I.E.E.
R. F. WALDEGRAVE.
A. G. LEIGHTON, B.Sc.(Eng.), A.M.I.E.E., Managing Editor.
J. MARTIN, B.Sc.(Eng.), A.M.I.E.E., Deputy Managing Editor.
J. A. POVEY, A.M.I.E.E. } Assistant Editors.
R. A. SUDELL. }
B. FARR, A.B.I., Secretary-Treasurer.
B. CROSS, Advertisement Manager.

Copyright

The entire contents of this Journal are covered by general copyright, and special permission is necessary for reprinting long extracts, but editors are welcome to use not more than one-third of any article, provided that credit is given at the beginning or end thus: "From *The Post Office Electrical Engineers' Journal*."

The Board of Editors is not responsible for the statements made or the opinions expressed in any of the articles in this Journal, unless such statement is made specifically by the Board.

Subscriptions and Back Numbers

The Journal is published quarterly, in April, July, October and January, at 3s. per copy; the post-paid price is 4s. per copy (16s. per year) via inland mail, and 4s. 3d. (17s., or 2 dollars 75 cents Canada and U.S.A., per year) via overseas mail. Back numbers will be supplied, if available, price 3s. (4s. inland mail, 4s. 3d. overseas mail) per copy. With the exception of April and

July 1961 Journals, copies of the January 1963 and all earlier Journals are no longer available. Orders should be sent to *The Post Office Electrical Engineers' Journal*, G.P.O., 2-12 Gresham Street, London, E.C.2.

Employees of the British Post Office can obtain the Journal through local agents.

Binding

Readers can have their copies of volumes bound at a cost of 15s. by sending the complete set of parts to the local Post Office distribution agent or to *The Post Office Electrical Engineers' Journal*, G.P.O., 2-12 Gresham Street, London, E.C.2.

Remittances

Remittances should be made payable to "*The P.O.E.E. Journal*" and should be crossed "& Co."

Advertisements

All correspondence relating to advertisement space reservations, copy, proofs, etc., should be addressed to the Advertisement Manager, *The Post Office Electrical Engineers' Journal*, G.P.O., 2-12 Gresham Street, London, E.C.2.

Communications

With the exceptions indicated above, all communications should be addressed to the Managing Editor, *The Post Office Electrical Engineers' Journal*, G.P.O., 2-12 Gresham Street, London, E.C.2. Telephone: HEADquarters 1234.

Model Answer Books

Books of model answers to certain of the City and Guilds of London Institute examinations in telecommunications are published by the Board of Editors. Details of the books available are given at the end of the Supplement to the Journal.

TAKE FIVE!

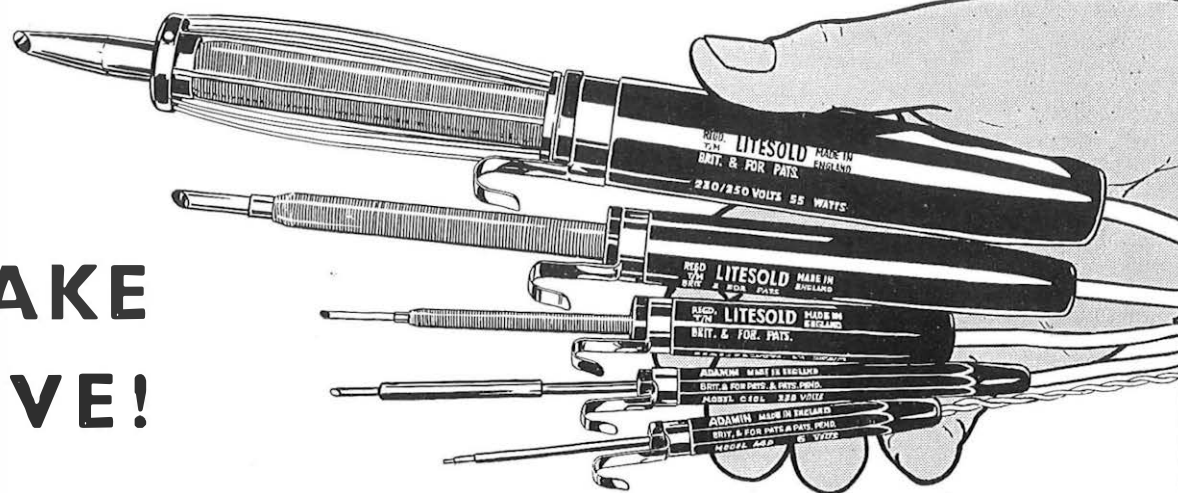

There are 30 other models, too. There **ARE** several other makes of soldering instruments. Big ones. Small ones. Good ones. We've seen them. We don't make the biggest ones. Or the most expensive ones. Or the most elaborate ones. We **DO** make the smallest ones. And the widest range. We make the best. Always have. May we send you details?

Brochure P.O. 34 post free on request

LIGHT SOLDERING DEVELOPMENTS LTD., 28 Sydenham Road, Croydon, Surrey. Tel.: CRO 8589

OXLEY

PRINTED CIRCUIT SOCKETS

The OXLEY printed circuit sockets are designed for direct mounting on .1" module printed circuit board with standard .05" minimum diameter holes, and accepts our standard plug Type 50P/156. The mounting is arranged so that the plugs may be inserted in a plane parallel to the printed circuit board thus permitting close stacking of circuit boards. Sockets can be supplied from 1 to 12 ways, colours can be in black, brown, red, orange, yellow, green, blue, violet, pink, grey and white.

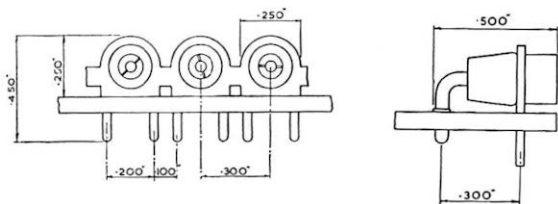
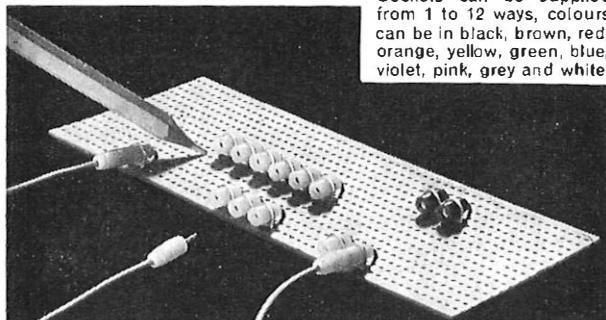

Write for technical details of these and other Oxley products

OXLEY DEVELOPMENTS CO. LIMITED
ULVERSTON, LANCASHIRE, Tel: Ulverston 2567

MODEL ANSWER BOOKS

CITY AND GUILDS OF LONDON INSTITUTE
TELECOMMUNICATION TECHNICIANS' COURSE

**TELECOMMUNICATION
PRINCIPLES A**

**TELECOMMUNICATION
PRINCIPLES B**

**ELEMENTARY
TELECOMMUNICATION
PRACTICE**

Price 7s. 6d. each. Post Paid 8s.

The following model answer book, although published for the old Telecommunications Engineering Course, is still useful and is offered at a considerably reduced price.

TELEPHONE EXCHANGE SYSTEMS I
(Telephony and Telegraphy A, Telephony B)

Price 2s. each. Post Paid 2s. 6d.

Orders to

The Post Office Electrical Engineers' Journal
G.P.O., 2-12 Gresham Street, London, E.C.2

* "Celcurised"

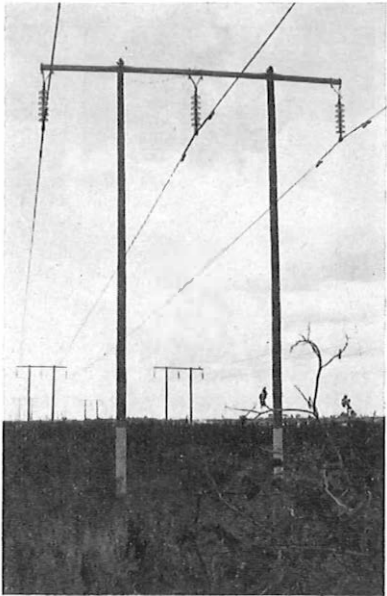

POLES,

East Africa Power & Lighting Co. of Nairobi have been treating all poles and cross arms for their transmission lines with Celcure for over 10 years. The illustration shows the 66 kV ring main around Nairobi carried on Pilkington glass discs mounted on "Celcurised" cross arms and double poles.

* "Celcurised" timber which has been correctly vacuum/pressure impregnated with Celcure wood preservative to afford lasting protection against fungal decay and insect attack and/or termites.

DRUMS

The failure of a loaded cable drum wherever it may be is a highly expensive and troublesome problem. In fact, if the site of the failure is sufficiently remote, it can mean the complete loss of valuable cable and perhaps necessitate replacement from the other side of the world. Even the continual replacement of returnable drums, through decay, is a costly practice.

At General Woodworkers Ltd., Penn, Buckinghamshire, virtually all their drums are Celcure treated. The photograph illustrates a 10 ft. diameter drum with the vacuum/pressure impregnation plant in the background and smaller drum flanges being wheeled to the pressure cylinder for loading. Appropriate treatment with Celcure affords lasting protection against decay and termite attack. The G.P.O. now specify vacuum/pressure impregnation for all their drums.

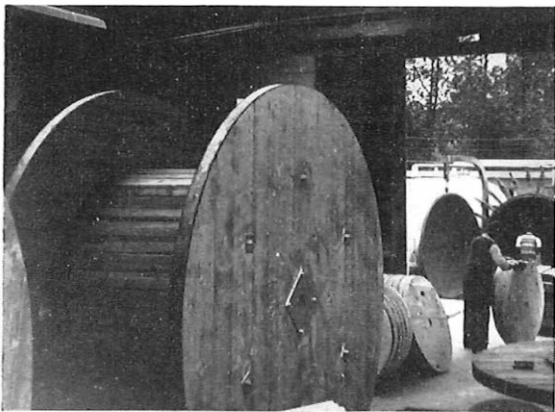

and more POLES

Australian hardwood poles emerging from the pressure cylinder after impregnation with Celcure 'A' wood preservative. *"Celcurised" transmission poles are being increasingly employed in Australia and it was with this in view that Brandon Timbers Ltd., established a Celcure plant at their pole yard in Queensland. The treatment cylinder which is seen in the photograph is 85' long x 6' diameter.

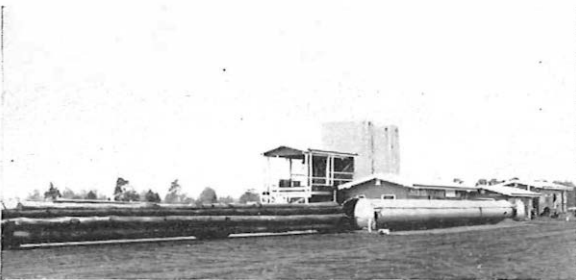

Extracts from The "Celcure" Bulletin



For free details of "Celcurised" timber for particular purposes and regular receipt of The Celcure Bulletin, please complete and return the coupon today.

Name

Company

Address

For England, Wales and Overseas:
Celcure Ltd., Kingsway House,
Kingsway, London, W.C.2
Tel.: CHAncery 8325

For Scotland and Northern Ireland:
Celcure & Chemical Co. Ltd.,
300 Bearsden Road, Glasgow, W.3
Tel.: Jordanhill 8021

G.E.C. TELEPHONES



G.E.C.
706 telephone
a general purpose table instrument.

**FOR
EVERY
APPLICATION**

G.E.C. also produces intercommunication sets, loudspeaking telephones and telephones for special applications for ships, railways, mines etc.

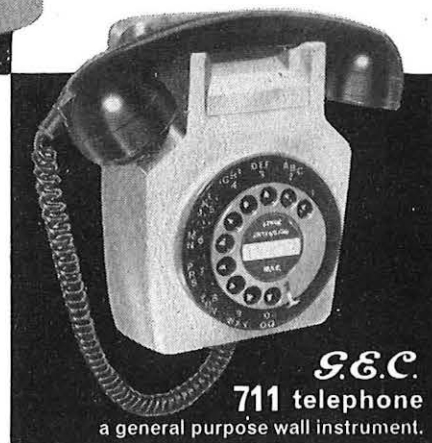

G.E.C.
711 telephone
a general purpose wall instrument.



G.E.C.
710 telephone
for plan and extension systems
and special facilities.



G.E.C.
**switching
telephone**
for plan 105 and
plan 107 operation.

Telephone Division

G.E.C. (TELECOMMUNICATIONS) LIMITED • TELEPHONE WORKS • COVENTRY • ENGLAND

Works at Coventry, Middlesbrough and Treforest

Smec's 168.

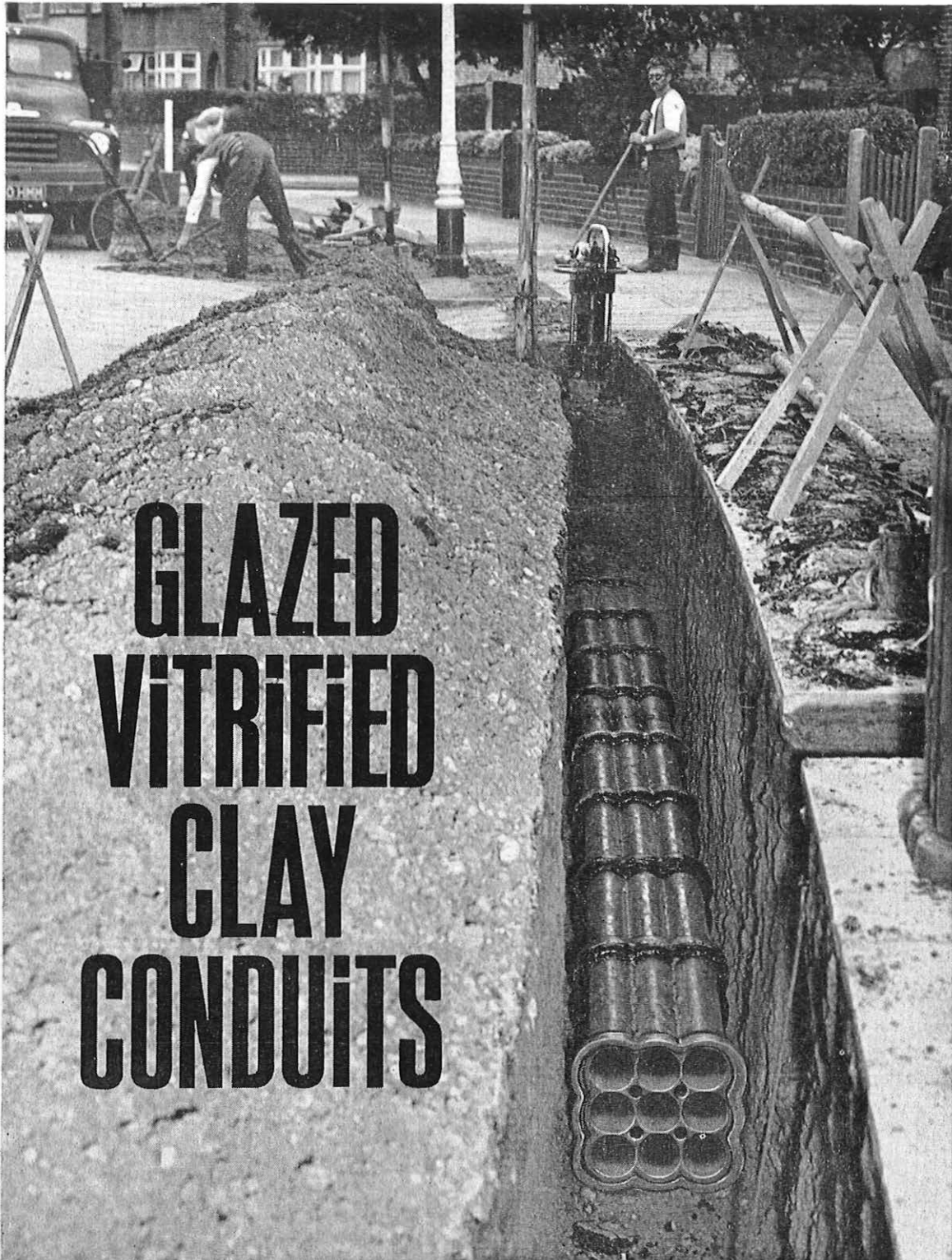

GLAZED VITRIFIED CLAY CONDUITS

*Photograph by courtesy of
H.M. Postmaster General.*

... for underground security

Our telecommunications, lighting systems and power lines are vital.
For permanence, how right to use **glazed vitrified clay conduits**
... there is no adequate substitute.

write for further information to the Engineer

NATIONAL SALT GLAZED PIPE MANUFACTURERS' ASSOCIATION
125 New Bond Street, London W.1
Telephone: **MAYfair 2763-4**



type 174

small diameter coaxial cable specially designed for use with transistor amplifiers

Small diameter coaxial cables have now become an established medium for the provision of long distance high grade telephone circuits. Coupled with underground transistorised amplifiers, this type of cable is rapidly finding increased use amongst telephone administrations throughout the world as the most economical method of providing groups of trunk telephone circuits.

Telephone Cables Limited have developed their own design of small diameter .174 Coaxial Tube to meet the recommendations of the C.C.I.T.T. and the requirements of the British Post Office. The cable has been fully tested and approved by the British Post Office and cables of this design, manufactured and installed by T.C.L., are now in hand for supply and installation in the United Kingdom and overseas.

*Fullest technical details of
Type 174 Coaxial Cable gladly supplied by return.*



TCL

TELEPHONE CABLES LIMITED

Dagenham, England Tel: Dominion 6611 Cables: Drycore Dagenham

THE ORGANISATION WITH 125 YEARS' EXPERIENCE



**LOW LINE
STYLING**

**CHOICE OF
EXTERNAL
FINISHES**

**RETRACTABLE
KEYSHELF**

**HIGHLY
VERSATILE**

**CAPACITY
UP TO
200 LINES**

T.M.C. FLOOR PATTERN SWITCHBOARD

“A thing of beauty”

Leading industrial designers, top circuit engineers, and a production team with years of accumulated switchboard experience have worked together to evolve this superb TMC switchboard. The result is a product which in appearance and performance will fulfil the needs of many years to come. It will blend with the decor of the most modern office or reception hall. It is highly adaptable and can be variously equipped, as a multiple or non-multiple. This switchboard will serve subscribers, operators and engineers throughout a long working life—and serve them well.

TMC

TELEPHONE MANUFACTURING COMPANY LIMITED

Telephone Equipment Division • Public Equipment Unit • Martell Road
West Dulwich • London • S.E.21 • Telephone GIPsy Hill 2211 • Telex 28115

A MEMBER OF THE  GROUP OF COMPANIES

SPACE FOR PRESTIGE . . .

**BUT
CABLES
FOR SURE COMMUNICATIONS**

**SUBMARINE
CABLES LTD**

GREENWICH · LONDON · SE10 OWNED JOINTLY BY AEI AND BICC

With the environment of space beyond the control of man, only submarine telephone cables can provide intercontinental communications of proven reliability, economy and freedom from interference. Submarine Cables Ltd. can supply cable, repeaters, cable-laying gear and services, and—through AEI—terminal equipment.

**SUBMARINE
CABLES LTD**

GREENWICH · LONDON · SE10 OWNED JOINTLY BY AEI AND BICC

THE MARCONI HU126

**SELF CONTAINED
7-UNIT MONITOR
PROVIDES
MONITORING OF
ARQ AGGREGATE
SIGNALS*
INDEPENDENTLY OF
THE ARQ TERMINAL**

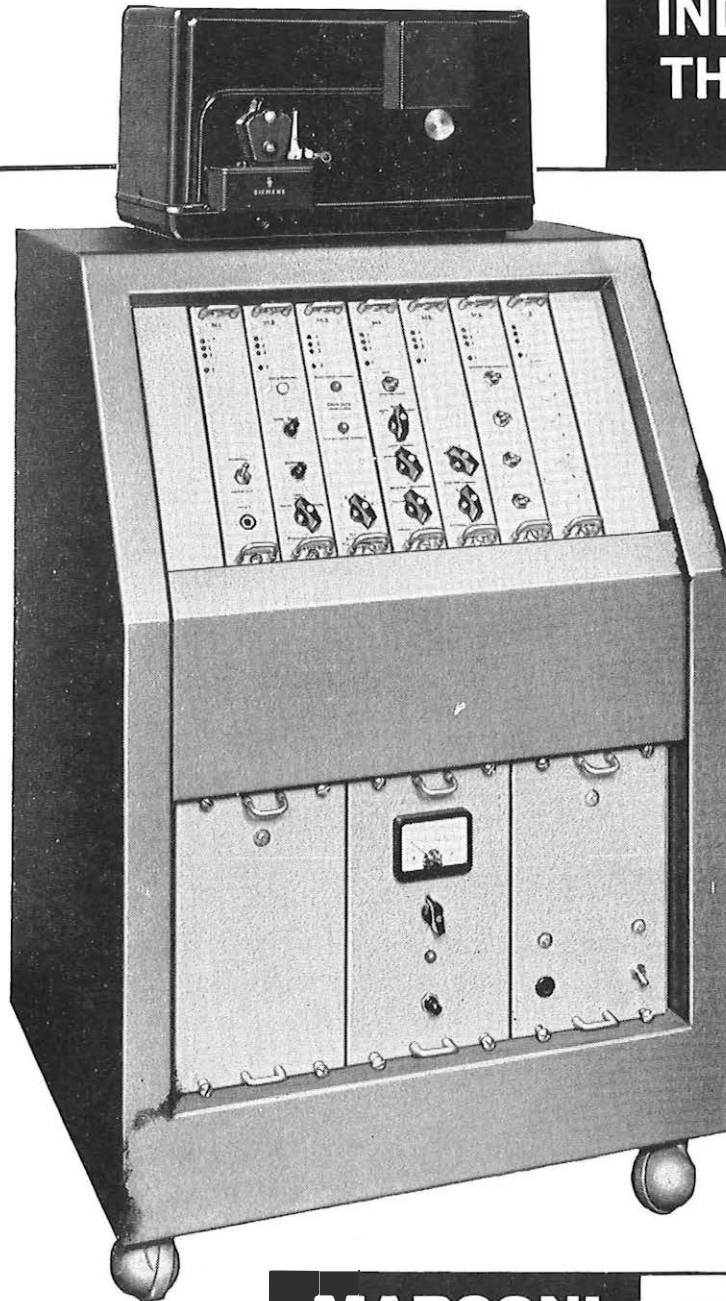

- Automatic phasing
- Self-synchronizing
- Printed record of any channel or any sub-channel.

The HU126, an item in the Marconi AUTOPLEX range of error correcting multiplex telegraph equipment, is Ferritransistorized and uses modular construction. Being a self-contained unit with its own power supplies and crystal oscillator, it can be used with any type of ARQ equipment* and quite independently of the ARQ terminals.

* in accordance with CCIR
Recommendation No. 242 and/or Report No. 108
(Los Angeles 1959)

MARCONI

TELECOMMUNICATIONS SYSTEMS

COMMUNICATIONS DIVISION THE MARCONI COMPANY LIMITED, CHELMSFORD, ESSEX, ENGLAND

111



Telecommunications is people talking . . .

. . . and A.T.E. have been talking communications for over half a century. In that time A.T.E. has grown from the small nucleus organisation that pioneered the Strowger system of automatic telephony in the United Kingdom to a world-wide network of companies — the largest manufacturers of telecommunications equipment in the British Commonwealth.

In the U.K. alone, the Company has one and a half million square feet of production space at its



across the world

disposal whilst, overseas, there are associated factories in Australia, New Zealand, South Africa, Portugal and Brazil.

The whole of the Company's research and development programme is centrally co-ordinated and the resultant cross-fertilisation of ideas and information is one of the main reasons why A.T.E. telecommunications equipment is the most advanced in the world.



8 ARUNDEL STREET · LONDON WC2 · *A Principal Operating Company of the Plessey Group*



The world's most competitive Single Sideband Radiotelephone—the SSB 125 is suitable for fixed or mobile operation and is the most economic equipment for long distance communication available today.

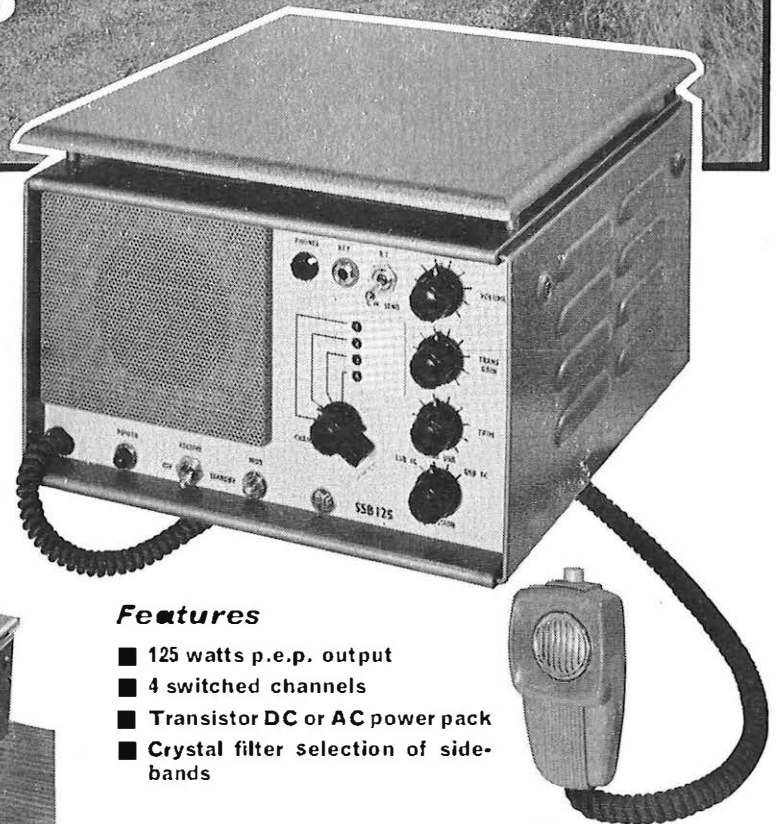

Features

- 125 watts p.e.p. output
- 4 switched channels
- Transistor DC or AC power pack
- Crystal filter selection of sidebands

PYE TELECOMMUNICATIONS LTD.
CAMBRIDGE · ENGLAND
 Telephone: Teversham 3131

wide band matching transformers

complete reliability from -20°C to $+55^{\circ}\text{C}$



Users of h.f. equipment, from the Arctic to the Persian Gulf, look for aerial matching transformers of exceptional reliability under widely varying climatic conditions.

MEL use special low-loss ferrite cores to produce 1kW, 2kW and 5kW transformers with a frequency range from 1.5 to 30 Mc/s. Impedance ratios of 600 ohms balanced to 75/60/50 ohms unbalanced are available.

These transformers are of compact design, rugged construction and completely weatherproof, offering the full specification over the temperature range -20°C to $+55^{\circ}\text{C}$.

The power ratings of the MEL transformers can be increased if a limited frequency or temperature range is acceptable.

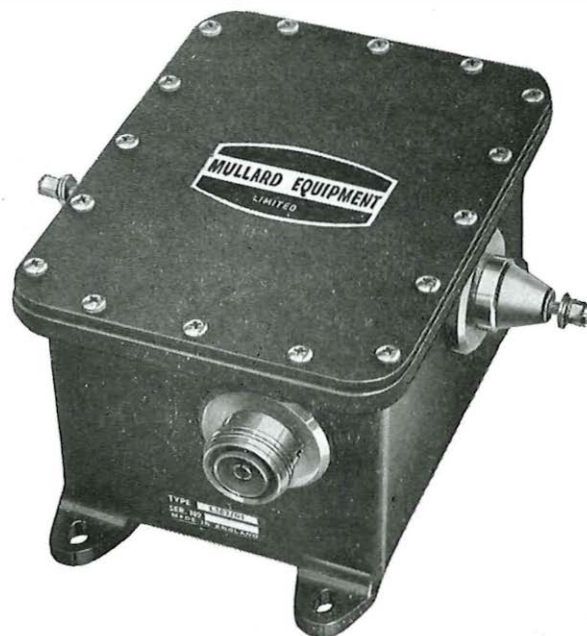

Please write for further technical details and Data Sheets to:

MULLARD EQUIPMENT LIMITED

Manor Royal · Crawley · Sussex · Telephone: Crawley 28787

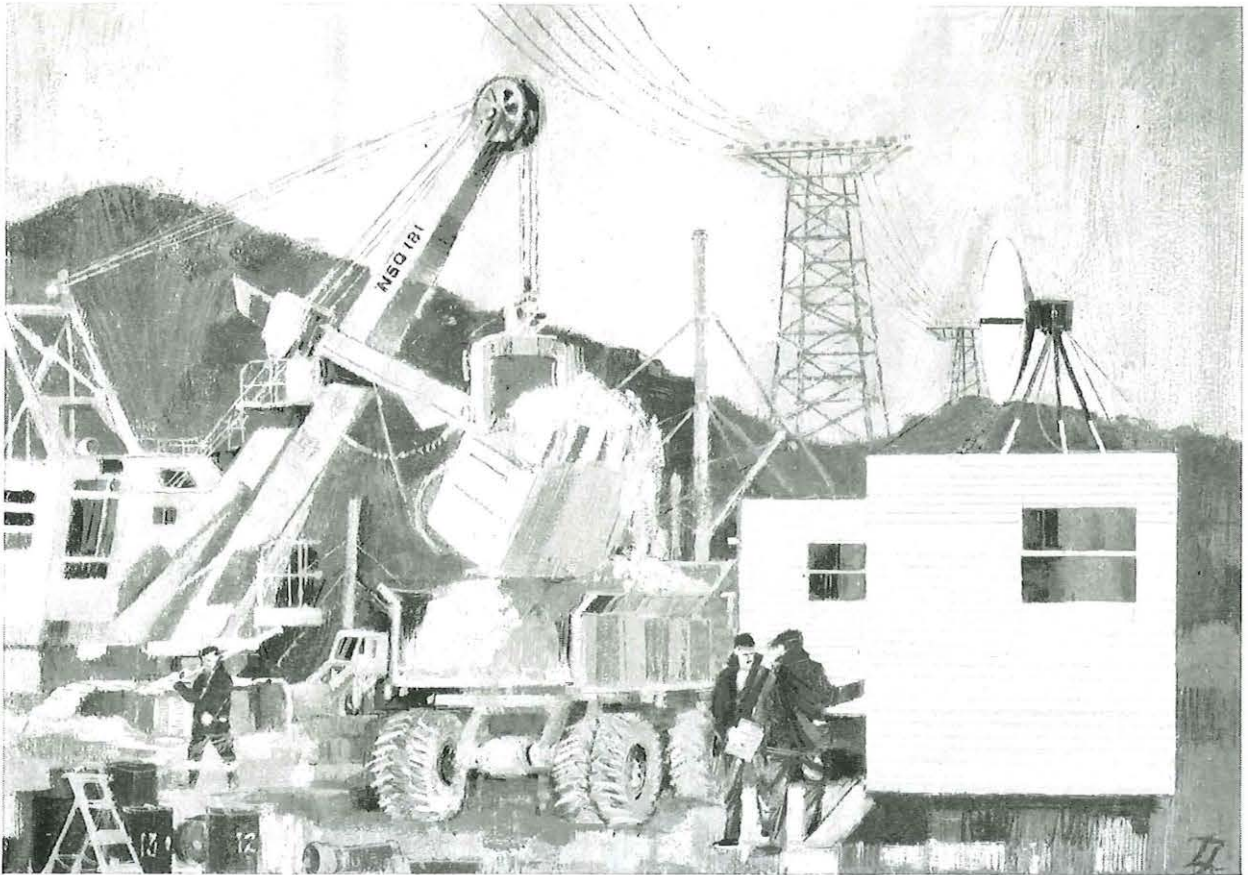

ALL TRANSISTOR 4-CIRCUIT TELEPHONE CHANNELLING A compact self-contained channelling equipment for use with VHF or SHF radio links or cables. This robust equipment, housed in a waterproof box, is designed for operation in any climate. It is suitable for providing emergency telephone service or temporary service to large engineering projects. □ Four telephone circuits and engineering speaker circuit within 0.3-20 kc/s band □ Inbuilt signalling □ Built-in test facilities and loudspeaker □ Total weight 80 lb (36 kg) □ Battery power consumption 10 watts. Write, 'phone or Telex for full details: Standard Telephones and Cables Limited, Transmission Systems Group, North Woolwich, E.16. Telephone ALBert Dock 1401. Telex 21645.

world-wide telecommunications and electronics

STC

BALANCED CABLE MULTIPLEX

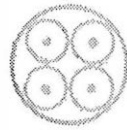
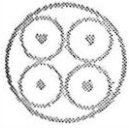

Ericsson ETC 601 systems are now in operation in various parts of the world under very diverse climatic conditions. Diagrammatically illustrated is the cable route of an ETC 601 system at present operating between Sault Ste. Marie, Wawa, and Hearst in Northern Ontario, Canada.

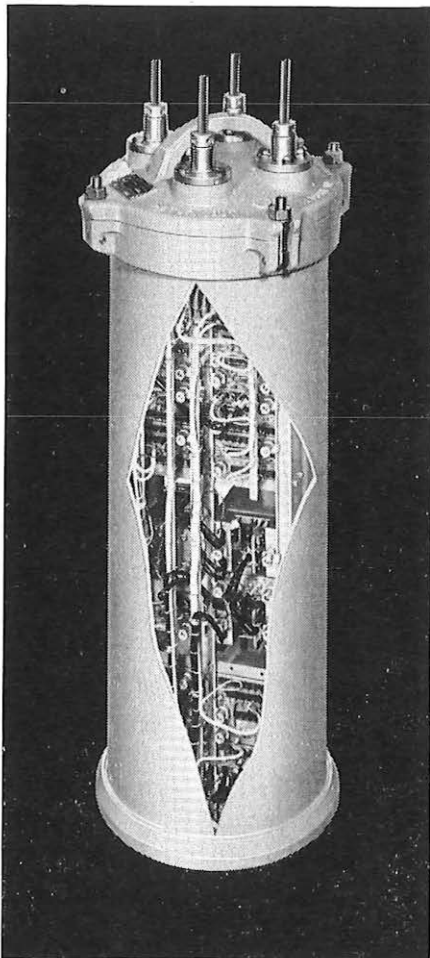

The fully transistorised system, including power-fed buried repeaters gives 120 telephone circuits in the band 12-252 kc/s with facilities for dropping circuits from either direction at all main repeaters.

It is primarily designed to operate over two 40 lb. single quad polythene cables which may be ploughed into the ground easily and cheaply, although where the terrain prohibits this the cables may be slung overhead for short distances.

Ericsson manufacture an extensive range of transmission equipment including channelling for use over radio, open wire, or cable, and are well equipped for planning and provisioning of extensive communication schemes.

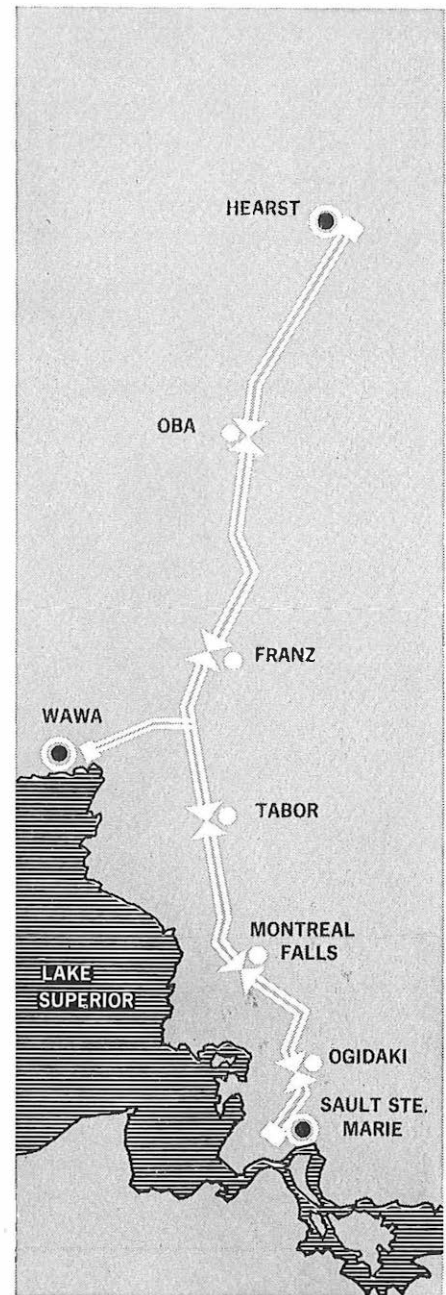

ERICSSON TELEPHONES LIMITED
ETELCO LIMITED



Caribbean Carrier

Forget the bananas and the sun-drenched sands; the coral seas and the wrecks of Spanish treasure-ships. Jamaica is now the commercial hub of the Caribbean world, and soon to be the vitally important transit centre for the Commonwealth-USA-South America communications network.

In Readiness for this tremendous development in telecommunications, the Jamaican Telephone Company have chosen ATE Type CM multiplex equipment for channelling on to the existing Kingston-Montego Bay link.

Getting Away altogether from conventional design, ATE have succeeded brilliantly in producing a compact, fully reliable carrier which is *only one-third the weight* of an equivalent valve equipment, and *saves up to 90% of the power normally used.*

The Secret? The card-mounted printed circuit of advanced design.

Jamaican Telephone is only one of the leading organizations throughout the world which have chosen ATE Type CM Carrier Equipment for microwave, open-wire and cable carrier communications.

Fully transistorized/Plug-in printed circuits/Mains or battery operation/Optional in-built out-band 3825 c/s low or high level signalling for ringdown or dialling/Suitable for extension to existing valve equipment/One-third the size of an equivalent valve unit. **Automatic Telephone & Electric Co. Ltd. 8 Arundel St. London WC2 Tel: Temple Bar 9262**



PLESSEY



GROUP

**TYPE
CM
CARRIER**

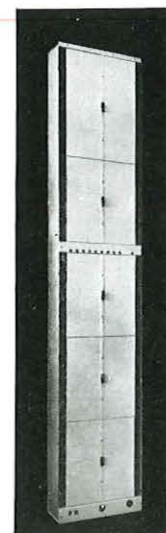
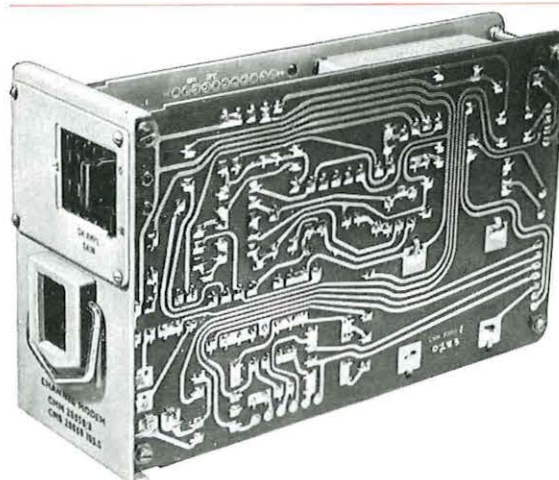

and **Now-**
a Fully Transistorised
Walkie-Talkie!



Bantam
 TWO-WAY RADIOTELEPHONE



*Once again in
 the tradition of
 the outstanding
 Cambridge and
 Vanguard Radio-
 telephones, Pye
 have produced the
 Bantam, a brilliant
 fully transistorised
 Walkie-Talkie.*

- Fully transistorised Transmitter and Receiver
- Long endurance with Rechargeable or Dry Batteries
- Reliability and accessibility of components
- Lightweight 4 lbs. (1.82 kg.)
- Crystal Filter selectivity
- Very high performance Receiver
- Frequency Band 25-174 Mc/s.
- Weatherproof

PYE TELECOMMUNICATIONS LTD. CAMBRIDGE, ENGLAND • Telex No. 81166

ADCOLA SOLDIERING INSTRUMENTS
PRODUCTS LIMITED
 (Regd Trade Mark)

FOR
 TOTAL EFFICIENCY

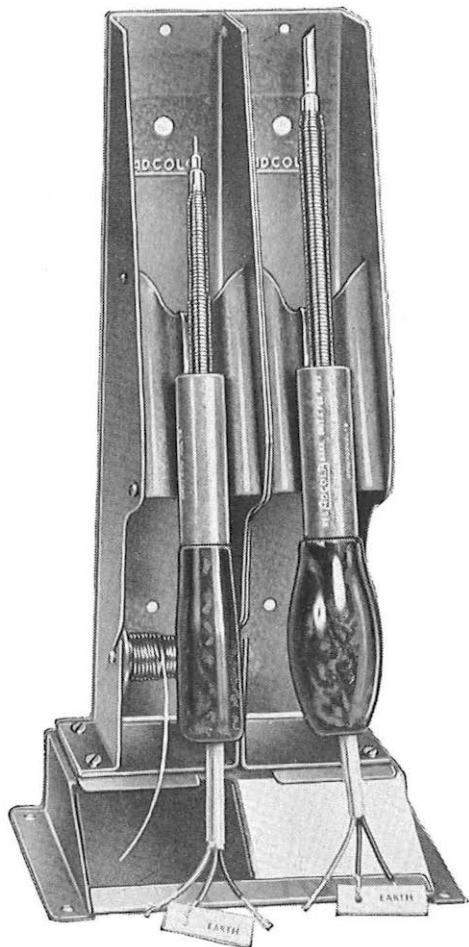

FOR CATALOGUES APPLY DIRECT TO SALES DEPT.

ADCOLA PRODUCTS LTD.

ADCOLA HOUSE

GAUDEN ROAD

LONDON, S.W.4

Telephone: MACAULAY 4272 & 3101

Telegrams: SOLJOINT, LONDON S.W.4

WHITELEY

Epoxy Resin Mouldings

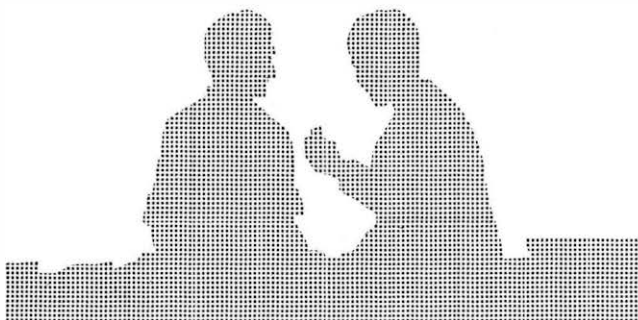

Great mechanical strength, excellent electrical insulation and complete climatic protection are ensured in Whiteley Epoxy Resin mouldings. Low shrinkage and strong adhesion to components and leads renders these Resins particularly suitable for encapsulation. Full details will be gladly sent on request.

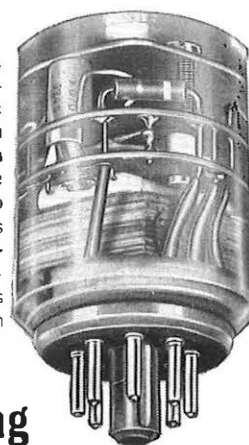

Line Isolating Transformer

Transformer Y.17525 is a low loss audio frequency transformer, for use as an isolating transformer on circuits employing 17 c/s signalling, i.e. Post Office telephones. The insulation of the 'line' winding provides isolation against voltage surges of up to 25 KV rms. and continuously applied voltages of 14 KV rms. Please write for full details.

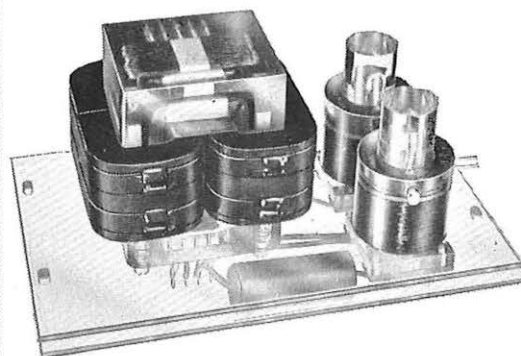

WHITELEY ELECTRICAL RADIO CO LTD

MANSFIELD · NOTTS Tel: Mansfield 1762/5

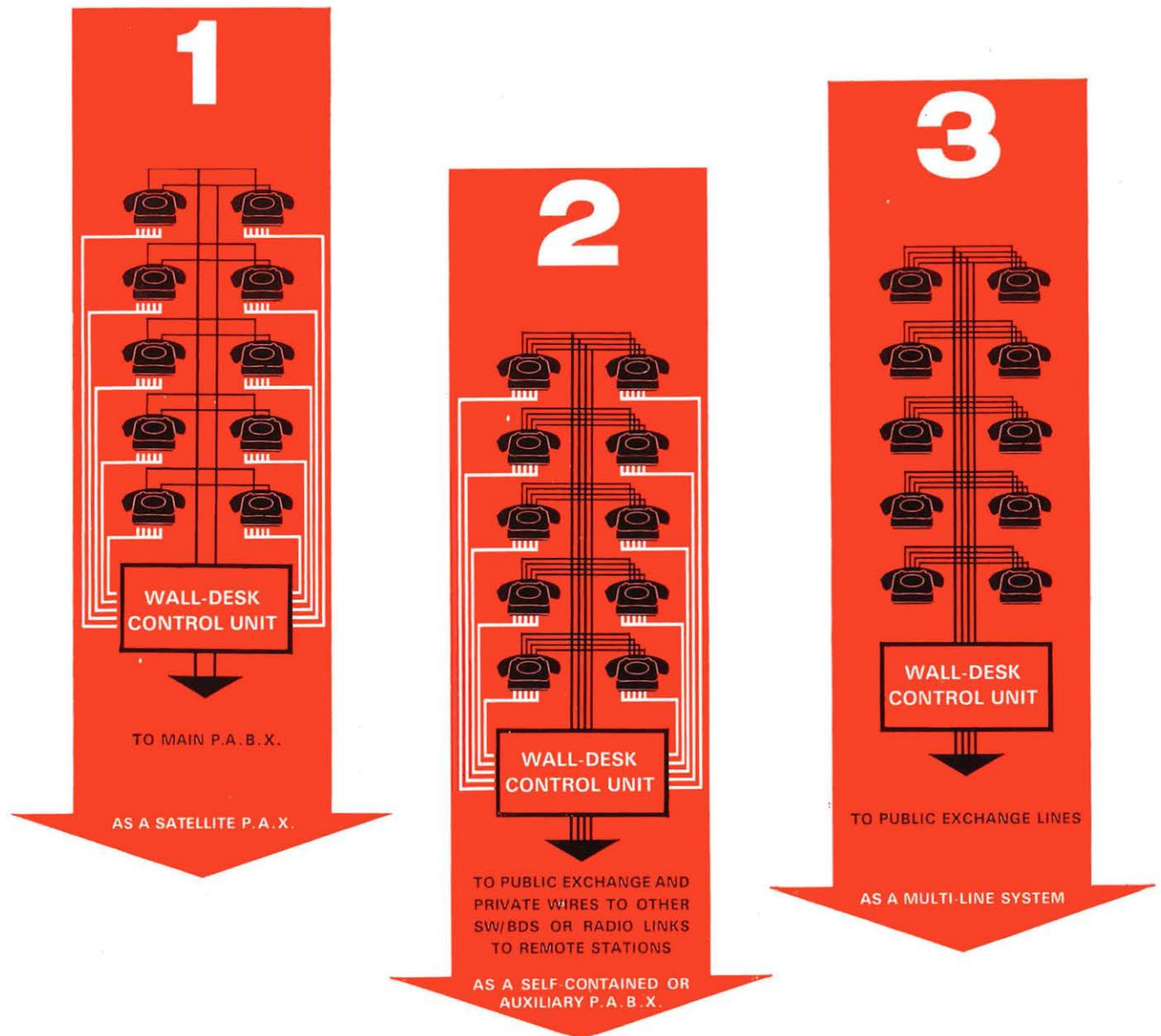

MULTIPHONE

Makes a triple attack on telecommunications problems

'Multiphone', as its name suggests, is capable of a multiplicity of applications. Serving up to 10 telephones of Plan-Etelphone type, it can be conveniently arranged by adjustment in number of circuit modules to function as a 4-line PABX, PAX or multi-line system. Its value to all administrations is increased further by its ability to work over a diversity of external circuits, so permitting a preferred arrangement to be connected as requirements demand.

Main Operational Features

- Single-digit dialling of internal calls.
- Lamp signalling and supervision of all calls signalled, held or in progress.
- Internal calls made secret or non-secret by simple strap adjustment.
- Exchange-line exclusion feature for selected stations.
- Power unit operation and continuing exchange-line service during mains failure.

For further information please apply to:—



ERICSSON TELEPHONES LIMITED
ETELCO LIMITED

A Principal Operating Company of the Plessey Group

Registered Office: 22 LINCOLN'S INN FIELDS · LONDON WC2 · Telephone HOLborn 6936



Klystron Power Unit

For use with low voltage klystrons requiring resonator-cathode supplies of 250-400 volts and resonator-reflector supplies of up to 750 volts.

D.C. heater supply adjustable between 2 and 8 volts at up to 1.5 amps. Internal circuits for sweep modulation of reflector voltage and square-wave modulation of cathode voltage.



V.S.W.R. Indicator/ Selective Amplifier Broad band operation from 800 c/s to 3500 c/s, selective at 1000 c/s and 3000 c/s. Two crystal inputs which can be used for bridge measurements. Bolometer operation from a built-in bias supply. Sensitivity better than $1\mu\text{V f.s.d.}$ Operates from mains supply or internal batteries.

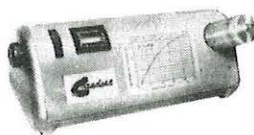

Co-axial Line Oscillators

Elimination of backlash from the cavity tuning mechanism ensures an exceptionally high reset accuracy. Three models cover the frequency range 2-12 k Mc/s.

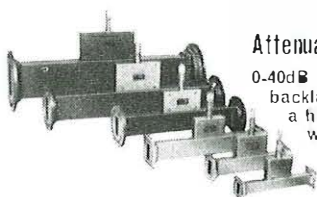

Attenuators

0.40dB glass attenuator vanes with anti-backlash micrometer adjustment giving a high setting accuracy. Available in waveguide sizes W.G. 10-22.

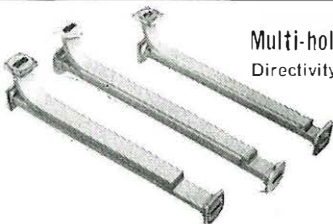

Multi-hole Couplers

Directivity better than 40dB over full waveguide frequency range. Mean coupling accuracy within $\pm 0.3\text{dB}$ V.S.W.R. better than 1.03:1 in main arm, 1.1:1 in side arm. Available for 3, 10 or 20dB coupling in waveguide sizes W.G. 12-22.



Short Matched Terminations

Compact terminating elements with a V.S.W.R. of less than 1.01:1 over the full waveguide frequency range. Power handling capacity of 2 to 10 watts mean, depending on waveguide size. Available in waveguide sizes W.G. 10-18.



Bends, Twists, Junctions

Standard items are available in most waveguide sizes. Specials can be manufactured quickly and accurately to Customers specification.



Universal Standing Wave Detector

One probe carriage is used with a series of slotted sections in waveguide sizes W.G. 10, 12, 14, 15 and 16. The position of the probe can be read to within 0.01 m.m. enabling impedance measurements to be made within 0.5%.

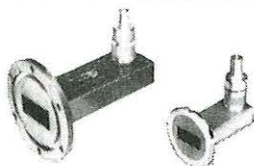

Bolometer Mounts

V.S.W.R. of better than 1.5:1 over the full waveguide frequency range. Available in waveguide sizes W.G. 10-22. Single element units are illustrated, dual element mounts for temperature compensation are also available.



Power Meter

Measures from 1 Micro-watt to 10 milli-watts to an accuracy of $\pm 3\%$. Suitable for use with most types of bolometer and thermistors. Temperature compensation facilities are built-in. Powered from mains or internal batteries.

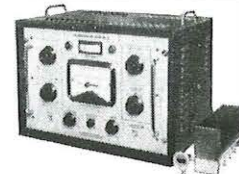

Calibration Receiver

A high gain receiver with a separate waveguide-mounting crystal mixer and head amplifier. The receiver operates at a centre-frequency of 45 Mc/s to take advantage of the low noise level of mixer diodes at this frequency. 100dB I.F., attenuator.

MICRO WAVE

Sanders

For many years, Sanders have been leaders in the British microwave field. Every Sanders instrument is the product of intensive research and development, backed by exceptionally high manufacturing standards.

Your enquiries on all aspects of Microwave Instrumentation are invited.

W. H. Sanders (Electronics) Limited.
Gunnels Wood Road · Stevenage · Herts.
Telephone: Stevenage 981

The Top Name in Europe for Microwave —

SANDERS

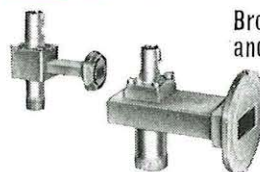

Broad Band Crystal Mixers and Detectors

V.S.W.R. better than 2:1 over full waveguide frequency range. Capacitance between centre pin and body is less than 10 pF. Available in waveguide sizes W.G. 16, 18 and 22.

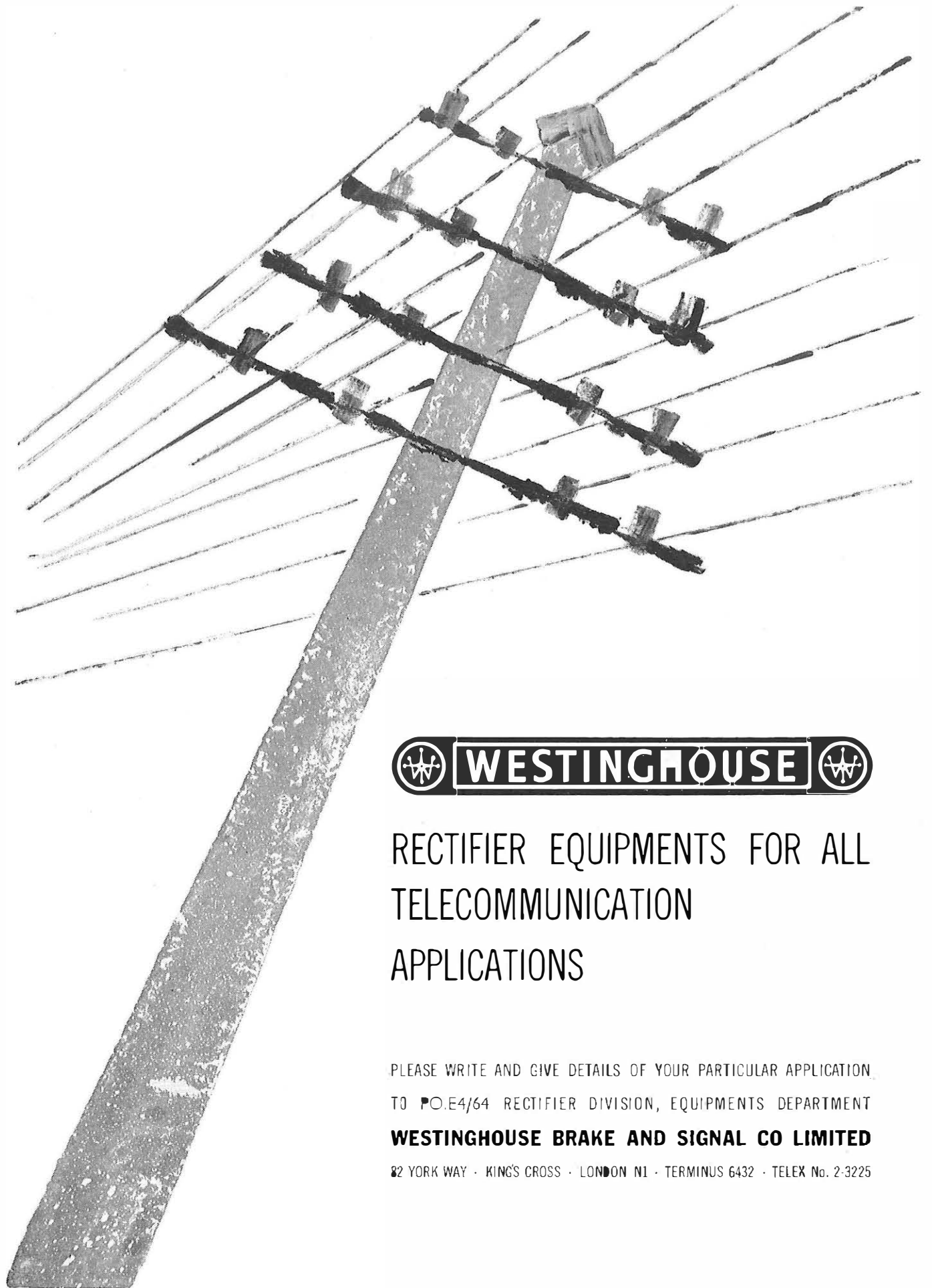

RECTIFIER EQUIPMENTS FOR ALL
TELECOMMUNICATION
APPLICATIONS

PLEASE WRITE AND GIVE DETAILS OF YOUR PARTICULAR APPLICATION
TO P.O.E4/64 RECTIFIER DIVISION, EQUIPMENTS DEPARTMENT
WESTINGHOUSE BRAKE AND SIGNAL CO LIMITED
82 YORK WAY · KING'S CROSS · LONDON N1 · TERMINUS 6432 · TELEX No. 2-3225

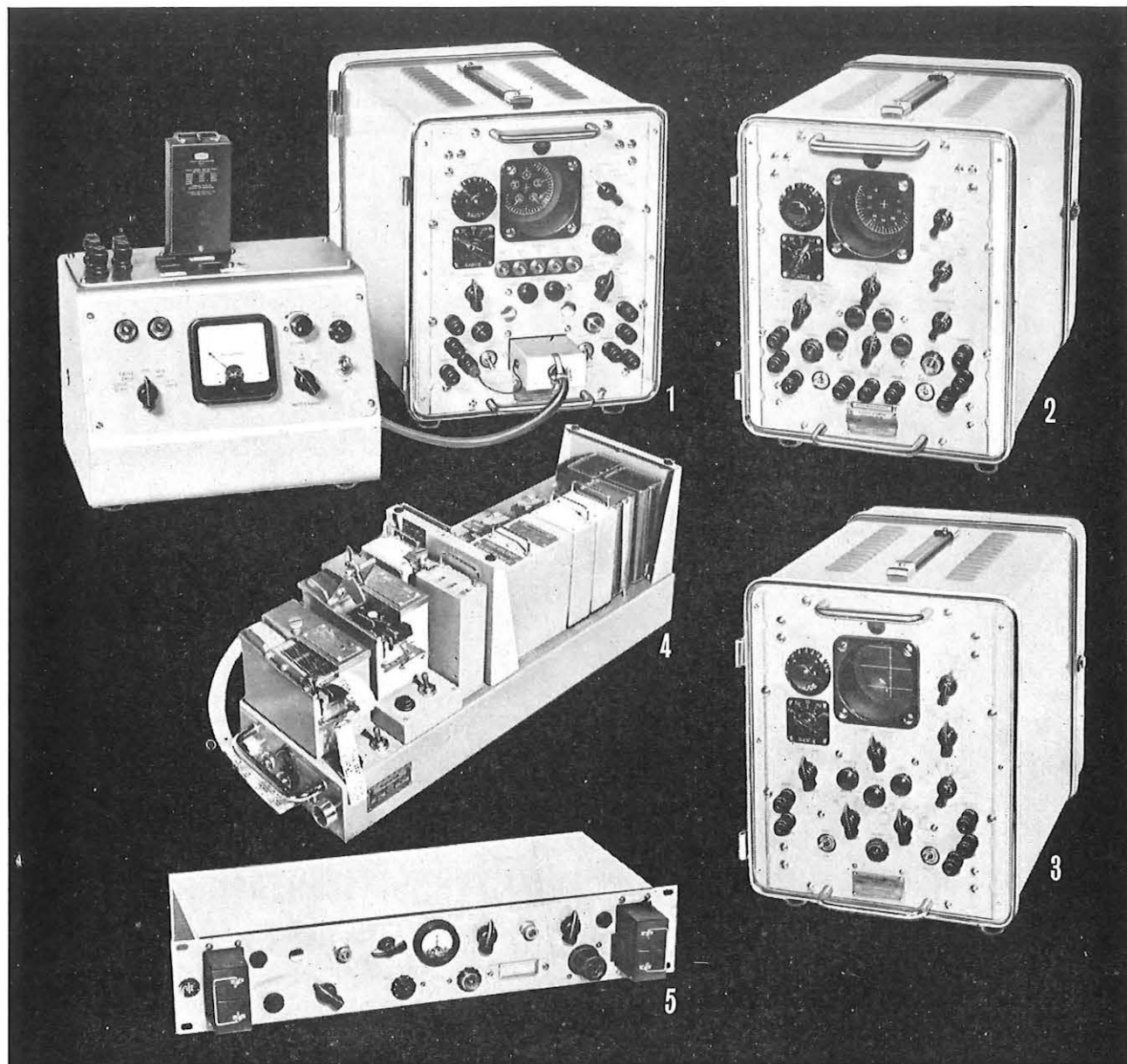

TELEGRAPH EQUIPMENT—FOR TRANSMITTING AND TESTING

ATE equipment for telegraph transmission and test purposes is in use all over the world — and not by chance. First, AT & E had to prove itself — which is why, today, ATE equipment is chosen by Postal, Military, Airline, Railway and other authorities. By all large users of telegraph systems, in fact. It is the comprehensiveness, no less than the outstanding technical quality of ATE Telegraph Equipment, which has given it this world-wide reputation. Within the range of ATE Telegraph Equipment, the various units include: 1. Telegraph Distortion Measuring Transmitter with Relay Test Adaptor 2. Distortion Measuring Receiver 3. Telegraph Signal Display 4. Tape-reader Auto-number Sender and 5. Transistorised Synchronous Regenerative Repeater. We will gladly supply details.

Please write to: A T & E (BRIDGNORTH) LIMITED · Bridgnorth · Shropshire · England

Automatic Telephone & Electric Company Limited · A Principal Operating Company of the Plessey Group



RL6B MICROWAVE RADIO LINK

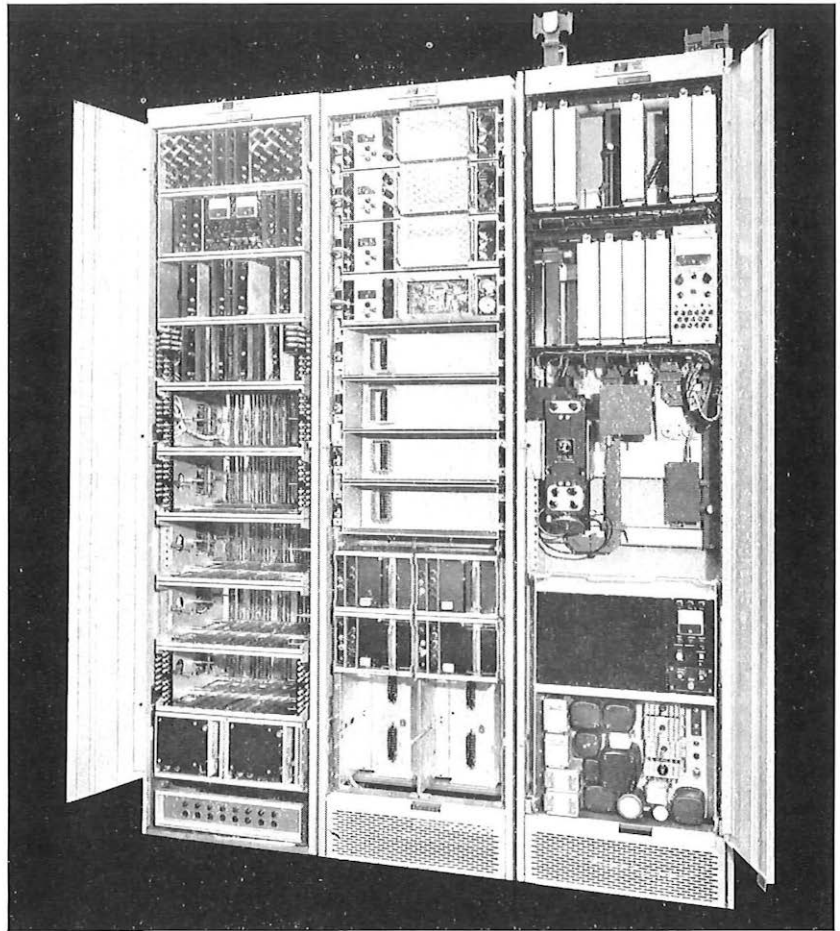

1800 TELEPHONE CIRCUITS/MAXIMUM TRANSISTORIZATION A new 6Gc/s microwave transmission system, the RL6-B, can transmit 1800 telephone channels or colour T.V. plus sound per radio channel. Designed to use the C.C.I.R. frequency plan, it will provide up to 8 broadband radio channels on one route. Maximum use of transistors, high performance level, and all-round operational economy are the essential features of the RL6-B. By extensive prefabrication, and simplification of space and installation requirements, considerable savings in commissioning time and a lower overall cost have been achieved. Systems for mains and battery operation can be supplied and a 960 telephone circuit version is also available for lower density traffic routes. The main features of the RL6-B system are: 8 broadband radio channels C.C.I.R. performance 10 watt output power from periodic permanent magnet focusing TWT Transistorized throughout except TWA and the modem cubicle 960 telephone circuit version also available Switching systems available for N + 1 or 2 protection channels Aerials and towers can be supplied All solid state narrow-band auxiliary link Cassegrain antenna for single or bi-polar operation. Write, 'phone or Telex to: Standard Telephones and Cables Limited, Transmission Systems Group, North Woolwich, London, E.16. Telephone ALBERT Dock 1401. Telex 21645.

world-wide telecommunications and electronics **STC**



SMALL DIAMETER COAXIAL CABLE LINE EQUIPMENT

This equipment has been ordered by the G.P.O.
for the following routes: —

BIRMINGHAM — WOLVERHAMPTON
DONCASTER — LINCOLN
LEEDS — YORK
HEREFORD — WORCESTER
BLACKPOOL — PRESTON
CHATHAM — LONDON
SLOUGH — LONDON

- ★ The equipment is completely transistored.
- ★ Conveys 300 high quality speech circuits, in the frequency band 60kc/s to 1300kc/s, over a pair of 0.174in. coaxial tubes.
- ★ A complete terminal is contained in a rack 9ft. high, 20½in wide and 8½in deep.
- ★ Repeaters are either power fed and contained in watertight boxes for burial in the ground or installation in underground cable manholes or, mounted on racks of the same dimensions as the terminal equipments, with or without power feeding panels, for installation in a repeater hut or equipment room.
- ★ Each power fed repeater is equipped with supervisory facilities to enable the associated power feeding terminal or repeater station to determine at which power fed repeater a fault has occurred.



Everything for Telecommunications

Transmission Division

G.E.C. (TELECOMMUNICATIONS) LTD · TELEPHONE WORKS · COVENTRY · ENGLAND

Works at : Coventry · Middlesbrough and Treforest

Since 1872

62 TYPE

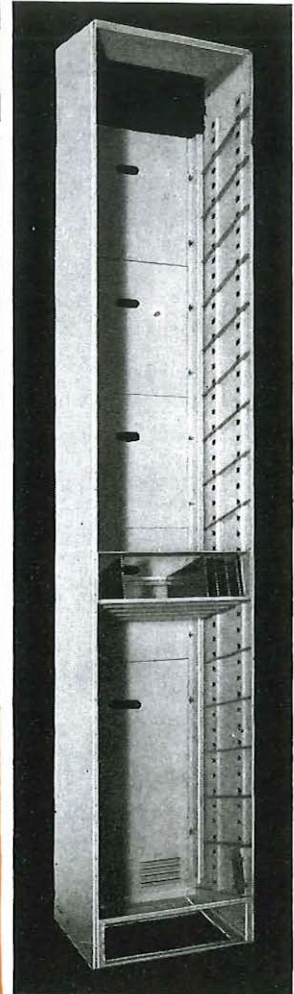
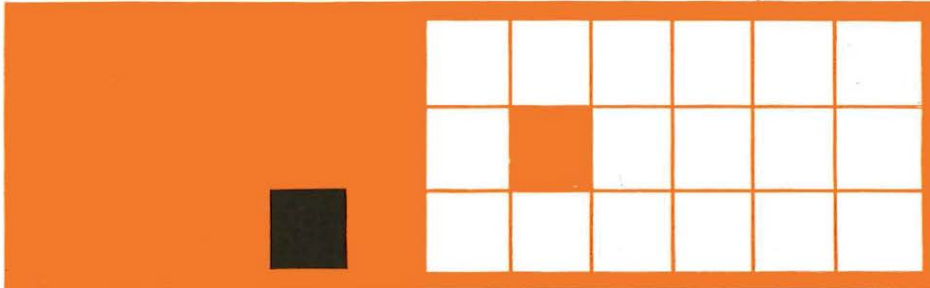
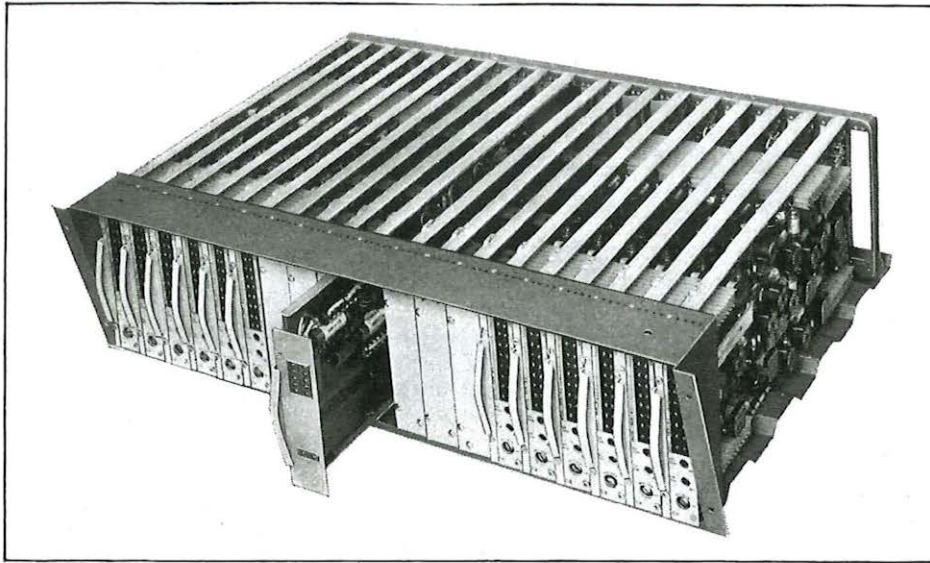

SHELF UNIT CONSTRUCTION/FLEXIBILITY IN EQUIPMENT LAYOUT

The shelf unit construction of the 62-type transmission multiplex equipment combines the compactness of modern equipment design with ease of installation and maintenance. The 450 mm deep racks are compatible with double-sided racks in existing installations which have the C.C.I.T.T. recommended depth. The design, which has been accepted as standard by the British G.P.O., gives maximum concentration of transistorized units in the rack space, yet with easy access from the rear to all wiring connexions. Soldered connexions in the station wiring are reduced to the minimum possible. Miniaturized components are mounted on well-screened plug-in printed circuit boards which by a simple extension device can be inspected and tested in their working positions. Reduction in equipment heat dissipation and improved ventilation avoids high equipment temperatures and gives more reliable performance. 62-type shelf units are supplied as factory wired and tested units which allow a high degree of flexibility in equipment layout and extensions. For further information write, 'phone or Telex: Standard Telephones and Cables Limited, Transmission Systems Group, Marketing Department, North Woolwich, London, E.16. Telephone ALBERT Dock 1401. Telex 21645.

world-wide telecommunications and electronics

STC

PITMAN BOOKS

ELECTRIC FILTER CIRCUITS

Professor Emrys Williams, Ph.D., B.Eng., M.I.E.E.,
M. Brit.I.R.E.

A new book by the author of "Thermionic Valve Circuits" specially designed for students with one year's experience of steady-state alternating current theory and who are familiar with elementary complex algebra. 25s net

AUTOMATIC VOLTAGE REGULATORS AND STABILIZERS

G. N. Patchett, Ph.D., B.Sc.(Hons.), M.I.E.E.

This book, completely revised in this new edition, deals with all types of automatic voltage regulators and stabilizers from those designed for use with a few watts in electronic equipment to those for use in the largest alternators of 100,000 megawatts and more. Second Edition £3 5s net

TELEGRAPHY

J. W. Freebody, B.Sc.(Eng.), A.C.G.I., D.I.C., M.I.E.E.

This book is the successor to T. E. Herbert's "Telegraphy", that indispensable work of reference used by engineers and telegraphists throughout the world since early in the century. 80s net

RADIO AND ELECTRONIC COMPONENTS VOL. III.

G. W. A. Dummer, M.B.E., M.I.E.

The second edition of Vol. III (Fixed Capacitors) in Mr. Dummer's well-known series for electronic engineers. A complete revision has been made in the light of recent developments and sixty new illustrations have been incorporated. Second Edition 45s net

from all booksellers

Pitman, Parker Street, London, W.C.2

VALUABLE FREE BOOK



Tells You How to Pass Your C. & G. Examination at First Attempt!

All Post Office personnel who are anxious to obtain early promotion should at once send for a copy of our handbook "ENGINEERING OPPORTUNITIES" which, among other intensely interesting matter, describes our unique methods of preparation for the CITY AND GUILDS EXAMINATIONS for the Telecommunication Technicians' Certificate and for individual subjects—Mathematics, Engineering Science, Engineering Drawing, Elementary Telecommunication Practice, Telecommunication Principles, Radio and Line Transmission, Telegraphy and Telephony, Line Plant Practice. It also contains details of our courses covering the G.C.E. subjects required for promotion to Assistant Engineer, Telecommunication Traffic Superintendent and other grades; and the City and Guilds examinations in Electrical Engineering Practice, the Grad.Brit.I.R.E. and A.M.S.E. Examinations, in addition to a wide range of non-examination courses in all branches of engineering—Radio and Electronics, Electrical, Mechanical, etc.

We also provide tuition for the Radio Amateurs' Examination and the P.M.G. Certificates for Radio Operators, with or without Morse training. Details are given in the handbook.

We definitely guarantee
"NO PASS — NO FEE"

If you intend to make the most of today's opportunities, you cannot afford to miss reading "ENGINEERING OPPORTUNITIES." It tells you everything you want to know to secure advancement, and describes many opportunities you may now be missing through lack of information. Send for your copy today—FREE and without obligation.

BRITISH INSTITUTE
OF ENGINEERING TECHNOLOGY
369 COLLEGE HOUSE,
29-31 WRIGHT'S LANE, LONDON, W.8

BIET

ROOTES TEMPAIR

AIR CONDITIONING

AIR at its best, temperature controlled and cleaned. Air with that natural outdoor quality that only REAL air conditioning gives you.

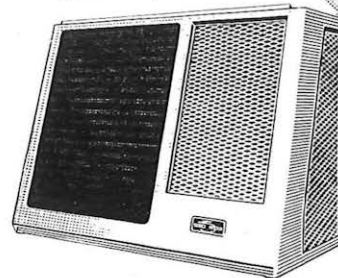

FOR CELLARS

Rootes Tempair Cellar Cooler maintains an even, natural temperature.

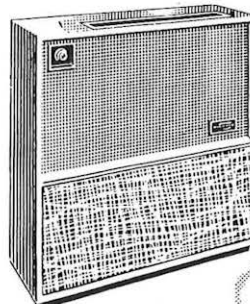

BOARDROOMS

Rootes Tempair Director free-standing unit delivers heated or refrigerated air, cleans and dehumidifies. Quiet running.

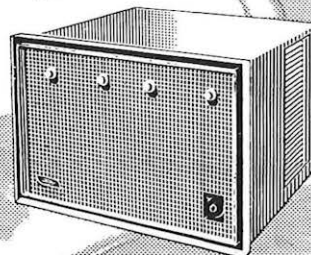

FOR BUSINESS

Rootes Tempair Pacific, window or wall models. Modern styling, complete and efficient air-conditioning. Freedom from noise and dust.

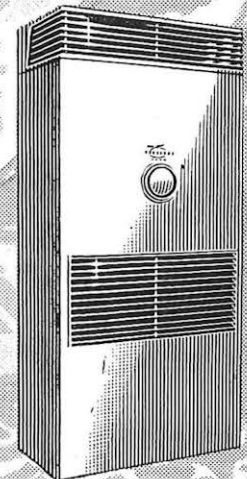

AND INDUSTRY

Rootes Tempair '5000' industrial air-conditioning for laboratories, computer rooms, small workshops, etc. High output, water or air cooled, economical in floor space.

Send this coupon today for details of range

To: TEMPAIR LIMITED · ROMNEY PLACE · MAIDSTONE
KENT · ENGLAND A Rootes Group Company.

Tick whichever applicable

Name _____

Address _____

CELLAR COOLER

DIRECTOR

PACIFIC

TEMPAIR '5000'

CUPO 3

Ernest Turner

Electrical Measuring Instruments

Ideally matching contemporary panel design, the Ernest Turner Model 703, illustrated here, is enhanced by the flush-fitting surround. A high degree of accuracy is adequately supported by the easy-to-read scale and clean dial layout. Full details of the range of rectangular electrical measuring instruments and flush mountings are contained in Leaflets 85/G and 85/AF, available on request.

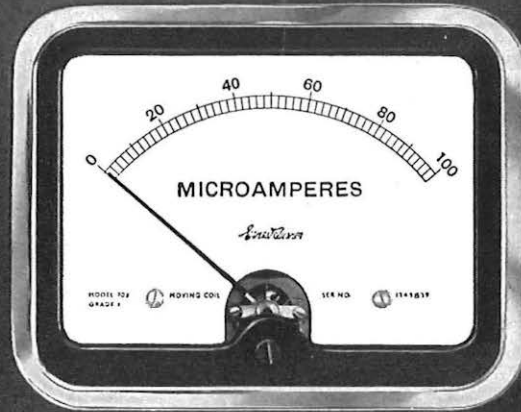

Ernest Turner Electrical Instruments Ltd

HIGH WYCOMBE · BUCKINGHAMSHIRE · ENGLAND

DENSO PROTECTION

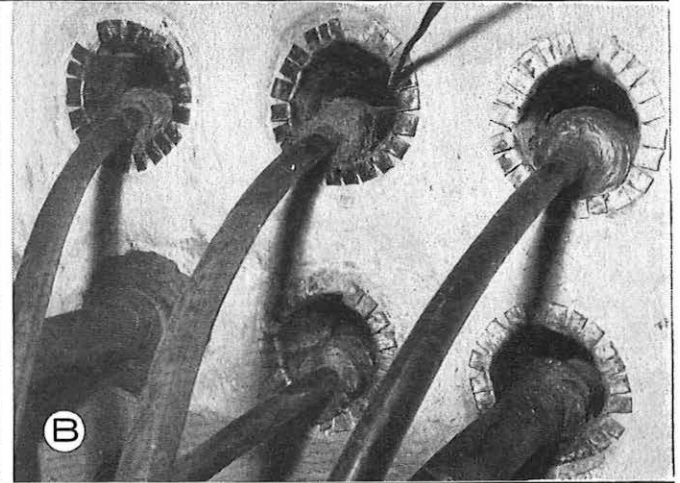
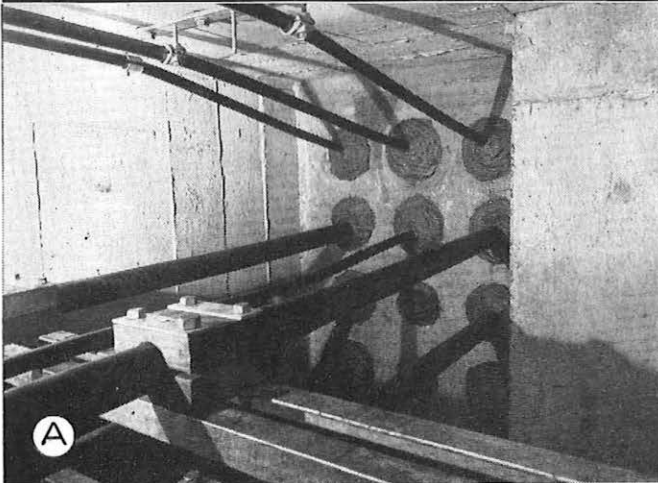

FOR CABLES AND PIPES

- A** Inside an inspection chamber — the cables are supported by steelwork and the ends of the duct sealed with Denso Mastic. Denso Mastic is the all-purpose cold applied sealing medium, and can be used for plugging, sealing and caulking duties below ground, above ground or underwater.
- B** Underground cables in ducts. Denso Tape is used to protect the cables where they pass over lead linings at the edge of the pipe in case the cable sinks onto the hard edges.

DENSO MASTIC and DENSO TAPE are used by the Central Electricity Generating Board, who also supplied the photographs.

WINN & COALES LTD

Denso House, Chapel Road, London, S.E.27.

Tel: GIPsy Hill 7511

Also at Manchester, Belfast and Dublin.

Agents throughout the Commonwealth.

A COMPLETELY SEMI-CONDUCTORED 7 Gc/s RADIO EQUIPMENT JOINS THE



MICROWAVE RANGE

- * Fully semi-conductored giving:—
 - low power consumption, less maintenance, battery operation.
- * Transmitters and Receivers are duplicated in a "twin-path" arrangement with I.F. switching at each terminal and repeater station.
- * A single rack, 7' 6" high, accommodates the duplicate Transmitters and Receivers, Modulators and Demodulators and is complete with the Automatic Switching, Service Channel and Supervisory Equipment.
- * A capacity of up to 3004 kc/s high quality telephony circuits.
- * Meets all C.C.I.R. recommendations for broadband radio equipment operating in the 7 Gc/s frequency bands.
- * Circuits may be dropped and inserted at intermediate repeater stations without demodulating the through circuits.



EVERYTHING FOR TELECOMMUNICATIONS

TRANSMISSION DIVISION

G.E.C. (TELECOMMUNICATIONS) LTD

Telephone Works · Coventry · England

Works at Coventry, Middlesbrough and Treforest

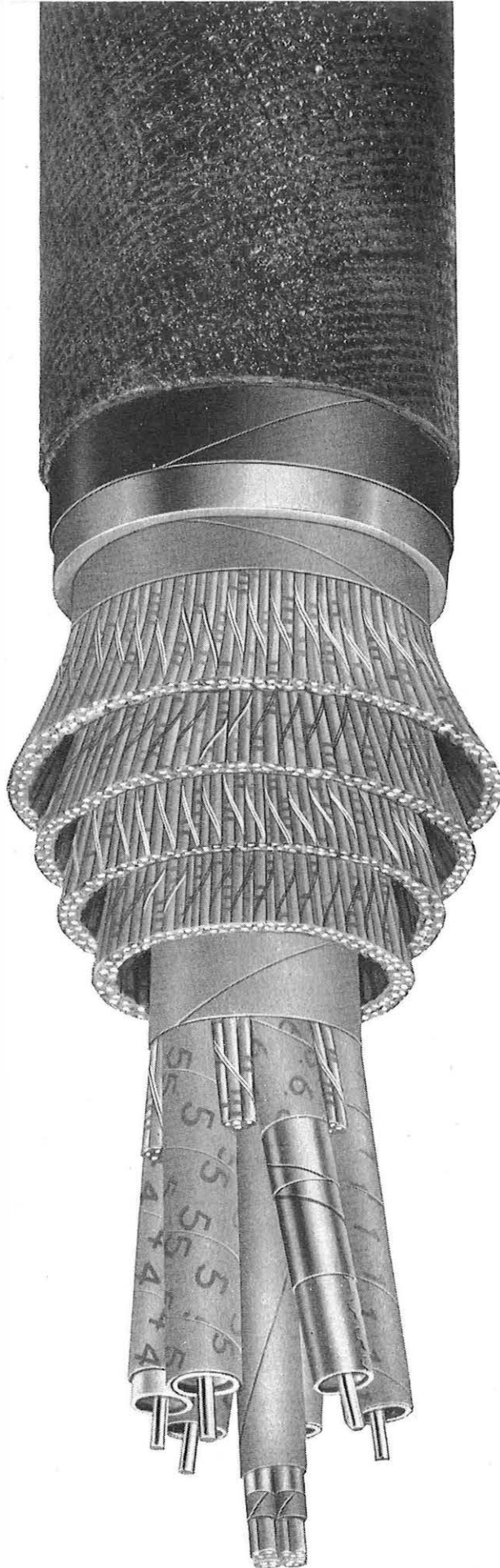

◀ **TYPE 375 COAXIAL CABLE**

For television circuits and multichannel telephony, BICC manufacture cables containing coaxial pairs meeting the C.C.I.T.T. recommendation G.334. These can be combined with symmetrical pairs for audio frequency or short-haul carrier circuits.

BICC



QUAD TRUNK CABLE

This cable, manufactured to a British Post Office specification, is produced in large quantities for audio frequency junction circuits. In common with other types of cable, they can be made to comply with any national or private specification.



UNIT TWIN CABLE

Large cables of unit construction are specially suited to the systematic arrangement of a dense telephone subscriber network. Units of 50 or 100 pairs are first assembled, then the required number of units are combined and sheathed to form the complete cable.

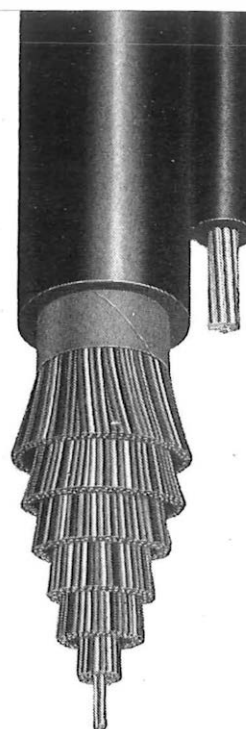

POLYTHENE INSULATED DISTRIBUTION CABLE

Because of their ease of installation, reliability and low cost, polythene insulated distribution cables are widely used, particularly in sizes up to 100 pairs. They may be installed underground or, as in the case of the type illustrated, used with an integral suspension strand wherever aerial installation is preferred.

TELEPHONE CABLES

are designed and manufactured to meet C.C.I.T.T. recommendations or any other specific requirements. They are the products of modern plant, specialist engineers and over sixty years of experience—backed by extensive research and development facilities. BICC undertake the manufacture and installation of cables for every type of telecommunication system anywhere in the World.

Technical information on BICC Telephone Cables is contained in our publications—freely available to Telephone Administrations.

Time and Tide

WAIT FOR





R NO MAN

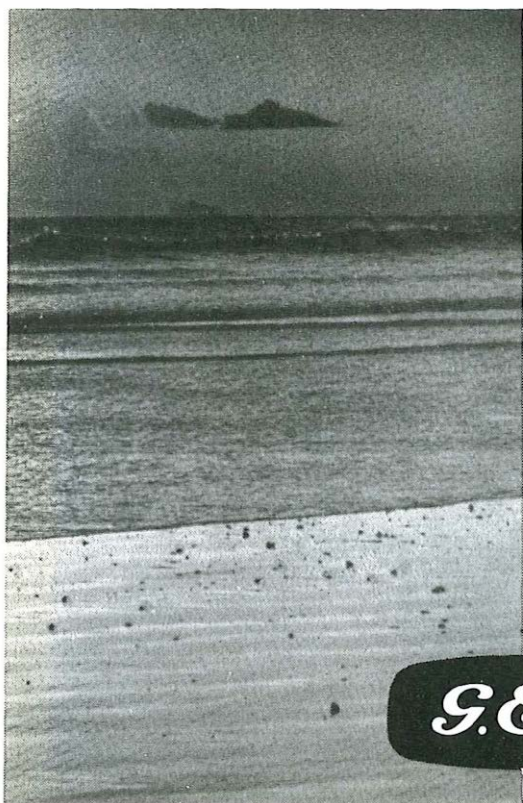

... and time is the essence of the fast tide of modern events. With time a premium, G.E.C. Telecommunications systems set the pace with advanced electronic exchanges that form the basis for modern networks. For fully integrated networks plan *now* with G.E.C.



EVERYTHING FOR TELECOMMUNICATIONS

Exchange Division :

G.E.C. (TELECOMMUNICATIONS) LTD · TELEPHONE WORKS · COVENTRY · ENGLAND

Works at Coventry, Middlesbrough and Treforest

G.E.C. 169



Trinistor

SILICON CONTROLLED RECTIFIERS

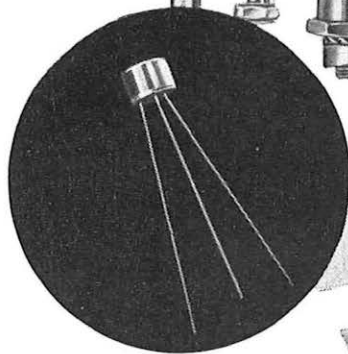

500 mA to

250 A

25-700 V

Full range of gate drive and controller
units readily available



Please write for full details to:—

Dept. PO.S4/64 Rectifier Division, Semiconductor Department,

WESTINGHOUSE BRAKE AND SIGNAL CO. LTD., 82 YORK WAY, KING'S CROSS, LONDON, N.1.

Tel: TERminus 6432. Telex No. 2-3225.

Marconi Self-Tuning H.F System
—the first in the world to be station
planned from input to output



breakthrough

MST 7½ kW transmitter H1100 series

An h.f linear amplifier transmitter for high-grade telecommunications.

Frequency range: H1100 and H1101, 4—27.5 Mc/s

H1102 and H1103, 2—27.5 Mc/s

Output power: 7—8 kW p.e.p., 5—6 kW c.w.

The H1100 series meets all CCIR Recommendations.

saves 85% floor space

Transmitters can be mounted side by side and back to back or against a wall; built-in cooling fan; no external air-ducts. These features lead to smaller, simpler, cheaper buildings or more services in existing buildings.

simplicity

R.F circuits have only three tuning controls and two range switches. Final valve can be replaced in 30 seconds. Miniature circuit breakers (used instead of fuses throughout) can be reset instantly. All sub-assemblies are easily tested because they are electrically complete units.

rugged reliability

Stainless steel shafts in ball-bearings in rigid machined castings; stainless steel spur gears meshing with silicon bronze; heavy r.f coil contacts with high contact pressure—some examples of design features giving long term endurance and operational reliability. Specified performance achieved with ample margins.

self-tuning

Types H1101 and H1103, used with MST drive equipment, give *one-man* control of an entire transmitting station and continuous automatic aerial loading.

MANUAL TUNING

Manually tuned versions, types H1100 and H1102, are available which, when fitted with built-in drive units, become entirely self-contained transmitters for four spot frequencies and all types of modulation. Manual tuning takes less than 60 seconds.

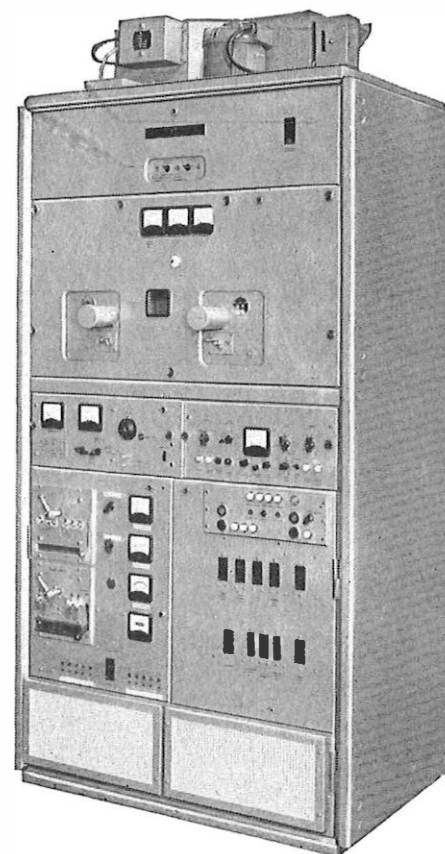

Marconi telecommunications systems

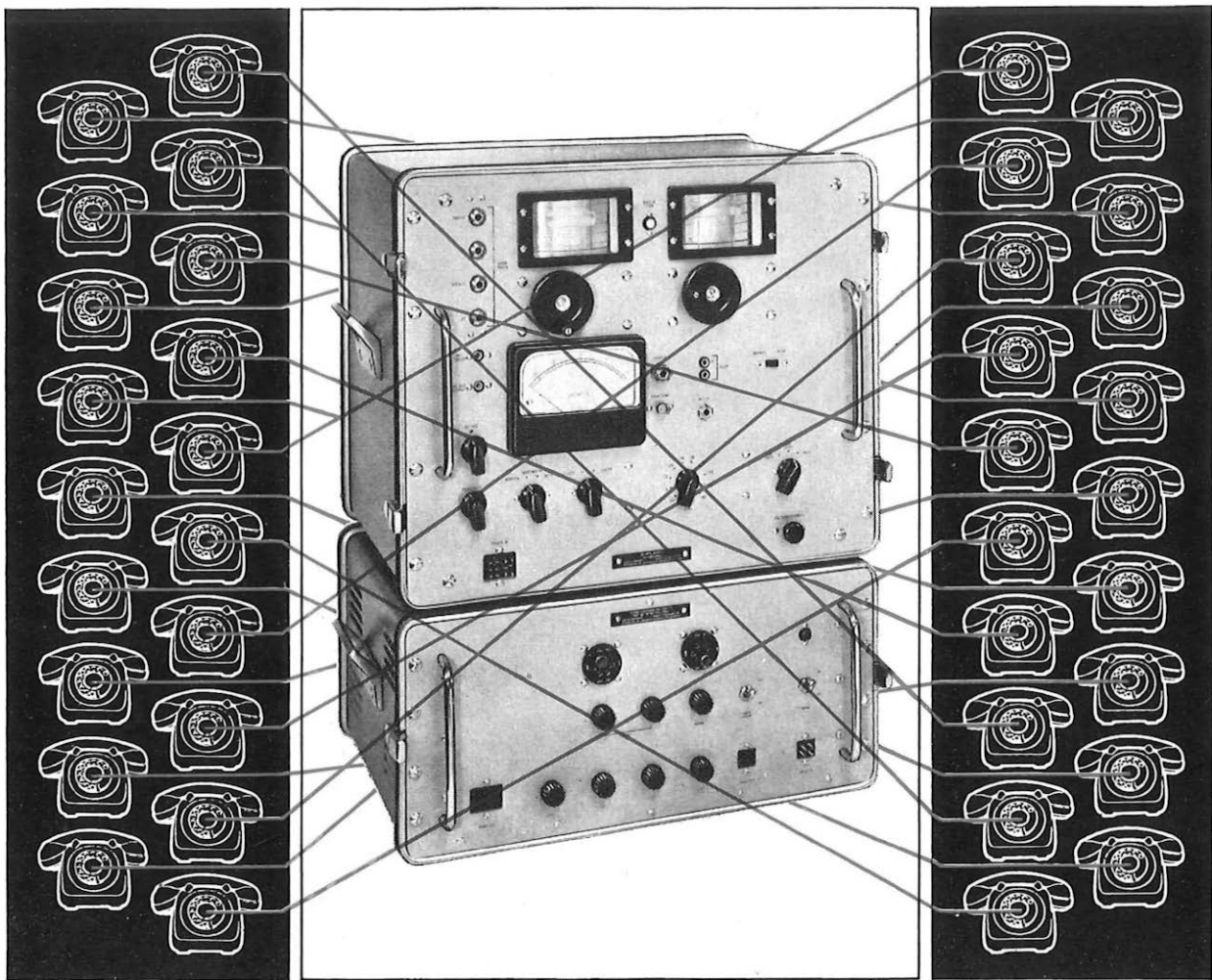

FOR LEVEL MEASUREMENTS IN TRAFFIC on coaxial telephone systems. The 74194-A Selective Level Measuring Equipment and the 74195-A Oscillator Equipment have the frequency accuracy and selectivity necessary for making measurements at intersupergroup and intermastergroup frequencies without interference with or from traffic. Low-level signals in voice channels can also be measured with no disturbance to or from adjacent channels. Their frequency range is 10 kc/s to 20 Mc/s with a frequency accuracy of \pm (400 c/s + 1 part in 10^5) after internal calibration. The frequency stability with $\pm 5\%$ mains voltage variation and $\pm 10^\circ\text{C}$ ambient temperature variation is \pm (200 c/s + 2 parts in 10^6), and the short-term stability is ± 10 c/s with constant mains voltage and ambient temperature.

74194-A S.L.M.E.

Measuring range +11 to -100 dbm
Bandwidths 4 kc/s and 200 c/s

74195-A Oscillator

Output levels 0 to -80 dbm
Harmonic margin 50 db

Each equipment includes a power unit for operation from 90-265V, 45-66 c/s, a.c. mains. Write, 'phone or Telex for further information to Standard Telephones and Cables Limited, Testing Apparatus Division, Corporation Road, Newport, Mon. Telephone Newport 72281. (S.T.D. ONE 3). Telex 49367. London Office: Telephone ALBERT Dock 1401 (Ext. 758).

world-wide telecommunications and electronics **STC**

COMBINED TAPE AND EDGE CARD READER

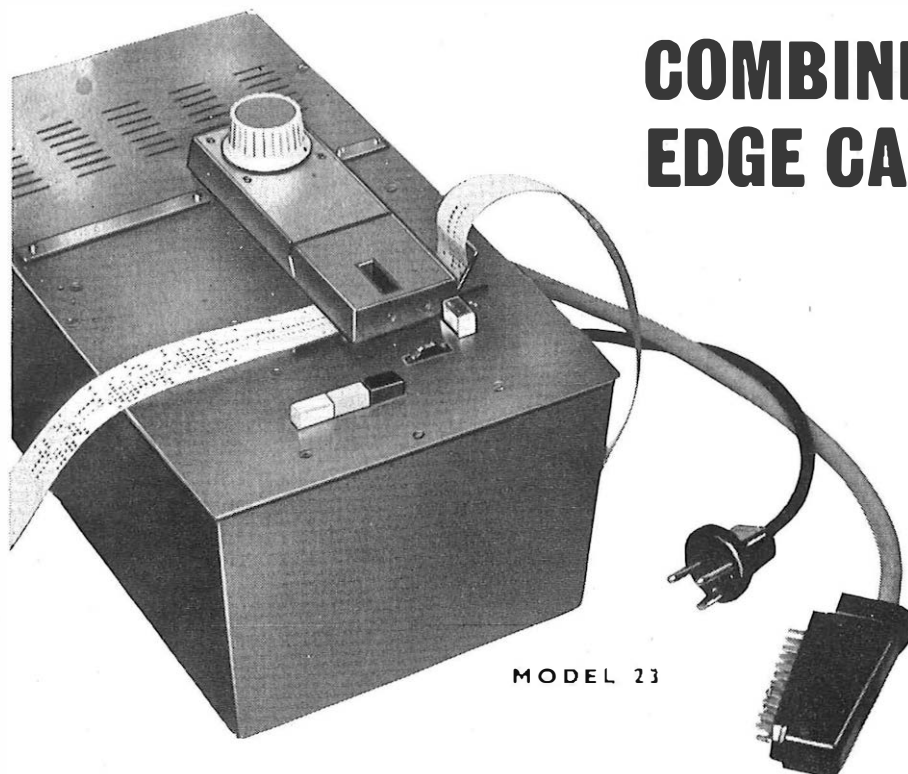

MODEL 23

- 5, 6, 7, 8 unit reading of tape and edge card
- Tight tape, tape out, tape latch alarms
- Unlimited manual forward and back-spacing of tape and card
- Free standing or flush mounting in a desk unit
- Signal contacts made for 95% of each reading cycle



GREAT NORTHERN TELEGRAPH WORKS

SYDHAVN'S PLADS 4, COPENHAGEN S.V. DENMARK

LONDON OFFICE: 5 ST. HELENS PLACE, LONDON, E.C.3

TEL: LONDON Wall 4567



"DRITAN" SOLID TANTALUM ELECTROLYTIC CAPACITORS

The range has been designed
in line with Spec. MIL. C-26655/2

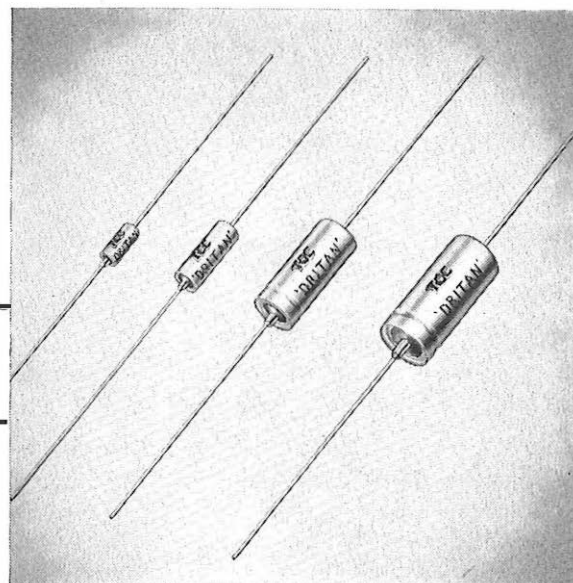

T.C.C. offer hermetically sealed solid electrolyte "Dritan" capacitors made to the most stringent performance characteristics.

Previous low leakage current limits have been cut in half and surge voltage limits increased, while the miniaturisation of these capacitors makes them ideal for use in such transistorised equipment as R.F. timing, integrating and differentiating circuits, and servo systems where large value of capacitance in small physical size is an essential requirement.

In "Dritan" Electrolytics there is no sacrifice of quality or reliability, and these capacitors are rated for operation over the temperature range of $-55^{\circ}\text{C}.$ to $+85^{\circ}\text{C}.$ With appropriate voltage derating, they may be operated at temperatures as high as $+125^{\circ}\text{C}.$ All T.C.C. "Dritan" Electrolytics are fitted with 'Melinex' insulating sleeving.

Temp. range: $-55^{\circ}\text{C}.$ to $+125^{\circ}\text{C}.$ (with voltage derating)
Voltage: Up to 50 V.D.C.
Cap. range: 0.0047 μF to 350 $\mu\text{F}.$
Cap. Tolerance: $\pm 20\%$ standard
 $\pm 10\%$ $\pm 5\%$ to special order

Polarized types only: Sintered slug or wire anode and solid electrolyte construction.

Maximum leakage current: $1 (\mu\text{A}) = 0.02 \text{ C} (\mu\text{F}) \cdot \text{V} (\text{volts})$ at room temp.
 $1 (\mu\text{A}) = 0.2 \text{ C} (\mu\text{F}) \cdot \text{V} (\text{volts})$ at $+85^{\circ}\text{C}.$

THE TELEGRAPH CONDENSER CO. LTD

NORTH ACTON · LONDON · W.3

Telephone: ACOrn 0061 Telex: 261383

G.E.C.

SHF MICROWAVE RADIO EQUIPMENT

The Bell Telephone Company of Canada has awarded a contract to Canadian General Electric Co. Ltd., for the supply of equipment for a new microwave system to link Quebec and Rivière-du-Loup with existing Bell Telephone microwave routes. The equipment, which will be manufactured by G.E.C. (Telecommunications) Ltd. in England, includes radio, multi-channel I.F. switching, and ancillary items for the system, and will be delivered in the fall of 1964.

The initial system will be 'twin-path', but will be capable of expansion to its maximum capacity (six working and two protection channels). It is designed to operate in the frequency band 5925-6425 megacycles. The radio equipment to be used is type SPO.5556, with a capacity of 1800 channels. It will meet all requirements of the CCIR 'circuit fictif', when carrying 1800 voice channels or a monochrome or colour TV picture on each radio channel.

The radio-protection switching equipment is type SPO.5325, capable of switching one protection channel for three working channels.

This equipment provides protection for the working channels by means of baseband and quick-acting contactless IF switches. Baseband switching will be required only when future radio channels terminate at Quebec and Rivière-du-Loup.

The overall equipment for the system will be similar to that ordered by the British Post Office for new microwave links between Southampton, London, Birmingham, Manchester and Carlisle.

For further information please write for Standard Specifications SPO 5556 and SPO 5325.

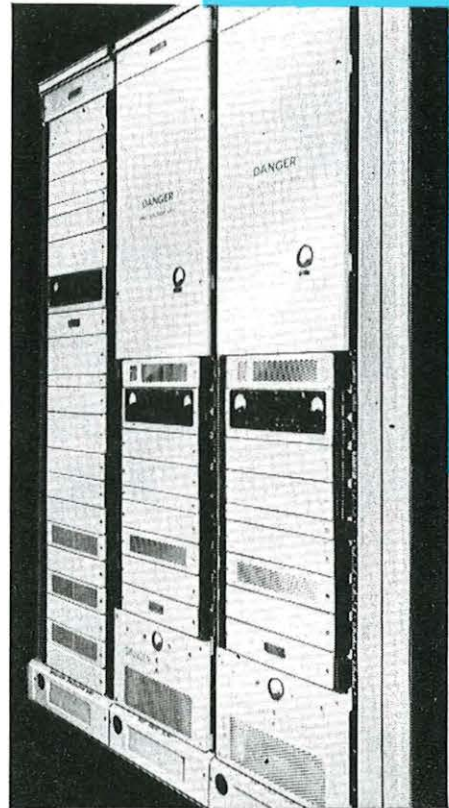

A typical S.H.F. twin-path terminal comprising one modulator/demodulator rack and two transmitter/receiver racks

EVERYTHING FOR TELECOMMUNICATIONS

FOR CANADA



SWITCHING TERMINAL
 REPEATER
 SCALE OF MILES
 0 10 20



TRANSMISSION DIVISION

G.E.C. (TELECOMMUNICATIONS) LIMITED
 TELEPHONE WORKS · COVENTRY · ENGLAND
 WORKS AT COVENTRY, MIDDLESBROUGH AND TREForest

INDEX TO ADVERTISERS

	PAGE		PAGE
Adeola Products, Ltd.	19	Pitman, Sir Isaac, & Sons, Ltd.	27
Automatic Telephone & Electric Co., Ltd. 10-11, 16-17,	23	Pye Telecommunications, Ltd.	12, 18
Avo, Ltd.	40	Rootes Tempair, Ltd.	27
British Institute of Engineering Technology	27	Sanders, W. H. (Electronics), Ltd.	21
British Insulated Callender's Cables, Ltd.	30-31	Standard Telephones & Cables, Ltd. 14, 24, 26, 36, 41, 42	42
Celeure, Ltd.	3	Submarine Cables, Ltd.	8
Ericsson Telephones, Ltd.	15, 20	Telegraph Condenser Co., Ltd.	37
G.E.C. (Telecommunications), Ltd. 4, 25, 29, 32-33, 38-39	39	Telephone Cables, Ltd.	6
Great Northern Telegraph Co., Ltd.	37	Telephone Manufacturing Co., Ltd.	7
Light Soldering Developments, Ltd.	2	Turner, Ernest. Electrical Instruments, Ltd.	28
Marconi Co., Ltd., The	9, 35	Westinghouse Brake & Signal Co., Ltd.	22, 34
Mullard, Ltd.	13	Whiteley Electrical Radio Co., Ltd.	19
National Salt Glazed Pipe Manufacturers' Association ...	5	Winn & Coales, Ltd.	28
Oxley Developments Co., Ltd.	2		

IMPROVED

Modern styling in light grey with legible black engraving.

Constructed to withstand adverse climatic conditions.

Ever ready case, including leads, prods and clips.

Improved internal assemblies.

Re-styled scale plate for easy rapid reading. 2 basic scales, each 2.5 inches in length.

New standards of accuracy, using an individually calibrated scale plate: d.c. ranges 2.25% of full scale deflection, a.c. ranges 2.75% of full scale deflection.

Available accessories include a 2500V d.c. multiplier and 5, 10 and 25A shunts for d.c. current measurement.

Dimensions (including case):—
7½ x 4 x 1½ ins. (197 x 102 x 41 mm.) approx.
Weight (including case):—
1½ lbs. (0.675 kg.) approx.

STANDARDS OF

ACCURACY AND RELIABILITY



Mk4

MULTIMINOR

The Mk.4 MULTIMINOR is an entirely new version of this famous Avo instrument and supersedes all previous models. It is styled on modern lines, with new high standards of accuracy, improved internal assemblies, and incorporating pan-climatic properties.

The instrument is supplied in an attractive black carrying case, which also houses a pair of leads with interchangeable prods and clips, and an instruction booklet. It is packed in an attractive display carton. Robust real leather cases are available, if required, in two sizes, one to take the instrument with leads, clips and prods, and the other to house these and also a high voltage multiplier and a d.c. shunt.

D.C. Current: 100μA f.s.d.—1A f.s.d. in 5 ranges.
A.C. Voltage: 10V f.s.d.—1,000 f.s.d. in 5 ranges.
D.C. Voltage: 2.5V f.s.d.—1,000 f.s.d. in 6 ranges.
D.C. Millivolt range: 0—100mV f.s.d.

RESISTANCE: 0-2M Ω in ranges, using 1.5V cell.
SENSITIVITY: 10,000 Ω/V on d.c. Voltage ranges.
1,000 Ω/V on a.c. Voltage ranges.

● For full details of this great new pocket size instrument, write for descriptive leaflet.

AVO LTD

AVOCET HOUSE, 92-96 VAUXHALL BRIDGE ROAD, LONDON, S.W.1.

Telephone: VICTORIA 3404 (12 lines)

M.

HM 17

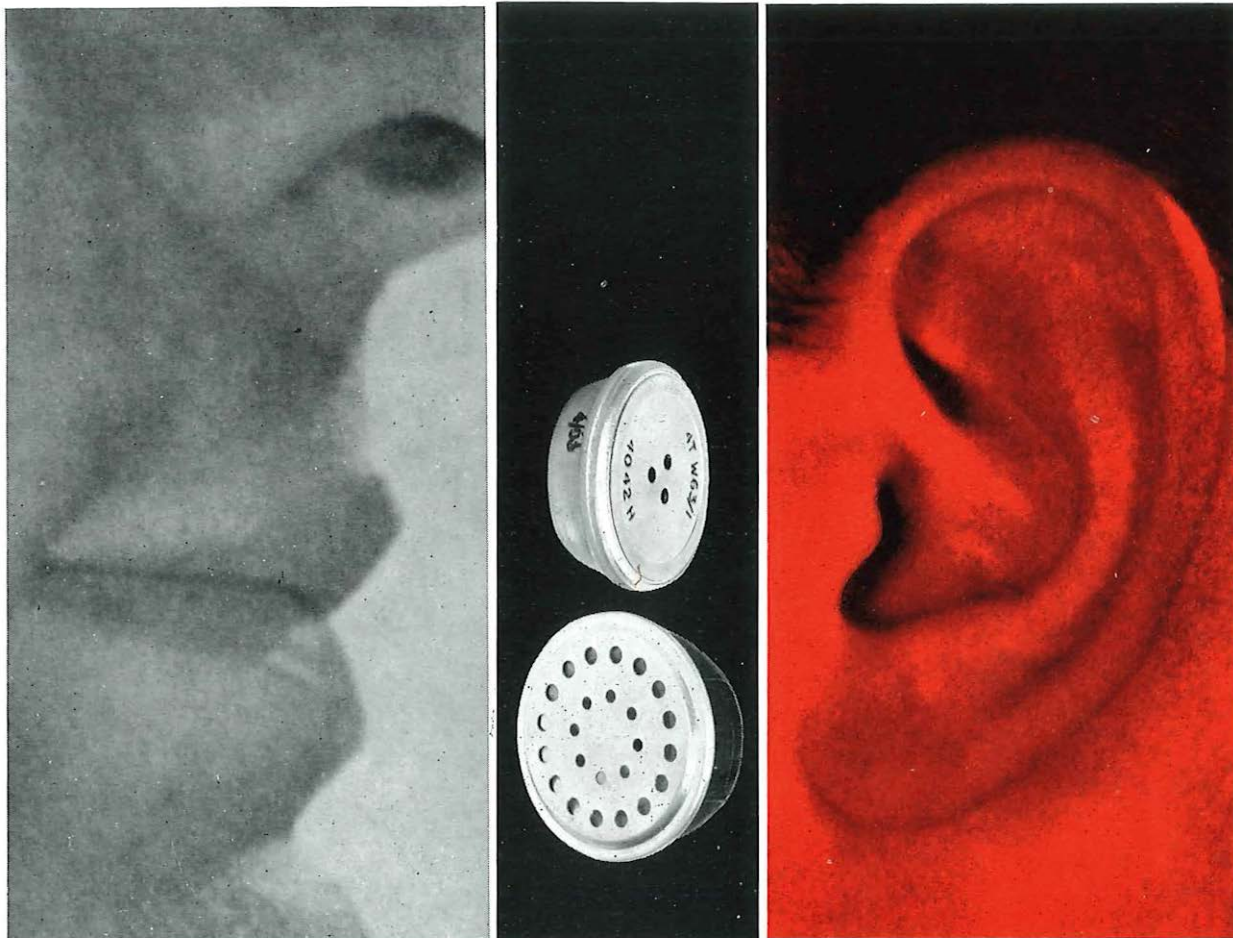

SOUND SENSITIVITY STC Transmitter and Receiver capsules bring greater definition to both ends of the line; extra sensitivity that makes a noticeable improvement to any sound communication system. STC Capsules are the means of up-grading audio reproduction and making the best of fine equipment.

Type 4041 Rocking Armature Receiver

A small lightweight receiver capsule suitable for telephone operators' headsets, telephone handsets and similar equipment.

Overall dimensions 1.54" x 0.62" (39 mm x 16 mm).

Weight 0.75 oz. (21 g). Available with impedance

of 300 ohms, and in multiples and sub-multiples.

Type 4042 Rocking Armature Receiver

The standard receiver capsule adopted by the British Post Office and other administrations throughout the world for use in telephone sets and handsets. Also used by services. 1.83" x 0.76" (47 mm x 19 mm). 1.25 oz. (35 g). Available in standard or tropical finish with impedance of 300 ohms, and in multiples and sub-multiples.

Type 4039 Carbon Transmitter

A small sensitive lightweight transmitter capsule for use in headsets, and handsets.

1.42" x 0.59" (36 mm x 15 mm). 0.5 oz. (15 g).

Type 4103 Rocking Armature Transmitter

For use in conjunction with an amplifier, in

handsets, hand-held microphones, pedestal mountings, loud speaking telephones, loud halers, etc. used extensively by armed forces, police, ambulance and fire services, etc. 1.83" x 0.77" (47 mm x 20 mm). 1.25 oz. (35 g). Available in standard or tropical finish.

Type 4125 Rocking Armature Transmitter

A small lightweight transmitter capsule for use in conjunction with an Amplifier, in aircrew headsets, and headsets used in radio and television studios. 1.54" x 0.78" (39 mm x 20 mm). 0.75 oz. (21 g).

Type 4050 Carbon Transmitter

The standard transmitter capsule adopted by the British Post Office and other administrations throughout the world for use in telephone sets and handsets. 2.29" x 0.95" (58 mm x 24 mm). 1.2 oz. (32 g).

Write, 'phone or Telex: Telephone Switching Division, Standard Telephones and Cables Limited, Oakleigh Road, New Southgate, London, N.11. Telephone ENTerprise 1234. Telex 21612.

STC

world-wide telecommunications and electronics

STEPMASTER P.A.B.X.'s 20, 50 OR 100 LINE UNITS



GOOD COMMUNICATION facilities in an industrial organization are now recognized as a necessity at all administrative levels. Time saved by obtaining immediate contact with other members of the staff is of inestimable value to all, from the Managing Director to the junior clerk, and the capital cost of providing a properly planned system is small compared with the incalculable losses sustained by having inefficient communications. For many years STC has designed, manufactured and installed Private Automatic Branch Exchanges of various types. As a result of this experience, a large fund of expert knowledge is available, and any technical advice that may be required will be furnished gladly on request.

New light-weight high performance handset B.P.O. type "long life" components Transistorized ringing and tone circuits All "plug-in" type equipment Quick and easy expansion to full capacity Simple installation and maintenance Full tropical finish.

Details from Standard Telephones and Cables Limited, Telephone Switching Division, Oakleigh Road, New Southgate, N.11. Telephone ENTerprise 1234. Telex 21612.

world-wide telecommunications and electronics **STC**