

# THE POST OFFICE ELECTRICAL ENGINEERS' JOURNAL

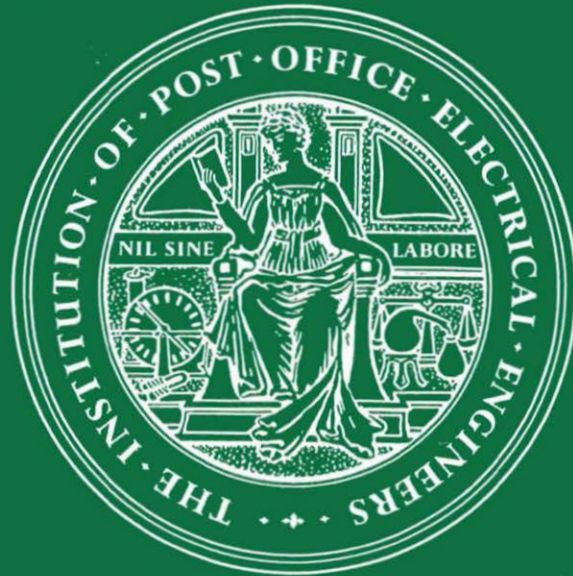

## C O N T E N T S

|   | Page  |
|---|---|
| *COMMUNICATIONS IN THE PUBLIC SERVICE OF THE UNITED KINGDOM—Sir Albert Mumford, K.B.E., B.Sc.(Eng.), F.Q.M.C., President I.E.E. ....  | 223   |
| A NEW WATCH RECEIVER—RECEIVER, WATCH, No. 8T—F. E. Troke, A.M.I.E.E. ....   | 230   |
| THE MANUFACTURE OF EARTHENWARE DUCTS—D. W. Stenson, B.Sc.(Eng.) ....  | 231   |
| AUTOMATIC SWITCHING OF INLAND CARRIER-LINK SECTIONS OF TRANSATLANTIC TELEPHONE CABLE SYSTEMS—R. S. G. Wooding.....  | 237   |
| DESIGN AND TECHNOLOGY OF SILICON PLANAR TRANSISTORS—J. C. Henderson, B.Sc., A.Inst.P., and Sylvia J. Wilson, B.Sc.....  | 239   |
| INLAND RADIO PLANNING AND PROVISION BRANCH EXHIBITIONS AT 2-12 GRESHAM STREET, LONDON, E.C.2.....   | 244   |
| STANDARDIZATION AND CONTROL OF COLOUR FOR THE 700-TYPE TELEPHONE—Joan L. Craft.....   | 247   |
| THE EXTRAORDINARY ADMINISTRATIVE RADIO CONFERENCE, GENEVA, 7 OCTOBER-8 NOVEMBER, 1963.....  | 251   |
| RAISING AND SETTING MANHOLE AND JOINT-BOX FRAMES AND COVERS USING POLYESTER RESIN—A. F. L. Hearn.....   | 252   |
| AN EXPERIMENTAL 3-DIGIT ELECTRONIC DIRECTOR USING MAGNETIC-CORE CIRCUITS W. A. E. Loughhead, B.Sc.(Tech.), A.M.I.E.E., and G. A. Matthews, B.Sc. ....   | 255   |
| AN ELECTRONIC TELEGRAPH BUFFER STORE USING A MAGNETIC DRUM—J. M. Robins, M.A.(Cantab.), and A. C. Croisdale, M.B.E., B.Sc.(Eng.), A.M.I.E.E.....  | 262   |
| OUTLINE OF TRANSISTOR CHARACTERISTICS AND APPLICATIONS, Part 3—Application of Non-Linear Characteristics—J. A. T. French, B.Sc.(Eng.), A.M.I.E.E., D. J. Harding, B.Sc.(Eng.), A.M.I.E.E., and J. R. Jarvis, B.Sc.(Eng.), A.M.I.E.E. .... | 268   |
| TESTING FACILITIES AND METHODS FOR THE 405-LINE TELEVISION NETWORKS R. Gardiner, Associate I.E.E. ....  | 275   |
| THE TESTING OF PLASTICS—P. E. Taylor, Ph.D., B.Sc., A.R.I.C.....  | 280   |
| NOTES AND COMMENTS.....   | 283   |
| INSTITUTION OF POST OFFICE ELECTRICAL ENGINEERS.....  | 284   |
| REGIONAL NOTES.....   | 286   |
| ASSOCIATE SECTION NOTES.....  | 288   |
| STAFF CHANGES.....  | 291   |
| INDEX TO VOLUME 56.....   | 294   |
| BOOK REVIEWS.....   | 229, 236, 243, 250, 261, 267, 274, 279, 285 |

\*Reproduced by permission of The Institution of Electrical Engineers.

Price 2s. 6d. (Post Paid 3s. 6d.)

Published in April, July, October and January by *The Post Office Electrical Engineers' Journal*,  
G.P.O., 2-12 Gresham Street, London, E.C.2.

# THE POST OFFICE ELECTRICAL ENGINEERS' JOURNAL

Vol. 56 Part 4

JANUARY 1964

## Communications in the Public Service of the United Kingdom\*

Sir ALBERT MUMFORD, K.B.E., B.Sc.(Eng.), F.Q.M.C., President I.E.E.†

U.D.C. 621.39:654.1 (41-4)

This paper was delivered by Sir Albert Mumford, K.B.E., on the occasion of his Inaugural Address as President of The Institution of Electrical Engineers on Thursday, 10 October 1963. Sir Albert, who is Engineer-in-Chief of the British Post Office, is also President of The Institution of Post Office Electrical Engineers. The Board of Editors are, therefore, grateful to The Institution of Electrical Engineers for permission to reprint this paper, in which Sir Albert outlines the increasing trend towards full automation of the public telephone service, and describes developments in the transmission field that will provide more circuits at lower costs. He also discusses the demands of television and how these demands are integrated with the other public services in the United Kingdom, and, finally, considers the problem of world-wide telecommunications including the special role of satellites.

NO newly elected President of this Institution can be unmindful of the honour conferred on him by his fellow members. The honour is one which gives me the greater pleasure, since, following the founding of this Institution in 1871 as the Society of Telegraph Engineers, eight of my predecessors have also held the office of Engineer-in-Chief of the General Post Office. I am therefore particularly appreciative of the honour you have conferred in electing me President of this Institution with its membership of more than 50,000.

The new Divisional structure of the Institution, which has now completed its first full year of operation, has demonstrated its worth, and with the comprehensive cover in breadth and penetration in depth provided by the work of the Professional Groups within each Division we are clearly well poised to follow the increasing pace of technical developments. The Electronics and Power Divisions have taken advantage of the spirit and traditions associated with the original Sections. Their success—and I say this with all due respect—is not unexpected but is nevertheless something of which to be proud and upon which they are to be congratulated. However, what has been so pleasing has been the welcome given to the formation of the Science and General Division by the general body of members, and the upsurge of papers on subjects previously attracting but little attention. Here was a field needing more scope than was to be found under our previous organization, and I am confident that

the latest developments of science will now be the more quickly related to the work of the professional electrical and electronic engineer. I congratulate this Division, and in particular, its Chairman for last session—Dr. Denis Taylor—on the way in which they have seized the opportunities offered.

“To an increasing extent the lives of our people are bound up with engineering development, and the economics of our welfare are dependent to a large extent upon the rate of this development. The full implications of social science can best be handled from the engineering side by the combined efforts of all the engineering professions.”

These words were said by Sir George Lee in his Inaugural Address in 1937 and, if possible, they are truer today than then. Last year was particularly significant, since the inauguration of the Engineering Institutions Joint Council in October 1962 offers opportunities of a fuller and more effective collaboration between Institutions where so much remains to be done and where speed is so vital. In this Council, the Institution has joined in association with 12 other professional engineering societies to promote the advancement of engineering and the dissemination of knowledge in that field. In some fields, collaboration has developed and will continue in a more personal way. I have in mind, of course, collaboration between the British Institution of Radio Engineers and ourselves, expressed, for instance, in our joint activities in the educational, computer and medical-electronics fields and in the co-sponsorship with them and with the interested American societies, of the highly successful International Telemetry Conference which has just been held in London. I am pleased to say that this collaboration with our sister Institution, whose field of activity we share, is to be seen not only in London but in our local Centres also.

Tonight, as you might well expect, I propose to take as the main theme of my Address “Communications in the public service of the United Kingdom.” The change-over from manual to automatic telephones is almost a matter of history—almost but not quite. The introduction of S.T.D., in which subscribers may dial their own trunk calls, is well known, and a facility already available to many. The extension of such a facility to the

\*Reproduced by permission of The Institution of Electrical Engineers.

†Engineer-in-Chief.

making of international calls, other than in the telex field, is new. Much economy is to be realized by such full automation of a public service, but the extent depends on subscribers having ready access to an adequate supply of good-quality and highly reliable trunk and overseas circuits. I decided, therefore, to describe, having first outlined the increasing trend towards full automation of the public service, some of the developments which have been, and are, taking place in the transmission field, giving more circuits at lower cost—a somewhat natural choice for an engineer who has spent much of his career on such developments. He will take the liberty of discussing the demands of television, and how they are integrated with the other services for the public in Britain, before considering world-wide communication.

#### TREND TOWARDS AUTOMATION

Today, some 9 million telephones are connected to the public network, and of these more than 85 per cent are served from automatic exchanges. In 1925, when Col. T. F. Purves read before this Institution a paper on "The Post Office and Automatic Telephones," there were only some 50,000 automatic out of a total of 1¼ million telephones, just over 4 per cent. Although automation of the network was expected to be completed by 1945, this was not to be. Having peaked at some 1.6 million in 1956, the number of manual telephones today is, curiously enough, still only slightly less than it was in 1925. Present plans, however, provide for complete conversion by 1970. The postwar growth of the telephone system is shown in Fig. 1.

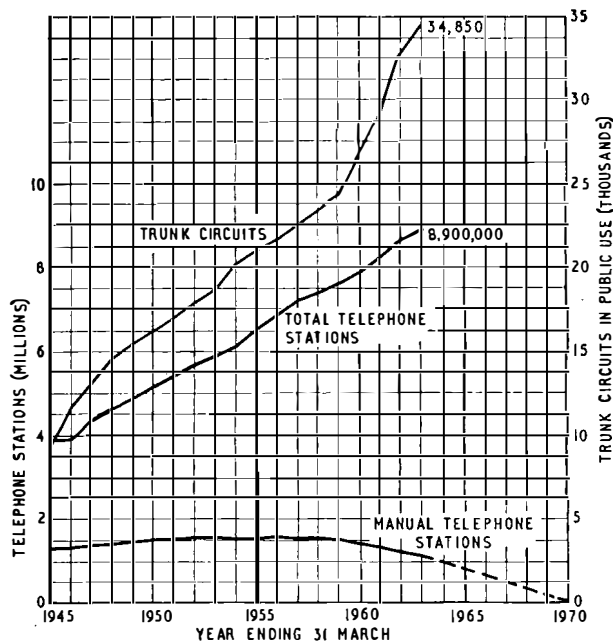

FIG. 1—GROWTH OF TELEPHONE STATIONS AND TRUNK CIRCUITS (OVER 25 MILES IN LENGTH) BETWEEN 1945 AND 1963

Subscriber trunk dialling (S.T.D.), initiated at Bristol in December 1958, gives telephone subscribers the facility of establishing their own trunk calls without the intervention of an operator. Such a facility cannot, of course, be given immediately to all subscribers, but rapid progress is being made in extending the facility. Thus, by March 1964 nearly 90 per cent of subscribers will be connected to automatic exchanges, and some 40 per cent have

S.T.D. Both the process of conversion from manual to automatic, and the extension of S.T.D. to all subscribers, are planned for completion by 1970.

The next logical step is for subscribers to dial their own international calls, and this was, in fact, started in March 1963, when international subscriber dialling (I.S.D.) from London to Paris was introduced. Immediately, some 360,000 S.T.D. subscribers in London could dial calls directly to many Paris numbers. All S.T.D. subscribers in London should be able, by the spring of 1964, to dial their own calls to all large cities and towns in France, and to almost all exchanges in Belgium, the Netherlands, Switzerland and Western Germany. Then, by early 1965, when further extensions are planned to Denmark, Norway and Sweden, subscribers in five other large cities in Britain—Birmingham, Liverpool, Manchester, Edinburgh and Glasgow—will have this facility of dialling all such overseas calls; more and more towns will be brought into this I.S.D. network until eventually it will be possible for most of the international calls to be dialled by subscribers themselves. Such developments involve much detailed study of the various factors involved in an ambitious project, not all of which are technical; much of this work is done under the auspices of the C.C.I.T.T.\*

The development of the I.S.D. facility follows the same pattern as that of S.T.D.; it first becomes available to operators and then in due course to the subscribers. Operators are already dialling direct to subscribers in nine European countries and to the United States; and with the completion of the COMPAC cable by the end of 1963, they will be able to do so to Australia, during 1964 to Canada and during 1966 to New Zealand. While world-wide subscriber dialling is an obvious ultimate target, difficulties arise because of the non-uniformity of dials (e.g. identity of 1 and I, and nought and O) and the high cost of a misdialled call.

#### TELEX SERVICE

Telex service is a rapid and reliable message inter-communication service which combines the speed of the telephone connexion with the authority of the printed word. Messages can be on the desks of the recipients within a minute or so of the decision to send them at any time through the 24 hours. For international communication it reduces the language difficulties, and since messages may be transmitted to non-attended stations, it overcomes the problem of the wide difference in local time between distant countries. The automatic answer-back facility of the recipient's teleprinter gives positive confirmation that the required subscriber has been reached. Such a service was opened in 1932 with calls carried over the telephone network, and in 1947 a separate, manually switched telegraph network was introduced. Conversion to automatic switching commenced in 1958 and was completed with the opening of the London Fleet Exchange in December 1960. Subscriber dialling is now available throughout the United Kingdom and to most European countries. Side by side with its growth in Britain, the telex service has expanded to most other countries throughout the world, either over radio links fitted with error-correction equipment or over the modern long-distance repeatered submarine cables; most of the extra-European calls are dialled by the London telex operators.

\*C.C.I.T.T.—International Telegraph and Telephone Consultative Committee.

There are at present over 10,000 telex subscribers in Britain, and the number is expanding rapidly. Calls to subscribers in Britain and to Europe are charged on a time-and-distance basis recorded as units on the subscriber's meter. Calls outside Europe are separately recorded, and automatic ticketing equipment for the purpose is now being developed. This will enable direct subscriber dialling to be extended all over the world, commencing in 1964 with North America. Fig. 2 shows

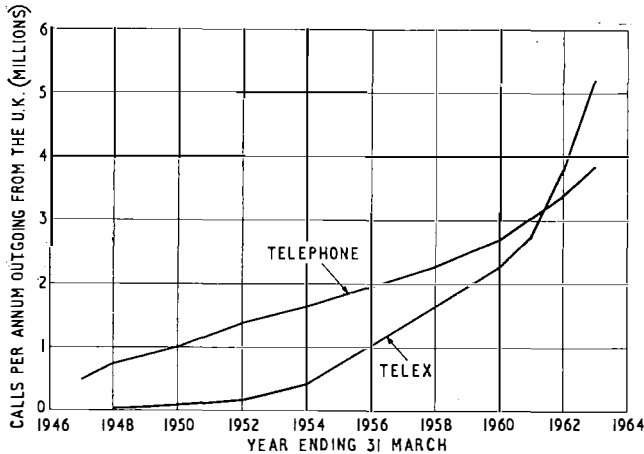

FIG. 2—GROWTH OF TELEPHONE AND TELEX TRAFFIC TO EUROPE

the growth of telex traffic to Europe and compares it with that of the telephone service.

A growing need of commercial and industrial organizations is the transmission of digital-data information over the telex and telephone networks. Such facilities are required for the transmission of digital data, often from many outstations to a central computer for processing or between two computers. The telex network is directly capable of transmitting digital signals at 50 bits per second, and facilities are now being provided for automatic error checking of such transmissions. For higher transmission rates, the telephone network can be used. All telephone connexions are capable of carrying data signals at 600 bits per second and a high percentage at 1,200 bits per second. Modulators for these speeds have been designed which may be switched to the normal telephone line in place of the telephone handset. Where a large quantity of data is to be transmitted between two points, a private telephone circuit is more economical; and specially equalized circuits capable of transmission rates of up to 2,400 bits per second may be rented.

#### DEVELOPMENTS IN THE TRUNK NETWORK

The economy resulting from any subscriber-dialled service will be lost should the subscriber decide, for instance at times of peak demand, that he is having to make an undue number of attempts to obtain his own calls and, as a consequence, transfers his demand to the small remaining operator-controlled service. An adequate supply of trunk circuits is therefore a necessity with the rapid growth of S.T.D. Currently, trunk calls are rising by some 15 per cent per annum (compared with 5½ per cent for local calls), and the provision of circuits must reflect this increase reasonably closely if an adequate return is to be obtained from the very considerable capital expenditure involved. The growth of the

trunk network since 1945 is shown in Fig. 1.

Provision of trunk telephone circuits in the last decade or so has been mainly by further exploitation of carrier techniques on coaxial cables. Currently, as many as 2,700 separate telephone conversations can be carried by one pair of coaxial tubes, and 960 per pair of tubes is normal on main routes. Although the cost per circuit on systems with such large numbers of circuits is relatively small, the systems themselves are expensive, and their use is restricted to routes such as those between cities requiring large numbers of circuits. Using the normal ¾ in. diameter coaxial tubes, the standard amplifier spacing is six miles, and with this spacing a band 60 kc/s–4 Mc/s wide is available for the transmission of either 405-line television or multi-channel telephony. Systems giving a 12 Mc/s bandwidth have also been developed and introduced into service, providing three 900-telephone-channel mastergroups, two of which can be used for the transmission of colour television if necessary. The increased loss in the cable at the higher frequencies used has meant the provision of repeater stations every three miles. The difficulty in finding suitable locations for repeater stations, even for the 6-mile spacing, is not only appreciable but increasing. The delay in the acquisition of sites, first in finding an owner who is willing to sell and then in completing legal processes and obtaining the necessary consents for the buildings, is serious; it results in much retardation of many urgent schemes. Within the acceptable distance limits, it may not even be practicable to find a site on the track of the cable, and the costs of having to go off the track down a spur road, for example, can be high. Clearly the difficulties rise more than proportionately with a reduction in spacing to 3 miles. Housing the amplifiers in manholes or jointing chambers has frequently been considered, but with valve amplifiers, needing high-voltage power-feeding and very special safety requirements, such a solution has never been really practicable. However, highly reliable transistorized amplifiers have now been developed, and their small size and low power requirements permit them to be housed in jointing chambers or manholes in the footway. This gives a much higher degree of freedom for reducing the spacing between repeaters; and spacings as close as 1 mile are feasible. A choice can therefore be made between using the normal ¾ in. diameter coaxial tubes of low attenuation with a wide spacing between repeaters and using the smaller-diameter tubes of higher attenuation requiring a close repeater spacing. Economies are frequently possible with small coaxial tubes, and already the C.C.I.T.T. has recommended standards for general adoption. Coaxial pairs of ½ in. diameter are now in use with an upper-frequency working limit of just over 1 Mc/s; the attenuation at 1 Mc/s is  $8.5 \pm 0.2$  db per mile and the amplifier spacing about 3½ miles. The development of the small coaxial cable, and its association with underground amplifiers and low-voltage power feeding, have produced a system providing up to 300 circuits for the less heavily loaded routes between smaller towns, at lower cost than was possible with the previous use of audio-type cables with a separate pair of wires for each conversation. Already systems using the small coaxial cable with its associated underground amplifiers are being installed giving a 4 Mc/s bandwidth, capable of carrying up to 960 telephone circuits per pair of tubes at lower cost than those using the ¾ in. coaxial cable. These developments may well mean that the ¾ in. cable will be little

used for new work except where 12 Mc/s working is visualized at a relatively early date.

Microwave radio-link systems are now being extensively developed for expansion of the trunk network, and are capable of meeting both telephone and television requirements. Such systems, using point-to-point radio transmission at frequencies of about 2,000, 4,000 or 6,000 Mc/s, can transmit, for instance, either a single high-quality 625-line colour-television signal or as many as 960 telephone conversations; or even, when required on certain main routes, 1,800 conversations. Failure of a microwave channel is covered by the provision of a spare channel automatically switched into service at times of need. Reductions in cost are being achieved by using only one spare channel to cover the possibility of failure in a number of working channels and by the development of new forms of aerial capable of being shared by many separate systems at common repeater points. The aeriels must be sited high enough to receive and transmit well above all surrounding buildings or topographical features. This often involves the building of high supporting structures, one example of which is the Post Office Tower in London (Fig. 3), now in an

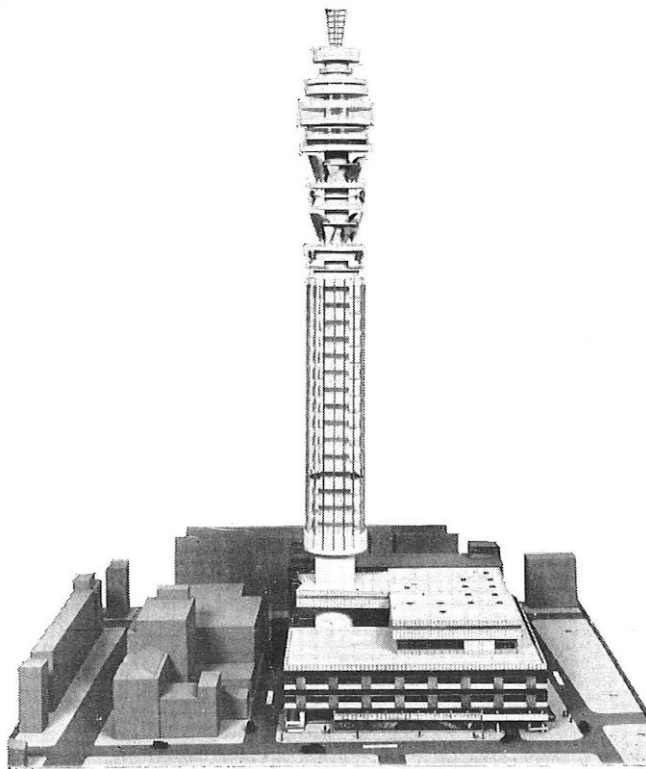

FIG. 3—MODEL OF POST OFFICE TOWER IN LONDON

advanced stage of construction; on this 600 ft tower the aeriels are some 350-470 ft above the ground. It has been designed to house equipment and aerial systems covering London's long-distance telephone-circuit and television-channel requirements for many years to come; and it will, if necessary, eventually handle up to 150,000 simultaneous telephone conversations, as well as 40 or more channels for television. Another somewhat similar tower is being erected in Birmingham. At a number of other cities, the terminal radio station have been placed on high ground outside the cities and con-

nected to the city centre by coaxial cable. However, in London and Birmingham, where the number of circuits required is so much greater, such arrangements were not economic.

Substantial reductions in the cost of providing trunk circuits have been effected over the past 50 years, and the extent of these reductions is indicated in Fig. 4 as

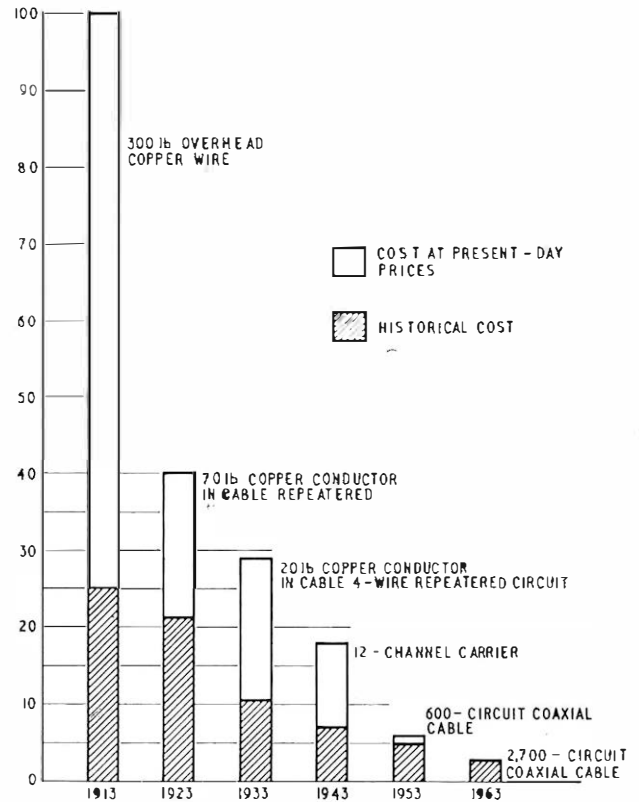

FIG. 4—RELATIVE CAPITAL COST OF PROVIDING A 100-MILE TRUNK CIRCUIT DURING THE PERIOD 1913-63

applied to the provision of a fully equipped 100-mile trunk route. The Figure also shows the present-day cost that would apply for the current provision if the original form of construction were used.

Up to the present, high-frequency carrier working has, generally speaking, not been more economic than audio working at distances below 30 miles. In a 30-mile frequency-division multiplex (f.d.m.) carrier system, 80 per cent of the cost is in the terminal equipment used to derive the individual channels from the wideband circuit. The most important factor is thus to reduce the cost of the terminal equipment. Technical development and increased production have enabled this to be done continuously over the past years, so that the shortest economic distance for high-frequency working has been progressively reduced. Nevertheless, there remain large numbers of circuits in the distance range 10-20 miles which at the moment can most economically be provided by means of audio cables. Maybe the time has come when cheaper terminal equipments can best be developed by taking advantage of the logical role of the transistor as a switch to exploit the available bandwidth by time-division multiplex (t.d.m.). This could well lead to h.f. working becoming economic over the shorter distances, offering an attractive means at relatively low cost of increasing the number of circuits available from existing

cables. So far as the longer distances are concerned, the use of t.d.m. can be cheaper than f.d.m. only if its greater bandwidth requirements (at least ten times greater) can be offset by lower terminal costs and such lesser use of regenerators (the equivalent of the amplifiers in f.d.m.) as can result from the greater tolerance of t.d.m. to noise. These possibilities are being studied.

#### TELEVISION FACILITIES

The wide use of coaxial-cable and microwave-radio systems means that wideband circuits are available throughout much of Britain for multi-channel telephony, television, or other purposes. The integration of all such services into a common network results in economical provision and gives much flexibility of use. Television, in particular, makes large demands on wideband facilities, and at the present time about one third of all microwave and coaxial-cable channels are used for television. Thus there are some 60 main-line vision channels—totalling some 6,000 channel miles—carrying the program material of the B.B.C. and I.T.A. over the length and breadth of Britain, and about 240 short-distance vision circuits connecting up studios, switching centres and transmitting stations to the main network—the majority of the short-distance circuits being carried by cable. Rapid and extensive extension of the national television circuits is now in progress following the authorization of the second B.B.C. television service on the new 625-line standard (both monochrome and colour). The first phase of this is due for completion in 1966 and involves the provision of 24 main-line channels, with a total mileage of about 2,600, and 85 additional short-distance circuits. In due course the problem of converting the existing 405-line services to 625-line working will arise; greater-bandwidth circuits will be needed, and those circuits which are now carried in cable will in all probability be transferred to radio. Thus we are likely, over the next few years, to see the whole of the main-line vision-circuit network of Britain carried on the new microwave-radio systems.

Mention should be made of closed-circuit television for commercial and industrial purposes. There are at present 140 such circuits in operation, all of them of short distance. Inquiries are received for the provision of longer-distance vision circuits for such purposes, but their very high cost has always deterred the applicants. It is possible that many of the uses concerned will have to adopt some form of slow-scan television system before they become economic.

#### LONG-DISTANCE WAVEGUIDE

Numerous technical articles have been published in the United States, the United Kingdom and elsewhere on the potentialities of the long-distance waveguide. Thus a waveguide about 2 in. in diameter, with repeaters and other associated equipment about every 20 miles, dealing with frequencies of about 150,000 Mc/s, should be capable of providing a bandwidth of 1,000 Mc/s in each direction of transmission, equivalent to 250,000 speech circuits or 200 both-way television channels. At present there is no individual service requirement which waveguides might meet which existing types of coaxial cable and microwave link cannot. The philosophy has been, so far as research and development are concerned, to find some means of carrying vastly increased quantities of data of all kinds

when saturation of the radio spectrum occurs. However, economic studies, necessarily based on rather meagre and tentative data, suggest that a waveguide might break even with other methods of transmission at the equivalent of a need for some 50,000 telephone circuits. The only routes in Britain over which such a demand is likely to be approached—and then not for a very long time—are the London-Birmingham and Birmingham-Manchester routes: the former by about 1975, followed perhaps five years later by the Birmingham-Manchester route.

Much difficulty in bringing waveguides into and through cities and large towns is likely, and serious problems arise in distributing the circuits to the trunk exchanges. The problems could doubtless be solved by using large numbers of small coaxial pairs, and maybe we shall see a fuller development of the small-coaxial systems before the waveguide comes into its own. Development work must have a speed of urgency and necessity if it is to be efficient and stimulating. Development of various modulation techniques for satellite and small-coaxial working leads into those required for use with waveguides, and a more aggressive and fruitful attack on the waveguide problem is probably best planned nearer the need for its use.

#### OVERSEAS COMMUNICATION

Communication with Europe is now generally provided by repeatered submarine cable systems and to a small extent by microwave radio, and presents no real problem today. The more interesting developments arise from the rapidly growing demand for inter-continental communication. Much has already been said at this Institution about the development of short-wave radio circuits suitable for telephony and multi-channel telegraph working, but such circuits cannot compete successfully in quality and reliability with those given by the repeatered submarine cable systems of today. Nevertheless, short-wave radio still has great possibilities in those areas where cables cannot yet be economic because of low traffic demands. Tonight, however, I propose to discuss only repeatered cable systems and radio satellites in any detail.

#### DEVELOPMENT OF REPEATERED CABLE SYSTEMS

The first transatlantic telephone cable system, that between the United States and the United Kingdom, was completed and opened for public service as long ago as 1956, Sir Gordon Radley being able to discuss this in his Inaugural Address of that year. This system of American design provided initially 36 telephone circuits (equivalent to at least 864 telegraph circuits) and used separate unidirectional repeatered cables for each direction of transmission. Within five years of the coming of that system into use, telephone traffic to North America quadrupled. Two developments made the carrying of this increased traffic possible. The first was the development of high-efficiency channelling equipment by the British Post Office, whereby a 3 kc/s channel separation was adopted for transmission over the submarine cable in place of the standard 4 kc/s separation; this increased the number of circuits to 48 with a loss of only 250 c/s in effective transmitted bandwidth. The second used a time-sharing device, T.A.S.I., developed by the Bell Telephone Laboratories in the United States, in which high-speed electronic switching connects a

subscriber only when he is actually speaking. This about doubles the number of telephone conversations which can be carried over the submarine cable. Thus the potential capacity was increased from 36 to 96 speech circuits. After completion of TAT-1, the American Telephone and Telegraph Co. (A.T. and T.) proceeded with a number of similar schemes, including one between California and Hawaii and another (TAT-2) between the United States and France.

For the next steps in ocean-cable telephony we must turn to British development. In 1951, work had been started at the Post Office Research Station at Dollis Hill on a revolutionary type of deep-sea cable aimed basically at eliminating twisting under tension but providing in the process smaller size and lower cost for the same technical performance. Up to that time, deep-sea cable had been traditionally protected by a multiple helix of high-tensile-steel armour wires, essentially to support the weight of the cable when laying in deep water and incidentally to protect it. The new concept transferred the tension member to the centre of the cable. The member consists of two coaxial groups of high-tensile-steel wires having opposite lays and torsionally balanced, with a polythene outer sheath which gives ample protection in deep water, where there is virtually no movement and no danger from anchors or trawls.

In 1957, the British and Canadian Governments agreed to build a "high-capacity" cable system (CANTAT) between their two countries. By this time, the development of the new "lightweight" cable was sufficiently far advanced for it to be used in the deep-water section of this all-British system. Many problems relating to repeaters, the cable and its laying had to be resolved before manufacture could begin. The provision of this transatlantic cable (length 2,100 n.m.), giving a bandwidth of 240 kc/s for each direction of transmission over the one cable, was completed by the target date of autumn 1961, the service being inaugurated by Her Majesty The Queen and Mr. Diefenbaker in December 1961. This system, including the first use of the "lightweight" cable, was a great success and established the pattern of future development not only here but also for America. Without a T.A.S.I. equipment, the capacity of the cable is 80 telephone circuits or their equivalent.

Before the new designs for CANTAT had been proven, the Commonwealth Governments agreed in 1959 to provide a "round-the-world" telephone-cable system in which CANTAT would form the first link and the pattern for the whole system. The same year, Britain, Canada, Australia and New Zealand agreed to proceed, immediately after CANTAT, with a trans-Pacific cable (COMPAC), an 8,000 n.m. system from Vancouver to Hawaii (linking with American systems, existing and planned) and thence to Fiji, Auckland and Sydney. All the cable for this system has now been laid. The service from London to Sydney and intermediately is due to be inaugurated in December 1963.

The next stage of the Commonwealth cable (SEACOM), work on which is already in hand, will link Australia with New Guinea and North Borneo and thence, two ways, to Singapore and Hong Kong by 1966. A number of shorter systems also have been constructed on the CANTAT pattern, including the U.S.A.-Bermuda link.

Meanwhile, A.T. and T. development has moved away from the pattern of TAT-1, with its separate cable for each direction of transmission, to a system very similar to the single-cable CANTAT system but designed to have a bandwidth of 384 kc/s in each direction; this uses armourless cable, basically the same as the British cable but with novel features, some of which will be reflected in a new British version now being evolved for systems of much greater capacity. The new A.T. and T. system was first used between Florida and Jamaica in 1963; and TAT-3, a direct cable between New Jersey and Cornwall, will come into service this year. A similar cable may well be laid between New Jersey and France in about 1966, after the completion of a trans-Pacific link from California to Japan via Hawaii. There will be an exchange of "indefeasible rights of user" circuits, in the Japan and Australia cables, by the A.T. and T. and the Commonwealth partners.

Enough has been said to illustrate the extent of the development and provision of world-wide repeatered submarine-cable systems, and should it be wanted, a further design for a new British system exists providing for a bandwidth of some 1.08 Mc/s in each direction (equivalent to 360 telephone circuits) over a single cable as long as 4,000 n.m., involving some 400 repeaters using feeding voltages of 12 kV at each end. Such a system would, like its predecessors, use thermionic valves and could be ready in 1966.

Transistor reliability has probably reached the stage where it exceeds the best obtainable from valves. Transistors also offer prospects of greater bandwidths and reduced terminal feeding voltages; they are, however, more susceptible to damage by voltage surges set up when a cable is broken, e.g. by a trawler. A.T. and T. have already announced plans for a system using germanium transistors and providing 720 telephone circuits on one cable, though this will not be ready for some years. The first use of a British transistorized system will be between the United Kingdom and Belgium in 1964; though only a very restricted application, this will provide transmission up to 4.3 Mc/s. It seems probable that transistor systems capable of transmitting frequencies up to about 10 Mc/s will be possible before 1970, and current British plans have this as an objective; such a system could give unrestricted television facilities if required.

It is interesting to note how confidence in the active equipment for submarine cable systems has increased. TAT-1 has 51 repeaters in each cable, with an overall maximum gain of 3,200 db, and a feeding voltage of 2 kV at each end; the longest existing section of the Commonwealth cable has 118 repeaters, 6,700 db gain and 6.3 + 6.3 kV; TAT-3 has 181 repeaters, 8,700 db gain and 5.5 + 5.5 kV; in each case, the standard deviation of circuit equivalent is maintained to within 0.5 db.

#### SATELLITE COMMUNICATION

Lecturing to the Electronics and Communications Section in December 1958 and speaking of the need for a very wideband transmission path, I was merely able to refer to the possible use of artificial satellites, either as passive or as active relay points for a microwave system across the Atlantic. At that time, man had just demonstrated his ability to put artificial satellites into



orbit around the Earth. By the time I repeated this lecture in March 1961 to members of this Institution in Coventry, I was able to quote the successful transmission in August 1960 by the Bell Telephone Laboratories of speech, music and facsimile signals from California to New Jersey, U.S.A., by reflection of 960 and 2,000 Mc/s radio waves from a 100 ft diameter balloon satellite, known as Echo I. Speech and music signals transmitted on 960 Mc/s from New Jersey were received at the Jodrell Bank radio-astronomy station on its 250 ft diameter radio telescope, and also by scientists and engineers of the Ministry of Aviation and the British Post Office at the Royal Radar Establishment, Malvern. Thus by August 1960 the Atlantic had been spanned by means of a communication satellite, albeit by simple reflection from its surface. Today we all know of the successful tests using the American "active" satellite TELSTAR, which was launched in July 1962, and indeed most people have seen in their homes live television pictures transmitted from the other side of the Atlantic. Satisfactory results were quickly achieved in transmitting across the Atlantic by this means telephone, television (monochrome and colour), telegraph, facsimile and data signals. These successes were repeated in December 1962 when the American satellite RELAY was launched, and later with TELSTAR II.

An early decision by the Post Office to provide its own experimental satellite ground station at Goonhilly Downs in Cornwall has enabled our engineers and scientists to play a most active part and gain invaluable experience in these early formative stages of satellite communication. Goonhilly Downs station, of world-wide fame, is original in design and construction. It cost some £750,000 and was completed within one year of obtaining access to the site, in time for the very first tests with TELSTAR I. In this work we have been well supported by British industry, and much credit must be given to them for enabling us to achieve what we have in fact achieved.

Clearly, satellite communication is feasible, but it would be unwise to assume that fully operational systems will be immediately available, although they may well become practical realities within the next few years. Many technical problems have still to be solved

before we can be sure that satellites will have an acceptably long life in the hostile environment of space. Many questions arise. What type of orbit should be used—random, polar, equatorial, synchronous and so on? Do we evolve from one system to another? How does the time by which such satellite systems could reasonably be expected to become available match up with traffic needs? How are the needs for frequencies to be met? How do the capital and maintenance costs compare with those for submarine repeatered cables and short-wave radio? When do they become viable? How will they be organized operationally? These and many other questions like them are waiting to be answered—but not, I hasten to add, by me tonight—and soon. Whereas a submarine cable system can so often be developed and exploited effectively by co-operation limited to two countries, a satellite system essentially needs the co-operation of many. Valuable exploratory discussions with other Governments and Administrations are taking place as a matter of urgency, and should ensure that the system which is constructed will be the one which best serves the world's needs. Maybe it is too early to say just what part satellite-communication systems will play, but few can doubt that short-wave radio, submarine cables and satellite radio all have their own proper complementary part to play in world-wide communication of the future.

#### CONCLUSION

For this Address, I have chosen to talk about some important developments in world-wide communication against the background of complete automation of the public service and the need for integration of facilities for the various kinds of service required. In doing so, I am, however, only too conscious of so much other development which I have omitted—work which is less spectacular but nevertheless plays such an important and essential part in the proper deployment of expenditure for maximum return and making the service viable—simple developments, minor changes in design, new methods of doing things, which nevertheless, because of their extensive and repeated use, can effect significant economies and achieve that greater productivity from each and every one of us.

---

## Books Received

"Wireless World Diary, 1964," T. J. and J. Smith, Ltd., in conjunction with *Wireless World*. 77 pages of reference material plus diary pages of one week to an opening. 5s. 6d.

The reference section of this diary contains the addresses of over 150 radio and allied organizations in this country and abroad, tabulated details of the world's television standards, dimensions for the elements of aerials for television and v.h.f. sound broadcasting, tabulated base connections for over 700 current receiving valves, channels and frequencies of U.K. television and v.h.f. sound broadcasting stations, graphical and letter symbols used in radio, and a variety of other information.

"Electric Circuit Theory." Second Edition. F. A. Benson, D. Eng., Ph.D., A.M.I.E.E., and D. Harrison, M.Eng., Ph.D., A.M.I.E.E. Edward Arnold (Publishers), Ltd. viii + 402 pp. 323 ill. 35s.

The first edition of this book was published in 1959 and was reviewed in the July 1960 issue of this Journal (Vol. 53, p. 117, July 1960). The second edition, which has now appeared, is virtually a reprint of the first edition with the addition of a chapter on "Transistor Circuits." This 30-page chapter deals with equivalent circuits for the three basic circuit configurations, transistor amplifiers, high-frequency effects, transistor oscillators, and the hybrid or *h* parameters. The opportunity has been taken to make a few minor modifications and corrections to the original text.

# A New Watch Receiver—Receiver, Watch, No. 8T

F. E. TROKE, A.M.I.E.E.†

U.D.C. 621.395.623.62:621.395.721.7

A watch receiver has been developed for use with 700-type telephones. A feature of the new receiver is that it incorporates a gravity switch so that there is no unnecessary loss of received power when the watch receiver is not in use.

AS part of the modernization program of subscribers' apparatus, a new and more efficient watch receiver (Receiver, Watch, No. 8T) has been introduced. It is provided as an addition to a standard 700-type telephone instrument when a second receiver is required, either for use in noisy situations or to enable a second person to listen, e.g. to make shorthand notes, and is hung on a small bracket projecting to the rear of the telephone (Fig. 1). This bracket, which is of stainless

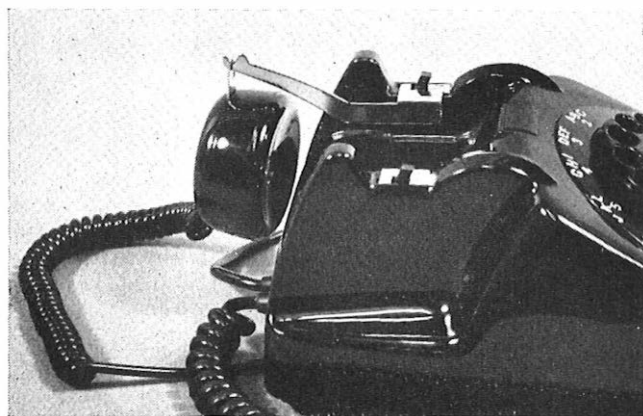

FIG. 1—WATCH RECEIVER AND BRACKET ON 700-TYPE TELEPHONE

steel, replaces the right-hand escutcheon plate in the cradle rest.

The complete watch receiver consists of two mouldings to encase the receiver capsule, a stainless-steel eye to hang it on its hook, and a coiled, extensible, plastic-covered cord. The case is a one-piece moulding in methyl-methacrylate with a moulded thread to accept the earcap, which is the standard item as used on the telephone handset. The cord-entry socket is moulded to provide the same type of bayonet fixing for the cord grommet as that used on the handset, although reduced in size. The receiver capsule is the same type as that used in the standard handset (Inset Receiver No. 4T), and since it is connected in parallel with the existing receiver in the handset the available received power (apart from the slight mismatch loss) is shared equally between them.

To avoid unnecessary loss when the watch receiver

†Subscribers' Apparatus and Miscellaneous Services Branch, E.-in-C.'s Office.

is not being used, and to prevent it emitting received speech when on its hook, the eye has been designed to provide a gravity switch within the watch receiver, the weight of which operates the switch. The eye, instead of being fixed rigidly to the outside of the case as in earlier designs, passes through a slot in the case and is extended to form a slide-bar which is free to move longitudinally for about  $\frac{1}{4}$  in. It is normally drawn into the case by a hairpin spring, but when the watch receiver is hung upon its hook its weight overcomes the force of the spring and the slide-bar is partially withdrawn from the case, i.e. when the eye engages with the hook the watch receiver slips down the slide-bar. This movement of the slide-bar operates the gravity switch.

The inner end of the slide-bar is wedge-shaped and positioned between two nylon rollers on the ends of two wire contact-springs mounted in the pillars for the cord termination (Fig. 2). The two contact-springs bear upon

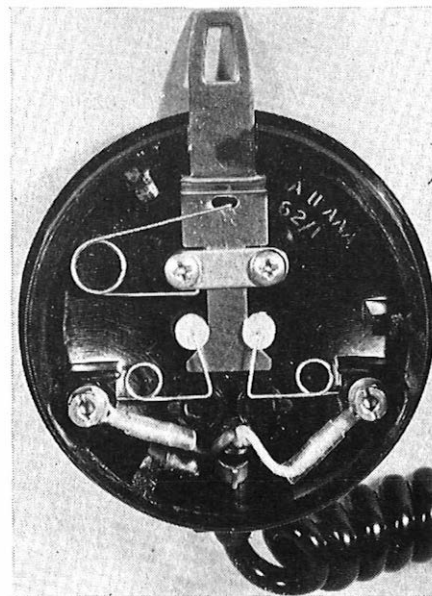

FIG. 2—CASE OF RECEIVER SHOWING GRAVITY-OPERATED SWITCH

two special nuts on the receiver capsule to make electrical contact. When the slide-bar is partially withdrawn the rollers ride up the two inclined planes and the springs are lifted off the terminal nuts on the receiver so interrupting the circuit. As these contacts are not "wetted" by the flow of a direct current and heavy contact pressures cannot be obtained to operate the gravity switch because of the small force available from the weight of the receiver, both the terminal nuts and the wire springs are gold plated to provide reliable contacts.

# The Manufacture of Earthenware Ducts

D. W. STENSON, B.Sc.(Eng.)†

U.D.C. 666.64:621.315.232

Earthenware ducts form by far the greater part of the Post Office underground-cable conduit system. Although the basic stages in the manufacture of earthenware have remained unaltered for centuries, the techniques employed have changed considerably, and the methods at present in use for the manufacture of Post Office designs of duct are described.

## INTRODUCTION

**I**DEALLY, an underground-cable conduit or duct should possess the following main properties. It should have a smooth low-friction bore, adequate strength and durability, it should be inert to the cables that it will contain, and it should be easy to lay, with sufficient flexibility to permit deviations in the line of the trench. It should be watertight, or at least resistant to silting, and, finally, its cost should be competitive. The glazed earthenware duct possess most of these properties to a greater extent than any other available conduit at a comparable price. For this reason the Post Office has been using earthenware ducts for over half a century as the main basis of its underground-cable conduit system.

The present form of duct, with a moulded-earthenware socket and Stanford-composition spigot and socket linings (Fig. 1), has been used for most of this time. Such

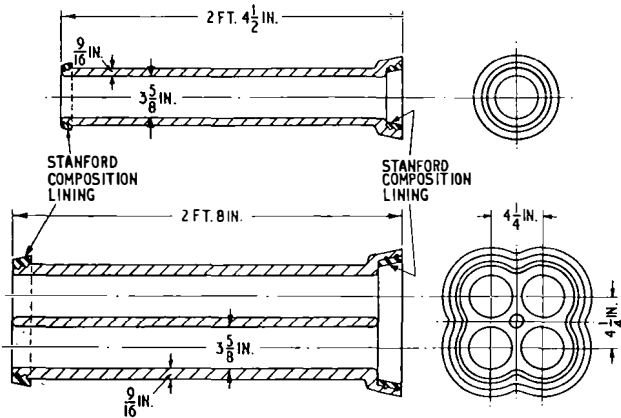

FIG. 1.—POST OFFICE TYPE DUCTS

changes as have been made have been of a dimensional nature dictated chiefly by current requirements and economics. As with any design used in great quantity for many years, over-familiarity tends to lead to exaggeration of known shortcomings, and this is true of the earthenware duct. The fact remains, however, that throughout this time there has been no serious competitor, and due to the nature of the raw material alternative designs present considerable problems. Currently, some 4,000 bore-miles are used annually in the form of single-way, 2-, 4-, 6- and 9-way ducts, compared with only 60 bore-miles of all other types, including the small-bore service ducts.

The basic stages in the manufacture of earthenware, winning, preparing, extruding or moulding, drying and

firing, are much the same as those that have been employed since the first pottery was made, but the techniques have changed considerably. In this article it is proposed to give a brief outline of the methods at present used in the manufacture of the Post Office designs of earthenware duct.

## RAW MATERIAL

The raw material is clay, which occurs in varying form over a large area of the country. The original clay was produced by the natural weathering of granite rocks and is a mixture of several materials. The clay mineral is kaolonite, or chemically-hydrated aluminium silicate. It is this material that gives the clay its plasticity when mixed with relatively small proportions of water, and its important refractory properties. Quartz and mica in a finely-divided form are also present as the result of the weathering process. The former is relatively inert, but the mica is of some importance since it acts as a flux during the firing process. Clays of this general form occur as china clays in South West England and ball clays in Devon and Dorset; these are used mainly by the pottery industries. The vast majority of clays, however, are less pure, and, depending upon the age and conditions under which the deposit was laid down, contain varying amounts of other organic and inorganic earthy materials. It is these types of clay that are used by the earthenware manufacturer. The "adulterants" present may have desirable or undesirable effects on the firing and finished properties of the clay, depending upon their nature and the amount present. They are also responsible for the varying but characteristic colours of the finished earthenware.

During the firing process a series of relatively complex chemical changes occur. Broadly, these commence with a breakdown of the clay molecule at about 600°C and continue to the formation of glasses in the region of 1,100°C. The resulting material consists of complex crystals bonded together with a glassy substance, and it is upon the size and characteristics of these crystals that the strength and other properties of the finished article depend.

Before passing to the manufacturing processes, mention should be made of another characteristic of clay, —its high shrinkage on drying. This is clearly illustrated by the familiar summer ground cracks in a clay district. Shrinkage would perhaps cause no difficulty if the amount were consistent, but, due to the variable nature of the clays used in the manufacture of earthenware products, some problems do arise, especially as such variations may occur even within one manufacturer's clay pit. Some further shrinkage also occurs during firing. To reduce and control shrinkage and warping during both drying and firing a material known as grog is mixed with the raw clay before extrusion.

Grog, or red grog as it is sometimes called, is made by grinding broken duct to a fine powder. The burnt clay is unchanged by the second firing, thus its inclusion in the clay tends to restrict shrinkage. In some instances, the coarser residue from the screening of a ground raw clay is also used as a proportion of the grog. This is

†External Plant and Protection Branch, E.-in-C.'s Office.

usually referred to as green grog and may contain small particles of gannister, or ironstone, etc. It has a lower shrinkage value than the finer clay and thus to some degree assists in the reduction of shrinkage and speed of drying. However, its inclusion tends to increase the porosity of the fired earthenware.

With certain clays it may also be necessary to add other materials to the grog to make good deficiencies that would otherwise result in an unsatisfactory end-product. Sand, for instance, may be added not only to control shrinkage and warping, but also to provide the silica necessary for partial vitrification of the clay. An excess of sand, however, can lead to brittleness. Lime is another additive necessary with some clays as a fluxing agent. Again, an excess of lime can be troublesome, and since the amount required is very small it is often added in the water used at the mixing stage rather than as a constituent of the grog. In general, however, earthenware clays are chosen for their natural firing properties.

#### PREPARATION OF THE CLAY

The clay is won from open pits, the top layer of soil having first been removed. Digging is usually carried out with mechanical shovels or excavators and the clay transported to the adjacent works by conveyors, light railway or lorry. At the works the clay is emptied into a hopper serving the grinding pan, which is usually of

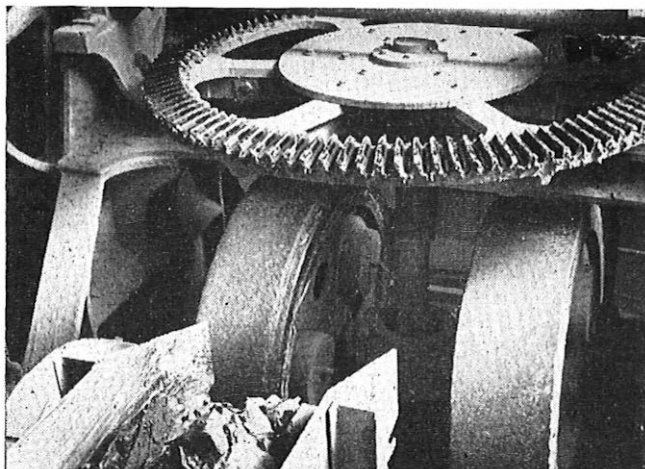

FIG. 2—CLAY GRINDING

the type illustrated (Fig. 2). This consists of two heavy rotating wheels that roll and grind the clay into a fine granular form, allowing it to fall through the perforated bottom of the grinding pan. The resulting powder is relatively dry and loose, but if firmly compressed it can be moulded in much the same way as the original clay.

The ground clay is often screened in rotating cylindrical sieves (usually a No. 10 sieve or smaller) to remove the coarser material so that, in general, only sufficiently-fine material is allowed to go on, the coarser material being returned to the grinding pan for further grinding. Sieves of this type have a tendency to clog, and modern screens use a sieve that is electrically heated and magnetically vibrated. The heating partially dries any material tending to adhere to the sieve so that it is more readily shaken free, thus avoiding clogging. The sieved material is stored in hoppers ready for use.

The clay as excavated is very stiff and does not vary greatly in water content even in wet weather; thus the process, so far, is designed to work the clay without drying or the addition of water.

From the hopper the ground clay passes to the mixing and extruding machines (Fig. 3). Here about 10 per

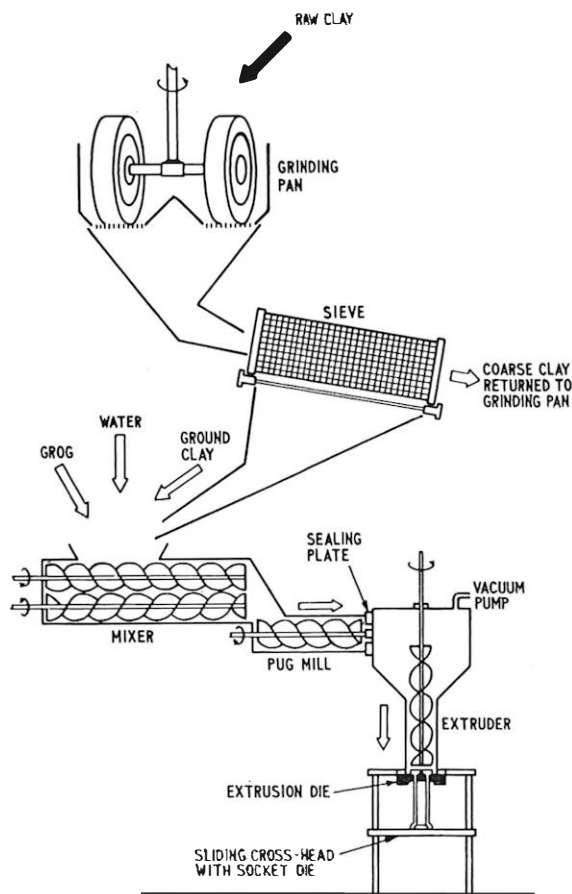

FIG. 3—DIAGRAM OF MIXING AND EXTRUDING MACHINES

cent of grog (including sand, etc.) is added together with just sufficient water to permit the clay to be kneaded into a plastic state by the contra-rotating double screws of the mixer. The proportion of grog used varies with the type of clay and earthenware to be produced, e.g. a 9-way duct will generally require more than a single-way duct. The double-shaft mixer feeds directly into a pug-mill. The pug-mill consists of a large coarse-pitch screw rotating inside a cylinder and works in much the same way as the domestic mincer or a sausage machine. The clay is thus compressed and forced directly through a sealing plate into the sealed hopper at the head of the extruder. The inside of the extruder is maintained at a fairly low pressure by vacuum pumps in order to extract air from the clay; the presence of air may cause the burnt clay to be porous and weak. The sealing plate is a perforated metal plate or it may be in the form of a narrow annulus. With either type, the clay is forced through the openings so that the vacuum in the extruder hopper is maintained by the body of compressed clay in the feeding pug-mill.

In an alternative arrangement the pug-mill does not

feed the extruder directly but the compressed clay is cut off into suitable pieces before being passed through a de-aerating machine and then to the extruder. Again, with some clays, de-aerating offers no advantages and the process may be omitted.

#### EXTRUSION

The extruder operates in the same way as the pug-mill. Normally, however, the screw is arranged vertically so that the clay is compressed and extruded through the die near the bottom of the machine (Fig. 4). Since

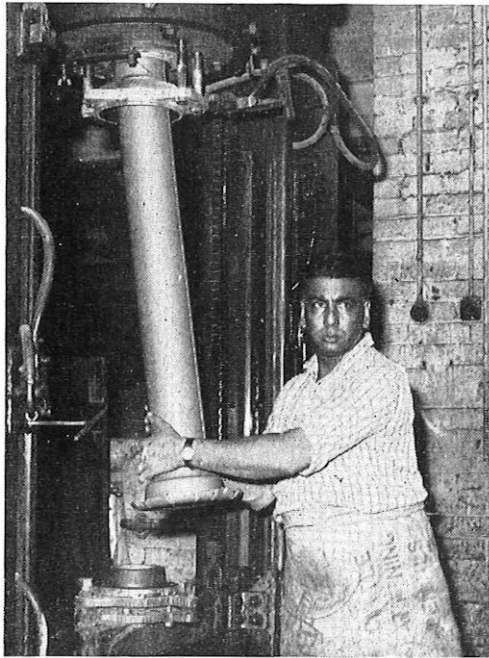

FIG. 4—EXTRUSION OF DUCT

extrusion is not a continuous process it is necessary to arrange for easy stopping and starting of the screw, and this is usually achieved by the inclusion of a clutch mechanism in the drive to the screw.

The die fitted to the extruder can be changed to suit the type of earthenware required. It consists essentially of a metal plate, usually a casting, with an opening cut through it having the shape of the article to be extruded. The plugs forming the bores of the duct are held by a steel web affixed to the body of the die. Thus the clay flows around the web before emerging through the opening in the die. The die includes on its underside a mould for the exterior of the socket of the finished duct. A vertically sliding platform or cross-head carries the mould for the interior of the socket. The exterior socket mould is loosely fixed to the underside of the die so that, except when the cross-head is locked in the upper position, there is a narrow space between the die and the mould.

At the start of the extrusion process the platform is held hard up to the underside of the die. Clay is extruded through the die into the socket mould, which, when filled, allows some of the clay to escape through the bottom joint of the socket mould as a thin "flash". This flash may be used to operate a switch controlling the cross-head locking mechanism. When this occurs, the platform is released and moves downwards so that

the barrel of the duct is extruded from the die. When the desired length has been extruded the screw feed is stopped and a wire passes between the socket exterior mould and the die, thus cutting the duct to length. The duct is then removed from the platform and the process repeated.

Single-way ducts are normally lifted off the inner socket mould, but, due to the weight of the larger multi-way ducts, a number of inner-socket moulds are used, each mould then being removed from the machine with the duct and a new mould fitted to the platform before the extrusion process continues.

The extruded duct is normally dark grey in colour, with a smooth, almost polished, surface. It contains about 14 per cent of water, but is quite firm and can be handled without distortion providing reasonable care is taken. The duct is trimmed and finished either by hand or machine, or both. The socket flash is removed and the interior of the socket scored to provide a key for the Stanford lining. A similar key may also be provided at the spigot end. The inside edges of the bore at both ends are radiused. The finished ducts are then stacked on pallets and passed to the drying rooms or sheds.

#### DRYING

In the drying rooms gentle heat is used to remove the moisture from the duct. This is an essential preliminary to the firing since, at the temperatures involved in firing, water contained in the material would be rapidly turned into steam and would splinter or crack the duct, making it quite useless. Drying time varies greatly with the size of the duct. For example, a single-way duct requires one day whereas a 9-way duct will require about 14 days.

It is important during the drying process to avoid distortion due to uneven drying, and the process is thus relatively slow and carried out under uniform air-flow conditions. The drying sheds have slatted or perforated floors that permit the circulation of warm dry air up through the ducts. The ducts are stacked closely together, and in a large shed each batch may be protected on all four sides by temporary screens. Even so it is necessary to turn the outer ducts of the batch at regular intervals, or uneven drying might result, causing bending and distortion of the ducts.

A more modern method uses a bank of drying chambers or ovens with a system of damper-controlled inter-connecting flues. With this method the chambers are filled with stacked ducts and closed. Dampers are then opened so that the warm damp air from the remaining chambers passes into the newly-charged chamber. The warm dry air passes initially into the chambers containing nearly dried ducts and from this into chambers with successively wetter ducts until the last chamber containing the new charge is reached, when the cooler moist air is discharged to the atmosphere. Thus, as the charge in each chamber is dried and ready for removal, the flue dampers are closed to seal the chamber from the incoming dry-air stream which is diverted into the preceding chamber where the ducts are nearing the end of their drying period. The inlets and outlets for the air stream are therefore circulated progressively around the bank of chambers.

The dried duct is quite hard, the plasticity of the clay having disappeared in the drying process. In fact, if subjected to a blow or heavy pressure the duct, in

this state, would break rather than deform. The colour changes to a light grey, almost white, and for this reason the dried ware is often referred to as being "white hard".

#### FIRING

When the ducts are completely dry they are removed from the drying sheds or chambers and are ready for firing in the kiln. Perhaps the most commonly used kiln is the circular down-draught type. This is a brick structure circular in plan and having a domed roof, with firing hearths at intervals around the circumference (Fig. 5). The inside of the kiln is lined with refractory

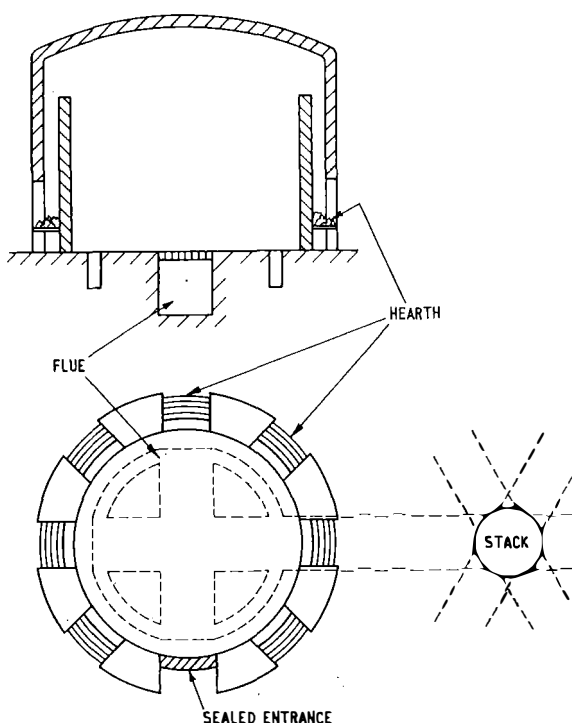

FIG. 5—DIAGRAM OF CIRCULAR DOWN-DRAUGHT KILN

bricks and has an inner wall reaching to within a foot or so of the underside of the roof. The floor within this inner wall is perforated and gives access to an underground flue connected to the chimney. As a rule the chimney is arranged to serve a number of such kilns, which are built around it with the flues radiating like the spokes of a wheel from the base of the stack. It will be seen, therefore, that the hot gases from the fire hearths around the kiln are deflected upwards to the roof by the inner wall and then pass down through the earthenware, stacked on the floor of the kiln, into the flue and away through the chimney.

The manner in which the earthenware is stacked is of considerable importance if the flow of hot gases through the kiln is to be evenly distributed and all the earthenware in the kiln burnt uniformly at the same temperature. Partly for this reason, it is often found that more than one type of duct is fired in the kiln at one time. Firing is one of the most expensive operations in the manufacture of ducts, and great care and skill are required to stack the maximum amount of earthenware in a kiln. The ducts should not touch, and the stack has to remain stable throughout firing. A collapsed

stack would require a considerable amount of labour to clear and could ruin the kiln.

After stacking the white-hard ducts in the kiln the entrance is bricked up and sealed. The fires are lighted and the temperature raised to about 1,100°C, usually in a number of distinct stages or steps. Initially the temperature is raised to about 550°C as quickly as the clay will permit. This is known as the "water smoking" period, since all remaining water in the clay is driven off during this period. The temperature is then allowed to rise more slowly to about 850°C, whilst all carboniferous material and sulphur in the clay is oxidized or burnt out. Once this process is complete the temperature can be raised more quickly to about 1,000°C, followed by a slow rise to 1,100°C during the so-called "soaking period" whilst the vitrification process is completed. The earthenware is then cooled as quickly as is possible without fracturing. The time required for these different phases varies considerably with the types of clay and product. For single-way ducts the total firing period is about 5 days, whereas multiway ducts take somewhat longer since the heating and cooling stresses are more severe and, thus, firing must proceed more slowly.

Glazing is usually carried out at the commencement of the soaking period by throwing common salt on the fires. The resulting fumes passing through the hot earthenware attack the surface of the clay, fluxing it to form a glass surface on the duct. When sufficiently cool, the kiln is opened, and the burnt ducts, now having their well-known appearance, are removed.

This type of kiln has been standard for many years and is still much used, but alternative designs have been developed to reduce the firing and labour costs. One new form of kiln closely resembles in general principle the drying ovens previously described. The kilns are built together in a rectangular block containing 16 compartments. Each compartment or oven is provided with a firing hearth behind a curtain wall and in the body of the oven there is a perforated floor. A system of flues with dampers connects the underside of each hearth to the perforated floor of the adjacent oven. The hearths are fed with either coal or oil through small firing holes in the roof of the kiln. Only one oven is fired at a time. The air supply for this is pre-heated by drawing it in through the ovens containing burnt earthenware, from the coolest, where the ducts are nearly ready for removal, through successive ovens until it passes through the oven where firing last took place, and then into the oven being fired. The hot gases from this oven are then used to pre-heat the earthenware awaiting firing in succeeding ovens, and are finally exhausted to the chimney. It will be seen that with this type of kiln greater direct use is made of the available heat than with the traditional type previously described.

Another type of kiln is the tunnel kiln, which is also used in the pottery industry. This kiln is built in the form of an open-ended tunnel some 100 yd long. It may be heated with coal, but oil burners or gas jets set in the wall of the tunnel are more common, the exhaust gases passing out through a flue in the floor. The ducts are stacked on steel-framed trolleys or cars having a platform of refractory bricks, and these trolleys are moved on rails through the tunnel from one end to the other at the rate of approximately 12 ft/hr. The temperature gradients along the tunnel are arranged so

that, during the progress of the trolleys, the earthenware experiences a firing pattern similar to that already described, the maximum temperature of 1,100°C being reached in a region a little beyond the centre of the tunnel, the earthenware emerging at the far end of the tunnel at a temperature near 200°C. This may seem rather hot, but by the time the trolley has completed its traverse to the unloading platform the earthenware is sufficiently cool to handle.

In the type of kiln just mentioned a salt glaze may be used, but there are difficulties due to the continuous nature of the kiln; thus, a ceramic glaze similar to that used in the pottery industry is often employed. The glaze, applied by a separate operation prior to firing, is a mixture, or slurry, in water, of finely ground borax, silica, lead and sodium salts, and other constituents. It is usually applied by spraying the bore only of the duct during the trimming process after extrusion. The constituents of the glaze are thus dried on to the duct during the subsequent process and during firing they melt and flux to give a glass-like coating to the surface of the clay. A glaze of this type has an advantage from the cabling viewpoint. With the salt glaze, results tend to be variable and a great deal depends upon the skill of the operator both when stacking the ducts in the kiln and during firing. Thus, with salt-glazed earthenware it is economically desirable to accept a small proportion of "dry" or partly-glazed bores which give higher cabling frictions, whereas a ceramic glaze permits better control and should always be perfect.

#### LINING AND FINISHING

It will be appreciated that the tolerances to which earthenware clays can be worked are rather greater than those common in most other manufacturing processes. Apart from shrinkage problems, the material is extremely abrasive, and as a result, if the extrusion dies are to have a reasonable life, a fairly wide variation in dimensions must be permitted. Tolerances of  $\pm\frac{1}{8}$  in. and greater, depending upon the dimension to be considered, are not unusual. It will be apparent, therefore, that it is impracticable to manufacture earthenware ducts with a close-fitting joint. For sewage work the problem is overcome by cement mortar grouting the joints during laying. This is a tedious and costly operation and for Post Office work the same standard of watertightness is not usually required. Use is, therefore, made of the Stanford joint.

The duct is set vertically in a metal spigot mould and a socket mould is fitted. A compound made by boiling a mixture of tar, sulphur and sand or crushed burnt earthenware is then poured hot into the moulds. When cool the compound sets hard and adheres to the spigot and socket ends of the duct, sufficient key having been provided either by grooving the duct prior to firing or chipping away the glaze afterwards. It is a characteristic of the lining material that it moulds well with very little shrinkage. Thus with suitable devices to centre the duct in the lining moulds, much of the variation due to earthenware tolerance is eliminated and a well-fitting joint with optimum bore-centre alignment is obtained. Further, with the simple application of a soft jointing compound on site, it is, with good laying, practicable to obtain a silt-free, if not watertight, track.

The actual form of the lining machine varies from the simple hand-operated type to a fully automatic multi-

head machine. In the simplest case, with single-way ducts, the spigot die may be set on the floor and the socket die fitted by hand. Optimum alignment of the lining with the bore centre is the main consideration, since the linings provide a spherical mating surface. With multiway ducts, however, this type of ball-and-socket joint is not practicable and the mating surfaces are given a plain taper. It is, therefore, necessary to design the lining machine so that the spigot and socket linings are both parallel and concentric if the resulting track is neither to tilt nor twist. The socket die may be carried on a cross-head between two rigid vertical guide columns or, as in the automatic machine shown in Fig. 6, each socket lining is held by a headstock

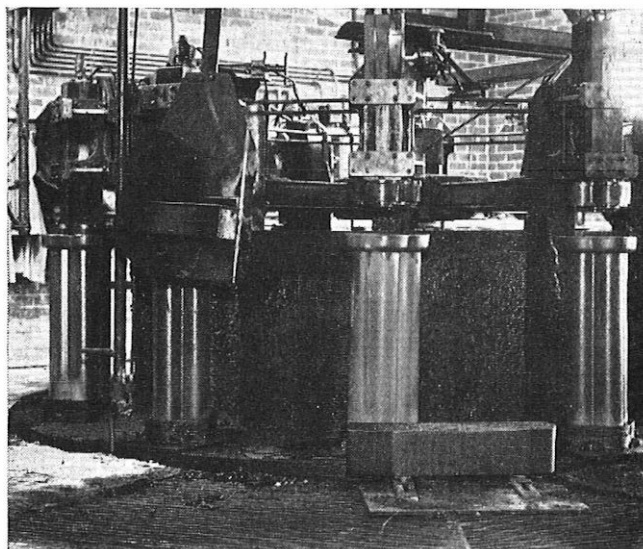

FIG. 6—AUTOMATIC LINING MACHINE

sliding on a large machined vertical bed similar to that of a lathe.

In this last type of lining machine, the whole machine rotates. The operator places a new duct on the spigot die as it passes him. As the machine rotates the socket dies are lowered automatically into the duct socket, and the lining composition applied. When this composition has set, the socket die is lifted ready for the finished duct to be removed; this occurs as the machine completes one revolution. The finished duct is removed to the stack yard for final inspection and to await despatch to site.

#### CONCLUSIONS

It will, perhaps, have been appreciated from the opening remarks and later discussion that progressive improvements in the design of earthenware ducts cannot readily be achieved. Furthermore, with the large quantity used, the price margin available for such improvements is relatively small if the annual bill for ductwork is not to be greatly increased. These factors, coupled with a reasonably satisfactory performance of the existing design, tend to lead to somewhat static conditions. It is therefore not surprising that prior to 1958 no rigid dimensional specification existed for Post Office multiway ducts, and slight variations in dimensions and tolerances existed between different manufacturers' products. This did not, in general, lead to difficulty since ducts for a particular work normally come from one manufac-

turer. However, instances could and did occasionally occur where difficulties were experienced in using ducts from two or more sources. It was decided therefore to tighten up Post Office requirements for all earthenware ducts. This apparently simple step, however, due partly to the nature of the item, presented considerable difficulties and the standardized duct was only achieved after much work and discussion with manufacturers.

However, development of ducts is not static, and other pipe materials, in particular plastics, are now presenting a potentially serious challenge to earthenware. Prices and techniques with these alternatives could, in the not too distant future, offer an underground-cable conduit system with advantages over earthenware and at comparable cost. A great deal of work remains to be done, however, before radical changes could be made.

Amongst the advantages offered by the new duct materials are improved rodding conditions and a com-

pletely watertight track. Earthenware on the other hand offers an assured life with a considerable background of experience. With this in mind therefore the Post Office, together with the earthenware manufacturers, is examining the prospects of alternative earthenware designs in an attempt to give this tried and proven material at least some of the advantages of the new types of duct. At this stage it would be foolhardy to attempt to predict future duct standards, but there is little doubt that earthenware duct will continue to have its place in the Post Office underground system.

#### ACKNOWLEDGEMENTS

The author would like to thank various colleagues and manufacturers for their assistance during the preparation of this article, in particular Mr. O. H. Smith, of the Hepworth Iron Company, Ltd., who also supplied the photographs.

---

## Book Reviews

"Telecommunications." E. H. Jolley, O.B.E., C.G.I.A., M.I.E.E. Weidenfeld and Nicolson (Educational), Ltd. 144 pp. 26 ill. 9s. 6d.

This book is one of the publisher's "Young Engineer" series designed to present a library of informative books for young people from 13 to 15 years. The author is well known in the telecommunication world and was Staff Engineer, Telegraph Branch, E.-in-C.'s Office. His wide experience in the Post Office has enabled him to write a most interesting little book which can truly be said to start with lodestones and to end with satellite communication. It is a brave attempt to cover such a wide field and includes such diverse subjects as telegraphy, telephone switching, line transmission, radio systems, submarine cables, etc.—in fact the lot. Naturally, a book of this breadth and for this class of reader is only an introduction to the subject, but it is a very readable little book, does not overdo the history of the subject, and describes in as easy a manner as possible the present usage in the wide field of modern communication. It fulfills a requirement that many youths nowadays feel the need of, that is, some general description of a subject which they might read when they are thinking of making a career in the scientific or engineering field and do not know which branch they should choose. This book will enable them to obtain a very good idea of modern communication and can be well recommended both to youths—and their fathers.

J.R.

"Elements of Mathematical Statistics." J. F. Ractliffe, M.Sc. Oxford University Press. x + 202 pp. 27 ill. 25s.

This is yet another elementary book on the mathematical theory of statistics. There are sixteen chapters covering such topics as probability, the binomial, Poisson and normal distributions, quality control, tests of statistical significance and confidence limits, regression and correlation and rank correlation. The chapters contain illustrative examples, and many end with exercises for the reader; answers to these exercises are given. The book concludes with a set of test papers with answers, and eight abbreviated tables which will be useful in the solution of the problems. There is no index.

The amount of space devoted to each topic will inevitably vary from author to author but one wonders if

quality control and statistics applied to the study of defective components have not been given disproportionate weight in an elementary book. The standard of mathematics required to follow the arguments is not very high and proofs, where given, are not always rigorous. Some of the more difficult ideas are stated without proof.

The introductions to the several topics are in general very brief, presumably because the origins of this book were in a course of lectures. Perhaps a few more explanatory pages and slightly fewer examples and exercises might have obviated this defect. The absence of suggestions for further reading is a pity; one would hope that a student having worked through this book would wish to go further.

The book can be recommended for anyone who is attending an organized course on statistical theory at an elementary level and who feels the need for supplementary exercises and a summary of lecture material. The student working on his own will probably prefer a book in which the text is rather less terse.

A.C.C.

"The Nomogram." H. J. Allcock, M.Sc. (Wales), M.I.E.E., M.I.Mech.E., Mem.A.I.E.E., J. Reginald Jones, M.A., F.G.S., and J. G. L. Michel, M.Sc., A.R.A. Sir Isaac Pitman and Sons, Ltd. x + 241 pp. 81 ill. 25s.

Nowadays, anyone wanting numerical results may feel that he must reach out for his high-speed electronic digital computer, but such heavy artillery is not always necessary and there are many jobs for which the simple general-purpose continuous-variable computer—the slide-rule—or the nearly related special-purpose continuous-variable computer—the nomogram—is much more efficient. The latter deserves to be used more widely than it is, but unfortunately the construction of a nomogram does take some time and trouble and the theory required is rarely if ever included in syllabuses.

The book reviewed is the fifth edition of a work which first appeared some thirty years ago. With its help, anyone with a knowledge of mathematics as far as determinants should be able to decide whether its formula can be turned into a nomogram and be able to set about constructing one.

The fifth edition contains additional material on recent trends of development and research (including references), a fuller treatment of the circular nomogram, and minor additions and corrections.

W.E.T.



# Automatic Switching of Inland Carrier-Link Sections of Transatlantic Telephone Cable Systems

R. S. G. WOODING†

U.D.C. 621.395.658:621.395.452:621.395.741

The satisfactory operation of the inland sections of the high-revenue-earning transatlantic circuits has necessitated the development of apparatus to provide automatic switching to alternative paths and thus guard against circuit loss. The design requirements and circuit operation of equipment for this purpose are described.

## INTRODUCTION

THE termination of the TAT and CANTAT submarine-cable systems on the western coasts of the British Isles has resulted in the provision of relatively long carrier links between the submarine-cable terminal repeater stations and the international repeater station and control centre in London. Each of these links is routed in more than one tandem-connected carrier or coaxial system and are subject to interruption. Such interruption may be due to a failure of an item of apparatus or may be accidentally caused by engineering work. Since transatlantic circuits have a high revenue-earning potential, it is obviously important to provide alternative routings for these carrier links and the means for switching quickly from one routing to another to ensure continuity of service.

The merits of various methods of switching are touched upon and the apparatus at present in use is described in outline in the following paragraphs.

## DESIGN REQUIREMENTS

Alternative routing facilities can be, and have been, provided in a number of different ways of varying degrees of circuit complexity and economic advantage.

The simplest method, but unfortunately the most expensive where long multi-circuit links are involved, is to give each link a unique alternative, to feed the traffic signals over both paths by means of a hybrid transformer, and to switch from one path to the other at the receiving end. This switch may be manually controlled by the maintenance staff or it may be operated automatically by deviation from normal of a pilot signal within the frequency spectrum of the carrier link. In practice, a control-pilot signal readily exists in the form of the  $84 + \Delta$  kc/s group reference-pilot signal<sup>1</sup> normally associated with each 60–108 kc/s carrier link. In addition to its simplicity, this method has the advantages of high-speed change-over on the detection of a pilot-signal failure and of having each direction of transmission functioning independently under the control of the receiving end.

An alternative method, and one showing considerable saving in costs, is for two working carrier links to share a common alternative link. However, with this method it is no longer possible to feed the traffic signals simultaneously over both paths, and facilities must be introduced to switch both the transmitting and receiving ends of a link under the control of the latter. The in-

struction to switch at the transmitting end may be given either over a separate signalling path, such as a voice-frequency telegraph circuit, or by an in-band pilot signal in the return 60–108 kc/s link, e.g.  $84 + \Delta$  kc/s or a special 64 kc/s section-pilot signal. Generally, independent operation for each direction of transmission is practicable with both methods of signalling, but by switching both directions together a considerable simplification of circuits is possible. In addition, such operating can be shown to be advantageous for maintenance.

It should be noted that, whatever the method of switching, the alternative link comprises both line plant and transmission equipment and does not carry any useful traffic. Economic considerations are therefore of great importance, and have led to the final adoption of the method utilizing a common alternative link with an in-band control-pilot signal.

The basic requirements may be summarized as follows:

(a) The interruption of revenue-earning circuits should be kept to a minimum consistent with positive operation of the switching circuits involved.

(b) Operation of the switching circuits should be inhibited whenever the alternative link is unfit for service or whenever the actual switching apparatus at one end or the other is in an abnormal state, e.g. a power failure has occurred.

(c) Facilities should exist for the manual control of the switching circuits.

## CIRCUIT ARRANGEMENTS

The basic circuit arrangements for a system between London and Oban, using an alternative link common to two working links, are given in the figure.

Consider the failure of an incoming pilot signal, say, in group A on route 1 at London. Such a failure, normally a rise or fall of about 4 db from the normal level, is detected by a filter-amplifier-detector, and relay MA is operated to disconnect the pilot signal from the transmit side of group A towards Oban and simultaneously to operate the local switching relay, relay W, to connect group A to route 2. At Oban the failure of the received pilot signal on route 1, albeit deliberately introduced at London, is acted upon in a manner identical to that at London and service is restored over route 2. Other contacts of the W relays at both ends of the link transfer the pilot-signal supply and monitor-unit connexions for the alternative link from route 2 to route 1. Similar operations would be required to switch group B from route 3 to route 2.

To minimize the number of switching operations, it is arranged that, after a change-over as described in the previous paragraph and the subsequent clearance of any faults that may exist, route 1 is restored to service as the alternative link. With two working links connected over any two of three paths the number of ways they may be interconnected is six and, with a failure, one of six pos-

†Main Lines Development and Maintenance Branch, E.-in-C.'s Office.

<sup>1</sup>NAULLS, R. W. The Group Reference-Pilot Signal. *P.O.E.E.J.*, Vol. 55, p. 237, Jan. 1963.

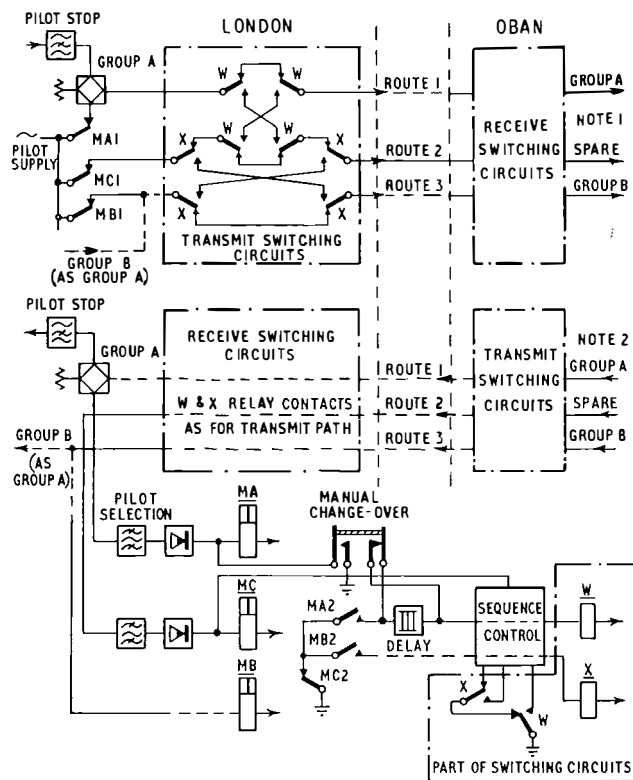

Notes: 1. To monitor and control circuits as shown for London  
 2. From pilot-signal supply circuits as shown for London  
 OUTLINE OF CIRCUIT ARRANGEMENTS

sible switching-relay operations is required to take place. For example, a second failure of group A after the operation previously described would now require the release of relay W. The sequence of the relay operations is determined by the relationships between the working circuits and the three routes prior to a failure and by the setting of a manually-operated sequence control at each end. This is achieved by having supervisory contacts on relays W and X that mark the position the sequence control is to occupy to enable the next operation to be successfully completed.

A failure of the alternative link at any time is detected in a similar manner to the failure of a working link, but the contacts of the detector relay, relay MC, in addition to interrupting the transmitted pilot signal, apply alarm conditions and inhibit local switching operations. This feature is also used to guard against the false operations that would result if the sequence controls at either or both terminals were incorrectly set; the alarm circuit associated with the control operates relay MC and disconnects the transmitted pilot signal.

For manual operation, the MA relay is operated by a non-locking key to disconnect the transmitted working pilot signal and, to keep the interruption to revenue-earning circuits to a minimum, to delay the operation of the local switching relays by a period approximating to the normal recognition and operating times of the distant detector.

#### PILOT-SIGNAL FREQUENCIES

The pilot signal used for the control of the apparatus can be, and has been, the group reference-pilot signal.

This use of the group reference-pilot signal is, however, open to objection, since its main purpose is to provide a maintenance indication of the performance of a carrier link. In addition, the switched section may form but a part of a much longer link, and interruptions outside the switched section would cause unnecessary switching operations. To overcome these objections, a separate section-pilot signal having a frequency of 64 kc/s has been introduced. Suitable filters are provided at the extremities of the switched section to prevent interference with or by any 64 kc/s signal outside that section.

#### MECHANICAL ARRANGEMENTS

The switching apparatus required at each end of three associated links consists of a transmit and a receive relay panel and a common control panel. The filter-amplifier-detectors that determine the operation of the control panel form part of a comprehensive monitoring and alarm facility provided for transatlantic circuits.

All switching apparatus is assembled as 51-type units,<sup>2</sup> the panels for five pairs of working links being accommodated on a single 9 ft rack-side. Generally, the control panels are concentrated at the centre of the rack-side face to provide an easily-visible indication of the routing conditions and any alarm conditions that may exist. Throughout the control panel Post Office standard 3,000-type and high-speed relays are used; in the transmit and receive panels either 2-coil latching relays, designed for use with high-frequency circuits, or electromechanical Ledex rotary switches are used to switch the traffic signals. Both types of switch have the merit of not requiring a holding current, whilst the contact arrangements ensure that crosstalk is kept well within prescribed limits.

#### CONCLUSIONS

The first installations of switching apparatus using latching relays were at London international repeater station and at Oban repeater station and were brought into service in the autumn of 1961 on the TAT-1 and CANTAT circuits. When first commissioned, the performance was such that the time required for the recognition of pilot-signal failure was about 35 ms, and the time that elapsed between such failure and the completion of the subsequent change-over was about 170 ms. However, because the number of short interruptions was found to be greater than expected and was giving rise to an unacceptable number of switching operations, the recognition time of the detector circuits was increased to about 150 ms. A complete change-over may now take something of the order of 400 ms but the number of operations has been reduced considerably.

In general the performance of the apparatus has satisfied the design requirements, but certain difficulties in maintenance were experienced and have been corrected. However, these have been anticipated in the design of the apparatus for the second installation, to be provided for the London to Widemouth TAT-3 links. This second installation will use the Ledex switch units and it is expected that the performance will be in no way inferior to that of the first.

<sup>2</sup>HARRIS, E. T. C., and SPRATT, C. J. An improved Form of Mechanical Construction for Transmission Equipment—51-Type Construction. *P.O.E.E.J.*, Vol. 51, p. 197, Oct. 1958.

# Design and Technology of Silicon Planar Transistors

J. C. HENDERSON, B.Sc., A.Inst.P., and SYLVIA J. WILSON, B.Sc.†

U.D.C. 621.382.3

Silicon planar transistors are becoming of increasing interest as their characteristics and expected reliability can offer considerable advantages to designers. A summary of typical characteristics of these devices and the reasons for their increased life expectancy is followed by a more detailed description of the technology involved in their manufacture.

## INTRODUCTION

THE results of Post Office life tests on germanium alloy transistors were reported in an earlier article in this Journal.<sup>1</sup> At this time it was suggested that silicon devices would prove to be more reliable under adverse ambient conditions for the following reasons:

(a) At the maximum working junction temperature the collector-base leakage current,  $I_{CB0}$ , is much lower than in germanium, so that a larger factor of deterioration during life would be acceptable.

(b) Higher-melting-point materials can be used in the manufacture of silicon devices and thus a higher final temperature can be used to outgas both the device and the encapsulation. In addition, both higher transient power and temperature overloads can be withstood.

(c) The natural silicon surfaces always readily form oxide skins which tend to reduce unwanted leakage paths across exposed p-n junctions.

This last point, along with a change of device geometry, has resulted in a more reliable transistor with a much higher frequency response. This transistor is referred to as a silicon planar transistor (see Fig. 1). As an example

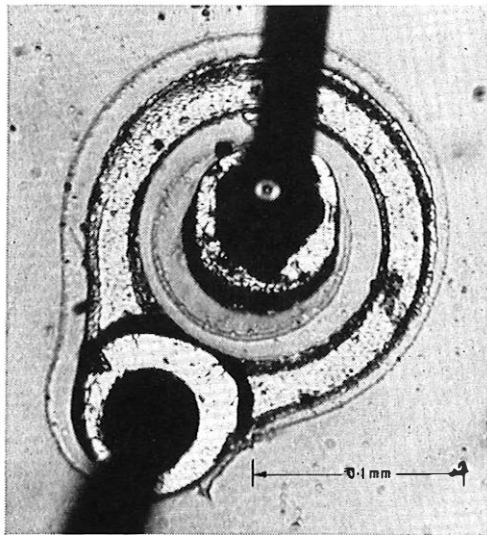

FIG. 1—SILICON PLANAR TRANSISTOR

of one of the range of n-p-n devices that are now available using this structure, the following are typical characteristics:

(a) Power rating up to  $\frac{1}{2}$  watt.

(b)  $f_T$ , the product of  $h_{fe}$  (the current gain in the

common-emitter configuration) and the frequency at which the gain is measured (in the range where the gain is falling at 6 db/octave), is equal to 800 Mc/s.

(c)  $h_{fe} = 50-150$ .

(d)  $V_{(BR)CBO}$ , the collector-base breakdown voltage = 25 volts.

(e)  $I_{CB0} < 10^{-9}$  amp at 25°C.

Life-test results, both in the Post Office and elsewhere, have confirmed the expected increase in reliability from this new transistor structure, but the final judgment cannot yet be made for the particular types of transistor that are electrically suitable for long submarine-cable systems. The main features of the design and fabrication are outlined in the following sections.

## BASIC STRUCTURE OF A PLANAR TRANSISTOR

The two most important features of this device are that:

- (i) the active portions of the transistor are made entirely from one face of a semiconductor slice, and
- (ii) all p-n junctions within the device are protected by a coating of silicon dioxide ( $\text{SiO}_2$ ).

A cross-section through a silicon n-p-n planar device, (see Fig. 2) shows that, where the p-n junctions emerge at

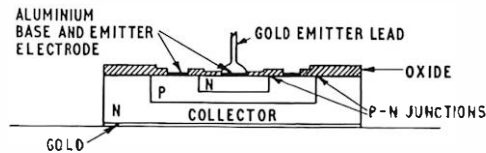

FIG. 2—SECTION OF SILICON PLANAR N-P-N TRANSISTOR

the surface of the slice, a thin layer of oxide, approximately 1 micron ( $10^{-6}$  metres or  $1\mu\text{m}$ ), covers the surface and thus protects these vulnerable regions from the effects of surface moisture and contaminants.

## SEQUENCE OF MANUFACTURE

Thin slices of single-crystal, n-type silicon are oxidized and then covered with a varnish-like substance, known as "photo-resist." This resist has the property of being hardened by ultra-violet (u.v.) radiation and is thus able to withstand the action of acids.

A photographic mask defining the shape and position of many hundreds of transistors is placed in close contact with one side of a slice so that after irradiation the unexposed areas can be dissolved away to reveal windows through which the oxide is exposed. The oxide in these windows is then etched away, the remaining resist removed and, at a high temperature, a p-type impurity is diffused into the exposed areas of the underlying silicon slice. At the point under the window where the p-type and n-type impurities are balanced a p-n, collector-base, junction is formed. A further oxide coating is now grown over the whole surface and an emitter-base junction is formed within the first diffused

†Post Office Research Station.

area by using a second photographic mask and repeating the photo-resist, etching and diffusing techniques, this time using an n-type impurity. Finally, an oxide layer is grown over the whole slice.

The photo-resist and etching techniques are used again to enable a metallic film to be evaporated and alloyed to form the emitter and base areas for making the connexions. Next, all the transistors on the slice are tested electrically, separated and mounted on their headers. The connexions are then made, each device is encapsulated and the case is tested for leaks.

The technology of each of these phases of manufacture is discussed more fully in each of the following paragraphs.

#### SILICON PREPARATION

An ingot of single-crystal silicon is doped with an n-type impurity to give a resistivity of about 1 ohm-cm, i.e. an element is added to the silicon which can donate, to the crystal lattice, electrons that can then subsequently take part in conduction processes; in this type of transistor the element is phosphorus. This doped ingot is sliced with diamond-loaded saws to produce wafers about 2 cm diameter and 0.3 mm thick. Both faces of the slice are lapped with alumina and fine diamond paste to produce flat highly-polished surfaces. One surface is selected from which to work and an electrolytic etching process<sup>2</sup> is used to remove the work-damage produced during cutting and polishing. During the etch about  $35\ \mu\text{m}$  of silicon is removed from this face and the surface is then flat to within  $1\ \mu\text{m}$ , resulting in a final slice thickness of 0.1 mm.

#### OXIDATION

The slices thus produced are now subjected to an overall oxidation by heating at  $1,000^\circ\text{C}$  in steam at atmospheric pressure for about one hour. On removal, the slices are a uniform deep blue in colour, similar in appearance to a "bloomed" camera lens, due to the thin film of surface oxide.

There are alternative methods of growing this oxide, e.g. the slices can be heated in pure oxygen or in steam under high pressure. The relative merits of any particular method are determined by such considerations as the uniformity of the oxide (i.e. the absence of pin-holes), the amount of free water molecules and other impurities entrapped in the film, and the relative ease and the time taken to produce a film of the required thickness.

During later stages in the fabrication of the device, the slices are returned to the oxidation furnace for further films of oxide to be grown. These later oxides contain more or less of the added p-type and n-type impurities, resulting in the growth of borosilicate or phosphate-silicate glasses. Even with the most heavily doped glasses, however, measured leakage currents through these layers are many orders of magnitude smaller than the currents normally carried by the final device.

#### MASKING AND ETCHING

The first process on the oxidized-silicon slice is to define the positions of the final transistors, since an array of at least 300 similar devices can be fabricated at one time on one slice. Over the whole of the top side of the wafer is placed a uniform layer of a varnish-like substance referred to as a photo-resist. This resist becomes hardened when exposed to u.v. radiation. If

now a photographic mask defining the transistor shape (see Fig. 3(a)) is interposed in the u.v. beam, the unex-

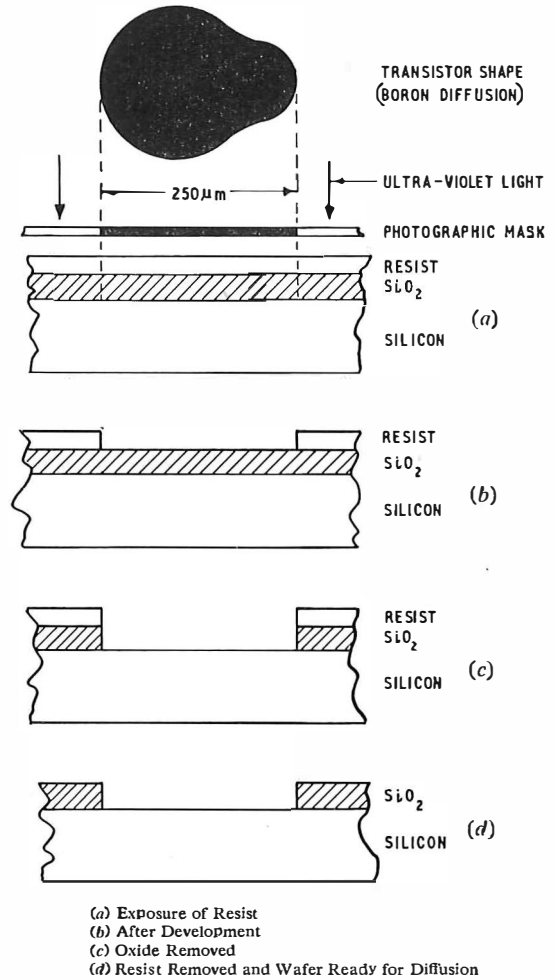

FIG. 3—PHOTO-RESIST PROCESS SHOWING OXIDE-WINDOW FORMATION

posed resist can later be dissolved away in an organic solvent (Fig. 3(b)). The remaining resist is dried and further hardened by baking at  $200^\circ\text{C}$ , and the wafer is ready for etching.

The etch, containing ammonium fluoride and hydrofluoric acid, removes the silicon dioxide in the windows in the resist (Fig. 3(c)) and, finally, the resist itself is removed by boiling in an oxidizing agent (Fig. 3(d)). The wafer is now ready for the first diffusion.

The photo-resist process is essentially similar for each stage of the device fabrication, the only difference being in the photographic masks. Four separate masks are required to complete the set: one to define the collector area (shown in Fig. 4), one for the emitter diffusion, one to cut the emitter and base contact areas, and one to define the evaporated contact areas. The masks are often made on a "step-and-repeat" camera. Successive exposures of a single pattern are made on a high-resolution photographic plate, the plate being moved laterally with respect to the camera between each exposure. A high degree of accuracy in the positioning of each image on the plate is necessary since each mask has to be in exact alignment with the next one of the set (Fig. 5(a)-(d)). A special jig is used to obtain this alignment.

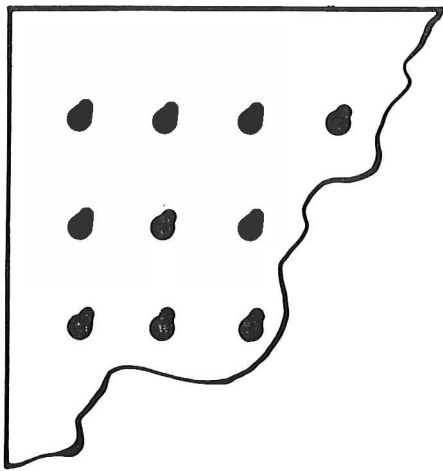
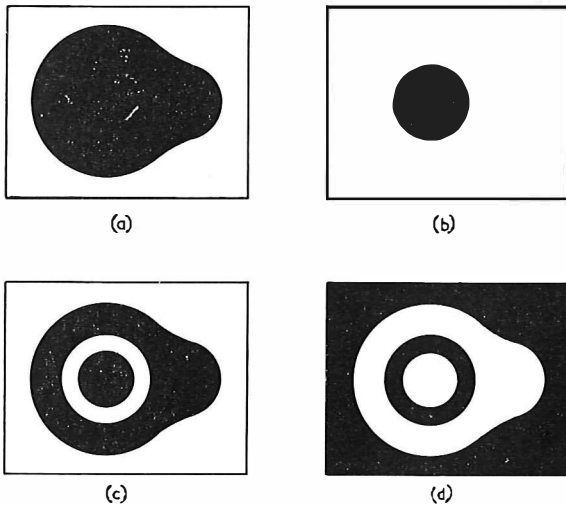

FIG. 4.—SECTION OF TYPICAL PHOTOGRAPHIC MASK SHOWING ARRAY OF TRANSISTOR PATTERNS (MAGNIFICATION 20×)



(a) Collector Diffusion Area  
(b) Emitter Diffusion Area  
(c) Emitter and Base Contact Areas  
(d) Aluminium Evaporated Emitter and Base Contact Areas

FIG. 5.—ENLARGED VIEWS OF SET OF MASK PATTERNS FOR ONE TRANSISTOR (MAGNIFICATION 100×)

#### DIFFUSION

The first diffusion, that of boron, a p-type impurity, i.e. an element which accepts electrons from the crystal lattice leaving a deficit so that conduction is by holes, overcompensates the n-type impurity already present to give a net p-type region. This conversion only occurs through the holes in the oxide and no conversion takes place except at these spots, since the oxide acts as a mask to the diffusant. The resulting impurity distribution away from the window is shown in Fig. 6 and where the concentrations of the two types of impurity are equal (but opposite in sign) a p-n junction is formed. This first diffusion results in the formation of the collector-base junction.

There are many ways in which the diffusion process can be accomplished but only the process of continuous gaseous diffusion in a heated furnace tube is described. A tube of silica, about 2 in. in diameter and several feet long, is heated externally so that two distinct regions at different temperatures are formed along the tube. The slices of silicon are placed in the higher temperature

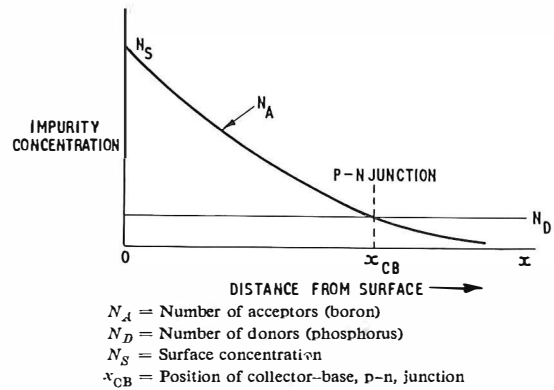

FIG. 6.—IMPURITY DISTRIBUTION AFTER FIRST DIFFUSION

(say 1,100–1,200°C) region and at the lower temperature zone is placed the source of diffusant, an oxide or other compound of the n-type or p-type impurity required. Through the tube, from the source zone to the diffusing zone, is passed an inert carrier gas such as nitrogen. The required impurity is continually deposited in the small windows in the oxide and diffuses into the silicon for some hours. As shown in Fig. 2, the p-n junctions produced after this furnacing are protected by the initial oxide layer and lie about 3  $\mu\text{m}$  below the initial surface.

The silicon slice is removed from the boron diffusion furnace and a further oxide is grown over the whole slice. This oxide is grown at a lower temperature and is about 0.5  $\mu\text{m}$  thick in the collector windows.

The second mask is now positioned over the centre of the original pattern and, using the photo-resist technique, a new set of holes defining the emitter regions is etched through this new oxide. The silicon wafer is returned to a second diffusion furnace, similar in design to the first, but the impurity is phosphorus. The regions immediately beneath these windows are reconverted to n-type, and again the p-n junctions so formed reach the silicon surface just outside the emitter windows and under the oxide layer, the depth of the junction below the surface being about 2.5  $\mu\text{m}$ . Typical impurity profiles and the positions of the emitter and collector junctions are shown in Fig. 7.

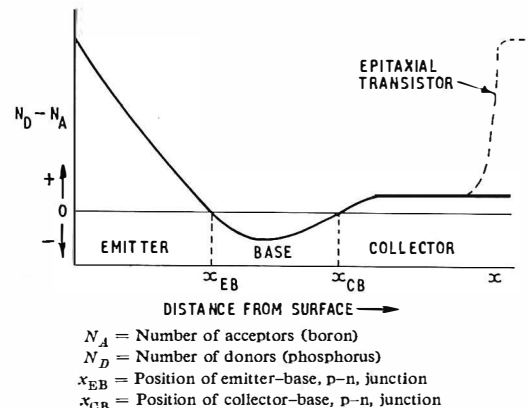

FIG. 7.—NETT IMPURITY CONCENTRATIONS SHOWING POSITIONS OF EMITTER AND COLLECTOR P-N JUNCTIONS

Finally, the whole slice is returned to the oxidation furnace and a further oxide layer is grown over the whole slice.

#### ELECTRODE EVAPORATION AND ALLOYING

The third mask is now used to mark the positions of

small holes in the centres of the emitter diffused areas for the emitter connexion, and of concentric rings outside the emitters to form the base connexions. The oxide is then etched away from these regions and from the back of the slice. Over the whole front surface of the wafer, heated to about 300°C, a film of aluminium is evaporated. It is essential that this evaporation be performed under conditions of high vacuum and extreme cleanliness. Typically, vacuum systems constructed entirely of stainless steel and capable of being outgassed at 400°C and of reaching pressures of  $10^{-7}$  mm of mercury are used.

Using the fourth mask, the contact areas are protected by photo-resist and the aluminium elsewhere is removed by etching with sodium hydroxide. The wafers are returned to the vacuum system and are heated to just above the eutectic temperature of the aluminium-silicon alloy, i.e. 577°C. A film of gold is then evaporated on, and alloyed into, the back face at a temperature just above 370°C, i.e. the eutectic temperature of the gold-silicon alloy, to provide a large-area connexion to the collector region. These alloying procedures only provide low-resistance connexions to the appropriate transistor regions and in no way affect the p-n junctions produced by the diffusion processes.

#### SCRIBING AND LEAD-WIRE BONDING

Up to this point all transistors on a slice have been treated alike and it is at this stage that the first electrical measurements can be made. The slice is mounted under a microscope and fine probe wires are brought down on to each transistor in turn and the current gain and breakdown voltages are recorded. A mark is made on the slice against any faulty devices, so that these units can be rejected at the next stage.

The next operation is to separate the array of transistors into individual units, by scribing across the slice, "chocolate-block" fashion, and breaking the slice into squares of about  $1 \times 1$  mm.

The gold-plated transistor header, i.e. the bottom part of the transistor can, with the lead-through wires for the base and emitter, is heated to about 400°C and the small square of silicon is alloyed in a convenient position between the two lead-through wires.

The connexions between the emitter and base electrodes and the lead-through wires are now made with fine wire about 25  $\mu$ m in diameter. There are two methods of making these bonds, both of which are referred to as thermo-compression bonds, i.e. bonds formed under a combination of heat and pressure such that local deformation and melting or alloying takes place, but the two methods differ in the final shape of the lead wire in contact with the electrodes. The more common bond is referred to as a chisel bond. In this bond the wire is laid across the base or emitter region and a small blunt-ended chisel deforms the wire into intimate contact with the aluminium-silicon regions. From the mechanical strength point of view, however, the second method, referred to as a ball or nail-head bond, is preferred. To make this bond the wire is passed through a glass or tungsten-carbide capillary tube, the end of the wire is melted to form a small ball, the ball-ended wire is lowered into contact with the aluminium electrode and is then deformed under pressure so that the resulting connexion to the electrode area has the appearance of a nail head.

Of the two most suitable metals for the lead wires, namely gold and aluminium, only gold at the present time is suitable for nail-head bonding. Ideally, ball-bonded aluminium wire would be used, but due to the difficulty in producing ball-ended aluminium wire (since aluminium is too easily oxidized in the conventional ball-forming process) gold is at present used. Further work at the Post Office Research Station is in hand to attempt to overcome this difficulty.

Gold may be unsatisfactory because of the formation of a gold-aluminium compound, often referred to as the "purple-plague" due to its colour, which, although metallic in nature, is brittle and could cause transistor failure due to lead breakage. An additional compound of gold-aluminium-silicon can also be formed which is thought to be non-metallic in the pure state and equally brittle and, again, could cause lead failure. A possible additional argument against the use of gold may be the relative ease with which this element can diffuse away from the bond area into the base region between the emitter and the collector, causing small changes in the electrical characteristics of the device during the 20 years operational life required. The use of gold at the collector connexion to the header can, however, be tolerated due to the relatively large distance that this electrode is from the base region.

#### ENCAPSULATION AND LEAK TESTING

Of the many forms of transistor encapsulation currently used, a description is given only of the all-metal "top-hat" form of can. Most commercial units of this type use an electrically welded mild-steel or nickel can, filled with dry nitrogen. However, whether the can should be filled with some dry inert gas or evacuated is as yet unresolved. The evacuated can is certainly more expensive and some small advantage due to improved thermal conduction through any gas in the can away from the active transistor may prove to be important in future high-frequency transistors due to the very small lead wires likely to be used. However, for transistors that are to be used in satellites, especially those that may pass through radiation belts in the upper atmosphere, the choice would seem to be for evacuated units. It has been reported, for instance, that for gas-filled units the gas becomes ionized by radiation and the ions are then attracted to the semiconductor surface, especially if the active regions have an electrical bias applied, and degrade the electrical characteristics. Admittedly these results were on silicon units which did not have oxide passivation of the surface, but additional work has to be done to prove or disprove this effect with planar devices.

However, it is evident that a leak-free container is required. Work at the Post Office Research Station<sup>3</sup> has shown that a cold-welded copper can is ultimately preferable for both gas-filled and vacuum encapsulations due to the smaller quantity of metal and gas given off into the can during the sealing operation.

#### *Leak Detection*

Two methods of leak detection are now in common use, the measurement of helium leaking out of a sealed encapsulation by means of a mass spectrometer, and the measurement of the gamma ( $\gamma$ ) radiation from krypton 85 which has been forced into the can under high pressure.

Leak rates as low as  $10^{-12}$  Atm per cc per sec can be detected.

ted by both methods. Since, however, the half-life of the  $\gamma$  radiation is about 10 years, any of the gas that did leak in might degrade the electrical performance unnecessarily. For this reason, as well as for the greater ease with which helium is handled, the first method is to be preferred.

#### EPITAXIAL PLANAR STRUCTURE

One particular aspect of the planar-transistor geometry which is something of an embarrassment to the circuit designer, especially in pulse applications, can be appreciated by referring to Fig. 2 again. The slice of silicon between the collector p-n junction immediately below the emitter and the collector connexion to the can introduces an unwanted series resistance into the collector circuit. The slice could be made thinner, but the resulting structure would be too difficult to handle as the collector junction is only about  $2.5 \mu\text{m}$  below the surface. An alternative solution is what is termed an epitaxial planar structure. Epitaxy is the term used when one crystal structure is allowed to grow upon another with the same crystal orientation. The material from which such transistors are made consists of a substrate of heavily doped silicon (i.e. it has very low resistivity) upon which is grown, thermally, a thin layer of higher-resistivity silicon; into this layer the planar structure is fabricated (see Fig. 7). The substrate serves two purposes: (a) a mechanical support for the device, and (b) a low-resistance connexion to the can or collector lead.

However, an epitaxial transistor need not necessarily be a planar device. Any transistor structure fabricated from one side of a slice can use this technique; in fact, epitaxial "mesa" transistors, both germanium and silicon, are manufactured in this way.

Strictly, assuming that a low  $V_{CE(SAT)}$  is not required, epitaxial types may have doubtful reliability. Invariably such substrate material contains a higher proportion of crystal defects than that normally used for the simpler planar type, and it has yet to be proved that these do not effect the life of the device.

#### CONCLUSIONS

The silicon planar transistor is showing great promise as a potentially highly reliable device, but only extensive life tests on such units can verify this. Meanwhile, many aspects of the technology of planar devices are being studied at the Post Office Research Station with a view to producing a range of devices suitable for future cable and satellite systems.

#### References

- <sup>1</sup>HENDERSON, J. C. Assessment of Transistor Life. *P.O.E.E.J.*, Vol. 53, p. 236, Jan. 1961.  
<sup>2</sup>BAKER, D. and TILLMAN, J. R. Preparation of Very Flat Surfaces of Silicon by Electropolishing. *Solid State Electronics*, Vol. 6, No. 6, Nov.-Dec. 1963.  
<sup>3</sup>BAKER, D. Inleakage and Outgassing of Transistors Encapsulated by Cold Welding and by Electric Welding. *Le Vide*, No. 106 p. 363, July-Aug. 1963.

## Book Reviews

"Information Theory and its Engineering Application."  
D. A. Bell, M.A., Ph.D., M.I.E.E. Sir Isaac Pitman & Sons, Ltd. viii + 196. 43 ill. 25s.

This is a new edition and the extra 58 pages are devoted mainly to an expansion of the chapter on "Coding," a new chapter on "Decoding" and one on "Electronic Computers and Data-processing."

Information theory treats the process of sending a message as the selection of one of a given defined set of patterns and reception is identification of that pattern out of the same set. The theory deals mathematically with the properties of sets of possible messages and the condition for successful identification. The ordinary person's feeling that information is some "stuff" that can be transmitted is thus rather remote from these abstractions and so it is not surprising that the subject is extremely difficult to grapple with.

The book claims to deal without requiring much mathematical background, but it is unlikely that an ordinary graduate engineer new to the subject would be able to proceed far through the book without having to follow up many of the references given in footnotes. If conscientious, his resulting mathematical knowledge would be considerable before reaching the end. The book is based on a course of lectures and so the absence of the lecturer is a severe handicap.

The title would encourage the belief that many engineering applications exist, but those quoted are covered in a single chapter which has increased since 1953 (the First Edition) by merely the addition of "Delta-modulation" and some expansion of "Television Frequency Interlace." It should not, however, be inferred that the subject is useless; although few, if any, technological advances can be directly attributed to the theory, it does at least instil discipline, serve to define the bounds of what is logically possible and act as a fertilizer to ideas.

The book can be recommended to the inquirer who is willing to work hard for his instruction and has access to the footnote references.

D.L.R.

"Russian-English Chemical and Polytechnical Dictionary (2nd Edition)." L. I. Callaham. John Wiley and Sons. xxxi + 892 pp. 147s.

"When I was compiling the first edition of this dictionary," writes the author in her preface, "there was nothing I wanted so much as to emulate Patterson's German-English Dictionary for Chemists." Like Patterson, Callaham gives terms from many branches of science besides chemistry. She also includes many common non-technical words occurring in scientific literature. This saves reference to a general dictionary, and is also extremely useful because the more literal, "scientific" meanings of words are given in isolation and do not, as in a general dictionary, have to be disentangled from the more complex, literary meanings.

The present (1962) edition of this dictionary is generally recognized as a useful work of reference and is held by many public libraries.

F.W.J.H.

"E.E.A. Guide to the Servicing and Testing of Electronic Equipment containing Semiconductor Devices." Electronic Engineering Association. 10 pp. 3s.

The booklet is a practical guide to the servicing of modern equipment containing semiconductor devices, and particularly equipment with printed-wiring boards. This type of equipment needs a careful, systematic and delicate approach, and a code of practice is described for testing the equipment and changing components. Emphasis is placed on careful soldering and the use of heat shunts to avoid damage to semiconductor devices.

The booklet is written in a direct and readable style; it wastes no words and can be well recommended.

H.G.B.

# Inland Radio Planning and Provision Branch Exhibitions at 2-12 Gresham Street, London, E.C.2

U.D.C. 66.06:621.396:654.16

CERTAIN Branches of the Post Office Engineering Department have in the last few years held small exhibitions of current developments and practices in the entrance hall of 2-12 Gresham Street, London, E.C.2, the headquarters of the Department.<sup>1</sup> During June and July 1963, the Inland Radio Planning and Provision Branch (WI) gave two such exhibitions, each of which lasted for 2 weeks. The theme of the first exhibition was "Microwave Radio Links" and of the second "Broadcasting, Interference and Mobile Radio Services." These exhibitions and, consequently, this report provide a summary of the current work of WI Branch.

## Microwave Radio Links

The dominant item of the microwave radio-link exhibition was a small horn paraboloid aerial rising 14 ft above the floor level of the hall (see Fig. 1). This is the smaller of two types of horn-paraboloid aerial in general use on microwave links, the larger one

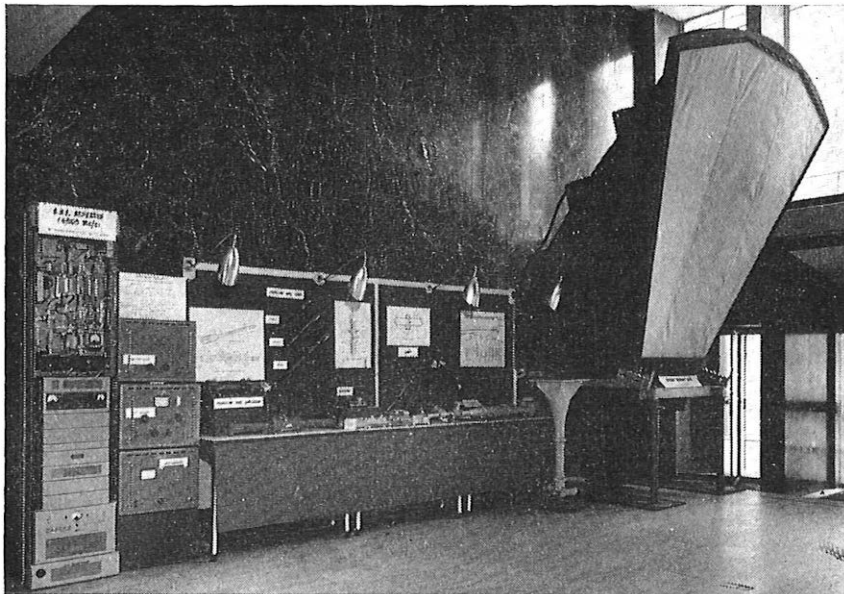

FIG. 1—MICROWAVE-EQUIPMENT STAND

having approximately the same proportions but an overall height of 26 ft. The main advantage of these aerials is their considerable channel-handling capacity, as they are efficient over a frequency range of 3,500–11,000 Mc/s and can simultaneously handle signals in both the vertical and horizontal planes of polarization.

All the items of equipment normally used in separating the broadband signals and feeding them from the aerial to the s.h.f. repeaters were displayed as individual items. This method of presentation allowed visitors to examine and handle the items. These included:

(a) A transition unit, which transforms signals from  $H_{10}$  modes in the 1 ft square aperture of the base of the horn paraboloid to  $H_{11}$  modes in the 2.812 in. diameter circular waveguide. It was manufactured by an electro-forming process.

(b) A length of flexible circular waveguide.

(c) An ellipticity compensator. This is a device for improving the cross-polarization discrimination of a circular-waveguide feeder-system, by introducing slight but controlled deformation of a section of circular waveguide.

(d) A 6,000 Mc/s transducer unit which transforms signals from the  $H_{11}$  modes in circular waveguide to  $H_{10}$  modes in rectangular waveguide, and is used for separating the horizontally-polarized and vertically-polarized signals received at the aerial for transmission in independent rectangular waveguides. Conversely, the system is used for combining signals fed to a common aerial.

(e) A length of flexible rectangular waveguide.

(f) An aerial circulator. This device is used in conjunction with waveguide filters to separate or combine several broadband microwave channels for common-aerial working.

(g) Ferrite isolators. These are non-reciprocal devices used to minimize multiple reflections or inter-action between stages and components.

(h) A rack containing a s.h.f. repeater for operation within the band 5,925–6,425 Mc/s.

A block schematic diagram placed conveniently near the horn paraboloid aerial indicated the way in which the broadband signal is separated into channels, each of which can handle 960 telephone conversations or one television signal. Coloured ribbons led from several of the principal items to the appropriate point on the diagram to indicate their relative position and function.

A white-noise test set, which is used to assess the intermodulation channel crosstalk and noise on broadband multi-channel telephone systems, was placed by the s.h.f. repeater. The test set consisted of three separate units: a noise generator, a noise receiver and a band-stop filter.

Other items displayed on the main stand were a phase-shifter for diversity reception, and various types of u.h.f. and s.h.f. valves. The valves included a disk-seal triode, a klystron, a travelling-wave amplifier and three samples of travelling-wave tubes for use at frequencies of 2,000, 4,000 and 6,000 Mc/s. Sectional diagrams of each type of valve were arranged near each of the valves.



On the left-hand side of the hall, the existing links and links under consideration for the microwave trunk network were prominently shown on a large coloured map of the United Kingdom. A table of statistics was placed at the side of the map; from this table, reproduced below, the continuing expansion of the network could be seen.

Microwave Radio-Link Statistics

| Items   | Totals      |              |              |
|---|-------------|--------------|--------------|
|   | 1 June 1963 | 1 June 1966* | 1 June 1970* |
| Number of radio-relay stations .. .. .                                      | 77          | 109          | 120          |
| Radio-link route mileage .. .. .  | 1,729       | 2,233        | 2,500        |
| Working uni-directional broadband-channel mileage for television .. .. .    | 3,230       | 6,600        | 15,000       |
| Working uni-directional broadband-channel mileage for telephony .. .. .     | 774         | 4,915        | 9,000        |
| Working uni-directional broadband-channel mileage for wideband data .. .. . | —           | 2,000        | 2,000        |
| Working uni-directional broadband-channel mileage for all purposes .. .. .  | 4,004       | 13,515       | 26,000       |
| Telephone-circuit capacity (circuit miles) .. .. .                          | 200,000     | 2,500,000    | 6,000,000    |

\* Estimated.

The two other large items of interest on the left-hand side of the hall were an outside-broadcast portable microwave unit and a 4 ft-high scale model of the London Post Office Radio Tower.<sup>2</sup> Coloured ribbons were also used to indicate the principal features of the model, the labels being laid out on the base. A panoramic photograph of London's skyline, shown in two long narrow strips, was mounted behind the model. The scene was taken from the present lattice tower on the roof of Museum telephone exchange.

The outside-broadcast unit was the type used to transmit either a 405-line or 625-line television signal and comprised the transmit terminal only. This consisted of a control unit and power unit, multi-way cable drum, the aerial, and transmitter head unit. The transmitter head unit accepts a video signal and transmits a frequency-modulated signal at approximately 7,000 Mc/s. The transmitter head unit and aerial were assembled together on a tripod-mounted panning head. The aerial was a 4 ft diameter paraboloid of metallized glass fibre.

The exhibition was completed with a 10 min film, shown continuously, which portrayed the work involved in planning, manufacturing and installing complete aerial systems on microwave links.

*Broadcasting, Interference and Mobile Radio Services*

The second exhibition, held a week after the first,

showed an entirely different side of WI Branch's work. On this occasion the right-hand side of the entrance hall was occupied by a series of angled stands giving three large recesses (Fig. 2), each of which was used to represent a different aspect of the Branch's activities: public radiophone services, private mobile radio services and television broadcasting.

The public-radiophone-services display gave details of the operating system, methods of calling, and the frequencies used for both existing and proposed land and maritime services. Maps of the service areas for the two inland systems, that of South Lancashire<sup>3</sup> and the proposed Greater London scheme, stood out in relief against the background, and showed the location of the transmitting stations and the principal towns inside or on the borders of the service area. A colourful representation of the links in the setting-up of a call from a subscriber to a mobile subscriber was shown, using photographs of a business subscriber, an operator at a switchboard, a radio station and a subscriber using mobile radiophone equipment installed in a car.

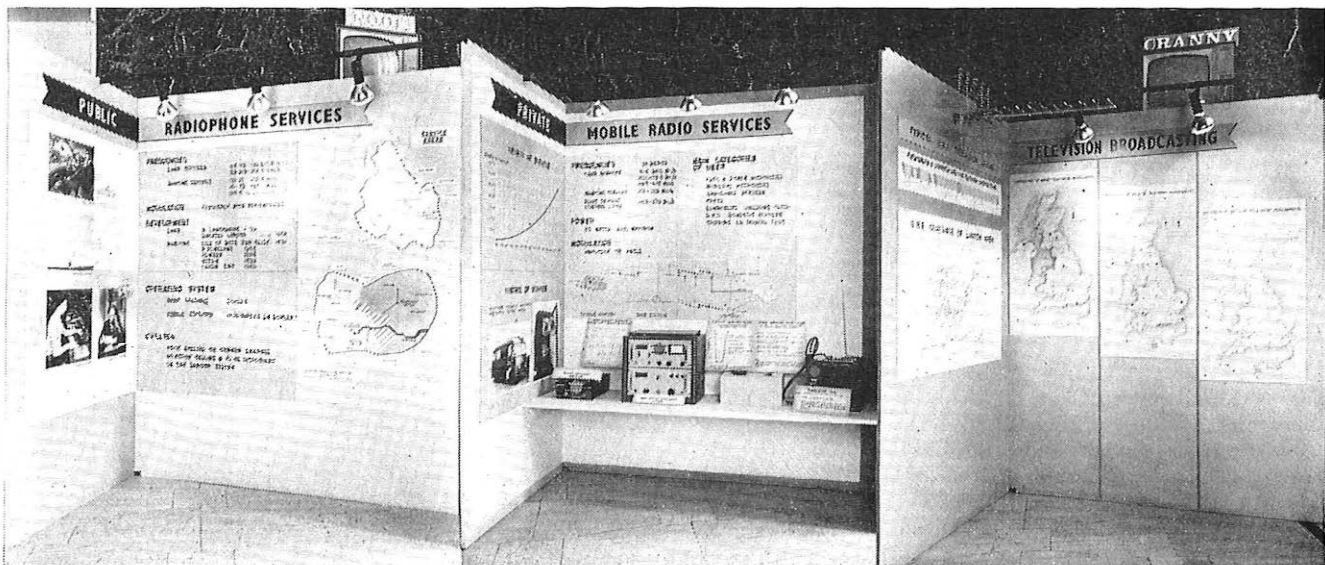

FIG. 2—MOBILE RADIO AND BROADCASTING STAND

In the second recess technical details of the private mobile radio (p.m.r.) services, some apparatus used on Post Office domestic p.m.r. services and a method used to control p.m.r. services were shown. The technical details displayed included frequencies, maximum permissible effective radiated power and types of modulation. The apparatus shown included a base-station equipment (Equipment, Radio, No. 5A), a mobile equipment (Equipment, Radio, No. 6A), and the new hand portable equipment (Transceiver No. 1A) that has been introduced in conjunction with the External Plant and Protection (Cn) Branch for use when installing long lengths of underground cable. It may also be used to replace obsolescent equipment on radio-interference duties. Other small items shown were a miniature crystal oven, with a temperature stability of  $\pm 2^\circ\text{C}$  over a permissible change in ambient temperature from  $-20^\circ\text{C}$  to  $+65^\circ\text{C}$ , and a band-pass filter, both of which are used in typical p.m.r. equipments. The growth of the p.m.r. services was shown by a graph, the curve being approximately exponential for the period 1949–1963. The total number of stations has now risen to 35,000, i.e. nearly 0.5 per cent of all road vehicles are now estimated to have a mobile radio station installed. Photographs of a vehicle<sup>4</sup> of the type used to check and control the use of the p.m.r. services were shown.

WI Branch takes a large part in the planning of the frequency assignments for both sound and television broadcasting. From the display in the third recess could be gauged how far television broadcasting had spread and how the coverage is being improved in the United Kingdom in Band I, exclusively used by the British Broadcasting Corporation, and in Band III—so far exclusively used by the Independent Television Authority. This was shown by two large maps, one for each band, on which all main transmitting stations, with their approximate service areas, and all working or proposed low-powered relay transmitter (satellite) stations were marked. In Band I, for example, there are 30 main stations, five working satellite stations and just over 200 proposed satellite stations. A third map of the United Kingdom showed how the country would eventually be served by the u.h.f. stations in Bands IV and V, with each station having four frequency allocations. More detailed information on the service area of the first u.h.f. transmitting station due to open at Crystal Palace in 1964 was shown on a large-scale map of the London area. A narrow coloured strip showed the frequency spectrum covered by the television broadcasting bands, and the channel numbering scheme.

A typical u.h.f. aerial for television reception, a Yagi-type array of 13 elements with a bandwidth sufficient to cover the four frequency allocations of one area, was also displayed and proved of interest to many visitors.

Two commercially-produced television receivers were placed at the back of the recesses at a height of approximately 8 ft, and these were used in conjunction with the working model of the television-detector system on the other side of the hall. The television-detector equipment was housed in a solidly-built cabin (Fig. 3) designed to have a similar layout to that of an actual detector vehicle,<sup>5</sup> but which enabled spectators to step inside quite easily and operate the equipment.

Basically the detector consists of a directional aerial and a panoramic receiver which are used to detect local-



FIG. 3—WORKING MODEL OF TELEVISION DETECTOR

oscillator radiation from the receivers. The panoramic receiver has a maximum frequency sweep of 8 Mc/s, which is reducible to zero.

For the purposes of the demonstration the sweep width was set at 2 Mc/s. Two signals were displayed on the screen of the panoramic receiver from each of the two similar television receivers placed approximately 12 ft apart on the opposite side of the hall and appropriately titled “Nook” and “Cranny.” Both receivers were tuned to channel 11, a channel not used in the London area for television broadcasting. As the receivers were not connected to an aerial system, the oscillator radiation detected was, therefore, wholly from the chassis of the television receivers. Although the local oscillators of these two receivers were nominally on the same frequency, this setting is not critical (most receivers are provided with a fine tuner) and the oscillator frequencies were approximately 200 kc/s apart, giving a horizontal displacement of about  $\frac{1}{2}$  in. between the two vertical signals or “blips” on the screen of the panoramic receiver.

Visitors were able to rotate the aerial until either of the two signals on the screen was a maximum. The aerial was then “looking” at the receiver, and the accuracy could be checked by looking through the periscope. Judgment of the signal maximum was, however, made very difficult by the people moving about in the hall. This was a nuisance from a demonstration point of view but, as it was pointed out, this feature is a help in normal working, because the

operator can see a change in the signal level when a householder moves to answer the door, thereby giving further confirmation of detection.

The second working model of the exhibition was provided by the power unit for the television-detector car. The unit was operated under normal load condition, supplying the panoramic receiver of the television detector. The d.c. input voltage could be varied between 12 and 16 volts to simulate the normal changes experienced with a vehicle battery. A change of 1 volt in the 300-volt output would have been indicated by a full-scale deflexion on a bridge-connected meter. A minimum stability of 1 part in 1,000 was claimed for this 300-volt output, and this was confirmed by the very slight movement on the meter when the input voltage was varied between its limits.

A large photograph of a television-detector car was displayed above the power unit, and two large coloured sectional diagrams of the working parts of the periscope and the rotatable coaxial coupling from the aerial were mounted on a panel at the side of the cabin.

The stand at the side of the television detector was devoted to radio and television interference suppression. A large arrow formation contained a representative range of radio and television interference suppressors developed by, or in conjunction with, the Branch. They ranged from a large 100-ampere, copper-strip, spiral inductor for medium-wave frequencies to a 1-ampere inductor only 1 in. in length for use at television frequencies, and included many different types of filters. Various types of ignition interference suppressors were shown separately and included samples of resistance cable that has been used increasingly by car manufacturers since 1954.

The way in which the suppressors are normally fitted

to typical domestic appliances could be seen from a show case beneath the suppressors, where an electric drill, a toy car, a section of a toy-car racing track and a battery dry-shaver were arranged so that the suppressors fitted to them were clearly visible. A transistor-type portable tracing receiver (Receiver, Radio, No. 27A), used by radio-interference-investigation staff in the field, was fitted beside the domestic appliances.

A third demonstration model showed a tunable filter (Filter, Suppression, No. 48/2A) in use. This type of filter has a very narrow stop-band, is tunable over the frequency range 45–100 Mc/s, and has a maximum insertion loss greater than 30 db. When fitted into the aerial feeder of a v.h.f. or television receiver it can eliminate c.w.-type interference. For the demonstration a signal from a pattern generator was fed to the television receiver via a combining unit and the filter. The receiver was tuned to channel 4 (vision frequency 61.75 Mc/s). A c.w. signal was injected into the combining unit at a frequency of 61 Mc/s. As this frequency was within the pass-band of the receiver, severe interference resulted, but it could be eliminated from the picture by carefully tuning the filter.

D.B.C.

#### References

<sup>1</sup>Exhibition of Subscribers' Apparatus and Associated Equipment at 2–12 Gresham Street, London, E.C.2. *P.O.E.E.J.*, Vol. 53, p. 265, Jan. 1961.

<sup>2</sup>KNEE, H., and BALCOMBE, F. G. Museum Radio Tower. *P.O.E.E.J.*, Vol. 55, p. 73, July 1962.

<sup>3</sup>ARMAN, L. T., and MELLER, V. C. The South Lancashire Radiophone Service. *P.O.E.E.J.*, Vol. 52, p. 253, Jan. 1960.

<sup>4</sup>ARMAN, L. T., and PECK, E. J. M. Monitoring Station for Mobile Radio Services. *P.O.E.E.J.*, Vol. 55, p. 228, Jan. 1963.

<sup>5</sup>BURLING, K. G., and FENNING, J. C. A New Detection System for Television and V.H.F. Radio Receivers. *P.O.E.E.J.*, Vol. 55, p. 219, Jan. 1963.

## Standardization and Control of Colour for the 700-Type Telephone

JOAN L. CRAFT†

U.D.C. 620.11:535.65:678.01

**With the greater availability of plastic materials, the range of colours and coloured items used by the Post Office, particularly with the new 700-type telephone, has increased. In consequence, techniques for the inspection of colour matching and metamorphism have had to be developed. A description is given of these methods and of apparatus which can be used to measure colour.**

#### INTRODUCTION

**B**RIGHT, gay colours are much in evidence nowadays in painting, architecture, interior decoration and design. This is probably due to the growing realization of the psychological effect of colour and to the availability of new materials. There has been a great increase, since the war, in the use of plastics, especially the thermoplastics, many of which can be coloured in an almost infinite variety of shades.

It is not surprising, therefore, that when the Post Office 700-type telephone<sup>1</sup> was redesigned in 1959 the range of colours was increased.<sup>2</sup> The material chosen for the case and handset was polymethylmethacrylate, a colourless transparent polymer with good resistance to light-aging and capable of being readily coloured by the

moulder in any required shade. A large number of coloured plaques was submitted to the Council for Industrial Design for their final selection and seven coloured telephones were produced, two of them in two tones, making a total of nine different colours. These are known as forest green, aircraft grey-green, elephant grey, light French grey, concord blue, topaz yellow, lacquer red, light ivory and black.

This presented the Test and Inspection Branch of the Post Office Engineering Department with the problem of controlling the colour of thermoplastic coloured parts. Five main manufacturers produce the mouldings, each manufacturer dealing with the complete range of colours. Although the subscriber would probably not object to small variations from the chosen shade, a close match is required since handles, earcaps, mouthpieces and cases may be made in different factories and later assembled into a single instrument. Replace-

<sup>1</sup>SPENCER, H. J. C., and WILSON, F. A. The New, 700-Type Telephone. *P.O.E.E.J.*, Vol. 49, p. 69, July, 1956.

<sup>2</sup>SPENCER, H. J. C., and WILSON, F. A. The New 700-Type Table Telephone—Telephone No. 706. *P.O.E.E.J.*, Vol. 52, p. 1, Apr. 1959.

†Test and Inspection Branch, E.-in-C.'s Office.

ment parts are also required when a telephone is damaged in service and these parts must match the remainder of the instrument.

#### INSPECTION PROCEDURE

As the range of colours did not conform to any of the British Standard shades, for which shade cards are readily available, colour standards had to be issued to the manufacturers before production began. These original colour standards were in the form of plaques, but standards in this form were found to be unsuitable for judging production as it was difficult to make a reliable assessment of colour when comparing the curved surface of a telephone with a flat plaque. Working standards were therefore introduced of similar shape to the article being examined, e.g. a case is compared with a standard case and a handset with standard handset.

Samples of the bulk production of the moulded parts are inspected at the contractor's works. Before undertaking this work, inspectors are given a detailed examination for the less obvious types of defective colour vision, using the Ishihara charts, and for their ability to arrange in order a series of plaques with small differences of shade. It has been found that an experienced inspecting officer selected by this means has little difficulty in detecting small variations of colour.

Inspection of bulk production is done on a purely visual basis. Few of the firms have any instrumental means of checking colour. This is not surprising as colour-measuring instruments are expensive and have certain disadvantages in use. Visual inspection on the other hand has much to recommend it provided that its limitations are recognized and that care is taken to make the inspection under suitable conditions. With a trained operator, working under an illumination of not less than 75 lumens per square foot from a suitable light source, slight differences of shade are readily recognized. Prolonged staring at a coloured object results in loss of sensitivity, so a quick decision is necessary. If there is doubt, a second inspection is made after resting the eye for a minute or so. The greatest advantage of visual inspection is that no special apparatus is required and that large numbers of samples can be inspected in the factory. The ability to give a rapid, on the spot, decision is particularly important in the inspection of injection-moulded items where a delay of only a few days in calling attention to a fault could result in the production of many thousands of unacceptable parts. A high density of sampling is not necessary since for any one blend of moulding powder there should be little or no variation in colour of the moulding. A sample from the beginning and end of each run is normally sufficient.

It is very seldom that an exact match to the standard is achieved because of difficulties in the manufacturing process. For each of the colours in use at least four different pigments need to be blended with the transparent polymer to produce the required shade. Some of the pigments are used in small amounts, and slight inaccuracies in weighing out and in the technique of mixing will cause a marked change in the shade. The basic pigments themselves also vary slightly in colour from batch to batch. An additional complication is that a polymer-pigment blend which will produce the correct shade on one moulding machine will not necessarily produce the same shade on another machine that runs at different pressures or temperatures. The amounts of the pigments have to be adjusted to allow for this.

Because of these difficulties it is necessary to permit slight variations in shade from the standard although clearly such variations should be kept within limits. It is at this point that visual methods become inadequate, and even experienced colour inspectors will not agree on tolerances. This has been a frequent cause of disagreement in the past and it was therefore arranged that all cases of doubtful colour should be referred to a primary standard kept at the London Materials Section of the Tests and Inspection Branch. Samples thus submitted have their colour measured on a tristimulus colorimeter and the readings are converted into C.I.E. units (Commission Internationale de l'Éclairage). This is a numerical description of a colour as it appears to a "standard observer" and is given in terms of two chromaticity co-ordinates and a luminance factor. Given these figures it is possible to give a numerical value for a deviation from the standard.

#### MEASUREMENT OF COLOUR

Many instruments are available for the measurement of colour in terms of C.I.E. units but there are three main types.

##### *Spectrophotometers*

The spectrophotometer type of instrument measures the reflectance of a surface to lights of different wavelength and the results are usually plotted as a spectral reflectance curve, which is typical of the colour in question. A prism or diffraction grating is used to produce a spectrum and by a system of lenses and slits each part of the spectrum, consisting of essentially monochromatic light, is used to measure the reflectance at that particular wavelength. The intensity of the reflected light is compared with that of the incident light with a photocell or thermopile. In the more elaborate instruments both the scanning of the spectrum and the recording of the results is automatic, and a complete plot of the reflectance against wavelength is quickly obtained. It is usual to compare the reflectance with that of a standard surface; a freshly prepared magnesium-oxide surface is commonly used as this shows nearly 100 per cent reflectance over the whole spectrum, or, in common parlance, it is a good white. Spectroradiometers, which measure the energy of the reflected light in absolute units, are also available but such instruments are complicated and are little used except for research; as one authority has remarked, to keep it in calibration day after day is itself almost a continuous research project.

For practical purposes the curves obtained from the spectrophotometer need to be translated into C.I.E. units before the effect of two colours on the human eye can be assessed. It is quite possible that two-coloured objects with different spectral reflectance curves might appear identical to the eye. This is because the eye behaves as though it had three types of receptors, each sensitive to a part of the spectrum. Any colour can thus be simulated visually by mixing light from three regions of the spectrum and the C.I.E. units may be regarded as measures of the responses of the three types of receptors. Unfortunately, each receptor is stimulated to some extent by all parts of the spectrum so that to translate a curve it is necessary to integrate in steps throughout the whole curve. For example, light of wavelength 400 m $\mu$ \* has tri-stimulus values of 0.0143, 0.004, and 0.0679 for the three hypothetical receptors. The

\*m $\mu$ —millimicron or 10<sup>-9</sup> metres.

calculation is therefore tedious and greatly affected by small errors of measurement. The theory of colour vision is still far from being completely understood. For example, the presence of the three types of receptors in the eye has yet to be demonstrated. However, it is well established that the three figures of the C.I.E. system are a complete specification of a colour so far as it affects the eye.

### Visual Colorimeters

There are two main types of visual colorimeter: the additive and the subtractive. In a typical instrument of the latter type the surface is illuminated so that the reflected light is viewed adjacent to a reference surface of magnesium oxide which is similarly illuminated. The colour of the reference field is then adjusted by the inter-position of coloured glass filters until a match is obtained. This type of instrument has the advantage that the human eye is used as the sensing element so that differences to which the eye is not sensitive are disregarded, but it has the disadvantage that the accuracy and repeatability of the results is very dependent on the colour vision, skill and judgment of the particular operator. The results may be easily related to C.I.E. units.

### Photo-electric Tri-stimulus Colorimeters

In photo-electric tri-stimulus colorimeters light is passed through one of three coloured filters to illuminate the sample. The reflected light is collected by a photocell and the response is measured either by a galvanometer or by a bridge. Again, the magnesium-oxide surface is used as the reference standard surface and the C.I.E. co-ordinates and luminance are readily calculated. These instruments have the advantages that they respond to three broad regions of the spectrum in the same way as the eye does (the three filters are selected to satisfy this condition) and also that the measurement is basically electrical and does not

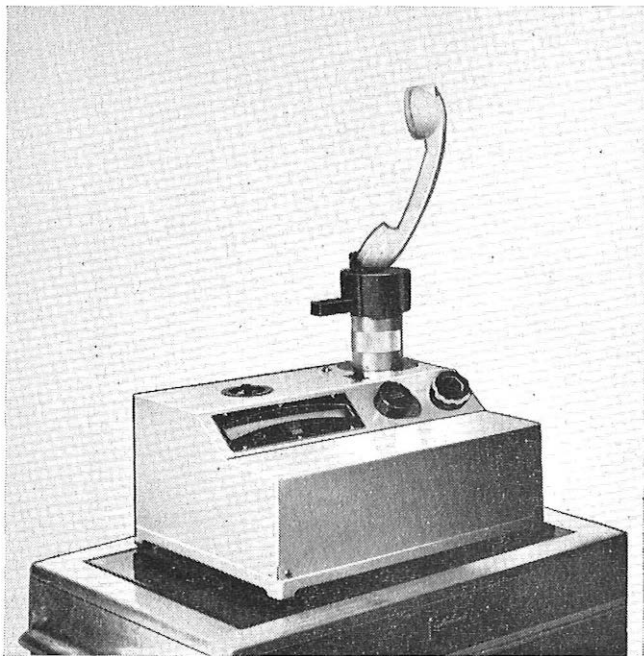

FIG. 1—PHOTOELECTRIC TRI-STIMULUS COLORIMETER

depend on the judgment and skill of the operator. There are limits to their accuracy, chiefly because the filters do not completely shut off unwanted regions of the spectrum. The instrument is comparatively cheap and experience has shown that it is reliable enough for most industrial colour control. A typical instrument is shown in use in Fig. 1.

By the use of a series of narrow-band filters it is also possible to obtain a spectral reflectance curve with this instrument as is done with the spectrophotometer. The band of wavelength passed by such a filter is, however, very wide compared with that obtained with the optical system of the spectrophotometer and a "flattened" curve is obtained. Such curves are useful for the study of metamerism which is discussed later. A set of curves obtained with the tri-stimulus colorimeter is shown in Fig. 2.

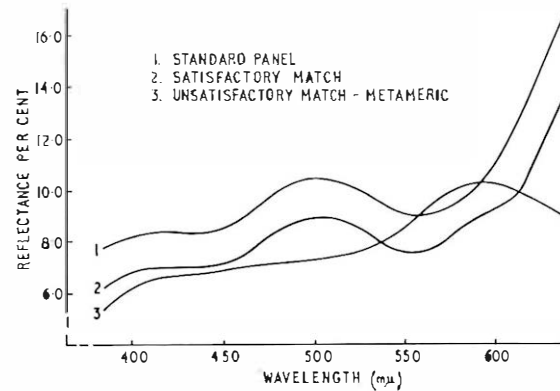

FIG. 2—TYPICAL SPECTRAL DISTRIBUTION CURVES OBTAINED WITH A PHOTOELECTRIC TRI-STIMULUS COLORIMETER

### CONTROL OF SHADE VARIATION

A photo-electric tri-stimulus colorimeter is used in the London Materials Section to ensure that the tolerances allowed by the inspectors in different factories are within acceptable limits. Records are kept of colour measurements on all samples which have been regarded as doubtful and from the data thus obtained it is possible to express the permitted tolerances in numerical terms. In deciding on what tolerances shall be permitted it is necessary to recognize that small variations are much more obvious to the eye in some shades than in others and also that some shades are more difficult to control than others. With experience and reasonable care on the part of the moulder in operating the "dry-colouring" process, the existing tolerances can be met without much difficulty.

### METAMERISM

So far in this article only the colour of polymethyl-methacrylate mouldings has been discussed but other components used with the telephone, which are either made of plastic or of painted metal, are required to match the main body of the instrument. This requirement brought up the problem of metamerism. The word metamerism in this context has a meaning which is different to that of chemical usage. A metameric match is said to exist when two objects match in one light and yet look different in another. The word metamerism is commonly used in this sense in colour technology and so far no alternative has been proposed.

Colour is as much a function of the quality of the light as of the surface from which it is reflected. The three illuminants in common use, tungsten-filament lamps, and daylight and fluorescent tubes, are markedly different in wavelength-intensity distributions so it is not surprising that surfaces viewed first under one and then under another appear to alter in colour. An extreme example is the great difference to colours produced by the light of the sodium-vapour lamp in street lighting. The light from this source is completely lacking in certain parts of the visible spectrum. What is less obvious but equally true is that two grey objects, e.g. one of which has been pigmented only with black and white pigments and the other with a carefully balanced mixture of red, blue and green pigments, will alter with a change of quality of illumination but to a different extent.

The phenomenon was first encountered in the plasticized polyvinyl-chloride coiled telephone cords which are required to match the case. The first samples seen were strongly metameric and this was particularly noticeable in the topaz and elephant-grey colours. Because of differences in the basic nature of the two polymers different types of pigments are normally used for colouring polyvinyl chloride and polymethylmethacrylate. As explained above, attempts to produce the same shade by mixing different sets of pigments will almost invariably produce a metameric match. Fortunately, it was found to be possible to use the same pigment mixture in both materials and a satisfactory match was then obtained without any difficulty. The experience gained in solving this problem enabled the metameric problem to be solved without difficulty when it arose in connexion with the other components.

The colour elephant grey is the one which has produced the most interesting metameric matches. This colour is specified for the paint finish for auxiliary equipment for the new telephone. A paint manufacturer would normally produce such a shade by mixing a white pigment with a black iron oxide or carbon black and small amounts of a yellow. These pigments are not suitable for plastics where smaller amounts of high-grade pigments are used. The first efforts of the paint manufacturer were excellent matches in the "north daylight," which is accepted as standard for colour-matching of paints, but strongly metameric in other lights. Again it proved possible to use the same pigments as had been

used in the plastic and there was then no trouble, although it occasionally recurs when painting is done by a subcontractor who does not understand the requirement.

A metameric match can be detected easily enough by comparing the sample with the standard in two different lights, for example, in daylight and ordinary artificial light. A spectral reflectance curve of the type described above will often be helpful in diagnosing the source of the trouble but as a rule it can be said that if the correct pigments have been used there will be no metamerism; if they have not, there is little difficulty in deciding that metamerism is present. For this reason it has not been necessary to fix acceptance limits for this property.

The paint industry and others to whom colour is of importance are careful to specify the type of light to be used for colour matching. Even "north daylight" varies and standard light sources are specified in great detail. This is, however, a tacit admission that the colour matches obtained in this way will not in general be valid for other lights, that is to say for most of the time they are in service. The Post Office requirement of a match which shall be valid in all lights, although apparently novel to the paint industry, effectively simplifies the problem. In practice, the manufacturer has to use one pigment mixture, but once this is accepted the type of light used for colour matching is no longer important, within wide limits, and a more serviceable match is obtained.

#### CONCLUSION

Work continues on the instrumental control of colour, and experience gained in the colour control of the telephone is being applied to other parts and to other materials. This type of problem can only be solved by collecting data over a period to determine how close to the standard it is reasonable to ask the manufacturer to keep. The answer must vary according to the material in question and the manufacturing process. The paint industry, for example, is accustomed to work very closely to a colour standard; "no perceptible difference" is everyday practice for them. The plastic manufacturer has, admittedly, a harder task and must be allowed more latitude. However, the type of approach outlined above has proved reasonably successful in controlling the colour of the polymethylmethacrylate telephone.

---

## Book Received

"Six-language Dictionary of Automation, Electronics and Scientific Instruments." Technical terms in English, French, German, Italian, Spanish and Russian. Compiled by A. F. Dorian. Iliffe Books, Ltd. 732 pp. 105s.

The technology of automation, electronics and scientific instruments has given rise to a considerable number of new words and phrases, coined in recent years to describe new equipment, materials, components and techniques. These have their own specialized meanings and cannot be found in any ordinary dictionary; this leads to difficulties in reading and understanding foreign technical literature.

The purpose of this dictionary is to enable anyone, whether engineer, scientist or technologist, to understand the latest technical publications in any of the six principal

languages of which he already has a basic knowledge. It has been compiled by a team of multi-lingual technologists who are fully conversant with the technical phraseology of modern industry.

The dictionary is divided into six parts—English, French, German, Italian, Spanish and Russian—and the English part is treated as the key glossary with equivalents in the other five languages. In many instances the user will find that to each English entry there is more than one entry in the corresponding language. This has been done purposely in order to avoid rigidity, for it presupposes a reasonable working knowledge of the language being used.

The preface, which has also been translated into the five languages, gives full instructions for the use of this dictionary which, with its 5,500 English phrases and nearly 65,000 foreign equivalents, should prove valuable to all interested in technical development in automation and electronics.

# The Extraordinary Administrative Radio Conference, Geneva, 7 October–8 November, 1963

U.D.C. 061.3:621.396

THE decision of the Administrative Council of the International Telecommunication Union (I.T.U.) to call a Conference at this time to allocate frequency bands for space radio-communication purposes indicates the importance now attached to the need to establish a firm basis of international regulation which would allow, with minimum risk of interference, transmission of signals to and from man-made objects in space, and scientific study of radio-waves generated naturally in space, by all countries wishing to take part in such activities. The agenda for this Conference focused attention on the radio-spectrum needs of space science as well as the needs of operational communication, navigation and meteorological satellites.

The Conference was attended by some 400 representatives of 76 Administrations, as well as observers from certain United Nations Agencies and scientific bodies. The United Kingdom Delegation of some 20 persons, led by Capt. C. F. Booth, C.B.E., former Deputy Engineer-in-Chief, included members of the Engineering and Radio Services Departments of the Post Office as well as representatives of the Ministry of Defence, Ministry of Aviation, the War Office, and the Department of Scientific and Industrial Research.

The tasks set for the Conference were completed with notable amity and success within the scheduled period of 7 October to 8 November; with impressive ceremony, the Final Acts were signed at five minutes to midnight on the final day. That it was possible to get through the work and to reach agreement in a period of five weeks was due entirely to recognition that it was in the common interest of all nations to lay a firm foundation for the development of space science and space operations. The Final Acts of the Conference are in the form of amendments and additions to be read in conjunction with the Radio Regulations drawn up by the Ordinary Administrative Radio Conference, Geneva, 1959. They will become effective on 1 January, 1965.

The radio frequency spectrum is, of course, now heavily committed even up to frequencies as high as 40 Gc/s, so that although it would be desirable to allocate exclusive frequency bands to the new and developing technology of space radio communication, this is clearly impracticable. Much of the work of the Conference was concerned, therefore, with problems of inserting new space services into bands already occupied, without unacceptable mutual interference between the various services. In this connexion, it relied greatly on the relevant technical studies and recommendations produced at the February 1963 meeting of the C.C.I.R.†

Spectrum space had to be found for space research, satellite-identification signals, radio astronomy, telemetry, command, tracking, radio-navigation satellites, meteorological satellites and communication satellites. As the mutual tolerance to frequency sharing with terrestrial services varies enormously, and as there is a considerable divergence of spectrum allocation between the three recognized radio regions of the world, the allocation problem was a most difficult one; to solve it required

goodwill, a spirit of give-and-take on the part of all delegations and considerable reconciliation of all the widely differing interests involved.

The technical work of the Conference centred largely on the determination of fair and reasonable sharing criteria and, in particular, the limitations to be imposed upon terrestrial and space services sharing frequency bands in the range 1 to 10 Gc/s. Power limits were specified for terrestrial service transmitters in order that interference with space-station receivers can be kept at an acceptable level. On the other hand, the maximum flux density produced at the surface of the earth by communication—and meteorological—satellites was determined to ensure that interference with the receivers of terrestrial services will be kept down to an acceptable level. Similarly, limits were laid down for the horizontally-radiated power and for the minimum angle of elevation of an earth-station aerial.

When different services are to share a common or overlapping frequency band some co-ordination between these services is needed at the planning stage. This is specially important when more than one Administration is involved. A procedure was, therefore, agreed whereby an Administration planning to install an earth station of a communication-satellite system will calculate a "co-ordination distance" around the earth-station site and advise any other Administration included within the contour. Administrations will also advise each other of plans for communication-satellite and terrestrial services that may have mutual interference potential and take such steps as may be necessary to avoid interference.

Negotiations about co-ordination procedure involved the rapid preparation at the Conference of numerous and complex graphs; to have done the calculations by hand would have taken too long, so the expedient was adopted of transmitting basic data from Geneva to Goonhilly by telex, performing mathematical operations on the computer at Goonhilly and telexing the result—within two hours—to Geneva.

In the foregoing paragraphs, attention has been focused mainly on the technical and frequency-allocation aspects of the Conference, but its work also included the difficult task of formulating clear and unambiguous regulations amending or replacing those included in the Radio Regulations, 1959, which cover notification and recording of frequency assignments in the Master International Frequency Register, co-ordination procedures, action to be taken in the event of dispute, notification of station characteristics and so forth.

Those who were privileged to play a part in the Conference were impressed by the growing awareness of the part that space radio communications may play in the everyday activity of man in the latter decades of the twentieth century. This awareness, vivid and imaginative in the nations already heavily engaged in space, is now becoming appreciated by the developing nations. The Conference, therefore, in its success in what may seem to be a specialist activity, permits the planning of these wide-ranging facilities and scientific studies to proceed upon a firm and internationally-agreed basis.

J.H.H.M. and F.J.D.T.

†C.C.I.R.—International Radio Consultative Committee.

# Raising and Setting Manhole and Joint-Box Frames and Covers Using Polyester Resin

A. F. L. HEARN†

U.D.C. 621.315.233 : 624.027

The increasing speed and volume of modern traffic has made it desirable to reduce to a minimum the periods of carriageway obstruction due to Post Office works. This may be partly achieved by the use of polyester-resin cements and pre-cast concrete blocks for raising frames and covers to a new level and for renewals of worn frames and covers.

## INTRODUCTION

IN 1958, owing to the continued growth and increased speed of traffic, the Post Office introduced unit-type frames and covers\* as standard for carriageway use together with an improved installation technique, to enable their better wearing and loading characteristics to be utilized.

### Present Method of Installation

Unit-type frames and covers are supplied with the frame seatings bolted to the cover. To install these frame-and-cover units, light shuttering is set up around the manhole or joint-box opening. The units are assembled over the manhole or joint-box opening and adjusted to the carriageway level by means of levelling screws.

Concrete is poured around and under the frame, and a head of concrete is maintained to ensure that the concrete flows beneath the frame seatings. Fig. 1 shows a

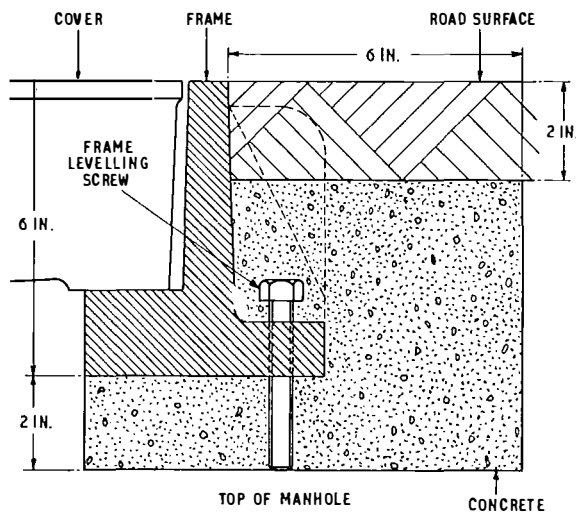

FIG. 1—SECTION THROUGH UNIT-TYPE FRAME AND COVER WITH CONCRETE USED AS SETTING MEDIUM

section through a unit-type frame and cover installation using concrete. This method of installation, although satisfactory, does, however, require a minimum period of 24 hours after placing the concrete before the frame and

cover can be exposed to traffic, even when high-alumina cement is used. If rapid-hardening or Portland cement is employed periods of 3 and 7 days, respectively, must be allowed. While delay in removing an obstruction due to such work is most undesirable, it becomes a matter of major importance when frames and covers are being renewed or raised due to a change in road level.

Because of the need to minimize the length of time that guards and warning lamps are required whilst the concrete is setting, consideration has been given to the possible use of materials other than concrete for setting frames and covers. A high-strength polyester resin, manufactured by Artrite Resins, Ltd., under the trade name of Certite and used for jointing concrete sections in civil engineering, was thought to have possibilities, and tests of the material were carried out.

## DESCRIPTION OF RESIN

The adhesive material used consists of a synthetic resin and a hardener which is compounded from various additives to give products, when mixed, of the form of syrup or mortar.

The synthetic resin belongs to a group known as polyester resins. Organic acids can be combined with alcohols to form products known as esters, an example being ethyl acetate, a solvent used in cellulose paints, which is made from alcohol and acetic acid. Certain acids and alcohols, however, instead of forming simple esters can be made to form long chains of alternating acid and alcohol molecules; these chains are known as polyesters.

The structure of the long-chain molecule can be illustrated thus:



The polyesters used in this resin incorporate certain acids containing groups that allow the acids themselves to join together, provided a suitable chemical is present to form the link. Styrene, a liquid, acts both as a solvent for the polyester resin, which is a solid, and as a chemical bridge between the chains. It is the formation of these cross links between chains that causes the liquid resin to become a hard inert solid. Thus the solvent is consumed and the process does not involve drying. This cross-linking is brought about by the addition of an accelerator and a hardener to the resin, though in the particular resin used for the tests the accelerator had already been added.

Additives are compounded with the hardener, each having a specific action in the mixture. There are blends of fillers to give the consistency required, pigments to give the colour, and the hardener itself is an organic peroxide that acts chemically on the liquid resin to convert it into a hard inert mass. The ingredients in the hardener also act as a heat "sink," absorbing the heat generated during the setting of the resin. This is vital as the resin has a low thermal conductivity, and during the hardening stage, before full strength is

†External Plant and Protection Branch, E.-in-C.'s Office.

\*JENNINGS, S. W., and HEARN, A. F. L. A New Frame and Cover for Carriageway Manholes and Joint-boxes. *P.O.E.E.J.*, Vol. 54, p. 164, Oct. 1961.



obtained, the high stresses set up could crack the resins if fillers were not used. For very large joints the use of an aggregate serves to reduce the thermal build-up in a quantity of the material and also reduces the amount of resin required. For setting the frame, a plastic aggregate is stirred into the syrup; as the aggregate floats in the resin, the mix can easily be poured under and around the frame.

#### Physical Characteristics

The material is supplied in three parts to be mixed on site just prior to use. These are:

- (i) Resin—a thin blue liquid.
- (ii) Hardener—a fine white powder.
- (iii) Powder—a fine grey powder.

By careful choice of the right proportions of resin and hardener, the setting time can be arranged to be between  $\frac{1}{2}$  hour and 2 hours to an accuracy within 5 minutes.

The amount of hardener required will vary with temperature, but tables are available so that the necessary adjustment of the amount can be made. At the same time the compound can be adjusted from a pourable mix to an easily spreadable mortar by the addition of suitable amounts of powder.

Fig. 2 shows the compressive strength of the material compared with various types of cement mortars.

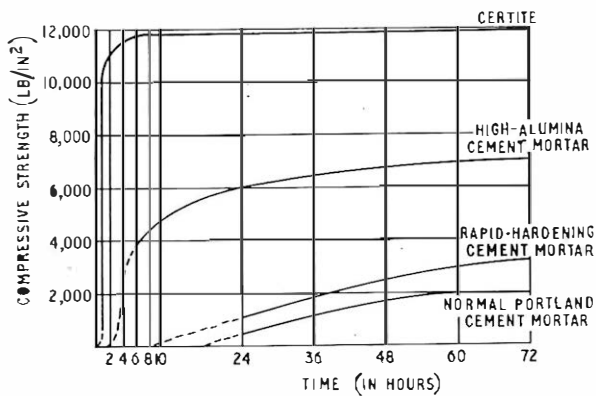

FIG. 2—COMPRESSIVE-STRENGTH CHARACTERISTICS OF VARIOUS CEMENT MORTARS

Mechanical tests were made on a test sample after 24 hours with the following results:

|                        |   |                            |
|------------------------|---|----------------------------|
| Compressive strength   | = | 18,500 lb/in <sup>2</sup>  |
| Tensile strength       | = | 2,350 lb/in <sup>2</sup>   |
| Resin-to-concrete bond | = | 110–200 lb/in <sup>2</sup> |
| Resin-to-steel bond    | = | 3,180 lb/in <sup>2</sup>   |

#### TRIAL INSTALLATIONS

Initially, the technique for normal concrete installation was followed and some difficulties were met, due to the fluidity of the resin, in retaining it within the shuttering and under the frame sections. Discussions with the manufacturer resulted in the viscosity of the fluid being raised and the promise of suitable additives to enable the fluid to be converted into either mortar or concrete.

After several trials it was realized the future of the method lay in its application to renewals and the raising of frames and covers made necessary by alterations in road level; it is not possible to exploit the advantages of

resin on new work owing to the time required for the other concrete used in the construction of the joint-box to mature. After consideration it was thought that the best method of raising frames and covers was to employ pre-cast concrete blocks as a raising medium and use the resin for jointing the concrete blocks and setting the frame. It should be noted that the frame must be in a clean unpainted state as a chemical action takes place between the usual bitumastic coating and the resin, and in trials to date the frames have been shot-blasted.

To illustrate the use of the resin, the method of raising a frame and cover in the Brighton Telephone Area is described.

#### Brighton Trial Installation

A frame and manhole cover had been covered with 3 in. of rolled asphalt by the local authority, and access to the manhole was urgently required. Due to the depth of the old frame and cover and the covering of asphalt a lift of 13 in. was necessary. As concrete blocks of this depth and size would have been prohibitive in weight it was decided to cast two separate blocks each 6 $\frac{1}{2}$  in. deep.

The top block was designed with a rebate to contain the resin when setting the frame and cover, and of such a size as would minimize the backfill required. The bottom block was made similar in size but without a rebate and was provided with steel dowels so that the two blocks could be aligned easily. Both blocks were provided with cemented-in screwed sockets to facilitate easy raising and lowering on to the manhole shaft by means of screwed eyebolts.

A start was made at 8.30 a.m. and the old frame and cover were cut out and removed, leaving the excavation a little larger than the overall size of the pre-cast concrete blocks. The top of the shaft was levelled-off and cleaned of old mortar. The top of the shaft was trowelled with a  $\frac{3}{4}$  in. layer of resin mortar of 45 minutes setting time and the first concrete block lowered into position (Fig. 3). The block was pressed down until the excess

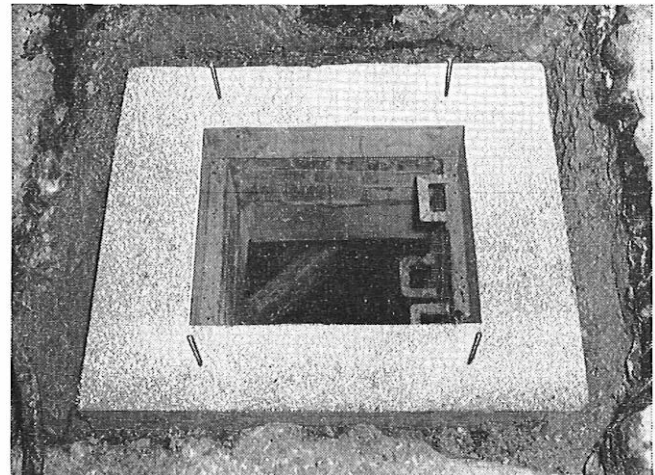

Note: Steel dowels used to ensure alignment of top block  
FIG. 3—FIRST PRE-CAST CONCRETE BLOCK IN POSITION

mortar was squeezed out, this being neatly trowelled off. Two small recesses had previously been cut in the top of the manhole shaft for a manhole step, which was inserted before the block was lowered. After the first

block had been placed in position it was covered with a  $\frac{1}{8}$  in. layer of resin mortar and the second concrete block lowered on to it. After a break for lunch the space between the concrete blocks and the sides of the excavation was filled with a very dry concrete mix placed in thin layers, each layer being well consolidated.

Rubber shuttering was then set up inside the top concrete ring as shown in Fig. 4 and secured to the

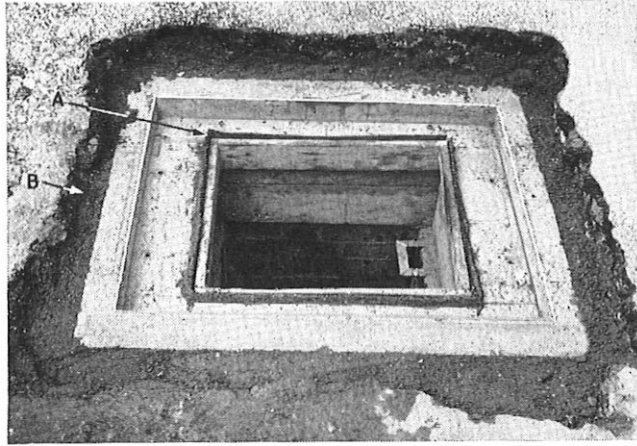

A—Rubber shuttering B—Dry concrete backfill

FIG. 4—BOTH CONCRETE BLOCKS IN POSITION WITH DRY CONCRETE BACKFILL AND RUBBER SHUTTERING TO RESTRAIN RESIN USED FOR SETTING FRAME

concrete with Evostick 528. The frame and cover were then placed in position and adjusted to the road level, which had a pronounced slope. Resin containing a polystyrene filler was then poured between the concrete shuttering and the frame until it was certain the space beneath the frame was fully filled. After a period of  $1\frac{1}{2}$  hours, normal reinstatement was carried out around the frame and the installation opened up to the evening rush-hour traffic.

Fig. 5 shows a section through a unit-type frame and cover installation using pre-cast concrete blocks and polyester resin.

#### CONCLUSIONS

Subsequent examination of trial installations has shown that they are in every way satisfactory, and it is considered that the use of polyester-resin cement may be safer than concrete on roads which carry very fast and heavy traffic, and where the maturing concrete is adversely affected by the vibration caused by fast passing traffic.

When considering the cost of using pre-cast concrete

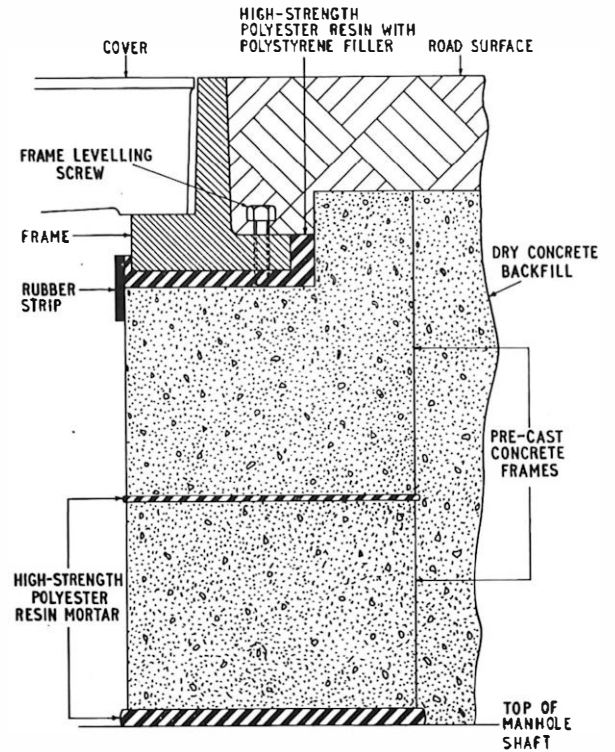

FIG. 5—SECTION THROUGH FRAME AND COVER INSTALLATION USING PRE-CAST CONCRETE BLOCKS AND POLYESTER RESIN

blocks and resin cement it has been found that in all cases there is some saving, this being most marked if guards and warning lamps would have been required for several days. This saving is, however, thought to be less important than the maintenance of good relations with local authorities by completing road works within a day, thus ensuring that the carriageway is not obstructed at night.

From the experience gained during the trials to date it is intended to design a range of pre-cast concrete blocks of such dimensions that they will meet all requirements for raising frames and covers and be of manageable size. It is also hoped to provide packs of resin, hardener and filler for specific requirements such as the installation of one, two or three unit-type frames and covers.

#### ACKNOWLEDGEMENTS

Thanks are due to Artrite Resins, Ltd., and to Messrs. Brickett and Jordan of Stuart B. Dickens, Ltd., for their assistance and help in producing suitable materials and for their assistance on site. The co-operation of Area engineering staff in the trial installations is also gratefully acknowledged.

# An Experimental 3-Digit Electronic Director Using Magnetic-Core Circuits

W. A. E. LOUGHHEAD, B.Sc.(Tech.), A.M.I.E.E., and G. A. MATTHEWS, B.Sc.†

U.D.C. 621.395.341.7:621.395.345

A 3-digit electronic director providing the same facilities as the electromechanical A-digit selector and the BC-digit director has been developed, and a prototype has completed over 2 years field trial. Not only does the equipment require less space and power than its electromechanical counterparts but the low fault rate during the field trial indicates that low maintenance costs can be expected for such equipment.

## INTRODUCTION

A 3-DIGIT electronic director providing the same facilities as the electromechanical A-digit selector and the BC-digit director has been on field trial at Balham automatic telephone exchange in the South West Area of the London Telecommunications Region since June 1961.

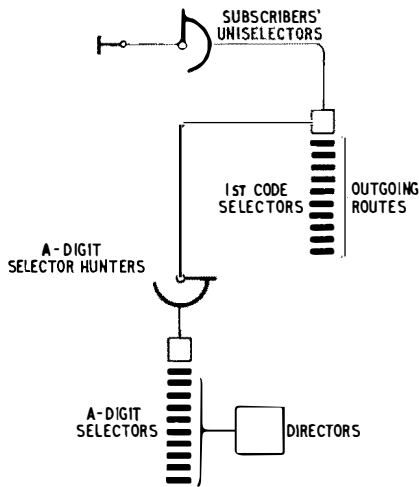

(a) Electromechanical A-Digit Selectors and Directors

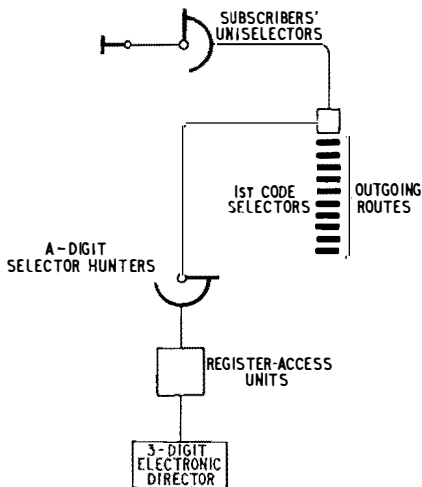

(b) Three-Digit Electronic Director

FIG. 1—TRUNKING ARRANGEMENTS FOR DIRECTORS

†Electronic Switching Division, Ericsson Telephones, Ltd.

Fig. 1 (a) shows the conventional arrangement, and it will be seen that when a handset is lifted the line circuit searches for and seizes a free 1st code selector. The associated A-digit-selector hunter then seizes the first available free A-digit selector, and dial tone is returned to the caller. On receipt of the A-digit, the A-digit-selector wipers are stepped to the appropriate level, where they switch into the bank to search for and seize the first free director. The director then accepts the B, C and numerical digits.

Fig. 1(b) shows the arrangement for the electronic director. The equipment is seized via register-access units connected to the outlets of the A-digit-selector hunters. When a free register-access unit is seized dial tone is returned to the caller, and the director receives and stores the dialled A, B, C and numerical digits. The number of register-access units required is approximately the same as the number of A-digit selectors required with electromechanical-type directors carrying the same amount of traffic.

In the electronic director the storage, and logical and switching functions are, in the main, carried out by square-loop magnetic cores.<sup>1</sup> The translation-field cores provide an exception in that they are not of square-loop material; the wiring configuration used when threading these cores provides permanent information storage. Transistors are used as switches and amplifiers; no thermionic valves or cold-cathode tubes are employed.

There is no evidence to show that the characteristics of the cores deteriorate with time, and transistors will give long service when operated under proper conditions. This is indicated by the fault analysis given in later paragraphs.

## OUTLINE OF FUNCTIONS OF ELECTRONIC DIRECTOR

Fig. 2 is a block schematic diagram of the electronic director. The central data store consists of a group of

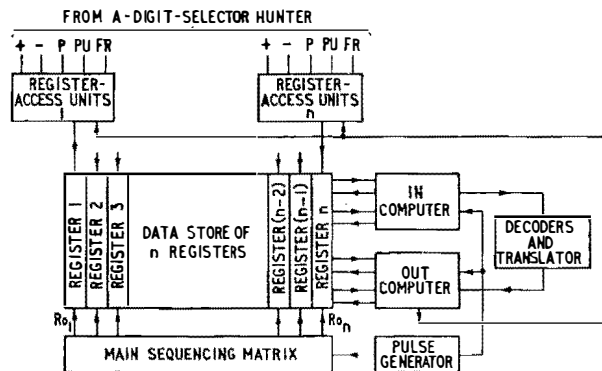

FIG. 2—BLOCK SCHEMATIC DIAGRAM OF ELECTRONIC DIRECTOR

<sup>1</sup>BANHAM, H., and HILLEN, C. F. J. The Use of Magnetic Cores in Logical and Memory Circuits. *P.O.E.E.J.*, Vol. 56, p. 46, Apr. 1963.

registers, the number depending on the amount of traffic carried by the exchange. Each register is directly connected to a register-access unit.

Each register-access unit is continually sampled in unison with its associated register by a scan pulse whose repetition rate has been chosen to give a scan pulse every  $16\frac{2}{3}$  ms. This value is suitable for interrogating the condition of the A relay in the register-access unit and also for timing the pulses returned by the "out computer" to the 1st code selectors via the register-access unit. Scan pulses  $Ro_1$  to  $Ro_n$  (see Fig. 3) are produced by the "main sequencing matrix," which applies them continuously to the registers and associated register-access units 1 to  $n$ . Each register is permanently associated with a particular scan pulse. The processing period allotted to each register in the "in" and "out" computers is  $16\frac{2}{3}/n$  ms.

The incoming dialled digits are stored in the register under the control of the in computer, and the three code digits are presented to the decoders and translator. The out computer accepts the routing digits, which are signalled in turn from the translator, stores them in the register and arranges for them to be pulsed out; these are followed by the numerical digits, and the director equipment is then released.

Each register in the data store consists of a column of 2 mm ferrite square-loop cores, which hold information in a 2-out-of- $k$  code,  $k$  being the number of cores, typically five, associated with each logic unit in the in and out computers. The number of cores in a register is approximately 100 and, therefore, in a 100-register system the store would consist of a wired matrix of 10,000 cores. With the constructional method used in this equipment the wired matrix has been subdivided into four matrix planes each consisting of  $50 \times 50$  cores.

The pulse generator provides the controlling pulses for the equipment.

The register-access unit provides the conversion required by the electronic director so that it may work into the electromechanical exchange. It also provides the necessary terminations and conditions for the +, -, P, PU and FR wires extended via the A-digit-selector hunter.

#### OPERATION

Information relating to the progress of calls is stored in the 2 mm ferrite cores, which are made up into register columns. The columns of cores are subdivided into groups of  $k$  cores each, and the corresponding group of  $k$  cores in each register column is associated with a logic unit in the in computer or the out computer.<sup>2</sup>

It is convenient for the purpose of explanation to consider the operation of one particular register,  $r$ , during a call, it being understood that the other registers are independently operated on by their respective scan pulses, which occur between the successive scan pulses  $Ro_r$  of register  $r$  (see Fig. 3).

When an  $Ro_r$  register pulse occurs, the information in all the cores for register  $r$  is transferred to the logic units.

<sup>2</sup>LOUGHHEAD, W. A. E., KAPOSI, A. (Mrs.), MATTHEWS, G. A., and WOODWARD, J. A. A Combined Counter and Decoder using Transistors and Magnetic Cores. *Proceedings I.E.E.*, Paper No. 2908E, International Convention on Transistors and Associated Semiconductor Devices, 1959 (Part B, Supplement No. 18, p. 1,244).

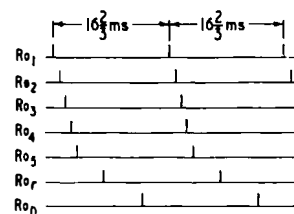

FIG. 3—REGISTER SCAN PULSES

At the end of the  $Ro_r$  scan period the modified information is returned to register  $r$  leaving the logic units ready to receive information from register  $r + 1$ .

#### The In Computer

When a caller is connected to the register-access unit associated with register  $r$ , the PU-wire signals are repeated by a relay, relay A, in the access unit, which thus indicates the state of the subscriber's circuit. While the subscriber's circuit is looped, a bias is applied to a sensing core associated with the A relay (see Fig. 4), the

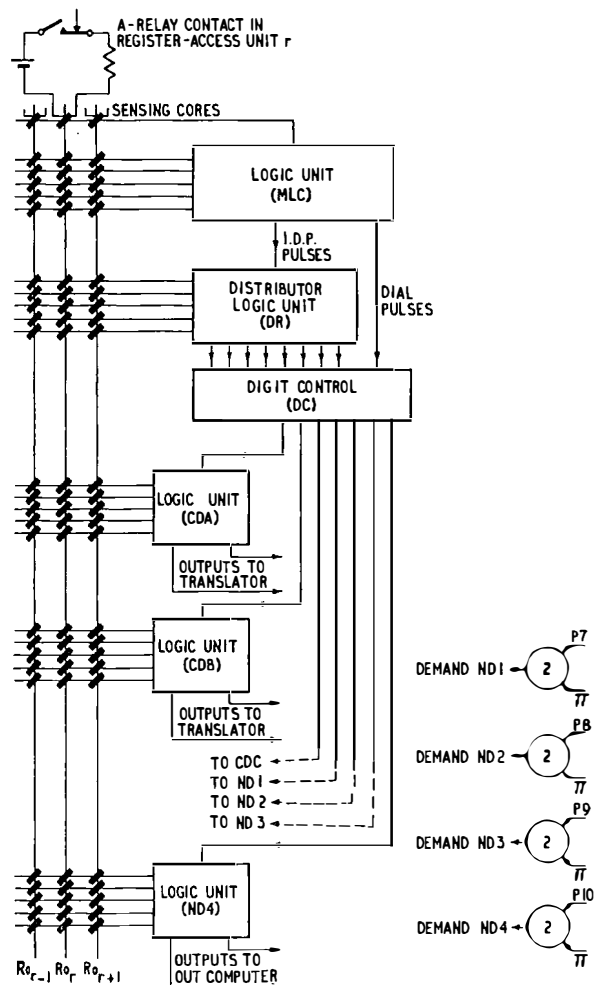
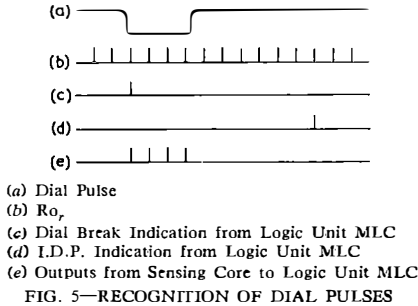

FIG. 4—"IN" COMPUTER

output of the sensing core being connected to a logic unit called the "make-length counter" logic unit, MLC. When the scan pulse  $Ro_r$  is applied to the register no output is obtained from the sensing core and hence there

is no input to logic unit MLC (see Fig. 5, waveforms (a), (b) and (e)).

During the period when the dial contacts are open, relay A releases and the bias is removed from the sensing core. Outputs are then obtained from the sensing core by the scan pulses  $R_{0r}$  and are passed to logic unit MLC, which produces a single output to indicate one dial break pulse (Fig. 5, waveform (c)). When the dial contacts



close again the inputs to logic unit MLC cease. This process occurs for each pulse transmitted by the dial contacts. Following the last pulse of a pulse train, and after a fixed interval, a separate single output pulse is produced from logic unit MLC (Fig. 5, waveform (d)) to indicate the inter-digital pause (i.d.p.). In this manner the incoming dial pulses and the i.d.p.s are converted into pulses which occur at the scan time of the register.

The "distributor" logic unit, DR, in conjunction with the "digit-control" unit, DC, organizes the routing of the dial pulses representing the three code and four numerical digits to logic units CDA, CDB, CDC and ND1-ND4, respectively. Distributor DR steps on one position for each i.d.p. pulse received from logic unit MLC, thus indicating the completion of a digit and preparing for receipt of the following digit. The logical operations involved in the functioning of distributor DR and control DC are carried out by magnetic-core circuits.

When the A-code, B-code and C-code digits have been received they are presented continuously to the translator by logic units CDA, CDB and CDC, respectively.

### The Decoders and Translator

A simplified diagram of the decoders and translator is shown in Fig. 6. The first decoding matrix, M1, consists of a wired array of square-loop metal-tape cores. The simultaneous application of the stored A-code digit to the selected column and the stored B-code digit to the selected row causes the core at the intersection of the row and column to switch and produce an output. Without further amplification this output is applied to a column in the second decoding matrix, M2, which is a further wired array of square-loop metal-tape cores. Simultaneously with the application of the A-code and B-code digits to matrix M1, the stored C-code digit is applied to the selected row of matrix M2 so that the core at the intersection of this row and the selected output from matrix M1 switches and produces an output from matrix M2. This output from matrix M2 therefore represents, as a pulse on a single wire, the three code digits stored in the CDA, CDB and CDC logic units.

The outputs from matrix M2 are connected without further amplification to the translator, which consists of an array of ring-type transformer cores, each contained in a suitable moulding. The material of these cores does not exhibit a square hysteresis loop and is of the type normally used for small power transformers. In Fig. 6 the translator array is shown as consisting of three rows of cores, each row having at least 10 cores numbered 1 to 0. The purpose of the  $\beta$  and code-only cores will be explained later. Each row represents one routing digit. Every core is provided with an output winding, and each column of similarly-numbered cores has its output windings connected to a common output point. This is represented in Fig. 6 by the single vertical line through each column of cores.

The selected output of matrix M2 is available on a single wire which is threaded through one core in row 1 of the translator, one core in row 2 and one core in row 3, and is finally terminated at earth potential. Each routing-digit row is marked in turn by the out computer as pulsing-out proceeds.

The selected output wire of matrix M2 has a current pulse produced in it when its associated core in matrix M2 switches. This current pulse tends to induce a pulse in the output windings of the translator cores through which the wire is threaded. The induced pulse is made available at the common-output point associated with the core in the marked row, thus representing the routing digit, but no output pulse appears in the output circuits of the other two rows not marked. As an example, using Fig. 6, suppose that the code digits dialled and stored were 122; core 12 in matrix M1 and core 122 in matrix M2 switch. Because the output wire of core 122 is threaded through core 1 of row 1, core 9 of row 2, and core 3 of row 3, the routing digits 1, 9 and 3 are made available in turn to the out computer for pulsing out when the rows are marked in sequence.

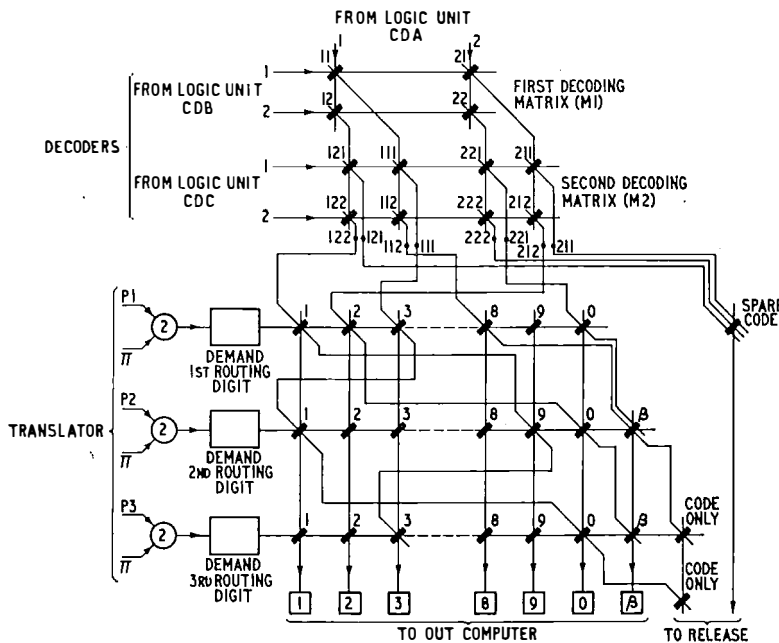

FIG. 6—DECODERS AND TRANSLATOR

The translations can be changed simply by re-threading the wires through the appropriate translator cores. As there is only one translation field, the changing of a single translation wire effects a translation change for the whole equipment. Matrix M1 can be a  $10 \times 10$  matrix of 100 cores providing 100 separate outputs to matrix M2, which can be a  $10 \times 100$  matrix of 1,000 cores, thus giving 1,000 separate outputs to the translator.

In the field-trial equipment at Balham there are six rows of cores in the translator providing up to six routing digits, though this is not the maximum number that can be provided.

### The Out Computer

The timing of the digits pulsed out by the director over the + and - wires of the register-access units is controlled by the 100 ms logic unit, C (Fig. 7), which

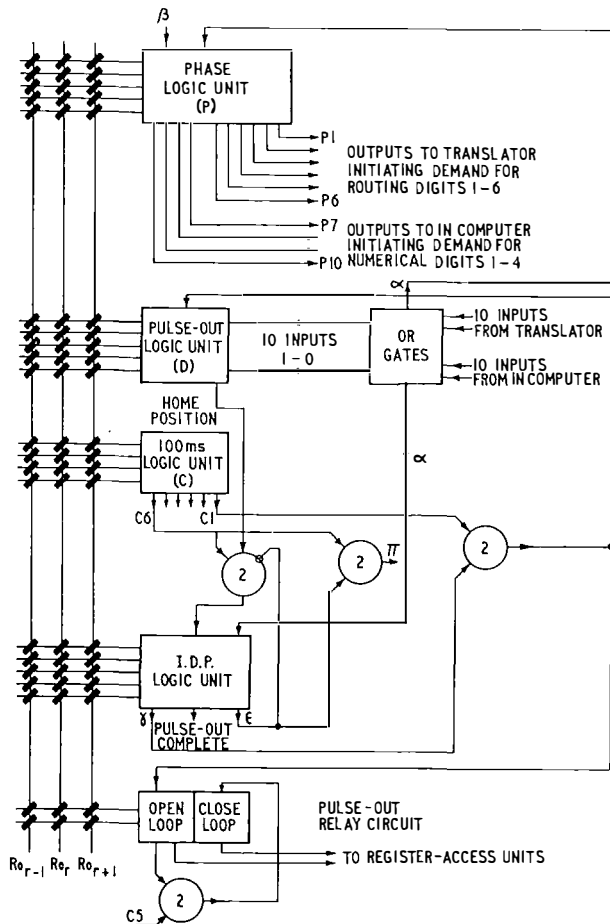

FIG. 7—"OUT" COMPUTER

generates pulses C1-C6,  $16\frac{2}{3}$  ms apart, each pulse recurring every 100 ms. The control of the pulsing-out procedure is carried out by the 10-state "phase" logic unit, P; the outputs P1-P6 of this logic unit initiate the demand for routing digits, and a further four outputs, P7-P10, initiate the demand for the numerical digits.

To simplify the following description, the signals provided by the i.d.p. logic unit have been modified slightly from those actually used in the field-trial equipment.

Initially, the i.d.p. logic unit generates a signal which

normally indicates the end of each i.d.p. period; this signal is called epsilon ( $\epsilon$ ). The epsilon signal is gated with C-logic unit output C6 to produce a signal termed pi ( $\pi$ ). At the same time logic unit P provides an output P1 and this is gated with the  $\pi$  signal (Fig. 6) to produce a further signal which demands the first routing digit. This demand is applied at the scan time of the register, and, when the three code digits have been stored, the demand signal results in the appearance of a pulse at one of the translator output terminals. This pulse constitutes the first routing digit.

The output pulses 1-0 from the translator are applied to the "pulse out" logic unit, D (Fig. 7), and each pulse can set the logic unit to the corresponding one of its 10 active states. Thus, the first routing-digit pulse sets logic unit D appropriately; at the same time a signal, alpha ( $\alpha$ ) is produced (see Fig. 7), which is an indication that a routing digit has been demanded and stored in logic unit D. Signal  $\alpha$  steps logic unit P from P1 to P2 and also causes the i.d.p. logic unit to cease producing further  $\epsilon$  signals and to produce instead, on a separate lead, a commence-pulse-out signal, gamma ( $\gamma$ ), whose initial appearance is coincident with signal C1. The signal  $\gamma$  occurs every  $16\frac{2}{3}$  ms, and signal C1 from logic unit C occurs every 100 ms. The  $\gamma$  and C1 signals are applied to an AND gate, and the gate output pulse, occurring every 100 ms, steps logic unit D towards its "home" state and also operates the pulse-out relay circuit. This process continues until the home position of logic unit D is reached, indicating that the first routing digit has been completely pulsed out. The output from the home position of logic unit D combines in an AND gate with output C6 from logic unit C to provide a signal to the i.d.p. logic unit. As a result signal  $\gamma$  ceases, and it is arranged that  $16\frac{2}{3}$  ms later the i.d.p. logic unit will commence to count eight 100 ms periods; this is controlled by the logic-unit input, which itself occurs once every 100 ms. When the i.d.p. period is complete, the signal  $\epsilon$  reappears, and the input and AND gate of the i.d.p. logic unit are inhibited.

The next time output C6 of logic unit C appears it combines as before with signal  $\epsilon$  to produce signal  $\pi$ ; this combines with output P2 to demand the second routing digit. The process continues until all the six routing digits have been pulsed out.

When the six routing digits have been pulsed out, logic unit P is at position P7, and output P7, together with signal  $\pi$ , demands the first numerical digit from logic unit ND1 (see Fig. 4). Logic unit D is set in the same manner as for a routing digit, and the pulse-out procedure continues as before until the four numerical digits have been pulsed out.

Some translations may have less than six routing digits. For example, in Fig. 6, the code 212 has only two routing digits, 2 and 0, and the translation wire is therefore threaded through core 2 in row 1, core 0 in row 2 and core beta ( $\beta$ ) in row 3, and is then terminated at earth potential. The output from core  $\beta$  is demanded and is derived in the same manner as for a routing digit; its function is to advance logic unit P to position P7 in one step so as to initiate the demand for the first numerical digit. This enables a positive indication to be given that there are no more routing digits, and at the same time reduces the delay that would otherwise occur before the numerical digits were pulsed out. If the dialled digits represent a code-only call, then the translation wire,

after being threaded through the appropriate cores in the rows, which may include core  $\beta$  if there are less than six routing digits, is passed through the code-only core prior to termination at earth potential. The output of this core initiates release of the director. The pulse-out relay circuit, as previously stated, receives a signal every 100 ms during the pulse-out period. An "open-loop" signal (see Fig. 7) is produced which operates the pulse-out relay in the access unit associated with the register. This open-loop signal is also applied to an AND gate, the other input of which receives the C5 signal from logic unit C. As a result, the gate generates an output signal  $66\frac{2}{3}$  after each open-loop signal, and this gate output operates on the pulse-out relay circuit to produce a "close-loop" signal that releases the pulse-out relay in the register-access unit. The make periods and break periods in the + and - wires are, therefore, accurately timed during pulsing out.

Normal release is effected in two ways:

- (a) By combining in an AND gate
  - (i) the output from logic unit P, which indicates that all routing and numerical digits have been pulsed out, and
  - (ii) the "pulse-out-complete" signal from the i.d.p. logic unit, 400 ms after the last numerical digit has been sent.
- (b) By combining in an AND gate
  - (i) the code-only core output.
  - (ii) the output from logic unit P, which indicates that all routing digits have been pulsed out, and
  - (iii) the pulse-out-complete signal from the i.d.p. logic unit, 400 ms after the last routing digit has been sent.

The output of either of these two gates is arranged via suitable circuits to operate the release relay in the register-access unit; the operation of this relay disconnects the P-wire and thus releases the director and register-access unit. Arrangements are incorporated to guard against premature reseizure of the register-access unit.

The register is forcibly released if it is held for more than 30-60 seconds after seizure or if a spare-code indication is received from the translator. An external clock pulse occurring every 30 seconds is used to time this forcible-release period, and a further clock pulse occurring every second is necessary so that the loop across the + and - wires may be opened for 1 second before earth is connected to the FR-wire in the register-access unit.

The pulse-out, release and forcible-release signals are common to all register-access units. The association of one particular register-access unit with a register is achieved by AND gating via square-loop cores the scan pulse R<sub>0</sub>, with the appropriate signal.

#### CONSTRUCTION

A front view of the electronic-director cabinet, with the covers of the top compartment removed, is shown in Fig. 8. The director, with the exception of the register-access units, is mounted in the top compartment. The in computer and out computer, main sequencing matrix and pulse generator are mounted on swinging frames. All circuits are wired in, and no plugs or sockets have been used. Maintenance is, therefore, carried out *in situ*, test switches and monitor points being provided on the front of the frames. The power consumption of this upper compartment is about 80 watts, and the

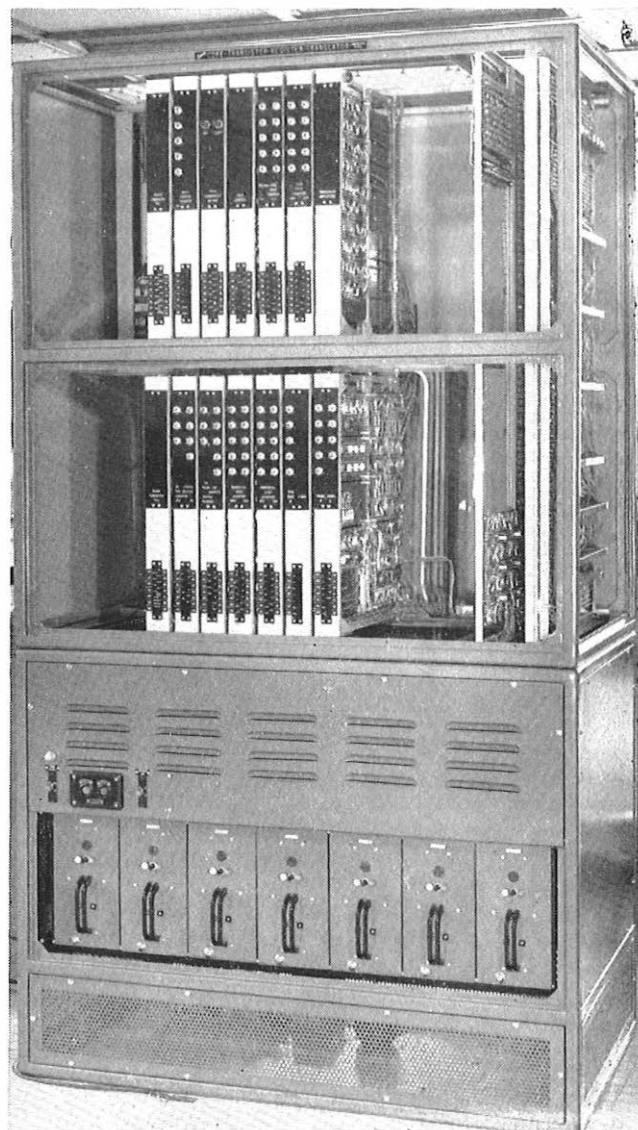

FIG. 8—FRONT VIEW OF ELECTRONIC-DIRECTOR CABINET

power-supply units are contained within the lower compartment, receiving their input from a mains rectifier unit with floated battery.

Fig. 9 shows the right-hand side of the upper compartment with the translation field fully wired for a typical London director exchange.

Fig. 10 is a rear view of the upper compartment. In the centre can be seen the data store (or registers) which, in a fully equipped 100-register scheme, would contain 10,000 cores arranged as four planes each of  $50 \times 50$  cores. This field-trial director has, however, been equipped with 10 registers, a number considered sufficient for trial purposes. The connexions from the backs of the swinging frames to the store can be seen, and, on the left, the rear of the decoder matrices M1 and M2 together with the cable form connecting the outputs of matrix M2 to the translation field are visible.

Situated by the side of the electronic-equipment cabinet at Balham exchange is a rack containing the 10 register-access relay-sets, a routiner, dial, meters and a digitron-display unit.\*

\*Digitron-display unit—number display unit.

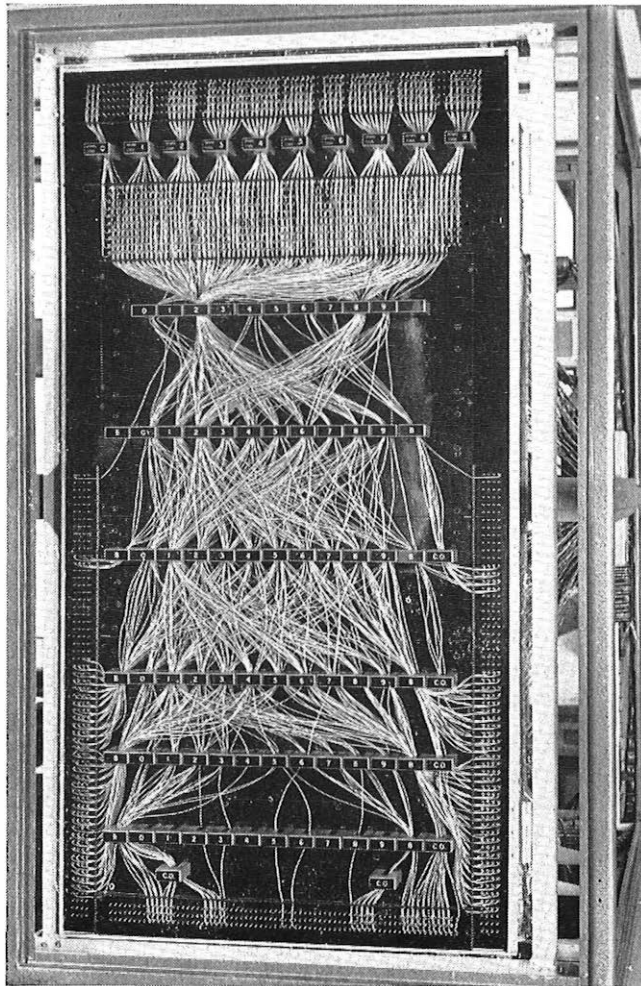

FIG. 9—TRANSLATION FIELD

#### EQUIPMENT TESTS

After a brief trial period in Ericsson Telephones, Ltd., laboratories, which established that the experimental director was operating correctly, the equipment was sent to the Post Office Engineering Department, Telephone Exchange Systems Development Branch, electronics laboratory for further tests in August 1960. Installation proved to be very straightforward: the director was functioning within 24 hours of its arrival, and the fact that no faults had developed during transit gives some indication that the method of construction is satisfactory for this type of equipment. In particular, it is considered that no doubts need be entertained as to the robustness of the square-loop cores, and their windings and terminations.

The temperature rise in the equipment proved to be less than  $5^{\circ}\text{C}$  in the upper compartment. The fault rate over the period of the test was very low; only one type of component failure (of a miniature electrolytic capacitor) was reported and no design faults have occurred. Tests of operation have been made in the presence of severe pulse interference such as that experienced in the vicinity of electromechanical switching equipment, and the results have been satisfactory.

#### FIELD TRIAL

The electronic director and associated rack were in-

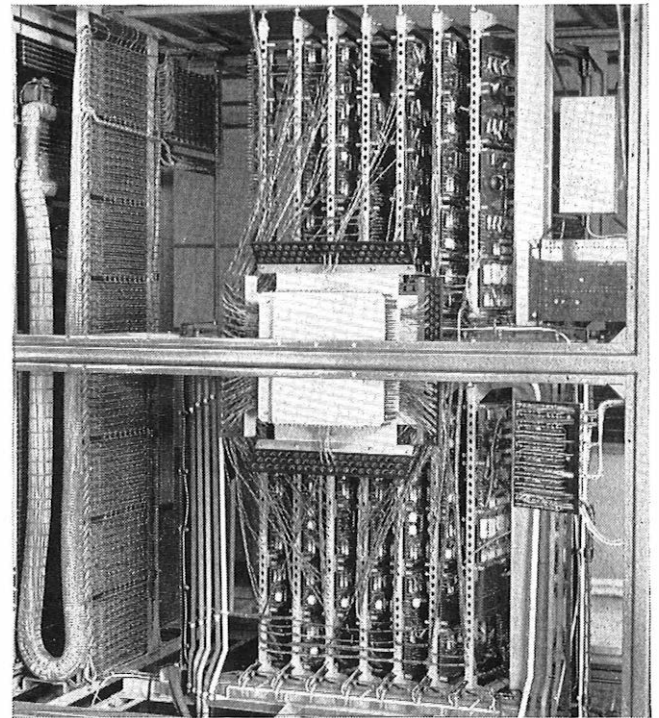

FIG. 10—REAR VIEW OF UPPER COMPARTMENT OF ELECTRONIC DIRECTOR CABINET

stalled at Balham telephone exchange in April 1961. The training of maintenance staff, and the flood testing and call-through testing of the equipment, were carried out prior to permission being given to switch the equipment into public service, which was done on 26 June 1961.

The electronic director is continually routine tested by an electromechanical routiner that was specifically designed for the purpose and which is mounted on the adjacent rack. The routiner makes three test calls in sequence, and the translation and release conditions received from the director are checked for correctness. The director is taken out of service if two incorrect calls are detected, but is returned to service at the end of a 3–6 minute period if a third incorrect call is not received within that period.

The director has been in public service since 26 June 1961, and in the period until 24 June 1963 it handled seven million subscribers' calls and five million routiner calls. During this period, in the electronic-equipment cabinet, there were 0.2 faulty components per 1,000 components per annum and 0.08 dry joints per 1,000 joints per annum; these faults caused the equipment to come out of service. In addition, five Zener diodes were changed in a power-supply unit, because its output had drifted outside its design limits; the diodes were changed as a precautionary measure by the maintenance staff after a routine check although the output drift had not affected service in any way.

#### CONCLUSIONS

The low fault rate exhibited by the equipment so far encourages an expectation of long life and low maintenance costs. The power consumption and space occupied by



the equipment are both substantially reduced compared with its electromechanical counterpart. The design of the translation field is such that translations can be easily and quickly changed.

Present designs include multi-frequency sending and receiving facilities, alternative routing, and a capacity of 200 registers per electronic-equipment cabinet.

The method of construction adopted was intended as an experiment for the field-trial model only; present designs are based on a cabinet containing easily replaceable slide-in units.

#### ACKNOWLEDGEMENTS

The authors are indebted to the Directors of Ericsson Telephones, Ltd., for permission to publish the article, to their associates in the sections of the Electronic Switching Division in which the electronic director was developed, to Mr. J. P. Harvey and colleagues of the Exchange Systems Development Department, and to members of the Post Office in both the Engineering Department (Telephone Exchange Systems Development Branch) and the London Telecommunications Region, South West Area.

## Book Reviews

"Permanent Magnets and Magnetism." Edited by D. Hadfield, Ph.D., M.Sc.(Eng.), F.I.M., M.I.E.E. Iliffe Books, Ltd. 12+556 pp. 289 ill. 105s.

Usually a book composed of a number of separate articles, by various authors, is a disappointment; but this time the method is a success. The team of authors is a strong one, and the coverage of the subject, without obvious gap or duplication, suggests that the editor did an excellent job either before or after the articles were written. He has also earned our gratitude for a good index.

A book on this subject was needed. Bozorth's Ferromagnetism, so good in most ways, has less to say about permanent magnets than one would wish, and this new book may well stand alongside it; it is good enough to do so without incongruity. Its scope is wider than that of Bozorth's book, however, in following the materials into their industrial applications.

There are chapters on the history of magnetism (entertaining, but also worth serious attention), on the theories of atomic magnetism and of domain structure, and on units, both C.G.S. and M.K.S. Then follow surveys of the available range of permanent-magnet materials, of the applications which they have found, and of the design of magnets for specific purposes. The manufacture of magnets is described, and their magnetization and testing. A chapter on magnetic stability falls less well into the sequence but it is a necessary and useful one. There is a brief history of the industry, a round-up of current research, and a cautious look into the future.

Every chapter is at least moderately good, and some are very good indeed. The timing of the book is fortunate, since it covers some recent developments (ferrites, single-domain particles, columnar crystallization) which may well be followed by a period of less rapid innovation. This will certainly be the standard work on its subject, and is unlikely to be superseded for a long time. A.C.L.

"International Series of Monographs on Electronics and Instrumentation, Vol. 14, Topics in Engineering Logic," Morton Nadler. Pergamon Press, Ltd. xv+231 pp. 129 ill. 60s.

Since 1955 there has been a substantial increase in the literature on the subject of mathematical aids to the design of logic circuitry. The problem of deriving a technique for determining the most economical method of realizing a logic function with the available hardware has been tackled by many authors but never with complete success. One technique is dependent upon the display of the requirements by 0s and 1s on a rectangular chart in which the rows and columns are appropriate to the generating variables (Marquand, Karnaugh or Veitch diagrams). The author has employed such charts and has developed techniques for deriving minimal realizations of logic

functions. It is doubtful whether his methods show advantages over alternatives such as those developed by McCluskey and Ashenurst but the graphical techniques may well appeal to students of a particular temperament.

A chapter is allocated to physical considerations and an attempt is made to define the minimal form. The chart method is developed to assist in the derivation of error detecting, correcting and comma-less codes. It is also employed in some considerations of sequential circuits involving storage. A chapter on redundancy concludes that duplication of individual elements is only suitable for equipment requiring a short life, but triplication with majority decision elements is preferable for equipment which must be maintainable over a long life.

The meanings of some of the more general statements are very difficult to grasp but these became clearer after further reading; however, the book provides an introduction which raises an interest for further study. A considerable bibliography is included. W.T.D.

"Servicing Transistor Radios and Printed Circuits," Leonard Lane. Iliffe Books, Ltd. 263 pp. 12 ill. 42s.

This book is intended as a simple introduction to transistors, their circuit applications, and methods of servicing transistor radios. It opens with six chapters, on semiconductor fundamentals, basic transistor principles, and transistor circuits. A further six chapters deal with servicing procedure.

The first six chapters are not well written as there is much needless repetition, and the treatment of basic principles is often inaccurate or misleading. There are some meaningless statements, such as on p. 13, "low resistance and high current are two ways of saying the same thing." The description on pages 19-22 of carrier transport in transistors ignores diffusion in the base region and is quite wrong. Most transistor-circuit engineers would not agree that, by comparison with the valve, "transistors are comparatively simple devices" (p. 37). Fig. 3.8 and 3.9 on p. 48 show bias circuits which would not work in practice. Fig. 12.3 on p. 237, illustrating the action of the photo-transistor, is also wrong.

The section on servicing is mostly sound and practical, and the precautions necessary in dealing with soldering and printed wiring are emphasized. However, there are some illogical procedures; on p. 99 replacement of the detector is suggested if distortion occurs on weak signals, a condition likely to result also from faulty operation of a class-B push-pull output stage. Also, on p. 133 the unsoldering of the battery lead at the on-off switch is recommended in order to measure battery current; surely this could be measured at the battery connector.

The book seems expensive and its standard is not thought to be high enough for Post Office engineering staff. H.G.B.

*I.P.O.E.E. Library No. 2727.*

# An Electronic Telegraph Buffer Store Using a Magnetic Drum

J. M. ROBINS, M.A.(Cantab.), A.M.I.E.E., and A. C. CROISDALE, M.B.E., B.Sc.(Eng.), A.M.I.E.E.†

U.D.C. 621.377:621.395.625.3:621.394.18

If an automatic error-correcting radio-telegraph circuit is used for the telex service it is necessary to provide temporary storage of the signals from the telex subscriber during periods of unsatisfactory radio transmission. Such storage has previously been provided by a rather complex machine using perforated paper tape. This article describes a store employing a magnetic drum, which meets all the requirements although it has a finite value of capacity. It has, however, the advantage of not using paper tape or of requiring expensive maintenance; in addition, it provides some useful new facilities.

## INTRODUCTION

THE general principles of automatic error-correction (ARQ) for radio-telegraph circuits have been described in this Journal,<sup>1</sup> and the system has become very widely used, particularly for telex services. However, the telex service has always required that a subscriber should be able to send a message in the normal manner, irrespective of the conditions of the radio path. When radio conditions are bad all effective transmission over an ARQ system ceases and it is necessary to store the subscriber's signals until automatic repetition has resulted in satisfactory transmission of the characters that could not previously be transmitted. A store is therefore needed that will accept start-stop characters, hold them indefinitely and release them one by one in correct sequence as the radio conditions permit. Consequently, the capacity that the store is required to have is determined by the duration of the telex call, the rate at which the characters are sent by the subscriber (nominally 400 per minute) and the number actually transmitted by the radio-telegraph system.

The store has hitherto been provided by a machine called a 5-unit receiver, transmitter and distributor (FRXD). This produces a perforated tape from the incoming telex (start-stop) signals and permits the signals to be re-transmitted by a reading head that can travel along the perforated tape and even read the latest character perforated. The tape between the perforator and the reading head forms a loop during bad radio conditions, but during good radio conditions the ARQ system reads and transmits 411 characters per minute, thus preventing the formation of a loop of tape. The ARQ equipment reads the tape as a 5-element simultaneous signal. It also interprets special supervisory signals from the "traffic-in-store" contact of the FRXD as well as continuous start polarity and continuous stop polarity on the subscriber's line.

By provision of a special bin, the paper-tape loop is held safely while waiting for the radio circuit to improve, and the capacity of this loop can be appreciable. In practice, however, it is found necessary to inspect the FRXD machines regularly to minimize paper jamming, because serious paper jamming can occur.

Nevertheless, the FRXD equipment does use large quantities of paper tape and is expensive to maintain.

Consideration was, therefore, given to alternative methods which could also provide additional facilities.

To provide storage equivalent to that of the FRXD, a buffer would have to possess a very large capacity, but there are several considerations which justify restricting the capacity.

In general, a telex call should only be set up if there is a reasonable circuit for transmission, since errors would occur during periods of low circuit-efficiency<sup>2</sup> and these would cause mis-selection in setting up the call as well as mutilation of the telex message. Confusion can also result from excessive delay in receiving acknowledgements.

The storage capacity required will depend on the operating conditions obtaining at the time. Even at maximum automatic-transmitter speed, characters can only arrive at the ARQ equipment store from a telex subscriber at a nominal 400 characters per minute. If, for example, the radio-circuit efficiency were as low as 50 per cent then the circuit would clear 50 per cent of 411 characters per minute. This would result in storing 400 - 205, i.e. 195 characters, per minute. As a compromise it has been decided that a store for 4,000 characters would suffice, and this would, in the above example, allow a message of up to 20 minutes duration to be stored.

Records show that about 7 per cent of telex calls exceed 20 minutes in duration, but, if precautions were to be taken to ensure that calls necessitating the use of a particular radio link were not set up when the radio transmission conditions were unsuitable, the possibility of exceeding the 4,000-character capacity of the buffer store would be very remote. In fact, this should only occur with complete failure of the radio circuit, and in such circumstances the call would have to be cleared down even if a FRXD were used. As a result, further measures are under consideration both to safeguard against setting up a call, and, during a call, to forcibly clear the call, if the radio-link transmission deteriorates.

## ELECTRONIC TELEGRAPH BUFFER-STORE DESIGN

To meet the requirements described it is necessary for the buffer store to accept a character arriving at a random instant and put it into a store, where it can either be read within one character period or held for up to 4,000 character periods before being read. The output signals are presented in parallel form, i.e. a group of five signals on five wires, corresponding to a particular 5-unit combination. The read-out instant is decided by the ARQ system, which sends a character-release pulse when each character is required to be transmitted.

The design of a suitable buffer store was based on a magnetic-drum store<sup>3</sup> and associated electronic circuits,<sup>4</sup> and permits writing-in to occur entirely independently of reading-out. A separate record of the stage each operation has reached is maintained, together with a lamp indication of how much storage is available at any time.

†Mr. Robins is with British Telecommunications Research, Ltd. Mr. Croisdale is in the Post Office Factories Department, but was formerly in the Telegraph Branch, E.-in-C.'s Office.

### Magnetic-Drum Store

The magnetic-drum store (Fig. 1) is a metal cylinder, rotating at approximately 1,800 revolutions per minute, the surface of which is coated with a hard oxide compound having remanent magnetic properties. Fixed to the drum mounting and separated from the cylindrical surface by a small gap are reading and writing heads.

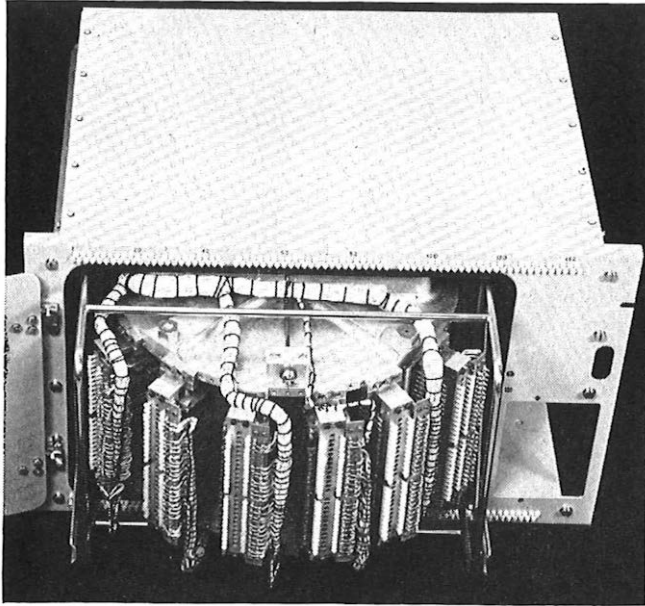

FIG. 1—MAGNETIC-DRUM STORE

By passing a suitable current waveform through a winding on a writing head, it is possible to impress a magnetic-flux pattern on the drum surface as it sweeps underneath, the flux pattern remaining in the drum surface until it is over-written by applying a further current waveform to the writing head. The circumferential strip of drum surface passing under a single writing head is termed a track. As the magnetic-flux pattern produced by the writing head of a particular track passes under a reading head associated with the track, it induces a voltage in a winding on the reading head.

By suitably controlling the phase of the current waveform in the writing head it is possible to store two kinds of information on a drum track—a 0 or a 1 (each termed an information bit). The two different flux patterns recorded on the track produce two different output waveforms from a reading head and thus the recorder 0 or 1 may be detected. Each bit stored occupies approximately 0.01 in. along the track. The drum chosen for this equipment is 9 in. in diameter and each track stores 2,796 bits. The drum is 5 in. deep and up to 100 tracks can be provided on it, but, to avoid too much dependence on one common unit, the equipment has been limited to six channel stores each using 10 tracks and not all the tracks are used.

### Timing Signals

During the writing and reading processes, it is necessary to be able to identify particular bits on a drum track. This is done by applying timing signals to electronic gating circuits in the writing-instruction and reading-indication paths. Provided that the timing signals occur at the exact instants that the required bits

are passing under the writing head or reading head, it is possible to write into, or read out of, particular bit positions on the drum track. These timing signals are generated by the drum-equipment clock, which consists of a number of electronic circuits whose timing is controlled and synchronized by the drum. Two drum tracks are used for this purpose: one of these tracks, known as the strobe track, has recorded on it 2,796 0s and is used to define each bit position on all other tracks, while the other track, known as the clock track, has recorded on it one 1 and 2,795 0s. The clock track is used to mark the first bit position of each track and to control the drum speed. By counting from the single 1 in the clock track each bit of any track may be identified. As a strobe track and clock track contain permanent information they are provided only with reading heads; duplicated tracks are also provided as a safeguard against failure, and change-over to these spare tracks may be made by means of soldered straps. All other tracks are provided with both a writing head and a reading head.

### Drum-Speed Control

The waveform read from the clock track, apart from the effect of the single 1 bit, is a continuous sine wave. The frequency of this waveform is directly proportional to the drum speed and, after the signal has been amplified, filtered and rectified, it is used to control the drum-motor drive voltage via a saturable reactor. In this way the drum speed could be kept to within  $\pm 1$  per cent of nominal, but, as such accuracy is normally not required, for economy a wider tolerance is allowed.

### Logic-Element Circuits

To facilitate the design and maintenance of the electronic system-logic, a set of basic circuits<sup>4,5,6</sup> was developed in association with the drum store. Using a few fundamental rules these individual circuits may be inter-connected by gates to provide circuits giving any required logical function. The individual circuits are mounted on printed-wiring boards which plug into

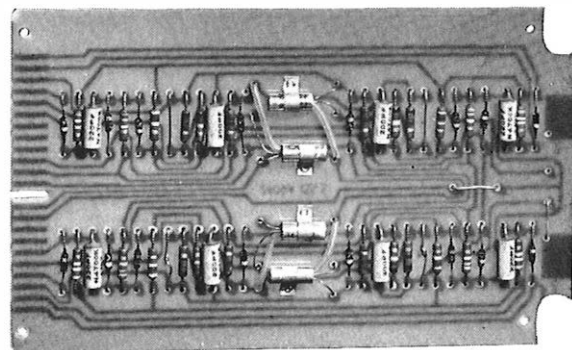

The dark lines show the principal connexions on the reverse side of the board  
FIG. 2—TYPICAL PRINTED-CIRCUIT BOARD

sockets (Fig. 2), and every board of one type is fully interchangeable with any other of the same type. The principal types of circuit are as follows:

- (a) Write circuit.
- (b) Read circuit.
- (c) Toggle.
- (d) Inverter.
- (e) Emitter follower.

*System Design*

Conversion of the incoming sequential telegraph signals to electronic signals suitable for storing on the drum takes place in an input circuit, one of which is provided for each channel input (see Fig. 3). This circuit can accept up to 47 per cent distortion of the in-

coming signal. The character is then temporarily stored on toggles—the character buffer-store—until the main store is ready to accept and store the character.

Each element of a telegraph character can be stored as one information bit on the drum, a 1 being recorded for start polarity and an 0 for stop polarity. Thus, a

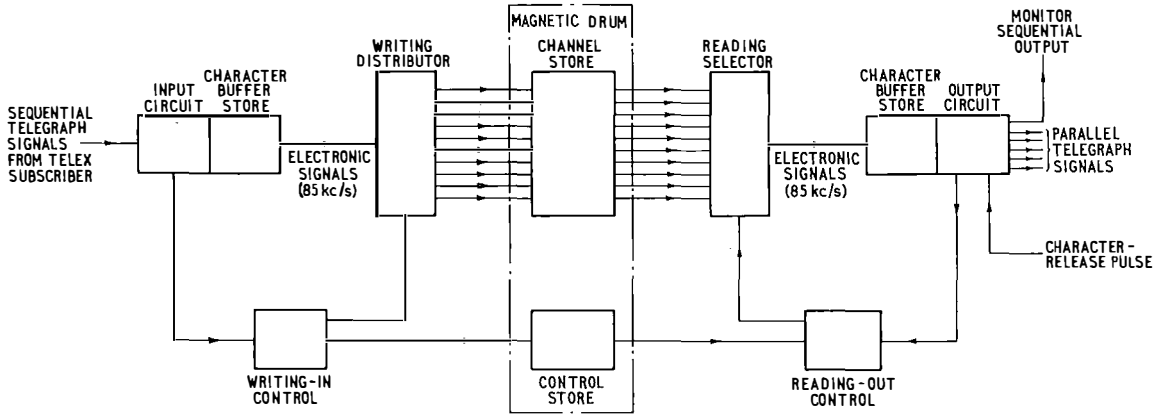

FIG. 3—BLOCK SCHEMATIC DIAGRAM OF ONE TELEGRAPH CHANNEL STORE

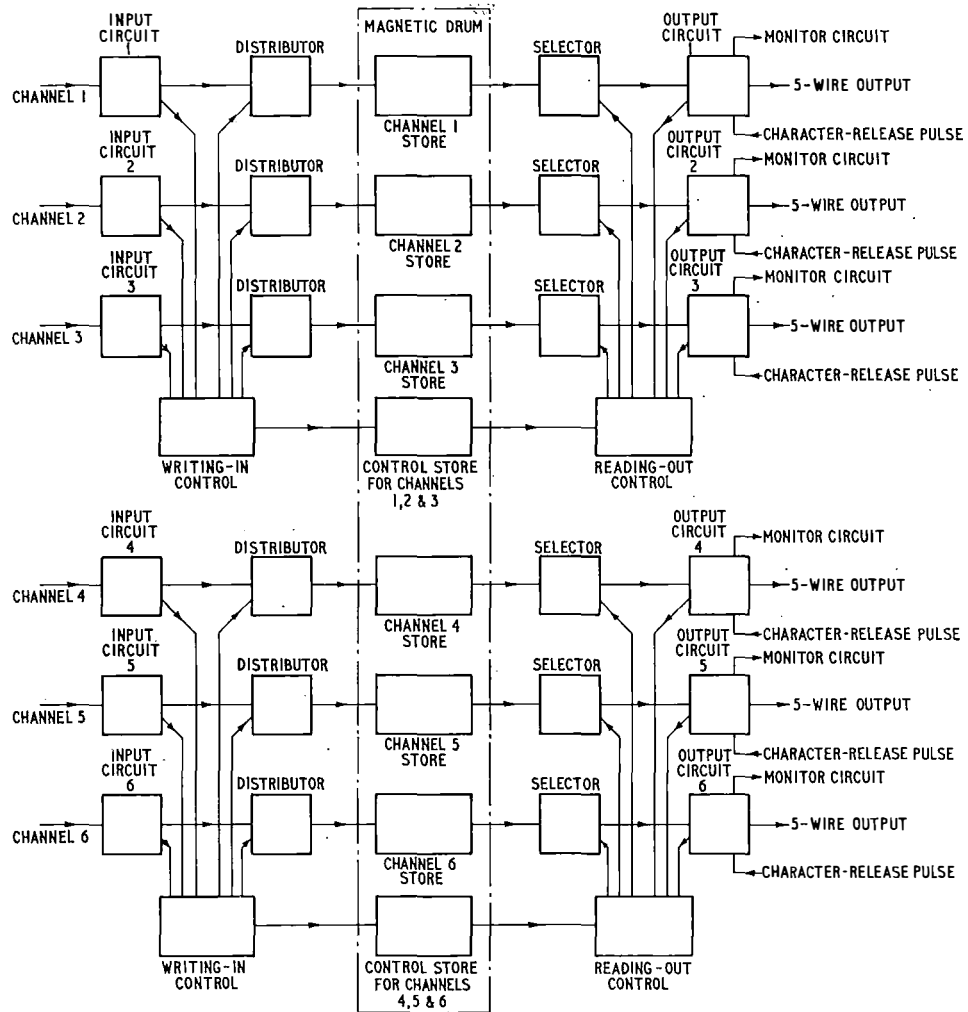

FIG. 4—BLOCK SCHEMATIC DIAGRAM SHOWING SIX CHANNEL STORES AND ASSOCIATED CONTROL STORES

character can be stored as five bits, but a sixth bit is required for supervisory signals. The track of 2,796 bits is, therefore, divided into 466 characters, each of six bits. The character positions at the beginning and end of a track are required for control functions and only 463 character positions are used for storage. To provide a channel store in excess of the specified 4,000 characters, 10 tracks are grouped together, giving a maximum storage of 4,600 characters plus 30 character stores reserved for reasons connected with recognizing the full-store condition.

In addition to storage tracks it is necessary to provide two control tracks and two delay tracks. These tracks are used to indicate the positions on the store tracks into which information has been written and also the positions from which information has been read. One control and one delay track, operating as a regenerative loop, are shared by three stores (see Fig. 4).

For each store of 10 tracks only one writing circuit and one reading circuit are used and these are connected by electronic switching circuits to the appropriate head on the required track, the operation being termed track switching. The writing-in of characters progresses cyclically through the 10 tracks. At the end of a telex call the store will have cleared all its traffic and the writing-in will have reached a random point in the store. For subsequent traffic, writing-in will commence from the point reached for the last call. With this arrangement the total storage capacity may be reduced by the capacity of one track but it will still exceed 4,000 characters. However, if the telex call is forcibly released, or if the reset button on the store equipment is pressed, the storing process resets to the start of the first track, any information stored prior to this is erased and the store is made ready to receive new traffic in less than 70 ms.

It is a requirement that no previous message should be read out even if a fault occurs in the drum circuits. This is achieved by arranging that on switching to a new track and before writing-in commences all the previous signals are erased, a positive check being made to ensure that this erasure has been carried out. If the check fails, an alarm is operated and further reading-out and writing-in is prevented.

When the output circuit receives a character-release pulse from the ARQ equipment, the next character is transferred from the output-character buffer-store to the output-character store, the latter store directly driving the circuits producing the parallel telegraph signals on the five output leads. The output-character store is also connected to a distributor that produces a sequential telegraph-signal output used for test purposes. Whenever the output-character buffer-store is cleared the channel-store circuits find and read out the next character from the channel store and put it into the output-character buffer store.

#### ADDITIONAL FACILITIES PROVIDED BY DRUM STORE

##### *Faster Setting-Up of Calls*

If a FRXD is used it is desirable to save wear by avoiding the continuous running of the machine when it is not being used to transmit calls. This requires a delay circuit to be provided in the telex control relay-set associated with the ARQ equipment so that, if the FRXD is not running, a suitable delay of 1-2 seconds occurs before the call is extended.

If the FRXD motor has to be started up for each call

- (a) the call setting-up time is increased,
- (b) ineffective time of trunk circuits is increased, and
- (c) the holding times of incoming and outgoing registers are increased.

These disadvantages become more serious with fully-automatic working, and the alternatives are

- (a) to run the FRXDs continuously and accept the resulting increased mechanical wear, or
- (b) to use a device to keep the FRXD running for a period of, say, 5 minutes after each call, so that, in general, during busy periods the motor is running at the start of each call; this adds complexity to the ARQ equipment.

Since the drum store is continuously available no delay is necessary in extending a call.

##### *Indication of Store-Occupancy Levels*

The method of recording the use of tracks, described earlier, provides a ready means of deriving indications of the used and unused capacity of each store, i.e. how full the store is at any instant. This information is displayed by lamps, but, in addition, any two preset points of occupancy may be detected by alarm devices, the devices being used by the operator (if an operator is employed on the circuit), or by automatic-switching control circuits, or for traffic-recording purposes. The points at which such devices should operate are variable, but the first alarm could, for example, be arranged to provide a warning to the telex operator that the radio path is causing delay in transmission, and the second could operate when the store is full, forcibly clearing down the call. In the latter instance it is necessary to provide for the traffic in the store to be instantly erased so that a new telex call can commence as soon as the radio circuit is ready for service; with a FRXD the tape loop can only be "run-out" at normal speed, taking many minutes to clear and wasting valuable circuit time before a new call can commence on the circuit.

##### *Circuit-Efficiency Control*

Since most telex calls will soon be switched automatically, the use of ARQ radio-telegraph channels is receiving special study. The C.C.I.T.T.\* is currently considering a proposal that circuit efficiency should be used as a criterion of the serviceability of ARQ telex channels.<sup>2</sup> With this arrangement the setting up of the telex call would only be allowed if the radio path was giving a circuit efficiency of, say, at least 75 per cent on the telex channel, and this would help in avoiding the necessity for large capacity storage. The use of such an arbitrary minimum value of circuit efficiency would allow call charging by duration in place of the present method of counting the characters actually transmitted. This is important for both automatic and semi-automatic transit working, and for a manual circuit consisting of a cable link in tandem with an ARQ radio-telegraph link. In fact, other countries are considering the use of electronic stores having capacities less than 4,000 characters, with circuit-efficiency devices to avoid over-running. When a drum is used for storage, however, the 4,000-character store is not much more expensive than, say, one having a capacity of 2,000 characters.

\*C.C.I.T.T.—International Telegraph and Telephone Consultative Committee.

*Variation of Character-Transmission Speed*

The design of the drum store also facilitates the use of input and output character speeds other than 50 bauds, e.g. 45.5, 75 and 100 bauds, for other applications.

*Monitoring Facilities*

The basic reading circuit (see Fig. 3) also permits a sequential, i.e. 50-baud start-stop, output to be provided for monitoring purposes. This facility is convenient for maintenance purposes, for which a lamp display of the elements of the input and output characters is also useful.

*Possible Further Development in Circuit Control*

A device has been proposed<sup>7</sup> which uses character No. 32 of the International Alphabet No. 2 as an indica-

tion to a telex subscriber of the conditions of storage on a radio telex unit. However, for this signal to be received, the subscriber must suspend transmission for a period of 10 seconds during normal sending. Since, on radio calls, charging is, at present, based on the actual characters transmitted plus the idle time while the call is still held, the "suspend" period of 10 seconds may add chargeable time to the call. The use of drum-storage techniques offers the possibility of returning to the caller a signal sequence indicating the amount of traffic in store. It is envisaged that these signals might be returned in response to a sequence of prescribed interrogation characters transmitted by the subscriber.

**MECHANICAL CONSTRUCTION**

The prototype equipment comprised three small racks, but production equipment (see Fig. 5) containing six channel stores is mounted on two 7 ft 6 in. racks with

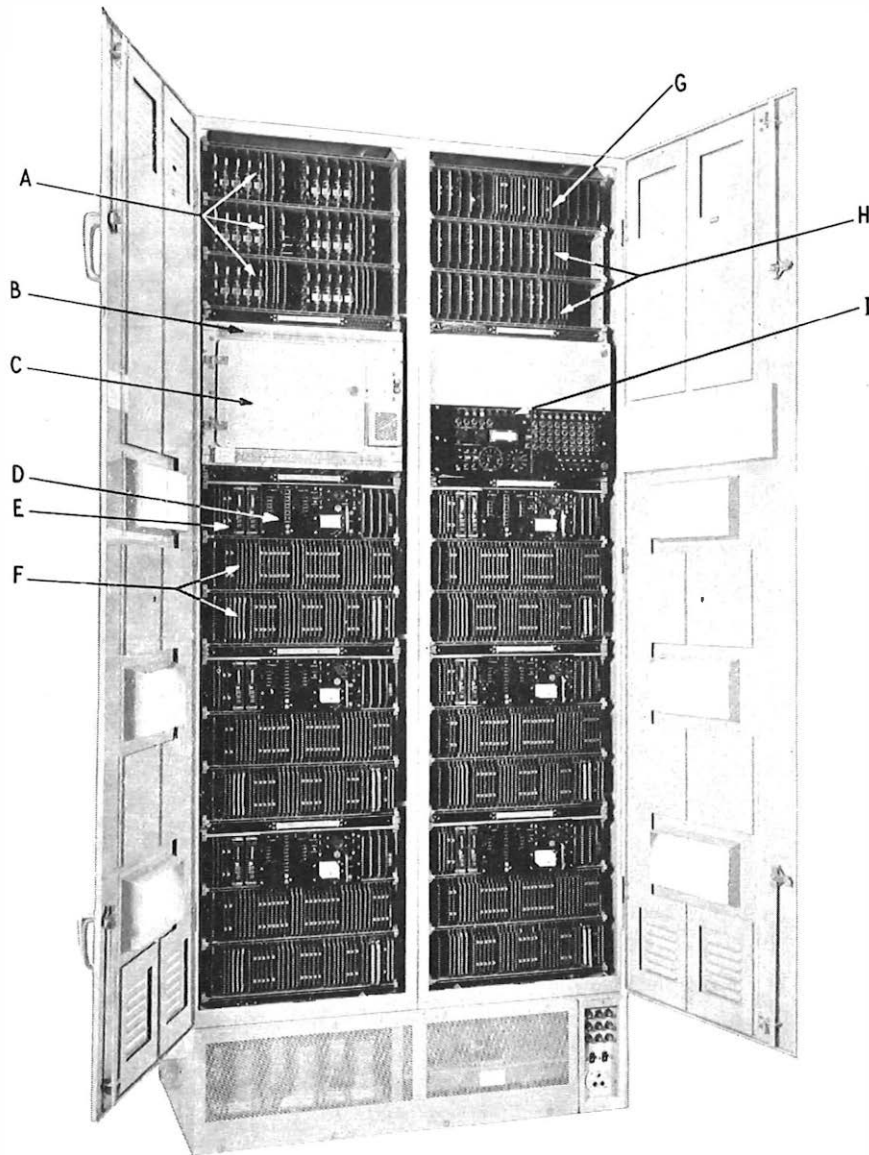

A—Writing circuits. B—Drum-unit wiring field  
 C—Drum unit. D—Channel supervisory unit  
 E—Channel input and output circuits

F—Channel logic circuits  
 G—Miscellaneous common equipment  
 H—Reading circuits. I—Main control and supervisory unit

FIG. 5—ELECTRONIC TELEGRAPH BUFFER STORE

two doors at the front. All indicator lamps, etc., can be seen through cut-outs in these doors. All components and printed circuits are accessible from the front, but access at the rear is necessary if any subsequent wiring changes are required.

#### ELECTRONIC INTERFACE SIGNALS

The term "interface" is now used to denote the inter-connexion circuits between two equipments. The use of transistors requires that the signal level be low, and for telegraph equipment a standard of  $\pm 6$  volts in place of  $\pm 80$  volts has been adopted for use between equipments in, say, the same room. The use of  $\pm 6$ -volt signals only applies where the two equipments are within about 50 feet of each other, or where special cable runs can be provided to segregate  $\pm 6$ -volt circuits from the  $\pm 80$ -volt circuits. Some ARQ equipment already permits operation at  $\pm 6$  volts as an alternative to the old telegraph signalling voltages so that, by the adoption of this  $\pm 6$ -volt interface between the store and the ARQ equipment, all telegraph relays have been eliminated in the buffer store, except for the monitor sequential output.

#### TESTING THE PROTOTYPE STORE

The prototype equipment met the specified performance tests, and after a reliability run of 4 weeks was installed for field trial in the overseas telegraph terminal at Electra House, London.

After initial inductive-interference troubles in Electra House had been overcome, the prototype drum store gave satisfactory results during 6 weeks' continuous use on ARQ radio-telegraph circuits to Buenos Aires and to Rio de Janeiro. During this period there was only one fault; this was caused by a piece of solder lodging across two tags during the wiring changes made to clear the interference troubles.

The percentage-occupancy indication was set to give a chart record of occasions when 50–60 per cent of the capacity of each store was occupied. The chart showed that on only six occasions in 6 weeks operation of six stores was 60 per cent occupancy of the stores exceeded. No operating difficulties occurred.

#### CONCLUSIONS

An electronic buffer store to replace the FRXD has been satisfactorily tested. The limit set for the storage capacity—4,000 characters—influenced to a considerable extent the type of store used and is obviously a compromise. However, the test showed that, providing a radio circuit of an adequate standard of efficiency is available—and such a standard is necessary for operational reasons—the capacity will be satisfactory except in very rare instances, when in fact the use of a FRXD might also cause trouble.

The capital cost of the magnetic store is higher than that of the FRXD, but the economy in operation, due to saving the cost of paper tape and to reduced maintenance, is considered to justify the additional initial outlay; the magnetic store also offers some advantages in use. Production equipment for installation with ARQ equipment in Fleet Building, London, has been manufactured.

#### ACKNOWLEDGEMENT

The authors wish to thank members of the development team of British Telecommunications Research, Ltd., for assistance in producing this article.

#### References

- <sup>1</sup>CROISDALE, A. C. Teleprinting over Long-Distance Radio Links. *P.O.E.E.J.*, Vol. 51, pp. 88 and 219, July and Oct. 1958.
- <sup>2</sup>CROISDALE, A. C., and HARRISON, A. F. Testing Radio-Telegraph Automatic Error-Correcting Equipment. *P.O.E.E.J.*, Vol. 54, p. 245, Jan. 1962.
- <sup>3</sup>CLARK, T. H. A Telegraph Signal Buffer Store. *A.T.E. Journal*, Vol. 12, p. 107, Apr. 1956.
- <sup>4</sup>BEAUFOY, R. Transistor Switching Circuit Design. *A.T.E. Journal*, Vol. 16, p. 141, Oct. 1960.
- <sup>5</sup>MAY, C. A. New Methods of Meter-Pulse Registration. *P.O.E.E.J.*, Vol. 54, p. 168, Oct. 1961.
- <sup>6</sup>CLARK, T. H., THOMSON, I. S., and PRICE, C. K. A Magnetic-Drum-Type Automatic Traffic Equipment with Transistor Switching Elements. *P.O.E.E.J.*, Vol. 53, p. 50, Apr. 1960.
- <sup>7</sup>Recommendation U22, Red Book, Documents of the International Telegraph and Telephone Consultative Committee, Vol. VII, Mar. 1961.

## Book Review

"Television Receiver Servicing," Vol. 2: Receiver and Power Supply Circuits. 2nd Edition. E. A. W. Spreadbury, M.Brit.I.R.E. Iliffe Books, Ltd. vii + 475 pp. 274 ill. 35s.

This is the second edition of Volume 2 of Mr. Spreadbury's comprehensive manual on television-receiver servicing. In reviewing Volume 1 (*P.O.E.E.J.*, Vol. 55, p. 62, Apr. 1962), which dealt with time-base circuits, it was remarked that there had been surprisingly little change in basic circuit design in the eight years since the first edition was published. The same appears to be true of the receiver and power supply circuitry, for practically all the contents of the 1955 edition are repeated in this new one. There are, however, some significant additions.

The first of these deals with multi-channel tuners, the need for which was only just beginning to be felt in 1955. Nowadays, virtually all receivers are switchable to several channels, and it is not surprising that some 30 pages of the book are devoted to descriptions of modern tuners of all kinds. There is the Philips tuner with its printed-circuit "biscuits," the Pye incremental tuner of small dimensions and the American "Fireball" tuner which occupies even less space. There are press-button tuners, remote-

controlled motor-driven tuners and even, looking into the future, a u.h.f. tuner.

A completely new chapter deals with combined television and f.m. sound receivers which have become commonplace in the past few years, and a much expanded chapter on vision a.g.c. indicates another trend in modern receivers. The chapter on aerials and feeders has also been lengthened considerably to cover some of the curiously-shaped devices now so familiar on the roof-tops. A section of this chapter deals with communal aerials for use in blocks of flats as well as for signal distribution over rather wider areas. Another new chapter deals with printed circuits and gives very useful hints on their servicing, a subject which has introduced many new problems.

The final chapter is entitled "The Effect of 625-line Operation" and, after a brief discussion of the parameters that might be adopted, it is concluded that "although a future system of television transmission might be adopted that is different in every parameter from the one we are used to, it would make little difference to the principles of servicing."

Although written primarily for the professional service engineer this book will prove invaluable to the well-informed amateur.

T. K.

*I.P.O.E.E. Library* No. 2321.

# Outline of Transistor Characteristics and Applications

## Part 3—Application of Non-Linear Characteristics

J. A. T. FRENCH, B.Sc.(Eng.), A.M.I.E.E., D. J. HARDING, B.Sc.(Eng.), A.M.I.E.E.,  
and J. R. JARVIS, B.Sc. (Eng.), A.M.I.E.E.†

U.D.C. 621.382.3.012

Part 1 in this series of three articles described types of transistors and their characteristics, and Part 2 showed how the linear characteristics of transistors are used in the design of amplifiers, oscillators and voltage regulators. Part 3 describes the operation of transistors in the regions where the characteristics are non-linear and gives as examples some practical aspects of the design of logic circuits, modulators, toggles and other well-known switching circuits.

### INTRODUCTION

If a load line is drawn on the static output characteristic curve of a transistor, as in Fig. 5 of Part 1,<sup>1</sup> it will pass through the following regions:

1. The transistor is off, i.e. the emitter-base junction is reverse-biased and only leakage current flows in the collector circuit.

2. The transistor is active, i.e. operating on the linear portion of the characteristic curve.

3. The transistor is saturated, i.e. a very small voltage exists between the emitter and collector, and both the collector-base and the base-emitter diodes are forward-biased.

An essential feature of transistor switching circuits is that the transistor may operate in one or other of two stable states, and that these states may be easily identified. In one method of operation the transistor is switched from region 1 (off state) to region 3 (on state) by applying a sufficiently large input signal to ensure that the transistor does not operate within region 2. This method is referred to as voltage switching and is comparable with the use of a simple single-pole on/off switch. The transistor is a fairly efficient switch having a leakage current of less than  $10^{-6}$  amp when it is in the off state and a potential difference across the collector-emitter junction of about 0.5 volts when it is in the on state. Thus, in neither state is the transistor called upon to dissipate any appreciable power. The value of the small potential which exists between the emitter and collector when saturated and also the speed with which the transistor returns to the off state after having been saturated depends on the type of transistor. In another method of operation one of the stable states (the on state) is with the transistor collector current defined within region 2, and the other stable state is in region 1. Usually two transistors or one transistor and a diode are used in this type of switch, and the defined current is transferred from one transistor to the other or from the transistor to the diode.

From these two simple switches a whole range of circuits based upon the non-linear characteristics of transistors may be developed.

### LOGIC CIRCUITS

Logic circuits are used extensively in computers to perform simple arithmetical operations and also to control the order in which these operations are executed. They are also used in the control equipment of electronic tele-

phone exchanges, for example, to perform a register function. Although these logical functions may sound complicated when viewed as a whole, they can all be broken down to three simple elements: the OR gate, the AND gate, and the inverting amplifier. The symbols used to denote these elements are as shown in Fig. 29, the lower symbol being the preferred form.

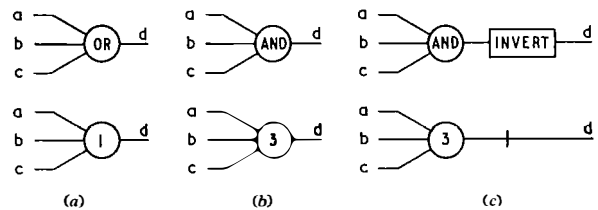

(a) OR Gate  
(b) AND Gate  
(c) AND Gate Followed by Inverter  
FIG. 29—LOGIC SYMBOLS

In switching circuits there are but two states which are of interest: on or off, signal or no signal. The OR gate will give a signal on its output connexion d when a signal is applied to input a, or input b, or input c. It will in fact produce an output if one, two or three input signals are present simultaneously, but the essential feature is that an output signal is produced if one input signal is present, and it is this "1" which features in the symbol. The AND gate gives a signal on its output d when a signal is present on input connexions a and b and c, i.e. all three input signals must be simultaneously present before an output signal is produced. Three input connexions have been shown by way of example, but there is no theoretical limit to the number of inputs although there may be a practical one related to the increased loading of many inputs. The inverting amplifier changes the state of the signal applied to its input, i.e. if the input state is on then the output will be off. The inverter may be combined with either of the gates as shown in Fig. 29 (c). Here a signal on all three inputs results in no signal on output d and no signal on the inputs results in a signal on output d.

### Direct-Coupled Transistor Logic

The circuit diagram of a typical building brick using direct-coupled transistor logic (d.c.t.l.) is shown in Fig. 30. Here three transistors are connected with all emitters

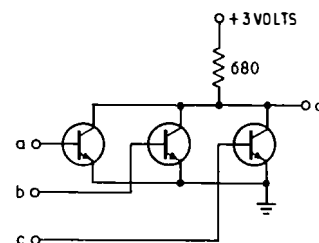

FIG. 30—DIRECT-COUPLED TRANSISTOR LOGIC

†Post Office Research Station.



earthed, and all collector electrodes in parallel to form a 3-input gate. Because the inputs are connected to the base electrodes and the output to the collectors, signal inversion takes place and this circuit is the electrical equivalent of the logical symbol shown in Fig. 29 (c). The operation of this circuit can be explained by considering three directly-coupled stages in cascade as shown in Fig. 31.

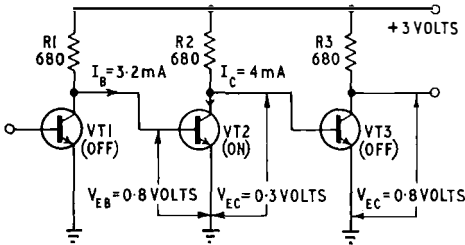

FIG. 31—OPERATING CONDITIONS OF DIRECT-COUPLED TRANSISTOR LOGIC

Assume that transistor VT1 is off, so that the current in resistor R1 flows into the base electrode of transistor VT2 and causes this transistor to saturate. If all three transistors are of silicon n-p-n planar construction employing an epitaxial layer to reduce the saturation voltage, typical electrode voltages for the conducting transistor will be +0.8 volts for base-emitter and +0.3 volts for collector-emitter.

Because the output voltage (+0.3 volts) is less than the voltage required to turn on a similar transistor it follows that transistor VT3 will be off when transistor VT2 is on. Returning now to Fig. 30 it will be seen that the output potential of connexion d will be +0.3 volts if one or more of the transistors conduct, and that the output potential cannot rise so as to render the following stage conducting unless all three transistors are off. Thus, if the logic signal be regarded as the low-potential state (+0.3 volts) and the no-signal state as the high potential state (+0.8 volts) then this building block behaves as an AND gate followed by an inverter. If the logic signal is regarded as the high-potential state then the element can be considered as an OR gate followed by an inverter. This type of logic has the disadvantage that when the inputs of two or more building blocks are connected in parallel, the degree of saturation will vary between the transistors and may be inadequate in some. The situation may be improved considerably by adding a resistance of about 600–800 ohms in series with each base electrode, and with this modification the logic system is usually referred to as modified d.c.t.l. Modern constructional techniques, where all the transistors and resistors in the logic element are made at the same time in one block of silicon, make this form of logic very attractive when compact design and moderate operating speeds (e.g. 0.1 μs average delay per stage) are required. It does demand, however, that the saturation potential of the transistors be tightly controlled so as to achieve a reasonable margin between the on state and the off state.

#### Transistor-Diode Logic

The circuit of one form of transistor-diode logic, where four inputs a, b, c and d are isolated one from another by high-speed diodes, is shown in Fig. 32. No load resistor is shown in the collector circuit of the transistor because this stage would normally be connected to one

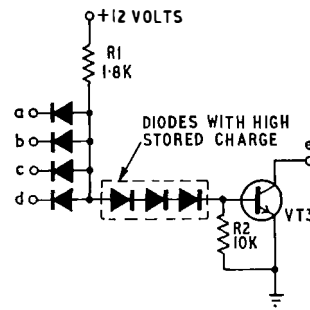

FIG. 32—TRANSISTOR-DIODE LOGIC

or more inputs of other similar stages which provide the required collector current. In Fig. 33 the circuit has been redrawn to show the operating conditions and some

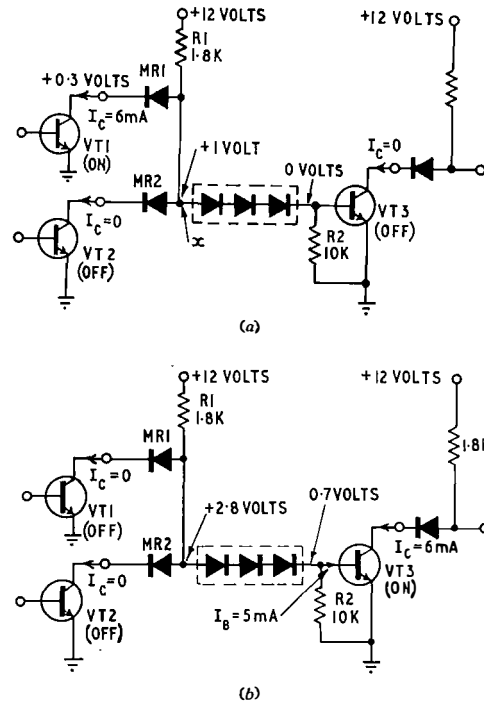

FIG. 33—OPERATING CONDITIONS OF TRANSISTOR-DIODE LOGIC

of the circuit which surrounds the logic block, but only two inputs are shown for simplicity. If it is assumed that transistor VT1 is on and transistor VT2 is off, as in Fig. 33 (a), a current of about 6 mA flows via diode MR1, which is forward-biased, into the collector electrode of transistor VT1. When saturated the potential across this type of transistor is about +0.3 volts and the forward potential drop of diode MR1 is about 0.7 volts, so that the potential at point x is about +1 volt. No current flows in diode MR2 because transistor VT2 is off. The base potential of transistor VT3 is held at 0 volts by resistor R2, and the potential difference across the three series diodes is about 1 volt which is not sufficient to cause them to conduct (about 2.1 volts are required before they conduct). Transistor VT3 is therefore held in the off state. In Fig. 33 (b) both transistors VT1 and VT2 are assumed to be in the off state so that current will flow via resistor R1 and the three series diodes into the base electrode of transistor VT3 causing it to saturate, i.e. VT3 is held in the on state.

It is interesting to consider the various combinations of input conditions and the resulting output states, but in general this logic circuit can be regarded as an OR gate followed by an inverter if the input signal is represented by a switched-on transistor and as an AND gate followed by an inverter if the input signal is represented by a switched-off transistor.

The transition of transistor VT3 from the off state to the on state can take place very quickly because a base current of about 5 mA is available to switch the transistor. In the reverse direction rapid switching takes place because the three series diodes hold a considerable stored charge which quickly removes the base charge from transistor VT3. A large-capacity stored-charge diode may be regarded as a normal diode with a small capacitor in parallel, and in this logic circuit such a capacitor can be regarded as a speed-up capacitor. Three diodes are used to make the circuit less dependent upon (a) spurious signals in the earth circuits, and (b) transistor saturation potential. The immunity to spurious signals in the earth circuits can be further improved by increasing the value of resistor R2 and returning it to a negative potential instead of earth. This type of logic is extremely fast, and a delay per stage of 10 ns ( $10^{-8}$  seconds) is typical.

With the circuit values as shown in Fig. 32, each stage is capable of driving four similar stages. This is usually known as having a fan-out of 4, and in a similar manner the stage has a maximum fan-in of 4.

### Toggle

A toggle is a trigger circuit which has two stable states and which requires an input signal to cause a transition from one state to the other. In general, the circuit has two output connexions and two input connexions, and successive changes of state may be caused by applying a signal first to one input and then to the other. The toggle is used extensively in logic circuits to provide storage functions because an input signal of very short duration will set the toggle, and it will remain set until a signal on the other input resets it. When the toggle is used as part of a system of logic it is highly desirable for the input and output conditions to be such that they may be freely interconnected with logic gates and with other toggles. In this way a fairly complicated system of logic may be planned on a logic diagram with the confidence that when the circuits are put together satisfactory operation will result.

The circuit of a toggle can be developed from the circuit of a gate, such as the one shown in Fig. 32, by cross-connecting two of these gates so that the output of the first is connected to the input of the second and the output of the second to the input of the first, as shown, with its logical symbol, in Fig. 34. It is worth noting the convention that if a given state is applied to input A then the same state is produced at output C. Assume that input A is connected to a switched-on transistor (not shown); current will flow via resistor R1 and diode MR1 to this transistor. The base electrode of transistor VT1 will return to earth potential and no current will flow via diode MR4 and transistor VT1. Instead, a current will flow via resistor R3 and diodes MR8-10 into the base of transistor VT2 switching this transistor on. Transistor VT1 is now off and transistor VT2 is on. The states of both transistors will change over if input B, in place of input A, is connected to an on transistor.

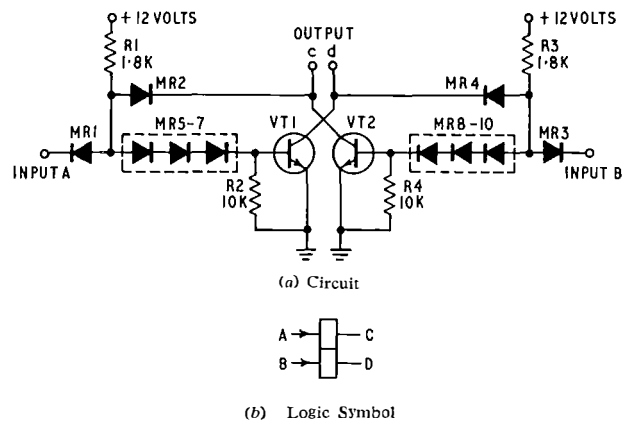

FIG. 34—TOGGLE CIRCUIT

### SWITCHING SQUARE-LOOP MAGNETIC CORES

Square-loop magnetic cores may be magnetized in one or other of two states by a current of several hundreds of milliamperes flowing in a wire which threads the cores. When these cores are used as a memory, i.e. as a store, it is economic to arrange them in the form of a matrix; for example, a  $64 \times 64$  matrix stores 4,096 bits of information. A transistor is used to switch the current in a wire which threads many cores. The organization of the store may not require all cores threaded by a particular wire to switch, but every core will contribute to the back e.m.f. which opposes the switching current. In a large store, where for example 1,000 cores may be threaded by one wire, this back e.m.f. may be about 10 volts and this will influence the choice of transistor switch used to drive the store.

Fig. 35 shows the circuits of the two basic transistor

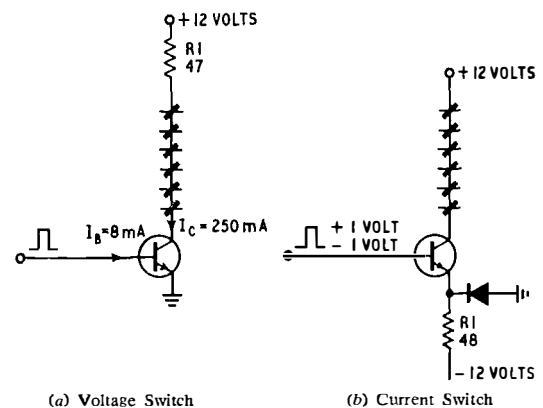

FIG. 35—SWITCHING SQUARE-LOOP MAGNETIC CORES

switches used to drive magnetic-core stores. The transistor can be used as a voltage switch or as a current switch. When used as a voltage switch the transistor is either in the non-conducting state or in the saturated state, and as very little power is dissipated within the transistor in either state no special measures need be taken to remove the heat produced. The magnitude of the current is determined by the supply voltage less the saturation voltage between emitter and collector and by the series resistance in the collector circuit. Any back e.m.f. induced in the collector circuit will oppose the growth of current, and the time taken for the current to

reach its final value will depend upon the number of cores threaded by the circuit, i.e. the turn-on time increases as the number of cores is increased. The operation of this circuit is considerably improved by making the voltage of the supply as high as possible so that resistor R1 (Fig. 35 (a)) may be increased in value, and in this way the current is less dependent upon the back e.m.f. from the cores.

By using the transistor as a current switch so that the transistor is in its active region while the current is flowing in the wire threading the cores, advantage is taken of the effective high-impedance source presented by the collector circuit. The transistor behaves as a constant-current generator, i.e. the current is not modified by the back e.m.f. from the cores as long as the transistor is in the active region of its characteristic.

When the base potential is at  $-1$  volt, current will flow via the diode and resistor R1 (Fig. 35 (b)) to the negative supply, and the forward potential drop across the diode will be about 0.8 volts. Thus the base-emitter junction of the transistor is reverse-biased and the transistor is in the off region. When the base electrode is pulsed to a potential of  $+1$  volt the transistor is taken into the active region and the emitter potential is raised to about  $+0.2$  volts so that the diode is now reverse-biased. The emitter current is now fixed by the value of resistor R1 and the potential difference across it. Because the transistor is now in the active region it may be required to dissipate several watts, but the mean power dissipated will of course depend upon the duty cycle.

#### CURRENT-CONTROLLED TIME-DIVISION MULTIPLEX

In an electronic telephone exchange using time-division multiplex (t.d.m.) switching, one pair of wires can carry many separate telephone circuits. Each circuit uses a separate train of regularly recurring pulses, the amplitude of which is modulated by the speech signal. The pulse trains relating to the various t.d.m. channels are interleaved in time so any one channel does not overlap another. The modulator circuit used in a current-controlled t.d.m. exchange, as shown in Fig. 36, is a good example of a transistor used as a current-controlled switch.

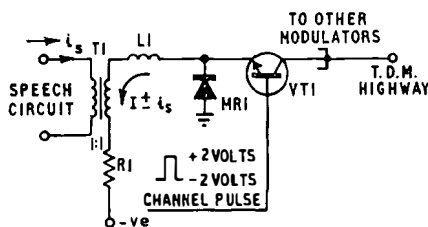

FIG. 36—CURRENT-CONTROLLED MODULATOR

In the absence of a channel pulse the base electrode of transistor VT1 rests at a potential of about  $-2$  volts. A current  $I \pm i_s$  flows from earth via components MR1, L1, T1 and R1 to the negative supply and produces a forward potential drop of about 0.7 volts across diode MR1. The base-emitter junction of transistor VT1 is thus reverse-biased so that this modulator is effectively disconnected from the t.d.m. highway. When the channel pulse is present the base of the transistor is raised to a potential of  $+2$  volts so that the transistor conducts and causes diode MR1 to become reverse-biased. Because the inductor L1 is included in the circuit, the cur-

rent which was flowing in diode MR1 now flows in transistor VT1. The potential of the highway is such that transistor VT1 is operated in its active region so that there is a linear relationship between current in the secondary winding of transformer T1 and the current magnitude of the pulse on the t.d.m. highway. The pulse current is composed of two parts: (a) the steady value when no speech is present, known as the pedestal current, and (b) the varying part related to the speech current. The relative magnitude of these must be such that the instantaneous pulse current does not fall below about, say, 20 per cent of the pedestal current.

#### SWITCHING SPEED

A transistor current switch may be considered as a common-base amplifier having a step of current applied to the emitter electrode. The resulting collector current will exhibit a time constant,  $T = 1/2\pi f_\alpha$ , where  $f_\alpha$  is the alpha cut-off frequency of the transistor. For example, a transistor having  $f_\alpha = 5$  Mc/s would have a time constant of  $0.032 \times 10^{-6}$ . It must be stressed that this relationship only holds if the transistor is not driven into saturation. If a current step is applied to the base electrode of the same transistor connected as a common-emitter amplifier, so that advantage may be taken of the current gain of this arrangement, the time taken to turn on the collector current is increased in proportion to the ratio of collector current turned on to base current supplied. If this ratio is 50, the time constant is increased from  $0.032 \times 10^{-6}$  to  $1.6 \times 10^{-6}$ . This is because the same charge has to be supplied to the base of the transistor to switch a given current in both configurations, and in the common-emitter amplifier the small base current takes longer to supply the required charge.

The circuit shown in Fig. 37 illustrates how a speed-up capacitor, C1, may be added in parallel with a

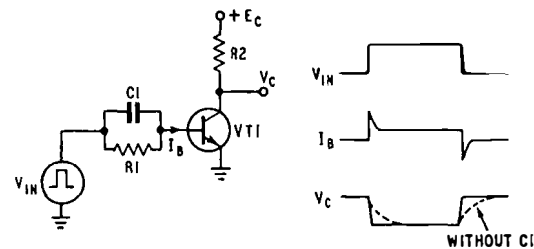

FIG. 37—USE OF SPEED-UP CAPACITOR

resistor connected between the base of a transistor and a pulse source so that the charging and discharging currents of the capacitor provide the current necessary to turn the transistor on and off. The resistor R1 provides the steady base current required to maintain the collector current while the transistor is on and it provides the d.c. path to hold the transistor in this state.

If the value of resistor R1 is reduced so that the base current is greater than that required to maintain the collector current, the transistor will saturate. Additional charge will have to be supplied to the base in order to switch the transistor off. The amount of extra charge depends upon the value of excess base current and a transistor parameter known as the hole-storage time constant.

The concept of a transistor being controlled by a charge applied to the base has been developed mathe-

matically<sup>2</sup> and provides an accurate method of calculating the turn-on and turn-off times of alloy junction transistors, but although the same general principles apply to transistors made by a diffusion process the results are much less accurate.

### Anti-Saturation Circuits

A saturated transistor is more difficult to switch off than a non-saturated one, and therefore precautions are sometimes taken to ensure that the transistor cannot be driven to saturation even though excess drive is applied to the base. Two typical circuits designed to prevent saturation are shown in Fig. 38. Both operate by en-

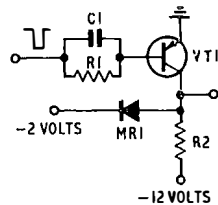

(a) Diode Clamp

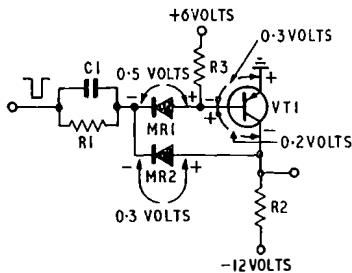

(b) Low-Dissipation Clamp

FIG. 38—ANTI-SATURATION CIRCUITS

sure that the base-collector junction is always reverse-biased. In Fig. 38 (a) the additional collector current demanded by the excess base drive causes diode MR1 to conduct and so clamp the collector potential at about 1.5 volts. However, this circuit increases the power required to be dissipated by the transistor. The second circuit (Fig. 38 (b)) prevents saturation without increasing the power dissipated in the transistor. Resistor R3 is included to provide bias to maintain transistor VT1 in a non-conducting state in the absence of the input signal. The operation of this circuit depends upon MR1 being a silicon diode and MR2 being a germanium diode, the forward potential drops being 0.5 volts and 0.3 volts, respectively. Assume transistor VT1 is conducting and that it is a germanium transistor, the potential of the base electrode will then be -0.3 volts. Both diodes MR1 and MR2 are forward-biased: MR1 by virtue of the current in resistor R3 together with the base current, and MR2 by current provided by the input pulse. Because of the difference between the forward potential drops of the silicon and germanium diodes the collector will be held 0.2 volts negative relative to the base, i.e. the transistor is not saturated.

One variation of the circuit of Fig 38 (b) which is sometimes used, eliminates diode MR1 and substitutes the parallel combination of resistor R1 and capacitor C1. The potential difference across resistor R1 due to the flow of the base current replaces the forward potential drop across diode MR1, but the proportioning of the

component values in this arrangement is somewhat more critical than in the circuit of Fig. 38 (b).

### OPERATION OF A RELAY BY A TRANSISTOR

Transistor circuits are frequently required to operate normal Post Office type relays, for example in a v.f. signalling receiver. The circuit of Fig. 39 shows how

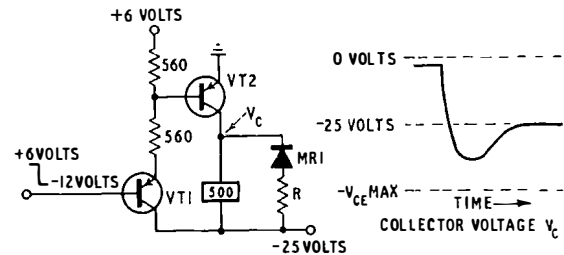

FIG. 39—OPERATION OF RELAY BY A TRANSISTOR

two transistors may be used to operate a relay from an emitter follower so that advantage may be taken of (a) the high current gain of this configuration, and (b) the low output impedance which provides a suitable source for the base circuit of transistor VT2. When the input signal is applied, transistor VT2 quickly saturates and the collector current then builds up to 50 mA. The rate of current increase is determined by the time constant  $L/R$ , and the relay will operate at some point on this curve. When the input signal terminates a reverse bias is applied to the base-emitter junction of transistor VT2 and the collector current is reduced. Because of the inductance of the relay, a large back e.m.f. will develop across its winding. This back e.m.f. could cause an excessive voltage to exist between the collector and emitter electrodes of transistor VT2 and, if it were not restricted in magnitude by the diode MR1 and resistor R, it is possible that the transistor would be damaged.<sup>3</sup> The presence of diode MR1 will have the effect of making the relay slow to release, and it is necessary to so proportion the value of resistor R, the supply voltage and the breakdown voltage that an acceptable speed of operation is obtained. In general, reliable operation will be obtained if the supply voltage is less than  $V_{CE(MAX)}$  at the chosen operate current for the relay and if the resistor R is of low value. Frequently, it will be found possible to dispense with a resistor in series with the diode when a low-current relay is used, and resistance may be added in series with the relay coil to determine the current.

### COMPLEMENTARY TRANSISTOR CIRCUITS

The existence of two types of transistor, n-p-n and p-n-p, has already been mentioned in the first part of this series, and in many applications it is immaterial which is employed. For pulse-type applications one type is usually more suitable than the other, depending

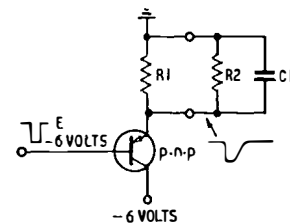

FIG. 40—P-N-P EMITTER FOLLOWER

upon the polarity of the pulse. For example, in the emitter-follower circuit of Fig. 40, a p-n-p transistor is selected because the leading edge of the negative-going input pulse causes the transistor to conduct and the element provides a low output impedance so that a capacitive load may be charged quickly. When the input pulse starts to return to earth potential it does so more rapidly than the output potential can change, with the result that the base-emitter junction is reverse-biased for a short time. The low impedance provided by the emitter-follower connexion is absent, and the output potential will return to earth at a rate depending upon the time constant of resistors R1 and R2 and capacitor C1. If the same input signal were applied to a similar circuit using a n-p-n transistor in place of the p-n-p transistor, the leading edge of the input voltage wave would change slowly and the trailing edge rapidly, i.e. the opposite of the p-n-p case. It is a simple matter to interconnect these two circuits so that both the leading and trailing edges of the output wave change rapidly. Fig. 41 shows the circuit of a typical complementary emitter follower.

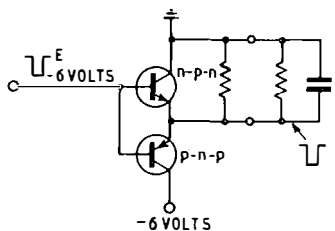

FIG. 41—COMPLEMENTARY EMITTER FOLLOWER

#### PULSE GENERATION

In most transistor switching circuits the input signal is required to have a rectangular waveshape so that the duration of the on and off state may be clearly defined in time. In many applications, the basic timing of all switching operations is derived from a sine-wave master oscillator having a high order of frequency stability, for example, a crystal or LC oscillator as shown in Fig. 25 of Part 2<sup>4</sup> of this series. Such an oscillator could provide the input signal for the pulse-forming circuit shown in Fig. 42.

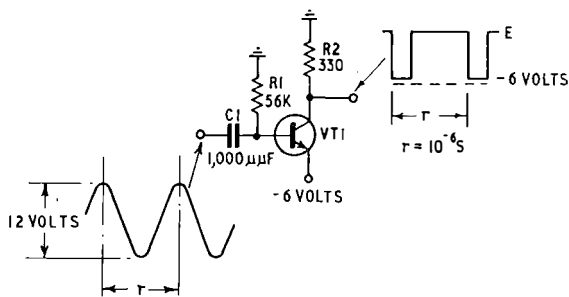

FIG. 42—SIMPLE PULSE-FORMING CIRCUIT

A sine wave of peak-to-peak amplitude about 12 volts and frequency about 1 Mc/s is coupled by capacitor C1 to the base electrode of the common-emitter transistor VT1. The base-emitter junction of transistor VT1 will cause the capacitor C1 to be charged by the positive-going part of the input signal. The polarity of this charge is such that it tends to bias the transistor towards the cut-off state. Resistor R1 will discharge capacitor C1, and a state of equilibrium will exist such that the

amount of charge required every cycle can be supplied by a current flowing for only a small part of the cycle, i.e. the positive tips of the incoming sine wave. This charging current turns on the transistor and produces rectangular pulses of current in the collector circuit. By choice of suitable values for resistor R1 and capacitor C1 it is possible to select a range of mark/space ratios for the output wave. In the example given the transistor is subjected to a reverse base-emitter potential of about 12 volts; not all types of transistors will withstand this order of potential and, in particular, many of the diffused types of transistor have a  $V_{EBM}$  of about 6 volts. However, this circuit works well using an alloy junction type of transistor which will withstand, in general, a greater reverse base-emitter potential than those of the diffused type.

#### TRANSISTOR INVERTERS AND CONVERTERS

The production of relatively high a.c. or d.c. voltages when only low-voltage d.c. sources were available was once possible only by using rotating machines or vibrators. Now, transistor oscillator circuits can produce quite high powers at an efficiency of 75–80 per cent which makes them attractive for inverter purposes. Fig. 43 shows a simple push-pull class-C oscillator which operates in a manner similar to that of the oscillator described in Part 2 (Fig. 25) except that the two tran-

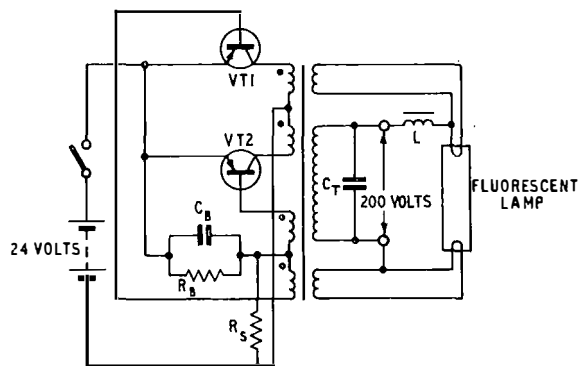

FIG. 43—TRANSISTOR INVERTER

sistors VT1 and VT2 conduct alternately and the tuned-circuit inductor is a transformer which steps up the output voltage to the desired value. For operation of a fluorescent lamp an inverter a.c. output at 200 volts is required, and an operating frequency of 5–10 kc/s enables low-frequency power transistors to be used whilst keeping the size of the transformer, capacitor, and ballast inductor to a minimum. Resistor  $R_s$  provides a small base current to ensure easy starting of the oscillator when switched on, and the much larger base current under running conditions is controlled by resistor  $R_B$ .

By rectifying the a.c. output from a transistor inverter a d.c. to d.c. converter is obtained and may be used to provide one or more either higher or lower d.c. voltages from the d.c. source by using appropriate windings on the transformer.

The inverter circuit described would produce an approximately sinusoidal waveform and would be suitable for use with a rectifier. However, a greater power output and higher efficiency is possible by producing a rectangular waveform because the transistors operate as switches and are either fully on or fully off. Power loss in the transistors during the transitions between on and off are thus reduced to a minimum. A rectangular

waveform could be obtained from Fig. 43 by omitting the tuning capacitor  $C_T$  so that the timing of the tran-

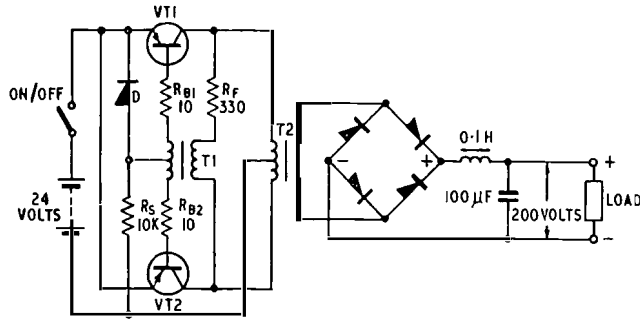

FIG. 44—TRANSISTOR D.C. to D.C. CONVERTER

sitions is determined by saturation of the transformer core causing the collector current to increase. This causes an increase in core loss which is avoided in Fig. 44 by using a separate small transformer, T1, having a saturating core to provide the feedback from the collectors via a resistor,  $R_F$ , to the bases.<sup>5</sup> The transformer T1 determines the times of transitions by reducing the base current rather than by increasing collector current, and so permits the full output power capabilities of the transistors to be used in supplying the load. The maximum output is limited by the peak voltage and current ratings of the transistors rather than by their dissipation which is the sum of the transition loss and the loss due to the voltage-drop in the on state. These losses together with the output transformer and rectifier losses will determine the efficiency, which would normally exceed 80 per cent on full load. Further advantages of the rectangular waveform are that the rectified output is easy to smooth and that a very low output impedance is obtained. An operating frequency of the order of 500–1,000 c/s is used with low-frequency power transistors. Resistor  $R_S$  provides a small base current to ensure easy starting and the diode D then conducts to provide a low-resistance path for the running base current. Resistors  $R_{B1}$  and  $R_{B2}$  are used to reduce the effect of the emitter-base potential differences in the two transistors.

#### CONCLUSIONS

It has not been possible to include all known transistor switching circuits; instead, a few basic circuits have been selected and these have been described in sufficient detail

to enable their essential features to be understood. For example, shift registers and binary counters have not been included because in essence they are but special arrangements of toggles and gates, and as such may be developed from these basic circuits.

It is hoped that sufficient information has been given in this series of three articles to enable the reader to understand the operation of many of the more conventional items of equipment using transistors, and also to be able to incorporate transistors in circuits to his own design. It is important that the manufacturer's rating is not exceeded in any respect and this is particularly so when inductive loads are included in the collector circuit of the transistor. The design of transistor circuits is simplified if a transistor can be chosen so that it is operated well below its cut-off frequency, and is treated as a current-controlled device with due allowance made for its low and variable input impedance.

At the present time it is probably correct to say that germanium-type transistors predominate in Post Office applications of transistors. The following properties of the silicon planar transistor,<sup>6</sup> and in particular the n-p-n version of this transistor, will ensure its widespread application within the Post Office in the future.

(a) They have low leakage current at higher temperatures.

(b) The manufacturing process produces up to a thousand transistors at one time on a single slice of silicon which is subsequently divided, leading to a low price for a high-quality device.

(c) The transistor is protected by a glass-like layer of silicon dioxide, and the junctions are formed beneath this layer, leading to high reliability.

(d) Tests indicate that this type of construction produces a transistor having a long expectation of life.

#### References

- <sup>1</sup>FRENCH, J. A. T., HARDING, D. J., and JARVIS, J. R. Outline of Transistor Characteristics and Applications, Part 1. *P.O.E.E.J.* Vol. 56, p.122, July 1963.
- <sup>2</sup>BEAUFOY, R., and SPARKES, J. J. The Junction Transistor as a Charged-Controlled Device. *A.T.E. Journal*, Vol. 13, p.310, 1957.
- <sup>3</sup>Mullard Reference Manual of Transistor Circuits. p.252 (*Wightman and Co., Ltd.*, 1960).
- <sup>4</sup>FRENCH, J. A. T., HARDING, D. J., and JARVIS, J. R. Outline of Transistor Characteristics and Applications, Part 2. *P.O.E.E.J.*, Vol. 56, p.196, Oct. 1963.
- <sup>5</sup>Mullard Reference Manual of Transistor Circuits, p.281 (*Wightman and Co., Ltd.*, 1960).
- <sup>6</sup>HENDERSON, J. C., and WILSON, Sylvia J. Design and Technology of Silicon Planar Transistors. (In this issue of the *P.O.E.E.J.*)

## Book Review

"International Series of Monographs on Electromagnetic Waves, Electromagnetic Waves in Stratified Media." J. R. Wait, F. Inst. Radio Engrs. Pergamon Press, Ltd. viii+372 pp. 82 ill. 100s.

The author is known as an authority on radio-wave propagation, particularly in the field of very low-frequencies which figures prominently in the present volume.

Following an analysis of the reflection of radio waves from stratified and inhomogeneous media, the author deals with the classical problem of propagation along a spherical surface and then with the mode theory of wave propagation with its particular applications to v.l.f. waves. Later interesting chapters compare the results of experiments,

including those of the early radio pioneers, with the mode theory for v.l.f. and extra-low-frequency waves.

It is only in the final chapter that detailed reference is made to propagation at the much higher frequencies of interest to the modern radio engineer. This chapter deals with super-refraction and the theory of tropospheric ducting but the treatment is by no means as extensive as that afforded to propagation at frequencies below 30 kc/s.

The book is highly mathematical and this, together with its particular association with v.l.f. waves, must make it of limited value to the engineer. Nevertheless, to the mathematical physicist working in the field of electromagnetic-wave propagation, it will be of value to have the results of the author's studies presented in this compact form.

J.K.S.J.

# Testing Facilities and Methods for the 405-Line Television Networks

R. GARDINER, Associate I.E.E.†

U.D.C. 621.317.34:621.397.743

The testing facilities and methods that have been developed for the maintenance of the British Post Office 405-line television networks are reviewed. Brief descriptions of certain individual items of equipment are given, together with arrangements of testing equipment to meet the special requirements of the service.

## INTRODUCTION

TEST equipment for the first British Post Office 405-line network, provided to carry the television program of the British Broadcasting Corporation (B.B.C.), was in most instances designed and constructed concurrently with the transmission equipment by the manufacturers of each link. Emphasis was placed upon the measurement of the steady-state characteristics of the channels for the maintenance of their transmission performance. Some waveform measurements were also made, but the results were often controversial owing to the limitations of the available waveform generators and oscilloscopes, which were not of standard designs throughout the network. With the exception of the London terminal at Museum Telephone Exchange, little need arose for any form of centralized control of the testing facilities, and test equipment was generally mounted on racks adjacent to the transmission equipment.

With the provision of the second 405-line network for the Independent Television Authority and its program contractors, the dual responsibility of the Post Office for the interconnexion of channels separately rented by these customers and, later, the rapid rearrangement of the interconnexion (program-switching), made necessary the establishment of network switching centres (N.S.C.s) in the main cities.<sup>1, 2</sup> These factors also resulted in a need for a central video distribution rack (V.D.R.) at each N.S.C. upon which all channels terminate at a standard level (1 volt peak-to-peak) and standard impedance (75 ohms). Separation of the control and maintenance functions of the television N.S.C.s in the larger cities became necessary owing to the increase in the volume of testing to be done, and also because of a reduction of available testing time as the program time and other uses of the channels increased.

The control functions, i.e. initial fault-acceptance, routine end-to-end channel testing, control and monitoring, were covered by the establishment of separate control rooms and central test suites with full facilities for the overall video testing of all channels. Testing facilities required for the maintenance of the transmission equipment, fault location,

†Main Lines Development and Maintenance Branch, E.-in-C.'s Office.

etc., have been provided by the introduction of trolley-mounted test equipment.

## Central Control Rooms

The role of the control room at the major television N.S.C.s has some parallels with that of the trunk test room of the telephony network, in the acceptance of fault reports, rapid identification of the cause of the report and immediate action to restore service.

A standard test console has been designed with layouts to suit various installations. Each installation provides facilities for the application of all the test signals required for the end-to-end testing of any outgoing television channel, and the association of a precision oscilloscope, picture monitor or wideband decibelmeter with any incoming channel. Press-button control of other rack-mounted picture monitors that face the console is also provided, so that they can be connected to any channel for the observation of the service being transmitted.

Other control facilities, such as supervisory signals and the remote control of radio links and video links are also concentrated in the control rooms.

Fig. 1 shows a general view of the present control room at the London television N.S.C. The suite on the



FIG. 1—CONTROL ROOM OF LONDON TELEVISION NETWORK SWITCHING CENTRE

left is the V.D.R., which has to be within easy reach of the staff at the test consoles.

## Smaller Network Switching Centres

A need arose for similar centralized control, testing

and monitoring facilities at smaller N.S.C.s, which normally have a lighter load than such centres as the London N.S.C. The necessary facilities are provided by a suite of 19 in. racks equipped with all necessary test and monitoring equipment and providing space for a smaller form of V.D.R. The precision oscilloscope is not mounted on this suite but is trolley-mounted, so that it fulfils the dual function of a control instrument and maintenance tool for use on equipment racks in the associated repeater station.

#### *Repeater Station Facilities*

As a result of improvements in components and circuit design, trolley-mounting of test equipment has become practicable, and a simple trolley framework has been designed for mounting any standard 19 in. apparatus panel.

To meet the requirements of testing in the repeater stations at main terminals, four standard trolley layouts are used, giving the following facilities:

(i) *Send Trolley*. Sending pulse-and-bar, linearity waveform and sine-wave test signals in outgoing television channels.

(ii) *Receive Trolley*. Picture and waveform display of signals received from incoming television channels; noise measurements.

(iii) *Waveform Trolley*. As (ii) but with the addition of decibelmeter, pulse-and-bar and sine-wave signal generators for sending and loop testing.

(iv) *Steady-State Trolley*. Selective measurements up to 30 Mc/s on vestigial-sideband translating equipment (used on certain inter-city coaxial cable links).

Each trolley is provided with mains-distribution and coaxial-termination panels and a drawer for storage of test cards, probes, oscilloscope cursors, etc., and the standard facilities mentioned above can be varied to meet special requirements.

Fig. 2 shows the waveform test trolley.

#### *Intermediate-Station Testing Facilities on Coaxial Line Links*

Testing equipment and methods used for the maintenance of intermediate stations on the main television coaxial-cable links are basically similar to those used on the telephony systems but with the addition of a number of specially-designed items, such as a portable wideband decibelmeter.

With the introduction of inter-supergroup measuring equipment on the coaxial-cable telephony systems the opportunity was taken to change the maintenance practice for television line systems. New test equipment was designed to provide accurate means of measuring the response of the telephony links at certain fixed frequencies between the supergroups, without the removal of the system from traffic. Inter-supergroup-frequency testing has also been adopted for the television line systems, so that maintenance practice is common to both television and telephony systems, but in-service testing is not possible on television links.

#### *Radio Systems*

New radio systems are not provided with built-in video test equipment, but the standard items are used at terminal and intermediate stations. Modified versions of the standard trolley layouts are employed, and the

trolley-mounted precision oscilloscope is the standard instrument for overall waveform testing.

#### VIDEO TESTING EQUIPMENT AND METHODS

Standard items of test equipment are now in use to measure and observe the transmission characteristics of the channels in the Post Office television networks. Some of the test equipment and methods of use are described below.

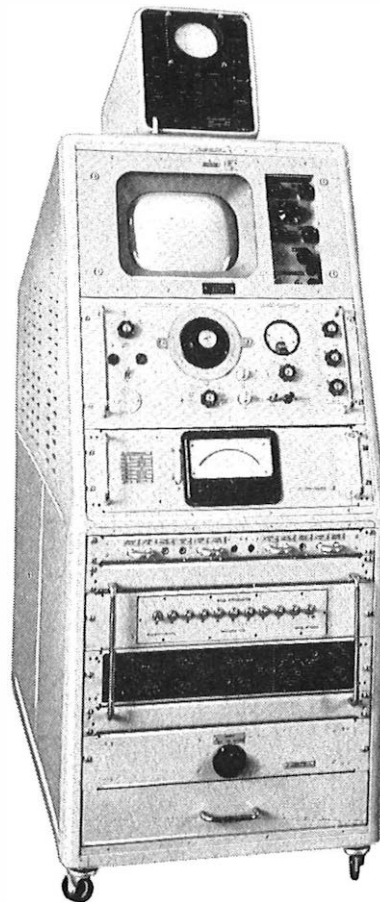

FIG. 2—WAVEFORM TEST TROLLEY

#### *Waveform Distortion Measurements*

By 1954 proposals were published<sup>3</sup> for the assessment of the linear-waveform performance of television links. An earlier paper<sup>4</sup> detailed the practical mathematical process whereby the absolute performance of a link, i.e. the exclusion of the distortion due to the test equipment and of irrelevant information outside the wanted frequency band, could be determined. An explanation of the interpretation of various forms of waveform distortion and the method of measurement and correction of these distortions has been given in a previous article in this journal.<sup>5</sup> These theoretical advances were followed by the design of a stable pulse-and-bar waveform generator and a precision oscilloscope with which the proposals could be implemented.

#### *Pulse-and-Bar Waveform Generator*

The pulse-and-bar waveform generator (Generator, Waveform, No. 2A) gives an output consisting of a half-line-width bar (40  $\mu$ s) of peak-white amplitude and a sine-squared pulse of the same amplitude, super-



imposed on line synchronizing pulses, having a repetition rate of approximately 10 kc/s, i.e. C.C.I.T.T.\* Test Waveform No. 2 (405-line standards).<sup>6</sup> An important feature of the design is that the waveform is defined by a passive network, i.e. a specially designed low-pass filter, and is largely independent of valve-characteristic changes. Two such filters are available, selected by means of a switch, giving sine-squared pulses that have half-amplitude widths of 0.17  $\mu$ s and 0.33  $\mu$ s and whose energy spectra are shaped to exclude energy above 6 Mc/s and 3 Mc/s, respectively. The pulse-and-bar waveform generator is used for all acceptance tests and routine waveform-response measurements on all 405-line channels.

### Precision Television Oscilloscope

Since the publication of the methods of waveform testing detailed in references 3 and 4 the Post Office has designed a precision oscilloscope for waveform measurements. This oscilloscope (Oscilloscope No. 5A) is now the standard precision oscilloscope (Fig. 3) employed for the maintenance of the television networks; it includes a number of features not present in commercial-oscilloscope designs. The principal feature is the provision of a hum-rejection filter which does not



FIG. 3—PRECISION OSCILLOSCOPE

introduce distortion on waveforms with repetition rates of 10 kc/s and above. A highly-linear triggered time-base with automatic control of the triggering stability ensures jitter-free displays, which are essential for the assessment of channel performance on a waveform basis. Selection of the portion of the waveform to be displayed

\*C.C.I.T.T.—International Telephone and Telegraph Consultative Committee.

is achieved by controlling the delay in the firing of the time base by the triggering pulse, this pulse being developed from the chosen edge of the input waveform. A further special facility is provided in that the time base may be caused to double-scan, i.e. to produce two traces whose triggering points on the input waveform are displaced in time. One trace is triggered from a fixed point, whilst the other is controlled by a variable delay circuit. This enables direct comparison to be made of the amplitudes of two parts of the displayed waveform, i.e. the sine-squared pulse and the bar.

A special camera has been developed for use with the television oscilloscope for photographically recording waveform responses of television links. The camera includes facilities for the identification of the exposures by means of an illuminated numbering device.

### Non-Linearity Measurements

Agreement on the methods of measurement of non-linear distortion of television channels was delayed until 1959, when the Post Office and its customers decided to adopt a standard testing waveform and method of assessment. A suitable waveform generator (Generator, Waveform, No. 5A) has been developed in co-operation with the B.B.C. and is now being introduced for the maintenance of the networks.

The output of the waveform generator consists of a line-synchronizing-pulse waveform with a five-step staircase waveform occurring on every fourth line; the intervening lines can be switched to black or white level as required. At the output of the television channel or equipment under test, the waveform is differentiated, and the resulting voltage spikes from each riser of the staircase are compared in amplitude on an oscilloscope. Bandwidth limiting of the differentiated waveform and amplitude limitation of the unwanted products of differentiation are employed to prevent possible inaccuracies of the result. The linearity of the link under test is expressed as the difference between the amplitudes of the smallest and largest voltage spikes, as a percentage of the largest. The worst of the two measurements made, with the intervening lines switched to black and white, respectively, is quoted as the non-linear distortion of the channel or equipment under test. Fig. 4 shows the items of equipment used at the receive end of the link.

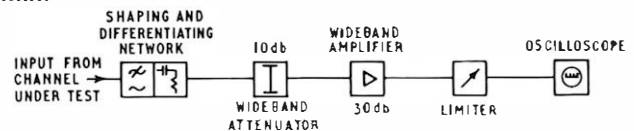

FIG. 4—BLOCK SCHEMATIC DIAGRAM OF CIRCUIT FOR NON-LINEARITY MEASUREMENTS AT RECEIVE END OF CHANNEL

### Noise Measurement and Observation

Three measurements of signal-to-noise ratio are required on television links, as follows.

(i) *Continuous Random Noise.* The signal-to-noise ratio for this measurement is the expression in decibels of the ratio of the peak-to-peak amplitude of the picture signal to the weighted r.m.s. value of the noise. When noise is measured on an oscilloscope as a weighted peak-to-peak value, a crest factor of 18 db is applied to give the corresponding r.m.s. noise value. Hum is excluded, when making random-noise measurements, by use of a high-pass filter, and the upper-frequency limit of the measurement is defined precisely by means of a 3.25 Mc/s low-pass filter.

(ii) *Periodic Noise.* Separate measurements of the signal-to-periodic-noise ratio are required for two frequency bands, each measurement being quoted as the ratio of peak-to-peak picture amplitude to peak-to-peak noise. The two frequency bands are the band containing the hum and its lower-order harmonics, and the band between 1 kc/s and 3 Mc/s.

(iii) *Impulsive Noise.* Measurement of the ratio of the peak-to-peak value of any impulsive type interference to the peak value of the picture signal is required. Impulsive noise is measured directly by the use of a wideband oscilloscope such as the Oscilloscope No. 5A.

A noise-measuring panel was developed to provide a convenient means of introducing the necessary filters and networks for the above measurements of random and periodic noise. The panel provides switching facilities for the insertion of suitable filters and of a weighting network, to facilitate separate measurements of hum and wideband noise. The latter measurement is made via the bandwidth-limiting filter referred to above and may be weighted by a suitable network as required. Fig. 5 shows a block schematic diagram of the noise-measuring panel and associated items of test equipment.

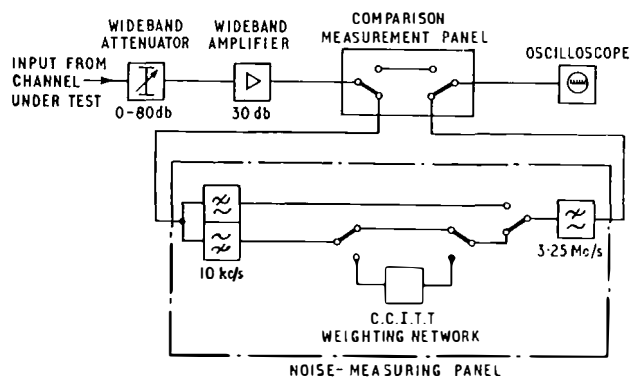

FIG. 5—BLOCK SCHEMATIC DIAGRAM OF NOISE-MEASUREMENT CIRCUIT FOR TELEVISION CHANNELS

Measurement of noise is normally carried out whilst television channels are out of service. Picture monitors are provided for the observation of noise interference, certain picture distortions and continuity during program time, and at present three types of monitor are in general use (Picture Monitors No. 1A, No. 3A and Type 714). The first two were developed from com-

mercial television receivers, the former being a portable type used for outstation maintenance and for outside broadcast circuit provision, whilst the second, with replaceable video amplifier and time-base chassis, is a rack-mounted model for use in control rooms and on central test suites. The Type 714 was produced to Post Office specifications and is now used where a trolley-mounted instrument is required at television repeater stations. Care has been taken in the design of the video amplifiers of the standard picture monitors referred to above, so that distortionless reproduction of the pulse-and-bar signals is assured.

Expensive precision picture monitors (as used in broadcast control rooms) are provided only for control desks and for other special purposes, since the precision of such monitors lies largely in their display geometry, which is of no real interest for the maintenance of television channels.

#### PERFORMANCE TARGETS OF THE POST OFFICE NETWORKS

The performance targets of each of the Post Office television networks are based upon a hypothetical United Kingdom Reference Network made up of four main channels totalling 500 miles, two major local channels and six minor local channels, connected in tandem without overall correction. This reference network is derived from the internationally agreed Hypothetical Reference Circuit<sup>6</sup> considered to have an overall length of approximately 1,600 miles, consisting of three equal-length coaxial cable or radio systems, interconnected at video frequency, without overall correction. The main channels of the United Kingdom Reference Network are of the type used between major cities and employ coaxial cable or radio systems. Local channels are classified as major or minor on the basis of length and complexity, the former being radio systems or multi-repeater cable systems and the latter being mainly short-distance channels employing video transmission over coaxial cables without intermediate repeaters.

Target performance limits have been derived for both the international Hypothetical Reference Circuit and the United Kingdom Reference Network for most of the dominant characteristics of 405-line monochrome television transmission. For some parameters the target performance for the United Kingdom Reference Network has been subdivided to give related performance

#### Target Performances

|   | K-rating‡<br>(per cent) | Non-Linear<br>Distortion<br>(per cent) | Random<br>Noise<br>(db) | Periodic Noise (db) |              | Impulsive<br>Noise<br>(db) | Insertion<br>Gain<br>(db) | Gain Stability (db) |                 |
|---|-------------------------|--|-------------------------|---------------------|--------------|----------------------------|---------------------------|---------------------|-----------------|
|   |                         |  |                         | Hum                 | 1 kc/s-3Mc/s |                            |                           | Short-<br>Term      | Medium-<br>Term |
| International Hypothetical<br>Reference Circuit | 5                       | 20                                     | 50                      | 30                  | 50           | 25                         | 0 ± 1.0                   | ± 0.3               | ± 1.0           |
| U.K. Reference Network                          | 4.5                     | 20                                     | 53                      | *                   | 50           | *                          | *                         | *                   | ± 1.0           |
| Four Main Channels                              | 3.0                     | 15                                     | 55                      | *                   | *            | *                          | *                         | *                   | ± 1.0           |
| One Main Channel                                | 1.5                     | 4                                      | 61                      | 35                  | 55           | *                          | 0 ± 0.25                  | *                   | ± 0.5           |
| One Major Local Channel                         | 1.0                     | 2                                      | 62                      | 35                  | 55           | *                          | 0 ± 0.25                  | *                   | *               |
| One Minor Local Channel                         | 0.5                     | 0.5                                    | 69                      | 35                  | 55           | *                          | 0 ± 0.25                  | *                   | *               |

\* not yet established

‡K-rating denotes the linear waveform-distortion assessment detailed in reference 5. When quoted as above, the term normally refers to the worst individual feature of the distortions caused by a channel, circuit or network.

targets for single channels and for the main section of the reference network, i.e. four main channels connected in tandem.

The table shows the target performance limits so far established for the above reference circuits, networks and channels.

#### SPECIAL TEST FACILITIES

About one half of the Post Office network, i.e. 150 channels, is now composed of channels up to 25 miles in length that transmit the video signal in an unbalanced form over coaxial pairs. These channels are highly stable in performance and require comparatively little routine attention. Remotely-controlled testing facilities have been developed that enable staff at a N.S.C. to connect a testing loop at the distant terminal of a bothway link. Similarly, for channels incoming to the N.S.C. a pulse-and-bar signal may be connected at the distant end by the testing officers at the N.S.C. For other tests, and for routes having outgoing channels only from the N.S.C., visits by a testing officer are necessary at the remote terminals.

The transmission of colour-television signals on temporary closed-circuit television channels and the testing of these channels has been described in a previous article.<sup>7</sup> Such signals have also been transmitted for experimental purposes over certain channels of the permanent network. A modified type of pulse-and-bar generator has been developed for the purpose of testing the gain and phase inequalities between the luminance and chrominance information transmitted over such links. For the subjective assessment of colour transmissions on closed circuits, a transistor-type colour-bar signal generator has been designed using novel techniques which make the production of portable instruments possible for the first time.

Experiments are proceeding with a method of locating gross distortions occurring on television links during the transmission of programs. In this method a test signal, known as a "test line signal," is inserted in lieu of a chosen line in the field blanking period of the composite television signal. Any test signal may be inserted, but current experiments are being conducted using a signal comprising a 20  $\mu$ s white-level bar, a sine-squared pulse of 0.33  $\mu$ s half-amplitude duration and a five-step staircase inserted on line numbers 11 and 213 of the complete frame. Difficulties arise in the extraction of the

signal at the receive end of the channel and in achieving an adequately-bright oscilloscope display of the signal, due to the low duty cycle at which the measuring oscilloscope must operate. A modification of the precision oscilloscope is under consideration in order to give the line-selection facility necessary to display the test line signal.

This review of television testing equipment and methods would be incomplete without mention of the Post Office television outside-broadcast service. Many of the earlier items of portable test equipment were first developed for use with this service and were the forerunners of much of the standard television test equipment now used on the permanent network. In the last few years it has been found possible to standardize most of the test equipment for use as portable and rack-mounted versions required in the N.S.C.s and cable and radio repeater stations, and for television outside-broadcast activities.

#### CONCLUSION

The past achievements in the development of testing equipment and methods for the Post Office 405-line television networks have been described. Development of equipment and facilities for control, monitoring and testing is under continuous review as the networks expand. Extension of the facilities to meet new commitments, such as the testing of 625-line colour-television channels, will be capable of integration with the general pattern evolved for testing the present 405-line monochrome networks.

#### References

- <sup>1</sup>GRANGER, S. H. The New Independent Television Network. *P.O.E.E.J.*, Vol. 52, p. 191, Jan. 1956.
- <sup>2</sup>BLANCHARD, C. H., NEWMAN, W. L., and WILLET, W. M. The Switching of Television Circuits in London. *P.O.E.E.J.*, Vol. 53, p. 102, July 1960.
- <sup>3</sup>LEWIS, N. W. Waveform Responses of Television Links. *Proceedings I.E.E.*, Paper No. 1688R, July 1954 (Vol. 101, Part III, p. 258).
- <sup>4</sup>LEWIS, N. W. Waveform Computations by the Time Series Method. *Proceedings I.E.E.*, Paper No. 1382R, Sept. 1952 (Vol. 99, Part III, p. 294).
- <sup>5</sup>MACDIARMID, I. F. Waveform Distortion in Television Links. *P.O.E.E.J.*, Vol. 52, pp. 108 and 188, July and Oct. 1959.
- <sup>6</sup>C.C.I.T.T. 2nd Plenary Assembly, Dec. 1960, Red Book Volume IV.
- <sup>7</sup>HOLT, J. B. and GARDINER, R. Closed-Circuit Colour Television. *P.O.E.E.J.*, Vol. 53, p. 277, Jan. 1961.

## Book Review

"Plastics Progress 1961." Edited by P. Morgan, Iliffe Books, Ltd. xi + 181 pp. 73 ill. 65s.

This book contains the text of the papers and discussions at the International Plastics Convention, Interplas 1961, in London, and deals exclusively with recent progress in polyolefines, polyvinyls, polystyrenes.

In all the major industrial countries plastics production is now big business and this is reflected in the trend of the papers in this volume where statistics of national or world production and prices are frequently quoted; in fact one might say that the principal themes are thermoplastics, production statistics, and processing.

Another trend which will strike electrical engineers is that the main thermoplastics dealt with, viz., polythene,

polypropylene, polystyrene and p.v.c., are discussed mainly with regard to their non-electrical uses. This, of course, is a reflection of the relatively enormous extent to which the use of plastics in domestic, structural, and packaging, etc., applications has grown.

The more scientific papers on the material side include one on high-pressure and low-pressure polythenes, polypropylenes, and polymers of higher olefines, one on poly styrenes and modified polystyrenes, and one on technical developments in the field of p.v.c.

The four papers on processing thermoplastics deal with single-screw injection moulding, bottle blowing, extrusion practice, and film manufacture.

In conclusion it should be stated that this is a useful reference source on the subjects detailed above rather than a text book.

A.A.N.

# The Testing of Plastics

P. E. TAYLOR, Ph.D., B.Sc., A.R.I.C.†

U.D.C. 620.1 : 678.01

The problems involved in assessing the way in which plastics will stand up to the requirements of Post Office service are discussed. The types of test that are useful in practice are briefly described; the necessity to define the test conditions with great care and to employ refined techniques is emphasized.

## INTRODUCTION

**B**EFORE describing the methods used in the testing of plastics it may be useful to discuss the general principles which underlie the testing of all materials. In the last resort, it is not important what material the manufacturer uses so long as it does its job and will continue to do so for a reasonable period. The question is bound to be asked: What is a reasonable period? There is no hard and fast answer to this question. The designer must balance such considerations as relative costs of alternative materials, ease of manufacture, probable life in service and the degree of reliability needed by the user. To an increasing extent nowadays the possibility must be borne in mind that a piece of apparatus may become obsolete within a relatively short period. It used to be said, not very seriously, that the Post Office required its apparatus to last for 50 years; a reasonable period nowadays would be much less than this.

At an early stage in the design of an item of equipment the designer will require data on the basic physical properties of a material. He will also want to know what methods of fabrication are practicable, whether a material must be moulded, formed from sheet or cast, and so on, and also something of its compatibility with other materials. The answers to these questions indicate whether the material will do the job, and they are largely determined by laboratory examination either of the raw material or of articles manufactured from it. Once a material has been selected it will be necessary to design a specification to control the quality and to ensure that the material chosen has in fact been used.

The second requirement, that a material should continue to do its job for a reasonable period, is one which it is more difficult to test for. It is now generally accepted that the various "accelerated" life tests in common use are an imperfect means of predicting performance and may occasionally be misleading. One of the reasons for this is that the tests are usually designed to study the effect of only one factor which may cause deterioration, while deterioration in actual service will often be caused by the combined effect of several factors. The only completely satisfactory method of evaluation must be the field trial, although in practice it is not as a rule possible to wait for the period of time that would be necessary.

For new materials, and most plastics are comparatively new in this sense, it is necessary to rely on life or performance tests, interpreting the findings in the light of what is known about the chemical structure and composition of the material. In theory it should be possible to predict the physical properties of a plastic merely from a knowledge of its chemical structure. In prac-

tice, although, for example, it is possible to associate ester groupings with high water-absorption, it must be admitted that most of the correlation of physical properties with structure has been on an empirical basis; it can be stated for example, that a material is rubbery and must therefore have cross-linked molecular chains, and so on.

In predicting the life of a material, however, chemical considerations are much more useful. It can be said immediately, that polythene will oxidize in the same manner as any other aliphatic hydrocarbon, that the oxidation will involve chain breakage with reduction in molecular weight, and that the oxidation will be initiated by light, catalysed by one type of compound and inhibited by another. On the other hand, polystyrene, like any other aromatic hydrocarbon, is resistant to oxidation. Rubber has the additive properties of its double bonds and is consequently rapidly attacked by ozone. P.V.C. in ultraviolet light easily splits off hydrochloric acid by a condensation reaction. It cannot be predicted how rapidly these reactions will take place in service and, in any event, the manufacturer will have added inhibitors to prevent or retard them. A knowledge of these reactions is invaluable, however, in predicting the type of failure to which a material is subject and in interpreting the results of life tests.

For routine quality control even the accelerated life tests are often too time-consuming and so are tests required to measure some of the physical properties. For this reason use is made of what may be called identification tests. This approach is widely used in the older technologies where the performance of a material has been established by years of practical experience. To take an example with which everyone is familiar, a lead paint is a suspension of white lead in linseed oil, with minor additions of other substances. A simple analysis will establish that a paint has the correct composition and the life of the paint can then be predicted with some confidence. On the other hand, to confirm that sufficient driers have been added it is easier to determine the drying time than to undertake chemical estimations of cobalt and manganese.

For the identification of plastics the classical techniques of chemical analysis are of limited usefulness. The method used is analogous to finger-printing. In the same way that a finger-print will supply a great deal of information about anyone on the records, a few simple determinations of physical constants which are of little interest in themselves, will enable any common plastic to be identified. The characterization of an unknown plastic on the other hand is a matter of great difficulty and would take a very long time.

Because of the rapid growth of the plastics industry, methods of physical test have been freely borrowed from other technologies and the results obtained by these methods are sometimes of doubtful validity. Common features of all standard methods of test for plastics are the great care that is necessary in defining the conditions and the fine points of technique required in order to get reproducible results. It follows that the results

†Test and Inspection Branch, E.-in-C.'s Office.

obtained are valid only for precise conditions and will not necessarily be obtained in service. At the end of most of the British Standard methods of test for plastics<sup>1</sup> occurs the cautionary phrase: "This figure must not be used for design purposes." Alternatively, this may be expressed by stating that the tests are identification tests and not performance tests.

To illustrate the foregoing with a practical example: if the bursting strength of a steel pipe is known to be 1,000 lb/in<sup>2</sup> it can confidently be expected to withstand 500 lb/in<sup>2</sup> in service for an indefinite period, despite the fact that in the actual proof test the pressure is applied for only a few minutes. If, however, polythene pipe, which is coming into use for water services, is considered, the position is not so clear cut. A pipe which bursts at 2,500 lb/in<sup>2</sup> in 5 minutes will burst at 2,300 lb/in<sup>2</sup> if the pressure is maintained for an hour and at 2,100 lb/in<sup>2</sup> after 100 hours. If the results are plotted on a log/log scale it appears by extrapolation that there is no pressure which the pipe will withstand indefinitely. The problem is not an insoluble one however; many metals show a similar type of fatigue failure. What is done is to calculate the pressure at which the pipe will fail after, say, 50 years, apply a safety factor and take this as a reasonable working pressure for the pipe. It is clear, however, that the ordinary laboratory bursting-pressure test done in a few minutes is not a reliable guide to performance however useful it may be as a quality-control test.

#### TYPES OF TEST

##### Density

The determination of density is widely used in testing plastics. The methods used vary from the obvious one of weighing a rectangular slab of known dimensions to more sophisticated techniques, such as flotation in a column of graded density or weighing first in air and then in water. A recent British Standard<sup>2</sup> specifies that densities should be expressed in grams per millilitre and not in grams per cubic centimetre, as in the past. With regard to the accuracy normally required for testing plastics there is no difference between these two scales.

In moulded or extruded articles, density is a useful control test for the detection of porosity. In a moulded article of fixed dimensions, it is sufficient to weigh the article and it will not be necessary to calculate the density. In plastic foams and sponges a determination first of the apparent density by measuring and weighing a piece and then of the true density, using Archimedes' principle, is a convenient method of determining the percentage of voids.

A less obvious use of density is in the determination of the thickness of sheets of soft plastics as a preliminary to a tensile-strength determination. Any micrometer will give too low a figure owing to the ready compressibility of the material. What is done is to cut out a rectangular piece and weigh it; a separate density determination enables the volume to be calculated. Thence, by measuring the length and breadth, the thickness can be calculated.

Density is an index of composition. It is an aid to identification of plastics although it is greatly affected by the presence of mineral fillers and to a lesser extent by stabilizers, plasticizers and so on. It may also be used to follow changes in state of a plastic. An interest-

ing example is polythene, which has a different density in the amorphous and crystalline states. Provided these figures are known for the variety of polythene under consideration the density enables the percentage of crystallinity, which has a great influence on the behaviour of this material in service, to be calculated.

##### Softening Temperature

Plastics do not as a rule melt sharply at a definite temperature, and the figure obtained in a test for this property is very dependent on the method used. In the current British Standard, "Methods of Test for Plastics,"<sup>3</sup> there are no less than eight different methods given under this heading. Some of the methods measure the temperature at which a defined amount of deformation occurs under carefully defined conditions. Others measure the deformation which occurs at a particular temperature, again under carefully defined conditions. It is usual to select a test which corresponds as closely as possible to the expected conditions of service. Nevertheless the usual caution is added: "This figure must not be used for design purposes."

In general, thermoplastics will flow or deform in service at temperatures well below those found by the above methods of test. An interesting example was found recently of the difficulty of fixing a suitable minimum softening point for a material to be used for a particular application. Complaints were received that the new 700-type telephone<sup>4</sup> would deform in service if placed on a window sill. The trouble was only found with black instruments. After some investigation it was found that the trouble was associated with a particular type of window glass known as Flemish; this has a burning-glass effect at certain critical distances. While the circumstances of the failure were exceptional it was also clear that material with a softening point of 82°C had only a small factor of safety and a grade with a higher softening point has since been specified. Even being wise after the event it is difficult to see how this effect could be predicted from any sort of laboratory examination.

##### Modulus

If a strip of plastic is extended in a conventional breaking-weight machine and stress plotted against strain in the usual manner a straight-line curve is not obtained as with "Newtonian" materials such as steel. The modulus of extensibility is, of course, the slope of this curve, so that although it is quite clear what is meant when the modulus of a steel is referred to, the modulus of a plastic varies with different stresses and requires further definition. It is usual to take the modulus of a rubbery plastic as the stress required to produce unit strain (or 100 per cent extension). The modulus defined in this way is a useful indicator of the stiffness or springiness of a material; the higher the modulus the stiffer the material.

Another peculiarity of the stress/strain curves for some plastics is that they show considerable hysteresis, i.e. the energy used in deforming the sample is not completely recoverable, the lost fraction appearing in the sample as heat. This is of considerable importance in the selection of compounds for car tires. The energy losses vary considerably in different compounds and are great enough to affect the fuel consumption of the vehicle. The heating of the tire is also objectionable, as heat accelerates its aging.

## Cracking

Plastics under continuous stress are liable to crack some time after the application of the stress. The effect appears to be due to the slow propagation of cracks from minute surface flaws.<sup>4</sup> The time taken for the appearance of these cracks can be greatly reduced by the application of certain fluids to the surface. The theoretical basis of this phenomenon is obscure and the choice of fluids empirical, but it does afford a very useful laboratory method of detecting liability to failure in service.

Most moulded or extruded plastic articles contain some locked-in or "frozen" stress. In a thermoplastic this may cause dimensional changes over a period of time and is therefore objectionable. Locked-in stress of this type is detected by a heating test and it is usual to specify a maximum change of dimensions. There is another type of locked-in stress which is a skin effect and which appears in time as surface crazing. This defect can be detected by immersion in a suitable fluid. For example, if it has been incorrectly extruded, p.v.c. shows a dramatic whitening of the surface when immersed in acetone. A recent addition to the list of fluids that are known to produce cracking is zinc chloride for moulded nylon. It was found that moulded-nylon battery boxes rapidly disintegrated in contact with the electrolyte from cells. The boxes were found to have locked-in stresses; annealed boxes were not affected in this way.<sup>5</sup>

The cracking of plastics under externally-applied stresses has been extensively studied in the polythene

Slow cooling from the molten state renders polythene more prone to cracking, for example. The appearance of these cracks can be accelerated by many substances, but Lissapol (a commercial detergent), propanol and silicone oil have been used for test purposes. The Bell Telephone Laboratories have developed a test which is designed to detect variation in the polythene, the other factors, such as the thermal history, being rigidly standardized. It will be noted that this test gives no assurance about the liability to crack of the polythene on the finished cable, which will have had a different thermal history. The importance of the stress-crack resistance of the material on the cable is still open to doubt; it is not known, for example whether, if the Post Office relaxed its requirements, it would be faced with extensive cracking of submarine cables—it would be an expensive experiment. Should it be necessary, however, it would be easy to design a test to measure the stress-crack resistance of the polythene on the finished cable.

## CONCLUSION

The testing of plastics is in a state of rapid development and this is reflected in the large number of different methods of test which are in use or which have been proposed in the technical literature. Those discussed above are representative of the type of approach that has been found to be fruitful. For quality-control purposes the methods available are, in general, adequate though often without a sound theoretical basis. As has been indicated above, the methods of producing data for design purposes are far from adequate, particularly in the direction of predicting life. Work is being done in this field, however, as described, for example, in a recent article in the *Journal of the Plastics Institute*.<sup>6</sup>

When a new plastic is produced it is usually left to the manufacturer to produce data for the designer. In the early stages both the manufacturer of the plastic and the fabricator will necessarily depend on laboratory tests and these, as has been shown, are not always reliable. It should be remembered that manufacturers in general do not see much of the article they manufacture after it leaves the factory. It is only the user who is in a position to assess performance in service. The most any manufacturer can do is to pass on information gathered from other users. The best hope for the future would appear to lie in small-scale field trials of new materials with free interchange of information between various users. This would avoid the position, which has often arisen in the past, of a new and promising material being oversold with consequent disillusionment of the user.

## References

- <sup>1</sup>B.S.2782: 1958. Methods of Testing Plastics (British Standards Institution).
- <sup>2</sup>B.S.3518: 1962. Methods of Fatigue Testing (British Standards Institution).
- <sup>3</sup>SPENCER, H. J. C., and WILSON, F. A. The New 700-Tyne Table Telephone—Telephone No. 706. *P.O.E.E.J.*, Vol. 52, p. 1, Apr. 1959.
- <sup>4</sup>VINCENT, P. I. Testing for Brittle Fracture. *Journal of the Plastics Institute*, Vol. 30, p. 157, June 1962.
- <sup>5</sup>DUNN, P. et al. Failures in Stressed Nylons. *Nature*, Vol. 195, p. 1.093, Sept. 1962.
- <sup>6</sup>GILL, D. A. Long-Term Static Loading on Pipe. *Journal of the Plastics Institute*, Vol. 30, p. 151, June 1962.

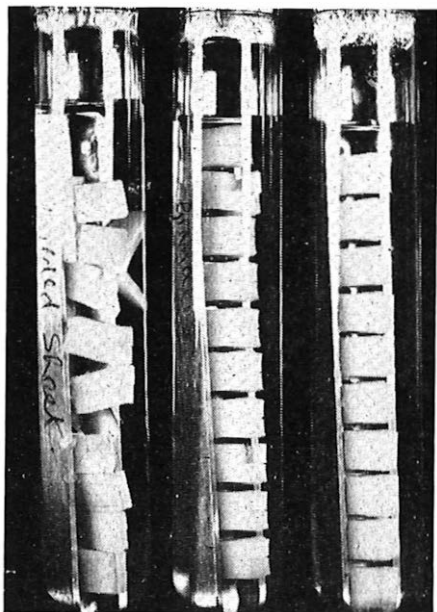

(a) Polythene from Cable Sheath Remoulded and Annealed (All Samples Cracked).  
(b) Polythene as (a) but Test Pieces not Remoulded and Annealed (Two Samples Cracked).  
(c) Another Type of Polythene, Moulded and Annealed (No Samples Cracked).  
STRESS CRACKING OF POLYTHENE

used on submarine cables; examples are shown in the illustration. The liability to cracking has been shown to depend on the type of polythene (its molecular weight and degree of branching) and also on its thermal history.

## Notes and Comments

### **Retirement of Mr. J. J. Edwards, B.Sc.(Eng.), D.I.C., M.I.E.E.**

Mr. J. J. Edwards retired on the 31 October, 1963, after nearly 38 years' service in the Post Office Engineering Department, which he entered in early 1926 through the open competitive examination for Probationary Assistant Engineer (old style).

He obtained his Engineering Degree at the City and Guilds Engineering College, which he attended for three years (1922-5). After spending his training period in the old Metropolitan Power District he was appointed Assistant Engineer (old style) and served four years



as Power Engineer in the Technical Section of the North Eastern District at Leeds.

In 1931 he was transferred to the Construction Section of the Engineer-in-Chief's Office, where he dealt with the design of tools, mechanical aids, etc., and served with the Government Department Committee on the co-ordination of hand tools. In 1935 he was promoted to Executive Engineer (old style) and was responsible for external construction, the introduction of new methods, and special cases involving non-standard construction. He was promoted in 1939 to Assistant Staff Engineer in the Construction Branch and during the war years was responsible for the engineering aspects of war damage and new cable-laying methods for use on aerodromes. In the immediate post-war period he was responsible for the protection of Post Office plant from power-line interference and corrosion, and served on C.C.I.F. commissions.

Early in 1950 he was transferred to the London Telecommunications Region (L.T.R.) as a Regional Engineer, and in 1951 was appointed Deputy Chief Regional Engineer in charge of planning and major works.

In 1954 he was promoted to Staff Engineer, returning to the Engineer-in-Chief's Office to take charge of the Local Lines and Wire Broadcasting Branch. Here one of his major tasks was to streamline the planning pro-

cedures so that service could be provided to outstanding applicants, bearing in mind the extent of capital expenditure possible. Among other things he studied the results of severe storms in North Scotland on depreciation and life of overhead plant, and the effect these conditions had on diversion of this plant underground. Mr. Edwards represented the Post Office on various British Standards Committees, the Users on the Engineering Division Council, and the United Kingdom at international conferences of I.E.C.

In 1958 he was transferred to the Organization and Efficiency Branch of the Engineer-in-Chief's Office. Here he came into close contact with the various Staff Associations and the Post Office Engineering Union. One of the matters settled during his time was the lines of progression and the drafting of the Technician I and Inspector training scheme.

Mr. Edwards also found time to take a keen interest in the sports and social activities in the L.T.R. and the Engineer-in-Chief's Office. This and his very varied experience have made him many friends throughout the Post Office. His sense of humour and his lively personality, together with his active interest in his work and his colleagues, will be missed by all who knew him. Recently his health has not been good and but for this he would probably not have retired so soon after his 60th birthday. He leaves with the best wishes of all for a speedy return to good health so that he can enjoy to the full many years of happy and well-deserved retirement.

J.S.

### **F. W. J. Webber, B.Sc.(Eng.), A.M.I.E.E.**

The appointment of Mr. F. W. J. Webber to succeed Mr. J. J. Edwards as Staff Engineer in charge of the Organization (Efficiency) Branch means the well-deserved promotion of the most experienced member of that Branch.

Bill Webber is rightly proud of the fact that he has risen from the ranks, having joined the Radio Branch of



the Engineering Department in 1928 as a Youth-in-Training. He had already shown that he had the adventurous spirit and enquiring mind so much needed in engineering by going to sea as a radio operator at the age of 15. His academic ability later gained for him the distinction of an Honours B.Sc. Engineering degree in Electrical Engineering following a five-year part-time evening course at the University of London. After promotion to Inspector in 1933 he spent three years in the Equipment Branch on the design of telephone-exchange power plant. He was then successful in the 1936 Limited Competition for Probationary Assistant Engineers (old style) and remained in the Equipment Branch for another three years. During this period he made a valuable contribution to telephone-exchange equipment design and contract work.

At the outbreak of the Second World War he was transferred to the South Western Region Engineering Branch where, until 1946, he was able to put his expert knowledge to good effect in the planning and provisioning of the many types of automatic-exchange and other equipment required for civil and defence purposes. In June, 1946, he was seconded to the Control Commission for Germany as Deputy Controller, and for just over two years helped in the restoration of the telecommunication services. On his return to the Post Office in 1948 he was promoted to Senior Executive Engineer and carried out his first spell of duty in the Organization Branch as it then was. His varied experience must have served him in good stead in dealing with the many problems of the Telephone Areas, but these seem also to have inspired him to seek more first-hand knowledge. In 1951, at his own request, he was transferred to the London Telecommunications Region (L.T.R.) East Area where he served over five years on a number of duties including planning, external construction and installation work, and a spell as the L.T.R. Efficiency Engineer. His all-round ability was recognized when in 1956 he was promoted Assistant Staff Engineer and found himself back in the Organization and Efficiency Branch of the Engineering Department. Since then he

has been responsible for many important negotiations with Staff Associations, and the Post Office Engineering Union in particular, on grading and associated problems. On this work, his high integrity and meticulous care, coupled with sound judgment of men and affairs, have proved invaluable.

There can be few engineers as well qualified as Bill Webber to take over the leading role in his own Branch, and his colleagues and many friends will be wishing him every success in it.  
N.C.C. de J.

#### Journal Price Increase

The last price increase of the Journal was from 2s. to 2s. 6d. per copy and commenced with the April 1960 issue. Since that issue the cost of producing the Journal has increased to the point where, to maintain the standard of the Journal, another increase in price is now necessary.

With the agreement of the Council of the Institution, the Board of Editors has recommended an increase in the price of the Journal from 2s. 6d. to 3s. per copy commencing with the April 1964 issue. Also, due to the increase in the cost of postage and packing, it will be necessary to increase the post-paid price from 3s. 6d. to 4s. per copy (16s. per year, post paid) via inland mail, and from 3s. 6d. to 4s. 3d. per copy (17 shillings or 2 dollars 75 cents, Canada and U.S.A., per year post paid) via overseas mail, commencing with the April 1964 issue.

Journals ordered by a subscription submitted before the end of 1963 will continue to be supplied at the old price until the subscription expires.

Post Office staff paying for the Journal by deductions from pay will have their deductions automatically adjusted unless they notify their pay-points that they are withdrawing their subscription to the Journal.

#### Journal Binding

This issue completes Vol. 56 and readers wishing to have this volume bound should refer to page 297 for details.

---

## Institution of Post Office Electrical Engineers

#### Annual Awards for Associate Section Papers—Session 1962-63

The Judging Committee having adjudicated on the papers submitted by the Local Centre Committees, prizes and Institution Certificates have been awarded to the following in respect of the papers named:

*First Prize of £7 7s.*

G. D. Adam, Technical Officer, Aberdeen Centre—"An Introduction to Computers and Programing."

*Prizes of £4 4s. each*

C. E. Cox, Technical Officer, Middlesbrough Centre—"The Earth's Natural Satellite."

A. M. Duff, Technical Officer, Aberdeen Centre—"Program Circuits."

In addition, the following paper, which was considered worthy of submission to the Judging Committee, has been awarded a prize of one guinea:

T. J. Wells, Technician IIA, Tunbridge Wells Centre—"British Railways Signalling and Telecommunications."

The Council of the Institution is indebted to Messrs. J. Baines, F. Haliburton and A. W. Hunt for kindly under-

taking the adjudication of the papers, and to Mr. J. Baines, Chairman of the Judging Committee, for the following report:

The Judging Committee were impressed by the high standard of the papers submitted. The winning paper submitted by Mr. Adam was exceptionally well planned and presented. He tackled a difficult subject, and one on which he had little or no official sources of information, in best lecture and text-book style.

The papers submitted by Messrs. Cox and Duff were of equal merit in their different ways. That by Mr. Cox, "The Earth's Natural Satellite," broke fresh ground, dealing as it did with a subject not normally associated with telecommunications but which is growing in importance. It was obvious that the knowledge and enthusiasm of the author was such as to have ensured a highly successful meeting.

Mr. Duff's paper, "Program Circuits," was within the more normal experience of a Post Office audience, and would have been most interesting and instructive not only



to those immediately concerned with the provision and maintenance of circuits but to all who are interested in the special services provided by the Post Office.

Mr. Wells' paper, "British Railways Signalling and Telecommunications," was more limited in scope than the other papers but was interesting and informative.

S. WELCH,  
General Secretary.

#### Additions to the Library

Library requisition forms are available from Honorary Local Secretaries, from Associate Section Centre Secretaries and representatives, and from the Librarian, I.P.●.E.E., G.P.●., 2 12 Gresham Street, London, E.C.2.

2726 *The Exploration of Outer Space*. B. Lovell (Brit. 1962).

Deals with the techniques of investigation, the solar system, the structure, origin and evolution of the universe, and with the ethical and scientific dangers of space exploration.

2727 *Servicing Transistor Radios and Printed Circuits*. L. Lane (Brit. 1962).

Aims at giving a working knowledge of the theory of transistors as well as the practical applications and techniques.

2728 *Electrical Engineering for O.N.C. Vol. 4—D.C. Machines*. G. N. Patchett (Brit. 1962).

The fourth of five volumes covering the Ordinary National Certificate syllabus in Electrical Engineering. Deals with the principles of d.c. machines, armature windings, armature reaction, commutation, no-load and load characteristics of both motors and generators, losses and efficiency, starters and starting.

2729 *Radio and Television Servicing (1962/3 sets)*. J. P. Hawker (Brit. 1962).

Gives the servicing and setting up details of 1962 63 radios and televisions.

2730 *Electrical Engineering for O.N.C. Vol. 5: Basic Electronics*. G. N. Patchett (Brit. 1963).

Deals with metal and semiconductor rectifiers, the diode rectifier, rectifier circuits and the triode and transistor both as regards characteristics and their use as an amplifier.

2731 *Electrical Engineering for O.N.C. Vol. 3: A.C. Theory*. G. N. Patchett (Brit. 1963).

Deals mainly with a.c. and the flow of these currents in circuits of various kinds. Power in a.c. circuits and balanced three-phase circuits are covered. There is a chapter on the transformer.

2732 *Equations and Graphs*. K. Austwick (Brit. 1963).

Sets out in detail the techniques of equation solving and graph drawing and equation rearrangement and is not primarily concerned with the sources from which the equations and graphs arise or in their applications.

2733 *Mathematics for the General Course in Engineering. Vol. 1*. J. Moore (Brit. 1963).

This covers the syllabus in mathematics for the G.I. Year of the new General Course in Engineering.

2734 *More About Loudspeakers*. G. A. Briggs (Brit. 1963). Up-to-date information on design and performance in non-technical terms.

2735 *Fundamentals of Electrical Measurements*. C. T. Baldwin (Brit. 1961).

A concise introduction to the theory and practice of electrical measurement.

2736 *Silent Spring*. R. Carson (Brit. 1962).

The author shows how the balance of nature must not be disturbed in a way that will ultimately do more harm than good; how the lethal chemicals are self-defeating by virtue of resistant strains being bred.

2737 *One, Two, Three . . . Infinity*. G. Gamow (Brit. 1962).

An attempt to collect the most interesting facts and theories of modern science in such a way as to give a general picture of the universe in its microscopic and macroscopic manifestations.

W. D. FLORENCE,  
Librarian.

## Book Review

"Fundamentals of Semiconductor and Tube Electronics." Professor H. A. Romanowitz. John Wiley & Sons, Ltd, xii + 620 pp. 453 ill. 62s.

The book covers an extremely wide variety of topics in electronics—perhaps too wide a variety. Chapter 1 is a very useful introduction to basic circuit theory; it is followed by a chapter describing measuring instruments. Chapter 3 deals with elementary semiconductor physics and contains some misleading and inaccurate ideas. Thus in Fig. 3-2 a conduction band is shown as a physical region surrounding a single germanium atom, whereas it is in fact a range of energy levels and can only exist in an assembly of many atoms, such as the crystal lattice of a semiconductor. Section 3-6 implies that p-n junctions are always made by "growing"; diffusion, very widely in use at present, is not mentioned. The first sentence in section 3-12 is highly misleading. The concept of tunnelling presented in section 3-20 is wrong; electrons do not need to acquire a high energy in order to tunnel through a thin barrier. The term "doping compounds" applied to the intermetallic compounds is unhelpful, and on p. 103 the concept of Fermi level is introduced without definition, though it is explained later in the book. Chapter 4 deals with semiconductor diodes and includes the statement that avalanche operation is not harmful; some workers would

disagree with this. The next three chapters are well presented and deal with thermionic emission, thermionic valves, and with rectifiers and power supplies. Chapter 8 contains a useful introduction to transistors, but equations 8-5 and 8-6 are only approximations, an important fact in high-frequency work.

The next two chapters deal with the use of thermionic tubes and transistors as amplifiers. While the material on thermionic tubes is good, the sections on transistor amplifiers ignore the important topic of d.c. stabilization. Thus Fig. 8-11 and 8-12 show impractical methods of d.c. biasing, and the most commonly used stabilizing circuit is omitted. Chapters 11 and 12 deal with power amplifiers and special amplifying circuits, and include a class B amplifier, shown in Fig. 12-14, which would in practice produce considerable crossover distortion. Fig. 12-22 shows another quite impractical circuit.

The book concludes with chapters dealing with feedback amplifiers, oscillators, switching circuits, gas-filled tubes, rectifiers and invertors, and photo-electric devices. A final chapter contains a collection of electronic circuits for typical applications.

While the book contains much useful information, the sections dealing with semiconductors cannot be recommended.

H.G.B.

# Regional Notes

## North Western Region

### THRUST-BORING ON THE M6 MOTORWAY

In connexion with the linking-up of the new Birmingham-Preston motorway (M6) with the existing Preston by-pass, it was required to continue the new emergency telephone system, which consists of emergency call points at one-mile intervals at each side of the road, throughout the length of the by-pass. These points are served by a cable which runs along one side of the road and is connected to the opposite call point by a cable crossing the motorway. No provision for this service was made when the by-pass was constructed in 1958, and eight crossings were required to connect up the system. Excavating across the carriageways was unacceptable, so it was decided to make the crossings by thrust-boring.

The width of the motorway from verge to verge is 100 ft, so it was decided to make the bores under each of the carriageways in two separate thrusts from the 34 ft-wide centre reservation. To avoid damage to the drainage system, the borings had to be at a depth of 4 ft 6 in. The excavations for the boring machine were made 6 ft from the carriageways, and were connected by a trench across the centre reservation.

The purpose of the trench was as follows:

(a) To allow for small deviations in the alignment of the two ducts so that they could be continuously connected by means of their screwed collars.

(b) To avoid damage to the main drains lying in the centre reservation.

(c) To reduce the amount of thrust-boring required.

The thrust-borer used was a petrol-engine-driven hydraulic type giving a pressure of up to  $1\frac{1}{2}$  tons/in<sup>2</sup>.

The first bore under the north-bound lane, using a 4 in. steel pipe, was completed in two hours. Unfortunately, due to the boulder fill used in the road construction, the other half of the bore under the south-bound lane had to be abandoned after three days of boring. In order to carry out a successful crossing, the location had to be moved to a point 30 yd away, and then it was only achieved by using a 2 in. pipe.

As accurate lining-up of the two crossings was essential, it was necessary to rebore the north-bound road and draw in a 2 in. pipe. It was then decided that, because of the type of road construction, a 2 in. pipe would be used at all crossings to reduce the loading on the thrust-borer.

Of the eight crossings, five were completed with screwed joints throughout, and two were out of alignment and had to be coupled by means of asbestos-cement pipe with rubber collars. The last crossing was at a slip road where there was a narrow centre reservation containing no drains; this was completed in one continuous thrust via a pilot hole in the centre reservation.

The successful completion of the work was due in no small measure to the assistance and close co-operation received from the Lancashire County Surveyor's Department.

W.G.

### SUBMARINE CABLE ACROSS MORECAMBE BAY

The existing main cable route from Lancaster to Barrow-in-Furness follows the A6 trunk road as far as Levens Bridge, and then branches westward via Ulverston, a distance of approximately  $45\frac{1}{2}$  statute miles. Three cables already follow this route, and there have been continuous maintenance difficulties caused by excessive cable creepage, particularly where the route crosses the marshy ground between Levens Bridge and Lindale. The need to provide a fourth cable prompted the decision to lay a single-tube 0.935 in. coaxial cable of subaqueous type across

Morecambe Bay between Rampside, Barrow, and Half Moon Bay, Heysham, a distance of 9.8 nautical miles.

Morecambe Bay is geographically the tidal portion of three fast-flowing river estuaries, and at high tide does not give a sufficient depth of water over the sandbanks to allow the use of a conventional deep-sea cable ship. As the laying operation could not be completed during one tide, it was necessary to be able to beach the cable ship. The only cable ship with a flat bottom and drawing only 7 ft of water, is Rijkskabelschip *Poolster* owned by the Dutch P.T.T., and this was chartered for the lay. *Poolster*, shown in the photograph, is a motor vessel of 458 tons displacement, 145 ft long with a beam of 22 ft, draught of



CABLE BEING HAULED ASHORE FROM *POOLSTER*

7 ft and a speed of 8 knots. The coiling capacity of the cable tanks is 4,310 ft<sup>3</sup>, and it has a maximum laying depth of 34 fathoms. The crew consists of 15 men including officers.

On the 22 and 23 July 1963, *Poolster*, in a combined operation with Lancaster Area staff, laid a continuous length of single-tube 0.935 in. coaxial cable of 9.8 nautical miles, including two long beach crossings of 900 yd and 600 yd, at Rampside and Half Moon Bay, respectively. The method of crossing the beaches at each landing point consisted, basically, of hauling the cable on ball-bearing cable rollers, spaced 5 yd apart, using a Caterpillar or Fordson Major tractor, and then finally burying the cable in a trench dug by a sub-soiler.

The staff required was assessed to be 42 men, and they were fully briefed in all aspects of the operations. Operations on the beach were directed by an Assistant Engineer assisted by two Inspectors—one responsible for the control of personnel, and the other for the co-ordination of the

traction unit. To speed the passage of orders between the cable ship, the shore control and the two Inspectors, walkie-talkie radio was used. Transistor-type loud-hailers overcame the difficulties of giving direct orders. When the tide had receded about 50 yd, the first working party commenced excavations on the beach to locate the steel pipes which had been laid previously and were required to carry the cable to the jointing point with the land cable. The water level in the trench was controlled by a portable pump. After the tide had receded to 100 yd, a survey party, using standard survey rods, began to plot a route in a straight line between the beached cable ship and the shore beacons.

A Landrover loaded with cable rollers was driven slowly along the marked route, and rollers were handed to a man walking at the rear who placed a roller on the shore at intervals of 5 yd. A second man accurately positioned the rollers. Two Landrovers were used and as each emptied it returned to land for re-loading. The laying of rollers continued to within 20 yd of the ship. The objective of having a straight line of rollers was readily attained by this method.

With water still about 4 ft 6 in. deep, the cable was passed from the cable ship over the bow sheaves to the shore party, and connexion was made with a hawser to a Fordson tractor, which was then driven slowly towards the line of cable rollers. To support the cable over this distance, rubber-tyred pole carts were placed under the cable at 3 yd intervals, but not fastened to it. When a pole cart reached the first cable roller it was returned to the nearest point to the ship. The Fordson Major tractor, carrying an Inspector with a walkie-talkie radio, was then driven, astride the cable rollers, slowly towards the shore. To obviate language difficulties, and to co-ordinate orders, the First Officer of the cable ship, also equipped with personal radio, walked alongside the tractor.

Men were posted at intervals of 25-35 yd to replace the cable when it came off the rollers, and to do this each man was equipped with a wooden pick handle as the handling of the cable while in motion had been strictly prohibited.

The length of cable to be drawn through the steel pipes was obtained by driving the tractor 50 yd beyond the shore-end of the pipe, at which point the cable was uncoupled. The tractor then returned 50 yd along the cable to where a cable anchor had been attached, and the hauling process was repeated while about 20 men manoeuvred the cable into a large loop ready for drawing into the steel pipe. Rodding and roping of the steel pipes had previously been undertaken and a winch set up at the jointing chamber on land. A standard cable grip was attached to the cable, and the cable, complete with armouring, was drawn through the steel pipes without difficulty.

The complete operation, from taking the cable from the ship to handling over to the jointers on land, took 1 h 50 min at Rampside, but was delayed at Heysham while 600 yd of surplus cable was taken off and then returned to the cable ship's tanks. At Heysham, the beach crossing to the end of the steel pipes took 30 min, and the whole operation was completed in 5 hours.

The laying of the cable across the bay was undertaken at night, and was assisted by lighted beacons located on the land at Rampside using electric floodlights powered by standard 24-volt generators. A motor launch equipped with radio preceded the cable ship to guide it to marker buoys previously located on the proposed route. A volunteer gang of five Area staff were taken aboard *Poolster*, while at sea, to assist the Dutch crew to free the end of the cable coil for landing at Heysham.

The success of the operation was due to the close liaison between the Dutch Submarine Cable Superintendent, Engineering Department staff and Lancaster Area staff throughout the planning and execution of the landings. It was also due to the briefing which every man of the shore

party received, giving him background information as well as the detailed operations that were required.

S.J.R.

#### North Eastern Region RENEWAL OF UNDERGROUND PLANT DAMAGED BY GAS EXPLOSION

A gas explosion in January 1963 resulted in severe structural damage to six manholes and some 1,200 yd of 9-way multiple duct located in the footway of the main Leeds-Bradford road. The explosion occurred at about 7.50 a.m., and in spite of its obvious force there were no reports of damage to persons, private property or other services. This was surprising because heavy traffic was passing at that time and manhole covers damaged by the explosion were scattered over a wide area. The full extent of the damage was not immediately apparent due to the presence of gas and water in the track, and a 4 in. covering of frozen snow prevented a close visual inspection of the surface.

When the plant had been cleared of gas, a more detailed survey revealed that some manholes were unsafe and required shoring. That there was a complete collapse of the duct over a large part of the route was proved by test-rodming and excavation of pilot holes. As a number of attempts to rod spare bores had proved to be abortive, and since no replacement of faulty cable lengths would have been possible, pressurization of the whole affected section was immediately put in hand. This was thought to be desirable in view of the importance of the cables involved, which included trunk carrier cables between Edinburgh and Leeds, and junction carrier cables between Bradford and Leeds.

Other points of interest included the following:

- (a) Structural damage to manholes was most severe where covers were frozen into the frames.
- (b) Radial cracks appeared in the paved surfaces adjacent to damaged manholes.
- (c) Explosions appear to have occurred in pockets, due to the contours of the land, and in different bores of the track. At no point were all nine bores completely shattered.
- (d) Cable damage was restricted to a slight flattening of the joints in damaged manholes.

Various methods of making permanent repairs were considered and discussed with Regional Headquarters and the Engineering Department. The most attractive scheme appeared to be excavation and visual examination of the damaged track and its replacement with split duct where necessary, and the demolition and rebuilding of damaged manholes. The cables would be slung clear while broken

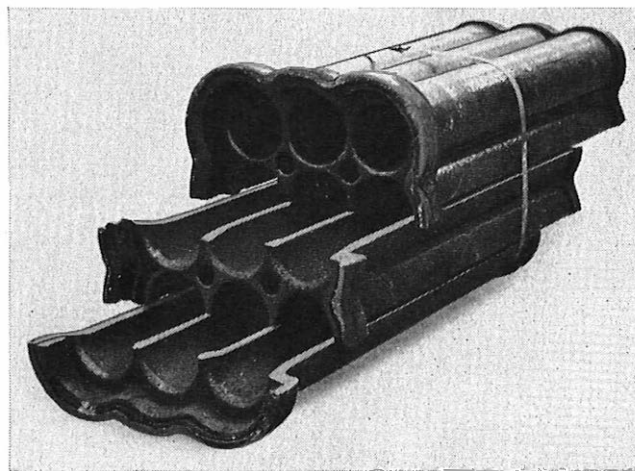

SPECIALLY-GROOVED 9-WAY MULTIPLE DUCT

duct was removed, and the cables carefully examined to check they were undamaged before being replaced.

Special 9-way multiple duct was obtained, the top three bores having no groove for splitting. A sample of the duct is shown in the photograph. These were banded with steel tapes and consolidated with lean-mix concrete on both sides up to the indent between top and centre bores. Although a wide trench was desirable for inspection and replacement, space was, in fact, limited because of the presence of other services. In order to obtain sufficient slack to sling the cable clear of the broken duct, it was necessary to maintain a long open excavation and this resulted in extensive timbering and supporting of other services. Lengths of split p.v.c. fall-pipe were used to prevent cable-sheath damage from rope ties. All broken duct was removed from the trench prior to re-laying. This proved to be difficult due to sharp splinters of broken duct adhering to the protective grease on the cable, so white spirit was used to wash the cables and facilitate inspection. Normal leak detection was carried out immediately prior to replacement of cables in the new duct.

The whole of the work was carried out by contract under P.O. supervision.

E.L. and R.W.B.

#### Northern Ireland

#### BELFAST NEW CIVIL AIRPORT

At midnight on 25 September the transfer was completed of the final stage of the telecommunication installation at the new airport at Aldergrove, Belfast.

The first stage of the transfer was effected on 27 August when a new air-traffic-control tower was brought into service for the joint use of the Air Ministry and the Ministry of Civil Aviation.

The equipment installed for the civil air terminal includes a 400-line manual exchange (P.M.B.X. No. 1A) with out-of-area exchange lines to Belfast Central exchange, v.f. telegraph equipment, teleprinters, house exchange systems, call-office circuits and radio-terminal equipment. Eventually

a 500-line automatic exchange (P.A.B.X.) will be installed. The major items of equipment are concentrated in three adjacent rooms, divided by aluminium partitions which necessitated the over-ceiling method of cabling to the switchboard. Floor ducts were provided for carrying the cables from the main distribution frame (M.D.F.) to apparatus racks and the teleprinter room, and to connect with the main fibre-glass duct distribution network within the building.

In the teleprinter room, consoles specially designed for the Ministry of Civil Aviation were used. These were designed so that the equipment was accessible for maintenance purposes both from the front and from the rear.

A late request to provide two 405-line vision circuits from the air-traffic-control tower to the briefing room in the air terminal required the installation of two racks of video equipment, the laying of 1.25 miles of gas-pressurized coaxial cable consisting of two 0.375 in. tubes and 16 interstice pairs. The installation was provided to brief civilian air crews at the air-terminal building, from the meteorological office in the tower, which is on the opposite side of the main runway.

The work also included the augmentation of the local-line plant on the existing part of the airport, and laying new plant to the new buildings. The public automatic telephone exchange serving the airport was extended to cater for an anticipated increase in traffic from the airport, and transmission equipment was installed at the nearest repeater station to cater for the additional private wires.

Each phase of the work was closely co-ordinated, and frequent on-site meetings were held to overcome the many problems involved in such a complex program.

In the final event, the transfer arrangements were tested sooner than was anticipated: on the very day of transfer adverse weather conditions at the old airport prevented the last scheduled flight from landing. It was therefore diverted to the new airport 90 minutes ahead of scheduled transfer time.

T.P.McM.

## Associate Section Notes

#### Bradford Centre

The following officers have been elected for the 1963-64 session: *Chairman*: Mr. E. Dennison; *Secretary*: Mr. R. C. Siddle; *Treasurer*: Mr. D. P. Killen; *Librarian*: Mr. D. Relton; *Committee*: Messrs. J. Pickles, M. Firth, K. Grunwell, R. Winterburn, G. Bown and M. Galloway.

A varied program has been arranged and will include visits to Mullard's valve factory, Blackburn, Baird Television, Ltd., Bradford, a visit to a bakery, and a visit to a British Railways vessel at Heysham. Talks will include "Colour Photography" by Mr. R. A. Burns, "Telex Auto" by Messrs. K. H. Grunwell and G. Harrison, and "My Year in Norway" by Mr. J. Archbold. R.C.S.

#### Middlesbrough Centre

At the annual general meeting held in April, the following officers were appointed: *Chairman*: Mr. N. Williams; *Secretary*: Mr. D. Campbell; *Treasurer*: Mr. K. Ashworth; *Librarian*: Mr. M. A. Launders; *Committee*: Messrs. H. Daggett, D. A. Pratt, E. E. Sparks and J. O'Connor.

The following program was arranged for the coming year and is well underway:

29 October: "The Development of the Motor Car," by Mr. R. D. Purvis.

26 November: "Photography," by Mr. E. A. Clarke.

17 December: Visit to A.E.I., Ltd., Hartlepool.

14 January: Visit to a Police Station.

27 January: "Amateur Brewing and Wine Making," by Mr. M. Lilley.

25 February: "Story of a Hive," by Mr. W. Outhwaite.

30 March: "Exchange Visit to Sweden," by Mr. N. Williams.

April: Annual general meeting.

The membership of the Branch continues to grow, and it is hoped that the facilities offered by our local library can be improved to meet the growing demand. D.C.

#### Darlington Centre

The Darlington Centre was re-formed with a membership of 40, following a meeting held at Durham on 24 May.

The Centre received an invitation from the Atomic Energy Authority to a tour of Windscale on Saturday, 19 October, and, thanks to the co-operation of the Middlesbrough Centre, a full bus was assured.

The Centre would like to acknowledge invitations from Paton and Baldwins, Ltd., wool manufacturers, and the Central Electricity Generating Board to tour their works and installations. Also, to Major W. F. M. Hawkins, Secretary of the Catterick Branch of the Royal Signals Institution for the establishment of close relations with the Institution, the immediate result of which is an invitation to attend a lecture, sponsored by the Institution of Electrical Engineers entitled "Pulse Techniques in Line Communications," by Mr. R. O. Carter, Research Branch, Engineering Department. The Centre is grateful to Sir Albert Mumford, K.B.E., Engineer-in-Chief, for his consent to visit H.M.T.S. *Ariel*, whilst she was in dry dock at Hebburn-on-Tyne.

Officials of the Centre are: *Chairman*: Mr. C. F. Bellwood; *Secretary*: Mr. E. W. Scott; *Treasurer*: Mr. J. D. Cox.

A cordial invitation to attend our lectures is extended to other Centres and to Senior Section members. The following lectures, commencing at 7.30 p.m., and given at the Mechanics Institute, Skinnergate, Darlington, were held from October to December, and will continue during February and March:

29 October: "Work Study," by Major R. Hirst.

26 November: "Valves and Transistors," by Messrs P. Barton and E. O. M. Grimshaw.

17 December: "History and Husbandry," by Mr. C. W. Percy, Principal of the Durham School of Agriculture.

25 February: "The Earth's Natural Satellite," by Mr. C. E. Cox.

31 March: "The Garden," by Mr. S. J. Cox, Head of Horticulture, Durham School of Agriculture. E.W.S.

#### Aberdeen Centre

The annual general meeting was held on 1 August when the following officials were elected: *President*: Mr. J. B. Duff; *Vice-Presidents*: Messrs. J. J. Loughlin and J. McLeod; *Chairman*: Mr. R. T. Ross; *Vice-Chairman*: Mr. J. H. Lawrence; *Secretary and Treasurer*: Mr. D. White; *Assistant Secretary*: Mr. G. D. Adam; *Librarian*: Mr. P. McAnulty; *Auditors*: Messrs. E. D. Petrie and G. Milne; *Committee*: *Aberdeen*: Messrs. A. Forster, G. Fox, J. Pike, J. H. Robertson, R. Sandison, J. H. Simpson, A. Webster, W. Williamson and R. Yule; *Inverness*: Messrs. A. Grant and J. C. Hines; *Peterhead*: Mr. J. D. Elder; *Wick*: Mr. R. T. Black; *Lerwick*: Mr. R. Mathewson; *Elgin*: Mr. C. McKee; *Kirkwall*: Mr. J. D. Nutson; *Huntly*: Mr. F. Marshall.

Tribute was paid to our Chairman who has been in office for ten years.

During the remainder of this session it is hoped to include visits to a distillery, a Royal Naval air-base flying-control tower and to International Computers and Tabulators, Ltd.

The first meeting, in September, was a film show which included the film made of our visit to the Forth road and railway bridges earlier this year. Our cameraman, Mr. J. Jule, obtained some very impressive shots of passing trains from the overhead supports of the railway bridge, and then "shot" his headgear as it plunged into the river! D.W.

#### Bedford Centre

The inaugural meeting of the Bedford Centre was held at 7.15 p.m., on Monday, 30 September, and for those who had a hand in its formation it was very gratifying to start with a membership of 80. Mr. R. V. Sanders, the Home Counties Regional Liaison Officer, was in the chair and we were pleased to welcome amongst us the Telephone Manager of Bedford Area, Mr. H. Jeffs, and the two Area Engineers, Mr. J. H. Facer, President, and Mr. F. T. Weston, Vice-President. The place of honour was given to the Associate Section National President, Mr. A. J. Leckenby, M.B.E., Deputy Chief Regional Engineer, Home Counties Region. He spoke about the Institution in general terms for a few minutes, laying stress on the desirability for members to submit papers and to enter the essay competition, after which he welcomed the Bedford Centre into the Associate Section.

The Officers and Committee were then elected as follows: *Chairman*: Mr. D. J. Coleman; *Secretary*: Mr. E. W. H. Philcox; *Assistant Secretary*: Mr. I. Harris; *Treasurer*: Mr. D. C. Frossell; *Committee*: Messrs. L. M. Westall, G. A. Coles, H. A. Fletcher and D. A. Crampton, Additional members of the committee may be co-opted as required.

At 8.0 p.m., Mr. A. H. C. Knox, Chief Regional Engineer, Home Counties Region, gave a talk to a combined audience of Bedford Associate Section and Senior Section members. He made his subject, the very controversial one of "Appraisal and Promotion of Engineering Staff," very interesting, handling it with skill and dexterity. After about half an hour of questions, the meeting closed at 9.45 p.m.

The following two lectures have been held this session so far:

Thursday, 31 October: "Rocket Propulsion," by Mr. D. Carton, College of Aeronautics, Cranfield.

Monday, 9 December: "Gas Pressurization of Cables," by Messrs. R. A. M. Light and H. P. Brooks, Main Line Development and Maintenance Branch, Engineering Department.

Further lectures arranged for the 1963-64 winter session are as follows:

Tuesday, 21 January: "The Work of the B.B.C. Sound Effects Department," by Mr. H. B. Hadden.

Wednesday, 4 March: "Developments in Post Office Research," by Mr. J. Piggott, Research Branch, Engineering Department.

April (date to be fixed): "The Laying of Submarine Cables," by Mr. H. E. Robinson, External Plant and Protection Branch, Engineering Department.

It is our hope that before very long our membership will exceed 100 members, and that the initial enthusiasm will continue and grow. E.W.H.P.

#### Bletchley Centre

The winter session commenced with a technical film show, at which the following films were shown: "Job 99-Pluto," the story of a war-time project for the invasion of Europe in the 1939-45 war; "The Captive River," an interesting and amusing story of the Kariba Dam construction and the rescue of wild animals from the flooding valley; and "Super Grid Construction," a film which highlighted the problems and dangers of constructing an overhead high-voltage system.

Members of the Centre were also invited to one of the meetings at Bedford organized by Mullard, Ltd., where they were introduced to the field of ultrasonics, a subject which may be new to the Post Officer engineer.

Shortly after this visit a new Centre was formed at Bedford, which has caused a loss of 16 members from the Bletchley Centre reducing our membership to 100. The officers and committee would like to wish every success to the new Centre.

It is hoped that by the time this report has been printed we shall have visited the new telephone exchange building at Luton, and also a factory manufacturing telephone equipment and exchanges. A.J.H.

#### Bournemouth Centre

Our membership has again increased this quarter and is now 92 members.

On 24 August, a party of 20 attended a demonstration of advanced driving at a police driving school. This started with 20 hair-raising (but highly informative) minutes on the skid-pan, followed by a 25-mile drive in a police car, showing clearly the many ways in which driving can be made safer.

On 5 September, 38 members and guests visited the Ford motor works at Dagenham and spent a most interesting and enlightening afternoon.

A further small party of our members were conducted round the B.B.C. television centre on 8 September.

A.E.A.B.

#### Exeter Centre

On behalf of the committee and members of the Exeter Associate Section, we would thank the staff of the

experimental satellite ground station at Goonhilly Downs for the excellent manner in which they conducted our party over the station.

We are looking forward to a continuation of the varied set of lectures during the winter session, with the main theme being "Submarine Cabling" and the associated subjects of "Repeaters" and "Dialling." F.R.S.

#### Gloucester Centre

The activities of the 1962-63 session started in June 1962 with a combined visit to the B.B.C. television centre and to the Circuit Laboratory, Engineering Department, Armour House, London. Visits were also made to the police driving school, Devizes, in August, and to W. D. & H. O. Wills, Ltd., Bristol, in September. These visits were much enjoyed by the many members taking part, who extend their grateful thanks to the various organizations that made them possible.

The following meetings were held during the 1962-63 winter session:

2 October: Messrs. Wilson and Leckenby gave their talk "Telecommunications in the Netherlands." It was regrettable that only a few members took the opportunity of enjoying this first-class talk.

22 November: With the aid of slides and a film, Captain F. P. T. Betson, Submarine Branch, Engineering Department, explained the "Work of the P.O. Cable Ships." It was gratifying to see a large audience at this entertaining talk.

16 January: Sergeant Mock, a member of the local police, gave us an insight into the "Work of the Police Service." The talk was followed by a barrage of questions, all of which were most ably answered.

21 February: The annual general meeting was followed by a viewing of 8 mm films shown by Mr. G. H. Adams, one of our members. The few members present congratulated Mr. Adams on the professional quality of the films.

5 March: Mr. J. Fielding explained "Cable Pressurization" with the aid of slides and several demonstrations. Coinciding with the introduction of cable pressurization at Gloucester telephone exchange, this proved a topical and instructive talk.

4 April: Mr. D. R. Barber of the Central Electricity Generating Board gave a talk on "The Grid System" that was much appreciated.

The following officers and committee were elected: *President*: Mr. T. H. McDonald; *Vice-President*: Mr. R. T. Hoare; *Chairman*: Mr. A. H. Franklin; *Vice-Chairman* and *Librarian*: Mr. N. Mountjoy; *Secretary*: Mr. J. A. Wallis; *Treasurer*: Mr. G. Franklin; *Committee*: Messrs. G. M. Garraway, A. C. Amos, R. Moule, K. A. Priddey (resigned) and T. D. Jones (co-opted).

The deduction-from-pay scheme was successfully introduced during the past year. The present membership is 154. J.A.W.

#### Dundee Centre

At the annual general meeting of the Dundee Centre held on 25 April, the following officers were elected for the 1963-64 session: *Chairman*: Mr. R. L. Tapping; *Vice-Chairman*: Mr. D. L. Miller; *Secretary*: Mr. R. T. Lumsden; *Treasurer*: Mr. R. B. Duncan; *Committee*: Messrs. Deuchans, Mackie, Smith, Fraser and Beatlie; *Auditors*: Messrs. Lamb and Summers.

It is hoped that our widely varied program for the winter session will attract greater numbers to our meetings and visits.

The first date to note was 21 September when a party of 41 members and friends visited the Grampian television studios and the Girdle Ness lighthouse at Aberdeen. These two visits proved to be most interesting and instructive—the weather was good and a thoroughly enjoyable day was had by all.

The other activities that have been held are briefly as follows:

1 October: "What Does the Other Man Do?"—lectures by heads of Divisions on the functions of the various Divisions in the Telephone Area.

7 November: "The Stock Exchange," Mr. A. O. Spiers, from the Scottish Stock Exchange Publicity Committee.

28 November: Visit to a sugar factory at Cupar, Fife.

17 December: "The Kariba Story," a film in Technicolour prepared by the Federal Power Board of Nigeria and Nyasaland, showing the construction of the Kariba Dam.

The remainder of the program is as follows:

17 February: Visit to Morphy Richards (Astral), Ltd.

11 March: "Tay Road Bridge"; Mr. R. H. Taylor discusses the project.

April: Annual general meeting.

It is hoped that a visit to the new Tay tidal model will be possible in January. R.T.L.

#### Glasgow Centre

Our 1962-63 session opened with a swing when a party of our members, wives and friends visited the Edinburgh Tattoo.

Other talks and visits throughout the remainder of the 1962-63 session were as follows:

3 October: "Telephone Exchanges—What Lies Ahead," by Mr. C. E. Woolley, Training Branch, Engineering Department.

25 October: "Polythene and Plastic Sheathed Cables," by Mr. J. M. Tait, Regional Office, Edinburgh.

15 November: Visit to Scottish Cables, Ltd., Renfrew.

6 December: "What Does the Other Man Do?" by heads of Divisions in the Glasgow Area.

16 January: "The Kariba Story," a film describing the construction of the Kariba Dam.

19 February: "Microwave Links," by Mr. W. N. Shannon, Dumfries.

25 March: Visit to the Department of Scientific and Industrial Research at East Kilbride.

3 April: "Appraisements and Promotions," by Mr. A. H. C. Knox, Chief Regional Engineer, Home Counties Region.

19 April: Annual general meeting.

The film of the Kariba Dam was exceptionally well attended and it can be recommended to other centres for future programs. Attendances at talks and visits were good, with a special mention of the talk by Mr. Knox when we welcomed many visitors from other Divisions.

Since the previous session, our membership has increased from 200 to 370 members due to a campaign by office bearers and the committee. It would be a miracle indeed to expect such a number at each meeting, but the added membership has helped to increase the attendances at meetings.

The winter program for 1963-64, which is now partly completed and which we hope will attract even more new members, is as follows:

10 October: "The Clerke's Tale" (with apologies to Chaucer), by Mr. R. Chivers, Chief Clerk, Glasgow.

30 October: "Modern Astronomy," by Mr. R. B. Hunter, Glasgow University.

19 November: Visit to the Rootes Group car factory, Linwood.

12 December: Films by Shell-Mex and B.P., Ltd.

22 January: "Character Recognition," a lecture on postal mechanization, by Dr. A. M. Coombs, Research Branch, Engineering Department.

13 February: "S.T.D. in the Glasgow Telephone Area," by Mr. M. B. Cantley, Glasgow.

4 March: Visit to the S.T.D. switching centre, Glasgow.

1 April: "Hi-Fi," a lecture and demonstration.

24 April: Annual general meeting.

23 May: Visit to Chapelcross atomic power station.

*Continued on page 297*

# Staff Changes

## Promotions

| Name   | Region, etc.            | Date    | Name  | Region, etc.            | Date     |
|--|-------------------------|---------|---|-------------------------|----------|
| <i>Assistant Staff Engineer to Staff Engineer</i>            |                         |         | <i>Assistant Engineer (Open Competition)</i>    |                         |          |
| Webber, F. W. J.   | E.-in-C.O.              | 1.8.63  | Dyson, R.                                       | E.-in-C.O.              | 20.8.62  |
| <i>Senior Executive Engineer to Assistant Staff Engineer</i> |                         |         | Whetter, J.                                     | E.-in-C.O.              | 28.8.62  |
| Croft, E.  | E.-in-C.O.              | 16.7.63 | Armstrong, R. H.                                | E.-in-C.O.              | 28.8.62  |
| Gould, B. B.   | E.-in-C.O.              | 13.8.63 | Tollman, B. R.                                  | E.-in-C.O.              | 28.8.62  |
| Forster, A. E. T.  | E.-in-C.O.              | 23.8.63 | Nesbitt, T. J.                                  | E.-in-C.O.              | 28.8.62  |
| (in absentia)  |                         |         | Missen, G. A. O.                                | E.-in-C.O.              | 28.8.62  |
| Barnard, A. J.   | E.-in-C.O.              | 2.9.63  | Jordan, H. J.                                   | E.-in-C.O.              | 27.11.62 |
| Thomas, J. F. P.   | E.-in-C.O.              | 20.9.63 | Box, J. H.                                      | E.-in-C.O.              | 27.11.62 |
| <i>Area Engineer to Regional Engineer</i>                    |                         |         | Green, L. A.                                    | E.-in-C.O.              | 27.11.62 |
| Lunn, G. R.  | Scot. to N.W. Reg.      | 2.9.63  | Boylan, J. A.                                   | E.-in-C.O.              | 27.11.62 |
| Glass, V. G.   | N.W. Reg. to S.W. Reg.  | 9.9.63  | Williams, M. D. P.                              | E.-in-C.O.              | 27.11.62 |
| <i>Area Engineer to Deputy Telephone Manager</i>             |                         |         | Hills, A. M. D.                                 | E.-in-C.O.              | 31.12.62 |
| Broadhurst, F.   | N.W. Reg.               | 31.7.63 | Eden, A. J.                                     | E.-in-C.O.              | 27.11.62 |
| <i>Executive Engineer to Area Engineer</i>                   |                         |         | Milton, P. V.                                   | E.-in-C.O.              | 27.11.62 |
| Officer, J. E.   | Mid. Reg. to W.B.C.     | 26.8.63 | Sumner, D. J.                                   | E.-in-C.O.              | 27.11.62 |
| Wooding, W. J.   | L.T. Reg.               | 30.8.63 | Haywood, D. A.                                  | E.-in-C.O.              | 27.11.62 |
| McEachan, J.   | Scot. to N.I.           | 16.9.63 | Newman, W. J.                                   | E.-in-C.O.              | 27.11.62 |
| <i>Executive Engineer to Power Engineer</i>                  |                         |         | Mackirdy, J. M.                                 | E.-in-C.O.              | 24.6.63  |
| Pearce, H. J.  | L.T. Reg. to H.C. Reg.  | 12.8.63 | Brett, M. R.                                    | E.-in-C.O.              | 2.9.63   |
| <i>Executive Engineer to Senior Executive Engineer</i>       |                         |         | Sephton, J. E.                                  | E.-in-C.O.              | 27.8.63  |
| Hatton, G.   | E.-in-C.O.              | 1.7.63  | Brown, D. J. O.                                 | E.-in-C.O.              | 27.8.63  |
| Maurer, C. J.  | E.-in-C.O.              | 1.7.63  | Ellis, A. H.                                    | E.-in-C.O.              | 27.8.63  |
| Sheppard, S. H.  | E.-in-C.O.              | 1.7.63  | Taylor, A.                                      | E.-in-C.O.              | 27.8.63  |
| Morris, K. W.  | Mid. Reg. to E.-in-C.O. | 31.7.63 | <i>Assistant Engineer (Limited Competition)</i> |                         |          |
| Clarke, H.   | E.-in-C.O.              | 1.8.63  | Hornsby, W. J.                                  | N.E. Reg. to E.-in-C.O. | 13.5.63  |
| Hornsby, H. C.   | H.C. Reg. to E.-in-C.O. | 13.8.63 | Chave, G.                                       | H.C. Reg. to E.-in-C.O. | 13.5.63  |
| Heptinstall, D. L.   | E.-in-C.O.              | 22.8.63 | Priddey, K. A.                                  | S.W. Reg. to E.-in-C.O. | 13.5.63  |
| Beardmore, A. F.   | E.-in-C.O.              | 2.9.63  | Thomas, J. D.                                   | N.E. Reg. to E.-in-C.O. | 13.5.63  |
| Gaukroger, J.  | N.W. Reg.               | 16.9.63 | Dingle, B. D.                                   | L.T. Reg. to E.-in-C.O. | 4.6.63   |
| Blanchard, D. T.   | E.-in-C.O.              | 23.9.63 | Rogers, A. J.                                   | S.W. Reg. to E.-in-C.O. | 13.5.63  |
| Roberts, E.  | W.B.C. to E.-in-C.O.    | 30.9.63 | Loneragan, J. L.                                | L.T. Reg. to E.-in-C.O. | 4.6.63   |
| <i>Executive Engineer (Open Competition)</i>                 |                         |         | Barton, D. S.                                   | L.P. Reg. to E.-in-C.O. | 13.5.63  |
| Luetchford, J. C.  | E.-in-C.O.              | 1.7.63  | Wall, C. I.                                     | S.W. Reg.               | 17.6.63  |
| Price, C. D. E.  | E.-in-C.O.              | 1.7.63  | Bayfield, R.                                    | H.C. Reg. to E.-in-C.O. | 15.7.63  |
| Lines, P. D.   | E.-in-C.O.              | 1.7.63  | Andrew, G. I.                                   | S.W. Reg. to E.-in-C.O. | 13.5.63  |
| Maul, D.   | E.-in-C.O.              | 1.7.63  | Loxley, B. R.                                   | H.C. Reg. to E.-in-C.O. | 13.5.63  |
| Lonnen, K. W. J.   | E.-in-C.O.              | 1.7.63  | White, D. E.                                    | L.T. Reg. to E.-in-C.O. | 17.6.63  |
| Denning, S. F.   | E.-in-C.O.              | 8.7.63  | Smith, M. A.                                    | L.T. Reg. to E.-in-C.O. | 15.7.63  |
| Blake, W. S.   | E.-in-C.O.              | 6.8.63  | Hughes, C. G.                                   | W.B.C.                  | 13.5.63  |
| Smith, T. M.   | E.-in-C.O.              | 26.8.63 | Dudley, D. K.                                   | Mid. Reg. to E.-in-C.O. | 13.5.63  |
| Morse, A. G. D.  | E.-in-C.O.              | 27.8.63 | Smith, R. S.                                    | N.W. Reg. to E.-in-C.O. | 13.5.63  |
| Hill, B. E.  | E.-in-C.O.              | 29.8.63 | Skarbinski, L. T.                               | Mid. Reg. to E.-in-C.O. | 13.5.63  |
| Feltham, D. R.   | E.-in-C.O.              | 30.8.63 | Roberts, P.                                     | N.E. Reg.               | 13.5.63  |
| Harris, A. S.  | E.-in-C.O.              | 10.9.63 | Jenkins, D. F.                                  | S.W. Reg.               | 13.5.63  |
| Barry, D. W.   | E.-in-C.O.              | 10.9.63 | Eunson, R. F.                                   | W.B.C.                  | 13.5.63  |
| Morse, M. J.   | E.-in-C.O.              | 30.9.63 | Dawson, W.                                      | N.E. Reg. to E.-in-C.O. | 17.6.63  |
| <i>Assistant Engineer to Executive Engineer</i>              |                         |         | Dickinson, J. P.                                | N.E. Reg. to E.-in-C.O. | 4.6.63   |
| Clayton, A. D.   | S.W. Reg. to W.B.C.     | 1.7.63  | Ireland, J. M.                                  | N.W. Reg. to E.-in-C.O. | 1.7.63   |
| Cohen, A.  | S.W. Reg. to Mid. Reg.  | 1.7.63  | Patmore, J. H. P.                               | L.T. Reg. to E.-in-C.O. | 4.6.63   |
| Hancock, L.  | N.W. Reg.               | 1.7.63  | McLeer, W. E.                                   | N.I.                    | 4.6.63   |
| Maile, J. L.   | E.-in-C.O.              | 4.7.63  | Pyle, J. C.                                     | L.T. Reg. to E.-in-C.O. | 4.6.63   |
| Thomas, G. W.  | E.-in-C.O.              | 4.7.63  | Rossiter, D. G.                                 | S.W. Reg. to Mid. Reg.  | 17.6.63  |
| Edmonds, C. A.   | L.T. Reg.               | 11.7.63 | Hamling, J. R.                                  | H.C. Reg.               | 4.6.63   |
| Bree, W.   | E.-in-C.O.              | 12.7.63 | Taylor, R. W.                                   | E.-in-C.O.              | 4.6.63   |
| Angerson, R. M.  | S.W. Reg. to E.-in-C.O. | 22.7.63 | Edgerton, D. J.                                 | L.T. Reg.               | 4.6.63   |
| Sansbury, K. J.  | Mid. Reg. to N.W. Reg.  | 22.7.63 | Withey, B. A.                                   | L.T. Reg. to E.-in-C.O. | 4.6.63   |
| Jessop, E. C.  | H.C. Reg. to S.W. Reg.  | 2.9.63  | Woolven, A. J. W.                               | E.-in-C.O.              | 4.6.63   |
| Double, D. G.  | Mid. Reg.               | 12.8.63 | Harris, J. G.                                   | N.E. Reg. to E.-in-C.O. | 4.6.63   |
| Marmont, A. D.   | Mid. Reg.               | 19.8.63 | Taman, D. L.                                    | N.E. Reg.               | 1.7.63   |
| Johnson, J. H. M.  | E.-in-C.O. to E.T.E.    | 9.9.63  | Bawden, H. C.                                   | H.C. Reg.               | 4.6.63   |
| Squire, R. W.  | H.C. Reg. to L.T. Reg.  | 9.9.63  | Harris, B. C.                                   | N.W. Reg. to E.-in-C.O. | 4.6.63   |
| Rutter, N. J. S.   | H.C. Reg. to E.-in-C.O. | 23.9.63 | Flynn, A. W.                                    | N.W. Reg. to E.-in-C.O. | 4.6.63   |
| Self, C. P.  | H.C. Reg. to E.-in-C.O. | 23.9.63 | Stevens, W. H.                                  | N.E. Reg. to E.-in-C.O. | 4.6.63   |
| Sheldrake, R. J.   | H.C. Reg. to S.W. Reg.  | 30.9.63 | Dutton, R.                                      | N.E. Reg. to E.-in-C.O. | 4.6.63   |
| Hill, J. D.  | E.-in-C.O.              | 25.9.63 | Inman, B. E.                                    | E.T.E. to E.-in-C.O.    | 17.6.63  |
| Baynham, L. J.   | Mid. Reg.               | 26.9.63 | Crosby, G. W.                                   | L.T. Reg. to E.-in-C.O. | 17.6.63  |
|  |                         |         | Pitman, A.                                      | N.W. Reg.               | 17.6.63  |
|  |                         |         | Walker, J. R. V.                                | L.T. Reg.               | 17.6.63  |
|  |                         |         | Morrison, R. J.                                 | N.I.                    | 17.6.63  |
|  |                         |         | Margerison, R.                                  | N.E. Reg.               | 17.6.63  |
|  |                         |         | Lawrence, A. J.                                 | L.T. Reg. to E.-in-C.O. | 17.6.63  |
|  |                         |         | Martin, T. L.                                   | Scot.                   | 17.6.63  |
|  |                         |         | Russell, M.                                     | H.C. Reg. to E.-in-C.O. | 1.7.63   |

Promotions—continued

| Name  | Region, etc.                    | Date    | Name  | Region, etc.                    | Date    |
|---|---------------------------------|---------|---|---------------------------------|---------|
| <i>Assistant Engineer (Limited Competition)—continued</i> |                                 |         | <i>Technical Officer to Assistant Engineer—continued</i>    |                                 |         |
| Bennett, J. P. . . . .                                    | L.T. Reg. to E.-in-C.O. . . . . | 4.6.63  | Gibbs, R. W. . . . .  | L.T. Reg. . . . .               | 3.9.63  |
| Blake, P. W. . . . .                                      | E.-in-C.O. . . . .              | 17.6.63 | Donovan, D. J. . . . .                                      | L.T. Reg. . . . .               | 3.9.63  |
| Bradfield, A. J. . . . .                                  | E.-in-C.O. . . . .              | 13.5.63 | Skeats, J. H. . . . .                                       | L.T. Reg. . . . .               | 3.9.63  |
| Miller, J. R. . . . .                                     | E.-in-C.O. . . . .              | 13.5.63 | Mackay, D. W. . . . .                                       | Mid. Reg. . . . .               | 25.9.63 |
| George, F. R. . . . .                                     | H.C. Reg. to E.-in-C.O. . . . . | 17.6.63 | <i>Draughtsman to Assistant Engineer</i>                    |                                 |         |
| Taylor, G. H. . . . .                                     | E.T.E. to E.-in-C.O. . . . .    | 1.7.63  | Briggs, P. J. . . . .                                       | Mid. Reg. . . . .               | 9.7.63  |
| Haddock, G. A. . . . .                                    | E.-in-C.O. . . . .              | 17.6.63 | <i>Technical Officer to Inspector</i>                       |                                 |         |
| Phillips, K. H. C. . . . .                                | S.W. Reg. to E.-in-C.O. . . . . | 1.7.63  | Roberts, H. C. . . . .                                      | H.C. Reg. . . . .               | 1.7.63  |
| Teven, R. J. . . . .                                      | E.T.E. to E.-in-C.O. . . . .    | 1.7.63  | Gardner, A. H. W. . . . .                                   | L.T. Reg. . . . .               | 8.7.63  |
| Lawrence, A. R. . . . .                                   | E.-in-C.O. . . . .              | 27.5.63 | Henderson, A. C. . . . .                                    | Scot. . . . .                   | 22.7.63 |
| McLean, J. M. . . . .                                     | E.-in-C.O. . . . .              | 13.5.63 | Downie, W. . . . .  | Scot. . . . .                   | 9.9.63  |
| Pettit, A. G. R. . . . .                                  | H.C. Reg. to E.-in-C.O. . . . . | 1.7.63  | Moors, J. J. S. . . . .                                     | L.T. Reg. . . . .               | 3.9.63  |
| Anderson, P. C. . . . .                                   | E.-in-C.O. . . . .              | 1.7.63  | Graham, W. . . . .  | L.T. Reg. . . . .               | 3.9.63  |
| Curtis, A. J. . . . .                                     | L.T. Reg. . . . .               | 1.7.63  | Simons, H. J. . . . .                                       | L.T. Reg. . . . .               | 3.9.63  |
| Baylis, H. G. . . . .                                     | N.E. Reg. to Mid. Reg. . . . .  | 1.7.63  | Smith, D. E. . . . .  | L.T. Reg. . . . .               | 3.9.63  |
| Gordon, W. G. . . . .                                     | Scot. to N.W. Reg. . . . .      | 1.7.63  | <i>Technician I to Inspector</i>                            |                                 |         |
| Pœbles, A. D. . . . .                                     | Scot. to Mid. Reg. . . . .      | 1.7.63  | Goodship, D. . . . .  | N.W. Reg. . . . .               | 1.7.63  |
| Bell, P. G. . . . .                                       | N.W. Reg. . . . .               | 1.7.63  | Bridgeman, J. H. . . . .                                    | N.W. Reg. . . . .               | 29.7.63 |
| Gorman, F. W. . . . .                                     | L.T. Reg. to E.-in-C.O. . . . . | 1.7.63  | Ferguson, J. . . . .  | Scot. . . . .                   | 4.7.63  |
| Jones, M. E. . . . .                                      | N.W. Reg. to E.-in-C.O. . . . . | 1.7.63  | Richardson, H. . . . .                                      | N.E. Reg. . . . .               | 12.8.63 |
| Fowler, E. . . . .  | Mid. Reg. . . . .               | 1.7.63  | Gilbert, G. . . . .   | Mid. Reg. . . . .               | 16.8.63 |
| Warwick, G. B. . . . .                                    | W.B.C. to Mid. Reg. . . . .     | 1.7.63  | Cooper, R. C. . . . .                                       | S.W. Reg. . . . .               | 19.8.63 |
| Gillford, R. S. . . . .                                   | Mid. Reg. to E.-in-C.O. . . . . | 1.7.63  | Thomas, A. J. . . . .                                       | S.W. Reg. . . . .               | 26.8.63 |
| King, P. R. G. . . . .                                    | S.W. Reg. to Mid. Reg. . . . .  | 1.7.63  | Stephens, J. A. . . . .                                     | S.W. Reg. . . . .               | 19.8.63 |
| Odell, R. F. . . . .                                      | L.T. Reg. to E.-in-C.O. . . . . | 4.6.63  | Conroy, J. P. . . . .                                       | N.W. Reg. . . . .               | 30.8.63 |
| <i>Inspector to Assistant Engineer</i>                    |                                 |         | Tetlow, H. . . . .  | N.W. Reg. . . . .               | 30.8.63 |
| Drake, E. S. . . . .                                      | S.W. Reg. . . . .               | 15.7.63 | Whittaker, E. R. . . . .                                    | N.W. Reg. . . . .               | 30.8.63 |
| Bredemeier, F. M. . . . .                                 | L.T. Reg. . . . .               | 5.7.63  | Parsons, O. B. E. . . . .                                   | S.W. Reg. . . . .               | 3.9.63  |
| Nash, J. T. R. . . . .                                    | L.T. Reg. . . . .               | 5.7.63  | Every, W. J. . . . .  | S.W. Reg. . . . .               | 2.9.63  |
| Herbert, E. . . . .                                       | L.T. Reg. . . . .               | 5.7.63  | Robinson, W. A. . . . .                                     | N.E. Reg. . . . .               | 19.8.63 |
| Blizard, A. . . . .                                       | N.E. Reg. . . . .               | 9.7.63  | Major, L. . . . .   | N.E. Reg. . . . .               | 10.9.63 |
| Hudson, H. . . . .  | N.E. Reg. . . . .               | 9.7.63  | Triggs, J. . . . .  | L.T. Reg. . . . .               | 3.9.63  |
| Edge, S. G. L. . . . .                                    | W.B.C. . . . .                  | 12.8.63 | Nielson, H. V. . . . .                                      | L.T. Reg. . . . .               | 3.9.63  |
| Bœchey, L. C. . . . .                                     | N.W. Reg. . . . .               | 8.8.63  | Cross, J. . . . .   | N.W. Reg. . . . .               | 16.9.63 |
| Deaves, H. A. . . . .                                     | L.T. Reg. . . . .               | 3.9.63  | Gallagher, R. . . . .                                       | N.W. Reg. . . . .               | 9.9.63  |
| Parker, E. C. . . . .                                     | L.T. Reg. . . . .               | 3.9.63  | Ashworth, D. E. . . . .                                     | N.W. Reg. . . . .               | 9.9.63  |
| Clark, E. J. . . . .                                      | L.T. Reg. . . . .               | 3.9.63  | Plenderleith, J. . . . .                                    | N.W. Reg. . . . .               | 9.9.63  |
| Ross, W. . . . .  | L.T. Reg. . . . .               | 3.9.63  | <i>Senior Scientific Officer (Open Competition)</i>         |                                 |         |
| Marchant, D. L. . . . .                                   | N.E. Reg. . . . .               | 6.9.63  | Butler, D. S. . . . .                                       | E.-in-C.O. . . . .              | 8.7.63  |
| <i>Technical Officer to Assistant Engineer</i>            |                                 |         | Stanley, I. W. . . . .                                      | E.-in-C.O. . . . .              | 23.9.63 |
| Black, J. H. . . . .                                      | Scot. . . . .                   | 1.7.63  | <i>Experimental Officer (Open Competition)</i>              |                                 |         |
| Eaton, R. . . . .   | Mid. Reg. . . . .               | 9.7.63  | Molloy, J. . . . .  | E.-in-C.O. . . . .              | 30.9.63 |
| Plenderleith, D. M. . . . .                               | Scot. . . . .                   | 15.7.63 | <i>Scientific Officer (Open Competition)</i>                |                                 |         |
| Ashton, A. . . . .  | N.W. Reg. . . . .               | 24.7.63 | Pilgrim, M. . . . .   | E.-in-C.O. . . . .              | 12.8.63 |
| Hetherington, J. . . . .                                  | W.B.C. . . . .                  | 12.8.63 | <i>Assistant Experimental Officer (Open Competition)</i>    |                                 |         |
| Bell, J. S. . . . .                                       | L.T. Reg. . . . .               | 25.8.63 | Porter, M. A. G. (Miss) . . . . .                           | E.-in-C.O. . . . .              | 2.9.63  |
| Hollingsworth, G. F. . . . .                              | N.W. Reg. to E.-in-C.O. . . . . | 15.8.63 | <i>Draughtsman to Leading Draughtsman</i>                   |                                 |         |
| Best, D. F. E. . . . .                                    | E.T.E. . . . .                  | 2.8.63  | Vallance, F. J. . . . .                                     | E.-in-C.O. . . . .              | 18.6.63 |
| Holland, D. G. . . . .                                    | E.T.E. . . . .                  | 6.8.63  | Davenport, R. N. . . . .                                    | L.T. Reg. . . . .               | 18.6.63 |
| Hartup, K. W. G. . . . .                                  | Mid. Reg. . . . .               | 16.8.63 | Morley, D. G. . . . .                                       | L.T. Reg. . . . .               | 18.6.63 |
| Miles, A. . . . .   | N.W. Reg. . . . .               | 6.8.63  | Ramsay, A. J. . . . .                                       | L.T. Reg. to E.-in-C.O. . . . . | 18.6.63 |
| Sheridan, H. S. . . . .                                   | N.W. Reg. . . . .               | 12.8.63 | Levy, P. D. . . . .   | L.T. Reg. . . . .               | 18.6.63 |
| Stanier, R. W. . . . .                                    | Mid. Reg. . . . .               | 16.8.63 | Collins, B. V. F. . . . .                                   | L.T. Reg. . . . .               | 18.6.63 |
| Lynch, J. P. . . . .                                      | N.I. . . . .                    | 11.7.63 | Chilton, D. C. L. . . . .                                   | L.P. Reg. . . . .               | 18.6.63 |
| Thomas, M. G. M. . . . .                                  | S.W. Reg. . . . .               | 19.8.63 | Moore, E. W. . . . .  | L.T. Reg. . . . .               | 18.6.63 |
| Vogler, G. T. . . . .                                     | S.W. Reg. . . . .               | 19.8.63 | Nixon, J. F. . . . .  | L.T. Reg. . . . .               | 18.6.63 |
| Finch, R. D. . . . .                                      | S.W. Reg. . . . .               | 7.8.63  | Singleton, S. R. . . . .                                    | L.P. Reg. . . . .               | 18.6.63 |
| Helleur, J. O. . . . .                                    | S.W. Reg. . . . .               | 19.8.63 | Kibbel, D. W. J. . . . .                                    | L.T. Reg. to L.P. Reg. . . . .  | 18.6.63 |
| Allen, R. H. . . . .                                      | S.W. Reg. . . . .               | 19.8.63 | Turner, R. F. . . . .                                       | L.P. Reg. . . . .               | 18.6.63 |
| Clifton, R. E. . . . .                                    | N.E. Reg. . . . .               | 19.8.63 | Levey, E. G. . . . .  | H.C. Reg. . . . .               | 30.7.63 |
| Buckeridge, A. A. . . . .                                 | S.W. Reg. . . . .               | 19.8.63 | Reeves, J. M. . . . .                                       | L.T. Reg. to E.-in-C.O. . . . . | 30.7.63 |
| Hope, D. J. . . . .                                       | Mid. Reg. . . . .               | 16.8.63 | Potter, K. J. B. . . . .                                    | L.T. Reg. to E.-in-C.O. . . . . | 30.7.63 |
| Roden, F. . . . .   | W.B.C. . . . .                  | 29.8.63 | Beattie, L. H. N. . . . .                                   | Scot. . . . .                   | 1.8.63  |
| Wilson, E. G. . . . .                                     | Mid. Reg. . . . .               | 25.9.63 | Lewis, I. . . . .   | L.P. Reg. to E.-in-C.O. . . . . | 1.8.63  |
| Smith, R. J. . . . .                                      | S.W. Reg. . . . .               | 2.9.63  | <i>Higher Executive Officer to Senior Executive Officer</i> |                                 |         |
| Mason, W. . . . .   | Scot. . . . .                   | 3.9.63  | Harmon, D. M. (Miss) . . . . .                              | E.-in-C.O. . . . .              | 2.8.63  |
| Miller, R. L. . . . .                                     | L.T. Reg. . . . .               | 3.9.63  |   |                                 |         |
| Baker, R. D. . . . .                                      | L.T. Reg. . . . .               | 3.9.63  |   |                                 |         |
| Deacon, H. C. . . . .                                     | L.T. Reg. . . . .               | 3.9.63  |   |                                 |         |
| Le Blanc, J. A. S. . . . .                                | L.T. Reg. . . . .               | 3.9.63  |   |                                 |         |
| Church, R. E. D. . . . .                                  | L.T. Reg. . . . .               | 3.9.63  |   |                                 |         |
| Williams, A. . . . .                                      | L.T. Reg. . . . .               | 3.9.63  |   |                                 |         |
| Baker, H. M. . . . .                                      | L.T. Reg. . . . .               | 3.9.63  |   |                                 |         |
| Dungate, D. A. . . . .                                    | L.T. Reg. . . . .               | 3.9.63  |   |                                 |         |



**Retirements and Resignations**

| Name                            | Region, etc.       | Date    | Name                                  | Region, etc.       | Date    |
|---------------------------------|--------------------|---------|---------------------------------------|--------------------|---------|
| <i>Staff Engineer</i>           |                    |         | <i>Assistant Engineer—continued</i>   |                    |         |
| Edwards, J. J. . . . .          | E.-in-C.O. . . . . | 21.9.63 | Scott, C. W. . . . .                  | L.T. Reg. . . . .  | 31.8.63 |
| <i>Assistant Staff Engineer</i> |                    |         | Barker, A. P. . . . .                 | L.T. Reg. . . . .  | 31.8.63 |
| Broadhurst, S. W. . . . .       | E.-in-C.O. . . . . | 16.8.63 | Adamson, R. A. . . . .                | L.T. Reg. . . . .  | 1.5.63  |
| <i>Regional Engineer</i>        |                    |         | <i>(Resigned)</i>                     |                    |         |
| Duff, J. . . . .                | N.W. Reg. . . . .  | 25.8.63 | Platt, S. M. K. <i>(Resigned)</i>     | E.-in-C.O. . . . . | 31.7.63 |
| <i>Area Engineer</i>            |                    |         | Gilbert, A. P. <i>(Resigned)</i>      | E.-in-C.O. . . . . | 31.8.63 |
| Blight, A. . . . .              | L.T. Reg. . . . .  | 8.7.63  | Holt, S. A. . . . .                   | L.T. Reg. . . . .  | 2.9.63  |
| Hopkinson, E. <i>(Resigned)</i> | N.E. Reg. . . . .  | 31.8.63 | Hoy, H. G. . . . .                    | E.T.E. . . . .     | 6.9.63  |
| Coulsdon, J. N. . . . .         | N.W. Reg. . . . .  | 13.9.63 | Tones, C. K. . . . .                  | N.E. Reg. . . . .  | 7.9.63  |
| <i>Executive Engineer</i>       |                    |         | Read, W. A. . . . .                   | S.W. Reg. . . . .  | 19.9.63 |
| Roberts, E. . . . .             | E.-in-C.O. . . . . | 19.7.63 | Evans, J. R. W. . . . .               | E.T.E. . . . .     | 21.9.63 |
| Smith, G. J. . . . .            | N.W. Reg. . . . .  | 29.7.63 | Trippier, F. J. . . . .               | E.-in-C.O. . . . . | 27.9.63 |
| Hatfield, W. H. . . . .         | E.-in-C.O. . . . . | 26.7.63 | Rowbotham, H. B. . . . .              | N.E. Reg. . . . .  | 28.9.63 |
| Luckhurst, J. E. . . . .        | E.T.E. . . . .     | 5.8.63  | Cregan, L. J. . . . .                 | N.W. Reg. . . . .  | 28.9.63 |
| Morris, A. J. . . . .           | E.-in-C.O. . . . . | 4.8.63  | Cliff, J. <i>(Resigned)</i>           | E.-in-C.O. . . . . | 13.9.63 |
| Rutland, G. A. . . . .          | S.W. Reg. . . . .  | 2.8.63  | Pendlebury, N. H. . . . .             | E.-in-C.O. . . . . | 22.9.63 |
| Blois, W. H. . . . .            | E.-in-C.O. . . . . | 31.8.63 | <i>(Resigned)</i>                     |                    |         |
| Smart, H. W. . . . .            | W.B.C. . . . .     | 31.8.63 | Evans, D. T. <i>(Resigned)</i>        | L.T. Reg. . . . .  | 30.9.63 |
| Willson, J. C. . . . .          | E.-in-C.O. . . . . | 21.9.63 | Nolan, A. V. <i>(Resigned)</i>        | N.W. Reg. . . . .  | 30.9.63 |
| Williams, H. <i>(Resigned)</i>  | E.-in-C.O. . . . . | 27.9.63 | <i>Inspector</i>                      |                    |         |
| <i>Assistant Engineer</i>       |                    |         | Medford, A. O. . . . .                | N.W. Reg. . . . .  | 12.7.63 |
| Curtis, E. W. . . . .           | N.E. Reg. . . . .  | 1.7.63  | Lewis, T. R. H. . . . .               | L.T. Reg. . . . .  | 22.7.63 |
| Barrell, J. . . . .             | N.E. Reg. . . . .  | 22.7.63 | Rees, H. T. H. . . . .                | W.B.C. . . . .     | 25.7.63 |
| Poulton, A. H. . . . .          | L.T. Reg. . . . .  | 24.7.63 | Davidson, A. M. . . . .               | Scot. . . . .      | 29.5.63 |
| Durkan, J. P. <i>(Resigned)</i> | N.E. Reg. . . . .  | 20.7.63 | McCubbin, I. . . . .                  | Scot. . . . .      | 18.7.63 |
| Nickson, J. . . . .             | L.P. Reg. . . . .  | 8.6.63  | Ritchie, D. . . . .                   | Scot. . . . .      | 30.7.63 |
| Mitchell, H. B. . . . .         | E.-in-C.O. . . . . | 9.7.63  | McRae, J. . . . .                     | Scot. . . . .      | 10.8.63 |
| Stansfield, R. . . . .          | N.W. Reg. . . . .  | 1.8.63  | Olley, S. A. . . . .                  | L.T. Reg. . . . .  | 16.8.63 |
| Small, W. B. . . . .            | N.W. Reg. . . . .  | 5.8.63  | Lever, F. A. . . . .                  | L.T. Reg. . . . .  | 17.8.63 |
| Long, E. . . . .                | N.W. Reg. . . . .  | 9.8.63  | Oxley, A. E. . . . .                  | Scot. . . . .      | 21.8.63 |
| Gardner, D. H. . . . .          | H.C. Reg. . . . .  | 13.8.63 | Russell, R. . . . .                   | Mid. Reg. . . . .  | 26.8.63 |
| Cox, H. W. J. . . . .           | L.T. Reg. . . . .  | 14.8.63 | Elford, R. . . . .                    | S.W. Reg. . . . .  | 10.8.63 |
| Loveland, F. T. . . . .         | L.T. Reg. . . . .  | 31.8.63 | Kelly, F. W. . . . .                  | N.W. Reg. . . . .  | 20.9.63 |
| Allen, G. H. . . . .            | S.W. Reg. . . . .  | 31.8.63 | <i>Motor Transport Officer III</i>    |                    |         |
| Smith, H. B. . . . .            | Mid. Reg. . . . .  | 31.8.63 | Cadge, E. R. . . . .                  | Mid. Reg. . . . .  | 19.7.63 |
|                                 |                    |         | <i>Executive Officer</i>              |                    |         |
|                                 |                    |         | Tolley, D. M. <i>(Miss)</i> . . . . . | E.-in-C.O. . . . . | 31.7.63 |

**Transfers**

| Name                             | Region, etc.                               | Date    | Name                                | Region, etc.                                 | Date    |
|----------------------------------|--|---------|-------------------------------------|--|---------|
| <i>Staff Engineer</i>            |  |         | <i>Executive Engineer—continued</i> |  |         |
| Francis, H. E. . . . .           | E.-in-C.O. to L.T. Reg. . . . .            | 19.8.63 | Holmes, A. C. . . . .               | E.-in-C.O. to L.T. Reg. . . . .              | 26.8.63 |
| <i>Chief Factories Engineer</i>  |  |         | Wherry, A. B. . . . .               | E.-in-C.O. to Hong Kong                      | 24.9.63 |
| Urban, T. F. A. . . . .          | Factories Department to E.-in-C.O. . . . . | 1.7.63  | Harris, B. V. . . . .               | E.-in-C.O. to Foreign Office                 | 2.9.63  |
| <i>Senior Executive Engineer</i> |  |         | <i>Assistant Engineer</i>           |  |         |
| Irwin, A. . . . .                | Nigeria to E.-in-C.O. . . . .              | 26.8.63 | French, T. W. . . . .               | L.T. Reg. to E.-in-C.O. . . . .              | 15.7.63 |
| Breary, D. . . . .               | Approved Employment to L.T. Reg. . . . .   | 9.9.63  | Cliff, J. . . . .                   | Nigeria to E.-in-C.O. . . . .                | 29.7.63 |
| Davis, E. . . . .                | E.-in-C.O. to L.T. Reg. . . . .            | 19.8.63 | Hefford, P. G. . . . .              | E.-in-C.O. to Ministry of Aviation . . . . . | 8.7.63  |
| Morgan, T. J. . . . .            | L.T. Reg. to Hong Kong . . . . .           | 24.9.63 | Kitsell, J. H. . . . .              | E.-in-C.O. to S.H.A.P.E. . . . .             | 22.7.63 |
| <i>Executive Engineer</i>        |  |         | Millard, D. R. . . . .              | E.-in-C.O. to Foreign Office                 | 1.8.63  |
| Godfrey, S. W. . . . .           | E.-in-C.O. to L.P. Reg. . . . .            | 1.7.63  | Hughes, L. E. . . . .               | L.T. Reg. to E.-in-C.O. . . . .              | 22.8.63 |
| Wilson, A. A. . . . .            | Approved Employment to Scot. . . . .       | 1.7.63  | Gorard, S. R. . . . .               | E.-in-C.O. to H.C. Reg. . . . .              | 9.9.63  |
| Larder, D. A. . . . .            | E.-in-C.O. to Fiji . . . . .               | 28.8.63 | Dunn, W. A. J. . . . .              | E.-in-C.O. to S.W. Reg. . . . .              | 30.9.63 |
|                                  |  |         | <i>Principal Scientific Officer</i> |  |         |
|                                  |  |         | Thomson, W. E. . . . .              | E.-in-C.O. to L.T. Reg. . . . .              | 17.8.63 |

# The Post Office Electrical Engineers' Journal

Volume 56, April 1963–January 1964

## INDEX

|  | PAGE<br>NO.   |   | PAGE<br>NO. |
|--|---------------|---|-------------|
| <b>A</b>   |               |   |             |
| Anglo-Canadian Transatlantic Telephone Cable (CANTAT): Cable Development, Design and Manufacture   | 82            | Carter, F. C. (Retirement) ... ..   | 205         |
| Anglo-Canadian Transatlantic Telephone Cable (CANTAT): Cable-Laying Gear ... ..  | 91            | CHAPMAN, K. J., and CLARKE, E. F. S. Anglo-Canadian Transatlantic Telephone Cable (CANTAT): Cable-Laying Gear ... ..                                      | 91          |
| Anglo-Canadian Transatlantic Telephone Cable (CANTAT): Laying the North Atlantic Link ... ..   | 99            | CHILD, M. R., LEVETT, A., and DAGLISH, H. N. The Helium System of the Maser Installation at Goonhilly Radio Station ... ..                                | 29          |
| Anglo-Canadian Transatlantic Telephone Cable (CANTAT): Submerged Repeaters, Equalizers and Associated Terminal Equipment ... ..                    | 76            | CLARKE, E. F. S., and CHAPMAN, K. J. Anglo-Canadian Transatlantic Telephone Cable (CANTAT): Cable-Laying Gear ... ..                                      | 91          |
| Anglo-Canadian Transatlantic Telephone Cable System (CANTAT), The ... ..   | 73            | CLARKE, E. F. S., JONES, F., and BROCKBANK, R. A. Anglo-Canadian Transatlantic Telephone Cable (CANTAT): Cable Development, Design and Manufacture ... .. | 82          |
| Associate Section Notes ... ..   | 62, 141, 216, | CLINCH, C. E. E., and STENSON, D. W. Housing of Repeater Equipment Underground ... ..   | 158         |
| Audio Equipment, Transistor-Type 4-wire ... ..   | 288           | Coleman, W. L. A. (Appointment as Chief Regional Engineer) ... ..   | 205         |
| Automatic Switching of Inland Carrier-Link Sections of Transatlantic Telephone Cable Systems ... ..  | 40            | Communications in the Public Service of the United Kingdom ... ..   | 223         |
|  | 237           | Computer—Its Use in Research, The Post Office Engineering Department's ... ..   | 133         |
| <b>B</b>   |               |   |             |
| BANHAM, H., and HILLEN, C. F. J. The Use of Magnetic Cores in Logical and Memory Circuits ... ..   | 46            | Conference, Geneva, 7 October–8 November, 1963, The Extraordinary Administrative Radio ... ..   | 251         |
| Barker, H. (Appointment as Staff Engineer) ... ..  | 209           | Congestion Announcer, An Improved ... ..  | 36          |
| Barker, P. L. (Retirement) ... ..  | 210           | Costing Study, Exchange Line ... ..   | 186         |
| BATES, O. R. (Capt.), and BROCKBANK, R. A. Anglo-Canadian Transatlantic Telephone Cable (CANTAT): Laying the North Atlantic Link ... ..            | 99            | CRAFT, Joan L. Standardization and Control of Colour for the 700-Type Telephone ... ..  | 247         |
| BENNETT, G. H., and BOLTON, L. J. Transistor-Type 4-Wire Audio Equipment ... ..  | 40            | Craggs, J. F., WALTER, J. R., and KEEP, J. F. Pressurization of Telecommunication Cables (Parts 2 and 3) ... ..   | 25, 129     |
| BEST, F. L. A Small Hand-Operated Hydraulic Thrust-Borer ... ..  | 192           | CROISDALE, A. C., and ROBINS, J. M. An Electronic Telegraph Buffer Store Using a Magnetic Drum ... ..   | 262         |
| "Better Opportunities in Technical Education" ... ..   | 13            | <b>D</b>  |             |
| Blair, D. C. (Appointment as Chief Regional Engineer)  | 211           | DAGLISH, H. N., CHILD, M. R., and LEVETT, A. The Helium System of the Maser Installation at Goonhilly Radio Station ... ..                                | 29          |
| BOLTON, L. J., and BENNETT, G. H. Transistor-Type 4-Wire Audio Equipment ... ..  | 40            | DAVEY, L. R. New Key-and-Lamp Desk Unit ... ..  | 156         |
| Booth, C. F. (Capt.) (Retirement) ... ..   | 55            | Decade of Growth in the Trunk Telephone Network, 1952–62, A ... ..  | 177         |
| BORROFF, EILEEN N. Preservation of Cable Drums ... ..  | 44            | Design and Technology of Silicon Planar Transistors   | 239         |
| BROCKBANK, R. A., and BATES, O. R. (Capt.) Anglo-Canadian Transatlantic Telephone Cable (CANTAT): Laying the North Atlantic Link ... ..            | 99            | Dialling into the United Kingdom Telex Network over Long-Distance Radio Circuits ... ..   | 162         |
| BROCKBANK, R. A., CLARKE, E. F. S., and JONES, F. Anglo-Canadian Transatlantic Telephone Cable (CANTAT): Cable Development, Design and Manufacture | 82            | Ducts, The Manufacture of Earthenware ... ..  | 231         |
| BROOKS, H. P., and LIGHT, R. A. M. Pressurization of Telecommunication Cables (Part 4) ... ..  | 170           | <b>E</b>  |             |
| BUFFIN, J. D., and ENDERSBY, J. C. Temperature Tests for Transmission Equipment Located in Footway Joint-Boxes ... ..                              | 160           | Education", "Better Opportunities in Technical ... ..   | 13          |
| <b>C</b>   |               |   |             |
| Cable (CANTAT): Cable Development, Design and Manufacture, Anglo-Canadian Transatlantic Telephone ... ..   | 82            | Edwards, J. J. (Retirement) ... ..  | 283         |
| Cable (CANTAT): Cable-Laying Gear, Anglo-Canadian Transatlantic Telephone ... ..   | 91            | Effect on Service During 1962–63 of the Pressurization of the Trunk Cable Network ... ..  | 176         |
| Cable (CANTAT): Laying the North Atlantic Link, Anglo-Canadian Transatlantic Telephone ... ..  | 99            | Electric Underfloor Heating ... ..  | 181         |
| Cable (CANTAT): Submerged Repeaters, Equalizers and Associated Terminal Equipment, Anglo-Canadian Transatlantic Telephone ... ..                   | 76            | Electronic Calculator, A Simple Sum-of-Squares ... ..   | 6           |
| Cable Drums, Preservation of ... ..  | 44            | Electronic Director Using Magnetic-Core Circuits, An Experimental 3-Digit ... ..  | 255         |
| Cable Network, The Effect on Service During 1962–63 of the Pressurization of the Trunk ... ..  | 176           | Electronic Telegraph Buffer Store Using a Magnetic Drum, An ... ..  | 262         |
| Cable, Polythene-Sheathed Paper-Core Unit Twin (S)   | 32            | ELLEN, L. W. A Simple Sum-of-Squares Electronic Calculator ... ..   | 6           |
| Cable System (CANTAT): The Anglo-Canadian Transatlantic Telephone ... ..   | 73            | ELLIS, W. A. Dialling into the United Kingdom Telex Network over Long-Distance Radio Circuits ... ..  | 162         |
| Cable Systems, Automatic Switching of Inland Carrier-Link Sections of Transatlantic Telephone ... ..   | 237           | ENDERSBY, J. C., and BUFFIN, J. D. Temperature Tests for Transmission Equipment Located in Footway Joint-Boxes ... ..                                     | 160         |
| Cables in Subscribers' Local-Line Networks, Field Trials of Large Polythene ... ..   | 8             | Exchange-Line Costing Study ... ..  | 186         |
| Cables, Pressurization of Telecommunication (Parts 2, 3 and 4) ... ..  | 25, 129,      | Exhibitions at 2–12 Gresham Street, London, E.C.2, Inland Radio Planning and Provision Branch ... ..  | 244         |
| Calculator, A Simple Sum-of-Squares Electronic ... ..  | 6             | Experimental 3-Digit Electronic Director Using Magnetic-Core Circuits, An ... ..  | 255         |
|  |               | Extraordinary Administrative Radio Conference, Geneva, 7 October–8 November, 1963, The ... ..   | 251         |

|  | PAGE<br>NO.   |  | PAGE<br>NO.       |
|--|---------------|--|-------------------|
| <b>F</b>   |               | <b>K</b>   |                   |
| Field Trials of Large Polythene Cables in Subscribers' Local-Line Networks ... ..  | 8             | KEEP, J. F., CRAGGS, J. F., and WALTERS, J. R. Pressurization of Telecommunication Cables (Parts 2 and 3) ... ..                 | 25, 129           |
| FLETCHER, N. E., and HARRIS, R. H. Field Trials of Large Polythene Cables in Subscribers' Local-Line Networks ... ..   | 8             | Key-and-Lamp Desk Unit, New ... ..   | 156               |
| 405-Line Television Networks, Testing Facilities and Methods for ... ..  | 275           | Kilvington, T. (Appointment as Staff Engineer) ... ..  | 57                |
| FRENCH, J. A. T., HARDING, D. J., and JARVIS, J. R. Outline of Transistor Characteristics and Applications (Parts 1, 2 and 3) ... ..                           | 122, 196, 268 | <b>L</b>   |                   |
| Frequency-Generating Equipment for the Transoceanic Line-Signalling System ... ..  | 119           | Law, H. B. (Appointment as Staff Engineer) ... ..  | 57                |
| <b>G</b>   |               | Leigh, H. (Appointment as Deputy Director, E.T.E.) ... ..  | 204               |
| GARDINER, R. Testing Facilities and Methods for the 405-Line Television Networks ... ..  | 275           | LEVETT, A., DAGLISH, H. N., and CHILD, M. R. The Helium System of the Maser Installation at Goonhilly Radio Station ... ..       | 29                |
| GEE, J. H. An Improved Congestion Announcer ... ..   | 36            | LIGHT, R. A. M., and BROOKS, H. P. Pressurization of Telecommunication Cables (Part 4) ... ..                                    | 170               |
| GEE, J. H. Frequency-Generating Equipment for the Transoceanic Line-Signalling System ... ..   | 119           | Line and Register Signalling Systems for Dialling over Transoceanic Telephone Cables ... ..                                      | 111               |
| GOLDSMITH, J. R., and HEWSTONE, H. D. Exchange-Line Costing Study ... ..   | 186           | LOUGHHEAD, W. A. E., and MATTHEWS, G. A. An Experimental 3-Digit Electronic Director Using Magnetic-Core Circuits ... ..         | 255               |
| Goonhilly Radio Station, The Helium System of the Maser Installation at ... ..   | 29            | <b>M</b>   |                   |
| <b>H</b>   |               | Maddison, W. H. (Appointment as Staff Engineer) ... ..   | 206               |
| HALSEY, R. J. The Anglo-Canadian Transatlantic Telephone Cable System (CANTAT) ... ..  | 73            | Magnetic-Core Circuits, An Experimental 3-Digit Electronic Director Using ... ..   | 255               |
| Harbour Crossings, Pipe-Laying in Tidal Rivers and   | 166           | Magnetic Cores in Logical and Memory Circuits, The Use of ... ..   | 46                |
| HARDING, D. J., JARVIS, J. R., and FRENCH, J. A. T. Outline of Transistor Characteristics and Applications (Parts 1, 2 and 3) ... ..                           | 122, 196, 268 | Magnetic Drum, An Electronic Telegraph Buffer Store Using a ... ..   | 262               |
| HARRIS, R. H., and FLETCHER, N. E. Field Trials of Large Polythene Cables in Subscribers' Local-Line Networks ... ..   | 8             | Manhole and Joint-Box Frames and Covers Using Polyester Resin, Raising and Setting ... ..  | 252               |
| HEARN, A. F. L. Raising and Setting Manhole and Joint-Box Frames and Covers Using Polyester Resin Heating, Electric Underfloor ... ..                          | 252           | Manufacture of Earthenware Ducts, The ... ..   | 231               |
| Helium System of the Maser Installation at Goonhilly Radio Station, The ... ..   | 29            | MARKS, D. J. A Decade of Growth in the Trunk Telephone Network, 1952-62 ... ..   | 177               |
| HENDERSON, J. C., and WILSON, Sylvia J. Design and Technology of Silicon Planar Transistors ... ..   | 239           | Maser Installation at Goonhilly Radio Station, The Helium System of the ... ..   | 29                |
| HEPTINSTALL, D. L., and JONES, P. F. Switching Arrangements for Semi-Automatic Operation of Transoceanic Telephone Cable Circuits ... ..                       | 105           | MATTHEWS, G. A., and LOUGHHEAD, W. A. E. An Experimental 3-Digit Electronic Director Using Magnetic-Core Circuits ... ..         | 255               |
| HEWSTONE, H. D., and GOLDSMITH, J. R. Exchange-Line Costing Study ... ..   | 186           | Merriman, J. H. H. (Appointment as Assistant Engineer-in-Chief) ... ..   | 56                |
| HILLEN, C. F. J., and BANHAM, H. The Use of Magnetic Cores in Logical and Memory Circuits ... ..   | 46            | MERRIMAN, J. H. H. The Place of V.H.F., U.H.F. and S.H.F. Radio Links in a Developing Area ... ..                                | 149               |
| House Exchange System—House Exchange System No. 3, A Simplified ... ..   | 15            | MILES, J. V. Introduction of International Subscriber Dialling from the London Director Area to Paris ... ..                     | 33                |
| Housing of Repeater Equipment Underground ... ..   | 158           | Moffat, C. E. (Retirement) ... ..  | 207               |
| HUNTER, R. S. Ventilation Plant for the Post Office Engineering Department's Main Conference Room ... ..   | 194           | Mumford, Sir Albert (Award of K.B.E.) ... ..   | 136               |
| <b>I</b>   |               | MUMFORD, Sir Albert. Communications in the Public Service of the United Kingdom ... ..   | 223               |
| Improved Congestion Announcer, An ... ..   | 36            | <b>N</b>   |                   |
| Inland Radio Planning and Provision Branch Exhibitions at 2-12 Gresham Street, London, E.C.2 ... ..  | 244           | New Key-and-Lamp Desk Unit ... ..  | 156               |
| Institution of Post Office Electrical Engineers 59, 136, 212, International Subscriber Dialling from the London Director Area to Paris, Introduction of ... .. | 33            | New Post Office Speaking Clocks, The ... ..  | 1                 |
| Introduction of International Subscriber Dialling from the London Director Area to Paris ... ..  | 33            | New Watch Receiver—Receiver, Watch, No.8T, A ... ..  | 230               |
| <b>J</b>   |               | Nichols, C. A. L. (Appointment as Chief Regional Engineer) ... ..  | 208               |
| JACKSON, F. G. Subscriber Trunk Dialling for U.A.X. Subscribers ... ..   | 21            | New Training Scheme for Post Office Engineering Youths ... ..  | 184               |
| JARVIS, J. R., FRENCH, J. A. T., and HARDING, D. J. Outline of Transistor Characteristics and Applications (Parts 1, 2 and 3) ... ..                           | 122, 196, 268 | Notes and Comments ... ..  | 55, 136, 204, 283 |
| Joint-Box Frames and Covers Using Polyester Resin, Raising and Setting Manhole and ... ..  | 252           | <b>O</b>   |                   |
| JONES, F., BROCKBANK, R. A., and CLARKE, E. F. S. Anglo-Canadian Transatlantic Telephone Cable (CANTAT): Cable Development, Design and Manufacture ... ..      | 82            | Outline of Transistor Characteristics and Applications, Part 1—Transistor Parameters and Stabilization of Characteristics ... .. | 122               |
| JONES, P. F., and HEPTINSTALL, D. L. Switching Arrangements for Semi-Automatic Operation of Transoceanic Telephone Cable Circuits ... ..                       | 105           | Part 2—Application of Linear Characteristics ... ..  | 196               |
|  |               | Part 3—Application of Non-Linear Characteristics ... ..  | 268               |
|  |               | <b>P</b>   |                   |
|  |               | Pipe-Laying in Tidal Rivers and Harbour Crossings ... ..   | 166               |
|  |               | Place of V.H.F., U.H.F. and S.H.F. Radio Links in a Developing Area, The ... ..  | 149               |
|  |               | Plastics, The Testing of ... ..  | 280               |
|  |               | Polythene Cables in Subscribers' Local-Line Networks, Field Trials of Large ... ..   | 8                 |
|  |               | Polythene-Sheathed Paper-Core Unit Twin Cable (S) ... ..   | 32                |
|  |               | Post Office Engineering Department's Computer—Its Use in Research, The ... ..  | 133               |
|  |               | Power Plants, Saving Space in Telephone Exchanges by Using Modern ... ..   | 23                |
|  |               | Preservation of Cable Drums ... ..   | 44                |

|  | PAGE<br>NO.       |  | PAGE<br>NO.   |
|--|-------------------|--|---------------|
| Pressurization of Telecommunication Cables,<br>Part 2—The Supply of Dry Compressed Air ...   | 25                | Testing Facilities and Methods for the 405-Line Tele-<br>vision Network ...  | 275           |
| Part 3—Miscellaneous Pressurization Equipment ...  | 129               | Testing of Plastics, The ...   | 280           |
| Part 4—The Operation of Gas-Pressure Systems<br>and Fault-Locating Techniques ...  | 170               | THOMAS, J. F. P., WALKER, D. C., SCOWEN, F., and<br>TAYLOR, S. A. Anglo-Canadian Transatlantic Tele-<br>phone Cable (CANTAT): Submerged Repeaters,<br>Equalizers and Associated Terminal Equipment ... | 76            |
| Pressurization of the Trunk Cable Network, Effect on<br>Service During 1962-63 of the ...  | 176               | THOMSON, W. E. The Post Office Engineering Depart-<br>ment's Computer—Its Use in Research ...  | 133           |
| PRIESTLEY, W. D. Pipe-Laying in Tidal Rivers and Har-<br>bour Crossings ...  | 166               | Thrust-Borer, A Small Hand-Operated Hydraulic ...  | 192           |
| <b>R</b>   |                   |  |               |
| Raising and Setting Manhole and Joint-Box Frames and<br>Covers Using Polyester Resin ...   | 252               | Tolley, L. L. (Retirement) ...   | 204           |
| RANDALL, F. L., and WARD, S. A. L. A Simplified House<br>Exchange System—House Exchange System No. 3 ...   | 15                | Training Schemes for Post Office Engineering Youths,<br>New ...  | 184           |
| Receiver, Watch, No.8T, A New Watch Receiver— ...  | 230               | Transatlantic Telephone Cable (CANTAT): Cable<br>Development, Design and Manufacture, Anglo-<br>Canadian ...   | 82            |
| REES, T. J. New Training Scheme for Post Office<br>Engineering Youths ...  | 184               | Transatlantic Telephone Cable (CANTAT): Cable-<br>Laying Gear, Anglo-Canadian ...  | 91            |
| Regional Notes ...   | 60, 138, 214, 286 | Transatlantic Telephone Cable (CANTAT): Laying the<br>North Atlantic Link, Anglo-Canadian ...  | 99            |
| Register Signalling Systems for Dialling Over Trans-<br>oceanic Telephone Cables, Line and ...   | 111               | Transatlantic Telephone Cable (CANTAT): Submerged<br>Repeaters, Equalizers and Associated Terminal<br>Equipment, Anglo-Canadian ...  | 76            |
| Repeater Equipment Underground, Housing of ...   | 158               | Transatlantic Telephone Cable System (CANTAT),<br>The Anglo-Canadian ...   | 73            |
| Rivers and Harbour Crossings, Pipe-Laying in ...   | 166               | Transatlantic Telephone Cable Systems, Automatic<br>Switching of Inland Carrier-Link Sections of ...   | 237           |
| ROBINS, J. M., and CROISDALE, A. C. An Electronic Tele-<br>graph Buffer Store Using a Magnetic Drum ...  | 262               | Transistor Characteristics and Applications, Outline<br>of (Parts 1, 2 and 3) ...  | 122, 196, 268 |
| ROBINSON, J. Saving Space in Telephone Exchanges by<br>Using Modern Power Plants ...   | 23                | Transistors, Design and Technology of Silicon Planar ...   | 239           |
| <b>S</b>   |                   |  |               |
| S.H.F. Radio Links in a Developing Area, The Place of<br>V.H.F., U.H.F. and ...  | 149               | Transistor-Type 4-Wire Audio Equipment ...   | 40            |
| Saving Space in Telephone Exchanges by Using Modern<br>Power Plants ...  | 23                | Transmission Equipment Located in Footway Joint-<br>Boxes, Temperature Tests for ...   | 160           |
| SCOWEN, F., TAYLOR, S. A., THOMAS, J. F. P., and<br>WALKER, D. C. Anglo-Canadian Transatlantic Tele-<br>phone Cable (CANTAT): Submerged Repeaters,<br>Equalizers and Associated Terminal Equipment ... | 76                | Transoceanic Line-Signalling System, Frequency Gen-<br>erating Equipment for the ...   | 119           |
| Semi-Automatic Operation of Transoceanic Telephone-<br>Cable Circuits, Switching Arrangements for ...  | 105               | Transoceanic Telephone Cable Circuits, Switching<br>Arrangements for Semi-Automatic Operation of ...   | 105           |
| 700-Type Telephone, Standardization and Control of<br>Colour for the ...   | 247               | Transoceanic Telephone Cables, Line and Register<br>Signalling Systems for Dialling Over ...   | 111           |
| Signalling System, Frequency-Generating Equipment for<br>the Transoceanic Line ...   | 119               | TROME, F. E. A New Watch Receiver—Receiver, Watch,<br>No.8T. ...   | 230           |
| Signalling Systems for Dialling Over Transoceanic Tele-<br>phone Cables, Line and Register ...   | 111               | Trunk Telephone Network, 1952-62, A Decade of Growth<br>in the ...   | 177           |
| Simple Sum-of-Squares Electronic Calculator, A ...   | 6                 | <b>U</b>   |               |
| Simplified House Exchange System—House Exchange<br>System No. 3, A ...   | 15                | U.A.X. Subscribers, Subscriber Trunk Dialling for ...  | 21            |
| Small Hand-Operated Hydraulic Thrust-Borer, A ...  | 192               | U.H.F. and S.H.F. Radio Links in a Developing Area,<br>The Place of V.H.F., ...  | 149           |
| Sorting Offices, Tape-Recording Machine for Ticking-<br>in Mails at ...  | 118               | Use of Magnetic Cores in Logical and Memory Circuits,<br>The ...   | 46            |
| Speaking Clocks, The New Post Office ...   | 1                 | <b>V</b>   |               |
| Staff Changes ...  | 66, 145, 219, 291 | V.H.F., U.H.F. and S.H.F. Radio Links in a Developing<br>Area, The Place of ...  | 149           |
| Standardization and Control of Colour for the 700-Type<br>Telephone ...  | 247               | Ventilation Plant for the Post Office Engineering Depart-<br>ment's Main Conference Room ...   | 194           |
| Stratton, J. (Retirement) ...  | 208               | <b>W</b>   |               |
| STENSON, D. W., and CLINCH, C. E. E. Housing of Re-<br>peater Equipment Underground ...  | 158               | WALKER, D. C., SCOWEN, F., TAYLOR, S. A., and THOMAS,<br>J. F. P. Anglo-Canadian Transatlantic Telephone<br>Cable (CANTAT): Submerged Repeaters, Equalizers<br>and Associated Terminal Equipment ...   | 76            |
| STENSON, D. W. The Manufacture of Earthenware Ducts<br>Subscriber Trunk Dialling for U.A.X. Subscribers ...  | 231               | WALKER, R. R. The New Post Office Speaking Clocks ...  | 1             |
| Switching Arrangements for Semi-Automatic Operation<br>of Transoceanic Telephone-Cable Circuits ...  | 105               | WALTERS, J. R., KEEP, J. F., and CRAGGS, J. F. Pressur-<br>ization of Telecommunication Cables (Parts 2<br>and 3) ...  | 25, 129       |
| <b>T</b>   |                   |  |               |
| Tape-Recording Machine for Ticking-in Mails at Sorting<br>Offices ...  | 118               | WARD, S. A. L., and RANDALL, F. L. A Simplified House<br>Exchange System—House Exchange System No. 3 ...   | 15            |
| TAYLOR, P. E. The Testing of Plastics ...  | 280               | WATKINS, A. H. "Better Opportunities in Technical Edu-<br>cation" ...  | 13            |
| TAYLOR, S. A., THOMAS, J. F. P., WALKER, D. C., and<br>SCOWEN, F. Anglo-Canadian Transatlantic Tele-<br>phone Cable (CANTAT): Submerged Repeaters,<br>Equalizers and Associated Terminal Equipment ... | 76                | Watt-Carter, D. E. (Appointment as Staff Engineer) ...   | 209           |
| Telephone, Standardization and Control of Colour for<br>the 700-Type ...   | 247               | Webber, F. W. J. (Appointment as Staff Engineer) ...   | 283           |
| Television Networks, Testing Facilities and Methods<br>for the 405-Line ...  | 275               | WELCH, S. Line and Register Signalling Systems for<br>Dialling Over Transoceanic Telephone Cables ...  | 111           |
| Telex Network over Long-Distance Radio Circuits,<br>Dialling into the United Kingdom ...   | 162               | WILLIAMS, J. Electric Underfloor Heating ...   | 181           |
| Temperature Tests for Transmission Equipment Located<br>in Footway Joint-Boxes ...   | 160               | WILSON, Sylvia J., and HENDERSON, J. C. Design and<br>Technology of Silicon Planar Transistors ...   | 239           |
|  |                   | WOODING, R. S. G. Automatic Switching of Inland<br>Carrier-Link Sections of Transatlantic Telephone<br>Cable Systems ...   | 237           |

## ASSOCIATE SECTION NOTES (Continued from p. 290)

In view of the interesting and varied nature of the talks and visits, we see no reason why this session should not prove as popular, or even more so, than the previous one.

A.H.McW.

### London Centre

Entitled "Experimental Communications via Earth Satellites," the opening lecture of the 1963-64 session was given by Mr. V. C. Meller, Space Communication Systems Branch, Engineering Department, to a large audience in the Assembly Hall at Fleet Building. Mr. Meller explained the part played by the Post Office in collaboration with the American engineers, and outlined the development of the first working satellite system, emphasizing that it was—despite the blaze of publicity it received—only experimental. He dealt in some detail with the construction of the dish aerial at the satellite ground station, Goonhilly Downs, illustrating his remarks with slides, a film, and a scale working model of the aerial. This was followed by a brief description of the transmitting and receiving equipment at Goonhilly Downs, and an American film of the first live transmission across the Atlantic by the Post Office in July 1962, via TELSTAR. He concluded his talk with a look into the future of satellite communications and an appraisal of the various systems and orbital tracks that might be used.

September also saw the formation of a new area within the London Centre. Previously the radio stations at Brentwood and Ongar were part of Cable and Wireless, Ltd., but as their geographical remoteness made participation in the various activities rather difficult, one of their number decided to break away and form a local committee—an action which has been approved and ratified by the central committee.

The October lecture, given by Mr. R. P. Boardman, Ericsson Telephones, Ltd., was a repeat of the one given previously before the Institution. The subject was "Bank Contact Wear," in which the speaker discussed the problem of dust and dirt in telephone exchanges, using as illustrations slides of actual dust samples collected. He

then made a comparison with the effects found in other countries, particularly in the Middle East, where the abrasive action of sand on electrical rubbing contacts is well known for its severity. He said that dust-proofed equipment installed at various exchanges was giving satisfactory results, but pointed out that the most effective remedy was the use of dry contact lubrication. To this end, the flush nylon bank has been developed for two-motion selectors, with remarkable evidence of greatly-increased life of contacts, even when heavily electrically loaded. Mr. Boardman's talk was extensively illustrated with slides and slow-motion films, showing various aspects of a most interesting subject.

In October, one of the stalwarts (in more senses than one) of the central committee resigned his post of Librarian and Technical Quiz Organizer. The bearded and amply proportioned figure of Geoffrey Milne, his prodigious reports, and his competent administration of the Quiz are to be remembered. It is our sincere hope that he will have every success in his new job at the Central Training School, Stone, where he is to be an instructor.

A number of links have been forged in recent months with the aim of giving the Associate Section more publicity. It is planned to produce a brochure explaining our purpose and various activities, with the added hope that it might be possible to distribute it on a national basis. Local publicity is envisaged by means of "induction courses" for new entrants to the service, whereby area chairmen would make it their responsibility to address newly-recruited Youths-in-Training as a group, to obviate some of the ignorance and bewilderment that generally exists.

The November talk was given by Mr. S. Rata, External Plant and Protection Branch, Engineering Department, who spoke on the "Harmstorf Flush Jet Bedding System for Cables." He discussed the three main ways of flush jet bedding for laying cables, and then, with the aid of film and slides, described the demonstration seen by him on the Continent by the Rudolf Harmstorf Company of Hamburg, of this ingenious method of laying cables under rivers, estuaries and swamps. E.S.G.

### BOARD OF EDITORS

D. A. BARRON, C.B.E., M.Sc., M.I.E.E., Chairman.  
L. F. SCANTLEBURY, Whit.Sch., A.C.G.I., D.I.C., M.I.E.E.  
T. H. FLOWERS, M.B.E., B.Sc.(Eng.), M.I.E.E.  
W. J. E. TOBIN, B.Sc.(Eng.), A.C.G.I., D.I.C., M.I.E.E.  
E. J. MARKBY, A.M.I.E.E.  
D. J. HARRIS, B.Sc.(Eng.), A.M.I.E.E.  
R. F. WALDEGRAVE.  
A. G. LEIGHTON, B.Sc.(Eng.), A.M.I.E.E., Managing Editor.  
J. MARTIN, B.Sc.(Eng.), A.M.I.E.E., Deputy Managing Editor.  
J. A. POVEY, A.M.I.E.E. } Assistant Editors.  
R. A. SUDELL. }  
B. FARR, A.B.I., Secretary-Treasurer.  
B. CROSS, Advertisement Manager.

### Copyright

The entire contents of this Journal are covered by general copyright, and special permission is necessary for reprinting long extracts, but editors are welcome to use not more than one-third of any article, provided that credit is given at the beginning or end thus: "From *The Post Office Electrical Engineers' Journal*."

The Board of Editors is not responsible for the statements made or the opinions expressed in any of the articles in this Journal, unless such statement is made specifically by the Board.

### Subscriptions and Back Numbers

The Journal is published quarterly, in April, July, October and January, at 3s. per copy; the post-paid price is 4s. per copy (16s. per year) via inland mail, and 4s. 3d. (17s., or 2 dollars 75 cents Canada and U.S.A., per year) via overseas mail. Back numbers will be supplied, if available, price 3s. (4s. inland mail, 4s. 3d. overseas mail) per copy. With the exception of April and

July 1961 Journals, copies of the January 1963 and all earlier Journals are no longer available. Orders should be sent to *The Post Office Electrical Engineers' Journal*, G.P.O., 2-12 Gresham Street, London, E.C.2.

Employees of the British Post Office can obtain the Journal through local agents.

### Binding

Readers can have their copies of volumes bound at a cost of 15s. by sending the complete set of parts to the local Post Office distribution agent or to *The Post Office Electrical Engineers' Journal*, G.P.O., 2-12 Gresham Street, London, E.C.2.

### Remittances

Remittances should be made payable to "*The P.O.E.E. Journal*" and should be crossed "& Co."

### Advertisements

All correspondence relating to advertisement space reservations, copy, proofs, etc., should be addressed to the Advertisement Manager, *The Post Office Electrical Engineers' Journal*, G.P.O., 2-12 Gresham Street, London, E.C.2.

### Communications

With the exceptions indicated above, all communications should be addressed to the Managing Editor, *The Post Office Electrical Engineers' Journal*, G.P.O., 2-12 Gresham Street, London, E.C.2. Telephone: HEAdquarters 1234.

### Model Answer Books

Books of model answers to certain of the City and Guilds of London Institute examinations in telecommunications are published by the Board of Editors. Details of the books available are given at the end of the Supplement to the Journal.



# TMC supply a Nationwide Telegraph Network in VENEZUELA

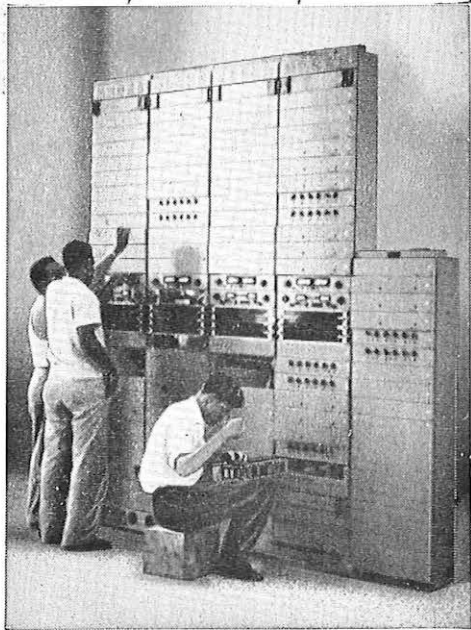

TMC transistorised FM  
VF telegraph equipment, type T24D,  
installed in twelve major centres

TMC engineers have just completed this important installation of T24D terminals at the twelve centres indicated. The inset shows TMC and Venezuelan engineers at work on the installation at Puerto la Cruz. This contract is an example of the type of system and installation which many administrations are trusting TMC to undertake.

Their trust is not misplaced. TMC has many years of expert experience in the field of telecommunications.



**TELEPHONE MANUFACTURING COMPANY LIMITED**  
Dept. X, Transmission Division  
Sevenoaks Way · St. Mary Cray · Orpington · Kent · Telephone: Orpington 27020

A MEMBER OF THE  GROUP OF COMPANIES

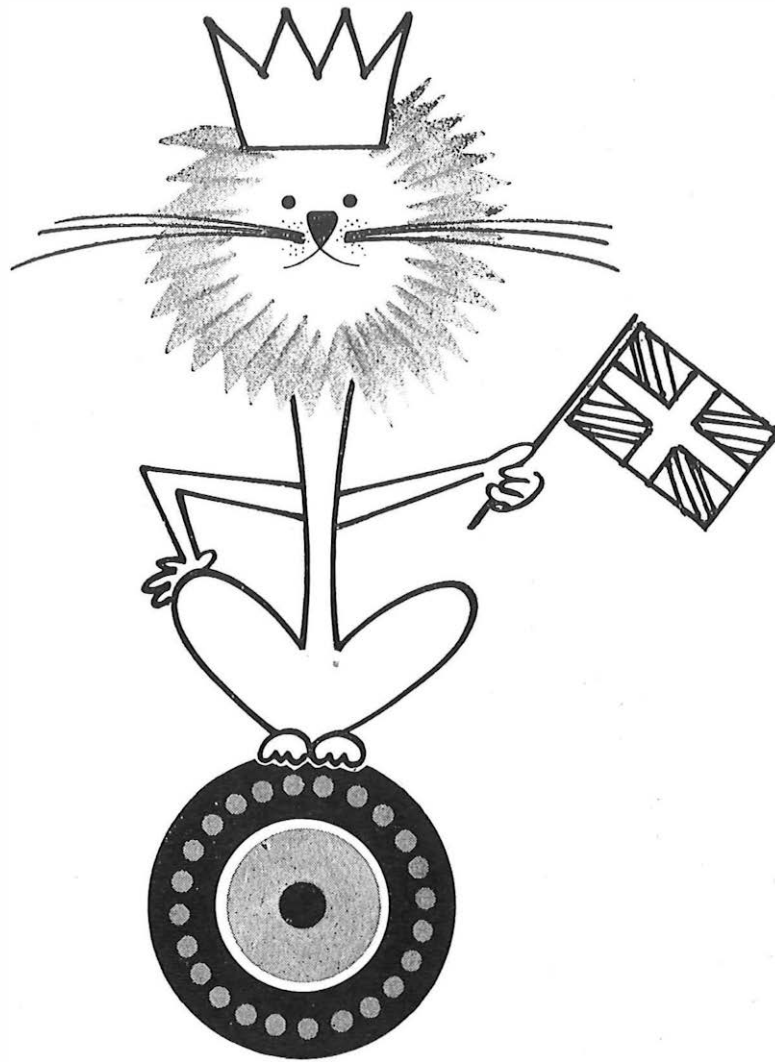

# THE LION'S SHARE

Submarine Cables Ltd., England, and its predecessors have pioneered and supplied far the largest proportion of the world's submarine telecommunication cable—90% of the telegraph cable between 1850 and 1950 and the largest share of telephone cable since 1950—also the main cable-laying gear for Cable Ships, MONARCH, ALERT, MARCEL BAYARD, MERCURY, INGUL and JANA. For submarine telecommunication cable, repeaters and—through AEI—terminal equipment; for cable handling gear and also for deck auxiliaries, consult:

HERE ARE SOME OF THE COMPANY'S MILESTONES:

- 1850** *First ever submarine telegraph cable—  
from England to France.*
- 1866** *First successful transatlantic telegraph cable.*
- 1939** *First polythene-insulated submarine cable.*
- 1955/6** *First transatlantic telephone cable—  
95% supplied by the Company.*
- 1961** *First armourless telephone cable—  
2000 miles from Newfoundland to England.*
- 1961** *Longest repeatered 120-circuit telephone cable—  
400 miles from Newfoundland to Canada.*
- 1961/3** *Supply over 5000 miles of armourless  
cable and 90 repeaters for the 8000-mile  
Commonwealth Pacific system.*
- 1962** *Contract for 420-circuit transistorised repeaters*

## SUBMARINE CABLES LIMITED

(OWNED JOINTLY BY AEI AND BICC) • MERCURY HOUSE • THEOBALD'S RD • LONDON WC1 • ENGLAND



# manufactures telephones for all applications



**S.E.C. 706 telephone**  
a general purpose table instrument.

**S.E.C.** also produces intercommunication sets, loudspeaking telephones and telephones for special applications for ships, railways, mines etc.



**S.E.C. 711 telephone**  
a general purpose wall instrument.



**S.E.C. 710 telephone**  
for plan and extension systems and special facilities.



**S.E.C. switching telephone**  
for plan 105 and plan 107 operation.

Telephone Division

**S.E.C. (TELECOMMUNICATIONS) LTD · TELEPHONE WORKS · COVENTRY · ENGLAND**

Works at Coventry and Middlesbrough



# \* "Celcurised"

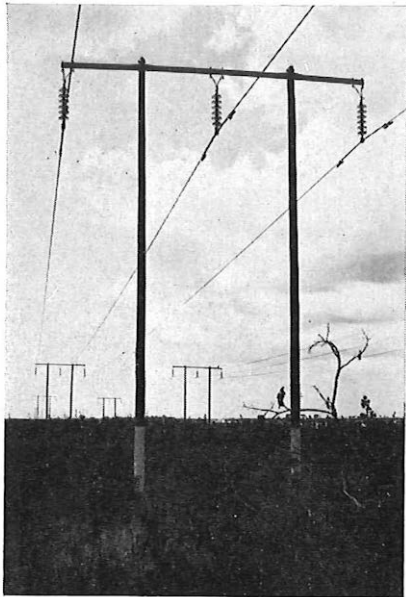

## POLES,

East Africa Power & Lighting Co. of Nairobi have been treating all poles and cross arms for their transmission lines with Celcure for over 10 years. The illustration shows the 66 kV ring main around Nairobi carried on Pilkington glass discs mounted on "Celcurised" cross arms and double poles.

\* "Celcurised" timber which has been correctly vacuum/pressure impregnated with Celcure wood preservative to afford lasting protection against fungal decay and insect attack and/or termites.

## DRUMS

The failure of a loaded cable drum wherever it may be is a highly expensive and troublesome problem. In fact, if the site of the failure is sufficiently remote, it can mean the complete loss of valuable cable and perhaps necessitate replacement from the other side of the world. Even the continual replacement of returnable drums, through decay, is a costly practice.

At General Woodworkers Ltd., Penn, Buckinghamshire, virtually all their drums are Celcure treated. The photograph illustrates a 10 ft. diameter drum with the vacuum/pressure impregnation plant in the background and smaller drum flanges being wheeled to the pressure cylinder for loading. Appropriate treatment with Celcure affords lasting protection against decay and termite attack. The G.P.O. now specify vacuum/pressure impregnation for all their drums.



## and more POLES

Australian hardwood poles emerging from the pressure cylinder after impregnation with Celcure 'A' wood preservative. \* "Celcurised" transmission poles are being increasingly employed in Australia and it was with this in view that Brandon Timbers Ltd., established a Celcure plant at their pole yard in Queensland. The treatment cylinder which is seen in the photograph is 85' long x 6' diameter.

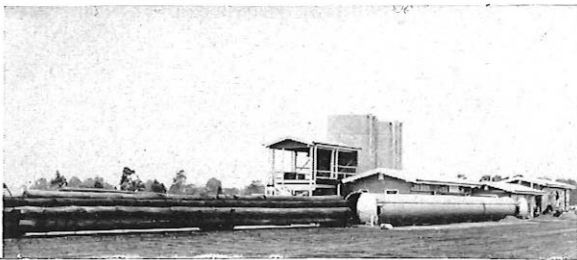

*Extracts from The "Celcure" Bulletin*



For free details of "Celcurised" timber for particular purposes and regular receipt of The Celcure Bulletin, please complete and return the coupon today.

Name .....

Company .....

Address .....

For England, Wales and Overseas: Celcure Ltd., Kingsway House, Kingsway, London, W.C.2  
Tel.: CHAncery 8325

For Scotland and Northern Ireland: Celcure & Chemical Co. Ltd., 300 Bearsden Road, Glasgow, W.3  
Tel.: JORDAnhill 8021

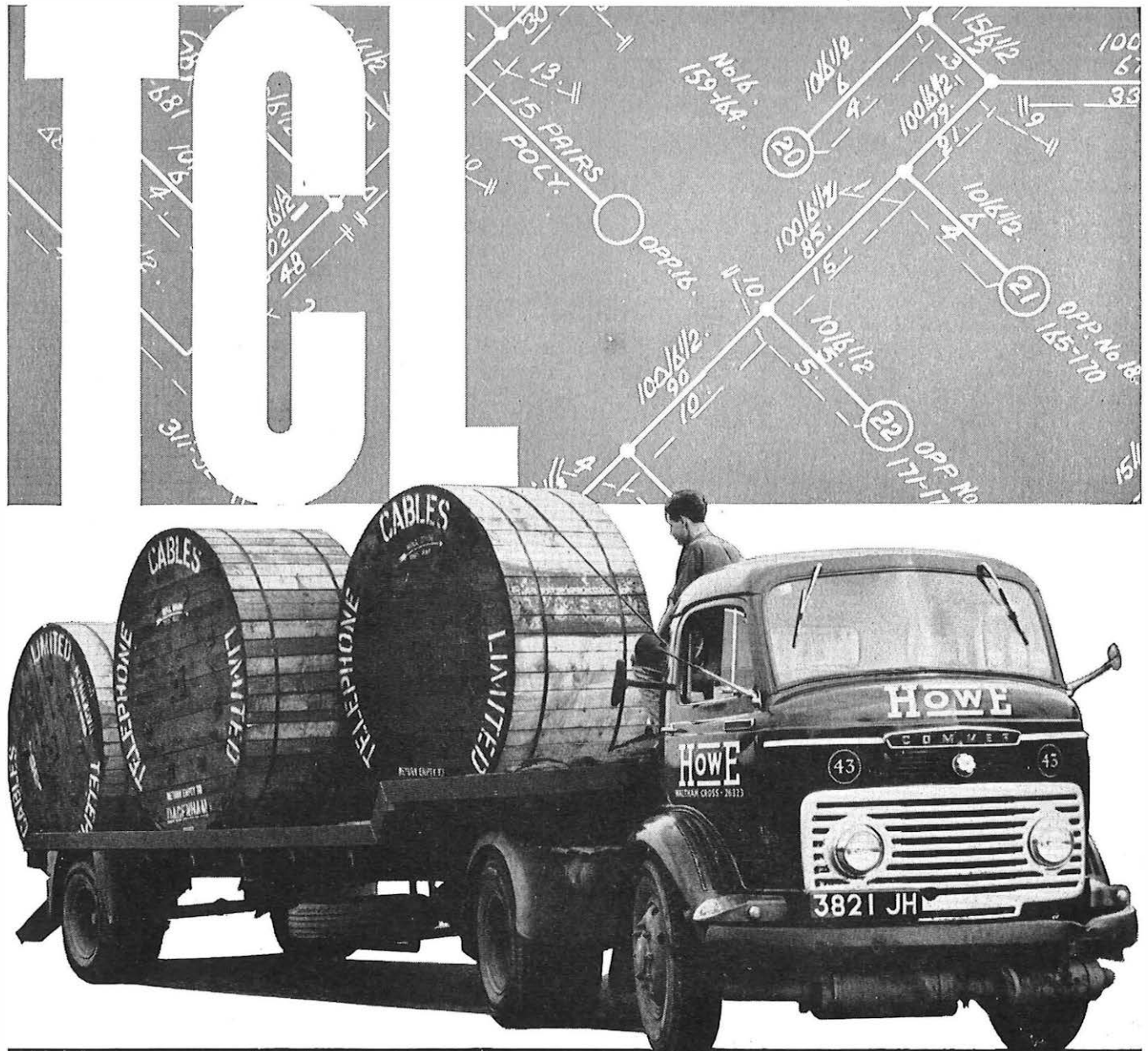

## Exchange Network design, planning and installation—call in the specialists!

The investigation and planning of a new network or an extension to an existing network is a job for the specialist. TCL's immense resources and unique experience in this field, not only of cable engineering practice, but of the many economic factors involved, means that complete schemes can be installed with speed and efficiency—at minimum cost.

TCL undertake initial surveys, check routes, produce up-to-date plant records, forecast potential requirements, design, manufacture and install the cables and plant for complete telecommunication networks.

TCL and their associates AEI Telecommunications Division, are able to offer a comprehensive service for the supply of cable and equipment for any type of telephone network. For projects planned to the smallest detail, projects designed for long-term service and reliability anywhere in the world, call in the specialists—**TCL**.

### **TELEPHONE CABLES LIMITED**

Dagenham, England Tel: Dominion 6611 Cables: Drycore Dagenham

THE ORGANISATION WITH 125 YEARS' EXPERIENCE

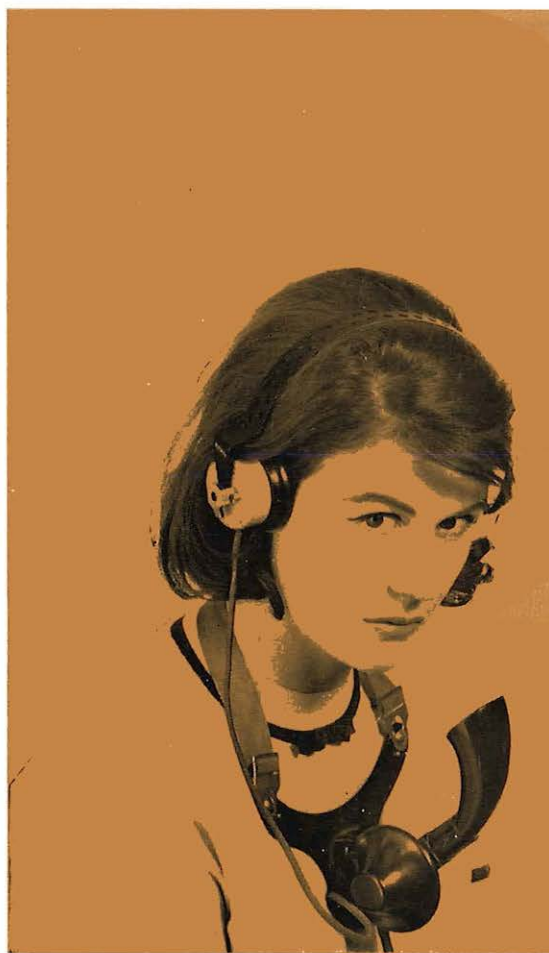

**STC MAKES LIGHT OF THE JOB** with their lightweight headsets, designed for use by private and public telephone operators and approved by the British Post Office. These are fast superseding the use of the older breast-type instruments. Main advantages are: Extraordinary light weight, high degree of comfort, stability and manoeuvrability and constant level of transmission regardless of head movement. The headsets are made in black, grey or ivory nylon plastic which is virtually unbreakable. The "Rocking Armature" principle — an important STC development in telephone receiver design — which gives improved sensitivity and frequency response has been incorporated into these instruments. Write, 'phone or Telex for leaflet D/104 to Standard Telephones and Cables Limited, Telephone Switching Division, Oakleigh Road, New Southgate, London, N.11. Telephone ENTerprise 1234. Telex 21612.

world-wide telecommunications and electronics

**STC**

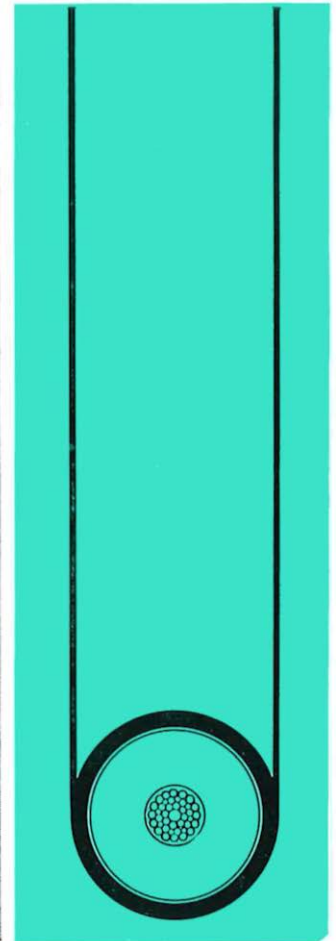

**STC AND WORLD'S LONGEST SUBMARINE CABLE...** STC has a £5 million contract for cable to be manufactured in their Southampton factories. Most of this American designed, lightweight cable will be for TAT-3, the first direct telephone cable link between the USA and Britain. TAT-3 will provide 128 transatlantic voice circuits; a substantial increase over earlier transatlantic cables. During 1963, the cable ship HMTS Alert, illustrated, and the American cable ship Long Lines are making visits to load cable at the STC factories. STC and its international associates of the vast ITT group are uniquely equipped to further communications on a transoceanic scale. Standard Telephones and Cables Limited, Submarine Cables Division, New Docks, Southampton, Hants.

world-wide telecommunications and electronics **STC**

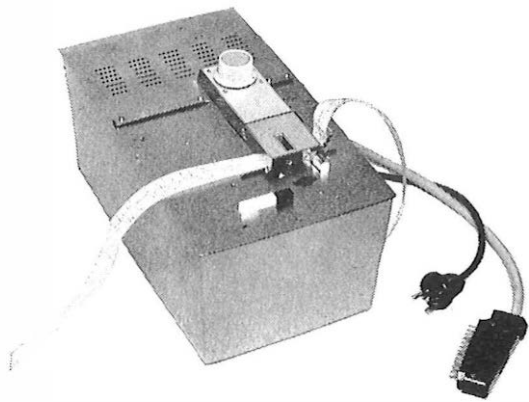

G.N.T. Tape and Edge Card Reader, Model 23

# G.N.T.

## INSTRUMENTS

- Complete range of Wheatstone equipment
- Complete range of special Morse training equipment
- G.N.T. 5-unit Transmitters with one or two sensing heads
- G.N.T. Converters for Morse or Cable Code to 5-Unit or 5-Unit to Morse or Cable Code
- G.N.T. Tape Readers for 5, 6, 7 or 8 Unit Tape

# GREAT NORTHERN TELEGRAPH WORKS

4 SYDHAVN PLADS  
COPENHAGEN DENMARK

LONDON OFFICE:  
5 ST HELENS PLACE EC3

# OXLEY

## BARB INSULATORS

### TYPE 062

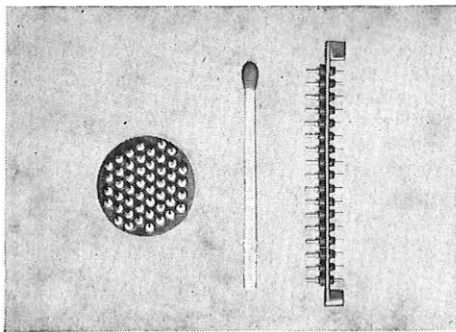

Working voltage 500 V DC  
Capacity less than 5 pF  
Temperature range -55°C to +200°C  
Resistance to pull in either direction 3 lbs.  
Chassis thickness 22/24 SWG, 0.027" 0.28", 0.56/0.72 mm.  
Mounting hole dia. 0.02", 1/16", 1.58 mm.

A new subminiature insulator, which is speedy to assemble, and with outstanding physical characteristics. The P.T.F.E. bush, which is supplied with the heavily silver plated brass 'barb' partly inserted, is located in an ordinary .062" dia. hole and the barbed spill is pressed firmly through the assembly, thus expanding the P.T.F.E. bush on the far side of the chassis and locking the complete assembly firmly in the chassis.

Write for technical details of these and other Oxley products:

**OXLEY DEVELOPMENTS CO. LTD.**  
ULVERSTON LANCASHIRE

enlarged to three times the size of its predecessor and brought right up-to-date



## microphones

SECOND EDITION

A. E. Robertson, B.Sc.(Eng.), A.M.I.E.E.

This second edition of MICROPHONES is three times as large as its predecessor—chiefly on account of the whole new range of microphones that has resulted from the introduction of miniaturised pre-amplifiers, and the great improvements made in the directional properties of microphones. Primarily a training manual for BBC technicians, it will prove invaluable to all users of high-quality microphones.

**75s net** by post 76s 2d  
359 pp. plus 9 pages of plates

obtainable from  
leading booksellers

Published by

**ILIFFE Books Ltd**

DORSET HOUSE STAMFORD STREET LONDON S.E.1

# Model 8 Universal AVOMETER



## Designed for Dependability

The Model 8 Universal Avometer is a high sensitivity multi-range ac/dc electrical testing instrument providing 30 ranges of readings on a 5-inch hand calibrated scale. Range selection is effected by two rotary switches for a.c. and d.c. respectively.

The instrument has a sensitivity of 20,000 ohms per volt on d.c. voltage ranges and 1,000 ohms per volt on a.c. from the 100 volt range upwards, and meets the accuracy requirements of B.S.S. 89/1954 for 5-inch scale length portable industrial instruments. It is robust, compact and simple to operate, and is protected by an automatic cut-out against damage through inadvertent electrical overload.

| VOLTAGE  |          | CURRENT      |         | RESISTANCE   |
|----------|----------|--------------|---------|--|
| d.c.     | a.c.     | d.c.         | a.c.    |  |
| 2.5 V.   | 25 V.    | 50 $\mu$ A.  | 108 mA. | First indication 0.5 $\Omega$<br>Maximum indication 20 M $\Omega$<br>0—2,000 $\Omega$ } using<br>0—200,000 $\Omega$ } internal<br>0—20 M $\Omega$ } batteries<br>0—200 M $\Omega$ } using<br>} external<br>} batteries |
| 10 V.    | 10 V.    | 250 $\mu$ A. | 1 A.    |  |
| 25 V.    | 25 V.    | 1 mA.        | 2.5 A.  |  |
| 100 V.   | 100 V.   | 10 mA.       | 10 A.   |  |
| 250 V.   | 250 V.   | 100 mA.      | —       |  |
| 500 V.   | —        | 1 A.         | —       |  |
| 1,000 V. | 1,000 V. | 10 A.        | —       | <b>DECIBELS</b><br>— 15 dB to + 15 dB.   |
| 2,500 V. | 2,500 V. | —            | —       |  |



Various external accessories are available for extending the above ranges of measurement. Leather carrying cases are also available if required.

Dimensions: 8 1/4 x 7 1/4 x 4 1/2 inches. Weight: 6 1/2 lb.

Write for fully descriptive Folder or for complete Catalogue of AVO Instruments.

We can deliver the Model 8 Avometer promptly.

**AVO LTD** AVOCET HOUSE · 92-96 VAUXHALL BRIDGE ROAD · LONDON · S.W.1 Telephone: VIctoria 3464 (12 lines)

A8/6

# Pitman

## ELECTRICAL MEASUREMENTS AND MEASURING INSTRUMENTS

E. W. GOLDING, O.B.E., M.Sc.TECH., M.I.E.E. AND F. C. WIDDIS, PH.D., A.M.I.E.E.

This popular textbook covers the syllabuses of the B.Sc.(Eng.), I.E.E., and Dip.Tech. examinations in this subject. For this new edition the text has been extensively revised and rewritten in the M.K.S. system of units. Fifth Edition 50s net.

## MATRIX ALGEBRA FOR ELECTRICAL ENGINEERS

R. BRAAE, M.Sc.(ENG.), HONS.B.Sc., M.S.A.I.E.E.

Written by an electrical engineer for electrical engineers this book covers sufficient of the elements of matrix algebra to enable those with a modest mathematical background to understand articles and books in which the matrix notation is employed. 30s net

## PRINCIPLES OF HIGH-FIDELITY SOUND ENGINEERING

D. L. A. SMITH, B.Sc.(ENG.), A.M.I.E.E., A.M.BRIT.I.R.E.

In this new book the principles of high-fidelity sound reproduction are presented particularly for those with an engineering background such as senior technicians, junior design engineers and serious amateur enthusiasts. 25s net

from all booksellers · Pitman, Parker St., London, WC2

# VALUABLE FREE BOOK

Tells You How to Pass Your C. & G. Examination at First Attempt!

All Post Office personnel who are anxious to obtain early promotion should at once send for a copy of our handbook "ENGINEERING OPPORTUNITIES" which, among other intensely interesting matter, describes our unique methods of preparation for the CITY AND GUILDS EXAMINATIONS for the Telecommunication Technicians' Certificate and for individual subjects—Mathematics, Engineering Science, Engineering Drawing, Elementary Telecommunication Practice, Telecommunication Principles, Radio and Line Transmission, Telegraphy and Telephony, Line Plant Practice. It also contains details of our courses covering the C.C.E. subjects required for promotion to Assistant Engineer, Telecommunication Traffic Superintendent and other grades; and the City and Guilds examinations in Electrical Engineering Practice, the Grad.Brit.I.R.E. and A.M.S.E. Examinations, in addition to a wide range of non-examination courses in all branches of engineering—Radio and Electronics, Electrical, Mechanical, etc.

We also provide tuition for the Radio Amateurs' Examination and the P.M.G. Certificates for Radio Operators, with or without Morse training. Details are given in the handbook.

We definitely guarantee "NO PASS — NO FEE"

If you intend to make the most of today's opportunities, you cannot afford to miss reading "ENGINEERING OPPORTUNITIES." It tells you everything you want to know to secure advancement, and describes many opportunities you may now be missing through lack of information. Send for your copy today—FREE and without obligation.



BRITISH INSTITUTE OF ENGINEERING TECHNOLOGY  
369 COLLEGE HOUSE,  
29-31 WRIGHT'S LANE, LONDON, W.8

# BIET



## AN EXTRA EARPIECE FOR THE 706 TELEPHONE

Post Office approved, this STC telephone earpiece gives listening facilities for a second person on the new British Post Office 706 type telephone.

- Conversations can be recorded by stenographer
- Great time saver and *aide memoire* for the busy executive
- Earpiece disconnected when hung up
- No 'click' audible when earpiece is brought into use
- Listener can use extra earpiece when reception is weak or in noisy surroundings
- Exceptionally light and compact
- Now available in all 706 telephone standard colours—black, grey, ivory, green, red, yellow and blue.

Write, 'phone or Telex for Leaflet D/110. UK Subscribers connected to Post Office lines should apply to their Local Telephone Manager. Standard Telephones and Cables Limited, Telephone Switching Division, Oakleigh Road, New Southgate, London, N.11. Telephone ENTerprise 1234. Telex 21612.

world-wide telecommunications and electronics **STC**

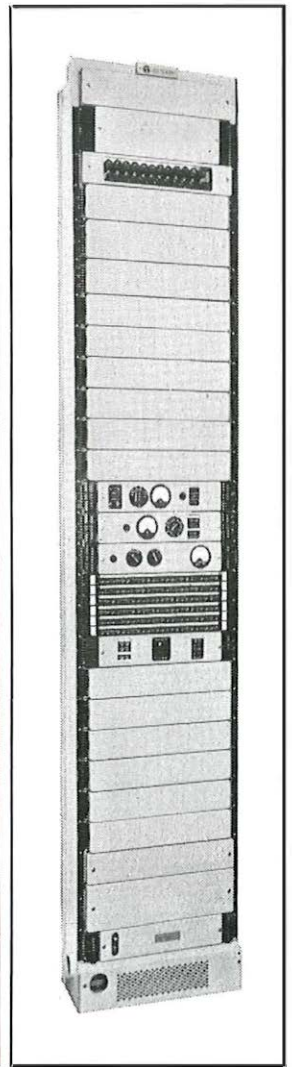
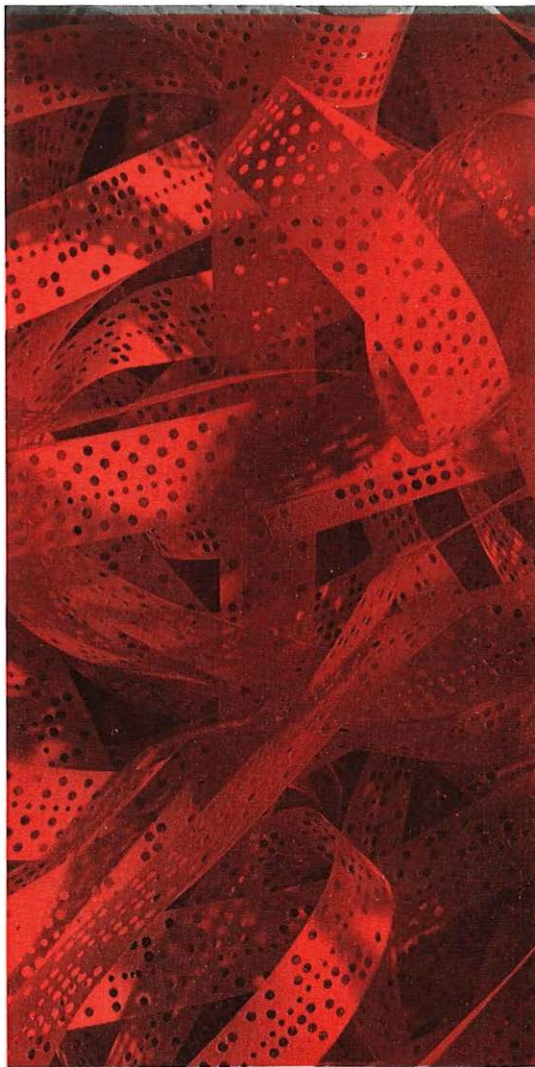
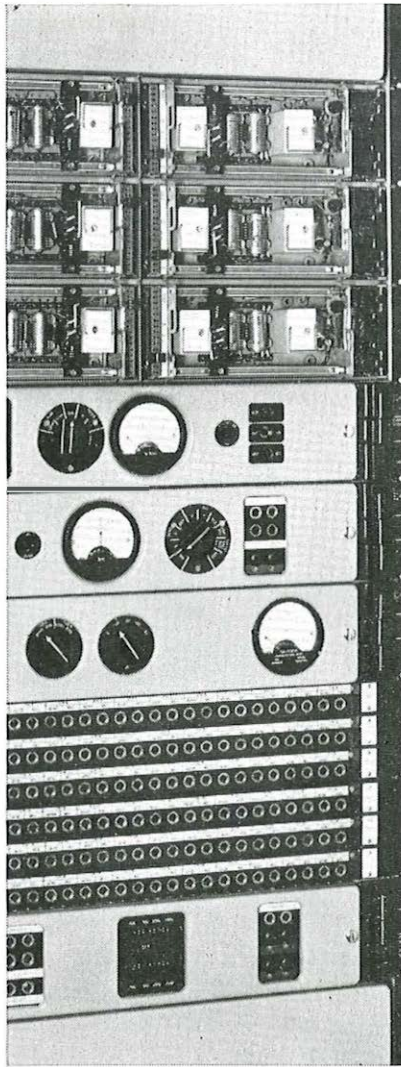

**TYPE TF8 24-CHANNEL V.F. TELEGRAPH SYSTEM** The TF8 is a new all-transistor system, using frequency-shift modulation. It provides up to 24 full duplex telegraph channels meeting CCITT recommendations for national and international teleprinter and Telex networks, and is designed to operate over long-distance land-line systems and stable s.h.f. and v.h.f. radio links. A special feature is pilot control to correct the incoming frequencies for up to 15 c/s of frequency drift arising in the bearer channels used. □ Telegraph speed: 50-75 bauds □ Channel spacing: 120 c/s in the audio range, 300-3 400 c/s □ Characteristic distortion: 50 bauds: 5% maximum, 75 bauds: 8% maximum □ Plug-in panels and one type of transistor throughout the transmission circuits simplify maintenance. Equipment for one complete terminal for 24 channels can be accommodated on a 9 ft. (2,74 m) rackside. Write, 'phone or Telex for Leaflet C/AE41. Standard Telephones and Cables Limited, Transmission Systems Group, North Woolwich, London, E.16. Telephone ALBERT Dock 1401. Telex 21645.

world-wide telecommunications and electronics **STC**



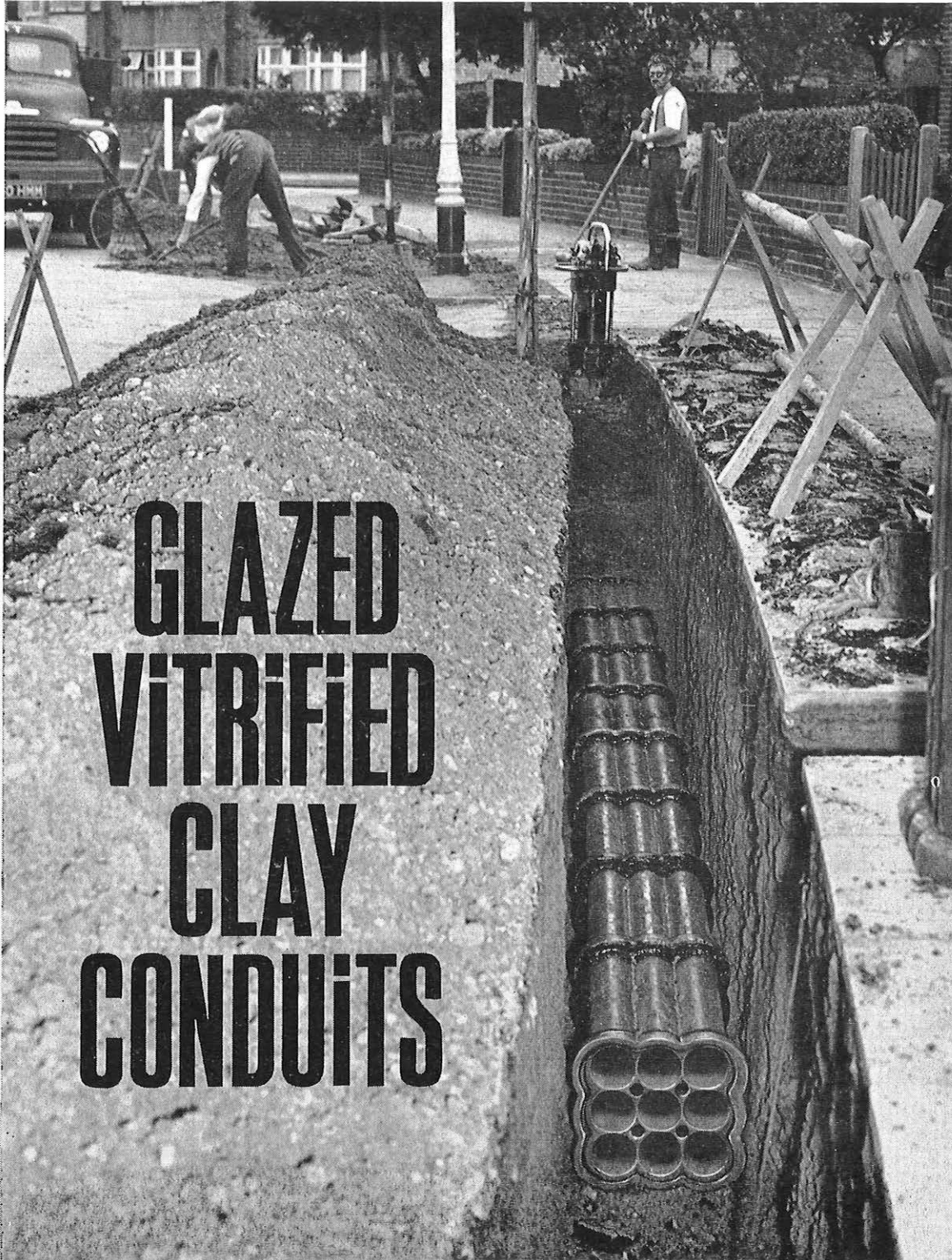

# GLAZED VITRIFIED CLAY CONDUITS

*Photograph by courtesy of  
H.M. Postmaster General.*

**... for underground security**

Our telecommunications, lighting systems and power lines are vital.  
For permanence, how right to use **glazed vitrified clay conduits**  
... there is no adequate substitute.

*write for further information to the Engineer*

**NATIONAL SALT GLAZED PIPE MANUFACTURERS' ASSOCIATION**  
125 New Bond Street, London W.1  
Telephone: **MAYfair 2763-4**



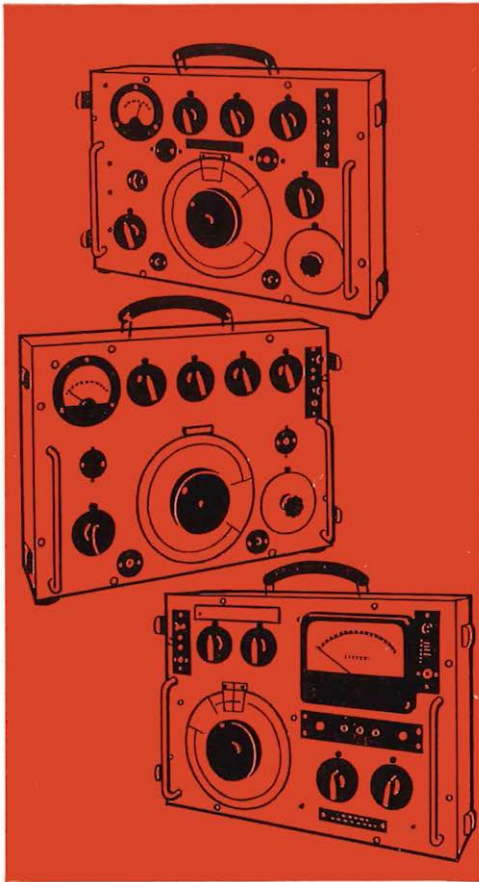

## TRANSISTORIZED RANGE OF TRANSMISSION TESTING APPARATUS

**FREQUENCY RANGE 30 c/s to 16 kc/s. 74186A Oscillator:** A general-purpose transistorized oscillator capable of delivering signals at levels of 0 to  $-80$  dbm into 600 ohm balanced and unbalanced circuits. In conjunction with the 74187A Receiving Unit it forms an equipment for making general transmission measurements in the audio-frequency range. **74187A Receiving Unit:** Will make flat (non-selective) through and terminated level measurements on 600-ohm balanced and unbalanced circuits down to  $-71$  dbm in the audio-frequency range. In addition, a high impedance (unbalanced) input circuit gives it a range of applications as a sensitive a.c. voltmeter. A circuit is also incorporated for feeding a recorder.

**FREQUENCY RANGE 4 kc/s to 610 kc/s. 74188A Oscillator:** A general-purpose heterodyne instrument meeting a wide range of requirements for testing multi-channel telephone systems. A feature of the oscillator is that it provides a signal for automatically tracking the associated 74189A Selective Level Measuring Set, thus ensuring that the selective circuit of the latter keeps in step with the oscillator output frequency throughout the frequency range. **74189A Selective Level Measuring Set:** For making selective measurements on multi-channel carrier telephone systems. It can be used for measuring tones in channels at group and supergroup frequencies and also line frequencies when adjacent channels are in traffic. These sets are portable and housed in light-weight carrying cases. They contain their own power supplies in the form of six  $1\frac{1}{2}$ -volt dry cells; alternatively an external 18-24 volt d.c. supply may be used. Write, Telephone or Telex for leaflets: Standard Telephones and Cables Limited, Testing Apparatus Division, Corporation Road, Newport, Mon. Telephone Newport 72281. Telex 49367.

world-wide telecommunications and electronics **STC**

**WHAT IS IT ?**

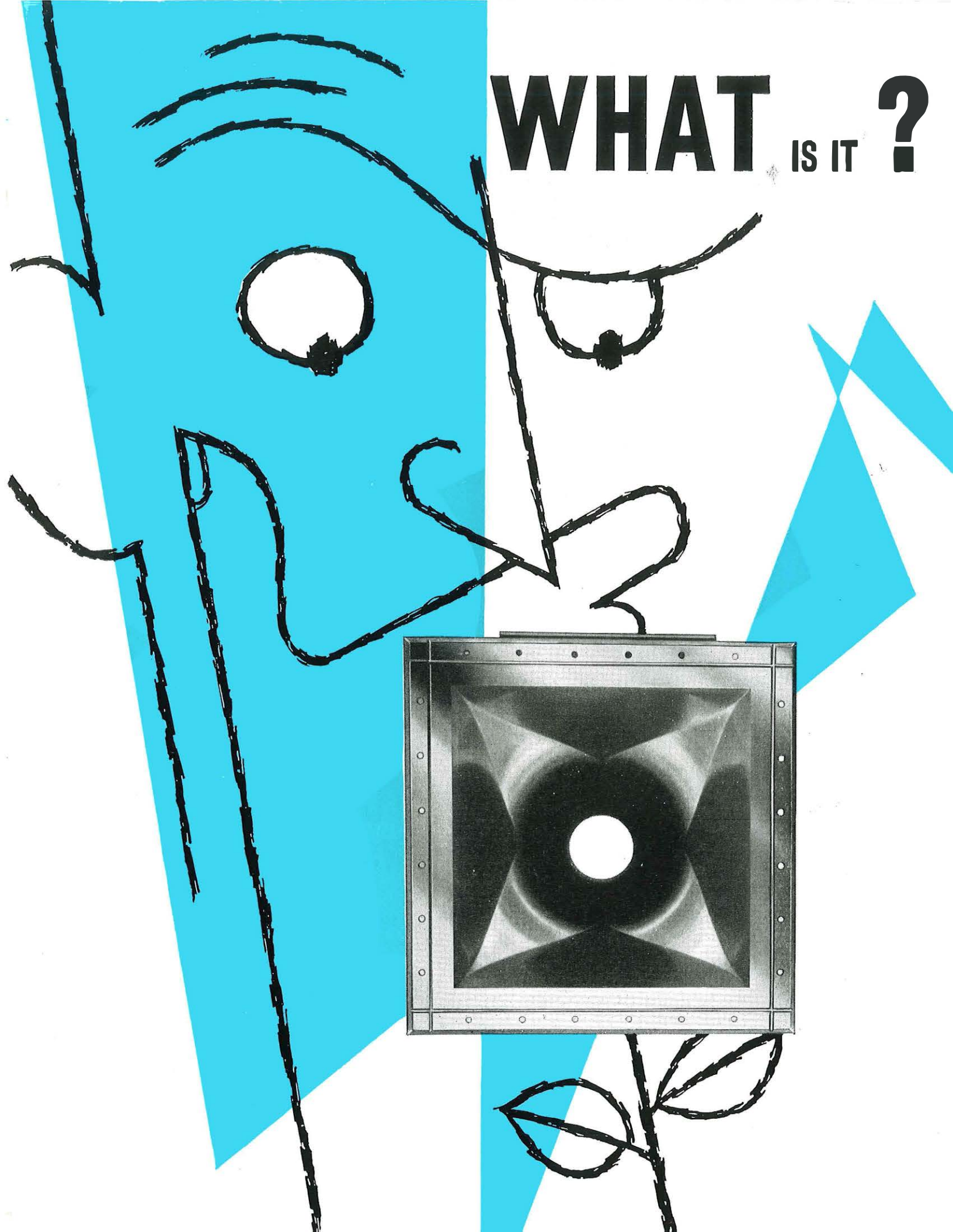

. IT IS

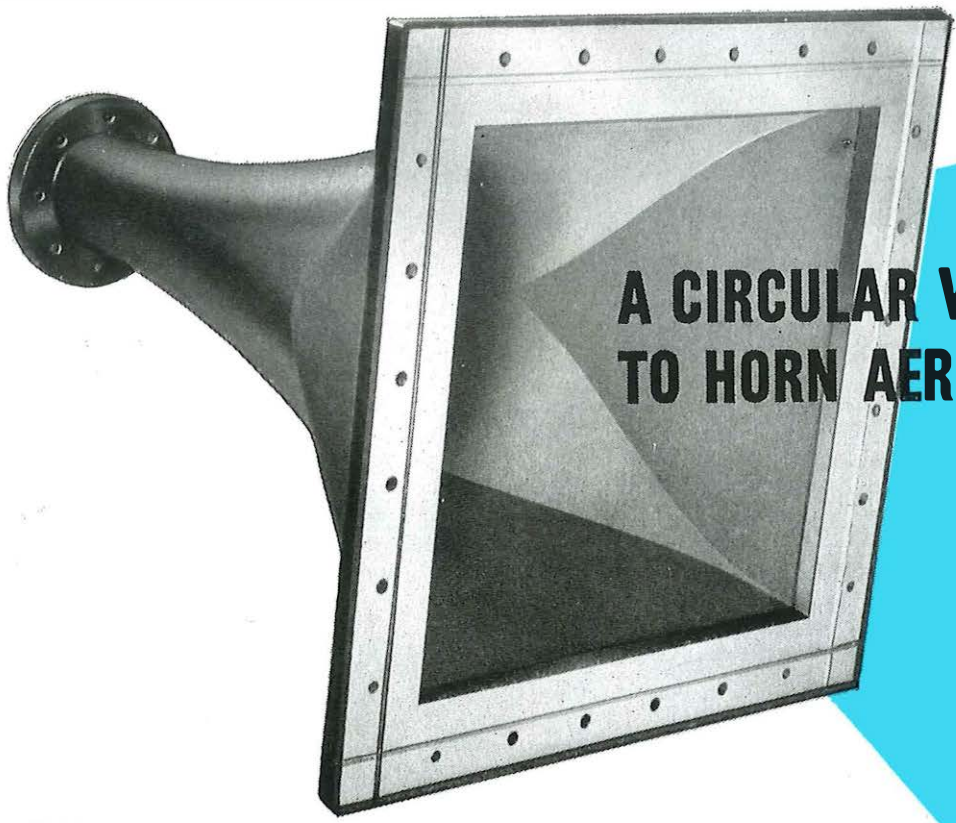

# A CIRCULAR WAVEGUIDE TO HORN AERIAL TRANSITION

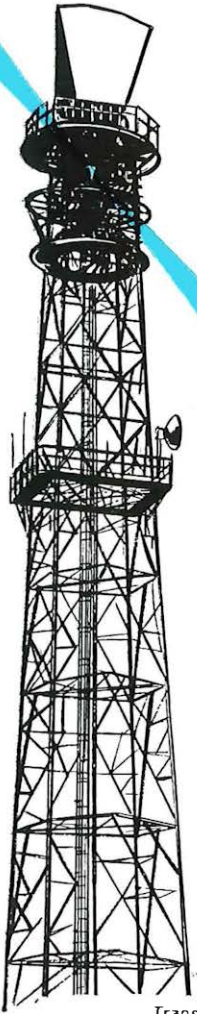

*Transmission Division*

## USED IN THE AERIAL FEED OF THE **G.E.C.** S.H.F MICROWAVE RADIO SYSTEM

The Circular Waveguide to Horn Aerial Transition is a length of non-uniform waveguide with an internal cross-sectional form which smoothly transforms along its length from a 2.812 in. diameter circle at one end to a 12 in. square at the other end.

The transition forms a suitable connexion between the horn aerial and circular waveguide feeder used in G.E.C. SHF Microwave radio systems.

**G.E.C. (TELECOMMUNICATIONS) LIMITED** · Telephone Works · Coventry · England · Works at Coventry, Middlesbrough & Treforest





RECTIFIER EQUIPMENTS FOR ALL  
TELECOMMUNICATION  
APPLICATIONS

PLEASE WRITE AND GIVE DETAILS OF YOUR PARTICULAR APPLICATION  
TO P.O. E1/64 RECTIFIER DIVISION, EQUIPMENTS DEPARTMENT  
**WESTINGHOUSE BRAKE AND SIGNAL CO LIMITED**

82 YORK WAY · KINGS CROSS · LONDON N1 · TERMINUS 6432 · TELEX No. 2-3225

# THE MARCONI HU126

**SELF CONTAINED  
7-UNIT MONITOR  
PROVIDES  
MONITORING OF  
ARQ AGGREGATE  
SIGNALS\*  
INDEPENDENTLY OF  
THE ARQ TERMINAL**

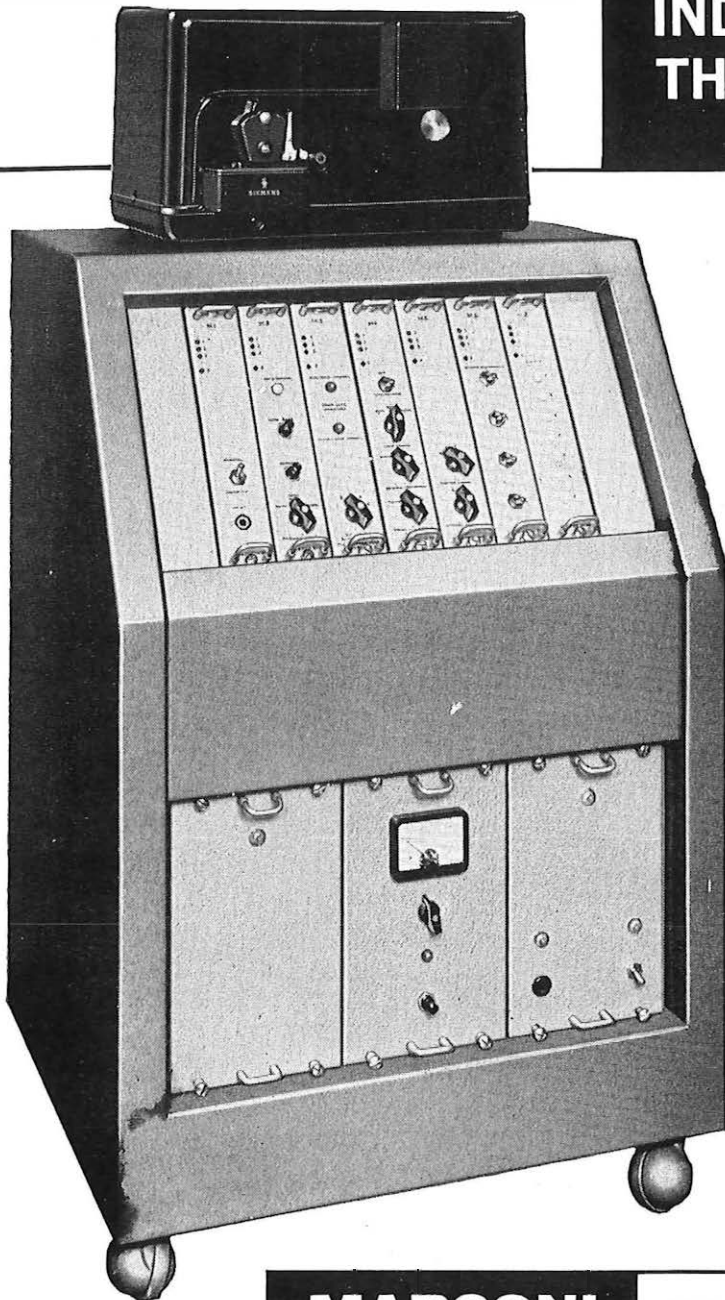

- Automatic phasing
- Self-synchronizing
- Printed record of any channel or any sub-channel.

The HU126, an item in the Marconi AUTOPLEX range of error correcting multiplex telegraph equipment, is Ferritristorized and uses modular construction. Being a self-contained unit with its own power supplies and crystal oscillator, it can be used with any type of ARQ equipment\* and quite independently of the ARQ terminals.

\* in accordance with CCIR  
Recommendation No. 242 and/or Report No. 108  
(Los Angeles 1959)

**MARCONI**

**TELECOMMUNICATIONS SYSTEMS**



# G.E.C. MICROWAVE RADIO NETWORK FOR GREECE

The G.E.C. has been awarded a contract by the Hellenic Telecommunications Organisation for the supply of SHF and UHF microwave radio systems. The main route consists of two bothway SHF channels between Patras and Michalakades with a baseband switching station at Thyrrion. There are two intermediate repeater stations, one between Patras and Thyrrion and the other between Thyrrion and Michalakades. A spur route using similar equipment will be installed between Thyrrion and Ioannina with an intermediate repeater station. The equipment will operate in the 6000 Mc/s band and each radio channel will carry up to 960 speech circuits. One radio channel will be used as a standby and will be switched into service automatically should the working channel fail or become degraded.

In addition, two systems will be provided using U.H.F. microwave radio equipment operating in the 2000 Mc/s frequency band. These are between Michalakades and Kerkyra and between Thyrrion and Agrinion. Again, two radio channels will be provided on each route with automatic changeover in the event of failure or degradation of the working channel.

A comprehensive supervisory and engineers' order wire facility is provided on all routes. On the main routes and the Ioannina spur, a separate S.H.F. auxiliary channel is used while on the U.H.F. routes, use is made of the lower part of the baseband spectrum for these facilities.

The switching arrangements are such that the systems can be expanded for multi R.F. channel operation, as required, at a later date.

*All the equipment conforms to C.C.I.R. recommendations.*

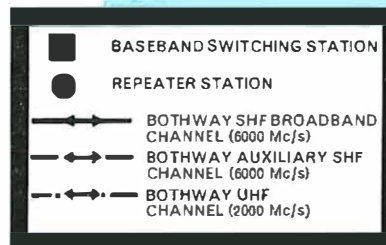

## EVERYTHING FOR TELECOMMUNICATIONS

TRANSMISSION DIVISION

**G.E.C. (TELECOMMUNICATIONS) LIMITED**

Telephone Works · Coventry · England

*Works at Coventry · Middlesbrough & Treforest*

*G.E.C. Distributor in Greece :- Christodoulou Bros Technical Co. Athens*





## Improved 'Rural Radio' for versatile Cross-Country Communications

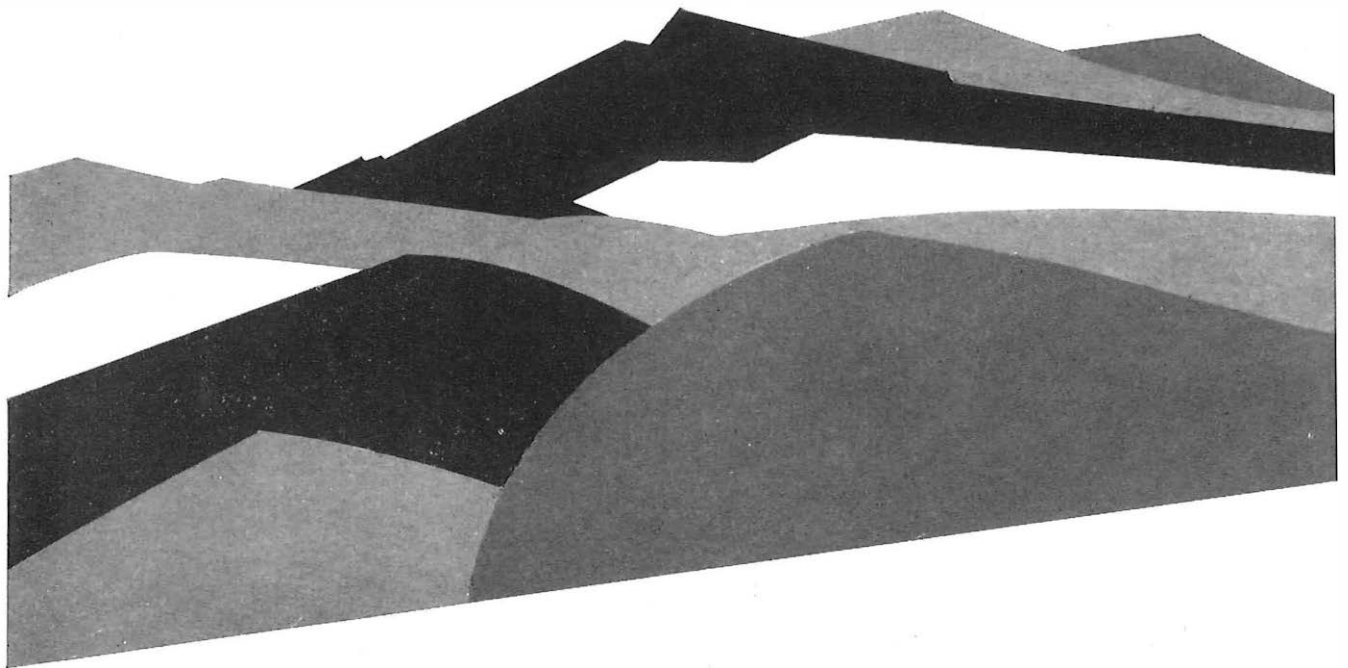

### Type 800 UHF/VHF Radio Telephone Systems

The Type 800 single channel radio telephone system is an improved version of the well-known AT&E 'Rural Radio' and offers substantial economies both in installation and maintenance costs wherever the terrain prohibits the use of cables or overhead lines. The equipment is completely compatible with the existing range of AT&E telephone equipments, and signalling and relay sets are available which permit suitable termination of virtually any type of telephone, exchange or switchboard.

The equipment is contained in a single terminal rack and operates in the UHF and VHF bands

with a maximum frequency of 500 Mc/s.

The power output ranges from 6 watts to 150 watts according to requirements. The equipment is narrow band apparatus and high stability performance permits operation on adjacent channels spaced only 25 kc/s apart. Normally the use of aerial diplexers permits single aerial operation.

The Type 800 equipment is just one of a wide range of communication equipments built by AT&E, who also offer a comprehensive planning, surveying and installation service.

If you would like more details, please write to:

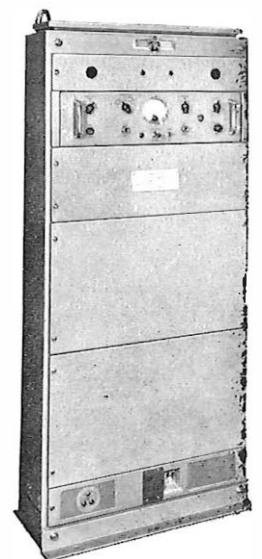

AT&E (Bridgnorth) Ltd · Bridgnorth · Shropshire · England





## is one speech channel enough?

your H.F. radiotelephone circuits are pushed to the limit or if you find new planning difficult—you need **Rediflex** for maximum utilisation and lower operating costs. Now for the first time, at low capital cost, Redifon produce a compact ISB multi-channel system for short and medium distance communication. Four speech channels simultaneously using one carrier. The cost of the transmitting and receiving terminals, including the channelling, is far less than you would pay for regular channelling and displacement equipment—a quickly installed packaged deal. It will pay you to find out more about Rediflex. Write now for full specifications.

## The Rediflex system gives you

• **four simultaneous speech channels**, or any combination of speech, teleprinter, facsimile or tone intelligence signals.

• **four crystal controlled spot frequencies**, 2 to 16 Mc/s.

• **1000 watts p.e.p output**, continuous rating (or 750 watts in the GA.406 amplifier).

• **compatible** with Standard International ISB systems.

• **completely transistorised** receiving terminal and transmitter drive unit.

• **modular construction** and printed circuits.

• **alternative power supply units** for a.c. mains or **24 volts dry cell supplies**.

# *Redifon*

REDIFON LIMITED Communications Sales Division  
Broomhill Road, London, S.W. 18. Telephone: VANdyke7281  
A Manufacturing Company in the Rediffusion Group.  R&2

# ROME WAS NOT BUILT



# IN A DAY...

... nor can electronic switching systems be developed overnight. But G.E.C. development is continuous. At Telephone Works a co-ordinated development programme is progressing rapidly, with electronic exchange designers building on the firm foundation laid over many years by the designers of the present most modern step-by-step systems.

G.E.C. electronic exchanges will provide more extensive and flexible facilities than have previously been possible, while taking advantage of the inherent reliability of electronic components. Electronic switching techniques cannot be overlooked in the present planning of future exchange systems.

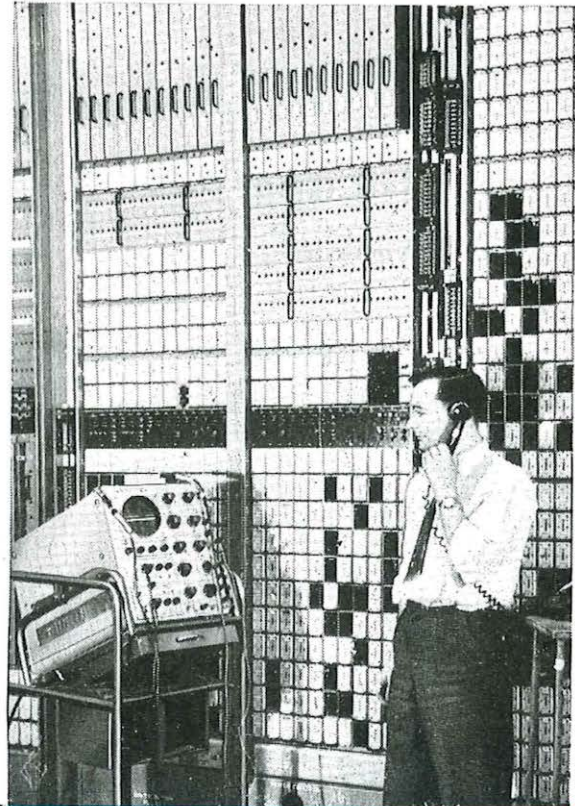

**S.E.C.**

**EVERYTHING FOR  
TELECOMMUNICATIONS**

*Exchange Division*

**S.E.C. (TELECOMMUNICATIONS) LTD • TELEPHONE WORKS • COVENTRY • ENGLAND**

*Works at Coventry • Middlesbrough and Treforest*

*Smee's 1.50*



# TMC transistorised carrier equipment CHOSEN BY KUWAIT

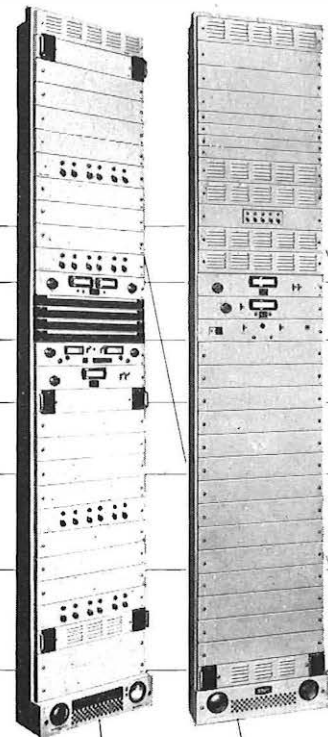
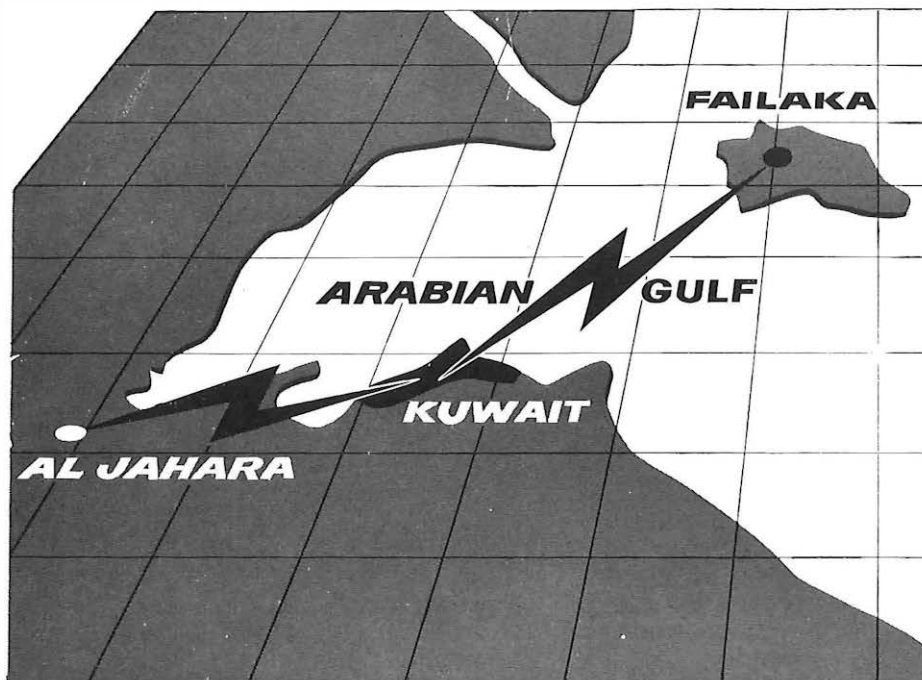

The transistorised multi-channel carrier telephone and telegraph link equipment for Kuwait consists of:

|            |            |
|------------|------------|
| TMC        | TMC        |
| 24 CIRCUIT | 24 CIRCUIT |
| VF         | CARRIER    |
| TELEGRAPH  | TELEPHONE  |
| TERMINAL   | TERMINAL   |
| EQUIPMENT  | EQUIPMENT  |
| TYPE T24D  | TYPE R24C  |

For important trunk connections between Al Jahara, Kuwait and Failaka, the Kuwait Ministry of Posts, Telegraphs and Telephones selected these TMC terminals. The equipment is ideally suitable for reliable and economical service over a long working life under arduous climatic conditions.

*Fully informative literature on both equipments is available from TMC. Write for leaflet F 3616 (T24D) or F 3663 (R24C).*



**TELEPHONE MANUFACTURING COMPANY LIMITED**

Transmission Division, Dept. X  
Sevenoaks Way · St. Mary Cray · Orpington · Kent · England · Tel: Orpington 27020

A MEMBER OF THE  GROUP OF COMPANIES



# WESTINGHOUSE



## SEMICONDUCTORS FOR ELECTRONICS

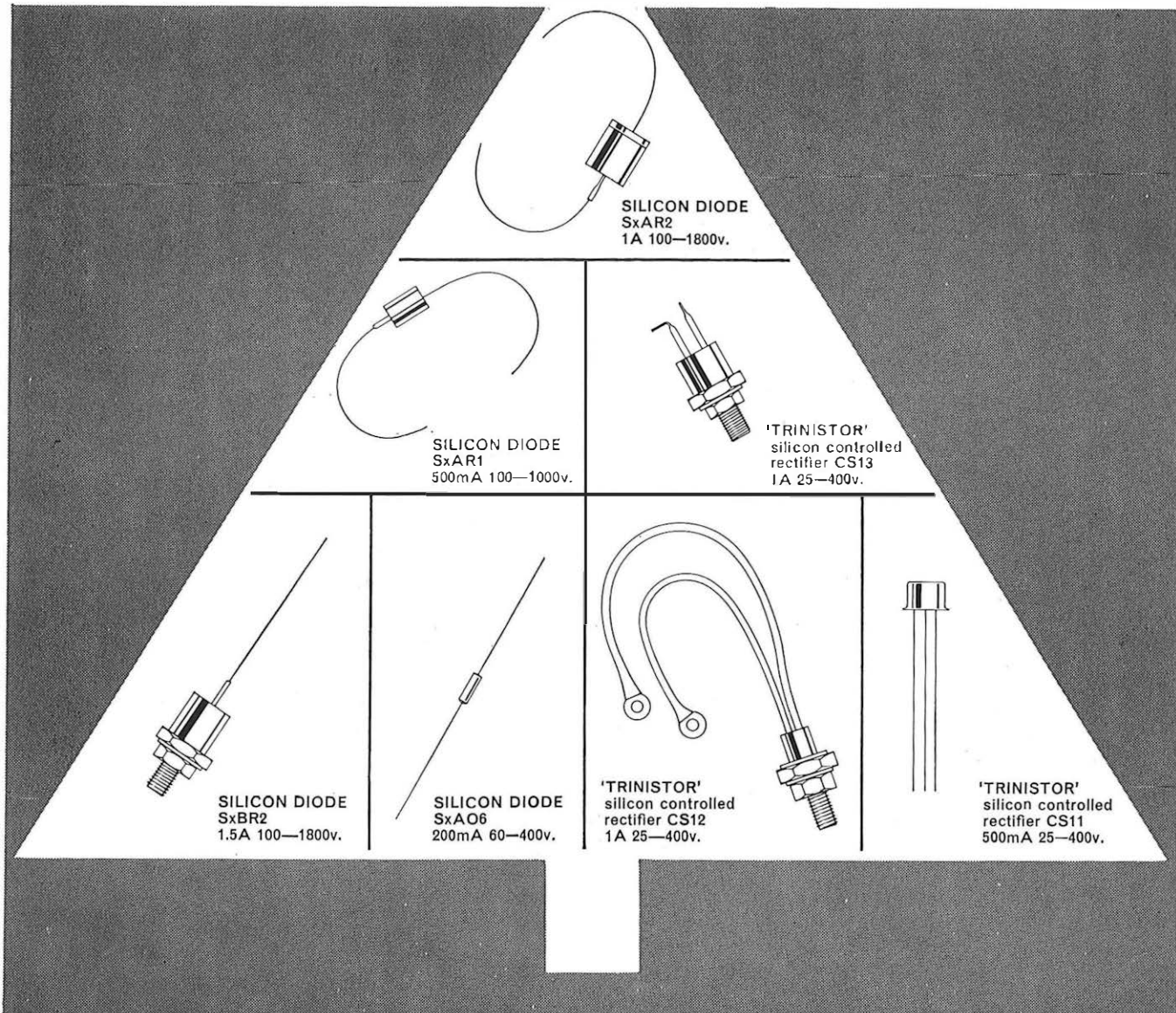

Please write for full details to: Dept PO.S1/64 Rectifier Division, Semiconductor Dept.

### WESTINGHOUSE BRAKE AND SIGNAL COMPANY LIMITED

82 York Way, King's Cross, London, N.1. Tel: TERminus 6432 Telex No. 2-3225

# a tradition of progress...

Long before the 'automation' era, the telephone engineer was quietly supplanting manually performed tasks with automatic machines of considerable refinement.

The progressive approach of AEI designers has become traditional by their participation at every stage in the steady development of the electro-mechanical telephone switching systems of today.

Typical of their latest developments is a system of Automatic Number Identification which swiftly and surely locates a calling line and conveys the number to automatic trunk ticketing equipment at a distant centre.

Adaptable for several purposes, this equipment takes every advantage of electronic components and compact construction, and provides a foretaste of the suitability of these techniques for the needs of tomorrow.



**AEI**

## Telecommunications Division

Public Telephone Systems Department

Woolwich, London, S.E.18

Associated Electrical Industries Limited

# TRANSISTOR SUPPLY PROBLEMS



## SPRAGUE®

THE MARK OF RELIABILITY

MADT, PNP, SPAT, MAT, ECDC

# TRANSISTORS

NOW AVAILABLE IN BRITAIN

2N14  
1500 2N1  
2N 2398 2N  
2N 1499 2N  
501A 2N50  
398 2N14  
2N 976 2N  
2N 2360

Previously manufactured by  
Philco International,  
these high quality  
transistors are now  
made available to the  
British market by T.C.C.

with the co-operation  
of their American  
associates, Sprague  
Electric Company.

2N 1500 2N 2048 2N 1742  
2N 2401 2N 502 2N 1742  
360 2N 2398 2N 501 A 2N  
2N 976 2N 2401 2N 1500 2N  
1742 2N 2360 2N 2398 2N  
2N 502 2N 1742 2N

Solve your particular  
transistor problem by writing  
to us at Acton for further  
details of this latest product of  
the T.C.C. Sprague association

2N 501A 2N  
2N 1499A 2N 1500  
502 2N 1742 2N 23  
2N 2398 2N 1499  
2N 1499

## THE TELEGRAPH CONDENSER CO LTD

(Head Office & Works)  
North Acton · London · W3  
Tel: ACOrn 0061 (16 lines)  
Telex 261383

(also at)  
CHESSINGTON · SURREY  
BATHGATE · SCOTLAND

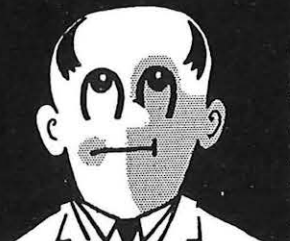

## ROOTES TEMPAIR

# AIR CONDITIONING

AIR at its best, temperature  
controlled and cleaned. Air  
with that natural outdoor  
quality that only REAL air  
conditioning gives you.

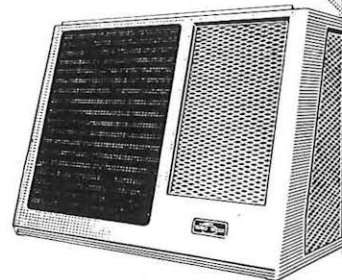

### FOR CELLARS

Rootes Tempair Cellar  
Cooler maintains an even,  
natural temperature.

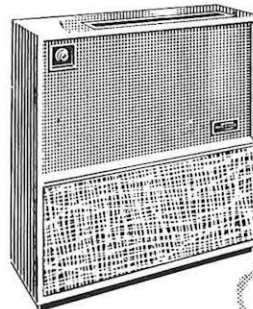

### BOARDROOMS

Rootes Tempair Director free-  
standing unit delivers heated  
or refrigerated air, cleans and  
dehumidifies. Quiet running.

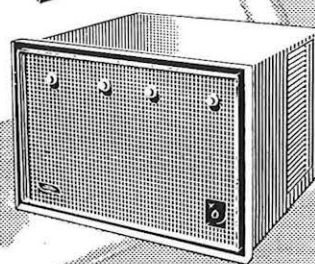

### FOR BUSINESS

Rootes Tempair Pacific, window  
or wall models. Modern styling,  
complete and efficient air-condi-  
tioning. Freedom from noise  
and dust.

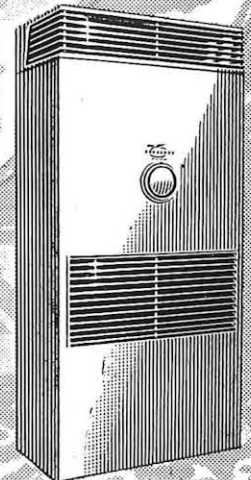

### AND INDUSTRY

Rootes Tempair '5000' Industrial  
air-conditioning for laboratories, computer rooms, small  
workshops, etc. High output, water or air cooled,  
economical in floor space.

Send this coupon today for details of range

To: **TEMPAIR LIMITED · ROMNEY PLACE · MAIDSTONE  
KENT · ENGLAND** A Rootes Group Company.

Tick whichever applicable

Name \_\_\_\_\_

Address \_\_\_\_\_

- CELLAR COOLER
  - DIRECTOR
  - PACIFIC
  - TEMPAIR '5000'
- CUPO 2

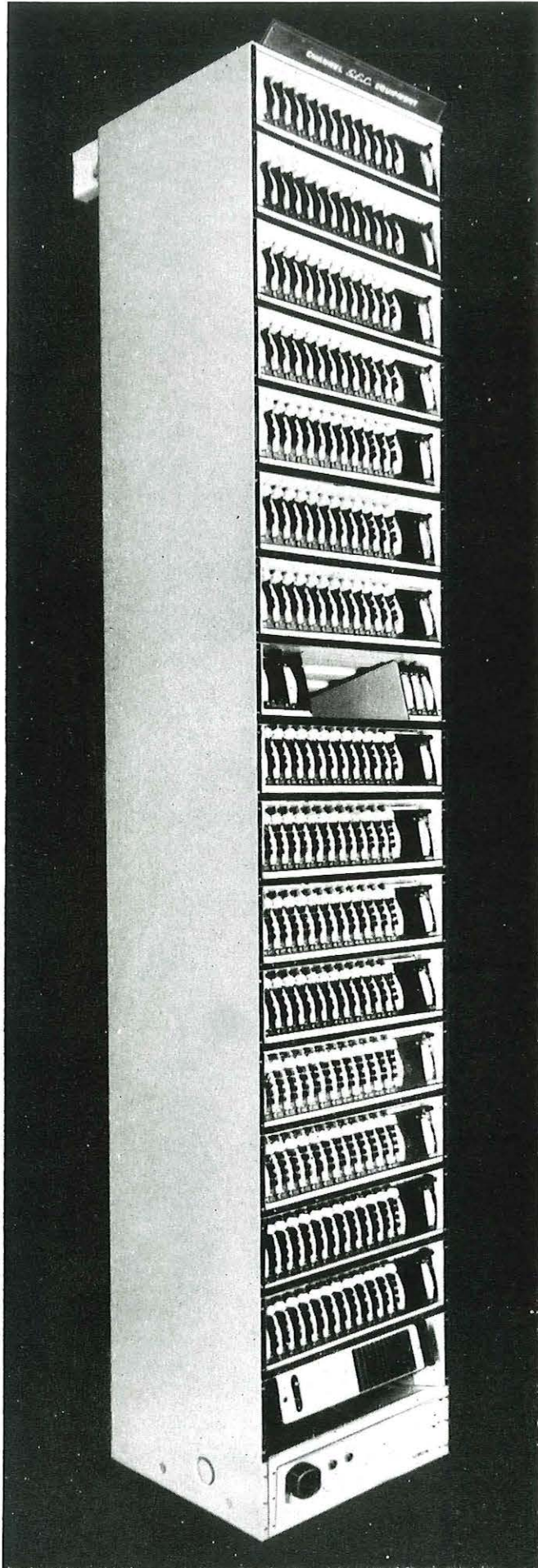

▲ 9 ft. C.A.S.E. Channel Rack

# CASE

C.A.S.E. (Card Assembled Shelf Equipment) is an entirely new construction practice for transmission equipment that takes full advantage of recent developments in components, materials and production techniques. At the same time, C.A.S.E. is compatible with the existing equipment produced by G.E.C. and conforms to the general dimensions recommended by C.C.I.T.T. A C.A.S.E. rack can be installed in an existing standard rack suite with up to 23% space economy over existing double-sided rack designs. In new stations, the economy achieved can be as much as 44%.

**EVERYTHING FOR TELECOMMUNICATIONS**



C.A.S.E. Shelf

Most transmission equipment practices require the purchase of a number of pre-wired and assembled racks, even though initially only a small proportion of the space may be occupied by equipment. With C.A.S.E., however, no pre-wiring is required and a given framework can accept standard shelves of equipment mounted as required for a particular installation. The cost of the initial installation, therefore, may be kept to a minimum without prejudicing future requirements.

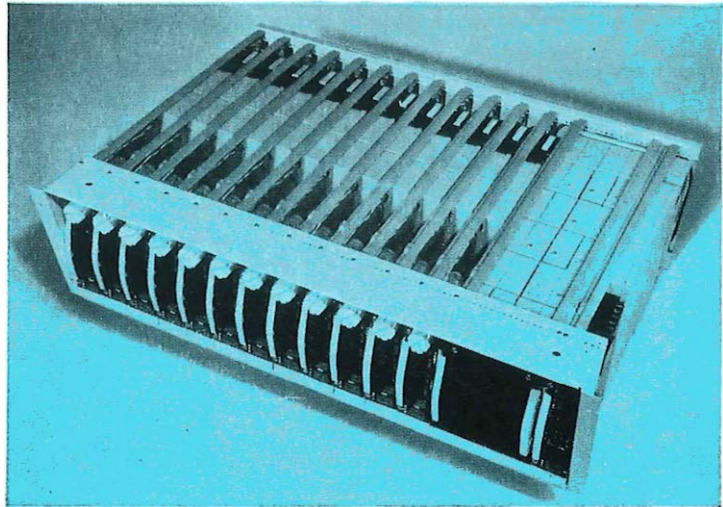

## A NEW CONSTRUCTION PRACTICE FOR TRANSMISSION EQUIPMENT

Using C.A.S.E. techniques, installation is greatly simplified. At an early stage, the frameworks can be shipped to site from stock and the inter-rack cabling can be run and cut to length. Next the shelves, pre-wired and tested at the factory, are shipped and installed and the wiring to power supplies and external connections are completed on site. Finally, the cards are supplied and need only be plugged into their respective shelves.

As the construction of a C.A.S.E. card is such that all components are mounted on one side of the board and all wiring on the other, access to all components is made easy by the simple removal of the card from the shelf. A Test Adaptor or Outrigger enables maintenance to be carried out on a working circuit.

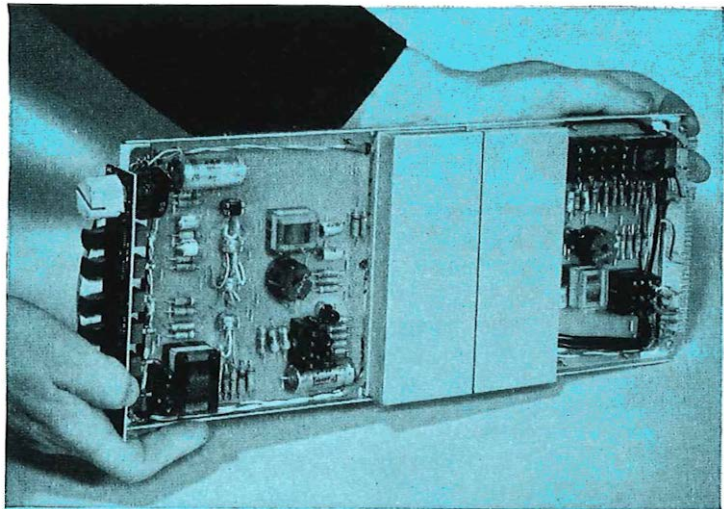

C.A.S.E. Channel Card



*Transmission Division*

**G.E.C. (TELECOMMUNICATIONS) LIMITED**

Telephone Works · Coventry · England

Works at Coventry · Middlesbrough & Treforest

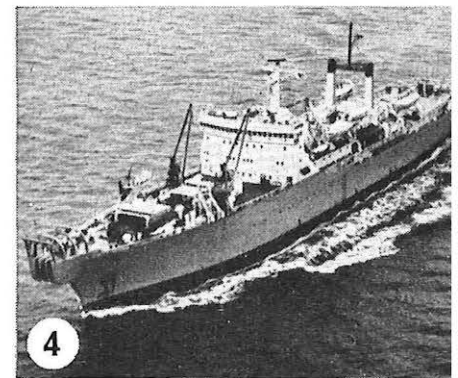
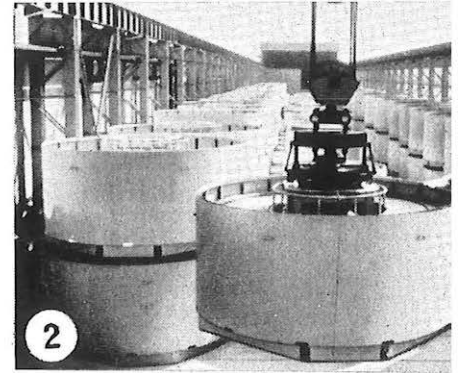
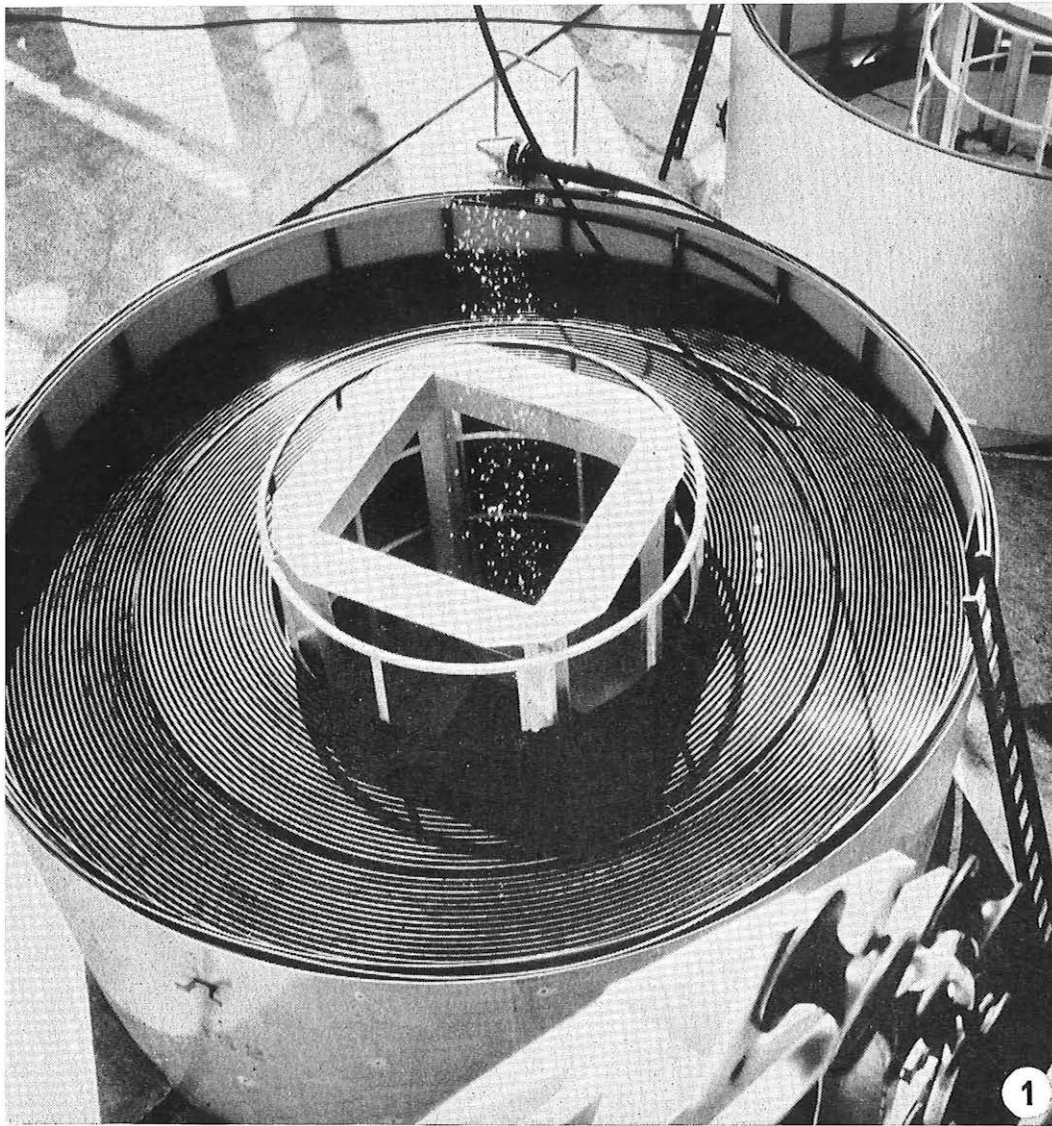

# the world's longest undersea cable is RIGIDEX protected

TAT-3 signifies 3,600 nautical miles of the most precisely specified and accurately manufactured submarine telephone cable yet produced. All the materials used were the best of their kind and the use of Rigidex for the outer sheath is a significant tribute to this high density polyethylene. The message this underlines is clear—a polyethylene good enough to protect the latest and longest undersea telephone cable will give quality and saleability to YOUR products. For full information about Rigidex ask BRP for their Booklet (Ref. 328).

*TAT-3 is the first direct telephone cable link between Britain and the USA. It is a joint Anglo-American project and cable for the contract has been manufactured at Southampton by Standard Telephones and Cables Ltd.*

**1** COMPLETED CABLE AWAITS SHIPMENT **2** TAT-3 IS STORED IN TRANSPORTABLE STEEL TANKS **3** TRANSFERRING TAT-3 TO THE CABLE SHIP **4** AMERICA'S NEWEST AND BIGGEST CABLE LAYING SHIP 'LONG LINES'

Sole Selling Agents

**British Resin Products Ltd**  
A COMPANY IN DISTILLERS CHEMICALS AND PLASTICS GROUP



Rigidex is a reg'd trademark of British Hydrocarbon Chemicals Ltd. and one of the products they manufacture at Grangemouth.

SALES AND TECHNICAL SERVICE DEVONSHIRE HOUSE PICCADILLY LONDON W1 HYDE PARK 8131

*Distillers Plastics Serve Everyman*

# ADCOLA

ESTABLISHED 1911  
(Royal Warrant)

## SOLDERING INSTRUMENTS and EQUIPMENT

Illustrated

L64  $\frac{3}{16}$ " DETACHABLE  
BIT MODEL IN  
PROTECTIVE  
SHIELD L700  
FITTED WITH  
ACCESSORIES FOR  
BIT CLEANING, ETC.

ALL VOLT RANGES  
6/7 to 230/250 VOLTS

British and Foreign  
Patents and Registered  
designs

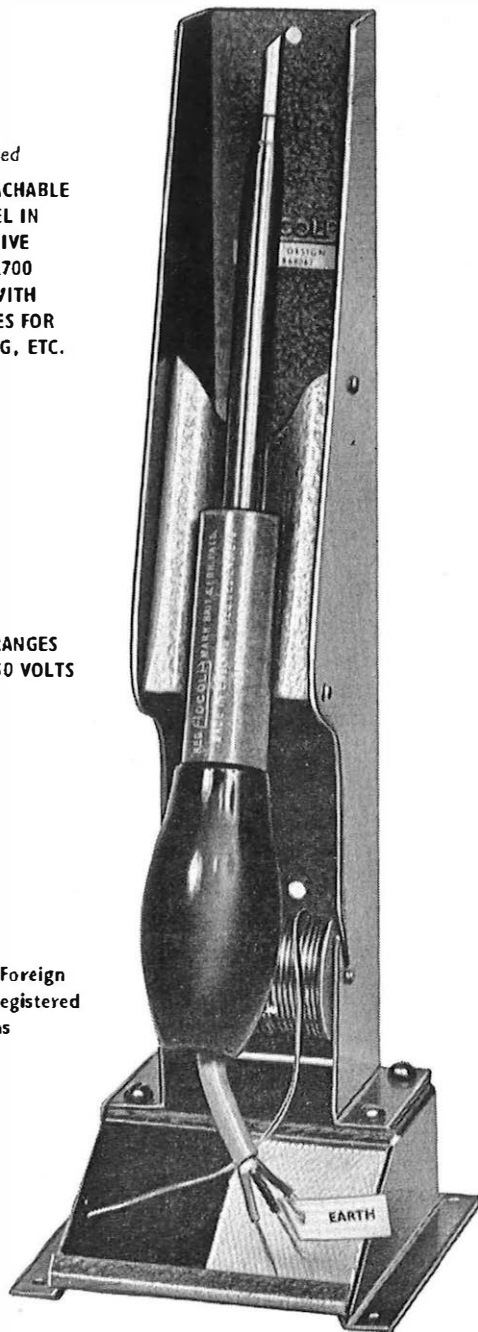

For further information and full illustration catalogue apply head office

**ADCOLA PRODUCTS LIMITED**  
ADCOLA HOUSE, GAUDEN ROAD,  
LONDON, S.W.4

Telephones:  
MACaulay 3101 and 4272

Telegrams:  
SOLJOINT, LONDON, S.W.4

# WHITELEY

## Epoxy Resin Mouldings

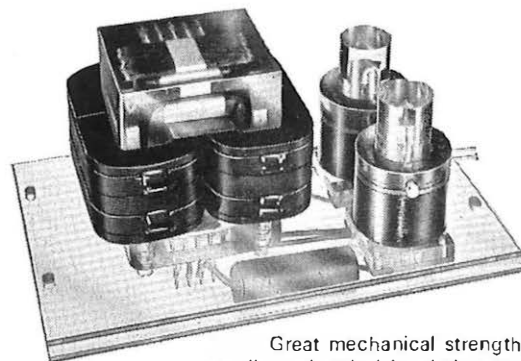
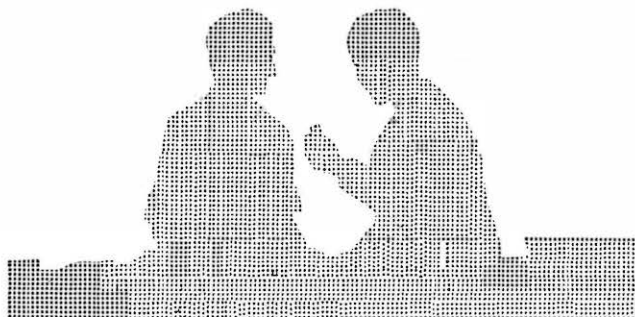

Great mechanical strength, excellent electrical insulation and complete climatic protection are ensured in Whiteley Epoxy Resin mouldings. Low shrinkage and strong adhesion to components and leads renders these Resins particularly suitable for encapsulation. Full details will be gladly sent on request.

## Fixed-Frequency Oscillator

Built on a standard octal base and encapsulated in epoxy resin, this Fixed-Frequency Oscillator incorporates an adjustable core permitting slight tuning either side of the fundamental frequency. Output: 10mW into a 600 ohm load. Frequency: As required between 400-10,000 c.p.s. sinusoidal. Please write for full details to

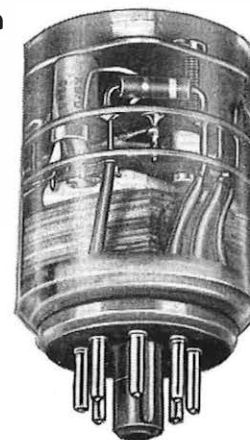

**WHITELEY** ELECTRICAL RADIO CO LTD

MANSFIELD · NOTTS Tel: Mansfield 1762/5



## Telecommunications is people talking . . .

. . . and **A.T.E.** have been talking communications for over half a century. In that time **A.T.E.** has grown from the small nucleus organisation that pioneered the **Strowger** system of automatic telephony in the **United Kingdom** to a world-wide network of companies — the largest manufacturers of telecommunications equipment in the **British Commonwealth**.

In the **U.K.** alone, the Company has one and a half million square feet of production space at its

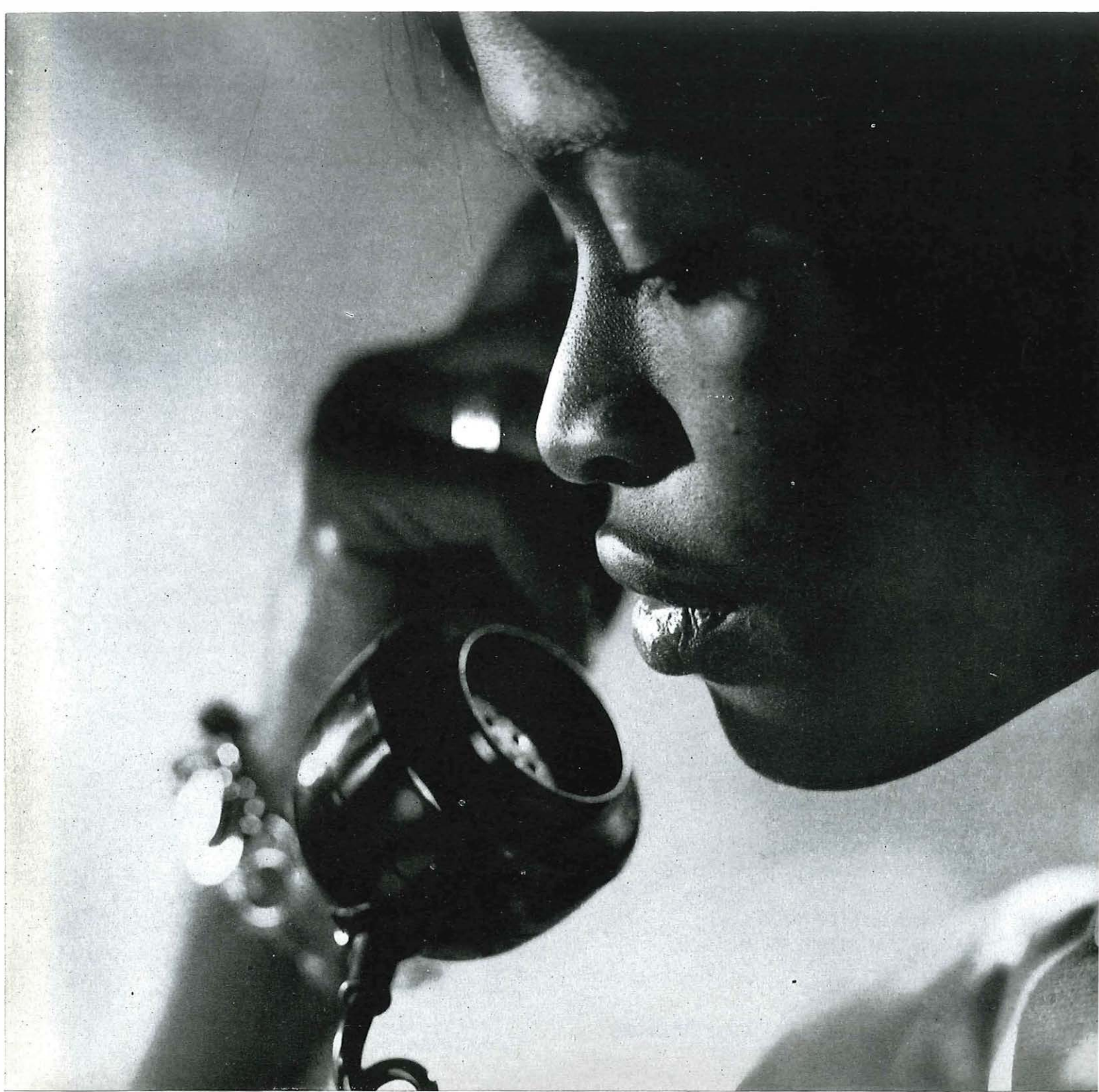

## across the world

disposal whilst, overseas, there are associated factories in Australia, New Zealand, South Africa, Portugal and Brazil.

The whole of the Company's research and development programme is centrally co-ordinated and the resultant cross-fertilisation of ideas and information is one of the main reasons why A.T.E. telecommunications equipment is the most advanced in the world.



8 ARUNDEL STREET · LONDON WC2 · *A Principal Operating Company of the Plessey Group*

# SUB- CONTRACT AS A BUSINESS

NOT A  
SIDE  
LINES

Such is our reputation in our original field, that many Government establishments and commercial organisations are unaware of our expertise in other branches of electronics and in light engineering.

Conversely, our many customers in the several other fields in which we work, are unaware of our abilities in the ultra high frequency field.

Our facilities, in fact, embrace:—

WAVEGUIDE COMPONENTS AND ASSEMBLIES  
MICROWAVE INSTRUMENTS  
MOTOR SPEED CONTROL  
HIGH POWERED AMPLIFIERS  
AUTOMATIC FREQUENCY AND VOLTAGE REGULATORS  
SEQUENCE AND TIMING CONTROLLERS  
PRECISION MECHANISMS, GEARBOXES  
ELECTRO-MECHANICAL DEVICES  
INSTRUMENT REPAIR AND CALIBRATION  
TECHNICAL EDUCATIONAL AIDS  
LANGUAGE LABORATORIES

In keeping with the general expansion which is taking place in the Sanders Group a new **SUB-CONTRACT DIVISION**

has been set up to control and organise all sub-contract work passing through the Group.

Design, development, production and calibration facilities are available not only in the field of high precision engineering where we are already well known, but also in the field of competitively priced quantity produced components and assemblies. The recent acquisition of an additional Factory in Stevenage, increases our ability to give you the delivery dates you require.

Our reputation as engineers of high quality products may have overshadowed our proven ability to produce in quantity, components and assemblies at competitive prices.

## Sanders Group of Companies

*Sub-Contract Division*

**Gunnels Wood Road · Stevenage · Herts · England**

Telephone: Stevenage 981

Telegrams: Sandelect, Stevenage

**SUB-CONTRACT** 

Telex: 82159 Sanders Stev.

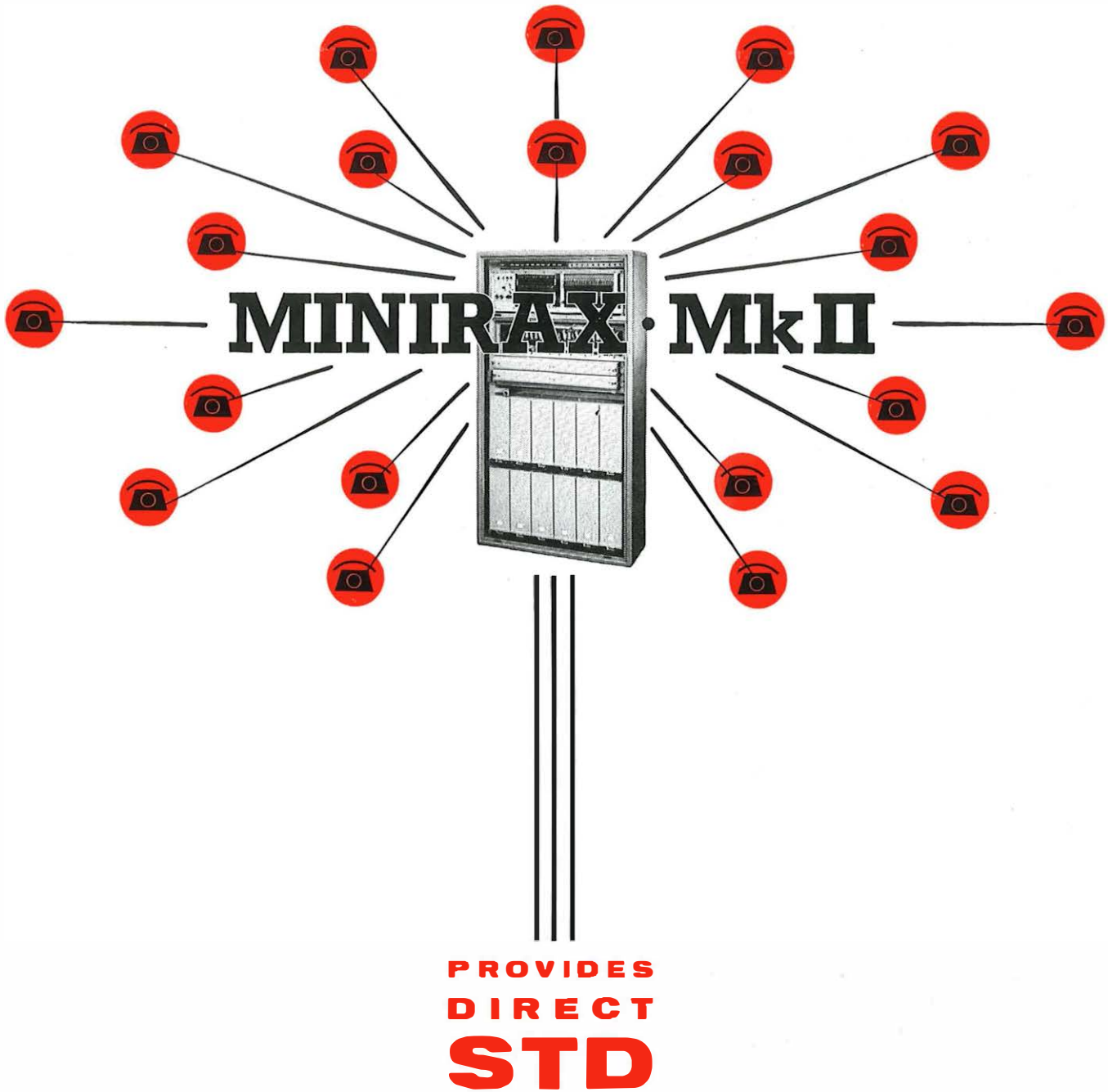

**for small isolated communities, specialized groups, fringe urban areas, rural areas**

Designed for working in relatively low-traffic density areas, the 20 line capacity Minirax Mk. II offers to remote subscribers the attendant advantages of S.T.D. The system utilizes straightforward step-by-step principles and together with a remotely chargeable 24 V. battery is completely self-contained in a compact, dustproofed metal case.

Minirax Mk. II can be connected directly into the nation-wide network over a physical junction pair; an additional two junctions being provided by transistor rural carrier apparatus in the exchange. Where

S.T.D. requirements are not immediate, the system may be commissioned as a dependent exchange. This can readily be converted to full S.T.D. working as required by the provision of the appropriate junction relay sets.

Minirax Mk. II can also provide S.T.D. facilities prior to completion of permanent exchange buildings or to meet the needs of specialized groups engaged in vital work in remote areas.

If you would like further details of the advanced Minirax Mk. II system write to the address below.

Head Office:  
 22 LINCOLN'S INN FIELDS · LONDON · W.C.2  
 Telephone: HOLborn 6936  
 A Principal Operating Company of the Plessey Group



**ERICSSON TELEPHONES LIMITED**  
**ETELCO LIMITED**



# Floor pattern Switchboard

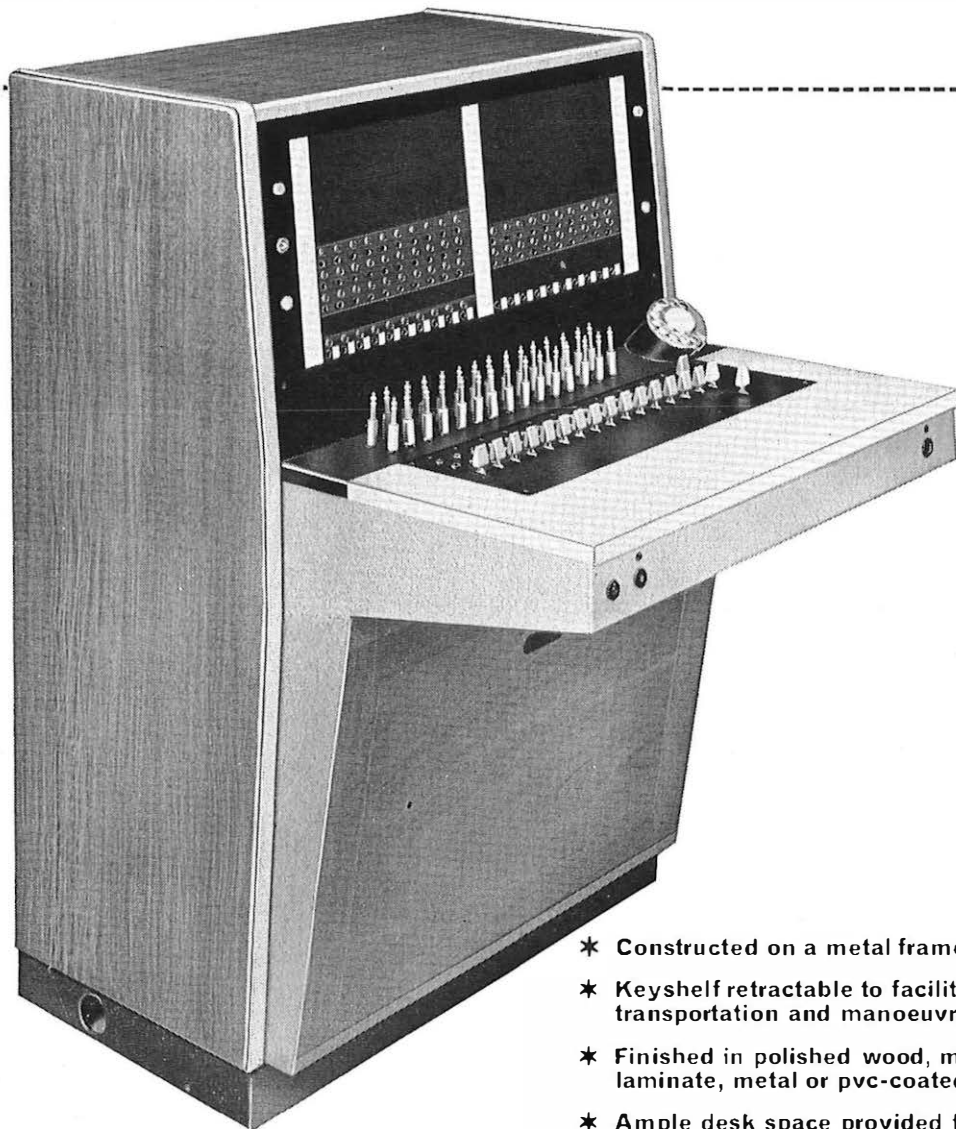

Distinguished both in appearance and performance this new TMC floor-standing switchboard embodies a number of new facilities and circuit features. This illustration of a typically equipped switchboard shows clearly the attractive businesslike appearance. A note on your operational requirements, together with an indication of the external finish you prefer, will bring you full details and quotations.

- \* Constructed on a metal frame.
- \* Keyshelf retractable to facilitate transportation and manoeuvring.
- \* Finished in polished wood, melamine laminate, metal or pvc-coated metal.
- \* Ample desk space provided for the operator.
- \* Available with lamp, indicator or magneto signalling.
- \* Keyshelf maintenance without interrupting switchboard operation.
- \* Supplied for tropical or temperate climate use.



**TELEPHONE MANUFACTURING COMPANY LIMITED**

Telephone Equipment Division · Public Equipment Unit

Martell Road · West Dulwich · London S.E.21 · Telephone GIPsy Hill 2211 · Telex 28115

A MEMBER OF THE  GROUP OF COMPANIES



## over thirty types—and all from stock!

The range of high-quality Broad Band Microwave Components offered by MEL now includes more than thirty units—all 'available from stock' all ruggedly constructed, all featuring very wide coverage and all of extremely compact design. It is from MEL's own extensive manufacturing and application experience—backed by world-renowned research facilities, that the range of microwave components has been developed, with new items of proven quality being continuously added to the list.

Extending in frequency from 1 to 11.5 Gc/s, in five bands, the range of components includes hybrids, isolators, filters and circulators—in waveguide, stripline or co-axial form.

Behind the production of each item lies a microwave problem already effectively solved by MEL, and within the range, there may lie the 'ready made' solution to one or many of your own microwave problems.

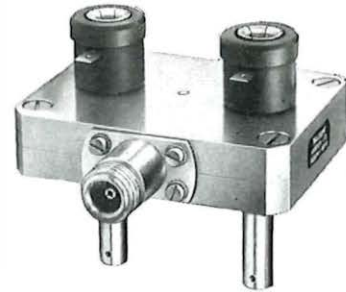

Write for Microwave Components Catalogue to:  
**MULLARD EQUIPMENT LIMITED**

Manor Royal · Crawley · Sussex · Telephone: Crawley 28787

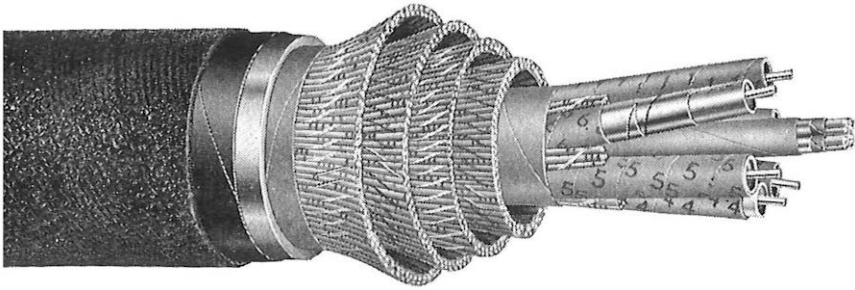

#### **TYPE 375 COAXIAL CABLE**

For television circuits and multichannel telephony, BICC manufacture cables containing coaxial pairs meeting the C.C.I.T.T. recommendation G.334. These can be combined with symmetrical pairs for audio frequency or short-haul carrier circuits.

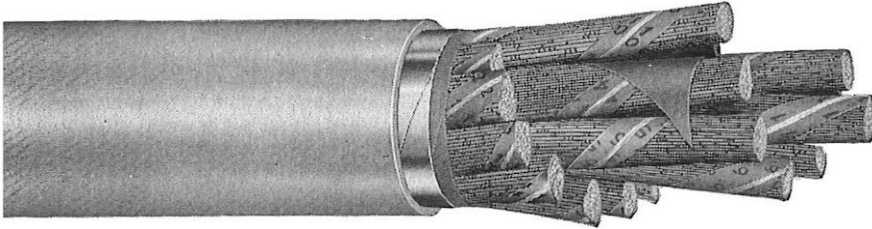

#### **UNIT TWIN CABLE**

Large cables of unit construction are specially suited to the systematic arrangement of a dense telephone subscriber network. Units of 50 or 100 pairs are first assembled, then the required number of units are combined and sheathed to form the complete cable.

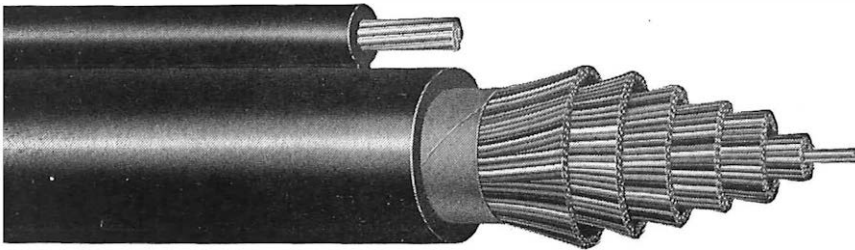

#### **POLYTHENE INSULATED DISTRIBUTION CABLE**

Because of their ease of installation, reliability and low cost, polythene insulated distribution cables are widely used, particularly in sizes up to 100 pairs. They may be installed underground or, as in the case of the type illustrated, used with an integral suspension strand wherever aerial installation is preferred.

# BICC

# TELEPHONE

are designed and manufactured to meet C.C.I.T.T. recommendations or any other specific requirements. They are the products of modern plant, specialist engineers and over sixty years of experience—backed by extensive research and development facilities. BICC undertake the manufacture and installation of cables for every type of telecommunication system anywhere in the World.

*Technical information on BICC Telephone Cables is contained in our publications—freely available to Telephone Administrations.*

**BRITISH INSULATED CALLENDER'S CABLES LIMITED**

*International Sales Office:*

**21 BLOOMSBURY STREET LONDON WC1 ENGLAND**

*Branches and Agents throughout the world*

**QUAD TRUNK CABLE**

This cable, manufactured to a British Post Office specification is produced in large quantities for audio frequency junction circuits. In common with other types of cable, they can be made to comply with any national or private specification.



# CABLES

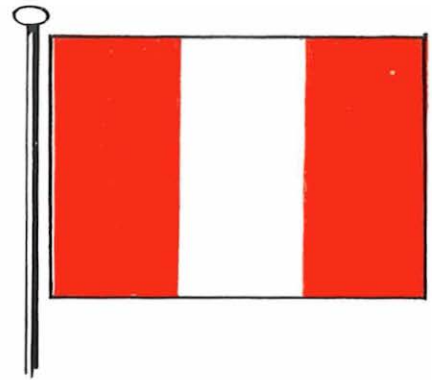

President Fernando Belaunde made the inaugural call over the U.H.F. microwave radio link between Lima and Arequipa on November 11th. This marked the completion of the first stage of the microwave network being supplied to the Compañía Nacional de Teléfonos del Perú by The General Electric Co.



# Peru Microwave Link Opens

## KEY

|   |                     |
|---|---------------------|
|  | TERMINAL            |
|  | MULTIPLEX EQUIPMENT |
|  | UNDER CONSTRUCTION  |
|  | OPERATING           |

For further information on the radio and multiplexing equipment, please write for standard specifications SPO5501 and SPO1370.

Ltd., of England. When completed, the network will be the longest in South America stretching 1100 miles along the Pacific seaboard. It will comprise altogether five terminal and twenty seven bothway repeater stations and links the towns of Arequipa, Lima, Trujillo, Chiclayo and Piura. The system uses G.E.C.'s U.H.F. radio equipment operating at 2000 Mc/s.

# Complete Service by *G.E.C.*

This network typifies the complete service that G.E.C. can provide in the supply of telecommunications equipment. G.E.C. engineers were responsible for surveying, planning, engineering, manufacturing, installing and commissioning the complete network. In addition, the Company undertook to train Peruvian engineers in the use and operation of the equipment. This training took place both in Peru and at G.E.C.'s Telephone Works in Coventry.

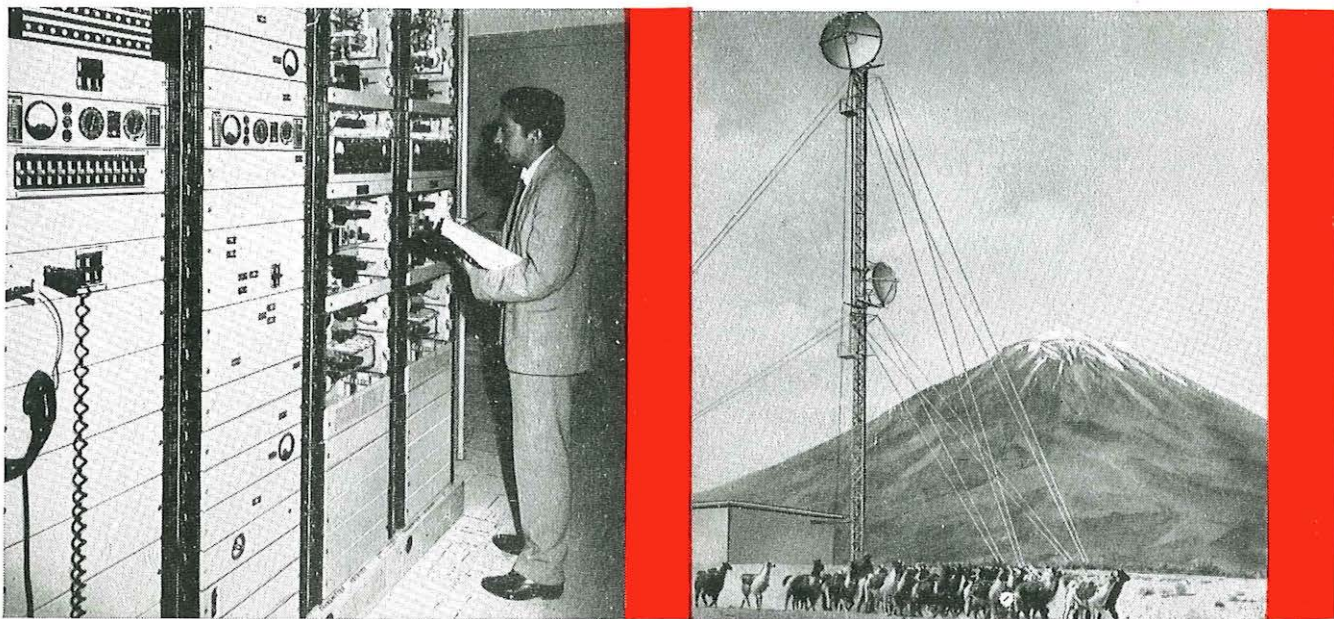

G.E.C. Radio Equipment Racks at Washington Terminal, Lima.

Aerial and Tower at Caima Repeater Station.

**G.E.C.**

**EVERYTHING FOR TELECOMMUNICATIONS**

Transmission Division

**G.E.C. (TELECOMMUNICATIONS) LTD.**

TELEPHONE WORKS · COVENTRY · ENGLAND

Works at Coventry · Middlesbrough · Treforest

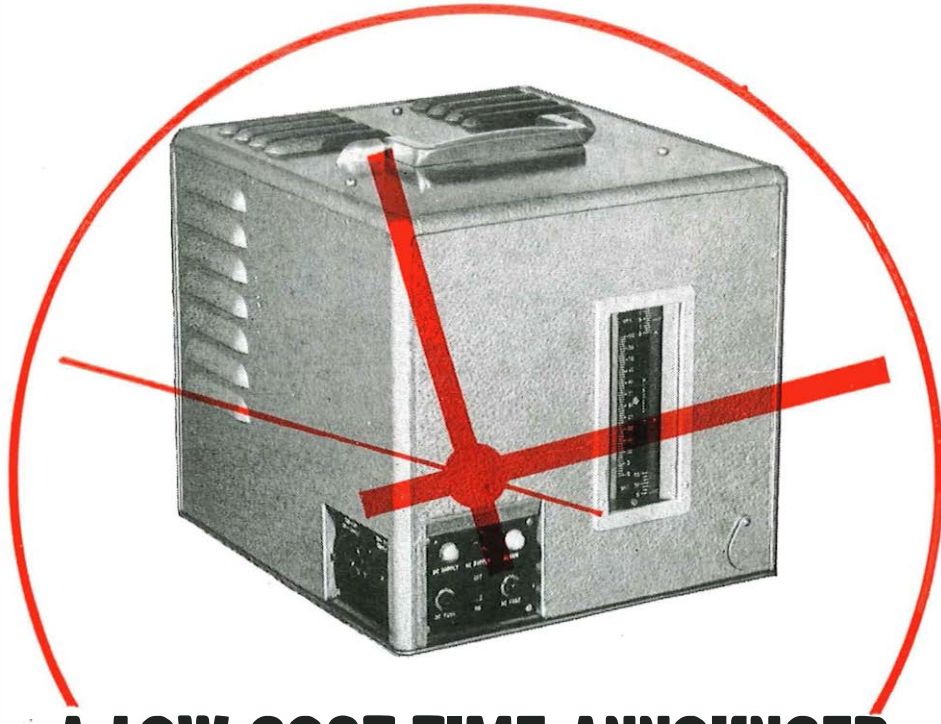

## A LOW COST TIME ANNOUNCER FOR TELEPHONE NETWORKS

Among telephone administrations contemplating a time announcing device there is a growing demand for a simple and low cost equipment not of "observatory" standards but accurate enough for all normal domestic and commercial purposes.

This new Time Announcer meets these requirements by dispensing with complex frequency correcting apparatus and relying on the mains frequency where "stable" or the exchange master clock.

Where a higher degree of accuracy is required an announcer can be provided which is driven from a crystal source.

Complete announcements are delivered every ten seconds and are accessible to subscribers either by dialling or by asking the operator for the Time Service.

The equipment which is free standing is compact ( $12\frac{1}{4}'' \times 12\frac{1}{2}'' \times 13\frac{3}{4}''$ : 31cm x 32cm x 35cm), robust and essentially simple requiring a minimum of skilled attention over long periods.

Recordings, which are made by our audio engineers, are normally transferred to the announcer from tapes supplied by the customer. Recording and head life expectancy is of the order of five years when re-recording and head replacement can be done as necessary.

If you would like a leaflet describing in detail this new low cost Time Announcer then please write to the address below:—



**ERICSSON TELEPHONES LIMITED  
ETELCO LIMITED**

Head Office: 22 LINCOLN'S INN FIELDS · LONDON WC2 · Telephone: HOLborn 6936

# SANDERS

## MICROWAVE POWER METER

A versatile instrument for power measurements from 1 micro-watt to 10 milli-watts. For use with bolometers and thermistors requiring 10 milli-amps bias or less to attain 200 ohms resistance. Provision is made for temperature compensation. When this facility is used with matched sensing elements, drift is limited to less than 5 micro-watts for 1°C change in ambient. Monitoring socket provides d.c. voltage proportional to microwave power. Fully transistorised to give low weight and low power consumption. Power can be taken from a.c. mains or internal batteries.

**Overall range:**  
1 micro-watt to 10 milli-watts

**Accuracy:**  
Within  $\pm 3\%$

**Dimensions:**  
11.3 ins. wide x 8.5 ins. high  
x 7.75 ins. deep.  
(28.7 cm. x 21.7 cm. x 19.6 cm.)



*Intelligent expansion has been the byword of the Sanders Group of Companies. The Group provides three main manufacturing facilities—Microwave, Industrial Electronics and Precision gears—each with its own factory, development laboratory, inspection department and production plant offering a wide range of sub-contract and calibration facilities.*

THE  
**Sanders**  
GROUP OF  
COMPANIES

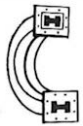

As leaders in the microwave field with many years experience of both rigid and flexible waveguide assemblies, Sanders have manufacturing facilities for the rapid production of precision microwave components.

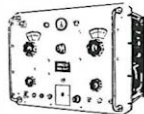

A wide range of proprietary and Service laboratory test equipment is manufactured. Sanders undertake original design and development work on behalf of Government and Industrial organisations.

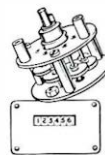

The design, development and production of precision gear chains, gear boxes, digitisers and resolvers are carried out rapidly and efficiently and a wide range is available from stock. All types of precision mechanical assemblies for servo systems can be provided.

For more detailed information please write to:

**W. H. SANDERS (ELECTRONICS) LIMITED.** Gunnels Wood Road · Stevenage · Herts · Telephone: Stevenage 981





# Caribbean Carrier

Forget the bananas and the sun-drenched sands; the coral seas and the wrecks of Spanish treasure-ships. Jamaica is now the commercial hub of the Caribbean world, and soon to be the vitally important transit centre for the Commonwealth-USA-South America communications network.

**In Readiness** for this tremendous development in telecommunications, the Jamaican Telephone Company have chosen ATE Type CM multiplex equipment for channelling on to the existing Kingston-Montego Bay link.

**Getting Away** altogether from conventional design, ATE have succeeded brilliantly in producing a compact, fully reliable carrier which is *only one-third the weight* of an equivalent valve equipment, *and saves up to 90% of the power normally used.*

**The Secret?** The card-mounted printed circuit of advanced design.

Jamaican Telephone is only one of the leading organizations throughout the world which have chosen ATE Type CM Carrier Equipment for microwave, open-wire and cable carrier communications.

Fully transistorized/Plug-in printed circuits/Mains or battery operation/Optional in-built out-band 3825 c/s low or high level signalling for ringdown or dialling/Suitable for extension to existing valve equipment/●one-third the size of an equivalent valve unit. **Automatic Telephone & Electric Co. Ltd. 8 Arundel St. London WC2 Tel: Temple Bar 9262**

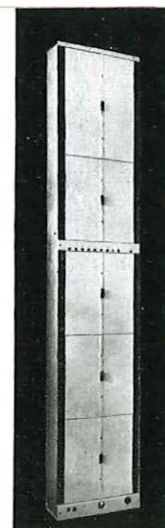
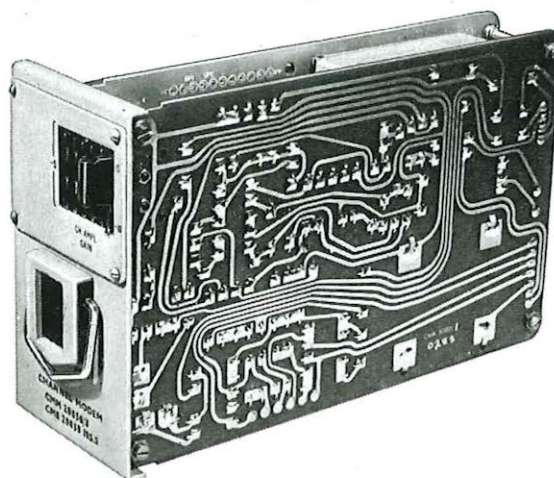

## INDEX TO ADVERTISERS

|  | PAGE   |   | PAGE      |
|--|--------|---|-----------|
| Adcola Products, Ltd. ... ..   | 31     | National Salt Glazed Pipe Manufacturers' Association    | 13        |
| Associated Electrical Industries, Ltd. ... ..                          | 26     | Oxley Developments Co., Ltd. ... ..                     | 9         |
| Associated Iliffe Press, Ltd. ... ..                                   | 9      | Pitman, Sir Isaac, & Sons, Ltd. ... ..                  | 10        |
| Automatic Telephone & Electric Co., Ltd. 20, 32-33, 44-45              |        | Pye Telecommunications, Ltd. ... ..                     | 48        |
| Avo, Ltd. ... ..   | 10     | Redifon, Ltd. ... ..                                    | 21        |
| British Institute of Engineering Technology ... ..                     | 10     | Rootes Tempair, Ltd. ... ..                             | 27        |
| British Insulated Callender's Cables, Ltd. ... ..                      | 38-39  | Sanders, W. H., (Electronics), Ltd. ... ..              | 34, 43    |
| British Resin Products, Ltd. ... ..                                    | 30     | Standard Telephones & Cables, Ltd. 7, 8, 11, 12, 14, 47 |           |
| Celcure, Ltd. ... ..   | 5      | Submarine Cables, Ltd. ... ..                           | 3         |
| Ericsson Telephones, Ltd. ... ..                                       | 35, 42 | Telegraph Condenser Co., Ltd. ... ..                    | 27        |
| G.E.C. (Telecommunications), Ltd.<br>4, 15-16, 19, 22-23, 28-29, 40-41 |        | Telephone Cables, Ltd. ... ..                           | 6         |
| Great Northern Telegraph Co., Ltd. ... ..                              | 9      | Telephone Manufacturing Co., Ltd. ... ..                | 2, 24, 36 |
| Marconi Co., Ltd., The ... ..  | 18     | Westinghouse Brake & Signal Co., Ltd. ... ..            | 17, 25    |
| Mullard, Ltd. ... ..   | 37     | Whiteley Electrical Radio Co., Ltd. ... ..              | 31        |
|  |        | Winn & Coales, Ltd. ... ..                              | 46        |

# DENSO PROTECTION

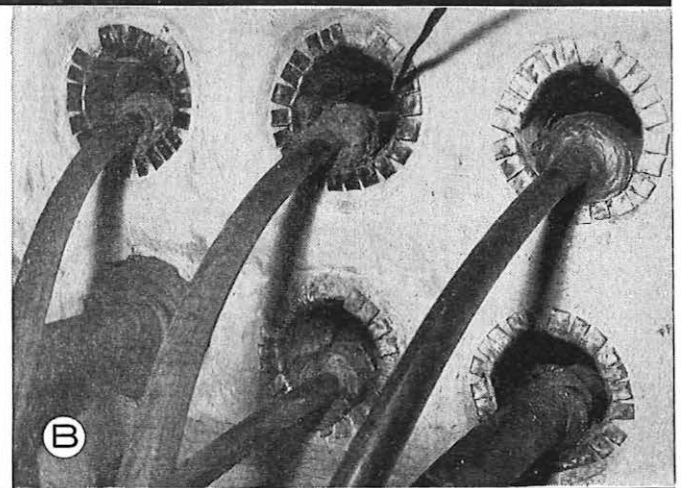
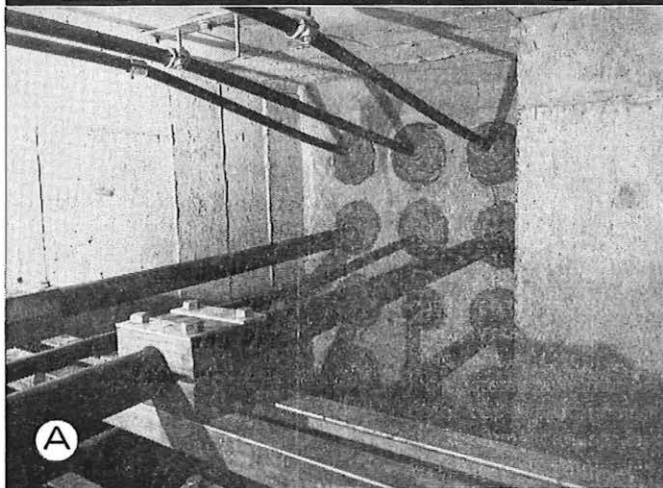

## FOR CABLES AND PIPES

- A** Inside an inspection chamber — the cables are supported by steelwork and the ends of the duct sealed with Denso Mastic. Denso Mastic is the all-purpose cold applied sealing medium, and can be used for plugging, sealing and caulking duties below ground, above ground or underwater.
- B** Underground cables in ducts. Denso Tape is used to protect the cables where they pass over lead linings at the edge of the pipe in case the cable sinks onto the hard edges.

*DENSO MASTIC and DENSO TAPE are used by the Central Electricity Generating Board, who also supplied the photographs.*

### WINN & COALES LTD

Denso House, Chapel Road, London, S.E.27.  
Tel: GIPsy Hill 7511  
*Also at Manchester, Belfast and Dublin.*  
*Agents throughout the Commonwealth.*

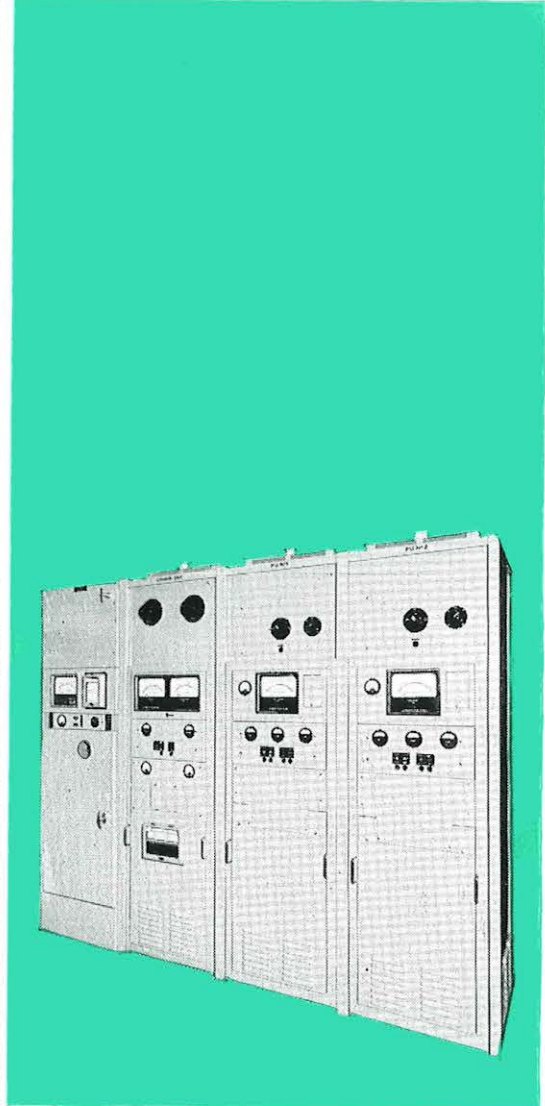

**POWER FEEDING FOR SUBMERGED REPEATERS** Submarine repeaters for submarine cable telephone systems are specially designed and manufactured to give long life and high reliability, but the maintenance of these qualities in service depends largely on the performance of the shore-based power feeding equipment. STC has developed a new Transductor Controlled Power Feeding Equipment—now in operation with NATO and ordered by the British G.P.O. for systems to operate across the North Sea—which has the following features: Up to 3 power units can operate in parallel, leading to simplification of switching circuits. Single-end or double-end feeding can be employed using the STC master/slave scheme. Transductor control has eliminated thermionic devices from the control circuits, thereby increasing reliability and reducing maintenance. Operation from a 400 c/s supply gives faster response times, and the size and number of components are reduced compared with equipments working from a 50 or 60 c/s supply. 5 kV, 7½ kV and 15 kV versions can be supplied. Write, 'phone or Telex for leaflet C/AE39: Standard Telephones and Cables Limited, Transmission Systems Group, North Woolwich, London, E.16. Telephone ALBERT Dock 1401. Telex 21645.

world-wide telecommunications and electronics

**STC**

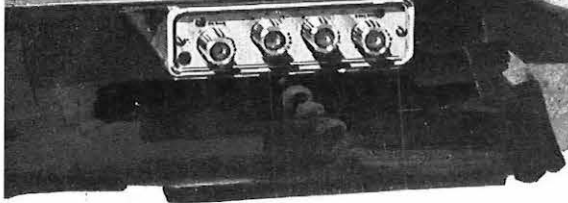

These Advanced Features give the Vanguard **EXTRA PERFORMANCE**  
UNIT PRINTED BOARD CIRCUIT ELEMENTS

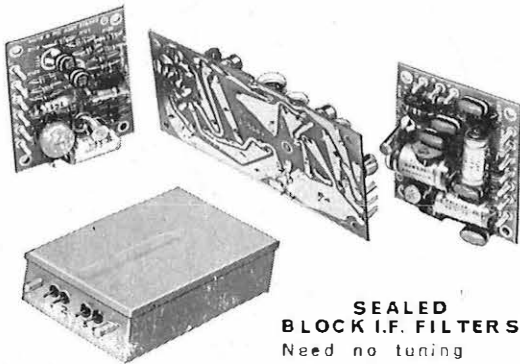

SEALED  
BLOCK I.F. FILTERS  
Need no tuning



INTRODUCE THE  
**VANGUARD**  
A Magnificent

25-Watt Transistorised  
**RADIOTELEPHONE**

**ONLY** the VANGUARD has ALL these qualities

- 25/30 & 50/60Kc/s channels
- Extensively Transistorised
- Sealed Block I.F. Filters
- Printed Circuitry
- Very low Battery Drain
- All Aluminium Construction
- Dust-proof and splash-proof
- One—Six Channels
- 25 Watts Output
- Very low-noise Receiver
- High Stability Mute
- 4 Watts Audio Output

Meets British, American, Canadian and Continental Specifications

**PYE TELECOMMUNICATIONS LIMITED . . . CAMBRIDGE**

