

# THE POST OFFICE ELECTRICAL ENGINEERS' JOURNAL



Vol. 55 Part 1

APRIL 1962

## CONTENTS

	Page
THE FARADAY LECTURE, 1961-62.....	1
A WATERPROOF LOUDSPEAKING TELEPHONE—LOUDSPEAKING-TELEPHONE NO. 3 W. T. Lowe, A.M.I.E.E.....	6
A CABLE-FAULT LOCATOR FOR SUBMARINE CABLES G. J. Crank, B.Sc.(Eng.), A.M.I.E.E., and H. A. Hathaway.....	8
A SPEECH COMPANDOR USING JUNCTION TRANSISTORS D. Thomson, A.M.I.E.E.....	14
AN AUDIO-FREQUENCY TRANSMISSION MEASURING SET USING TRANSISTORS K. W. Lee, B.Sc., A.M.I.E.E., and K. S. Ratcliffe.....	19
INTEGRATION OF THE INTERNATIONAL AND CONTINENTAL TELEPHONE SERVICES C. J. Maurer, C.G.I.A., B.Sc.(Eng.), A.M.I.E.E., and E. Newell, B.Sc.(Eng.), A.M.I.E.E.....	22
A MINIATURE LEVER KEY OF IMPROVED DESIGN K. H. Clarkstone.....	29
THE JOINT USE OF POLES FOR TELECOMMUNICATION AND POWER LINES S. J. Little, M.I.E.E.....	31
PROGRESS IN THE PROVISION OF SUBSCRIBER TRUNK DIALLING.....	36
SCOTICE—THE UNITED KINGDOM TO ICELAND CABLE SYSTEM.....	38
COOLING SYSTEM FOR HIGH-POWER RADIO TRANSMITTERS A. E. N. Wase, A.M.I.E.E.....	40
THE USE OF HAMMER FINISH ON APPARATUS.....	43
COAXIAL LINE EQUIPMENT FOR SMALL-DIAMETER CABLES J. C. Endersby and J. Sixsmith.....	44
POWER UNITS FOR USE AT SUBSCRIBERS' PREMISES M. B. Moore, A.M.I.E.E.....	49
SIGNALLING SYSTEM A.C. NO. 9 J. V. Miles and D. Kelson, A.M.I.E.E.....	51
NOTES AND COMMENTS.....	59
INSTITUTION OF POST OFFICE ELECTRICAL ENGINEERS.....	62
REGIONAL NOTES.....	63
ASSOCIATE SECTION NOTES.....	65
STAFF CHANGES.....	68
PAPERS AND ARTICLES ON TELECOMMUNICATIONS AND OTHER SCIENTIFIC SUBJECTS	71
BOOK REVIEWS.....	7, 18, 21, 28, 39, 42, 48, 62, 67

Price 2s. 6d. (Post Paid 3s. 6d.)

Published in April, July, October and January by *The Post Office Electrical Engineers' Journal*,  
G.P.O., 2-12 Gresham Street, London, E.C.2.

Annual Subscription (post paid): Home and Overseas, 14s. (Canada and U.S.A., 2 dollars 25 cents).

# THE POST OFFICE ELECTRICAL ENGINEERS' JOURNAL

Vol. 55 Part 1

APRIL 1962

## The Faraday Lecture, 1961-62

U.D.C. 621.39

THE thirty-third Faraday Lecture, entitled "Expanding Horizons in Communications," was presented by Mr. D. A. Barron, C.B.E., M.Sc., M.I.E.E., Deputy Engineer-in-Chief of the Post Office Engineering Department, at 12 centres in Great Britain and Northern Ireland during the winter months of 1961-62. Arranged by the Institution of Electrical Engineers, these lecture tours are held annually in memory of Michael Faraday (1791-1867), as a tribute to his distinguished pioneering work in electrical science. The primary purpose of the Faraday Lecture is to increase the interest of the general public in electrical matters, particularly those having a bearing on the life of the community. There is little doubt that no other branch of the electrical industry has a greater claim in this field than communications, and Mr. Barron, therefore, gladly accepted the Institution's invitation to present the 1961-62 Lecture. The last occasion that the Post Office was honoured by being asked to be responsible for the Lecture was in 1938-39, and though the changes that have occurred in the communications field in the intervening years have been quite remarkable, even greater developments are predictable in the next few years.

In preparing his talk, Mr. Barron, with his long experience in telecommunications, must certainly have found it difficult to decide what to exclude, particularly in view of the very wide scope of Post Office activities. However, there is no doubt that he made the right selection, and the lecture formed a most comprehensive survey of an extensive range of topics, many of them technically complex, and it was couched in terms that could be readily appreciated by members of the general public and yet be of interest to the more technically minded. This, coupled with Mr. Barron's informal and entertaining style of delivery (Fig. 1 shows him explaining a point with characteristic emphasis), resulted in a very popular lecture indeed—as the enthusiastic applause during, and at the end of, each presentation amply testified.

For his subject, Mr. Barron chose the fascinating story of the developments that have already taken place, and those expected within the next decade or so, to meet the continuing challenge presented by the rapid world-wide growth in the demand for communications. In particular, Mr. Barron's lecture dealt with three aspects that have a profound effect upon the provision of communications, namely, distance, signalling speed and circuit utilization. These aspects are the constant concern of telecommunications engineers in the Post Office and in industry because, speaking metaphorically, the horizon of each

of them is expanding so rapidly.

The 12 centres at which the lecture was given were: Bristol, Birmingham, Nottingham, Sheffield, Southampton, Newcastle, Liverpool, Glasgow, Cardiff, Stoke-on-Trent, London, and Belfast.

At the first seven of these centres, by arrangement between the Institution of Electrical Engineers and the local education authorities, Mr. Barron gave an additional presentation of the lecture to senior students from colleges and schools in the neighbourhood. Many of the students travelled by coach as far as 50 miles or



*Photo by courtesy of the Sheffield Telegraph and Star, Ltd.*

FIG. 1—MR. BARRON EMPHASIZES A POINT AT SHEFFIELD



FIG. 2—VIEW OF THE STAGE AT THE PHILHARMONIC HALL, LIVERPOOL

more from their schools to the hall and it is particularly interesting to record that at Southampton a boat was specially chartered from British Railways to bring nearly 300 students from the Isle of Wight. Several of these centres organized students' essay competitions based on this year's lecture. These competitions have been so successful that they may become a regular feature of future Faraday Lectures.

Attendances were extremely good at every centre for both the adult and the student presentations, and altogether some 40,000 people heard the lecture, of whom the vast majority were members of the general public—proving that the original purpose of the Faraday Lectures had been successfully achieved once again.

In addition, a B.B.C. film unit from Manchester visited Newcastle to record on sound and film several of the demonstrations and an interview with Mr. Barron. This was subsequently shown to northern viewers in the B.B.C. "Points North" program. The lecture was also featured in the local television news from the Newcastle and Belfast stations and a recorded interview with Mr. Barron was broadcast from Cardiff.

It is traditional for the lecturer to illustrate his talk with working models, slides, film, etc., and in past lectures a high standard has regularly been achieved. The design of Mr. Barron's models and displays had obviously received his very careful consideration during the preparatory stages. Both the Press and many individuals have, in fact, expressed the view that the demonstrations were the best and most spectacular ever seen in a Faraday Lecture. The complete stage layout can be seen in Fig. 2 which shows the equipment as arranged for the lecture at the Philharmonic Hall, Liverpool.

Mr. Barron began with a brief review and demonstration of the principles involved in interconnecting two subscribers on the same exchange by manual and by automatic methods. For this demonstration there was a model manual-exchange position and giant working models of a dial and a two-motion selector (Fig. 3). These models were beautifully made and worked with precision—features, in fact, that were common to all the models used throughout the lecture—and the dial and selector never failed to win the especial appreciation of the audience. To bring matters back into the correct perspective, this short section of the lecture ended with a working demonstration of a real telephone and final selector.

Having ensured that the audience appreciated the principles, Mr. Barron then proceeded to show how local automatic telephone networks can be progressively extended into a system wherein any subscriber can dial any other in the world. In this country, subscriber trunk dialling (S.T.D.) has steadily extended since 1958, and towards the end of 1962, London subscribers with national trunk-dialling facilities will be able to dial directly to Paris. In 1964, these London subscribers will be able to dial directly to other European countries, and subscribers in those countries will be able to dial London calls. For other subscribers in the United Kingdom, provision of these facilities will follow as quickly as the necessary arrangements can be made. The build-up of national numbering schemes for subscriber trunk-dialling purposes, both inland and international, was next explained and demonstrated by means of three illuminated panels each 10 ft wide by 5 ft high.

During the complete lecture, eight of these panels

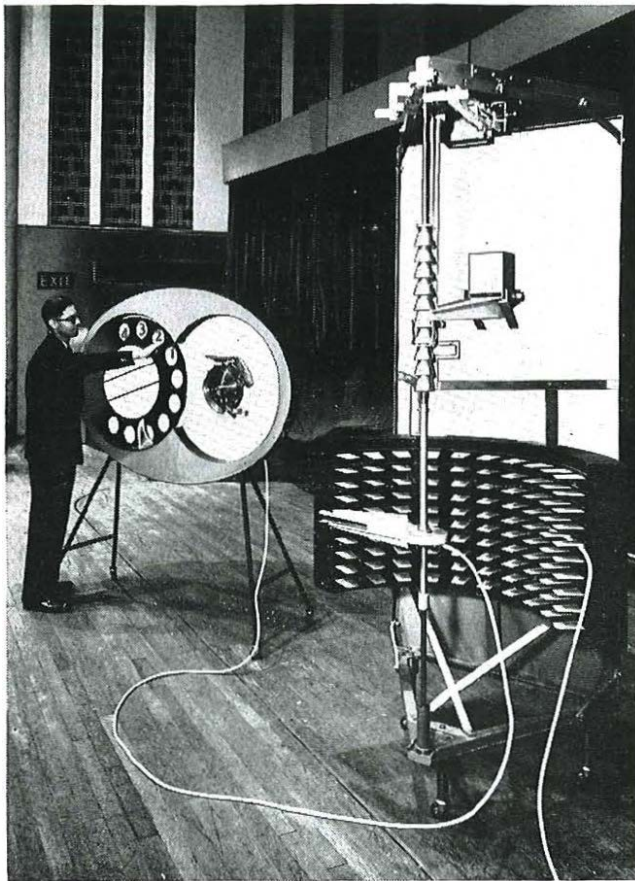

FIG. 3—THE DIAL AND THE TWO-MOTION SELECTOR

were shown. All eight were contained in an ingenious magazine which was completely hidden from the audience. Each time the curtains parted, a new panel had moved silently into position and as Mr. Barron mentioned particular features, coloured lights flashed or sounds emerged by way of illustration, with split-second timing. Fig. 4 shows the panel illustrating international dialling about to be demonstrated.

The method of displaying these panels presented a major problem. Owing to their size and weight—some

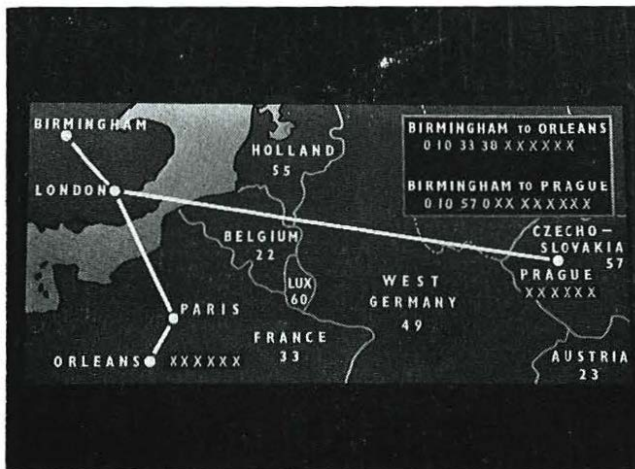

FIG. 4—A PANEL ABOUT TO BE DEMONSTRATED

of them weighed nearly 2 cwt—the panels could not easily be moved on stage during the lecture and it was very desirable that they should be displayed in sequence in one central position. After several ideas had been tried and discarded, a successful “magazine” was devised consisting of a four-sided revolving framework, each side supporting two panels fixed back-to-back and pivoted at the centre so that each pair could be reversed without moving the main framework. Thus, by pairing panel No. 1 with panel No. 5, panel No. 2 with panel No. 6, panel No. 3 with panel No. 7, and panel No. 4 with panel No. 8, it was possible to display the eight panels in correct sequence in eight 90° turns of the framework, each pair being reversed at the rear position of the framework after one side had been displayed. Completely assembled, with the panels in position, the magazine weighed about 1 ton.

The animation of the lighting of the panels was controlled by keys on a console which also housed the relays and switches. Plug-ended flexible leads connected the console with the panels. These leads and the general form of construction of the magazine can be seen in Fig. 5.

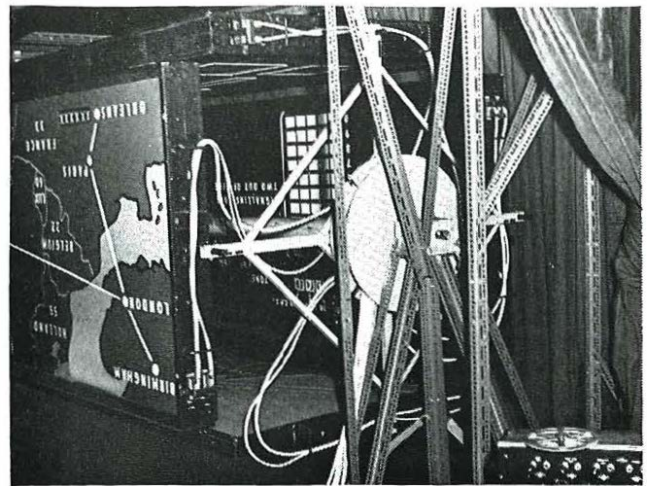

FIG. 5—A REAR VIEW OF THE PANEL MAGAZINE

The precision mentioned in connexion with the operation of the panels was typical of all the displays and demonstrations; in fact, to quote the comment of one member of an audience, “the staging throughout the lecture was a sheer delight to watch.” Fig. 6, taken “backstage”, shows the demonstration team in action.

Mr. Barron next described the functions of the register-translator which is one of the basic features of a subscriber trunk dialling system. Another panel was used at this stage of the lecture to help the audience to understand the essential functions of this “automatic operator.”

Methods whereby switching instructions are signalled from point to point as a call is set up, were next discussed and illustrated with two more panels. The first showed clearly the principle of two-out-of-five tone signalling and the second most strikingly indicated how fast this method is compared with pulse signalling. This latter panel was so popular that Mr. Barron invariably had to call for it to be operated again.

Mr. Barron then went on to describe the essential difference between exchanging information by telephone



FIG. 6—"BACKSTAGE" DURING A LECTURE

and by telegraph, and this led to a review of the inland and international automatic telex facilities available in the United Kingdom. Telex, as he pointed out, is increasingly in demand and is particularly useful to business organizations. As an illustration of modern telex facilities, messages were sent to and fro between two teleprinters situated at opposite sides of the stage. The signals sent to line during the operation of the teleprinters were amplified and broadcast so as to give a realistic sound accompaniment to a close-up film of a teleprinter type-head printing the message which the operator was sending. At each centre where the lecture was given, local Post Office teleprinter operators assisted Mr. Barron with this part of his demonstration, and the audience readily joined him in thanking these young ladies for their efficient performance.

The operation of a teleprinter printing on paper tape was next shown on film, and finally in this section of the talk the audience saw a slide of a Greetings telegram bearing the tape message previously seen on the film.

The growth of the extensive local and trunk cable networks in this country, and developments in cable design, were the subject of the next part of the lecture. The need for amplifiers on the longer circuits and the enormous improvements in their circuit-handling capacity were also explained, and this was followed by an introduction to carrier working. From this introduction Mr. Barron proceeded to show how carrier working has been progressively extended, first by the use of larger carrier cables and, later, by the use of coaxial cables and radio systems, so as to provide the enormous numbers of trunk circuits that are necessary to meet the ever-growing demands of traffic. This part of the lecture was illustrated by appropriate samples of cable, and with films and slides in colour.

To indicate to the audience how economically line plant is used, the lecturer returned for a few moments to the subject of telegraphs for a description of multi-channel v.f. telegraphy. This explanation and the accompanying panel showed clearly how 24 telegraph circuits are worked over a single speech circuit.

Line-of-sight microwave radio systems were next explained and illustrated by the last of the eight panels. Such systems are an alternative to coaxial cable systems for national links of high circuit capacity and both may carry television programs, trunk telephone circuits, or a

proportion of each. Appropriately at this stage Mr. Barron introduced the subject of waveguides as a development of microwave radio practice, and this was illustrated by a stage demonstration that received enthusiastic applause. A length of waveguide some 20 ft long had been set up on the stage complete with transmitter and receiver. Using a carrier of 35,000 Mc/s, music was transmitted over the guide and when a removable centre station of the guide was slowly lifted out the music died away. Fig. 7 shows Mr. Barron's assistant holding the centre section. Also, to show the audience that the demonstration was quite genuine, a sheet of copper was inserted slowly into the guide at one end of the removable section; this gave the same effect as lifting out the centre section. The enormous circuit capacity of waveguide systems, and hence the tremendous promise that they hold for trunk communications on routes where very large numbers of circuits are required, was emphasized, although, as Mr. Barron pointed out, there are many technical problems to be solved before such systems can be worked over long distances. Nevertheless, he predicted that such systems may well be in operation within the next 10 years.

Turning to intercontinental communications, Mr. Barron next described how the earlier long-distance submarine cables, which could only carry a single telegraph circuit, are, together with long-distance long-wave radio systems, being supplanted by modern coaxial submarine telephone cables with their highly reliable under-water repeaters. These provide links that will carry some dozens of high-quality telephone circuits whose performance is consistently good, unlike those on long-distance radio systems which are sometimes adversely affected by atmospheric conditions. Here again, cable samples, film and slides in colour, and the internal unit of an actual submarine repeater, helped to convey to the audience a clear picture of this fascinating part of the story of the development of world-wide communications.

The film included sequences showing the manufacture of a submarine repeater and then H.M.T.S. *Monarch* loading and laying submarine cable and repeaters. The film concluded with scenes of the *Monarch* laying the TAT-1 cable in rough weather in 1956.

But the demand for intercontinental circuits, as for

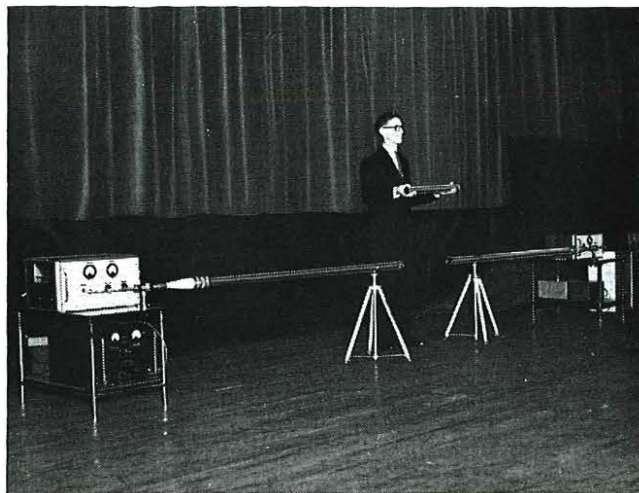

FIG. 7—DEMONSTRATION OF THE WAVEGUIDE

inland circuits, is unrelenting. There are limits to the extent to which the bandwidth—and hence the circuit capacity—of submarine telephone cables can be increased, and engineers have given special attention to using the available circuit capacity to maximum efficiency. This has led to the development of the ingenious time assignment speech interpolation system (T.A.S.I.) whereby most of the unused circuit time that occurs during a normal telephone conversation is utilized by connecting a speaker to a channel only when he is actually talking. This enables the circuit capacity of a cable to be approximately doubled at far less cost than laying a second cable and this, as Mr. Barron said, is a tremendous and most valuable gain. The equipment that does this job is undoubtedly complex but Mr. Barron's explanation of its operation was certainly easy enough to follow. To help the explanation along there was another fine working model that showed bursts of speech from several conversations being rapidly switched to follow one another across the Atlantic in both directions of transmission so as to give full occupancy of channels. The model can be seen in Fig. 8 which shows the start of the conversations from London to New York.

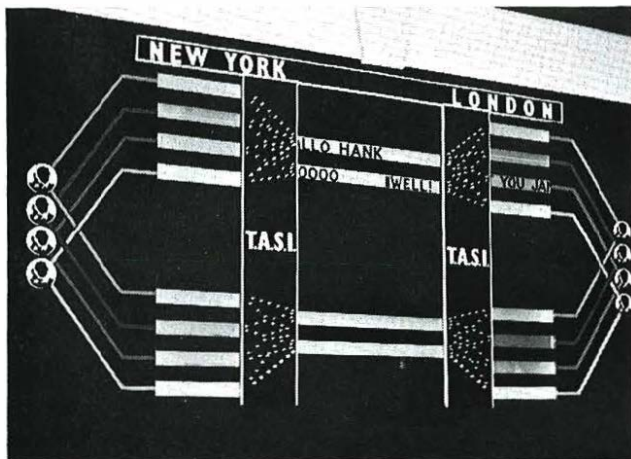

FIG. 8—THE T.A.S.I. DEMONSTRATION MODEL

A laboratory-made tape recording indicating the mixed-up speech bursts one would hear if one could listen on a transatlantic channel was next played over to the audience. There had been no attempt to create humour when the tape was made but the snippets of conversation and their random relation to one another proved to be "a winner" with every audience.

Earlier in the lecture it was explained that line-of-sight microwave radio systems required intermediate relay stations at approximately 30-mile intervals and would, therefore, be quite impracticable to span large oceans. Mr. Barron returned to this point to show how the situation altered with the advent of space satellites which could orbit at great distances above the Earth's surface. The lecture concluded with a survey of this remarkable advance in communication engineering.

Two types of satellite—the purely reflective type and the active, or repeated, type—were first described. The former would, however, require enormous power at the transmitting ground station and for this and other technical reasons, this type seems unlikely at present to be developed for commercial communications. On the

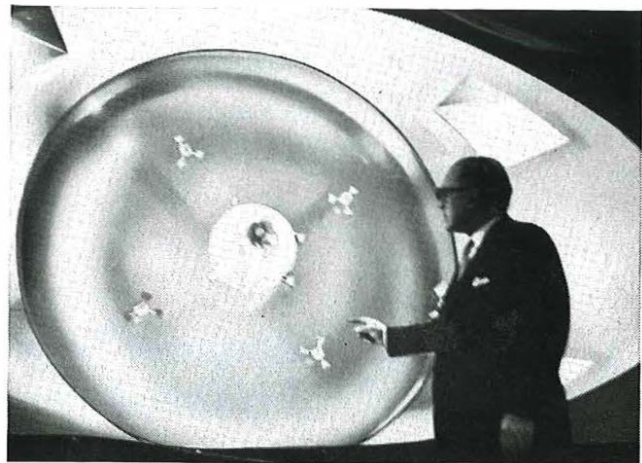

Photo by courtesy of the Sheffield Telegraph and Star, Ltd.

FIG. 9—MR. BARRON EXPLAINS THE SATELLITE MODEL

other hand, the active-type satellite requires a source of power for the amplifying equipment and Mr. Barron explained in detail how this power may be derived from sunlight by means of solar cells. Using a torch and a tiny unit containing silicon cells, a transistor oscillator and an earpiece, he demonstrated how a solar cell functions. When the light from the torch was directed on to the cells sufficient power was generated to energize the oscillator, and by holding the earpiece to a microphone the resulting audio frequency was broadcast over the public address system thus effectively demonstrating a double conversion process—from light energy to electrical energy and then to sound energy.

The various kinds of orbit which might be used for active satellites, and the requirements of the associated ground-aerial stations were next surveyed and the whole technique was then magnificently displayed by means of a large and extremely imaginative model. On this were seen one "stationary" and four moving satellites in circular orbit around a revolving Earth. Illuminated only by ultra-violet light, the model gave a most realistic space effect, the satellites appearing to move in their orbits entirely unsupported. To add further realism, a beam of light was transmitted from a fixed transmitter on the Earth via the "stationary" satellite to a fixed receiver further round the Earth's surface. This light beam controlled a music amplifier and when the beam was interrupted the music automatically stopped. Fig. 9 shows Mr. Barron explaining a feature on the model; the mechanism at the rear of the model and the operating team may be seen in the background of Fig. 6.

Mr. Barron made the point that there are many technical problems to be solved before such systems become suitable for commercial use, but that solutions would no doubt be found and the prospect of world-wide relay systems having vast telephony and television circuit capacity may well become reality in the relatively near future. The British Post Office for its part is participating soon, with American and continental engineers, in trials with satellites which will, initially, be American. For these trials a tracking and communications ground station is being built at Goonhilly Down, near the Lizard in Cornwall. The main steerable aerial, which weighs some 870 tons, is already nearing completion.

Mr. Barron when replying to the enthusiastic votes of

thanks which followed the lectures, always made the point that the progress he had described rested on the excellent and co-operative work of research and development staffs, not only in the Post Office but in the telecommunications industry of the United Kingdom. He also paid generous tribute to the assistance given him

by many Post Office colleagues, both at headquarters and in the Areas, in the design, construction, transportation and erection, as well as in the operation and demonstration, of the many exhibits and working models which had contributed so much to the value of the lecture.

C.J.S.

## A Waterproof Loudspeaking Telephone— Loudspeaking-Telephone No. 3

W. T. LOWE, A.M.I.E.E.†

U.D.C. 621.395.623.7—76

A hermetically-sealed loudspeaking telephone has been developed for use in situations where complete washing of the instrument is necessary to prevent the spread of infection.

THE handset and dial of a normal telephone cannot be washed or sprayed without causing damage to the instrument. For installation in such places as hospital operating theatres, laboratories and mortuaries, where frequent spraying with disinfectant is necessary to prevent the spread of infection, a sealed loudspeaking telephone has been developed, in which the components are mounted in waterproof containers.

Although intended primarily for hospitals, the equipment may also be used in situations exposed to the weather or in laboratories at atomic research stations, which may be exposed to harmful radiations.

### DESCRIPTION

The complete equipment, which is known as a Loudspeaking-Telephone No. 3, comprises three units—a control unit (Control Unit No. 10A), a loudspeaker unit (Loudspeaker No. 5A), and an amplifier (Amplifier No. 138A). The control unit is usually mounted on a wall, at about head height, with the loudspeaker 3 ft or so above it, while the amplifier unit is placed in any convenient position in the same or in an adjacent room. The amplifier unit is not waterproof and if, therefore, it is placed in the same room as the control unit and loudspeaker it must be mounted inside a special waterproof container (Case No. 111A).

The equipment is not voice-switched and functions generally in the same manner as the Loudspeaking Telephone No. 1.\* A handset is not provided because of the difficulty in making it waterproof, and for the same reason there is no dial. If used in association with a direct exchange line to an automatic exchange, the loudspeaking telephone will be connected as an extension on an Extension Plan No. 7 or similar installation, so that all outgoing calls are dialled from the main instrument before being extended to the loudspeaking telephone.

### Control Unit

The control unit (Fig. 1) contains a microphone, push-button keys and an indicator lamp. The microphone is mounted behind a perforated grille, the apertures of which are sealed with a thin plastic membrane. Each push-button is mounted inside a flexible rubber

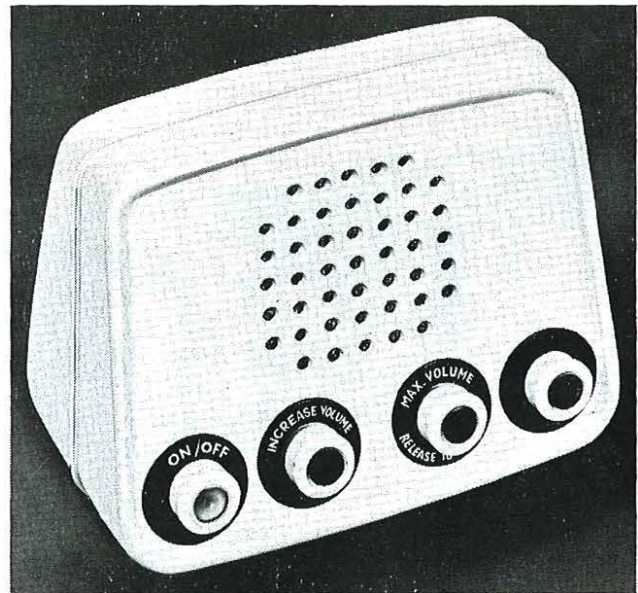

FIG. 1—CONTROL UNIT

bellows sealed to the case. The functions of the keys are as follows:

**On/Off Key.** When depressed, the ON/OFF key locks in the ON position, connects the equipment to the line, and gives a calling loop to the distant exchange or main telephone. A small indicator lamp, mounted inside the operating plunger of this key, glows while the call is in progress. A second depression unlocks the key and disconnects the equipment from the line.

**Volume Control 1.** This is a 2-position key giving low or medium volume of received speech from the loudspeaker. The mechanical action of this key is similar to that of the ON/OFF key.

**Volume Control 2.** This is a non-locking push key which, when depressed, gives maximum loudspeaker volume. Simultaneously, it switches the microphone out

†Mr. Lowe is in the Telephone Electronic Exchange Systems Development Branch, E.-in-C.'s Office, but was in the Subscribers' Apparatus and Miscellaneous Services Branch when this article was written.

\* LOWE, W. T., and WILSON, F. A. A Loudspeaking Telephone without Voice Switching—Loudspeaking-Telephone No. 1. *P.O.E.E.J.*, Vol. 54, p. 1, Apr. 1961.



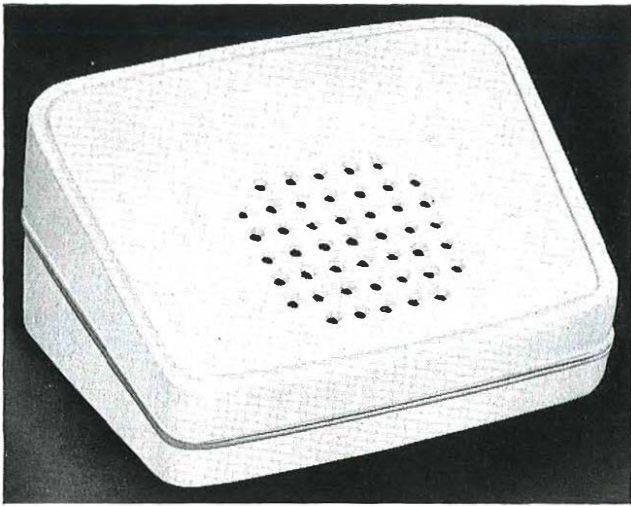

FIG. 2—LOUDSPEAKER UNIT

of circuit, thus preventing the onset of howling, which would otherwise occur with this maximum-volume condition due to the acoustic coupling between loudspeaker and microphone. The button must be released before speaking. Its use should seldom be necessary, but it is provided to compensate for the absence of a telephone handset, which would otherwise be used to receive faint calls.

A spare button is available for use if an additional signalling facility is required, such as "call main" on extension plan installations or "recall" on a P.B.X.

The case of the control unit is made in two similar halves, sealed by a neoprene gasket, of circular cross-section, which is fixed in a groove in the rim of one half of the case. Effective sealing is obtained because the

gasket, which protrudes slightly, is compressed by the flat rim of the other half of the case when the two clamping screws in the rear of the case are tightened. The instrument cord is sealed to the case by a special grommet.

If the control unit is to be mounted on a wall, a plate (Plate, Mounting, No. 3A) is first fixed to the wall in the required position. The plate has three keyhole slots in which three pins in the back of the control unit engage and lock; the control unit then simply drops into position.

#### Loudspeaker Unit

The loudspeaker unit (Fig. 2) contains a 3 in. diameter loudspeaker and a calling buzzer. The construction of the case, sealing of the apertures and the method of wall mounting are all similar to those of the control unit.

#### Amplifier Unit

The amplifier unit is the standard Amplifier No. 138A used for the Loudspeaking Telephone No. 1.

#### CONCLUSION

The first use of this waterproof loudspeaking telephone will be in hospitals where "hands-free" operation is required and extra cleansing precautions are taken. Its special features make it suitable for many other applications in providing telephone communication where hitherto it has not been practicable to install a standard telephone instrument.

#### ACKNOWLEDGEMENTS

Acknowledgements are due to the Telephone Manufacturing Co., Ltd., for their close co-operation in the design and production of this equipment.

## Book Review

"Transmission of Information." R. M. Fano. John Wiley & Sons. viii + 389 pp. 48 ill. 60s.

The transmission of information is the central purpose of virtually all telecommunications systems; yet the theory of the subject, involving quantitative treatment of the "information content" of signals and the capacity of transmission links for conveying information, has a reputation for abstractness which does not attach to other subjects of comparable theoretical difficulty, such as network analysis. The reason seems to be that the relationship between information, or communication, theory and the corresponding hardware is altogether less tangible. The subject is rooted in probability theory; direct measurements or demonstrations are hardly possible. The "information content" of a signal is high if the signal is very improbable and it depends, too, on all the signals (i.e. the "ensemble") that *might* have been sent. The merit of this book lies in the extreme lucidity with which it tackles difficulties, such as the concept of channel capacity, in reaching the stage where the practical usefulness of the subject becomes apparent. The book is firmly for graduate communications engineers and is, in fact, evolved from lectures given by the author at Massachusetts Institute of Technology. The fact that it stems from lecture notes seems to account for the vitality of

the text as well as for some of its faults, e.g. relatively poor cross-referencing. The discussion is rather strongly concentrated in terms of discrete or digital, as distinct from continuous or analogue, messages and channels. "Continuous" channels can be characterized mainly by "bandwidth" and "signal/noise ratio" and the author's treatment of them tends to be relatively dry and formal; he probably feels it is almost too well known that they possess meaningful "channel capacities" and is aware of the pitfalls that readily follow. However, a more helpful discussion of "continuous" concepts would be valuable.

A few failings should be mentioned. The index is thin and uneven. There seem to be an unusual number of errors, mostly of an editorial nature, in the text. It is difficult to find where some symbols (and, indeed, some specialized terms) first occur and they are nowhere listed. There are sample problems for each chapter but only an occasional hint on their solution. But these seem trivial faults beside the solid worth of the book as an exposition of the subject.

A final comment: the reader would find it a rewarding exercise to read two early papers (Shannon: *Bell System Technical Journal* (1948); Gabor: *The Journal of the Institution of Electrical Engineers*, Part III, Nov. 1946) on the same subject and to compare and contrast their contents with that of this book as he goes along.

J. S.

# A Cable-Fault Locator for Submarine Cables

G. J. CRANK, B.Sc.(Eng.), A.M.I.E.E., and H. A. HATHAWAY†

U.D.C. 621.317.333.4:621.315.28

D.C. tests to locate faults in submarine cables do not always yield reliable results, and skill and experience are necessary to obtain accurate locations. A portable tester employing the impedance/frequency method of fault location has therefore been developed, and this tester enables rapid and accurate results to be obtained in a simple manner.

## INTRODUCTION

**D**URING the course of a submarine-cable repair it is frequently necessary for fault-location tests to be made from the cable ship, and it is clearly important that rapid and reliable results should be obtained. The smaller cable ships are normally provided only with d.c. equipment for such tests, and under certain fault conditions results can be both difficult to obtain and unreliable. For this reason the fault locator\* described in this article was developed.

In deciding the form of the fault locator the following were considered to be the basic requirements:

(a) The equipment should be suitable for operation on all types of cable.

(b) The range of location should be at least  $\frac{1}{4}$ -20 nautical miles.

(c) The instrument should be quick and simple to operate.

(d) Specialized knowledge or skills should not be required in using the equipment.

(e) Reliability should be of a high order; periodic alignment or maintenance should not be necessary.

(f) The equipment should be compact and readily portable to allow occasional operation from a small boat or remote shore station.

(g) The instrument should be suitable for operation from a.c. mains or from a battery.

Broadly speaking, there are three basic types of fault-location tests available: d.c. tests, pulse tests and impedance/frequency tests. The impedance/frequency method of testing was chosen for the purpose in hand, the major disadvantages of the other two methods being as follows:

**D.C. Tests.** D.C. tests are often complicated by earth-current interference that can, when severe, render fault location impossible. The variable nature of the fault resistance under different test conditions has a profound effect on the accuracy with which the location can be made and also on the time taken to perform the tests. The majority of d.c. tests require a skilled and experienced operator to obtain an accurate location.

**Pulse Tests.** The very high attenuations of some of the old gutta-percha telegraph cables make them unsuitable for the satisfactory application of pulse techniques because of the restricted bandwidth that can be used. Also, in view of the complexity of pulse equipment, it would be very difficult to design, in a reasonably portable

form, an instrument to meet the requirements (a)-(g) previously mentioned.

As the equipment normally associated with impedance/frequency tests is basically simple, and since the method is readily adapted to cover wide ranges of location or different cable types simply by the correct choice of frequency range, the equipment described has been designed to employ this method of fault location.

## IMPEDANCE/FREQUENCY METHOD OF FAULT LOCATION

The impedance/frequency method of fault location is based on the modification of the sending-end impedance of a cable that occurs due to reflections from an impedance mismatch caused by a fault.‡ Considering, for example, voltage components, the reflected signal will either aid or oppose the applied voltage, depending upon the relative phase of the two signals, and this phase relationship will depend upon the total phase change to the fault and back. The total phase change will be determined by the cable characteristics, the test frequency, the reflection coefficient of the fault and the distance to the fault. Assuming that the first two quantities are known, and that the angle of the reflection coefficient is constant, then the distance can be derived.

Thus, if the sending-end impedance of a faulty cable is plotted over a suitable frequency range the resulting impedance/frequency curve will have a superimposed ripple, caused by the successive phasing in and out of the transmitted and reflected signals over the frequency range. The distance between the successive peaks (or troughs), or "frequency interval" as it is commonly termed, in conjunction with the cable phase constant, can be used to determine the distance to the fault.

The magnitude of the ripple depends on the severity of the fault and the total attenuation to the fault and back; the more distant the fault, i.e. the greater the total attenuation, the smaller the ripple. The ultimate range of the method is, therefore, limited by the cable attenuation. Since this quantity is frequency dependent (decreasing as the frequency is lowered) the range of location can be increased by reducing frequency. A limit is reached where the change of cable characteristics with frequency is such as to affect the simplicity of the method, and indeed the basic assumption regarding the angle of the reflection coefficient becomes untrue for other than full reflections. However, these considerations only become important at frequencies below the range of the instrument to be described, i.e. if fault distances of hundreds of miles are being considered. For the range of location under consideration there is an optimum frequency range with which a fault can be located, and a portion of the frequency spectrum that gives a well-defined ripple is selected.

A possible disadvantage of the standard impedance/frequency method is the complex impedance/frequency response that is obtained if more than one impedance discontinuity exists on the line; individual fault location may then be difficult or almost impossible. However, as

† Test and Inspection Branch, E.-in-C.'s Office.

\* Patent Application No. 11567/61.

‡ BRAY, P. R. Fault Localization on Submarine Telegraph Cables by the Impedance/Frequency Method. Ph.D. Thesis, London University Library, 1956.

the majority of submarine-cable failures involve only a single major fault, usually a complete cable break, the above point was not considered to be greatly significant for the present purpose.

Fault location by the impedance/frequency method normally requires a considerable amount of test equipment—an oscillator and detector to cover the required frequency range, all the usual a.c. bridge components and a frequency-checking device. The procedure is somewhat lengthy because the measurement of the impedance/frequency characteristic from which the location is calculated normally entails many individual bridge balances by a skilled operator.

The equipment to be described has been designed to provide in a single portable unit all the facilities for performing rapid fault locations by the impedance/frequency method in a manner that requires no specialized knowledge or skill.

#### GENERAL DESCRIPTION

The instrument (Fig. 1) consists basically of a beat-frequency oscillator (b.f.o.) that delivers a substantially constant-current output to the terminating load. The magnitude of the output voltage is thus dependent upon the modulus of impedance of the load, and this voltage is monitored by a.c. amplifier-voltmeter circuits. When a faulty cable is connected to the output terminals, peaks and troughs on the impedance/frequency response can be readily seen when the b.f.o. is swept through a suitable frequency range.

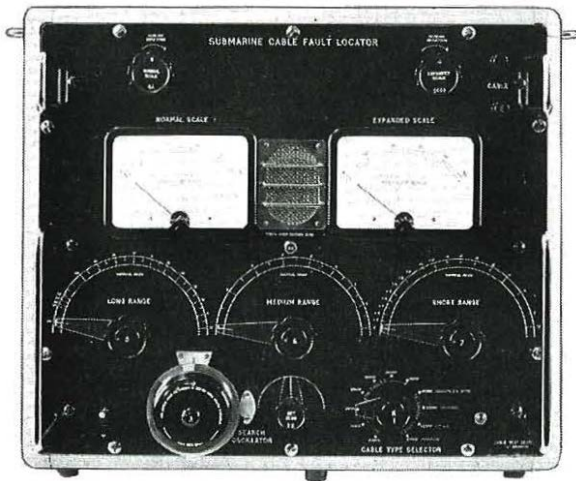

FIG. 1.—SUBMARINE-CABLE FAULT LOCATOR

Unlike the conventional b.f.o., however, both component oscillators are variable over a wide range. The first variable oscillator, the search oscillator, is used for exploring the frequency spectrum, from which a suitable peak (or trough) is selected, and the frequency is set precisely to this point. The second variable oscillator, the calibrated oscillator, is then adjusted until the next adjacent peak (or trough) is reached. This oscillator is scaled directly in nautical miles, so that the fault distance can be read-off directly. The frequency ranges of the b.f.o. depend upon the setting of the CABLE TYPE SELECTOR switch, which is set to correspond to the type of cable under test. Once the correct setting has been made, the nautical-mile calibrations of the second oscillator are applicable. The relationship between the distance to the fault and the change in frequency of the calibrated oscil-

lator is discussed in Appendix 1 and the method of obtaining an approximately linear milage scale is described in Appendix 2.

It can be shown (see Appendix 1) that if  $K$  is half the cable phase velocity (i.e. the normally accepted constant used for fault location) and  $L$  is the inductance in each oscillator, then if  $K\sqrt{L}$  can be maintained constant, the fault distance becomes a function of a single variable only, i.e. the reduction in value of the variable air-capacitor in the calibrated oscillator. This capacitor can accordingly be calibrated in nautical miles to the fault. For each different type of cable it is necessary to provide the correct value of inductance in the calibrated-oscillator tuned circuit so that the condition that  $K\sqrt{L}$  should be constant is always satisfied. In the fault locator being described it is assumed that the cable phase velocity (and thus also the value of  $K$ ) is constant over the frequency range of the calibrated oscillator. For most practical purposes, particularly on telephone cables, the assumption is sufficiently close to make negligible difference to the result. However, for long-range locations on some of the old telegraph cables for which low testing frequencies must be used, the assumption is less valid.

Some experimental work has been done on a method for automatically correcting for the change of velocity at the lower frequencies, but it is beyond the scope of this article. Allowance for velocity change in the present equipment can be made by selecting a lower  $K$  value for low-frequency fault-locations on telegraph cables. Should automatic velocity variation prove desirable, it may be incorporated in future equipment.

Returning to the present fault locator, the CABLE TYPE SELECTOR switch is set initially to correspond to the type of cable being tested, and this automatically connects the correct value of inductance into the tuned circuits of both oscillators, for the appropriate  $K$  value. A range of  $K$  values from 20,000 to 67,500 nautical-mile cycles/second is provided and this covers all types of submarine cables from the earliest telegraph cables to the modern polythene and semi-air-spaced types.

#### Long-Range Fault Location

For distant faults, or if the fault and cable impedances are similar, the fault ripple may be of very small magnitude. If a single meter only were used for displaying the cable impedance a fault ripple of a fraction of an ohm in, say, 50 or 60 ohms would hardly be discernible. To cater for faults of this type a second meter (the expanded-scale meter) is provided and this, by suitable setting of the associated gain control, magnifies any portion of the impedance/frequency response that may be selected. This meter considerably extends the range of the fault locator without in any way complicating the location of the more straightforward faults.

For the majority of cable-fault locations it should not be necessary to use frequencies below 2 or 3 kc/s. A possible exception will be distant faults in small-diameter gutta-percha telegraph cables for which it may be necessary to operate in the low audio-frequency region. Unfortunately, fault location at low frequencies is complicated by the rapid change in cable impedance that occurs with change of frequency, the net result of which is to mask or distort the fault ripple. As the frequency is reduced the cable impedance rises with increasing rapidity, and this would normally result in ever-increasing meter deflexion. To overcome this difficulty the fre-

quency response of the fault locator is made the inverse of the cable characteristic. Ideally, therefore, on a perfect cable the resulting overall meter deflexion is constant with frequency, and ripples on faulty cables are not masked by the steepness of the impedance/frequency characteristic. It is only necessary to employ this technique on the older small-diameter cables (to which the low-frequency response of the amplifier is equalized) as the lower attenuation of the modern cables normally permits the use of higher frequencies at which the impedance/frequency characteristic is substantially flat.

### Other Applications

The fault locator has been designed specifically for use on submarine cables, and nautical-mile calibrations have been used. No radical change is, however, required to use it on land cables, other than to provide the appropriate  $K$  constants. If these constants are in terms of statute miles, the milage scales are automatically related to statute miles without re-calibration. If required, the  $K$  constants can be made continuously variable by substituting a variable inductor for switched inductors.

As previously stated, impedance/frequency locations are considerably complicated by the presence of more than one major impedance irregularity, and the present fault locator is not really intended for use in such circumstances. However, its usefulness in such circumstances could be considerably extended by the addition of frequency scaling to the milage ranges, and impedance scaling to the meters and associated gain controls. In this way the fault locator could be used for obtaining comparatively rapidly an impedance/frequency graph, which in many instances would enable a trained operator to make a satisfactory location if two irregularities were present.

The main use for a modification of this type would be in fault location through a submerged repeater, as the frequency range of the fault locator extends into the low-attenuation band of some types of repeater power-separating filter. It should, therefore, be possible to detect impedance irregularities on the remote side of a repeater, but it would normally be necessary to use more elaborate methods for interpreting the results, as in the impedance/frequency bridge methods already employed.

### CIRCUIT DESCRIPTION

The circuit arrangement is shown in Fig. 2. Excluding the power-supply circuits, seven valves, three of which are double triodes, are used. The valves are soldered-in "reliable" types, and electrolytic capacitors are not employed.

The variable oscillators V1 and V2 employ a Colpitts-type circuit, as this avoids the complication of switching tapped or coupled coils for each  $K$  range. The coils are wound on small Aladdin formers through the centre of each of which a 6-B.A. brass screw can be screwed in or out to give a fine degree of adjustment. Identical coil sets, closely sited but screened from each other, are used in each oscillator and are switched by a common control. This ensures that the initial oscillator settings (fully anti-clockwise) give a low audio difference-frequency, so that zero setting is comparatively simple. In each of the variable oscillators the fixed capacitance has a much higher value than the variable capacitance, and so it has only been necessary to centre-tap the fixed portion of the capacitance, the variable portion being connected right across the tuned circuit. This avoids duplicating all the shaped-capacitance laws and reduces the size of the variable capacitors. The design of the oscillators is discussed further in Appendix 3.

As the fixed capacitance in the variable oscillators is relatively large, the scale shapes are completely independent of valve changes and aging effects. Also, as both oscillators are practically identical, their drift rate is similar and a stable difference-frequency is obtained. The instrument can therefore be used immediately after switching on as the location will not be affected due to warming up.

The modulator, V3A, is a triode operating under square-law conditions. A high-impedance low-pass-filter section is connected in the anode circuit and this filter attenuates the fundamental variable-oscillator frequencies and prevents them overloading the ensuing cathode-follower stage, V3B. This stage provides the necessary impedance conversion between the modulator and the low-pass filter.

The low-pass filter has a cut-off frequency of 435 kc/s and a design resistance of 200 ohms. It comprises two constant- $k$  sections, an  $m$ -derived section (having an infinity point at the lowest variable-oscillator frequency) and matching half-sections at each end to ensure that no peaks occur in the pass band of the filter.

It is, of course, essential that the overall frequency response of the fault locator should be quite smooth so that any ripples shown on the meters are due to cable-impedance deviations and are in no way introduced by the equipment. For this reason the amplifier following the low-pass filter employs overall automatic gain control (a.g.c.). This amplifier has three stages, V4, V5 and V6A, including a cathode-follower output stage (V6A), the a.g.c. being taken from the cathode of this valve to the grid of the first amplifying valve, V4. The response of the amplifier and associated a.g.c. circuits is shaped to give the inverse cable response, as previously

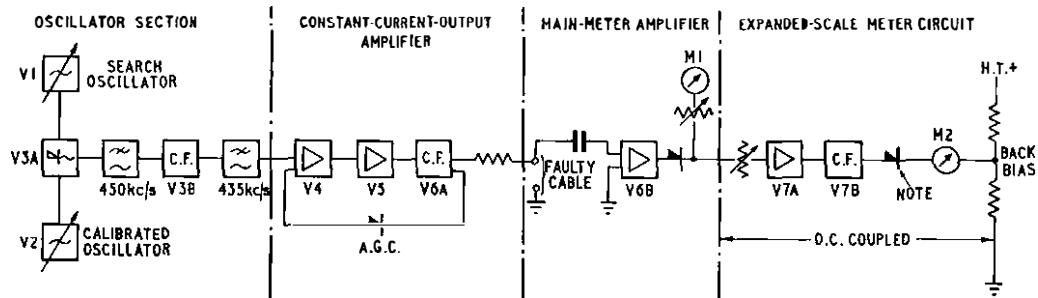

C.F.—Cathode follower Note: Prevents reverse deflexion  
 FIG. 2—BLOCK SCHEMATIC DIAGRAM OF FAULT LOCATOR

discussed. The shaping continues up to about 10 kc/s, above which the overall response of the system is substantially flat up to 420 kc/s.

The output of the cathode follower is taken to the cable terminals via a blocking capacitor and a 2,000-ohm series resistor. As this impedance is high compared with cable impedances, a substantially constant-current output is obtained.

An output for a high-impedance loudspeaker is taken, via a non-locking push-button and a blocking capacitor, from the cathode of the output stage.

The input to the meter amplifier is taken from the output terminals, across which the cable is connected, via a small blocking capacitor. The first stage in this amplifier, V6B, provides the necessary gain for the main meter M1 and ensures that there is no meter-loading effect on the cable impedance.

The expanded-scale meter M2 is direct coupled from the main meter via a 2-stage d.c. amplifier. The first of these two stages, V7A, provides the extra gain, and the second stage, V7B, is a cathode follower to provide the necessary low source-resistance for driving the backed-off expanded-scale meter. The backing-off voltage is obtained from a tapping across the h.t. supply; it is this voltage that determines the magnification of the expanded-scale meter relative to the main meter. Excessive magnification is not desirable for normal use because meter setting would become critical; it would have to be re-set more often and noise variations would be more prominent. A magnification of about 15 times has accordingly been provided as being the best sensitivity for general-purpose work. Direct coupling between the meter circuits is used to prevent the introduction of any relative frequency response between them, as such a response could easily give misleading results under certain fault conditions.

The gain of the main-meter amplifier decreases rapidly below the lowest test frequency (300 c/s) so that unwanted mains-frequency and earth-current interference is adequately rejected. Thus, several volts of hum pick-up on the cable (which would be much higher than normally encountered) does not in any way affect the fault location.

The meters are safeguarded from overload by Zener-diode limiting circuits. They do not introduce any scale cramping but they do ensure that under no condition can more than twice full-scale current flow through either meter.

As the mains supply voltage on some ships is liable to fluctuation, a stabilized h.t. supply has been used. The low output-impedance of this unit has allowed much individual stage decoupling to be dispensed with, thus permitting a reduction in the number of circuit components.

The inclusion of a transistor-type converter permits the set to be operated from batteries if required. Separate mains and battery leads are provided having multi-pin connecting sockets so arranged that when the appropriate lead is inserted the necessary connexions are automatically made for the method of operation selected. The individual h.t. and l.t. requirements are:

H.T. 70 mA at 250 volts.

L.T. 2.1 amp at 6.3 volts.

For battery working one 6-volt accumulator is required from which the drain is about 7 amp.

#### OPERATING PROCEDURE

Initially, certain controls, colour-coded with a green

dot, have to be set fully anti-clockwise. These controls are the variable-oscillator controls and the expanded-scale control. This setting ensures that the frequency is near zero and the expanded-scale meter is not in use. The controls are numbered in sequence of operation, and the operating procedure is as follows:

(a) The first control, the CABLE TYPE SELECTOR, is switched to correspond to the particular type of cable under test.

(b) The second operation is to set the b.f.o. to zero frequency. A small loudspeaker is provided to facilitate this operation, and it is brought into circuit by means of a non-locking push-button, thus permitting aural zero-setting.

(c) The search-oscillator frequency is varied and the fault ripple is investigated on the main meter.

(d) The gain control for the main meter is set so that peak deflexions are occurring close to full-scale deflexion.

Having obtained the correct gain setting and picked a suitable peak (or trough), the search oscillator is set precisely to this point. If the fault ripple is of small magnitude the expanded-scale meter can be brought into operation and this gives a magnification of about 15 times compared with the normal-scale meter. Thus, peaks or troughs caused by more distant faults can be accurately observed. The fault position is obtained by setting the second peak, using the calibrated oscillator, and reading the fault distance off the appropriate scale.

For normal faults the whole procedure can easily be completed and the location made in less than a minute.

Greater accuracy can be obtained if required by measuring the distance ( $2\pi n$  radians) over a number of peaks (or troughs)  $n$  and multiplying the final result by  $n$ , the number of peaks (or troughs) traversed. For example, if ten peaks ( $20\pi$  radians) are traversed by the calibrated oscillator and the setting of the tenth peak is 5.8 nautical miles, then the fault distance will be 58 nautical miles. This procedure tends to average out any setting error and may also be used for increasing the calibrated range of the fault locator.

Alternatively, should the fault be nearer than the minimum calibrated distance of  $\frac{1}{4}$  nautical mile, the distance between a peak and adjacent trough can be measured and the result halved. This, then, brings the minimum location range down to  $\frac{1}{8}$  nautical mile.

However, for the majority of locations the normal operating procedure gives satisfactory results and avoids unnecessary complication.

#### CONCLUSION

A submarine-cable-fault locator for use in cable ships has been described. The aim has been to produce a portable equipment that, with a minimum of complication, can be used for speedy and accurate location of faults on all types of cables.

The fault locator has been tried at the Post Office Submarine Cable Depot and has had considerable use aboard H.M.T.S. *Iris*.

The longest length of cable so far available for test has been 70 nautical miles of transatlantic-telephone-type 0.62 in. coaxial cable in the depot. Using more than one frequency interval (as previously described) precise locations could easily be made to the far end of the cable. The magnitude of the ripple obtained suggested that the location range could have been extended considerably on cable of this type.

Reports received from H.M.T.S. *Iris* show that a

number of successful locations have been made, with a good degree of accuracy. The fault locator has been found particularly useful when the ship has been working without co-operation from the shore.

ACKNOWLEDGEMENT

The authors desire to express their appreciation to Mr. L. J. Perry, of the Test and Inspection Branch, for his ingenuity in designing and making the capacitor interlock system (see Appendix 2).

APPENDIX 1

Relationship between Distance to Fault and Change in Frequency of Calibrated Oscillator

A typical impedance/frequency curve of a faulty cable, two adjacent peaks occurring at frequencies  $F_0$  and  $F_1$ , is shown in Fig. 3. If  $x$  is the distance to the fault, then:

$$x = \frac{K}{\Delta F} = \frac{K}{F_1 - F_0}$$

where  $K$  is the normally-accepted "constant" used in fault location and is numerically equal to half the cable phase velocity.

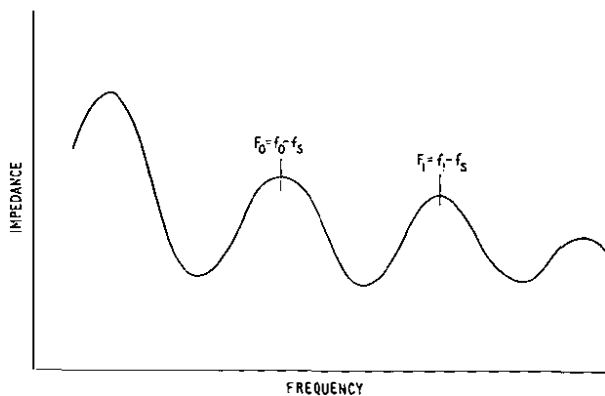

FIG. 3—TYPICAL IMPEDANCE/FREQUENCY CURVE OF A FAULTY CABLE

In the above example the output frequency of the b.f.o. is  $F$  having particular values  $F_0$  at the first selected peak and  $F_1$  at the next adjacent peak. The use of a b.f.o. having two component oscillators variable over a wide range enables the second (or calibrated oscillator) to be used for measuring the frequency interval ( $\Delta F$ ) only, and, as already indicated, this is inversely proportional to fault distance. The first oscillator is used only for setting the b.f.o. to a suitable peak (or trough)  $F_s$ , thus enabling the calibrated-oscillator control to commence from scale zero ("infinity") miles, because distance is inversely proportional to frequency change) and measure the frequency interval.

To avoid the possibility of misleading readings it is arranged that the minimum frequency to which the calibrated oscillator can be set is equal to the maximum frequency to which the search oscillator can be set. This corresponds to fully anti-clockwise rotation of both oscillator controls, and under these conditions let the frequency of each oscillator be  $f_0$ , the total tuning capacitance of each oscillator be  $C_m$  and the inductance of each be  $L$ .

At the commencement of a test, both component oscillators are set to  $f_0$  (infinity miles on the calibrated oscillator) so that the output frequency is zero. The search-oscillator frequency is then reduced until a suitable peak (or trough) is found to which it is precisely set; let its frequency at this point be  $f_s$ . The output frequency (Fig. 3) is then  $F_0 = f_0 - f_s$ .

The calibrated-oscillator frequency is then increased until the next adjacent peak (or trough) is located ( $F_1$  in Fig. 3); let the calibrated-oscillator frequency at this point be  $f_1$  and the reduction in tuning capacitance required to produce this frequency change be  $\delta C$ . Then, since the search oscillator setting has remained unaltered  $F_1 = f_1 - f_s$  and, therefore, if  $x$  is the distance to the fault,

$$x = \frac{K}{F_1 - F_0} = \frac{K}{(f_1 - f_s) - (f_0 - f_s)} = \frac{K}{f_1 - f_0}$$

$$= \frac{K}{\frac{1}{2\pi\sqrt{L(C_m - \delta C)}} - \frac{1}{2\pi\sqrt{LC_m}}}$$

$$\therefore x = \frac{2\pi K\sqrt{L}}{\frac{1}{\sqrt{C_m - \delta C}} - \frac{1}{\sqrt{C_m}}} \dots \dots \dots (1)$$

From equation (1) it is apparent that the distance to the fault,  $x$ , can be expressed in terms of the reduction in capacitance,  $\delta C$ .

APPENDIX 2

Milage Scale of the Calibrated Oscillator

To obtain the capacitance/distance law for the calibrated oscillator it is necessary to rearrange equation (1), Appendix 1; this gives:

$$\delta C = C_m - \left( \frac{x}{2\pi K\sqrt{L}} + \frac{x}{\sqrt{C_m}} \right) \dots \dots \dots (2)$$

This law has been plotted in Fig. 4 using the values of  $C_m$  and  $K\sqrt{L}$  applicable to the present design. Examination of the resulting curve shows that if a conventional type of variable air-capacitor had been used for the calibrated oscillator a very non-uniform milage scale would have been obtained.

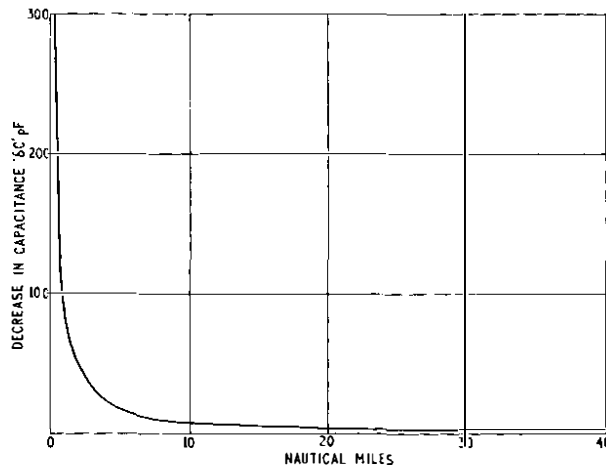

The curve reaches the limit 0 at infinite nautical miles.  
FIG. 4—DECREASE-IN-CAPACITANCE/DISTANCE LAW

This point will be more fully appreciated on considering that the difference between the  $\frac{1}{4}$  and  $1\frac{1}{4}$  nautical-mile settings is over 230 pF, whereas the difference between the 19 and 20 nautical-mile settings is about 0.2 pF, or, in terms of angular rotation of a linear variable capacitor,  $123^\circ$  and  $0.1^\circ$ , respectively. In other words, a 1-nautical-mile change at one end of the scale requires a change over a thousand times larger than a 1-nautical-mile change at the other end of the scale.

Although these particular figures relate to the present design, the type of law is basic to the impedance/frequency method of fault location and it explains why a frequency-checking device is normally essential for accurate locations over the longer distances if conventional oscillators are employed. To avoid the necessity for external frequency checking, an attempt has been made to approximate to the curve of Fig. 4 so that the correct rate of capacitance change is automatically obtained for any particular fault distance, and a substantially linear milage scale thereby obtained.

The total frequency range has been divided into three parts and a separate variable capacitor (of an appropriate size) used for each, so that three scales are obtained. These are termed the short, medium and long ranges, i.e.  $\frac{1}{4}$ -2, 2-10, and above 10 nautical miles, respectively.

Approximation to the required shape on each range is obtained by connecting a fixed capacitor in series with the variable capacitor so that the overall rate of capacitance change of the series combination is greater at the low-capacitance end. By choosing the correct ratio of fixed to variable values a close approximation to the curve can be obtained, and the technique

therefore permits the use of conventional linear variable capacitors. It should be noted, however, that it is essential that the calibrated oscillator is the one that increases in frequency from  $f_0$  and the search oscillator decreases from  $f_0$ . If the reverse had been so, this particular scale-shaping arrangement could not have been employed as it would have required a law of the reverse shape.

A limitation is imposed on the short-range capacitor by the largest practical size of air capacitor (about 1,000 pF) that can conveniently be used for a given required overall capacitance change. On the medium and long ranges the required overall capacitance changes are much smaller so that the optimum sizes of fixed and variable capacitors can be used.

For the long-range capacitor it was decided that a linear scale was desirable up to at least 20 nautical miles, cramping slowly after this and then rapidly as the distance becomes large. However, a further problem arises on this range as a result of the shaping procedure, for it follows that, having obtained the required very slow rate of capacitance change at the 20-mile end of the scale, the rest of the range between 20 nautical miles and infinity would also be opened out (infinity miles, of course, represents zero capacitance change). This would represent wasted scale as locations could not normally be made over very long distances because of the high attenuations involved. It is, therefore, necessary to build a small but rapid change of capacitance into the long-range capacitor so that the portion between the maximum useful distance and infinity is considerably compressed.

The rapid change of capacitance is achieved by having a small number of segments of blades a few degrees in width at the maximum-capacity end of the long-range capacitor in addition to the normal blades (see Fig. 5). As this capacitor is rotated

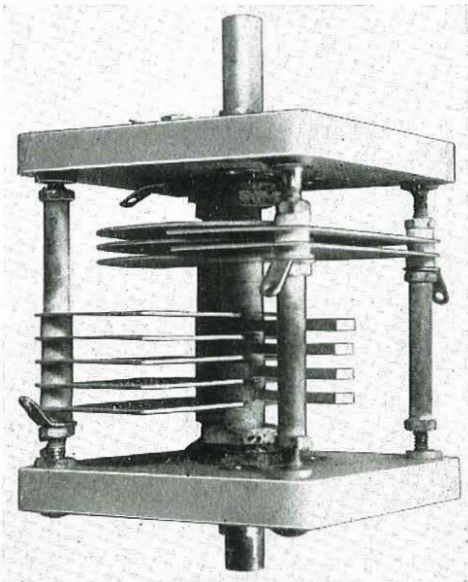

FIG. 5—CAPACITOR WITH RAPID-CHANGE SEGMENTS

there is an initial sharp drop in capacitance (of about 4 pF), and, when the frequency has increased to correspond to the greatest distance at which locations can be made, the rate of change is suddenly reduced (as the segments come out of mesh) and the mileage scale becomes linear. It is a simple matter to produce any required scale shape at this end of the scale simply by adjusting the number and size of the segments. The actual scale shapes obtained can be seen in Fig. 1 and the capacitor combination used to produce these scales is shown in Fig. 6.

It is, of course, necessary that the capacitors of the three ranges should be operated in the correct sequence, i.e. from the initial condition in which they are all at maximum capacitance they should be rotated in the order of long, medium and short range. To ensure that no misoperation can occur, an interlock system is used which ensures that when the capacitors are fully rotated anti-clockwise (i.e. against their end stops) the medium-

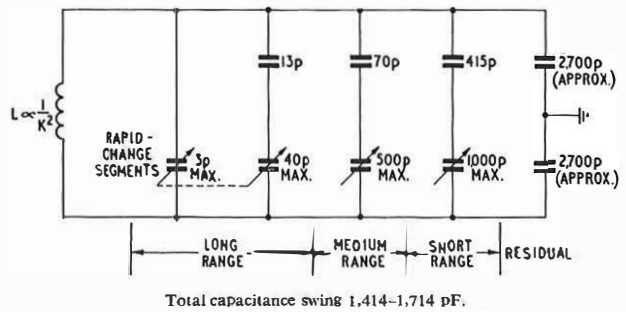

FIG. 6—CALIBRATED OSCILLATOR TUNED CIRCUIT

range and short-range capacitors are locked, allowing operation of the long-range capacitor only. If the peak (or trough) is not found before this capacitor has been fully rotated, the second capacitor is released and the first becomes locked. In a similar manner the second capacitor unlocks the third at the end of its travel and the first and second become locked. The correct operating sequence is thus always ensured.

### APPENDIX 3

#### Oscillator Design Considerations

The required frequency ranges of each variable oscillator are decided by the minimum location range and the range of  $K$  values provided. Assuming a minimum distance of a  $\frac{1}{4}$  nautical mile for a phase change of  $2\pi$  radians (i.e. the distance between successive peaks or troughs), then  $\Delta F_{max} = (F_1 - F_0)_{max} = K/\frac{1}{4} = 4K$ , and this represents the maximum swing of the calibrated oscillator.

The frequency swing of the search oscillator must be sufficient to ensure finding at least one peak or trough. It may sometimes be necessary to provide a frequency range equivalent to a total phase shift of at least  $\pi$  radians on the shortest distance. This represents a frequency swing of half the calibrated oscillator swing ( $4K$ ), but a 10 per cent safety margin has been added, making the maximum swing of the search oscillator  $2.2K$ .

On the highest frequency range, i.e.  $K = 67,500$  (Styroflex cable), the total swing of the calibrated oscillator is therefore  $4 \times 67,500 = 270$  kc/s and that of the search oscillator is  $2.2 \times 67,500 = 148.5$  kc/s. The highest output frequency of the b.f.o. is thus  $270 + 148.5 = 418.5$  kc/s and the low-pass filter must pass all frequencies up to this limit.

The frequency range of the variable oscillators (as distinct from the swing) is  $f_0 + 4K$  for the calibrated oscillator, and  $f_0 - 2.2K$  for the search oscillator. The actual value of  $f_0$  selected is a compromise to give good stability of the difference frequency (for which  $f_0$  must be kept low) and a minimum of intermodulation products in the final b.f.o. output. The lowest-order product that it is necessary to reject can be shown to be  $3f_L - 2f_H$ , where  $f_L$  and  $f_H$  are the lower and higher frequencies, respectively. This product has been kept above 500 kc/s to allow adequate margin for the low-pass filter. In the limit, therefore,

$$3(f_0 - 2.2K) - 2(f_0 + 4K) = 5 \times 10^5$$

$$f_0 = 14.6K + 5 \times 10^5 \dots \dots \dots (3)$$

The value of  $f_0$  is thus dependent upon the  $K$  value, and provided the above condition is satisfied at the minimum  $K$  setting (i.e.  $K = 20,000$ ), then for progressively higher  $K$  values (i.e. higher values of  $f_0$ ), the product  $(3f_L - 2f_H)$  lies increasingly further away from 500 kc/s.

The last remaining quantity to be determined is the size of the variable capacitor in the calibrated oscillator. For good frequency-stability this should be large, but it must be remembered that the scale-shaping techniques, already discussed, reduce the available capacitance swing of the series combination. The total swing of the calibrated-oscillator capacitor network has been fixed at 300 pF, to give a good compromise between frequency stability, scale shape, and physical size of the actual variable capacitors. This capacitance swing must, therefore, be arranged to give a frequency deviation of  $4K$  on each range. The tuned-circuit components for each  $K$  range can now be calculated by applying equation (3) to the minimum range and ensuring that  $K\sqrt{L}$  is maintained constant on each range.

# A Speech Compressor Using Junction Transistors

D. THOMSON, A.M.I.E.E.†

U.D.C. 621.395.665.1:621.382.333

A compressor has been designed that makes use of the properties of the base-emitter junction of the germanium transistor to give a better approximation to the desired compression/expansion law than has previously been obtainable without selection or matching of transistors. The principles affecting the design are outlined, and the circuits and performance of the new compressor are described. Small quantities of the compressor are being manufactured commercially for the Post Office and some have already been used to improve the signal-to-noise ratio on certain channels in the transatlantic telephone cable.

## INTRODUCTION

SPEECH volume-range compressors have been used for many years. Their purpose is to reduce the effects of noise and interference (e.g. crosstalk), and they are capable of giving a subjective improvement in signal-to-noise ratio of up to about 25 db. In this country the use of compressors has been confined to a few telephone circuits (e.g. some submarine-cable circuits and radio-link channels) where it would be difficult to achieve the desired signal-to-noise ratio by other means. Transmission systems exist in which the designer has taken advantage of the compressor improvement in order to relax the noise and crosstalk requirements of the transmission system of which compressors form an integral part. Examples of these are the N1 Carrier System<sup>1</sup> designed by Bell Telephone Laboratories and now in widespread use in the U.S.A. and an experimental short-haul carrier system designed at the Post Office Research Station for use on unloaded audio cables<sup>2</sup>.

A speech compressor has now been designed in which junction transistors are used as controlled elements in the variable-loss circuits as well as for rectification and amplification. Use has been made of the properties of the base-emitter junction of the transistor to achieve a closer approximation to the desired compression/expansion characteristic than has previously been possible without the special selection or matching of transistors.

Compressors of the new type described in this article are in use on some telephone channels on the TAT-1 transatlantic telephone cable system.<sup>3</sup> Since this transatlantic telephone cable was laid its attenuation has gradually decreased, and in consequence the transmitted signal level has had to be reduced to avoid overloading the submarine repeaters. As a result, the signal-to-noise ratio of some channels has fallen below an acceptable value and compressors have been added to those channels.

The use of time assignment speech interpolation (T.A.S.I.)<sup>4</sup> equipment on the TAT-1 system means that the listener, during the course of one call, may be presented with a succession of channels some of which may include compressors. If the compressors are used in such a way as to provide the full subjective advantages of which they are capable, the listener is disturbed when switched from a channel without a compressor to one equipped with a compressor and which, therefore, gives the impression of being excessively quiet. Arrangements have therefore been included in the design to enable the noise advantage to be preset to a value suitable for the channel concerned.

† Post Office Research Station.

## PRINCIPLES OF COMPANDOR OPERATION

The principles of operation of compressors and the advantages to be gained from their use have been discussed in the literature,<sup>5,6,7,8</sup> but for completeness they will be described briefly here.

The gain of the compressor at the sending end of the circuit is made to vary inversely as the level of the transmitted signal, i.e. the gain is greatest for the weakest signal. The weaker components of the signal are thus given a "compressor advantage" over the noise or crosstalk occurring after the compressor. The gain of the expander at the receiving end of the circuit is made to vary directly as the level of the received signal, i.e. the gain is least for the weakest signal. It follows that the gain of the expander is least when there is no signal and only noise or interference is present.

The speed with which the gains of the compressor and expander follow the fluctuations in speech volume of the talker can be made such that, during the silent intervals between words and syllables, the gain of the expander is under the control of the circuit noise and is therefore low, while in the non-silent intervals the gain of the expander is high and is offset by the low gain of the compressor. If the compressor and expander are complementary there is no net gain to an input signal, but the expander action reduces the noise in the silent periods. This "expander advantage," added to the compressor advantage described above, produces a substantial subjective improvement in signal-to-noise ratio.

The compressor described in this article, in common with those developed in the past for similar applications, has a compression/expansion ratio of 2 : 1 on a decibel scale. This ratio has been used because it gives a worthwhile improvement in signal-to-noise ratio, is obtained in a straightforward way and, in this design, applies over a range of signal levels exceeding 65 db, which is sufficient to accommodate the range of talker levels encountered in practice.

## BASIC CIRCUITS

The basic circuit of the compressor is shown in Fig. 1. The variable-loss network is followed by an

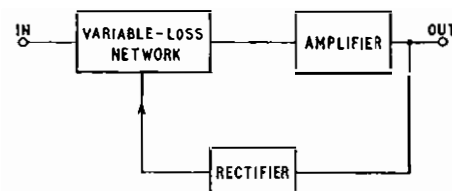

FIG. 1—BASIC CIRCUIT OF COMPRESSOR

amplifier having a high gain and providing a subsidiary output which, after rectification, controls the loss of the variable-loss network. A 2 : 1 compression ratio is achieved if, over the required range of signal levels, the control current is directly proportional to the level of the signal at the input to the rectifier and the gain of the



variable-loss network is inversely proportional to the control current.

In the basic circuit of the expander (Fig. 2) a fraction of the input is rectified to provide current to control the variable-loss network. A 1 : 2 expansion ratio results if

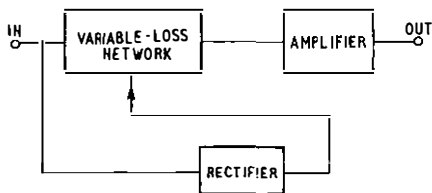

FIG. 2—BASIC CIRCUIT OF EXPANDER

the control current is directly proportional to the level of the signal at the input to the rectifier and the gain of the variable-loss network is directly proportional to the control current.

### Variable-Loss Circuits

In both compressor and expander the controlled elements in the variable-loss network are the a.c. resistances of the emitter-base junctions of germanium junction transistors. A fundamental property of such a junction is that the a.c. resistance is inversely proportional to the unidirectional current flowing in it. Fig. 3 shows that over a range of control current extending from about  $10 \mu\text{A}$  to about  $500 \mu\text{A}$  (i.e. a range of more than 30 db) the a.c. resistance is inversely proportional to the control current to within an accuracy of 0.5 db. It is

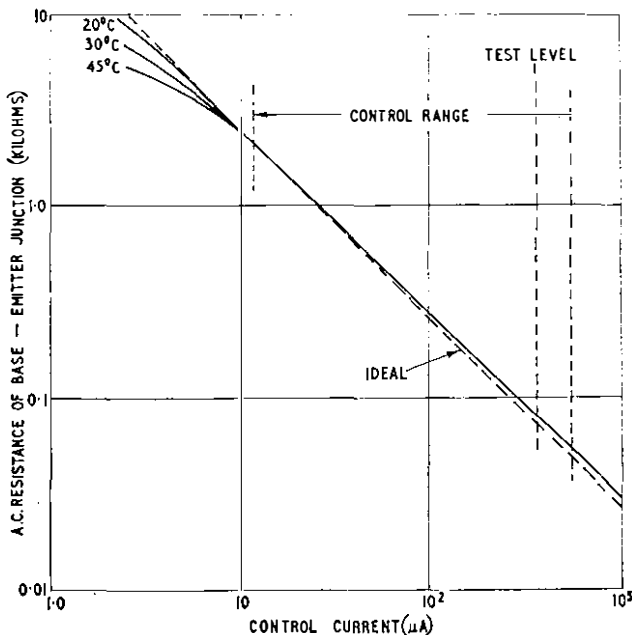

FIG. 3—JUNCTION TRANSISTOR: A.C. RESISTANCE/CONTROL-CURRENT CHARACTERISTIC

important that this characteristic should vary little from sample to sample in order that similar compression/expansion characteristics will be obtained from all companders. In practice the greatest spread of a.c. resistance/control-current characteristic in the range  $10 \mu\text{A}$  to  $1 \text{mA}$  occurs at the high-current end and, for the type of transistor used, amounts to 7 per cent approximately.

In the past, other devices used as variable-loss circuit elements have included copper-oxide rectifiers<sup>6</sup> and germanium point-contact diodes,<sup>7</sup> and it has been found necessary to select and match the devices in pairs to achieve the required degree of balance in the variable-loss networks, thus preventing harmonic currents generated in the control-current rectifier from appearing as signals in the transmission path. Oven-control of temperature has sometimes been used to avoid excessive departure from the ideal characteristic.

The variable-loss circuits are shown in Fig. 4 and 5.

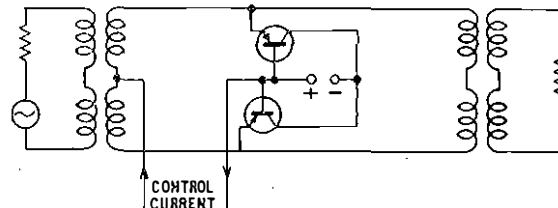

FIG. 4—COMPRESSOR VARIABLE-LOSS CIRCUIT

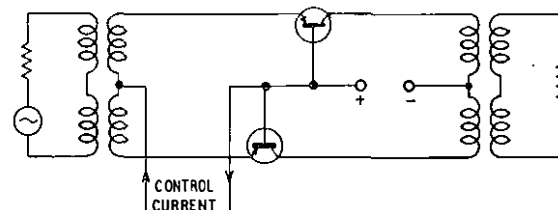

FIG. 5—EXPANDER VARIABLE-LOSS CIRCUIT

In the compressor circuit the a.c. resistances of two junctions are used in series as a shunt between generator and load resistances, each of which is much greater than the greatest value reached by the junction resistances within the range of control current used. The expander variable-loss circuit is novel in that the transistors used as controlled elements also provide useful gain. The circuit is effectively a single-stage push-pull common-base amplifier. The voltage gain of such an amplifier operating into a constant load resistance is almost exactly inversely proportional to the input resistance of the transistors. This varies with the control current as shown in Fig. 3, so that the gain of the circuit can be made directly proportional to the control current by driving the circuit from a source resistance that is very low compared with the lowest value reached by the junction resistances over the range of control current used. The variable-loss elements are non-linear and therefore introduce distortion; this is kept to an acceptably low level by arranging that the ratio of control current to signal current in these elements is sufficiently large.

### Control-Current Rectifier

The control-current rectifier is identical in compressor and expander and is shown in Fig. 6. It consists of a common-base junction transistor having no emitter bias and in which half-wave rectification takes place in the emitter-base junction. The very high output impedance of the collector circuit makes the performance of the rectifier almost independent of the collector load resistance, which varies widely with control current. The input-level/control-current characteristic of the rectifier is shown in Fig. 7.

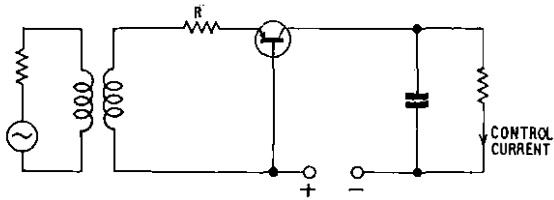

FIG. 6—CONTROL-CURRENT RECTIFIER

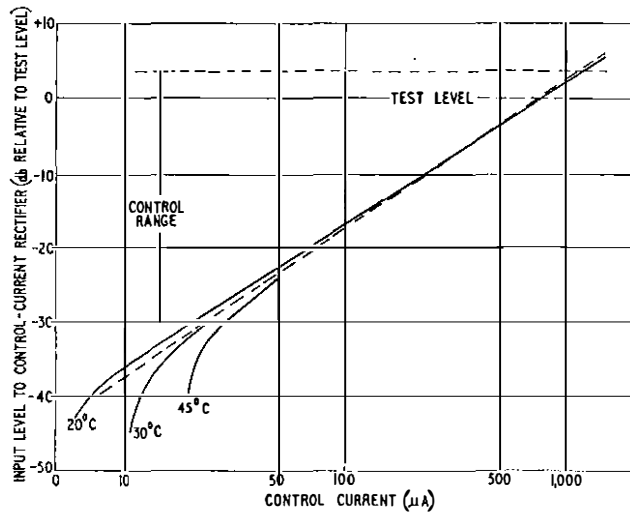

FIG. 7—CONTROL-CURRENT RECTIFIER: INPUT-LEVEL/CONTROL-CURRENT CHARACTERISTIC

The characteristic departs from the ideal at low currents and high ambient temperatures because the collector cut-off current augments the control current at low signal levels. The error can easily be corrected by causing the collector cut-off current of a similar transistor to flow in the rectifier load circuit in opposition to the control current. Compensation can be accurate because there is little variation between transistors in the coefficient of increase of collector cut-off current with increase of temperature.

Compressor

The compressor has been designed so that, when a test signal at a level of 0 dbm\* (test level) is applied at the origin of a circuit in which it is included, the input level to the compressor is -14 dbm and the output level -2 dbm; the control current corresponding to this condition is 750 μA. The frequency response is flat to within 0.5 db from 300 c/s to 3.4 kc/s, and the input and output impedances, expressed as return losses against 600 ohms, exceed 20 db at 1 kc/s and 15 db at 300 c/s and 3.4 kc/s. The total harmonic distortion for an input signal 7 db above test level is less than 5 per cent.

Fig. 8 shows the circuit of the compressor. R1 provides the required input impedance and also ensures that the level of signal current in the variable-loss elements is always well below the control current. The high-gain amplifier, consisting of transistors VT4, VT5 and VT6, provides two outputs; the normal signal output is obtained via transformer T3, and an output to supply the control-current rectifier circuit is provided via transformer T4. The primary windings of T3 and T4 are fed in series in the high-impedance collector circuit of the output transistor VT6, and this ensures that the amount of coupling between output and control circuits is sufficiently small.

The amplifier has a fixed gain of about 55 db, with about 20 db of negative feedback applied over the three stages by means of R14. This type of feedback increases the input and output impedances of the amplifier and the required output return loss is obtained by means of R17. The d.c. operating conditions of the amplifier are stabilized in a conventional manner. The transistor VT1 provides temperature compensation. In practice, it has not been found necessary to match transistors VT1 and VT7 for equal collector cut-off currents at equal temperatures. It has been found that, if R2 is selected to give the required compression ratio at 45°C, the performance is adequate at lower temperatures.

\* dbm—decibels relative to 1 milliwatt.

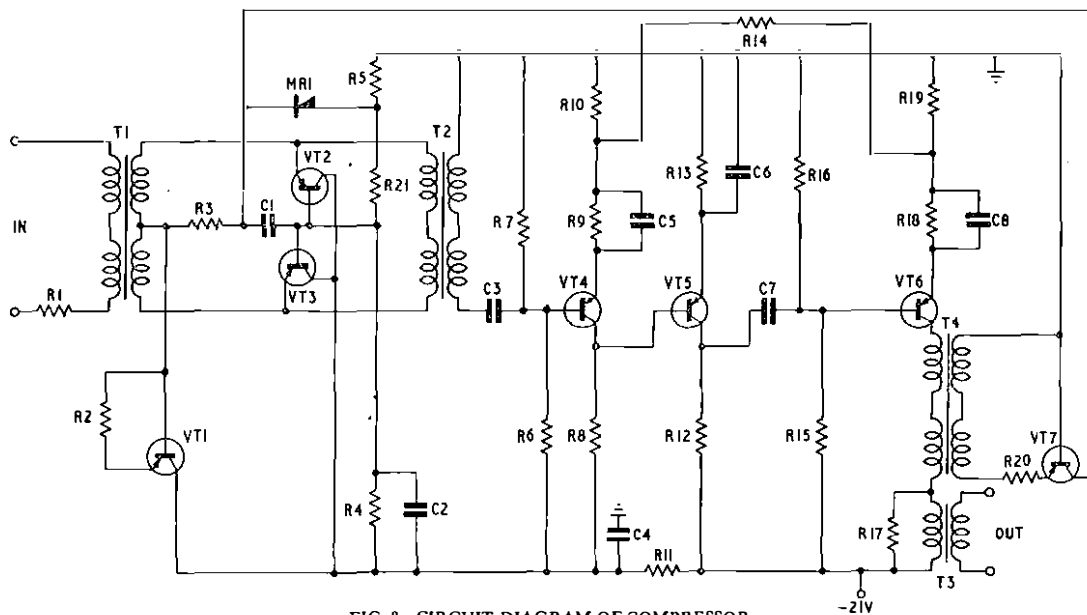

FIG. 8—CIRCUIT DIAGRAM OF COMPRESSOR

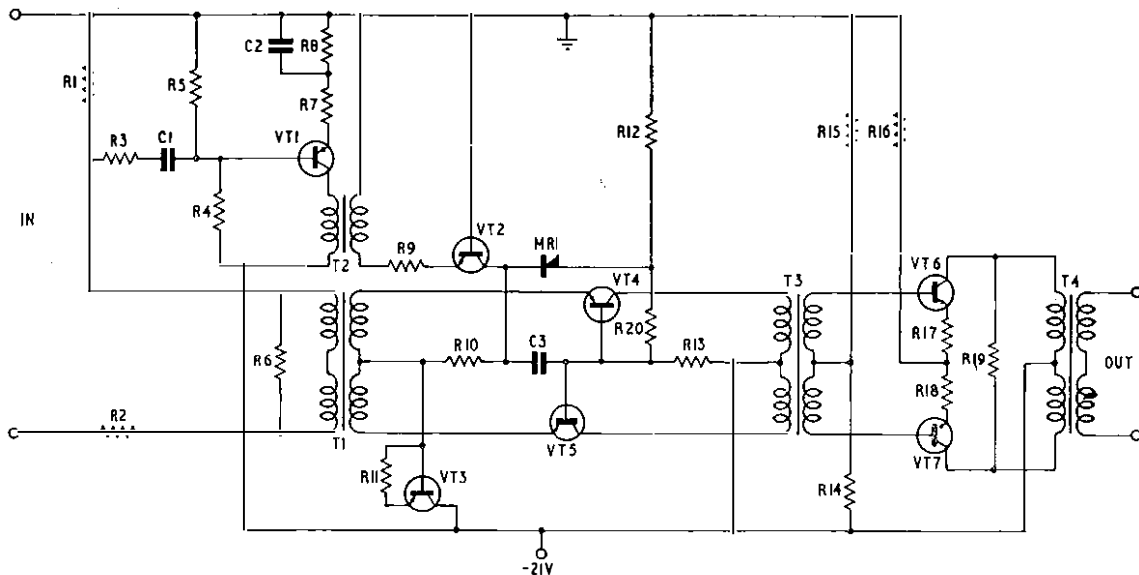

FIG. 9.—CIRCUIT DIAGRAM OF EXPANDER

### Expander

Test level for the expander corresponds to an input level of 0 dbm, an output level of +10 dbm and a control current of  $750 \mu\text{A}$ . The frequency response and input and output impedances are the same as those of the compressor. The total harmonic distortion for an output signal 7 db above test level is less than 5 per cent. The circuit is shown in Fig. 9.

The input signal is divided, by means of R1, R2 and R6, to supply an input to the signal path via transformer T1, and an input to the control-current pre-amplifier VT1. Resistor R6 provides the required low source resistance for the variable-loss circuit, and resistors R1 and R2 provide the required input impedance and ensure that the level of signal current in the variable-loss elements is always well below the control current. The variable-loss network is followed by a single-stage push-pull amplifier of conventional common-emitter type having a gain of about 30 db with approximately 10 db of negative feedback applied by means of R17 and R18. The high output impedance of the stage is reduced to the required value by means of R19.

### COMPRESSION/EXPANSION CHARACTERISTICS

Because the variable-loss circuit in the compressor depends for its action on shunt elements and in the expander on identical series elements, the departures from the ideal compression/expansion laws are largely complementary. The ideal characteristics have been obtained over an input-signal-level range extending from 7 db above test level to 60 db below test level within an accuracy of  $\pm 1.2$  db for either the compressors or the expanders. For tandem connexion of compressor and expander the errors do not exceed  $\pm 0.5$  db. Typical error characteristics are shown in Fig. 10.

### ADJUSTMENT OF NOISE ADVANTAGE

The "no-signal" noise advantage may be adjusted by reducing the level of signal sent to line by means of an attenuator following the compressor and by compensating for this loss by inserting additional gain at the receiving end before the expander. This method suffers

from the disadvantage that some of the compressor advantage in the "signal-on" intervals is lost.

A better method is to restrict the range of signal levels over which the compression/expansion law holds by arranging that at a predetermined signal level the 2:1 law changes to 1:1. This can easily be done by injecting a clamping current via a diode into the variable-loss networks so that, as the signal level is reduced below the predetermined value the control currents, and therefore the gains of compressor and expander, cannot change.

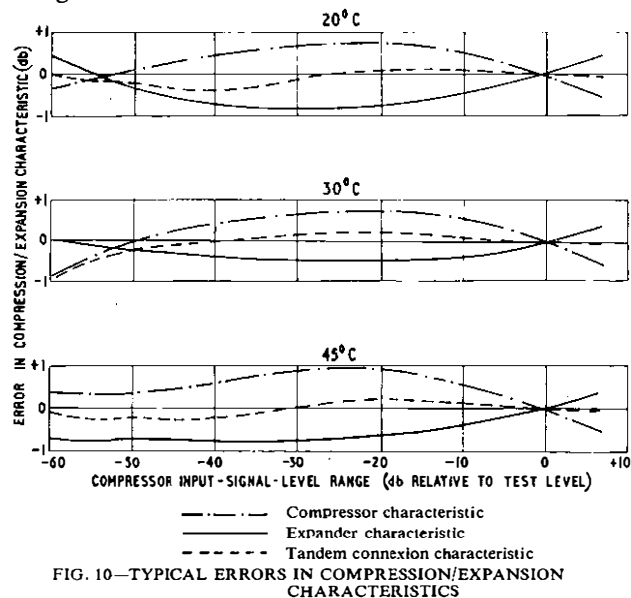
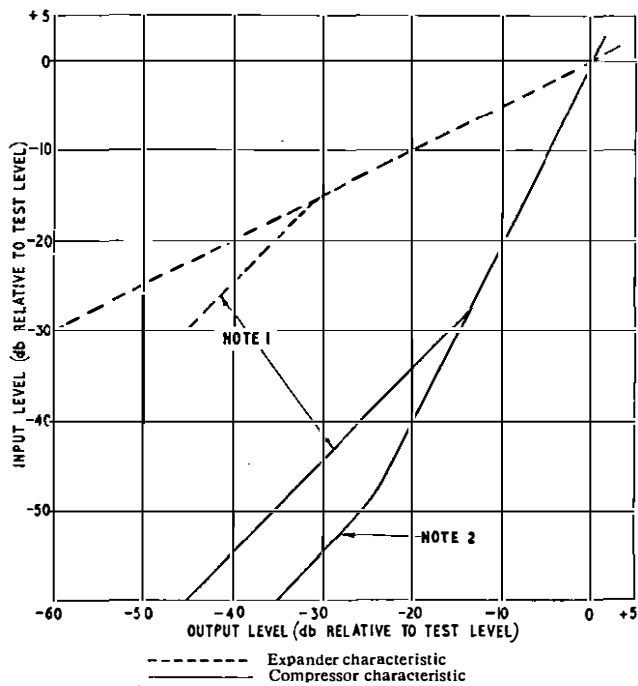

FIG. 10—TYPICAL ERRORS IN COMPRESSION/EXPANSION CHARACTERISTICS

The second method has several advantages over the first. The low-level region of the control-current range, where temperature compensation is used and there is greatest possibility of error, is only used when the full noise advantage is required. A better transient response is obtained because the maximum change of gain on receipt of a signal (e.g. a signalling pulse) is reduced, while no additional gain is required at the receiving end of the channel preceding the expander.

Components R21 (preset) and MR1 (see Fig. 8) and R20 (preset) and MR1 (see Fig. 9) have been added to the original design to give the facility of varying the noise advantage. Fig. 11 shows a typical compandor input/output characteristic clamped at a point corresponding to 30 db below test level at the input to the compressor. Because the maximum change of gain of expander (relative to its gain at test level) that can occur is reduced to 15 db by means of this clamp, the maximum no-signal noise advantage obtainable is 15 db.



Notes: 1. Input/output characteristic clamped at 30 db below test level at input to compressor.  
 2. Control current clamped to a value corresponding to a signal level 50 db below test level at compressor input.

FIG. 11—TYPICAL INPUT-LEVEL/OUTPUT-LEVEL CHARACTERISTICS

#### ATTACK AND RECOVERY TIMES

The requirements of a speech compandor regarding speed of operation have been discussed previously.<sup>1,6</sup>

A signal applied suddenly to the input of the compressor may be subjected to an initial excess gain of more than 30 db, and this condition will tend to persist until the control-current reaches the appropriate value, the period depending on the time constant of the control-current rectifier load circuit. This interval, the "attack time," must be made short to avoid excessive distortion

that may be produced by overloading the output stage of the compressor or the transmission channel itself. Signalling pulses are less tolerant of this distortion than are speech signals, and it has been found desirable to restrict the initial excess gain of the compressor by clamping the control current at a value corresponding to a signal level at the compressor input of 50 db below test level. This is shown in Fig. 11.

The interval between the cessation of a signal and the steady state, i.e. the "recovery time," must be short enough to ensure that the advantage of low gain in the expander is obtained in the intervals between words and syllables. On the other hand, the time constants should not be so short that the compressor and expander gains can follow the waveform of the lowest signal frequency in the band to be transmitted.

In order that the received signal shall be as nearly as possible an exact replica of that transmitted, the control-current rectifiers and their load circuits, and therefore the attack times (4-5 ms) and recovery times (13-17 ms) of compressor and expander, have been made identical within the limits of component tolerances. Subjective tests have shown that these attack and recovery times are satisfactory for good speech quality.

#### CONCLUSION

Compandors of the type described above are being manufactured commercially for the Post Office. Orders have been placed for about 250, and some have already been installed on certain channels of the TAT-1 system. The orders include 180 which will be used on another transatlantic telephone cable system, the TAT-3 system.

#### References

- <sup>1</sup> CARUTHERS, R. S., KAHL, W. E., and PEDERSEN, L. The NI Carrier System. *Bell System Technical Journal*, Vol. 30, p. 1, Jan. 1951.
- <sup>2</sup> REYNOLDS, J., JEYNES, E., TURNER, D., THOMPSON, C. D., and CROSSLEY, J. The Design and Field Trial of a 12-Circuit Carrier Telephone System for use on Unloaded Audio Cables. *P.O.E.E.J.*, Vol. 50, pp. 173 and 252, Oct. 1957 and Jan. 1958.
- <sup>3</sup> The Transatlantic Telephone Cable. *P.O.E.E.J.*, Vol. 49, Part 4, Jan. 1957.
- <sup>4</sup> CLINCH, C. E. E. Time Assignment Speech Interpolation (T.A.S.I.). *P.O.E.E.J.*, Vol. 53, p. 197, Oct. 1960.
- <sup>5</sup> LAWTON, J. Compandors for Reducing Noise and Crosstalk. *A.T.E. Journal*, Vol. 2, p. 109, 1953.
- <sup>6</sup> CARTER, C. W., DICKIESON, A. C., and MITCHELL, D. Application of Compandors to Telephone Circuits. *Transactions of the American I.E.E.*, Vol. 65, p. 1079, 1946.
- <sup>7</sup> JARVIS, J. R. A Compandor for a 12-Circuit Carrier System for Use on Unloaded Audio Cables. *P.O.E.E.J.*, Vol. 51, p. 29, Apr. 1958.
- <sup>8</sup> THOMSON, D. A Compandor Using Junction-Transistors. *Proceedings I.E.E.* Paper No. 2868 E, June 1959 (Vol. 106, Part B, Supplement No. 16, p. 619).

## Book Received

"Radio Valve Data." Seventh Edition. Published for *Wireless World* by Iliffe Books, Ltd. 156 pp. 6s. (6s. 10d. post paid).

The latest edition of "Radio Valve Data" has been compiled by the staff of *Wireless World* in co-operation with 20 British manufacturers and distributors. It has been enlarged again, and now contains operating data for over 4,800 British and American radio valves, semiconductor devices, rectifiers and cathode-ray tubes.

The main tables have been based on a classification of the devices by function, then by manufacturers' names and finally into current, replacement or obsolete types. The index to the book, which covers all the individual items included in the main tables, has been arranged so that alongside each entry referring to a valve there is, in addition to the page number, information regarding the base-connection code and, where appropriate, the equivalent valve types.

# An Audio-Frequency Transmission Measuring Set Using Transistors

K. W. LEE, B.Sc., A.M.I.E.E., and K. S. RATCLIFFE†

U.D.C. 621.317.743 : 621.382.3

An audio-frequency transmission measuring set using transistors has recently been introduced. The use of transistors not only enables the weight of the set to be considerably reduced in comparison with an equivalent valve-type set, but also makes it practicable to operate the set from dry batteries that are contained within its case. The instrument thus has the advantages of being easily portable and of being independent of an external power supply.

## INTRODUCTION

THE advantages of low power consumption and small size offered by the use of transistors make it possible to design portable transmission testing equipment that is of light weight and capable of operating from a self-contained battery having a reasonable life. A battery power supply is essential at sites where a.c. mains are not available and is also a great convenience in many other places, such as subscribers' premises.

The development of transistor-type transmission testing equipment has started with audio-frequency apparatus, and the first item to become generally available is a precision audio-frequency transmission measuring set, Measuring Set No. 26.

## GENERAL DESCRIPTION

The new transmission measuring set (Fig. 1) comprises an audio oscillator, giving a choice of 14 fixed frequencies, and a level measuring set suitable for measuring



FIG. 1—MEASURING SET NO. 26

both through and terminated levels on balanced or unbalanced circuits of 600 ohms impedance. For the initial design a maximum oscillator output of 1 mW was accepted, due to the limitation imposed by the types of transistor available at the time the design was commenced. This version of the set is operated by a battery

† Mr. Lee is with Standard Telephones and Cables, Ltd., and Mr. Ratcliffe is in the Main Lines Development and Maintenance Branch, E.-in-C.'s Office.

of six dry cells (U2 type) and has a current consumption of 17 mA.

An oscillator output of 10 mW was always regarded as one of the objectives of the design, and this has now been achieved in a later model, but the improved performance has increased the current consumption to 28 mA and has necessitated increasing the size of the battery to eight U2-type cells.

Metal carrying-cases are used for both models of the measuring set, and the batteries are housed in a separate compartment within each case. Much thought was given to the design of the battery box to ensure that:

- (a) the battery cannot be connected to the equipment if the cells are assembled with reversed polarities,
- (b) the cells are under adequate spring pressure to ensure reliable contacts, and
- (c) the battery-box contacts make good contact with the dry-cell terminals.

The materials and finish used in the construction of the battery box are resistant to corrosion that might result should the dry battery deteriorate due to neglect in service. The box is also sealed off from the equipment to minimize corrosion damage.

In view of the comparatively large current that would have been required by a conventional panel lamp to indicate when the set was switched on, such an indication was not provided on the initial design. However, experience gained with this model confirmed the need for some positive indication when the set was switched on, and in the later version the on/off switch is coupled mechanically to a coloured indicator flap that is displayed when the set is in use. A microswitch is also fitted, and this cuts off the battery supply when the lid of the carrying case is fitted, thus providing a safeguard against leaving the set switched on during storage or transit.

Separate meters are provided for the sending and receiving circuits. The oscillator meter is used to set the correct sending level and also to check the battery voltage, so that an indication can be obtained that the batteries need replacement. The oscillator output level is adjustable over a small range to enable the correct sending level to be obtained.

The oscillator frequencies are arranged so that 800 c/s appears on the first position of the frequency-selection switch (i.e. before 300 c/s). This is to avoid the oscillator output passing through 800 c/s when loss/frequency measurements are being made over connexions set up via the trunk network, since pulses of 800 c/s tone might clear down a connexion set up over a link using Signalling System A.C. No. 1. Similarly, 2,200 c/s has been omitted to avoid possible difficulties on circuits using Signalling System A.C., No. 9.

## CHARACTERISTICS

### *Sending Circuit*

*Frequencies:* 300, 400, 500, 600, 800, 1,000, 1,600, 2,000, 2,400, 2,600, 2,800, 3,000, 3,200 and 3,400 c/s.

*Frequency Accuracy:* better than  $\pm 3$  per cent.

*Harmonic Content:* less than 2 per cent.

*Sending Levels:* +10, 0, -10, -20, -30 dbm\* into 600-ohm balanced or unbalanced circuits.

*Sending-Level Accuracy:* better than  $\pm 0.5$  db.

*Return Loss (against 600 ohms):* better than 30 db.

**Receiving Circuit**

*Frequency Range:* 300 c/s-15 kc/s.

*Measuring Range:* +25 dbm to -30 dbm on 600-ohm balanced or unbalanced circuits. Both through and terminated levels can be measured.

*Measuring Accuracy:* better than  $\pm 0.5$  db.

*Bridging Loss:* less than 0.2 db for through levels.

*Return Loss (against 600 ohms):* better than 30 db.

**Dimensions**

16 $\frac{3}{4}$  in.  $\times$  13 in.  $\times$  5 $\frac{1}{4}$  in.

**Weight**

18 lb.

**CIRCUIT DESCRIPTION**

**Sending Circuit**

The circuit consists of a 2-stage spot-frequency oscillator followed by a 2-stage output amplifier. The oscillator circuit comprises the transistors VT1 and VT2 arranged as a 2-stage amplifier with positive feedback applied via a Wien bridge network and negative feedback applied via a thermistor, TH. A simplified circuit diagram is shown in Fig. 2.

\* dbm—decibels relative to 1 milliwatt.

The Wien bridge is the frequency-determining network and is formed by C20 and R12 in series in one arm, with the parallel combination of C31 and R13, R14 and R2 in the other arm. The oscillator frequency is varied by means of the frequency-selector switch, which changes the capacitance of C20 and C31 as required.

It can be shown that if C20 is equal in value to C31, and the resistance of R12 is equal to that of the parallel combination R13, R14 and R2, the voltage loss in the bridge at resonance is 3 (i.e. the ratio of input to output voltage is 3 : 1). The oscillation frequency,  $f$ , is given by  $2\pi f = 1/(C_{20} \times R_{12})$ . Thus, for oscillation to take place the amplifier must have a voltage gain of 3 and a phase change of  $360^\circ$  overall.

The parallel arm of the bridge is shunted by the input impedance of transistor VT1, and the series arm has the output impedance of VT2 in series with it; these impedances will therefore affect the frequency. By using a high-gain amplifier and reducing the gain to the required value (3) by negative feedback, the amplifier output impedance is reduced and the input impedance increased to such values that their effects become almost negligible.

With the transistors arranged in common-emitter configuration, considerable phase shift can occur even at audio frequencies, with consequent large changes of frequency in the event of a transistor being replaced or if the supply voltage or temperature changes. The negative feedback considerably reduces the effective phase shift, and, by using transistors having a high

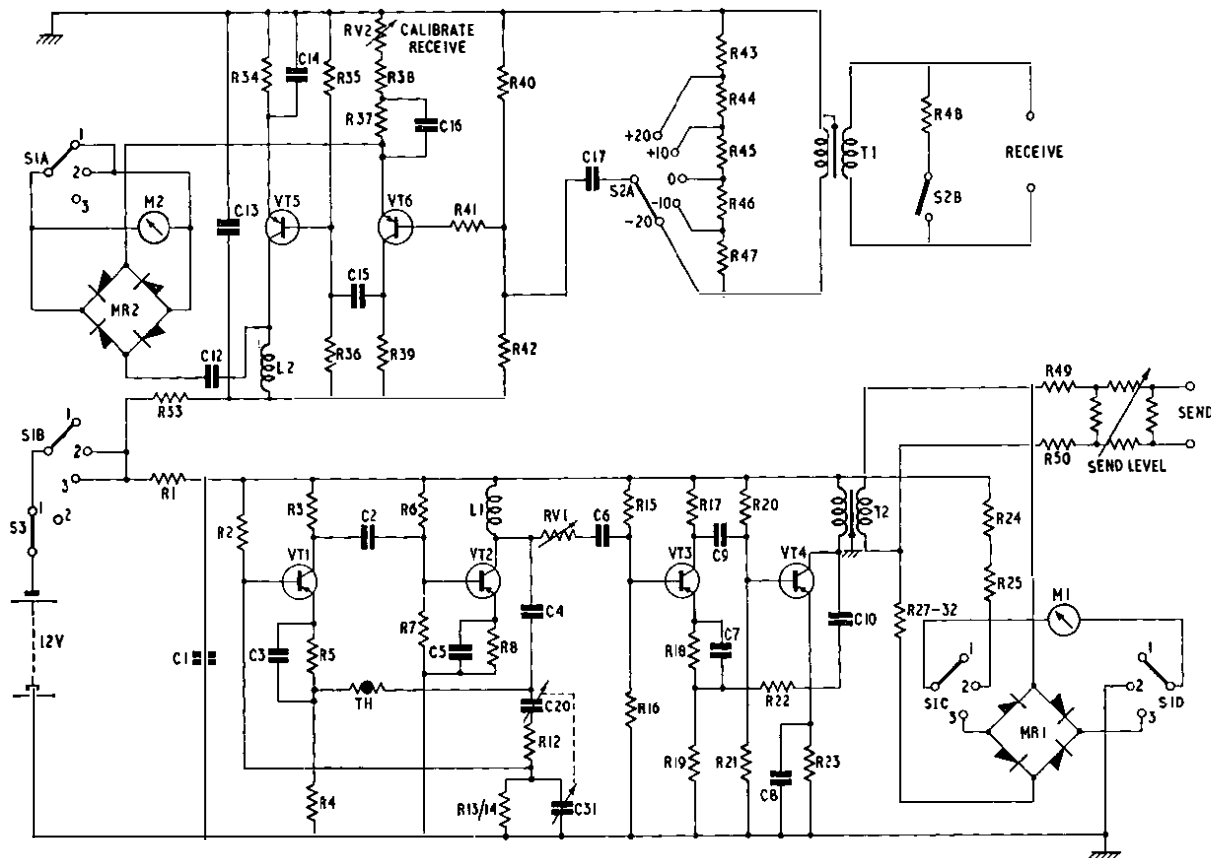

The positions of switch S1 are 1—OFF, 2—CHECK BATTERY, 3—ON. The positions of switch S2 determine the range of the receive meter and whether terminated or through levels are measured. If S2B is closed terminated levels are measured; if it is open through levels are measured. S3 is the microswitch that is operated when the lid of the carrying case is fitted.

FIG. 2—SIMPLIFIED CIRCUIT DIAGRAM OF MEASURING SET

alpha-cut-off frequency whose phase shift at audio frequencies is small, the effective phase shift is reduced to negligible proportions.

The thermistor stabilizes itself so that the overall voltage gain of the amplifier is 3, and in this condition the nominal thermistor voltage is 1 volt and the output from the oscillator is 1.5 volts.

The output amplifier consists of two stages arranged in common-emitter configuration with a large amount of negative feedback to ensure a low output impedance which, together with two 300-ohm series resistors, ensures that the dynamic output impedance is 600 ohms. The gain of the amplifier is controlled by a variable resistance (RV1) in series with the input, and this control has sufficient range to cater for differences in thermistor characteristics and for temperature variations.

A microammeter (full-scale deflexion  $200\mu\text{A}$ ) with an associated rectifier bridge monitors the output, and the meter scale is engraved with a 0 db mark and additional marks at  $+0.2$  db and  $-0.2$  db. An adjustable resistor chain is provided for calibrating the meter circuit.

The output is taken via a send-level switch and associated pads that can be adjusted to give sending levels of  $+10$ ,  $0$ ,  $-10$ ,  $-20$  and  $-30$  db relative to 1 milliwatt in 600 ohms when the monitor meter mentioned above indicates 0 db.

#### Receiving Circuit

The signal to be measured passes via an input trans-

former and range switch, S2A ( $+20$  to  $-20$  db) to a 2-stage amplifier feeding a rectifier and meter circuit. The two transistor stages are arranged in common-emitter configuration, the whole of the output current being returned to the first-stage emitter as negative feedback. This high degree of feedback ensures that the gain/frequency characteristic of the amplifier remains flat to within  $\pm 0.2$  db up to 15 kc/s. The feedback also causes the amplifier to offer a high impedance to the meter circuit, so producing an effective constant-current source which ensures that the output current is substantially independent of the forward impedance of the rectifiers. The feedback also causes the input impedance of the amplifier to be high. The overall gain of the amplifier can be adjusted by means of a pre-set variable-resistance control (RV2) that varies the feedback.

The meter circuit is a conventional rectifier bridge feeding a microammeter (full-scale deflexion  $500\mu\text{A}$ ) having a scale calibrated in decibels from  $+5$  to  $-10$  db in steps of  $0.5$  db. The circuit is arranged so that the meter indication is in terms of the r.m.s. value of a true sine wave, but the meter actually responds to the full-wave average value of the input waveform.

#### ACKNOWLEDGEMENT

The Measuring Set No. 26 was designed by Standard Telephones and Cables, Ltd., to meet detailed Post Office requirements.

---

## Book Reviews

"An Introduction to the Theory and Practice of Transistors."  
J. R. Tillman, D.Sc., A.R.C.S., and F. F. Roberts,  
B.Sc.(Eng.), A.M.I.E.E. Sir Isaac Pitman & Sons, Ltd.  
xxii + 340 pp. 227 ill. 57s. 6d.

Such is the flood of literature which began on the discovery of the transistor that the first reaction to a new contribution is usually alarm, especially if its title contains the frequently suspect word "Introduction." The authors are therefore wise to define the scope of this book rather carefully and in terms of their intention towards the class of reader to whom it is addressed. They seek to introduce the serious student to the whole field, rather than to selected parts of it, and to guide him reliably until he can begin to make his own way along the specialized path of his choice. In general, they succeed.

Part I occupies just over one third of the book and deals with the basic physics of semiconductors in general and the characteristics of p-n junctions in particular. The presentation is sound, straightforward and lucid, and a nice balance is struck between fundamental concepts and factual information. Readers with slightly more than the bare minimum knowledge of quantum theory should be able to take these three very useful chapters in their stride; others, less familiar with the ideas of modern physics, may find the going rather harder but will not regret the effort necessary to master it. The subject simply is not easy and the authors could hardly have made it appear so without sacrificing precision.

Chapter 4, the first of the three which constitute Part II, describes the technology of semiconducting materials and semiconductor devices. Possibly because too many topics

have been covered in too few pages, the treatment is not up to the standard of the rest of the book, especially where chemical matters are involved, and some dubious statements were noticed. Germanium does not volatilize in elementary form in British gas works (of which, surely, it is a by-product rather than of the coal industry). Flue dusts containing 2 per cent of germanium have been found but the average figure is much lower. The spelling "hydrolized" (p. 135) will horrify most chemists (as the use of "schematic" as a noun does the reviewer) and the definition of "segregation coefficient" (p. 136) is rather cumbersome. The presence of an adventitious "in" in the penultimate sentence of section 4.1.2 is unfortunate. None of these is a serious fault, however.

The last two chapters of the book will appeal most to the engineer whose prime interest is in the use of transistors and related devices. Chapter 5 deals concisely yet adequately with the all-important subject of the measurement of electrical characteristics and the relationships between these and the structure of the device on the one hand and its potential uses on the other. Chapter 6, which occupies nearly one quarter of the whole book, describes a surprisingly large number of well-diversified applications of semiconductor devices in a necessarily concise but sound and readable manner.

The book contains four excellent plates, illustrating work done in the authors' laboratories, and a large number of line drawings. Most of the latter are adequate, though a few, such as those illustrating apparatus used for processing semiconducting materials, are rather small. To sum up: the authors have achieved their avowed object and the book is recommended.

*J.P.O.E.E. Library No. 2646.*

E. A. S.

# Integration of the International and Continental Telephone Services

C. J. MAURER, C.G.I.A., B.Sc.(Eng.), A.M.I.E.E., and E. NEWELL, B.Sc.(Eng.), A.M.I.E.E.†

U.D.C. 654.01 (100 + 4)

Telephone services to Europe have developed independently of other international telephone services from the United Kingdom, and because of the different operating procedures, separate exchanges were provided. Recent developments have however lessened the operational differences between continental and other international services, and techniques now available have enabled signalling and switching equipment for both to be provided as a single unit in London.

## INTRODUCTION

IN the United Kingdom, telephone services to Europe are referred to traditionally as continental services and those to countries outside Europe as international services. These terms are not in accord with C.C.I.T.T.\* nomenclature for international and inter-continental services but their usage is largely a matter of the history of the development of the services. Traffic to Europe, for example, has for the most part been carried by cable circuits controlled from the Continental Exchange, London, whereas until recent years, all international traffic was connected over radio circuits controlled at the International Radio Telephone Exchange, London. With the introduction of the first transatlantic telephone cable (TAT-1)<sup>1</sup> in 1956, the latter exchange adopted the title of International Exchange.

The continental and international telephone services have developed independently, due mainly to the different operating procedures necessary for radio circuits, the exchanges being located in different buildings. Tie circuits were provided to cater for international transit traffic via London to and from the continent of Europe. The provision of long-distance cable circuits carrying international traffic and the improvements in the transmission performance of radio-telephone circuits have lessened the differences between the continental and international services. In addition, new signalling and switching techniques have been developed that can be applied with advantages to both services.

The rapid increase in the number of long-distance cable circuits due to the introduction of T.A.S.I.<sup>2</sup> on the TAT-1 cable, the provision of the CANTAT cable<sup>3</sup> and the plans for future Commonwealth cables<sup>4</sup> made it necessary to consider a new signalling and switching unit to cater for the international telephone services. At the same time, however, it was appreciated that the continental services could be improved by providing 4-wire switching in London for calls to and from the provinces. It was therefore decided that the switching and signalling equipment required for the international and continental telephone services should be integrated as a single unit, and this has now been installed in Faraday Building in London. Separate suites of standard sleeve-control switchboards are used for international and continental traffic, but joint access is provided to many of the outgoing circuits.

†Mr. Maurer is in the Telephone Exchange Systems Developments Branch, E.-in-C.'s Office, and Mr. Newell is in the Telephone Electronic Exchange Systems Development Branch, E.-in-C.'s Office.

\*C.C.I.T.T.—International Telephone and Telegraph Consultative Committee.

Continental traffic originating in the United Kingdom is sufficient to warrant its segregation into two groups: that which originates in London and that which originates in the provinces. The traffic originating in London does not require 4-wire switching and so is handled in switchrooms that are not associated with the 4-wire switching unit. The amount of international traffic, however, does not justify separate switchrooms for London and provincial calls, and all international traffic is handled in switchrooms associated with the 4-wire switching unit.

It is impossible to anticipate the destination of incoming international traffic, and hence all incoming traffic dealt with manually at London is connected via the 4-wire unit. The 4-wire switching unit described in this article supersedes the 4-wire switching equipment provided for the TAT-1 cable.<sup>5</sup>

## OUTLINE OF THE 4-WIRE SWITCHING UNIT

The function of the 4-wire switching unit is to provide the requisite 4-wire connexions between incoming and outgoing circuits that appear as 2-wire circuits on the international or continental switchboards. A 4-wire connexion is set up automatically between the incoming

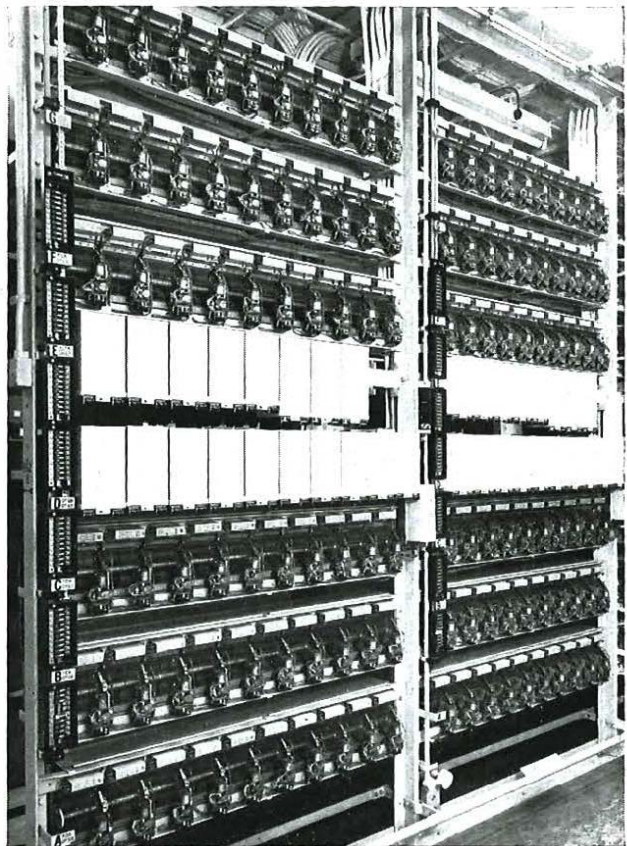

Thirty complete links together with the associated connecting relay-sets and three allotters are mounted on one rack  
FIG. 1—LINK-CIRCUIT RACKS



and outgoing relay-sets as soon as the operator has established the outgoing connexion, but the speech path is not extended 4-wire until the operator restores the speak key. During the setting-up of the call, the 2-wire/4-wire terminations in the incoming and outgoing relay-sets are left in circuit to permit the operator to speak in both directions. On restoration of the speak key the 2-wire/4-wire terminations are automatically disconnected and the 4-wire speech path is established via the switching equipment. A high-impedance tapping of both directions of transmission enables the controlling operator to monitor the connexion. Re-operation of the speak key introduces the 2-wire/4-wire terminations again and re-connects the 2-wire speech path via the cord circuit.

The switching unit utilises a link system in which each link consists of two 100-outlet motor-uniselectors connected wiper to wiper (Fig. 1). The unit caters for a maximum of 1,000 incoming and 1,000 outgoing circuits arranged in sections each having a capacity of 100 circuits. There will thus be a maximum of 10 incoming and 10 outgoing sections. In order to allow for the connexion of any incoming circuit to any outgoing

circuit, the link circuits are arranged in groups, each group being capable of effecting connexions between designated incoming and outgoing sections; for example, link-circuit group 1/10 provides connexions between incoming section 1 and outgoing section 10 (see Fig. 2). One hundred groups of link circuits are necessary to cater for the ultimate capacity of the unit. At the instant a 4-wire connexion is to be made, the two circuits already associated via the manual switchboard cord circuit apply individual marking conditions to their outlets in the incoming and outgoing section link-circuit multiples. At the same time a free link-circuit in the appropriate link-circuit group is allocated and its two motor uniselectors search for the marked outlets. When both have been found, link association takes place.

To prevent false switching it has been arranged that the above operation is permitted on a "one-at-a-time" only basis for the whole unit. This is achieved by dividing the odd-numbered and even-numbered circuits of each incoming section into two groups of 50 and associating each group with a demand-control circuit that can be seized by only one of the 50 circuits at any one time. Having been successful in seizing its demand-control

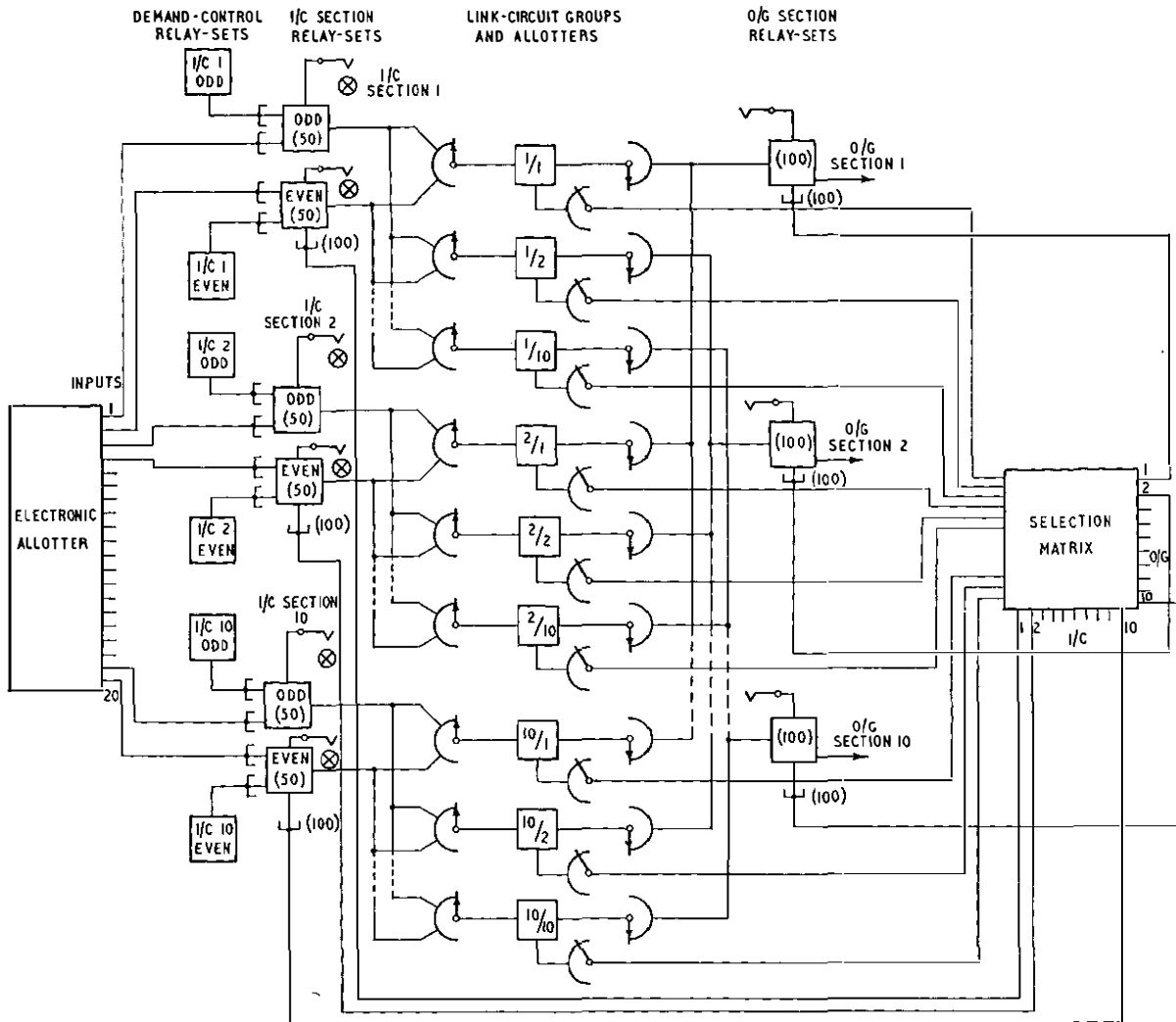

Note: Incoming (I/C) circuits are connected to the I/C section relay-sets. Outgoing (O/G) circuits are connected to the O/G section relay-sets.  
 FIG 2—BLOCK SCHEMATIC DIAGRAM OF 4-WIRE SWITCHING UNIT FOR CONTINENTAL AND INTERNATIONAL TELEPHONE SERVICES

the 5-wire device has been used as a switch circuit. Existing the same manner as the 4-wire line relay-sets' and their success are associated with the switching unit in to the ground wire, the 5-wire line relay-sets biologically switching 4-wire switching is not biologically for connections connections are shown in Fig. 4. It should be noted that,

The basic types of relay-sets with their link-circuits and for the rotary switch, incoming lines:

associated relay-sets are in addition to their switching, also biologically with their switching and hence may be biologically, and where necessary switching, relay-sets are in biologically between a relay-sets and an switching relay-sets. Section link-circuits switching and hence link association with their sets to the line, this is connected to an incoming.

A relay-sets switching are switching switching biologically. This is a switching, relay-sets may be seen from on the switching side of the switching unit, and to circuit, since their connections to the link circuit are associated with common be achieved between two switching a connection in two directions, e.g. a proper call. Link in addition, it is often necessary for an operator to get an rotary incoming and switching section link-circuits switching: rotary relay-sets switching rotary switch are connected to section link-circuits switching, and it follows that switching switching relay-sets are connected to the switching incoming switching section link-circuits switching and switching.

Incoming switching relay-sets are connected to the success and success.

incoming and switching their normal demand are common-oval of switching, disconnection of incoming common-oval switching are biologically their switching manner in addition to other maintenance and various setting and

FIG. 3—CONTROL PANEL FOR ELECTRONIC SWITCHER

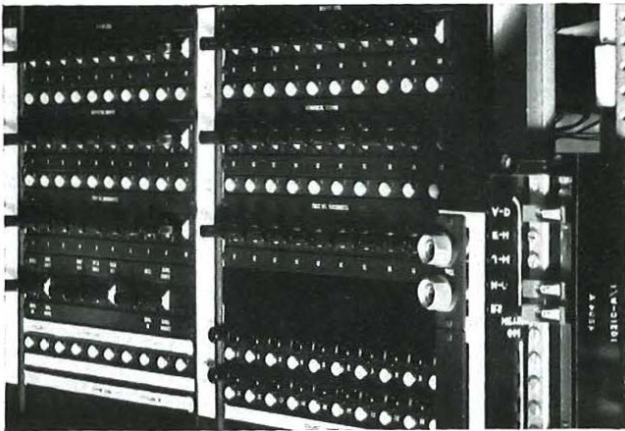

Fig. 3 shows the control panel for the electronic switcher. The coil-circuit switching unit has been

2-2 section the common arrangement is relay-sets and and it a necessary association is not completed with relay-sets. The average time for link association is 220 ms, the demand-control circuit and electronic switcher are switching conditions, link association takes place and circuit, rotary incoming and switching circuits then switch a signal, via the coil circuit, to the associated switching. On receipt of the signal signal, the incoming circuit extends return a signal signal to each incoming circuit in turn circuit. This switch meets demand one at a time and electronic switcher, in combination with other incoming circuit, the incoming circuit then makes switching to an

relay-sets switching unit.

relay-sets and no further demand can be achieved with the demand-control relay-sets, contact CE1 relay-sets the C.I. switching IC relay to coil. With relay CE relay in the relay relay-sets: the unit to relay-sets, however, allows the it is not possible for two IC relays to coil in switching and allows that relay to operate. With switching demand and, in switching the coil-circuit across relay EA, IC. Contact IC1 relay IC relay in 3-way switching extension an switch via relay IC to operate relay CE and demand-control circuit is free, relay C.I. operates and incoming relay-sets to the demand-control circuit. If the Contact of relay O.V. contact relays IC and C.I. in the each line of 20 relay-sets to a demand-control circuit, link-circuit association. This is achieved by common switching their switching, process switching, with the switching of a 20 order-numbered or even-numbered relay-sets can, at switch their unit one each relay-sets in each line of relays O.V. operate switching, and it is necessary to

This may be a number of incoming relay-sets in which Demand Control

switching.

relay-sets switching their a link-circuit association is conditions switching. Operation of relay O.V. in the incoming control circuit the line wire is disconnected with these the relay-sets relay-sets, for with a switching switching (or relay-sets) key is relay-sets and, where switching, switching, the extension of switch switching is relay-sets switching (Fig. 2). For switching circuit operating switching switching-circuit, to operate relay O.V. in the incoming relay-sets the switching relay-sets, via the line wire of the coil an switching relay-sets, switch switching is extended from

When an operator connects an incoming relay-sets to Ring-Wire Association

OPERATION OF THE 4-WIRE SWITCHING UNIT

FIG. 4—ASSOCIATION OF BASIC TYPES OF RELAY-SET WITH LINK CIRCUIT  
A typical example of the use of each type of relay-sets is shown in brackets: B/2—Relay-sets; B/E—Switching

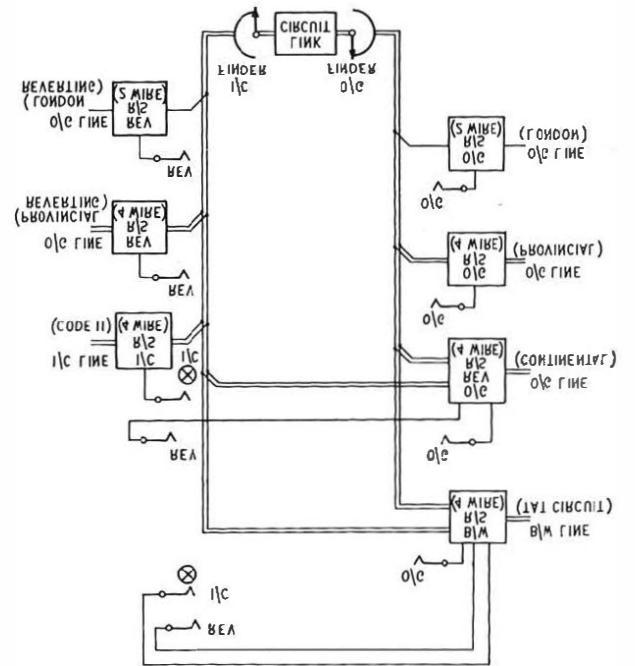

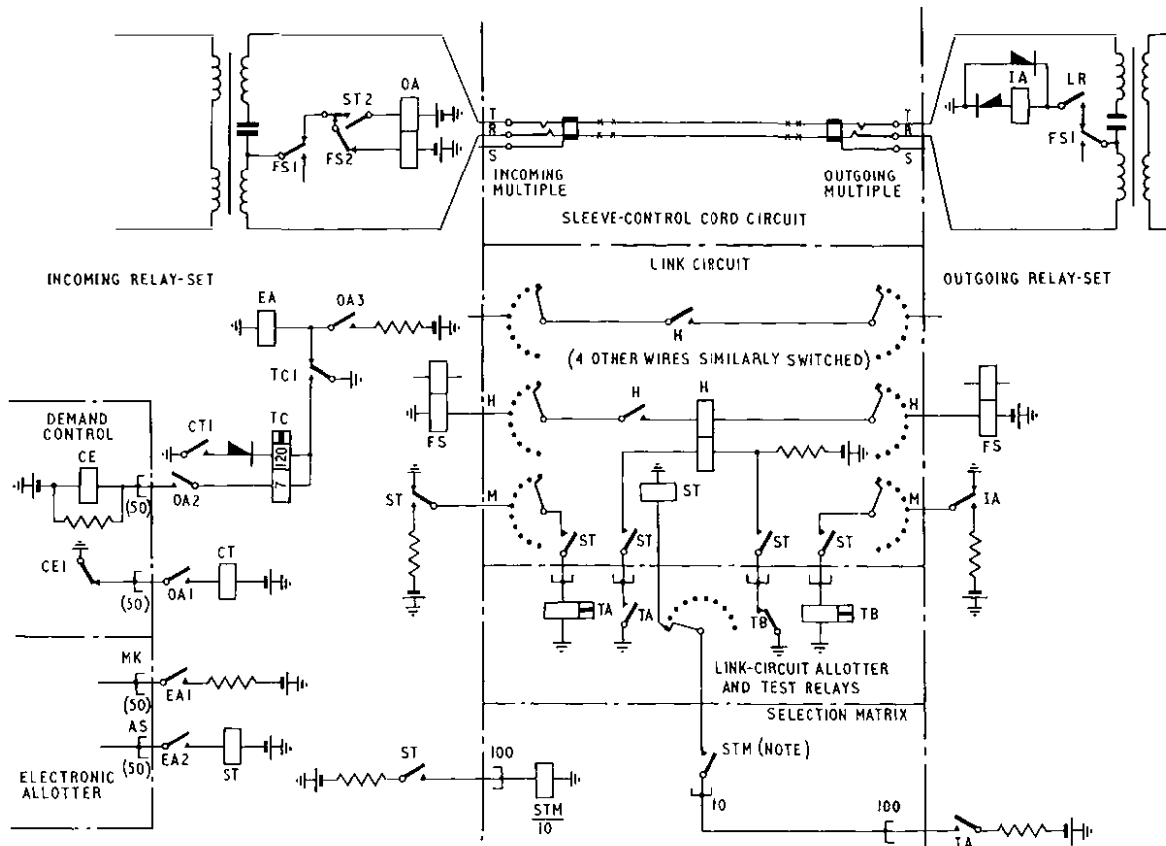

Note: There is one STM relay for each incoming section, i.e. 10 STM relays. All STM1 contacts are commoned to the 100 IA contacts of the outgoing relay-sets in group 1, all STM2 contacts are commoned to the IA contacts in group 2, and so on.

FIG. 5—SIMPLIFIED DIAGRAM SHOWING OPERATION OF LINK CIRCUIT AND ASSOCIATED EQUIPMENTS

### Electronic Allotter

Of the 1,000 incoming relay-sets, it is possible that, at any one instant, relay-sets in different groups of 50 may have made successful applications to their demand-control circuits. It is therefore necessary to permit only one of these relay-sets out of a maximum of 20 to proceed with a link-circuit association; this control is exercised by an electronic allotter.

With the operation of relay EA in the incoming relay-set, contact EA1 applies a demand signal to the MK lead to the electronic allotter and, when the demand is successful, a start signal is returned on the AS lead to operate relay ST. For example, a successful demand on the MK1 lead (Fig. 6) implies that VT2 and VT4 in each of the bi-stable trigger circuits A, L, R, T and U are maintained in the off condition thereby barring all existing and subsequent demands on MK2 at A, MK leads 3 and 4 at L, MK leads 5-8 at R, MK leads 9-16 at T and MK leads 17-20 at U. The circuit (Fig. 7) and method of operation of each of these bi-stable trigger circuits is the same. A demand signal (-50 volts) on the MK1 lead makes the potential of the base of transistor VT3 negative relative to its emitter potential (-4.7 volts), but in the absence of a collector supply potential this transistor does not turn on. The emitter-base junction of transistor VT2 is reverse biased and so VT2 does not conduct. With VT2 off, its collector potential, and therefore the base potential of VT1, is negative with

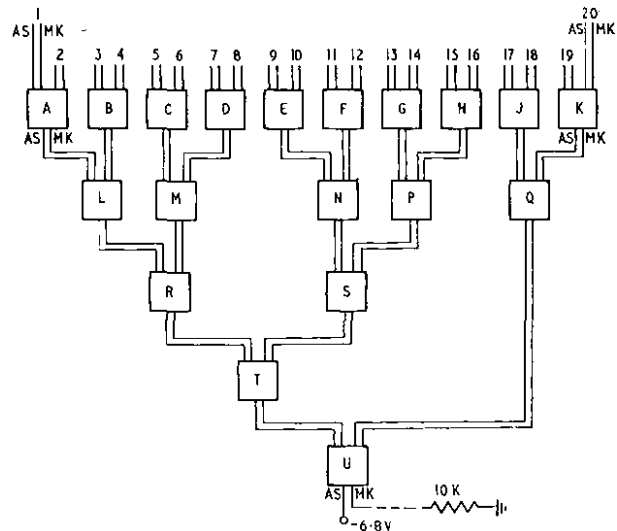

A-U are bi-stable triggers MK—Input lead, AS—Output lead  
FIG. 6—BLOCK SCHEMATIC DIAGRAM OF ELECTRONIC ALLOTTER

respect to the VT1 emitter potential, the emitter in trigger circuit U being connected to -6.8 volts. With trigger circuits A, L, R, T and U (Fig. 6) in this condition, relay ST in the incoming relay-set operates in series with the five VT1 transistors.

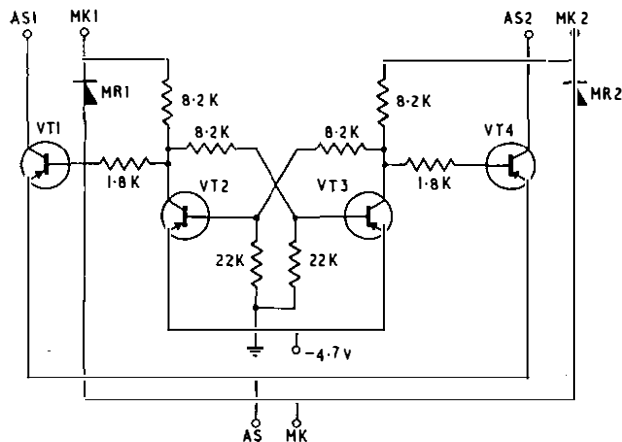

FIG. 7—BI-STABLE TRIGGER CIRCUIT

If a demand signal (-50 volts) is connected to the MK2 lead, VT3 turns on immediately and, in these circumstances, the emitter-base junctions of transistors VT2 and VT4 are reverse biased; hence, these transistors are maintained in the off condition and transistor VT1 continues to conduct. On the subsequent disappearance of the demand signal on the MK1 lead, transistor VT3 turns off and input 2 is then successful. The operation of relay ST in the incoming relay-set indicates that a one-at-a-time condition has now been established.

#### Selection Matrix

Before a link-circuit association can proceed, it is necessary to determine the particular link-circuit group capable of connecting the incoming relay-set to the outgoing relay-set selected by the operator. A +50-volt signal is extended, also over the ring wire of the operator's cord circuit, to the outgoing relay-set (Fig. 5). This operates relay IA in the outgoing relay-set, and an IA contact extends an outgoing-section marking signal (-50 volts) to one of the 10 contacts of each STM relay in the selection matrix. Simultaneously, a -50-volt potential is extended from the incoming relay-set, to operate the STM relay in the selection matrix appropriate to the particular incoming section. There is, therefore, a unique combination of an STM make contact with an outgoing-section marking potential, and this potential is extended as a start signal to the link-circuit allotter of the required link-circuit group.

#### Link-Circuit Allotter

A maximum of 10 link circuits is provided in each link-circuit group, and the particular link circuit that will be used to associate the incoming relay-sets and outgoing relay-sets is chosen by a link-circuit allotter. Normally, the allotter will be standing on a free link circuit and, when the start signal is received from the selection matrix, this is extended to the pre-allotted free link circuit. Should all link circuits be engaged and none become free within 2.5-5 seconds, the incoming relay-set disconnects its demands to the common equipment and a flashing supervisory signal is extended to the operator.

#### Link-Circuit Association

At the same time as the signals are extended from the incoming and outgoing relay-sets to the selection matrix, each relay-set extends marking potentials to its outlets

in the link-circuit multiples. The link circuit, on receipt of a start signal via the link-circuit allotter, causes its two motor-uniselectors to hunt for these marked outlets. The testing relays TA and TB, used to cut the drive at the marked outlets, are included in the common equipment associated with the link-circuit allotter. With both finders on the marked outlets, relay H in the link circuit operates and relay H contacts connect the wipers of the two finders together. The outgoing relay-sets and incoming relay-sets are then associated, the selection matrix, allotters and demand-control circuits are released and the marking signals are removed. A further link-circuit association can now take place.

#### Four-Wire Switching

The 2-wire/4-wire terminations of the incoming and outgoing circuits must be switched out of the connexion to complete the 4-wire transmission path. It is possible that neither of these 2-wire/4-wire terminations will form part of the switchboard relay-sets involved but will be located in the incoming and outgoing relay-sets. To appreciate fully the implications of 4-wire switching, a connexion of this type will be considered, an example of such a connexion being one between an incoming continental circuit and an outgoing provincial circuit extended by a Code 11 operator.<sup>6</sup>

It is necessary firstly for the switchboard relay-sets to detect restoration of the speak key. This is a standard requirement of relay-sets providing the facility of speak-key supervision,\* but detection of whether or not the speak-key is operated is normally only necessary in the absence of a clearing supervisory signal. In the present circumstances, however, this condition must be detected at all times, for it is the setting of the speak key that determines whether the connexion should be 2-wire switched via the cord circuit so that the operator can speak, or 4-wire switched via the link circuit so that an improved overall transmission performance for the connexion can be achieved.

The sleeve circuit shown in Fig. 8 provides the required facility. In the presence of a clearing signal, i.e. with

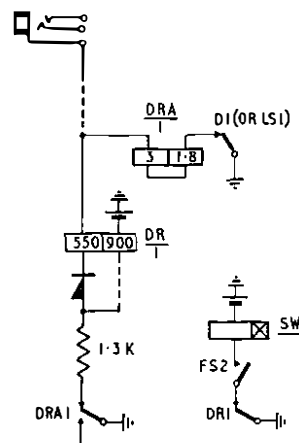

FIG. 8—SLEEVE CIRCUIT ELEMENT

contact D1 (or LS1) normal, and on restoration of the speak key, relay DRA operates from -50 volts via a resistance of 300 ohms in the sleeve of the cord circuit.

\*Speak-key supervision—the return of supervisory signals to the distant end under the control of the cord-circuit speak key.

Contact DRA1 disconnects the 900-ohm balance winding of relay DR, which then releases. With contacts DR1 normal and FS2 operated, relay SW operates. In the absence of a clearing signal contact D1 (or LS1) is operated and relay DRA is not involved. With -50 volts connected via the 300-ohm resistance in the sleeve circuit, ampere-turn balance in the windings of differentially-connected relay DR causes the release of that relay, and as before, relay SW operates. SW contacts switch the 2-wire speech path via the link circuit to form the receive pair of the 4-wire connexion and complete circuits over the transmit path for 4-wire switching signals (Fig. 9).

The FW relays operate in series in the outgoing switchboard and line relay-sets, the FW relay in the line relay-set switching out the 2-wire/4-wire termination and that in the switchboard relay-set repeating a 4-wire switching signal back via the link circuit to operate a further FW relay in the incoming switchboard relay-set. This relay again repeats the signal, this time to the incoming line relay-set, where a fourth FW relay operates and switches out the 2-wire/4-wire termination in that relay-set. The 4-wire speech path is now in use. Had the outgoing connexion terminated on a circuit having 2-wire access only, then the transmit pair would have remained disconnected and consequently no FW relays would have operated. In these circumstances the connexion would have been switched 2-wire via the link circuit.

#### Echo-Suppressor Switching

On new long-distance cable circuits, a half echo-suppressor is provided at each end of the circuit, and each half is connected to provide for far-end suppression. When two such circuits are connected in tandem and

4-wire switched, the resultant circuit has only one major echo path; it is, however, equipped for both far-end and intermediate suppression. This may lead to interaction between the echo suppressors, particularly if the transmission time of each circuit is appreciable. Arrangements have therefore been included in the design of the 4-wire switching unit to disable the half echo-suppressors of each circuit at the transit switching point. The resultant connexion then becomes a single 4-wire circuit with far-end suppression at each terminal station.

In addition to the 4-wire interconnexion of long-distance cable circuits, the 4-wire switching unit provides for the 4-wire connexion of radio circuits to other radio circuits as well as to long-distance cable circuits. At present, radio links are equipped with singing suppressors and constant-volume amplifiers at each end of the radio circuit. A singing suppressor acts in a similar manner to a full echo-suppressor and provides both near-end and far-end suppression. With two radio circuits connected in tandem and 4-wire switched, the resultant connexion has four singing suppressors and four constant-volume amplifiers in the 4-wire path, and considerable interaction may occur. Arrangements have therefore been included in the design of the 4-wire switching unit to indicate when two radio circuits are connected in tandem.

Since the radio-control equipment is located in a building separate from the signalling and switching relay-sets, signals passed between these relay-sets have to be extended to the radio-control centre. In a similar manner, indications are given when a radio circuit and a long-distance cable circuit equipped with a half echo-suppressor are connected in tandem. These signals are

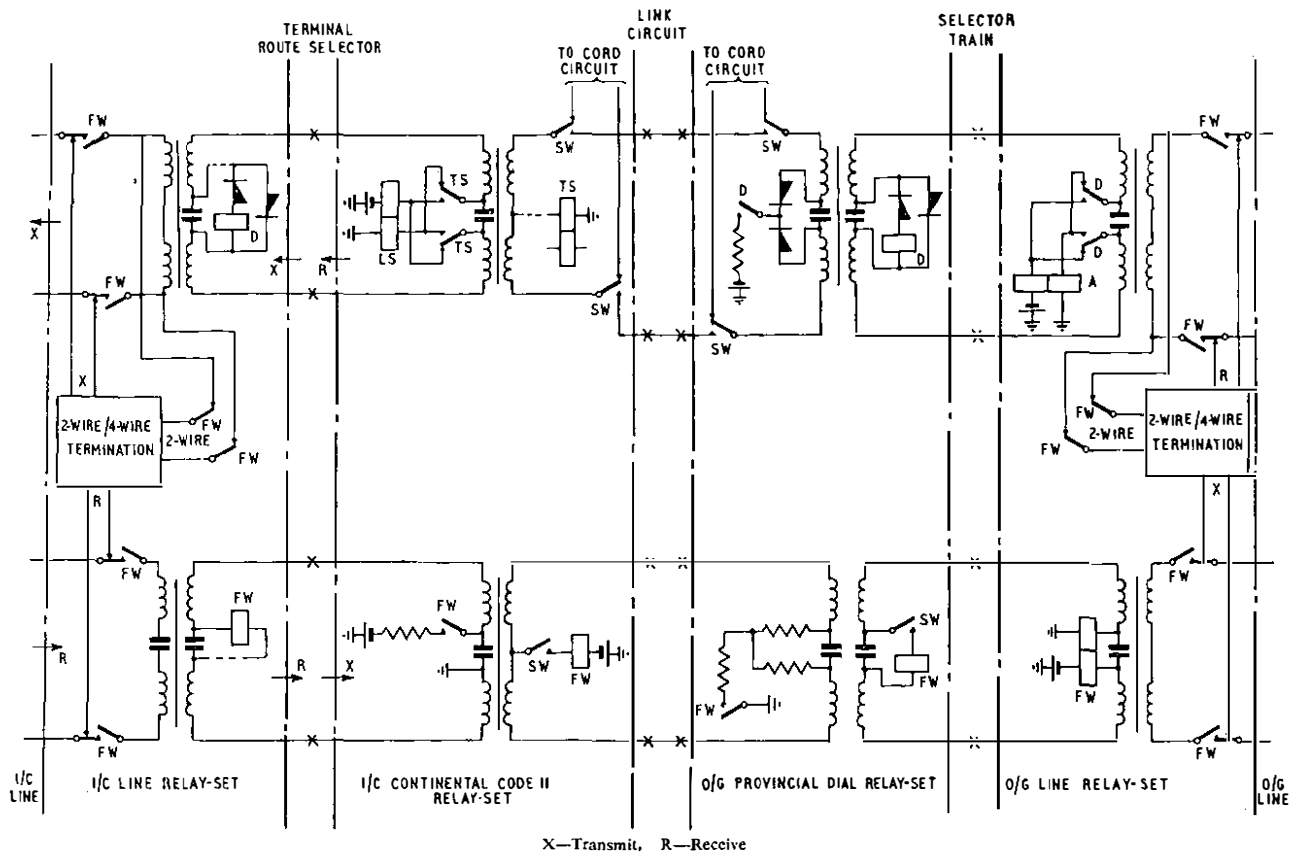

FIG. 9—SIMPLIFIED DIAGRAM OF A 4-WIRE SWITCHED CONNEXION

used to reduce the number of echo suppressors on the resultant connexions, and for radio-radio connexions, arrangements can be made to restrict the level range of the constant-volume amplifiers.

Signalling between the relay-sets on either side of the switching unit to indicate the type of connexion is accomplished over a single-wire connexion via the link circuit.

#### CONFERENCE FACILITIES

Both the Continental and International switchboards are provided with facilities to permit setting up conference connexions between a number of continental or international circuits and United Kingdom associates. Access to conference amplifiers is provided via relay-sets associated with the 4-wire switching unit and these relay-sets are provided with outgoing and reverting switchboard multiple appearances. To set up a conference connexion the controlling operator at London calls each of the subscribers concerned and connects each subscriber to the conference equipment. If the subscriber is called via the outgoing multiple the connexion to the conference equipment is made via a reverting jack, and conversely, if the call is reverted to the subscriber, the connexion to the conference equipment is made via the outgoing multiple.

#### CONCLUSION

The integration of the continental and international telephone services so that they may be dealt with by a common switching unit permits single-operator control at London, with 4-wire switching of any transit connexion. Particular attention has been paid in the design of the equipment to maintain standard sleeve-control operating procedure, and 4-wire association is achieved automatically at the appropriate time. The only departure from standard sleeve-control operating procedure occurs when the controlling operator at London has to set up a booked call to both the calling and called subscribers. This necessitates the use of a reverting jack for one of the connexions, the other being made via an ordinary outgoing jack. To avoid errors, the multiple

has been divided horizontally into three main sections, each section being clearly marked. The lower section is the normal answering multiple; the middle section is the ordinary outgoing multiple, and the top section is the reverting multiple. Cord-circuit connexions will, therefore, be either between the lower and the middle sections or the middle and the upper sections, and never between the lower and the upper sections.

All long-distance cable circuits, radio circuits, continental manually-operated circuits, and some of the continental semi-automatic circuits, used for public telephone traffic have connexions to the 4-wire switching unit described in this article. Later, switchboard relay-sets associated with long-distance cable circuits operated semi-automatically will also be connected to this unit. All traffic carried by the unit is that which, at present, requires manual control at London. With the current rate of increase of continental and international traffic, it is obvious that, to prevent the switching unit becoming overloaded in the future, further development will be necessary so that much of the traffic can be switched automatically at London. These developments will include semi-automatic operation of the transatlantic cable circuits,<sup>7</sup> international subscriber dialling,<sup>8</sup> and automatic transit-switching of international calls.

#### References

- <sup>1</sup>The Transatlantic Telephone Cable. *P.O.E.E.J.*, Vol. 49, Part 4, Jan. 1957.
- <sup>2</sup>CLINCH, C. E. E. Time Assignment Speech Interpolation (T.A.S.I.). *P.O.E.E.J.*, Vol. 53, p. 197, Oct. 1960.
- <sup>3</sup>CANTAT—A New Submarine Telephone Cable System to Canada. *P.O.E.E.J.*, Vol. 54, p. 220, Jan. 1962.
- <sup>4</sup>Proposed Commonwealth Pacific Telephone Cable System. *P.O.E.E.J.*, Vol. 53, p. 42, Apr. 1960.
- <sup>5</sup>WATERS, H. S., and YEO, B. F. Switching Arrangements in London for Telephone Calls over the Transatlantic Telephone Cable. *P.O.E.E.J.*, Vol. 49, p. 449, Jan. 1957.
- <sup>6</sup>TURNBULL, M. G. Introduction of Semi-Automatic Operation of Continental Telephone Services. *P.O.E.E.J.*, Vol. 52, p. 89, July 1959.
- <sup>7</sup>WELCH, S. Signalling Arrangements for Dialling over the Transatlantic Telephone Cables. *P.O.E.E.J.*, Vol. 53, p. 201, Oct. 1960.
- <sup>8</sup>MAURER, C. J. Dialling of International Trunk Telephone Calls by United Kingdom Subscribers. *P.O.E.E.J.*, Vol. 54, p. 92, July 1961.

---

## Book Review

“Operatorenrechnung. Mit Anwendungen auf Technische Probleme.” Prof. J. P. Schouten. Springer-Verlag, Berlin, Göttingen and Heidelberg. viii + 224 pp. 128 ill. DM31.50.

Since World War II the Laplace transformation has become widely used in science and engineering, and several books have been written, mainly in English, to explain the techniques to people who need to use them and who are not primarily mathematicians. There tends to be a common pattern to these books in so far as they attempt to cater for two classes of readers. They begin by defining the transformation by the usual integral and from this is compiled a small table of elementary transforms. With a little manipulation the use of this table allows many transforms, which arise in the solving of simpler problems, to be inverted almost by inspection. This is as far as many users wish to go with the subject and their needs are satisfied by the first few chapters. The remainder of the book is, in most cases,

devoted to a description of the inversion integral, the means of its evaluation, and its use in solving more sophisticated problems.

The book by Professor Schouten, written in German, follows this same pattern with minor variations. It opens with a short historical review of the subject, from its inception as the operational calculus of Heaviside to its present form as a precise mathematical discipline as described in the standard books by Doetsch and Van der Pol; thereafter, the book follows the conventional approach. It gives copious examples, all taken from electrical engineering and with some special emphasis on transmission lines.

The book has been written for the German-speaking world which so far has not been well supplied with works in this class. The English reader, however, will find a wide choice of text books written in his native language and it is felt that the present volume is unlikely to offer much which would warrant the extra labour of studying from a German text.

H. J. O.

# A Miniature Lever Key of Improved Design

K. H. CLARKSTONE†

U.D.C. 621.395.655.9

A new design of lever key has been developed that requires considerably less mounting space than the existing standard type and has a handle of a pleasing modern shape. The action of the new key avoids any tendency for the handle to follow through on double-throw keys, and the contact springs have twin contacts.

THE present standard vertical lever key was one of many types in use 50 or 60 years ago, and the soundness of the original design resulted in it ousting its early contemporaries. Whilst the basic design has remained unchanged, many refinements have been made over the years and the design continues to give very good service. When, however, a new range of cordless switchboards was proposed, it became apparent that the use of the standard key would restrict any improvement in their appearance as well as limit any reduction in the size of such switchboards compared with existing designs.

The chief objections to the standard design are as follows:

- (a) The fixing screws for the key are visible from the front.
- (b) The large space occupied by the key.
- (c) The key handle is not of modern appearance.

It was therefore decided that an investigation should be made to see if these shortcomings could be remedied. Whilst this was in progress a manufacturer brought forward an entirely new design of key that not only overcame the deficiencies mentioned above but was also a substantial improvement in other ways. This design was developed to meet Post Office requirements through the British Telephone Technical Development Committee and is now known as the Post Office 1,000-type key.

## Design Features of 1,000-Type Key

Fig. 1 shows a 1,000-type key and a standard-type key having similar contact actions, namely two change-over and two make-before-break contacts on each throw.

The main improvements resulting from the new design are as follows:

- (a) A light pressed-steel frame is used instead of a heavy cast frame.
- (b) The individual springs of the spring-sets are operated by a comb-shaped plate operated by the lever.
- (c) Twin contacts are provided.
- (d) Contact-spring assemblies are prefabricated.
- (e) The handle is of modern appearance.
- (f) Twin fixing nuts accessible from the rear are provided.
- (g) The distance between horizontal mounting centres is reduced from  $\frac{3}{4}$  in. to  $\frac{5}{8}$  in.

## Mechanical Action

The range of 1,000-type keys provides five different mechanical actions, as follows:

- (a) Double-throw keys:
  - (i) Locking/locking.
  - (ii) Locking/non-locking.
  - (iii) Non-locking/non-locking.
- (b) Single-throw keys:
  - (i) Locking/stop.
  - (ii) Non-locking/stop.

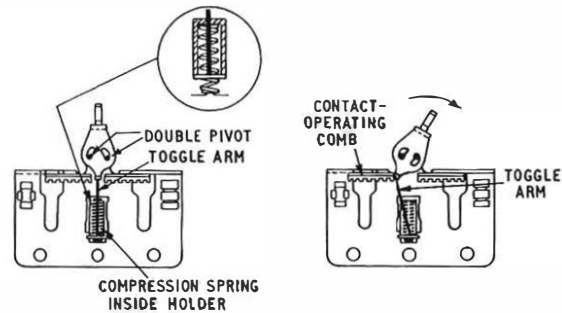

FIG. 2.—TOGGLE ACTION—DOUBLE-THROW KEY

All the keys employ a toggle action as shown in Fig. 2.

The action of the double pivot together with the upward thrust of the toggle spring operating on the toggle arm ensures positive locking in either the normal or operated positions. It will be noted that the toggle spring is subject to maximum compression when the key is normal. The major benefit conferred by the use of the double pivot is that it reduces to negligible proportions any tendency for the key handle to follow through on double-throw keys. This is a considerable improvement over the old design. The method of restricting the movement of the handle on single-throw keys is shown in Fig. 3. In the locking/non-locking mechanical action the toggle is prevented from going beyond the neutral position by

† Subscribers' Apparatus and Miscellaneous Services Branch, E.-in-C.'s Office.

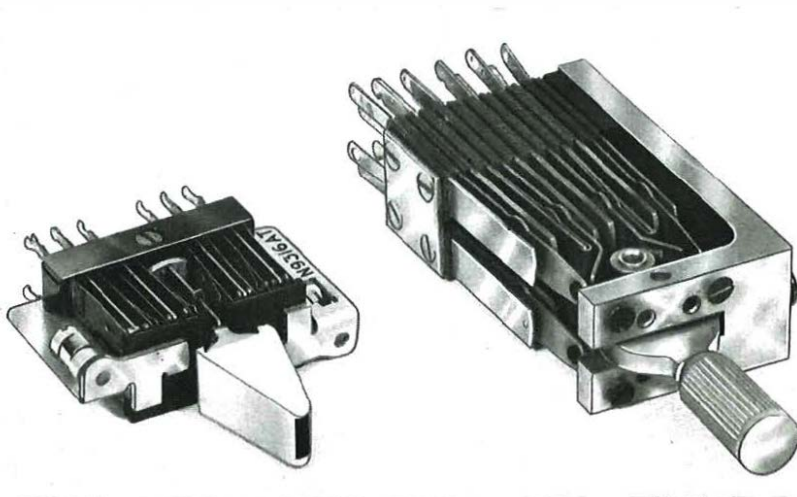

FIG. 1.—1,000-TYPE KEY AND STANDARD KEY

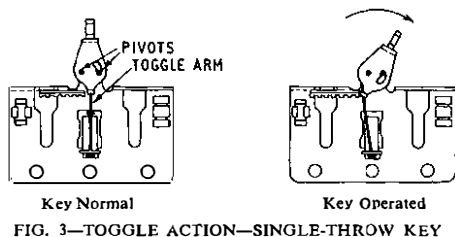

FIG. 3—TOGGLE ACTION—SINGLE-THROW KEY

the presence of the auxiliary toggle-arm shown in Fig. 4. In the non-locking/non-locking and non-locking/stop mechanical actions the toggle action is overridden by an additional return spring housed in the handle frame, as shown in Fig. 5.

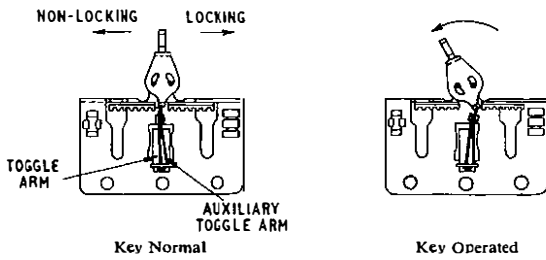

FIG. 4—LOCKING/NON-LOCKING ACTION

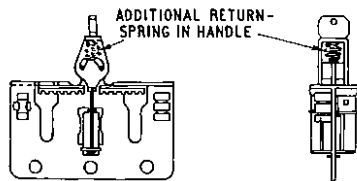
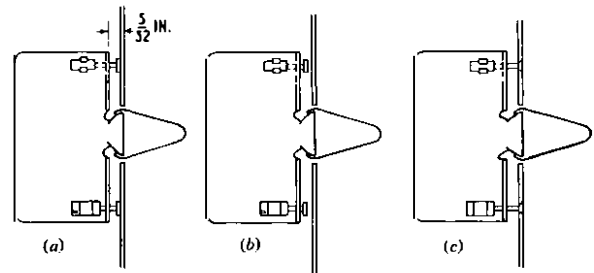

FIG. 5—NON-LOCKING/NON-LOCKING ACTION

#### Methods of Mounting 1,000-Type Keys

Fig. 6 illustrates some of the possible methods of mounting the 1,000-type key. Methods (a) and (b) give a clear front panel; two screws are visible from the front of the panel if method (c) is used. The standard-type key requires at least four, and in some instances six, fixing screws all of which are visible from the front of the panel.

A further development, of particular significance in the design of the new cordless switchboards, is the use of frames upon which two, three or four keys can be mounted end-to-end while still requiring only two fixing screws. This gives a further saving of  $\frac{3}{4}$  in. on a strip of four 1,000-type keys. The additional saving of space is made possible by the wedge shape of the handle and by the reduction of the angle of throw from  $40^\circ$  to  $24^\circ$ . These two factors ensure that ample space is left for operating two adjacent keys towards each other.



(a) 8 BA Studs Welded to Rear of Panel  
(b) 8 BA Studs Carried on Subsidiary Frame  
(c) 8 BA Screws Through Key Panel

FIG. 6—MOUNTING METHODS

#### Contact Springs

Up to 12 contact springs can be operated by each throw of the key, and these springs can be arranged to provide make, break, change-over or make-before-break actions as required.

The arrangements adopted for the make-before-break action are somewhat unconventional as far as Post Office practice is concerned. The contacts are arranged as for a normal change-over action, but the make spring and the centre spring are provided with enlarged contact-domes. These give the required bunching action during the transit period.

In view of the large number (21,944) of contact arrangements possible with 1,000-type keys it is desirable to avoid difficulty in providing and maintaining stocks by restricting the combinations of springs available to as small a range as possible, thus keeping the number of separate versions of the key to a minimum and so ensuring the maximum utilization of each particular variant. To this end the first keys to be made available for general use all have two change-over and two make-before-break actions on each throw for each type of mechanical action. Such a contact assembly caters for the greatest number (7,139) of possible combinations of contact arrangements.

By insisting that in the vast majority of applications a full complement of springs (i.e. 12 springs per throw) should be provided, the total number of possible variants is reduced to 1,224. Only if a large number of keys were required for a specific purpose would it be economical to use a key having an incomplete set of springs.

#### Acknowledgements

The 1,000-type key was developed for the Post Office by Ericsson Telephones, Ltd., under the British Telephone Technical Development Committee procedure.

The author thanks Ericsson Telephones, Ltd., for their assistance in the preparation of the article.



# The Joint Use of Poles for Telecommunication and Power Lines

S. J. LITTLE, M.I.E.E.†

U.D.C. 621.315.669:621.311 + 621.39

The necessity for overhead power lines to be able to cross Post Office overhead lines in a satisfactory and safe manner led, early in the century, to the joint use of poles at such crossings. The increasing use of overhead power lines has since made it necessary to evolve methods of supporting high-voltage as well as low-voltage power lines on poles shared with Post Office lines.

## INTRODUCTION

It is not generally appreciated that the joint usage of poles by electricity undertakings and the Post Office is not a recent development. It was, when the need arose, used before 1914. In those days and up to about 1920, it was the practice, where high-voltage lines crossed roads, to provide a pole on either side of the road and to carry the high-voltage conductors across on insulators suspended from a catenary wire. In some situations the crossing of Post Office overhead routes by the power lines could not be avoided and the crossing was sometimes effected by the joint use of a pole (Fig. 1). To

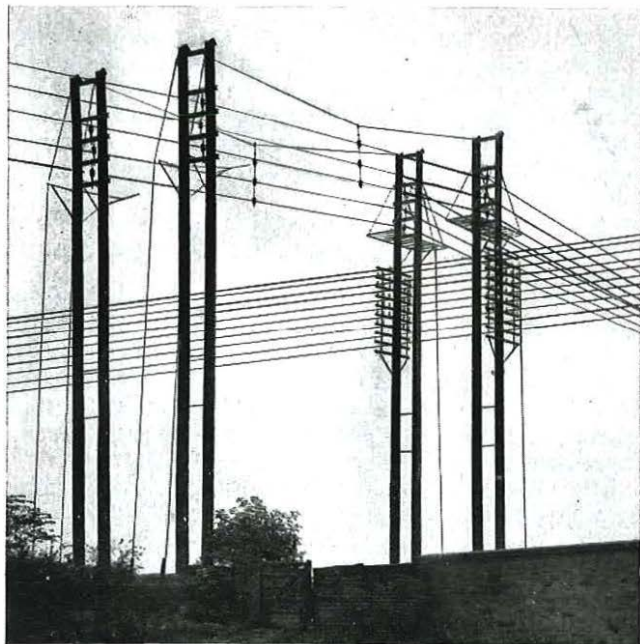

FIG. 1—JOINT USE OF HIGH-VOLTAGE POWER-LINE POLES

protect linemen working on the telephone wires, an earthen grille, two of which can be seen in the illustration, was provided between the telephone and power conductors.

Electricity undertakings also used joint construction for their own telecommunication services, the Yorkshire Electric Power Company being particularly active in this respect. Even as early as 1907, this company was attaching telephone conductors to overhead power lines, and the methods used are described below.

## THE YORKSHIRE ELECTRIC POWER COMPANY'S SYSTEM

When setting up their system, about 1905, the Yorkshire Electric Power Company obtained from the Post

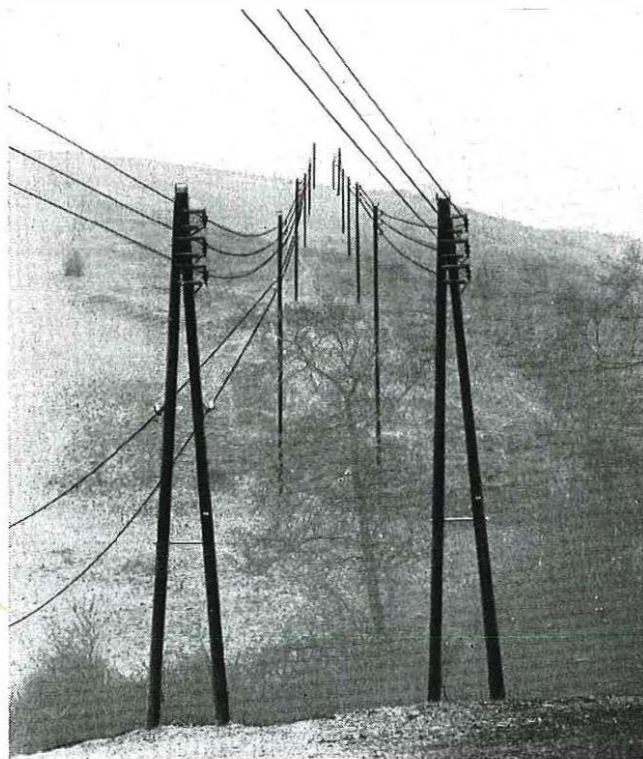

FIG. 2—YORKSHIRE ELECTRIC POWER COMPANY'S LINE CARRYING 11 KV POWER CONDUCTORS AND TELEPHONE WIRES

Office a licence to operate a private telephone system for the control of their network. The company's original transmission system consisted of high-voltage feeders, each about 10 miles long, radiating from a power station. Some of these routes were overhead, and on one, an 11 kV route, bare wires of the company's private telephone system were carried 5-6 ft below the power conductors (Fig. 2). The telephone circuits consisted of single pairs of wires transposed a quarter turn at every pole. The white insulators of the telephone line can be seen in flat formation on the near left-hand pole and in vertical formation on the next pole.

As there was risk of contact between the power and telephone wires, and an adequate insulating cover to prevent contact was not at that time available for either type of conductor, it was necessary to provide protection at the terminal points of the telephone conductors. This protection took the form of a fuse in each conductor, followed by an over-voltage protector. A transformer was used to isolate the line from the terminal equipment, while a second set of over-voltage protectors was connected across the lines between the transformer and telephone instrument.

Initially, the system worked satisfactorily but, as the company's network expanded and jointly-used routes up to 30 miles in length were introduced, difficulties arose. In particular, the induced noise on the line tended

† External Plant and Protection Branch, E.-in-C.'s Office.

to mask the signal. Furthermore, it was found that when a fault occurred on the high-voltage line, the over-voltage protection on the telephone line flashed over and put the circuit out of commission just when it was most needed.

Nevertheless, the system served the company and its successor, the Yorkshire Electricity Board, well and is still in use on some routes.

#### JOINT USE OF POLES FOR TELECOMMUNICATION AND LOW-VOLTAGE POWER SUPPLY

The Postmaster General is empowered by Section 20 of the Electric Lighting (Clauses) Act 1899 to lay down requirements for the protection of his lines against induction or other forms of disturbance, including contact from power wires. These requirements, which must be readily available to the electricity supply industry, are published in the form of memoranda. One of these documents, "Memorandum on the protection of Post Office lines from low or medium voltage power lines," issued in February, 1939, included a section specifying the conditions under which power wires could be attached to Post Office poles. In this memorandum it was stipulated that the power conductors other than the neutral conductor should have a covering of insulating paper with a lapping of cotton and a cotton braid overall, the cotton and cotton braid being impregnated with a mixture containing a high proportion of red lead. Because paper-braided jute had originally been used, such a covering was known as P.B.J. It was also stipulated that the power conductors had to be attached above the Post Office wires, which were bare, and that there should be a clearance of not less than 1 ft 9 in. between the topmost Post Office wire and the lowermost power conductor if the attachment was to one pole, and not less than 3 ft if attachments were made to two or more consecutive poles. A maximum of six spans of jointly-used plant were permissible.

Theoretically, the Post Office requirements were such that the power conductors could be attached directly to the Post Office pole, but in practice, to achieve the necessary clearances without reconstruction of Post Office plant, it was usual for electricity undertakings to fit a metal extension piece to the Post Office pole to carry the power conductors; Fig. 3 shows the arrangement adopted. To provide a safeguard against the metal extension piece becoming live, it was bonded to the low-voltage system neutral conductor.

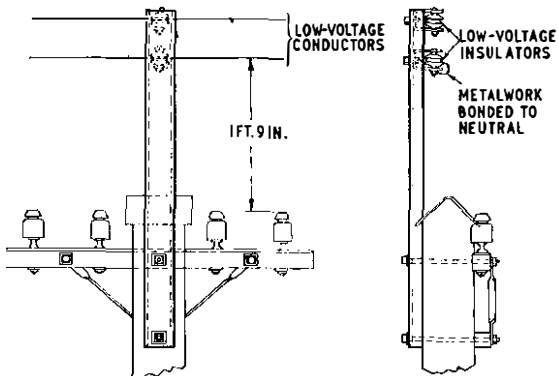

Note: The minimum separation between the power conductors and Post Office conductors is 1 ft 9 in. If attachment is made to consecutive poles the minimum clearance is 3 ft.

FIG. 3.—EXTENSION PIECE FITTED TO POST OFFICE POLE TO CARRY POWER CONDUCTORS

The type of construction described above has, with minor modifications, been retained to the present day.

#### RECIPROCAL AGREEMENT FOR ATTACHMENT OF WIRES TO POLES

Impetus was given to a more general use of shared poles by a parliamentary question posed in 1945 to the then Minister of Fuel and Power. In that question the Minister was asked if it was necessary to have separate sets of poles to carry power and telephone wires in rural areas of the country, it being asserted that failure to share poles was hindering the supply of electricity to the countryside. Resulting from this question, negotiations were opened between the Ministry of Fuel and Power and the Post Office with the object of extending the joint usage of pole lines by low-voltage power and telephone conductors. At that time, however, the electricity supply industry was in the hands of a multiplicity of undertakers using many forms of overhead-line construction. There were, therefore, considerable difficulties in evolving standardized methods of sharing plant or obtaining agreements under which such methods could be put into practice.

The position changed when the Electricity Act of 1947 set up the British Electricity Authority and 14 Electricity Boards, the latter assuming responsibility for the supply of electricity in areas previously covered by some 560 municipal or private undertakings.

Subsequent negotiations carried out with Electricity Boards resulted, in 1951, in the conclusion of an agreement with each individual Board. This agreement permitted joint usage of poles at crossings and in line of route. Such joint usage was restricted to single-phase or 3-phase 50 c/s power lines whose voltage did not exceed 250 volts r.m.s. between phase and earth. To meet the situations most likely to be encountered, the agreement was divided into four parts which set out the conditions to apply when

- (i) the Post Office desired to make attachments to poles belonging to a Board,
- (ii) the Post Office poles were to be recovered at the request of a Board and the Post Office lines transferred to a new line of power poles erected by the Board (this usually applied when a Board was experiencing difficulty in obtaining wayleaves or planning consent),
- (iii) a Board desired to make attachments to poles belonging to the Post Office, or
- (iv) a Board's poles were to be recovered at the request of the Post Office and the Board's conductors transferred to a new line of poles erected by the Post Office.

Considerable use has been made of the joint usage agreement and the pillargraphs in Fig. 4 illustrate the numbers of poles jointly used up to 31 May, 1960. It will be seen that while Electricity Boards have been able to make rather more use of the agreement, by taking over the other party's routes, than has the Post Office, nevertheless, the advantage to the Post Office of the use of simple attachments to power-line poles is very obvious.

The agreement covers joint usage of wood pole routes only, and it is specified that either the live power wires or the Post Office conductors must be insulated with a covering approved by the Post Office. This covering is usually of p.v.c.\* The neutral power conductor is, however, generally left bare. The Post Office conductors must always be below the power wires, the separation between the lowermost power conductor and uppermost

\* p.v.c.—polyvinyl chloride.

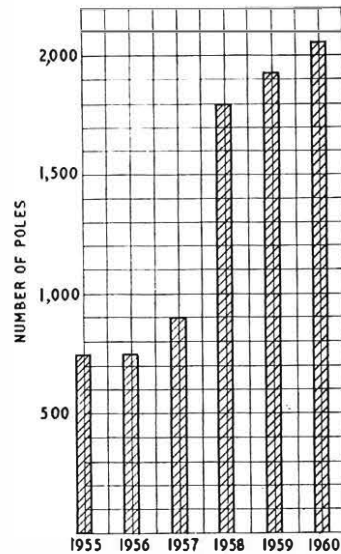
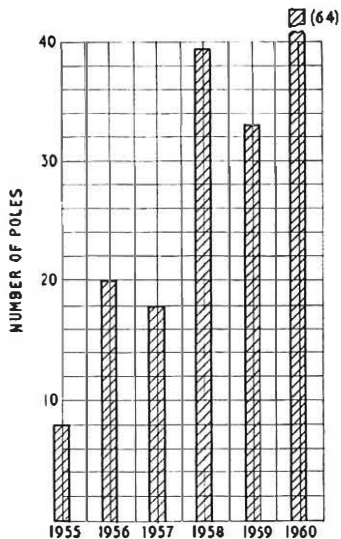
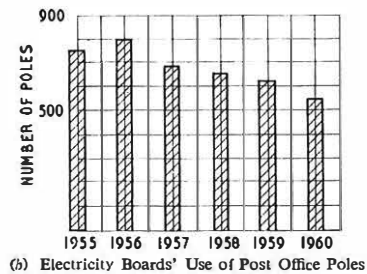
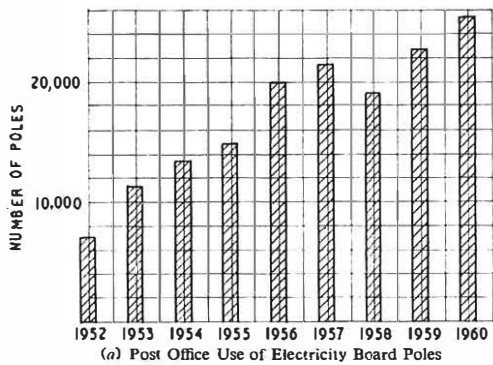

(c) Electricity Boards' Poles Recovered at Post Office Request

(d) Post Office Poles Recovered at Electricity Boards' Request

FIG. 4—PILLAGRAPHS SHOWING INCIDENCE AND TYPE OF JOINT USAGE OF POLES UP TO 31 MAY 1960

Post Office conductor being at least 1 ft 9 in. if the power wires are in vertical formation with a bare neutral lowermost, or 3 ft for all other formations. Fig. 5 shows a typical arrangement with the conductors of the 3-phase system in vertical formation. Here, however, the Post Office wires are very much more than the minimum 1 ft 9 in. below the power conductors, a feature that is deprecated by Electricity Boards as it increases the unsightliness of the line. To avoid this difficulty action has been taken to make the 1 ft 9 in. and 3 ft clearances referred to above specific rather than minimal. The maximum permissible spacing between poles on jointly-used low-voltage routes is 50 yards.

Apart from line-of-route joint usage of poles, there are many instances of sharing single poles at crossings of power and Post Office routes. At such crossings the telephone conductors must always be below the power wires and, if the pole to be used at the crossing is tall enough, the arrangement shown in Fig. 6 can be used. As the telephone wires have to be below the power conductors it is necessary to allow space for four power conductors. Where there are only two power conductors it is usual to fix a metal extension piece, as shown in Fig. 3, to carry them.

#### Types of Telephone Circuit on Jointly-used Poles

There are no restrictions as to the type of telephone line that may share a route with a single-phase or 3-phase

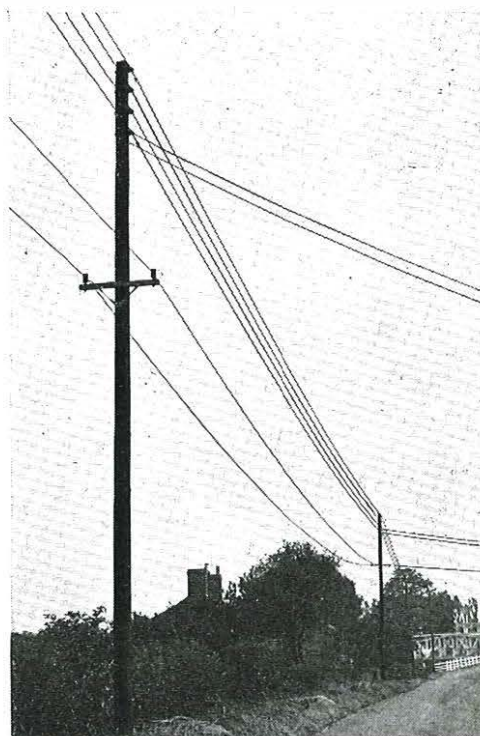

FIG. 5—JOINT USE OF LOW-VOLTAGE POWER-LINE POLE

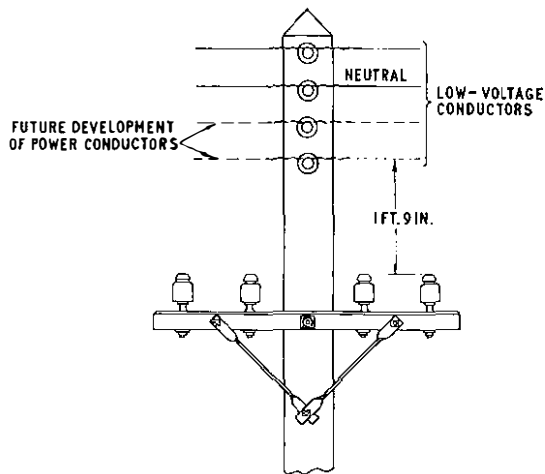

FIG. 6—JOINT USE OF POLE AT CROSSING

power line of a voltage within the specified limits. In practice the major application is on routes giving overhead supplies to domestic electricity consumers and telephone subscribers.

#### Safety Requirements

To ensure the safety of plant and personnel the following requirements are included in the agreement.

(a) The administration owning the poles must make regular inspections, tests and, if necessary, renewals of its poles, and must clearly mark those that are in any way decayed.

(b) If a stay wire requiring a stay insulator is fitted to a power pole, that part of the stay which is above the insulator is considered to be potentially dangerous, and the insulator and stay must be so positioned that Post Office plant or personnel cannot be endangered by possible contact with the part of the stay above the insulator.

(c) Both administrations undertake to maintain their plant in safe condition.

(d) Electricity Boards agree that when they insulate their conductors they will use an insulated wire manufactured to a specification approved by the Post Office.

(e) Neither administration is permitted to attach arms or other fittings to the other's poles in a way that entails cutting the poles.

(f) Electricity Boards undertake to give to the Post Office at least 3 months' notice of any intention to raise the working voltage of their power wires.

Neither the Post Office nor the Electricity Boards use special additional protective devices on their lines because of the joint use of poles, reliance being placed on the insulated covering of one or other group of conductors to prevent contact between the two sets of plant.

Although the terms of the agreement include a clause to the effect that, should it be considered necessary, the power conductors can be de-energized whilst work is proceeding on the telephone wires, this provision is seldom invoked, and by far the greater portion of Post Office work on such routes is carried out with the power conductors live.

#### Interference

The circumstances in which low-voltage power lines share poles with telecommunication lines in the United

Kingdom are such that interference due to fundamental-frequency induction or noise is unlikely. The majority of jointly-used routes are only of the order of some hundreds of yards in length and the voltages and currents in the power systems are relatively low. In consequence, the telephone circuits do not suffer from interference or difficulties due to their close proximity to the power conductors.

#### Accidents

There has only been one accident on jointly-used pole routes since the agreement on sharing the use of poles was introduced. The accident occurred on a pole carrying a metal extension piece. In accordance with standard practice the neutral conductor of the power line carried by the extension piece was electrically bonded to the extension piece but, because of a mistake, the phase and neutral connexion had become reversed at a point remote from the jointly-used pole, and the extension piece became live. When a Post Office employee working on the pole touched both the extension piece and an adjacent Post Office line wire that was at earth potential, he received an electric shock and fell to the ground, sustaining severe injuries as the result of the fall.

#### JOINT USE OF POLES SUPPORTING HIGH-VOLTAGE LINES

For various reasons mainly connected with the difficulty of preventing contact between power and telecommunication conductors and the supersession of the main overhead trunk routes, the arrangement shown in Fig. 1 fell into disuse as far as Post Office plant was concerned, and it was not until 1937 that interest in the joint use of poles carrying high-voltage lines revived. At that time the Electricity Commissioners made certain concessions to electricity supply undertakers permitting the construction of a light form of power line operating at voltages up to 6.6 kV. Such lines were intended to facilitate the provision of electricity supplies to rural areas. Since these power lines would mainly be erected along roads, they would inevitably need to cross Post Office overhead wires. To enable crossings to be made with minimum risk the Post Office agreed to attach their wires to the power poles. It was, however, stipulated that the Post Office wires should have a covering of P.B.J. Furthermore, not more than four Post Office wires could be attached to any one power pole. Other requirements were that the conductors of the high-voltage system should be arranged with an earthed conductor lowermost and that a guard, bonded to that earthed conductor, should be provided on each pole to which Post Office conductors were attached. For a 3-phase high-voltage line, one phase conductor could form the earthed conductor if desired. It was also specified that the Post Office wires should not be less than 3 ft below the earthed conductor of the high-voltage system.

On occasion, low-voltage wires were also attached to poles of light rural power lines. In these circumstances the Post Office wires had to be at least 1 ft 9 in. below an earthed low-voltage conductor. Fig. 7 shows a typical arrangement of a jointly-used pole constructed to the above requirements carrying, from the top downwards, high-voltage, low-voltage and Post Office lines. The inverted "rakes" just below the high-voltage wires are the earthed guards referred to above.

Although plant was shared to a limited extent in the 1930s, only crossings were involved. In 1946, however, the East Anglian Electric Supply Company, who were

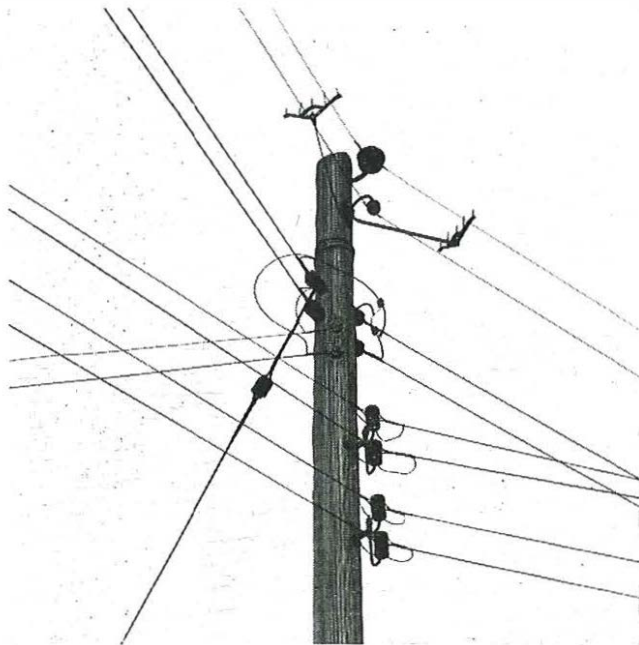

FIG. 7—JOINT USE OF POLE CARRYING HIGH-VOLTAGE, LOW-VOLTAGE AND POST OFFICE CONDUCTORS

in difficulties with wayleaves on a certain proposed 6.6 kV route, asked the Post Office if it would be prepared to consider reconstruction of an existing Post Office route some three quarters of a mile long to carry both Post Office wires and high-voltage and low-voltage power conductors. The proposal was agreed by the Post Office, which, in order to protect its wires, stipulated

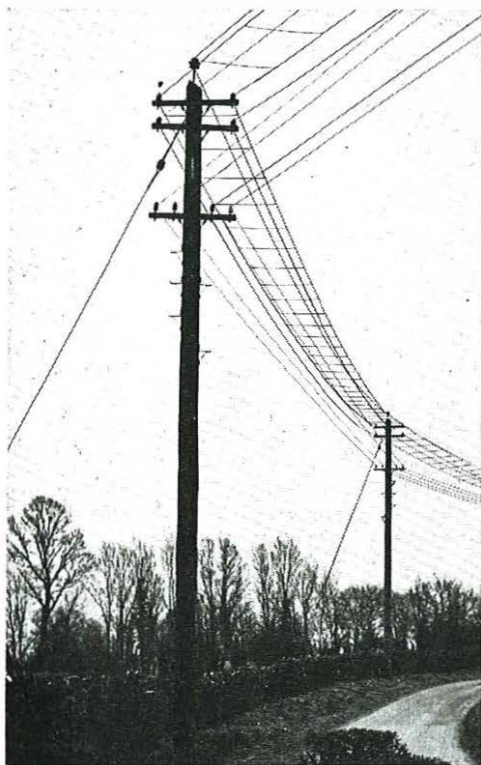

FIG. 8—JOINTLY-USED ROUTE CARRYING SINGLE-PHASE 6.6 KV LINE, SINGLE-PHASE LOW-VOLTAGE LINE AND TELEPHONE WIRES

that a simple form of guard be interposed between the two sets of plant.

As constructed, the high-voltage route (Fig. 8) consisted of a single-phase 6.6 kV line, the live power conductor of which was carried on insulators fitted at the pole top. The neutral was split and formed into a simple guard by cross lacing. A single-phase low-voltage line with P.B.J. covered conductors was carried in horizontal formation immediately below the split high-voltage neutral, with the bare telephone wires 3 ft below the low-voltage wires.

This route and another similar but somewhat shorter line, constructed in the vicinity later, remained in trouble-free service for about 15 years. Nevertheless, the cost of protecting the telephone lines against contact with the power wires was too high to warrant the general introduction of this form of construction and no further routes were built.

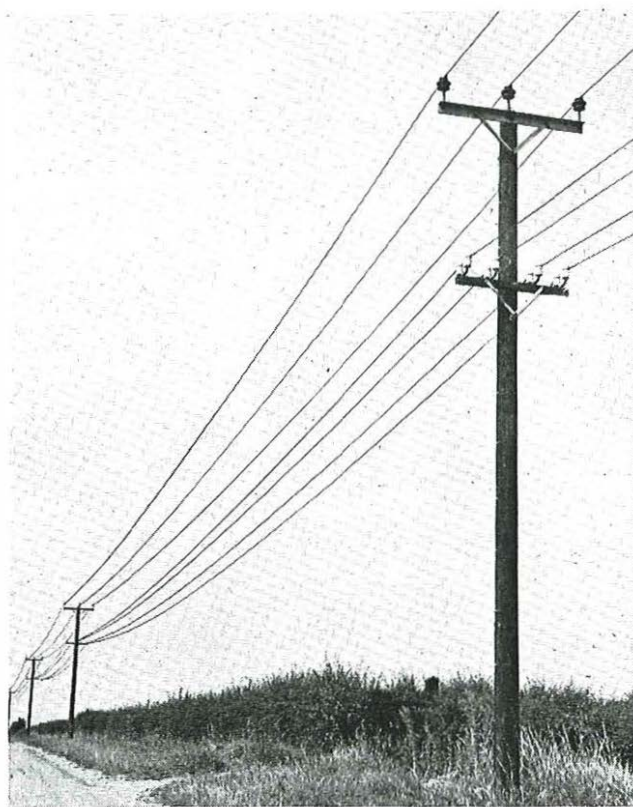

FIG. 9—JOINTLY-USED ROUTE CARRYING 11 KV POWER LINE

#### RECENT DEVELOPMENTS IN THE JOINT USE OF ROUTES CARRYING HIGH-VOLTAGE CONDUCTORS

A recent development has been the erection by Electricity Boards and the Post Office of a number of pole routes carrying high-voltage power conductors and telephone wires or aerial cables. Here the voltage of the power wires may not exceed 11 kV.

Experience with early schemes showed that if such routes did not exceed about half a mile in length there were no difficulties due to induced noise or high electrically induced fundamental-frequency voltages. Above this length, however, these phenomena became apparent, particularly with single-phase lines. For the present the sharing of plant with high-voltage power lines is therefore

limited to lines not exceeding half a mile in length. Experiments are, however, proceeding with longer routes.

As when plant is shared with low-voltage power lines, telephone conductors are only permitted to be fitted below high-voltage power wires, but there must be a minimum separation of 6 ft between the two sets of conductors. If open wires are used they must be insulated with 0.06 in. of p.v.c., and if the telephone conductors are in a cable this must be polythene or p.v.c. sheathed. The power conductors are generally bare. Span lengths have been provisionally limited to 50 yards. Experiments have, however, been carried out with spans up to 100 yd and recent developments in aerial-cable construction will enable such spans to be adopted as standard.

Post Office line wires or aerial cables are not attached to poles having exposed high-voltage conductors at low level, e.g. poles carrying transformers or switchgear. Routine maintenance work on Post Office conductors carried on poles that also support high-voltage wires is normally done with the power wires live but, to protect Post Office staff against leakage currents from faulty high-voltage equipment, all metal work supporting high-voltage conductors must be permanently bonded to earth.

A jointly-used route with high-voltage power conductors operating at 11 kV is shown in Fig. 9.

A number of routes have also been constructed that carry, from the tops of the poles downwards, high-voltage wires in horizontal formation, low-voltage conductors, usually in vertical formation, and telephone wires or aerial cables.

There have been no accidents on the 150 or so jointly-used high-voltage routes that have been constructed during the last six years.

It is hoped that before long there will be a formal agreement with Electricity Boards on the joint use of poles carrying high-voltage power lines. In the meantime each requirement for joint usage is considered separately.

#### ACKNOWLEDGEMENTS

The author would like to acknowledge the help he has received in the preparation of this article from Mr. H. Willott Taylor, Chief Engineer of the Southern Electricity Board, and to thank Messrs. H. S. Moody and H. Lloyd, Assistant Chief Engineers of the Yorkshire Electricity Board, for supplying the information relative to the Yorkshire Electric Power Company's system. Acknowledgement is also due to the Yorkshire Electricity Board for permission to publish the latter information.

---

## Progress in the Provision of Subscriber Trunk Dialling

U.D.C. 621.395.374

#### INTRODUCTION

WHEN subscriber trunk dialling (S.T.D.) was brought into use for the first time in the United Kingdom at Bristol exchange on 5 December 1958,\* plans were already being made for the gradual introduction of the service throughout the Post Office telephone system.

The background to those plans was that the system contained some 6,000 exchanges serving 4.5 million exchange connexions, and that it was expected to grow at the rate of approximately 170,000 connexions per year. The system carried about 330 million inland trunk calls per year, and trunk traffic was then expected to grow at about 4 per cent per year in the system as a whole plus an average increase of 20 per cent at individual exchanges when S.T.D. became available. The 6,000 exchanges consisted of approximately

320 director exchanges,

580 non-director exchanges (including satellites),

4,050 unit automatic exchanges (U.A.X.s),

and 1,050 manual exchanges (about half of which would be converted to director and non-director exchanges, and the other half to U.A.X.s).

The plans for nation-wide S.T.D. therefore required a concurrent plan for conversion of the remaining manual exchanges to automatic working, and the cost of this work plus the cost of providing S.T.D. equipment (each of which was estimated to be between 35 and 40 million pounds for completion of the work by about 1970) did

not allow plans envisaging earlier completion than 1970.

Since 1958 it has become necessary to cater for growth of the system at the increased rate of 250,000 connexions per year and for growth of trunk traffic at 10 to 12 per cent per year, but it has not been found necessary to depart from the original target of providing S.T.D. equipment to enable 90 per cent of trunk calls to be dialled by subscribers by 1970. Also, since 1958, register-translators have been developed that can serve up to three different charging groups and this has reduced the number of group switching centres (G.S.C.s) required for nation-wide S.T.D. to some 375.

#### PROGRESS IN PROVIDING S.T.D.

Existing automatic exchanges contain equipment of varying ages up to 45 years and it is, therefore, necessary to provide for S.T.D. at exchanges containing all types of 50-volt step-by-step equipment from pre-2,000-type with pre-3,000-type relays to the most modern 4,000-type. Nevertheless, the plans for introducing S.T.D. have not been restricted at any stage by inability to design S.T.D. equipment for use with step-by-step exchanges. In fact, such is the versatility of step-by-step equipment that even the older types of plant are now providing S.T.D. service in conjunction with both electronic and electromagnetic register-translators.

To spread the design work over a reasonable period it was decided to develop S.T.D. equipment for different applications in sequence, and Table 1 shows the dates at which the ordering of S.T.D. for various types of exchange could begin. It was decided not to develop S.T.D. equip-

\* Subscriber Trunk Dialling. *P.O.E.E.J.*, Vol. 51, Part 4, Jan. 1959.

TABLE 1  
Sequence of Development of S.T.D. Equipment

Type of Exchange	Date for Start of Ordering
Bristol Exchange (prototype)	September, 1956
G.S.C.s in non-director areas	June 1957
Remote non-director exchanges with group-selector-type equipment	April 1958
Group-selector satellite exchanges	April 1958
Director exchanges	July 1958
G.S.C.s in director areas	January 1959
Incoming trunk automatic exchanges in director areas	January 1959
Discriminating satellite exchanges	April 1959
Remote non-director exchanges with discriminating-satellite-type equipment	April 1959
Non-director exchanges (other than G.S.C.s) in charging groups adjacent to the London director area	July 1959
U.A.X.s No. 12, 13 and 14	March 1963 (target)

ment for the few non-standard exchanges in the system, e.g. those with common-control or by-path equipment, or for use with certain other old patterns of equipment, such as Siemens 16, 100-outlet first-code selectors and U.A.X.s No. 7, which would become due for replacement before an economic life could be obtained from their S.T.D. equipment.

The ordering of S.T.D. equipment built up rapidly after 1957 until now it is normal practice to include it in all contracts for new exchanges and extensions of existing exchanges if the G.S.C. for the exchange is already working or will be brought into service during the design period of the contract. At present 80 per cent of contracts include the provision of S.T.D. equipment.

After the prototype S.T.D. equipment was brought into service at Bristol in December 1958 nearly 12 months elapsed before the second installation was ready for service. From then on the program gathered momentum,

as is shown by Table 2, until, by the end of 1961, 69 G.S.C.s were working and S.T.D. was available at 178 exchanges serving 675,000 working connexions, i.e. S.T.D. was in service in 13.5 per cent of the Post Office telephone system.

In addition to the S.T.D. equipment already working, other contracts placed before 31 December 1961 will provide for 124 more G.S.C.s and 477 exchanges serving approximately two million more connexions. Most of this equipment will be in service by the end of 1963, so that by then S.T.D. will have been extended to just over half of the system.

This high rate of ordering of S.T.D. equipment is already planned to continue up to 31 March 1963; by which time S.T.D. will have been either provided or ordered for:

(a) two thirds of the number of G.S.C.s required,

(b) 860 out of approximately 1,400 director and non-director exchanges that will exist when all manual exchanges have been converted to automatic working (and these 860 exchanges will include nearly all the very large ones), and

(c) approximately 65 per cent of the working connexions in the telephone system.

#### CONCLUSION

The progress made in providing S.T.D. is well in line with the original plans for having the provision of S.T.D. throughout the Post Office telephone system substantially completed by 1970, and it is noteworthy that the original estimates of the cost of providing S.T.D. equipment do not differ appreciably from the actual costs for the work completed to date. Furthermore the cost of exchange equipment to provide S.T.D., excluding the costs of exchange equipment associated with pay-on-answer coin-boxes and local-call timing which are being provided concurrently with the S.T.D. equipment, is comparable to the cost of equipment required to handle the same amount of trunk traffic manually.

W.A.H.

TABLE 2  
Growth of S.T.D. in Each Quarter Since September 1959

Quarter Ended	G.S.C.s		Exchanges provided with S.T.D.		Working Connexions having S.T.D. (Note)		Percentage of System having S.T.D.
	Opened in Quarter	Total Working at End of Quarter	During Quarter	Total at End of Quarter	At Exchanges provided with S.T.D. during the Quarter	Total	
31 Dec. 1959	1	2	1	2	600	8,000	0.15
31 Mar. 1960	1	3	2	4	2,500	10,500	0.2
30 June 1960	1	4	3	7	10,500	21,000	0.4
30 Sept. 1960	1	5	2	9	16,000	37,000	0.75
31 Dec. 1960	10	15	14	23	53,000	90,000	1.8
31 Mar. 1961	22	37	34	57	110,000	200,000	4
30 June 1961	12	49	27	84	95,000	295,000	6
30 Sept. 1961	8	57	40	124	180,000	475,000	9.5
31 Dec. 1961	12	69	54	178	200,000	675,000	13.5

Note: The number of working connexions at each exchange provided with S.T.D. has increased since the date that S.T.D. was provided. The approximate numbers of working connexions at 31 Dec. 1961 have therefore been shown throughout this table.

# SCOTICE—The United Kingdom to Iceland Cable System

U.D.C. 621.395.51 (411 + 491.1): 621.315.28

**I**N a year (1961) that will be remembered in North Atlantic telecommunications history for the completion and opening for service of the CANTAT<sup>1</sup> submarine cable system, another North Atlantic cable system was in the process of being completed. This system, which was provided as a joint undertaking by the Great Northern Telegraph Co., Ltd., of Denmark, the Danish P.T.T., the Icelandic P.T.T. and the U.K. Post Office, connects the United Kingdom with the Faroes and Iceland and has been given the code name SCOTICE. The cable and repeaters were laid during the late autumn of 1961, the final cable splice being made on 17 December 1961. The system was opened for service on 22 January 1962.

The SCOTICE system is made up of two independent submarine cable systems, termed the northern and southern sections. The northern section, linking Vestmannaeyjar, Iceland, with the Faroes, comprises approximately 408 nautical miles (n.m.) of 0.46 in. diameter coaxial cable with 15 submerged repeaters and one submerged equalizer. The cable terminates in the Faroes at Torshavn which is 5.4 n.m. from the cable landing point at Velbestad. The southern section, consisting of approximately 290 n.m. of 0.46 in. coaxial cable and 10 submerged repeaters, joins together Torshavn and Gairloch in Ross-shire, Scotland. The greatest depth in which the cable is laid is approximately 1,000 fathoms.

The shore end of the cable at Gairloch was laid in advance of the main link by H.M.T.S. *Ariel*, and shore ends at Velbestad and Vestmannaeyjar were laid by

C.S. *Edouard Svenson* of the Great Northern Telegraph Co., Ltd. The northern section of the main link was laid by H.M.T.S. *Alert* and the southern section by C.S. *John W. McKay* of the Commercial Cable Co., under charter to the Great Northern Telegraph Co., Ltd.

Although the Post Office is not a financial partner in the northern section, the complete system was of great interest to the Post Office for the following reasons:

(i) It was the first submarine system landing in the United Kingdom to use 0.46 in. diameter polythene-insulated coaxial cable.

(ii) It was the first submarine system terminating in the United Kingdom to be equipped from the start with 3 kc/s-spaced channel equipment.<sup>2</sup>

(iii) The complete system between group distribution frames was designed and engineered by a contractor, Standard Telephones and Cables, Ltd.

The capacity of each section is 24 3 kc/s-spaced channels; one group of 16 channels is extended via a through-group filter at Torshavn to channel equipment at Vestmannaeyjar and Gairloch. The remaining eight channels (or half group) on each section provide channels between Vestmannaeyjar and Torshavn, and between Torshavn and Gairloch.

On each section, Torshavn is the A station, and the frequency bands transmitted over the system are 24–96 kc/s in the A to B direction and 120–192 kc/s in the B to A direction. An additional frequency band of 6 kc/s at the lower and upper ends of the frequency spectrum is used to provide maintenance facilities. Special frequency-translating equipment at the submarine



Left to right at table (facing camera) His Excellency Mr. Henrik Sv Bjornsson, Icelandic Ambassador; His Excellency Mr. N. T. Svenningsen, Danish Ambassador; Miss Mervyn Pike, M.P., Assistant Postmaster General; The Hon. Christopher Woodhouse, M.P., Parliamentary Secretary to the Minister of Aviation; Sir Ronald German, C.M.G., Director General of the Post Office; His Excellency Mr. Hugh J. McCann, Republic of Ireland Ambassador.

MISS MERVYN PIKE, M.P., ASSISTANT POSTMASTER GENERAL, INAUGURATING THE SCOTICE SYSTEM AT THE G.P.O. HEADQUARTERS



cable terminal stations gives the necessary translation to and from the full-group range of 60-108 kc/s and the half-group range of 60-84 kc/s. Group reference pilots of 84 kc/s are provided on both the full and half groups.

Connexion between Vestmannaeyjar and Reykjavik, a distance of about 72 miles, is by means of a new 24 channel v.h.f. radio link. Between Gairloch and Inverness 24 channels are provided on audio cables with intermediate repeater stations at Achnasheen and Dingwall. To guard against variations in attenuation due to temperature changes on the aerial-cable section between Gairloch and Achnasheen, audio a.g.c. equipment is provided at Gairloch, which operates on the change in d.c. resistance of the phantoms of the circuits. Between Inverness and London International Maintenance Centre (I.M.C./A),<sup>3</sup> two 12-channel groups are provided over separate routes, one via a 24-circuit carrier system and one via a mixed carrier and coaxial route.

The SCOTICE system was inaugurated by Miss Mervyn Pike, M.P., Assistant Postmaster General, in London, Mr. Ingolfur Jonsson, the Icelandic Minister of Posts and Telegraphs, in Reykjavik, and Mr. Peter Mohr Dam, the Lagmand (Lord Lieutenant) of the Faroes, in Torshavn. The photograph shows the ceremony in London.

The system provides initially London-Reykjavik telephone and v.f. telegraph circuits, London-Torshavn telephone and v.f. telegraph circuits, Copenhagen-Reykjavik and Copenhagen-Torshavn circuits (via London) together with an omnibus speech circuit and v.f. telegraph channels for air-traffic control purposes leased by the International Civil Aviation Organization (I.C.A.O.).<sup>4</sup>

The telephone circuits are operated on a manual basis, 500/20 c/s generator signalling being employed; the exception is one Torshavn-Copenhagen circuit which is

operated on a semi-automatic basis. In late 1962 or early 1963 the Copenhagen-Reykjavik circuits will be operated on a semi-automatic basis. At Torshavn 2-wire pad switching is used, and 4-wire switching is used at London on transit calls. At present 2-wire pad switching is used at Reykjavik but this will be changed to 4-wire switching in 1963. Differential far-end-operated half echo-suppressors are used on the circuits, the echo suppressors being installed at London, Copenhagen, Torshavn and Reykjavik.

Other telephone and telegraph facilities are provided between Iceland and the Faroes. Telephone and telegraph speaker circuits for maintenance use are also provided over the system. It remains to be seen to what extent telephone and telegraph traffic between the United Kingdom and the Faroes and Iceland is stimulated by the provision of the SCOTICE system, but first impressions are very favourable.

The completion of the ICECAN<sup>5</sup> submarine cable system, which will link with the SCOTICE system at Vestmannaeyjar in late 1962, is awaited with interest. Apart from completing the full requirements for the International Civil Aviation Organization circuits it will provide another possible communication link between the continents of Europe and North America.

F.H.

#### References

- <sup>1</sup> CANTAT—A New Submarine Telephone Cable System to Canada. *P.O.E.E.J.*, Vol. 54, p. 220, Jan. 1962.
- <sup>2</sup> LAW, H. B., REYNOLDS, J., and SIMPSON, W. G. Channel Equipment Design for Economy of Bandwidth. *P.O.E.E.J.*, Vol. 53, p. 112, July, 1960.
- <sup>3</sup> STOTESBURY, K. E., and BYRNE, S. H. L. The London International Maintenance Centre. *P.O.E.E.J.*, Vol. 52, p. 96, July 1959.
- <sup>4</sup> KELLY, P. T. F. Circuits for International Civil Aviation. *Post Office Telecommunications Journal*, Vol. 13, p. 189, Autumn 1961.
- <sup>5</sup> The SCOTICE/ICECAN Submarine Cable Projects. *P.O.E.E.J.*, Vol. 53, p. 56, Apr. 1960.

## Book Review

“Mathematics for Telecommunications and Electrical Engineering.” Vol. 2. D. F. Spooner, B.Sc., and W. H. Grinstead, O.B.E., M.I.E.E., F.C.G.I. The English Universities Press, Ltd. xiv + 514 pp. 159 ill. 15s.

The authors of this book should need no introduction to students of telecommunication engineering, and, although there are many text books on the fundamental material covered, it should be comforting to students taking the City and Guilds' Telecommunication Technicians' Course to know that this book has been written to meet their needs and that one of the co-authors is the chief examiner in mathematics.

The book is in two distinct parts: Chapters 1 to 7 cover the Mathematics B syllabus of the third year of the Technicians' Course, with adequate revision of earlier work, and the remaining five chapters deal with Mathematics C, the final year of that course. The general treatment and worked examples have a strong telecommunications bias but the book could well be used by National Certificate students for the new 01 and 02 courses.

An attractive feature of this book is the care taken by the authors to explain each item in clear, concise and simple language, amply supported by illustrative examples. The

figures and graphs have obviously been prepared by an expert, and it is a pity that the editorial work is not of an equally high standard. There are many small but annoying errors in the text; for example, in one instance  $\cos 15^\circ$  is given as  $1/\sqrt{2}$  (obviously a misprint), and in one of the worked examples diametral and radial values are confused.

In Chapter 8 it is incorrectly stated that  $\frac{d}{dx}(\tan x) = \sec^2 x$  is demonstrated in the previous chapter, and in Chapter 7 it is also wrongly claimed that the relations  $\frac{d}{dx}(\sin x) = \cos x$  and  $\frac{d}{dx}(\cos x) = \sin x$  are proved in Chapter 10.

There is a liberal supply of exercises for the students to solve, many being taken from past examination papers, and a further valuable feature of the book is the inclusion, with answers, of complete City and Guilds' examination papers and comparable papers used for National Certificate courses. If these exercises are used conscientiously, an industrious student will be able to acquire not only the ability to pass the examination, but also a sound experience in the application of fundamental mathematical principles that will prove most useful should he embark on more advanced studies.

*I.P.O.E.E. Library No. 2619.*

G. H. K.

# Cooling System for High-Power Radio Transmitters

A. E. N. WASE, A.M.I.E.E.†

U.D.C. 621.396.61--71

A cooling system for high-power radio transmitters is described with particular reference to a new method of cooling transmitting valves by water-vaporization, which has advantages over conventional water or forced-air cooling.

## INTRODUCTION

RADIO transmitters used for point-to-point h.f. communication have an overall efficiency of about 37 per cent, so that a typical transmitter which is rated at 20 kW continuous radio-frequency (r.f.) output power has a total power consumption of 54 kW. Thus, approximately 34 kW of electrical energy is dissipated as heat within the complete transmitter installation and has to be removed by means of a cooling system which comprises an important part of the transmitter equipment.

Of the 34 kW energy dissipated as heat, some 5 kW are due to transformer and motor losses outside the transmitter enclosure and up to 2 kW are dissipated within the transmitter by radiation and convection. The remaining 27 kW are dissipated in fairly high concentrations in the power-amplifying stages of the transmitter, and it is the main function of the cooling system to remove this heat and so keep working temperatures within acceptable limits. Most of this energy is dissipated in the valve anodes of the main power amplifiers which may be cooled either by forced-air or water. Certain components, such as inductors and contacts, carrying large r.f. currents also require special cooling by directing jets of forced air on to them, and general cooling by air ventilation of each cabinet is necessary in a large transmitter installation.

After dealing briefly with the methods in current use for cooling high-power valve anodes a new method, shortly to be introduced into Post Office radio stations and which promises important economic and technical advantages, is described in some detail.

## METHODS OF REMOVING HEAT FROM VALVE ANODES

The three methods of cooling a valve anode, which are at present in common use, are direct radiation, forced-air cooling and water cooling.

Valves of up to about 1.5 kW anode dissipation can be cooled by direct-radiation cooling of the anode through the envelope but above this rating they become inconveniently large and fragile. Silica-envelope valves were made in the past for greater dissipations than this but for the larger valves, in modern practice, the anode is made as part of the valve envelope. The cylindrically-shaped copper anode can then be cooled either by immersion in water or, with radial fins attached to form a radiator, by forced-air.

Forced-air cooling is most generally adopted for cooling valves of moderate rating, exceptionally up to about 40 kW anode dissipation. A finned copper radiator is soldered to the external surface of the cylindrical copper anode and air is forced through the small passage-ways between the fins at considerable velocity. Sufficient air

must flow to enable the heat transfer from the anode to the air to keep the temperature of the anode from exceeding about 200°C and the temperature of the glass-to-metal anode seal from exceeding about 180°C. Air is the most readily available and easily handled cooling agent, but its inherently low specific heat and, therefore, low thermal capacity entails the use of large volumes. Thus, a typical valve anode dissipating 20 kW requires an air flow of 1,500 ft<sup>3</sup>/min at a pressure of 3 in. water-gauge; a pumping power of about 1 kW is needed and the temperature of the air is raised by 22°C. Higher pressures have been used but are not favoured by the Post Office as they lead to excessive noise levels in the transmitter hall.

Water cooling a valve anode mounted in an external jacket through which the water is pumped, provides a more effective means of removing heat than air cooling and permits the anode-dissipation rating of a valve to be increased by 50 per cent. Water cooling is not often used for valves rated at less than 10 kW anode dissipation but valves of this type are readily available for powers up to 50 kW and have been made with anode dissipations of the order of 200 kW. Steam bubbles which form on the anode surface must be brushed off by using a high-velocity water flow to prevent formation of local hot spots. A water supply of 8 gallons/minute at a pressure of 25 lb/in<sup>2</sup> is required to cater for a typical valve-anode dissipation of 20 kW; the temperature of the water is raised by 8°C and about 200 watts of pumping power is needed, which shows an appreciable economy compared with forced-air.

## THE NEW METHOD OF COOLING VALVE ANODES

A new method of cooling high-power valves by vaporization of water has been developed during recent years; it uses a specially constructed thick-walled anode immersed in water in a small boiler. Usually, deep channels are cut in the external surface or cylindrical waterways are bored axially through the anode, although in some designs massive teeth have been provided giving the anode a pineapple appearance. A channelled-anode type of vapour-cooled valve is shown in Fig. 1, and the valve in its boiler jacket, is shown in Fig. 2. The heavily-ridged construction substantially increases the external surface area of the anode in contact with the coolant and aids dispersion of steam bubbles which are created in the regions at the roots of the channels, i.e. nearest to the internal anode surface. Heat is removed from the anode by conversion of the cooling water into steam, which causes considerable turbulence of the water and rapidly causes the steam bubbles to be conveyed away from the anode to the surface. The maximum permitted anode-surface temperature is 125°C at the roots of the channel, because above this temperature vigorous boiling occurs at the ridges, preventing adequate wetting by the water and so insulating the anode. In practice the maximum operating temperature is usually about 110°C to prevent the possibility of this happening. The steam generated passes to a condenser and the water formed is returned by gravity to the boiler.

† Overseas Radio Planning and Provision Branch, E-in-C.'s Office.



FIG. 1—CHANNELLED-ANODE TYPE OF VAPOUR-COOLED VALVE

For a typical vapour-cooled valve operating with 20 kW anode dissipation and using forced-air for cooling the steam condenser, about 500 ft<sup>3</sup>/min air flow at 4 in. water-gauge is required; the air would be raised in temperature by 65°C. Alternatively, a water-cooled condenser would need one gallon of water per minute. The simplicity of the cooling plant is illustrated in the arrangement shown in Fig. 3, and, as the water level in



FIG. 2—THE VAPOUR-COOLED VALVE IN ITS BOILER JACKET

the valve boiler jacket is maintained by the small header-tank, no circulating pump is required. This is essentially a low-pressure system and is open to the atmosphere to avoid steam pressure building-up under fault conditions.

The advantage of water-vapour cooling over the older methods is that the water is allowed to boil, and thus by taking up its latent heat of vaporization increases the efficiency of the heat-transfer process many times. The temperature of the external surface of the anode is raised but the special design of the anode ensures that the internal surface temperature is not increased. The temperature gradient across the condenser is much larger than in the heat exchangers of the earlier systems, which also improves the heat-transfer efficiency and enables the quantity of water and overall size of the installation to be greatly reduced. Considerably less air or water-flow is necessary compared with previous methods, and the coolant is raised to a higher and more useful temperature, which can be exploited more readily for space-heating purposes.

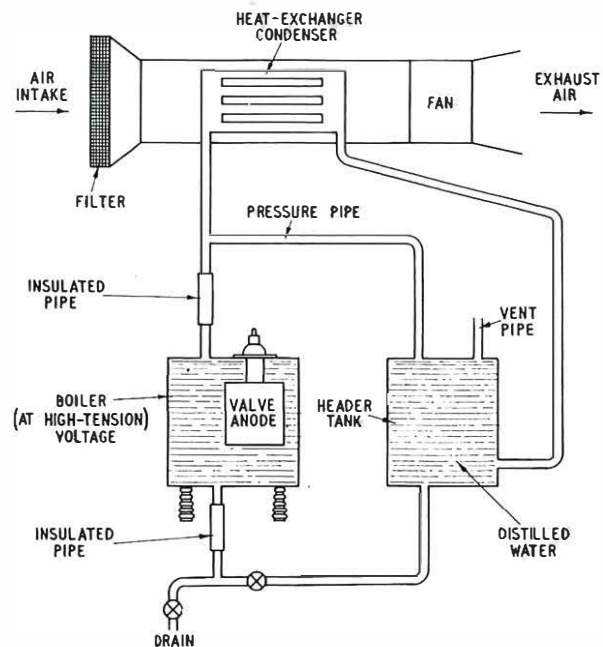

FIG. 3—WATER-VAPOUR COOLING SYSTEM

#### THE COMPLETE TRANSMITTER COOLING SYSTEM

Forced-air ventilation necessarily has to be provided in most modern transmitters not only for removing heat from the anodes of the larger valves but also for cooling contacts and inductors which carry large r.f. currents up to the order of 80 amp, to prevent overheating causing damage by oxidization of contact surfaces or softening of joints and connexions. It is also used to cool every amplifier stage, even low-power units, to achieve good gain stability and freedom from de-tuning effects arising from temperature changes in circuit components.

Usually forced-air ventilation is also required for auxiliary cooling of the glass-to-metal seals of most large valves, including water-cooled and vapour-cooled valves operating at maximum rating. It is also necessary for cooling the envelopes of mercury-rectifier valves used for d.c. high-voltage supplies to keep the operating temperature of the lower part of an envelope within the prescribed working limits for mercury-vapour condensa-

tion. Some cooling by forced-ventilation is usually applied to most rectifiers and auxiliary supply equipment sections of a transmitter, even where metal rectifiers are employed.

During the last decade the general trend in design has been towards wholly air-cooled transmitters with self-contained forced-air ventilation systems providing the ventilation required for all parts of the transmitter equipment, using either a single blower or extractor fan. Alternatively, a balanced blower and extractor fan arrangement can be used which eases the problem of making the transmitter cabinets reasonably air-tight. It is now Post Office practice to draw the air supply from the transmitter-equipment hall to provide general ventilation of the room and to re-circulate a proportion of the heated air expelled from each transmitter back into the hall under thermostatic control. Unwanted heated air is ejected to the external atmosphere. Motor-operated louvres vary the amount of air-recirculation from full, when the internal ambient temperature falls to 15.5°C (60°F), to total ejection of the heated air when the internal temperature exceeds 21°C (70°F). The system has shown worthwhile economies in space-heating transmitter buildings.

A fan driven by a 6 h.p. electric-motor is required to provide some 3,000 ft<sup>3</sup>/min air flow at a pressure of 4 in. water-gauge for a practical cooling system of a complete transmitter of 20 kW r.f. output power in which all valves are air-cooled and the temperature of the air is raised by 17°C. Using a vapour-cooled valve in place of an air-blast type in the transmitter output-amplifier stage reduces the total transmitter air-flow requirements to about 1,800 ft<sup>3</sup>/min, for which an electric motor of about 4 h.p. is adequate; the air temperature is raised by 28°C. This waste heat can be used effectively for space-heating purposes and the smaller air flow can be conveyed in more conveniently sized ducts than are required for a transmitter employing

conventional air-cooled valves. Also, the volume of air displaced inside the building is reduced and is less likely to cause draughts when the heated air from a number of transmitters is being fully recirculated.

The advantages of vapour-cooled valves are much more marked in higher-power amplifiers than the 20 kW r.f. transmitter considered in this article, and a typical transmitter using vapour-cooled valves giving 100 kW r.f. output requires about 5,000 ft<sup>3</sup>/min. This is less than half that required for cooling a transmitter of the same size by forced air.

#### CONCLUSIONS

Water-vapour cooling of the anodes of the larger valves effects the removal of waste heat at a higher temperature in the coolant than can be achieved by direct cooling by air or water alone, and also facilitates the design of a more compact ventilation and cooling system for a transmitter installation. The water-vapour system is generally silent and does not produce unpleasant bubbling or hissing noises; care in design can also ensure that the ventilation system is acceptably quiet in operation. Water-cooled or vapour-cooled valves are preferred in many applications because of the higher anode-dissipation ratings potentially available; this may permit, for example, the use of a single valve instead of a pair of air-cooled valves in an amplifier, thereby achieving a simpler circuit arrangement and construction. Also, at high frequencies, where stray circuit-reactance is important, lower stray capacitance to earth may be realized with an anode in a water-jacket than with a large-finned radiator such as is used for forced-air cooling. Increasing use is being made of vapour-cooled valves in high-power h.f. amplifiers, broadcast transmitters and industrial r.f. heaters where the saving in size and cost of the forced-air ventilation system is considerable.

---

## Book Review

"The Arc Discharge. Its Application to Power Control." H. de B. Knight, M.Sc., M.I.E.E., F.Inst.P. Chapman & Hall, Ltd. xix + 444 pp. 209 ill. 63s.

The book is one of a series recommended for publication by the Technical Papers Panels of Associated Electrical Industries, Ltd. It describes single anode valves in which the current is carried by an arc discharge and which can be controlled by grids or ignitors. These valves are generally referred to as thyatrons, excitrons and ignitrons. Rectifiers without control electrodes, however, are also described.

The work is arranged in three main parts, comprising a total of 10 chapters. Part I deals with general principles, characteristics and construction, Part II with physical processes in the discharge and Part III with the various applications of the valve.

The early chapters describe the functions of the valve as an electronic switch, the flow of electrons and ions, the design and construction of the hot-cathode rectifier and other types of hot-cathode valves. Later chapters discuss the general theory, thermionic emission, particle collision,

and the various physical processes and characteristics of the discharge. The last four chapters are of most interest and use to the practical engineer as they contain many practical applications, such as half-wave and full-wave rectification, and the various single-phase and three-phase bridge rectification circuits. The factors affecting regulation of the output voltage are discussed as well as the manner in which valves may be employed as switches to control the current supplied to a.c. loads. The different methods of controlling the grid are described, whilst the interpretation of manufacturers' specifications and ratings, and the notes on operation and maintenance, are very useful. There are four rather academic appendices dealing with units, fields of force, gases, vapours and particle concentration.

The book is clearly written and well produced and can be read and understood without an extensive knowledge of mathematics. It will be very useful to those concerned with the use of valves for power supply, rectification and control purposes. For the reader who wishes to probe further into any particular aspect of the subject there is a very comprehensive bibliography at the end of each chapter.

R. S. P.

# The Use of Hammer Finish on Apparatus

U.D.C. 667.66

THE surface coating known as "hammer" or "hammered" finish first came into general use in 1946. The original system, a product of the U.S.A., was introduced into this country as the "Dimenso Process." It necessitated the use of special spraying equipment that included an unusual gun equipped with separate liquid feeds for the paint and for the thinners, which entered the gun separately and were mixed after leaving the nozzle.

This special apparatus could be obtained only on hire, but the finish was extremely decorative and really did resemble the deep hammered effect of old pewter. Due to the effect of war-time restrictions, supplies of good-quality metal were still difficult to obtain, and, quite apart from its pleasing appearance, the process had obvious possibilities in obscuring surface defects.

It was not long before a modified paint, which could be applied by means of an ordinary spray gun, appeared on the market. It relied partly on a controlled "leafing" of the aluminium powder present in the paint (the plate-like particles of aluminium becoming somewhat orientated instead of being positioned completely at random) and partly on a degree of coagulation of the varnish medium during the flash-off\* period. This latter effect was obtained by a careful balance of solvent and diluent.

More recently, a different type of paint has been marketed. It contains a silicone compound which is not in true solution but consists of a fine suspension of tiny micelles.† When such a paint is sprayed, each silicone particle repels the varnish surrounding it, so causing a pitting effect. The film obtained, unlike the non-silicone variety, is not continuous, and may well have pin-holes in the centre of the depressions through which the underlying surface can be seen. This defect is known as "cissing" and the earlier type of enamel, containing no silicone, is often referred to as "non-cissing." This sort of finish bears little resemblance to the original hammered-pewter effect, but is extremely useful in camouflaging the surface imperfections of metal. Both varieties can be obtained in stoving or air-drying forms, but whenever possible the former is preferred.

The Post Office accepted hammer finish on apparatus largely because of the difficulty in obtaining an accurate colour-match to the grey glossy enamel previously in use. As various components may be supplied by different manufacturers, variations in colour can be very obvious after assembly.

After the change it was found, however, that matching difficulties remained. At first, attempts were made to produce such a finish similar in colour to the original grey, but they had to be abandoned, and a new standard for colour and pattern was agreed. Sample panels showing the agreed finish were produced and are now available for control purposes.

When production commenced it was soon noticed that great differences both in colour and pattern can result

from variations in spraying technique, even from the same tin of paint. Size of gun nozzle, air pressure, viscosity of paint, and speed of application are among the factors contributing to these variations. Furthermore, the colour and pattern of the finished article may differ considerably according to the angle from which the surface is viewed. It was decided, therefore, that comparisons between samples and the standard should be made by placing them side by side and viewing them from a distance of approximately 4 ft and from a number of angles. Identity of colour and pattern is not obtainable, but two pieces of equipment having the maximum deviation from the standard in opposite senses (e.g. one lighter than the standard and one darker) must not offend the eye.

Earlier specifications demanded a non-cissing enamel applied as a one-coat system to a suitably pre-treated metal, e.g. steel to be hot-dip-phosphated and zinc alloys to be passivated (i.e. with the surface rendered chemically inactive). Unfortunately, the spraying of this type of finish requires a high degree of technical ability, and this is not available at all factories. Some contractors found it impossible to satisfy Post Office requirements and alternative finishes were therefore considered. It was decided to accept silicone-type finishes but, because of the possibility of the pinholes in this type of material giving less efficient protection to the metal, it was thought advisable to insist on the use of an undercoat. Furthermore, since the undercoat may be visible through the pinholes, its colour is required to be similar to that of the final paint film. The current specification permits either a non-silicone finish as a one-coat process, or a silicone-type finish applied over a matching undercoat.

Sometimes metal surface roughness, welding marks and similar imperfections show even through a hammer finish, but, in such circumstances, a "filler-surfacer" can be used as the undercoat, resulting in a much improved surface.

A further difficulty arose because some suppliers found that the required degree of hardness could be obtained only at the expense of flexibility and adhesion. Investigation showed that hot-dip-phosphating improves adhesion only if all the residual salts are thoroughly washed away. If this is not carried out efficiently the adhesion of any paint film subsequently applied may be much worse than that obtained on the bare metal with no pre-treatment.

After a number of alternatives had been tested, it was decided to accept chromated acid-etching primers as an alternative to the hot-dip-phosphate treatment for steel, and these are proving quite satisfactory.

The permitted use of two types of hammer finish has given rise to a number of requests from suppliers for separate standards for the silicone and the non-silicone varieties. It was felt, however, that this would lead to further complications, and if a firm chooses to use the alternative because of its greater ease of application, then their finish must tone acceptably with the existing standard when tested in the manner previously described. This has not apparently proved to be an undue hardship.

A. D. W.

\* Flash-off period—time taken for most of the solvent to evaporate.

† Micelles—colloidal aggregates.

# Coaxial Line Equipment for Small-Diameter Cables

J. C. ENDERSBY and J. SIXSMITH†

U.D.C. 621.395.52 : 621.315.212

The use of transistors has made feasible the development of relatively inexpensive low-capacity coaxial systems suitable for short or medium distances. Small-diameter coaxial pairs are used and the intermediate repeaters can be housed in manholes or buried boxes; surface buildings are only necessary at the terminals. Simple power-feeding arrangements at safe voltages are also a feature of these systems.

## INTRODUCTION

SINCE the introduction of coaxial cables in the main trunk network, developments have been mainly concerned with increasing the bandwidth and circuit-carrying capacity of the line systems. The latest of these wide-band systems (Coaxial-Equipment, Line, No. 8A<sup>1</sup>) is capable of transmitting 2,700 speech circuits in a bandwidth of 12 Mc/s and uses two 0.375 in. diameter (375 E-type) coaxial pairs.

Development has not, however, been entirely confined to evolving wider-band systems. The need for an inexpensive low-capacity link, suitable for short and medium distance telephony, has long been recognized. Some 10 years ago the idea of using small coaxial tubes in composite cables to provide 60–120 circuits over distances of 20–100 miles was examined, but the need for surface-type valve-operated repeater stations and a.c. power feeding made the scheme unattractive.

During the last few years the introduction of reliable high-frequency transistors has made it possible to design repeaters that could be housed in manholes or in special buried boxes. These repeaters only require simple d.c. power-feeding arrangements, and as a result an economical small-tube system became a practical proposition. The first such system, developed and installed for the Post Office by Standard Telephones and Cables, Ltd., and now carrying telephone traffic between Eastbourne and Hastings, is described in the following paragraphs. References are also made to a similar system manufactured by the Automatic Telephone & Electric Co., Ltd., to a Post Office standard system, and to possible future developments.

## GENERAL DESCRIPTION

The line equipment for the Eastbourne–Hastings small-diameter coaxial-pair cable uses transistors throughout to the complete exclusion of thermionic valves. Intermediate repeaters are housed in joint boxes at intervals of  $4,000 \pm 220$  yards and d.c. power is fed over the conductors of the coaxial pairs. Two systems are provided, using pairs 1–4 of a 6-pair 163A-type coaxial cable. Separate coaxial pairs are used for each direction of transmission, and each system provides 300 telephony circuits assembled in five supergroups in the frequency range 60–1,300 kc/s.

### Line Terminal Equipment

The line terminal equipment is of mixed 51-type<sup>2</sup> and 56-type construction, mounted on 9 ft rack-sides; one rack-side has space for the line equipment and power circuits for two systems (600 telephony circuits). A

† Main Lines Development and Maintenance Branch, E.-in-C.'s Office.

second rack-side has been designed to meet special Post Office requirements and includes panels that give monitor and test facilities. One line-equipment rack-side, equipped with two systems and feeding power to 15 dependent repeaters, consumes some 200 VA and can be operated either from 18–24-volt d.c. supplies or from a.c. mains.

### Dependent Repeater Equipment

Dependent repeaters are housed in water-tight containers that are basically cast-iron pipes approximately 1 ft in diameter and 4 ft 6 in. long. Each container, which takes repeaters for two systems (four coaxial pairs), stands erect and partly buried in the floor of a joint box so that approximately 18 in. of the container protrudes. The lower end of the container is sealed, and access to the repeaters is obtained by means of a removable lid secured by a clamp. The underground cables enter by sealed glands near the top of the container.

A small double-sided framework on a sliding mechanism supports the jack-in type high-frequency units and power units; the units for one system occupy one side of the framework (Fig. 1). Connexion between

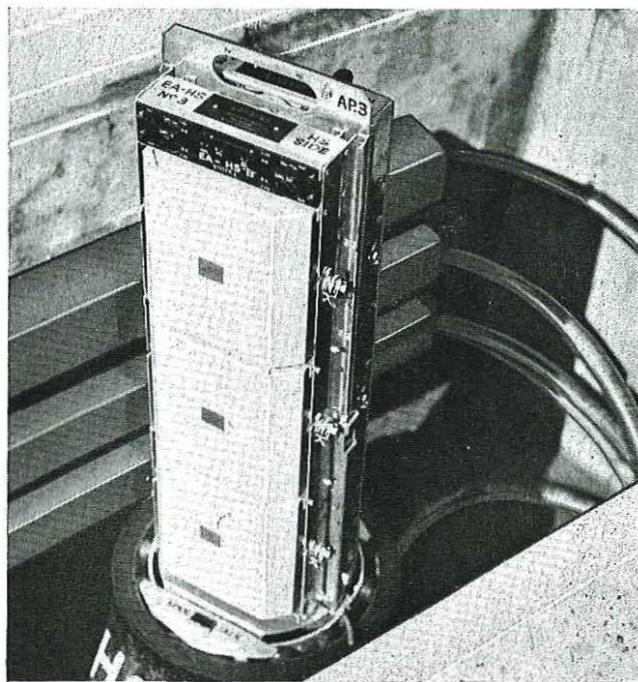

FIG. 1.—DEPENDENT REPEATER EQUIPMENT IN RAISED POSITION

the underground cables and the repeater is by flexible hanging leads in neoprene sleeves, enabling equipment to be raised and examined without interrupting service. The container is suitable for burying in open ground and has the advantage that repeaters are placed well below ground level, so that ambient-temperature variations are smaller than in surface stations. The housing can be

fitted with a Schraeder valve to enable pressure checks of the sealing to be made.

### 163A-Type Coaxial Pair

The 163A-type coaxial pair has copper conductors. The outer conductor is essentially a copper tape, with crimped edges, formed longitudinally round the expanded-polythene dielectric and with the edges of the tape butted. Two steel tapes are wrapped helically round the outer conductor to reduce crosstalk at lower frequencies and to add mechanical strength to the cable. The inner diameter of the outer conductor is 0.163 in., and at 1 Mc/s the cable attenuation is approximately 10 db/mile, the characteristic impedance being approximately 66 ohms. The coaxial pairs are insulated from each other by a lapping of polythene adhesive tape.

The Eastbourne-Hastings cable has six coaxial pairs laid round a centre group of five polythene-insulated 10 lb/mile symmetrical pairs.

### SYSTEM DESIGN

A block schematic diagram of the terminal equipment is shown in Fig. 2, while Fig. 3 shows the dependent repeater equipment in a similar manner.

The system is of the regulated type, i.e. it includes automatic level regulation to compensate for attenuation changes caused by variations in cable temperature. Level regulation is effected at alternate dependent repeaters; the principles of such systems have already been adequately described<sup>1, 3</sup>. The present system, however, differs from other coaxial systems in employing transistors throughout instead of thermionic valves. The regulating circuits, in addition to correcting level changes due to cable-temperature variation, also absorb the effects on transmission level of the small tolerances in repeater-section length ( $\pm 220$  yards).

The system is designed to meet C.C.I.T.T.\* noise

\* C.C.I.T.T.—International Telephone and Telegraph Consultative Committee.

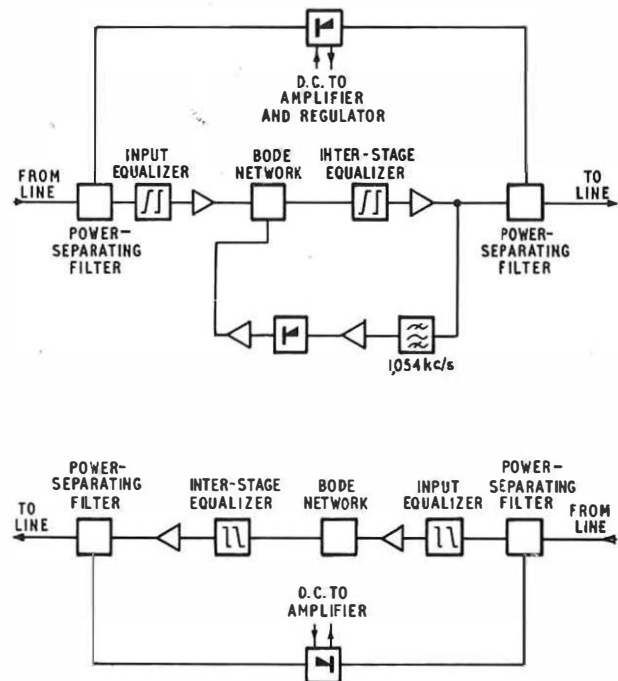
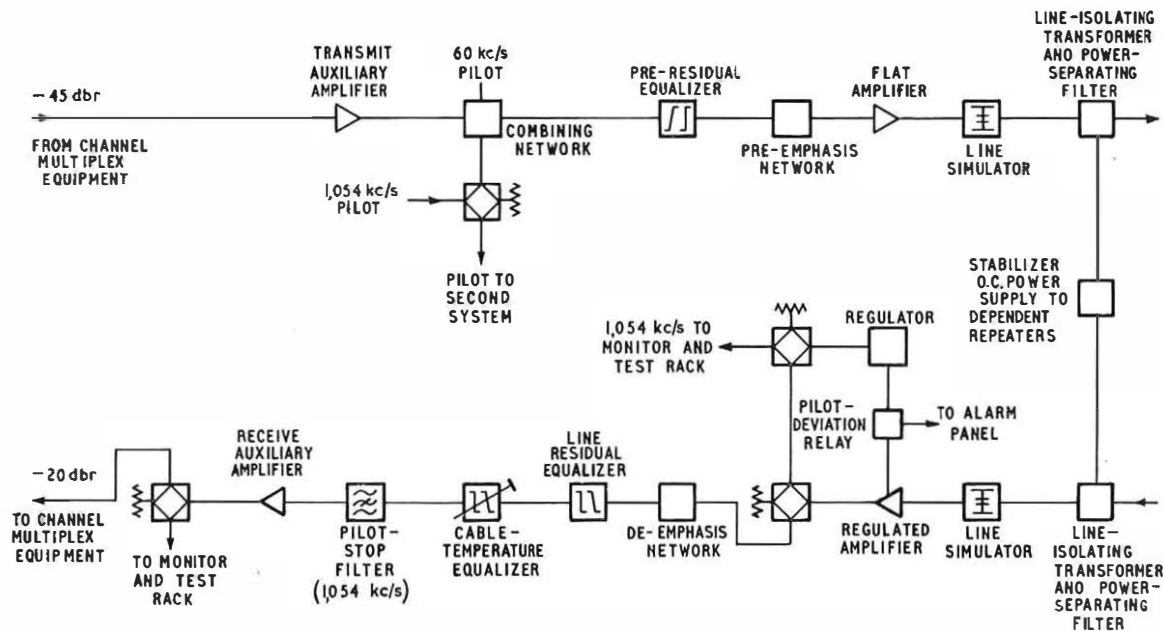

FIG. 3—SIMPLIFIED BLOCK SCHEMATIC DIAGRAM OF DEPENDENT REPEATER

limits of 3 pW/km under the conditions specified for the hypothetical reference circuit<sup>4</sup> of 2,500 km.

The regulating pilot is 1,054 kc/s and it falls within the small frequency band separating supergroups 4 and 5. It is generated by main and standby oscillators with automatic change-over in the event of failure. The national 60 kc/s frequency-synchronizing pilot is also transmitted, and a stabilizer on the monitor rack ensures that this pilot is sent to line at a constant level so that, when it is monitored at the receiving end, it gives a reliable indication of the performance of the link. The



Notes: 1 dbr—relative level, i.e. the ratio, in decibels, of the power at a point in a line to the power at the origin of the circuit (usually the 2-wire point).  
2 The line levels from each repeater are nominally -24 dbr at 60 kc/s and 1,300 kc/s; pilot levels are 10 db below channel test level

FIG. 2—SIMPLIFIED BLOCK SCHEMATIC DIAGRAM OF TERMINAL EQUIPMENT

received level of both pilots is continuously displayed on meters on the monitor rack. Recording decibelometers that give a permanent record of the received pilot levels are provided.

The temperature coefficient of attenuation of the cable is not constant throughout the frequency spectrum of 60–1,300 kc/s, being greater at 60 kc/s than at other frequencies. Consequently, on long routes, cumulative errors may occur when the cable is at a temperature other than the mean for the territory. A manually-operated cable-temperature equalizer is therefore incorporated in the system and compensates for this effect.

#### Emphasis and De-emphasis

So that the system can operate with optimum signal-to-noise ratios, the send-line terminal is arranged to transmit signals to line with a flat gain over the major part of the band. This flat characteristic is modified slightly at frequencies close to the pilot frequency (1,054 kc/s) by means of a pre-emphasis network. An inverse network in the receive terminal restores the signal levels to their original relationship.

#### Amplifiers

The basic amplifier stage used throughout employs two transistors in grounded-base push-pull configuration with input and output transformers (Fig. 4). This

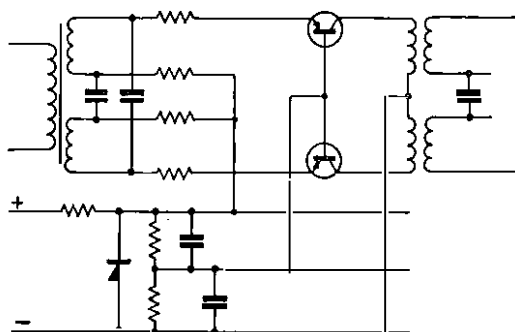

FIG. 4—BASIC AMPLIFIER STAGE

arrangement gives a linear input-current/output-current relationship, and in complete amplifiers employing a number of these stages only small amounts of negative feedback are used, mainly to improve output impedances.

#### Dependent Repeaters

The dependent repeater provides the gain and equalization required for one line section (approximately 7 db gain at 60 kc/s and approximately 27 db gain at 1,300 kc/s). The repeater (Fig. 3) consists of an input equalizer and two amplifiers each comprising two of the stages shown in Fig. 4. The amplifiers are coupled by a Bode-type regulator network<sup>6</sup> plus a second equalizer. The two equalizers give the required shape to the gain/frequency characteristic.

Each unregulated repeater has its Bode-regulator network terminated in 510 ohms and in this condition the network has a uniform loss of 5 db from 60–1,300 kc/s. At regulated points, however, the network is terminated in a thermistor, which is the loss-controlling element. Heater power for the thermistor is derived from the 1,054 kc/s pilot at the repeater output. Regulated dependent repeaters have a control ratio of approximately 4 : 1. Regulation at a dependent repeater is normally

carried out in one direction of transmission only, the signals for opposite directions being regulated at each successive repeater.

#### Terminal Repeaters

The auxiliary, transmit and receive flat amplifiers each comprise three basic stages with a small amount of negative feedback between the last two stages to improve the output impedances; the gain of each amplifier is 25 db. The receive line amplifier at the terminal stations is electrically similar to a regulated dependent amplifier although it differs physically to make it suitable for mounting on a 56-type rack-side, and in addition the control ratio of the amplifier and regulator is of the order of 10 : 1 so as to provide the increased control required by the last station in a regulated line section.

#### POWER SUPPLIES

##### Safety Considerations

The small amounts of power consumed by transistor repeaters have made it possible, for the first time, to employ constant-current power feeding at safe voltages on coaxial-cable links, thus permitting a major simplification of power-feeding arrangements. Complicated power-switching procedures, designed to protect personnel from high voltages, and expensive standby power arrangements for dependent repeaters are unnecessary. Power-separating circuits are also simpler. It was, nevertheless, necessary to fix an upper limit to voltages and line currents in the interests of safety, and the limits decided were as follows:

- (a) The voltage between an inner conductor and earth should not exceed 250 volts.
- (b) The current through a 2,000-ohm resistor between any conductor and earth should not exceed 50 mA, even under fault conditions.
- (c) The time taken for the current stabilizer to reduce current to 50 mA when power is first switched on to the line, or the power unit is loaded with 2,000 ohms, should not exceed 250 ms.

##### Terminal-Station Power Circuits

A block schematic diagram of the power circuits on the terminal rack is shown in Fig. 5. The conversion of a.c. mains to outputs of 20 volts d.c. and 21 volts d.c. anticipates the provision of coaxial line systems of this type in stations where power supplies for transistor equipment only are available.

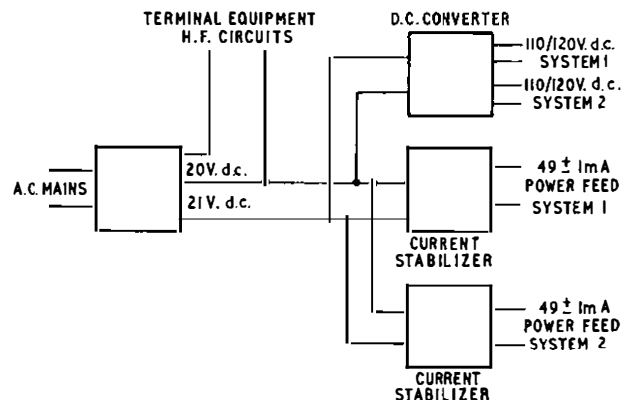

FIG. 5—BLOCK SCHEMATIC DIAGRAM OF TERMINAL-EQUIPMENT POWER-SUPPLY ARRANGEMENTS



The power-supply unit for the supervisory circuits provides a nominal 120-volt d.c. output by means of a single-transistor switch in a transformer-coupled circuit.

The d.c. converter and current stabilizer is capable of feeding 15 dependent stations and the current is stabilized at  $49 \pm 1$  mA. The voltage required to supply 15 stations, however, exceeds the safety limits imposed by the Post Office, and the maximum number of dependent stations that can be fed using the permitted 250-0-250 volts d.c. is 12. Each repeater section accounts for a voltage drop of some 40 volts.

The stabilizer is operated from 21 volts d.c. Uni-directional pulses are applied to the primary of a step-up transformer to yield a high-voltage secondary current which, after rectification and smoothing, is suitable for feeding to line. The frequency of the pulses is constant at 1 kc/s, under the control of very short pulses derived from a 1 kc/s square-wave oscillator. The duration of the pulses is, however, governed by voltages from comparison circuits that monitor the current to line. These voltages change with changing line current, lengthening the duration of the applied pulses when the value of the line current falls and shortening the duration of the applied pulses when it rises.

#### Dependent-Repeater Power Circuits

A schematic diagram of the power-separating circuits at dependent repeaters is shown in Fig. 6. The current is

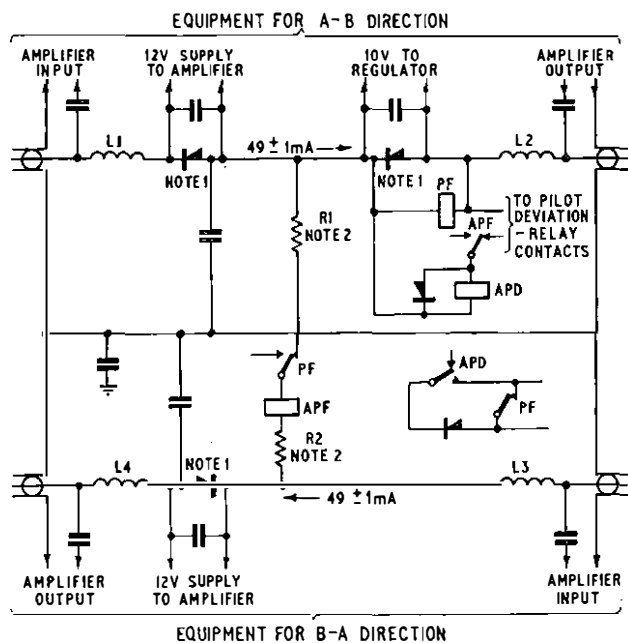

Notes: 1 Zener diode.  
2 The sum of the values of R1 and R2 equal the resistance of the inner conductor to the end of the power-feeding section.  
FIG. 6—DEPENDENT REPEATER: POWER, ALARM AND SUPERVISORY CIRCUITS

applied in series with the amplifiers and regulators, but a Zener diode in parallel with each unit maintains a constant supply-voltage and prevents damage to the units by line surges.

#### SUPERVISORY AND ALARM CIRCUITS

##### Dependent Repeaters

The alarm and supervisory circuits of a dependent repeater are shown in Fig. 6. Relay PF is operated when

power is on the circuit. If power fails relay PF releases and short-circuits the alarm and supervisory pairs. Under fault conditions, e.g. a broken inner conductor, the power-fail condition is applied at all succeeding repeaters to the end of the power-feeding section. Power is maintained at stations up to the one preceding the fault, however, as at this station relay PF releases and loops the inner conductors, and a contact of relay APF disconnects the pilot-deviation circuit preventing the simultaneous operation of relays APF and APD.

A 1,054 kc/s pilot failure or a deviation in level by more than  $\pm 4$  db operates relay APD from pilot-deviation contacts provided on regulated repeaters only. A contact of relay APD connects a rectifier across the alarm and supervisory pair. The sense in which the rectifier is connected to the alarm pairs identifies the direction of the pilot that has failed. Location of faults is made by resistance-bridge methods. In general it is necessary to locate pilot failure from the pilot-sending terminal and power failure from both terminals.

#### Terminal Stations

At terminal stations, alternate positive and negative pulses of some seconds duration are applied to the alarm pair. These pulses are monitored by relay circuits that are sensitive to large changes in line impedance and respond distinctively to the three basic alarm conditions:

- (a) alarm pair looped,
- (b) alarm pair looped via a rectifier, and
- (c) alarm pair looped via a rectifier connected in reverse sense to the one provided under (b).

The detection of an alarm condition causes a suitably-labelled lamp to glow and operates the station alarms.

#### TEST EQUIPMENT

A portable transistor-type inter-supergroup pilot-measuring set powered by batteries has been designed, and suitable level-measuring points (and also power-voltage check points) are provided at dependent repeaters. The set also measures the 1,054 kc/s regulating pilot. There is also a portable amplifier change-over unit that allows amplifiers at dependent repeaters to be changed without interruption to service. This set can also be used as a test jig when servicing amplifiers.

As an aid to locating intermittent faults without interfering with service on a route, a small 308 kc/s transistor oscillator has been designed that may be placed inside a dependent-repeater container and its output applied to the system at a level-measuring point. The oscillator may be moved from repeater to repeater along a route until its output, monitored at a receiving terminal, is no longer subject to intermittent interruption. The approximate position of the trouble is then known.

A portable transistor-type telephone set is used for communicating with the terminals from dependent-repeater points and, for the short Eastbourne-Hastings system, a 2-wire circuit is used. The set has a loudspeaker that also serves as a microphone. The circuit is changed over from 'listen' to 'speak' by operating a non-locking key. D.C. loop signalling under the control of a push-button is used to call the terminal stations.

#### BRIGHTON-CHICHESTER SYSTEM

The system manufactured by the Automatic Telephone & Electric Co., Ltd.,<sup>6</sup> and installed between Brighton and Chichester differs in several respects from the one just

described. The intermediate repeaters are housed in nickel-iron box-type containers that can be placed either in existing manholes or in footway boxes.

The cable used is the 163B-type, which has a characteristic impedance of 75 ohms and a slightly higher attenuation than the 163A-type. In spite of this, repeater spacing is maintained at 4,000 yards and regulation is only effected at every fourth dependent repeater. A novel feature of the control system is the provision of an external test socket that may be cabled to a point remote from the manhole, enabling transmission and power measurements to be made without opening the repeater container; a portable transistor-type level-measuring set and pilot-level indicator are provided. This test point also gives access to the speaker circuit, for which a portable amplified telephone is provided.

The terminal transmission, supervisory and power-feeding equipment for two systems is mounted on one rack-side.

#### POST OFFICE STANDARD SYSTEM

For future installations an overall design specification has been prepared by the Post Office Engineering Department, making use of the experience gained during the present field trials and incorporating later recommendations of the C.C.I.T.T. An attempt has been made in this design to combine reliability of operation with simplicity and ease of maintenance.

The cable for new installations will be the 174-type (75-ohm), samples of which have been made by a number of contractors. Various methods of supporting the inner conductor are used. Although essentially an air-spaced cable, a thin continuous layer of insulant exists between the inner and outer conductors to guard against the possibility of contact between conductors due to kinking. The attenuation of the cable is of the order of 8.5 db/mile at 1.0 Mc/s.

The dependent repeaters, spaced at 6,300-yard intervals, will be installed in a newly designed container (Repeater Equipment Box No. 1).

It is hoped that the first standard system, between Widemouth and Tavistock and forming part of the TAT-3 link,<sup>7</sup> will be ready for service in 1963.

#### POSSIBLE FUTURE APPLICATIONS

The next 10 years should see the installation of many of the standard systems as short links between large towns and as spur routes; other possible applications, such as radio-link extensions and perhaps wide-band data-transmission circuits, can be envisaged.

Junction cables between exchanges in high telephone-density areas are costly and could perhaps be superseded by small-diameter coaxial "audio-audio" links using composite rack-sides with built-in signalling facilities for the terminal equipment. The capacity of existing duct routes would be increased at the cost of small additional space requirements within the exchange. These requirements would be partly offset by a decrease in the space required on the main distribution frame.

There may also be a challenge to existing methods of providing trunk routes between large cities because multiple small-tube cables carrying systems of simple design might prove preferable to single large-capacity complex systems. On multi-system routes the loss of a single small-tube system would not be catastrophic and provision of spare lines could be both simple and liberal.

#### ACKNOWLEDGEMENTS

The authors wish to acknowledge the co-operation of Standard Telephones and Cables, Ltd., and the Automatic Telephone & Electric Co., Ltd.

#### References

- <sup>1</sup> BORDISS, H. K., and DAVIES, A. P. A 12 Mc/s Coaxial Line Equipment—C.E.L. No. 8A. *P.O.E.E.J.*, Vol. 54, p. 73, July 1961.
- <sup>2</sup> HARRIS, E. T. C., and SPRATT, C. J. An Improved Form of Mechanical Construction for Transmission Equipment—51-Type Construction. *P.O.E.E.J.*, Vol. 51, p. 197, Oct. 1958.
- <sup>3</sup> COLLIER, M. E., and SIMPSON, W. G. A New 4 Mc/s Coaxial Line Equipment—C.E.L. No. 6A. *P.O.E.E.J.*, Vol. 50, p. 24, Apr. 1957.
- <sup>4</sup> C.C.I.T.T. Green Book, Vol. III bis, Section 3.1.1(c), p. 51.
- <sup>5</sup> BODE, H. W. A Variable Equalizer. *Bell System Technical Journal*, p. 229, Apr. 1938.
- <sup>6</sup> HELLIWELL, B. S., and WILKINSON, F. A Small-Diameter Coaxial System. *A.T.E. Journal*, Vol. 16, p. 13, Jan. to July 1960.
- <sup>7</sup> A Proposed New Cable System Direct to U.S.A.—TAT-3. *P.O.E.E.J.*, Vol. 53, p. 169, Oct. 1960.

## Book Review

"Static Relays for Electronic Circuits." Edited by R. F. Blake. Reinhold Publishing Corporation, New York, and Chapman & Hall, Ltd., London. viii + 198 pp. 168 ill. 63s.

The book is based on a Static Relay Symposium sponsored by a U.S.A. military organization. In 17 chapters by different authors the static relay is treated as an entity which can be packaged as an interchangeable and replaceable unit for general use. As such it is more familiar and useful to control-system than to communication engineers, and, indeed, even some of the items common to both are known by different names, e.g. transwitch for pnpn transistors.

One chapter states at some length the requirements of static relays; included is not only a high impedance in series with a load when the circuit is open and a high conductance when the circuit is closed but also a snap action and other features further to simulate relays with metal contacts. When to these requirements are added

isolation between input and output and, in some cases, no power supplies other than the operating input, some quite complicated circuit arrangements result. It is recognized that static relays compete with mechanical relays in such circumstances only when they are required to have some feature not obtainable mechanically, such as a very high speed of operation or the ability to withstand vibration or high acceleration.

A wide range of basic switching elements and their characteristics are described. Circuit configurations to simulate most types of electromechanical relays and applications are given, and two chapters are included on bistable magnetic amplifiers. Solid-state "contacts" for various control-switching purposes are described, together with power switches. There is a chapter on tunnel diodes as amplifiers and switches.

The book is practical and easy to read, and is commended to power and control-system engineers for the quantity of useful information collected in one volume, and to telephone-switching engineers for general interest.

T. H. F.

# Power Units for Use at Subscribers' Premises

M. B. MOORE, A.M.I.E.E.†

U.D.C. 621.311.62 : 621.395.721.1

A series of small mains-operated power units has been developed to operate telephone equipment at subscribers' premises. The characteristics of the power units and the considerations that led to their development are briefly outlined.

## INTRODUCTION

SOME types of subscribers' telephone equipment, e.g. small private branch exchanges, are usually operated by direct current drawn from wet or dry primary-cell batteries or secondary-cell batteries, and maintenance costs are disproportionately high. The use of power leads from public telephone exchanges as an alternative source is wasteful of line plant. A series of simple mains-operated power units has, therefore, been developed particularly for use at small private branch exchanges and similar installations.

## DESCRIPTION

The power units consist essentially of a mains transformer associated with a rectifier element, a choke and an electrolytic capacitor; a typical circuit is shown in Fig. 1. The input fuse, which is of a surge-resistant type

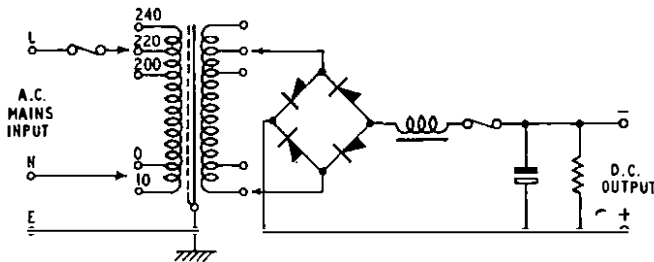

FIG. 1—TYPICAL CIRCUIT OF A POWER UNIT

that withstands initial surges when the unit is switched on, gives adequate protection against faults that might develop within the unit. The output fuse protects the rectifier from damage in the event of a breakdown of the capacitor. Tappings on the transformer cater for various input voltages and, on the secondary winding, for variations of rectifier-element characteristics as well as providing compensation for aging of the rectifier elements.

Economically, the broadest possible limits of voltage regulation are desirable for units of this type, and the designed output-voltage excursions (at nominal input voltage) between no load and full load are the maxima that can be tolerated by the equipment to be served. Fig. 2 shows the relationship between load current and output voltage of a typical power unit. The section AB represents the load of the resistor, and the section BC is the useful load that can be drawn from the unit. The

† Subscribers' Apparatus and Miscellaneous Services Branch, E.-in-C.'s Office.

<sup>1</sup> HALLIDAY, C. M., and LIDBETTER, E. J. A New Small Cordless P.M.B.X. Switchboard. *P.O.E.E.J.*, Vol. 54, p. 22, Apr. 1961.

<sup>2</sup> AKESTER, K. M. A Switching Unit for Use with 700-Type Telephones—Plan Set N625. *P.O.E.E.J.*, Vol. 53, p. 242, Jan. 1961.

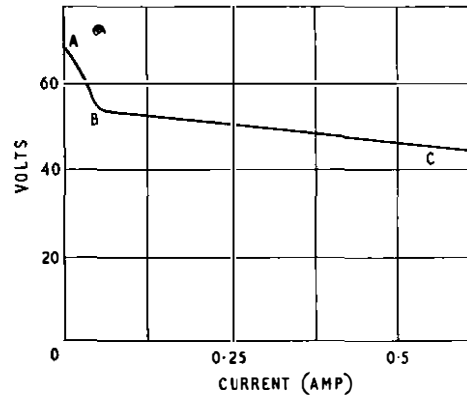

FIG. 2—OUTPUT-VOLTAGE/LOAD-CURRENT CHARACTERISTIC

resistor provides both an economical means of improving the regulation of the unit and a leakage path for any charge that might otherwise be left on the capacitor when the supply is disconnected. The output characteristics of the power units are, in general, such that the units are unsuitable for battery charging.

A number of units have already been developed, including two intended for use with the new cordless lamp-signalling switchboards.<sup>1</sup> These units have full-load outputs of 0.5 amp and 1 amp at 45 volts, and a no-load output of 55 volts. Their output is smoothed so that the ripple-noise voltage is below the permissible maximum of 2 millivolts.

A further power unit has been designed for use with a Plan Set N625.<sup>2</sup> There is no transmission bridge in this telephone switching apparatus to filter some of the ripple noise, and the maximum ripple voltage on the unit is, therefore, limited to 0.75 millivolts. Its output voltage of 10 volts at 0.25 amp rises to 12.25 volts with no load.

A series of units with full-load outputs of 0.33 amp, 1 amp and 2 amp at 22 volts, and a no-load voltage of 28 volts, has also been designed for use with the older types of indicator switchboards serving up to 65 lines. The output of these units is smoothed to give a ripple voltage of less than 2 millivolts.

The principal characteristics of the power units that have so far been developed are summarized in the table.

## Ringling Converter

All the power units, except that designed for use with the Plan Set N625, include space and fixing holes for a small self-contained mains-driven ringling converter so that power ringling can easily be provided if required (Fig. 3).

## Mounting Arrangements

The mounting arrangements for the 45-volt power units are such that the units match other ancillary equipment associated with the cordless lamp-signalling switchboards, i.e. the connexion box and auxiliary apparatus units, which are wall-mounted. Fig. 4 shows

Characteristics of Power Units for Use at Subscribers' Premises

Type of Unit	Output Voltage		Maximum Output Current (amp)	Subscribers' Equipment
	Open Circuit	On Full Load		
Power Unit No. 50A	55	45	0.5	} Small cordless lamp-signalling P.M.B.X.s
Power Unit No. 51A	55	45	1.0	
Power Unit No. 53A	12.25	10	0.25	Plan Set N625
Power Unit No. 55A	28	22	0.33	} Certain non-multiple P.M.B.X.s
Power Unit No. 56A	28	22	1.0	
Power Unit No. 57A	28	22	2.0	

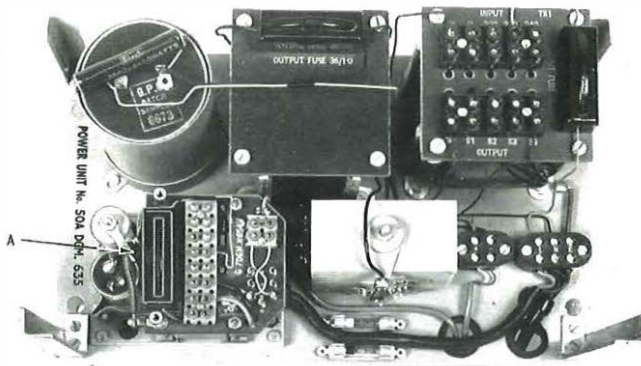

A—Ringing Converter  
FIG. 3—POWER UNIT NO. 50A

how the ancillary equipment and the power unit are arranged above the connexion box, which has a less deep cover, so permitting adequate ventilation of the power unit via the louvres in the bottom of the power-unit cover. Further auxiliary units may be added as required above the units shown.

The units have an elephant-grey egg-shell finish, which is the standard for power and ancillary equipment for use at subscribers' premises.

**Mains Failure**

The power units do not give a special indication or alarm in the event of mains failure and in such circumstances inter-extension working will be interrupted on switchboards operated from these units. Calls in progress from extensions to the public exchange will not, however, be interrupted, and exchange calls can be handled by the operator or connected to nominated extensions, and the subscriber will not be isolated. The power units are, however, unsuitable for those subscribers, e.g. fire, police and hospital services, who cannot tolerate restricted working during a mains failure and who require standby-battery facilities. For such subscribers other methods of providing a power supply must be used.

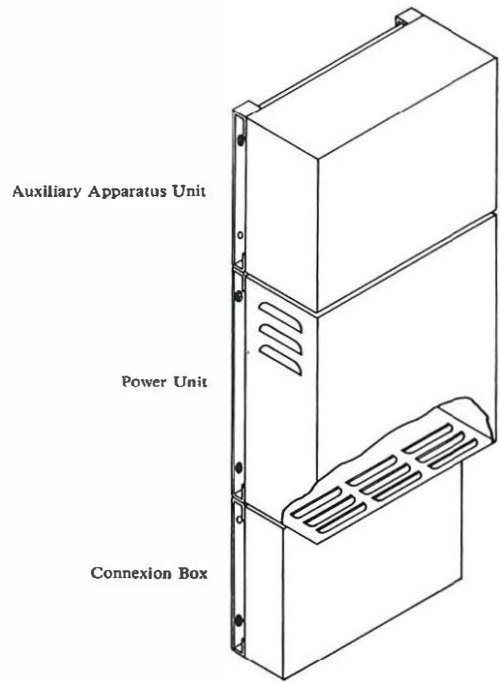

FIG. 4—MOUNTING ARRANGEMENTS FOR POWER UNIT AND OTHER ANCILLARY APPARATUS FOR A SMALL CORDLESS SWITCHBOARD

**FUTURE DEVELOPMENT**

Power units of greater output will be produced to meet the requirements of larger switchboards, and it is already apparent that 45-volt units with outputs of 2 amp and 4 amp will be required, and these are under development. Consideration is also being given to the development of power units for small P.A.B.X.s and a new house-exchange system.

**ACKNOWLEDGEMENTS**

The power units described were developed by the Post Office in conjunction with Messrs. Harmer & Simmons, Ltd., and the Westinghouse Brake & Signal Co., Ltd., whose co-operation in the building of prototype models is gratefully acknowledged.

# Signalling System A.C. No. 9

J. V. MILES and D. KELSON, A.M.I.E.E.†

U.D.C. 621.395.385.4

A new 1 v.f. 4-wire connected signalling system (S.S.A.C. No. 9) has been developed for completing the trunk-mechanization program and for subscriber trunk-dialling applications. The new signalling system has superseded S.S.A.C. No. 1 for the provision of voice-frequency signalling facilities on the national trunk telephone network. This article describes the principal features and requirements of the new design and includes the facilities and details of the v.f. receiver and buffer amplifier.

## INTRODUCTION

PRIOR to the development of the new voice-frequency signalling system, S.S.A.C. No. 9, inband voice-frequency signalling on the inland network was given by the S.S.A.C. No. 1 system.<sup>1</sup> While the S.S.A.C. No. 9 system gives the same basic facilities as the S.S.A.C. No. 1 system, which it now supersedes, advantage has been taken of modern thought and trends in the inband voice-frequency signalling art, which have resulted in the new signalling system being much less expensive, more compact and smaller in physical dimensions, and simpler than the older system. Opportunity has also been taken to include some additional facilities and to incorporate features designed to eliminate certain limitations of the S.S.A.C. No. 1 system.

The relative simplicity and reduced costs have, in general, been achieved by the use of a single signalling frequency (2,280 c/s) with the signalling equipment inserted in the 4-wire circuit, compared with the two signalling frequencies (600 and 750 c/s) and signalling equipment connected in the 2-wire, as used for the S.S.A.C. No. 1 system.

## FEATURES OF THE NEW DESIGN

### *Connexion and Mounting Arrangements of 4-wire/2-wire Termination and Line-Signalling Equipment*

For association of the signalling equipment with a circuit, the 4-wire audio ends of the transmission circuit are cabled to the S.S.A.C. No. 9 relay-set racks in the trunk automatic exchange. The signalling equipment is 4-wire connected as shown by the block-schematic diagram given in Fig. 1. When, however, the circuits are switched on a 2-wire basis it is necessary to provide a 4-wire/2-wire termination in the circuit. The hybrid transformer used for this purpose in the 2 v.f. system forms part of the transmission equipment but for the 1 v.f. system a new transformer (Transformer No. 3/326A) has been designed.

In the overall economy of the design all the items that are associated with the line at either end of a unidirectional S.S.A.C. No. 9 circuit are contained on a single base-plate of a standard 2,000-type relay-set. This includes the transformer used for the 4-wire/2-wire termination, which was designed to take the position of two 3,000-type relays and is fitted with the signalling equipment on the exchange relay-set mounting-plate.

### *Tandem Dialling and Interworking on a Link-by-Link Basis*

Subscriber trunk-dialling tandem routings will, in the

† Telephone Exchange Systems Development Branch, E.-in-C.'s Office.

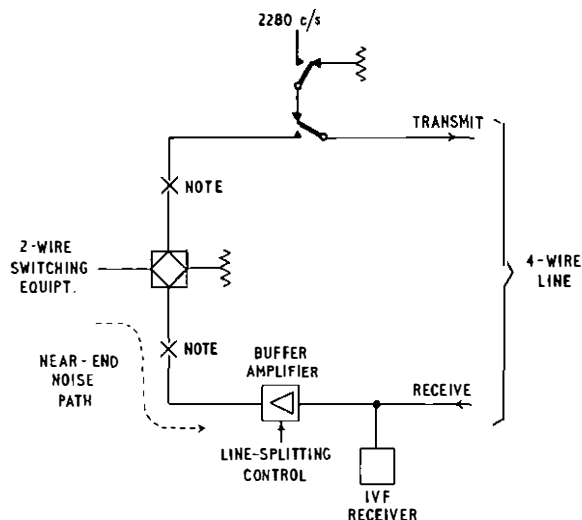

Note: Connexion points for echo suppressor, when required.

FIG. 1—SIGNALLING EQUIPMENT CONNECTED IN THE 4-WIRE LINE

future, be carried by a new 4-wire-switched transit network but S.S.A.C. No. 9 will not be used for this. While most of the applications of S.S.A.C. No. 9 will concern circuits that are used only to provide a direct route to the terminal zone centre some tandem routings will, however, be required with this system. Where a tandem routing is involved S.S.A.C. No. 9 uses the link-by-link method of signalling. No through-signalling using end-to-end v.f. signals is employed, so that, for either a direct routing or a tandem routing, it is necessary to split the line at the 4-wire v.f. signal-receiving point and confine the signals that the system uses to the individual link within which a v.f. signal originates. Any signal requiring end-to-end recognition on a tandem connexion involves a d.c. signal repetition at the tandem switching point.

In the absence of the discriminating requirements which fully-flexible through-signalling arrangements would have entailed, the circuit design is less complex than it otherwise would have been.

### *Echo Suppressors Associated with a Circuit using V.F. Signalling*

An echo suppressor, when performing its designed function, must permit transmission in only one direction of the two possible directions provided by the transmission path of a 4-wire circuit. To take full advantage of the possibilities of a 4-wire connected v.f. signalling system simultaneous signalling in the two directions is desirable. If for transmission considerations an echo suppressor is present in a circuit so that it prevents signalling in both directions simultaneously then the signalling has to be delayed in one direction of transmission, with a resultant complexity of the signalling equipment.

Furthermore, in the presence of speech or tone in one direction, an echo suppressor can effectively block the transmission path required for signalling in the reverse direction. This causes particular difficulty when a tone

originating from a continuous source in the switching system (e.g. number-unobtainable tone) exercises control over the echo suppressor. In a 2-wire connected signalling system it is generally necessary to include means within the signalling relay-set to overcome this difficulty. In S.S.A.C. No. 1 the transmission path is interrupted to allow echo suppressors to restore from the effects of continuous tone in the backward direction, thus permitting forward v.f. signals to function correctly.

Maximum advantage can be obtained if the design of the signalling system offers the opportunity of connecting the echo suppressor in the 4-wire line where the suppressor cannot in any circumstances affect the v.f. signalling path. Link-by-link signalling permits this if the echo suppressor is connected at the position shown in Fig. 1, from which it can be seen that the suppressor insertion points are not within the v.f. signalling path; these insertion points are connected to U-points on the shelf jack of the outgoing relay-set.

The number of circuits in which it is necessary to connect echo suppressors is a small percentage of the total number of inland circuits, and the allocated U-points are wired out to a rack connexion block only from those shelf-jack positions nominated on a proportional basis; the cabling from the rack is provided as required.

#### Operator Access

In general, operators will gain access to the S.S.A.C. No. 9 circuits using loop-disconnect pulsing circuits via selector levels. Provision has been made, in certain circumstances, for direct access to S.S.A.C. No. 9 circuits from a manual board over 3-wire junctions: a loop-disconnect pulsing relay-set, having a P-wire controlled relay for guarding, can be connected, via the 3-wire junction, directly to the S.S.A.C. No. 9 auto-auto relay-set at the trunk exchange. Direct-access facilities on a sleeve-control basis are not provided. A typical routing used by an operator to gain access to the S.S.A.C. No. 9 circuits via a selector level is shown in Fig. 2.

#### SIGNALLING FACILITIES

##### Facilities Equivalent to Those Provided by S.S.A.C. No. 1

In catering for seizure, digital pulsing and forward clearing, and for called-subscriber answering, backward clearing and backward busying, S.S.A.C. No. 9 provides facilities equivalent to those provided by S.S.A.C.

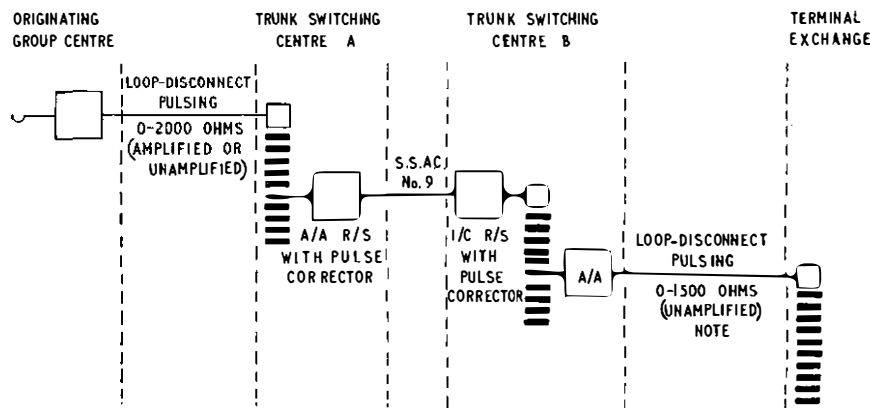

Note: 0-2,000 ohms (unamplified) where the terminal exchange equipment is 2,000-type.  
FIG. 2—TYPICAL OPERATOR ROUTING OVER S.S.A.C. No. 9 CIRCUIT

No. 1. For these purposes, the new system uses a single signalling frequency of 2,280 c/s which is transmitted as indicated in the table. The table also shows the recognition times for the different signals.

Signals used for S.S.A.C. No. 9

Direction of Transmission	Signal	Duration of Signal Transmission (in ms)	Recognition Time for Signal Transmission (in ms)
Forward	Seizure Element of digit pulse-train	50-80	20-35
	Forward clear	40-70 700 min.	20-30 400-600
Backward	Answer	200-300	100-150
	Clear back	200-300	100-150
	Release guard	650 min.	400-600
	Backward busy (Note)	Continuous	35 max.

Note: On a bothway circuit the backward busy signal is transmitted for a minimum period of 1,650 ms. This signal is recognized by the incoming equipment at the distant end as a seizure signal; after 120-180 ms this seizure is cancelled but the associated outgoing equipment remains busy.

#### Signal Sending Level

The maximum signalling level allowed decreases as the signalling frequency increases, due to channel-to-channel crosstalk considerations of the transmission systems. A lower signalling level is therefore used for the new 1 v.f. system than for the older 2 v.f. system. In the new system the signals are transmitted at a sending level of  $-6 \pm 1$  db with reference to a point of zero relative level. Therefore, from the  $-4$  dbr point of the 4-wire circuit, at which the signal sending circuit is associated with the line, the signals are transmitted at the nominal signal level of  $-10$  dbm.

#### Release Guarding and Repeat Clearing

In general, the S.S.A.C. No. 9 circuits will be available from selector-level outlets and from this aspect it is important that a circuit should not remain continuously available for traffic from the associated selector-level outlet when a failure has rendered the circuit unworkable; this is particularly so when the calls have been originated by subscribers who have subscriber trunk-dialling facilities. To meet such circumstances the system design includes a sequenced release guard using the release-guard signal shown in the table. Using this sequence a signalling failure is detected when the circuit is cleared down.

When a forward-clear signal has been recognized by the incoming equipment and has ceased, a release-guard signal is returned to the outgoing equipment as an acknowledgement signal. At the outgoing equipment the selector-level outlet remains busy until the release-guard signal has been recognized and has ceased. When a circuit which is in service develops a fault condition such that a release-guard sequence will be prevented it may be taken into use by a call which will be lost, but this will be the only call

lost as thereafter the faulty circuit remains continuously guarded. Following the failure of the release-guard sequence on a circuit the outgoing relay-set gives a delayed visible and audible alarm at the trunk test rack.

In order that a circuit may automatically be returned to service following the clearance of a short-term failure, particularly where the circuits are controlled at an unattended exchange, the facility of "repeat clearing" has been included in the system design: the seizure and forward-clear signals are transmitted from the outgoing relay-set as a continuously repeated test sequence, controlled by a standard thermal relay giving a 50-second cycle time. When the release-guard signal is eventually returned correctly the circuit is released in the normal way.

### Pulse Correction of Repeated Signals

To obtain the advantages of pulse-corrected digit pulse-signals without using a pulse-storage method the new system employs a relay-type pulse-corrector element. This pulse-corrector element provides a delayed fixed-break output, using a capacitor-control circuit, and was developed in two forms: (a) using a standard double-contact high-speed relay, and (b) using two standard single-contact polarized relays. Details of the design and the performance of these two types of pulse-corrector, including the performance limits of type (b) when pulsing into a terminal-area network, have already been described in the Journal.<sup>2</sup>

Both of the types are used in the S.S.A.C. No. 9 system. The cheaper element, using the high-speed relay, controls the duration of the digit pulse-signals sent by the outgoing relay-set. These signals, representing the fixed-break output from the outgoing corrector, are transmitted within the limits shown in the table. The output of the incoming polarized-relay-type corrector is designed to transmit the digit pulse-trains from the incoming relay-set to the forward equipment with fixed-break limits of  $57 \pm 4$  ms.

The outgoing-circuit elements concerned with transmitting the seizure and digit pulse signals are shown in simplified form in Fig. 3. In the S.S.A.C. No. 9 system provision has been made for a "silent prefix" of at least 15 ms prior to the sending of any system signal to allow the receiver guard-circuit time to recover fully from the effects of any preceding d.c. surge. As indicated by the circuit-operation sequence shown in Fig. 3 the delay time of the outgoing-pulse corrector has been adapted to provide the silent prefix preceding a digit pulse-train.

The circuit elements concerned with seizure-signal recognition and digit-pulse repetition are shown in simplified form in Fig. 4. The performance of relays B and CD in this circuit is such that they will hold satisfactorily over the range of make and break durations of the received digit pulse-trains originated by a dial giving pulses within a range of 8-12 p.p.s.

### Safeguarding an Answered Call Against a False Forward Clear

The forward-clear recognition time is related to the performance limits of relays which must hold during pulsing, when they are not continuously energized, and is adequate to meet the voice-immunity requirement under normal circumstances. When, however, the room noise includes high-level "whistling" effects, either oral or similar to those that emanate from high-speed rotating machinery, such effects may succeed in imitating the 2,280 c/s signalling frequency for periods which exceed the forward-clear recognition time.

Although such occurrences are likely to arise very infrequently, the circuit has been designed, at very little additional cost, to prevent the loss of an answered call in these circumstances. This safeguard has been included by using relay XS in the outgoing relay-set (Fig. 3), and using relays already incorporated in the design of the incoming relay-set to provide a recognition

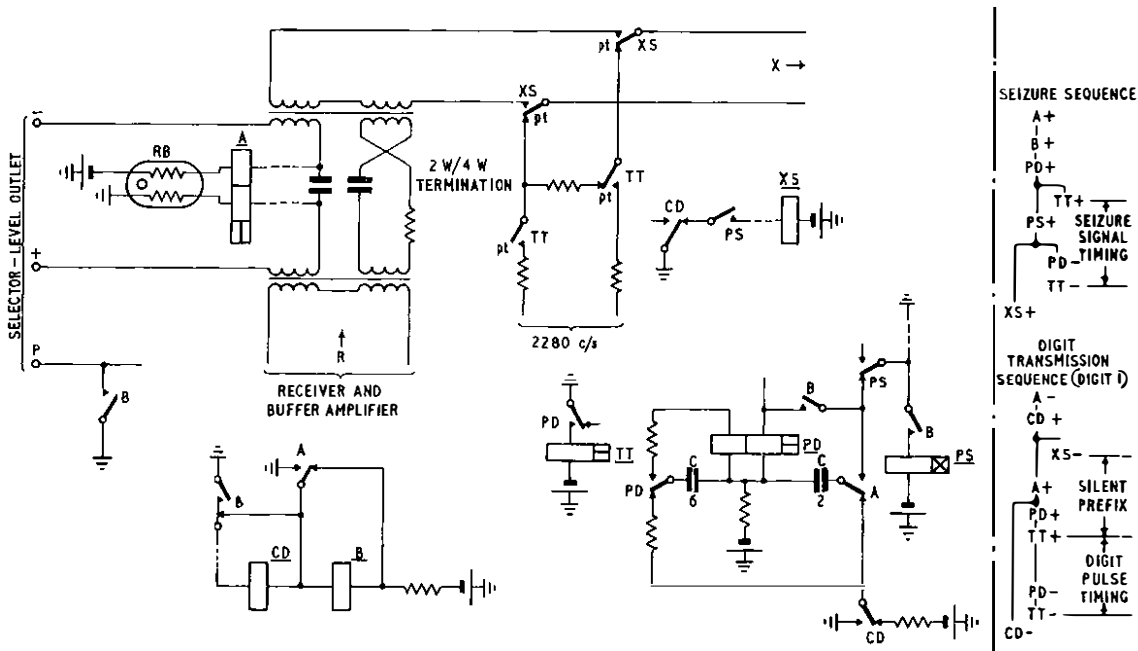

In the circuit-operation sequences shown at the right-hand side the letter codes refer to the relays; the + sign denotes operation of the relay and the - sign denotes its release.

FIG. 3—SEIZURE AND OUTGOING-PULSE-CORRECTOR CIRCUIT ELEMENTS

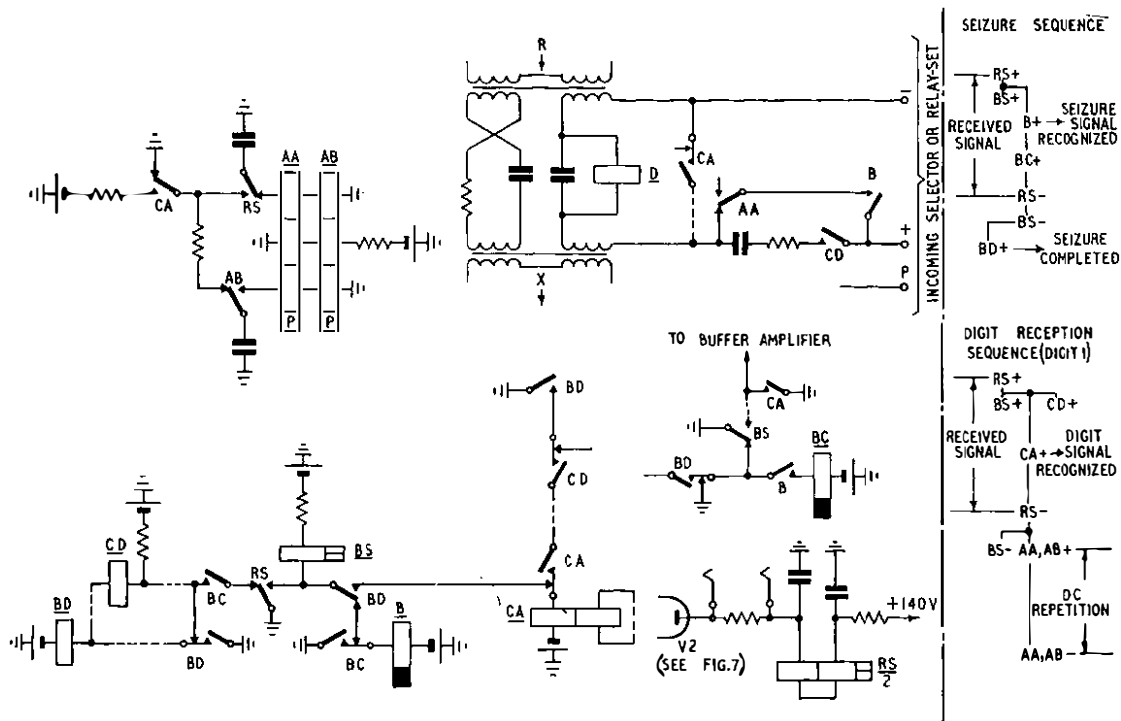

In the circuit-operation sequences shown at the right-hand side the letter codes refer to the relays; the + sign denotes operation of the relay and the - sign denotes its release.

FIG. 4—SEIZURE-RECOGNITION AND INCOMING-PULSE-CORRECTOR CIRCUIT ELEMENTS

time of 50–80 ms. If a continuous tone at the signalling frequency is received at an incoming relay-set which is in the answered-call condition, it returns a continuous signal after a delay of 50–80 ms. When this signal is received at the outgoing relay-set, the outgoing relay-set checks whether it is sending the forward-clear signal; if it is not, the continuous tone in the forward direction is interrupted by the release of relay XS, which splits the transmission path. The incoming relay-set then stops sending the continuous signal in the backward direction, and, when this signal ceases, the outgoing relay-set restores the transmission path. If the false signal is still present, the interaction between the incoming and outgoing relay-sets continues until the false signal ceases.

#### Line Splitting

To avoid misoperation of subsequent v.f. signalling systems in a connexion, v.f. signals should, as far as possible, be confined to the link on which they are used, and to achieve this a line-splitting technique is employed. Spill-over of signals from one link to another will occur during the operating time of the line-splitting arrangements, which time should, on the one hand, be short to minimize the spill-over but, on the other hand, sufficiently long to minimize false line splitting during speech due to signal imitation by the speech. The maximum period of spill-over should not exceed the minimum signal-recognition time of other systems using the same or nearly the same signalling frequency.

In the S.S.A.C. No. 9 system the line splitting occurs within the limits 5–15 ms before the called-subscriber-answer signal is received, but after this signal has been received the line-splitting time limits are 20–35 ms; by splitting the line within 35 ms the new system meets the C.C.I.T.T. recommendations. The line-splitting function is performed by the buffer amplifier.

#### Suppression of Near-End Interference

In the absence of special precautions, the near-end interference, in the form of speech or tones, will be received by a v.f. receiver connected to the receive path. This interference can be at a level within the normal working range of the receiver and could energize both the receiver guard circuit and the receiver signal circuit, or either one or the other, just prior to, or during the receipt of, v.f. signals. In the S.S.A.C. No. 9 system the suppression of near-end interference is performed by the buffer amplifier, a device which gives a high insertion loss in the direction 4-wire/2-wire termination to receiver and a substantially zero loss in the reverse direction.

#### Influence of Voice Immunity on the Choice of Signalling Code

The voice-immunity characteristics of the system as a whole have been assisted by the choice of the signal code. For instance, the lower limit of the signal recognition time for the clear-back signal has been set solely to provide immunity from speech imitation of this signal after the call has been answered as a normal metered call. Again, S.S.A.C. No. 9 permits 2-way speech transmission without the need to first receive an answer signal (a facility not given with S.S.A.C. No. 1) and the lower limit of the answer-signal recognition time has been set solely to provide voice immunity.

The upper limit for the transmitted durations of the answer and clear-back signals gives the new signalling system a reasonably fast speed of supervisory signalling. Furthermore, where the routing of a call is extended via a distant manual board, the single-pulse clear-back signal assists the operating procedure: the line splitting is not continuous during the time that a backward clear is indicated by the distant equipment.

As the answer and clear-back signals are transmitted



for similar durations and the recognition times are the same it has been possible to use a common timing relay for both these signals. For the foregoing advantages the system relies on the non-operation of the v.f. receiver for periods which would release this common timing relay when it is giving its minimum release lag of 100 ms. The lower limit for the forward-clear recognition time influences the characteristics of relay B which must remain operated during the signalling of digit pulse-trains. It will be seen that the limit required for this purpose is well in excess of that provided for voice immunity with respect to the answer and clear-back signals.

On routes controlled by operators, the distant receiver is exposed to any effects of speech that may be injected via the controlling operator's instrument during the inter-digital pauses. Thus, the voice-immunity performance of the v.f. receiver should be such that false operations of 20 ms occur very infrequently.

#### V.F. RECEIVER AND BUFFER AMPLIFIER

The v.f. receiver of a v.f. inband signalling system has to perform two main functions, the requirements of which are mutually opposed. It should convert the signalling pulse, which is of a frequency within the speech band, to a d.c. pulse without distortion, and it should not operate to speech currents. The practical design is always a compromise between these two conflicting requirements; the limits of pulse distortion and voice operation that can be tolerated are determined by the associated signalling and switching equipment.

The buffer amplifier, as previously mentioned, is used to guard the v.f. receiver from near-end interference. In the S.S.A.C. No. 9 system the buffer amplifier is also used to split the transmission path. Line splitting by the buffer amplifier is performed quickly but without causing noise in its output; this has been achieved by a novel and simple method.<sup>3</sup>

#### Factors Governing Design

The five main factors which governed the design of the receiver and buffer amplifier are indicated below but are not listed in any order of importance.

(i) Size. The receiver and buffer amplifier together occupy only eight relay spaces. This has been achieved mainly by the use of transformers requiring only one relay space each; the transformer assemblies are also used to mount associated components.

(ii) Cost. The cost is substantially lower than earlier v.f. receivers, due mainly to the use of a high-speed relay instead of a polarized relay.

(iii) Performance. The receiver and buffer amplifier meet the C.C.I.T.T. recommendations and the performance specification set for S.S.A.C. No. 9.

(iv) Ease of production. Attention was given, both in design and the component specification, to the necessity of being able to manufacture large quantities with their performance maintained within the allowed limits.

(v) Ease of maintenance. Only one type of valve is used in both the receiver and buffer amplifier. Should a fault develop in a transformer or an associated component the whole transformer unit will be changed, and facilities are provided so that the receiver signal-frequency resonant circuit can be re-tuned.

#### V.F. Receiver Design

**Voice Immunity.** The main design feature ensuring a good voice-immunity performance is the use of a

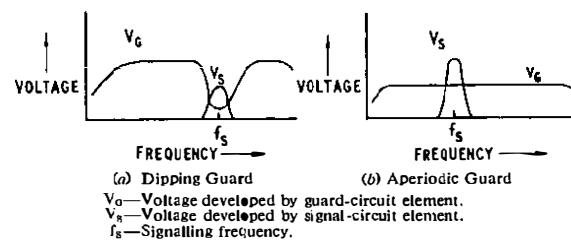

FIG. 5—GUARD-CIRCUIT CHARACTERISTICS

“dipping” guard characteristic which gives a considerable improvement over receivers using an aperiodic guard characteristic,<sup>4</sup> shown in Fig. 5 (a) and (b), respectively. The new design departs from the ideal dipping guard characteristic because, for considerations of cost and space, only two valves are used, one in an amplifier-limiter stage and one in the relay stage. With this arrangement it was necessary to use a tuned-anode load in the amplifier-limiter stage in order to obtain adequate amplification of the guarding frequencies relative to the signalling frequency. The resulting guard characteristic is shown in Fig. 6; the guard characteristic shown in Fig. 5 (a) has been reproduced in Fig. 6 to show the relative response of the two characteristics.

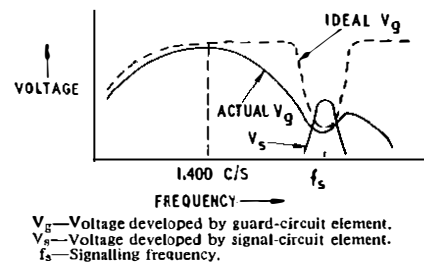

FIG. 6—S.S.A.C. No. 9 GUARD-CIRCUIT CHARACTERISTIC

Voice immunity<sup>5</sup> is considerably improved by the use of the higher signalling frequency of 2,280 c/s compared with systems having signalling frequencies such as the 600 and 750 c/s used with S.S.A.C. No. 1.

Voice immunity is also related to the operating bandwidth of the receiver: the narrower the bandwidth the better the immunity performance. The limiting factor is the bandwidth necessary to meet the pulsing limits, and the bandwidth chosen for any particular design of receiver is always a compromise between these two conflicting requirements.

The relative rise and decay time-constants of the signal and guard circuits have a bearing on the number of short operations recorded by a receiver. The design is such that the rise time of the guard circuit is less than that of the signal circuit but the decay time is greater, thus ensuring that the receiver does not operate at the beginning and end of each speech current which contains signalling as well as guarding frequencies.

**Pulsing.** The length of a pulse applied to the control grid of the valve in the relay stage is shorter than the v.f. signal applied at the receiver input. This reduction in pulse length is due mainly to the action of the signal and guard circuit voltage-doubler circuits which, for purposes of good voice immunity as explained previously, have differing charge and discharge time constants. For distortionless pulsing the operated time of the relay must be increased in order to give an output pulse equal to the input pulse.

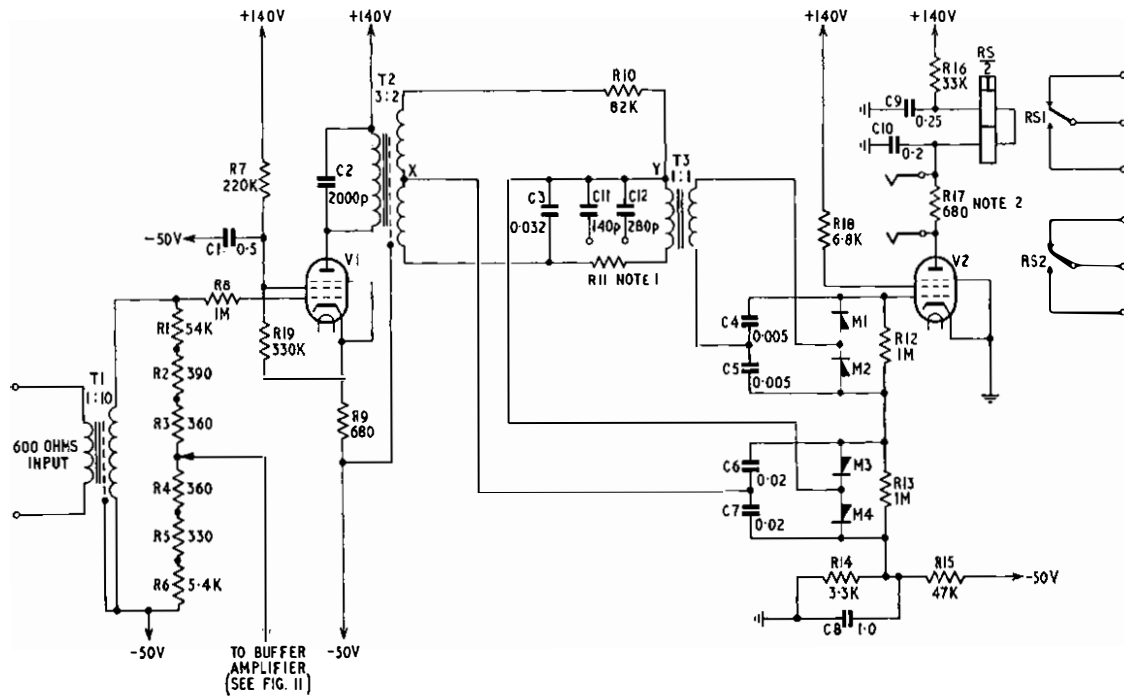

Notes: 1. Value of resistor R11 is chosen by manufacturer. 2. Resistor R17 is required for routine test purposes.  
 FIG. 7—S.S.A.C. No. 9 V.F. RECEIVER

The specified pulsing performance must be maintained under simultaneous adverse conditions of supply voltages, relay adjustment, input-signal level, and signal-frequency deviation. This requirement constitutes a difficult design problem which is partially solved by employing signal limiting over practically the whole of the input-level range. Thus, all rectifiers, capacitors, and the relay stage operate under almost constant conditions for varying input levels. A design having the relay operated in the "no-tone" condition offers minor advantages but was not used as receiver failure would cause seizure of the incoming selector.

#### Circuit Details and Operation of V.F. Receiver

The complete circuit of the v.f. receiver is shown in Fig. 7 and the various circuit elements into which it can be split are described below.

**Amplifier-Limiter.** Signals from line are fed via input transformer T1 to the control grid of pentode valve V1 (CV 138). The potential of the screen grid is made independent of the valve characteristics in order to stabilize the stage gain. Valve V1 operates with a short grid base, and input signals exceeding this grid base are amplitude limited on the negative half-cycles. Limiting also occurs on the positive half-cycles due to the 1-megohm resistor, R8, in the grid circuit.

These two features ensure that the peak-to-peak anode swing of valve V1 is substantially independent of the signalling level over the working range of + 3 dbm to - 15 dbm. Resistor R9 provides the bias to the limiting stage and its value was chosen to give symmetrical limiting of the input waveform; as R9 is not decoupled it helps to stabilize the operating point of the valve. The anode circuit of valve V1 consists of a transformer, the primary of which is tuned approximately to 1,400 c/s; the anode load is tuned in order to obtain sufficient pre-emphasis of the guarding frequencies relative to the signalling frequency (see Fig. 6).

**Frequency-Selective Bridge.** The voltage developed in the anode circuit of valve V1 is fed via the anode transformer T2 to the frequency-selective bridge circuit, consisting of the centre-tapped secondary winding of transformer T2, the signal-tuned transformer T3, and a balance resistor R10. The secondary windings of transformer T2 form two arms of the bridge, the balance resistor R10 and the parallel-tuned circuit (transformer T3 and capacitor C3) forming the other two.

When only the signalling frequency is received the tuned circuit is at resonance and has a parallel effective resistance of approximately 32,000 ohms. The bridge is then nearest to its balance point and the potential difference across points X and Y is a minimum, and the signal voltage developed across transformer T3 is a maximum. Complete balance of the tuned circuit at resonance by means of resistor R10 is not attempted as it is necessary to develop some guard output when a signal is being received so that the operating bandwidth of the receiver may be controlled, as indicated in Fig. 8.

At frequencies other than the signal frequency the tuned circuit is of low impedance and the bridge is unbalanced. Therefore, virtually no signal voltage is developed across transformer T3 and a higher potential is now developed across points X and Y; the maximum

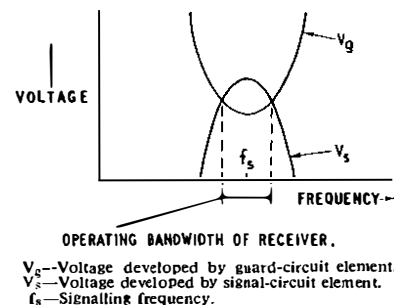

$V_g$ —Voltage developed by guard-circuit element.  
 $V_s$ —Voltage developed by signal-circuit element.  
 $f_s$ —Signalling frequency.  
 FIG. 8—CONTROL OF RECEIVER OPERATING BANDWIDTH

potential is developed across points X and Y at approximately 1,400 c/s, the frequency to which the anode load of valve V1 is broadly tuned.

The value of resistor R11 is chosen during manufacture so that the parallel effective resistance of the resonant circuit, with its associated voltage-doubler circuit and load connected, is equal to  $32,000 \pm 1,000$  ohms when measured at 6 volts r.m.s. This adjustment ensures a controlled signal-to-guard ratio from the frequency-selective bridge, which in turn ensures good pulsing and voice immunity. A typical value for resistor R11 is 80 ohms. Capacitors C11 and C12 are small capacitors used to finely tune the signal-frequency resonant circuit when the receiver is completely assembled or whenever a transformer unit is changed for maintenance reasons.

**Voltage-Doubler Circuits.** The guard and signal voltages from the bridge circuit feed two separate voltage-doubler networks. The load resistors, R12 and R13, of these networks are connected in series and to the grid of the relay-operating valve V2. As shown in Fig. 9, the polarity of the voltage outputs is such that the grid is driven positive (curve (d)) when the rectified signal voltage (curve (c)) exceeds the sum of the rectified guard voltage (curve (b)) plus the standing bias voltage.

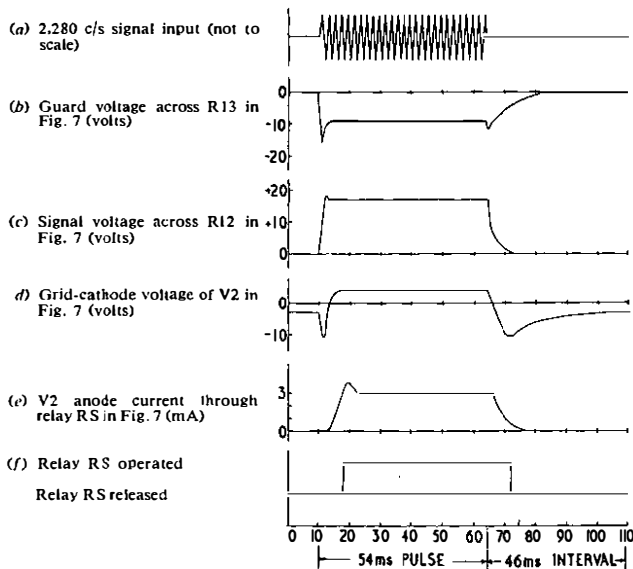

FIG. 9—WAVEFORMS IN THE V.F. RECEIVER ON RECEIPT OF A PULSE SIGNAL

As mentioned previously, the rise time of the guard circuit is designed to be less than that of the signal circuit but the delay time is designed to be greater to improve voice immunity. This is demonstrated by curves (b) and (c). The choice of the time constants, particularly the discharge time of the guard circuit, is also influenced by the need for a fast guard-circuit recovery after energization by noise currents.

**Relay Stage.** The reduction in duration of a pulse at the grid of valve V2 compared with the input v.f. signal can be seen by comparing curves (a) and (d) of Fig. 9. This reduction will be constant only if the voltage applied to the voltage-doubler networks is constant, and this is achieved as a result of the action of the amplifier-limiter. The pulse distortion is therefore practically constant with changes of level and frequency of a signal at the receiver input, within the specified limits, and may

thus be corrected in the relay-operating stage by lengthening the operated period of the relay by a constant amount; this is illustrated by curves (e) and (f) of Fig. 9.

The pulse-correcting circuit is illustrated by the curves shown in Fig. 10. The waveform of current through a

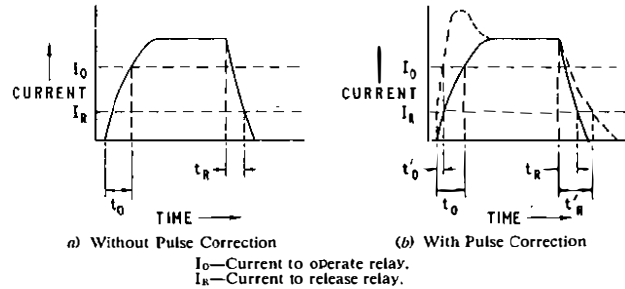

FIG. 10—PULSE CORRECTION IN V.F. RECEIVER

relay coil without a correcting circuit is shown in Fig. 10 (a). The time intervals  $t_0$  and  $t_R$  represent the relay operating and releasing lags, respectively. When no v.f. signal is being received no anode current flows in valve V2, and capacitors C9 and C10 (Fig. 7) are charged to the supply voltage. When a signal is received the anode current of valve V2 increases from zero, the potential of the anode falls and capacitor C9 partially discharges via the relay coil and valve. The resulting current waveform is shown in Fig. 10 (b) and it is seen that the relay operating lag is reduced from  $t_0$  to  $t'_0$ . Capacitor C10 also partially discharges but the resulting current passes via the valve only and not the relay coil.

When the v.f. signal ceases the anode current falls, the potential of the anode of valve V2 rises and capacitor C10 charges to the supply voltage. The resulting charging current flows via the relay and increases the release time. The current waveform through the relay is shown in Fig. 10 (b) and it is seen that the relay releasing lag is increased from  $t_R$  to  $t'_R$ . Capacitor C9 also charges to the supply voltage but the resulting current flows via resistor R16 only and not the relay coil.

Resistor R16 limits the V2 anode current when a v.f. signal is received and the valve bottoms with an anode current of approximately 3.0 mA; this limiting action is an additional factor in producing a square waveform through the relay. Resistor R16 also reduces the  $L/R$  ratio of the anode load and thus ensures a fast rise time of the V2 anode current. The potential divider, R14 and R15, provides a standing bias to valve V2 of approximately -3 volts. Resistor R18 limits the screen-grid current of valve V2 when anode current flows.

#### Circuit Details and Operation of Buffer Amplifier

As mentioned previously, v.f. signalling requires the receiver to be protected against near-end interference. The buffer-amplifier arrangement adopted for the S.S.A.C. No. 9 system gives an attenuation of the order of 60 db to near-end interference but, as the buffer-amplifier is connected in the speech transmission path, gives substantially zero loss to the speech. The buffer amplifier is also used to provide the line splitting which is necessary to limit the period of spillover of v.f. signals. The circuit of the buffer amplifier is shown in Fig. 11.

**Circuit Details.** The buffer amplifier uses a single pentode valve (CV 138) the gain of which is stabilized by series-connected voltage and current negative feedback. The voltage negative feedback is derived from a tertiary

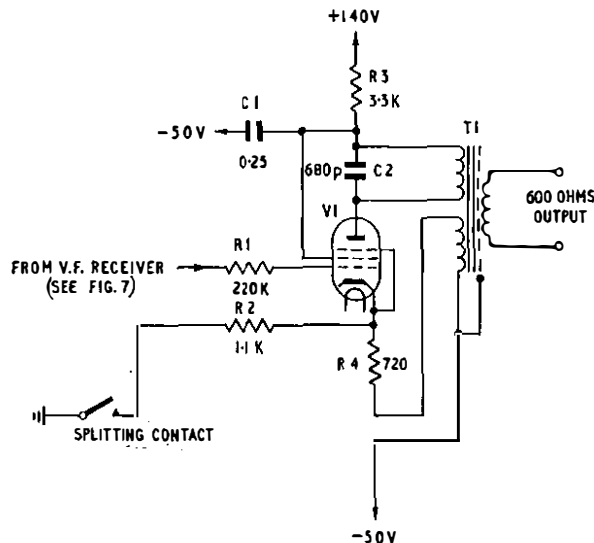

FIG. 11—S.S.A.C. No. 9 BUFFER AMPLIFIER

winding on the output transformer, whilst current feedback is derived from the bias resistor, R4, together with the resistance of the tertiary winding. The overall feedback of the buffer amplifier is such that the voltage gain between the primary winding of the input transformer (T1 of Fig. 7) and the secondary winding of the output transformer is unity. The overall amplification, therefore, is 0 db as both the input and output impedances are nominally 600 ohms.

The input transformer terminates the receiver transmission path and is common to both the buffer amplifier and the v.f. receiver. The resistor chain R1–R6 of Fig. 7, of a total value of 60,840 ohms  $\pm$  1 per cent, terminates the input transformer and provides for gain adjustment; resistors R2–R5 (Fig. 7) give an adjustment of nominally  $\frac{1}{2}$  db steps over a range of  $\pm$  1 db. The impedance as seen from the line via the 1 : 10 voltage step-up transformer is therefore approximately 600 ohms, which together with the resistance of the primary winding gives a total of approximately 630 ohms. This value is modified by the shunt loss of the transformer core and also when grid current flows in valve V1 of the receiver (Fig. 7) and in the buffer-amplifier valve, giving a nominal value of 600 ohms.

The responses of the input transformer at the extremes of the pass band, i.e. 300 and 3,400 c/s, are related to the open-circuit and short-circuit performances, respectively, of the transformer. The transformer design is such that the loss throughout the amplifier pass band will not exceed the mid-band loss by more than 0.2 db.

Resistor R1 (Fig. 11) reduces the shunting effect on the input impedance of the grid-cathode impedance at high-level signals. Capacitor C2 together with the output-transformer leakage inductance and leakage capacitance forms a simple low-pass filter which limits the frequency response above the required pass band, particularly in the region of the self-resonant frequency of the output transformer. The capacitor does affect the output return loss at the higher frequencies but has little effect over the pass band. Resistor R3 and capacitor C1 provide decoupling for the anode h.t. supply.

*Operation of Line-Splitting Circuit.* When the line-splitting contact in the associated relay-set is operated a

circuit is completed via resistors R2 and R4 and the tertiary winding of the output-transformer to  $-50$  volts. The cathode of the buffer-amplifier valve is then at a potential of approximately 27 volts negative with respect to earth, giving a cut-off bias relative to the grid, which is connected to  $-50$  volts, of approximately 23 volts; the valve is switched off.

Due to the very rapid fall in anode current the energy stored in the anode winding of the output transformer produces a surge which could cause noise in the output winding. However, this surge is neutralized by arranging for an equal and opposite surge to be produced in the output transformer by making the ampere-turns of the tertiary feedback winding equal to those of the anode winding. During the period in which the splitting action occurs the net change in flux in the output-transformer core is small and the resulting transient at the amplifier output is negligible.

#### Power Consumption for Receiver and Buffer Amplifier

The receiver input stage and the buffer amplifier are operated between  $+140$  volts and the exchange  $-50$  volts, giving a total h.t. of 190 volts. It is only possible, however, to operate the receiver relay stage between  $+140$  volts and earth potential as it is necessary to derive a standing cut-off bias for the valve from the  $-50$ -volt exchange battery. The 6.3 volt a.c. heater supply is obtained from the mains power panel. The approximate power consumption for the receiver and buffer amplifier is 6.5–8.5 watts.

#### CONCLUSIONS

The 4-wire connected 1 v.f. signalling system described above is of compact design and shows considerable economies over the earlier 2 v.f. system. Some routes equipped with S.S.A.C. No. 9 equipment are already in service and are operating successfully. However, since the initial development was completed, the v.f. receiver and buffer amplifier have been redesigned using transistors instead of valves so that they will operate from a nominal 50 volt supply obtained from exchange batteries. This later version of the S.S.A.C. No. 9 equipment with transistor-type receivers and buffer-amplifiers will be available for new installations in the near future.

#### ACKNOWLEDGEMENTS

As with all major developments, the development of S.S.A.C. No. 9 was the work of many colleagues, and the authors gratefully acknowledge their assistance during the preparation of this article. They also wish to acknowledge the assistance given during the development by Associated Electrical Industries, Ltd., who were associated with the Post Office under the British Telephone Technical Development Committee procedure.

#### References

- SMITH, D. C. Signalling System A.C. No. 1 (2 V.F.). *P.O.E.E.J.*, Vol. 44, pp. 66 and 144, July and Oct. 1951.
- GIBSON, R. W., and MAURER, C. J. A Pulse Corrector for Telephone Exchange Equipment. *P.O.E.E.J.*, Vol. 50, p. 239, Jan. 1958.
- ALLCOCK, P. R. Improvements in or Relating to Communication Circuits Including a Buffer Amplifier. British Patent No. 5077 (1958).
- WELCH, S. The Influence of Signal Imitation on the Design of Voice Frequency Signalling Systems. *I.P.O.E.E. Printed Paper*, No. 206, 1953.
- FLOWERS, T. H., and WEIR, D. A. The Influence of Signal Imitation on the Reception of Voice Frequency Signals. *Proceedings I.E.E.*, Paper No. 819, May 1949 (Vol. 96, Part III, p. 223).

## Notes and Comments

### New Year Honours

The Board of Editors offers congratulations to the following engineers honoured by Her Majesty the Queen in the New Year Honours List:

Brighton Telephone Area	..	B. C. A. Stone	..	Technical Officer	..	British Empire Medal
Engineering Department	..	D. A. Barron	..	Deputy Engineer-in-Chief	..	Commander of the Most Excellent Order of the British Empire
Engineering Department	..	J. H. Broadhurst	..	Senior Executive Engineer	..	Member of the Most Excellent Order of the British Empire
Engineering Department	..	R. A. Brockbank	..	Staff Engineer	..	Officer of the Most Excellent Order of the British Empire
Engineering Department	..	E. P. McManus	..	Cable Foreman	..	British Empire Medal
Factories Department	..	G. Simons	..	Telephone Mechanic	..	British Empire Medal
Long Distance Area, London	..	F. W. M. Richards	..	Technical Officer	..	British Empire Medal
Telecommunications Region						
Midland Region	..	L. L. Tolley	..	Chief Regional Engineer	..	Officer of the Most Excellent Order of the British Empire

### Recent Award

Cambridge Telephone Area	..	F. Greensides	..	Technician IIB	..	British Empire Medal, for Service in the Royal Air Force
--------------------------	----	---------------	----	----------------	----	--

### Retirement of Mr. C. E. Richards, F.R.I.C.

The retirement of Mr. C. E. Richards makes it uncomfortably clear to his nearer colleagues that Research Branch is approaching the end of an era. Starting in the early twenties, a small band of exceptionally able men built the Branch, and Richards can rightly count himself amongst the founders. In the early days he had to cope with a wide range of chemical problems, but gradually settled down to become an acknowledged authority on electrochemical corrosion, with special interests in lead cable-sheath damage. His interests, however, remained wide and he made himself a competent electrical engineer and metallurgist, doing useful work on metal fatigue.



During the war he organized the production and control of iron and alloy powders for dust-cores, and this led naturally to an interest in magnetic alloys in general. He

was later responsible for leading a team which studied the manufacture and testing of nickel-iron and silicon-iron, setting new standards of performance for the commercial producers. His pre-war interest in lead cables resulted in his spending some time during the war advising the Americans on the manufacture of the Pluto pipe-line. He was a Fellow of the Royal Institute of Chemistry.

It is probably true to say that Dick has almost as many friends as colleagues. A life-long attempt to hide a kindly and generous disposition under a rather sharp manner deceived no one and, towards the end of his career, he became the object of a widespread affection of which he seemed quite unaware. All at Dollis Hill join in wishing both Dick and Betty a happy retirement in the delightful village of Porthscatho. G.H.M.

### G. H. Metson, M.C., D.Sc., Ph.D., M.Sc., B.Sc.(Eng.), M.I.E.E.

Dr. Metson, who has recently been promoted Deputy Director of Research following Mr. C. E. Richards's retirement at the end of last year, has long been associated with the Post Office Research Station at Dollis Hill. He first joined it on entering the Post Office in 1925 as a Youth-in-Training and a few years later obtained his B.Sc.(Eng.) degree. During this period he was engaged in the Physics Laboratory with spectrography as one of his interests under Dr. (later Sir Gordon) Radley. In 1933, following his success in the Probationary Assistant Engineers' Competition, he was posted to Northern Ireland where he had a wide and varied experience of work in the field and in the handling of men—a period which he looks back on with considerable pleasure. During this time he registered as an internal student at Queen's University, Belfast, and carried out research on thermionic emission, earning the degrees of M.Sc. and Ph.D. in 1937 and 1940, respectively.

With the coming of the war a new phase of Dr. Metson's career opened and was one which he carried through with distinction: he went to France with the B.E.F. as a Territorial in the Royal Corps of Signals and following the evacuation in 1940 he was awarded the

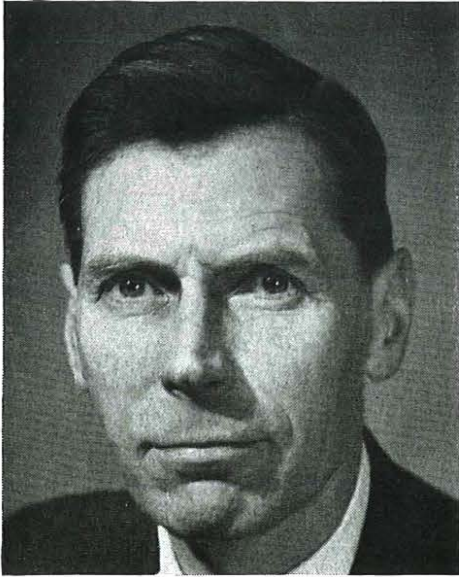

M.C. for gallantry. He rose rapidly to the rank of Lieutenant-Colonel and served in Africa, Italy and India, after which he returned to the United Kingdom and served in the War Office as General Staff Officer, Class I.

In 1946 he returned to Dollis Hill as Principal Scientific Officer in charge of the Thermionics Group and started studying the causes of failure of thermionic valves—work for which he was well prepared by his pre-war researches in Belfast.

He was promoted to Senior Principal Scientific Officer in 1951, and as the submerged-repeater cable work of the Post Office expanded the work of his team assumed greater and greater importance. In due course his Division extended their activities to the design and manufacture of very-long-life valves for use in submerged repeaters: work upon which the success or failure of such projects as CANTAT depended. Dr. Metson's own contributions to an understanding of the behaviour and causes of failure of oxide cathodes are extensive, as are his published papers which have earned him four premiums of the Institution of Electrical Engineers and a world-wide reputation.

In 1956 he was appointed Deputy Chief Scientific Officer under the "Special Promotion on Individual Merit" scheme for the Scientific Civil Service—a promotion of unusual distinction which gave his colleagues great pleasure; and in 1958 he was awarded the degree of D.Sc.

Throughout his career he has shown himself to be a clear-sighted and dedicated worker and an inspired leader—qualities which will stand him in good stead in the next phase of his career.

H.S.

#### **Retirement of Mr. H. R. Harbottle, O.B.E., B.Sc.(Eng.), D.F.H., M.I.E.E.**

Mr. H. R. Harbottle, O.B.E., who retired as Staff Engineer of Training Branch, Engineering Department, on 6 February, was born at Mexborough, Yorkshire, in October 1900. He was educated at King's School, Pontefract, from which he obtained an Open Faraday Scholarship to Faraday House, London, where he studied under the late Dr. Alexander Russell and obtained

the D.F.H. and B.Sc.(Eng.). He entered the Post Office in 1920 as a Temporary Inspector in the Research Section of the Engineering Department, at that time located in King Edward Building. He became an Assistant Engineer (old-style) in 1922 and was one of the pioneers in setting-up the Research Station at Dollis Hill, where he was engaged in research on microphones, protection devices, local-line transmission, electrical-interference noise measurement and other special electrical measurements. He was promoted to Executive Engineer (old style) in 1933.

In addition to his Post Office work, he undertook in 1922 the work of an evening lecturer at Borough Polytechnic and later at Regent Street Polytechnic, where he quickly established a reputation as a teacher of Technical Electricity and Line Transmission. This teaching work continued until the outbreak of the war in 1939. In August 1938 he had been promoted to Assistant Staff Engineer in the Lines Branch where he was concerned with Cable Provision, but later that year he was given a special assignment to plan and put into operation the Defence Teleprinter Network (D.T.N.) and the Defence Telecommunications Controls (D.T.C.), both in Great Britain and the Continent of Europe. This work culminated in his being in charge of the Engineer-in-Chief's War Group for the period 1939-45, in which he gave most distinguished service and for which he was awarded the O.B.E.

In July 1945 he became Deputy Chief Regional Engineer of the London Telecommunications Region, and in May 1946 he was selected to be the first Staff Engineer of the newly formed Training Branch. This involved him at once in the task of setting-up the residential Central Training School at Stone, Staffordshire, where his particular talent of good-humoured but firm leadership enabled him to overcome the many difficulties which beset this project. During the 15½ years that he has been head of Training Branch he has been associated with many progressive features of Post Office training and education, including training for supervision and management, day release for further education, the sandwich course and bursary schemes, and the student

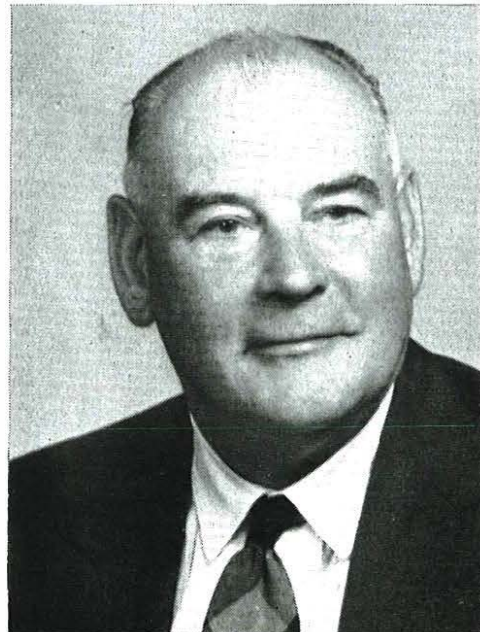

apprenticeship scheme. As a sequel to his activities as a part-time technical teacher he became a City and Guilds examiner in Technical Electricity in 1942 and afterwards an examiner in Telecommunication Principles, an activity which he still continues.

In 1956 he decided to move his home to Ringmer, Sussex, and as a result of six years' residence he has now developed and consolidated many local interests which will suffice to keep him busy during his retirement. He owns a sea-going motor cruiser and is Treasurer of the Newhaven Deep-Sea Anglers' Association. The nearness of Glyndebourne to his Sussex home also enables him to participate in his life-long interest of operatic singing. His many friends in the Post Office and the telephone industry will all miss his cheeriness and kindness, and wish him long life, health and happiness in his retirement.

F.C.M.

**R. O. Boocock, B.Sc., A.M.I.E.E.**

Mr. R. O. Boocock, who has been appointed Staff Engineer, Training Branch, joined the Post Office in 1926 as a Probationary Inspector and was engaged, in the North Midland District, mainly on local-line planning, cable balancing and precision testing. He became a Probationary Assistant Engineer (old style) in 1931 and from 1932 to 1934 was Assistant Engineer in the Cambridge Section, where he was responsible (with Mr. L. G. Semple) for the first experiments in laying cables by moledrainer, and for the first Cambridge-King's Lynn cable, which was mostly laid by this method. In 1934 he was transferred to the Eastern District Headquarters for oversight of the planning involved in the very rapid growth of main and local cables in East Anglia at that time. After short periods as Efficiency Engineer and Executive Engineer (old style) in charge of the Technical Section he served from 1940 to 1947 as Area Engineer, Cambridge, where he was particularly concerned with war-time emergency planning, and the provision and maintenance of service at the numerous aerodromes and other Services centres in this part of the country.

Since 1947 Mr. Boocock has been Regional Engineer in the Home Counties Region, dealing with the maintenance of all types of plant. He has been concerned primarily with the furtherance of efficiency in both fault rate and costs, especially by watching the detailed statistics, study of methods, and the steering of effort into the most profitable channels. He has given much time also to the development of schemes for the control of routines and the testing of poles.

The enviable position of Home Counties Region in the maintenance field is in no small measure due to the enthusiasm with which he has applied himself to the direction of the maintenance effort, and there is no doubt that he will bring his characteristic persistent determina-



tion to bear on the problems he will meet in Training Branch.

His friends and colleagues everywhere wish him well in his new appointment.

A.H.C.K.

**Mr. D. A. Barron, C.B.E., M.Sc., M.I.E.E., Chairman of the Board of Editors**

The members of the Board of Editors have noted with pleasure the C.B.E. which Her Majesty the Queen has recently conferred upon their Chairman, Mr. D. A. Barron.

**Circulation of The Post Office Electrical Engineers' Journal**

The Board of Editors is pleased to note the continuing increase in the circulation of the Journal, as shown by the following statistics.

Journal Issue	Number of Copies Printed
Vol. 53, Part 1, Apr. 1960	21,100
Vol. 53, Part 2, July 1960	21,200
Vol. 53, Part 3, Oct. 1960	21,500
Vol. 53, Part 4, Jan. 1961	21,900
Vol. 54, Part 1, Apr. 1961	23,300
Vol. 54, Part 2, July 1961	23,500
Vol. 54, Part 3, Oct. 1961	23,700
Vol. 54, Part 4, Jan. 1962	24,100

Approximately 10 per cent of the Journals are sold to overseas readers in more than 50 countries.

# Institution of Post Office Electrical Engineers

## Retired Members

The following members, who retired during 1961, have retained their membership of the Institution under Rule 11 (a):

- W. F. Bevis, 38 Village Way, Rayners Lane, Pinner, Middlesex.  
J. H. Watson, 26 Westwood Avenue, Timperley, Altrincham, Cheshire.  
A. N. McKie, 81 Suffolk Road, North Harrow, Middlesex.  
A. E. W. Maslin, 13 Greenwood Avenue, Cosham, Portsmouth, Hampshire.  
F. H. Horner, 502 Bexhill Road, St. Leonards-on-Sea, Sussex.  
J. Lawton, 6 Corona Avenue, Oldham, Lancashire.  
F. H. Proctor, "Bishops Garth," Sea Road, Fairlight Cove, Hastings, Sussex.

S. WELCH,  
General Secretary.

## Additions to the Library

Library requisition forms are available from Honorary Local Secretaries, from Associate Section Centre Secretaries and representatives, and from the Librarian, I.P.O.E.E., G.P.O., 2-12 Gresham Street, London, E.C.2.

- 2657 *Automobile Transmission Servicing and Overhaul*. S. Abbey (Brit. 1961).  
Includes conventional and automatic transmissions, two-pedal controls, clutches, gearboxes, propeller shafts and rear axles. Emphasis is on work within the scope of a practically minded owner or smaller garage.  
2658 *Modern Physics*. M. S. Smith (Brit. 1960).  
Requires a good knowledge of physics (including wave theory) and some knowledge of elementary chemistry, plus a willingness to think about the logical and philosophical bases of the subject.  
2659 *Principles of Semiconductors*. M. G. Scroggie (Brit. 1961).  
An introduction to the properties and applications of semiconducting materials.  
2660 *Mathematics in Your World*. K. Menninger (German 1958).  
An informal book on the nature of mathematics

and mathematical thought.

- 2661 *The Earth, the Planets and the Stars*. K. E. Edgeworth (Brit. 1961).  
Deals with the structure and past history of the Earth and the solar system, and with the past history and distribution of the stars.  
2662 *The Scientific American Book of Projects for the Amateur Scientist*. C. L. Stong (Amer. 1960).  
Experiments, constructions, challenges and diversion in various fields, selected from Mr. Stong's clearing house of amateur activities appearing monthly in *Scientific American*.  
2663 *Founders of British Science*. J. S. Crowther (Brit. 1960).  
Looks at the life, social background and work of six great founders of British Science: Wilkins, Boyle, Ray, Wren, Hooke and Newton.  
2664 *Radio & Television Servicing (1960-61 Models)*. J. P. Hawke and J. Reddihough (Editors) (Brit. 1960).  
Contains the servicing data for the 1960-61 models and covers tape recorders.  
2665 *Introduction to Transients*. D. K. McCleery (Brit. 1961).  
An attempt at a simpler approach to the study of transient phenomena using the Heaviside operational calculus.  
2666 *The Art of Administration*. A. L. Banks and J. A. Hislop (Brit. 1961).  
Intended for the professional man coming into contact with administrative machinery for the first time.  
2667 *Colour Television. N.T.S.C. System, Principles and Practice*. P. S. Carnt and G. B. Townsend (Brit. 1961).  
Provides a comprehensive account of the American N.T.S.C. colour-television system, and the British and Continental versions, from the point of view of the colour-receiver engineer.  
2668 *Hot Water Supply: Design and Practice*. J. J. Barton (Brit. 1961).  
A comprehensive treatise, explaining the details in a practical way without unnecessary theory.

W. D. FLORENCE,  
Librarian.

## Book Review

"Television Receiver Servicing—Vol. I. Time-Base Circuits." Second Edition. E. A. W. Spreadbury, M.Brit.I.R.E. Iliffe Books, Ltd. viii + 362 pp. 214 ill. 25s.

This is the second edition of a book first published in 1954 and reviewed in the July 1954 issue of this Journal. Since then the second-program television service has become firmly established on an almost nationwide basis and the number of television licences issued in the United Kingdom has more than doubled to reach the present staggering total of over eleven million. The shape, size, and performance of television receivers have undergone some very noticeable changes during this period and it might be expected that considerable changes in the circuit design would also have taken place. However, in so far as the time-base section of the receiver is concerned, a comparison of this book with its earlier counterpart does not show many very significant changes. It may be, of course, that more far-reaching developments will be found when the second volume, dealing with the receiver proper, is brought up to date.

The most notable development that has taken place is undoubtedly the introduction of the wide-angle (110°)

cathode-ray tube, which has enabled the back-to-front dimension of the domestic television receiver to be reduced in a spectacular manner. This has entailed a number of modifications in the design of time bases and these are fully dealt with. Other notable features are the trend towards electrostatic focusing and the more widespread use of flywheel synchronizing. A number of new circuits for achieving the latter are now described.

Apart from the sections dealing with these developments the book is almost identical with the earlier edition. As before, the first chapter is entitled "Symptom: Blank Screen" and goes on to analyse the faults that may give rise to this symptom. Once something is visible on the screen this will in itself assist in the tracing of any other faults in the receiver. The time bases, tube supply, and ancillary circuits are all described in detail with many practical circuit diagrams taken from normal domestic receivers. The book is intended primarily for the professional service engineer but it will also be found extremely valuable by the amateur. The latter, in particular, should take note of the section on safety that has now been added at the end of the book.

I.P.O.E.E. Library No. 2211.

T. K.



## Regional Notes

### Northern Ireland

#### A NEW BI TIMBER BUILDING

The erection of a new type of prefabricated timber U.A.X. building has been completed recently in Northern Ireland and is shown in the photograph. The building, designed and manufactured locally, was erected with the agreement of the Exchange Equipment and Accommodation Branch, Engineering Department, as an experiment to ascertain if a fully prefabricated building, superior in appearance and finish, could be erected more quickly and at a lower cost than the existing standard type. This proved to be so in this instance.

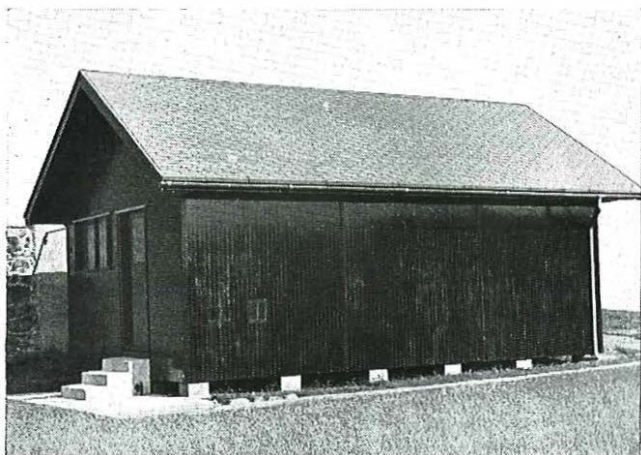

A NEW BI TIMBER BUILDING DESIGNED AND BUILT IN NORTHERN IRELAND

The new building has the same dimensions as the standard B1 type, but here the similarity ends. Instead of the usual concrete raft, which involves placing approximately 10 tons of hardcore and 15 tons of concrete, the floor is of timber and rests on concrete piers that can be either cast in situ or precast elsewhere and delivered to the site. The saving in concrete alone was considerable as only four tons were used. No hardcore was used in the building foundations.

The new building is clad externally with  $\frac{3}{4}$  in. thick marine plywood, glued to the wall framework with Aerodux glue, a quick-setting waterproof adhesive. Incidentally, the plywood used is a type developed solely for yacht decking; it is hardwood faced and very attractive in appearance. The roof of timber boarding, laid diagonally for strength, is in eight sections, and is so designed that when erected, roof trusses are formed which tie the complete roof structure together. The roof is finished in Ruberoid strip slates which are fixed after erection is completed.

Plastic self-coloured rainwater fittings are used on the building; these are light yet strong and require no further decoration.

Internally, the walls are lined with foil-backed plaster-board, although it was the intention to use a plastic-faced type for this purpose. Price, however, ruled out the latter material, but it is believed that the plastic-faced walls would be just as economical in the long run as these require no initial or subsequent decoration.

Yet another innovation is the elimination of the conventional cable trench. Polythene cables are to be used for the cable lead-in, these being terminated direct on the C units. For lead-in purposes, a single 6 in. diameter earthenware pipe extends from the joint box located just outside the building to a position below the C units. Removable covers of 1 in. marine plywood are provided at the floor level to facilitate drawing in and termination of the cables.

The building was decorated externally with a new type of cold-setting lacquer based on synthetic resins (polyurethane lacquer). This material forms a hard, yet flexible, insoluble film which not only enhances the timber to which it is applied, but gives a high degree of protection against adverse weather conditions. The first coat was put on by spray gun in the workshop, the two subsequent coats being applied on site by brush.

The building as erected is fully up to our expectations and we are confident that it will prove more durable and require less maintenance expenditure than the existing standard type.

E.G.L.

### Home Counties Region

#### NEW AUTOMATIC TELEPHONE EXCHANGE AT LOWESTOFT

At 1.30 p.m. on Thursday, 21 September 1961, the new non-director automatic telephone exchange at Lowestoft was opened by the Mayor of Lowestoft in the presence of a small group of prominent local people. The new exchange replaced the manual exchanges at Lowestoft, Oulton Broad and Pakefield. Although exchange transfers are quite commonplace there are two items which are worthy of mention in connexion with this conversion. Firstly, the CB 12 manual exchange at Lowestoft, which had been in operation since 1915, was one of the few remaining exchanges with a series breakjack multiple and, secondly, this was the first occasion in the Region when a manual to automatic exchange conversion had been accompanied by the introduction of subscriber trunk dialling (S.T.D.) and pay-on-answer coin-boxes.

The new exchange, which was installed by Standard Telephones and Cables, Ltd., has an initial multiple capacity of 4,200 lines, and is housed in a new modern building which also accommodates the auto-manual switchboard and the S.T.D. equipment. The automatic exchange is equipped with Post Office 4,000-type selectors, and 50-point uniselectors are used as line-finders to serve residential lines. Sixteen joint trunk positions, four inquiry positions and a supervisor's desk are installed in the switchroom, and a service-observation desk is provided in an adjacent room. Nine electromagnetic registers and two translators are provided for S.T.D. traffic.

To reduce the traffic on the heavily overloaded Lowestoft manual exchange before the peak of the 1961 holiday season, the surrounding U.A.X.s were parented on the new exchange early in July 1961. This increased the number of tie circuits necessary to the old exchange, but it simplified the arrangements for the main transfer and enabled the pay-on-answer coin-boxes to be installed in readiness for the opening of the new exchange. The 95 coin-boxes concerned were changed in the two weeks immediately prior to the transfer. Trials of the trunk and junction network jointly by engineering and traffic staff enabled a reduction in overall testing time to be effected and the close co-operation between the two staffs throughout the many facets of this conversion was an essential contribution to its success. An exhibition comprising automatic exchange, S.T.D. and pay-on-answer coin-box demonstration equipment was set up in a local showroom and was well attended by the public.

An extensive program of re-arrangements of external plant, including much-needed development work, was completed in time for the transfer.

E.W.F.S.

### North Eastern Region

#### DUST CONTROL IN TELEPHONE EXCHANGES

The cleaning of apparatus-room floors and racks has followed the same pattern for many years, and has been

carried out with conventional brushes, dusters, etc. These methods are not entirely satisfactory, because it is difficult to prevent dust disturbance which results in the dust being re-deposited on other surfaces.

A field trial of a proprietary dust-control system is being carried out at Newcastle Central Exchange; the basis of the system being a cloth impregnated with an oil which holds dust and dirt on contact. The level of impregnation is closely controlled by the supplier so that no streaky residue is left behind after the cloths have been used. The cloths are available in cover form to shroud sweeping tools and also in the form of dusters. Both materials and tools are hired on a fortnightly basis from the firm supplying the service. The trial, which is an extension of an Engineering Department field trial, has been in progress in this Region for some three months, and, although full evaluation cannot be made yet, the results so far are most promising.

T.W.

### London Telecommunications Region

#### A YEAR OF ACTIVITY IN LONG-DISTANCE AREA

The year 1961 was one of outstanding activity in the Long-Distance Area. The final and most important event occurred on 19 December 1961 when the new CANTAT communication link between London and Montreal was opened. This new link will be used to add to the communication circuits across the Atlantic and it also forms the first part of the Commonwealth telephone cable system.

During the first half of the year a large number of contract and direct labour works were in progress preparing for the program of events which were scheduled for the second half of the year. A brief note of each item is given in chronological order.

1 July. The first centralized register-translator unit affording subscriber trunk-dialling (S.T.D.) facilities for London subscribers was opened in the Citadel Building. At the end of the year there were 15 exchanges connected to the unit using over 2,000 junctions and 600 trunk circuits. Another 400 trunk circuits have also been provided for routing calls via other Long-Distance Area trunk automatic-exchange units.

26 July. A new 4-wire switching unit was brought into service for switching incoming continental circuits to inland trunk circuits on a 4-wire basis, thus giving improved transmission. This unit opened with 300 circuits incoming from the Continent and about 150 inland trunk circuits.

4 August. A new suite of test-control positions had been constructed by direct labour in the Faraday North Block, and, with the new repeater equipment which had been installed under contract, the new International Maintenance Control (Atlantic) and the new International Repeater Station were formed. The international circuits associated with the first transatlantic telephone (TAT-1) cable were transferred from the Kingsway trunk-switching unit to the new installation in the North Block of Faraday Building on 4 August. This transfer required the complete realignment of the 15 h.f. groups between London and Oban and comprehensive end-to-end tests on individual circuits.

August and September. Throughout the year work had been in progress rewiring the switchboards in the main switchrooms on the second floor. When this work was completed, a number of rearrangements of switchroom use were made during August and September.

The international circuits were then changed from the Wood Street building to the main second-floor switchroom at Faraday building on 13 November, and these changes together with the other rearrangements made it necessary to provide some 37,000 cross-connexions. Change-over facilities had to be provided so that there was the minimum interruption to service.

3 October. Over 100 4-wire circuits outgoing to the Continent were brought into service with as many inland trunk circuits. A considerable number of groups of continental circuits had to be rearranged in preparation for the

opening of the outgoing service from this unit, and on the Berne, Switzerland, route in particular the rearrangements had to be planned into 28 separate operations so as to maintain service while the work was being completed.

19 December. On this day the new CANTAT link was brought into service following an inaugural call by Her Majesty the Queen. For the opening ceremony special circuits had to be provided to Lancaster House, London, where the guests were assembled. Program-type circuits for relaying music, demonstration circuits, press circuits and picture circuits were all provided.

Immediately the inaugural ceremony was completed these special circuits had to be disconnected and the various channels of the CANTAT system were tested and brought into service. The circuits were 17 London-Montreal traffic circuits, 10 Montreal-Continental circuits and three telegraph main circuits.

When this was completed the overall line-up and testing was carried out on the two groups (24 circuits) extended from Montreal to New York to form an additional London-New York link. These circuits were 10 London-New York traffic circuits, 13 New York-Continental circuits and five telegraph main circuits.

B.H.M.

#### OPENING OF NORTHWOOD AUTOMATIC TELEPHONE EXCHANGE

At 1.30 p.m. on Wednesday, 8 November 1961, 4,198 subscribers were transferred from the old CB No. 1 exchange to a new non-director exchange at Northwood. The equipment was installed by Standard Telephones and Cables, Ltd., who installed the original manual exchange in 1932.

The new exchange uses 4,000-type equipment, with 50-point line-finders and uniselector calling equipment. The power unit is a Power Plant 210 J with a battery capacity of 800 amp-hours.

Solderless wrapped terminations\* are incorporated on all frames and racks as an alternative to soldered connexions. The tags for such connexions are solder-coated and notchless. A special tool is used to strip the ends of the wire for a pre-determined length and each end is then wrapped around the tag with a special tool. The wrapping tool or gun consists of a 110-volt power drill, the chuck of which grips a slim hollow barrel  $1\frac{1}{2}$  in. in length. A further hole off-set from the centre within the hollow barrel receives the bare wire. With the wire correctly placed in the hollow barrel, the gun is applied to the tag and switched on. This causes the wire to be evenly wrapped round the tag six times without relaxation of the tension.

To ensure that all wrapped terminations are uniform and conform to specification each wrapping tool or gun is tested daily before use; each test termination should resist a "pull-off" force of  $6\frac{1}{2}$  lb and the median value from a series of five tests must be less than 9 lb. Should this test fail the tool is withdrawn from service.

A.E.A.

#### ENGINEERING TRAINING

The increased recruitment of Youths-in-Training and adults which has taken place in the last year or two has necessitated an unprecedented expansion of engineering training facilities in the Regional Training School in the London Telecommunications Region. In addition, the introduction of new techniques and equipment such as the gas pressurization of cables, the new coin-collecting box for subscriber trunk dialling (S.T.D.), the cordless switchboard P.M.B.X. 2/2A, and S.T.D. metering facilities for P.M.B.X.s have also increased the need for training. Other urgent training arrangements, now in the planning stage, will provide for the new preliminary and general automatic systems courses, which are being devolved from the Central Engineering Training School, for the new wiremen's course for power

\* Hix, K. W. Solderless Wrapped Joints in Telephone Exchanges. *P.O.E.E.J.*, Vol. 54, p. 204, Oct. 1961.

staff and for a workshop course for Youths-in-Training engaged on power work.

The recent increase in the Regional training estimates is shown by the following figures, which also show the approximate numbers of students and the "student-weeks" for the years 1960-61, 1961-62 and 1962-63.

	1960-61	1961-62 (Estimated)	1962-63 (Estimated)
Students	3,960	7,050	7,150
Student weeks	12,025	23,200	23,500

Existing engineering training accommodation in five separate establishments in the Region is in full use and additional requirements are being met by the use of accommodation in new or existing buildings, which is not at present required for its planned purpose, the acquisition of a new building and the temporary use of space provided by Telephone Managers.

The greater part of the first floor and part of the second floor of Fleet Building in Farringdon Street have been equipped as an engineering training school for external, internal and Youths-in-Training courses and it is now in operation with five simultaneous courses. All lecture and practical-work rooms are acoustically-treated and air-conditioned. In addition, the use of other premises is being negotiated for training courses on automatic telephony and power duties for Youths-in-Training from all Regions. Telephone Managers have provided accommodation in different parts of the Region for six Regional Engineering Training School preliminary courses on fitting and jointing.

The maximum number of simultaneous courses in operation is now 28 of which about 12 are Youths-in-Training (A and B) courses. A number of courses on power and

telecommunications are conducted for all Regions in the country.

The following table shows the amount of training arranged for Regional students attending courses at the Central Training School, Stone. The increase is due to new S.T.D. courses, the replacement of the basic automatic telephony course by two courses, the need for increased numbers of external-planning staff and the introduction of new types of line connector.

Year	1958-59	1959-60	1960-61	1961-62	1962-63
Number of students attending courses	1,049	1,412	1,408	1,600 (Estimated)	1,600 (Estimated)

A further commitment is the amount of training now required for supervising officers, both departmental and non-departmental. The figures for the Region during 1961 are as follows:

Student apprentices	.. .. .	3
Sandwich course students	.. .. .	8
University vacation students	.. .. .	8
Limited competition Assistant Engineers		12
Contractors' student apprentices	.. .. .	7
Overseas students	.. .. .	4
		—
		Total 42

The increased recruitment of Youths-in-Training, advances in technique, the possible further devolution of courses from the Central Training School, Stone, the need for more management courses and the general expansion of the telephone and telegraph system will, it is expected, result in still greater demands for training from 1962 onwards.

E.M.G.-R.

## Associate Section Notes

### Guildford Centre

On 31 August 1961 ten members paid an evening visit to the *Daily Mirror* offices, where the production of the following day's newspaper was seen. A copy of this was given to each member on leaving the building.

Our program for this session has been:

- 10 September: Mr. C. A. May, Telephone Electronic Exchange Systems Development Branch, gave an illustrated talk entitled "Introduction to Electronic Telephone Exchanges." This was followed by a lively question time.
- 25 October: 20 members had an interesting half-day visit to Pirelli-General Cable Works, Ltd., at Southampton.
- 24 November: A very enjoyable show was organized by one of our members, Mr. M. Spice.
- 20 December: A whole day visit was paid by 30 members to Vauxhall Motors, at Luton.
- 22 January: A talk "S.T.D. as it affects the Non-Director Exchange" was given by Mr. B. B. Gould of the Telephone Exchange Systems and Developments Branch, Engineering Department.
- 20 February: A talk and short film on "Advanced Driving" was given by a member of the Surrey County Constabulary.
- 30 February: A film show was given in the Prince of Wales, Guildford.

The Centre would like to thank Mr. H. W. Harrison, the Regional Liaison Officer, who retired in February, for his help and advice, and also to wish him well in his retirement.

J.F.T.W.

### Bournemouth Centre

We are pleased to report that the Bournemouth Centre has been reopened successfully, and well attended visits have been made to the following places:

- 24 May: Pirelli-General Cable Works, Ltd.
- 5 July: Poole Power Station.
- 19 August: Hurn Airport.
- 21 October: Lecture and tour of the United Kingdom Atomic Energy Authority station at Winfrith.

The annual general meeting was held on 22 November and the officers and committee were elected. The meeting was followed by a most interesting lecture given by Mr. F. Guscott entitled "Subscriber Trunk Dialling."

The officers are at present arranging a most interesting program for the months ahead. At present we have 50 members and we hope for full support from all our colleagues to ensure our continued success in the future.

P.M.K.

### Bath Centre

Meetings have been held monthly during the Autumn session. The lectures have been well attended and received.

In October, Mr. E. S. Woods, M.B.E., gave a double-feature program dealing with both his work and hobby. Mr. Woods, who is a Senior Communications Engineer with the Lines Branch of the B.B.C., talked freely on the problems that beset a lines engineer, and some of the solutions that he has used during 33 years of outside-broadcast duties. Such is his distinction in this field, that

he was awarded the M.B.E. for his services to broadcasting in 1958. Mr. Woods was also persuaded to talk on his hobby, bee-keeping, and, in particular, the adaption of electronic techniques in studying the habits and behaviour of the creatures. Much of his research in this respect has been original, and has won him innumerable fellowships of Institutes and Universities throughout the world. Such was the mutual interest of speaker and audience, that his excellent lecture lasted until 10.30 p.m.

Mr. P. Morgan visited the centre in November and spoke of his job as Main Works Controller in the Bristol Area, under the title "Life Cycle of an External Estimate." The lecture was illustrated with film and slides of local projects and of the control procedure.

The Chairman of the Centre was invited to attend the December meeting of the Senior Section, at Bristol University, to witness the presentation of awards gained by two Bath members in the national competition for a written paper. Mr. C. E. Moffat (Chief Regional Engineer), congratulated Mr. C. W. Read upon the prize gained by his paper on "Transistors," and also his recent promotion to the regional planning office.

A prize and Institution Certificate were awarded to Mr. D. G. Rossiter for his paper entitled "The Atom and its Energy." The C.R.E. congratulated Bath on receiving their fourth certificate in 11 years; a record which he thought to be excellent, and one which few provincial centres could match.

A former centre member, Mr. R. M. Burt of the Bristol Area Traffic office, was the December lecturer. He presented a splendid account of the functions and responsibilities of the Traffic Department under the title "Traffic Work. What the Deuce is That?" His treatment of the subject was as lively as his provocative choice of title; members enjoyed his vigorous and stimulating approach. Question time produced some challenging retorts which were answered with great skill, enthusiasm and confidence by Mr. Burt. His lecture did much to give members an appreciation of the extent of his varied duties.

D.G.R.

#### Bletchley Centre

We are pleased to announce that we now have 82 members. Despite this, however, the attendance at the meeting in December was poor and many members missed a good illustrated talk on "The Television Network" given by Mr. W. L. Newman.

In November, although our meeting had to be cancelled at short notice, members had the opportunity of a visit to A.C. Delco Division of General Motors, and being the guests of the Foremans' Association for the evening.

The committee has been busy organizing a trip to Holland for the Bletchley Centre members, to see our Dutch colleagues at work and meet them socially. This will be by invitation of the Director-in-Chief of the Netherlands Postal and Telecommunications service and will be from 5-8 April 1962.

A technical reference library is being set up in the Centre, the committee having approved Mr. J. S. Salmon as the Hon. Librarian. So far over 60 books, pamphlets and catalogues for reference and of general interest have been obtained from a large number of firms and organizations.

Members may be interested to note that the Centre has been registered under the Mullard educational scheme and we can obtain much assistance for those who may wish to further their personal studies and hobbies in the electronics, radio and television fields.

The draft rules of the Centre were finally amended and approved in October and all members should now be in possession of a copy.

The committee feel satisfied and encouraged by the interest shown by the membership in the few activities which have been organized in the brief period since the Centre was started last June.

A.J.H.

#### Middlesbrough Centre

The Middlesbrough Centre's 1961 program started on 13 September 1961 with a talk entitled "The Electrical Engineer at Sea" by Commander J. C. Turnbull of I.C.I. The Commander described the layout of the electrical system of a ship and the maintenance problems at sea, punctuating his talk with his many experiences whilst on active service.

Local interest was the theme for the November meeting when Mr. P. Barton gave his talk "Tees Journey." Although the journey was described by a stranger to the area he nevertheless showed himself to be an authority on the subject. Mr. Barton showed us how the river, its life, and industry had changed throughout the last 100 years and to illustrate the talk he used some 40-50 slides, which included reproductions of old prints and documents, all of which he had prepared himself. An appreciative audience of nearly 30 members attended.

"American Visit" was the title of the December meeting given by Mr. J. S. Gill, Efficiency Engineer, Middlesbrough. This was a filmed record of an American holiday spent by Mr. Gill and his wife last year. The film taken by Mr. Gill showed many beauty spots and a commentary was given by the photographer. Some 25 members and wives attended and all agreed that it was a most entertaining evening.

A week later, 12 December, 15 members paid an evening visit to Messrs. Dorman Long Steel Works and the party were shown around one of the most modern steel plants in the country; the beam mill, for example, is some three-quarters of a mile in length. The whole process from the moulding of the ingots to the rolling of the beams was seen.

#### Leeds Centre

December brought once again the festive season and this year our annual dinner and dance was held at the Guildford Hotel, Leeds, where 133 people sat down to dinner, followed by a dance. An enjoyable evening was had by all. We are pleased to have with us Mr. E. Hopkinson, Area Engineer, Leeds and Mrs. Hopkinson, and Mr. A. K. Robinson, Regional Liaison Officer.

On 3 January, 25 of our members visited Tetley's brewery.

An evening visit was also made during January to the Yorkshire Copper Works, and in February Mr. M. C. Metcalfe gave a lecture on "Space flight."

E.B.B.

#### Dundee Centre

Our opening meeting of this session, a Saturday visit to Kirk-o'-Shotts, was very successful; 42 members and friends were shown over the Post Office, B.B.C. and I.T.A. television stations.

Due to most inclement weather our visit to the Royal Observer Corps, Craigiebarns, had to be cancelled, but we managed a most interesting visit to the North British Relay Station in October. Also in October we had a show of films, supplied by Mullard, Ltd., in the new telephone exchange Perth.

On 7 November, Mr. D. Wilson, one of our Assistant Engineers who had been on an exchange visit to Holland, gave a very interesting talk on "Dutch Telecommunications."

On 23 November, Mr. H. E. James of J. Keillor & Sons spoke on "Time and Motion Study." This was an excellent talk which was thoroughly enjoyed.

The last meeting of the year was of a lighter nature when Mr. C. Robertson of Newport-on-Tay gave an illustrated talk on "Continental Camping."

A visit was made to the Radiology Department of the Dundee Royal Infirmary in February.

Mr. K. F. Jalland, our Area Engineer, spoke on "Trunk Circuits over Microwave Links" at the meeting on 13 March. Of additional interest at this meeting was the presentation by Mr. R. J. Hines, Chief Regional Engineer, to Mr. J. S. R. Lawson of the Institution Certificate for his

paper "Microwaves for the Layman" and the Silver Medal of the City and Guilds for the Radio C examination results.

#### Aberdeen Centre

The 1961-62 session commenced with a talk on "The Water Supply to Aberdeen" which was followed by a visit to the filter beds and intakes on Deeside. Talks on the following subjects were also given during the session: "Microwaves for the Layman," "The 10-Line Semi-Electronic Exchange for Radio Systems 8/3," "The Slide-Rule," "The Conversion from Steam to Diesel Working on British Railways," and "The Television Network Switching Centre."

Visits have been tentatively arranged for the remainder of the session.

J.B.L.

#### Cornwall Centre

The Winter program began in October with a lecture by Mr. Hubber, Area Engineer of the South-Western Electricity Board, who read a paper on "Power Distribution in Cornwall."

In November Mr. Taylor of Dollis Hill Research Station read a paper on "The use of Microwave Aerials as applied to Satellite Communications." Mr. Taylor also brought along some excellent coloured slides of various microwave aerials in operation in the United States and included in his paper the part that the station at Goonhilly Downs in Cornwall will play when the first communication satellite is launched.

A film show on "Cornish Steam Engines" was arranged for December and we are grateful to Mr. S. T. Stevens for projecting these films for us and also including in the program a colour film which he had previously taken of "Cornish Industries."

In January Mr. Procter, O.B.E., C.R.E., London Telecommunications Region, made his annual visit to the Cornwall Centre. His paper this year was entitled "Space Communications." In February Mr. Longman, Resident Engineer of Hinkley Point Atomic Power Station, gave us a paper on "The Peaceful Uses of Atomic Energy." This was followed in March by Mr. Warren, Director of the Marine Biological Museum, Plymouth, who read a paper on "Marine Life."

The annual dinner and dance was also held in March.

A.R.B.

#### London Centre

At a presentation held in Fleet Building on Tuesday, 23 January, the City Area Telephone Manager, Mr. Markby, presented Mr. G. E. Gorrings with a certificate and cheque for seven guineas for his paper "The Electronic Digital Computer," which had merited the award of first prize from the Institution for the best paper submitted by the local Centre Committees.

Now an Assistant Engineer in the Engineering Department, Mr. Gorrings was at the time of writing the paper a Technical Officer in City Area, London Telecommunications Region.

The January talk "The Pressurization of Local Cables" was given before an audience of 80 members by Mr. J. F. Craggs, who described, with the aid of displays and working models, present techniques and the latest developments in the pressurization of the local cable network.

A visit took place in January to the Middlesex Hospital. The party saw the X-ray film-processing unit, where automatic machines are in use which develop, fix, wash and dry the films in seven minutes. The specialized methods of handling and storage of radioactive materials and certain aspects of electro-medical treatment, including one of the latest deep-therapy machines, which employs a cobalt isotope, were seen.

The final talk of his career was given before an audience of nearly 200 members by Mr. W. S. Procter, the Chief Regional Engineer of the L.T.R., at the Assembly Hall, Fleet Building on Thursday, 8 February. To use his own words his talk "went off with a bang," when he launched a dummy satellite into the hall amid clouds of smoke. Mr. Procter was giving a practical demonstration, showing how satellites will be used to bounce radio signals across the Atlantic, to illustrate his subject, "Global Communications." He spoke about some of the technical considerations of such a task, and mentioned, in particular, the satellite tracking station which is nearing completion at Goonhilly Down, Cornwall. An interesting historical parallel, he said, was that 60 years ago Marconi made his first radio transmissions from Poldu, not far away. Although regular live-television programmes from across the Atlantic will not take place for several years, short news items may be possible in the near future.

At the conclusion of his talk Mr. Procter accepted honorary membership of the Associate Section, and was presented with the London Centre tie and square.

E. S. G.

---

## Book Review

"Differential Equations for Engineers and Scientists."  
C. G. Lambe, B.A., Ph.D., and C. J. Tranter, O.B.E.,  
M.A., D.Sc. The English Universities Press, Ltd.  
xi + 372 pp. 75 ill. 30s.

Differential equations are among the more intangible mathematical entities that require the attention of engineers and scientists, and books on the subject intended for pure mathematicians make difficult reading for the non-specialist. They tend to concentrate on such matters as proving existence theorems, investigating the completeness of solutions, the convergence of series solutions, and all the other topics that give the specialist his sleepless nights. When the engineer or scientist has reached the stage of triumphantly producing what he fondly believes is the right differential equation to describe his problem he is in no need of existence theorems—he would gamble his last pittance that his equation has a solution—all he wants is to find it, by hook or by crook.

For this large class of people the present volume will be

most welcome. The outlook is typified by the following quotation from the introduction to the chapter on relaxation methods: "It is not proposed to discuss the more mathematical aspects of the relaxation method. . . . It is sufficient to say here that the method outlined in this chapter works in practice and that its great power has been clearly demonstrated by the many important engineering and physical problems which have been recently solved by its use." What could be fairer than this?

The writers are obviously two very experienced teachers of mathematics and the book is a pleasure to read. It follows the traditional pattern of subject matter in the first seven chapters (first order equations and then various brands of linear equations), and then in the remaining four chapters deals with, respectively, integral transforms, graphical and numerical methods, the relaxation method, and non-linear equations. The general level of treatment corresponds to that required for an engineering or physics degree. It is reasonably priced, clearly printed and can be recommended to any student of the subject.

H. J. O.

# Staff Changes

## Promotions

Name	Region, etc.	Date	Name	Region, etc.	Date
<i>Deputy Chief Scientific Officer to Deputy Director of Research</i>			<i>Assistant Engineer (Open Competition)—continued</i>		
Metson, G. H.	.. E.-in-C.O. ..	1.2.62	Kendall, J. P.	.. E.-in-C.O. ..	22.8.61
<i>Regional Engineer to Staff Engineer</i>			Askew, A. R. C.	.. E.-in-C.O. ..	22.8.61
Boocock, R. O.	.. H.C. Reg. to E.-in-C.O. ..	14.2.62	Knowles, D.	.. E.-in-C.O. ..	30.10.61
<i>Senior Executive Engineer to Assistant Staff Engineer</i>			Bailey, K. E.	.. E.-in-C.O. ..	26.6.61
Horsfield, B. R.	.. E.-in-C.O. ..	9.11.61	<i>Assistant Engineer (Limited Competition)</i>		
Davidson, C. F.	.. E.-in-C.O. ..	23.11.61	Butler, H. K.	.. Mid. Reg. ..	8.5.61
<i>Area Engineer to Regional Engineer</i>			Turner, A. S.	.. Mid. Reg. ..	8.5.61
Stevenson, H. C.	.. Scot. to N.W. Reg. ..	4.12.61	Ogilvy, A. W.	.. Scot. ..	8.5.61
<i>Efficiency Engineer to Regional Engineer</i>			Packham, B. V.	.. H.C. Reg. to L.T. Reg. ..	8.5.61
Palmer, R. N.	.. W.B.C. to Scot. ..	27.11.61	Nichols, J. H.	.. H.C. Reg. to W.B.C. ..	8.5.61
<i>Executive Engineer to Senior Executive Engineer</i>			Griffiths, D. H.	.. W.B.C. to E.T.E. ..	8.5.61
Forbes, E. D.	.. E.-in-C.O. to Factories Department ..	31.10.61	Procter-Blain, A. J.	.. N.E. Reg. ..	8.5.61
Belk, J. L.	.. L.T. Reg. to E.-in-C.O. ..	20.11.61	Fulton, J. I.	.. E.-in-C.O. ..	8.5.61
Bearham, D. R.	.. L.T. Reg. to E.-in-C.O. ..	11.12.61	Rowell, G. N.	.. S.W. Reg. ..	8.5.61
Newell, E.	.. E.-in-C.O. ..	11.12.61	Edwards, R. J.	.. Mid. Reg. ..	8.5.61
Whittaker, J. W.	.. L.T. Reg. to E.-in-C.O. ..	28.12.61	Smith, T. M.	.. N.E. Reg. to Mid. Reg. ..	8.5.61
Lowe, W. T.	.. E.-in-C.O. ..	18.12.61	Hobster, B. D.	.. N.W. Reg. to E.-in-C.O. ..	8.5.61
<i>Executive Engineer (Open Competition)</i>			Jolly, A. M.	.. H.C. Reg. ..	8.5.61
Knight, R. A.	.. E.-in-C.O. ..	9.10.61	Crowther, G. H.	.. N.E. Reg. to N.W. Reg. ..	8.5.61
Brown, R. J.	.. E.-in-C.O. ..	15.11.61	Young, P. S. J.	.. H.C. Reg. ..	8.5.61
<i>Assistant Engineer to Executive Engineer</i>			Nicoll, T. R.	.. L.T. Reg. ..	29.5.61
Bridger, F. J.	.. H.C. Reg. ..	11.10.61	Gill, B. S.	.. S.W. Reg. ..	29.5.61
Teale, J.	.. N.E. Reg. ..	11.10.61	Kirby, A.	.. E.-in-C.O. ..	29.5.61
Whiteley, L.	.. N.E. Reg. ..	11.10.61	Male, N. R.	.. E.T.E. to E.-in-C.O. ..	29.5.61
Murray, F.	.. N.E. Reg. ..	11.10.61	Godden, B. F.	.. H.C. Reg. to E.-in-C.O. ..	29.5.61
Hart, G. B. C.	.. N.E. Reg. ..	11.10.61	Way, V. G. W.	.. E.-in-C.O. ..	29.5.61
Lamont, P. A.	.. Scot. to Mid. Reg. ..	30.10.61	Crump, N. G.	.. E.-in-C.O. ..	29.5.61
Friday, F. F.	.. Mid. Reg. to E.-in-C.O. ..	1.11.61	Kirby, D. J.	.. E.-in-C.O. to L.T. Reg. ..	29.5.61
Allan, M. W. J.	.. Scot. ..	12.10.61	Mullins, D. W. J.	.. L.T. Reg. ..	29.5.61
Kimber, R. T.	.. S.W. Reg. ..	30.10.61	Flanagan, J.	.. Scot. ..	29.5.61
Esseen, D. O.	.. L. T.Reg. to E.-in-C.O. ..	20.11.61	Lock, R. D.	.. E.-in-C.O. ..	12.6.61
Tungate, R. G.	.. Mid. Reg. ..	22.11.61	Miles, D. V.	.. H.C. Reg. to E.-in-C.O. ..	29.5.61
Pagett, F. A. T.	.. Mid. Reg. to N. W. Reg. ..	28.6.61	Monro, D. I.	.. E.-in-C.O. ..	29.5.61
Heward, F. C.	.. E.-in-C.O. ..	6.10.61	Stephens, G. G.	.. L.T. Reg. to E.-in-C.O. ..	29.5.61
Cole, A. C.	.. E.-in-C.O. ..	6.10.61	Platt, S. M. K.	.. E.-in-C.O. ..	29.5.61
Rowbotham, F. J.	.. N.I. ..	7.9.61	Coackley, R.	.. E.-in-C.O. ..	29.5.61
Heathcote, S.	.. Mid. Reg. ..	7.9.61	Robb, J. W.	.. Scot. to E.-in-C.O. ..	29.5.61
Veasey, D. W.	.. Mid. Reg. ..	7.9.61	Mason, J.	.. S.W. Reg. ..	12.6.61
Pearce, F. W.	.. H.C. Reg. to S.W. Reg. ..	6.11.61	McKay, N. P.	.. L.T. Reg. to E.-in-C.O. ..	12.6.61
Wood, H. J.	.. N.W. Reg. ..	22.11.61	Brooks-Johnson, F. L.	.. L.T. Reg. ..	12.6.61
Williams, N. R.	.. H.C. Reg. to N.E. Reg. ..	4.12.61	Sheehan, D.	.. W.B.C. to E.-in-C.O. ..	12.6.61
Flanagan, E. G.	.. E.-in-C.O. ..	11.12.61	Canham, A. O.	.. L.T. Reg. ..	12.6.61
Lee, L. R.	.. E.-in-C.O. ..	11.12.61	Birch, G. M.	.. L.T. Reg. ..	12.6.61
Fidler, R. G.	.. E.-in-C.O. ..	18.12.61	Walkden, M. R.	.. N.W. Reg. to E.-in-C.O. ..	29.5.61
Iles, S. H.	.. E.-in-C.O. ..	18.12.61	Morris, R.	.. H.C. Reg. to L.T. Reg. ..	12.6.61
Daniels, E. E.	.. E.-in-C.O. ..	18.12.61	Wood, C. D.	.. L.T. Reg. to E.-in-C.O. ..	12.6.61
Redfern, A. E.	.. E.-in-C.O. ..	18.12.61	Power, W. L.	.. S.W. Reg. to E.-in-C.O. ..	12.6.61
Edwards, R. G.	.. E.-in-C.O. ..	18.12.61	Crooks, K. R.	.. L.T. Reg. ..	29.5.61
Stubbington, C. J.	.. H.C. Reg. ..	7.12.61	Buffin, J. D.	.. H.C. Reg. to E.-in-C.O. ..	12.6.61
Osborne, A. B.	.. L.T. Reg. ..	15.12.61	Adams, T. W.	.. L.T. Reg. ..	12.6.61
Peachey, M.	.. W.B.C. to S.W. Reg. ..	1.1.62	Jupp, G. F.	.. L.T. Reg. ..	12.6.61
Yeatman, R.A.	.. H.C. Reg. to N.W. Reg. ..	15.1.62	Berry, G.	.. N.E. Reg. to E.-in-C.O. ..	12.6.61
Helps, W. F.	.. L.T. Reg. to E.-in-C.O. ..	3.1.62	Probert, P. E.	.. E.-in-C.O. ..	12.6.61
Frecknall, F. H. L.	.. E.-in-C.O. ..	3.1.62	Boardman, R. T.	.. E.-in-C.O. ..	12.6.61
Whittle, A. D.	.. L.T. Reg. to E.-in-C.O. ..	3.1.62	Wilkinson, K.	.. N.W. Reg. to E.-in-C.O. ..	12.6.61
Taylor, N.	.. E.-in-C.O. ..	3.1.62	Gasgoyne, P. F.	.. Mid. Reg. to E.-in-C.O. ..	12.6.61
Blakey, H.	.. E.-in-C.O. ..	3.1.62	Elliott, B. A.	.. N.W. Reg. to E.-in-C.O. ..	3.7.61
Price, C. K.	.. E.-in-C.O. ..	3.1.62	Walker, W.	.. Scot. to E.-in-C.O. ..	10.7.61
<i>Assistant Engineer (Open Competition)</i>			Day, B.	.. N.E. Reg. to Mid. Reg. ..	11.9.61
Burrows, K. G.	.. E.-in-C.O. ..	22.8.61	<i>Inspector to Assistant Engineer</i>		
Shean, P. G. T.	.. E.-in-C.O. ..	18.9.61	Maxwell, J. W.	.. Scot. ..	10.8.61
Gargan, J.	.. E.-in-C.O. ..	22.8.61	Gray, R. N.	.. H.C. Reg. ..	19.10.61
			Lambert, R. G.	.. Mid. Reg. ..	1.11.61
			Ware, H.	.. S.W. Reg. ..	9.10.61
			Bell, S.	.. N.I. ..	5.10.61
			Clarke, J.	.. N.I. ..	5.10.61
			Williams, K. F.	.. W.B.C. ..	23.11.61
			<i>Technical Officer to Assistant Engineer</i>		
			White, C.	.. N.W. Reg. ..	4.9.61
			Young, G. D.	.. Scot. ..	10.8.61

Promotions—continued

Name	Region, etc.	Date	Name	Region, etc.	Date
<i>Technical Officer to Assistant Engineer—continued</i>			<i>Technical Officer to Inspector</i>		
Kitchen, D. C.	H.C. Reg.	9.8.61	Wylie, J.	Scot.	23.10.61
Wright, A. A.	H.C. Reg.	18.9.61	Jeffreys, T. R.	W.B.C.	2.10.61
Bond, M. I.	H.C. Reg.	4.9.61	Bennington, H. F.	W.B.C.	27.9.61
Parrish, I. P.	H.C. Reg.	22.9.61	Chappell, B. W.	W.B.C.	2.10.61
Trott, N. C.	W.B.C.	30.10.61	Gatward, A. E.	L.T. Reg.	23.10.61
Clements, A. W.	H.C. Reg.	4.9.61	Watson, G. C.	L.T. Reg.	23.10.61
Read, C. W.	S.W. Reg.	4.10.61	Kerrison, L.	L.T. Reg.	23.10.61
Coles, D. C.	H.C. Reg.	20.10.61	Dadd, K. S.	L.T. Reg.	23.10.61
Parker, H. G.	N.W. Reg.	2.10.61	Lacey, D. H.	L.T. Reg.	23.10.61
Bolton, V. R.	N.W. Reg.	25.9.61	Foale, J. D. R.	L.T. Reg.	23.10.61
Jones, D. H.	N.W. Reg.	24.10.61	Tipple, V. G.	L.T. Reg.	23.10.61
Jones, H. H.	N.W. Reg.	18.10.61	Gough, R.	L.T. Reg.	23.10.61
Genner, P.	Mid. Reg.	1.11.61	Neill, H. W.	N.I.	5.10.61
Powell, N. G.	Mid. Reg.	1.11.61	McMorris, R. J.	N.I.	5.10.61
Chadd, R. A.	E-in-C.O.	30.10.61	Rocks, T. A.	N.I.	5.10.61
Evered, J. M.	N.E. Reg.	3.11.61			
Towler, C.	N.E. Reg.	3.11.61	<i>Technician I to Inspector</i>		
Campbell, J.	L.T. Reg.	23.10.61	Robinson, M.	E-in-C.O.	13.11.61
Doherty, J. F.	L.T. Reg.	23.10.61	Towell, W. G.	E-in-C.O.	13.11.61
Beardow, C. V.	L.T. Reg.	23.10.61	Spruce, S. G.	L.T. Reg.	23.10.61
Lewis, E. J.	L.T. Reg.	23.10.61			
Arnold, B. R.	L.T. Reg.	9.11.61	<i>Senior Scientific Officer (Open Competition)</i>		
Day, J. F.	L.T. Reg.	23.10.61	Chakraborty, D.	E-in-C.O.	6.10.61
Watkinson, S. J.	L.T. Reg.	9.11.61			
Elliott, R. G. M.	L.T. Reg.	9.11.61	<i>Scientific Officer (Open Competition)</i>		
Walter, C. J.	L.T. Reg.	23.10.61	Mellor, R. J. T.	E-in-C.O.	7.11.61
Reeve, L.	L.T. Reg.	9.11.61			
Story, F. W.	L.T. Reg.	23.10.61	<i>Assistant Experimental Officer (Open Competition)</i>		
Bignall, V. J.	L.T. Reg.	23.10.61	Houghton, G. F.	E-in-C.O.	2.10.61
Murphy, F. W. K.	L.T. Reg.	23.10.61	Jacobs, F. G.	E-in-C.O.	15.11.61
Baldwin, G. M.	L.T. Reg.	23.10.61	Moore, P.	E-in-C.O.	6.11.61
Chadwick, J. G.	L.T. Reg.	23.10.61			
Robinson, G. T.	W.B.C.	1.11.61	<i>Technical Assistant II to Technical Assistant I</i>		
Briers, N. C.	W.B.C.	25.9.61	Rackley, C. E.	E-in-C.O.	6.12.61
Marshall, D.	Scot.	24.10.61			
Watters, T. C.	Scot.	24.10.61	<i>Chief Draughtsman to Inspector of Drawing Offices</i>		
Gibson, H.	N.I.	5.10.61	Jury, R. J.	E-in-C.O.	1.11.61
Elborn, D. S.	N.I.	5.10.61			
Naylor, R. T. A.	L.T. Reg.	14.11.61	<i>Draughtsman to Leading Draughtsman</i>		
Shaw, T. N.	N.W. Reg.	22.11.61	Edwards, F. H.	L.T. Reg.	13.9.61
Robinson, B. G.	N.E. Reg.	21.12.61	Molyneux, G. C.	E-in-C.O.	4.12.61
Appleton, R.	N.E. Reg.	21.12.61	Matheson, L. M.	E-in-C.O.	4.12.61
Burkitt, L. W.	N.E. Reg.	21.12.61	Smith, H. C. W.	E-in-C.O.	4.12.61
Ryder, C. E.	L.T. Reg.	22.12.61	Paynter, J. A. N.	E-in-C.O.	4.12.61
Thompson, L. J.	L.T. Reg.	22.12.61	Leppington, P. M. J.	E-in-C.O.	4.12.61
Appleford, R. F.	L.T. Reg.	22.12.61	Bullivant, D. J.	E-in-C.O.	4.12.61
Wray, L.	L.T. Reg.	1.1.62	Hawkins, A. G.	E-in-C.O.	4.12.61
Willis, W. J. S.	L.T. Reg.	22.12.61	Morris, J. S.	E-in-C.O.	4.12.61
Palmer, R. J.	L.T. Reg.	22.12.61			
Cassidy, G. H.	L.T. Reg.	22.12.61	<i>Clerical Officer to Executive Officer</i>		
Smith, S. W.	L.T. Reg.	22.12.61	Mojon, D. (Miss)	E-in-C.O.	23.10.61
Donnelly, J.	N.I.	28.11.61	Smith, R. A.	E-in-C.O.	16.10.61
Hume, B. J.	N.I.	14.12.61	White, J. P.	E-in-C.O.	28.12.61
Osbaldeston, R.	N.W. Reg.	28.12.61			
Butler, A. R.	N.W. Reg.	28.12.61			
Jones, R.	N.W. Reg.	28.12.61			
<i>Draughtsman to Assistant Engineer</i>					
Woods, F. J.	H.C. Reg.	11.10.61			
Cutts, G. F.	H.C. Reg.	9.8.61			
Johnston, L. A.	N.I.	5.10.61			

Retirements and Resignations

Name	Region, etc.	Date	Name	Region, etc.	Date
<i>Deputy Director of Research</i>			<i>Area Engineer</i>		
Richards, C. E.	E-in-C.O.	31.12.61	Allen, W. C.	E.T.E.	7.11.61
<i>Staff Engineer</i>			<i>Senior Executive Engineer</i>		
Harbottle, H. R.	E-in-C.O.	6.2.62	Partridge, F. V.	L.T. Reg.	2.10.61
<i>Assistant Staff Engineer</i>			<i>Executive Engineer</i>		
Dunford, L. G.	E-in-C.O.	31.12.61	Middleditch, E. G. H.	E.T.E.	21.8.61
			Lowton, J.	N.W. Reg.	31.10.61

Retirements and Resignations—continued

Name	Region, etc.	Date	Name	Region, etc.	Date
<i>Executive Engineer—continued</i>			<i>Assistant Engineer—continued</i>		
Fox, G.	W.B.C.	13.9.61	Hartog, W. B.	E.-in-C.O.	31.12.61
Hunter, W. J.	N.E. Reg.	2.10.61	(Resigned)		
Chapman, J. F.	N.E. Reg.	9.9.61	<i>Inspector</i>		
Emery, E. A.	L.T. Reg.	14.11.61	Martin, H. J.	L.T. Reg.	2.10.61
Leversuch, E. J.	L.T. Reg.	30.11.61	Jennings, A. R. E.	S.W. Reg.	25.10.61
Ellis, W.	N.E. Reg.	30.11.61	<i>Temporary Senior Scientific Officer</i>		
Came, C. H.	S.W. Reg.	10.11.61	McKeon, A. (Resigned)	E.-in-C.O.	31.10.61
Wiltshire, R. E.	S.W. Reg.	16.11.61	<i>Assistant Experimental Officer</i>		
Birrell, R. C.	Scot.	11.11.61	James, B. E. (Mrs.)	E.-in-C.O.	31.10.61
Mullard, R.	E.-in-C.O.	8.12.61	(Resigned)		
<i>Assistant Engineer</i>			<i>Temporary Assistant Experimental Officer</i>		
De Freitas, J. C.	E.-in-C.O.	30.11.61	Peters, B. W. (Resigned)	E.-in-C.O.	24.11.61
(Resigned)			Parry, M. J. (Resigned)	E.-in-C.O.	31.12.61
Kelly, W. C.	Scot.	10.8.61	<i>Assistant (Scientific)</i>		
Hard, A. A.	H.C. Reg.	5.9.61	Parry, H. W. (Resigned)	E.-in-C.O.	31.12.61
Halsall, N. J.	N.W. Reg.	18.10.61	<i>Temporary Assistant (Scientific)</i>		
Wright, F. C.	N.W. Reg.	24.10.61	Rawle, F. W. H.	E.-in-C.O.	17.11.61
Mowbray, A. H.	E.-in-C.O.	1.11.61	(Resigned)		
Ryder, F.	N.W. Reg.	1.11.61	Goodman, R. W.	E.-in-C.O.	19.10.61
Hastie, T.	Scot.	14.11.61	(Resigned)		
Cowley, G.	N.E. Reg.	17.11.61	<i>Assistant Regional Motor Transport Officer</i>		
Allaway, S. A.	L.T. Reg.	18.11.61	Lingwood, A. L.	H.C. Reg.	25.9.61
Belk, A.	N.E. Reg.	29.11.61	<i>Chief Draughtsman</i>		
Englefield-Bishop, C. G.	E.-in-C.O.	30.11.61	Owles, F. H.	E.-in-C.O.	31.10.61
Cordell, A. A.	L.T. Reg.	30.11.61	<i>Senior Draughtsman</i>		
Marlow, J. A.	L.T. Reg.	3.11.61	Lipscombe, C. A. D.	E.-in-C.O.	16.11.61
(Resigned)			Wright, L. J.*	E.-in-C.O.	31.12.61
Patterson, R.	N.I.	17.9.61	<i>Leading Draughtsman</i>		
Weidhoff, E. A.	L.T. Reg.	9.10.61	Henton, R.	H.C. Reg.	8.10.61
Sharp, E.	N.E. Reg.	20.10.61			
Large, G. V.	W.B.C.	28.10.61			
Parker, A. S.	Mid. Reg.	28.10.61			
Llewellyn, W.	W.B.C.	31.10.61			
Body, G. E. H.	S.W. Reg.	9.11.61			
Gwynn, W. P.	E.T.E.	30.11.61			
Darby, G. F.	L.T. Reg.	4.12.61			
Clarke, P.	E.-in-C.O.	13.12.61			

\* Mr. L. J. Wright is continuing as a disestablished officer with E.-in-C.O.

Transfers

Name	Region, etc.	Date	Name	Region, etc.	Date
<i>Assistant Staff Engineer</i>			<i>Assistant Engineer</i>		
Eley, A. C.	Joint P.O./M.O.W. R. & D.G. to E.-in-C.O.	1.11.61	Myers, H. B.	Mid. Reg. to E.-in-C.O.	2.10.61
<i>Area Engineer</i>			Ryles, K. V.	E.-in-C.O. to Mid. Reg.	16.10.61
Gilbey, P. D.	N.E. Reg. to Trinidad	3.12.61	Crawford, A.	E.-in-C.O. to International Civil Aviation Organization	15.11.61
<i>Senior Executive Engineer</i>			Clark, L.	E.-in-C.O. to Trinidad	2.12.61
Partington, E. V.	E.-in-C.O. to L.T. Reg.	3.10.61	Ellis, G.	E.-in-C.O. to Trinidad	2.12.61
Haley, G.	Factories Department to E.-in-C.O.	23.10.61	Dutton, K. W.	E.-in-C.O. to H.C. Reg.	4.12.61
Weston, F. T.	E.-in-C.O. to H.C. Reg.	4.12.61	Stacey, P. J.	E.-in-C.O. to Royal Naval Scientific Service	11.12.61
<i>Executive Engineer</i>			Askew, A. R. C.	E.-in-C.O. to N.W. Reg.	11.12.61
Sinnicks, A. C.	Approved Employment to H.C. Reg.	19.10.61	Ainsworth, C. N. L.	Nigeria to Mid. Reg.	18.12.61
Harris, W. E. G.	Scot. to W.B.C.	13.11.61	<i>Senior Scientific Officer</i>		
Ferguson, O. A. K.	E.-in-C.O. to S.W. Reg.	10.11.61	Champion, J. A.	E.-in-C.O. to D.S.I.R.	31.10.61
Webb, A. J.	E.-in-C.O. to L.T. Reg.	15.11.61	<i>Assistant (Scientific)</i>		
North, P. W. F.	E.-in-C.O. to L.T. Reg.	18.12.61	Agacy, R. L.	E.-in-C.O. to D.S.I.R.	1.10.61
			<i>Executive Officer</i>		
			Cross, F. H.	L.T. Reg. to E.-in-C.O.	10.11.61
			Jeffrey, D. G.	E.-in-C.O. to L.P. Reg.	18.11.61

Deaths

Name	Region, etc.	Date	Name	Region, etc.	Date
<i>Assistant Engineer</i>			<i>Leading Draughtsman</i>		
Leyland, A.	N.W. Reg.	24.10.61	Bottomley, F.	E.-in-C.O.	29.11.61
Shepherd, A. M.	E.-in-C.O.	28.12.61	Harris, R. A.	Mid. Reg.	8.12.61



# Papers and Articles on Telecommunications and Other Scientific Subjects

The following is a list of the authors, titles and places of publication of papers and articles written by Post Office staff (sometimes in association with members of other organizations) and published during 1961.

- ALLAN, A. F. G. Cable Damage by Roadwork. *Post Office Telecommunications Journal*, Vol. 13, p. 233, Winter 1961.
- BAKER, D. Problème du Dégazage et des Défauts d'étanchéité des Boîtiers de Transistors. *L'onde Electrique*, Vol. XLI, p. 408, Apr. 1961.
- BARKER, H. Meeting Increasing Demand for Inland Trunk Circuits. *Post Office Telecommunications Journal*, Vol. 13, p. 224, Winter 1961.
- BASSETT, H. G. Novel Transformer Suitable for the Parallel Operation of Current-Driven Devices. *Radio and Electronic Components*, Vol. 2, p. 129, Mar. 1961.
- BATEY, H. Work Function Measurements on the Platinum Alloys of the Alkaline-Earth Metals. *Proceedings I.E.E.*, Vol. 108, Part B, p. 468, July 1961.
- BATEY, H., see METSON, G. H.
- BENNETT, R. O., and STRINGER, J. B. Acceptance Trials of Computers for Government Use. *The Computer Journal*, Vol. 4, p. 185, Oct. 1961.
- BOWCOTT, H. J., and CLEAVER, A. J. Corrosion of Electrical Components by their Atmospheric Environment. *Proceedings I.E.E.*, Paper No. 3624, June 1961 (Vol. 108, Part B, Supplement 22).
- CARASSO, J. I., see FAKTOR, M. M.
- CLEAVER, A. J. Corrosion Problems in a Submarine Telephone Cable having an Aluminium Outer Coaxial Conductor. Read at First International Congress on Metallic Corrosion, London, Apr. 1961.
- CLEAVER, A. J., see BOWCOTT, H. J.
- COBBE, D. W. R. Railway Electrification and Post Office Lines. *Post Office Telecommunications Journal*, Vol. 13, p. 126, Summer 1961.
- CORKE, R. L., see WATT-CARTER, D. E.
- CROISDALE, A. C. Error Rates and Error Detection on Telegraph Circuits. *I.R.E. Transactions and Communications Systems*, Vol. CS-9, p. 28, Mar. 1961.
- DAGLISH, H. N. Electron Emission from Cold Magnesium Oxide. *Proceedings I.E.E.*, Vol. 108, Part B, p. 103, Jan. 1961.
- DAVISON, G. N., see PHILLIPS, R. S.
- FAKTOR, M. M., and CARASSO, J. I. An All-Glass Microbalance. *Chemistry and Industry*, Vol. 28, p. 1,062, 15 July 1961.
- FAUT, G. C. M.,\* MARTONY, J.,\* RENGMAN, U.,\* RISBERG, A.,\* and HOLMES, J. N. Recent Progress in Formant Synthesis of Connected Speech. Contributed paper to the Sixty-First Meeting of the Acoustical Society of America, May 1961.
- FLOWERS, T. H. Electronic Exchange Research and Development in the United Kingdom. Conference on New Developments in Electrical Traction and Telecommunications in Great Britain, Warsaw, 21-22 Mar. 1961 (Association of Polish Electrical Engineers (S.E.P.)).
- FLOWERS, T. H. Electronic Telephone Exchanges. *Transaction of the Society of Instrument Technology*, Vol. 13, p. 191, Sept. 1961.
- FLOWERS, T. H., and FORSHAW, G.† British J.E.R.C. Development of Electronic Switching. *British Communications and Electronics*, Vol. 8, p. 208, July 1961.
- FLOYD, C. F., see TAYLOR, F. J. D., and others.
- FORSHAW, G., see FLOWERS, T. H.
- FREEBODY, J. W. Some General Comments on the Reliability of Mechanical Parts of Data Processing Systems. Proceedings of the Informal Discussion on the Reliability of Mechanical Engineering Plants of Data Processing Systems, London, p. 6, Jan. 1961 (Published by the Institution of Mechanical Engineers).
- GILL, J. S. A Study of the Requirements for Excitation Control in Synthetic Speech. Proceedings of the Third International Congress on Acoustics, Stuttgart 1959, Vol. 1, p. 221 (Published by Elsevier 1961).
- GILL, J. S. A Versatile Method for Short-term Spectrum Analysis in Real-time. *Nature*, Vol. 189, p. 117, 14 Jan. 1961.
- GILL, J. S. Automatic Extraction of the Excitation Function of Speech with Particular Reference to the Use of Correlation Methods. Proceedings of the Third International Congress on Acoustics, Stuttgart 1959, Vol. 1, p. 217 (Published by Elsevier, 1961).
- GILL, J. S. Recent Research on Methods for Automatic Estimation of Vocal Excitation. Fourth International Congress on Phonetic Sciences, Helsinki, 1961.
- HALSEY, R. J. Telecommunications with Particular Reference to Cables and Their Requirements. *Transactions and Proceedings of the Institution of Rubber Industry*, Vol. 37, p. 59, June 1961.
- HAMER, R. Long-Distance Waveguide Transmission, Parts 1 and 2. *Electronic Engineering*, Vol. 33, pp. 218 and 279, Apr. and May 1961.
- HAMER, R. Radio-Frequency Interference in Multi-Channel Telephony F.M. Radio Systems. *Proceedings I.E.E.*, Vol. 108, Part B, p. 75, Jan. 1961.

- HAMER, R., and WILKINSON, R. G. V.H.F. Broad-Band Variable Group-Delay Equalizers. *Electronic Engineering*, Vol. 33, p. 506, Aug. 1961.
- HENDERSON, J. C. Improved Reflection Diffraction Holder for Electron Microscope. *Journal of Scientific Instruments*, Vol. 38, p. 453, Nov. 1961.
- HOLMES, J. N., see FAUT, G. C. M., and others.
- HOLMES, J. N., see SHEARME, J. N.
- HOLMES, J. N., see SWAFFIELD, J., and others.
- KELLY, P. T. F. Circuits for International Civil Aviation. *Post Office Telecommunications Journal*, Vol. 13, p. 189, Autumn 1961.
- LEWIS, N. W. Line-Spread Functions of Photographic Emulsions. *Nature*, Vol. 189, p. 909, 18 Mar. 1961.
- LITTLE, S. J. Electrical Protection of Telecommunications Plant. *Post Office Telecommunications Journal*, Vol. 13, p. 182, Autumn 1961.
- LOWE, W. T. A Telephone for Subscribers with Weak Voices. *Post Office Telecommunications Journal*, Vol. 13, p. 243, Winter 1961.
- LOWE, W. T. Hearing-Aid Telephones. *Post Office Magazine*, Vol. 22, p. 213, July 1961.
- LYNCH, A. C., see NEW, A. A.
- MARKS, D. J. Trunk Circuits for S.T.D. in the Director Areas. *Post Office Telecommunications Journal*, Vol. 13, p. 211, Winter 1961.
- MARTONY, J., see FAUT, G. C. M., and others.
- METSON, G. H. Conductivity of Oxide Cathodes, Part 10. Spontaneous Generation of Negative Ions. I.E.E. Monograph No. 443E, May 1961 (*Proceedings I.E.E.*, Vol. 108B, p. 471, July 1961).
- METSON, G. H., and BATEY, H. Conductivity of Oxide Cathodes, Part II. Thermal Stability of the Alkaline-Earth Oxides. I.E.E. Monograph No. 444E, May 1961 (*Proceedings I.E.E.*, Vol. 108B, p. 471, July 1961).
- METSON, G. H. Conductivity of Oxide Cathodes, Part 12. Influence of Strontium Ion Migration on Matrix Conductivity. I.E.E. Monograph No. 473E, Oct. 1961 (*Proceedings I.E.E.*, Vol. 108B, p. 672, Nov. 1961).
- NEW, A. A. Principles of Acceleration of Life Tests of Electronic Components. Read at the First International Congress on Components and Materials used in Electronic Engineering, I.E.E., 2-16 June 1961.
- NEW, A. A. Some Mechanisms of Failure of Capacitors with Mica Dielectrics. Read at the First International Congress on Components and Materials used in Electronic Engineering, I.E.E., 2-16 June 1961.
- NEW, A. A., and LYNCH, A. C. The Failure of Metallized-Paper Capacitors used with Large Series Resistances. Read at the First International Congress on Components and Materials used in Electronic Engineering, I.E.E., 2-16 June 1961.
- PHILLIPS, R. S., and DAVISON, G. N. Machine Sorting Gives a Better Service (Unsigned research report). *Engineering* Vol. 191, p. 910, 30 June 1961.
- PHILLIPS, R. S., and DAVISON, G. N. Mechanizing the Postal Service. *Journal I.E.E.*, Vol. 7, p. 405, July 1961.
- RAWLINSON, W. A., see TAYLOR, F. J. D., and others.
- RENGMAN, U., see FAUT, G. C. M., and others.
- REYNOLDS, F. H. The Potential Distribution and Thermionic Current between Parallel Plane Emitters. I.E.E. Monograph No. 408E, Mar. 1961 (*Proceedings I.E.E.*, Vol. 107B, p. 636, Nov. 1960).
- RISBERG, A., see FAUT, G. C. M., and others.
- ROBERTS, F. F., see TILLMAN, J. R.
- SHEARME, J. N., and HOLMES, J. N. An Experimental Study of the Classification of Sounds in Continuous Speech According to their Distribution in the Formant 1-Formant 2 Plane. Fourth International Congress on Phonetic Sciences, Helsinki, 1961.
- SHEARME, J. N., see SWAFFIELD, J., and others.
- SMITH, J. Sixty Years of Loading Coils. *Post Office Telecommunications Journal*, Vol. 13, p. 173, Autumn 1961.
- STANESBY, H. Recent Radio Communications Developments in the United Kingdom. Conference on New Developments in Electrical Traction and Telecommunications in Great Britain, Warsaw, 21-22 Mar. 1961 (Association of Polish Electrical Engineers (S.E.P.)).
- STRINGER, J. B. The Place of Character Recognition, Data Transmission and Document Handling in A.D.P. Systems. *The Computer Journal*, Vol. 4, p. 161, July 1961.
- STRINGER, J. B., see BENNETT, R. O.
- SWAFFIELD, J. Speech Quality Attainments with Synthetic Speech. Invited paper to the 1961 American Speech and Hearing Association Convention, Nov. 1961.
- SWAFFIELD, J., SHEARME, J. N., and HOLMES, J. N. Some Measurements on the Vowel Sounds of Conversational Speech. Invited paper to the Sixty-Second Meeting of the Acoustical Society of America, Nov. 1961.
- TAYLOR, F. J. D. U.R.S.I. Symposium on Space-Communication Research. *Journal I.E.E.*, Vol. 7, p. 664, Nov. 1961.
- TAYLOR, F. J. D., FLOYD, C. F., and RAWLINSON, S. A. Some Aspects of Measurement of Potentially Hazardous Electromagnetic Fields. Proceedings of the Third International Conference on Medical Electronics, London 1960, p. 393, 1961.
- TILLMAN, J. R., and ROBERTS, F. F. An Introduction to the Theory and Practice of Transistors (Sir Isaac Pitman & Sons, Ltd., London, 1961).
- WADDON, E. J. Interference Between Communications and Power Circuits. *Students' Quarterly Journal I.E.E.*, Vol. 31, p. 147, Mar. 1961.
- WATT-CARTER, D. E., and CORKE, R. L. Effect of External Conditions on the Phase of Radio Signals. *Nature*, Vol. 191, p. 1,286, 23 Sept. 1961.
- WILKINSON, R. G., see HAMER, R.

\* Messrs. Faut, Martony, Rengman, and Risberg are at the Royal Institute of Technology, Stockholm.

† Mr. Forshaw is with the Automatic Telephone & Electric Co., Ltd.

Post Office Staff are asked to send the Managing Editor details of their papers and articles published during 1962.

## BOARD OF EDITORS

D. A. BARRON, C.B.E., M.Sc., M.I.E.E., Chairman.  
L. F. SCANTLEBURY, Whit.Sch., A.C.G.I., D.I.C., M.I.E.E.  
T. H. FLOWERS, M.B.E., B.Sc.(Eng.), M.I.E.E.  
W. J. E. TOBIN, B.Sc.(Eng.), A.C.G.I., D.I.C., M.I.E.E.  
G. J. MILLEN, A.M.I.E.E.  
D. J. HARRIS, B.Sc.(Eng.), A.M.I.E.E.  
R. F. WALDEGRAVE.  
E. DAVIS, A.M.I.E.E., Managing Editor.  
A. G. LEIGHTON, B.Sc.(Eng.), A.M.I.E.E., Deputy Managing Editor.  
J. MARTIN, B.Sc.(Eng.), A.M.I.E.E. } Assistant Editors.  
R. A. SUDELL }  
B. FARR, A.B.I., Secretary-Treasurer.  
B. CROSS, Advertisement Manager.

### Copyright

The entire contents of this Journal are covered by general copyright, and special permission is necessary for reprinting long extracts, but editors are welcome to use not more than one-third of any article, provided that credit is given at the beginning or end thus: "From *The Post Office Electrical Engineers' Journal*."

The Board of Editors is not responsible for the statements made or the opinions expressed in any of the articles in this Journal, unless such statement is made specifically by the Board.

### Subscriptions and Back Numbers

The Journal is published quarterly, in April, July, October and January, price 2s. 6d. (3s. 6d. post paid) per copy or 14s. per year post paid (2 dollars 25 cents, Canada and U.S.A.). Back numbers will be supplied, if available, price 2s. 6d. (3s. 6d. post paid) per copy. Copies of the April 1959 and all earlier Journals are no longer available. Orders should be sent to *The Post Office*

*Electrical Engineers' Journal*, G.P.O., 2-12 Gresham Street, London, E.C.2.

Employees of the British Post Office can obtain the Journal through local agents.

### Binding

Readers can have their copies of volumes bound at a cost of 15s. by sending the complete set of parts to the local Post Office distribution agent or to *The Post Office Electrical Engineers' Journal*, G.P.O., 2-12 Gresham Street, London, E.C.2.

### Remittances

Remittances should be made payable to "*The P.O.E.E. Journal*" and should be crossed "& Co."

### Advertisements

All correspondence relating to advertisement space reservations, copy, proofs, etc., should be addressed to the Advertisement Manager, *The Post Office Electrical Engineers' Journal*, G.P.O., 2-12 Gresham Street, London, E.C.2.

### Communications

With the exceptions indicated above, all communications should be addressed to the Managing Editor, *The Post Office Electrical Engineers' Journal*, G.P.O., 2-12 Gresham Street, London, E.C.2. Telephone: HEADquarters 1234.

### Model Answer Books

Books of model answers to certain of the City and Guilds of London Institute examinations in telecommunications are published by the Board of Editors. Details of the books available are given at the end of the Supplement to the Journal.

*An Invitation*

phone BYWOOD 2321-2

VISIT OUR DISPLAY  
OF NEW EQUIPMENT



INFORMATION FROM

**DRALLIM INDUSTRIES LIMITED**

BOURNE WORKS, STATION APPROACH, WHYTELEAFE, SURREY

# TELEPHONE CABLES LIMITED

are especially pleased when they are called in at the earliest stages of a project—whether it be a country-wide telecommunications scheme, a complete sound or television network, or an exchange cable distribution scheme. Their advice will enable your requirements to be carried out speedily, efficiently, and at minimum cost without unnecessary interference to your existing system. TCL are specialists in the manufacture and installation of telephone cables and in the design of cable networks. In conjunction with their associated companies, TCL are able to design, manufacture and install a complete system for telecommunication projects anywhere in the world.

TELEPHONE CABLES LIMITED, DAGENHAM, ENGLAND • TELEPHONE DOMINION 6611 • CABLES DRYCORE DAGENHAM

call in  
TCL experience  
at the  
start

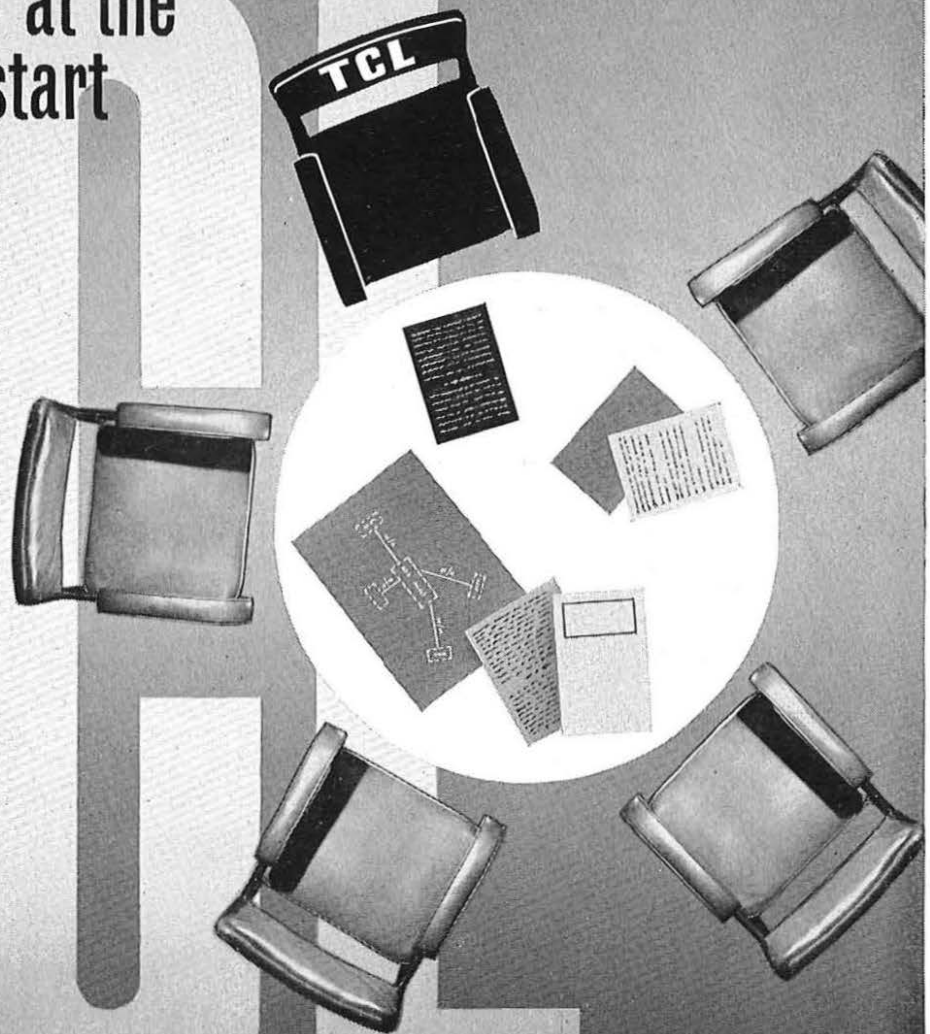

THE ORGANISATION WITH 125 YEARS' EXPERIENCE

The A.1426 provides a main outlet within the frequency range 3.0-6.999875 Mc/s in 125 c/s steps, locked to an external master frequency reference source at 100 kc/s.

- *Frequency adjustment from front panel or remotely*
- *Fully transistorized*
- *Provision for the addition of subsidiary fixed outlet frequencies to order, also locked to the master reference. If subsidiary outlets are not required, the master reference sources can be contained in the synthesizer*
- *Power unit incorporated, works from 240 V 50 c/s single phase supply (other voltages to order)*
- *Telescopic runners can be fitted for rack mounting*
- *Automatic alarm provided for indication of phase-lock failure*
- *All dividers consist of combinations of two-transistor binary circuits*
- *Weight only 31.25 lb (14.2 kg)*

# STC

## FREQUENCY SYNTHESIZER TYPE A.1426

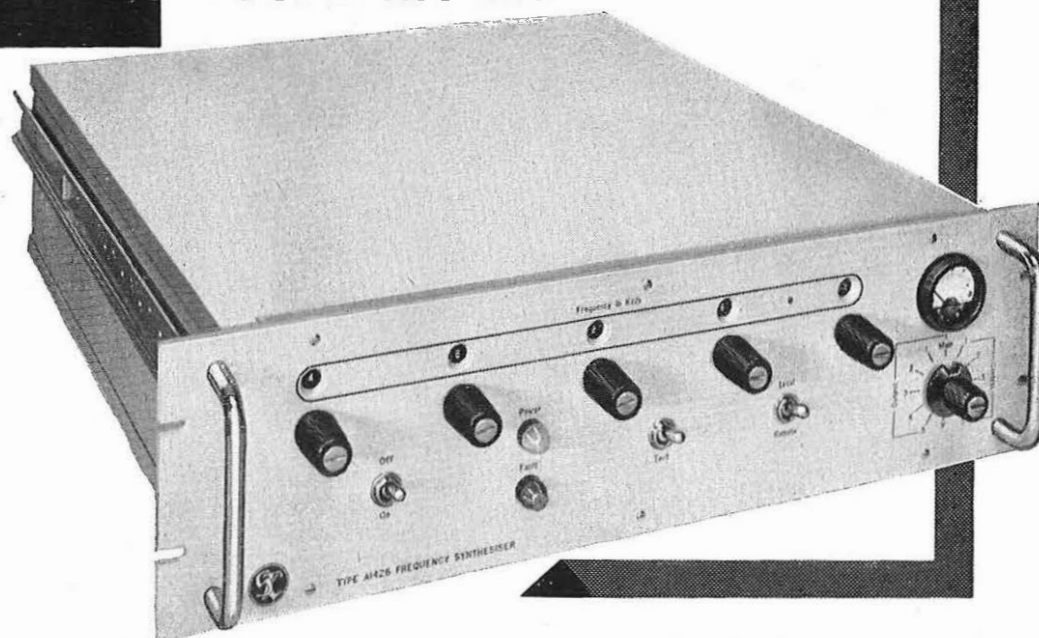

For further details ask for Radio Leaflet No. 306



61/12E

**Standard Telephones and Cables Limited**

RADIO DIVISION · OAKLEIGH ROAD · NEW SOUTHGATE · LONDON N.11

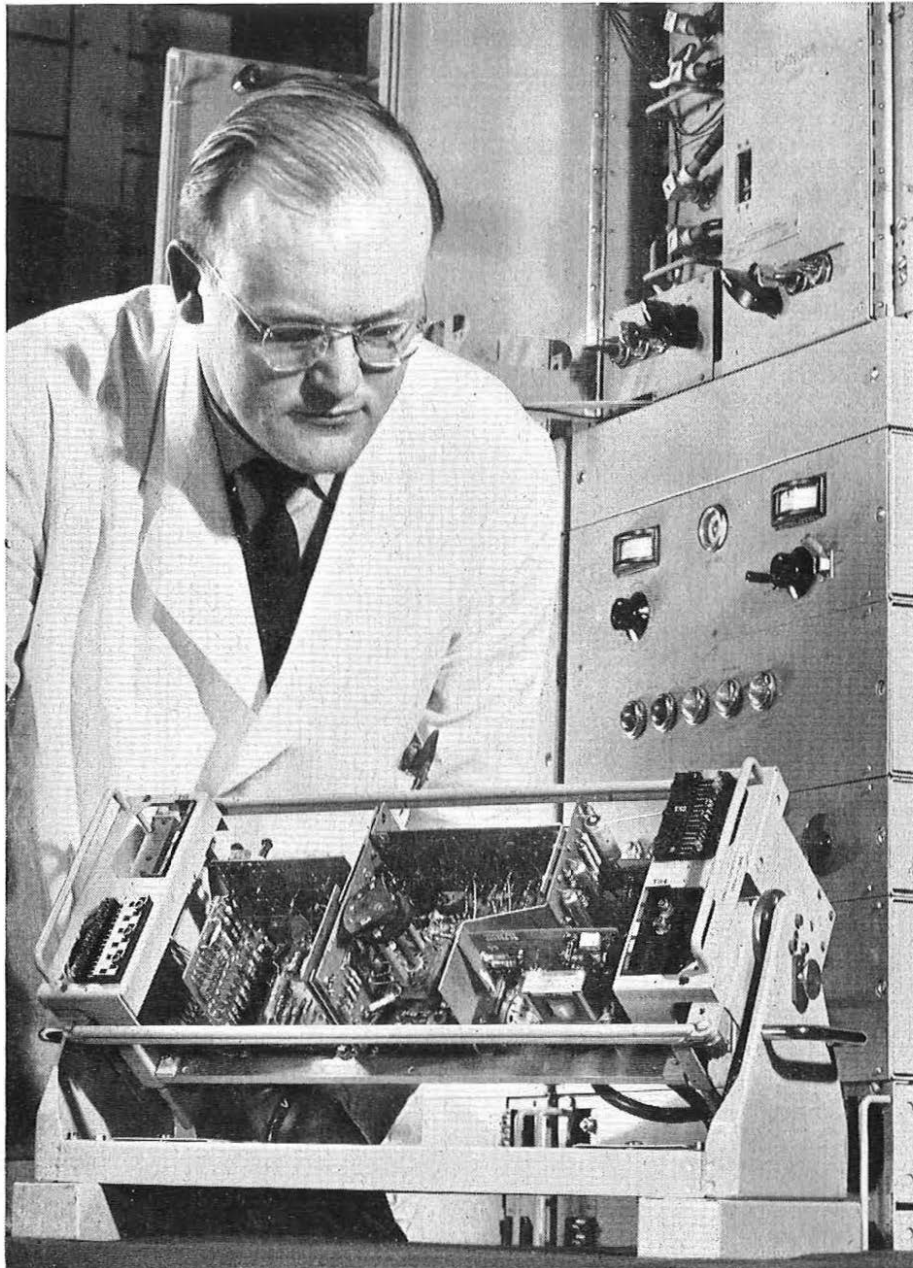

*An inspector makes a final visual examination of a 12 Mc/s coaxial amplifier before rack mounting.*

# PURSUIT OF PERFECTION

Tests—far more exacting than the strictest specification—mark every stage in the manufacture and assembly of A.T.E. transmission equipment.

Individual components—transistors, resistors, capacitors, transformers—are subject to the most searching scrutiny and test routines. This uncompromising

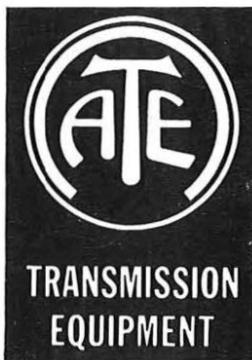

quality control continues progressively through sub-assemblies, on amplifiers, modulators and filters, right to the peak point of production.

These testing operations are carried out on a precision range of electronic test gear designed specially to conform to the essential conditional parameters.

**AUTOMATIC TELEPHONE & ELECTRIC CO. LTD., STROWGER HOUSE, ARUNDEL STREET, LONDON, W.C.2.**

Telephone: Temple Bar 9262. Telegrams: Strowger, Strand, London. STROWGER WORKS, LIVERPOOL 7.

# CANTAT

The new all-British cable from the British Isles to Newfoundland is equipped with 90 submerged telephone repeaters. All these were manufactured by

# STC



*Standard Telephones and Cables Limited*

TRANSMISSION SYSTEMS DIVISION · NORTH WOOLWICH · LONDON E.16



*terminating and monitoring  
cubicles and repeater power  
supplies for submarine cables*

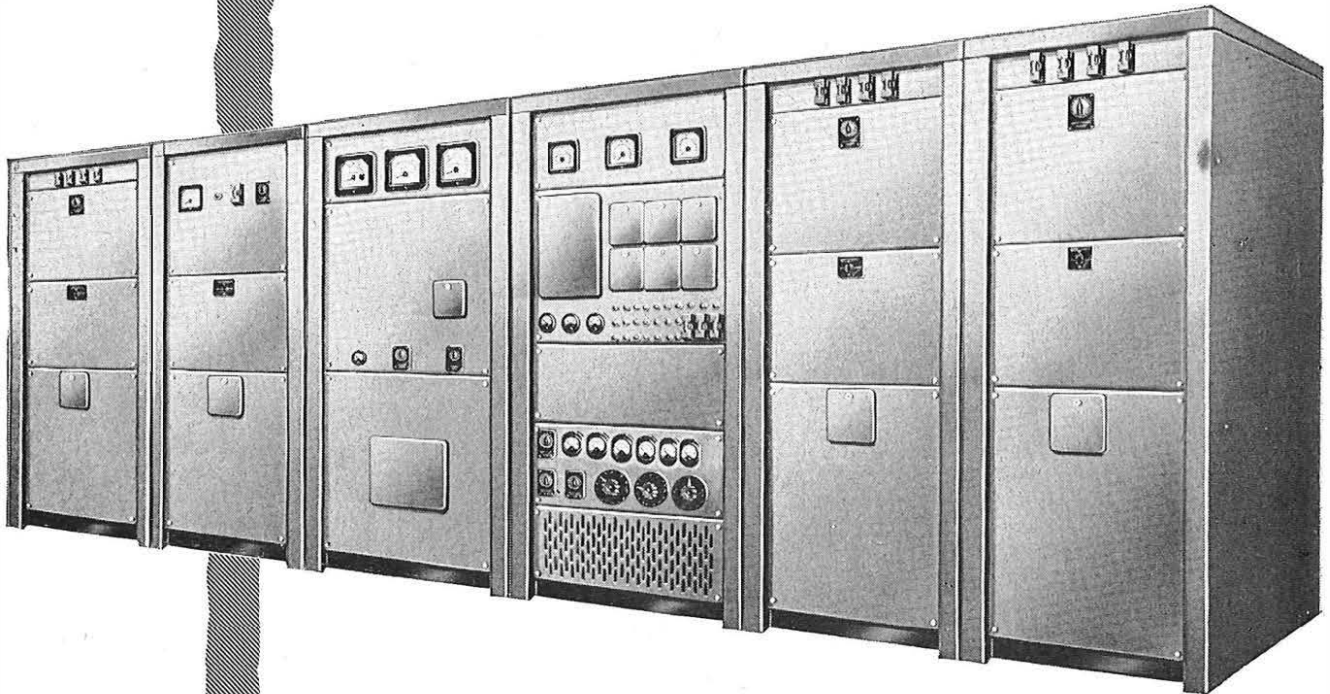

The repeaters are fed with constant current from one or both ends of a link. Extremely close limits of current stability are achieved under all combinations of load and wide fluctuations of input voltage and frequency. Owing to enormous distances between terminating stations, cable power input voltages up to 15kV are quite common.

Westinghouse have supplied cable power feed equipments for Anglo-Swedish, Bermuda-Manahawkin, and Oban-Cornerbrook submerged cables. In addition to these, similar equipments are being manufactured for the Commonwealth Pacific link incorporating Sydney, Auckland, Suva, Hawaii, Vancouver and Port Alberni. Special equipments of a similar kind have also been supplied for cable laying ships "Monarch" and "Alert" and a cable power feed equipment is now under construction for the Cable and Wireless Ship No. 1305.

*For further details write to Special Products, Rectifier Division, Dept. P.O. 4/62.*

**WESTINGHOUSE BRAKE AND SIGNAL CO. LTD**

**82 YORK WAY • KING'S CROSS • LONDON N.1. TER 6432**



# IF YOUR PROJECT JUSTIFIES THE DEVELOPMENT OF a new ELECTRON TUBE

We can help, because we have men and laboratories specializing in the development of electron tubes and they are backed by immense experience in the field of valve technology. From the STC Valve Development Laboratories have come the world's fastest cold cathode trigger tube, special travelling wave tubes, backward wave oscillators with frequencies up to 40 000 Mc/s, and wide-band amplifier valves with a gm of 47 mA/V. Recent STC developments include mesh structure, filament and grid in industrial triodes, with, for the first time in this country, optional ceramic envelopes. If you have to solve a problem concerning electron tubes, the technical resources of STC and one of the world's leading communications research laboratories are at your service.

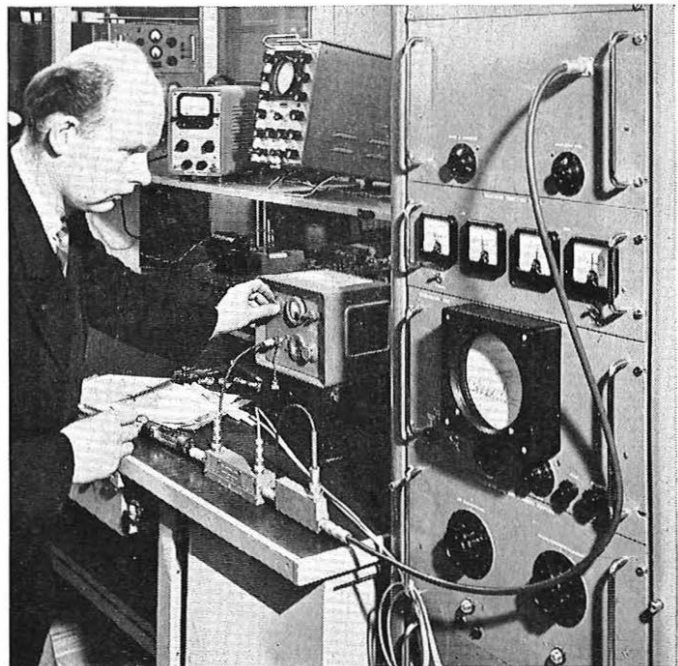

62/11MS

*Standard Telephones and Cables Limited*

VALVE DIVISION: BRIXHAM ROAD · PAIGNTON · DEVON  
LONDON SALES OFFICE: FOOTSCRAY · KENT · FOOTSCRAY 3333

# SPECIALISTS IN REPEATERED SUBMARINE TELEPHONE CABLE SYSTEMS

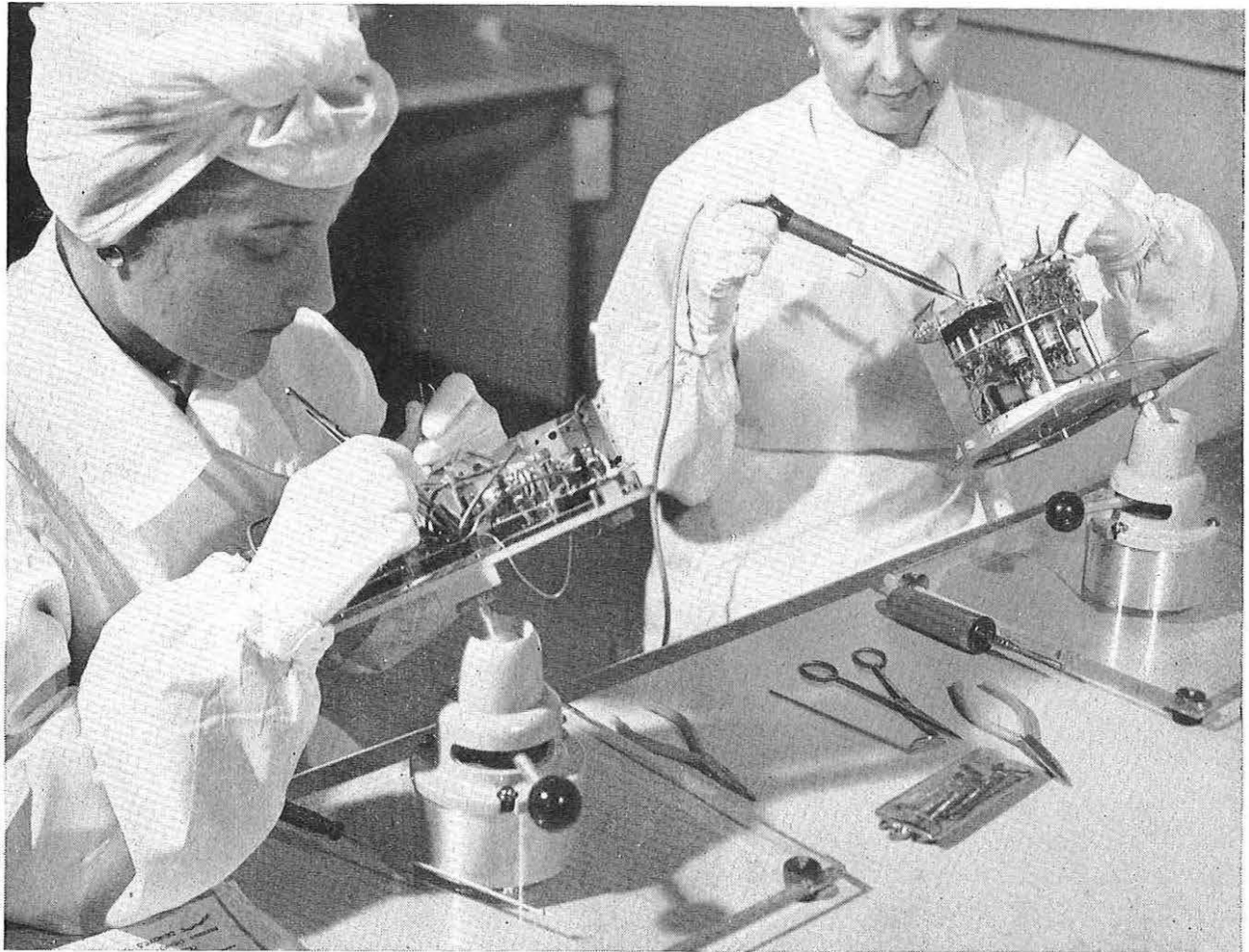

*Wiring and assembly of units for Submerged Repeater*

Submarine Cables Ltd., specialise in complete submarine telephone cable systems—cable, submerged repeaters, cable laying and terminal equipment.

Submarine Cables Ltd. developed the new unarmoured (lightweight) cable designed by the British Post Office and the Company's factory at Greenwich has supplied this type of cable for the first Commonwealth link (called CANTAT) between Scotland and Canada, to the order of the Canadian Overseas Telecommunication Corporation and Cable and Wireless Ltd. Their Repeater Division at Erith, Kent, has made the submerged repeaters for the CANTAT extension from Newfoundland up the St. Lawrence River, to the order of the Canadian Overseas Telecommunication Corporation.

Submarine Cables Ltd., backed by over a hundred years of experience, are in a position to give expert technical advice on any submarine-cable telecommunications problem.

## SUBMARINE CABLES LIMITED

*Owned jointly by Associated Electrical Industries Ltd. and British Insulated Callender's Cables Ltd.*

HEAD OFFICE: Mercury House, Theobald's Road, London WC1 · Telephone: HOLborn 8711 · Telegrams: Telsiem, London, Westcent. · Cablegrams: Talsiem London WC1 WORKS: Telcon Works, Greenwich: Ocean Works, Erith, Kent.

testing  
communications systems  
which serve  
the world.....

To install and maintain all telecommunications systems — Audio, Broadcast, Telegraph, Multi-channel, Coaxial, Submarine Cable and Microwave, etc. — STC provides a wide range of transmission testing apparatus.

As actual manufacturers of a great variety of telecommunications equipment, including the constituent components, STC have an unrivalled knowledge of data, performance, life and factors to be tested to keep the equipment in peak condition.

That knowledge is embodied in all STC testing apparatus together with all the precision and reliability for which STC equipment is world-famous.



OSCILLATORS · LEVEL MEASURING SETS · MICROWAVE TEST SETS  
BRIDGES · FILTERS · PSOPHOMETERS · WHITE NOISE TEST SETS, ETC.



62/2CTA

Send for leaflets covering your systems:

**Standard Telephones and Cables Limited**

TRANSMISSION SYSTEMS GROUP: NORTH WOOLWICH · LONDON · E.16

# A NEW WALL TELEPHONE THE "G.E.C. 711"



By employing the same components as the 'New Gecophone' (the GEC 706 Telephone), this new wall telephone has the same high standard of performance with the added advantage that Administrations need only stock the same component spare parts for both the table and wall telephones.

The bases of the two telephones are the same, thus enabling a GEC plinth to convert the wall instruments to a plan-type telephone.

The telephone is being supplied for use by the British Post Office as their standard wall instrument.

**G.E.C.**

**TELEPHONES FOR ALL PURPOSES**

TELEPHONE DIVISION

**G.E.C. (TELECOMMUNICATIONS) LTD**

Telephone Works · Coventry · England

Works at Coventry and Middlesbrough

# STC

## telecommunication cables



Contractors to the  
British Post Office  
British Railways  
British Commonwealth  
Government Depts.  
And numerous Home and  
Overseas administrations

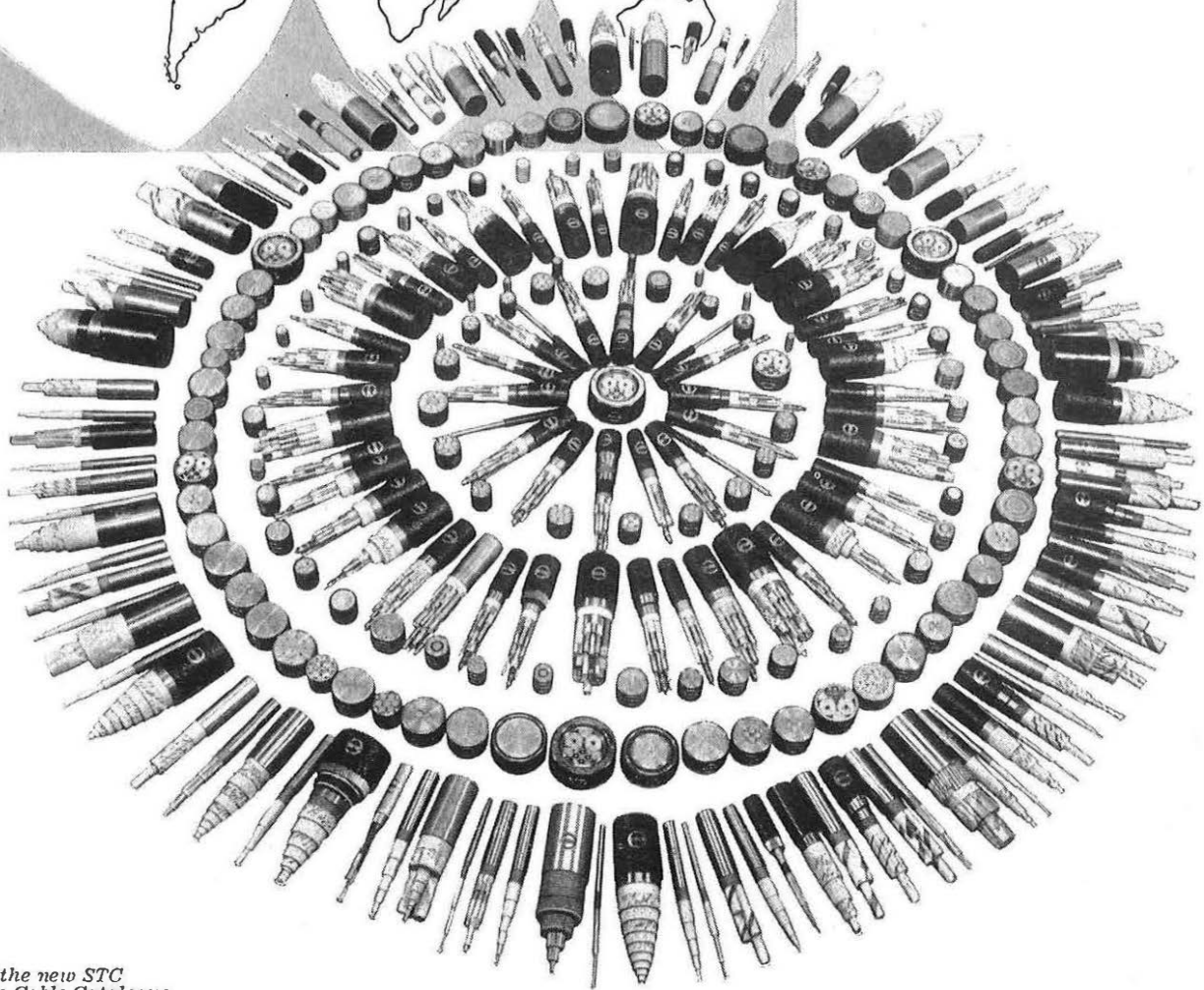

Write for the new STC  
Telephone Cable Catalogue  
B1102

STC DEVELOP, MANUFACTURE, AND INSTALL ALL TYPES OF TELECOMMUNICATION CABLES



61/5B

**Standard Telephones and Cables Limited**

TELEPHONE CABLE DIVISION: NORTH WOOLWICH · LONDON E.16

# ADCOLA

REGISTERED TRADE MARK  
(Regd. Trade Mark)

## SOLDERING INSTRUMENTS and EQUIPMENT

Illustrated  
L64  $\frac{3}{8}$ " DETACHABLE  
BIT MODEL IN  
PROTECTIVE  
SHIELD L700  
FITTED WITH  
ACCESSORIES FOR  
BIT CLEANING, ETC.

ALL VOLT RANGES  
6/7 to 230/250 VOLTS

British and Foreign  
Patents and Registered  
designs

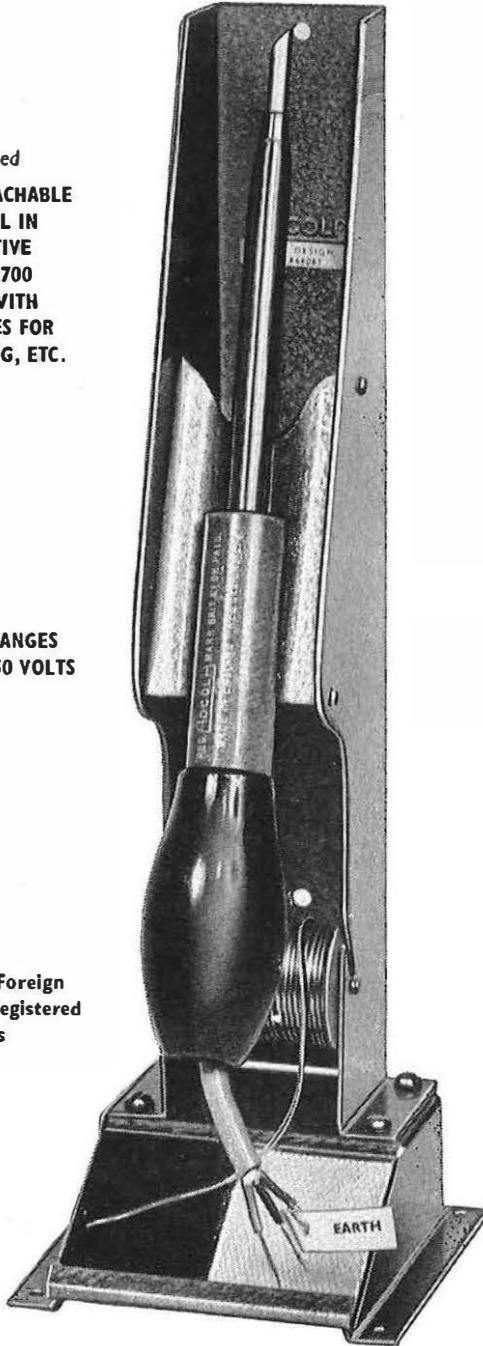

For further information and full illustrated catalogue apply head office

**ADCOLA PRODUCTS LIMITED**  
ADCOLA HOUSE, GAUDEN ROAD,  
LONDON, S.W.4

Telephones:  
MACaulay 3101 and 4272

Telegrams:  
SOLJOINT, LONDON, S.W.4

# GPO choose OXLEY air-trimmer for Type N Submerged Repeater on Trans-Atlantic and Trans- Pacific Telephone Cables

The economics of present-day long-distance submarine cable schemes require an average repeater life of more than 20 years. G.P.O. Engineers have devoted considerable skill and research into creating a repeater that measures up to the exacting conditions with economy.

B END SUPPORTED  
BY CORONET

B POWER FILTER

SUPERVISORY  
AB UNIT

SUPERVISORY  
C UNIT

A BRIDGE AND  
HF EQUALISER

NOISE STOP FILTER

DIRECTIONAL FILTERS

PROTECTOR UNIT

AMPLIFIER

VALVE HEATER  
SHUNTS

DIRECTIONAL FILTERS

B BRIDGE AND  
LF EQUALISER

A POWER FILTER

A END  
MOUNTED  
ON BULKHEAD

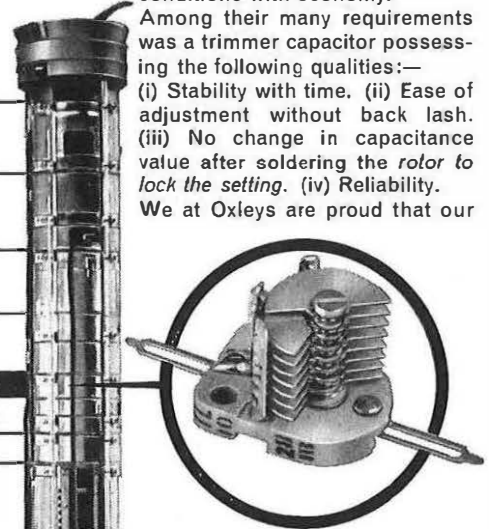

Among their many requirements was a trimmer capacitor possessing the following qualities:—

- (i) Stability with time.
- (ii) Ease of adjustment without back lash.
- (iii) No change in capacitance value after soldering the rotor to lock the setting.
- (iv) Reliability.

We at Oxleys are proud that our

trimmer capacitors have been chosen for this arduous task. The trimmers are used in noise stop filters in submerged repeaters, and in submerged equalisers. To meet the conditions, the spacings between the stator and rotor plates were increased approximately 3 times above normal spacing. All metal parts, except the beryllium-copper torque adjustment washers, are gold plated. The final design has a capacitance range of 2.5—18.0pF. The capacitance changes after temperature cycling in the range  $-10^{\circ}$  to  $+70^{\circ}$  C, and vibration testing in the range 30—130 c/s are less than 0.1pF.

The capacitors are tested at 1,000V d.c., and the insulation resistance, after 1 min. at 300V d.c., is greater than 1,000,000 megohms.

For full technical information for these and other Oxley products, write to

# OXLEY

DEVELOPMENTS COMPANY LTD.  
ULVERSTON, LANCASHIRE

Telephone: Ulverston 3306 Cables: Oxley, Ulverston

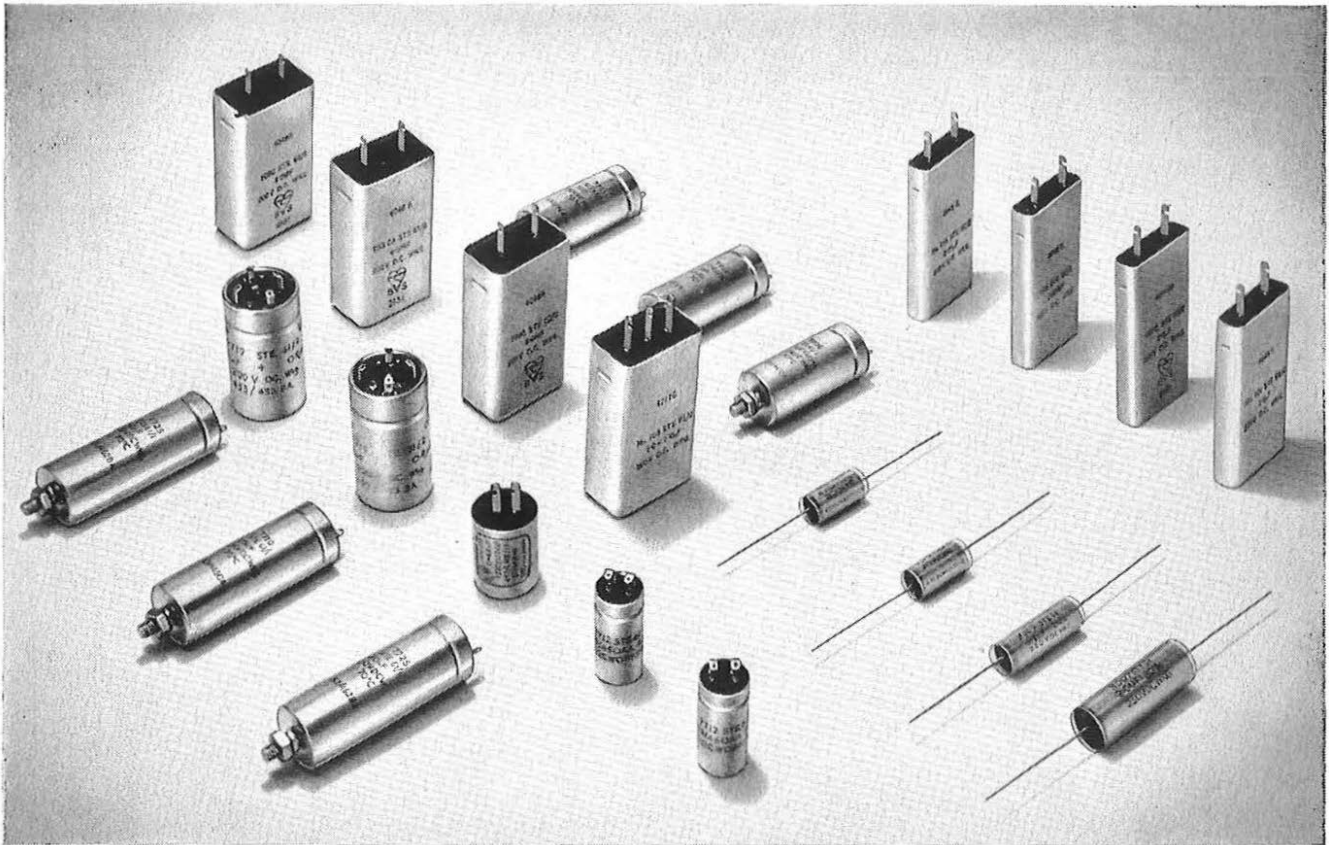

# STC BRITISH POST OFFICE TYPE CAPACITORS

STC also manufacture the following miniature capacitors suitable for use in transistorized switching circuits:

**Sintered-anode, solid electrolyte Tantalum**

**Foil-type, wet electrolyte Tantalum Coated foil (Stantelac)**

**Mica  
Polystyrene**

B.P.O. Number	STC Code	B.P.O. Number	STC Code
94	453/LWA/6B	7710	453/LWA/465CA
100	4049	7710 Pair	453/LWA/465PA
101	4049Y	7711	453/LWA/461DA
102	4048	7712	453/LWA/450AA
102C	4049BA	7718	453/LWA/460CA
102CA	4049BB	7719 Mk 2	453/LWA/453BA
103C	4048R	7720	453/LWA/1A
103CA	4048P	7721	453/LWA/464AA
104	4049H	7723	453/LWA/464BA
105	4711C	7724	453/LWA/463AA
106	4049V	7725	453/LWA/462BA
115	4049B	7727	453/LWA/466DA
119	4049C	8001	455/LWA/432CA
150	4061B	8003	455/LWA/430CA
151	4061F	8004	455/LWA/431CA
152	4062	8005	455/LWA/433CA
7708	453/LWA/461CA	8006	455/LWA/434CA
7708 Pair	453/LWA/461PA	8007	455/LWA/435CA
7709	453/LWA/461CB		



62/5MC

*Standard Telephones and Cables Limited*

COMPONENTS GROUP

CAPACITOR DIVISION: BRIXHAM ROAD · PAIGNTON · DEVON

# G.E.C. SHF MALAYAN MICROWAVE

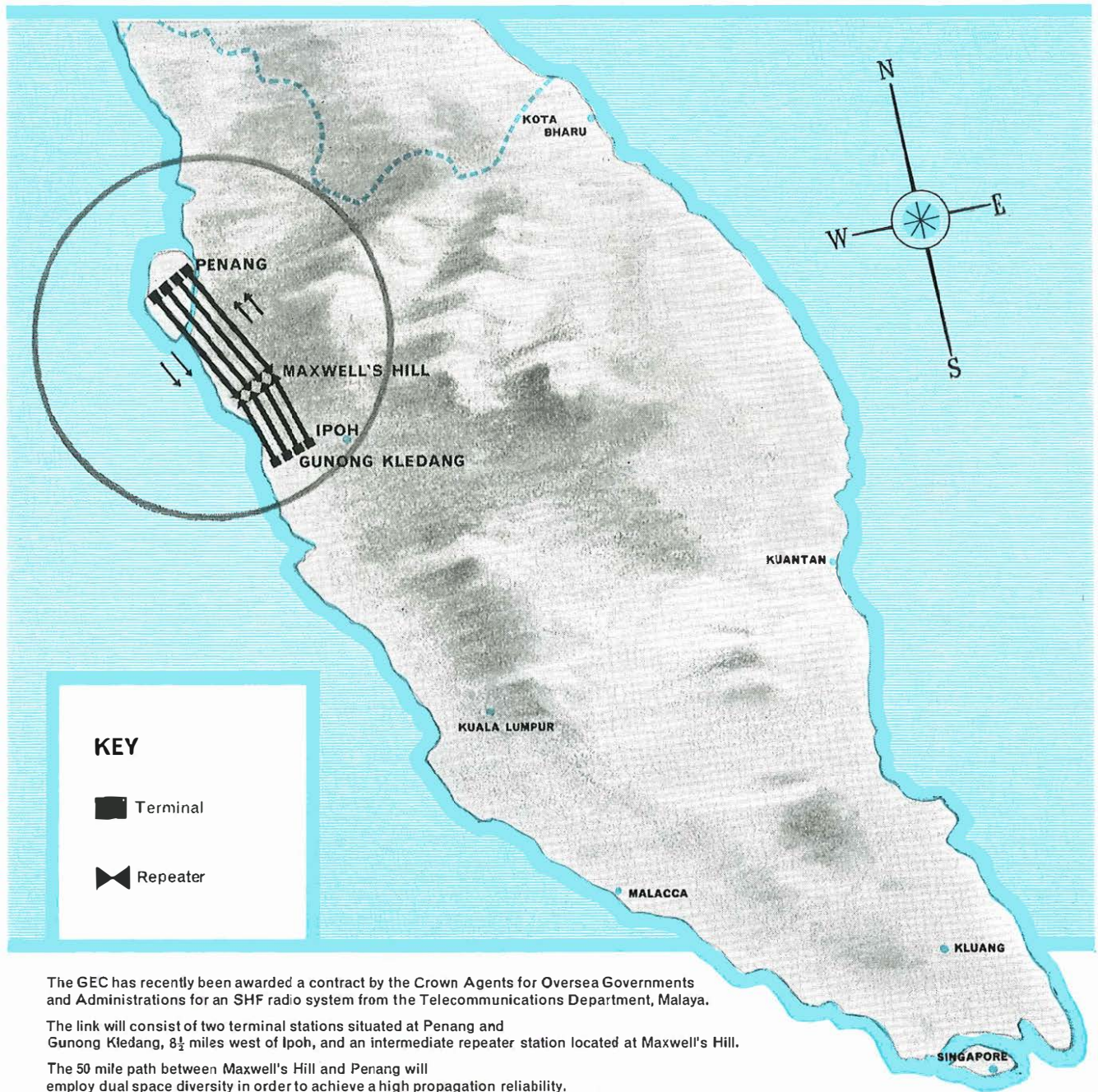

## KEY

■ Terminal

◀▶ Repeater

The GEC has recently been awarded a contract by the Crown Agents for Oversea Governments and Administrations for an SHF radio system from the Telecommunications Department, Malaya.

The link will consist of two terminal stations situated at Penang and Gunong Kledang, 8½ miles west of Ipoh, and an intermediate repeater station located at Maxwell's Hill.

The 50 mile path between Maxwell's Hill and Penang will employ dual space diversity in order to achieve a high propagation reliability.

The system will initially be equipped with a main and a protection radio channel in each direction of transmission with automatic switching in the event of failure of the working radio channel. The switching equipment will be arranged so that in the future, additional RF channels can be added and these will utilise the one protection channel initially provided.

In addition to the broadband radio equipment, the route will be equipped with an auxiliary SHF link for conveying engineer's speaker circuits and remote controls and alarms. This narrow band SHF channel is multiplexed together with the main channels for connection to the same paraboloid antenna.

The consultants for this contract are Messrs. Preece, Cardew and Rider.

**EVERYTHING FOR TELECOMMUNICATIONS**

**G.E.C.**

For further information  
please write for Standard Specification SPO 5555

Transmission Division

G.E.C. (TELECOMMUNICATIONS) LTD · Telephone Works · Coventry · England  
Works at Coventry and Middlesbrough



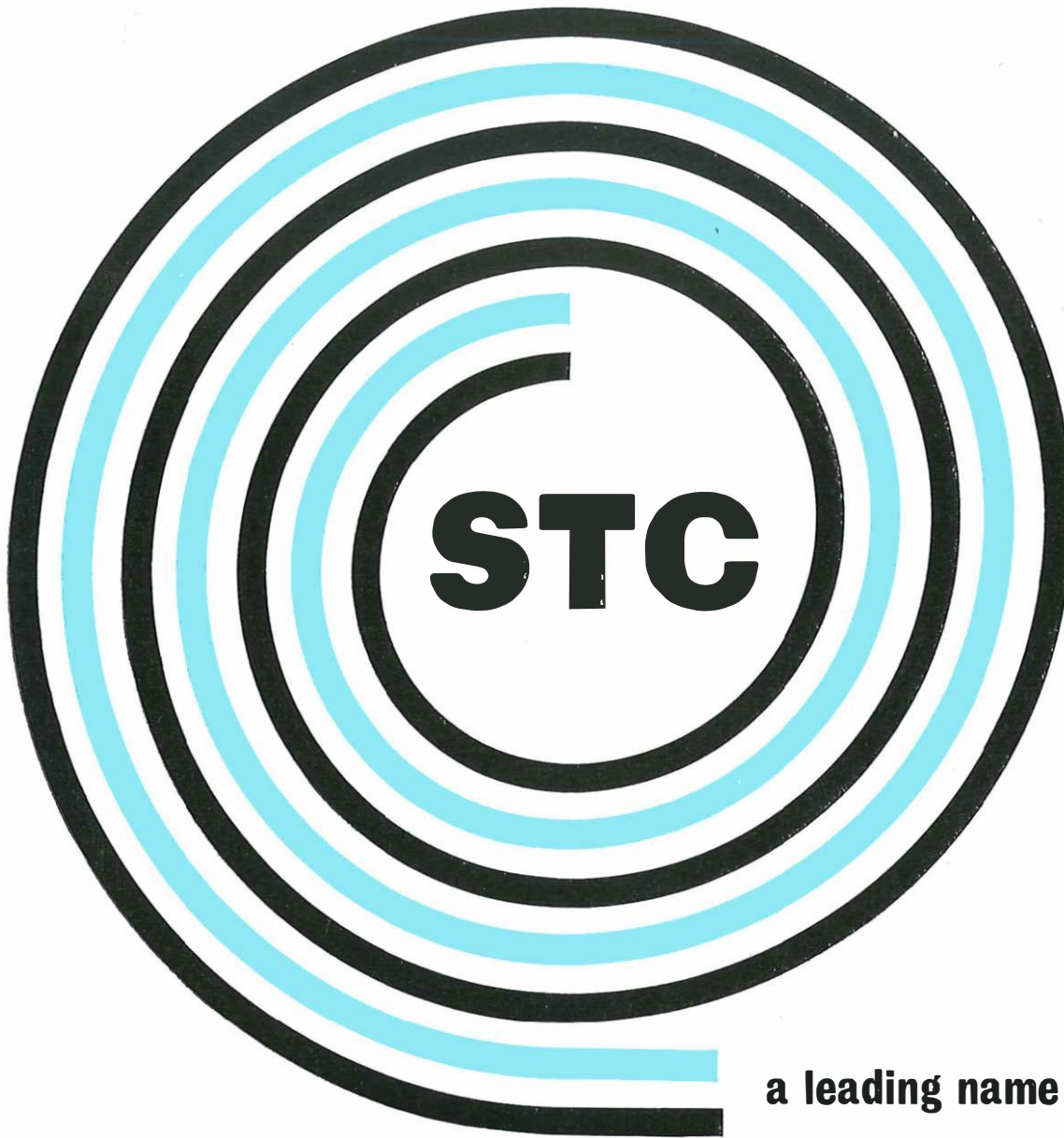

## a leading name in cables

STC manufacture plastic insulated telecommunication cables and wires in a very wide variety of types and sizes—from unit twin distribution cable (BPO Spec. 171), overall diameter  $2\frac{3}{4}$  in. containing 2000 pairs, to subminiature h.f. coaxial cable, 75 ohms, overall diameter 0.064 in.

*Write for STC publications covering telecommunications cables.*



***Standard Telephones and Cables Limited***

RUBBER & PLASTIC CABLE DIVISION: CORPORATION ROAD • NEWPORT • MON.

# S.E.C.

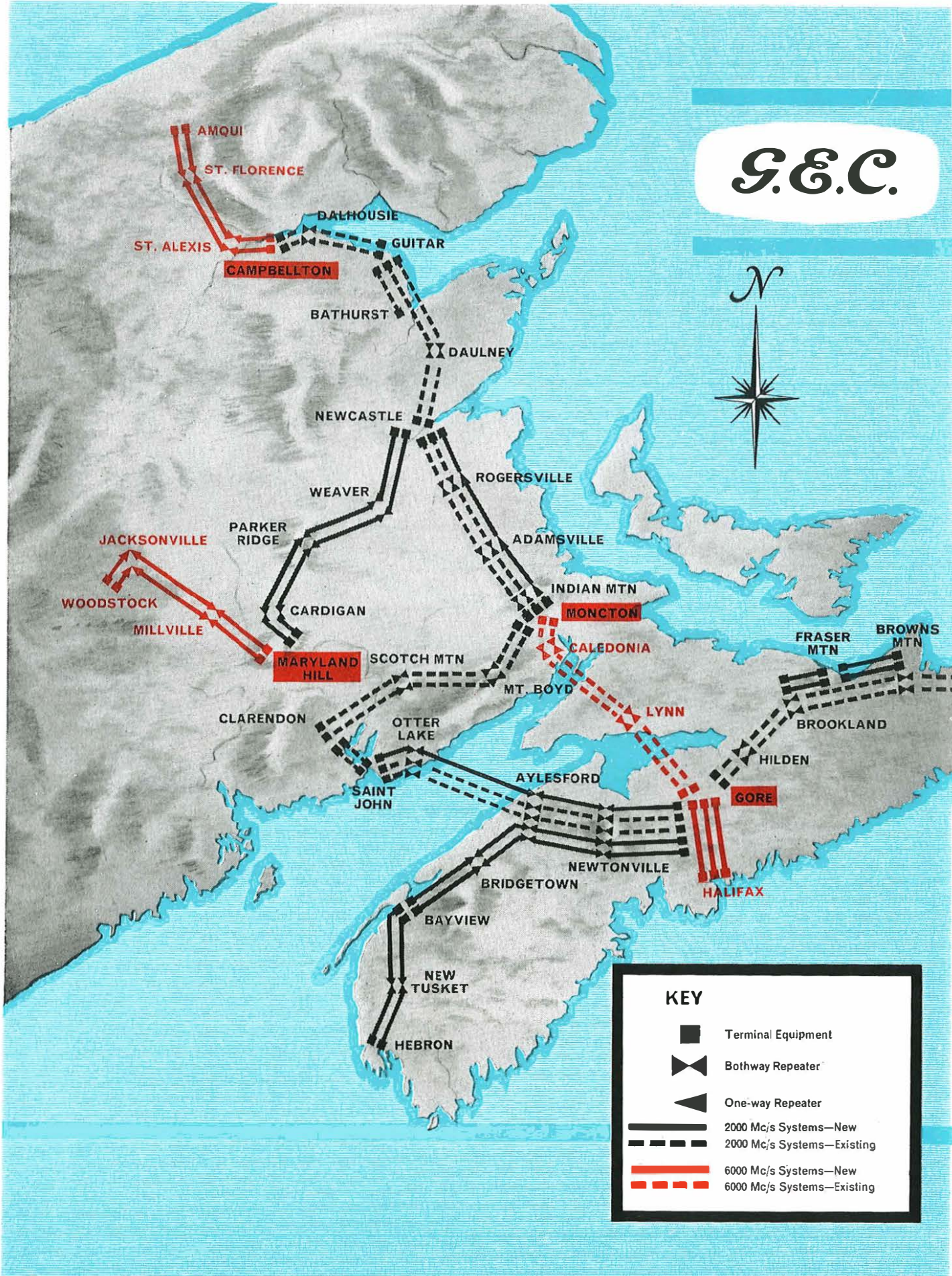

**KEY**

- Terminal Equipment
- ⌘ Bothway Repeater
- ▲ One-way Repeater
- 2000 Mc/s Systems—New
- - - 2000 Mc/s Systems—Existing
- 6000 Mc/s Systems—New
- - - 6000 Mc/s Systems—Existing

# FURTHER ADDITIONS TO THE MICROWAVE COMPLEX IN EASTERN CANADA



Expansion of the networks operated by The New Brunswick Telephone Company, the Maritime Telegraph and Telephone Company and the Quebec Telephone Company has resulted in further large orders for both UHF and SHF radio relay and the associated voice multiplex equipments.

The extensions now on order will provide the network with additional 360 television channel/miles and 230,000 speech circuit/miles.

The radio and multiplexing equipments used will be manufactured by GEC (Telecommunications) Ltd and supplied and installed by Canadian General Electric Company.

The new extensions will employ customer proven GEC microwave equipments operating in the 2000 Mc/s and 6000 Mc/s frequency bands, and transistored multiplex equipment.

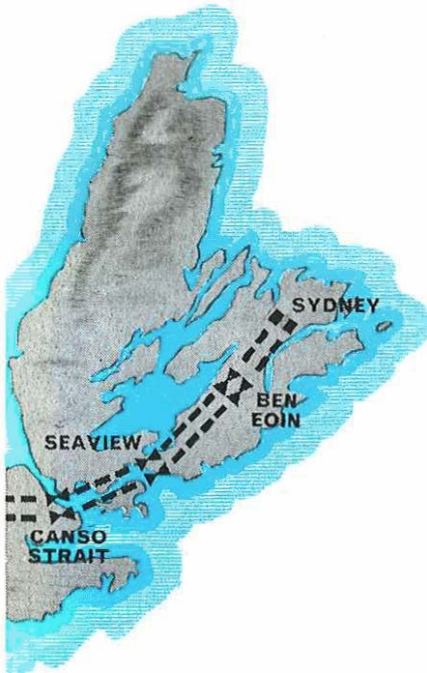

**EVERYTHING FOR  
TELECOMMUNICATIONS**

TRANSMISSION DIVISION

**GEC (TELECOMMUNICATIONS) LTD**

TELEPHONE WORKS · COVENTRY · ENGLAND *Works at Coventry and Middlesbrough*

*For further information on the radio and multiplexing equipments please write for Standard Specifications SPO 5555, SPO 5502 and SPO 1372*

# FIJI chooses G.E.C. UHF radio equipment

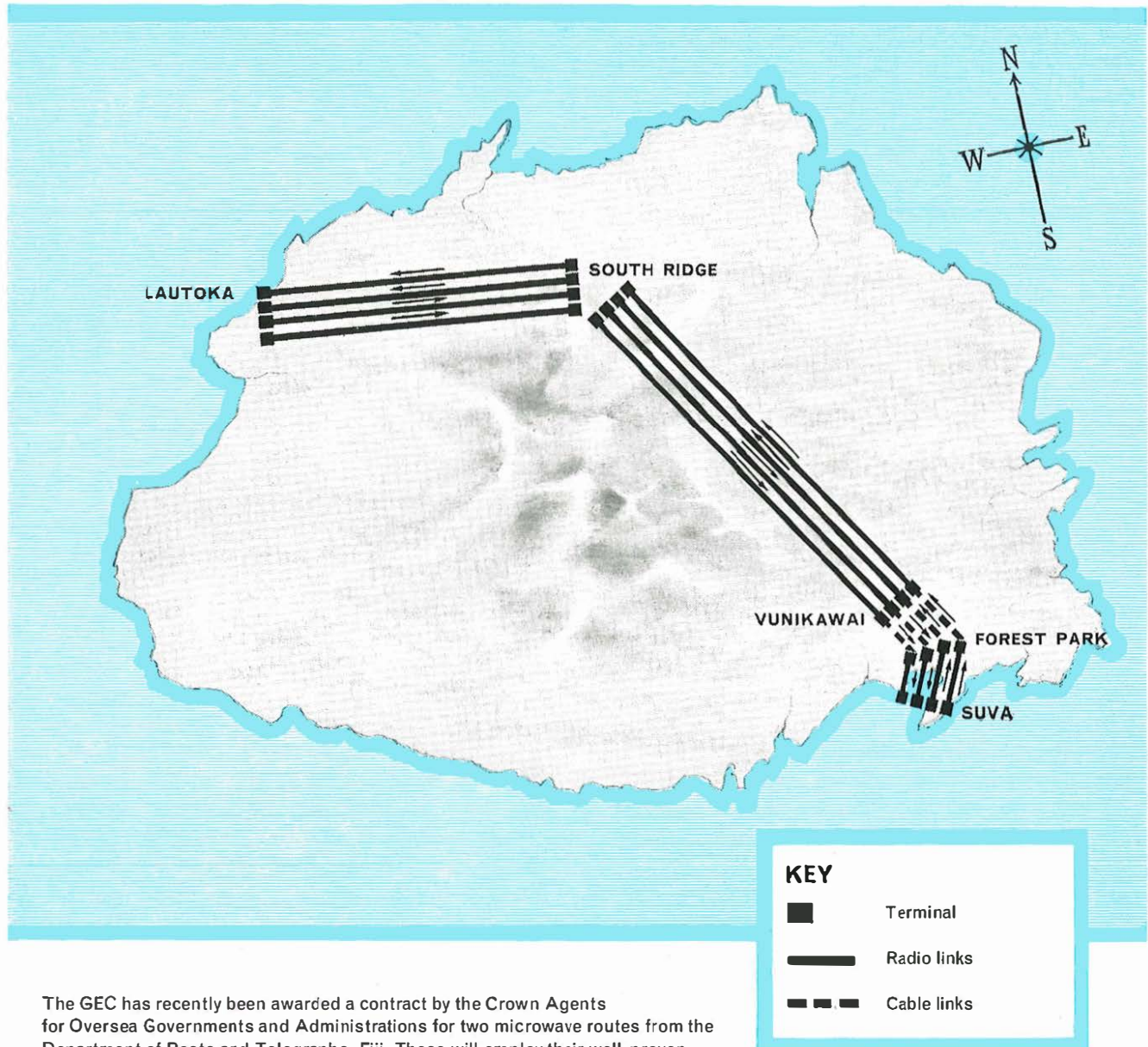

The GEC has recently been awarded a contract by the Crown Agents for Oversea Governments and Administrations for two microwave routes from the Department of Posts and Telegraphs, Fiji. These will employ their well-proven 2000 Mc/s broadband radio equipment having a capacity of 300 speech circuits.

Both routes will be equipped with a main and a protection channel and in the event of failure or degradation of the working radio channel, changeover to the protection channel is automatic.

One route links South Ridge and Lautoka whilst the second route links Suva and South Ridge.

This latter route has an intermediate baseband repeater which is split. One half of the repeater is situated at Forest Park providing a line of sight path to Suva and the other half of the repeater is located at Vunikawai providing a line of sight path to South Ridge. The equipments at Forest Park and Vunikawai are interconnected at baseband frequency via 2½ miles of coaxial cable.

The consultants for this contract are Messrs. Preece, Cardew & Rider.

**EVERYTHING FOR TELECOMMUNICATIONS**

**G.E.C.**

For further information  
please write for Standard Specification SPO 5502.

Transmission Division  
G.E.C. (TELECOMMUNICATIONS) LTD · Telephone Works · Coventry · England  
Works at Coventry and Middlesbrough

ETELUX  
ETELUX  
ETELUX  
ETELUX  
ETELUX  
ETELUX

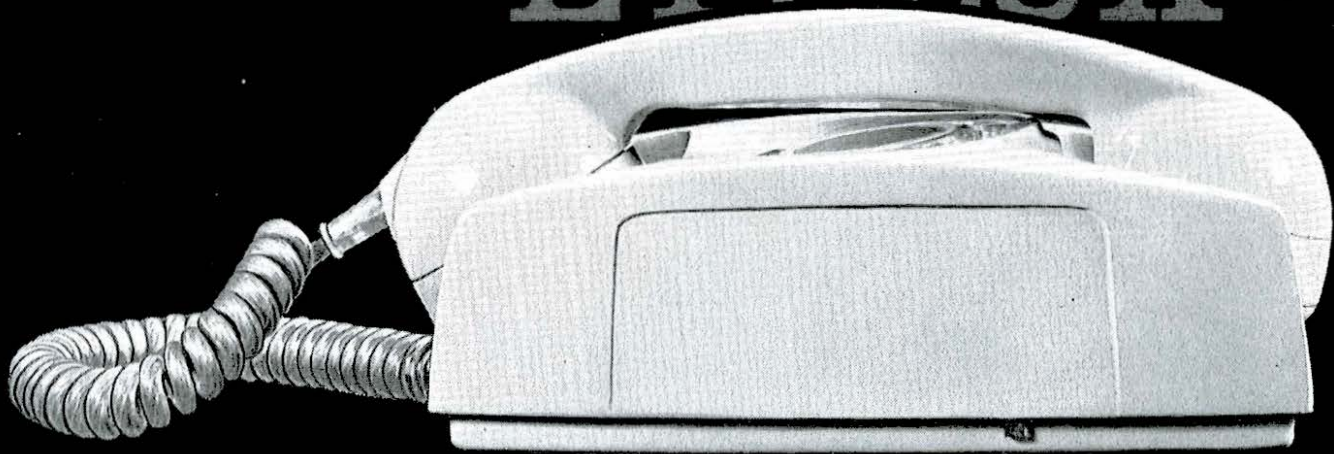

ETELUX  
ETELUX

## THE NEW LUXURY TELEPHONE



Manufactured exclusively by Ericsson, the Etelux is a refreshingly new concept of telephone instrument design. A great deal of thought has been devoted to the ergonomic and aesthetic problems involved in the evolution of an instrument of this nature, and among its many outstanding features is its distinctive appearance and ease with which it can be handled. It is easily convertible to wall mounting for use in kitchen, hall or any location where table space is restricted. Dial illumination, and press-button for "operator re-call" or party line working, can be provided as an optional extra. The Etelux is offered in a range of colours which have been chosen for compatibility with a wide variety of interior decor, and these are:—

Aqua Jade, Alice Blue, Dusky Pink, Rose Grey and Blush Ivory. The base is Kashmir Beige, dial Silver Gilt and H.M.T. Cord Bronze Lustre.

This instrument has a technical performance equal to that of the Etelphone and can be supplied in full tropical finish.



ERICSSON TELEPHONES LIMITED • ETELCO LIMITED

**G.E.C.**

**THE  
COMPLETE  
TELE-  
COMMUNICATIONS  
SERVICE**

**RESEARCH**

**DEVELOPMENT**

**DESIGN**

**MANUFACTURE**

**SURVEY**

**PLANNING**

**INSTALLATION**

**MAINTENANCE**

*Transmission Division*

**G.E.C. (TELECOMMUNICATIONS) LTD**

**TELEPHONE WORKS · COVENTRY · ENGLAND**

*Works at Coventry and Middlesbrough*

SPOTLIGHT  
No. 3

## SURVEY and PLANNING

The GEC as manufacturers of a comprehensive range of transmission equipments for line, cable and radio links are able to survey and plan complete telecommunication networks without bias towards one particular medium.

Administrations know from experience that they can rely on GEC to recommend systems that are best suited to the requirements of the particular territory after careful study of the rate and areas of development, climatic and topographic features and the grade of maintenance available, not forgetting the economic utilisation of existing plant.

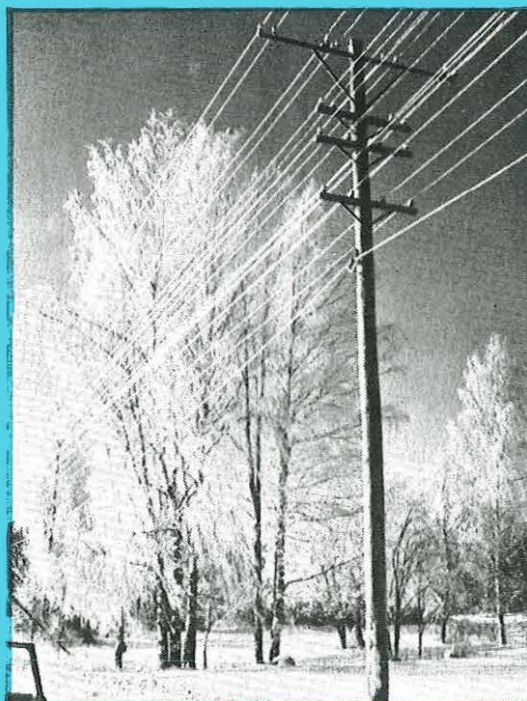

Line survey in Northern Europe.



Microwave path testing in the Middle East.

**S.E.C.**

**EVERYTHING FOR TELECOMMUNICATIONS**

★ **AMP** -BLADE  
**CONNECTORS**  
 FOR  
 PRINTED  
 CIRCUITS

These new connectors bring the benefits of AMP termination to printed circuit techniques, ensuring maximum reliability and trouble-free performances at lower installed costs. Being rigidly fixed to the printed circuit board, the tab housing acts as reinforcement, preventing distortion and consequent damage, even with frequent engagement and disconnection. The detachable contact housing carries the exact number of contacts required—no more, no less! AMP-Blade Connectors are suitable for use on ( $\frac{1}{16}$ "), ( $\frac{3}{32}$ " and  $\frac{1}{8}$ " ) printed boards, in a range of six sizes.

**ANOTHER AMP-FIRST**

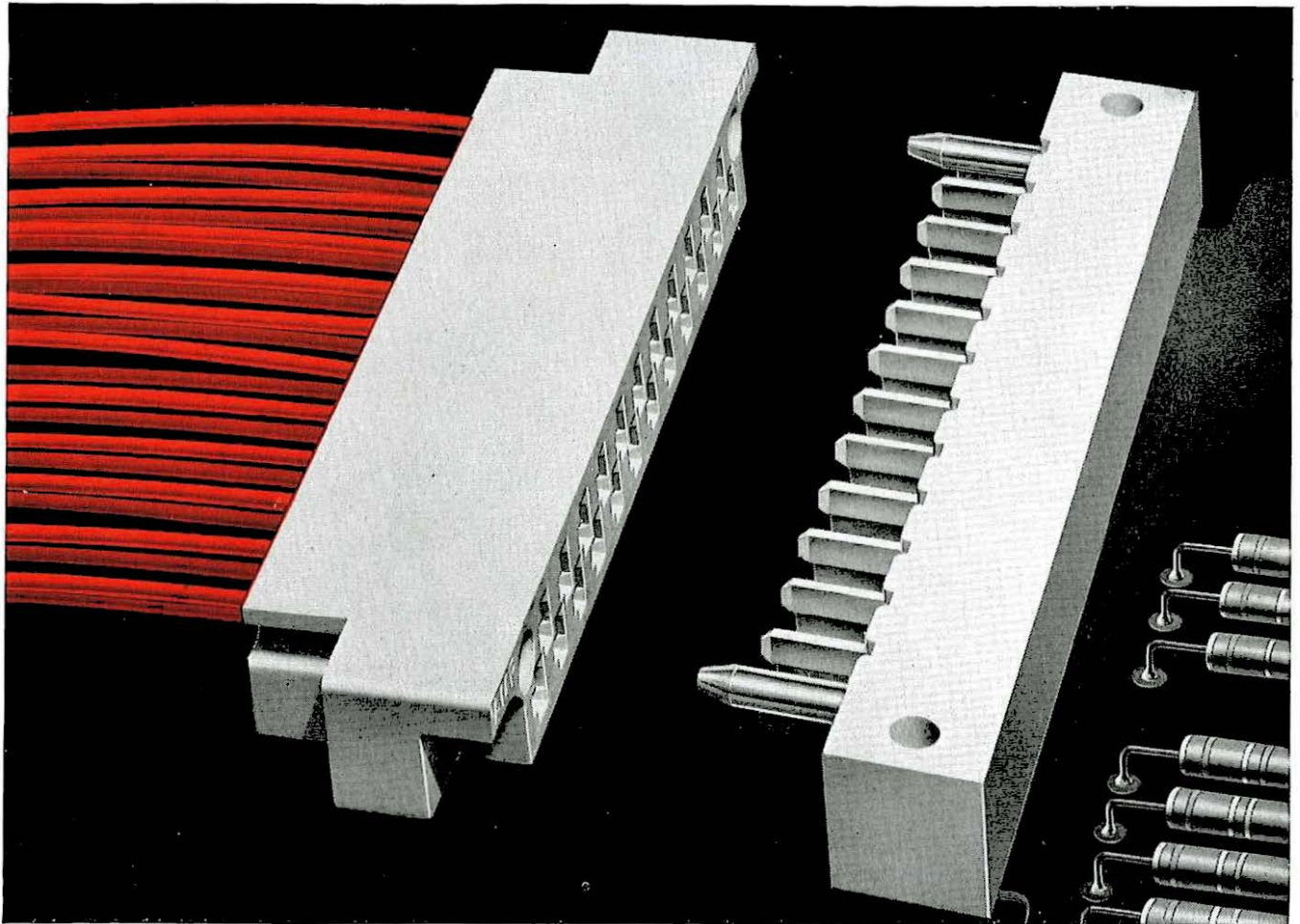

- No paid-for but unused contacts
- No risk of moisture entrapment
- Rigid guide pins ensure perfect mating
- Removable snap-in crimped contact on every lead
- Recessed cavities for leads eliminate sleeving of contacts
- Exact alignment of socket and blade at all times
- Available with 17, 23, 29, 35, 41 or 47 contacts
- Large contact area reduces wear, increases life
- Blocks can be keyed using plugs or moulded bosses
- Consistent pressures with any number of contacts
- Contacts can only be inserted and pushed home one way
- Termination by A-MP precision controlled crimp technique using automatic machine or hand tool



★ Trade mark of  
 AMP Incorporated U.S.A.

**AIRCRAFT-MARINE PRODUCTS (GT. BRITAIN) LTD**

Head Office: AMPLO HOUSE, 87/89 SAFFRON HILL, LONDON, E.C.1.

Tel: CHAncery 2902 (7 lines) Telex: 23513 Cables: AMPLO LONDON TELEX

SOUTH AFRICA DISTRIBUTOR: E. S. MOWAT & SONS (PTY) LTD. 51-57, MILNE STREET, P.O. BOX 437 DURBAN, NATAL  
 ASSOCIATED COMPANIES IN U.S.A., AUSTRALIA, CANADA, HOLLAND, FRANCE, GERMANY, ITALY, JAPAN, AND MEXICO



Exterior view of the 400 amp type **HH** 3-phase switch unit incorporated in a distribution switchboard installation at the Chapel-en-le-Frith Works, Stockport, of Ferodo Ltd.

Below:—

Interior view of a switch unit made by A. Reyrolle & Co. Ltd., Hebburn, County Durham. The arc chutes are moulded from 'Diakon' acrylic polymer by Thermo Plastics Ltd., Luton Rd., Dunstable, Bedfordshire.

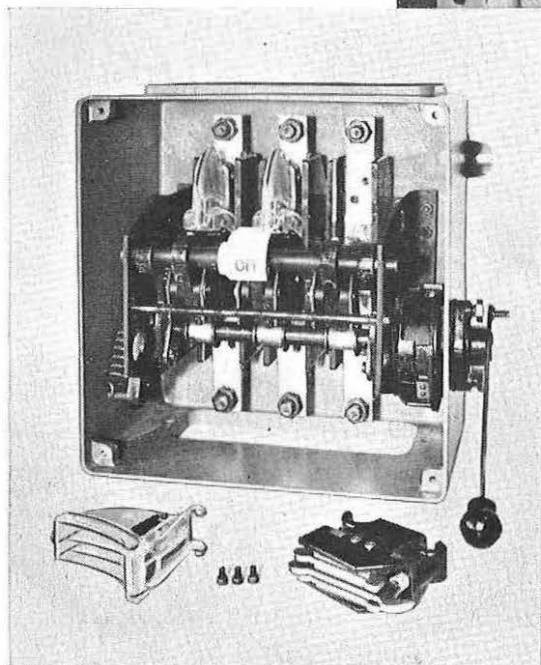
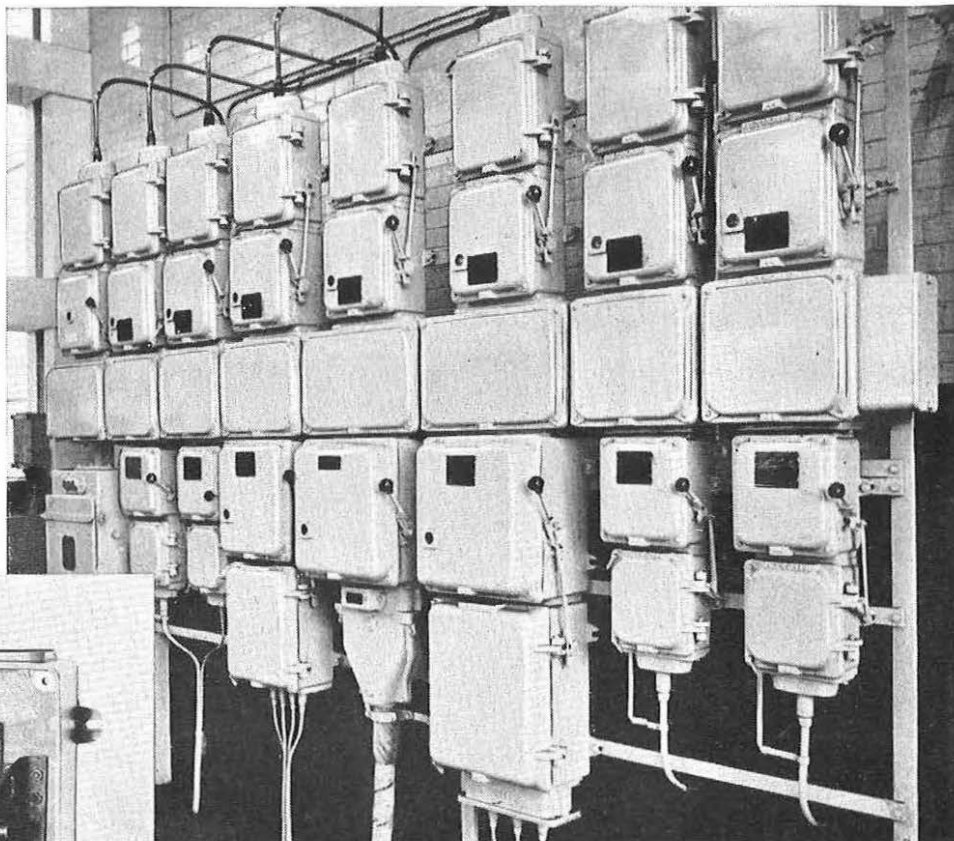

## Arc chutes in 'Diakon' chosen for this 400 amp switch unit

These transparent arc chutes were moulded from 'Diakon' acrylic polymer. That means they have extremely good electrical insulation properties, they are heat resistant and completely non-tracking. 'Diakon' offers all these advantages:—

- \* Precision moulding at low cost.
- \* Low water absorption.
- \* High impact strength.
- \* Dimensional stability in humid atmospheres and at high temperatures.
- \* Clarity and depth of colour available in no other moulding material.
- \* Resistance to staining by nicotine, polishes and chemical products.

*A letter to I.C.I. will bring you more information about this unique material*

### 'DIAKON' POLYMER

*'Diakon' is the registered trade mark for the acrylic polymer manufactured by I.C.I.*

IMPERIAL CHEMICAL INDUSTRIES LIMITED · LONDON · S.W.1



**CATHODEON**



**THE RIGHT TYPES**

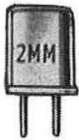

**AT THE RIGHT TIME**

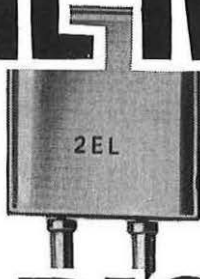

**AT THE RIGHT PRICE**

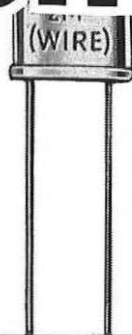

**CATHODEON CRYSTALS LIMITED**  
**LINTON CAMBRIDGESHIRE**  
TELEPHONE LINTON 501 (4 lines)



Moving-in is quicker  
today . . . thanks to  
**PROPAGAS Propane**



*Photograph by courtesy of Chinook Heaters Ltd.*

# PROPAGAS

PROPANE

**PRECISION FUEL**

PROPAGAS propane is the perfect fuel for drying out buildings, heating workshops, stores, repair sheds, working on open sites and pre-heating frozen plants and equipment.

**for air heaters**

PROPAGAS propane and BOTTOGAS butane are the Precision Fuels for industrial furnaces, the glass industry, radiant heaters, bitumen and mastic heating, floodlights, blow-torches, fork lift trucks, agriculture.

*PROPAGAS propane and BOTTOGAS butane come from the British refineries of the Shell and B.P. Groups. They are backed by a nationwide distribution service and technical resources second to none.*

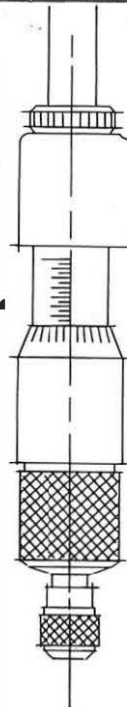

**Shell-Mex and B.P. Gases Limited**  
(Regd. users of Trade Marks)

Cecil Chambers, 76-86 Strand, London WC2 Phone: TEMple Bar 1234

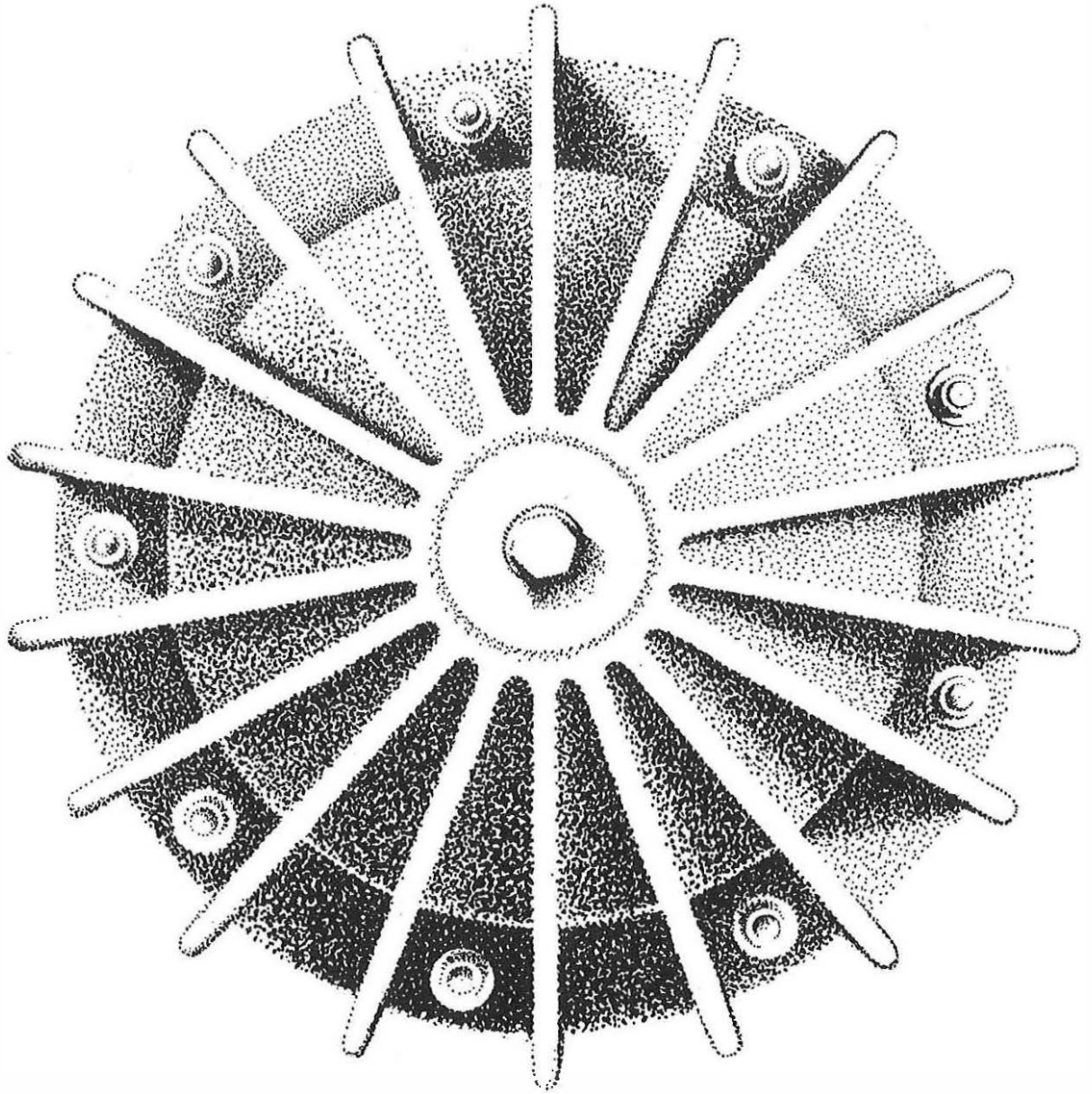

## Wide Band Matching Transformers for H.F.

- Power Capacities 1 kW & 5 kW
- Impedance ratios 600 ohms balanced to 75/50/60 ohms unbalanced

*Compact • no tuning • low loss • weather-proof*

Write for data sheets and further technical details quoting reference AH/687/4 to:—

**MULLARD EQUIPMENT LIMITED**

MANOR ROYAL, CRAWLEY, SUSSEX · Telephone Crawley 28787

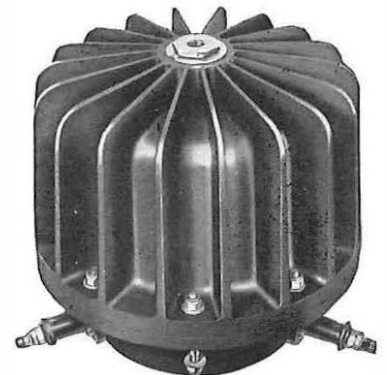

5 kW Type L.382 in cast aluminium.  
Frequency range 1.5-30 Mc/s,  
with VSWR better than 1.5

# TUNGSTONE

**HIGH PERFORMANCE  
PLANTE CELLS**

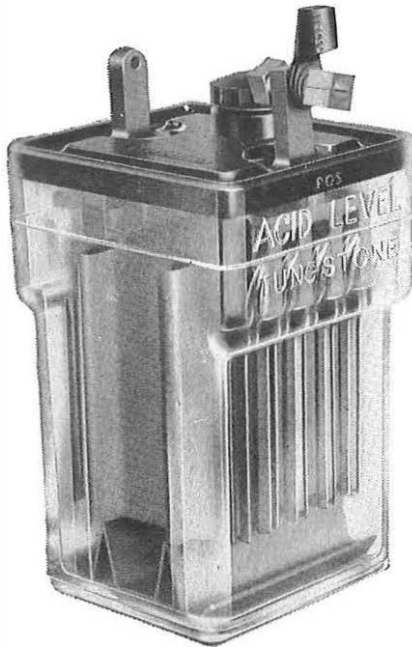

**UP**

**CAPACITY · HIGH RATE OUTPUT**

**DOWN**

**SIZE · WEIGHT · COST**

HA Range 15-60 a.h. HB Range  
75-400 a.h. Have you copies of our latest High  
Performance Cell leaflet?

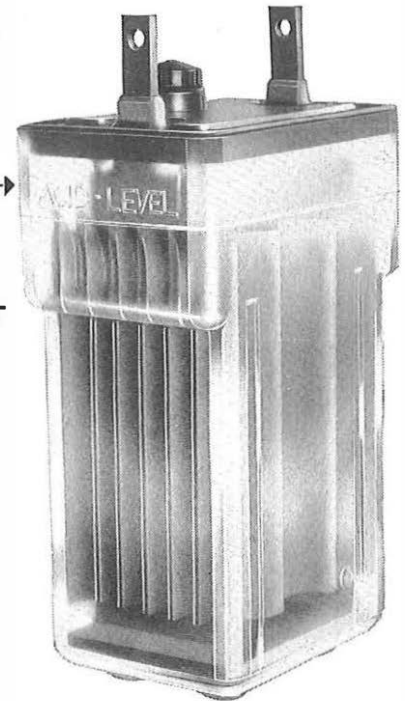

See us at  
**STAND P52**  
at the A.S.E.E.

TUNGSTONE PRODUCTS LIMITED, MARKET HARBOROUGH, LEICESTERSHIRE.

## HOW TO PASS YOUR CITY AND GUILDS TELECOMMUNICATIONS EXAMS - BY POST

The new Bennett College Telecommunications Courses were prepared under the supervision of one of the country's top telecommunications men, W. S. Procter, O.B.E., M.I.E.E., F.R.S.E., Chief Regional Engineer, London Telecommunications Region.

The first and second year subjects are:

FIRST YEAR 1. Practical Mathematics. 2. Engineering Science. 3. Engineering Drawing. 4. Elementary Telecommunications Practice.  
SECOND YEAR 1. Mathematics for the Telecommunications A. 2. Telecommunications Principles A. 3. Radio and Line Transmission A. 4. Telephony and Telegraphy A. 5. Line Plant Practice A.

*Other subjects will be introduced later.*

The certificates awarded by the City and Guilds Institute are of special value to employees of the Post Office Telecommunications Branches, and the Radio and Telecommunications industry, whether engaged in the manufacture or the maintenance and operation of Telecommunications apparatus.

Post this coupon off at once for more information

To: THE BENNETT COLLEGE (DEPT. 24WS) Sheffield  
Please send me details of the new Telecommunications Courses

NAME \_\_\_\_\_

ADDRESS \_\_\_\_\_

AGE \_\_\_\_\_

Personal postal tuition through the famous Bennett College!

## MINIATURE AND MICRO- MINIATURE ELECTRONICS

By G. W. A. Dummer, M.B.E., M.I.E.E., and  
J. W. Granville, B.Sc., Ph.D.

This important work, written to cover the major trends in electronic development, includes considerations on design associated with transistorized equipment and gives co-ordinated information on the new types of components and construction techniques now in use and in the process of development for miniature and sub-miniature electronics equipment. Both authors are with the Royal Radar Establishment. 45/- net.

## SOLUTION OF PROBLEMS IN ELECTRICAL MACHINES

By W. J. Potter, B.Sc.(Eng.)Hons.,  
A.M.I.Mech.E., A.M.I.E.E.

In this book the author has collected together graded examples on Electrical Machines many of which are presented as worked examples. The majority have been selected from examination papers of the various bodies. The remainder have either been set by the author or collected by him from different sources. The range of the problems is such that the book will prove valuable both to lecturers and to students working for Higher National Certificate, Final B.Sc.(Eng.), and Parts II and III of the Graduateship Examination of the Institution of Electrical Engineers. 25/- net.

**PITMAN**

Parker St., Kingsway, London, W.C.2

WHEN LENGTHS OF DEEP SEA CABLE ARE HANDLED ABOARD H.M.T.S. MONARCH

*Preformed*

**HOLDS  
THE  
LINE....**



*H.M.T.S. Monarch which has laid the deep sea telephone cable to Canada as part of a projected Commonwealth round - the - world link-up. Photograph by courtesy of H.M. Postmaster-General.*

... because the unique Helical gripping of PREFORMED Dead Ends\* gives low localised stress. It holds the extra high tensile steel core of this revolutionary type cable through *five slip surfaces* without damaging the polythene sheath. This is an outstanding example of the extreme holding power of PREFORMED Dead Ends. Easily and quickly applied—PREFORMED Dead Ends are the discerning engineers choice.

Other Preformed Products Include:

**LINE GUARDS**—for conductor protection at insulators

**LINE SPLICES**—full tension joints

**PATCH RODS**—for repair of strands

**GUY GRIP Dead Ends**—the most economical way of making-off stays

**ARMOR GRIP SUSPENSION ASSEMBLY**—a revolutionary suspension clamp

**SPLICE SHUNTS**—for overheated joints

**BUNDLED CONDUCTOR SPACER UNITS**—the best twin conductor spacer

\*Patent Application Number 817535

Send for Technical Brochure available in ENGLISH, FRENCH, GERMAN or SPANISH

**PREFORMED LINE PRODUCTS**

(GREAT BRITAIN) LIMITED

ANDOVER · HAMPSHIRE · ENGLAND · TELEPHONE · ANDOVER 4045

Other products mentioned are covered by patent and patent application Nos. 817055, 817534, 805333, 817643, 817644, 788908, 817535

Agents in Countries Throughout the World

Manufactured under licence from PREFORMED LINE PRODUCTS CO., CLEVELAND, OHIO, U.S.A.

H.P. 8497





G.N.T. Tape Reader Model 22

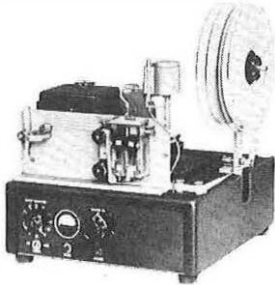

G.N.T. Undulator Model 311

# G.N.T.

## INSTRUMENTS

- Complete range of Wheatstone equipment
- Complete range of special Morse training equipment
- G.N.T. 5-unit Transmitters with one or two sensing heads
- G.N.T. Converters for Morse or Cable Code to 5-Unit or 5-Unit to Morse or Cable Code
- G.N.T. Tape Readers for 5, 6, 7 or 8 Unit Tape

# GREAT NORTHERN TELEGRAPH WORKS

4 SYDHAVN PLADS  
COPENHAGEN DENMARK

LONDON OFFICE:  
5 ST HELENS PLACE EC3



## SOMETHING NEW for MANUFACTURERS !

**BONDED FERROBA**, a permanent magnet material comprising barium ferrite in a base of P.V.C. or rubber and having the properties of those materials. Extruded into strip. Callendered into sheet. Semi-flexible. Machinable. High electrical resistance.

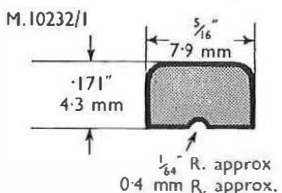
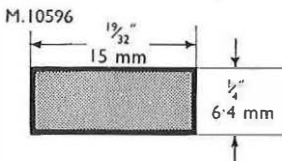
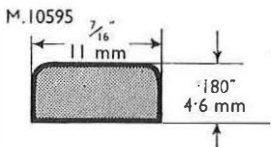
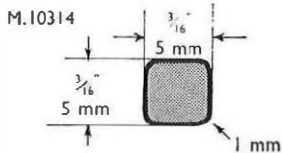

Magnetic characteristics appropriate to very short magnetic lengths and very great cross sectional areas. Not liable to magnetic damage by careless handling. Can be magnetised many ways. High flux densities achievable by concentration in soft pole pieces.

### ECLIPSE MAGNETIC PLASTIC STRIP.

Several standard sizes are illustrated. M.10314 was developed for television corrector magnets. M.10232/1, M.10595 and M.10596 are suitable for repulsion and attraction duties, including door closures. Grip vastly superior when incorporated in magnetic "sandwiches". Supplied in strip or in form of finished magnets, in both cases magnetised. Ask for Eclipse Bulletin M.29.

### ECLIPSE PLASTIC SHEET MAGNETS.

Two standard thicknesses, .032" (1/32") = 0.8 mm. and .065" (1/16") = 1.6 mm. Typical uses are picture shift magnets in television, rotors in electric clocks, arc blow-outs, and oil filters. Supplied in form of finished magnets, magnetised ready for use. Ask for Eclipse Bulletin M.30.

	B <sub>rem</sub> (Gauss)	BH <sub>max</sub> (MGO)	H <sub>Bc</sub> (Oersteds)
BONDED FERROBA	1400	0.4	1150
Alcomax III (The generally accepted standard of reference for all magnets).	12,500	5.1	670

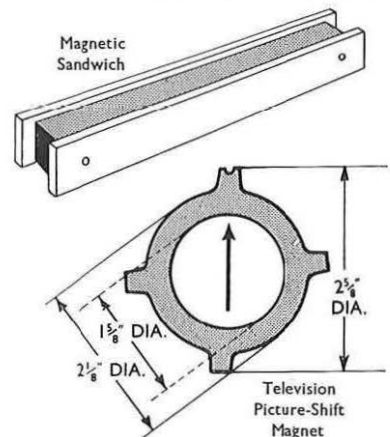

Available to manufacturers in bulk, from James Neill & Co. (Sheffield) Ltd. Napier Street, Sheffield !!

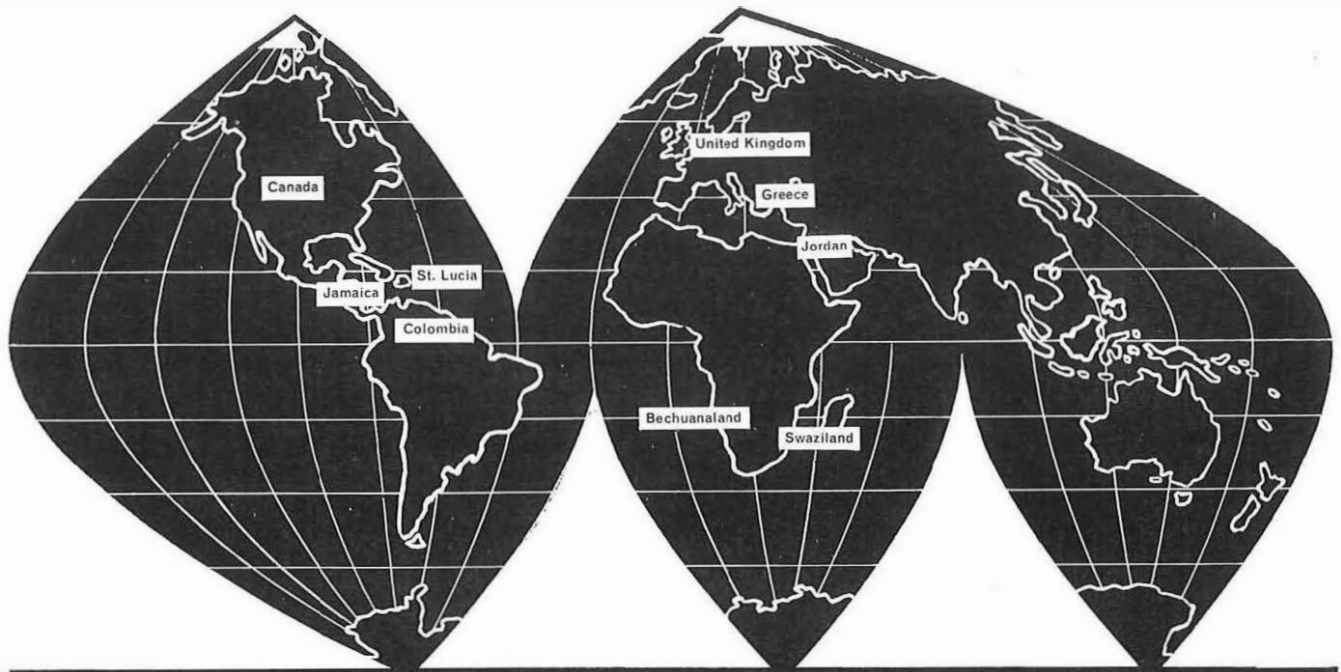

# ERICSSON RURAL CARRIER EQUIPMENT

## TYPE R.C. 101

LOWER POWER CONSUMPTION

BATTERY OR OPTIONAL MAINS OPERATION

TRANSMITTED CARRIER FOR AUTOMATIC  
GAIN CONTROL AND SIGNALLING

INTERCHANGEABLE SIGNALLING UNITS

TRANSISTOR CIRCUITS

COMPANDOR UNITS OPTIONAL

AMPLE TEST POINTS

ONE 10 CHANNEL TERMINAL  
ACCOMMODATED ON A WALL MOUNTING  
RACK 3'3" HIGH

SIMPLE INSTALLATION

PORTABLE TEST SET AVAILABLE

Illustrated opposite is a single channel  
terminal (less panel cover) with mains  
power unit and compandor units fitted.

For further information please write to:-

Now operating in many countries throughout the world, this equipment is designed to combine ease of maintenance with small physical size and low power consumption. It is particularly suitable for use in remote areas where the number and ability of personnel available to service carrier equipment may be limited. Faults can be cleared by substituting a spare for each plug-in unit in turn until the service is restored.

The system will provide up to ten additional speech circuits on an open wire line. The circuits are stackable and thus extra circuits may be added as demand increases. This feature, together with a wide range of pole mounted "drop-off" filter units, offers a high degree of system flexibility. Channel re-allocation is readily effected by replacement of plug-in sub-units.

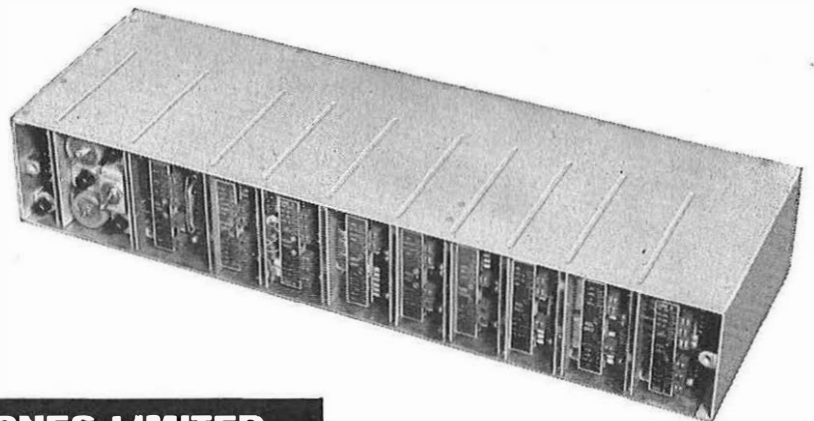

**ERICSSON TELEPHONES LIMITED**  
**ETELCO LIMITED**

Head Office : 22 Lincoln's Inn Fields, London, W.C.2. Tel. HOLborn 6936





## PAINTON KNOBS

- \* Clean functional designs
- \* Strongly made (hard brass inserts)
- \* High grade finish
- \* Keen prices and good delivery

*Send for full details*



# Painton

& CO. LIMITED

KINGSTHORPE · NORTHAMPTON

Tel: 34251 (10 lines) Grams: 'Ceil' Northampton Telex: 31576

# Ernest Turner

## Electrical Measuring Instruments

Ideally matching contemporary panel design, the Ernest Turner Model 703, illustrated here, is enhanced by the flush-fitting surround. A high degree of accuracy is adequately supported by the easy-to-read scale and clean dial layout. Full details of the range of rectangular electrical measuring instruments and flush mountings are contained in Leaflets 85/G and 85/AF, available on request.

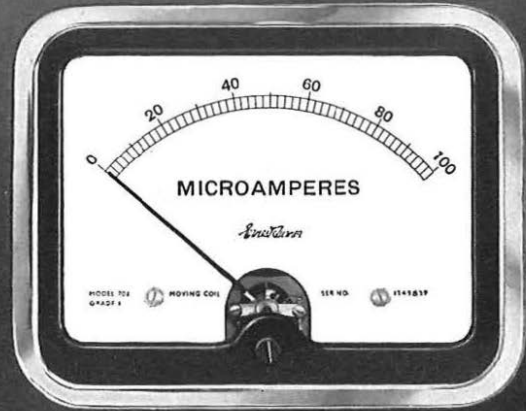

Ernest Turner Electrical Instruments Ltd

HIGH WYCOMBE · BUCKINGHAMSHIRE · ENGLAND

## FLUSH MOUNTING RESETTABLE METERS

This 3 figure meter as adopted for subscriber trunk dialling is an example from a complete range of electro-mechanical counters. Manual and electrical reset types for indication, pre-determined counting, printing and readout are available.



THE STONEBRIDGE ELECTRICAL CO. LTD.

6 QUEEN ANNE'S GATE · LONDON, S.W.1 Telephone: TRAfalgar 1444

CONTROLS & INSTRUMENTS

**STONEBRIDGE**

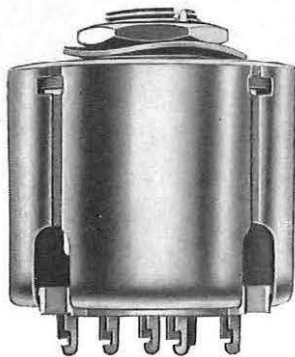
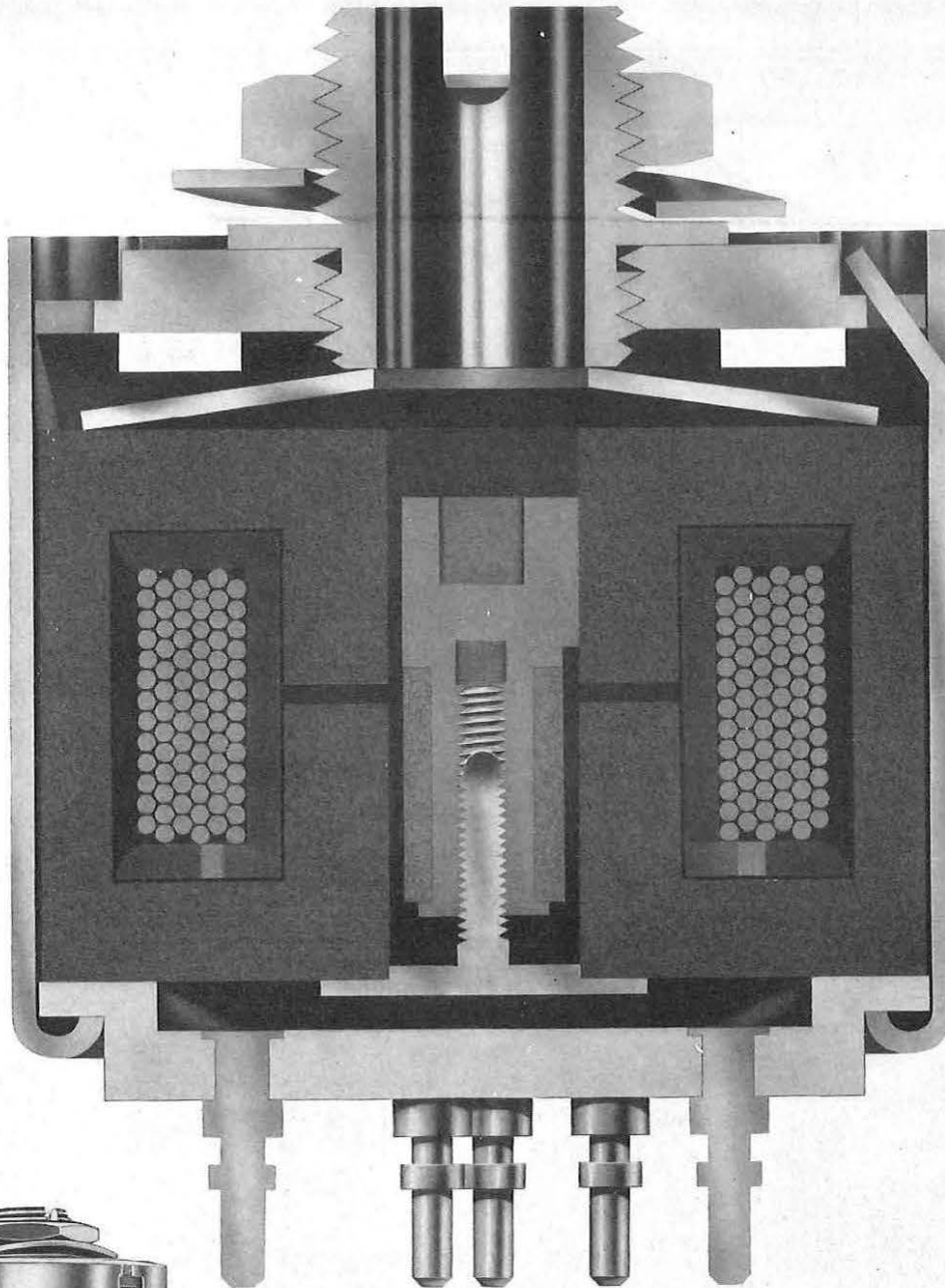

## IF YOU LOOK INTO VINKORS YOU'LL FIND...

- Precise inductance without core grinding
- Easy assembly and setting accuracy of 0.02%
- Adjustment of  $\pm 7\%$
- Eight sizes from 14 mm. to 45 mm.
- Long term stability of 0.1%
- Single hole or printed circuit mounting
- A frequency coverage up to 2 Mc/s
- A temperature coefficient compatible to polystyrene capacitors



**Mullard VINKOR** ADJUSTABLE POT  
CORE ASSEMBLIES

*Write to Mullard House for full technical details of the wide range of Vinkor assemblies*

MULLARD LIMITED, COMPONENT DIVISION, MULLARD HOUSE, TORRINGTON PLACE, LONDON W.C.1.



## VIDEO TRANSMISSION TEST EQUIPMENT

Designed by the British Post Office and engineered by Pye Telecommunications, these precision instruments provide both a signal source and performance indicator in accordance with C.C.I.R. testing standards. They may be used for testing the performance of broad band microwave link systems, coaxial cable systems and studio equipment.

**Pulse and Bar Generator, PTC 1201/3.** This generator produces a composite test signal consisting of a sine squared pulse and smoothed half line bar with line synchronising pulses, and is used for testing the transmission quality of video circuits. Models are available for use with either 405 or 625 line systems.

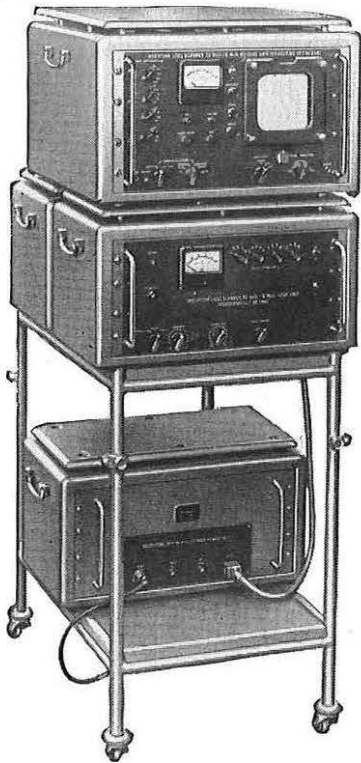
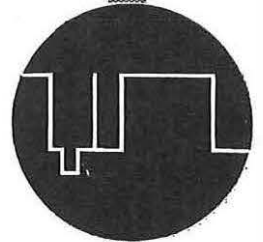
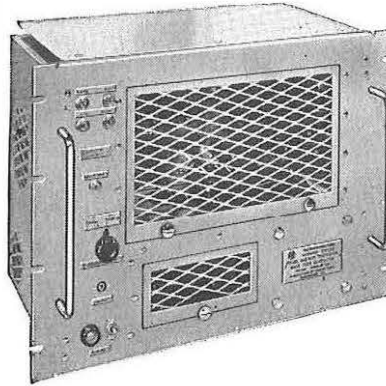

**Video Transmission Oscilloscope, PTC 1205.** This is a precision oscilloscope designed to work in conjunction with the PTC 1201/3 Pulse and Bar Generator and is suitable for use on 405, 525, or 625 line systems. Special features include calibration of amplitude and frequency, calibrated delay scan, hum filter, 10 kc/s square wave oscillator and timing wave generator frequencies of 1, 6, and 10 Mc/s.

**Insertion Loss Scanner, PTC 1206.** This equipment measures the insertion loss/frequency response in the range of 50 kc/s to 8 Mc/s. Both cathode ray tube presentation and pen-recording of the response characteristics are provided. It can be employed to make local or loop tests when the Send and Receive units are at any one location, and unidirectional tests when they are separated by a considerable distance.

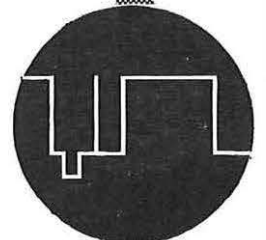
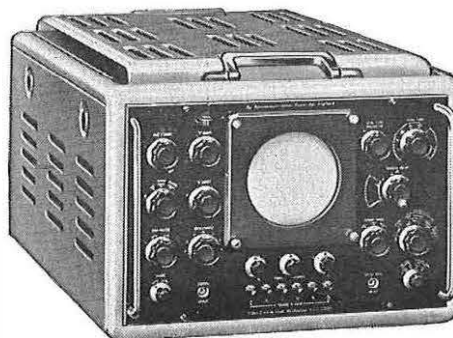
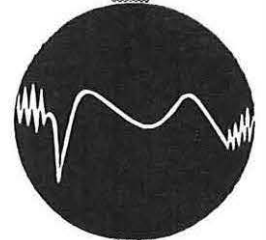

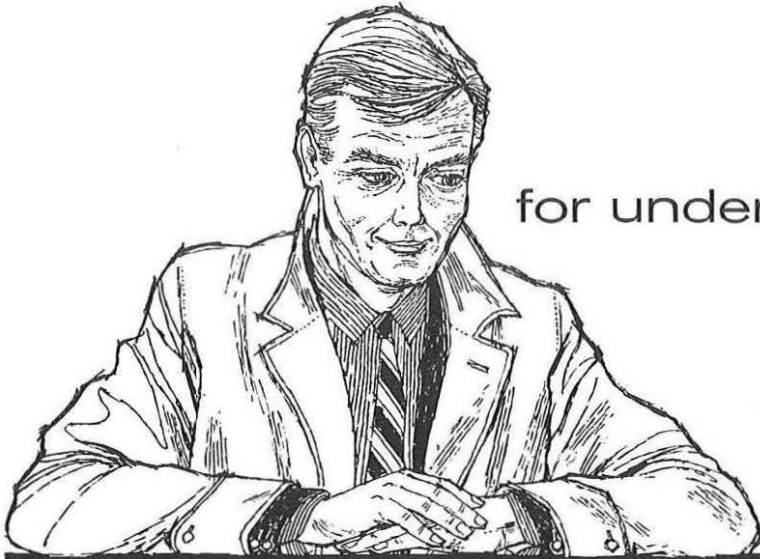

for underground security...

# Glazed Vitrified Clay Conduits

Our telecommunications—lighting systems and power lines are vital. For permanence—how right to use **glazed vitrified clay conduits**—there is no adequate substitute.

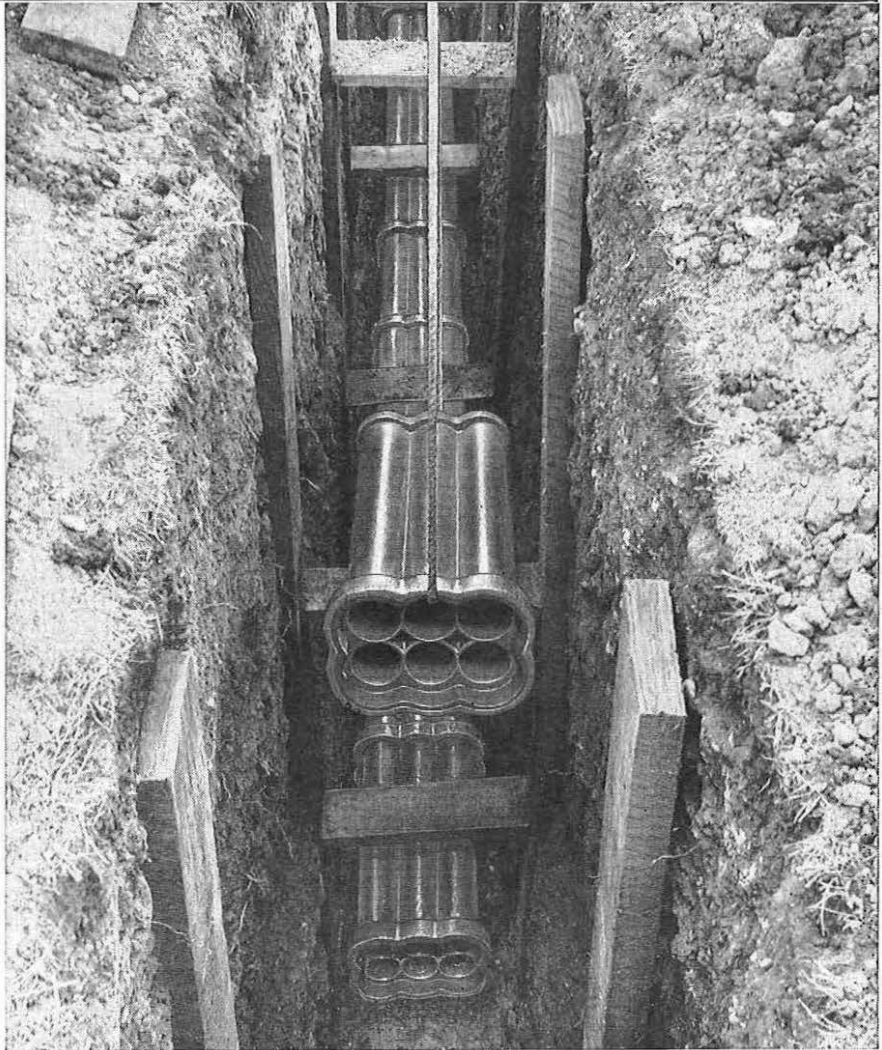

*For information write to the Engineer*

**NATIONAL SALT GLAZED PIPE MANUFACTURERS' ASSOCIATION**

Hanover Court, Hanover Square, London, W.1.

Telephone: MA Yfair 0364



**WHITELEY**  
manufacture  
a wide range  
of



**electronic  
equipment**

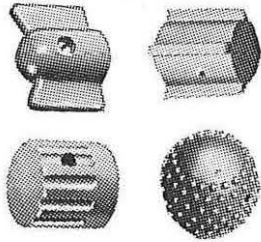

**plastic  
mouldings**

**and  
encapsulated  
components**



**get  
in touch  
with us  
NOW!**

The items shown here are representative of the extensive variety of products manufactured by the Whiteley organisation. Our technical resources are available for the development and production of specialized components for the electronic industry.

**WHITELEY ELECTRICAL RADIO CO LTD**

MANSFIELD · NOTTS · Telephone: Mansfield 1762-5

WB164

**VALUABLE FREE BOOK**

**Tells You How to Pass Your C. & G. or Promotion Exam. at First Attempt!**



All Post Office personnel who are anxious to obtain early promotion should at once send for a copy of our handbook "ENGINEERING OPPORTUNITIES" which, among other intensely interesting matter, describes our unique methods of preparation for the G.P.O., LIMITED COMPETITIONS for appointment as Assistant Engineer, Executive Engineer, Traffic Officer, Telecommunications Traffic Superintendent; CITY AND GUILDS EXAMINATIONS for the Telecommunication Technicians' Certificate and for individual subjects—Mathematics, Engineering Science, Engineering Drawing, Elementary Telecommunication Practice, Telecommunication on Principles, Radio and Line Transmission, Telegraphy and Telephony, Line Plant Practice. It also contains details of our courses covering the City and Guilds Examinations in Electrical Engineering Practice, the Grad. Brit.I.R.E. and A.M.S.E. Examinations, in addition to a wide range of non-examination courses in all branches of engineering—Radio and Electronics, Electrical, Mechanical, etc.

**We also provide tuition for the Radio Amateurs' Examination and the P.M.G. Certificates for Radio Operators, with or without Morse training. Details are given in the handbook.**

**We definitely guarantee  
"NO PASS—NO FEE"**

If you intend to make the most of today's opportunities, you cannot afford to miss reading "ENGINEERING OPPORTUNITIES." It tells you everything you want to know to secure advancement, and describes many opportunities you may now be missing through lack of information. Send for your copy today—FREE and without obligation.

**BRITISH INSTITUTE  
OF ENGINEERING TECHNOLOGY**  
369 COLLEGE HOUSE,  
29-31 WRIGHT'S LANE, LONDON, W.8

**BIET**

**The  
CARPO GRAMME GAUGE**

for  
accurate  
measurement  
of tension  
on Contacts,  
Relays,  
Switchgear,  
etc.

**INCORPORATES MAXIMUM  
READING INDICATOR AT  
NO EXTRA COST**

The Carpo Standard Model incorporates both tolerance indicators and maximum reading indicator, allowing an accurate reading to be taken when the gauge itself is not visible. A robust but highly sensitive instrument acting in both directions. The 5 gramme model has jewelled movement. Two models cover ten pressure ranges.

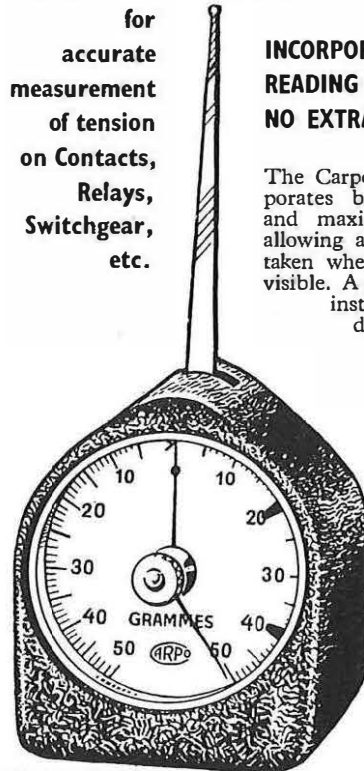

Made under  
licence from Correx

5 GRAMME MODEL  
£3 15 0

SMALL MODELS:  
£3 10 0 and £3 15 0

LARGE MODELS:  
£7 15 0 and £9 15 0

Special discounts for  
large quantities

Write or 'phone for  
illustrated leaflet

OBTAINABLE FROM

**J. P. FILHOL LTD.** MILLERS ROAD, WARWICK  
TELEPHONE: WARWICK 559

MANUFACTURERS OF JEWEL BEARINGS AND PRECISION TURNED PARTS

# THERE'S A WORLD OF EXPERIENCE IN EVERYTHING MARCONI'S DO



*The Post and Telegraph Authorities of more than 80 countries  
rely on Marconi telecommunications equipment*

**SURVEYS** ★ Marconi's telecommunications survey teams are at work in many parts of the world. Marconi's is the only company maintaining a permanent research group working entirely on wave propagation.

**INSTALLATION** ★ Marconi's installation teams undertake complete responsibility for system installation, including erection of buildings and civil engineering works as well as the installation of the telecommunications equipment and auxiliary plant.

**PLANNING** ★ Marconi's vast experience is reflected in the quality of its system planning organisation which is constantly employed on planning major telecommunications systems for many parts of the world.

**MAINTENANCE** ★ Marconi's provide a complete system maintenance service and undertake the training of operating and maintenance staff, either locally or in England. Marconi's will also establish and manage local training schools for Post and Telegraph Authorities.

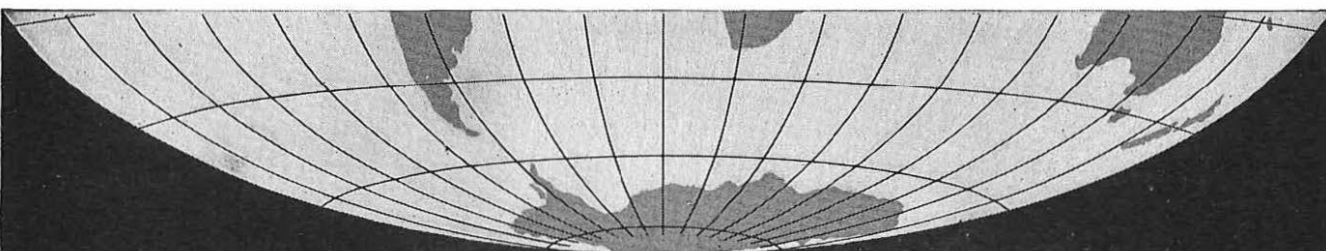

## MARCONI

COMPLETE COMMUNICATIONS SYSTEMS SURVEYED, PLANNED, INSTALLED, MAINTAINED

COMMUNICATIONS DIVISION, MARCONI'S WIRELESS TELEGRAPH COMPANY LIMITED, CHELMSFORD, ESSEX, ENGLAND.

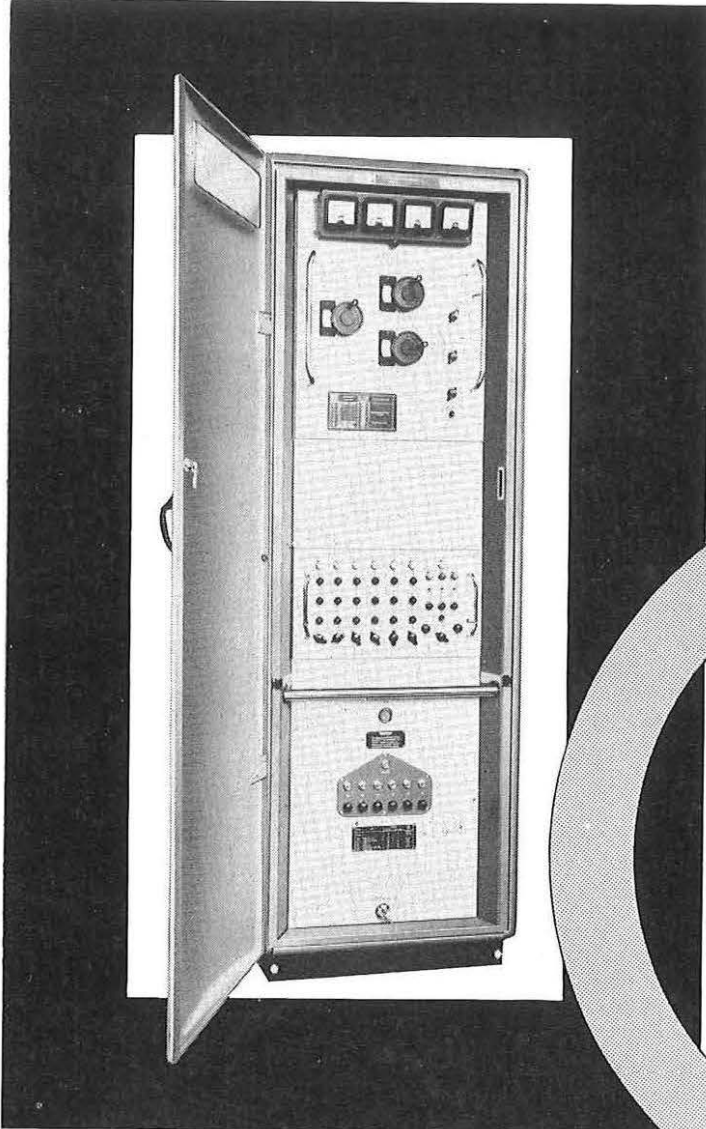

**Plessey**

**1 kW Linear  
Transmitter  
continuously  
tunable from  
1.6–27.5 Mc/s**

\* The Amplifier (Type PA230) provides at least 1 kW radiated power on CW (A1); DSB (A3); SSB (A3A); ISB (A3B); FSK (F1) and Diplex (F6), over the range 1.6 to 27.5 Mc/s.

\* Integral frequency generator drive unit (Type PF211), or 3.1 Mc/s converter unit (Type PF210) available.

\* Radiation of all harmonics at least 60 dB down on fundamental over entire frequency range.

\* Only three calibrated tuning controls for rapid manual frequency changing. Rectifiers contain no thermionic valves.

\* Auto-tune facilities for local or remote control selection of six preset channels.

\* Direct reading of forward and reverse aerial power for feeder VSWR measurement.

**Plessey**

Telecommunications Division Electronic & Equipment Group

THE PLESSEY COMPANY LIMITED • Ilford • Essex • Telephone: Ilford 3040

Overseas Sales Organisation: Plessey International Limited



**More** for less...

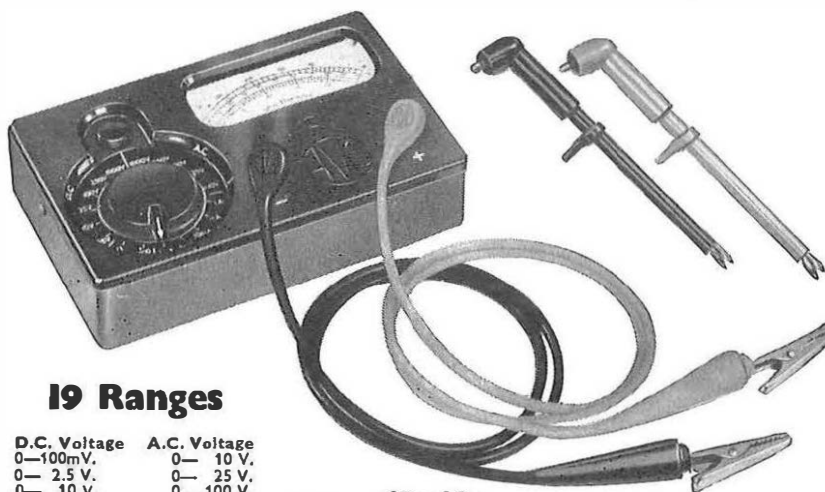

### 19 Ranges

<b>D.C. Voltage</b>	<b>A.C. Voltage</b>
0—100mV.	0—10 V.
0—2.5 V.	0—25 V.
0—10 V.	0—100 V.
0—25 V.	0—250 V.
0—100 V.	0—1000 V.
0—250 V.	
0—1000 V.	
<b>D.C. Current</b>	
0—100μA	
0—1mA	
0—10mA	
0—100mA	
0—1 A	
<b>Resistance</b>	
0—20,000Ω	
0—2MΩ	

List Price: **£9 : 10s.**

complete with test Leads  
and Crocodile Clips.

Leather case if required 39/-

Size 5½ × 3½ × 1½ in.  
Weight: 1 lb. approx.

DESIGNED to offer the widest possible range of accurate and reliable measurements at the lowest possible price, the versatility and usefulness of the Multiminor are further extended by specially designed leads. These leads, available at no extra cost, will accept crocodile clips or PRODCLIPS.

The Multiminor takes full advantage of the possibilities of printed circuit techniques to achieve outstanding compactness and economy of weight. The scale is clear and open. The fine red coloured pointer and effectively damped movement facilitate easy and rapid reading.

For use in Radio, TV, Electronics, Motor Vehicles, domestic appliances, workshop equipment, you'll find the Multiminor a great little meter!

**Use PRODCLIPS with the Multiminor (Pat. No. 748811)**

These cleverly designed spring-loaded insulated prods are the complete answer to a long-standing problem. Press the trigger to open, release to grip. Keep your hands free no matter how difficult of access your test points may be! **15/- per pair**

...with the

# MULTIMINOR

Write now for illustrated literature to:

**AVO LTD** AVOCET HOUSE · 92-96 VAUXHALL BRIDGE ROAD  
LONDON S.W.1

Victoria 3404 (12 lines)



\* for plugging, sealing, caulking

# DENSO MASTIC

THE ALL PURPOSE  
COLD APPLIED  
SEALING MEDIUM

below ground, above ground . . . or under water



**WINN & COALES LTD**

DENSO HOUSE CHAPEL ROAD  
LONDON S.E.27

Agents throughout the Commonwealth

London—Tel: GIPsy Hill 7511  
10 lines

Manchester—(Also Contracting  
Dept.) Tel: Sale 8271

Belfast—Tel: 56623

Dublin—Tel: 61768

## INDEX TO ADVERTISERS

	PAGE		PAGE
Adcola Products, Ltd. . . . .	12	Neill, James, & Co. (Sheffield), Ltd. . . . .	29
Aircraft-Marine Products (Gt. Britain), Ltd. . . . .	22	Newmark Instruments, Ltd. . . . .	42
Automatic Telephone & Electric Co., Ltd. . . . .	4	Oxley Developments Co., Ltd. . . . .	12
Avo, Ltd. . . . .	39	Painton & Co., Ltd. . . . .	31
Bennett College, The . . . . .	27	Pitman, Sir Isaac, & Sons, Ltd. . . . .	27
British Institute of Engineering Technology . . . . .	36	Plessey Co., Ltd., The . . . . .	38
Cathodeon Crystals, Ltd. . . . .	24	Preformed Line Products (Great Britain), Ltd. . . . .	28
Drallim Industries, Ltd. . . . .	1	Pye Telecommunications, Ltd. . . . .	34
Ericsson Telephones, Ltd. . . . .	19, 30	Shell-Mex & B.P. Gases, Ltd. . . . .	25
Filhol, J. P., Ltd. . . . .	36	Standard Telephones & Cables, Ltd. . . . .	3, 5, 7, 9, 11, 13, 15
G.E.C. (Telecommunications), Ltd. . . . .	10, 14, 16-17, 18, 20-21	Stonebridge Electrical Co., Ltd., The . . . . .	32
Geat Northern Telegraph Co., Ltd. . . . .	29	Submarine Cables, Ltd. . . . .	8
Imperial Chemical Industries, Ltd. . . . .	23	Telephone Cables, Ltd. . . . .	2
Johnson, Matthey & Co., Ltd. . . . .	41	Tungstone Products, Ltd. . . . .	27
Marconi's Wireless Telegraph Co., Ltd. . . . .	37	Turner, Ernest, Electrical Instruments, Ltd. . . . .	32
Mullard, Ltd. . . . .	26, 33	Westinghouse Brake & Signal Co., Ltd. . . . .	6
National Salt Glazed Pipe Manufacturers' Association . . . . .	35	Whiteley Electrical Radio Co., Ltd. . . . .	36
		Winn & Coales, Ltd. . . . .	39

## MODEL ANSWER BOOKS

CITY AND GUILDS OF LONDON INSTITUTE  
TELECOMMUNICATION TECHNICIANS' COURSE

### TELECOMMUNICATION PRINCIPLES A

### TELECOMMUNICATION PRINCIPLES B

Price 7s. 6d. each. Post Paid 8s.

The following two model answer books, although published for the old Telecommunications Engineering Course, are still useful and are offered at a considerably reduced price.

### TELEPHONE EXCHANGE SYSTEMS I (Telephony and Telegraphy A, Telephony B)

**TELEGRAPHY II**  
(Telegraphy B, Telegraphy C)  
Price 2s. each. Post Paid 2s. 6d.

Orders to  
*The Post Office Electrical Engineers' Journal*  
G.P.O., 2-12 Gresham Street, London, E.C.2

## The Telecommunication

### Journal of Australia

Published three times a year,  
in February, June and October

The Journal provides information and authoritative articles on the telecommunications, broadcasting and television services of Australia.

February 1962 issue (Vol. 13, No. 3): "The Sydney-Melbourne Coaxial Cable System"—full description.

Subscription: 8 shillings (sterling) or 10 shillings (Australian) per year, commencing with the June issue.

Single copies: 3 shillings (sterling) or 4 shillings (Australian)

Orders and remittances to Telecommunication Society of Australia:—

*European Representative* or *General Secretary*

Mr. A. Kellock,  
c/o P.M.G.'s Representative,  
Australia House,  
Strand, London, W.C.2.

Box 4050 G.P.O.,  
Melbourne,  
VICTORIA,  
AUSTRALIA.

# SILVER STAR

## encapsulated

# CAPACITORS

Recent additions to the range of JMC Silver Star precision silvered-mica capacitors are four synthetic resin encapsulated types. The encapsulation technique, in conjunction with Silver Star fired construction, ensures outstanding long-term and cyclic stability.

The square sectioned A15E and A25E have been designed specially for transistorised circuitry, while the C22E and C33E have been developed for use in filters and other professional equipment. All are ideal for use on printed circuits.

- ★ Fired construction
- ★ Exceptional long term and cyclic stabilities
- ★ Service temperature range  $-55^{\circ}\text{C}$  to  $+100^{\circ}\text{C}$
- ★ Synthetic resin encapsulated
- ★ Excellent humidity resistance
- ★ Low power factor and high insulation resistance
- ★ Remarkably small size
- ★ Precise body dimensions
- ★ Ideal for printed circuitry

Dimensions and capacitance ranges of each type are given below:

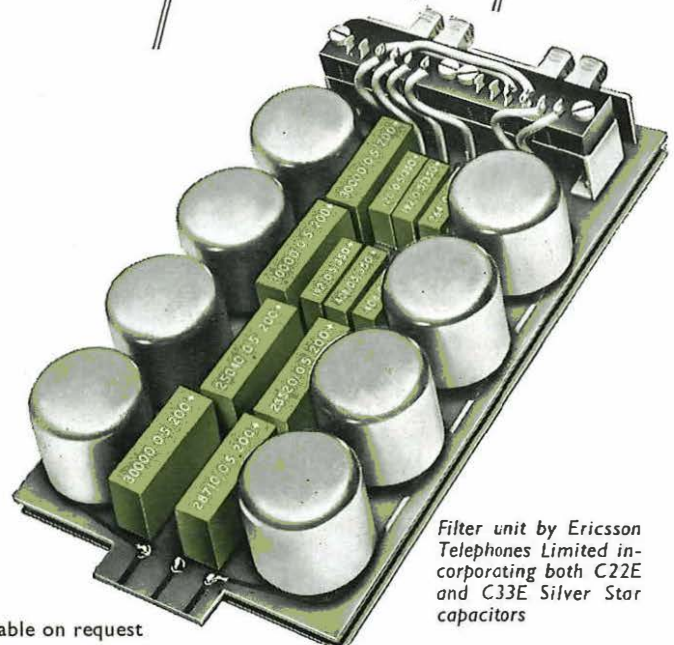
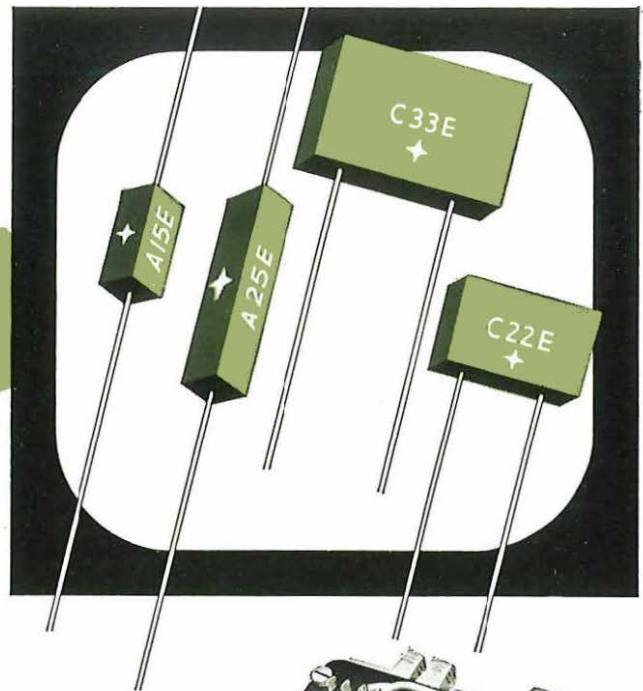

Filter unit by Ericsson Telephones Limited incorporating both C22E and C33E Silver Star capacitors

Data sheets available on request

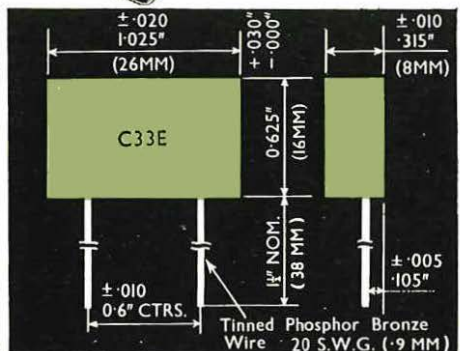
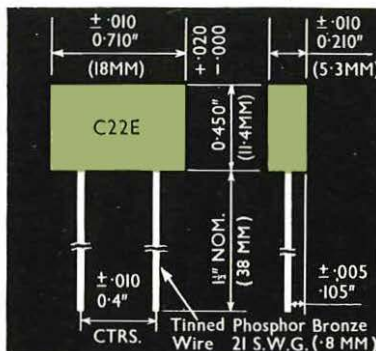
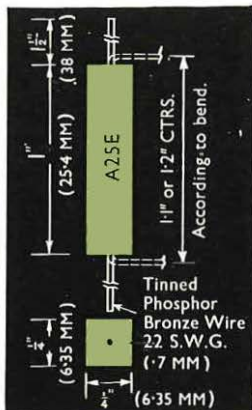
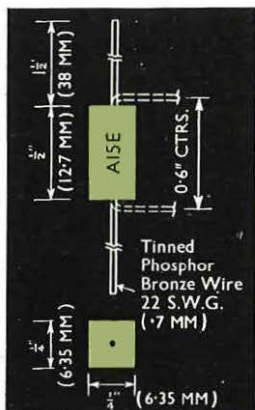

Capacitance Range  
33 to 6,000 $\mu\text{F}$ .  
Minimum Tolerance  
(above 100 $\mu\text{F}$ )  $\pm 2\%$   
(below 100 $\mu\text{F}$ )  $\pm 2\mu\text{F}$ .

Capacitance Range  
6,000 to 20,000 $\mu\text{F}$ .  
Minimum Tolerance  $\pm 1\%$

Capacitance Range  
200 volts peak working  
750 to 3,300 $\mu\text{F}$   
350 volts peak working  
5 to 2,000 $\mu\text{F}$ .  
Minimum Tolerance: (above 200 $\mu\text{F}$ )  $\pm 0.5\%$ ; (below 200 $\mu\text{F}$ )  $\pm 1\mu\text{F}$

Capacitance Range  
200 volts peak working  
7,500 to 33,000 $\mu\text{F}$   
350 volts peak working  
300 to 20,000 $\mu\text{F}$

These are only four types from the wide range of JMC Silver Star <sup>(A)</sup> capacitors

**Johnson  Matthey**

**JOHNSON, MATTHEY & CO., LIMITED**  
73-83 Hatton Garden, London, E.C.1. Telephone: Holborn 6989  
Vittoria Street, Birmingham, 1 Telephone: Central 8004  
75-79 Eyre Street, Sheffield, 1 Telephone: 29212

**Aromatic  
Hydrocarbon Indicator**

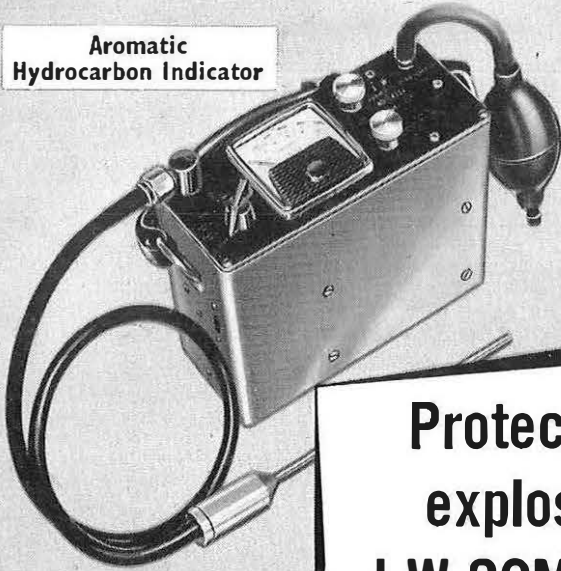

**Gas-Pointer**

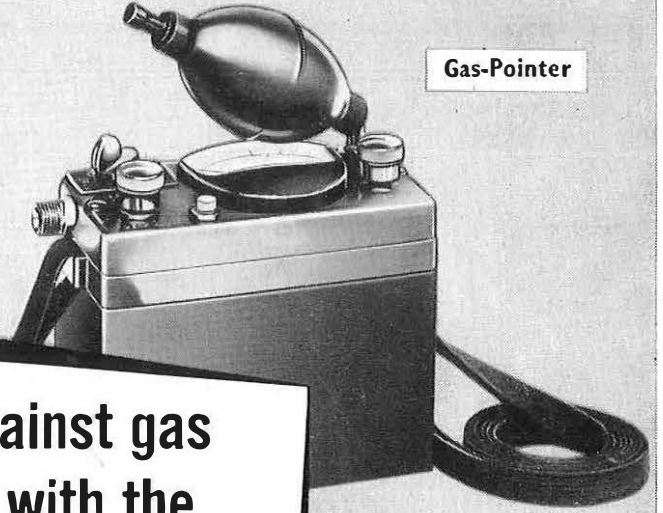

**Combustible  
Gas Indicator**



## Protect against gas explosion with the J-W COMBUSTIBLE GAS INDICATORS & ALARMS

Those who work in industries where explosive and toxic gases can often accumulate, know how vital it is to have adequate warning of combustible vapours. Industries such as chemical processing plants, refineries and various public utilities all require reliable warning systems against gas explosion. Trustworthy performance, efficient design, quality components and painstaking craftsmanship make the J-W range of Newmark Gas Detection Equipment 'synonymous with safety'. Newmark Instruments Limited, who are co-operating with the leading American manufacturers of explosion equipment since 1927, will be pleased to demonstrate how this equipment can be of service to your industry.

*Write to:*

Gas Instrumentation Division  
**NEWMARK INSTRUMENTS LIMITED**  
143-149 Great Portland Street, London, W.1.  
MUSeum 8666

**Combustible Gas Alarm**



**Portable  
Gas Alarm**



**Motor Boat  
Gas Alarm**



**NEWMARK**  
INSTRUMENTS