

THE POST OFFICE ELECTRICAL ENGINEERS' JOURNAL



Vol. 53 Part 4

JANUARY 1961

CONTENTS

	Page
PROTECTION OF EXCHANGE EQUIPMENT AND SUBSCRIBERS' INSTALLATIONS FROM DAMAGE DUE TO LIGHTNING AND CONTACTS WITH POWER LINES—S. J. Little, M.I.E.E.	219
THE TELEPHONE EXCHANGE MAIN DISTRIBUTION FRAME K. W. Hix, A.M.I.E.E.	226
AN INTRODUCTION TO LARGE CORDLESS P.A.B.X.s P. A. Marchant, A.M.I.E.E.	231
I.E.E. CONFERENCE ON ELECTRONIC TELEPHONE EXCHANGES	235
ASSESSMENT OF TRANSISTOR LIFE J. C. Henderson, B.Sc.	236
A RECEIVER FOR DIRECT-PICK-UP TELEVISION LINKS N. A. Elkins, D. E. Mills, B.Sc.(Eng.), A.M.I.E.E., and L. D. W. Fensome	239
A SWITCHING UNIT FOR USE WITH 700-TYPE TELEPHONES—PLAN SET N625 K. M. Akester, B.Sc.(Eng.), A.M.I.E.E.	242
INDUCTION HARDENING OF DIAGONAL-CUTTING NIPPERS H. D. Brook, B.Sc., A.I.M.	247
POLYTHENE-SHEATHED UNDERGROUND TELEPHONE CABLES H. C. S. Hayes, C.G.I.A., M.I.E.E.	250
A MOISTURE BARRIER FOR POLYTHENE-SHEATHED CABLES D. W. Glover, M.Sc., F.R.I.C., and E. J. Hooker, M.A., Ph.D.	253
A NEW CROSS-CONNEXION ASSEMBLY FOR CABINETS AND PILLARS R. W. Hayward, A.M.I.E.E., and F. W. Angell	254
FOUR NEW ENGINEERING VEHICLES A. W. Thomas, A.M.I.Mech.E., A.F.R.Ae.S., and E. R. Collings	257
INTERNATIONAL SYMPOSIUM ON DATA TRANSMISSION, DELFT, 1960	260
DUCTILE PERMANENT-MAGNET MATERIALS G. W. Eastwood, B.Sc., A.Inst.P.	262
EXHIBITION OF SUBSCRIBERS' APPARATUS AND ASSOCIATED EQUIPMENT AT 2-12 GRESHAM STREET, LONDON, E.C.2.	265
EMERGENCY MOBILE TELEPRINTER AUTOMATIC SWITCHING UNITS A. H. Coulman and C. E. G. Goss	268
SIGNAL TRANSMISSION ACROSS THE ATLANTIC VIA A PASSIVE EARTH SATELLITE	270
A 150-FOOT MAST FOR RADIO STATIONS—S. G. Young, B.Sc., A.M.I.E.E.	271
FELLING OF LATTICED STEEL MASTS AT SOMERTON RADIO STATION	274
TESTING FACILITIES ON TEST-DESKS IN AUTOMATIC TELEPHONE EXCHANGES H. C. Adams and L. W. Pratten, A.M.I.E.E.	275
CLOSED-CIRCUIT COLOUR TELEVISION—J. B. Holt, A.M.I.E.E., and R. Gardiner	277
NOTES AND COMMENTS	281
INSTITUTION OF POST OFFICE ELECTRICAL ENGINEERS	282
REGIONAL NOTES	283
ASSOCIATE SECTION NOTES	285
STAFF CHANGES	288
INDEX TO VOLUME 53	291
BOOK REVIEWS	225, 230, 233, 241, 246, 249, 252, 256, 264, 270, 287

Price 2s. 6d. (Post Paid 3s. 6d.)

Published in April, July, October and January by *The Post Office Electrical Engineers' Journal*,
G.P.O., 2-12 Gresham Street, London, E.C.2.

Annual Subscription (post paid): Home and Overseas, 14s. (Canada and U.S.A., 2 dollars 25 cents).

THE POST OFFICE ELECTRICAL ENGINEERS' JOURNAL

Vol. 53 Part 4

JANUARY 1961

Protection of Exchange Equipment and Subscribers' Installations from Damage Due to Lightning and Contacts with Power Lines

S. J. LITTLE, M.I.E.E.†

U.D.C. 621.316.9

The historical development of protective devices fitted at the exchange and at subscribers' premises is surveyed. Three devices, the fuse, the heat coil and the lightning protector, were adopted as standard about 1900 and remained in use, with minor modifications, for many years. These devices were not, however, entirely effective, and had a high fault liability. The changes introduced at various times in an endeavour to overcome these difficulties are discussed and current developments are described.

INTRODUCTION

IN the early days of British telephone development, i.e. before 1895, the only protective component normally fitted at both the exchange and subscriber's termination of a telephone line was a lightning arrester. The most common form consisted of an earthed metal plate with saw-toothed edges placed against, but not touching, the straight edges of plates carrying the line terminations. In 1894, W. H. Preece, later to become Sir William Preece, Engineer-in-Chief, read a paper¹ before the Institution of Electrical Engineers, reporting on a visit he had made to the United States. He stated that protection from lightning and from the danger of fire caused by contacts with electric light and traction wires was obtained by providing all circuits with:

- (a) a fine-wire fuse,
- (b) an air-spaced carbon protector, and
- (c) a heat coil which earthed the line when stray currents exceeded a certain strength.

It seems likely that the principal features of the system of protection then developed were as follows:

(i) A main element (the carbon protector) arranged to discharge excessive voltages.

(ii) A fuse, fitted between the main element and the external line, to limit the current through the main element to earth, it being considered that the relatively small protector would not withstand a prolonged discharge without risk of destruction. The fuse also protected exchange equipment.

(iii) A heat coil to protect internal equipment against small continuous currents which were not large enough to operate the line fuse but were of sufficient magnitude to damage exchange equipment.

Shortly after the presentation of Preece's paper, the three protective components mentioned above were adopted by the British Post Office for the protection of line terminations at its exchanges and at subscribers' premises. The actual components fitted at the ends of a line depended upon the degree of exposure of that line to lightning or power-circuit contacts, and the principles applied appear to have been that lightning protectors were provided if open wires were involved, heat coils and fuses were fitted for wholly underground lines and all three items were considered necessary if the telephone wires were overhead and run in the vicinity of overhead power wires.

Quite apart from protection at the exchange and subscribers' premises it was also the practice to fit fuses on either side of power crossings.

EARLY FORMS OF EXCHANGE PROTECTION

With the adoption of the fuse, lightning protector and heat coil about 1900, the telephone exchange main distribution frame (M.D.F.) was first evolved. Fuses were accommodated on the line side, and lightning protectors and heat coils were located on a unit fitted on the exchange side of the frame. The first type of fuse mounting (Fuse Mounting No. 4002) accommodated narrow glass fuses with slotted end-caps. These fuses were fixed in position by screws (Fig. 1). This type of mounting was superseded by Fuse Mounting No. 4001 (Fig. 2) in 1909.

Fuse Mounting No. 4001 was the standard fuse mounting for local-line pairs for 30 years. A higher standard of insulation resistance and more reliable contacts were, however, found necessary for trunk and junction pairs, and in 1926 Fuse Mounting No. 4028 (Fig. 3) was developed for use on such circuits. In 1939 it was decided that, because of insulation failures and occasional poor contacts with the barrel-ended fuse used on the Fuse Mounting No. 4001, the Fuse Mounting No. 4028 should also be used for local pairs.

So far as the exchange side of the M.D.F. was concerned, the lightning arrestors and heat coils were originally housed in a unit known as Protectors and Heat Coils 40B. This unit did not incorporate testing facilities, and although a unit with such facilities (the Protector, Heat Coil and Test, 40B—Fig. 4) was introduced in 1913,

† External Plant and Protection Branch, E.-in-C.'s Office.

¹ PREECE, W. H. Notes of a Trip to the United States and to Chicago—1893. *Journal I.E.E.*, Vol. 23, p. 40, 1894.

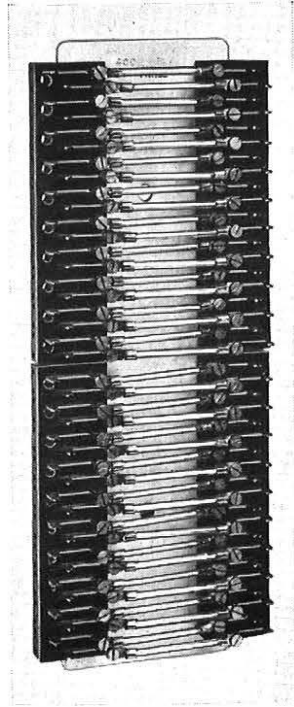

FIG. 1—ORIGINAL TYPE OF FUSE MOUNTING
(FUSE MOUNTING NO. 4002)

it was not until 1936 that this item became the standard for the exchange side of the M.D.F. It is perhaps significant that the extensive failures of heat coils which now occur do not appear to have been in evidence before the inclusion of test facilities on the protector.

Components

The first fuses used in the Fuse Mounting No. 4001 were of the glass-tube type and were rated at 3 amp. However, there was a tendency to serious arcing at such fuses when power contacts occurred and the fuse was redesigned, the fuse wire being enclosed in a small-bore unglazed porcelain tube.

The lightning arrestors of the same period consisted of two small carbon blocks, with a fusible plug cast in the earthed electrode and so arranged that a heavy discharge

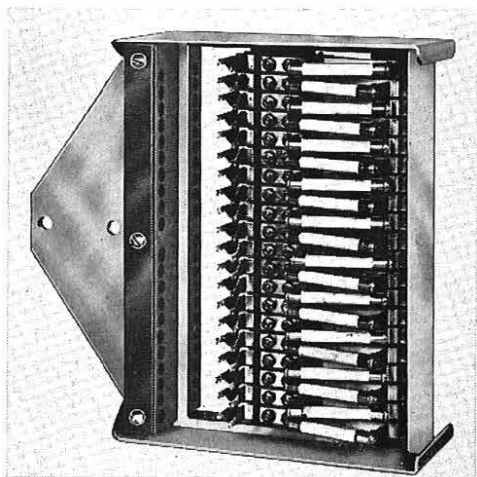

FIG. 2—FUSE MOUNTING NO. 4001

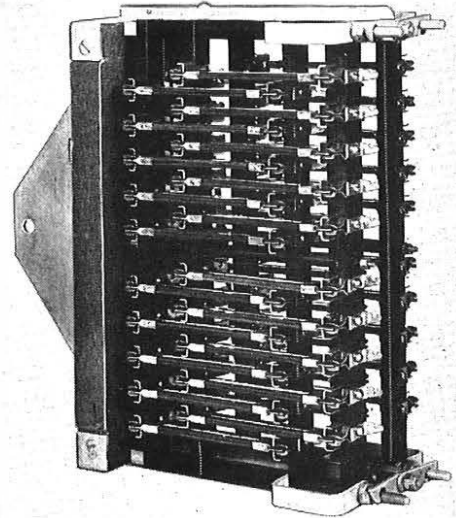

FIG. 3—FUSE MOUNTING NO. 4028

would melt the plug and put the line and earthed electrode into metallic contact.

The carbon blocks were separated by a mica sheet 3 to 4 mils thick, containing three $\frac{1}{8}$ in. holes as spark gaps. This arrangement was superseded by a similar device in which the fusible plug was omitted and the mica spacer replaced by a sprayed coating on the carbon.

The arrangement, characteristics and method of operation of the heat coil were virtually no different from those of its present-day counterpart.

Fault Liability

The three components so long used for protection purposes suffered from a variety of disadvantages. They were particularly susceptible to faults attributable largely

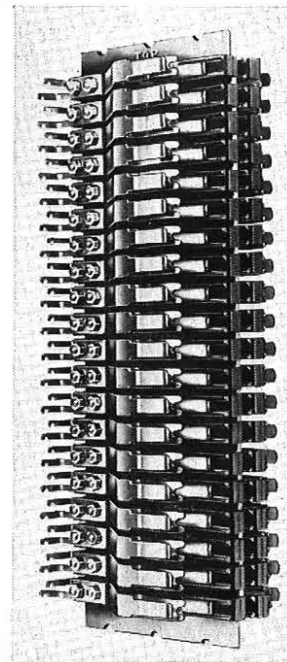

FIG. 4—EXCHANGE PROTECTOR UNIT (PROTECTOR, HEAT COIL AND TEST, 40B)

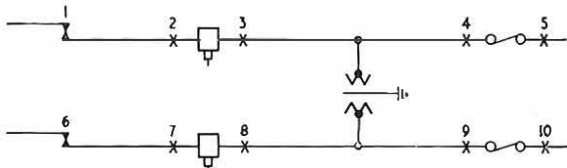

FIG. 5—SERIES CONTACTS INTRODUCED BY PROTECTIVE COMPONENTS

to the number of contacts (10—see Fig. 5) which they introduced in series with each pair of wires.

Although fuses were originally screwed into position, as shown in Fig. 1, clipped-in fuses were subsequently adopted, but they had the disadvantage of variable contact resistances. Furthermore, line-testing operations carried out from fuse mountings tended to distort the fuse springs, producing light spring-pressures and aggravating loose connexions.

The heat coil was also a source of faults. Spring pressures of protector mountings varied, and whilst this did not influence normal operation of the coil, it did affect the tendency of the fusible alloy to "cold flow," with consequent failure of the coils.

Originally, protection against excessive voltage was given by carbon protectors. These tended to disintegrate and cause short-circuits after a few discharges. Short-circuits were also caused when deposits of carbon dust formed between the electrodes. In addition, it was difficult to ensure uniformity of break-down voltage. The position improved when Protector-Electrodes No. 1B, described later, were introduced.

Although the combination of fuse, lightning protector and heat coil has served the Post Office well, the weaknesses described above have, over the years, resulted in several attempts at modification and some of the more important of these will be described.

PAST ATTEMPTS AT MODIFICATION OF PROTECTION

Apart from modifications to the design of fuse mountings, introduced mainly to secure a higher standard of insulation resistance and better contacts, little attempt appears to have been made to change protective arrangements until the early 1930s. It was then realized that the previously accepted methods of protection were not entirely satisfactory, particularly as an increasing proportion of line plant was being put underground.

The problem was investigated, and in 1934 it was recommended that a new protection technique, based on the following proposals, should be the subject of experiment:

- (a) Fuses should be eliminated.
- (b) Heat coils should be provided on all circuits.
- (c) Lightning protectors should be fitted only to circuits having overhead conductors.
- (d) All protective components should be on the line side, and test jacks should be fitted on the exchange side of a new-type M.D.F.

A prototype frame was installed at Worksop in 1938. The protective components were, in fact, all mounted in a withdrawable unit on the exchange side of the M.D.F. In this unit (Fig. 6), heat coils were replaced by delay-action fuses, but the line fuses were retained and a modified form of lightning protector was included. The lightning arrestors operated in the range 500–750 volts; the two line fuses were rated at 1.5 amp

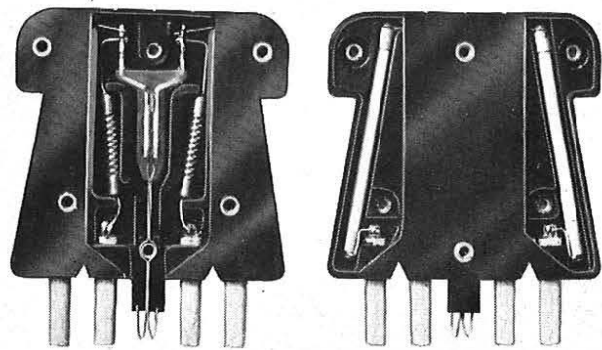

FIG. 6—WORKSOP TRIAL FUSE AND PROTECTOR PLUG

and ruptured in 30 sec with a current of 3 amp at 600 volts. The delay-action fuses operated in 210 sec with a current of 500 mA. The development of this frame did not, however, proceed any further, mainly because of the war.

Development of the Protector-Electrodes No. 1B

During the development of the Worksop M.D.F., attention continued to be directed to the possibility of modifying the protective arrangements at the exchange and at subscribers' premises. One of the components examined was the carbon lightning-protector since this, as outlined earlier, had a number of failings. This examination culminated in the production, in 1938, of a protector having two brass electrodes separated by a 2.3-mil spacer of cellulose acetate, the whole being enclosed in a plastic moulding. As originally designed, this unit had a break-down voltage of 400–600 volts. It was found, however, that it tended to break down when testing voltages were applied to the line and this feature, combined with a desire to relax manufacturing tolerances, resulted in some redesign, the electrode spacing being increased to 4 mils to give a breakdown voltage of 750 ± 150 volts. The redesigned unit was designated Protector-Electrodes No. 1B (Fig. 7).

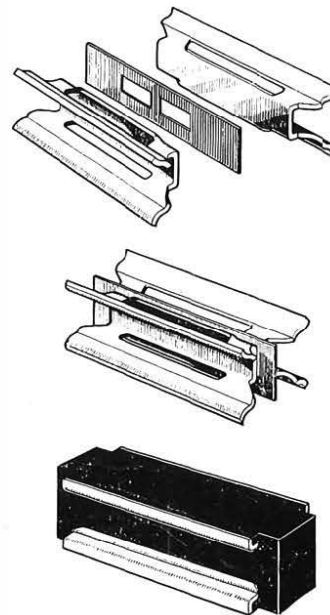

FIG. 7—PROTECTOR-ELECTRODES NO. 1B

Protection of Subscribers' Installations (1937)

In an endeavour to reduce the fault liability of the then standard protector unit for subscribers' installations (Protector, Heat Coil and Fuse, 2/2), consideration was given, in 1937, to the redesign of the unit. At that time, protection at the subscriber's premises was given by fuses rated at 1.5 amp (fusing current 3 amp), carbon protectors and heat coils. Each heat coil was mounted in spring clips and, if a current exceeding 500 mA passed through the coil, the heat generated was sufficient to soften the solder in 15–60 sec. A pin was then pulled out of the bobbin of the heat coil by the action of the spring clip and the circuit was interrupted.

The subscribers' unit, like its counterpart at the exchange, also introduced 10 contacts into the telephone circuit and this, coupled with the tendency of these contacts to corrode, gave rise to many faults. It was considered that if the number of contacts could be reduced by omitting the heat coil, the fault liability of the unit would be improved. It was also found that a number of faults were due to operation of the subscribers' fuses by lightning discharges.

It was ultimately decided that the heat coil could safely be dispensed with, and, to prevent frequent blowing of the fuses by lightning, their rating was increased to 2.5 amp. The lightning protector was, however, retained in the form of the Protector-Electrodes No. 1B.

In order to carry the above changes into effect, a new terminating unit for subscribers' lines was developed (Fig. 8) and this remains the standard unit at the present time.

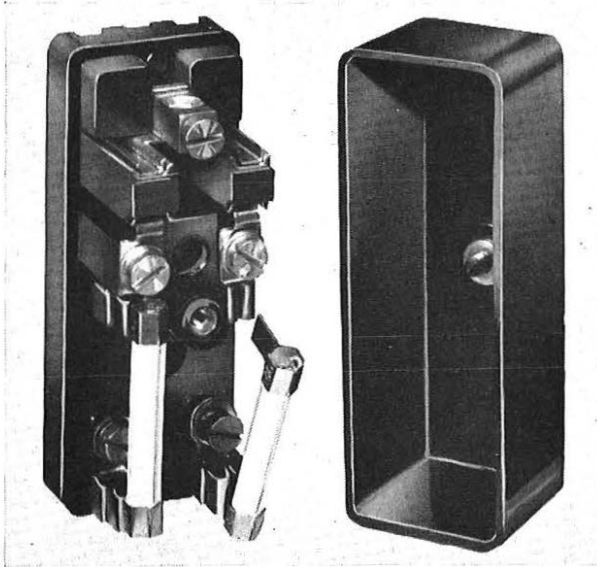

FIG. 8.—PROTECTOR UNIT FOR SUBSCRIBERS' INSTALLATIONS (PROTECTORS AND FUSES NO. 1, 2/2)

War-time Removal of Protection

In the 1940s a shortage of protector units prompted the Belfast Telephone Area to experiment with the omission of protection at the subscribers' ends of lines having only a short overhead component, four spans being fixed as an acceptable limit. No difficulties having been encountered where the technique was adopted, the circumstances were reported and an instruction was subsequently issued that protection could be omitted, with certain exceptions, from the subscribers' ends of lines having

four or fewer overhead spans. Although this instruction was subsequently rescinded, the experience gained during its currency materially assisted in the formulation of the new protection policies described later.

In 1945, a further simplification was attempted when it was decided that it was not necessary to fit protection at the exchange and subscribers' ends of wholly underground lines. It was, however, difficult to segregate such lines on an M.D.F. from those which were not entirely underground, and thus all subscribers' lines have remained fully protected at the exchange. Protection at the subscribers' ends of wholly underground lines is now omitted as standard practice.

Elimination of the Heat Coil at the Exchange

In 1952 the question of protection was again considered and it was concluded that it would be desirable to eliminate the heat coil, provided that its protective function remained covered. This decision implied the availability of a reliable fuse to replace the heat coil. Development work on such a fuse had, in fact, already been carried out at the Post Office Research Station. In addition, a fuse having similar characteristics to the heat coil had been developed in connexion with the Worksop trial mentioned earlier. In this trial, however, it was augmented by a normal line fuse. What was really wanted was a fuse which, in effect, combined the functions of the line fuse and heat coil. The desirable characteristics of such a fuse were considered to be as follows, the corresponding figures for the line fuse being shown for comparison.

<i>New Fuse</i>	<i>Line Fuse</i>
Rated current 200 mA	Rated current 1.5 amp
To rupture within 5–300 sec when carrying 350 mA	To rupture with 3.3 amp within 30 sec
To rupture without fracture or arcing when connected in a circuit carrying 25 amp at 600 volts d.c.	To rupture without fracture at 25 amp, 600 volts d.c.

The heat coil, which the new fuse was intended to supersede, was designed to operate and earth the line in 210 seconds if more than 500 mA flowed in its winding. The most important innovation in the provisional specification for the new fuse was the lower current rating, which, it was suspected, might lead to the fuse being ruptured by normal line-current surges or in inconveniently large numbers during thunderstorms. This point could only be determined by trial in the field.

Fuse manufacturers did not find it difficult to make fuses to the foregoing specification, so a few hundred were made and a small-scale field trial arranged at Birchington exchange. A positive answer was not long in forthcoming from this trial, as the first severe thunderstorm in the area ruptured an unduly high proportion of the trial fuses. This settled the matter for the time being and made it evident that the desired fuse, apart from meeting the foregoing simple specification, must also be less prone to operation in thunderstorms—a fuse, in fact, which would stand a considerable overload for short periods of time.

A line fuse was eventually designed based on a type of fuse already in use in the inputs to power rectifiers. For this purpose delay is necessary to prevent the fuse being ruptured by the switching-on surge. The first fuses

made were put on trial at Birchington exchange with encouraging results. Since then several thousands have been fitted in areas known to be subject to lightning storms and have given satisfactory service.

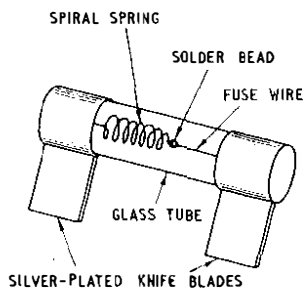

FIG. 9—DELAY-ACTION FUSE

The fuse element of the new fuse (Fig. 9), i.e. the essential operating portion as distinct from the carrier or housing, comprises three distinct parts: a helical spring, low-melting-point solder and fuse wire. Most of the electrical resistance of the element is in the fuse wire which, with sufficient current flowing through it, develops enough heat to melt the solder. On the melting of the solder the spring retracts and the fuse is open-circuited. With large currents the fuse wire will melt.

Although the fuse was originally developed as a 600-volt unit, experience in recent years has shown that the greater risk is now from 415/240-volt 50 c/s a.c. supplies. The new fuse (Fuse No. 64) is therefore rated at 250 volts.

PROTECTION STANDARDS ADOPTED FOR SUBSCRIBERS' INSTALLATIONS IN 1957

In 1957, attention was again directed to the possibility of simplifying the protective arrangements for subscribers' installations fed by lines having an overhead section. At that time, the protective arrangements were as shown in Fig. 10, and it was considered that, if

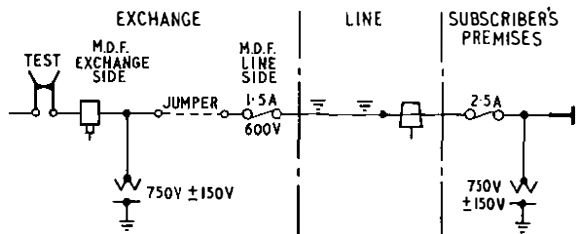

FIG. 10—PRE-1957 PROTECTIVE ARRANGEMENTS

these could be simplified, installation and maintenance costs would be reduced. In particular, it had been found that, with the arrangements then in use at the subscriber's end of a line, there was still a marked tendency for the fuse to be blown by lightning in spite of the increase in fuse rating introduced in 1937.

Examination of the problem showed that there were some grounds for the complete omission of protective devices at the subscribers' ends of lines having only short overhead sections. The only risks additional to those to which a completely underground line was exposed were direct lightning strokes and contact between the open wires and power conductors. Even if such contact should occur, the fuses then fitted at the subscriber's premises did not really safeguard plant at that end since

the resistance of the power-fault-current path, i.e. power transformer, power line, point of contact, telephone line, subscriber's fuse, internal wiring, telephone-instrument earth and earthed neutral of the power system, was usually too high to permit sufficient current to flow to rupture the subscriber's fuse. The major cause of rupture of the fuse was in fact lightning surges through the fuse and lightning protector to earth, and it was this that caused much interruption to service.

The original intention was that the blowing of the fuse would prevent damage to the lightning protector, primarily when power contacts occurred. It also isolated the line from the subscriber's apparatus, which, theoretically at least, was safeguarded against damage. Whether, at least in recent years, the fuse really did what was required is open to doubt. There is, in fact, evidence to the contrary, since it has been observed that the explosive rupture of the fuses when lightning surges occurred often disintegrated protector units. Taking these circumstances into consideration, it was decided to dispense with fuses.

Normal telephone-line lightning protectors cannot be expected to provide protection against a direct lightning stroke to an overhead line but, so far as lines containing only short overhead components are concerned, there is evidence to show that the risk resulting from complete elimination of lightning protection is not great.

Examination of the policies of other administrations has shown that some only provide lightning protection if the line exceeds an appreciable length, e.g. $\frac{1}{2}$ mile.

These policies, coupled with the favourable experience in the United Kingdom during the 1940s, when subscribers' lines having four or fewer overhead spans were not fitted with protection of any kind at the subscriber's end, influenced the decision to modify the standard arrangements. The new standard, adopted in 1957, was as follows:

- (a) Entirely underground circuits—no protection
- (b) Lines with four or fewer overhead spans (including drop wire)—no protection
- (c) Circuits with more than four overhead spans (including drop wire)—only lightning protectors to be fitted at the subscribers' premises.

The new standards were adopted immediately for new installations whilst existing installations were modified at subsequent maintenance visits.

REVIEW OF ARRANGEMENTS FOR PROTECTION OF EXCHANGE EQUIPMENT

The three protective components fitted for so many years on line terminations at the exchange take up a great deal of space, and economies could be realized if these components could be so modified that the physical dimensions of the M.D.F. could be reduced. Furthermore, the characteristics of the fuse, lightning protector and heat coil are such that they do not really safeguard present-day exchange plant satisfactorily. A critical review of the protective components was therefore undertaken, with the following results.

Heat Coils

About 500,000 heat coils are used every year and, although a large number are installed at new exchanges, many replace faulty items on existing M.D.F.s. It was, however, difficult to believe that the latter failures were

all due to small leakage currents, particularly as it was known that the heat coil was prone to mechanical failure.

In an attempt to assess the proportion of mechanical to electrical failures, it was decided to conduct a controlled trial. Four exchanges, each having 1,000-2,000 lines, in areas where low-voltage (415/240-volt) overhead power distribution is extensively used, were selected for the purpose. The heat coils in these exchanges, 14,000 in all, were replaced by new ones and, for purposes of comparison and control, 200 idle heat coils were fitted in unwired protector units (Protectors, Heat Coil and Test, 40B) at each exchange.

The trials continued for two years and 48 coils failed. Forty of these failed mechanically, i.e. they showed no signs of electrical operation. One coil that failed in this way was fitted in an unwired protector unit. Of the remainder, three showed signs of electrical operation that could be related to known power contacts. The remaining five also showed signs of electrical operation, although no power contacts could be traced.

From this evidence there is some doubt whether the heat coil is a good investment, particularly as it has such a high fault liability and is known to be too insensitive to protect equipment adequately.

Complementary to the investigation into the performance of heat coils, information was collected of damage sustained by exchange and subscribers' equipment due to power voltages on Post Office circuits. During this investigation, which lasted for two years, 138 reports of power contacts were received. Of these, 115 recorded damage to exchange equipment; in some instances protective equipment operated, in others it did not.

There were also 34 power contacts which resulted in damage to subscribers' apparatus.

Fuses

One of the functions of the exchange line-fuse is to safeguard personnel and equipment against power voltages and currents appearing on external lines due to contact between those lines and power circuits. In the early days of telephony this risk was primarily from 600-volt d.c. tramway systems. The line fuse was therefore designed to be capable of interrupting the currents which, at that voltage, could be expected to flow when contact occurred between trolley wires and Post Office overhead conductors. Apart, however, from certain isolated systems, tramways are disappearing, and an assessment has shown that the risk is now mainly from 415/240-volt power distribution systems and that there is a case for reducing the voltage rating of the exchange line-fuse from 600 volts to, say, 250 volts. This action makes possible the reduction of the physical dimensions of the fuse, since one designed for 250 volts can be much shorter than one suitable for 600 volts.

Lightning Protectors

For many years it has been customary to fit lightning protectors on lines incoming to an exchange, and although such protection can be omitted from wholly underground lines, it is difficult to segregate such lines on an M.D.F. from those which contain an overhead component. In general, all subscribers' lines have been fitted with lightning protection on the M.D.F. This is a prodigal use of protectors, and economies could be achieved if they were fitted only where really required.

To help decide where such protectors should be fitted, it was arranged that all damage to subscribers' line

plant and equipment due to lightning should be reported and the results analysed. During the period concerned 5,700 instances of lightning damage were reported. Some 5,200 have been analysed and the damage sub-divided into three broad classes:

(a) Subscribers' distribution points (D.P.s) and the cables to them (2,270 faults).

(b) Subscribers' equipment (2,730 faults).

(c) Power crossings (183 faults).

Of the 2,270 cases under (a), over 1,600 occurred in underground lead-sheathed cable, and Fig. 11 shows the distribution. A similar distribution occurred with aerial

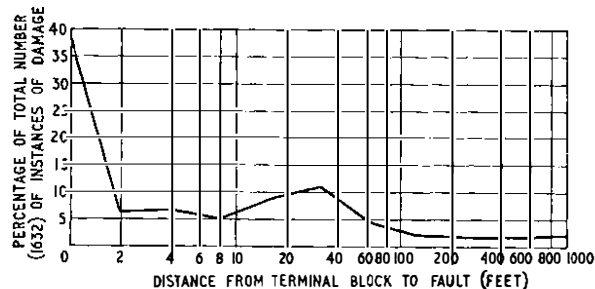

FIG. 11—OCCURRENCE OF LIGHTNING DAMAGE TO METALLIC-SHEATHED UNDERGROUND CABLES

metallic-sheathed cables, which were damaged approximately 400 times. There were also a few instances involving polythene aerial and underground cable.

Damage to D.P.s and their cables causes serious interruption to service and is relatively expensive to repair. It follows that a lightning protector is needed which will divert lightning surges to earth before they get into the cable network, implying that a lightning protector is required at the junction of overhead and underground plant.

NEW PROTECTION STANDARDS FOR EXCHANGES

From the considerations set out in the preceding paragraphs the conclusion was drawn that the old protective arrangements should be superseded by a technique employing, in addition to fuses at the exchange, a lightning protector at the junction of overhead and underground plant. There was, however, some doubt whether lightning protection was really necessary for all overhead lines, and it was decided that, to conform with the practice adopted for subscribers' installations, lightning protectors should only be fitted at the junction of overhead and underground plant when the former exceeded four spans.

As described earlier, considerable effort has been directed towards elimination of the heat coil, and this has resulted in the development of a fuse which should provide better protection than the old arrangements. This fuse was, therefore, incorporated in the revised protective arrangements, becoming the only protective item fitted at the exchange.

The revision of protective arrangements outlined above offered an appreciable saving in space at the exchange, and a new M.D.F. suitable for housing the new fuses has been developed.²

As the foregoing proposals would be far reaching in their results, it was decided to carry out field trials in

² Hix, K. W. The Telephone Exchange Main Distribution Frame. (In this issue of the *P.O.E.E.J.*)

areas known to be specially subject to lightning. In carrying out the trials, it was found that the number of subscribers' lines requiring lightning protection was only a small proportion of those connected to the exchange.

The type of lightning protector to be provided at the pole top was investigated but, at the time, no more suitable item than the standard Protector-Electrodes No. 1B could be found and it was therefore decided that these, mounted in a convenient unit, should be used. For D.P.s to which a number of long external lines are connected, a proprietary unit was provided in place of the standard terminal block. This type of unit will be used until a new item becomes available. If only a few pairs require protection, a protected terminal block is not economic and a unit has been developed for insertion in the head of an insulator.

These arrangements are not the only methods which have been evolved or are in use, but the results of the field trials indicated that the new protective arrangements could be introduced without undue risk. It was, therefore, decided that the new protection standard, so far as exchanges were concerned, should be:

- (a) a fuse in every line at the exchange, and
- (b) pole-mounted lightning arrestors on all subscribers' lines having more than four overhead spans.

Fig. 12 shows the new arrangements.

MAINTENANCE

If the new fuse is found to be as satisfactory in practice as on field trial, internal maintenance costs should be reduced. Improved protection of exchange equipment should also result.

Some concern has been expressed that the cost of maintaining external lightning protectors will more than offset the cost of repairing lightning damage to

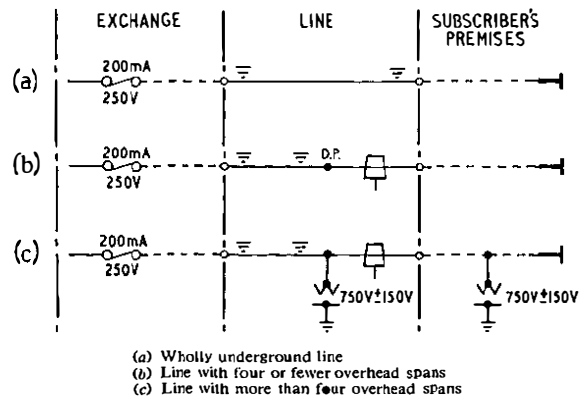

FIG. 12—NEW PROTECTIVE ARRANGEMENTS

D.P.s and their associated cables. In view of the importance of this question further trials of the new protection arrangements are being conducted in the Plymouth and Peterborough Areas, where all exchanges in some maintenance-control areas will be changed over to the new system. Protective arrangements in the remaining maintenance-control areas will, however, remain unaltered and a record of maintenance costs will be kept for the modified and unmodified areas.

ACKNOWLEDGEMENTS

The changes which have been described are the culmination of the work of many past and present members of the Engineering Department over a considerable period. The author wishes to put on record his debt to those officers and to Regions and Areas for assistance in carrying out field trials.

Book Review

"Compression and Transfer Moulding of Plastics." J. Butler, A.M.I.Mech.E., F.P.I. Published for the Plastics Institute by Iliffe & Sons, Ltd. x + 230 pp. 168 ill. 35s.

This is an excellent book for the small minority of Post Office engineers who are concerned with mould design, moulding processes, and the recognition and correction of faults arising from incorrect moulding processes.

The book is intended for students of mould design, designers and shop executives, and its scope is best shown by a list of the chapter headings. Part I, Compression Moulding: 1, Mould types; 2, Relating mould design to moulding; 3, Cavity treatment; 4, Common cavity moulds and moulding; 5, Three plate moulds; 6, Other mould types and other problems; 7, Moulding procedures and problems with urea and melamine powders; 8, Preheating. Part II, Transfer Moulding: 9, History of transfer moulding problems; 10, Evolution of transfer mould design; 11, Feed systems and gate areas; 12, Gate position and feed size; 13, Effect of transfer on strength of mouldings; 14, Transfer and clamping pressures; 15, Split-die problems; 16, High-frequency preheating; 17, Types of moulds; 18, Bolster strains and stresses. The author takes it for granted that the reader is already familiar with the construction and use of hydraulic moulding presses.

The treatment is essentially from a practical viewpoint and sometimes the point under discussion is illustrated by reference to actual mouldings made by the author, or under his instructions. The illustrations show considerable detail in support of the author's contention that "when an engineer writes such a book he has no excuse for omitting important details or for describing or drawing them incorrectly."

In the evolution of transfer-mould design the author adopts the principle of describing a possible mould made for a hypothetical job, indicating ways in which it did not quite come up to the standard of performance desired, and then describing successive modifications made to the design, and the improvements resulting from them, until an entirely satisfactory result was obtained.

Rarely is any specific reference made to the pretreatment and moulding techniques of phenol-formaldehyde materials, although the subject as it applies to urea and melamine powders is given a separate section. This appears to be partly because the author considers all he says to be applicable to phenol-formaldehyde materials unless stated to the contrary. No reference is made to alkyd thermosetting moulding materials.

The book contains 131 very clear line drawings (most of which are, in fact, groups of drawings), 10 graphs, and 27 rather flat and sometimes not very sharp photographic plates.

A. A. N.

The Telephone Exchange Main Distribution Frame

K. W. HIX, A.M.I.E.E.†

U.D.C. 621.315.684:621.395.722

The telephone exchange main distribution frame serves as an interconnecting point between the external street cables and the exchange equipment. The external cables terminate in cable-pair order on the line side of an ironwork frame, and the exchange equipment is connected in subscribers' numerical order on the exchange side. Fuses, heat coils and lightning arrestors have traditionally been mounted in units on this frame. A change in Post Office standards, which reduces the quantity of protective equipment to be provided for each circuit at the exchange, has enabled the frame to be redesigned so that more circuits can be terminated in a given space. Another objective of the new design has been the reduction of the fault liability of the protective and test interception components.

INTRODUCTION

FOR nearly 60 years it has been the practice to terminate subscribers' telephone lines on fuse mountings fitted on one side of an ironwork structure known as a main distribution frame (M.D.F.). The external cable pairs are terminated in numerical order on the fuse mountings on the line side of this frame and are jumpered (cross-connected) to other protective items mounted on the opposite (exchange) side. Although, from time to time, minor changes have been made to ironwork details and to the protective items provided, the frames now being installed do not differ materially from the first M.D.F. installed in the Carter Lane building for the London Central exchange in 1902.

The line fuse has existed in a number of forms, but since 1939 it has been the practice to provide fuses with a rated current of 1.5 amp in a Fuse Mounting No. 4028* on all subscribers' circuits, and the physical size of these items has limited the number of pairs which could be terminated on each unit of the frame to 220 (such units are usually termed "verticals").

On the exchange side of the frame, subscribers' circuits are connected in exchange numerical order to combined test and protective units. Although the testing, isolating and exchange-transfer facilities on this side are important, the units have the primary function of housing protective devices: heat coils to give protection against currents of insufficient magnitude to operate the line fuses but large enough to damage exchange apparatus, and protectors to safeguard the equipment from high voltages and lightning discharges.

Although it has been recognized for a long time that changes in the standard of protection were desirable and that protective components taking up less space would be advantageous, it has not been possible for various reasons to evolve an alternative standard until the present time. A design of M.D.F. based on the new standard of protection described elsewhere in this issue of the Journal‡ is now being introduced.

EARLY DEVELOPMENTS

Revision of protection standards was considered by a Post Office Headquarters committee in 1934 and it was

† Telephone Exchange Standards and Maintenance Branch, E.-in-C.'s Office.

* See Fig. 3 of "Protection of Exchange Equipment and Subscribers' Installations from Damage due to Lightning and Contacts with Power Lines." (In this issue of the *P.O.E.E.J.*, p. 220).

‡ LITTLE, S. J. Protection of Exchange Equipment and Subscribers' Installations from Damage due to Lightning and Contacts with Power Lines. (In this issue of the *P.O.E.E.J.*).

subsequently agreed that there should be an experimental installation to try out new protective items. A novel delay-action fuse to replace the heat coil was designed and a frame incorporating new-type protective units was installed at Worksop exchange in 1938. This frame permitted slightly more circuits to be terminated in relation to its size than a conventional frame and there is no doubt that but for the outbreak of war the development would have been pursued. In the event, the development was shelved and after the war was further delayed whilst efforts were made to produce a delay-action fuse better suited to mass production than the item which had been used at Worksop. The developments leading to the introduction of the new type of fuse (Fuse No. 64), which will be used in future, are described elsewhere in this issue of the Journal.‡

SPRINGPARK EXPERIMENT

In parallel with the development of the new type of fuse, consideration had been given to alternative physical forms for the supporting framework, but no acceptable design had been evolved by the time it was decided that the fuse under trial was sufficiently promising to justify its provision in a complete exchange installation. It was accordingly decided that new fuse units should be developed to mount on the existing type of M.D.F. ironwork, and an exchange in the London Telecommunications Region (Springpark) was chosen to be the first exchange equipped to the new standard of protection. This exchange came into service in October 1959, and its M.D.F. has facilities for terminating 440 pairs per vertical on the line side and 300 pairs per vertical on the exchange side.

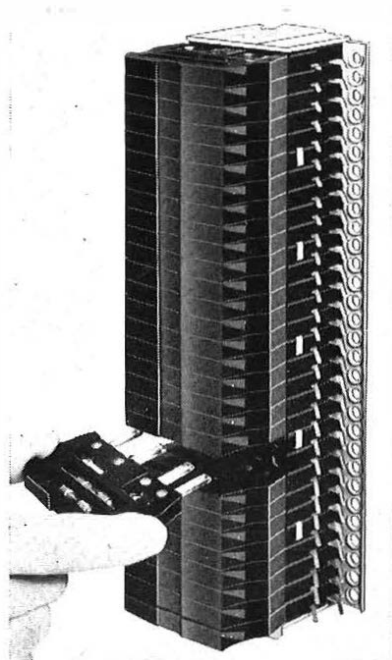

FIG. 1.—FUSE UNIT USED AT SPRINGPARK EXCHANGE

Fuse Unit

The fuse unit fitted on the exchange side of the frame is shown in Fig. 1. It is built up from 30 flat rectangular phenolic mouldings in which the contact springs are loosely laid. The springs are of "U" section at the front ends and are shaped to provide suitable tags for solderless connexion of the internal cabling to the intermediate distribution frame (I.D.F.) and to provide soldering tags for the jumper-wire connexions. The two fuses for an individual subscriber's circuit are mounted in a moulded carrier, and silver-plated contact springs project from the moulding. The unit can be adapted to mount on either side of the frame but, as a consequence of an earlier requirement to provide a design of carrier capable of accommodating fuses large enough to rupture safely at 600 volts, if the unit is used on the line side of the frame the terminating capacity of that side is restricted to 330 pairs per vertical. It was accordingly decided that at Springpark the units should be used on the exchange side of the frame, giving a capacity of 300 circuits per vertical, and that a terminating unit of greater capacity should be provided on the line side.

Line-Side Unit

A simple means of isolating each circuit and of giving access for testing purposes was provided on the line side by a link unit which had been developed by the Automatic Telephone and Electric Co., Ltd., for overseas use. The unit is physically interchangeable with the standard fuse mounting (Fuse Mounting No. 4028), has tin-plated tags for jumper wires on one side of the unit and external wiring terminations and space for silver-plated metallic isolating links on the opposite side.

Result of Experiment

Whilst the items used at Springpark have not been adopted as the future standard, the experiment was useful in demonstrating that the increased concentration of jumper wires that will occur on a more compact frame could in fact be accommodated, and the experience gained has materially assisted in the subsequent development work.

NEW DESIGN OF M.D.F.

The following considerations have largely determined the design of the new frame:

(a) A terminating capacity for at least 400 external cable pairs per vertical is desirable on the line side.

(b) The frame should be suitable for installation in existing buildings and in buildings planned to present standards as regards cable chambers and trenches.

(c) Special footings should not be required, i.e. the ironwork should be suitable for floor fixing in a

similar manner to standard exchange-type racks.

(d) The frame should be suitable for installation, in an apparatus room, parallel to suites of 10 ft 6½ in. high apparatus racks.

(e) Convenient test access should be provided on both sides of the frame and should enable exchange-transfer arrangements to be made in a simple manner.

The new frame (Fig. 2), which is sometimes referred to as the Rack M.D.F., has a terminating capacity of 400 circuits per vertical on each side of the frame, the verticals being spaced 6¾ in. apart. Fuse units and connexion strips, together with jumper rings and the horizontal jumper field, are accommodated on the line side of the frame, whilst the exchange side is fitted with interception jacks and connexion strips. Connexion strips will normally be used for junction terminations on the exchange side and, as a result, 600 such circuits may be accommodated on each vertical equipped in this way.

Whereas a complete vertical on the old frame included

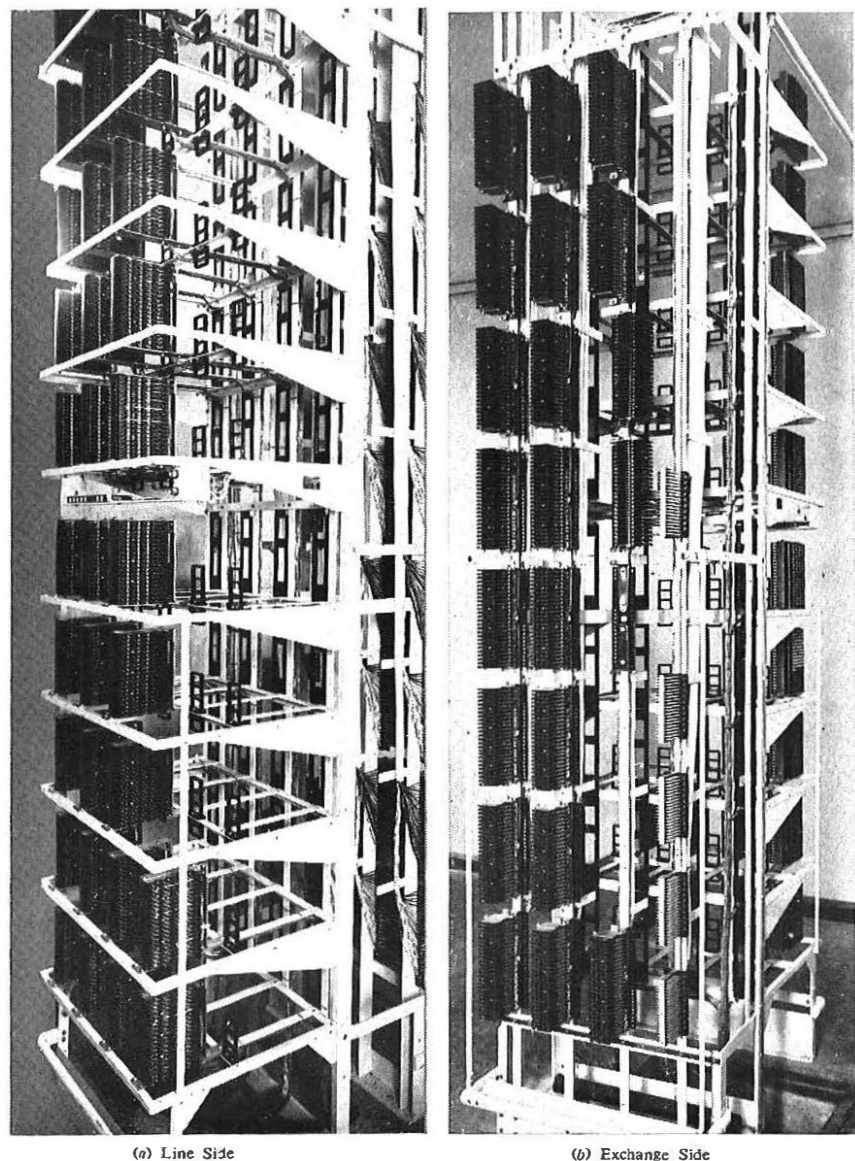
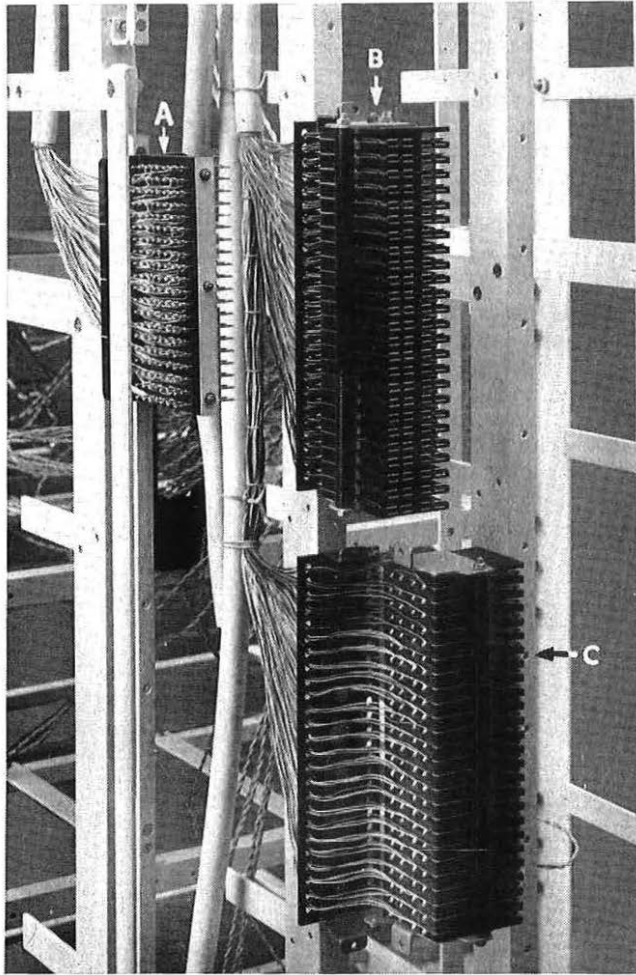

FIG. 2—1,600-LINE UNIT FRAME



A—connexion strip; B—test-jack unit; C—test-jack unit swung outwards to facilitate access to permanent-wiring tags

FIG. 3—TEST JACKS AND CONNEXION STRIPS ON EXCHANGE SIDE

both line-side and exchange-side components, the new design has separate line-side and exchange-side ironwork units each consisting of four verticals. These units or racks are of standard height (10 ft 6½ in.) but are only 2 ft 3 in. in length. A minimum terminating capacity for 1,600 circuits per rack is provided. The line-side rack is divided into ten horizontal jumpering shelves, and four fuse units are fitted on each shelf. The exchange-side rack is a simple structure provided with drillings suitable for mounting columns of interception jacks, connexion strips or both. Normally, eight 50-circuit test jacks (Jacks, Test, No. 33/IA) will be mounted on each vertical, but connexion strips may be used instead as desired, e.g. for junction-cable terminations (Fig. 3).

Although the line-side and exchange-side racks are separate, they are intended for installation back-to-back and, when braced together, form a stable structure. Line-side racks may be installed in advance of the exchange-side racks to facilitate cable terminating, but they will then need to be temporarily supported prior to the installation of the exchange-side racks. The racks will normally be mounted so that there is an overall distance of 3 ft 6 in. between the two guard rails. This distance has been dictated by the need to conform to standard apparatus-rack spacings so that the frame may be mounted parallel to apparatus racks if required.

Fuse Unit

The fuse unit adopted (Fig. 4) has a capacity for 80 fuses. The unit is relatively narrow (2 in.) and, since the mounting centres are 6½ in. apart, hand access to both sides is reasonably provided for. The fuses are mounted on the left-hand side, as seen from the front, and the permanent-wiring and jumper-wire tags are situated on the opposite side. The 40-circuit unit is built up from 20 individual 2-circuit assemblies, which are interlocked by moulded dowels and clamped by two long bolts. Any individual assembly can be removed after slackening the nuts on the two bolts. Fanning holes for both permanent wiring and jumper wires are provided by extensions at the rear of the mouldings.

Individual assemblies comprise two flat plates with recesses for accommodating contact springs. The plates are riveted together and clamp the separate pairs of contact springs over approximately 1 in. of their length. The lower contact springs are of heavier gauge material than the upper flexible springs, and a combined pressure of the order of 300 grammes on the fuse blade is given. Independent twin-contact action occurs as the two springs are united at the wiring point on the opposite side as well as being clamped over their length. The springs are of nickel-silver and, with the use of silver-plated fuse blades, it is expected that reliable contacts will result. Nylon-filled black bakelite is used for the mouldings and an adequate margin of strength and insulation resistance is provided. Recesses are provided in the mouldings between the wiring tags to house the permanent wiring, which is thus protected from damage during jumpering operations.

Exchange-Side Unit

Local distribution-cable pairs will normally be jumpered from the line side to interception jacks on the exchange side. The interception jacks have the simple function of giving access for test purposes to external plant and internal equipment. Interceptions at these points are usually infrequent, however, and circuits may remain uninterrupted for years. Reliable contacts are essential, and single silver contacts have been provided on nickel-silver springs tensioned to pressures high enough to ensure reliability. Test-plugs, which may be inserted into the front of the unit, engage with the nickel-silver surfaces and do not touch the silver contacts. The jumper-wire tags are provided on the right-hand side of the unit, but the permanent-wiring tags are at the rear of the unit. These tags have been designed with a view to their use for solderless connexions by means of wire wrapping and, as such, have sharp edges. The unit is mounted in such a way that it may be swung outwards so that it is possible to wire these tags from the side and yet have them away from possible contact with hands during jumpering operations.

The assembly is built up of two-circuit units in a similar manner to that employed on the fuse mounting. A separate nylon-moulded fanning-strip can be fitted behind the unit on to a vertical mounting bar.

Jumpering

Although the M.D.F. is a useful testing point, its primary function is to provide flexibility between the external cables and internal equipment, and the success of any design is largely dependent upon the ease with which jumpering operations can be carried out. At first sight it would appear that, with an increased terminating

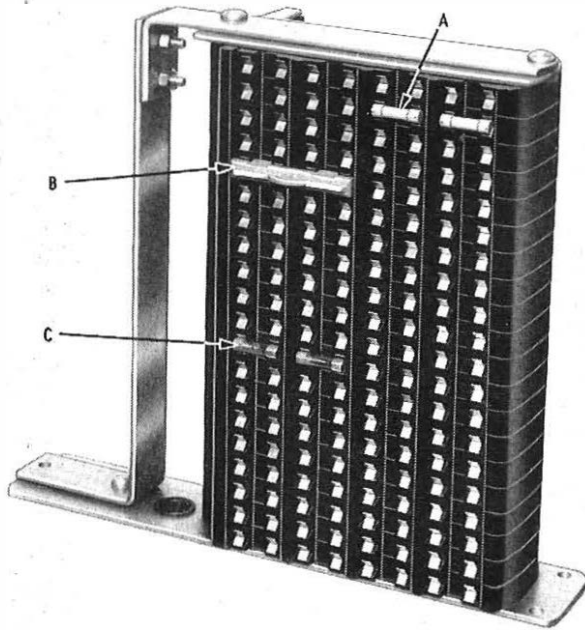

(a) Left-Hand Side showing Dummy Fuses (A), Fuse Covers (B), and Fuses (C)

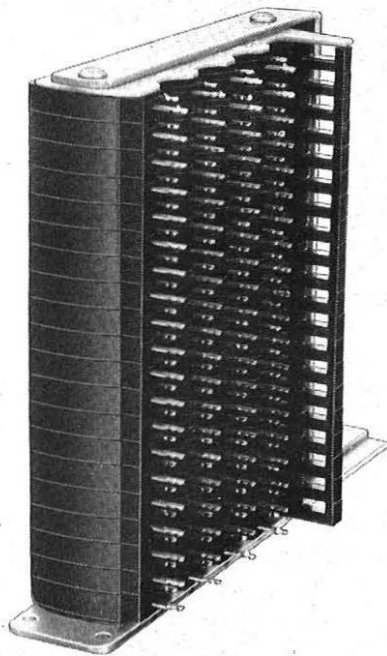

(b) Right-Hand Side
FIG. 4—FUZE UNIT

capacity and reduced overall width, the concentration of jumper wires could result in some degree of congestion. Experience at Springpark exchange has shown however that, using the present standard $9\frac{1}{2}$ lb/mile jumper wire with its close insulation coverings, a terminating capacity of 440 circuits per vertical on the line side and 300 on the exchange side on the old-type framework causes no jumpering difficulty. On the exchange side of the new

frame the jumpering space is virtually unchanged and, despite the increase in capacity, jumpering in this field should be quite satisfactory. On the side of the frame on which the jumper wires run horizontally the width of the jumper-wire bed has been considerably reduced. However, two important causes of congestion in the past have been the difficulty in recovering jumper wires no longer required and the obstruction caused by short jumper wires crossing at right angles to the normal flow. The new frame incorporates arrangements to enable jumper wires run directly between the back-to-back units to be routed in separate rings underneath the horizontal jumpering fields. It is hoped that the reduction in diameter of jumper wire and in overall frame length, with consequent simplification of recoveries, will further assist in ensuring that there is sufficient space for all horizontal jumper wires.

Jumper-wire rings of black nylon are being provided on the initial supplies of the new frame and if found satisfactory will be adopted as standard. The rings are supplied as part of the line-side unit and are provided in pairs immediately behind each fuse unit. A three-hole ring above the shelf enables three-level access to the horizontal jumper field to be given for jumper wires terminating some distance along the frame, whilst a smaller single-hole ring is provided immediately below the shelf to hold the jumper wires serving the units opposite. Two-hole nylon plates are fitted at the rear of the horizontal shelves with a small upper hole for the "within-unit" jumper wires and a larger lower hole for jumper wires entering from the horizontal field. A degree of resilience combined with strength and a low frictional resistance are obtained by the use of nylon for the rings.

Installation

Whilst the design and dimensions of the ironwork are such that the frame can be installed over a cable chamber and served by pipes through the floor in the conventional manner, a modification to the standard design of cable trench is necessary if it is desired to install the frame alongside such a trench. It is practicable with smaller installations to use a trench of reduced length and to feed the cables through a common hole or slot in the floor at the end of the frame and lay the cables underneath the horizontal jumper field. This arrangement, which will be used on the field-trial installation, will be of particular value should it be decided to terminate street cables directly upon the frame. With such an arrangement the facility of installing the line-side rack in advance will assist in forming out and terminating the cables. Protective dust-covers may be provided behind the guard rails partially to enclose such cables.

The external-cable pairs are distributed in blocks of 40 to each fuse mounting via the underside of the jumper field and a bushed hole in the base of the mounting plate. The fuse mounting has a single-hole fixing at the rear and can pivot about this point to give improved access to the permanent-wiring tags; these tags are appreciably shorter than the jumper-wire tags, and without the movement of the fuse mounting some wiring difficulty could be experienced.

Miscellaneous Facilities

As the standard fuse for subscribers' circuits has a rated current of 200 mA it cannot be employed safely on pairs used for such purposes as ringing and power leads. Circuits not exposed to any danger from power contacts

or lightning, e.g. underground junctions, do not need any fuse. On all such circuits, dummy fuses will be used, and a design of fuse dummy has been produced consisting of a silver-plated metal link with an insulated body which gives to it the same size and shape as the standard fuse (see Fig. 4 (a)).

Covers have been provided to fit over the pair of fuses or dummy fuses for each circuit (see Fig. 4 (a)), and it is for this reason that the dummy fuse used is required to be of the same size as the fuse. These covers are made of red polystyrene and will be used on high-grade circuits to act as physical protection as well as markers to guard against inadvertent circuit interruption.

The fuses and fuse dummies are sufficiently small to present some difficulty to people with large fingers, particularly when it is desired to withdraw a fuse or dummy. Furthermore, there is always a possibility of the presence of a mains voltage when a fuse has ruptured and requires changing; it is intended therefore that fuses should not be withdrawn by hand but that a special tool should be used. A simple form of "sugar tongs" made from black nylon has been produced and it is expected that this will be cheap enough to permit a generous distribution for general use.

Special test-plugs have been introduced for obtaining access to circuits on both line and exchange sides of the frame. Advantage has been taken of the small size of the new fuse (Fuse No. 64) to introduce two of these items into the line test-plug, and thus protection of exchange equipment will be provided when a circuit is on test.

EXTENSIONS OF EXISTING M.D.F.S

The new fuse and interception units are unsuitable for mounting on the old standard M.D.F. ironwork and cannot therefore be used where it is desired to extend an existing frame. The new fuse mounting can, however, be

adapted by the fitting of alternative mounting brackets of a form suitable for fitting on the line side of the existing type of frame to give a terminating capacity of 440 lines per vertical. The new 50-way interception unit cannot readily be adapted to mount on the exchange side of the present M.D.F., and accordingly a new 40-way interception unit, which is physically interchangeable with the present type of protector unit, has been introduced for use on the exchange side of existing frames. The springs on this unit are similar to those used on the protector unit, thus enabling the existing type of test-plugs to be used on the new units.

The new standard of protection cannot be introduced piecemeal into an exchange, and if it is desired, on an extension, to increase the capacity of an existing frame in the manner described above, it is first necessary to equip the longer overhead lines with pole-mounted protective units; when this has been done the heat coils and arrestors on the M.D.F. can be replaced by dummies, and fuses on the older type of fuse mountings changed to a delay-action type.

CONCLUSION

A field trial installation is proceeding at Cumnor exchange—a small non-director exchange in the Oxford Area—and the new frame will come into general use on new exchange installations in the early part of 1961.

The new M.D.F. is the result of development work by officers of several Branches and the manufacturers, and although the final design was carried out on behalf of the British Telephone Technical Development Committee by the Automatic Telephone and Electric Co., Ltd., the early development work of Associated Electrical Industries, Ltd., has been of value in bringing to fruition this change from an old-established standard.

Book Review

"Materials and Techniques for Electron Tubes." W. H. Kohl. Reinhold Publishing Corporation, N.Y., Chapman & Hall, Ltd., London. xx + 638 pp. 214 ill. 132s.

This is a much enlarged and completely re-written version of a book originally published in 1951. It is a compendium of information on the behaviour of a number of basic structural materials, and is intended primarily for the designer and manufacturer of electronic valves. However, it will be found exceedingly useful in many other related fields. The original version carried the title "Materials Technology for Electron Tubes," a rather more accurate description of the scope of the book than the new title. The emphasis in most of the book is on materials rather than on manufacturing techniques. There is no discussion of the techniques used in the design of electronic valves.

Electronic valves take many forms but common to them all is an evacuated envelope. This is usually of glass or ceramic, pierced by metal leads to the internal electrodes. It is not surprising therefore that one-quarter of this book is devoted to the properties of various glasses and glass-to-metal seals, with further chapters on ceramics and ceramic-to-metal seals. Two chapters describe the properties and applications of mica and carbon, and seven chapters describe the various metallic elements and alloys which are used in the construction of vacuum devices. The

remaining three chapters are on thermionic cathodes, getters and the joining of metals by brazing.

The book contains a great amount of information, clearly presented. However, in view of the wide scope implied by the new title, there are many omissions, both important and inexplicable. Thus, there is little or no discussion of methods of joining together two metals, other than brazing, or of the techniques for fabricating complex electrode structures, such as conventional or frame grids. The properties of titanium as a structural material are hardly mentioned, and the uses of colloidal suspensions of metals or graphite are dismissed in a few sentences. Insufficient space is devoted to the important problems of the surface cleaning and outgassing of components. Electron emission, as far as this book is concerned, is limited to thermionic emission, as the author does not discuss secondary emission, field emission or any form of gas-filled tube.

American readers will doubtless find the references to suppliers and manufacturers and their trade-names very useful, but the author has not been able to provide an adequate list of British or European equivalents (except where glass is concerned).

Despite this list of criticisms, this work, like its predecessor, is an excellent reference book which will doubtless be used wherever electronic devices are designed and made, either singly in the research laboratory or by mass-production methods in the factory.

H. N. D.

An Introduction to Large Cordless P.A.B.X.s

P. A. MARCHANT, A.M.I.E.E.†

U.D.C. 621.395.25:621.395.65

Cordless-type P.A.B.X.s with less than 50 extensions have been used for many years. Above this size a cord-type switchboard has always been provided with the automatic equipment. The use of a cordless board with these installations is now accepted, and the general aspects of cordless P.A.B.X. working are discussed. The interim designs which have been given approval for immediate use before a standard version is developed are dealt with briefly.

INTRODUCTION

THE term "large cordless," although understood by those familiar with private automatic branch exchange (P.A.B.X.) practice, does perhaps call for explanation. It is customary to define P.A.B.X.s of less than 50 extensions capacity as small P.A.B.X.s and those with 50 or more extensions as large P.A.B.X.s. This is because if the size exceeds 50 extensions a change is made from the packaged or unit-type equipment of limited capacity to extensible equipment, which, for all practical purposes, can be of unlimited capacity.

A manual board, of either cord or cordless type, is an essential part of a P.A.B.X., primarily because incoming exchange calls are connected to extensions by an operator. The essential differences between these two kinds of installation are as follows:

P.A.B.X. with a Cord Manual Board. All telephone traffic that must be passed via the P.A.B.X. operator is connected in a conventional private-manual-branch-exchange (P.M.B.X.) manner using plug-and-cord connexion. The manual board has a manual multiple of extensions and incoming and outgoing circuits. Supervision of calls and release of connexions are controlled by the operator.

P.A.B.X. with a Cordless Manual Board. All manually-controlled traffic is presented automatically to the operator in order of arrival and is routed through the automatic equipment by the operator, using keysending. The operator is concerned only with the setting-up of a call, which, once established, is disconnected from the cordless position. Release of the connexion is automatic.

At present, there are three standard designs of P.A.B.X.s used by the Post Office, and these have been described in an earlier article.* Briefly, the three types are the No. 1, with a cordless manual board and automatic equipment for a maximum of 49 extensions, the No. 2, a similar equipment but with a cord manual board, and the No. 3, again with a cord manual board, for large installations.

HISTORY

At the time of the development of the present standard P.A.B.X.s, about 1950, it was intended to complete the series with a large cordless design. Later, there was some doubt whether such equipment was needed or could compete economically with the No. 3. Although it was considered that cordless working was most desirable in the small size (as has been borne out by events—the

demand for the No. 2 cord type is almost negligible), it did not necessarily follow that the same considerations would apply to the large installations. Faced with a program of the development of more essential types of subscribers' apparatus, it was decided therefore to shelve the project temporarily.

This position was maintained until approximately 1958 when there was considerable demand for cordless installations from customers requiring large P.A.B.X.s. The Post Office had no standard equipment to offer, but fortunately some of the P.A.B.X. manufacturers had already designed and supplied equipment for the export market. These equipments, subject to some rationalization, are now being used to satisfy the immediate demands in the home market.

GENERAL CONSIDERATIONS INFLUENCING THE INTRODUCTION OF CORDLESS INSTALLATIONS

Conditions have changed since the earlier decision was made to shelve the development of large cordless P.A.B.X.s. Although it is still true to-day that such installations have a higher initial cost than those with cord-type manual boards, a much greater emphasis is placed upon the advantages to be obtained from reducing manual operation to a minimum and providing automatic connexion where possible. The reason for the present trend towards cordless working can perhaps best be judged by considering some of the advantages and disadvantages in the light of present-day conditions.

Advantages of Cordless Working

(a) Apart from the connexion of the incoming exchange call, full automatic working can be given with improved facilities and more control from the extension telephone.

(b) Less operating effort is required.

(c) The limitations imposed by the necessity for a manual multiple are removed.

(d) A smaller switchroom is required, representing a saving in expensive accommodation.

(e) Distribution of traffic, particularly the incoming traffic, is more easily controlled and is presented to the operator for connexion in sequence of arrival.

(f) The design of switchboards and the layout of switchrooms can be far less functional and more pleasing in appearance, making the operator's task more congenial and easing staff problems.

Disadvantages of Cordless Working

(a) Increased initial cost of equipment. This may be on average about 25 per cent, but varies considerably according to the requirements of the installation.

(b) More equipment space is required. This is, however, usually the least expensive accommodation.

(c) If full advantage is taken of the reduction in operating force which can be made, a less personal service is given. This may be of importance in some classes of business. Indeed, if a high standard of personal service is to be given then a cordless installation is likely to prove expensive.

† Subscribers' Apparatus and Miscellaneous Services Branch, E.-in-C.'s Office.

* ROCHE, J. J. Post Office Standard P.A.B.X.s. *P.O.E.E.J.*, Vol. 46, p. 159, Jan. 1954 and Vol. 47, pp. 41 and 133, Apr. and Oct. 1954.

PRESENT AND FUTURE DEVELOPMENT

The development of a Post Office standard design of a large cordless P.A.B.X. is now proceeding in co-operation with the telephone manufacturers, through the medium of the British Telephone Technical Development Committee. A considerable amount of work has to be done before this development will be complete, and it is unlikely that equipment will be available for service until 1962. Standardization is being limited, as with the P.A.B.X. No. 3, to circuits, components and facilities.

Until the standard design is available, the manufacturers' own designs are being used. A relatively large number of these installations will be in service by the time the standard P.A.B.X. is available, and they will be identified as P.A.B.X.—A.E.I. No. 4, A.T.E. No. 4, E.T. No. 4, G.E.C. No. 4 and S.T.C. No. 4.† Post Office standard components are used for all types and the facilities are very similar, although the method of providing a facility may vary in detail.

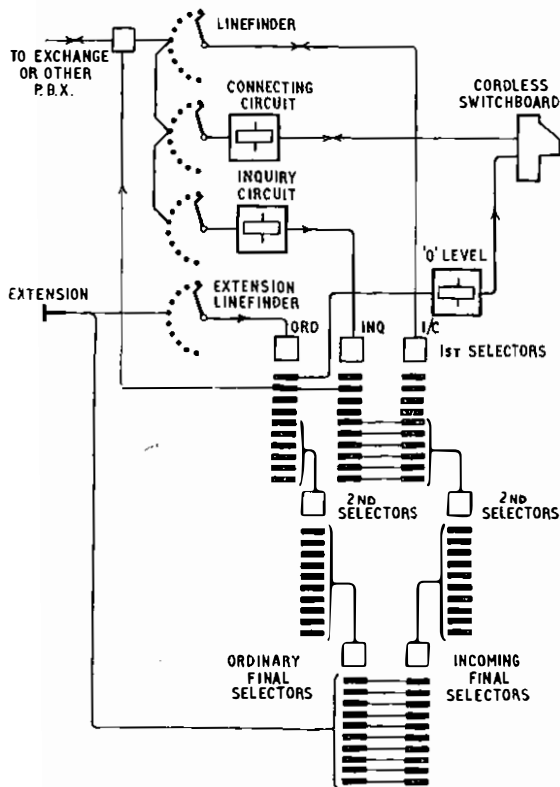

FIG. 1.—SIMPLIFIED TRUNKING DIAGRAM OF A CORDLESS P.A.B.X.

PRINCIPLES OF CORDLESS P.A.B.X. WORKING

It is only possible in a short article to deal with the more important aspects, mainly the differences between the present standard P.A.B.X. No. 3 and the cordless type. Fig. 1 shows a much-simplified typical trunking diagram of a cordless installation.

Extension-to-extension calls and other directly-dialled calls are connected in a similar manner to that used in the standard P.A.B.X. No. 3 and do not call for comment. The main differences in design concern the cordless

† A.E.I.—Associated Electrical Industries, Ltd.; A.T.E.—Automatic Telephone & Electric Co., Ltd.; E.T.—Ericsson Telephones, Ltd.; G.E.C.—General Electric Co., Ltd.; S.T.C.—Standard Telephones & Cables, Ltd.

switchboard and the method of connecting calls by the operator. Also, the inclusion of an automatic inquiry and transfer facility does necessitate some fundamental changes. This facility is important because normally an established call is not supervised by the operator.

Connexion of Incoming Calls

Incoming calls may be operator-connected or dialled direct to extensions automatically. All incoming exchange calls are operator-connected, as are inter-switchboard circuits which cannot, for any reason, be given dialling facilities. Where dialling is provided the arrangements follow standard P.A.B.X. practice, and only the connexion of a call via the operator will be briefly explained.

A signal is given on all the cordless positions when an incoming call arrives. Each position is provided with a maximum of eight connecting circuits, and the operator who accepts the call selects a connecting circuit. The finder associated with this connecting circuit finds the circuit calling and connects it to the operator. To connect the call to an extension the operator will operate the appropriate key and cause the incoming linefinder to find the calling circuit, connecting also the associated 1st selector. At this stage, two separate paths are maintained, one incoming from the calling circuit to the position circuit and the other outgoing from the position circuit to a 1st selector. It is over this second path that the key sender will send the required pulses, setting up the switch train in response to the operator's keying of the extension number. The call remains connected via the position until the called extension answers. The connecting circuit is then released for further use and the incoming circuit is connected directly to the 1st selector.

Should a called extension be engaged, then, if the caller decides to wait, the connexion will be put automatically into the "ring when free" condition when the operator withdraws from the circuit. Again, the position equipment is released when the call is ultimately established, but while in the "ring when free" condition it remains under the supervision of the operator.

It will be noticed from Fig. 1 that there are two separate dialling routes to an extension. The incoming route, which is used for all outside calls, and the local or ordinary route for extension-to-extension calls. This is because the final selectors which deal with traffic over the incoming route have to provide facilities which are not required on the simple extension-to-extension call and it is generally economical to split them into two groups. It is, however, to some extent a matter of design, and combined final selectors are sometimes used in a common group.

In all circumstances the indication of an incoming call at the cordless position must show the class of call, i.e. whether it is an exchange, inter-switchboard or 0-level call, etc. Common answering may be provided, which means that the next call waiting, whatever its class, is accepted by the operator. Alternatively, selective answering can be given whereby an operator can select the class of call to be answered. Selective answering enables priority to be given to certain types of call, but is particularly valuable for large installations where the operators may be divided into groups, dealing with certain classes of traffic.

Connexion of Outgoing Calls

Outgoing calls, with minor exceptions, can be made automatically by the extensions. This is the ideal

arrangement if maximum advantage is to be obtained from a P.A.B.X. This is particularly so for cordless exchanges, because traffic routed via the cordless position uses expensive equipment and the minimum provision of this equipment should be the aim. Unfortunately, this ideal is rarely obtained in practice, primarily because freedom of access to the outside network for all extensions is not always permissible from the customer's viewpoint.

Where the outgoing traffic can be dealt with automatically the arrangements follow normal practice. If a call is to be connected via the manual position then 0 is dialled. The operator accepts the demand over the 0-level circuit and connexion is made by reversion of the call over the manual-board selector train to the extension concerned. When established, the connexion is identical to that for an incoming call.

Selection of an outgoing route by the operator is made by operating the required route-selection key, but on installations with a large number of routes, selection is made by keying one or two code digits.

Automatic Inquiry and Transfer

On private branch exchanges it is often necessary for the user of an extension to make an inquiry of another extension while already engaged on an exchange call. This is known as the inquiry facility and is available on the standard P.A.B.X. No. 3, but transfer of the call is not possible without the intervention of the P.A.B.X. operator. It is obviously of advantage to complete this transfer automatically and it is possible to do this on a cordless P.A.B.X.

An inquiry call is initiated by depressing the recall button on the extension telephone. This causes the circuit to divide at the terminating relay-set, holding the established call and providing a route through the inquiry circuit to the inquiry 1st selector. The required extension can then be dialled. If the call is to be trans-

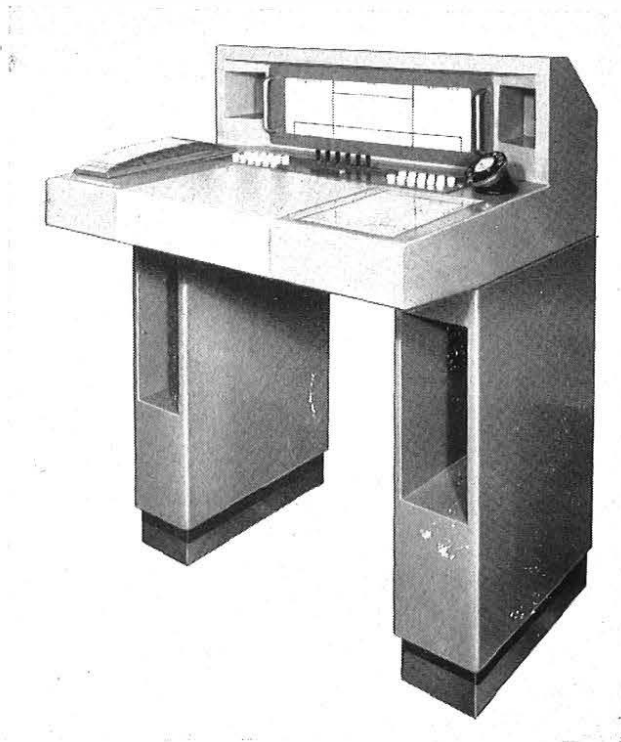

FIG. 3—S.T.C. NO. 4 CORDLESS SWITCHBOARD

ferred, the original switching train is released but the incoming 1st selector is used as a linefinder and is repositioned to the point on the bank multiple at which the inquiry selector is standing. The switching train set up through the inquiry selector is thus held, and transfer of the connexion is made to the second extension. The inquiry selector is then released for further use.

Another method employed on two of the present designs does not use an inquiry selector. The inquiry call is set up over a free incoming linefinder and 1st selector. On transfer, the linefinder used for the inquiry takes up the same position on the bank multiple as the one previously used, and the original switching train is released.

MANUFACTURERS' DESIGNS OF CORDLESS P.A.B.X.

Fig. 2-6 show the various designs of switchboard in current production. They illustrate how advantage can be taken of individual approach to physical design, for which there is scope in this type of apparatus because of the small amount of equipment which has to be provided on the switchboard.

The essential operating controls are similarly placed on all switchboards, but there are variations in detail. The illustrations are of switchboards equipped for particular installations, and even with the same design some changes in layout will be found, according to the size of the installation and facilities required. Further, the switchboards shown are early designs and they may be remodelled as experience is gained. Switchboards may also be specially designed to meet individual requirements.

All switchboards have the common feature of an operating panel and a supervision panel. The operating panel contains the connecting-circuit keys in the centre,

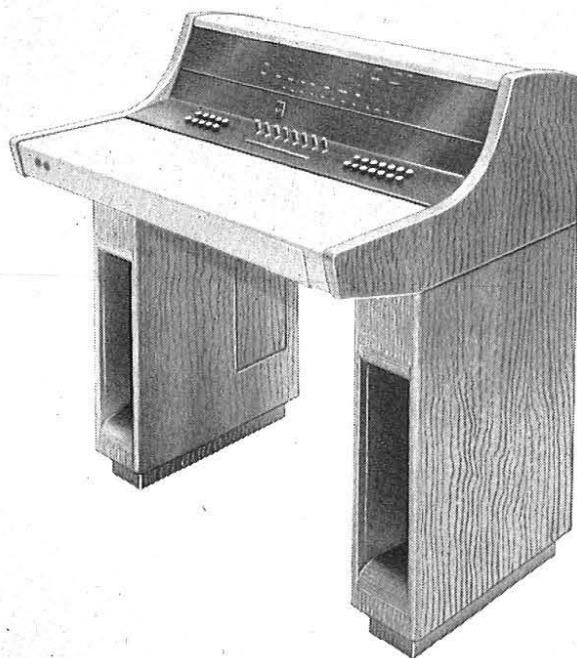

FIG. 2—A.E.I. NO. 4 CORDLESS SWITCHBOARD

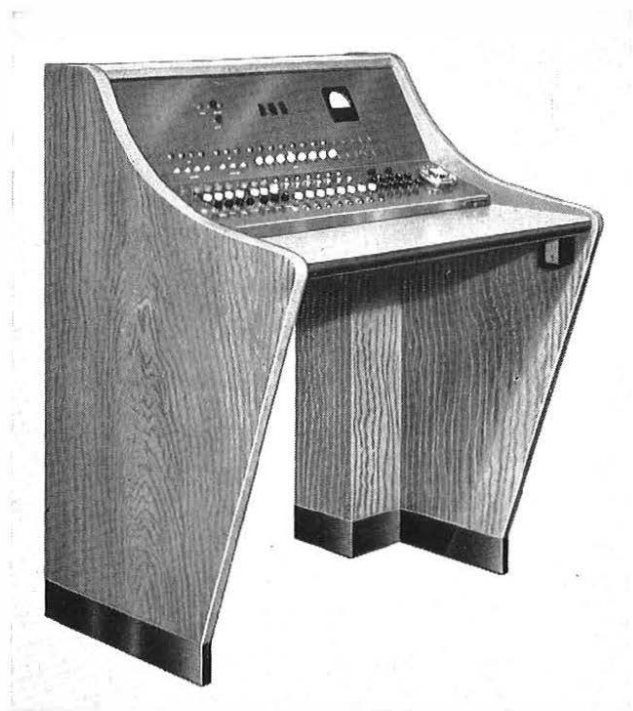

FIG. 4—E.T. NO. 4 CORDLESS SWITCHBOARD

with the keysender on the right and common-control keys on the left. The supervision panel contains supervisory, circuit-identification and other essential information which has to be displayed. The individual connecting-circuit supervision and incoming-call lamps may be on the supervision panel or the operating panel according to the design.

P.A.B.X.s A.E.I. No. 4 and S.T.C. No. 4

The A.E.I. and S.T.C. switchboards (Fig. 2 and 3) have common features in that the supervision panel is in the form of a display, illuminated as required. All supervision is given on this panel. This has the advantage that the actual designation of the signal can be illuminated, but this is necessary in any event because the supervisory indication may be somewhat remote from the key to which it refers. Both switchboards shown are equipped for common answering, a common answer bar being provided in front of the connecting-circuit keys. The automatic equipment in both exchanges is similar to that previously outlined, using inquiry selectors and separate final selectors.

P.A.B.X.s A.T.E. No. 4, E.T. No. 4 and G.E.C. No. 4

Individual lamp supervision is given on the E.T., A.T.E., and G.E.C. switchboards (Fig. 4, 5 and 6). The E.T. No. 4 switchboard uses press-type keys throughout. All the switchboards shown have selective answering. The automatic equipment is again similar to that previously outlined, but inquiry selectors are not used. Also, the A.T.E. No. 4 P.A.B.X. has separate final selectors, whereas the E.T. No. 4 and G.E.C. No. 4 use common final selectors.

CONCLUSION

The cordless type of P.A.B.X. represents the nearest approach to completely automatic working which can be

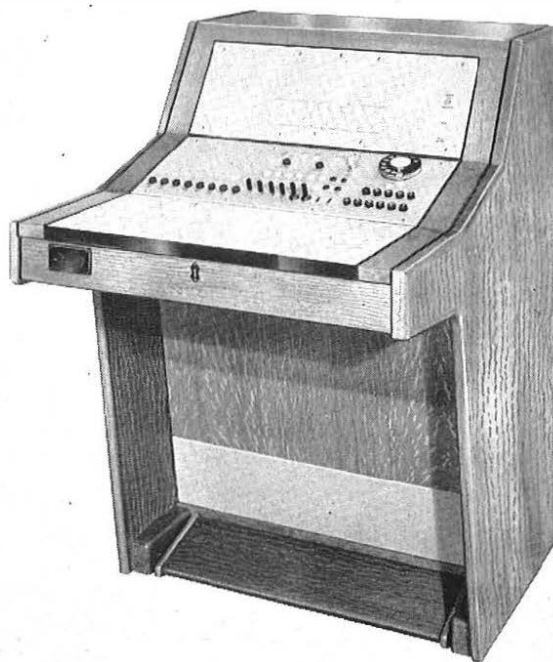

FIG. 5—A.T.E. NO. 4 CORDLESS SWITCHBOARD

made at present. Whether the full advantages of this can be obtained depends to a large extent upon acceptance by the customer of the implications of reducing operator control to the minimum. With the advent of subscriber trunk dialling it becomes more desirable to have freedom of access from the extension point, and the addition of local metering and equipment to bar certain classes of call may go a long way to satisfying the cus-

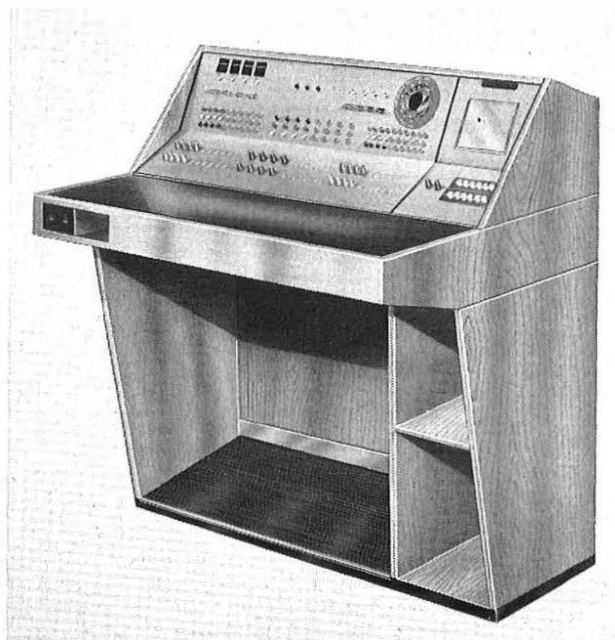

FIG. 6—G.E.C. NO. 4 CORDLESS SWITCHBOARD

tomers that calls can be controlled and accounted for without the intervention of an operator. Both these facilities will be available on the P.A.B.X. Automatic call-accounting would seem an almost complete answer. An installation with this facility is in hand, but unless costs can be reduced it is unlikely to provide the general answer.

It may well be that main exchange equipment of the future will allow for direct dialling into extensions on a P.A.B.X., dispensing almost entirely with the services of an operator. Only cordless installations already contain the equipment to enable this to be done should it become practicable.

There is little doubt that there is a strong demand for cordless installations. Although they are in the early stages of development, more than 50 per cent of the orders for installations for 1959-60 were of the cordless type. Complete supersession of the cord P.A.B.X. No. 3 is, however, unlikely. It will continue to be available where it can be used to advantage.

ACKNOWLEDGEMENT

The co-operation of the P.A.B.X. manufacturers in the preparation of this article is appreciated.

I.E.E. Conference on Electronic Telephone Exchanges

U.D.C. 061.3:621.395.345:621.395.722

THE British Post Office and Industry have a model 100-channel time-division-multiplex electronic telephone exchange working in the Dollis Hill laboratories, and a similar exchange at Highgate Wood is to be put into public service as soon as possible. The U.S.A. announced some time ago that they intended to install a space-division exchange using gas-discharge tubes at Morris, Illinois, and other space-division and time-division systems are known to be under development in various parts of the world. It therefore seemed an appropriate time for the Institution of Electrical Engineers to take the initiative in organizing a Conference on Electronic Telephone Exchanges. Two days of papers and discussions on 22 and 23 November 1960 were followed on the third day by visits by more than 200 participants of the conference to the model exchange at Dollis Hill.

Sir Hamish MacLaren, K.B.E., C.B., the President of the Institution, presided at the opening ceremony and welcomed the participants to the conference. The opening address was given by Mr. A. H. Mumford, the Post Office Engineer-in-Chief, who presented a broad picture of the problems of electronic exchanges and gave a brief historical review of the progress made.

The three sessions of the first day were devoted to time-division-multiplex exchanges. The first two dealt with systems in general, with papers by authors from the United Kingdom, Belgium, U.S.A., Japan and Sweden; 2-wire and 4-wire switching systems with analogue transmission were described, and one paper was concerned with a proposal for a system using pulse-code-modulation transmission. In the third session the Highgate Wood

system was described in detail in 14 papers and contributions.

Space-division systems occupied the first two sessions on the second day, with papers from the United Kingdom, U.S.A., Germany, Holland, Japan and Sweden. Systems using gas tubes, *p-n-p-n* diodes and triodes, and reed relays for switching the speech circuits were described. The conference ended with a general session at which the problems of transmission between exchanges, of telephones suited to electronic exchanges, of the organization of electronic exchanges, and of the use of a digital computer in traffic studies were dealt with in papers presented by authors from the U.S.A., Belgium and Japan as well as from the United Kingdom.

The international interest in the subject can be gauged from the fact that of a total of 38 papers and written contributions, 14 came from overseas. A strong impression is that many kinds of electronic exchange are being investigated throughout the world and it is too soon yet to say which will ultimately survive as commercial systems able to compete with existing electromechanical types. Also it appears now to be fully realized that the problem of electronic exchanges can not be taken in isolation but must be related to telephone networks as a whole, including the planning and economics of the transmission lines between them.

The conference was the first opportunity which the many workers in the electronic exchange field have had to make their respective points of view known in a comprehensive way and proved most valuable not only in the conference room but also in the personal contacts, social occasions and informal discussions which a gathering of this kind makes possible.

T. H. F.

Assessment of Transistor Life

J. C. HENDERSON, B.Sc.†

U.D.C. 621.382.3:620.169

When a new electrical device or component is introduced, equipment designers require some indication of its possible reliability under different operating conditions. This article discusses accelerated aging tests carried out on germanium-type transistors, and the interpretation of the data obtained during these tests. It is expected that silicon transistors will prove to be more reliable than germanium under adverse ambient conditions.

LIST OF SYMBOLS

h_{fe}	= Common-emitter current gain.
I_b	= Base current.
I_c	= Collector current.
I_{CBO}	= Collector-base leakage current.
L	= Median life.
N	= Noise figure.*
T_j	= Junction temperature.
V_{BE}	= Base-emitter voltage under specified circuit conditions.
V_{CB}	= Collector-base voltage.
V_{CE}	= Collector-emitter voltage.
V_L	= "Lower-softening voltage," defined as the minimum value of V_{CE} under specified circuit conditions.
V_U	= "Upper-softening voltage," defined as the maximum value of V_{CE} under specified circuit conditions.

INTRODUCTION

WHEN contemplating the use of any new electrical component, equipment designers naturally require some indication of its possible reliability. In this context, "reliability" comprises the ability to withstand some or all of the following conditions without changing the significant electrical parameters by more than a known small factor beyond their initially acceptable limits:

- (a) Mechanical shock and vibration.
- (b) Extremes of ambient temperature.
- (c) High humidity.
- (d) Current and voltage surges.
- (e) Continuous operation at full rating.

The degree of exposure to each of these conditions may vary greatly depending on the equipment concerned and its sphere of use. For instance, military applications always lead to the emphasis of (a), (b) and (c), but increasing weight is being given to (e).

The devising of economical tests and sampling procedures to give, under each of these five conditions, an acceptable assurance of reliability for thermionic valves, resistors, capacitors and other components has been the subject of work in several government laboratories for many years, and will necessarily continue as new components and devices are brought into production. So far as transistors and related semiconductor devices are concerned, the Post Office and other interested departments have collaborated in producing, with the agreement of the various device manufacturers, a series of CV

† Post Office Research Station.

* Noise figure is defined here as the ratio of the signal/noise ratio at the input to the actual signal/noise ratio at the output of the device under specified circuit conditions.

‡ See, for example, the proceedings of the 5th and 6th National Symposium on Reliability and Quality Control in Electronics, Institute of Radio Engineers, New York, 1959 and 1960.

§ ROBERTS, F. F., HENDERSON, J. C., and HASTIE, R. A. An Accelerated Aging Experiment on Germanium p-n-p Alloy-Type Transistors. *Proceedings I.E.E.*, International Convention on Transistors and Associated Semiconductor Devices, May 1959 (Vol. 106, Part B, Supplement No. 17, p. 958).

specifications: this series commences with CV 7001 and now covers about 100 types of device.

While for most of its applications the Post Office has not been as concerned with items (a) and (b) as the Armed Services have, it has always emphasized (c) as a test condition on account of the high sensitivity of germanium devices, in particular, to the ingress of even small amounts of water vapour. The Post Office has also, from the nature of most of its applications, been especially concerned about item (e), and now, in addition, it is becoming concerned with (d) for some types of device. The remainder of this article will, however, relate primarily to (e), i.e. continuous operation at full rating. Each specification of the CV 7000 series contains a life-test clause which calls for the operation at full rating of a small sample of devices from each delivery lot, for up to 1,000 hours, after which two or three of the basic electrical parameters are permitted to pass outside the initially acceptable limits by 50 per cent.

The duration of this life test, the size of sample, and the permissible change in parameters have been set by practical and economic considerations, the devices concerned being, in the main, used in general service applications. It is recognized, however, that this type of life-test clause provides inadequate safeguard for applications involving either very large numbers of devices operating in single installations (e.g. large electronic computers and switching centres) or small numbers of devices each performing a more critical function and situated in a location not readily accessible for maintenance (e.g. in submerged repeaters). The problems of defining quantitatively what is required by the system and equipment designers, and of devising sampling and test procedures to guarantee the required assurance, are receiving attention in many places.‡ The complementary problems of obtaining significant empirical data on the aging and failure of devices of various structures, and of investigating the physical mechanisms of aging and failure in each type of structure, have been studied by a few of the largest manufacturers and by some users.

ACCELERATED AGING TESTS

The physical mechanisms of aging and failure have been studied at the Post Office Research Station by means of controlled accelerated aging tests on several hundred transistors of one type,§ operated under a carefully chosen range of current, voltage and ambient-temperature conditions, and by the more detailed investigation of individual transistors and their hermetically sealed envelopes under extremes of ambient atmosphere.

The effects of aging on the transistor parameters (other than noise) which have been found most subject to change are shown in Fig. 1. It can be seen that for a constant input signal, the rectangle bounding the usable active region tends to shrink as the transistor ages. However, the unacceptable deterioration of any particular parameter may vary from one application to another. One of the most common causes of failure has been an excessive rise in the collector-base leakage current, I_{CBO} (with a correlated rise in the noise figure, N , and a reduction in the upper-softening voltage, V_U), and this has been almost

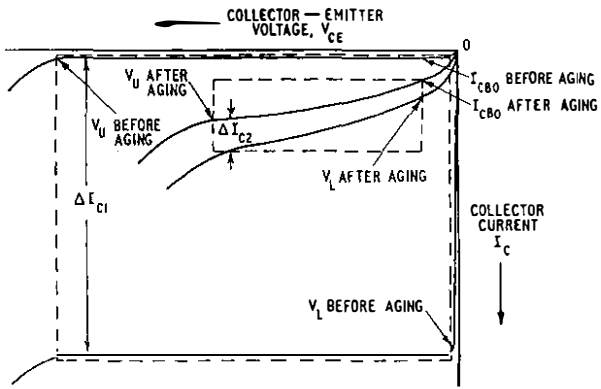

Notes:

1. The usable region of a transistor is bounded by the parameters I_{CBO} , V_U , V_L and $(h_{fe} \times \Delta I_B)$.
2. ΔI_{C1} and ΔI_{C2} correspond to the same input signal ΔI_B applied before and after aging, respectively.

FIG. 1—THE CONTRACTION OF THE USABLE REGION OF A TRANSISTOR DUE TO AGING

the sole reason for diagnosing a failure in these aging tests (see Fig. 2).

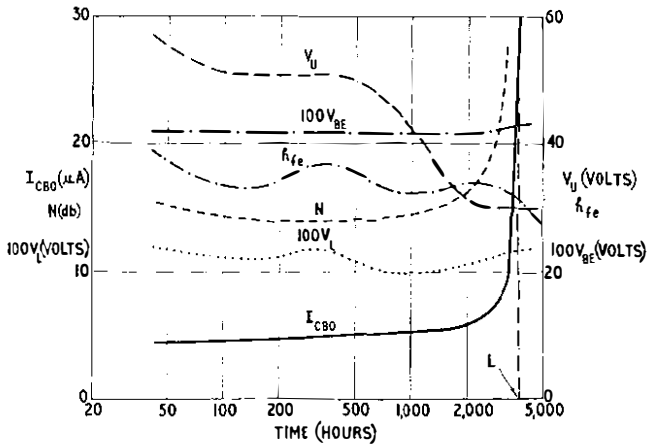

Transistor aged with $T_J = 90^\circ\text{C}$ and $V_{CB} = -4$ volts.

FIG. 2—TYPICAL AGING CHARACTERISTICS OF ONE TYPE OF P-N-P GERMANIUM ALLOY TRANSISTOR MEASURED AT 26°C

The rate of aging was, as expected, most rapid for units aged with the highest junction temperature, T_J , and collector-base voltage, V_{CB} . In fact, the median life, L , as determined by the onset of a rapid increase of I_{CBO} , was found to follow approximately the law

$$L = A \exp\left(\frac{B}{T_J}\right),$$

where A and B are constants, and T_J is in degrees Kelvin. It was also found that B was approximately 15,000 and, thus, L was halved for about each 6°C rise in T_J for temperatures in the region of 80°C . The detailed analysis of results, illustrated in Fig. 3, showed that A and B were functions of V_{CB} ; there was, however, no significant correlation between L and the initial value of I_{CBO} .

The basic assumption underlying the use of accelerated aging conditions is that the law relating life with junction temperature over a limited temperature range (see the line (a) in Fig. 4) remains valid beyond that range. This assumption is equivalent to there being a single thermally-activated mechanism for deterioration. Any further similar mechanisms would be expected to obey similar

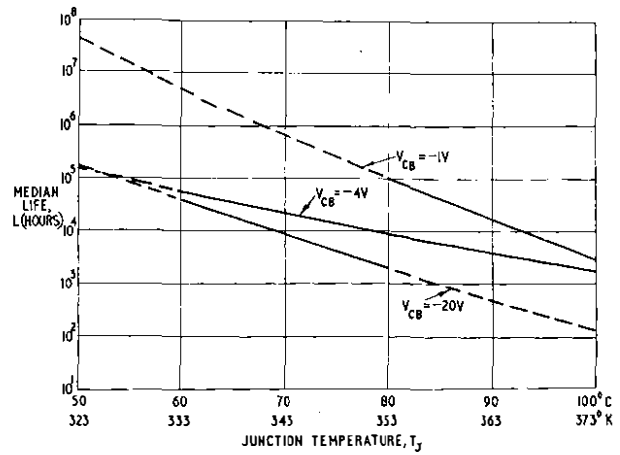

The median life, L , was estimated from I_{CBO} data for about 400 transistors

FIG. 3—ESTIMATE OF MEDIAN LIFE SHOWING DEPENDENCY ON V_{CB} AND T_J DURING AGING

laws, in general with different values of A and B . Two such possible laws are shown by the lines (b) and (c) of Fig. 4.

While the original failure mechanism producing line (a) of Fig. 4 corresponds to failures primarily diagnosed by deterioration of I_{CBO} , the mechanism that could lead to lines (b) or (c) may correspond to failure by deterioration of other parameters. Any thorough investigation of transistor life must include the study of mechanisms likely to cause deterioration of any parameter, even by an amount in itself insufficient to be classified as a failure of the transistor under the aging conditions of the experiment.

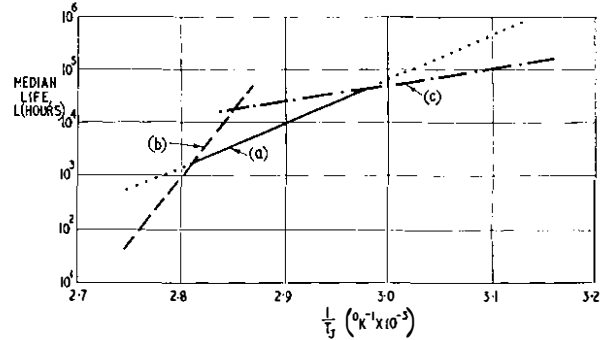

(a) shows law based on experimental evidence of aging of I_{CBO} .

(b) and (c) show possible laws effective for change of other parameters with aging.

FIG. 4—SUPERPOSITION OF THREE LIFE LAWS OF THE FORM $L = A \exp(B/T_J)$

A vital part of this study must be the determination of the time-dependence of each parameter under various aging conditions; for if the time-dependence is known and a life-end point is chosen, a value of L can be determined by extrapolation on the time scale for each parameter, for temperatures in the range of the accelerated aging experiment. A second extrapolation will, in general, then be needed to predict L for temperatures in the user's normal operating range. In this way data for curves such as (b) and (c) in Fig. 4 can, in principle, be obtained.

The failure symptoms which were dominant in the earlier experiments have been simulated in subsidiary experiments on similar transistors without their normal sealing envelopes. Thus, for instance, an immediate and

reversible increase in the noise figure and in I_{CBO} resulted when the ambient water-vapour pressure was increased to a few millimetres of mercury. A long-term effect, thought to be dependent on the migration of indium in the electric field across the edge of the biased collector junction, has also been observed; it appears as the formation of an ohmic leakage path across the junction, the leakage not depending for its maintenance on high humidity but being removed only by re-etching the transistor. Other experimental transistors have exhibited decreases of common-emitter current gain, h_{fe} , as well as increases of I_{CBO} , by large factors, as a result of baking at about 100°C for some hundreds of hours immediately following fabrication—effects almost certainly due to the formation of a surface film (e.g. a contaminated oxide) on the germanium which results in a high recombination rate for holes and electrons. This surface film can be removed by re-etching, but it is commonly used to stabilize the characteristic of many factory-made transistors.

The high sensitivity of the germanium surface to the presence of water vapour makes high-quality hermetic sealing essential, i.e. the rate of leakage into the hermetically sealed envelope, and of the release of water vapour from the walls of the envelope, must be extremely small. These rates are being investigated for several types of sealing envelope in the current work at the Post Office Research Station. A possible future development could be the coating of the active elements of the transistor with glass having a suitable melting point.

Because germanium is so sensitive to adverse ambient conditions, more attention is now being directed towards silicon devices. It is expected that for the following reasons silicon transistors will prove to be more reliable. At the maximum working junction temperature, the I_{CBO} of silicon devices is much lower than that obtained with the germanium equivalents, so a much larger factor of deterioration of I_{CBO} would be acceptable. Higher melting-point materials can be used in the manufacture of silicon devices; thus, a higher final temperature can be used to release the occluded gases in the device and stabilize its characteristics, while higher temperatures can be withstood during transient overloads. Furthermore, since the natural silicon surface always has an oxide layer associated with it, which tends to form a protective coating, the growth of leakage paths may not be such a serious problem.

The above potential advantages of silicon will apply not only to the low-frequency alloy-type transistors, but also to the v.h.f. units (using the mesa structure) which will be required for wideband and fast switching applications.

Life tests on both silicon and germanium units of this type are planned so as to resolve the relative merits of each type. Use will be made of automatic testing and data logging, and analysis by electronic machines will help to reduce the computation time required before useful answers are obtained.

Book Review

“The Theory of Functions of Real Variables” (Two Volumes). James Pierpoint, LL.D. Dover Publications, Inc., N.Y., and Constable & Co., London. Vol. I: xii + 560 pp. 127 ill. 20s. Vol. II: xiii + 645 pp. 13 ill. 20s.

This new paperbound edition of Prof. Pierpoint's authoritative exposition of the theory of functions of real variables will be welcomed by students. There are two volumes in this republication and together they record the highly successful series of lectures Prof. Pierpoint gave at Yale University on advanced calculus and the fundamental concepts of Lebesgue integration and measure theory.

The first volume deals with functional differentiation and integration. Here the theorems, together with all their conditions, are first stated. These statements are then followed by their proofs. In each case there is a careful examination of the conditions of validity. Thus, there is no need for a student to worry about conditions that have not been explicitly mentioned and discussed. This makes the volume easy for the student to read and understand.

The second volume opens with a discussion of the theory of integration resting on the notion of a cell and the division of space into point sets. This is followed by a complete and rigorous presentation of the theory of measure. Measure theory is fast becoming of major importance to those engineers who are studying stochastic processes in modern telecommunication systems. Prof. Pierpoint's discussion of measure theory given in this volume is one of the best that can be found in English.

In this Dover edition Prof. Pierpoint also presents his own original work on the theory of Lebesgue integration and his treatment of surfaces and volumes in hyper-space. Unlike most texts, theorems proceed from the specific to the

general case, rather than the reverse. This method avoids a lot of heavy symbolism and makes the work easier for the student to grasp.

H. J. J.

Book Received

“Examples in Applied Thermodynamics.” J. Phillips, A.M.I.Mech.E. The English Universities Press, Ltd. 223 pp. 135 ill. 17s. 6d.

This book, in The Technical College Series, is intended for the use of students preparing for the subject of Applied Thermodynamics (or Heat Engines) in Ordinary National Certificate courses and the Part I B.Sc.(Eng.) University of London examination in Applied Heat, while candidates for external examinations of the professional engineering institutions may gain assistance from this work. The book is not intended to supersede existing textbook on the subject, but might be looked upon as a companion to the lecturer's notes.

There are 14 chapters covering the following subjects: properties of gases (two chapters), ideal cycles, entropy of gases, heat transmission, flow of gases and vapours, reciprocating air compressors, internal combustion engines, properties of steam, the Rankine cycle and harder examples on steam, steam boilers and condensers, steam engines, and combustion of fuels (two chapters). Each chapter has four sections. A chapter is introduced by an outline of the basic theory, which is followed by a tabulated list of “Points to note.” Next, there follows a number of fully-worked examples, and the chapter concludes with several exercises (the numerical answers are supplied) for the student. Many of the 136 questions for which model answers are provided and the 63 questions set as exercises have been reprinted from examination papers of the University of London and the Institution of Mechanical Engineers.

A Receiver for Direct-Pick-Up Television Links

N. A. ELKINS, D. E. MILLS, B.Sc.(Eng.), A.M.I.E.E., and L. D. W. FENSOME†

U.D.C. 621.397.62:621.397.27

The advantages and disadvantages of direct-pick-up television links are described, together with the performance requirements of the television receiver used, and a description is given of a new receiver for use with such links.

INTRODUCTION

THE design of the television receiver which is to be described was undertaken in order to provide a sensitive receiver of high quality for use in direct-pick-up (d.p.u.) television links. Such a receiver has other applications, of which the provision of "standby" facilities at transmitting stations and propagation measurements are examples.

A d.p.u. television link is one which relies, for part of its length, on the reception of vision signals from a public-service broadcast transmitter, the sound signal being transmitted by cable in the usual way. Such links are relatively cheap to provide, since the length of conventional circuit required is much reduced, but they are susceptible to more forms of degradation than conventional links and, generally, have a lower standard of performance. The performance standards of conventional links, however, are set at a level which permits the tandem connexion of several links without significant deterioration of the signal. Permanent d.p.u. links are used only to feed low-power stations which serve isolated communities or small areas screened from the main transmitters. They are, therefore, rarely connected in tandem so that it is reasonable to allow the performance specification to be less exacting than that of the main links.

The sources of degradation which are peculiar to d.p.u. links include the television broadcasting transmitter, the propagation path, the receiving aerial and the receiver itself. Little can be done in the design of the receiving equipment to offset distortion arising in the broadcasting transmitter and the propagation path, though the contribution of the latter may be minimized by the choice of receiving site. The amount of waveform distortion introduced by resonant receiving aerials is governed by the aerial gain, and may be important if the range is great or if high directivity is needed for other reasons. Distortion originating in an aerial system can sometimes be reduced by the use of equalizers in the receiver.

The distortion arising within the receiver itself is in part due to the need for rejecting the sound signal accompanying the vision transmission. The frequency separation between the sound carrier and the highest vision modulating frequency is 500 kc/s, and it is necessary to obtain adequate attenuation of the sound signal with minimum effect on the frequency and phase response of the vision channel. The action of sound-rejection circuits in the vision band is, generally, to modify the response at the higher modulating frequencies

† Post Office Research Station.

with consequent effect on the fine detail of a picture. Due to the use of the vestigial-sideband system of transmission further distortion¹ is introduced in the receiver; this distortion can be reduced by the choice of response in the region of the carrier frequency, but it cannot be wholly eliminated.

D.P.U. receivers are generally required to work with small input signals, so that a low level of self-generated noise is a necessary performance requirement. As it is not possible to design entirely satisfactory ignition-interference suppression circuits, d.p.u. sites are located in areas which are relatively free from this type of interference.

A good automatic-gain-control (a.g.c.) system is a prime requirement since the propagation path may be long enough for fading to occur, and the response of the a.g.c. system may need to be fast enough to deal with the rapid fading, or flutter, caused by the presence of aircraft in the transmission path.

Other factors which influence the design of d.p.u. receivers are the need for sturdiness of construction, high reliability, good long-term stability due to the inaccessibility of some d.p.u. sites, and the need to use circuits of a type which can be aligned by operators using simple test equipment.

CIRCUIT DESCRIPTION

The block schematic diagram of the receiver (Receiver, Radio, No. 25A) is shown in Fig. 1. The receiver is of the superheterodyne type, with the local-oscillator frequency higher than the signal frequency and an intermediate

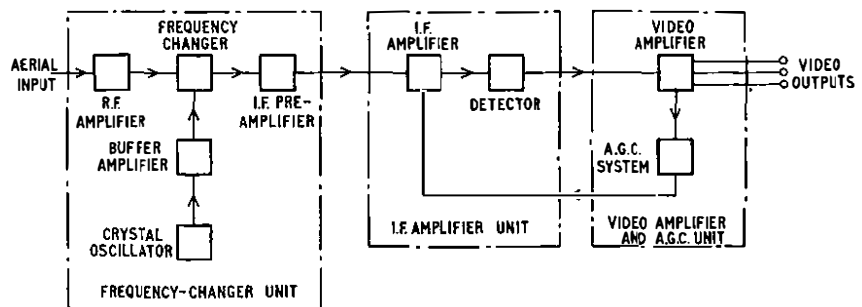

FIG. 1—BLOCK SCHEMATIC DIAGRAM OF RECEIVER, RADIO, NO. 25A

vision carrier frequency of 34.5 Mc/s. Although the receiver is primarily designed for reception of vision signals in Band I (41–68 Mc/s), this value of intermediate frequency (i.f.) was chosen in order that the same i.f. amplifier could be used in receivers designed for reception at higher frequencies, e.g. in Band III (174–216 Mc/s). The possibility of interference is also reduced by using this intermediate frequency.² The synchronizing-pulse amplitude in the video output, being nominally independent of picture content, is used to produce the control voltage for the a.g.c. system.

The complete receiver consists of three separate units: the frequency-changer unit, the i.f. amplifier unit, and

the video-amplifier and a.g.c. unit, and in order to change channels it is necessary only to replace the first of these units.

A 75-ohm termination for the aerial feeder is provided at the input of the receiver by a tuned transformer, which feeds a low-noise "cascode" stage of signal-frequency amplification. This is followed by a triode frequency-changer, with both signal and local-oscillator voltages applied to the control grid. A crystal-controlled local oscillator is employed and its output is fed through a buffer amplifier to the frequency-changer. The signal is changed in frequency so that the intermediate vision carrier frequency is 34.5 Mc/s; two stages of i.f. amplification follow, and the output is fed, at 75-ohm impedance, to the main i.f. amplifier. The overall conversion gain of the frequency-changer unit is approximately 30 db, and the frequency response is substantially flat over the vision band of the particular channel to which the receiver is tuned.

The main i.f. amplifier contains eight stages, and the amplitude/frequency response is of approximately the correct shape for vestigial-sideband operation, with a "flat-topped" characteristic and the response 6 db down at 34.5 Mc/s. Rejection of the accompanying sound carrier at a frequency of 38.0 Mc/s is achieved by the use of two "bifilar-T trap"^{3,4} circuits, which reject a narrow band of frequencies in an otherwise broad pass-band. Each of these circuits is inserted between two of the valve-amplifying stages, and the remaining six stages are arranged as two flat-staggered triples.⁵ Seven of the eight stages use valves with characteristics suitable for the application of variable gain control, and the control grids of these stages are returned to a negative-bias line which can be switched for gain-control purposes to either a manually controlled supply or the output of the a.g.c. unit. The output stage feeds a crystal-diode detector at a sufficiently high level to ensure good amplitude linearity. The video signal is taken through a low-pass filter to the input of the video amplifier, and a facility has been provided to enable relative measurements of average detector current to be made.

The three-stage video amplifier is a distribution amplifier of 4 db gain; the first two stages are voltage amplifiers, the output stage consists of two parallel-fed cathode-followers, and negative feedback is applied

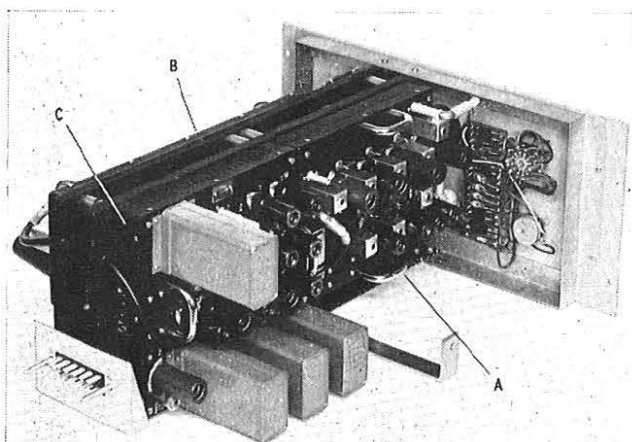

A = Frequency-Changer Unit
B = I.F. Amplifier Unit
C = Video Amplifier and A.G.C. Unit

FIG. 2.—LAYOUT OF FREQUENCY-CHANGER, AND VIDEO AMPLIFIER AND A.G.C. UNITS

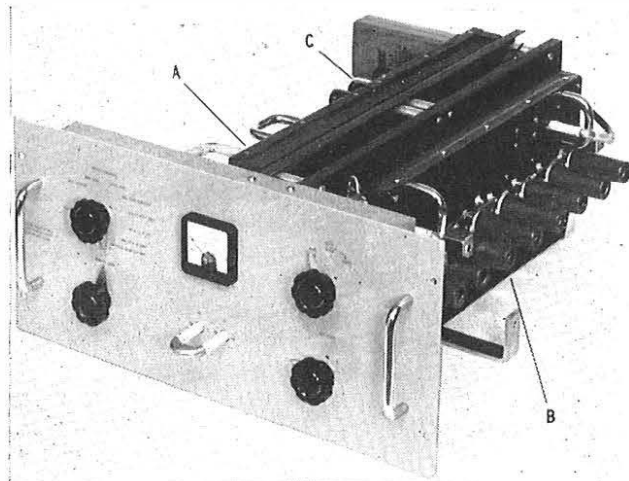

A = Frequency-Changer Unit
B = I.F. Amplifier Unit
C = Video Amplifier and A.G.C. Unit

FIG. 3.—LAYOUT OF I.F. AMPLIFIER UNIT AND FRONT PANEL OF RECEIVER

between the cathode circuits of the first and third stages. The amplifier provides three 75-ohm impedance outputs each at a nominal level of 1 volt peak-to-peak, and the output level at any one of the three outputs is substantially independent of the terminations at the other two. The a.g.c. circuits are fed from the video amplifier, and the video signal is amplified and its black level "clamped" to a fixed potential. This signal is applied to a synchronizing-pulse separator stage which produces pulses whose amplitude depends on the synchronizing-pulse amplitude of the video output; these pulses are rectified to produce a negative d.c. output which is fed as bias to the i.f. amplifier unit, and the value of this bias may be varied by means of a potentiometer which acts as an output-level control. Two time constants are available in the a.g.c. bias circuit; the slower is for normal use, and the faster is for dealing with a very fast flutter of the incoming signal.

The bias line of the i.f. amplifier is fed to an impedance-converter stage, the output of which may be used to operate a recording milliammeter, when the receiver is a.g.c. controlled, for the purpose of obtaining continuous records of bias voltage and, hence, of input level to the receiver.

PHYSICAL DESIGN

D.P.U. stations are often sited in rather inaccessible places, so that reliability and ease of maintenance are important qualities of d.p.u. equipment. One reliability factor that has been given particular attention in the receiver is the need for cool operating conditions, and an arrangement has been chosen which makes good use of natural cooling. The photographs of the receiver (Fig. 2 and 3) show the layout, which encourages the free flow of convected air over the hot surfaces, while a matt black paint improves the heat-radiating properties of these surfaces. Good thermal contacts between the units and the mounting helps the conduction of heat into the cabinet in which the receiver is mounted.

The receiver may be withdrawn from the cabinet on telescopic runners, providing good access for simple maintenance work. The individual units jack-in to the central framework and can easily be removed for more complex repairs.

PERFORMANCE

The noise factor* of the receiver is approximately 6 db.

The a.g.c. characteristics of the receiver are such that the video output level changes by 1 db as the radio-frequency signal input to the receiver increases from +40 db to +80 db relative to one microvolt. For input levels below +40 db relative to one microvolt the output is far too noisy to be of use; for input levels greater than +80 db relative to one microvolt, overloading occurs and the input level must be suitably attenuated.

The overall video-frequency response is flat to within ± 0.5 db from the lowest video frequencies up to a frequency of approximately 2.8 Mc/s; above this frequency the response falls off sharply, and at a frequency of 3 Mc/s the response is approximately 2 db down. The response at the associated sound carrier frequency is at least 54 db below the response at the vision carrier frequency.

In the assessment of the transient response of the receiver, using a suitable rectangular-pulse waveform the rise and fall times do not exceed $0.18 \mu\text{s}$, and overshoots and undershoots do not exceed 10 per cent of the pulse amplitude.

The *K*-rating methods of waveform response assessment,^{6,7} using sine-squared pulse-and-bar test waveforms have been applied to the receiver. These methods are based on subjective distortion effects in a linear system, distortion consisting of a single long-term echo having been adopted as a basis of reference in such a manner that the relative amplitude of this echo is numerically equal to *K*. The results of applying these methods show that they do not directly apply when the non-linearity due to quadrature-component distortion¹ is as high as in a broadcast receiver. Nevertheless, some idea of the

* Noise factor is defined as the ratio of the available signal/noise ratio at the source to the actual signal/noise ratio at the output of the receiver.

performance may be gained from the fact that if it is assumed that the part of the routine-test method employing the *2T* pulse-and-bar waveform is directly applicable and the receiver is aligned for optimum performance using this waveform, a *K*-rating of 2 per cent is achieved.

CONCLUSION

A number of d.p.u. television receivers of the type described have been made and aligned by a contractor, and some of these receivers have been successfully used as sources of good quality television signals for various purposes.

A frequency-changer unit which will enable the receiver to be used for the reception of television signals in Band III is under development, while the receiver has been used with a specially made frequency-changer unit for the reception of experimental transmissions at Band V frequencies (610–960 Mc/s). It therefore seems likely that provision of appropriate frequency-changer units will enable the receiver to meet the d.p.u. requirements for 3 Mc/s band-width monochrome transmissions for some time to come.

References

- ¹ KILVINGTON, T., LAVER, F. J. M., and STANESBY, H. The London-Birmingham Television-Cable System. *Proceedings I.E.E.*, Paper No. 1187, March 1952 (Vol. 99, Part I, p. 52).
- ² Report on Television Receiver Intermediate Frequency. British Radio Equipment Manufacturers' Association. Oct. 1954.
- ³ FISHER, B., and AVINS, J. An Analysis of the Bifilar-T Trap Circuit. (Radio Corporation of America, Application Note).
- ⁴ Editorial, *Wireless Engineer*, Vol. 33, pp. 77 and 105, Apr. and May 1956.
- ⁵ VALLEY, G. E., and WALLMAN, H. Vacuum Tube Amplifiers (McGraw-Hill Book Company, 1948), p. 186.
- ⁶ LEWIS, N. W. Waveform Response of Television Links. *Proceedings I.E.E.*, Paper No. 1688, July 1954 (Vol. 101, Part III, p. 258).
- ⁷ MACDIARMID, I. F. Waveform Distortion in Television Links. *P.O.E.E.J.*, Vol. 52, pp. 108 and 188, July and Oct. 1959.

Book Review

"Applied Electricity." Prof. H. Cotton, M.B.F., D.Sc., M.I.E.E. Cleaver-Hume Press, Ltd. xii + 516 pp. 403 ill. 25s.

This is the fifth edition of a book by an author who is well known to students of electrical engineering. The first edition was published in 1951, since which date the various editions have been very well received by those interested in the subject.

The book is suitable for those studying for Part I of a B.Sc. engineering degree, the Institution of Electrical Engineers' graduate examination, or a National Certificate.

This new edition differs from its predecessors in that it has a much enlarged chapter on electronics, and a section on non-linear resistors and semiconductors. In addition to the large number of questions set on the subject matter of each chapter, together with answers at the end of the book, there are a number of selected worked-out examples within each chapter.

The first five chapters deal with such fundamentals as units, current, magnetism, electrostatics and electrolysis. Three chapters are devoted to d.c. machines and eight chapters to alternating currents, a.c. machines and transformers. In addition to the chapter on electronics there are also chapters on illumination and measuring instruments.

The treatment of the fundamentals in the earlier chapters

is somewhat similar to that in most good-class works of this type and, although it is largely a matter of opinion on what should be inserted in or left out of any particular chapter, here and there some important points appear to have been omitted. For example, in the chapter on conduction in electrolytes, a little more space might have been devoted to the important lead-acid accumulator, and in the references to its efficiencies and internal resistance it would have been useful to have stated the values that could be expected in practice. The chapter on the induction motor, particularly the section on speed control, might well have included some reference to the tandem motor. Again, in the chapter on illumination, the principles and design aspects are adequately covered but there is only brief reference to the metal-filament lamp and no mention of the fluorescent lamp which has been so extensively used for several years in modern lighting. There is, however, a brief note on the starting arrangements for this lamp on page 408 in the chapter on electronics but which is incorrectly shown in the index as page 397. This interesting electronics chapter deals with thermionic valves and their characteristics, arc rectifiers and metal rectifiers, arc-discharge lamps, and some recent information on semiconductors, including germanium and silicon rectifiers, transistors, and thermistors.

The book is well written, the printing and illustrations are both clear, and the material is such that it will be very useful to all electrical-engineering students.

R. S. P.

A Switching Unit for Use with 700-Type Telephones—Plan Set N625

K. M. AKESTER, B.Sc.(Eng.), A.M.I.E.E.†

U.D.C. 621.395.65:621.395.721.1

A switching unit has been developed to permit the use of 700-type telephones on extension plans with intercommunication (Plans 5 and 7). The unit, designated Plan Set N 625, and the associated apparatus are described and the advantages over existing apparatus are pointed out.

INTRODUCTION

EXTENSION plans consisting of one exchange line and two or three telephones with intercommunication have been popular with customers for over 50 years. An installation with one main and one extension telephone is known as a Plan 7: an installation with one main and two extension telephones is called a Plan 5. Such installations require a switching unit, and this was originally incorporated in a wall-mounting bell set used at the main station. The introduction of handset telephones was followed by the development of the Bell Set No. 39¹, which formed the basis of the improved Bell Set No. 44. These were switching units intended to stand on a desk and have a special handset telephone, Telephone No. 248, mounted on top of them. Although the title "bell set" was retained, these items did not contain bells.

Because Bell Sets No. 39 and 44 are intended for use only with Telephones No. 248, it is not possible to fit 700-type telephones at the main stations of Plan 5 and 7 installations. Pending the development of a replacement for these bell sets the use of the Telephone No. 706 was permitted at extensions only.

The desirability of using the Telephone No. 706 to meet as many requirements as possible has been discussed elsewhere.² A new switching unit has therefore been developed as a plinth on which a Telephone No. 706 can be mounted. The objectives in designing the switching unit were that it should:

- (a) be of modern appearance and in harmony with Telephone No. 706,
- (b) provide all the facilities given by existing Plans 5 and 7 and, in addition, enable external extensions to be used with Plan 5, as well as with Plan 7,
- (c) operate with extension-to-exchange lines of 1,000 ohms resistance,
- (d) have press-buttons instead of the rotary switch used in the Bell Set No. 44,
- (e) have a lamp to indicate when an extension-to-exchange call is in progress instead of the 3,000-type relay indicator used in the Bell Set No. 44,
- (f) dispense with hand generators, and
- (g) operate from a.c. mains or batteries.

PLAN SET N 625

The new switching unit has been designated Plan Set N 625 and meets the requirements listed above. The title was chosen to indicate an association with extension plans and to avoid the misleading term "bell set" as well as the very general term "switching unit." N 625 is the number of the circuit diagram of the plan set.

The plan set, the appearance of which has been approved by the Council of Industrial Design, is shown

† Subscribers' Apparatus and Miscellaneous Services Branch, E.-in-C.'s Office.



FIG. 1—PLAN SET N 625 AND TELEPHONE NO. 705

in Fig. 1 together with a Telephone No. 706. The moulding material, polymethyl methacrylate, is that used for the Telephone No. 706 and is suitable for production in the full colour range used for that telephone, although at present it is intended to produce plan sets in elephant grey only. The plan set is supplied with an 18-way cord and a terminal block and also with a short 13-way cord which connects the plan set to the telephone through a knock-out hole in the base of the telephone.

Three of the small keys (Fig. 1), marked SPK TO EXCH, SPK EXTN EXCH HELD, and EXTN TO EXCH, are locking keys, and are pressed to establish three of the circuit conditions provided on Plans 5 and 7. Depression of the fourth small (non-locking) key, marked RELEASE, restores any of the locking keys and establishes a fourth circuit condition—"main to extension." The two large unmarked keys are used to call the extensions. A white lamp behind the EXTN TO EXCH key acts as an engaged signal and lights if this key is depressed when the handset at an extension is off its rest. A red lamp is fitted behind the SPK EXTN EXCH HELD key and lights if this key is depressed when the handset at the main station is off its rest, thereby indicating that the exchange line is being held.

Facilities

Plan 7 with a main station and one internal extension will be discussed first. Incoming calls may be received at the main or the extension and, if received at the latter, the bells ring simultaneously at both. The main and extension call each other with press-buttons, which operate buzzers. The main can hold an exchange call and speak to the extension without being heard on the exchange line. Exchange calls from the main cannot be heard at the extension. The main can intervene on calls between the exchange and the extension.

The facilities of Plan 7A are similar to those of Plan 7, except that calls between the exchange and the extension are secret from the main. Plans 5 and 5A are similar to Plans 7 and 7A, respectively, but have two

extensions. Incoming calls may be received at the main or either extension, the bells being rung simultaneously at the main and both extensions in the latter case. Calling between the main and either extension is by means of buzzers operated by press-buttons. The extension calls are not secret from one another. A second press-button can be provided at each extension telephone to enable them to call each other without the assistance of the main.

Because only two wires are normally provided between the main and external extensions, a 20 c/s ringing convertor is used to ring the magneto bells at the extension telephones. The buzzer at the main is operated by a relay when an earth is applied at either extension. Push-button calling is therefore possible from all telephones. The facilities are the same as with internal extensions except that on Plan 5 the extensions cannot call each other. Intercommunication between external extensions is, however, possible if calls are established through the main.

CIRCUIT DESCRIPTION

The circuit arrangements for Plan 5 and Plan 7 are similar, but, because more facilities are provided by Plan 5, the circuit description will deal with this extension plan.

Installations with Internal Extensions

Fig. 2 is a simplified diagram of a Plan 5 with internal extensions. A brief description follows of the circuit

operation for each of the four conditions provided by Plan 5.

Speak to Extension (all keys normal). Lifting the handset at the main or either extension telephone connects the telephone to the common speech path between stations via E1, X1, and X2. The negative pole of the 12-volt supply is connected to the circuit through the inductor, L, and the positive pole is connected through R2. Calling between main and extension is by buzzers which are operated over separate signalling wires.

Incoming calls from the exchange will ring the bell at the main via E5 and X3.

Speak to Exchange (key X operated). The telephone at the main is connected to the exchange via X1, X2 and E3. An incoming call from the exchange will ring the bell at the main via E5, X3 and GS2.

Speak to Extension, Exchange Held (key H operated). A 300-ohm resistor is connected to the exchange line via GS1 and H1. The main telephone is connected to the common speech path and the extensions may be called by operating the appropriate calling key. The voltage developed across R2, when a handset is lifted, is applied to V2, which becomes conducting and allows relay A to operate. The red lamp on the plan set will light via A3 and H2.

Extension to Exchange (key E operated). The exchange line is connected to the common speech path via E3, R1, R2 and E1. According to the polarity of the exchange

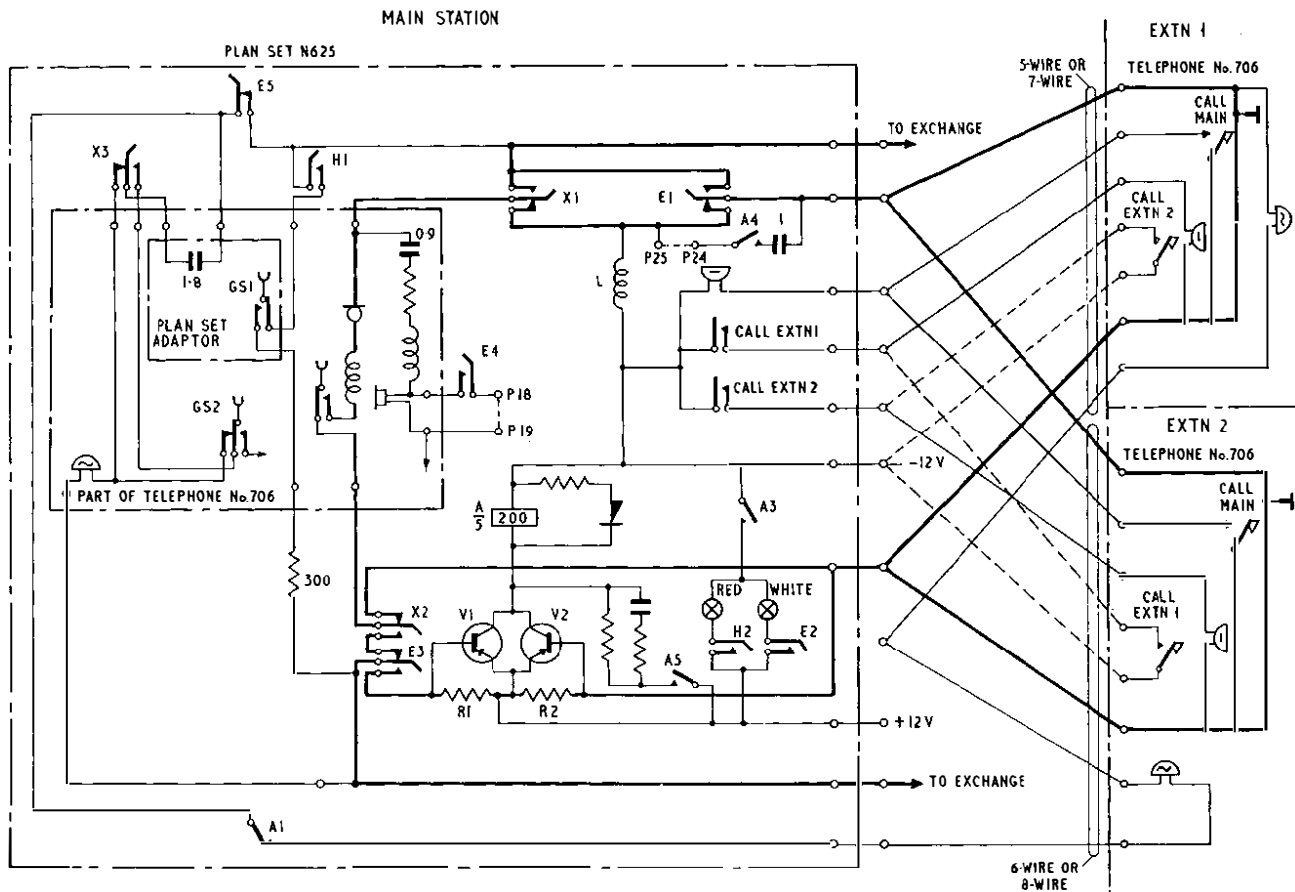

The keys operated for each circuit condition are: speak to extension—none; speak to exchange—X; speak to extension, exchange held—H; extension to exchange—E

FIG. 2—SIMPLIFIED DIAGRAM OF PLAN 5 WITH INTERNAL EXTENSIONS

line either V1 or V2 will become conducting and allow relay A to operate. The use of the transistor switch enables a standard 600-type relay to be used in this circuit. The relay is operated from the 12-volt supply and is controlled by the transistor switch, which is in turn controlled by the line current, which would be too low in value to operate the relay directly. The white lamp lights via E2 and A3. The end of the call is indicated at the main station by the release of relay A, which extinguishes the white lamp.

Extension to exchange calls are secret from the main if plan-set terminals P18 and P19 are strapped. If this strap is removed and P24 strapped to P25, the main station may intervene on such calls.

Incoming calls from the exchange will ring the bells at the main and extensions in series via E1, A1 and X3.

Either of the extensions can make an outgoing call. The operation of relay A will disconnect the bell circuit at A1, and A5 connects a resistance-capacitance network to relay A, to prevent its release during dialling.

Installations with External Extensions

Fig. 3 is a simplified outline diagram of a Plan 7, with an external extension. The circuit differs from that of Fig. 2 only in the signalling arrangements. Three signalling conditions are considered.

Main Call Extensions. The operation of the call-extension key starts the 20 c/s ringing convertor and connects the ringing current to the extension line to ring the earth-connected bell at the extension.

Extension Calls Main. The push-button key on the extension telephone is operated and earth is applied to the negative line. Except when key E is operated, the +12 volts terminal is earthed via E2. The earth at the extension operates relay B and B1 operates the buzzer. When key E is operated the earth connexion will be removed from the power supply by E2. It is essential, therefore, that the negative wire of the exchange line should be correctly connected so that in this condition, with the EXTN TO EXCH key operated, relay B will operate to the exchange battery, which has its positive pole earthed.

Incoming Calls. Except when key E is operated, ringing current operates the bell at the main via E5 and X3 to earth. When key E is operated, the bell at the extension is rung via E1, relay B and the call extension key contacts to earth. Relay B operates in synchronism with the incoming ringing cadences, and B1 operates the buzzer at the main.

For Plan 5 the speech paths of the two extensions are connected in parallel and the bells are connected via thermistors to earth, the bell connexion being to the positive line at one extension and to the negative line at the other. The thermistors prevent bell-tinkling when the other extension dials.

ASSOCIATED APPARATUS

Extension Telephones

At the majority of installations the instrument at the extension will be a Telephone No. 706 with one press-button, which is used to call the main station. On installations with internal extensions additional buttons are sometimes required, for example, to call the exchange on a shared-service installation, to call the other extension on a Plan 5, or to recall the private branch exchange (P.B.X.) operator. On such installations a Telephone No. 710³ must be used.

Ringing Convertor

An interior view of the ringing convertor (Convertor, Ringing, No. 9A), which is intended for wall mounting, is shown in Fig. 4. The circuit and method of connexion are shown in Fig. 3. The ringing convertor also contains relay B, which is a 3,000-type relay shunted with a germanium diode.

Power Unit

The power unit (Power Unit No. 53A) has been designed specially for use with the plan set, and is intended for wall mounting.

To avoid damage to the transistors associated with relay A, the output of the power unit does not exceed 12 volts with the lightest load applied by the plan set. The full-load output is 0.25 amp at 10 volts. The inter-

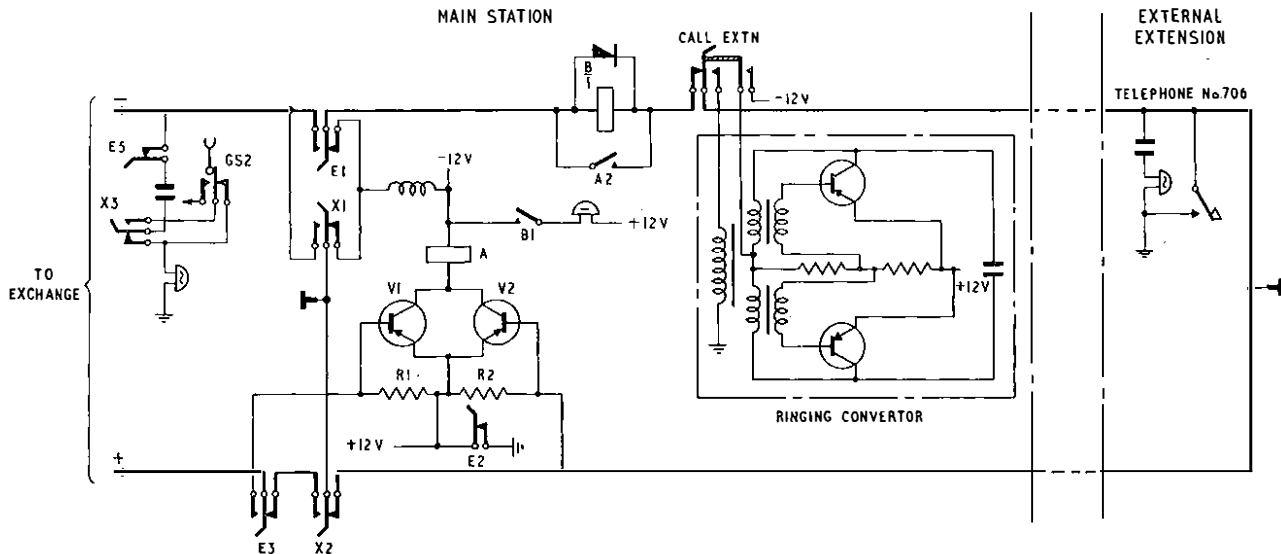

The keys operated for each circuit condition are: speak to extension—none; speak to exchange—X; speak to extension, exchange held—H; extension to exchange—E

FIG. 3—OUTLINE DIAGRAM OF PLAN 7 WITH EXTERNAL EXTENSION

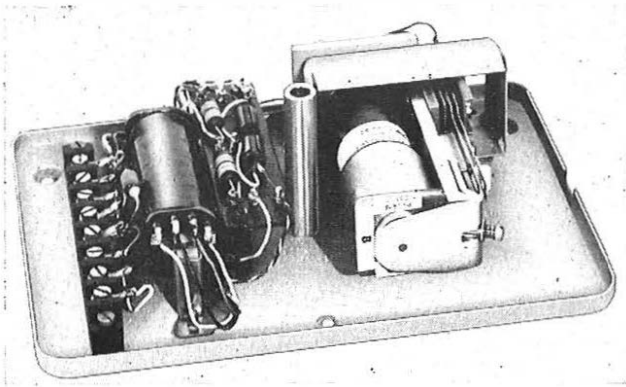

FIG. 4—RINGING CONVERTOR

nationally-agreed upper limit for noise on power supplies is 2 mV (weighted), which is satisfactory when the supply is fed through a transmission bridge. On the plan set, however, where the supply is connected directly to the speech circuit through an inductor, 2 mV of hum was clearly audible and a limit of 0.75 mV was therefore specified. An interior view of the power unit is shown in Fig. 5.

Plan-Set Adaptor for Telephone No. 706

In addition to the change-over and make spring-sets included in all Telephones No. 706 (the term "make" indicating that the contacts are made when the receiver is off the rest), another make spring-set is required in the exchange-hold circuit. A further break spring-set will be required if the plan set is used on P.B.X.s with 4-wire extensions.⁴

A capacitor (Capacitor, Paper, No. 7719) used in Telephone No. 706 consists of 0.9 μ F and 1.8 μ F capacitors in the same case. Coupling between the two capacitors led to distant subscribers overhearing conversations between main and extension with the SPK EXTN EXCH HELD key depressed. The best way of

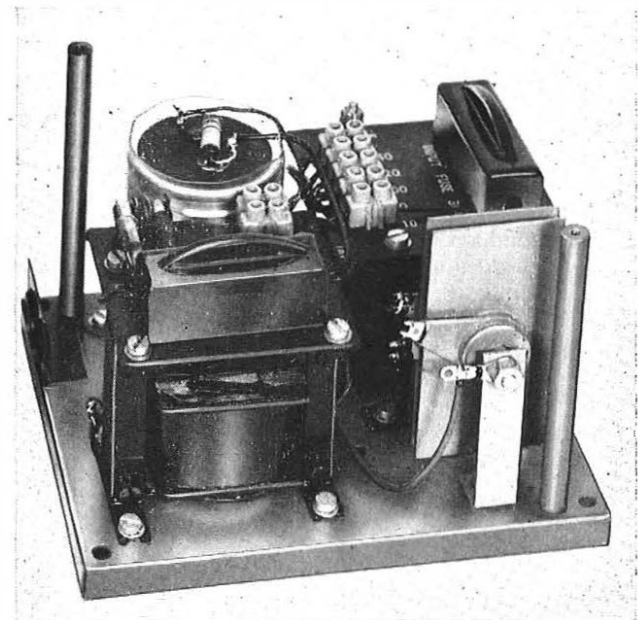

FIG. 5—POWER UNIT

overcoming this overhearing is to use a separate capacitor in place of the 1.8 μ F capacitor in the Capacitor, Paper, No. 7719. Owing to the limited space in the plan set this capacitor was combined with the additional spring-sets previously described to form the Adaptor, Plan Set, No. 1, which is fitted on the side of the gravity-switch bracket opposite to the normal spring-set.

Buzzer

The buzzer (Buzzer No. 32A-1) has a 55-ohm coil and operates from a 12-volt d.c. supply. It is attached, together with its suppression unit, to a bracket which is held under one of the bell-gong fixing screws.



(a) Apparatus required at main station using Plan Set N 625



(b) Apparatus required at main station when Bell Set No. 44 is used

FIG. 6—NEW-STYLE AND OLD-STYLE APPARATUS FOR MAIN STATIONS

CONCLUSION

The design of the plan set was undertaken to provide a switching unit of modern design which would permit the use of Telephone No. 706 at the main station of Plan 5 and 7 installations. The plan set is equally suitable for use by a secretary or an executive who prefers to have the main station on his desk. Increased facilities and extended transmission limits have been attained and it has been possible to reduce the number of items required in addition to the switching unit, especially on installations with external extensions. Fig. 6(a) shows the apparatus required at the main station when a Plan Set N 625 is used and Fig. 6(b) shows the apparatus necessary with a Bell Set No. 44.

ACKNOWLEDGEMENTS

The development of the plan set described in this

article was carried out for the Post Office by the General Electric Co., Ltd., under the British Telephone Technical Development Committee Procedure. The author wishes to thank colleagues in the Subscribers' Apparatus and Miscellaneous Services Branch, especially Mr. F. J. Harvey, who suggested improvements which have been incorporated in the design.

References

- ¹ ELLEN, L. W., and GORDON, S. C. A New Subscribers' Intercommunicating Telephone Set. *P.O.E.E.J.*, Vol. 33, p. 39, Apr. 1940.
- ² SPENCER, H. J. C., and WILSON, F. A. The New 700-Type Table Telephone—Telephone No. 706. *P.O.E.E.J.*, Vol. 32, p. 1, Apr. 1959.
- ³ SPENCER, H. J. C. A Table Telephone with Four Push-Button Keys—Telephone No. 710. *P.O.E.E.J.*, Vol. 53, p. 190, Oct. 1960.
- ⁴ LIDBETTER, E. J. The Four-Wire Extension Principle for Small Cordless P.M.B.X. Switchboards. *P.O.E.E.J.*, Vol. 53, p. 167, Oct. 1960.

Book Reviews

"Problems in Electrical Engineering (Power Engineering and Electronics)." S. Parker Smith, C.B.E., D.Sc., M.I.E.E., A.M.Inst.C.E. Edited by N. N. Parker Smith, B.Sc., A.M.I.E.E. Constable & Co., Ltd. xviii + 370 pp. 20s.

This book is now in its seventh edition and has grown from the 792 problems in the first edition in 1929 to the 1,981 problems in the present edition. The questions, which are all of a numerical character, have the answers given but there are no worked-out examples. There is a short introductory section containing useful miscellaneous data, physical constants, units, magnetization curves, hysteresis loops and thermionic-valve characteristics, all of which will assist in solving the problems. The following chapters cover the whole field of electrical engineering, including such subjects as telecommunications, transistors, costs and economics, heating of electrical plant, traction and lighting. The book is undoubtedly of considerable value to students preparing for examinations.

R. S. P.

"Electronic Computers. Principles and Applications." T. E. Ivall. Published for *Wireless World* by Iliffe & Sons, Ltd. viii + 263 pp. 125 ill. 25s.

This book, written by an assistant editor of *Wireless World*, is described by its author as "... an introduction for those who are beginning to take an interest in electronic computers," which tries "... to give a reasonably broad picture of electronic computing to those who are likely to become involved in some specialized aspect of it ..." The treatment is descriptive, mathematics are avoided, and no great familiarity with electronic techniques is assumed. The book is clear, readable and copiously illustrated.

The first two chapters sketch the history and arithmetical principles of computing machines. Then follow four chapters, occupying about one-quarter of the book, which deal with the circuits, equipment and applications of electronic analogue computers. It is useful to have an elementary account of these machines, for little is known about them outside specialist circles. The next four chapters, about one-third of the book, deal with the circuits and equipment of digital computers. The material is straightforwardly presented, but this reviewer would have preferred the reader to be given a clear picture of the whole machine before discussing in detail the circuits of its part: the simple block diagram (Fig. 8.7) would be better at the start of the

first chapter on circuits rather than where it is—at the end of the second. Two short chapters, on the programming and the use of digital computers, lead on to the last two chapters which deal with recent and future developments.

Some points of detailed comment follow. On p. 118, in discussing a nickel delay-line store, the speed of sound is given as 1,100 ft/sec, which is, of course, its speed in air; in nickel the speed is nearer 16,000 ft/sec.

A comment on p. 133 suggests that commercial computers have only 15 to 200 words of quick-access storage, but several machines now have ferrite-core stores able to hold several thousand words.

It is implied on p. 141 that, tape handling apart, audio recording on magnetic tape is more difficult than digital recording; this ignores the very severe requirements which the latter places on tape quality, to avoid minute imperfections which might lose a single digit. The figure of $1\frac{1}{2}$ million binary digits per track, quoted on p. 144 for the capacity of the Decca tape unit, is not consistent with the recording density and reel length also quoted; the corresponding figure is 2.9 million digits, which agrees with the figure of 23 million digits (for 8 tracks) quoted on p. 164 for the same unit. The author gives the maker's name for most, but not for all, of the equipment illustrated in his plates. Plate 18 (b) is not so labelled, but if the magnetic-disk store illustrated is the I.B.M. R.A.M.A.C. that it appears to be, then the description on p. 147 needs amendment: the storage capacity is not 5 million bits but 5 million binary-coded digits each of 8 bits, i.e. 40 million bits. And, to say that "the access time is of the order of milliseconds" is rather misleading, for the average access time quoted by the manufacturer is 825 milliseconds.

Chapter 10 describes in detail how data are punched into cards or paper tape, but no reference is made to the supreme importance of "verifying" the punching using a second keyboard machine and second operator. To quote an experienced American user: "Computers are sure great at turning trash into trash in microseconds." Chapter 11 gives the impression that computer translation of languages is a well-established practice instead of the infant art it is. On p. 223 the author's enthusiasm for the low power consumption of transistors allows the Emidec computer to draw a 2 kW supply from car batteries (say, 80A at 24V) without adding that these float across a.c. mains rectifiers, and serve principally to reduce the power-source impedance.

These, however, are minor blemishes on a generally excellent introduction to computers.

I.P.O.E.E. Library No. 2436

F. J. M. L.

Induction Hardening of Diagonal-Cutting Nippers

H. D. BROOK, B.Sc., A.I.M.†

U.D.C. 621.788

This article gives a general outline of the induction hardening process and its application to diagonal-cutting nippers. The process, which is used to harden the cutting edges, enables local hardening to be precisely applied. The hardened zone obtained and inspection methods used to check for possible defects are discussed.

INTRODUCTION

THE use of carbon steels for tools largely depends on their ready response to heat-treatment, so that, by variations of the basic method of heating, quenching and tempering, widely different properties corresponding to the different states of the carbon constituent may be obtained. For cutting pliers a hard cutting edge is required, with a lower hardness in the jaws and box to give toughness, and a still lower hardness in the curved shafts to give both toughness and resilience. In the older types of heat-treatment one method used is to quench the nose of the pliers to harden the jaws and box, to allow residual heat from the shafts to run back into the jaws to temper them, and finally to cool the whole tool. With this method the cutting edge is in the same range of hardness as the rest of the jaws. These older methods require individual treatment for each tool and a high degree of skill and judgement in the operator, and are, thus, uneconomic by modern standards. Methods suited to mass production are favoured, either as batch treatments or as single rapid automatic treatments for flow-line production.

The need for a hard surface and a tough core can be met by case hardening (carburizing) and this is used on the jaws of toggle-assisted nippers. However, the development of methods of applying rapid and exactly localized heating enables the need for putting carbon into the steel surface (as in carburizing) to be avoided.

The chief advantages of induction heating are speed and cleanliness, low power costs, high thermal efficiency, absence of scale on the steel being treated owing to the short heating time, and minimum distortion since the surface only is treated. Because the components are handled singly and the time of treatment is short, this type of process can be readily adapted to flow-line production. The space required for the plant is small. For these reasons the introduction of induction hardening by industry was coupled with mass-production methods, and gave a uniform and reliable product with the core of the steel in an ideal condition and the hardened zone precisely located. By 1952 manufacturers were introducing induction hardening to one or two types of Post Office pliers, although the process had been used much earlier in other countries and in other industries. In 1958, after several years' experience of testing and using such tools, the Post Office specification was amended to specifically mention induction hardening, and it is now used extensively on items such as nippers and 8 in. cutting pliers.

When applied to plier-type tools such as nippers, the tool as a whole is first hardened and tempered overall to give the background toughness required. This is done by heating in a furnace (preferably with a controlled

atmosphere to prevent oxidation and scaling) to the hardening temperature, in the region of 800–850°C, then maintaining the temperature for a time sufficient to ensure that the tool is uniformly heated through its section, and finally cooling rapidly by quenching in oil. From this hardened state, the tool is then tempered by re-heating to a lower temperature depending on the final hardness required, but usually in the range 200–650°C. Besides lowering the hardness to the required range, tempering also relieves internal stresses and increases the toughness of the steel. The operations of hardening and tempering can be mechanized without any particular difficulties, and this helps to avoid the variable hardness which might otherwise occur in these tools, and makes inspection easier and more reliable.

The final operation is then to induction harden the cutting edges; but this operation is much more difficult to mechanize since the heated zone must be positioned accurately on the cutting edges, and each item needs individual treatment. By positioning the cutting edges close to an induction coil the surface zone of the steel is heated very quickly, and when this is followed by quenching the surface of the steel is hardened. The necessity for tempering is usually avoided by controlling the quenching rate but, if this is not possible, a tempering process may have to be added to bring the hardness within the specification limits.

THE HARDENING PROCESS AND THE INDUCTOR

Induction heating may be regarded as a special case of a transformer in which a primary coil is used to induce circulating currents in the work-piece as the secondary coil. The current density is higher at the surface of the work-piece than in the centre and this is enhanced by the skin-effect with high-frequency currents. Frequencies from 1,000 c/s to several megacycles per second may be used, and the frequency chosen will depend on the size of the part and the depth of hardened zone required. If a sufficiently high current is induced in the work-piece the heat generated in the surface layer can heat that surface layer to the hardening temperature before any appreciable heat flow to the core of the steel takes place. On quenching, the surface layer is then hardened, leaving the core substantially unchanged.

Usually a single-turn heating coil is used and this has several advantages: the voltage can be kept low and the coil is, therefore, safe in operation; the coil can be made from a massive copper block and is, therefore, very robust; water cooling is easily applied through a hole in the coil; the clearance between coil and work-piece can be kept quite small, e.g. $\frac{1}{8}$ or $\frac{1}{4}$ in.; the single coil is very suitable for a high-power input to achieve a high heating rate. For nippers the coil is usually a simple hairpin loop.

The depth to which the heating penetrates depends mainly on the permeability and resistivity of the material, and on the frequency used. When iron is heated it loses its ferromagnetic properties and becomes paramagnetic at about 760°C. This is the Curie point, and above this temperature the penetration depth of induction heating in steel increases rapidly, comparative figures being:

† Birmingham Materials Section, Test and Inspection Branch, E.-in-C.'s Office.

(a) at 20°C, penetration depth is proportional to $0.08/\sqrt{f}$, and

(b) at 800°C penetration depth is proportional to $20/\sqrt{f}$, where f is the frequency of the applied current.

The efficiency of energy transfer from the inductor to the work-piece depends on the size of the work-piece and the frequency. For bars more than 2 in. thick the efficiencies for all frequencies are much the same, being about 80 per cent, but below 1 in. the efficiencies differ widely and are very low with the lower frequencies. For the smallest sizes, and for case-hardening depths less than about 0.015 in., frequencies of several megacycles per second are necessary.

These factors govern the choice of the heating equipment. For through heating of bars and billets the lower frequencies are used. Alternators are suitable for providing current at these frequencies and they are generally housed in a separate substation, but they become uneconomic above 10 kc/s. The higher frequencies are used for surface heating, as with nippers, and for these valve oscillators are suitable, operating typically at about 400 kc/s with a power capacity of 10–25 kW, and a power concentration on the work of 5–20 kW/in.² The plant usually comprises a high-tension transformer and rectifier with a high-frequency triode oscillator unit, and is reasonably small and quiet, fitting neatly into shop layouts or production lines. Automatic control of the power level is incorporated together with



The air-blast pipe situated above the induction-heating loop is used when a more rapid quenching is required

FIG. 1—NIPPERS POSITIONED UNDER INDUCTION-HEATING LOOP

automatic timing, so that the whole process may be pre-set. The operator merely puts the nippers in position close to the heating loop (Fig. 1) and presses the starter button. The machine switches on the current for the pre-set time and switches off, and the operator allows the tool to drop into the quenching tank.

The quenching method used depends on the steel, the hardness required and the process used. For example, with nippers, quenching in soluble oil may be used, possibly preceded by an air blast where more rapid quenching is required.

STEEL COMPOSITION AND CONDITION

Induction hardening is usually applied to plain carbon steels but alloy steels may be used, especially to obtain specific core properties. With carbon below 0.35 per cent, plain steels do not respond much to hardening. For general purposes the most useful balance of properties is obtained with medium carbon contents of 0.5–0.6 per cent, and above 0.6 per cent core ductility begins to decrease. It is easier to get a hard wear-resistant cutting edge on nippers with a somewhat higher carbon range of 0.65–0.75 per cent. Little ductility is sacrificed with this range, and tool steels of this carbon content are usually cleaner than the medium-carbon steels. The presence of slag and other inclusions in a thin hardened zone may lead to cracking.

The condition of the steel is important, since to obtain a rapid response to the very short heating times involved it is necessary to start with a structure which is homogeneous and fine. Thus, the structures obtained by hardening and tempering are very suitable whereas with an annealed or softened structure consisting of separated grains of ferrite (iron) and pearlite (the carbon constituent) the response to hardening may be patchy and unsatisfactory. The ferrite grains do not harden as they contain virtually no carbon, and there is often insufficient time for the carbon from the pearlite to diffuse into the ferrite grains to enable them to respond to heat-treatment. For the same reason surface decarburization is objectionable, since much of the carbon in the surface layers has been removed by oxidation or other means.

CONTROL OF THE PROCESS

With the induction-hardening process there is less chance of distortion, and the internal stress produced is less than with normal hardening. A higher maximum hardness can therefore be allowed on the cutting edge and the specification has been amended to call for a range of 540–800 Vickers hardness number with induction hardening, instead of 540–620 (500–550 Brinell) as formerly allowed. The maximum of 800 is intended to eliminate the possibility of shattering very hard cutting edges by the shock waves generated when cutting wires and, also, to reduce the risk of forming quench cracks during or after the very drastic quenching which produces the higher hardnesses. Magnetic crack-detection tests are used on nippers to detect quench cracks or forging cracks.

The position and shape of the induction-hardened zones is important, and etching with dilute nitric acid is used to reveal the pattern and position of the hardened zone. The zone should be correctly orientated with respect to the cutting edge, and two patterns which are normally obtained with nippers are shown in Fig. 2. The larger pattern is produced with a lower frequency at

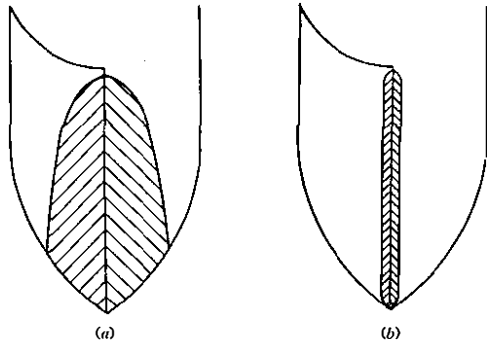

(a) Pattern produced by low-frequency induction heating
 (b) Pattern produced by high-frequency induction heating

FIG. 2—CORRECTLY ORIENTATED PATTERNS OF INDUCTION-HARDENED ZONES

5–10 kW energy input and heating times of 3 or 4 seconds. The smaller pattern is produced with a higher frequency at about 35 kW input with a heating time of about $\frac{1}{2}$ second.

Positioning and time control are more critical with the second pattern, e.g. if the pattern is slightly askew with respect to the cutting edge one of the tips of the nippers may be soft and will curl over in use. Again, a small decrease in the time may produce a very shallow hardened zone (say, less than 0.03 in. deep from the edge) which will eventually indent on cutting, or a small increase in the time may produce a zone spreading round the tips, as in Fig. 3, and the tips will be brittle and tend to break off in use.

Whilst nippers are really delicate tools intended for cutting cleanly the softer wires, they must be designed to withstand general handling, including a certain amount of rough treatment. Some failures may occur through

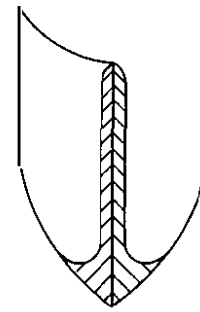

FIG. 3—PATTERN OF INDUCTION-HARDENED ZONE DUE TO EXCESSIVE TIME OF HEATING

the application of excessive loads in use, but a loading test has been included in the specification to help to ensure that nippers will stand up to normal use. With this test a compressive load of 180 lb is applied across the curved shafts at the position of maximum bow, and the deflexion and permanent set are measured. These should be not more than 0.5 in. and 0.05 in., respectively. Since the nippers will cut a 0.064 in. diameter 50-ton tensile-steel wire with a load of 100–150 lb, this testing should ensure that nippers will cut copper wires with a very high factor of safety.

CONCLUSION

Induction hardening offers to the Post Office a precision method of surface hardening and a ready means of separating the surface properties of an item from the core properties. The products should be more reliable and uniform, with scaling, decarburization and distortion minimized. The method is already applied to cutting tools such as nippers, and is being increasingly applied to instrument parts.

Book Review

“The Testing of Electrical Machines.” L. H. A. Carr, M.Sc.Tech., M.I.E.E., A.R.P.S. Macdonald & Co. (Publishers), Ltd. 299 pp. 150 ill. 50s.

This book is intended primarily for the use of testing staff and, consequently, the manner of presentation of the subject matter is more suited to such readers than to the student. The technical standard is approximately that of the Higher National Certificate in Electrical Engineering, and the author assumes that the reader is familiar with the fundamental principles of operation of electrical machines. As there is no reference in the book to single-phase machines or to 3-phase commutator machines the title is a little misleading.

Before dealing with the various types of machines there is a list of symbols and of British Standard specifications used in the book, and also some general notes on testing principles relating particularly to high-voltage, temperature, speed and efficiency tests. One chapter only, of 18 pages, is devoted to the d.c. machine, the remainder of the book dealing with most of the common types of polyphase a.c. motors and generators. The chapter on the induction motor discusses the general theory of the machine and the construction of the circle diagram, and then describes the usual tests required; after this a worked-out example is given for a particular squirrel-cage motor. The same procedure of following the descriptions of the various tests by a worked-

out example for a particular machine is followed throughout the book and is a useful feature.

There are two chapters on the theory of the synchronous machine, including vector diagrams of the generator and motor, the analysis of short-circuit oscillograms and leakage reactances. The three chapters on synchronous machines describe the fundamental magnetization short-circuit, temperature and efficiency tests, and follows with detailed numerical examples of the tests on a typical 500 h.p. synchronous induction motor and on a 2,200 h.p. synchronous motor. Hereabouts, however, the arrangement of some of the material and the chapters could probably be improved. The a.c. generator is covered in two chapters, which include an explanation and a detailed description of the sudden-short-circuit test to check the mechanical stability of the machine and determine the short-circuit currents. The later chapters in the book deal with the synchronous condenser, the turbo-generator, testing procedure and precautions, and balancing of rotating parts.

The printing of the book is of good class although the reproduction of the illustrations and line diagrams is not so good. Many of the diagrams, although readily understood, have lines of varying thickness and there is appreciable line-smudging on many diagrams. There is a minor error on page 50 where the reference should be to curve 2.8 and not to curve 2.5.

The book contains a good deal of useful technical and practical information that will be of particular value to those concerned with the testing of machines. R. S. P.

Polythene-Sheathed Underground Telephone Cables

H. C. S. HAYES, C.G.I.A., M.I.E.E.†

U.D.C. 621.315.23:621.315.221.8:678.742.2

Small cables insulated and sheathed with polythene have been used successfully in local distribution networks for some years, and such cables have now been adopted for general use in sizes up to 100 pairs. The use of this type of cable in sizes up to 2,000 pairs is being tried experimentally. Trials are also to be carried out on polythene-sheathed paper-insulated cables both in local distribution networks and junction schemes. The advantages of both types of cable are discussed and the factors likely to influence their use are reviewed.

INTRODUCTION

POLYTHENE, although inferior to lead in its resistance to the passage of water vapour, is sufficiently good in this respect to be useful as a cable sheathing. Cables so sheathed have the advantages of being flexible, light and clean to handle, and of being entirely free from corrosion troubles. Already polythene is being used fairly extensively for sheathing small underground telephone cables, and the experimental work now being undertaken to determine the desirability of extending its use to large cables will be described.

Polythene-sheathed cables can broadly be divided into two classes—those in which polythene is used both for the sheath and for insulating the wires, and those in which the conventional paper wrappings are retained for the latter function.

POLYTHENE-INSULATED CABLES

In local distribution networks polythene-insulated and polythene-sheathed cables have been used in sizes up to 30 or 50 pairs for several years, and experience with this "all-polythene" construction has been sufficiently good for this type of cable to be adopted for general use in such networks, from 1 April 1960, in sizes up to 100 pairs. Present practice is to joint all but the smallest of these cables with expanding-plug joints¹ and to limit a possible flow of water along the cable in the event of a sheath defect by fitting a wax water-barrier at each neck-end of cable at all joints. Some 30,000 sheath miles of all-polythene cable have been installed, some in duct but mostly buried directly in the ground.

The question naturally arises as to whether all-polythene cables could be used with advantage in larger sizes. To study their performance and the economics of their use, about 30 sheath miles of such cable, having 4 lb, 6½ lb, or 10 lb per mile conductors and ranging in sizes from 150 to 2,000 pairs, are under trial. The experimental cables have been supplied by a number of different manufacturers and there are variations in the designs as regards make-up, colour scheme, insulant thickness etc. All these trial cables form part of local distribution networks in some 30 different exchange areas and are thus subject to representative working conditions. Several different jointing methods are being tried out. In all these instances the cables are laid in duct.

The cable lengths were thoroughly tested in the factory and again just prior to and after installation. Repeat tests will be made periodically to keep the electrical characteristics of the cables under review. The information so gained, together with the installation experience and a close study of the subsequent fault history, will enable useful conclusions to be drawn.

Trials of new types of cable always tend to take rather a long time, but some desirable features of large all-polythene cables have already made themselves apparent. The cables are light and clean to handle, and the low coefficient of friction between the polythene sheath and the duct allows the drawing-in, normally without any lubricant, of lengths two or three times as great as is usual with conventional paper-insulated lead-sheathed cables, and consequently the savings in jointing and jointing-chamber costs can be considerable.

A significant difference between large all-polythene cables and the smaller ones up to 100 pairs is the considerably greater difficulty of providing the larger cables with water barriers at the joints. Naturally, the problem of sealing the interstices between wires sufficiently to prevent water, which may enter the cable in one length as a result of sheath damage, passing on to adjacent lengths is much more difficult if there is a multiplicity of pairs and no attempt is made to provide a seal. How important is the need for such sealing will thus be shown up by the trials. It has to be borne in mind that once water has entered through the sheath of a local distribution cable, in which, of course, the working wires are normally connected to the exchange battery, any small pinholes or other defects in the wire insulant are points at which conductors may in some circumstances tend to corrode rapidly; one of the objectives of the trial is to assess the importance, if any, of this hazard. Some subscribers' line circuits in experimental electronic-exchange designs include a battery with its earth connexion at other than the conventional position at the positive pole. The extent to which this may increase the risk of conductor corrosion is being observed.

PAPER-INSULATED CABLES

The small size all-polythene cables already referred to have an important advantage in that they can be terminated directly on terminal blocks and similar items without the use of sealing boxes filled with wax, or, alternatively, the use of short lengths of special terminating cable, as is usual with paper-core cables. Since these small all-polythene cables are used in comparatively short lengths and the number of terminations is relatively large, this advantage weighed heavily among the considerations which led to the adoption of such cables for general use. For the larger sizes of subscribers' cables, however, and for junction cables, the terminating problem is comparatively less important because such cables have fewer terminations in relation to their lengths. In both these fields all-polythene cable has a competitor in cable with a paper-insulated core within a polythene sheath. Like their all-polythene rivals these paper-insulated cables are light and easy to handle and the pulling-in of long lengths is a comparatively easy matter.

A few lengths of paper-insulated polythene-sheathed cable were put on trial in 1948 and 1949 and the results were sufficiently encouraging for an experimental cable of this form to be laid some 5 years later between Dover

† External Plant and Protection Branch, E.-in-C.'s Office.

and Deal, a distance of about 9 miles. This junction cable² is loaded and has 54 pairs between its main terminations, with a 28-pair spur about half-way along its length into Kingsdown; the conductors are 0.044 in. diameter aluminium, electrically equivalent to 20lb/mile copper.

When the Dover-Deal cable was laid in 1954-55 it was foreseen that, as polythene is not absolutely impervious to water vapour, there would be a slow drop in the insulation resistance of the cable with the passage of time, and provision was made for pumping dry air through the cable, should this be necessary, to restore the insulation resistance to its former value. The cable was also kept under continuous air pressure of 10 lb/in² with the object of detecting and locating any small holes in the sheath which might otherwise remain undetected and allow the ingress of moisture. It was desired to observe the effects on the paper insulation of the slow diffusion of moisture through the polythene sheath. The presence of any small defects in the sheath would have masked such effects.

The cable was brought into service in June 1955. Although there have been a number of minor air leaks at the joints, the cable has been entirely fault-free from the service point of view. The insulation resistance has dropped slightly, as predicted, but it has been quite unnecessary so far to resort to desiccation by pumping dry air through the cable.

Insulation resistance measurements taken on representative pairs in the Dover-Deal cable have given the results shown in Table 1.

TABLE 1
Insulation Resistance Measured on Dover-Deal Cable

Year	Insulation Resistance (megohm-miles)			
	One minute's electrification (wire 31 A to wires B, C and D, earthed)		Continuous electrification (wire 52A to wire B, earthed)	
	Summer	Winter	Summer	Winter
1955	15,000	—	—	—
1956	—	—	50,000	—
1956/57	—	—	—	600,000
1957	—	—	40,000	—
1957/58	—	—	—	550,000
1958	7,000	—	20,000	—
1958/59	—	21,000	—	500,000
1959	5,000	—	20,000	—
1959/60	—	14,000	—	400,000

It will be noted that the insulation resistance reading at summer temperature in 1959 after 1 minute's electrification is a third of what it was in 1955. The 5,000 megohm-miles figure for the latter date is, of course, still high and it could possibly drop to less than 1 per cent of this value without producing any degradation in transmission or signalling. Later on it is hoped to complete the experiment by attempting to restore the insulation resistance of all, or part, of the cable to its initial value.

There is a difference of some 12°C between the winter and summer cable temperatures, and the corresponding insulation-resistance figures after one minute's electrification are in the ratio of 3:1 approximately; under continuous electrification the ratio is 12:1 or more. In the latter test segregation of the conducting ions at

the electrodes is presumably more nearly complete.

The British Electrical and Allied Industries Research Association, the E.R.A., has developed a method of determining the condition of a dielectric by making "dispersion" measurements.³ They kindly agreed to apply this technique to the Dover-Deal cable. It is perhaps of interest to record the E.R.A. comments on two sets of measurements made in June 1955 and July 1958.

"A comparison of the two sets of tests seems to indicate a slight deterioration in both dispersion and insulation-resistance readings. This deterioration, although significant so far as the measurements are concerned, does not appear to be large enough to give rise to concern in regard to the state of the dielectric."

Although 5 years is not long in the life of a cable, the experience gained from the above experiments has led to the conclusion that further trials with paper-insulated and polythene-sheathed cable are justified for both subscribers' and junction cables. For subscribers' use about 16 miles of this type of experimental cable are in course of installation. The cables are of different sizes from 150 to 800 pairs with both 4 lb and 6½ lb per mile conductors and, as they will work under the same conditions as the large size all-polythene experimental cables, it will be possible to compare the merits of the two types.

As the lengths of subscribers' cables are mostly short they will not all be kept under air pressure. Should it be necessary to improve their insulation resistance by pumping dry air through them, this will be arranged by using portable equipment rather than the type of installed apparatus which is a feature of the Dover-Deal trial. However, as several of these cables are larger than the Dover-Deal cable, and, as the ratio of the volume of absorbent insulating paper to the area of the sheath is, of course, proportional to diameter, there is reason to expect a better performance from these larger cables. On the other hand, some of the sheaths have been made rather thin, and they all contain carbon black; these differences will doubtless in some degree tend to increase the diffusion rate. Much useful information is expected to emerge from a study of the effects of these differences and it will supplement that accumulating from the Dover-Deal experiment.

Five experimental junction-cable schemes, following the general lines of the Dover-Deal scheme except that the conductors will be copper instead of aluminium, are planned to go ahead shortly. The proposals are listed in Table 2.

TABLE 2
Experimental Junction-Cable Schemes

Scheme	Cable Size	Length (miles)
Slough-Staines	542 pair 20 lb/mile	6.5
Guilford-Woking	384 pair 20 lb/mile	7.0
Crawley-Horley	308 pair 20 lb/mile	6.0
Sevenoaks-Tonbridge	96 pair 20 lb/mile	7.5
Formby-Liverpool No 3	104 pair 20 lb/mile	5.8
	338 pair 20 lb/mile	1.5
	434 pair 20 lb/mile	2.5
	504 pair 20 lb/mile	2.3

There will be no carbon black in the sheaths of the cables for the Slough-Staines, Sevenoaks-Tonbridge and Formby-Liverpool schemes.

The main point of interest in these five cables will be the inclusion of a polythene-backed aluminium helical tape around the core, directly under the polythene sheath. The tape is covered on one side with a thin layer of polythene, which adheres strongly to it, and during the manufacture of the cable the processed tape is applied over the completed core with the polythene surface outermost. During the sheathing process which follows, the hot polythene from the extruder adheres to the polythene surface of the tape and the result is that the aluminium tape is bonded to the inside surface of the sheath, sealing a high proportion of its area against the possible ingress of water-vapour molecules.⁴ The idea improves upon an earlier suggestion for sealing, with polyisobutylene, the overlap between the two helical 2-mil aluminium tapes which were included in the Dover-Deal design. At that time this method was not adopted because the polyisobutylene tended to migrate into the paper core. Preliminary laboratory tests on short lengths of the new type of sealed cable show it to be very promising, the indications being that the mean rate of permeation of water vapour is reduced to about one twentieth compared with that through a similar sheath without the tape.

JOINTING

The jointing of a polythene sheath poses special problems. While the expanding-plug joint is the accepted standard for all-polythene cables between 10 and 100 pairs and has acquitted itself well on the Dover-Deal paper-insulated cable, which is under air pressure, there

is a general desire for an alternative type of joint for larger cables. Studies of several alternative forms of joint which may be suitable for all cables of the foregoing types, whether or not they are under air pressure, are therefore being made. The great part played by the expanding-plug joint in the development of polythene cables should not however be underrated. This type of joint was devised by W. R. N. Moody in the very early stages and is still used in substantially its original form. It is very likely that at least the first two of the five junction cables referred to in Table 2 will be fitted with this form of joint.

CONCLUSION

All the foregoing experimental work is primarily directed towards reducing both installation and maintenance costs. That it can be very rewarding is clear, for about a quarter of the Post Office capital investment lies in the cables and ducts used for local lines and for junctions.

References

- ¹ DONOVAN, J. G., and LANFEAR, J. S. A New Method of Direct Underground Distribution. *P.O.E.E.J.*, Vol. 46, p. 183, Jan. 1954.
- ² HAYES, H. C. S. The Dover-Deal Experimental Cable. *P.O.E.E.J.*, Vol. 48, p. 224, Jan. 1956 and Vol. 49, p. 22, Apr. 1956.
- ³ MOLE, G. The Dispersion Meter, Design and Development. The British Electrical and Allied Industries Research Association Report No. V/T 121.
- ⁴ GLOVER, D. W., and HOOKER, E. J. A Moisture Barrier for Polythene-Sheathed Cables (In this issue of the *P.O.E.E.J.*)

Book Reviews

"Elements of Radio Engineering." H. I. F. Peel, M.Sc.Tech., A.M.C.T., A.M.I.E.E. Cleaver-Hume Press, Ltd. vii + 257 pp. 158 ill. 13s. 6d.

In May 1958 the City and Guilds of London Institute announced far-reaching changes in their examination arrangements for telecommunications subjects. The examination scheme and syllabuses were rearranged and the first examinations under the new syllabuses were held in 1959. No examinations in the former subjects Radio I, Telecommunications (Principles) I and II, will be held in future. It is surprising, therefore, to find that the dust wrapper of the second edition (1960) of "Elements of Radio Engineering," by H. I. F. Peel, should declare that the book "... primarily covers the syllabuses of Radio I and Telecommunications (Principles) I and II."

The arrangement of the book is unusual, starting with thermionic valves and dealing with triode amplifiers in Chapter 3 before reaching elementary a.c. circuit theory in Chapters 4 and 5. A good chapter devoted to tuned circuits is, curiously, separated from those on inductance and capacitance by one on power-supply circuits. Other chapters which follow deal with oscillators, detectors, complete receivers, measurements, the cathode-ray oscilloscope and transistors.

The text is written in an easy conversational style well suited to the type of reader who will use such a book, but the depth of treatment is inadequate in places, even for an elementary textbook. For example, a much fuller explanation of the equivalent-circuit diagrams referred to on page 52 would lay a surer foundation for later studies.

In the section dealing with modulation, the author commits the sin of referring to side frequencies as side-bands

instead of setting the student off along the right road by clearly distinguishing between these terms.

The final chapter, on transistors, is short and inadequate. It does not acknowledge the inescapable fact that the transistor is rapidly ousting the valve in the new generation of communication equipment. This fact must be faced by our educationalists if we are to have technicians and engineers properly trained to meet this rapidly advancing new era.

No student is wise to rely on a single textbook when preparing for an examination. This book does not fully meet the needs of students preparing for the Radio and Line Transmission A, and Telecommunication Principles A and B examinations of the City and Guilds. Nevertheless, within its limitations it can be recommended as a useful contribution.

I.P.O.E.E. Library No. 2592.

J. S. W.

"Experimental Plastics." Second edition. C. A. Redfarn, B.Sc., Ph.D., F.R.I.C., and J. Bedford, B.Sc., A.R.I.C. Iliffe & Sons, Ltd. xii + 140 pp. 18 ill. 22s. 6d.

This book provides a practical course of study in plastics for students taking a degree or diploma course in technology that includes plastics, and is divided into four sections—Resin Preparations, Compounding, Fabrication, and Testing.

It is the only comprehensive book of its kind published in English and is excellent for its purpose. In the Post Office it is only likely, however, to be of interest to the few people concerned with making, processing or fabricating plastics for experimental purposes; for these groups it is the only comprehensive book available. The tests are mainly those of the relevant British Standards.

A. A. N.

A Moisture Barrier for Polythene-Sheathed Cables

D. W. GLOVER, M.Sc., F.R.I.C., and E. J. HOOKER, M.A., Ph.D.†

U.D.C. 621.315.221.8:678.742.2 + 669.71

A polythene sheath having a moisture barrier of aluminium foil bonded to its inner surface is described. Tests indicate that paper-insulated cables provided with such sheaths should maintain their insulation resistance for at least several decades.

INTRODUCTION

THE potential advantages of non-metallic cable sheaths, namely lightness, flexibility and freedom from corrosion, have long been recognized. Consequently, when polyvinyl-chloride (p.v.c.) became available during the 1930s, consideration was given to its use for cable sheaths. Preliminary work, however, soon showed that this material is sufficiently permeable to moisture to reduce the life of the paper insulation, commonly employed in telephone cables, to an uneconomic value. Nevertheless, during the war the lead shortage in Germany compelled the use of p.v.c. for sheathing certain cables, the cores of which were kept adequately dry for a considerable time by the expedient of sandwiching a relatively impervious material, such as bitumen, between lappings of aluminium tape, thus forming a moisture resistant labyrinth.

With the advent of polythene, which is more resistant to the permeation of water vapour than p.v.c., this development was continued and in the U.S.A., for instance, led to the eventual production of the "Alpeth" and "Stalpeth" sheaths,¹ the latter providing hermetic sealing by a thin corrugated-steel inner sheath applied longitudinally and soldered between its overlapping edges. These products are now in extensive use and give satisfactory service, but require elaborate and expensive machinery for their manufacture.

In Great Britain the Post Office jointed a number of experimental lengths of plain polythene-sheathed cable into various existing routes during the years following the war, and, as these experimental lengths behaved promisingly, a 9-mile section, equipped so that its performance could be carefully observed, was laid between Dover and Deal in 1954-55.² Subsequent measurements of this cable³ have shown a slow fall in insulation resistance such as would be caused by the ingress of moisture, though the cable will clearly remain serviceable without attention for some time to come, and it can if necessary be desiccated by pumping dry air or carbon dioxide through it. Nevertheless, there is still scope for improving the moisture resistance of thermoplastic cable sheaths in order to provide long trouble-free life, and a simple inexpensive technique for obtaining such an improvement will be described. Patent protection for this invention is being sought in Great Britain and a number of overseas countries.

THE MOISTURE BARRIER

The new sheath derives its resistance to the permeation of moisture from a layer of aluminium foil firmly bonded to the inner surface of the polythene. Suitable foil, about 0.003 in. thick, is commercially

available already coated on one side with a layer of polythene by a hot extrusion process which produces a very strong adhesion between the two materials. This laminate is applied to the cable core with its polythene surface outward, so that, when the resulting assembly is covered with polythene by extrusion, the sheath welds to the coating on the foil whilst still hot, thus firmly bonding the foil to substantially the whole of the inner surface of the sheath. If the foil is forcibly peeled from the sheath, failure of the bond occurs between the metal and its original polythene coating.

The protective efficiency of the treatment has been assessed in terms of its "Sealing Factor," which is defined as the ratio of the respective rates, under similar ambient conditions, at which moisture permeates a plain polythene sheath and an identical one provided with the moisture barrier.

Specimens for the determination of this value are obtained by withdrawing the cores from equal lengths of the appropriate cables. The sheaths are then immersed in water at room temperature and connected into separate closed air-circulating systems, each provided with a desiccant tube for collecting and weighing the entering moisture. One of the earliest lengths of the new cable was appraised in this way after it had been drummed and undrummed several times to simulate laying treatment. The test was carried out for several months and gave a "Sealing Factor" of approximately 20, though this figure is probably pessimistic for reasons associated with the shortness of the sample examined. Also, in this instance, the aluminium had failed to bond to the sheath at isolated spots totalling about 3 per cent of the total area.

Later manufacturing experience has almost eliminated this latter defect, and it is now apparent that such sheathing would ensure the satisfactory insulation of cable cores of the Dover-Deal type for at least several decades.

The layer of foil has the additional advantage of serving as an electrostatic screen to the cable, and if made electrically continuous it can also be used for locating any sheath faults which may develop in service.

A number of cables to be installed for the Post Office during the next few years are to be provided with the improved sheath.

ACKNOWLEDGEMENT

The new method of improving the moisture resistance of thermoplastic cable sheaths was developed jointly by the Post Office and Southern United Telephone Cables, Ltd.

References

¹ PADOWICZ, H. N. The Development of Alpeth-Stalpeth Cable Sheath. *The Western Electric Engineer*, Vol. 3, No. 1 p. 24, Jan. 1959.

² HAYES, H. C. S. The Dover-Deal Experimental Cable. *P.O.E.E.J.*, Vol. 48, p. 224, Jan. 1956, and Vol. 49, p. 22, Apr. 1956.

³ HAYES, H. C. S. Polythene-Sheathed Underground Telephone Cables. (In this issue of the *P.O.E.E.J.*)

† Mr. Glover is at the Post Office Research Station and Dr. Hooker is with Southern United Telephone Cables, Ltd.

A New Cross-Connexion Assembly for Cabinets and Pillars

R. W. HAYWARD, A.M.I.E.E., and F. W. ANGELL†

U.D.C. 621.315.687.2:621.395.743

Cabinets and pillars providing facilities for cross-connecting cable pairs have been used in local line networks for a number of years. To enable the terminating capacity of existing pillars to be increased without costly rearrangements of plant, a new type of cross-connexion assembly has been developed. This unit is also suitable for use in cabinets.

INTRODUCTION

TO ensure efficient use of the cables in a local line telephone network, cross-connexion facilities are provided at various points in the network. By this means spare cable pairs from the exchange may be connected as required to any distribution point in the area concerned. The cross-connexion facilities are provided by cabinets and pillars which contain vertical formations of terminal strips known as assemblies, and these enable cross-connexions to be made between any two cable pairs terminated on them. At present the assemblies used in pillars differ in detail from those used in cabinets and the two types are not interchangeable. The development of a modified 100-pair assembly suitable for use in cabinets as well as pillars and which will supersede existing types of assemblies is described.

The original type of assembly consisted of several open-type connexion strips on each of which 10 cable pairs could be terminated on both the exchange and distribution sides. This was usually termed a 10 + 10 arrangement. For use in pillars there were assemblies catering for 50 or 70 pairs, with five or seven connexion strips, but the 70-pair assembly required a pillar which was approximately 4 ft high and it was not popular.

An enclosed-type connexion strip (so called because the terminals are enclosed in a bakelite moulding) with facilities for terminating 20 + 20 pairs was subsequently developed. It occupied the same space as the open-type connexion strip, thus effectively doubling the number of cable pairs which could be terminated in the existing cabinets and pillars. The 50-pair pillar could thus be converted to terminate 100 pairs, and the opportunity was taken to dispense with the 70-pair pillar, partly because of its size and partly because there seemed no call for a pillar assembly of 140 + 140 pairs. Two smaller assemblies were also introduced, catering for 74 + 74 pairs and 54 + 54 pairs. The three sizes, 100 + 100, 74 + 74 and 54 + 54 pairs, have since remained standard sizes for pillar assemblies.

The continued growth of the telephone system over a number of years at an unexpectedly high rate resulted in the terminating capacity of many pillars becoming fully utilized. It was not possible to increase their capacity by adding additional assemblies, as could be done with cabinets, because each pillar was designed to accommodate only one assembly. Additional pairs could only be terminated by either

(a) providing an additional pillar or pillars,

(b) replacing a pillar by one of a larger size, or
(c) substituting a cabinet for a pillar.

Each of these methods involved costly rearrangements of plant, and a cheaper solution to the problem was required. To restrict initial capital expenditure and to avoid excessive costs later, a method was required whereby the terminating capacity of a pillar could be increased after it had been installed and was in service. Such a requirement indicated an arrangement somewhat similar to that used for cabinets, in which additional assemblies could be fitted as necessary.

THE NEW ASSEMBLY

Development

To meet requests that it should be possible to extend the capacity of a pillar without the need to disturb the existing assembly, a tentative design of pillar was produced utilizing standard cabinet assemblies. With this design a 100 + 100 pair cabinet assembly¹ could be installed initially and another provided at a later date, or, alternatively, where the full capacity was required initially, one 200 + 200 pair cabinet assembly could be fitted. However, the size of the pillar necessary to house these assemblies was such that the cover required would have been extremely heavy and unwieldy. It was also difficult to provide satisfactory arrangements for making the pillar air-tight. Similar problems also occurred with a pillar designed to accommodate two standard pillar assemblies side by side.

Other methods were therefore investigated, mainly in an effort to obtain greater capacity in the same space. However, while it would have been possible to produce a vertical assembly having a capacity of 150 + 150 pairs, or possibly even 200 + 200 pairs, in approximately the same space as that occupied by a standard 100 + 100 pair assembly, it would have been difficult to arrange the termination of the cable pairs satisfactorily. For such a design to be practicable a 200-pair cable having a substantially smaller diameter than that of the normal type of paper-insulated and lead-sheathed cable was essential, and no such cable was available.

The possibility of using plastic insulated and sheathed cable for the assembly cable tails had been explored earlier, but at that time the manufacture of a suitable cable was not practicable. With the later advances in cable manufacturing techniques, however, this possibility was re-examined and ultimately a 100-pair cable of quad formation having p.v.c.* insulation and sheath was produced. With this type of cable it is not necessary to embed the cable forms in an insulating compound. The design of a narrower assembly without a projecting cable gland-box thus became possible. The diameter of the cable was similar to that of the paper-insulated lead-sheathed types, however, and it was concluded that a vertical assembly with a capacity of 100 exchange-side and 100 distribution-side pairs would best meet the requirements. This meant that a narrower connexion strip than that used on the previous design of assembly could be employed and, in view of the decision to retain a 100 + 100 pair vertical assembly, the continued use of

† Mr. Hayward is in the Local Lines and Wire Broadcasting Branch, and Mr. Angell is in the External Plant and Protection Branch, E.-in-C.'s Office.

¹ HARDING, J. P. and HUMPHREYS, A. J. Flexibility Units for Local Line Networks. *P.O.E.E.J.*, Vol. 39, p. 159, Jan. 1947.

* p.v.c.—polyvinyl-chloride.

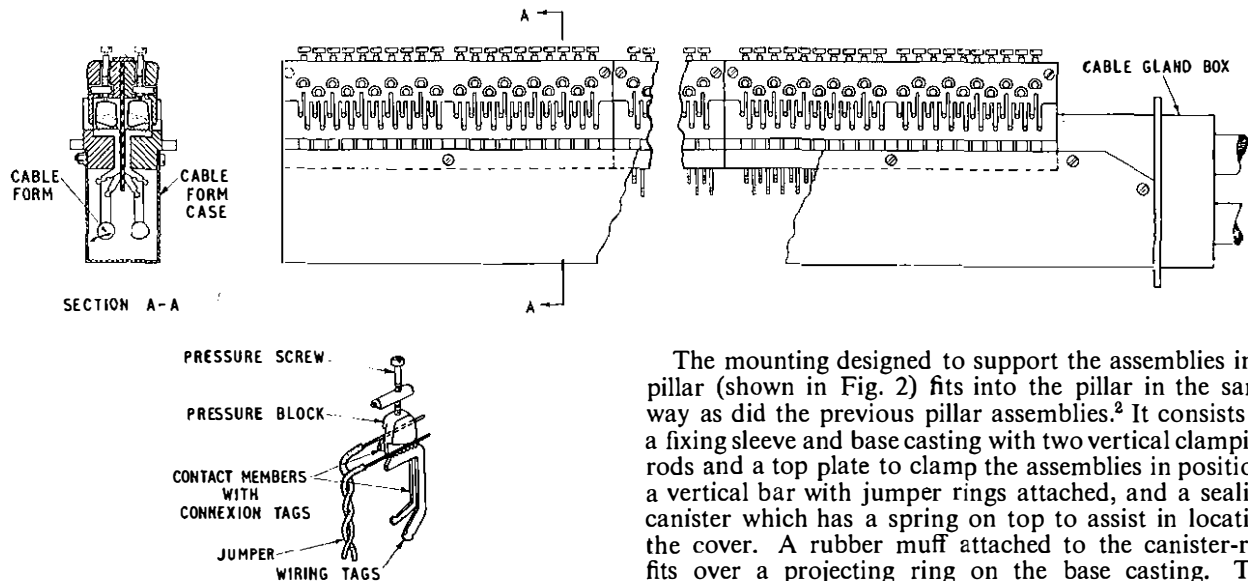

FIG. 1—NEW CROSS-CONNEXION ASSEMBLY

an enclosed-type connexion strip was decided upon.

By dispensing with the guide and label blocks of the 20 + 20 pair strip previously used, and by mounting five exchange-side and five distribution-side 20-pair mouldings on thin plastic strips, a 100 + 100 pair connexion strip half an inch narrower than the earlier type was obtained. This also avoided any modification to the tools used for producing the mouldings. The method of cross-connecting circuits on these connexion strips is the same as on the previous 20 + 20 pair enclosed type.

To enable two 100 + 100 pair assemblies to be fitted in a pillar it was essential to keep the width and depth of the assemblies to a minimum. The requirement that a pillar should be capable of being equipped initially with either one or two assemblies but that if required the second assembly could be added later meant that some form of mounting would have to be fitted into the pillar to support the assemblies. The best arrangement was found to be to set the assemblies side by side at an angle of approximately 30° to each other, with the jumper rings at the back. This led to the decision to include the jumper rings and sealing canister with the mounting.

Description of Assembly and Associated Pillar Mounting

The new cross-connexion assembly is shown in Fig. 1. Where the cable tails enter the gland box at the bottom of the assembly they are secured by an expanding rubber gland. Above this, the cables are formed out and soldered to the wiring tags of the contacts in the connexion strip. The cable forms are enclosed in a mild-steel case to which the connexion strip and gland box are secured to ensure a rigid structure. The assembly is fitted with a 30ft loop of cable, one end of which is terminated on the exchange side of the connexion strip and the other on the distribution side. Prior to installing the assembly, the cable is cut to form two separate tails to suit the layout of the jointing chamber. A flange is provided on the gland-box to seal the bottom of the assembly when it is fitted in a pillar mounting, and two hank bushes riveted inside the back of the cable-form cover enable a suitable mounting bar complete with jumper rings to be attached to the assembly to support it if it is used in a standard cross-connexion cabinet.

The mounting designed to support the assemblies in a pillar (shown in Fig. 2) fits into the pillar in the same way as did the previous pillar assemblies.² It consists of a fixing sleeve and base casting with two vertical clamping rods and a top plate to clamp the assemblies in position, a vertical bar with jumper rings attached, and a sealing canister which has a spring on top to assist in locating the cover. A rubber muff attached to the canister-rim fits over a projecting ring on the base casting. The canister is sealed by tightening a clip fitted around the lower edge of the rubber muff. The base of the casting has two oval holes into each of which fits the lower portion of an assembly gland box, after the cable tails have been passed through to the jointing chamber, via the connecting bend. Rubber gaskets are attached to the edges of these openings in the base casting, against which the flange on the assembly is pressed by the pressure exerted via the clamping rods and the top plate. The interior of the mounting is thus isolated from the interior of the pillar base and the duct line. Where only one assembly is installed initially the second opening in the base casting is sealed by clamping a small oval-shaped plate on to the rubber gasket. When required, this plate can be removed and a second assembly installed without disturbing the existing one. Fig. 3 shows pillar mountings equipped with one assembly and with two assemblies.

² EDWARDS, J. J. and HARDING, J. P. Flexibility Units for Local Line Networks. *P.O.E.E.J.*, Vol. 39, p. 100, Oct. 1946.

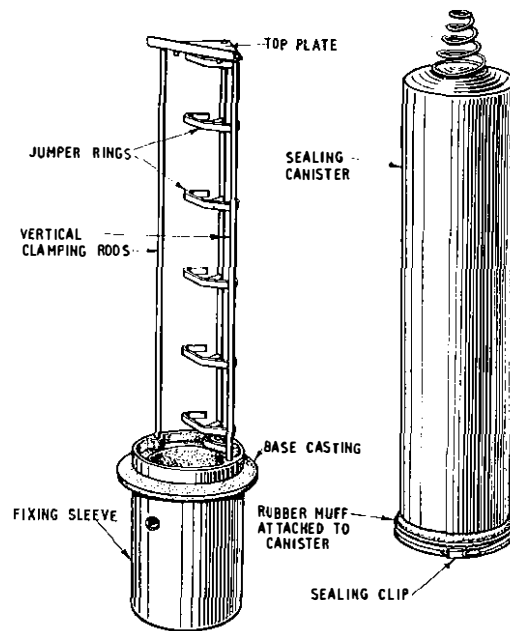

FIG. 2—PILLAR MOUNTINGS FOR ASSEMBLIES

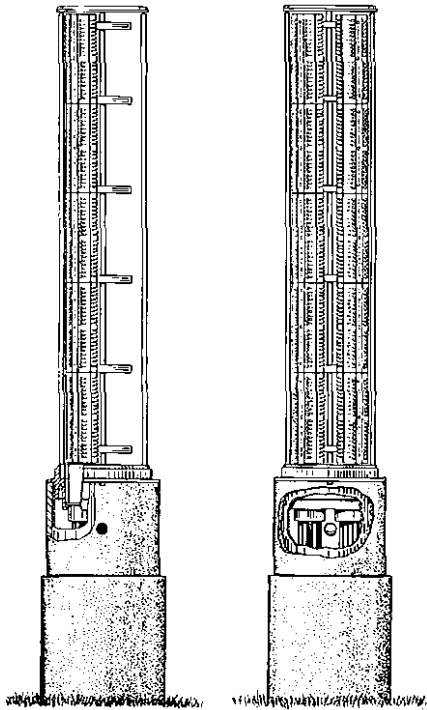

FIG. 3—PILLAR MOUNTINGS EQUIPPED WITH ASSEMBLIES

Packing of Assembly

The new assembly weighs approximately 25 lb, and the special packing cases required to protect the lead-sheathed cable tails of earlier types of assembly can be dispensed with because the p.v.c.-sheathed cable tails are less vulnerable. Instead, a flat fibre-board carton has been adopted, and the assembly can be stored in this until it is installed. Within this pack the strip-connexion portion of the assembly is enclosed in a polythene bag to exclude dust and moisture.

USE OF THE NEW ASSEMBLY IN CABINETS

The new-type assemblies are also being adopted for use in cabinets, and a mounting has been designed which enables the assembly to be fitted in a cabinet (Fig. 4). This mounting consists of a vertical bar with jumper rings attached and two lugs to enable it to be fixed to an assembly by means of two screws. Brackets at each end of the vertical bar allow the mounting to be hooked over and clamped to the transverse assembly-support bars provided in cabinets. The mounting has been designed to support the new type of assembly in both new cabinets and in existing cabinets already partially equipped with earlier types of assembly. In new cabinets full advantage

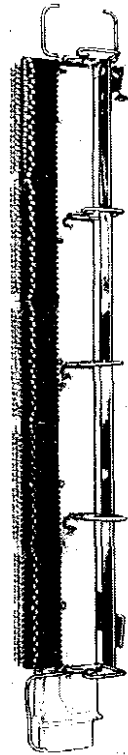

FIG. 4—ASSEMBLY WITH MOUNTING FOR USE IN CABINET

of the new assembly can be taken by setting the transverse bars further back in the cabinet to improve access to the interior of the cabinet base. This allows easier sealing of the cable tails at the point where they enter the connecting bends.

In the larger cross-connexion cabinets advantage is being taken of the reduced width of the new assemblies by so placing them that the centre bar against which the doors close does not restrict cross-connecting operations, thus eliminating the need to remove this bar when carrying out such work.

CONCLUSION

A new design of pillar assembly, which will enable the terminating capacity of a pillar to be increased to 200 pairs when fully equipped, has been developed. Suitable mountings have been designed which enable the assembly to be installed in both cabinets and pillars, thus making it possible to use a common design of assembly. Field trials of the new-type assemblies have proved satisfactory.

Book Received

"Industrial Electronics and Control." Second edition. R. G. Kloeffler. John Wiley & Sons, Inc., New York, and Chapman & Hall, Ltd., London. ix + 540 pp. 452 ill. 80s.

This second edition differs from its predecessor in that it approaches the electronic theory of rectification, amplification, and oscillation through solid-state theory rather than

by way of the vacuum and gaseous tubes. The book has been written to give engineering students a survey of the theory and application of electronics in industry, and to meet the requirements of students in mechanical, chemical and industrial engineering who desire a knowledge of industrial-electronic applications; no attempt has been made to provide a quantitative approach to the design of circuits. Throughout the book American symbols have been used, and where illustrations are given of components and equipment these devices are of American manufacture.

Four New Engineering Vehicles

A. W. THOMAS, A.M.I.Mech.E., A.F.R.Ae.S., and E. R. COLLINGS†

U.D.C. 629.114.4

Recent designs of commercial vehicles have been adapted for Post Office engineering use. Two of the vehicles described are standard types of van requiring only slight modification to suit them for engineering duties. The two larger vehicles dealt with have Post Office designed bodies mounted on standard commercial chassis. The new vehicles are compared with corresponding types at present in use.

INTRODUCTION

THE design of commercial vehicles is always changing to meet customers' requirements and to take advantage of developments in engineering and manufacturing processes. The transport requirements of Post Office engineering staff also change as more tele-communications plant is provided and new types of equipment are introduced. It is therefore desirable to consider periodically whether the types of vehicles already in use are adequate for their purpose. For this reason a committee consisting of Regional and Headquarters representatives was set up in 1958 to study engineering-transport requirements. Basically, the best value for money is obtained by modifying or adapting complete commercial vehicles to suit Post Office needs. For vehicles to be used by external gangs such adaptation is not possible, and special bodywork to meet Post Office requirements must be built on standard chassis.

In reviewing engineering-vehicle design, account must be taken of varying requirements for transporting men, tools, stores and equipment to carry out similar jobs. For example, the new 15 cwt Utility vehicle will meet most of the requirements for transporting two men and their tools and equipment, but in some areas a 25 cwt Utility vehicle may be required for similar duties, whilst in other areas a Morris Minor would suffice. The committee have therefore endeavoured to provide vehicles of different load capacities but having similar functions, leaving the final choice of vehicle to Regional and Area staff.

To avoid lengthy field trials with the larger coach-built vehicles, full-size models of body interiors were produced at the Central Repair Depot, Kidbrooke. Regional staffs were invited to view these models and comment on the layouts. Valuable suggestions were received and incorporated in the prototypes of the new 25 cwt and 30 cwt Utility vehicles. The British Motor Corporation (B.M.C.) then co-operated in building these bodies on the appropriate chassis and also produced for the committee's inspection a commercial model of their new Mini-Minor and also of their new 15 cwt van. Brief descriptions of the new vehicles are given in the following paragraphs, and the main features and dimensions are compared with the present corresponding types.

MORRIS MINI-VAN

The Morris Mini-Van is illustrated in Fig. 1. This recently introduced vehicle has been adapted for use as a 4½ cwt engineering van by the provision of metal bins in the load-carrying part of the body, this part being divided from the cab by an expanded-metal partition.

† Motor Transport Branch, E.-in-C.'s Office.



FIG. 1.—MORRIS MINI-VAN

The bins are modified versions of those used in the present Morris Minor Type 3 van. Arrangements are being made so that pruning and survey rods, and folding steps can be carried on the roof of the new van because its body is too short to enable them to be carried inside.

The appearance of the vehicle is extremely deceptive because, although the body space is slightly smaller than that of the Morris Minor, the cab portion is in fact bigger. Seating is provided for one passenger in addition to the driver, and the load capacity is 4½ cwt. It is intended that this vehicle should supersede the present Minor van in towns and other suitable areas where its smaller size, greater manoeuvrability and decreased fuel consumption are advantageous.

The design of the vehicle is most interesting as it

TABLE I
Comparison of Mini-Van and Present Minor Van

Vehicle	Minor Van	Mini-Van
Function	Transporting linemen, fitters, etc.	
Chassis type	½-ton	Mini-Van
Engine size	803 c.c.	848 c.c.
<i>Dimensions</i>	<i>ft in.</i>	<i>ft in.</i>
Overall length	12 0	10 9½
„ height	5 10	4 11½
„ width	5 0	4 7½
Interior length	4 4	4 1
„ height	3 7	3 0½
„ width	4 7	4 5
Turning Circle	32 0	29 6
<i>Carrying capacity:</i>		
Volume (ft³)	65	45
Load, excluding passengers (cwt)	5	4½
Gross moving weight (cwt)	23	19½
Seats in cab	2	2
Ladder carried	One 8 ft (extending) ladder	
Steps carried	One pair	



FIG. 2—15 CWT UTILITY VAN

incorporates the following major departures from conventional practice:

(a) The 4-cylinder 848 c.c engine is mounted transversely in the vehicle.

(b) The engine, gearbox and differential-transmission gears are all contained within a common casing and are lubricated by the engine oil. This reduces the number of lubrication points of these major items from three to one.

(c) Front-wheel drive is used.

(d) Independent rubber suspension is provided for all road wheels.

The engine and transmission-unit with radiator and complete front-suspension assembly are carried on a sub-frame which is bolted to the main body structure. Thus, the complete unit can be removed for overhaul by releasing four bolts and detaching the various linkages.

The new Mini-Van and the present Minor van are compared in Table 1.

15 CWT UTILITY VAN

The B.M.C. series J2 standard van with a 1,500 c.c. petrol engine has been modified so that it can transport the tools and stores for working parties of two men. It has a payload of 15 cwt and will serve as a replacement for the existing 10 cwt van. It will also carry out the lighter duties now performed by the 1-ton Utility vehicle. The new van is shown in Fig. 2.

Racks and bins are provided behind a partition separating the van body from the cab. The standard metal roof is replaced by a translucent roof of fibre glass, primarily to give more light to the interior of the vehicle, but advantage was also taken of this change to increase the internal headroom by 3½ in.

The ladder carrier on the roof is designed to take a 14 ft extending ladder. To avoid loading the fibre-glass roof, the carrier is supported by metal brackets fixed to the metal sides of the vehicle.

The single-leaf rear door of the standard van has been changed to a double-leaf rear door made in fibre-

glass material. Less space is required behind the vehicle to open the double-leaf door.

By mounting the engine to the rear of the driver's seat, which is situated between the front wheels, it has been possible to place the cab doors in front of the wheel

TABLE 2

Comparison of Present 10 cwt Van and New 15 cwt Utility Van

Vehicle	10 cwt Van	15 cwt Van
Function	Transporting small parties of men engaged on overhead or underground work	
Chassis type (maker's code)	JB	J2
Engine size Fuel	1,500 c.c petrol	1,500 c.c petrol
<i>Dimensions:</i> Overall length	ft in.	ft in.
„ height	7 0	8 3½
„ width	5 8	6 1¼
Interior length	7 0	9 0
„ height	4 6½	5 1
„ width	4 10	5 7
Turning circle	35 0	37 0
<i>Carrying capacity:</i> Volume (ft³)	140	200
Load, excluding passengers (cwt)	10	15
Gross moving load of vehicle (cwt)	40	44½
Towing capacity (cwt)	Trailer tool-cart only	10
Seats in cab	2	2
Ladders carried	One 8 ft (extending)	One 14 ft and one 8ft (extending)
Steps carried	One pair	One pair



FIG. 3—25 CWT UTILITY VAN

arches so that improved access to the cab is given compared with the existing 10 cwt van.

The new 15 cwt van and the present 10 cwt van are compared in Table 2.

25 CWT UTILITY VAN

The present type of 1-ton Utility vehicle will be superseded by a vehicle based on the new B.M.C. 2-ton forward-control chassis fitted with a 3.4-litre diesel engine. A Post Office designed body permitting a payload of 25 cwt and a towing capacity of 35 cwt will be mounted on this chassis (Fig. 3).

The vehicle is of the conventional forward-control type. The cab, which can carry four men, has a wrap-round windscreen with low forward corner-windows to give the driver improved visibility. Vertical as well as horizontal movement of the driver's seat is provided.

The body is a Luton-head type (i.e. with carrying capacity above the cab) of integral construction, and, with this type of body, ladder apertures at the front are unnecessary. The usual shelving and racks are provided inside the van. On the off-side a shelf supports a 14 ft extending ladder, which projects above the cab. To prevent water dripping on to the driver (if a ladder is stowed in a wet condition) a protective canvas apron is provided. Lockers are fitted for the crew's personal belongings.

30 CWT UTILITY VAN

The new 30 cwt Utility van is shown in Fig. 4. This vehicle was designed as a replacement for the obsolescent 30 cwt Utility vehicle. A Post Office designed body has been mounted on the B.M.C. 3-ton forward-control chassis, which, like the 2-ton chassis, has a 3.4-litre diesel engine. A double cab is provided with seats and personal lockers for five men. A folding table is also fitted in the cab, which has a wrap-round windscreen and low forward corner-windows similar to those on the new 25 cwt van.

In the body of the vehicle, shelves and racks are provided for stores and ladders. Bolsters capable of supporting two 32 ft medium poles or four 26 ft light poles are also fitted. To enable poles, ladders or other long items to project through the front of the body, trapdoors are fitted. To prevent rain entering the body the trapdoors are provided with protective canvas aprons.

The new 25 cwt and 30 cwt Utility vehicles and the present 1-ton Utility and 2-ton General Utility vehicles are compared in Table 3.

ACKNOWLEDGEMENT

The authors wish to express their

TABLE 3
Comparison of New 25 cwt and 30 cwt Utility Vehicles and Present 1-ton Utility and 2-ton General Utility Vehicles

Vehicle	Present 1-ton Utility	New 25 cwt Utility	New 30 cwt Utility	Present 2-ton General Utility
Function	Transporting external gangs on overhead and underground duties			
Chassis type (maker's code)	LC5	FG(2T)	FG(3T)	QXM
Engine size	2,199 c.c.	3,400 c.c.	3,400 c.c.	4,752 c.c.
Fuel	petrol	diesel	diesel	petrol
<i>Dimensions:</i>	<i>ft.</i> <i>in.</i>	<i>ft.</i> <i>in.</i>	<i>ft.</i> <i>in.</i>	<i>ft.</i> <i>in.</i>
Overall length	16 6	16 7½	19 0	20 6
.. height	8 9	9 3	9 4	9 8
.. width	6 6	7 0½	7 0½	7 5
Interior length	7 10	7 7 (near side) 9 4 (off side)	9 8½	10 7
Interior height	5 11	6 3	6 3	6 4
.. width	6 3½	6 4½	6 5	6 7
Turning circle	45 0	40 0	45 0	50 0
<i>Carrying capacity:</i>				
Volume (ft³)	240	300	380	430
Weight, excluding passengers (cwt)	20	25	30	30
Gross moving load of vehicle (cwt)	65	84	110	115
Towing capacity (cwt)	35	35	35	45 (trailers fitted with over-run brakes) 100 (trailers fitted with vacuum brakes)
Seats in cab	2	4	5	5

appreciation to their colleagues in the Central Repair Depot, Kidbrooke, who built the full-size models of the interiors of the larger vehicles, and to the British Motor Corporation who built the prototypes of these vehicles.



FIG. 4—30 CWT UTILITY VAN

International Symposium on Data Transmission, Delft, 1960

U.D.C. 061.3:621.398:681.142

AS the size, speed and expense of modern computers grow more formidable every year, it has become increasingly advantageous for organizations to have one central computing centre and to feed data from out-stations over telegraph and telephone circuits to the computer for processing. It was an interest in this aspect of data transmission that attracted more than 500 engineers to Delft, Holland, for a symposium organized by the Benelux Section of the Institute of Radio Engineers on 19–21 September 1960; among them were representatives of the Post Office Engineering Department and H.M. Treasury Automatic Data Processing Technical Support Unit. About 25 papers were read by American, British, Dutch and French authors, and covered such subjects as Error Rates over Telephone Lines, Data Transmission over Radio Links, Modulation and Demodulation Systems, and Data Transmission Systems. Some of the more important points that were brought out at the symposium are described briefly below.

Error Rates

Many of the papers read reported errors as found on existing telephone networks in Europe and the United States. Dr. W. R. Bennett made the observation that "the telephone networks were no more designed for the transmission of data than Mount Everest was designed for climbing." It was obvious that users expected errors and that the operating organizations, although interested in finding the causes, were doubtful about their ability to improve greatly the performance of the circuits.

There were differences of opinion as to the best measure of errors. Various authors quoted: error-free minutes; character error rates in terms of errors per x characters or the number of characters per error; and block error rates, expressed as blocks in error per x blocks. The actual error rates vary with the type of modulation used, the signal/noise ratio at which the circuit is operated, the circuit length and many other factors. All speakers noted that the performance achieved was very variable with time and that most trouble was from impulsive-type noise. Many of the figures quoted averaged about 1 error in 10^4 characters for switched connexions and 1 error in 10^6 characters for private wires.

Causes of Errors

Mr. Enticknap's (M.I.T.*) paper contained many copies of oscilloscope traces showing the types of noise pulse that had caused errors, and these were classified according to the type of equipment over which the circuits were routed. Examples were given from loaded audio cable circuits, carrier in symmetrical-pair cable and s.h.f. radio links in the U.S.A. The causes of the noise bursts were, however, unknown. Mr. Wright (S.T.C.) demonstrated with a tape recorder the types of noise that cause errors in data transmission.

Maintenance staff were blamed by some authors for many of the errors. Comparisons were made of the

performance of data circuits over the Hawaii submarine cable and an equivalent inland circuit—also the pattern of changing error rates with time of day were used as evidence to prove that the cause may have been working parties. It was pointed out in the discussion that similar effects could have other causes. The graphs of error rate against time of day were similar in form to the traffic load on the network, and the general pattern of human activity. Everyone working on circuits that carry data would do well to remember that each break or noise burst of $\frac{1}{2}$ ms can cause an error in transmission.

Data Transmission Systems

In addition to the many papers concerned with general problems in data transmission, such as the error rates mentioned above, there were references at the Delft Symposium to specific data transmission systems. Some of these were new commercial models that are expected to be taking traffic in the next few months, and had papers devoted to their description; others were mentioned incidentally in papers concerned principally with the measurement of error rates. It must be emphasized that the systems mentioned below are by no means complete, for many companies in various countries are now producing or developing data transmission equipment.

Two systems described at Delft had several features in common. Both will come into operation in the U.S.A. in mid-1961, and are intended to serve booking agents for airline companies. An outlying office receives a request for a journey to be booked between two points on a certain day; this journey may be quite complicated, necessitating several changes at intermediate airfields between different plane flights that are more or less heavily booked. The agent sets up this request on a keyboard and this is transmitted to a central computer which has a backing file containing all reservations on all flights that have been made to date. The computer consults the file of bookings and sends back to the agent the best possible way of travelling between the two points on the specified day. The whole cycle of inquiry and reply takes only a few seconds.

One system for achieving this is the I.B.M.† "Sabre" system, in which the computer is sited in New York and a high-speed data system extends from the computer across the continent to the west coast; this route is interrupted at about 30 intermediate points by "Mulcoms," and each of these can be linked to up to 30 agents' offices by normal low-speed teletype lines. Inquiries received at each Mulcom from its associated agents are then scanned in turn by the computer, starting from the most remote station and working towards New York, and the appropriate reply is returned.

A similar service is provided by a Philips system, which differs from the I.B.M. scheme in that the computer is almost in the centre of the U.S.A., in Denver, and is linked to a number of stations, called "concentrators," by a high-speed data system in the form of two loops, one covering the east, and other the west, of the country. Once again, each concentrator can be linked to a number of agents' offices by standard teletype lines, but in this case requests from the offices go first to the

* M.I.T.—Massachusetts Institute of Technology.

† I.B.M.—International Business Machines Corporation.

nearest concentrator at low-speed and are then handed on from concentrator to concentrator until they reach the computer, choosing the shortest way round the loop.

Another system described was used for the transmission of radar plots; this worked at a speed of 750 bauds and employed a 1,500 c/s carrier, phase modulated 180° by a mark digit but unaltered by a space digit.

Many types of modulation are used in data transmission systems: straightforward amplitude modulation, asymmetric-sideband amplitude modulation, frequency shift, and phase modulation—all appear in different systems, and each has its champions who claim its superiority over the others. Some work in the Bell Telephone Laboratories was described in which a complete data transmission system was simulated by an analogue computer and various types of modulation were compared under similar noise interference conditions. The tests showed phase modulation to be the best, but the improvement over other types of modulation was marginal and it is possible that technical considerations would prevent the full improvement from being realized.

Error Detection and Correction

In order to eliminate errors in transmission of data, provision must be made for, firstly, automatically detecting the errors and, secondly, correcting the errors. While papers at this symposium reviewed methods of detecting errors, no engineered data transmission system employing error correction was described; this reflects the present position on data transmission—lots of ideas but no final solutions.

There are several methods of error detection, namely:

- (a) Decision feedback.
- (b) Error-detecting codes.
- (c) Loop check.

“Decision feedback,” which is used commercially on a simple type of radio telegraph system, provides for recognition at the detector of the receiving equipment not only of two conditions, Mark and Space, but also of a third condition, “it is not known with sufficient probability if the signal is Mark or Space.” This is, therefore, an “error” condition and can be used to request a repetition of the faulty signal.

Much interest has recently been shown in the use of “error detecting codes;” for example, in the Van Duuren automatic error-correction system* used on radio telegraph circuits the ordinary 5-unit teleprinter code is translated to combinations formed by a 7-unit code such that genuine combinations have a ratio of 3 mark elements to 4 space elements. Thus any mutilation which upsets the 3:4 ratio can be detected as an error and a repetition called for automatically. Since the transmission of data involves the use of 2-condition signals representing say “One” instead of “Mark” and “Zero” instead of “Space,” codes may be used to protect data in transmission, by adding suitable checking digits to a group of digits to give, say, an even number of “Ones.” The check digits are termed “redundant” since they do not convey data. By providing elaborate checking systems, e.g. vertical and diagonal parity checks on a block of 500 bits, a very high proportion of errors may be detected,

* CROSDALE, A. C. Teleprinting over Long-Distance Radio Links. *P.O.E.E.J.*, Vol. 51, p. 219, Oct. 1958.

† CLINCH, C. E. E. Time Assignment Speech Interpolation (T.A.S.I.). *P.O.E.E.J.*, Vol. 53, p. 197, Oct. 1960.

employing a redundancy of about 5 per cent. Horizontal parity checks are less efficient because the parity bit is transmitted closely after the data.

A “loop check” method of error detection may be employed when a return circuit (as in duplex telegraphy) is available (usually without extra cost). The signal at the receiver is processed but a “leak” signal is fed back on the return circuit to the transmitter where it is compared element by element with the original signal. The errors are therefore determined at the sending end, whereas (a) and (b) provide for detection of the errors at the receiving end.

Having detected the error the problem is how to correct it, whether manually by re-sending the data, which may suffice for telegraph circuits, or by automatic means. It would be of advantage if the errors were corrected as they were received, and ingenious codes have been invented which, in fact, do correct limited bursts of errors. For example, a forward error-correcting code was described which has a cyclic method of coding and will correct up to six errors in a burst, though employing a fairly high percentage of redundancy. The attraction of error-correcting codes is the ability to keep transmitting the data without requiring repetitions, which would involve the turn-round time of echo-suppressors and possibly the switching time of T.A.S.I.‡ on a switched telephone circuit. The disadvantage is that the nature of errors in transmission is so varied that some errors may not be corrected by the code and hence, for a very reliable service, a re-transmission method may have to be added. It should be noted that the redundancy of the error-correcting code reduces the information rate all the time, whereas with a method employing error-correction by repetition the redundancy is very low when the circuit is good and only increases as the error rate increases.

It seems likely that, for the highest accuracy of transmission of data, correction of errors will have to be by repetition; that is, by re-transmitting the block containing the error. Two methods are possible:

(i) Transmit blocks of data continuously in the forward direction until an error is detected. An error signal is then returned on a low-speed control channel, in the backward direction, to call for repetition of the faulty block. To cater for the case where transmission of a second block has started while the error signal is being returned, a second block must be repeated.

(ii) A block of data may be transmitted, followed by a pause to obtain either a confirmation or error signal from the receiver before transmitting another block. This method results in a waste of circuit time equal to the loop propagation time plus the return signal time for each data block, but in practice it may be simpler than (i).

Both methods require storage at the receiver to prevent a block being released before it has been checked for transmission errors.

Conclusion

In conclusion, it can be said that the Delft Symposium gave an invaluable opportunity for many experts to pool their information. The conference cannot fail to have stimulated developments in this rapidly-developing subject, and to have shown which lines of inquiry are unsuitable for further investigation.

C. E. E. C.
A. C. C.
D. W.

Ductile Permanent-Magnet Materials

G. W. EASTWOOD, B.Sc., A.Inst.P.†

U.D.C. 621.318.22

Soft magnetic materials used for transformers and relays are mechanically soft enough to be easily drilled, punched and bent, but permanent-magnet materials are usually so hard that they can only be worked by grinding. Certain alloys, however, have been found which combine good magnetic hardness with ductility. They can thus be drawn into wire and rolled into tape. The alloys are finding increasing use as durable recording media, for making small permanent magnets by stamping and for a variety of other purposes.

PERMANENT-MAGNET MATERIALS

THE magnetic properties of most magnetic materials are closely connected with their mechanical properties; in fact, part of the terminology arises from this connexion. Pure iron is quite soft mechanically and is also quite easily magnetized, the coercivity usually being of the order of 1 oersted (0.8×10^2 amp/metre). Similarly many alloys of iron, nickel and cobalt with other materials are both easily magnetized and readily deformed; they can be processed by rolling either hot or cold. These materials may be useful either because of high initial permeability (silicon-iron, Mumetal, Radiometal, Rhometal, Nilo-Mag 771, Sanbold N.A.76 and various Permalloys) or because they can be made to have nearly rectangular hysteresis loops (H.C.R., Permenorm 5000Z, Permalloy F, Nilo-Mag 641), but they all have coercivities less than 10 oersteds (8×10^2 amp/metre) and, for the most useful materials, less than 1 oersted (0.8×10^2 amp/metre). All are, therefore, regarded as being magnetically soft.

On the other hand, magnetic materials which are mechanically hard and brittle are also difficult to magnetize, and correspondingly difficult to demagnetize. The classic example of a hard magnetic material is high-carbon steel, which derives both mechanical and magnetic hardness by the precipitation of martensite. The modern high-performance alloys such as Alnico are believed to harden by the segregation of iron to form iron-rich regions which strain the crystal lattice; the material is then mechanically hard because the distorted crystal planes cannot easily slip, and it is magnetically hard because the domain walls are anchored by the inhomogeneities and because the islands of iron-rich material have an intrinsically high coercivity.¹ These alloys are extremely hard and brittle and cannot usually be drilled or machined except by grinding. In order to get over this difficulty, small magnets of intricate shape are now often made by powder metallurgy; the alloy is prepared by mixing the finely-powdered constituents and pressing the mixture to the shape of the finished part. The pressings are then sintered in hydrogen at temperatures up to 1,400°C, when the individual particles diffuse and give a uniform alloy. Some shrinkage takes place during sintering but this can be allowed for in the design of the die. The magnetic properties are not quite so good as those of cast alloy, but the process is very satisfactory for long production runs of small parts where the ease of fabrication offsets the higher cost of materials and the cost of tooling.

Permanent magnets are often required to produce the greatest possible field in an air-gap. It can be shown that

for a given volume of material the magnet should be so proportioned that the product of the induction in it and the demagnetizing field to which it is subjected is a maximum. This product, $(BH)_{max}$, varies less from alloy to alloy than do the coercivity and remanence; its value may reach 1.2×10^6 gauss-oersteds ($0.8-1.6 \times 10^4$ amp-weber/metre³) for the isotropic materials and up to 11×10^6 gauss-oersteds (8.8×10^4 amp-weber/metre³) for the best anisotropic ones.

The useful hard materials have coercivities of a few hundreds of oersteds and remanences up to 8,000 gauss (0.8 weber/metre²) for isotropic materials. For anisotropic materials which have been heat treated in a magnetic field the remanence may be as high as 13,000 gauss (1.3 weber/metre²).

DUCTILE PERMANENT-MAGNETIC MATERIALS

The correlation between magnetic and mechanical hardness is not absolute and there are considerable variations in degree. In particular, certain alloys which harden by precipitating a second phase are soft enough to be mechanically worked although their magnetic properties are comparable with those of the isotropic diffusion-hardening alloys. Alloys of iron with molybdenum, tungsten, beryllium or titanium can be hardened magnetically in this way, though the properties obtained are not good enough to be commercially useful. By adding a third constituent, however, a number of very useful materials have been obtained.

The most important of these contains about 20 per cent of iron, 20 per cent of nickel and 60 per cent of copper. It is known as Cunife² in the U.S.A. and as Magnetoflex 20 in Germany. Below a temperature of about 750°C the alloy contains two phases in equilibrium, though the rate of reaching equilibrium is very slow at the lower temperatures. The usual process is to quench the alloy from 1,000°C, which freezes-in the single phase and gives a quite soft material. The alloy is then heated to 600°C when the copper-poor and copper-rich phases separate. The precipitated alloy is found to be very hard magnetically but still relatively soft mechanically, and can be rolled, drilled, punched and bent. This unusual combination of properties is useful in a number of specialized fields. Cunico (copper-nickel-cobalt) and Vicalloy (iron-cobalt-vanadium) have similar properties but they are rather hard in the precipitated state. This, and the high cost of cobalt and vanadium, make them less attractive except where the higher coercivity of Cunico or higher remanence of Vicalloy are specially required.

Cunife is made in the U.S.A. by vacuum-melting, and a similar alloy has recently been made in this country by the powder-metallurgy process. The method was developed at the Post Office Research Station in collaboration with the Mond Nickel Co. as a means of making experimental samples of soft materials, with precisely known composition, which were never melted and so were never in contact with a furnace lining or slag from which impurities could be picked up.³ The constituent metal powders are intimately mixed in the correct proportions and pressed into a rectangular block, which is

† Post Office Research Station.

then sintered in hydrogen at a temperature of about 1,300°C. The compacted material is then cold-rolled with suitable intermediate annealing.

For production of Cunife-type material the strip is rolled until it is 10–20 times the required final thickness and is then heat treated in hydrogen for 3 hours at 1,100°C. Next, it is gas-quenched to give the soft single-phase alloy, and then rolled without further annealing to the final thickness required. This considerable cold reduction of 90–95 percent produces some hardening, and the precipitation of the second phase is completed by a final heat treatment at 600°C for 3 hours. This last process is often called “aging” since precipitation hardening was first observed as an increase in hardness of certain alloys with time. The strip is flexible and resilient, and it can be cut, bent or drilled without difficulty.

The properties of Cunife and other materials are compared in the table. The properties quoted in the table for the British material apply to strip between 0.013 in. and 0.0003 in. in thickness. The alloy made by powder metallurgy is now commercially available and coercivities up to 600 oersteds (4.8×10^4 amp/metre), measured at 50 c/s, have been obtained. Vicalloy, made by vacuum melting, is also produced in the United Kingdom.

USES OF CUNIFE

Cunife finds its main application as a medium for recording data. Since its surface is very hard (unlike that of oxide-covered tape) it is possible to run the transducer for long periods in continuous or intermittent contact with the tape without causing damage. Knight and Circuit have recently described a file drum¹ which stores 15,000,000 bits on a drum 15 in. in diameter and 14 in. in height. The alloy is applied to the drum as a close helix of tape, 0.1 in. wide and 0.03 in. thick, which is stuck down with epoxy resin and lapped flat to within 1 micro-inch r.m.s. The transducer heads contain ferrite pole-pieces having a 0.0003 in. gap spaced by beryllium-copper tape, and they are normally separated from the drum by a thin film of oil. When starting and stopping, the head is in contact with the drum, and it is so pivoted that the wear takes place on an unimportant corner away from the gap. The metal is not damaged by this treatment although a conventional oxide layer would

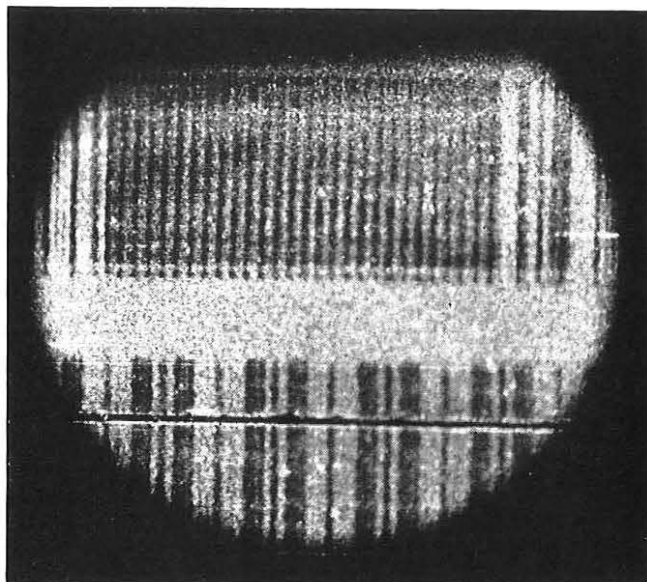

The recorded tracks are 0.030 in. wide and about 1,000 digits/inch can be recorded. The black line across the lower track is a joint between adjacent turns of tape; it is clear that joints do not interfere with the digits in any way. The digits have been made visible by the “Bitter figure” technique used for observing magnetic domains.

RECORDED TRACKS ON CUNIFE

soon wear away. The recording uses a balanced code so that successive superimposed digits do not cause the alloy to be magnetized to such a depth that it cannot subsequently be erased, and also so that transformer coupling can be used.

It might be thought that the joints between adjacent turns of the helix would interfere with digits recorded over them but it will be seen from the photograph that the recorded digits cross the join without being affected in any way.

Another interesting application is for the indicating needles in a pulse-counting circuit developed by the Atomic Energy Research Establishment. The pulses are counted by stepping a shift-register of 10 cores, each core consisting of a film of 82/18 nickel-iron, 1,800Å thick, plated on a copper rod 3 cm long. Each core, when magnetized, has free poles at its ends though it is sufficiently long to have a small demagnetizing factor.

Properties of Some Ductile and Other Permanent-Magnet Materials

Alloy	Composition (Percentage)	Coercivity		Remanence		$(BH)_{max}$		Hardness Vickers Pyramid Number			Remarks
		Oersted	Amp/metre	Gauss	Weber/metre ²	Gauss-Oersted	Amp-Weber/metre ³	Cast	Cold-rolled	Hardened	
Cunife-type alloy (British)	60Cu, 20Ni, 20Fe	450-500	$3.6-4 \times 10^4$	5,000-6,000	0.5-0.6	1.6×10^6	1.3×10^4	—	—	200	Machineable
Cunife 1	60Cu, 20Ni, 20Fe	550	4.4×10^4	5,400	0.54	1.7×10^6	1.35×10^4	135	—	200	Machineable
Cunife 2	50Cu, 20Ni, 27.5Fe, 2.5Co	260	2.1×10^4	7,300	0.73	0.8×10^6	0.64×10^4	135	—	200	Machineable
Magnetoflex 20	60Cu, 20Ni, 20Fe	420	3.3×10^4	5,200	0.52	0.9×10^6	0.72×10^4	—	160	215	Machineable
Cunico 1	50Cu, 21Ni, 29Co	660	5.3×10^4	3,400	0.34	0.8×10^6	0.64×10^4	590	—	690	Machineable before hardening
Vicalloy	52Co, 38Fe, 10V	300	2.4×10^4	9,000	0.9	1.0×10^6	0.8×10^4	300	400	745	Machineable before hardening
Magnetoflex 35	52Co, 35Fe, 13V	400	3.2×10^4	8,500	0.85	1.8×10^6	1.45×10^4	—	450	900	Machineable before hardening
Alcomax II	8Al, 21Co, 11Ni, 55.5Fe, 4.5Cu	575	4.6×10^4	12,400	1.24	4.3×10^6	3.5×10^4	590	—	650	Magnetically annealed. Brittle
Alnico IV	12Al, 27Ni, 5Co, 56Fe	660	5.3×10^4	6,000	0.6	1.3×10^6	1.0×10^4	590	—	600	Brittle

The cores are placed round a cylinder, parallel to its axis, and a compass needle in the plane of the ends of the cylinder points to the one core whose magnetization is opposite to that of the other nine. In fact, an astatic pair of needles is used with one at each end of the cylinder; the effect of the cores is thus doubled and that of the earth's field cancelled. The great virtue of this method of display is that once the core has been set no power is needed to maintain the indication, which persists even when the power supply is cut off. It is, therefore, very suitable for battery-driven equipment.

Several watt-hour meters have been described in which most of the pivot friction is eliminated by using permanent magnets to support the rotor. The only remaining friction is caused by a locating pin. Both Cunife⁵ and Cunico^{6,7} have been used for the supporting magnets.

Small magnetic parts can readily be stamped from Cunife strip or bent from wire.^{8,9} Cooter and Mundy have discussed the drawing of wire down to 0.005 in.,¹⁰ and strip as thin as 0.0003 in. has been made at the Post Office Research Station.

Strip made by heavy cold rolling is markedly anisotropic, having its best properties along the rolling direction; this makes it undesirable to use stampings in which the flux would have to travel across the rolling direction. However, it is possible that isotropic material, perhaps of lower performance, could be made if it were required.

ACKNOWLEDGEMENTS

The author wishes to thank Mr. C. Gordon Smith of

the Mond Nickel Co., Ltd., and Mr. E. M. Bradley and Dr. B. Steptoe of International Computers and Tabulators, Ltd., for interesting discussions on the applications of Cunife-type alloy. He is also indebted to Mr. E. V. Walker for information on the powder-metallurgy process. The photograph was supplied by International Computers and Tabulators, Ltd., to whom acknowledgement is made.

References

- ¹ HOSELTZ, K. *Ferromagnetic Properties of Metals and Alloys* (Oxford University Press, 1952), p. 256.
- ² BOZORTH, R. *Ferromagnetism* (Van Nostrand, 1951), p. 396.
- ³ RICHARDS, C. E., WALKER, E. V., and LYNCH, A. C. An Experimental Study of High-permeability Nickel-iron Alloys. *Proceedings I.E.E.*, Paper No. 2136M, 1956 (Vol. 104, Part B, p. 343).
- ⁴ KNIGHT, L., and CIRCUIT, M. P. A High-Density File Drum as a Computer Store. *Journal of the British Institution of Radio Engineers*, Vol. 20, p. 41, 1960.
- ⁵ Lifetime Bearings in New Meter. *Machine Design*, Vol. 20, p. 143, 1948.
- ⁶ TREKELL, H. F., MENDELSON, L. I., and WRIGHT, J. H. Magnetic Suspension of Watt-hour Meter Rotor. *Transactions of the American Institute of Electrical Engineers*, Vol. 67, Part II, p. 1, 180, 1948.
- ⁷ KINNAIRD, I. F. A New Watt-hour Meter. *Electrical Engineering*, Vol. 67, p. 627, 1948.
- ⁸ GOSS, J. H. Ductile Permanent Magnets Offer New Design Possibilities. *Product Engineering*, Vol. 17, p. 44, 1946.
- ⁹ REICHES, S. L., and INGLE, D. P. Magnetic Centring of Electrostatic Cathode-ray Tubes. *Electronics*, Vol. 25, p. 101, 1952.
- ¹⁰ COOTER, I. L., and MUNDY, R. E. Cunife Wire Magnets of Small Size. *Journal of Research of the National Bureau of Standards*, Vol. 59, p. 379, 1956.

Book Reviews

"Microwave Transmission." J. C. Slater. Dover Publications, Inc., New York, and Constable & Co., London. 309 pp. 76 ill. 12s.

This book was first published in 1942, in the early days of the Radiation Laboratory at the Massachusetts Institute of Technology when microwave techniques were almost unknown to telecommunications engineers. The author is Professor of Physics at the M.I.T. and, as with most teaching books that come from this Institute, he writes in a clear, fluent style that should appeal to students. Since Professor Slater's book was one of the early publications on microwave theory applied to transmission, much of its contents can now be found in more detail in later works. Nevertheless, some of his original ideas are still interesting; for example, he uses analogies between microwaves and other scientific fields, such as optics and acoustics, to convey a quick, firm impression, but he also takes care that the restrictions inherent in the analogies are made clear.

The author tends to stress the impedance concept of waveguide transmission, a weakness which many writers on waveguide have struggled to overcome; the situation arises from a desire to view the waveguide as a transmission line having closely similar properties to the more familiar types of lines. The concept fails because of the effects of dispersion and multi-modding; a more modern outlook does not try to consider waveguide in this way, but simply to take waveguide behaviour as it is revealed by electromagnetic field theory. It is interesting to note from this book that evolution of thought in the science of microwaves has already moved back to fundamentals, and that microwaves must now be considered as a separate and self-sufficient branch of transmission.

The book is intended for students rather than engineers as it is concerned almost entirely with theory rather than realization. It is, however, readable and would provide a very good background to examination work on microwave transmission.

I.P.O.E.E. Library No. 1636.

C. F. F. and W. A. R.

"A Course in Mathematical Analysis" (Three Volumes). Edouard Goursat. Translated by E. R. Hedrick. Dover Publications, Inc., N.Y., and Constable & Co., London. Vol. I: viii + 540 pp. 52 ill. Vol. II: x + 259 pp. 38 ill. Vol. III: viii + 300 pp. 40s. per set.

This paperbound republication of the translation of Prof. Goursat's two-volume "Course in Mathematical Analysis" presents to English readers a classic study of the fundamental principles of mathematical analysis. The work is based on the famous "Cours d'Analyse Mathematique" given by Prof. Goursat at the University of Paris at the turn of the century. Only a few changes have been made from the original French text. These were mostly slight changes of notation suggested by Prof. Goursat, who interested himself in the work of translation.

The first volume of this new Dover edition is an unabridged republication of the translation of the original first volume of Prof. Goursat's work. It gives a lucid exposition of the basic theory of differentiation and integration. There are many practical applications to geometrical problems. All the subjects a student meets in his first course on the calculus are clearly treated in this volume. In addition to the calculus the student will find an excellent introduction to the theory of infinite series.

In this Dover edition the second volume of Prof.

(Continued on p. 267)

Exhibition of Subscribers' Apparatus and Associated Equipment at 2-12 Gresham Street, London, E.C.2

U.D.C. 061.4:621.395.6

WITH the increasing specialization of many Branches of the Post Office Engineering Department it is becoming more difficult for the staff to keep abreast of current developments and practices. One suggestion for overcoming this difficulty has been that certain Branches should hold small exhibitions of current developments and practices in the entrance hall at 2-12 Gresham Street, the headquarters of the Engineering Department.

Following a display of new items of subscribers' apparatus for Chief Regional Engineers in May, 1960, it was suggested that this display could form the nucleus of a more general exhibition of recent developments in subscribers' apparatus and associated equipment with which the Subscribers' Apparatus and Miscellaneous Services Branch is concerned. The exhibition was held at 2-12 Gresham Street in July/August, 1960, the theme being the exploitation of new materials and techniques to provide more attractive and efficient equipment.

As shown in the general view of the exhibition from the rear of the hall (Fig. 1), a double-sided display panel was arranged along the centre line and backboards and benches were placed against each wall.

Telephone Instruments

Facing the main entrance (Fig. 2) was a table displaying the new table telephone (Telephone No. 706)¹ in its full range of black and six colours. On the centre display the apparatus required for an external extension Plan 7, using the latest telephone and plinth (Plan Set N 625),² was compared with the preceding design. The manner in which the 700-type telephones had been designed to



FIG. 2—THE NEW TABLE TELEPHONE

replace the 300-type telephones³ was demonstrated by the two basic Telephones No. 706 and No. 710⁴, with the full range of add-on units, and the 12 distinct 300-type telephones which they replace. The emphasis of this display was on the reduction in storage space and the flexibility resulting from the concept of two basic telephones with add-on units.

The historical development of the wall telephone was shown by arranging on an ascending diagonal the early wooden-box pattern (No. 121), two later designs with moulded cases (Telephones No. 311 and 321⁵) and the present interim design⁶ (an adaptation of the "706" table telephone) culminating in a question mark to signify



FIG. 1—GENERAL VIEW OF THE EXHIBITION

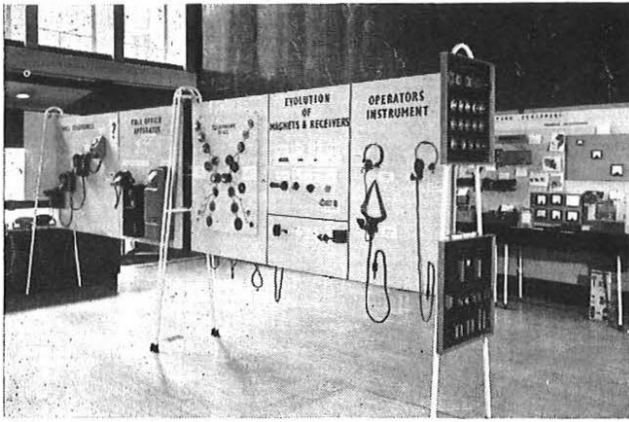

FIG. 3—WALL TELEPHONES, COIN-BOX TELEPHONE, OPERATORS' HEADSETS AND COMPONENTS

that a new wall telephone is being designed (Fig. 3). Next to this were mounted the current coin-collecting box with its separate telephone and the new self-contained pay-on-answer coin-box,⁷ which is being introduced in S.T.D. areas.

The main advantage of the new Dial No. 21⁸ over the earlier No. 12 dial is its simplified construction, the trigger-type mechanism being essentially the same. To demonstrate this advantage, components at successive stages of manufacture were compared (Fig. 3), the heavy drawn brass case versus the simple sub-chassis and moulded case, and the stainless-steel fingerplate and components versus the plastic fingerplate.

The effect of the improvements in magnetic alloys on the evolution of receivers was graphically displayed by the Bell Receiver No. 1A and Receivers, Inset, No. 1L, 2P and 4T with their associated magnets: a 3½ in. long horseshoe magnet of tungsten steel, a 1½ in. bar of cobalt steel, a ¾ in. bar of Alnico and a ¾ in. long Alcomax magnet. As the rocking-armature receiver⁹ (Receiver No. 4T) is a sealed capsule the components of a unit were displayed in an exploded view.

The one-piece light-weight headset for telephone operators (Headset No. 1)¹⁰ was compared with the heavy and clumsy two-piece headgear receiver and breastplate transmitter.

The prototype loudspeaking telephone (Loudspeaking Telephone No. 1), which was a working exhibit, proved a great attraction. By dialling a special number a recorded message could be received from an automatic telephone answering set or, alternatively, normal calls could be made by dialling over the local telephone network (e.g. TIM or WEATHER). The complete equipment comprises three items, which are interconnected by plug-ended cords: control unit, telephone and amplifier. The main features of this loudspeaking telephone are as follows:

- (a) Complete "hands-free" operation during a telephone call.
- (b) Transistor amplifier, drawing its power from the telephone line current.
- (c) Automatic control of the amplifier for both voltage regulation and line balance.
- (d) Attractively designed desk control-unit containing microphone, control keys, dial and indicator lamp. The volume-control key gives the choice of three levels of received volume.
- (e) The loudspeaker mounted in the telephone body.

(f) The telephone handset may be used at any time, with automatic change-over from loudspeaker on lifting the handset.

(g) "On" condition indicated by the lamp in the control unit.

Switchboards

There were two models in the new range of subscribers' cordless manual switchboards: they have capacities for (a) two exchange lines and six extensions¹¹ (2 + 6), and (b) three exchange lines and 12 extensions (3 + 12), and will supersede the existing 2 + 4 and 3 + 9 sizes, respectively. The increase in the number of extensions is the result of a study of statistical information which indicated that the ratio of extensions to exchange-lines should be made larger.

In spite of the increased capacity a considerable reduction in size has been made, as was seen from a comparison with the existing wooden-cased switchboards (underneath the stand in Fig. 4). The compact design and modern appearance has the approval of the Council of Industrial Design. The reduction in size has been achieved by the use of a new small key, which was separately displayed, the use of lamps instead of indicators, and the use of a new principle of operation which requires three wires and an earth to each internal extension.¹²

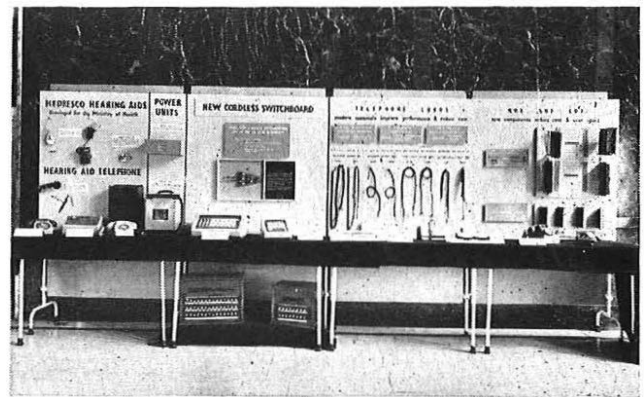

FIG. 4—CORDLESS SWITCHBOARDS, HEARING AIDS, M.D.F. COMPONENTS AND CORDS

Amplified Handsets and Hearing Aids

The new amplified handset (Handset No. 4)¹³ was displayed alongside the large battery-powered valve-operated amplifier in a mahogany box which it supersedes. This handset replaces the normal telephone handset, and the transistor amplifier on the printed wiring panel within the handle draws its power from the telephone line current.

Three types of Medresco* Hearing Aid were displayed:

- (i) OL.35A—a valve model having external l.t. and h.t. batteries; total weight, 1½ lb.
- (ii) OL.56—a transistor hearing aid¹⁴ with self-contained 1.5-volt battery; weight less than 3 oz. This aid supersedes the valve model.
- (iii) OL.57—similar to OL.56 but fitted with a pick-up coil for use with the inductive-loop systems installed in some schools.

* Medical Research Council.

Other Apparatus and Testing Equipment

An exhibit which aroused considerable interest was the new automatic answering set for telephone subscribers (Answering Set No. 1)¹⁵. Two telephones were connected to direct exchange lines, an answering set being associated with one of them. From the other telephone it was possible to call and listen to the recorded announcement of the answering set.

A prototype transistor "privacy-set," at present under consideration, was displayed with the existing valve-type Privacy Set No. 6A. The considerable reduction in size and the new set's independence from external power sources was a dramatic demonstration of the advantages to be gained from transistors.

There being insufficient space available to exhibit all the items of test equipment, the exhibits were changed from day to day to show a cross-section of the latest developments in this field. Such items as rheostats, oscilloscopes, a precision potentiometric voltmeter, a sensitive recording voltmeter using a novel d.c. amplifier, and an announcer with out-of-contact record and playback heads were shown. The use of transistors in portable testing equipment was illustrated by a comparison between an existing motor-driven Ohmmeter No. 9 and the Ohmmeter No. 13 which replaces it. The latter derives a 500-volt d.c. testing potential from a 9-volt dry battery. The technique of resin encapsulating transistor amplifiers and oscillators was demonstrated in the equipment developed for cable-pair identification. Measuring instruments displayed included the new small Meter, Multirange, No. 12, which has a sensitivity of 20,000 ohms/volt, and the Mark 3 version of Meter, Multirange, No. 3, which has printed wiring and overload protection.

Components and Telephone Cords

The components displayed included the latest fuses, fuse mountings and connexion strips, demonstrating how improvements in component design are helping to reduce costs and save space by increasing the capacity of the main distribution frame (M.D.F.) in telephone exchanges. In particular, the change in design of M.D.F. units has doubled the capacity of the existing frame and reduced the capital cost of the equipment provided.

The reliability of transistors was emphasized in many ways and, in particular, the function of CV specifications in ensuring this was demonstrated. "Rugged" and "non-rugged" valves were shown for an appreciation of the difference in their construction and the longer life expectancy of the "CV 4000" type valve. The way in which heat-dissipating shields reduce the temperature of valve bulbs, and hence extend valve life, was clearly

illustrated. The importance of good gold-plating and low contact-pressure for valveholders having gold-plated sockets was emphasized by examples of good and bad plating, and means of detecting these were shown.

The new range of telephone cords¹⁶ showed how, by using new materials such as p.v.c. in their construction, an improvement in performance is achieved, together with an estimated annual saving to the Post Office of over £200,000. The method of making the new extensible handset cord (a process considered impossible a few years ago) was shown, with examples of the successive stages.

Two panels demonstrated the great economies that can be achieved by modern production methods. One exhibit was the transmitter-inset case, which was originally formed from a brass disk in 15 operations and is now manufactured as a zinc die-casting in six stages; the other was the subscriber's meter cover, previously formed in 12 operations from a brass disk and now impact extruded from an aluminium pellet in one operation and trimmed and finished in a second operation.

References

- ¹ SPENCER, H. J. C., and WILSON, F. A. The New 700-Type Table Telephone—Telephone No. 706. *P.O.E.E.J.*, Vol. 52, p. 1, Apr. 1959.
- ² AKESTER, K. M. A Switching Unit for Use with 700-Type Telephones—Plan Set N625. (In this issue of the *P.O.E.E.J.*)
- ³ PEARCE, C. A. R. The New Combined Hand Microtelephone and Bell Set. *P.O.E.E.J.*, Vol. 31, p. 1, Apr. 1938.
- ⁴ SPENCER, H. J. C. A Table Telephone with Four Push-Button Keys—Telephone No. 710. *P.O.E.E.J.*, Vol. 53, p. 190, Oct. 1960.
- ⁵ SPENCER, H. J. C. The New Wall Telephone. *Post Office Telecommunications Journal*, Vol. 8, p. 6, Autumn 1955.
- ⁶ Trial of a New Type of Wall Telephone. *P.O.E.E.J.*, Vol. 53, p. 55, Apr. 1960.
- ⁷ BASTOW, F. J., COLLINGWOOD, J. D., NEWELL, E., and PRICE, C. K. The Pay-on-Answer Coin-Box System. *P.O.E.E.J.*, Vol. 51, p. 343, Jan. 1959.
- ⁸ BELK, J. L. An Improved Trigger-Type Dial—the Dial, Automatic, No. 21. *P.O.E.E.J.*, Vol. 53, p. 40, Apr. 1960.
- ⁹ ROBERTSON, J. S. P. The Rocking-Armature Receiver. *P.O.E.E.J.*, Vol. 49, p. 40, Apr. 1956.
- ¹⁰ SPENCER, H. J. C. A Light-weight Headset for Telephone Operators. *P.O.E.E.J.*, Vol. 53, p. 177, Oct. 1960.
- ¹¹ HALLIDAY, C. M., and LIDBETTER, E. J. Private Manual Branch Exchange Switchboard No. 2/2A. (To be published in the April 1961 issue of the *P.O.E.E.J.*)
- ¹² LIDBETTER, E. J. The 4-Wire Extension Principle for Small Cordless P.M.B.X. Switchboards. *P.O.E.E.J.*, Vol. 53, p. 167, Oct. 1960.
- ¹³ LOWE, W. T. A New Telephone for Deaf Subscribers—Handset No. 4. *P.O.E.E.J.*, Vol. 53, p. 24, Apr. 1960.
- ¹⁴ THWAITE, H., and ASPINALL, E. A Transistor Hearing Aid. *P.O.E.E.J.*, Vol. 52, p. 163, Oct. 1959.
- ¹⁵ RANDALL, F. L. An Answering Set for Telephone Subscribers. *P.O.E.E.J.*, Vol. 53, p. 45, Apr. 1960.
- ¹⁶ The Use of Modern Materials for Telephone Cords. *P.O.E.E.J.*, Vol. 53, p. 175, Oct. 1960.

Book Review

"A Course in Mathematical Analysis"—continued from p. 264

Goursat's masterpiece has been divided into two parts. The first part is confined to a treatment of the functions of a complex variable. It deals with the theory associated with contour integration in the complex plane and the calculus of residues. A better discussion of the fundamental theorems of complex integration would be hard to find. The second part is devoted to Prof. Goursat's theory of differen-

tial equations. Methods of solving both linear and non-linear differential equations are described and applied to practical problems. The treatment of partial differential equations is particularly attractive.

All these three volumes can be warmly recommended to students and engineers. They are all good examples of the new paper-back reproductions of classic mathematical texts now being published and sold at less than half the price of the same books in hard-covers.

H. J. J.

Emergency Mobile Teleprinter Automatic Switching Units

A. H. COULMAN and C. E. G. GOSS †

U.D.C. 621.394.72:629.114.3

Mobile switching units have been constructed to provide a rapid means of replacing a teleprinter automatic switching centre should one of these centres be seriously damaged or destroyed. The main features of these units and the facilities that they provide are described.

THE teleprinter automatic switching system* has a relatively small number of switching centres and, if one of these centres were put out of action for any reason, it would be difficult to restore service by diverting traffic to other centres. Mobile automatic switching units have therefore been provided so that, in such circumstances, the switching centre affected could be quickly replaced.

Each of the emergency switching units comprises two trailer vehicles, which together accommodate the necessary switching apparatus, common equipment and power plant. The units are self contained and require connexion only to the local cable network and to a single-phase 50 c/s power supply.

FACILITIES PROVIDED

Automatic equipment to serve a maximum of 120 station lines and 50 bothway trunk circuits is contained in the first of the two vehicles forming the mobile switching unit. Ancillary and common-services equipment is contained in the second vehicle.

A single mobile switching unit would be sufficient to restore service completely at one of the smaller area centres, but restoration of service at a larger centre would be restricted to the more essential station lines and trunk circuits.

To minimize the number of connexions to be made when the unit is brought into use the trunking scheme shown in Fig. 1 is used. This arrangement is the most suitable for meeting the different requirements at the centres which the mobile unit might have to replace.

Circuits are provided from level 0 of the 1st selectors to serve the local telegraph instrument room. One of the functions of the final selectors is to route to overflow

positions in the instrument room associated with the centre any calls to station lines which are out of order or engaged on long-duration calls. Level 1 of the final-selector multiple is teed to level 0 of the 1st-selector multiple for this purpose. Station lines may be connected to the final-selector multiple singly or in groups as necessary to meet the requirements of the offices served by the switching centre to be replaced. The waiting facility under busy conditions is provided for the larger groups of lines only. This facility enables a call to wait 30-60 sec for a line to become free if all the circuits in the group required are engaged. If a line does not become free during this period the call is switched to an overflow position. Overflow without the waiting facility is provided on the remaining station lines. Trunk relay-sets are connected to each of the remaining 1st-selector levels.

To conserve shelf space on the 1st-selector rack, special-services and ordinary final selectors share a common multiple. The special-service final selectors are connected from level 1, and the ordinary final selectors from level 2, of the 1st selectors. The special-service final-selector circuit permits manual holding of the calling station from the test position, but omits the waiting and overflow facilities of the ordinary final selector. Levels 9 and 0 of the final-selector multiple provide access to the test and miscellaneous engineering circuits. These circuits provide test messages at various degrees of distortion, a teleprinter-speed-test signal, and a clearing-test signal for the automatic check of station-line position equipment, when the appropriate test number is dialled.

TRAILER VEHICLES

A photograph of one of the vehicles is shown in Fig. 2. To obtain adequate headroom within the vehicles and at the same time keep the overall height to a minimum, low-loading-type chassis having a capacity of 8 tons are used. The interior of the bodywork is heat insulated by means of a layer of fibre-glass inserted between the outer aluminium skin of the body and the internal Masonite surface.

Since two vehicles are necessary to accommodate a complete switching unit, the bodies of the trailers are designed to facilitate their use in pairs. The entry door of one vehicle of a pair is on the off-side while the entry door of the other is on the near side so that, where site conditions permit, the trailers can be so placed that the doors face each other. Movement of staff between the vehicles is thus made easier.

The apparatus forming the switching unit is divided between the two vehicles so that the common equipment, i.e. power plant, signal-generation and distribution, testing and miscellaneous equipment, is contained in one trailer, while the automatic switching equipment is contained in the other.

Because of the need to ensure that the overall height of the vehicles does not exceed 13 ft, the apparatus racks are 8 ft 6 in. high and are of the standard type used

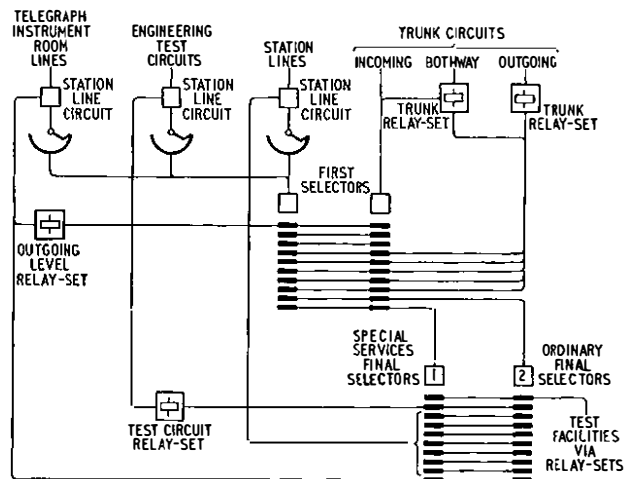

FIG. 1—TRUNKING DIAGRAM OF MOBILE SWITCHING UNIT

† Telegraph Branch, E.-in-C.'s Office.

* WILCOCKSON, H. E., and MITCHELL, C. W. A. The Introduction of Automatic Switching to the Inland Teleprinter Network. *I.P.O.E.E. Printed Paper No. 195, 1949.*



FIG. 2—MOBILE SWITCHING UNIT VEHICLE

in the teleprinter automatic switching system. Most of the jack-in equipment was obtained from stocks of surplus equipment.

Common-Equipment Vehicle

The interior layout of the common-equipment vehicle is shown in Fig. 3(a). The power rectifiers and batteries provide the 80 + 80-volt and 50-volt supplies required for the signalling and switching equipment. All standard telegraph service signals are supplied from the signal-generation and distribution racks.

The test-position has facilities for testing any circuit connected to the centre. All circuits are routed through an engineering control board (which is similar to a test-jack frame) and may be connected to the test-position circuit by means of cords. In addition to a

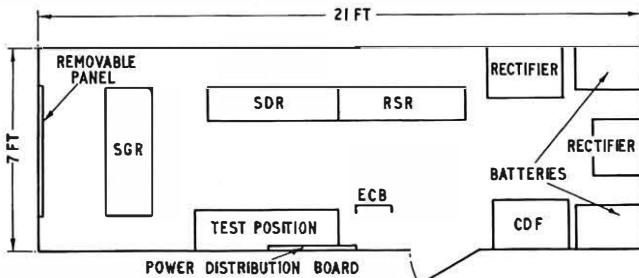

(a) Common-Equipment Vehicle

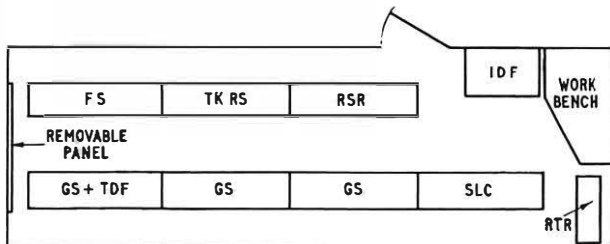

(b) Switching-Equipment Vehicle

SGR—Signal-Generation Rack. SDR—Signal Distribution Rack. RSR—Relay-Set Rack. ECB—Engineering Control Board. CDF—Cable Distribution Frame. FS—Final Selectors. TK RS—Trunk Relay-Sets. IDF—Intermediate Distribution Frame. GS—Group Selectors. TDF—Trunk Distribution Frame. SLC—Station Line Circuits. RTR—Routine Test Rack.

FIG. 3—LAYOUT OF EQUIPMENT IN VEHICLES

conventional d.c. voltmeter test circuit and dial-speed tester, the test position is equipped with an electronic telegraph-distortion-measuring set and a unit by means of which all common signal supplies may be monitored.

Polythene-sheathed cable tails for connecting the mobile unit to the main cable network and tie cables for interconnecting the two trailers are terminated on the small single-sided distribution frame at the front end of the vehicle. The cables pass through the floor into a storage locker beneath the vehicle. The main cable tails are sealed into a special watertight joint-box by means of expanding plugs. Entry tubes on the joint-box provide access for cables of various sizes for connexion to the main network. The inter-vehicle tie cables are terminated on 100-way sockets for connexion to plugs in the storage locker of the second vehicle. When the mobile unit is not in use the 100-way sockets and the joint-box are sealed and the cables stowed in the locker beneath the vehicle.

Switching-Equipment Vehicle

The layout of the equipment in the second vehicle is shown in Fig. 3(b).

The intermediate distribution frame is of the single-sided type and is cabled to 100-way plugs which are connected to the sockets of the inter-vehicle tie cables when the vehicle is brought into use, the 100-way plugs being accommodated in a locker beneath the vehicle, as previously mentioned.

The trunk distribution frame is arranged so that it forms part of one of the group-selector racks.

Routine testers for relay-sets, group selectors and final selectors are fitted on a common rack situated at one end of the trailer; access to these routine testers is provided by cabled connexions which are extended by cords on the appropriate racks.

A combined work bench and storage cupboard is fitted between the distribution frame and the routine-tester rack, and a comprehensive tool kit and an adequate stock of spare parts are provided.

POWER SUPPLIES, EARTHING, LIGHTING AND HEATING

The 50 c/s single-phase mains supply is connected to the common-equipment vehicle via an earth-leakage trip-circuit and an auto-transformer. An a.c. voltmeter and frequency meter are provided to monitor the mains supply, which is extended to the switching-equipment vehicle via v.i.r. cable and weatherproof 3-pin plugs and sockets. Connexions via a change-over switch are provided for a standby mains supply.

The 50-volt and 80 + 80-volt power supplies are derived from the mains via Westat-type rectifiers, and the equipment busbars of the two vehicles are interconnected via heavy-duty cables and 4-pin plugs and sockets.

Terminals are provided beneath the vehicles for connexion to a suitable earth system. Earth spikes are carried and are used to provide the earth connexion for the earth-leakage trip-circuit. They can also be used for the main earth should a suitable alternative source not be available.

The vehicles are fitted with fluorescent lighting and are ventilated by means of two-way fan units. Tubular heaters, which may be either controlled manually or by humidistats, as required, are fitted to the bases of the apparatus racks, and 1-kilowatt heaters are incorporated in the fan units in both vehicles to provide additional heating when necessary.

Signal Transmission Across the Atlantic via a Passive Earth Satellite

U.D.C. 621.396.946

ON 12 August 1960 the first earth satellite specifically intended as a passive reflector for experimental long-distance radio communication was launched into orbit from the U.S.A. Most readers of the Journal will doubtless have seen ECHO 1 as it travels across the night sky, looking like a prominent star and unusual only in so far as it is in very apparent motion relative to the true stars. They will have read that it is a spherical balloon 100 ft in diameter and coated with a highly-reflecting metallic skin. Its altitude above the earth is just over 1,000 miles and it travels around the earth at some 16,000 miles/hour, its orbital plane being inclined at about 47° to the equatorial plane.

Bell Telephone Laboratories (B.T.L.) participated in a very extensive series of tests of transmission between the east and west sides of the U.S.A. via the satellite. In the east-to-west direction the carrier frequency used was 960.05 Mc/s.

Once it was learned that it was likely that the B.T.L. (Holmdel Laboratory, New Jersey, U.S.A.) would continue to transmit the signals as the satellite travelled eastwards over the Atlantic, arrangements were made for the Post Office Research Branch to build a suitable receiver. Although the 10 kW transmitter feeds a very-high-gain horn aerial directed towards the satellite, the level of reflected signal received in the United Kingdom during periods when the satellite is visible from both transmitter and receiver is extremely low. It was necessary, therefore, for the receiver to be exceptionally sensitive, and to arrange for the demodulation of speech signals transmitted using a frequency-modulation system with very wide deviation.

A critical item of the receiver was a parametric amplifier* which, even without a circulator, achieved a noise factor as low as 4 db.

It will be appreciated that communication by reflection from the satellite is possible only when it is simultaneously visible from the sending and receiving stations. For transmission between New Jersey and southern England, the period of simultaneous visibility may be up to about 12 minutes per "pass" depending upon the time and the characteristic of the orbit. Further, as high-gain aerials have narrow beams, it is necessary for both transmitting and receiving units to be directed accurately towards the moving satellite.

Once it had been decided to receive the signals in the

* The Principles and Possible Application of some Amplifiers of Low Intrinsic Noise. *P.O.E.E.J.*, Vol. 52, p. 212, Oct. 1959.

United Kingdom, a major problem was that of obtaining a suitable aerial. Throughout the world, the number of large microwave aerials fully steerable in both azimuth and elevation is very small, and those available in the United Kingdom were already committed to other tasks. However, the Royal Radar Establishment at Malvern was able to produce a 20 ft diameter parabolic reflector complete with a mounting which enabled the reflector to be steered manually, and it was decided to carry out the experiment with this aerial. The Post Office receiver and associated equipment were installed at Malvern, the parametric amplifier being mounted immediately adjacent to the receiving horn fitted at the focus of the reflector.

The first few nights (and days) after the satellite was launched were occupied in optical tracking, aligning the aerial and practising the complex co-ordination involved in aerial steering and receiver adjustment (in connexion with the last of these it may be mentioned that the Doppler shift alone amounts, in any one pass, to several kilocycles/second).

It soon became apparent that orbit prediction data were extremely reliable and made it possible to steer the aerial without reference to optical sighting. Throughout the series of tests details of time, azimuth and elevation of satellite visibility at Malvern were provided, over a telex circuit, by the National Aeronautics and Space Administration in Washington; similar data were also obtained from the Radio Research Station of the Department of Scientific and Industrial Research.

By the night of 29 August all was in order for a communications test, and B.T.L. agreed a schedule of transmissions involving, in each of three consecutive passes, C.W. followed by modulation. To all those who took part in the experiment it was an inspiring moment when, exactly on time, the first signal was received; it was also most encouraging to find that signal levels were as predicted from theoretical considerations and that all the complex equipment worked most satisfactorily. Signals were observed on all the agreed passes.

The experiment is another example of what can be achieved by international and national co-operation. It is desired to record the first-class co-operation afforded by the Bell Telephone Laboratories, the National Aeronautics and Space Administration in the U.S.A. and by the Royal Radar Establishment and the Department of Scientific and Industrial Research in this country.

F. J. D. T.

Book Received

"Wireless World Diary, 1961." T. J. & J. Smith, Ltd., in conjunction with *Wireless World*. Eighty pages of reference material plus diary pages of one week to an opening. Size 4½ in. × 3¼ in. Leather, 6s. 9d.; Rexine, 4s. 9d.; postage, 4d.

The reference section of this diary contains the addresses of

over 150 radio and allied organizations in this country and abroad, tabulated details of the world's television standards, dimensions of the elements of aerials for television and v.h.f. sound broadcasting, tabulated base connexions for over 700 current receiving valves, channels and frequencies of U.K. television and v.h.f. sound broadcasting stations, graphical and letter symbols used in radio, and a variety of other information.

A 150-Foot Mast for Radio Stations

S. G. YOUNG, B.Sc., A.M.I.E.E.†

U.D.C. 621.315.668.2:621.396.67:621.396.7

To meet the need for a robust, economical, aerial-supporting structure for use at modern high-frequency radio transmitting and receiving stations, a light lattice-type steel mast has been designed. The mast was designed to carry two rhombic aerials, at heights of 75 ft and 150 ft, operating in the frequency range 4–28 Mc/s. A prototype mast was tested to destruction, and the results of this test and the subsequent provision of some 400 masts have proved their reliability, their cheapness, the ease with which they can be erected, and their adaptability for a variety of uses.

INTRODUCTION

SOME time ago the Post Office designed a light lattice-type steel mast to meet the need for a robust, economical, aerial-supporting structure which could be produced in large numbers for use at modern high-frequency radio transmitting and receiving stations. The mast has proved very suitable for a wide variety of radio structures.

The height above ground at which an aerial is erected is an important factor in its design, and the choice of height for a mast which will have to meet varying aerial requirements over a frequency band of 4–28 Mc/s needs to be made with some care. Since the costs increase at a rather greater rate than the square of the height it is necessary to justify, at least in some degree, any increase in aerial height by a worthwhile improvement in circuit reliability.

ELECTRICAL REQUIREMENTS

The electrical requirements for the supporting structure of an aerial are twofold. Firstly, the presence of the structure must not appreciably degrade the performance of the aerial. Inevitably the front support of a rhombic aerial is in the direct line of radiation, and if constructed of metal it could be expected to have some effect on aerial performance. However, extensive tests with models have shown that a slender, vertical, metal mast has negligible effect compared with, say, a self-supporting tower, and that continuous metallic stays cause little interference with aerial performance.

Secondly, the height of the mast fixes the maximum height to which the aerial can be hoisted, which in turn

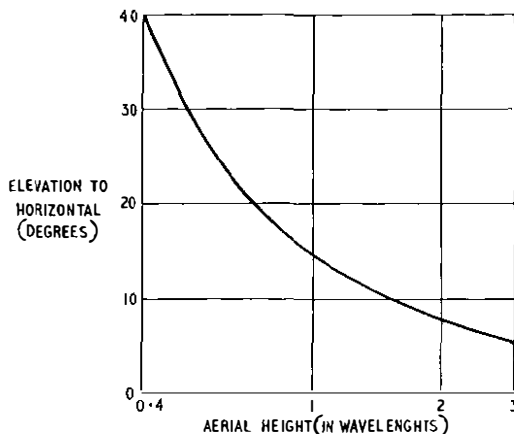

FIG. 1—RELATION OF AERIAL ELEVATION AND AERIAL HEIGHT FOR DIRECT AND REFLECTED RAYS TO REINFORCE EACH OTHER

determines the lowest angle to the horizontal at which the maximum radiation can be directed at any particular frequency. At the frequencies being considered here the earth acts as a good reflector of radio waves, and the angle of inclination to the horizontal at which direct and reflected rays reinforce each other decreases with increasing aerial height, as shown in Fig. 1. The aerial is designed so that the maximum intensity of radiation occurs at this elevation, thereby securing the maximum advantage from the earth's reflection. The choice of height for the mast is largely controlled by performance requirements at the lower frequencies and is clearly of major importance.

Experience shows that, except on radio circuits which extend nearly to the antipodes, the best bearing along which to radiate or receive radio signals is generally close to the great-circle bearing. In the vertical plane, however, the optimum angle of elevation depends upon a number of factors, including the operating frequency, and it is usually predicted for the circuit in question by radio-propagation specialists.

Predictions of the range of optimum angles of elevation at the highest and lowest frequencies used throughout the 11-year sunspot cycle are shown in Fig. 2, which also

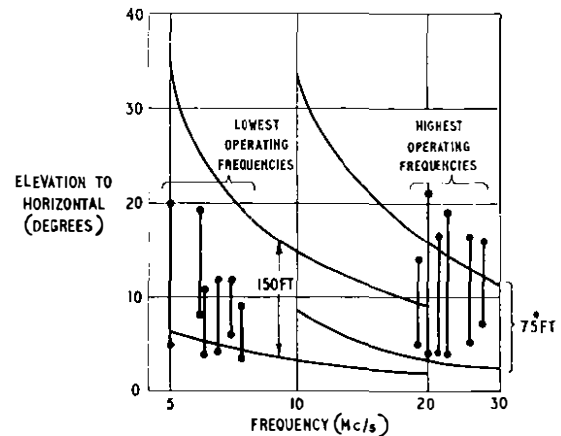

FIG. 2—RANGE OF OPTIMUM ANGLES OF ELEVATION FOR 11-YEAR SUNSPOT CYCLE AND EFFECTIVE BEAM WIDTHS IN THE VERTICAL PLANE

shows the effective beam widths in the vertical plane of two typical rhombic aerials erected at 150 ft and 75 ft above ground. It will be observed that a height of 150 ft gives a reasonable performance at the lower frequencies but it is too high for the higher frequencies, for which an aerial at a height of 75 ft is more appropriate. Thus, at least two aerials are required for each circuit.

MECHANICAL REQUIREMENTS

Since the mast was intended for use in a wide variety of situations, including coastal sites, it was decided to design it to withstand fairly severe climatic conditions

† Overseas Radio Planning and Provision Branch, E.-in-C.'s Office.

and a wind-loading equivalent to a steady wind speed of 100 miles/hour.

At low altitudes, ice is not normally accompanied by high winds. The densest and thickest coatings of ice are formed by freezing fog, or under temperature-inversion conditions when small droplets of water from a relatively warm atmospheric layer fall on to a structure in a lower-temperature region which is below freezing point; both these conditions require calm weather for their continued existence at low altitudes. Very little ice is formed on the relatively large members of a mast, or, for some not wholly understood reason, on the stays, and what small amounts of ice there may be add little to the static loads. On the other hand, thin horizontal aerial wires, being free to twist, rapidly take on a thick coating of ice under such conditions. This increases the effective weight of the wire several times, causing a considerable increase in tension.

The supporting masts are the most expensive part of an aerial system and are also the most difficult to replace. Hence, if excessive stresses are likely to arise it is desirable that the aerial should fail before the mast is in serious danger. Thus, in designing the mast, insulators and wires were chosen so that the ultimate aerial load would be about one ton at each point of attachment, in addition to the wind load applied over the length of the mast.

DESIGN

It was clearly advantageous for the mast to be composed of identical interchangeable sections, short enough to be carried in standard vehicles and easily handled. Stays in three directions, giving an included angle in plan of 120° between stays, interfere to the minimum extent with the rigging of a rhombic aerial. This favours a mast of triangular cross-section, which has the advantages over a square cross-section of being self-rigid, requiring no internal bracing, and reducing the number of joints to be made during fabrication and assembly.

The ratio of the effective-length to radius-of-gyration of the cross-section, l/k , mainly determines the strength of a strut in a given material. A value of 80 for this ratio was selected for the inter-stay sections of the mast and also for the legs of the sections between bracing points, in order that both should be equally strong in compression. Effective-length is the length of the

equivalent pin-ended strut, which for these sections is the full length between supports, as stays or bracings produce negligible torsional restraint. Deformation may take the form shown in Fig. 3.

Briefly, the design procedure was, firstly, to determine approximately the cross-sectional dimensions on the assumption that the stays would act as rigid supports of a mast composed of four sections where each section was 37 ft 6 in. long. These calculations were made for masts with sections constructed in various ways. A design employing legs of $1\frac{3}{4}$ in. mild-steel angle braced by round rods was selected as the most promising. A more elegant design using tubes was found to be 30 per cent lighter in weight, but would probably have been more expensive due to the higher cost of materials and more complicated jointing between the sections.

The accurate design of a stayed mast is relatively complicated, for the mast is supported by elastic stays, each of which hangs in a shallow catenary, and the effective stay tensions are affected by the action of wind upon them. It is possible to select stay sizes and initial tensions so that under given loading conditions the mast will heel uniformly, remaining unbent. But the wind and aerial loads may combine in many ways causing the mast both to move from the perpendicular and to bend, sometimes in a highly complex manner. It is necessary to examine several of these combinations to ensure a satisfactory design and to check that the initial stay tensions are correctly chosen. High-tensile steel wire of 7/12 S.W.G.* was chosen for the stays at the aerial attachments, i.e. at 75 ft and 150 ft, and lighter wire of 7/14 S.W.G. was chosen for the unloaded stay points. To reduce work at the site all stays in the same vertical plane were considered as being brought to the same anchor, 105 ft from the mast. By specifying an initial tension of 4 cwt the dip could be made small enough for the stays to be relatively insensitive to incorrect adjustment, and the majority of the extension under load would be due to elastic stretch. The effect of a 100-miles/hour wind upon the stays was included in the calculation of the reaction of the sets of three stays against movement of the mast, by making an appropriate adjustment to their effective weights.

If for the time being the downward thrust due to weight and stay compression is neglected, the mast may be regarded as a continuous beam on knife-edge supports that sink under load (Fig. 4 (a)), for the stays offer no torsional restraint. The load-deflexion characteristics of the supports are those of the several sets of stays. The stiffness of the mast causes loads applied at any point to be shared over all the supports in a manner dependent upon the degree of stiffness and the rigidity of the supports. Fig. 4 (b) shows the typical effect of a load P applied at any point. The detailed calculation is beyond the scope of this article, but the steps are as follows. Firstly, the mast is treated as resting on infinitely-rigid knife-edge supports—a standard structural case. Then the effect upon the loads carried by all the supports is determined for the deflexion of each support in turn (Fig. 4 (c)). Finally, by a process of systematic trial and error,† each support is allowed to deflect in turn, throwing additional loads upon the other supports, until the loads carried by each are the loads that can be sustained by the appropriate set of stays under similar deflexions.

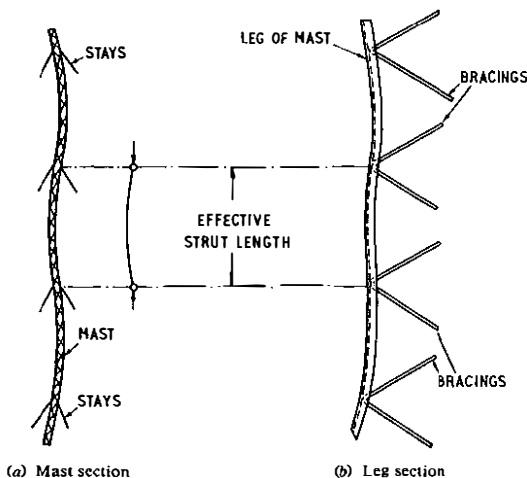

FIG. 3—DEFORMATION OF SECTIONS UNDER COMPRESSIVE LOAD

* Seven strands of No. 12 S.W.G. wire.

† SOUTHWELL, R. V. *Relaxation Methods in Engineering Science* (Oxford University Press).

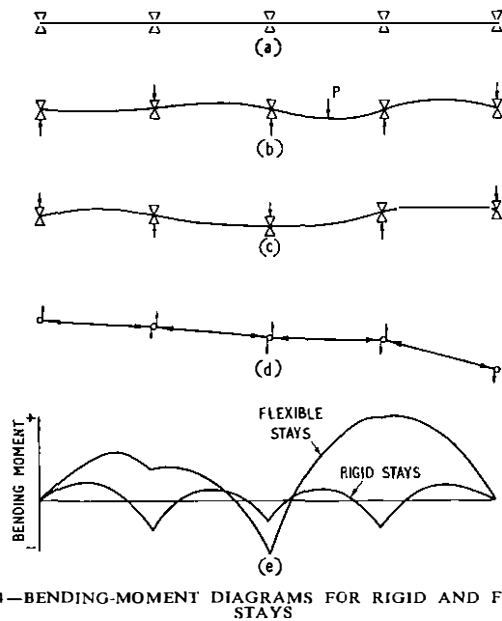

FIG. 4—BENDING-MOMENT DIAGRAMS FOR RIGID AND FLEXIBLE STAYS

This is a partial solution. The compression in the mast due to its own weight and to the downward thrust of the stays causes further lateral forces which have to be withstood by the stays (Fig. 4 (d)). These are added to the stay loads and the calculation, which rapidly resolves, is repeated. A comparison of the bending-moment diagrams of a mast of this design when overloaded is given by Fig. 4 (e), where fully-rigid supports and one possible set of actual conditions with flexible stays are assumed. The inaccuracy of the fully-rigid-supports approach is very evident.

The final design (Fig. 5 (a)) employs sections 12 ft 6 in. long. Each section is composed of three parallel legs of $1\frac{3}{4}$ in. \times $1\frac{3}{4}$ in. \times $\frac{3}{16}$ in. mild-steel angle, at the corners of an equilateral triangle of $14\frac{3}{8}$ in. side. The bracing is formed of solid $\frac{1}{2}$ in. diameter mild-steel rod, which is bent to fit snugly into the root of the angle (Fig. 3 (b)) and is welded in position. Thus, the joints are made substantially at the centroids of the leg sections, and

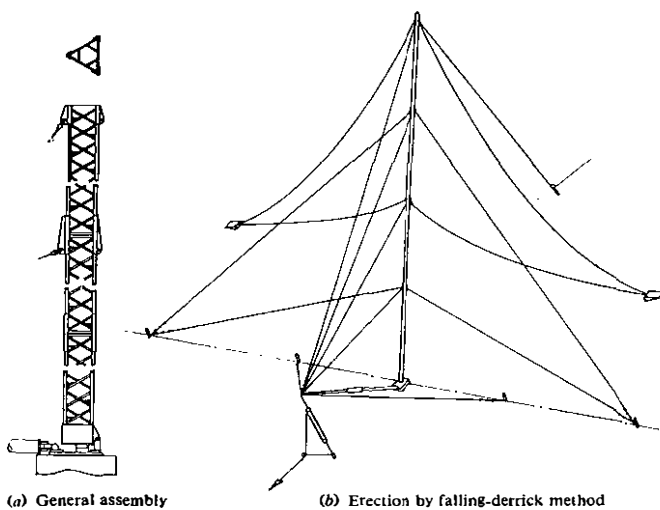

FIG. 5—CONSTRUCTION AND ERECTION OF MAST

should a weld fail under extreme stress, the bracing, being in effect a continuous zig-zag trapped within the angles, would maintain the stability of the section as a whole. Steps of round rod are welded to the bracing, on one side. All components are hot-dipped galvanized after manufacture, particular attention being paid to the cleaning and preparation of the welds between braces and legs.

One end of each stay is shackled to the mast at a stay-attachment plate and to a rigging screw at the lower end, the four stays in each of the three directions being fixed to the same concrete anchor block. The stay-attachment plates also serve to join the sections, but at other levels without stays angle plates are used.

A completed 150 ft length of mast weighs 1,500 lb and requires 432 identical $\frac{1}{2}$ in. diameter bolts. As shown in Fig. 5 (a), for erection purposes two lugs in the base fit into stirrups on the foundation plate, and the "falling derrick" (Fig. 5 (b)) used to raise the mast is similarly attached to the foundation. An initial pull of about 50 cwt is required on the falling derrick. When vertical the mast rests upon a 1 in. diameter steel ball.

MAST TESTED TO DESTRUCTION

In order to prove the design, a prototype mast was tested to destruction. A site was found at Rugby radio station where the mast could be erected near two existing 180 ft towers so that one tower could be used to apply two loads of 1 ton each, simulating aerial loads at 75 ft and 150 ft, and the other to apply 12 pulls, one at the centre of each 12 ft 6 in. section, to simulate a uniform 100-miles/hour wind load at 90° to the simulated aerial pulls. Mast deflexions agreed closely with the calculated values, and when the simulated aerial loads were doubled the mast showed no signs of distress although theoretically it was liable to failure. To allow the simulated aerial loads to be increased still further the back stays were reinforced, and then the loads were increased to 5.2 tons, at which point failure occurred.

This was reassuring, but it gave a somewhat false impression, for on reworking the calculations for the reinforced back stays it was found that the mast failed at a stress only slightly exceeding the theoretical value. The test, however, showed that the method of design was accurate, and that the mast was rather stronger than supposed. This was deemed to be due, at least in part, to the method of construction of the sections, in which the bracings are trapped within the leg angles.

CONCLUSIONS

Some 400 masts have been used to date, and they have proved to be cheap, easy to erect, and adaptable to a variety of uses. Some have been employed on v.h.f. and s.h.f. propagation testing, others at the fixed station of mobile services, and several mast radiators are in use on maritime m.f. services. Where a lighter head-load is permissible the height has been extended to 187 ft 6 in., employing 15 sections and five sets of stays.

Manufacturing jigs have been found to be simple, the work is within the capability of the majority of firms, and the materials have never been very difficult to obtain. However, it has been found necessary to devise a special test jig to check the straightness, freedom from twist, and end drillings of the sections, to ensure a straight mast and easy assembly.

Felling of Latticed Steel Masts at Somerton Radio Station

U.D.C. 624.059.6:621.315.668.2

A GENERAL reconstruction of the aerials and transmission lines at Somerton Radio Station, near Yeovil, has made a complete rearrangement of the aerial system necessary.

Opportunity is being taken to replace the old masts, which are up to 33 years old, by masts of modern design, and this should result in a considerable reduction in maintenance costs. The masts to be removed, 27 in number, are parallel-sided latticed-steel structures with a 12 ft square cross-section. Twenty-one are 289 ft high and weigh 33 tons each; the remainder are 262 ft high and of 30 tons weight. Each mast is bolted solidly to its concrete foundation and, in addition, is supported by four stays attached at about 200 ft from the ground. Each mast is surmounted by a cross-arm 90 ft in length. There are also a considerable number of smaller masts of the multi-stayed type up to 100 ft in height.

The removal of such a large quantity of plant is a major undertaking, particularly as the full operational efficiency of the station has to be maintained throughout. Siting and erection of new masts must proceed alongside the old structures and some restrictions in the methods of recovery are therefore unavoidable. Considerable saving in costs can, however, be effected if masts can be felled and dismantled on the ground, instead of being taken down by normal dismantling methods, and it should be possible to remove 18 of the large masts by felling, without danger to other installations on site.

The operation of felling is most spectacular, but without hazard if it is carefully carried out and spectators keep well clear. In calm weather and with the aerial system dismantled and the stays uncoupled from their ground anchorages, each mast is unbolted from the base fishplates. The structure is then free standing, but with a hawser attached to the top and to a tractor some 500 ft away in the direction of fall. It has been calculated that a mast of the type described, unshackled and free in this manner, is safe from overturning against a uniform wind normal to a face and not exceeding 25 miles/hour. To allow a reasonable safety factor felling operations are confined to periods of good weather with a measured wind speed on site of less than 10 miles/hour. A pull on the tractor hawser of about $\frac{3}{4}$ ton is sufficient to unbalance the mast, and the fall is completed in less than 8 seconds.

As expected, the mast falls square without distortion until it hits the ground, when considerable buckling of the structure occurs, particularly in the upper sections and cross-arm, where many bolts are broken in shear. At the end of the fall the structure moves forward bodily approximately 11 ft along the direction of fall. Fig. 1 shows a mast on its way down and Fig. 2 shows it on the ground after impact.

At the time of writing, four of the 289 ft masts have been felled and the recovery of the remainder is in

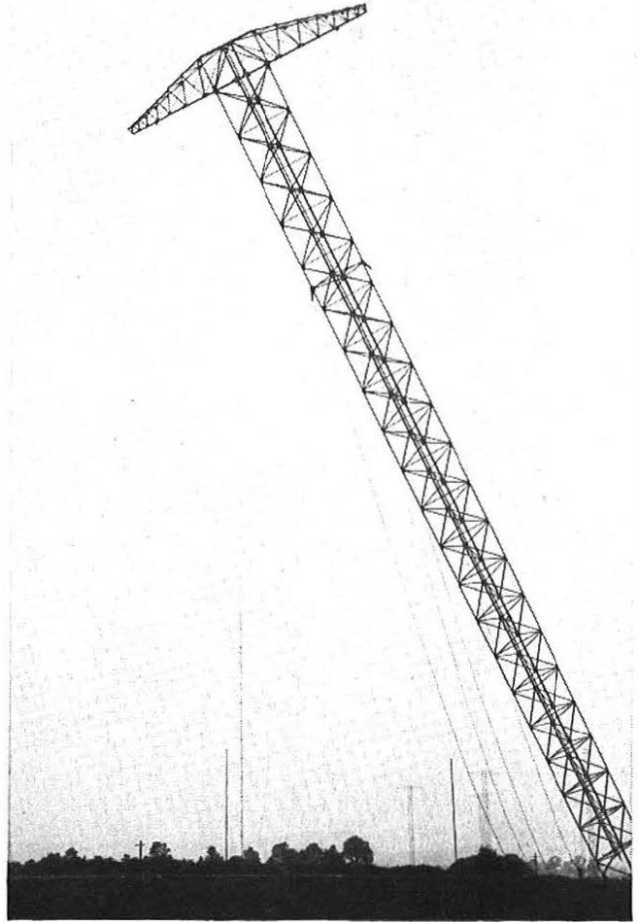

FIG. 1—MAST FALLING

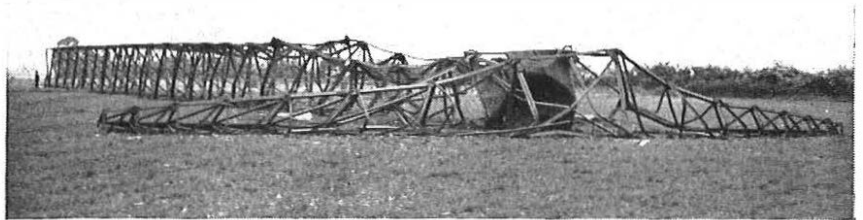

FIG. 2—MAST AFTER BEING FELLED

progress. It is expected that the reconstruction program will be complete by mid-1961. Steel structures weighing in all about 1,000 tons will then have been replaced by galvanized-steel masts 187 ft 6 in. in height with a total weight of no more than 75 tons.

F. A.

Testing Facilities on Test-Desks in Automatic Telephone Exchanges

H. C. ADAMS and L. W. PRATTEN, A.M.I.E.E.†

U.D.C. 621.317 : 621.395.72

Technical changes in the telephone system and the need for more-accurate measuring instruments have led to the redesign of the test-desk. The new test-desk, known as the 56-Type desk, is being provided at new telephone exchanges, and certain of the improvements will be incorporated in existing test-desks.

INTRODUCTION

FOR the maintenance of a good telephone service, it is essential that faults be located and cleared quickly and that the test-desk facilities should be adequate for this purpose. Although largely the result of technical changes in the telephone system, improvements which are at present being made in test-desk facilities arise also from the need to provide adequate means for the clearance of faults on subscribers' apparatus and lines.

In spite of a continuous reduction in the fault complaint rate since the war, radical improvement cannot be effected without a persistent attack on the cause of recurrent and incipient faults. Indeterminate "clears" and "right when tested" often arise from complaints such as "cannot get exchange"; increased accuracy of the test-desk testing equipment should help to effect an improvement in dealing with such faults.

The shortcomings of the existing testing circuits are discussed in this article and a description is given of new testing circuits which are being embodied in a redesigned test-desk, to be known as the "56-Type" desk.

EXISTING TEST-DESK FACILITIES

A review of existing test-desk facilities showed that:

(a) A number of telephone dials were being changed needlessly, whilst many faulty dials remained undetected.

(b) Introduction of the 1,000-ohm limit for the resistance of subscribers' lines necessitated more accurate resistance measurements.

(c) Simulation of subscribers' calling signals under the worst conditions permissible for both direct and shared-service exchanges lines was desirable.

(d) Improvements in transmission testing facilities were needed at trunk group centres if reduction in "out-of-service" time, especially of the more-important trunk circuits, was to be realized.

With these main factors in mind, the testing facilities and circuits were redesigned and improved as described below.

PULSE SPEED AND RATIO TESTING OF DIALS

To test both the pulse speed and pulse ratio of a subscriber's dial via the line, a new circuit was developed. Laboratory tests have shown that it is very accurate.

The test circuit is expensive and only one will be provided for each suite of test-desks, with access from all positions except junction testing positions, which will have access to the instrument only if the frequency of making pulse-distortion measurements on trunk circuits with out-of-speech-band voice-frequency signalling makes it necessary.

A saving in equipment and space is made by sharing the microammeter used in this tester with the Wheatstone bridge circuit referred to later.

RESISTANCE MEASUREMENTS

Subscribers' Loop

With the extension of the subscribers' line resistance to the permissible maximum of 1,000 ohms, more accurate measurement of resistance is necessary. Earlier changes, such as the introduction of the 300-type telephone,¹ in which the transmitter is connected in the signalling path, shared service, and the extension of remote testing, i.e. testing over junctions to remotely controlled exchanges, also contributed to reducing the effectiveness of the former testing methods.

The anti-side-tone induction coil shunting the transmitter in the earlier telephones made it possible to measure the signalling-loop resistance, and a high-resistance fault was readily apparent by comparison with the expected resistance of the subscriber's loop. The present 300-type telephone circuit and the new 700-type telephone make this test ineffective because the small testing current (3-4 mA), compared with the normal working current, results in the transmitter exhibiting a relatively high resistance.

Experience of the 300-type telephone showed that it was desirable to measure the condition of the signalling loop because of the occurrence of many "cannot get exchange" faults caused by momentary high transmitter resistance. These difficulties are increased when the instruments are used with 1,000-ohm lines.

In the new test-cord circuit, the testing difficulty has been overcome by connecting the voltmeter as a milliammeter and measuring the signalling current flowing, thus determining whether the signalling resistance is low enough for the correct operation of the calling relay. It will be possible to make this test with the co-operation of the subscriber and the need for a visit by a faultsman can thus be determined.

Loop and Earth Resistance Measurements

With the existing arrangements, measuring the resistance of metallic pairs and shared-service-installation earth connexions has been neither easy nor precise. The present method, using a voltmeter circuit, with voltmeter constant and chart, is inherently inaccurate, and errors of up to 25 per cent are possible. Furthermore, the range of subscriber's loop resistance is such that the reading is restricted to a small portion of the voltmeter scale. Used in this way, therefore, the voltmeter method must be regarded as little more than a continuity tester and a means of detecting varying high-resistance connexions in a circuit. Earth-resistance measurements involve even larger errors and results of these tests are again of little value, often indicating faulty earth connexions to be satisfactory, with resulting complaints from shared-service subscribers. At other times, satisfactory earth connexions are shown as faulty.

Redesign of the test circuit for subscribers' loop and earth-resistance measurements, using a Wheatstone bridge,² has resulted in a great improvement in accuracy (better than 3 per cent error over most of the scale),

† Telephone Exchange Standards and Maintenance Branch, E.-in-C.'s Office.

particularly for remote testing and earth-resistance measurements where there is an earth potential difference. A counter-e.m.f. battery associated with a potentiometer is incorporated in one arm of the bridge to balance out these potential differences.

The microammeter associated with this circuit is the same instrument as that used in the dial tester.

Measurement of Insulation Resistance

The voltmeter used on existing test-desks for the measurement of insulation resistance is arranged so that most accurate results are obtained when measuring resistances of approximately 0.25 megohms, which corresponded to the minimum insulation resistance allowed on subscribers' lines at the time the test-desk was introduced.

Present-day requirements are for improved insulation resistance and a value between 1 and 2 megohms is envisaged for subscribers' lines. With the existing testing arrangements, which make use of a voltage-resistance conversion chart, 1 and 2 megohms correspond to points where the meter scale is cramped and of doubtful accuracy. The existing circuit has therefore been replaced by one incorporating a more-suitably-calibrated direct-reading resistance scale with a zero-setting adjustment. This has an accuracy of 3 per cent or better over most of the scale and operation should be simpler.

SIMULATION OF SUBSCRIBERS' CALLING CONDITIONS

A test which has been found effective in the past is the simulation of subscribers' calling conditions, using either loop or earth signalling. Before the war, the longest subscribers' line in the average exchange area had a loop resistance of approximately 450 ohms. As the resistance of the D and I relay loop in the test-cord circuit was then 800 ohms, it was possible to deal with a "no dial tone" fault from the test desk, proving the calling equipment in the exchange by a loop condition.

The introduction of shared service and the extension of the subscriber's loop resistance to 1,000 ohms, together with a reduction in the resistance of the test cord D and I relay loop to 500 ohms, made this method of simulation no longer reliable. To restore this facility, there are four "worst" conditions to simulate, namely: maximum resistance of shared-service and exclusive lines in both 650-ohm and 1,000-ohm limit exchange areas. These conditions are chosen by four different positions of two keys.

An extension of this facility has also been given by the insertion, under key control, of a potentiometer to simulate the required conditions over test junctions of different resistances to remotely tested exchanges.

TRANSMISSION TESTING

Under the present transmission control procedure, more transmission testing than formerly is done at trunk group centres. A special automatic-answering transmission-test relay-set is installed at zone centres for automatic transmission testing by other zone and group centres. To use this facility and to speed up normal transmission testing, several changes have been made, as follows:

(a) Two oscillator outputs may be switched into the test-cord circuit, under key control. The frequencies are

* dbm—decibels relative to 1 mW.

1,600 c/s for end-to-end tests via the relay-sets, and 800 c/s when testing with repeater stations.

(b) A variable attenuator has been incorporated in the test-cord circuit.

(c) A high-gain amplifier allows measurements of received signals down to -50 dbm.*

(d) The test-cord circuit has been split into "line" and "exchange" portions, providing the fullest flexibility of the available facilities.

As a result, terminated-level and through-level transmission measurements at a 600-ohm impedance point can now be made, and arrangements for sending and receiving of test tones, together with signalling and speech facilities, are available from either portion of the test-cord by operating the appropriate keys.

The cumbersome arrangement whereby test signals were transmitted to line via a separate cord often resulted in connexions being released when cords were changed, and this arrangement has been superseded.

MISCELLANEOUS FACILITIES

Whilst retaining the desirable features of the existing testing facilities, other minor facilities which could be given at little extra cost have been incorporated in the new test-desk. One of these is the use of an interrupted number-unobtainable tone which can be transmitted via the "speak" cord for the purpose of circuit identification. Having located the required circuit, a "loop" will disconnect the tone and call the test-desk. Subsequent communication between test clerk and faultsman over the circuit is established by changing the key on the test-desk from the IDENTIFY to the SPEAK position.

The "howler" circuit has been connected via a locking key, the subscriber's loop controlling the start condition to avoid the risk of acoustic shock. A supervisory signal is given.

Changes to the face-equipment layout of the test-desk have naturally followed the changes in facilities, the most significant being the occupation by two meters of the space previously taken by the single voltmeter (Voltmeter No. 36). One is a multi-range meter used for voltage, current and insulation-resistance tests; the other is the centre-zero microammeter used for pulse speed and ratio testing and loop and earth resistance measurements. Variable potentiometers also form part of the face equipment. They are used in the pulse testing and Wheatstone bridge circuits.

CONCLUSION

The facilities briefly outlined in this article will be incorporated in new exchanges in the future. Some of the more important features will be applied retrospectively at maintenance controls and be built into the existing single test-cord circuit; these are: pulse speed and ratio testing, the Wheatstone Bridge, loop simulation testing and the direct-reading ohmmeter.

With the implementation of the improvements to testing circuits described in this article, further attention will be given to the physical design of the test-desk, particularly in regard to integrated card filing, cordless design and a more modern and pleasing appearance.

References

¹ PEARCE, C. A. R. The New Combined Hand Microtelephone and Bell Set. *P.O.E.E.J.*, Vol. 31, p. 1, Apr. 1938.

² Wheatstone Bridge Circuit for Test-Desks. *P.O.E.E.J.*, Vol. 53, p. 205, Oct. 1960.

Closed-Circuit Colour Television

J. B. HOLT, A.M.I.E.E., and R. GARDINER†

U.D.C. 621.397.132

The Post Office has for many years provided vision circuits for television outside broadcasts for the broadcasting authorities on telephone cable pairs equipped with portable video amplifiers. Since 1956 a number of similar circuits have been provided by normal outside-broadcast methods for the transmission on closed circuits of colour television signals to the modified American National Television System Committee standards.

INTRODUCTION

IN recent years many commercial undertakings and government departments have shown an increasing awareness of the possibilities of television for showing audiences, assembled at convenient centres, scenes of interest as they occur in other parts of the country or in locations where, for one reason or another, access by large numbers of persons is either inconvenient or dangerous. To overcome these difficulties, the pictures are televised on a closed-circuit basis, i.e. the signals from the television camera unit are carried by a suitable vision circuit direct to the picture receivers.

Particularly interesting examples of this type of transmission are the demonstrations in London of colour television, given to the C.C.I.R.* Study Group XI in 1956 and to the Post Office Telephone and Telegraph Society in 1957, and the current series of demonstrations in colour of surgical techniques. In the latter demonstrations, scenes with commentary have been relayed from the operating theatres of a number of hospitals to audiences of medical practitioners and students, and it will be readily appreciated that the use of colour instead of monochrome for such transmissions gives vital significance to the pictures.

The colour system employed on all these occasions was that developed for the American National Television System Committee (N.T.S.C.), modified for 405-line working and transmission over vision circuits having a nominal band-width of 3 Mc/s. The connecting circuits, provided by the Post Office on telephone and/or coaxial cable pairs, were all operated at video frequencies, using normal television outside-broadcast (O.B.) methods.

THE MODIFIED N.T.S.C. COLOUR SYSTEM

Colorimetry, and the Acuity of the Human Eye

The reproduction of colour can be achieved by a suitable mixing of the three primary colours, i.e. red, green and blue. A colour television system could be designed in which the televised scene would be scanned by three camera tubes, each sensitive to one of the primary colours. The signals from these tubes (or channels) could then be transmitted to a reproducing device which would separately reproduce the primary colours of the original scene. Full reproduction would then be accomplished by optical superposition of the three primarily-coloured pictures. There are three main objections to this system.

(a) Each of the three channels would require the same band-width for a given definition (by monochrome standards) and would require to be electrically identical. Thus, a colour system based upon this design would

require three times the band-width of a monochrome transmission of equivalent definition. Since the monochrome systems in use throughout the world include considerable band-width redundancy, three separate channels would be wasteful, and country-wide circuits impracticable.

(b) The system is "incompatible" in that, used for normal public service, a satisfactory picture could not be obtained from a normal monochrome television receiver.

(c) It has been established experimentally¹ that the perception of colour by the human eye varies according to the angle subtended at the eye by the coloured object or patch of colour. As the size of the coloured area decreases, colours at the red end of the spectrum tend to be confused with and perceived as shades of orange (for equal brightness), whilst colours at the blue end of the spectrum tend to be similarly confused and perceived as blue-greens (cyan). Further reduction in size of the coloured area results in the absence of all sense of colour, fine detail being perceived only as shades of grey. Comparatively narrow-band transmission of full-colour, i.e. representing all three primary colours, would meet the capabilities of the human eye, whilst slightly wider-band transmission would be satisfactory along the orange-cyan axis of the colour triangle.² Full detail need only be transmitted in monochrome.

Consideration of points (a)–(c) resulted in the conception of the N.T.S.C. colour-television signal, which meets the requirements of band-width economy, compatibility, reverse compatibility, and adequate presentation of the colour information.

Characteristics of the Signal

If a televised scene is to be reproduced in full colour, three separate signals are required to define the colour of some parts of the scene, though these three signals need not necessarily represent the three primary colours. In the N.T.S.C. system³ the signals are as follows:

(i) *Luminance Signal.* By the addition of suitable proportions of the video-signal voltages generated by the red, green and blue sensitive camera tubes, a monochrome signal can be constructed which represents only changes in brightness within the televised scene. This "luminance" signal, when modulated on to a radio carrier for broadcasting purposes, may be received by monochrome television receivers and reproduced as a monochrome picture of normal definition, thus meeting the condition of compatibility.

(ii) *Chrominance Signals.* Two further signals, known as the "chrominance" signals, are required to define the colour of the televised scene at any instant during the picture scanning. These two signals, designated "I" and "Q," respectively, are derived from two colour-difference signals, each taking the form of a video waveform representing the difference between the output of one of the three camera tubes (red and blue outputs are taken) and the luminance signal. The "I" signal is then limited in band-width to approximately 1.0 Mc/s, whilst the "Q" signal is limited to 350 kc/s.⁴ The two chrominance signals are then modulated in phase

† Main Lines Development and Maintenance Branch, E.-in-C.'s Office.

* C.C.I.R.—International Radio Consultative Committee.

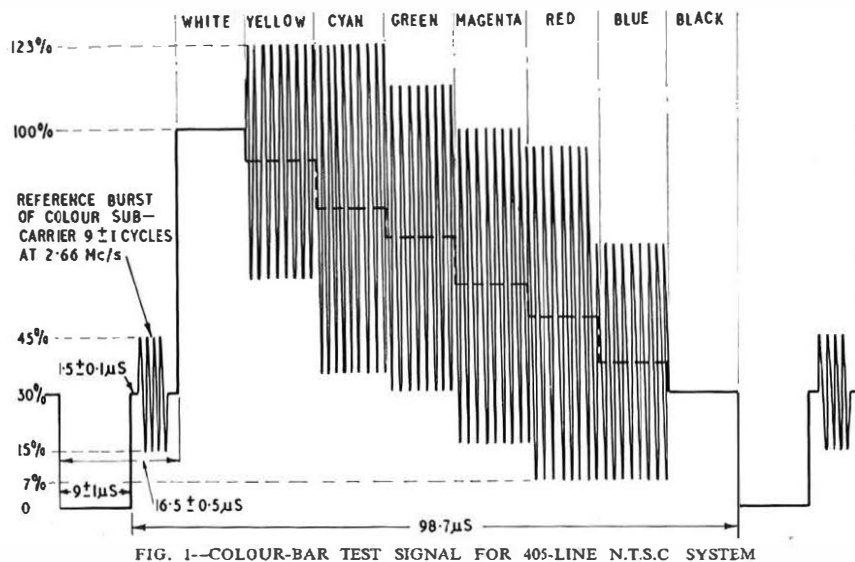

FIG. 1--COLOUR-BAR TEST SIGNAL FOR 405-LINE N.T.S.C. SYSTEM

quadrature on to a colour sub-carrier of 2.6578125 Mc/s (nominally 2.66 Mc/s) in the British adaptation of the American N.T.S.C. system.

Special Test Equipment

It is convenient to have a ready means of assessing the transmission qualities of colour equipment and circuits. The two items of specialized test equipment described below, the colour-bar signal generator and the Vectorscope, have been designed to meet the requirements of the modified N.T.S.C. system.

Colour-Bar Test Signal. Fig. 1 shows the line waveform of an electronically-generated colour-bar test signal (100 per cent saturated colours), used to assess the colour transmission quality of the circuits described later. In the transmitted signal, variations in hue appear as changes in phase of the colour sub-carrier relative to the reference burst, whilst variations in saturation, i.e. dilution of the colour by white, appear as variations of sub-carrier amplitude. As will be seen, colour sub-carrier is present at all levels of the luminance waveform, which takes the form of a staircase, even extending into the region below black level. Since a 2° change in phase of the sub-carrier, relative to the reference burst, can be detected in the picture under certain circumstances (see later), it can be seen that the differential phase and, to a smaller extent, the differential-gain characteristics, of a transmission system must be stringently controlled. In this context, "differential phase" is the term given to changes in the phase response of a transmission system relative to changes in signal level or system loading, whilst "differential gain" similarly relates the changes in gain of a system with changes in level or loading.

The Vectorscope. The Vectorscope^{5,6} provides, as its name implies, a display of the moduli and angles of the components of any signal from a still colour picture. It is used mainly in conjunction with the colour-bar test signal referred to above. Fig. 2 shows a photograph of the display obtained from such a signal; only the demodulated chrominance signals are displayed. The position and length of the vectors corresponding to the various colours are indicated by bright spots, as also are the origin and the reference burst. The remainder of the display, i.e. the lines connecting the dots, indicates the colour transients

at the edge of the various bars. Of particular interest is the 180° phase change between the green and magenta bars. Two cursors, one fixed and one moving, with a degree-scale on the outer edge of the fixed cursor, enable accurate amplitude and phase measurements to be made, whilst fixed tolerance-limit "boxes" for each colour provide a means of rapid assessment. The instrument includes a full range of display controls, and is a self-checking device with a high degree of accuracy.

OUTSIDE-BROADCAST CIRCUITS FOR COLOUR TELEVISION

The normal methods employed in the setting-up of vision circuits for television outside broadcasts have been described in earlier articles^{7,8,9}.

These methods have been successfully exploited for the provision of the connecting circuits for closed-circuit colour transmissions, though additional care is necessary with certain aspects of circuit performance. As far as the normal empirical methods of waveform testing allow, every effort should be made to maintain the band-width of the circuits. Ideally, the gain obtained at 10 kc/s should also be achieved at 2.66 Mc/s, the frequency of the colour sub-carrier, since any gain difference between these two frequencies results in distortion of the chrominance/luminance relationship of the picture being transmitted, i.e. the saturation of all colours is incorrect. Also, band-width limitation may affect the upper side-band of the chrominance channel and give rise to quadrature crosstalk between the two chrominance signals.¹⁰

The first television O.B. circuit for colour transmission was set up in January, 1956, as part of a demon-

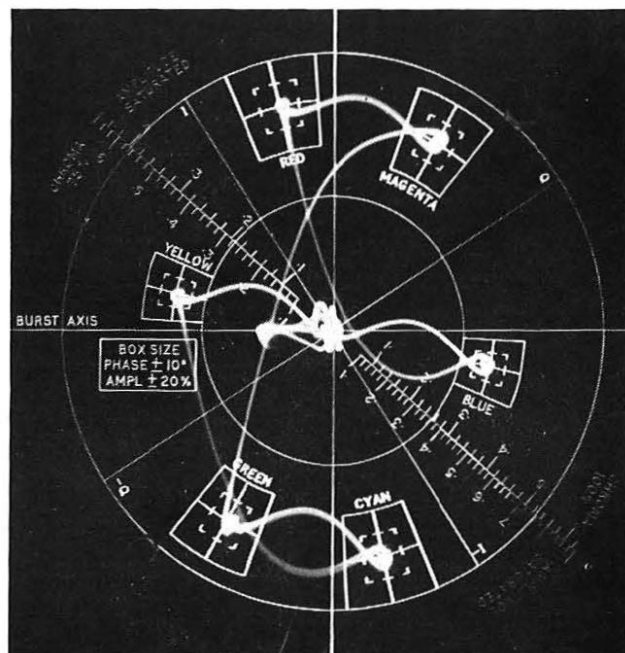

FIG. 2--VECTORSCOPE DISPLAY OF COLOUR-BAR TEST SIGNAL

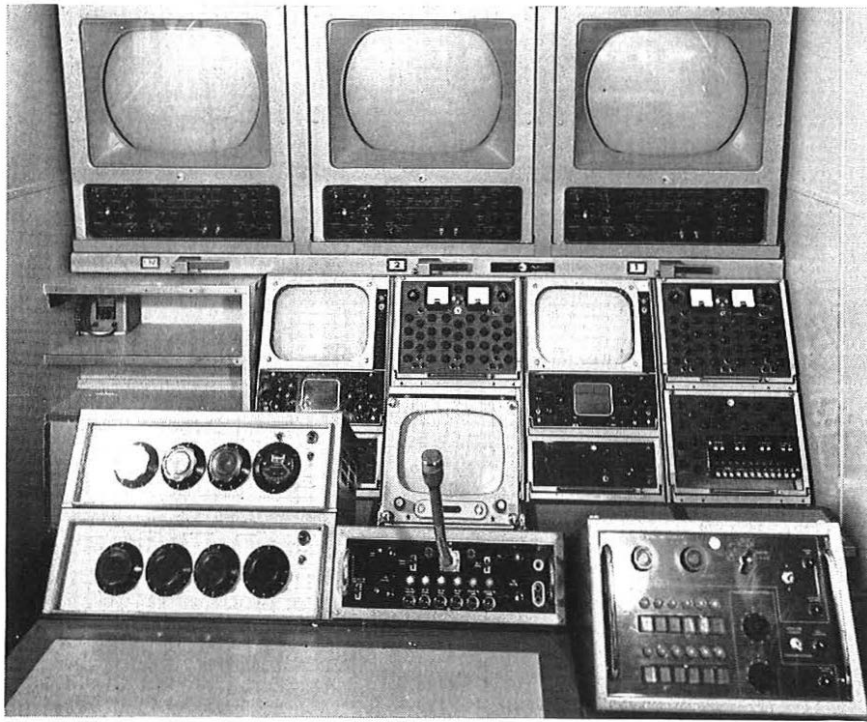

FIG. 3—LAYOUT OF CONTROL ROOM OF MOBILE MEDICAL COLOUR-TELEVISION UNIT

stration given to the C.C.I.R. Study Group XI at the Post Office Research Station, Dollis Hill, London. A loop circuit, 1.14 miles long, was provided consisting of one pair of 20 lb/mile telephone cable coiled on a drum and one O.B. video amplifier, so that the input and output signals could be directly compared. After careful alignment no distortion could be discerned on either colour test signals or still colour pictures.

In preparation for a series of medical colour demonstrations a similar looped circuit was provided in March, 1958, so that the practicability of transmitting colour signals over a telephone pair could be demonstrated to the potential user. The performance limits requested for this circuit are given in the table.

Performance Requirements for Closed Circuit
405-line N.T.S.C. Colour Television Signal Transmission

Test	Limits	Remarks
Waveform Response (2T)	K-rating factor $\geq 1\%$	Originally requested in terms of steady-state responses.
Differential Gain	± 1.0 db at 2.66 Mc/s	When the mean level of a small-amplitude signal is varied between the black and white levels.
Differential Phase	$\pm 2^\circ$ at 2.66 Mc/s	

The circuit, comprising 0.47 miles of $6\frac{1}{2}$ lb/mile P.C.T.D. (paper-core twin distribution) telephone cable pair and one O.B. amplifier, was tested and it was agreed that the requirements had been met. Colour measurements were made using the Vectorscope. It was also demonstrated, by maladjustment of the circuit so that a phase shift of 2° was produced in one of the colours of the colour test signal, that, under the special conditions of switching a colour monitor between the input and output of the circuit, colour distortion was just discernible on selected still pictures.

Reassured by this test a demonstration was arranged in Birmingham in July, 1958, to coincide with the British Medical Association's annual conference. Scenes from the Queen Elizabeth hospital were transmitted to the University Students Union building over a circuit of 1.0 mile of 20 lb/mile telephone pair and one O.B. amplifier. The circuit was used on eight consecutive days and gave an entirely satisfactory performance. A microwave radio link, provided as a reserve, was not used.

Circuits have since been provided for similar demonstrations in London on four occasions, Southampton, Edinburgh, Norwich, Torquay, Middlesbrough and Glasgow. Two of the circuits, the one in Southampton and one in London, were about 4 miles long and were equipped with four O.B. amplifiers. The Glasgow circuit, about 5 miles long, was equipped with five O.B. amplifiers. These three circuits met the $\pm 2^\circ$ limit for differential-phase distortion whilst the differential-gain distortion was of the order of 0.5 db.

LINEARITY EQUALIZERS

In some of the circuits a non-linear passive network was used experimentally during the setting-up operations. Essentially, this network consists of a variable attenuator and a phase equalizer section the characteristics of which, at black level and peak-white level, can be varied independently. Using the equalizer at the circuit output and employing the Vectorscope it was found possible to improve on the direct output of the colour-bar generator, which inherently has slight errors. In general, however, the circuits provided with the standard television O.B. amplifiers have been found almost free from differential non-linear effects, to the extent that the non-linear equalizer has not so far been used for transmission purposes.

THE MEDICAL COLOUR-TELEVISION UNIT

The mobile medical colour-television unit is self-contained, being provided with all the necessary facilities required for the production of a program. A vehicle with a specially-constructed air-conditioned body, divided into three compartments, houses a control room and an apparatus room in the central and rear compartments, respectively. The front compartment encloses the driving position and provides a limited amount of storage space. The layout of the control room is shown in Fig. 3. The top rack comprises three 21 in. colour monitors, the left-hand one being the outgoing line monitor, the other two being camera monitors. Below these are the picture and waveform monitors and camera control equipment. In the foreground is the producer's console with an $8\frac{1}{2}$ in. pre-view monitor, and the sound and vision mixing equipment. A control position for an industrial-type monochrome camera has been added below the line monitor since the photograph was taken.

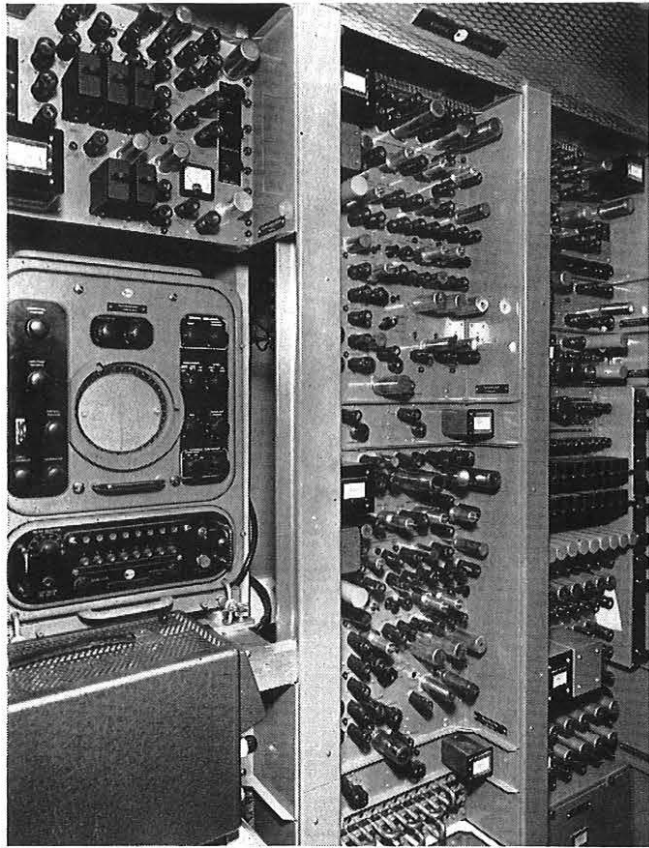

FIG. 4—PART OF APPARATUS ROOM OF MOBILE MEDICAL COLOUR-TELEVISION UNIT

Part of the apparatus room is shown in Fig. 4. On the left-hand rack is mounted the colour-bar signal generator and the Vectorscope, and on the central and right-hand racks are mounted the colour-signal generating, multiplexing and synchronizing equipment, as well as a vision-circuit patching panel.

Of the three cameras, two colour and one monochrome, now employed by the unit, one colour camera is set up in the operating theatre and, with the aid of a plane mirror, arranged to look vertically down on the operating table. This equipment, along with the normal theatre fittings, is made clinically sterile by the hospital staff, either by exposure to ultra-violet light or an antiseptic wash. The second colour camera is used with a portable studio and lighting equipment to televise a panel of experts, who describe and discuss the pre-operative and post-operative conditions of the demonstration subjects. The monochrome camera is used for captions.

At the receiving end of the circuit the picture signals,

which may be coloured or monochrome, are connected to the colour-television projection unit which provides an 8 ft × 6 ft picture that may be viewed comfortably by about 300 people.

Three audio circuits, two for sound and one for control, are normally required between the units and the viewing point. One of the sound circuits is used by the moderator for passing back to the panel and, if necessary, the surgeon, questions put by members of the audience.

CONCLUSIONS

An increasing demand for closed-circuit television transmissions is foreseen. This article has described what is thought to be a particularly interesting example using the modified N.T.S.C. colour system and the methods employed by the Post Office to provide the necessary point-to-point vision circuits.

ACKNOWLEDGEMENTS

The authors wish to acknowledge the assistance given during the preparation of this article by their colleagues in the various Regional television outside-broadcast teams, who collected much useful information, and by Mr. P. J. Edwards of the Inland Radio Planning and Provision Branch. The authors would also like to thank Smith, Kline & French Laboratories, Ltd., manufacturing pharmaceutical chemists, who sponsored the surgical demonstrations, and Marconi's Wireless Telegraph Co., Ltd., who manufactured the colour television equipment and kindly supplied the photographs of the apparatus in the mobile unit.

References

- ¹ HARTRIDGE, H. The Visual Perception of Fine Detail. *Philosophical Transactions of the Royal Society*, Ser. B, Vol. 232, May 1947.
- ² LAVER, F. J. M. Light, Colour and Colour Television. *P.O.E.E.J.*, Vol. 47, p.222 and Vol. 48, p. 22, Jan. and Apr. 1955.
- ³ HIRSCH, C. J. Principles of N.T.S.C. Colour Television. *Journal I.E.E.*, Vol. 2 (New Series), No. 14, Feb. 1956.
- ⁴ BROWN, G. H. Choice of Axes and Band-width for the Chrominance Signals in N.T.S.C. Colour Television. *Proceedings I.R.E.*, Vol. 42, No. 1, Jan. 1954.
- ⁵ PARKER-SMITH, N. N., and MATELY, C. J. The Vectorscope. *Electronic and Radio Engineer*, June 1957.
- ⁶ FISHER, J. F. Alignment of a Monochrome T.V. Transmitter for Broadcasting N.T.S.C. Colour Signals. *Proceedings I.R.E.*, Vol. 42, No. 1, Jan. 1954.
- ⁷ WILLIAMS, M. B., and SEWTER, J. B. The Provision of Circuits for Television Outside Broadcasts, Part I—Video Transmission on Telephone Line Plant. *P.O.E.E.J.*, Vol. 48, p. 166, Oct. 1955.
- ⁸ WRAY, D., and SEWTER, J. B. A Balanced Equalizer-Amplifier for Transmitting Video Signals over Telephone Lines. *Electronic Engineering*, Oct. 1955.
- ⁹ MACDIARMID, I. F. Waveform Distortion in Television Links. *P.O.E.E.J.*, Vol. 52, pp. 108 and 188, July and Oct. 1959.
- ¹⁰ BAILEY, W. F., and HIRSCH, C. J. Quadrature Crosstalk in N.T.S.C. Colour Television. *Proceedings I.R.E.*, Vol. 42, No. 1, Jan. 1954.

Notes and Comments

G. M. Mew, B.Sc.(Eng.), A.M.I.E.E.

Mr. G. M. Mew, who has been appointed Chief Regional Engineer in the London Postal Region, was educated at Portsmouth Secondary School and later at Portsmouth College, where he obtained a B.Sc. degree (First Class Honours) in 1929. After leaving college he joined B.T.H. at Birmingham; a year later he enrolled with Metropolitan Vickers at Manchester as a college apprentice and obtained useful experience in the firm's various workshops and laboratories. In 1932 he joined Messrs. Ferranti as a meter designer but a few months later returned to Portsmouth College as a lecturer in mechanical engineering. Whilst in this post he was successful in the 1932 Open Competition for Assistant Engineers (old style). His varied early experience undoubtedly proved of value in embarking on this new career in the Post Office.

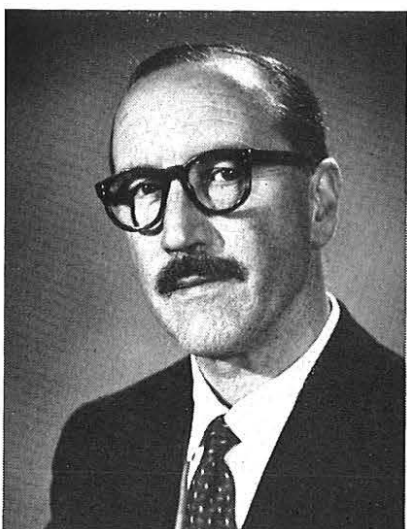

The first years of his Post Office service were spent on training at Dollis Hill, Canterbury and Croydon, and these were followed by a period as an Assistant Engineer in the Canterbury Section. In 1934 Mew had his first experience of Post Office power work when he was sent to the Power Branch for 6 months, and this was followed by a transfer to the technical section of the London engineering district to take up duties in the Power Group. He filled this post until 1940, when he was promoted to Power Engineer in the Home Counties Region. Regionalization had only just commenced at that time and Mew had the interesting but difficult task of organizing the power work and staffs in the Areas and at Regional Headquarters. This kept him fully occupied until 1949, when he left the Post Office to take up a post with a private firm specializing in the design and construction of conveyors and weighing and filling machines for the food and chemical industries.

After two years in outside industry he returned to Power Branch as Assistant Staff Engineer and was put in charge of the Section dealing mainly with the rapidly growing work of introducing mechanical equipment into Post Offices. During this time he was responsible for the engineering exhibits at the International Postal Mech-

anization Exhibition held in Rome in 1956, and in 1960 visited Oslo to advise the Norwegian Government on the layout of its new Oslo Letter Office. During his terms as an A.S.E., the letter-sorting machine, the segregator and letter-facing machines, and the parcel-sorting machine were being developed and manufactured, and his knowledge of these machines will be of great value to him in the L.P.R., where machines of these types will be introduced during the next few years.

Mew was popular with his own staff in the Engineering Department and with members of the Postal Service and other Departments with whom he had close contacts. His interest in mechanical aids has extended to his home where he has fully mechanized all his gardening operations. His friends in Power Branch are sure that he will carry out his new duties successfully and with him go their best wishes.

R. S. P.

Royal Signals Institution

Membership of the Royal Signals Institution has in the past been restricted to officers but it is now open to past and present members of the Corps of all ranks. The annual subscription is 15s., and membership application forms can be obtained from:

The Secretary, Royal Signals Institution,
88 Eccleston Square, London, S.W.1.

The object of the Institution is to foster the professional and technical interests of the Royal Corps of Signals, and its activities include the publication of the *Journal of the Royal Signals Institution*, the maintenance of the Royal Signals Museum, and the arrangement of Corps lectures and an annual essay competition.

Payment for the Journal by Deductions from Pay

The difficulties which delayed the introduction of the deductions-from-pay scheme have now been overcome and, commencing with the April issue of the Journal, all Post Office readers may arrange to pay for the Journal by deductions from their salaries or wages. This arrangement will not affect members of the Senior Section of the Institution of Post Office Electrical Engineers, whose membership subscription will continue to include the cost of the Journal. Associate Section members will be asked to complete two authorities for deductions from pay, one for their membership subscription and one for the Journal (see page 282 for further details). Journal Local Agents have forms available for completion by Post Office readers who are not members of the Institution.

Deductions from pay will be made at the rate of 10d. per month for monthly-paid staff, and at 3d. per week for 40 weeks each year for weekly-paid staff; the deductions will not start until the first pay day in April but, to facilitate the introduction of the scheme, readers are urged to let Journal Local Agents have their completed forms as early as possible and not later than 1 March.

Supplement and Model Answer Books

Students studying for City and Guilds of London Institute examinations in telecommunications are reminded that the Supplement to the Journal includes model answers to examination questions set in all the subjects of the Telecommunication Technicians' Course. Back numbers of the Journal are available in limited

quantities only and students are urged to place a regular order for the Journal to ensure that they keep informed of current developments in telecommunications and receive all copies of the Supplement.

Books of model answers are available for some telecommunications subjects and details of these are given at the end of each Supplement.

Notes for Authors

Authors are reminded that some notes are available to help them prepare the manuscripts of their Journal articles in a way that will assist in securing uniformity of presentation, simplify the work of the Journal's printer and draughtsmen, and help ensure that authors' wishes are easily interpreted. Any author preparing an article for the Journal who is not already in possession of the notes is asked to write to the Managing Editor to obtain a copy.

It is emphasized that all contributions to the Journal, including those for Regional and Associate Section Notes, must be typed, with double spacing between lines, on one side only of each sheet of paper.

Each circuit diagram or sketch should be drawn on a separate piece of paper; neat pencil sketches are all that are required. Photographs should be clear and sharply focused. Prints should preferably be glossy and should be unmounted, any notes or captions being written on a separate sheet of paper. Negatives or plates are not needed and should not be supplied.

Journal Binding

This issue completes Vol. 53 and readers wishing to have the volume bound should refer to page 294 for details of the facilities available.

Institution of Post Office Electrical Engineers

Associate Section

Subscriptions and Payment for the Post Office Electrical Engineers' Journal

Further to the notice in the October 1960 issue of the Journal (p.208), the accounting difficulties which necessitated the postponement of the introduction of the revised arrangements for deduction from pay have now been resolved and the new arrangement will commence on 1 April 1961. From that date there will be separate deductions from pay for Associate Section subscriptions and for the *Post Office Electrical Engineers' Journal*; for the national deductions-from-pay scheme for subscriptions, standard rates of 1d. per week or 5d. per month will apply.

A local centre with an existing local deductions-from-pay arrangement for subscriptions may elect to continue with the local arrangement or to participate in the national scheme. If the latter is selected, it will be understood that the standard subscription rates will apply.

Local centres who wish to vary the standard subscription rate and to remain in the national deduction scheme will be required to make their own arrangements to collect the difference from their members individually, outside the deductions-from-pay arrangement.

The deductions from pay for the Journal will be a national scheme and this cannot be varied.

Associate Section members will be required to complete fresh deductions-from-pay consent forms for the new arrangement. Supplies of the new forms will be sent to Local Secretaries who should arrange for their completion and transmission to local pay points.

Annual Awards for Associate Section Papers— Session 1959-60

The Judging Committee having adjudicated on the papers submitted by the Local Centre Committees, prizes and Institution Certificates have been awarded to the following in respect of the papers named:

First Prize of £7 7s.

J. L. Garland, Technical Officer, London Centre—
"Continental Semi-Automatic Switching Exchange."

Prizes of £4 4s. each

W. Sutton, Technical Officer, London Power Centre—
"Engineering Operations Involving the Post Office Railway at the new W.D.O., Rathbone Place."

P. R. Cheal, Technician I, Tunbridge Wells Centre—

"The A.N. and M.W. Party."

B. A. R. Cockett, Technical Officer, Tunbridge Wells Centre—"Metals."

J. S. D. Mitchell, Technical Officer, Aberdeen Centre—
"The Duties of Major Works Control."

In addition, the following papers, which were considered worthy of submission to the Judging Committee for the main awards, have been awarded a prize of one guinea each:

A. H. J. Towner, Technical Officer, London Centre—
"The Electronic Letter Sorting Machine."

W. C. Clark, Leading Technical Officer, Aberdeen Centre—"The A.T.E."

The Council of the Institution is indebted to Lt.-Col. F. N. Lucas and Messrs. D. C. Blair and L. A. Triffitt for kindly undertaking the adjudication of the papers submitted for consideration, and to Lt.-Col. F. N. Lucas, Chairman of the Judging Committee, for the following report:

In awarding the first prize to Mr. J. L. Garland for his paper on "Continental Semi-Automatic Switching Exchange," the committee has recognized the merit of a clear and well-laid-out description of the equipment recently installed in London for semi-automatic operation of circuits to Europe. The method of working and the facilities provided were lucidly explained.

The paper "Engineering Operations Involving the Post Office Railway at the new W.D.O., Rathbone Place" was a very competent account of a difficult civil engineering work of a type which is unusual in the Post Office. It described, in some detail, the main operations involved in providing a new station and re-routing the railway tunnel to serve a new District Office.

The paper "The A.N. and M.W. Party" gave a comprehensive account of the problems, the daily tasks and the equipment of a Minor Works gang. The subject was treated in an interesting way and suggested a keen personal interest on the author's part.

The paper "Metals," in dealing with the metals and alloys used in the Post Office, covered a very wide field and gave a useful description of the composition of metals, their properties and manufacturing processes.

The paper "The Duties of Major Works Control" reviewed the growth in volume and complexity of Post Office work which necessitated the establishment of Major Works Controls, and proceeded to give a very competent description of the duties and procedures of a Control.

S. WELCH,

General Secretary.

Regional Notes

Midland Region

USE OF EXPERIMENTAL PITCH-FIBRE DUCT AT RUBERY NEW A.T.E.

The level of the floor of the cable trench for the new automatic telephone exchange at Rubery is some 8 ft below the level of the public footpath. It was essential therefore that the lead-in should be watertight. It was known that the External Plant and Protection Branch were considering an alternative lead-in construction technique using pitch-fibre pipes and, after discussion, it was decided to use the method at this exchange as a trial.

Arrangements were made for the exchange manhole (TR8) to be built by contract; the duct was to be laid by direct labour. A "window" was left in the manhole wall that faced the exchange, and a similar window incorporating a p.v.c. water barrier was left in the wall of the new building.

Two prefabricated angle-iron frames were made to enable the duct-seal bolts to be positioned, and wooden templates were made for both ends of the duct line and fitted over the bolts on these frames. The vertical spacing of the ducts was 6 in. and the horizontal spacing was $5\frac{3}{8}$ in. between centres.

The lead-in was about 13 ft long and due to this, and the slope of the ground, working conditions were far from good for the manhole-building party and the duct-laying gang. An added difficulty was the wet weather on the first day. The operation was spread over a period of $3\frac{1}{2}$ days; on the first day the manhole-building party excavated a trench along the line of the duct, provided shuttering and laid a 6 in. thick reinforced-concrete base (1 : 2 : 3 mix). In this base the $\frac{1}{2}$ in. diameter mild-steel rods, to take the spacers for the ducts, were set to a depth of 1 in. along the line of the ducts to support the ducts at regular intervals. It was necessary for the positioning of these rods to be such that when the ducts were laid with the joints staggered, each duct would be supported at a point not more than 3 in. from the joint.

On the second day the shuttering for the base was struck and the laying of the ducts carried out. The joints consisted of spigot taper joints coated with sealing compound before being driven home. The duct was easily cut to length with a carpenter's saw; this enabled the joints to be staggered. The end ducts were also cut to the correct angle to suit the fall of the duct line.

The third day's work consisted of completion of the block. Shuttering was erected to give 3 in. cover of concrete over the ducts, and concrete (1 : 2 : 3 mix) was poured between the pipes in 6 in. layers. Each batch was vibrated, using a 1 in. poker. The shuttering was removed the following day.

Subsequent inspection showed that the work had been satisfactorily completed. A pressure test was carried out on three of the 12 bores, each of which held an air pressure of 4 lb/in², which is the equivalent of an 8 ft head of water. Officers from the External Plant and Protection Branch were present throughout the operation to give advice and to gain experience in the new technique.

K. G. S. A.

BIRMINGHAM CABLE TUNNEL

It had been known for some years that Birmingham Corporation were planning a large traffic roundabout in Snow Hill, some 600 yd from Telephone House, but it was not until early in 1959 that detailed plans were received. These plans showed a number of pedestrian subways and a vehicle underpass, which meant that all existing cables would have to be diverted to a new route not less than 35 ft below the existing road levels. Moreover, once the structure of the roundabout was completed, later instalments of cable track could only be provided by tunnelling. Changes in existing ground levels were also on such a scale that it was im-

practicable to lay ducts except at very exceptional depths.

A cable tunnel was clearly the only way of overcoming all the problems set by this roundabout and, with another section of tunnel needed at Telephone House, it proved to be economical, and structurally sound, to construct a continuous tunnel about 700 yd long, between the new lead-in to Telephone House and a point in Shadwell Street clear of the Snow Hill roundabout. The tunnel is 7 ft in diameter with 10 ft enlargements at the two ends, and has a capacity for 120 full-size cables.

In addition to the foregoing requirements, developments in the provision for broadband-radio trunk communication together with the need for expansion of the Birmingham television switching centre, made it necessary to re-examine the cable lead-in arrangements at Telephone House. It was evident that the existing cable chamber and its lead-in ducts would not suffice for the expected increase in new h.f. cables, and it was not well sited in relation to the new h.f. repeater station and television switching centre. Furthermore, provision had to be made in the future for a second 10,000-line director exchange. In consequence a light-well at Telephone House was roofed in and converted into a double-deck cable chamber for coaxial and composite coaxial-and-audio cables. The floor level of the existing cable chamber was 30 ft below the level of the footway so that tunnelling was necessary to link the existing chamber to the new cable chamber. This tunnel was designed as an extension to the tunnel mentioned above.

Because of the time limit set by the road works at Snow Hill, the tunnel with its shafts and special turning chambers had to be completed in six months, and to make this possible three shafts were sunk and horizontal excavation proceeded on three faces simultaneously. The main working shaft was on a vacant site belonging to the Post Office, one was in the carriageway beside Telephone House, and the third in Shadwell Street, where there is to be an in-fill of about 15 ft to bring the ground up to the new carriageway level. The shaft-head there is, consequently, partly above the present ground level pending the in-fill. The circular shafts were formed from cast-iron segments whilst the roughly circular-section tunnel is of concrete without reinforcement.

For the majority of its length, the tunnel lining was cast in position with the aid of a special mobile form arranged to be advanced manually after each section of concrete had set. In one section of tunnel, soft sand was encountered so the tunnel was first lined with precast-concrete segments bolted together, and then grouted on the outside with neat cement injected under pressure. A further concrete lining was then cast inside the segments by means of the mobile form.

Provision has been made for lighting and ventilating the tunnel and for pumping out any seepage water. Forced ventilation was also required in the basement of Telephone House to replace the natural ventilation which was blocked by the roofing-in of the light well.

E. W. A.

Northern Ireland

AN AUTOMATIC STEAM-HEATING SYSTEM IN BELFAST

Premises recently acquired by the Telephone Manager of Belfast for an engineering centre included a low-pressure steam-heating installation. The maintenance of this installation involved full-time attendance for stoking. It was decided, therefore, to convert the boilers to automatic oil firing. Such a procedure is recognized as satisfactory if there is a double check on the level of the water in the boilers; if the final low-level is reached the installation must shut down and await manual attention. The condensed steam is normally returned to the boiler by a condensate return-pump, but variations in level can occur while the

installation is starting up and under these conditions the steam pressure is not adequate to return the condensate to the pump.

Normal working of the boilers relies on supervision by a "pressure-stat." When full working pressure is obtained the oil burners shut down and then re-start when the reduction of pressure exceeds the working differential of the pressure-stat. Should the pressure-stat fail to cut off the oil burners the safety valves are capable of relieving the boiler of excess steam without a dangerous pressure being attained.

Automatic control of the room temperature is provided by reference to an external thermostat. This thermostat is arranged in such a manner that when steam heat is being supplied to the building, electric heat is supplied to the external thermostat. By an initial adjustment of this current the heat-loss of the external thermostat can be made to simulate the heat-loss of the building. When the external thermostat operates the oil burner shuts down and re-starts when the thermostat has cooled sufficiently for its contacts to re-make.

J. L. F.

North-Eastern Region DONCASTER MOTORWAY

The Doncaster motorway will, when completed, by-pass Doncaster on the west side and do much to alleviate the traffic congestion in the town. Starting at the Humber Head bridge, north of Doncaster on route A1 where the road crosses the King's Cross-Leeds main railway line, the motorway extends $12\frac{1}{2}$ miles southwards to finish at Blyth. In between these two points, 32 bridges will have been built and Post Office plant is affected at 14 of them.

Access to the motorway is obtainable only from two intermediate points. At both places a 4-way duct track has been laid across the west-side slip roads. Along all bridges over which the motorway passes, a nest of four steel pipes has also been laid. In case it is necessary to provide emergency telephones, ducts have been laid across the motorway at 1-mile intervals.

One of the major projects has been the construction of a roundabout and the four associated slip roads on the Doncaster-Sheffield route, A630, at Warmsworth. The motorway passes beneath the roundabout and this has resulted in the roundabout being built as two separate bridges, one for each direction of traffic. The old road ran between these two bridges and the telephone plant along it consisted of one 4-way and two 2-way ducts containing the four Doncaster-Sheffield trunk cables and five local cables.

Before the old road could be dug out, the southern bridge of the roundabout had to be built and traffic diverted to it. During the building of this bridge the existing duct-track was excavated and a narrow suspension bridge built so that its cat-walk floor was beneath the track. Thus, when the motorway contractor continued to excavate, the old road was completely removed and the bridge and its cables were left some 30 ft above the motorway surface. To lighten the load on the suspension bridge the 4-way duct and one of the 2-way ducts were removed.

The second bridge was then built and during construction twelve 4 in. steel pipes were laid across it. A duct-track of two 6-way ducts was provided from each side of this bridge to join up with the existing track. The work also involved the construction of five R2A manholes. On completion of the new track, cables were laid and circuits diverted into them. Finally, the old cables and the suspension bridge were removed.

Wales and Border Counties HOSPITAL TELEPHONE TROLLEY

A telephone trolley was recently presented to the Wrexham War Memorial Hospital on behalf of Post Office engineering, operating and postal staff at Wrexham and in the surrounding district. A view of the trolley, which was designed and made by the local engineering staff, is shown in the photograph.

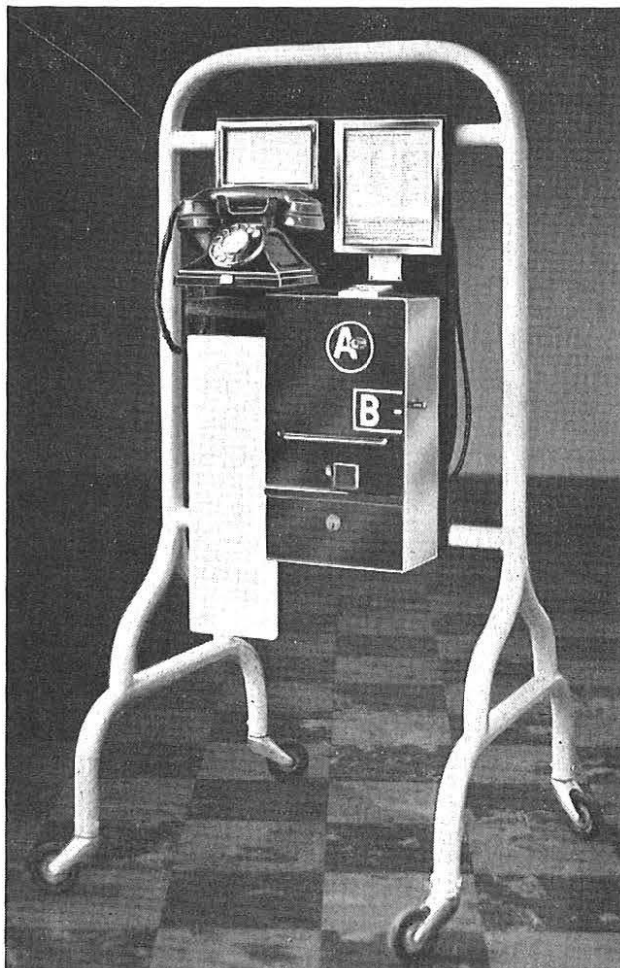

TELEPHONE TROLLEY FOR WREXHAM HOSPITAL

Light-weight 1 in. mild-steel tubing was used to make the frame, which has overall dimensions 3 ft 8 in. \times 1 ft 11 in. A standard wallboard fitted to the two cross-members supports the telephone and coin-box. The wallboard has been drilled so as to take both the present prepayment type and the new pay-on-answer coin-box. A hinged shelf 18 in. \times 6 in., shown clearly in the photograph, can be used for writing purposes during a telephone conversation.

At the rear of the backboard are fitted the directory holder and hooks on which to store the rubber-covered connecting cable.

K. G.

Associate Section Notes

Stoke-on-Trent Centre

The 1959-60 session was another successful one, during which we had some excellent lectures. On 21 October 1959, Mr. Knox lectured on "Appraisements and Promotions." This lecture was attended by the record number of 58 members, who all enjoyed a most interesting and, at times, amusing evening. Mr. Knox was obviously the master of his subject. On 11 November 1959, Mr. Macgregor Clarkson, the Stoke-on-Trent stipendiary magistrate, gave a talk on "Some Court Work." Mr. Clarkson's excellent subject, coupled with his dry sense of humour, made a very interesting evening. He left the thought in our minds that justice was tempered with mercy. On 9 December 1959, Mr. Ede gave a lecture on "Tracing Noise on Program Circuits." Mr. Ede, who is a member of the Stoke-on-Trent Centre, based the talk on his I.P.O.E.E. prize-winning essay of the same title.

On 15 January 1960, a meeting was held for the first time at Crewe, when Mr. Dimelow of Shell Mex and B.P., Ltd., introduced films on "Oil Transport and Refining." On 19 February 1960, Messrs. Beardmore and Peake of the Central Training School, Stone, gave lectures on "S.T.D." and the "Pay-on-Answer Call Box," respectively. These topics were particularly interesting as both items will be introduced in the Area when the Stafford automatic telephone exchange opens in July 1961. On 23 March 1960, Sgt. Sandall of the Stoke-on-Trent City Police Force gave a talk on "Police and the Public." This told us something of police methods, and reminded us that the policeman is only human, and that he too has his Monday mornings.

The annual general meeting was held on 27 April 1960, and the following officers were elected for the ensuing session: *Local President*: Mr. H. Todkill (Telephone Manager); *Chairman*: Mr. A. E. Paterson; *Vice-Chairman*: Mr. A. E. Fisher; *Secretary*: Mr. A. E. Foden; *Librarian*: Mr. C. Price; *Committee Members*: Messrs. C. Bennion, D. J. Astley and W. Roberts; *Auditors*: Messrs. A. S. Bardill and R. F. J. Missen.

The following visits were also arranged during 1959-60. On 23 July 1959, 30 members visited the steel works of John Summers & Sons, Shotton. This was a most interesting visit and we were afterwards entertained to an excellent supper in the works canteen. On 7 June 1960, 22 members paid a full-day's visit to the oil refinery of Shell Mex and B.P., Ltd., at Stanlow. This was an entertaining day, both from the technical side of oil refining and from the lavish hospitality shown to our members.

Plans for the 1960-61 session include a joint lecture from two of our members, Messrs. Gee and Clarke, on the "Cordless switchboard," a lecture from Dr. Davies of the University College of North Staffordshire on "Energy from the Atom," a lecture from Dr. Coombs of the P.O. Research Station on "Speech Interpolation," and a lecture from Mr. Brasher of the Sheffield Centre on "Tape Recorders." Other lectures and film shows are being planned.

A. E. F.

Dundee Centre

Our 1960-61 session opened with a very successful outing to the North of Scotland Hydroelectricity Board's control centre at Port-na-Craig House and the Brown Trout Research Station, both at Pitlochry, on Saturday, 10 September. On 29 September, 25 of our members and friends saw the intricacies of glass working at the Moncrieff Glass Works, Perth.

Then, on 20 October, we visited the Tay tidal model and, on 10 November, the printing works of John Leng & Co. These completed the visits for this session—an arrangement that was decided on in an attempt to beat the weather, which, in the past, has forced us to cancel many of our visits.

On 29 November, Mr. J. R. S. Lawson gave a talk on

"Microwaves for the Layman," and on 13 December, Mr. D. L. Miller, Junior, spoke on "New Sub's Apparatus." The remainder of our program is as follows:

17 January: "Pulse Testing," by Mr. R. B. Duncan.

23 February: "Tape Recorders," by Mr. D. Cook.

March: "Outside T.V. Broadcasts," by Mr. W. K. Johnson, from Edinburgh.

April: Annual general meeting.

The actual dates of the last two meetings will be fixed in the new year. J. S. B.

Aberdeen Centre

The 1960-61 session commenced with a visit to the Marine Laboratory, Aberdeen. The laboratory staff is engaged in research work in association with the fishing industry, and underwater photography and electronic equipment are used extensively in this work.

Meetings on "S.T.D." were held at Aberdeen and Inverness in September. Members of the Traffic staff summarized the traffic aspects of S.T.D. and this was followed with an outline of the circuits by Associate Section members. At Aberdeen, a member of the senior section of the I.P.O.E.E. concluded the meeting with a review of future development and transmission problems. At Inverness, members and guests were shown round the recently-installed S.T.D. equipment. The attendances were, including guests, 52 at Aberdeen and 33 at Inverness.

Other meetings held during 1960 were as follows.

At Aberdeen: "Hi-Fi" and "Astronomy," by Associate Section members, and "Work Study" by a guest speaker.

At Inverness: A film show, when films on "Transistors" and other technical subjects were presented. J. G. P.

Ipswich Centre

Following a very successful winter program, members of the Ipswich Centre paid a visit to London Airport in May. A complete tour of the airport was arranged, and a detailed description of the organization and working of this vast undertaking was given. Members were greatly impressed and the visit was thoroughly enjoyed by all.

The visit in June was to one of our local factories, Churchmans, Ltd., where members saw the manufacture of cigarettes and pipe tobacco from the "leaf" stage to the finished article. Packeting and dispatching proved to be of great interest, and the machinery used was one of the outstanding features.

The plastics industry provided a most instructive evening visit in July, when we visited B.X. Plastics, Ltd., at Brantham. The raw material for making plastic articles is the main output of this factory, and only a few actual articles are made; photographic film is made at an adjoining premises. It was apparent to members that the demand for plastic materials is ever increasing and their uses are unlimited.

In August a visit was arranged to the Mendlesham station of the Independent Television Authority, which transmits Anglia Television programs. Members saw the part played by the Post Office in providing the television circuits necessary to feed the I.T.A. transmitters, and much interest was shown in the equipment associated with these "links." The transmitters and control room were most impressive and proved instructive to all. The greatest interest was aroused by the 1,000 ft aerial mast, and members appreciated the details given on the construction of this mast. We are indebted to the I.T.A. for a most instructive and enjoyable evening.

A further all-day visit in September was to the cable factory of Standard Telephones and Cables, Ltd., at Woolwich, where the manufacture of underground cable, as supplied to the Post Office, was seen and described in detail. Members were shown methods of testing completed

cables and were left in no doubt as to the stringency of these tests to ensure minimum fault liability. It was apparent that the highest possible standards are maintained to ensure a satisfactory product.

The September visit concluded our summer program, and we look forward now to what should prove a most enjoyable winter session.

E. W. C.

London Centre

Our 1960-61 session was inaugurated in September at the London Planetarium with the now customary open meeting. Our members, their families and friends filled the Planetarium to its capacity of 555 seats to hear Dr. H. C. King, the Chief Astronomer, present "D-Day for Space," an exciting introduction to the solar system and heavens from the viewpoint of the space traveller. The contribution made by satellites in the exploration of space was considered and also the problems of landing on the moon, our nearest neighbour. The heavens were then advanced very rapidly, with amusing results, to show how the sky would appear in 1970 to a traveller about to embark on a space voyage. The latter part of Dr. King's talk was devoted to an explanation of some of the more interesting aspects of the wonderful Zeiss projector. To complete the evening the Planetarium organizers generously arranged a private viewing of Madame Tussaud's waxworks, which many of us had not visited for years. We were privileged to have as guests for the evening Mr. L. G. Semple, Mr. W. S. Procter, our President, Mr. A. H. C. Knox and Mr. L. F. Salter, Staff Engineer, Telephone Exchange Standards and Maintenance Branch, Engineering Department.

For the talk in October, "The Recording of Brain Potentials," we were indebted to Mr. A. J. Smale, Mr. P. J. Reynolds (formerly with A.E.I. (Woolwich), Ltd.), and Mr. A. C. Johnstone of A.E.I. (Woolwich), Ltd., who kindly provided the demonstration equipment. Mr. Smale talked about the electrical design of the electro-encephalograph while Mr Reynolds discussed the medical aspects of the subject. The electrical activity of the brain of a member of the audience was then recorded while the heart performance of another was recorded on a transistorized electro-cardiograph. Other equipment shown during this most interesting evening was an electrical equivalent of the stethoscope and some electrodes of the type used for stimulating the surface of exposed areas of the brain.

In September, North West Area ran their first annual dance, which was supported by about 250 people. In October, Messrs. B. B. Gould, S. H. Sheppard, of the Telephone Exchange Systems Development Branch, and Mr. B. F. Yeo, of the Telephone Exchange Standards and Maintenance Branch, Engineering Department, kindly repeated their talk "S.T.D. as it Affects Director Exchanges" to some 50 of our members in North Area at Potters Bar Exchange.

By the time these words are read the opening rounds of a further inter-area technical quiz will have been played. Eight Areas have entered teams this session in the contest for the Quiz Shield. After the final in last session's contest, it was decided to arrange a match with Brighton Centre and this was held on 11 November, when a composite team of three members from each of last session's finalists, West and City Areas, met the Brighton team in the Telephone Manager's Office at Brighton.

Reports from the Associate Section Regional Liaison Officer's Conference held at Stone last October indicate that the proposed Associate Section tie, introduced by the London Centre, has been favourably received, and it is hoped that it will be adopted nationally. The price has now been fixed at 8s. if purchased individually, or 7s. 6d. for an order of a dozen or more. Information sheets about the tie have been circulated to all Regional Liaison Officers throughout the country.

D. W. W.

Leeds Centre

The 1960-61 session got away to a very good start on 15 September with a most interesting and instructive talk on "Two New Electronic Circuit Devices," given by Mr. C. A. May, of the Telephone Exchange Systems Development Branch, Engineering Department.

The talk was very well illustrated with several demonstration sets and slides. A lively discussion took place afterwards.

This meeting was the final meeting presided over by Mr. C. Baker before his move to the Engineering Department. Whilst we all wish him the very best in his new job we are sorry to lose such a good worker. Without him the Leeds Centre, I am sure, could never have had so many grand outings and talks.

Our next visit takes 30 of our members to Pyc Telecommunications, Ltd., of Cambridge.

I. A.

Sheffield Centre

During July we visited the Doncaster works of International Harvester, where both wheeled and crawler types of tractor are made in various sizes from 55 to 124 horsepower. Unfortunately, at the time of our visit evening shifts were being worked only in the foundry, but in spite of this, our guides managed to make the trip very interesting.

Our destination on 10 August was the Ferranti Works at Oldham, where the principal products are silicon semiconductor devices. We saw the manufacture of silicon diodes from the making of the silicon crystal to the final testing, and learnt from our excellent guides about the problems involved in the development of new manufacturing techniques. We also saw television cathode-ray tubes being made on a semi-automatic production line, and instrument tubes being hand-made. In the showroom, there was a display of the firm's products, and some interesting demonstration models that showed the application of other silicon devices, including photo-voltaic cells, photo-electric cells, and voltage-variable capacitors.

We went to Doncaster again on 18 August, this time as guests of the local Centre, to take part in a visit to the Doncaster motorway. Despite the inclement weather the trip proved extremely interesting, and we are grateful to our Doncaster colleagues for their invitation and to the motorway contractors for their excellent hospitality.

The winter session was given an excellent start on 14 September by Mr. R. L. Bull Principal Scientific Officer, Materials Section, Test and Inspection Branch, Engineering Department. He spoke to us about various aspects of the work of this section, whose main job is to test the various materials used by the Post Office. Complaints about materials are also investigated, and the section acts in an advisory capacity when specifications are being prepared. As Mr. Bull pointed out, it is no use including an item in a specification if you cannot test for it in the finished product. After outlining the history and functions of the section, the speaker mentioned a number of particularly interesting investigations that had been carried out, and illustrated them with lantern slides. Fortunately, our Chairman had allowed a liberal amount of time for questions, for almost every member of the audience had at least one to ask.

J. E. S.

Scunthorpe Centre

On the evening of 4 October 1960, members of the Scunthorpe centre were hosts to colleagues from Lincoln, Grimsby and Doncaster. The meeting opened with the formal presentation of Institution certificates by the Chief Regional Engineer, Lt.-Col. J. Baines. The certificates were awarded for the prize-winning essays "A Decade of Interference Investigation Duties" by Mr. Burkitt and "Atoms and Magnets" by Mr. Clark.

The presentation was followed by a talk on "Appraisements and Promotions" by the Associate Section President, Mr. A. H. C. Knox. With the aid of slides he explained in detail how the Department's promotion procedure works. Mr. Knox took his audience behind the scenes of a promotion board to show how appraisements are used, and how boards try to ensure that comparisons between men are fair, not only in the same area but in other areas also, so that the right man is promoted to the right job.

The program from January onwards is as follows:

12 January 1961: "Optical Aids to Development and Maintenance," by Messrs. E. W. Hubbard and G. L. Mack, Telephone Exchange Standards and Maintenance Branch, Engineering Department.

8 February 1961: "American Phone Methods," by Mr. E. Hopkinson, Area Engineer, Leeds.

8 March 1961: "Telephone No. 706," by Mr. H. J. C. Spencer, Subscribers' Apparatus and Miscellaneous Services Branch, Engineering Department.

12 April 1961: Annual general meeting and social evening.
H. V. P.

Cornwall Centre

In July an evening visit was made to the Ministry of Agriculture Experimental Station at Rosewarne and an interesting evening was spent among the many acres of experimental crops.

We were fortunate to have an invitation to attend a Mollard lecture in August and our members had an enjoyable evening. Also in August we visited the Holmans Engineering Works Museum where many historical steam engines, mainly from the old Cornish mines, are preserved. Following this visit our members were invited to spend a day at Holmans Works and this proved to be very popular.

The 1960-61 session commenced with a paper by one of our members, Mr. D. Rosevear, on "Do it Yourself House Building." Mr. Rosevear recently built his own bungalow

and was able to give members his experience in the various stages from planning to completion.

We were very fortunate to have Mr. W. S. Procter, O.B.E., Chief Regional Engineer, London Telecommunications Region, to give us a paper on "The Electronic Register-Translator using the Magnetic Drum" for our October lecture. This is the first Centre to have this lecture from Mr. Procter and we are very proud of this honour. Mr. Procter was assisted by Mr. Paynter.

Col. Hall, Area Engineer, Plymouth, gave the Centre a paper on "External Construction—Fact and Fiction" in November. We also held our annual dinner in November.

A. R. B.

Reading Centre

At a preliminary meeting held during September, 15 people met in Reading under the chairmanship of the Area Liaison Officer, Mr. Rawling. The meeting decided to form an Associate Centre at Reading and followed up their decision by electing a committee.

Mr. E. W. Weaver, the Telephone Manager, was invited to become President of the Centre and the officers elected were: *Chairman*: Mr. H. R. Merry; *Vice-Chairman*: Mr. L. Simmons; *Honorary Secretary*: Mr. S. H. Ward; *Treasurer*: Mr. P. Bennet.

The inaugural meeting was held on 3 October 1960, when Mr. Knox, President of the Associate Section, read his paper, "Appraisements and Promotions." By the date of this meeting, and with only moderate effort, the membership had grown to something over 90, a fact which gave great satisfaction to the original 15. During the evening Mr. Knox presented an award to Mr. R. L. Wood, gained in the essay competition; this is Mr. Wood's second success in this competition.

A program of meetings has been arranged on a variety of subjects for the current session, and the committee are now working on a more ambitious program for next winter.

H. R. M.

Book Reviews

"Tensors for Circuits." Second Edition. Gabriel Kron. Dover Publications, Inc., New York, and Constable & Co., London. xxvii + 250 pp. 153 ill. 15s.

Gabriel Kron has the distinction of being the world authority on the application of tensors to electrical engineering. For nearly 30 years he has been publishing an almost continuous stream of papers, monographs and books on the subject and, in the process, has become a controversial figure akin to Heaviside. He has been abused by mathematicians for misusing their tensor analysis and rejected by electrical engineers for treating an apparently simple problem with unnecessarily difficult mathematics. The reason lies partly in the novelty of his ideas and partly in his style of writing, which often impresses the reader with the thought that the author wishes him to be impressed. Nevertheless, current informed opinion is that Kron's work deserves more respect than it has so far received: time alone will reveal its true merit.

The present book is a paperback republication of a volume originally published in 1942 under the title "A short course in tensor analysis for electrical engineers." It contains an introduction to the author's tensor theory of stationary electrical networks and of rotating electrical machines. As the subject goes it is an elementary treatment, but at the best of times it can hardly be regarded as an easy subject and the intending reader must be prepared to do a lot of hard thinking. Of the four books which the author has written it is probably the best choice for the beginner, although for students of communication engineering it has the mild drawback of containing examples taken exclusively from the realm of the power engineer.

It is not a book to be recommended to the faint-hearted or those with a practical outlook on life—but if you have a passionate interest in circuit theory, a good knowledge of mathematics, and a year or two to spare, then this is just the book for you.

H. J. O.

"Transistors—Circuits and Servicing." B. R. A. Bettridge, M.Brit.I.R.E. Trader Publishing Co., Ltd. 27 pp. 17 ill. 3s.

This book was first published in 1957 and is now republished, slightly enlarged, in its second edition. It is written for the radio servicing engineer who requires an elementary introduction to the use of transistors in domestic radio receivers and amplifiers, and it consists mainly of descriptions of the operation of typical circuits.

The author describes the electrical behaviour of the transistor and its application in grounded-base and grounded-emitter amplifiers. He then goes on to consider typical audio-frequency amplifiers, including class B output stages. A chapter on domestic radio receivers follows, including a short section on v.h.f. receivers for f.m. signals. The final chapter deals with simple methods for testing transistors and stresses the precautions necessary to avoid damaging transistors while tracing faults.

There is one minor criticism: the beginner might gain the impression on reading pages 9 and 10 that all transistors ought to have an alpha value of 0.98.

Despite its small size, the book covers considerable ground, and is useful as an elementary introduction to transistor circuits.

H. G. B.

I.P.O.E.E. Library No. 2622.

Staff Changes

Promotions

Name	Region, etc.	Date	Name	Region, etc.	Date
<i>Assistant Staff Engineer to Chief Regional Engineer</i>			<i>Inspector to Assistant Engineer—continued</i>		
Mew, G. M.	E.-in-C.O. to L.P. Reg.	24.10.60	Gordon, J. A. E.	H.C. Reg.	20.6.60
<i>Area Engineer to Regional Engineer</i>			Gilbert, L. M.	H.C. Reg.	1.7.60
Probert, G. A.	Mid. Reg.	1.9.60	Wilson, R. G.	H.C. Reg.	18.7.60
<i>Senior Executive Engineer to Assistant Staff Engineer</i>			Colman, D. R. F.	H.C. Reg.	1.7.60
Hayward, R. K.	T.S.U.	1.9.60	Barnes, W. V.	H.C. Reg.	18.7.60
Bampton, J. F.	E.-in-C.O.	1.9.60	Moody, G.	H.C. Reg.	20.7.60
Williams, M. B.	E.-in-C.O.	8.9.60	Barrell, J.	N.E. Reg.	7.7.60
<i>Executive Engineer to Senior Executive Engineer</i>			Tait, A. H.	L.T. Reg.	3.8.60
Eagle, R. J. A.	L.T. Reg.	27.6.60	Pagan, A. B.	L.T. Reg.	3.8.60
Bennett, T. J.	E.-in-C.O.	23.6.60	Bath, R. E.	L.T. Reg.	25.8.60
Green, L.	E.-in-C.O.	23.6.60	Parfitt, W. G.	L.T. Reg.	3.8.60
Martin, F. N.	E.-in-C.O.	23.6.60	Innes, J.	Scot.	5.9.60
Ingram, E. A.	E.-in-C.O.	23.6.60	Haines, H. J.	W.B.C.	12.9.60
Rata, S.	E.-in-C.O.	23.6.60	Erratt, R. J.	L.T. Reg.	25.8.60
Bubb, E. L.	E.-in-C.O.	8.8.60	Thomas, H.	N.W. Reg.	30.9.60
Stoate, K. W.	E.-in-C.O.	8.8.60	<i>Technical Officer to Assistant Engineer</i>		
Allen, A. F. G.	E.-in-C.O.	22.8.60	Parker, S. V.	S.W. Reg.	29.6.60
Edwards, P. J.	E.-in-C.O.	12.9.60	Spicer, J. H.	S.W. Reg.	18.7.60
Gauntlett, R. D.	E.-in-C.O.	12.9.60	Robertson, J.	Scot.	1.7.60
<i>Executive Engineer (Open Competition)</i>			Hayes, W. T.	E.T.E.	28.6.60
Whittington, K. W. H.	E.-in-C.O.	15.9.60	Sturgeon, E. D.	N.I.	1.6.60
<i>Executive Engineer (Limited Competition)</i>			Lockyer, K. S.	E.-in-C.O.	21.7.60
Jennings, P. A.	N.I.	28.3.60	Walker, R. W.	E.-in-C.O.	21.7.60
<i>Assistant Engineer to Executive Engineer</i>			Hooker, R. H.	E.-in-C.O.	19.7.60
Michie, P. G.	Scot.	4.7.60	Chamberlain, I. C.	E.-in-C.O.	21.7.60
Bentley, A.	N.W. Reg.	1.6.60	Grear, C. N.	E.-in-C.O.	21.7.60
Morgan, M. T.	Mid. Reg.	4.7.60	Hill, R. A.	E.-in-C.O.	21.7.60
Bailey, G. W.	H.C. Reg.	11.7.60	McKechnie, N.	E.T.E.	20.7.60
Arnoll, E. R.	N.W. Reg.	23.6.60	Malcolm, G. T.	E.T.E.	4.7.60
Wills, C. P.	H.C. Reg.	4.7.60	Cornick, R. E.	E.T.E.	28.6.60
Fagg, S. L. F.	H.C. Reg. to E.-in-C.O.	27.7.60	Taylor, L. W.	Mid. Reg.	4.7.60
Kynaston, J. A. C.	W.B.C.	7.8.60	Steele, J. A.	S.W. Reg.	19.7.60
Thomas, E. B.	Mid. Reg.	10.8.60	Wade, P. H.	N.E. Reg.	7.7.60
Newsham, J.	N.W. Reg.	25.7.60	Jones, P. D.	E.-in-C.O.	22.7.60
Farmer, R. M.	N.W. Reg.	20.7.60	Jack, G. W.	Scot.	7.7.60
Parker, J. N.	N.E. Reg.	20.7.60	Chick, J. V.	E.-in-C.O.	22.8.60
Daynes, F. W.	L.T. Reg.	12.8.60	Wotherspoon, R. R.	Scot. to E.-in-C.O.	22.8.60
Jones, P. F.	E.-in-C.O.	31.8.60	Short, D. A.	E.-in-C.O.	22.8.60
Pikett, C. C.	Mid. Reg.	1.9.60	Mead, F. G.	L.T. Reg. to E.-in-C.O.	22.8.60
Wyse, E.	W.B.C. to N.W. Reg.	1.9.60	Weller, G. A.	H.C. Reg. to E.-in-C.O.	22.8.60
Broadbent, F.	N.E. Reg. to N.W. Reg.	19.9.60	Matthew, J.	Scot.	28.7.60
Eltringham, G. C.	E.-in-C.O.	23.9.60	Willitt, K. C.	W.B.C.	27.7.60
Robinson, E. L. A.	E.-in-C.O.	23.9.60	Rowlands, J.	W.B.C.	27.7.60
Bond, W. W. G.	E.-in-C.O.	23.9.60	Aitken, A.	N.W. Reg.	22.8.60
<i>Assistant Engineer (Open Competition)</i>			Titchett, B.	N.W. Reg.	24.8.60
Reed, M.	E.-in-C.O.	1.2.60	Saunders, M. C.	H.C. Reg.	5.7.60
Morse, A. G. D.	E.-in-C.O.	22.8.60	Topsfield, A. N.	H.C. Reg.	5.7.60
Coaker, E.	E.-in-C.O.	22.8.60	Vernon, A. D.	H.C. Reg.	20.7.60
Haigh, G. R.	E.-in-C.O.	26.8.60	Gooch, W. F.	H.C. Reg.	11.7.60
Hatchett, S. F.	E.-in-C.O.	22.8.60	Bowler, R. A.	L.T. Reg.	3.8.60
Ovenden, J. F.	E.-in-C.O.	22.8.60	Crebbin, T. A.	L.T. Reg.	3.8.60
Jones, W. G. T.	E.-in-C.O.	22.8.60	Fost, B. J.	E.T.E.	13.9.60
Dixon, A.	E.-in-C.O.	22.8.60	Fraser, I. F.	W.B.C.	12.9.60
<i>Assistant Engineer (Limited Competition)</i>			Watt, J. T.	Scot.	23.8.60
Vincent, C.	S.W. Reg.	4.7.60	McDowall, J.	Scot.	23.8.60
<i>Inspector to Assistant Engineer</i>			Robertson, W. S.	L.T. Reg.	25.8.60
Ellis, S. J.	W.B.C.	16.5.60	Garbutt, F. A. E.	L.T. Reg.	25.8.60
Smith, A. L.	Mid. Reg.	28.6.60	Little, J. E.	L.T. Reg.	25.8.60
Burnett, E. C.	S.W. Reg.	25.7.60	Virgo, V. G.	L.T. Reg.	25.8.60
Bailey, G. E.	N.W. Reg.	18.7.60	Borman, R. F.	L.T. Reg.	25.8.60
Kewley, C. L. R.	N.W. Reg.	22.7.60	Campbell, J. D.	L.T. Reg.	25.8.60
Noice, P. W. C.	N.W. Reg.	22.8.60	Whipp, R. A.	L.T. Reg.	25.8.60
Pemberton, S. H.	N.W. Reg.	31.8.60	Richards, A. H.	L.T. Reg.	25.8.60
			Barrow, G.	L.T. Reg.	25.8.60
			Clements, G. R.	L.T. Reg.	25.8.60
			Rogers, A. F.	L.T. Reg.	25.8.60
			King, D. G.	L.T. Reg.	25.8.60
			Armfield, D. G. D.	L.T. Reg.	25.8.60
			Cornick, R. F.	L.T. Reg.	25.8.60
			Stow, J. E.	L.T. Reg.	26.8.60
			Balls, S. C. N.	L.T. Reg.	25.8.60
			Phillips, R.	L.T. Reg.	25.8.60
			Gillard, S. E.	L.T. Reg.	26.8.60

Promotions—continued

Name	Region, etc.	Date	Name	Region, etc.	Date
<i>Technical Officer to Assistant Engineer—continued</i>			<i>Senior Scientific Officer (Open Competition)</i>		
Gibbs, J. T. ..	L.T. Reg. ..	25.8.60	Priscott, B. H. ..	E.-in-C.O. ..	1.9.60
Hogben, R. C. ..	L.T. Reg. ..	25.8.60	<i>Assistant Experimental Officer (Open Competition)</i>		
Hampton, A. E. ..	L.T. Reg. ..	12.9.60	Perry, R. ..	E.-in-C.O. ..	5.7.60
Perry, D. J. ..	L.T. Reg. ..	25.8.60	<i>Assistant (Scientific) (Open Competition)</i>		
Lock, W. E. W. ..	W.B.C. ..	31.8.60	Todd, R. (Miss) ..	E.-in-C.O. ..	8.8.60
Hocking, C. E. ..	W.B.C. ..	12.9.60	<i>Assistant Regional Motor Transport Officer to Motor Transport Officer II</i>		
Whittaker, A. ..	N.W. Reg. ..	7.9.60	Mitchell, A. J. ..	N.I. to E.-in-C.O. ..	19.7.60
Magness, G. R. ..	N.W. Reg. ..	30.9.60	<i>Technical Assistant I to Assistant Regional Motor Transport Officer</i>		
<i>Technical Officer to Inspector</i>			Bell, D. H. ..	E.-in-C.O. to N.E. Reg. ..	4.8.60
Palmer, H. ..	L.T. Reg. ..	12.9.60	<i>Technical Assistant I to Motor Transport Officer III</i>		
Goodman, L. J. ..	L.T. Reg. ..	12.9.60	Bignell, G. C. ..	E.-in-C.O. ..	11.7.60
West, A. G. L. ..	L.T. Reg. ..	25.8.60	Edwards, W. T. A. ..	E.-in-C.O. ..	15.9.60
<i>Technician I to Inspector</i>			<i>Leading Draughtsman to Senior Draughtsman</i>		
Grubb, G. ..	W.B.C. ..	9.6.60	Cooper, G. A. ..	E.-in-C.O. ..	7.6.60
Hoskins, F. ..	Mid. Reg. ..	4.7.60	Kitchingham, H. J. ..	L.P. Reg. to L.T. Reg. ..	1.6.60
Oliver, S. G. ..	N.I. ..	28.6.60	<i>Draughtsman to Leading Draughtsman</i>		
Hutchinson, R. ..	N.I. ..	4.7.60	Edwards, R. D. ..	L.P. Reg. ..	13.6.60
Jones, K. D. ..	S.W. Reg. ..	19.7.60	Gibson, B. A. ..	L.P. Reg. ..	13.6.60
Cleave, W. H. ..	S.W. Reg. ..	25.7.60	Horridge, J. W. ..	E.-in-C.O. ..	22.6.60
Langley, R. ..	N.E. Reg. ..	7.7.60	Key, A. L. ..	N.E. Reg. ..	12.9.60
Wasson, H. ..	N.I. ..	9.7.60	Roberts, W. I. ..	Mid. Reg. to W.B.C. ..	3.10.60
Bennett, R. ..	N.W. Reg. ..	12.7.60	Storey, T. G. ..	L.P. Reg. ..	2.9.60
Roberts, J. M. ..	N.W. Reg. ..	20.7.60	Medley, J. ..	N.E. Reg. ..	2.9.60
Smith, J. ..	Mid. Reg. ..	5.8.60	Warner, G. W. ..	N.W. Reg. ..	5.9.60
Pearson, L. R. ..	Mid. Reg. ..	5.8.60	Newton, B. J. ..	Mid. Reg. ..	2.9.60
Dean, C. ..	S.W. Reg. ..	15.8.60	Roberts, J. E. ..	W.B.C. to N.W. Reg. ..	3.10.60
O'Neill, T. ..	S.W. Reg. ..	2.8.60	Lyon, J. C. ..	Scot. ..	19.9.60
Bond, J. H. ..	Mid. Reg. ..	22.8.60	Simmons, J. W. A. ..	Scot. ..	19.9.60
Simpson, A. ..	N.W. Reg. ..	22.8.60	Rickard, S. P. W. ..	W.B.C. to Scot. ..	3.10.60
Woodhead, D. E. ..	N.W. Reg. ..	22.8.60	<i>Higher Executive Officer to Senior Executive Officer</i>		
Pemberton, A. ..	N.W. Reg. ..	24.8.60	Roope, D. M. (Miss) ..	E.-in-C.O. ..	25.7.60
Kershaw, F. ..	N.W. Reg. ..	30.8.60	Smith, J. ..	E.-in-C.O. ..	29.8.60
Chalk, G. ..	H.C. Reg. ..	1.7.60	Faulkner, N. L. ..	E.-in-C.O. ..	3.10.60
Nuttall, J. R. T. ..	H.C. Reg. ..	16.8.60	<i>Executive Officer to Higher Executive Officer</i>		
Brice, S. H. B. ..	L.T. Reg. ..	3.8.60	Holliday, J. H. ..	E.-in-C.O. ..	25.7.60
Rayner, D. A. ..	L.T. Reg. ..	3.8.60	<i>Clerical Officer to Executive Officer</i>		
Alexander, J. F. ..	H.C. Reg. ..	2.8.60	Percival, M. A. E. (Mrs.) ..	E.-in-C.O. ..	25.7.60
Haywood, L. W. T. ..	H.C. Reg. ..	5.9.60	<i>Retirements and Resignations</i>		
Moth, R. S. ..	H.C. Reg. ..	5.9.60	<i>Regional Engineer</i>		
Nuthall, J. S. ..	H.C. Reg. ..	26.9.60	Bevis, W. F. ..	H.C. Reg. ..	15.8.60
Bolton, G. ..	N.E. Reg. ..	12.9.60	<i>Senior Executive Engineer</i>		
Gowland, J. W. ..	N.E. Reg. ..	12.9.60	Clifford, F. G. ..	E.-in-C.O. ..	31.7.60
Cheeseman, W. J. ..	L.T. Reg. ..	2.9.60	(Resigned)		
Willis, B. G. ..	L.T. Reg. ..	25.8.60	<i>Executive Engineer</i>		
Eager, H. A. ..	N.E. Reg. ..	12.9.60	Bickerton, J. ..	N.W. Reg. ..	1.6.60
Lowe, C. H. ..	N.E. Reg. ..	12.9.60	Thorn, F. W. J. ..	W.B.C. ..	6.8.60
Coates, E. W. ..	N.E. Reg. ..	13.9.60	Wilson, J. C. (Resigned) ..	E.-in-C.O. ..	31.8.60
Welsh, J. ..	N.I. ..	14.9.60	Hooper, J. (Resigned) ..	E.-in-C.O. ..	31.8.60
Moore, R. ..	N.I. ..	21.9.60	Wylie, G. A. (Resigned) ..	F.-in-C.O. ..	31.8.60
Wood, J. S. ..	N.W. Reg. ..	22.9.60	<i>Assistant Engineer</i>		
			Crichton, R. D. ..	Scot. ..	1.6.60
			Pond, L. A. ..	E.T.E. ..	9.6.60

Name	Region, etc.	Date	Name	Region, etc.	Date
<i>Regional Engineer</i>			<i>Assistant Engineer—continued</i>		
Bevis, W. F. ..	H.C. Reg. ..	15.8.60	Williams, R. V. C. ..	W.B.C. ..	30.6.60
<i>Senior Executive Engineer</i>			Daniels, J. E. ..	Mid. Reg. ..	2.7.60
Clifford, F. G. ..	E.-in-C.O. ..	31.7.60	Simpson, H. ..	N.E. Reg. ..	3.7.60
(Resigned)			Hill, H. W. ..	L.T. Reg. ..	20.7.60
<i>Executive Engineer</i>			Franks, B. A. ..	E.-in-C.O. ..	22.7.60
Bickerton, J. ..	N.W. Reg. ..	1.6.60	Allred, T. ..	Mid. Reg. ..	31.7.60
Thorn, F. W. J. ..	W.B.C. ..	6.8.60	Baxter, M. S. J. ..	E.-in-C.O. ..	8.7.60
Wilson, J. C. (Resigned) ..	E.-in-C.O. ..	31.8.60	(Resigned)		
Hooper, J. (Resigned) ..	E.-in-C.O. ..	31.8.60	Davies, H. V. G. ..	S.W. Reg. ..	31.5.60
Wylie, G. A. (Resigned) ..	F.-in-C.O. ..	31.8.60	Carpenter, T. F. ..	L.T. Reg. ..	1.8.60
<i>Assistant Engineer</i>			Pook, E. G. ..	L.T. Reg. ..	6.8.60
Crichton, R. D. ..	Scot. ..	1.6.60	Brimms, S. ..	L.T. Reg. ..	9.8.60
Pond, L. A. ..	E.T.E. ..	9.6.60	Stone, J. A. ..	L.T. Reg. ..	10.8.60
			Hilton, H. ..	N.E. Reg. ..	13.8.60
			Bangay, R. ..	L.T. Reg. ..	24.8.60
			Topfield, A. W. ..	H.C. Reg. ..	31.8.60
			Bell, W. M. ..	N.E. Reg. ..	6.9.60

Retirements and Resignations--continued

Name	Region, etc.	Date	Name	Region, etc.	Date
<i>Assistant Engineer--continued</i>			<i>Scientific Officer</i>		
Cook, F. F. ..	W.B.C. ..	9.9.60	Meadows, R. G. ..	E.-in-C.O. ..	31.8.60
Myers, S. ..	N.W. Reg. ..	18.9.60	(Resigned)		
Shrimpton, W. H. ..	H.C. Reg. ..	20.9.60	Maynard, J. W. ..	E.-in-C.O. ..	30.9.60
Dennison, J. M. ..	N.E. Reg. ..	29.9.60	(Resigned)		
Boon, W. H. H. ..	N.E. Reg. ..	20.9.60	<i>Assistant Experimental Officer</i>		
Lipscombe, J. E. ..	E.-in-C.O. ..	30.9.60	Cooper, A. H. ..	E.-in-C.O. ..	2.9.60
Batty, J. S. (Resigned)	E.-in-C.O. ..	30.9.60	(Resigned)		
Joyce, L. A. (Resigned)	E.-in-C.O. ..	30.9.60	<i>Assistant (Scientific)</i>		
<i>Inspector</i>			Pratt, J. K. (Miss) ..	E.-in-C.O. ..	4.7.60
Maginnis, T. S. ..	N.I. ..	4.6.60	(Resigned)		
Mackenzie, T. G. ..	N.I. ..	8.7.60	Evans, A. L. (Resigned)	E.-in-C.O. ..	29.7.60
Moore, F. R. G. ..	S.W. Reg. ..	29.7.60	Downing, J. W. ..	E.-in-C.O. ..	13.9.60
Goater, W. J. ..	N.I. ..	13.8.60	(Resigned)		
Cornford, R. J. P. ..	H.C. Reg. ..	12.7.60	<i>Motor Transport Officer II</i>		
Lonnon, H. ..	H.C. Reg. ..	31.7.60	Bailey, C. S. ..	E.-in-C.O. ..	16.7.60
Pringle, J. R. ..	N.E. Reg. ..	7.8.60	<i>Technical Assistant II</i>		
Plowman, H. ..	N.E. Reg. ..	21.8.60	Waters, E. W. ..	London Reg. ..	30.9.60
Illman, K. H. ..	H.C. Reg. ..	23.8.60	<i>Senior Draughtsman</i>		
Horton, J. C. ..	L.T. Reg. ..	26.8.60	Furness, J. ..	Scot. ..	9.8.60
Amis, A. W. ..	L.T. Reg. ..	26.8.60	<i>Leading Draughtsman</i>		
Leonard, R. G. ..	L.T. Reg. ..	31.8.60	Wallis, C. A. ..	N.E. Reg. ..	10.8.60
Smith, F. C. ..	L.T. Reg. ..	1.9.60	Brewer, S. H. ..	Mid. Reg. ..	31.8.60
Dixon, J. ..	N.E. Reg. ..	10.9.60	<i>Senior Executive Officer</i>		
Melleny, L. G. ..	H.C. Reg. ..	11.9.60	Scrivener, W. H. ..	E.-in-C.O. ..	16.8.60
Longford, G. ..	N.E. Reg. ..	12.9.60	<i>Experimental Officer</i>		
Summers, R. G. ..	L.T. Reg. ..	18.9.60	Le Fevre, R. J. ..	E.-in-C.O. ..	30.9.60
Kilduff, W. ..	N.E. Reg. ..	24.9.60	(Resigned)		
Dodgen, S. W. ..	H.C. Reg. ..	30.9.60	<i>Transfers</i>		
Stockton, F. ..	W.B.C. ..	30.9.60			

Name	Region, etc.	Date	Name	Region, etc.	Date
<i>Area Engineer</i>			<i>Assistant Engineer</i>		
Smith, G. E. ..	L.T. Reg. to Ministry of Transport	29.8.60	Bennett, J. G. ..	E.-in-C.O. to Sarawak	5.4.57
<i>Senior Executive Engineer</i>			Hansford, D. J. ..	E.T.E. to Ministry of Aviation	1.6.60
Mitchell, G. ..	E.-in-C.O. to T.S.U. ..	12.9.60	Stubbs, D. F. ..	E.-in-C.O. to War Office	1.7.60
Balchin, D. B. ..	E.-in-C.O. to I.T.U., Geneva	26.9.60	Holman, R. V. ..	L.T. Reg. to Admiralty	18.7.60
<i>Executive Engineer</i>			Bedford, G. H. ..	E.-in-C.O. to W.B.C. ..	29.8.60
Jennings, S. W. ..	E.-in-C.O. to Ministry of Transport	15.8.60	Glassbrook, G. J. ..	L.T. Reg. to Ministry of Transport	8.8.60
Judd, D. L. ..	E.-in-C.O. to Ministry of Transport	29.8.60	<i>Assistant (Scientific)</i>		
Crowther, R. A. ..	Mid. Reg. to W.B.C. ..	1.8.60	Ward, R. P. ..	E.-in-C.O. to Ministry of Transport	1.9.60
McDowell, E. ..	L.T. Reg. to Ministry of Transport	8.8.60	<i>Assistant Regional Motor Transport Officer</i>		
Madder, J. D. C. ..	E.-in-C.O. to War Office ..	29.8.60	Byatt, H. A. ..	London Reg. to N.I. ..	19.7.60
Lang, W. N. ..	Approved Employment to E.-in-C.O.	1.9.60	<i>Motor Transport Officer III</i>		
Samuels, F. L. N. ..	E.-in-C.O. to Ministry of Power	12.9.60	Mundy, E. O. ..	E.-in-C.O. to London Reg.	18.7.60
			<i>Leading Draughtsman</i>		
			Watson, W. A. ..	L.T. Reg. to Mid. Reg. ..	5.9.60

Deaths

Name	Region, etc.	Date	Name	Region, etc.	Date
<i>Executive Engineer</i>			<i>Assistant Engineer--continued</i>		
Barron, H. ..	N.W. Reg. ..	18.9.60	Smurthwaite, J. ..	N.E. Reg. ..	15.9.60
<i>Assistant Engineer</i>			Mylam, J. H. ..	L.T. Reg. ..	29.9.60
Nuttall, G. H. ..	N.W. Reg. ..	13.7.60	<i>Inspector</i>		
Walton, F. ..	N.W. Reg. ..	16.7.60	Tanswell, H. E. ..	L.T. Reg. ..	11.7.60
Grafton, H. C. L. ..	Mid. Reg. ..	15.8.60	Pawlett, W. K. ..	Mid. Reg. ..	2.8.60
Orme, H. L. ..	N.W. Reg. ..	22.8.60	Alderson, W. ..	W.B.C. ..	11.9.60
Turner, H. E. ..	L.T. Reg. ..	25.8.60	Powning, S. H. ..	W.B.C. ..	12.9.60
Buchanan, D. R. ..	Scot. ..	28.8.60			

The Post Office Electrical Engineers' Journal

Volume 53, April 1960—January 1961

INDEX

A		PAGE NO.	C (continued)		PAGE NO.
ADAMS, H. C., and PRATTEN, L. W. Testing Facilities on Test-Desks in Automatic Telephone Exchanges ..		275	Closed-Circuit Colour Television ..		277
Administrative Radio Conference, Geneva, 17 August to 21 December, 1959, The ..		53	COBBE, D. W. R., and HORSFIELD, B. R. Effect of Railway Electrification on Post Office Circuits ..		184
AKESTER, K. M. A Switching Unit for Use with 700-Type Telephones—Plan Set N625 ..		242	COLLINGS, E. R., and THOMAS, A. W. Four New Engineering Vehicles ..		257
ALDERSON, J. H. The Letter-Carrying Chain Conveyor at Leeds Head Post Office ..		95	Colour Television, Closed-Circuit ..		277
ANDREWS, J. D., COPPING, G. P., and GERARD, P. S. Mechanization of the Initial Stages of Processing Mail (Part 2) ..		12	Computer Society's Second Annual National Conference, Harrogate, July 1960, The British ..		150
ANGELL, F. W., and HAYWARD, R. W. A New Cross-Connexion Assembly for Cabinets and Pillars ..		254	Computers. Sorting Techniques for Automatic ..		181
Anglo-Swedish Submarine Telephone Cable, The ..		165	Conference, Geneva, 17 August to 21 December, 1959, The Administrative Radio ..		53
Answering Set for Telephone Subscribers, An ..		45	Conference, Harrogate, July 1960, The British Computer Society's Second Annual National ..		150
ARCHER, E. C., and HUTTER, J. The Electronic Speech Voltmeter Type 5A ..		92	Conference on Electronic Telephone Exchanges, I.E.E. ..		235
Assembly for Cabinets and Pillars, A New Cross-Connexion Assessment of Transistor Life ..		254 236	Contacts for Use at Low Voltages, The Design and Testing of Semi-Permanent Metallic ..		26
Associate Section Notes ..	68, 140, 212,	285	Continuous-Reading Harmonic Analyser for Complex 50 c/s Waveforms, A ..		152
Automatic Control of the Rugby Radio (GBR) Time Signals by an Electronic Clock ..		193	Conveyor at Leeds Head Post Office, The Letter-Carrying Chain ..		95
Automatic Meter-Observation Equipment, An ..		124	COOPER, H. B., and LIGHT, R. A. M. Locating Faults Between Jointing Points on Pressurized Cables ..		89
B			COPPING, G. P., GERARD, P. S., and ANDREWS, J. D. Mechanization of the Initial Stages of Processing Mail (Part 2) ..		12
BARRON, D. A. (Appointment as Deputy Engineer-in-Chief) ..		60	Cordless P.A.B.X.s, An Introduction to Large ..		231
BARTLETT, G. A., PILLING, T., and STEPHENS, W. J. B. A Continuous-Reading Harmonic Analyser for Complex 50 c/s Waveforms ..		152	Cords, The Use of Modern Materials for Telephone ..		175
BELK, J. L. An Improved Trigger-Type Dial—the Dial, Automatic, No. 21 ..		40	COULMAN, A. H., and GOSS, C. E. G. Emergency Mobile Teleprinter Automatic Switching Units ..		268
BLAKEY, H., and GREEN, B. A. A Printing Recorder for Use with Observation Equipment ..		118	Cross-Connexion Assembly for Cabinets and Pillars, A New ..		254
BLANCHARD, C. H., NEWMAN, W. L., and WILLETT, W. H. The Switching of Television Circuits in London ..		102	CUMMINGS, F. G. The Drum-Type Machine for Cleaning Mail Bags ..		36
Booth, Capt. C. F. (Appointment as Deputy Engineer-in-Chief) ..		61	D		
BRIGGS, E., and PETERS, B. New Coast Radio Stations ..		170	Damage Due to Lightning and Contacts with Power Lines, Protection of Exchange Equipment and Subscribers' Installations from ..		219
British Computer Society's Second Annual National Conference, Harrogate, July 1960, The ..		150	Data Transmission, Delft, 1960, International Symposium on ..		260
BRONSDON, E. G. A Signal Generator for Testing Band 7 (H.F.) Radio Transmitters ..		160	Deaf Subscribers—Handset No. 4, A New Telephone for Design and Testing of Semi-Permanent Metallic Contacts for Use at Low Voltages, The ..		26
BROOK, H. D. Induction Hardening of Diagonal-Cutting Nippers ..		247	Dial, Automatic, No. 21, An Improved Trigger-Type Dial—The ..		40
C			Dialling over the Transatlantic Telephone Cables, Signalling Arrangements for ..		201
Cabinets and Pillars, A New Cross-Connexion Assembly for ..		254	Direct-Pick-Up Television Links, A Receiver for ..		239
Cable Construction in the Tropics, Plastic Telephone ..		162	Display and Recording Equipment for the Frequency Range 50 kc/s—8 Mc/s, An Insertion-Loss ..		145
Cable Projects, The SCOTICE/ICECAN Submarine ..		56	DONN, G. S., and REDMAN, F. W. G. An Automatic Meter-Observation Equipment ..		124
Cable System Direct to U.S.A.—TAT-3, A Proposed New Cable System, Proposed Commonwealth Pacific Telephone Cable, The Anglo-Swedish Submarine Telephone ..		167 42	Drum-Type Machine for Cleaning Mail Bags, The ..		36
Cables, A Moisture Barrier for Polythene-Sheathed ..		253	Ductile Permanent-Magnet Materials ..		262
Cables, Locating Faults Between Jointing Points on Pressurized ..		89	E		
Cables, Polythene-Sheathed Underground Telephone ..		250	EASTWOOD, G. W. Ductile Permanent-Magnet Materials ..		262
Calibration ..		192	Effect of Railway Electrification on Post Office Circuits ..		184
Calveley, C. E. (Appointment as Assistant Engineer-in-Chief) ..		61	Electronic Clock, Automatic Control of the Rugby Radio (GBR) Time Signals by an ..		193
Chain Conveyor at Leeds Head Post Office, The Letter-Carrying ..		95	Electronic Clock for Television Network Switching, An ..		108
Channel Equipment Design for Economy of Band-width ..		112	Electronic Speech Voltmeter Type 5A, The ..		92
CLARK, T. H., THOMSON, I. S., and PRICE, C. K. A Magnetic-Drum-Type Automatic Traffic Equipment with Transistor Switching Elements ..		50	Electronic Switching Equipment, Voltage-Margin Testing of Telegraph ..		173
CLINCH, C. E. E. Time Assignment Speech Interpolation (T.A.S.I.) ..		197	Electronic Telephone Exchanges, I.E.E. Conference on ..		235
Clock for Television Network Switching, An Electronic ..		108	ELKINS, N. A., MILLS, D. E., and FENSOME, L. D. W. A Receiver for Direct-Pick-Up Television Links ..		239
			ELLIS, D. R. B. Equipment for the Provision of Statistical Data Concerning Subscriber-Dialled Trunk Calls ..		127
			Emergency Mobile Teleprinter Automatic Switching Units ..		268

E (continued)	PAGE NO.	H (continued)	PAGE NO.
Engineering Vehicles, Four New	257	HOLT, J. B., and GARDINER, R. Closed-Circuit Colour Television	277
Equipment for the Provision of Statistical Data Concerning Subscriber-Dialled Trunk Calls	127	HOOKER, E. J., and GLOVER, D. W. A Moisture Barrier for Polythene-Sheathed Cables	253
Error-Correcting Systems for Use on Radio-Telegraph Circuits, A Monitor for 7-Unit Synchronous	1	HORSFIELD, B. R., and COBBE, D. W. R. Effect of Railway Electrification on Post Office Circuits	184
Exhibition of Subscribers' Apparatus and Associated Equipment at 2-12 Gresham Street, London, E.C.2	265	HUNT, C. S. Frequency-Modulated Voice-Frequency Telegraph Systems for Radio Telegraph Services	21
Extension of Ongar Radio Station	158	HUTTER, J., and ARCHER, E. C. The Electronic Speech Voltmeter Type 5A	92
F		I	
FAIRWEATHER, A., and FROST, E. J. The Design and Testing of Semi-Permanent Metallic Contacts for Use at Low Voltages	26	I.E.E. Conference on Electronic Telephone Exchanges	235
Faults Between Jointing Points on Pressurized Cables, Locating	89	ICECAN Submarine Cable Projects, The SCOTICE/	56
FEASEY, R. J., and YOUNG, E. J. Modifications to Aluminium-Alloy Ladders	80	Improved Trigger-Type Dial—the Dial, Automatic, No. 21, An	40
Felling of Latticed Steel Masts at Somerton Radio Station	274	Induction Hardening of Diagonal-Cutting Nippers	247
FENSOME, L. D. W., ELKINS, N. A., and MILLS, D. E. A Receiver for Direct-Pick-Up Television Links	239	Insertion-Loss Display and Recording Equipment for the Frequency Range 50 kc/s-8 Mc/s, An	145
FORD, A. E., and WHYTE, J. S. An Insertion-Loss Display and Recording Equipment for the Frequency Range 50 kc/s-8 Mc/s	145	Institution of Post Office Electrical Engineers 62, 132, 208,	282
Four New Engineering Vehicles	257	International Symposium on Data Transmission, Delft, 1960	260
4-Wire Extension Principle for Small Cordless P.M.B.X. Switchboards, The	167	Introduction to Large Cordless P.A.B.X.s, An	231
Frame, The Telephone Exchange Main Distribution	226	J	
Frequency-Modulated Voice-Frequency Telegraph Systems for Radio Telegraph Services	21	Jacks for Telephone Exchange Equipment, New Test	48
Frequency Range 50 kc/s-8 Mc/s, An Insertion-Loss Display and Recording Equipment for the	145	JOYCE, L. A., and LANDER, A. C. An Electronic Clock for Television Network Switching	108
FROME, Sir NORMAN. Plastic Telephone Cable Construc- tion in the Tropics	162	L	
FROOM, R. P., LEE, F. J., HILTON, C. G., and MACKRILL, P. A Monitor for 7-Unit Synchronous Error-Correcting Systems for Use on Radio-Telegraph Circuits	1	Ladders, Modifications to Aluminium-Alloy	80
FROST, E. J., and FAIRWEATHER, A. The Design and Testing of Semi-Permanent Metallic Contacts for Use at Low Voltages	26	LANDER, A. C., and JOYCE, L. A. An Electronic Clock for Television Network Switching	108
G		LAW, H. B., REYNOLDS, J., and SIMPSON, W. G. Channel Equipment Design for Economy of Band-width	112
GARDINER, R., and HOLT, J. B. Closed-Circuit Colour Television	277	LEE, F. J., FROOM, R. P., HILTON, C. G., and MACKRILL, P. A Monitor for 7-Unit Synchronous Error-Correcting Systems for Use on Radio-Telegraph Circuits	1
Generator for Testing Band 7 (H.F.) Radio Transmitters, A Signal	160	Leeds Head Post Office, The Letter-Carrying Chain Conveyor at	95
GERARD, P. S., COPPING, G. P., and ANDREWS, J. D. Mechanization of the Initial Stages of Processing Mail (Part 2)	12	Letter-Carrying Chain Conveyor at Leeds Head Post Office, The	95
GLOVER, D. W., and HOOKER, E. J. A Moisture Barrier for Polythene-Sheathed Cables	253	LIDBETTER, E. J. The 4-Wire Extension Principle for Small Cordless P.M.B.X. Switchboards	167
GOSS, C. E. G., and COULMAN, A. H. Emergency Mobile Teleprinter Automatic Switching Units	268	Lifting and Handling, Manual	82
GREEN, B. A., and BLAKEY, H. A Printing Recorder for Use with Observation Equipment	118	LIGHT, R. A. M., and COOPER, H. B. Locating Faults Between Jointing Points on Pressurized Cables	89
H		Light-weight Headset for Telephone Operators, A	177
Handling, Manual Lifting and	82	Lightning and Contacts with Power Lines, Protection of Exchange Equipment and Subscribers' Installations from Damage Due to	219
Handset No. 4, A New Telephone for Deaf Subscribers— Hardening of Diagonal-Cutting Nippers, Induction	24	Line-Signal Monitoring Unit Using Transistors, A	121
Harmonic Analyser for Complex 50 c/s Waveforms, A Continuous-Reading	152	LITTLE, S. J. Protection of Exchange Equipment and Subscribers' Installations Due to Lightning and Contacts with Power Lines	219
HARRIS, Brig. Sir L. H. (Retirement)	58	Locating Faults Between Jointing Points on Pressurized Cables	89
HARRISON, A. F. Voltage-Margin Testing of Telegraph Electronic Switching Equipment	173	LOWE, W. T. A New Telephone for Deaf Subscribers— Handset No. 4	24
HAYES, H. C. S. Polythene-Sheathed Underground Telephone Cables	250	M	
HAYWARD, R. W., and ANGELL, F. W. A New Cross- Connexion Assembly for Cabinets and Pillars	254	MCCLEMENTS, J. S. Automatic Control of the Rugby Radio (GBR) Time Signals by an Electronic Clock	193
Headset for Telephone Operators, A Light-weight	177	MACKRILL, P., FROOM, R. P., LEE, F. J., and HILTON, C. G. A Monitor for 7-Unit Synchronous Error-Correcting Systems for Use on Radio-Telegraph Circuits	1
HENDERSON, J. C. Assessment of Transistor Life	236	Magnet Materials, Ductile Permanent-	262
HILTON, C. G., FROOM, R. P., LEE, F. J., and MACKRILL, P. A Monitor for 7-Unit Synchronous Error- Correcting Systems for Use on Radio-Telegraph Circuits	1	Magnetic-Drum-Type Automatic Traffic Equipment with Transistor Switching Elements, A	50
HIX, K. W. The Telephone Exchange Main Distribution Frame	226	Mail Bags, The Drum-Type Machine for Cleaning	36
HOLDEN, R., and MEATYARD, L. R. Extension of Ongar Radio Station	158	Mail, Mechanization of the Initial Stages of Processing (Part 2)	12
HOLMES, M. F., and REYNOLDS, F. H. New Valves for Deep-Water Submerged Telephone-Repeaters	98	MANNING, D. J. The Post Office Type 1 Ratchet Relay	154
		Manual Lifting and Handling	82
		MARCHANT, P. A. An Introduction to Large Cordless P.A.B.X.s	231
		Mast for Radio Stations, A 150-Foot	271
		Masts at Somerton Radio Station, Felling of Latticed Steel	274
		Materials for Telephone Cords, The Use of Modern	175

	PAGE NO.
<i>M (continued)</i>	
MEATYARD, L. R., and HOLDEN, R. Extension of Ongar Radio Station	158
Mechanization of the Initial Stages of Processing Mail Part 2—Automatic Facing and Stamp Cancellation ..	12
Merriman, J. H. H. (Promotion to Staff Engineer) ..	206
Meter-Observation Equipment, An Automatic ..	124
Mew, G. M. (Promotion to Chief Regional Engineer) ..	281
MILLS, D. E., ELKINS, N. A., and FENSOME, L. D. W. A Receiver for Direct-Pick-Up Television Links ..	239
Modifications to Aluminium-Alloy Ladders ..	80
Moisture Barrier for Polythene-Sheathed Cables, A ..	253
Monitor for 7-Unit Synchronous Error-Correcting Systems for Use on Radio-Telegraph Circuits, A ..	1
Monitoring Unit Using Transistors, A Line-Signal ..	121
MOONEY, B. K. The Repair of Shallow-Water Submerged Repeaters	9
Mumford, A. H. (Appointment as Engineer-in-Chief) ..	59

N

New Coast Radio Stations	170
New Cross-Connexion Assembly for Cabinets and Pillars, A	254
New Switching and Transmission Plan for the Inland Trunk Network, A	75
New Telephone for Deaf Subscribers—Handset, No. 4, A ..	24
New Test Jack for Telephone Exchange Equipment ..	48
New Valves for Deep-Water Submerged Telephone-Repeaters	98
NEWMAN, W. L., BLANCHARD, C. H., and WILLET, W. H. The Switching of Television Circuits in London ..	102
Nippers, Induction Hardening of Diagonal-Cutting ..	247
Notes and Comments	60, 131, 206, 281

O

Observation Equipment, A Printing Recorder for Use with 150-Foot Mast for Radio Stations, A	118
Ongar Radio Station, Extension of	271
Ongar Radio Station, Extension of	158

P

P.A.B.X.s, An Introduction to Large Cordless	231
Pacific Telephone Cable System, Proposed Commonwealth ..	42
PENDLEBURY, N. H. A Pulsing and Ringing Machine for U.A.X.s	87
PETERS, B., and BRIGGS, E. New Coast Radio Stations ..	170
Pillars, A New Cross-Connexion Assembly for Cabinets and ..	254
PILLING, T., BARTLETT, G. A., and STEPHENS, W. J. B. A Continuous-Reading Harmonic Analyser for Complex 50 c/s Waveforms	152
Plan Set N625, A Switching Unit for Use with 700-Type Telephones—	242
Plastic Telephone Cable Construction in the Tropics ..	162
Polythene-Sheathed Cables, A Moisture Barrier for ..	253
Polythene-Sheathed Underground Telephone Cables ..	250
Post Office Type I Ratchet Relay, The	154
Power Lines, Protection of Exchange Equipment and Subscribers' Installations from Damage Due to Lightning and Contacts with	219
PRATTEN, L. W., and ADAMS, H. C. Testing Facilities on Test-Desks in Automatic Telephone Exchanges	275
PRICE, C. K. A Line-Signal Monitoring Unit Using Transistors	121
PRICE, C. K., CLARK, T. H., and THOMSON, I. S. A Magnetic-Drum-Type Automatic Traffic Equipment with Transistor Switching Elements	50
Printing Recorder for Use with Observation Equipment, A ..	118
Proposed Commonwealth Pacific Telephone Cable System ..	42
Proposed New Cable System Direct to U.S.A.—TAT-3, A ..	169
Protection of Exchange Equipment and Subscribers' Installations from Damage Due to Lightning and Contacts with Power Lines	219
Pulsing and Ringing Machine for U.A.X.s, A	87

R

Radio Conference, Geneva, 17 August to 21 December, 1959, The Administrative	53
Radio Investigation Work, A Vehicle for	34
Radio Stations, A 150-Foot Mast for	271

R (continued)

	PAGE NO.
Radio Stations, New Coast	170
Radio-Telegraph Circuits, A Monitor for 7-Unit Synchronous Error-Correcting Systems for Use on ..	1
Radio Telegraph Services, Frequency-Modulated Voice-Frequency Telegraph Systems for	21
Railway Electrification on Post Office Circuits, Effect of ..	184
RANDALL, F. L. An Answering Set for Telephone Subscribers	45
RATA, S. Manual Lifting and Handling	82
Ratchet Relay, The Post Office Type I	154
Receiver for Direct-Pick-Up Television Links, A	239
Recorder for Use with Observation Equipment, A Printing ..	118
Recording Equipment for the Frequency Range 50 kc/s—8Mc/s, An Insertion-Loss Display and	145
REDMAN, F. W. G., and DONN, G. S. An Automatic Meter-Observation Equipment	124
Regional Notes	64, 134, 209, 283
Relay, The Post Office Type I Ratchet	154
Repair of Shallow-Water Submerged Repeaters, The ..	9
Repeaters, New Valves for Deep-Water Submerged Telephone-	98
Repeaters, The Repair of Shallow-Water Submerged ..	9
REYNOLDS, F. H., and HOLMES, M. F. New Valves for Deep-Water Submerged Telephone-Repeaters	98
REYNOLDS, J., LAW, H. B., and SIMPSON, W. G. Channel Equipment Design for Economy of Band-width ..	112
Ringling Machine for U.A.X.s, A Pulsing and	87
ROBERTON, J. S. P., and SPENCER, H. J. C. A Light-weight Headset for Telephone Operators	177
Rugby Radio (GBR) Time Signals by an Electronic Clock, Automatic Control of the	193

S

Satellite, Signal Transmission Across the Atlantic via a Passive Earth	270
SCOTICE/ICECAN Submarine Cable Projects, The	56
700-Type Telephones—Plan Set N625, A Switching Unit for Use with	242
Signal Generator for Testing Band 7 (H.F.) Radio Transmitters, A	160
Signal Transmission Across the Atlantic via a Passive Earth Satellite	270
Signalling Arrangements for Dialling over the Transatlantic Telephone Cables	201
SIMPSON, W. G., LAW, H. B., and REYNOLDS, J. Channel Equipment Design for Economy of Band-width ..	112
SLATER, G. H. A Vehicle for Radio Investigation Work ..	34
Somerton Radio Station, Felling of Latticed Steel Masts at Sorting Techniques for Automatic Computers	181
Speech Voltmeter Type 5A, The Electronic	92
SPENCER, H. J. C. A Table Telephone with Four Push-Button Keys—Telephone No. 710	190
SPENCER, H. J. C., and ROBERTON, J. S. P. A Light-weight Headset for Telephone Operators	177
Staff Changes	72, 143, 216, 288
Stanesby, H. (Appointment as Deputy Director of Research)	206
Statistical Data Concerning Subscriber-Dialled Trunk Calls, Equipment for the Provision of	127
STEPHENS, W. J. B., PILLING, T., and BARTLETT, G. A. A Continuous-Reading Harmonic Analyser for Complex 50 c/s Waveforms	152
STRATTON, J., and TOBIN, W. J. E. A New Switching and Transmission Plan for the Inland Trunk Network ..	75
STRINGER, J. B. Sorting Techniques for Automatic Computers	181
Subscriber-Dialled Trunk Calls, Equipment for the Provision of Statistical Data Concerning	127
Subscribers' Apparatus and Associated Equipment at 2-12 Gresham Street, London, E.C.2, Exhibition of ..	265
Swedish Submarine Telephone Cable, The Anglo-Switchboards, The 4-Wire Extension Principle for Small Cordless P.M.B.X.	165
Switching and Transmission Plan for the Inland Trunk Network, A New	75
Switching of Television Circuits in London, The	102
Switching Unit for Use with 700-Type Telephones—Plan Set N625, A	242
Symposium on Data Transmission, Delft, 1960, International	260

T	PAGE NO.
(T.A.S.I.), Time Assignment Speech Interpolation ..	197
Table Telephone with Four Push-Button Keys—Telephone No. 710, A ..	190
TAT-3, A Proposed New Cable System Direct to U.S.A.—	167
Telegraph Systems for Radio Telegraph Services, Frequency-Modulated Voice-Frequency ..	21
Telephone Exchange Main Distribution Frame, The ..	226
Telephone No. 710, A Table Telephone with Four Push-Button Keys— ..	190
Telephone, Trial of a New Type of Wall ..	55
Teletypewriter Automatic Switching Units, Emergency Mobile ..	268
Television Circuits in London, The Switching of ..	102
Television, Closed-Circuit Colour ..	277
Television Links, A Receiver for Direct-Pick-Up ..	239
Television Network Switching, An Electronic Clock for ..	108
Test-Desks in Automatic Telephone Exchanges, Testing Facilities on ..	275
Test Jack for Telephone Exchange Equipment, New ..	48
Tester for Outlets from 2-Motion Selector Banks, A ..	196
Testing Band 7 (H.F.) Radio Transmitters, A Signal Generator for ..	160
Testing Facilities on Test-Desks in Automatic Telephone Exchanges ..	275
Testing of Semi-Permanent Metallic Contacts for Use at Low Voltages, The Design and ..	26
Testing of Telegraph Electronic Switching Equipment, Voltage-Margin ..	173
THOMAS, A. W., and COLLINGS, E. R. Four New Engineering Vehicles ..	257
THOMSON, I. S., CLARK, T. H., and PRICE, C. K. A Magnetic-Drum-Type Automatic Traffic Equipment with Transistor Switching Elements ..	50
Time Assignment Speech Interpolation (T.A.S.I.) ..	197
Time Signals by an Electronic Clock, Automatic Control of the Rugby Radio (GBR) ..	193
TOBIN, W. J. E., and STRATTON, J. A New Switching and Transmission Plan for the Inland Trunk Network ..	75
Traffic Equipment with Transistor Switching Elements, A Magnetic-Drum-Type Automatic ..	50

T (continued)	PAGE NO.
Transatlantic Telephone Cables, Signalling Arrangements for Dialling over the ..	201
Transistor Life, Assessment of ..	236
Transistor Switching Elements, A Magnetic-Drum-Type Automatic Traffic Equipment with ..	50
Transmission Across the Atlantic via a Passive Earth Satellite, Signal ..	270
Transmission Plan for the Inland Trunk Network, A New Switching and ..	75
Trial of a New Type of Wall Telephone ..	55
Trigger-Type Dial—the Dial, Automatic, No. 21, An Improved ..	40
Trunk Network, A New Switching and Transmission Plan for the Inland ..	75
U	
Use of Modern Materials for Telephone Cords, The ..	175
V	
Valves for Deep-Water Submerged Telephone-Repeaters, New ..	98
Vehicle for Radio Investigation Work, A ..	34
Vehicles, Four New Engineering ..	257
Voltage-Margin Testing of Telegraph Electronic Switching Equipment ..	173
W	
Wall Telephone, Trial of a New Type of ..	55
WELCH, S. Signalling Arrangements for Dialling over the Transatlantic Telephone Cables ..	201
Wheatstone Bridge Circuit for Test-Desks ..	205
WHYTE, J. S., and FORD, A. E. An Insertion-Loss Display and Recording Equipment for the Frequency Range 50 kc/s–8 Mc/s ..	145
WILLETT, W. H., BLANCHARD, C. H., and NEWMAN, W. L. The Switching of Television Circuits in London ..	102
Y	
YOUNG, E. J., and FEASEY, R. J. Modifications to Aluminium-Alloy Ladders ..	80
YOUNG, S. G. A 150-Foot Mast for Radio Stations ..	271

BOARD OF EDITORS

D. A. HARRON, M.Sc., M.I.E.E., Chairman.
 L. F. SCANTLEBURY, Whit.Sch., A.C.G.I., D.I.C., M.I.E.E.
 T. H. FLOWERS, M.B.E., B.Sc.(Eng.), M.I.E.E.
 W. J. E. TOBIN, B.Sc.(Eng.), A.C.G.I., D.I.C., M.I.E.E.
 A. J. LECKENBY, M.B.E.
 G. J. MILLEN, A.M.I.E.E.
 R. F. WALDEGRAVE.
 E. DAVIS, A.M.I.E.E., Managing Editor.
 A. G. LEIGHTON, B.Sc.(Eng.), A.M.I.E.E., Deputy Managing Editor.
 J. MARTIN, B.Sc.(Eng.), A.M.I.E.E. } Assistant Editors.
 R. A. SUDDELL
 B. FARR, A.B.I., Secretary-Treasurer.
 B. CROSS, Advertisement Manager.

Copyright

The entire contents of this Journal are covered by general copyright, and special permission is necessary for reprinting long extracts, but editors are welcome to use not more than one-third of any article, provided credit is given at the beginning or end thus: "From *The Post Office Electrical Engineers' Journal*."

The Board of Editors is not responsible for the statements made or the opinions expressed in any of the articles in this Journal, unless such statement is made specifically by the Board.

Subscriptions and Back Numbers

The Journal is published quarterly, in April, July, October and January, price 2s. 6d. (3s. 6d. post paid) per copy or 14s. per year post paid (2 dollars 25 cents, Canada and U.S.A.). Back numbers will be supplied, if available, price 2s. 6d. (3s. 6d. post paid) per copy. Orders should be sent to *The Post Office Electrical Engineers' Journal*, G.P.O., 2-12 Gresham Street, London, E.C.2.

Employees of the British Post Office can obtain the Journal through local agents.

Binding Cases

Readers can have their copies of volumes bound at a cost of 10s. 6d. by sending the complete set of parts to the local Post Office distribution agent or to *The Post Office Electrical Engineers' Journal*, G.P.O., 2-12 Gresham Street, London, E.C.2. Alternatively, binding cases are available, price 3s., for those readers who wish to make their own arrangements for binding.

Remittances

Remittances should be made payable to "*The P.O.E.E. Journal*" and should be crossed "& Co."

Advertisements

All correspondence relating to advertisement space reservations, copy, proofs, etc., should be addressed to the Advertisement Manager, *The Post Office Electrical Engineers' Journal*, G.P.O., 2-12 Gresham Street, London, E.C.2.

Communications

With the exceptions indicated above, all communications should be addressed to the Managing Editor, *The Post Office Electrical Engineers' Journal*, G.P.O., 2-12 Gresham Street, London, E.C.2. Telephone: HEADquarters 1234.

Model Answer Books

Books of model answers to certain of the City and Guilds of London Institute examinations in telecommunications are published by the Board of Editors. Details of the books available are given at the end of the Supplement to the Journal.

More for less...

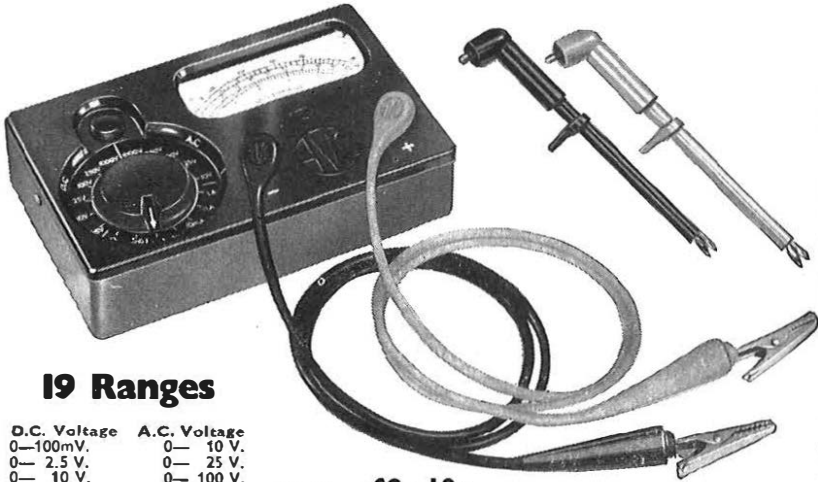

19 Ranges

D.C. Voltage	A.C. Voltage
0—100mV.	0— 10 V.
0— 2.5 V.	0— 25 V.
0— 10 V.	0— 100 V.
0— 25 V.	0— 250 V.
0— 100 V.	0—1000 V.
0— 250 V.	
0—1000 V.	
Resistance	D.C. Current
0—20,000Ω	0—100μA
0—2MΩ	0— 1mA
	0—10mA
	0—100mA
	0— 1 A

List Price: **£9 : 10s.**

complete with test Leads and Crocodile Clips.
Leather case if required 39/-

Size 5½ × 3½ × 1½ in.
Weight: 1 lb. approx.

DESIGNED to offer the widest possible range of accurate and reliable measurements at the lowest possible price, the versatility and usefulness of the Multiminor are now further extended by specially designed leads. These new leads, available at no extra cost, will accept crocodile clips or PRODCLIPS.

The Multiminor takes full advantage of the possibilities of printed circuit techniques to achieve outstanding compactness and economy of weight. The scale is clear and open. The fine red coloured pointer and effectively damped movement facilitate easy and rapid reading.

For use in Radio, TV, Electronics, Motor Vehicles, domestic appliances, workshop equipment, you'll find the Multiminor a great little meter!

Use PRODCLIPS with the Multiminor (Pat. No. 748811)

These cleverly designed spring-loaded insulated prods are the complete answer to a long-standing problem. Press the trigger to open, release to grip. Keep your hands free no matter how difficult of access your test points may be! 15/- per pair

...with the

MULTIMINOR

Write now for illustrated literature to:

AVO LTD AVOCET HOUSE
LONDON S.W.1

92-96 VAUXHALL BRIDGE ROAD
VICtoria 3404 (12 lines)

A MEMBER OF THE METAL INDUSTRIES GROUP OF COMPANIES



Radio Sonde and electronic equipment

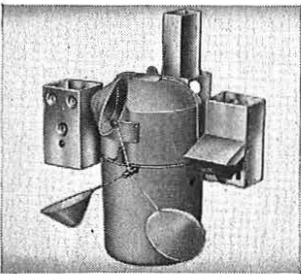

Radio Sonde Transmitter, supplied to British meteorological Office and foreign governments.

The items shown here are representative of the extensive variety of products manufactured by the Whiteley organisation. Our technical resources are available for the development and production of specialised components for the electronic industry.

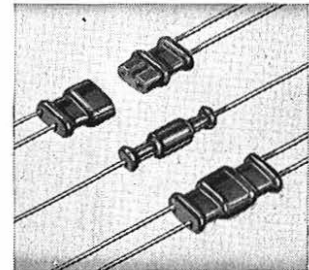

Waterproof plugs and sockets moulded in Polythene for under-water or outdoor installation.



Stentorian Cambric Cone Units, recognised throughout the world as the greatest value in High Fidelity.



The Post Office Tester is a multi-range meter used for making tests on subscribers' apparatus and lines.

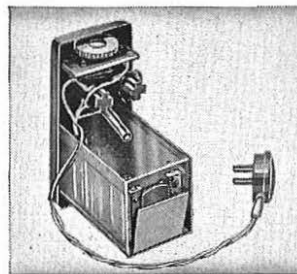

Potted components and assemblies in epoxy, Polyester resins and Polythene.



This fixed frequency oscillator is constructed on a standard octal base and encapsulated in epoxy resin.

WHITELEY ELECTRICAL RADIO CO. LTD · Mansfield · Notts

Ernest Turner

Electrical Measuring Instruments

Ideally matching contemporary panel design, the Ernest Turner Model 703, illustrated here, is enhanced by the flush-fitting surround. A high degree of accuracy is adequately supported by the easy-to-read scale and clean dial layout. Full details of the range of rectangular electrical measuring instruments and flush mountings are contained in Leaflets 85/G and 85/AF, available on request.

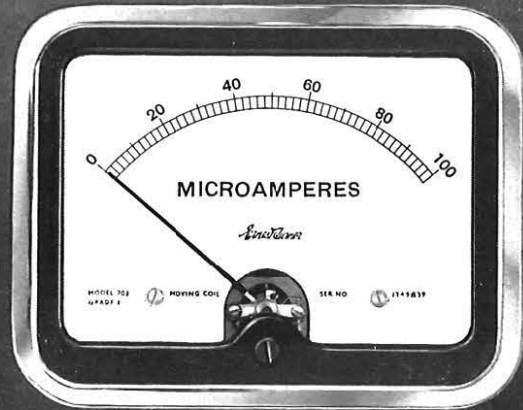

Ernest Turner Electrical Instruments Ltd
HIGH WYCOMBE · BUCKINGHAMSHIRE · ENGLAND

ATOMIC PLANT OR LINE TAP

corrosion prevention by the correct

DENSO

method is complete and enduring

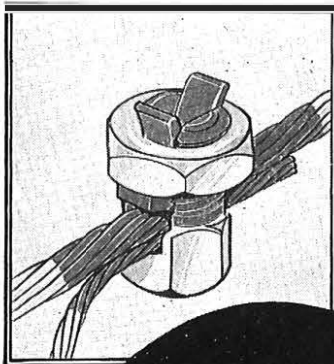

Electrical Engineers the world over use Denso Tapes, Cords and Mastics for: protection of machined surfaces in store or transit; temporary cable repairs; anti-galvanic insertion; anti-fusion lubrication; waterproofing, sealing, plugging, etc., etc.

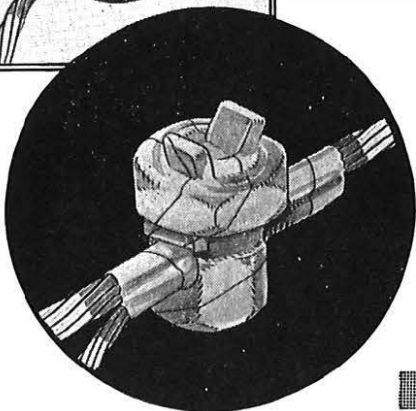

Copper-aluminium line tap coated with Denso Paste, wrapped in Denso Tape.



By courtesy of Geartight Unions Limited, manufacturers of the control rod standpipe closure assemblies for the Hunterston Generating Station being constructed by The General Electric Company Ltd. for the South of Scotland Electricity Board.



WINN & COALES LTD.
DENSO HOUSE, CHAPEL ROAD, LONDON, S.E.27

Telephone: GIPsy Hill 7511

Telegrams: Denselte, Westnor, London

Northern Area Headquarters: Denso House, Giebelands Road, Sale, Cheshire

Telephone: Sale 8271

Telegrams: Denselte, Sale, Cheshire

Agents throughout the Commonwealth



MARCONI

microwave
communication
systems

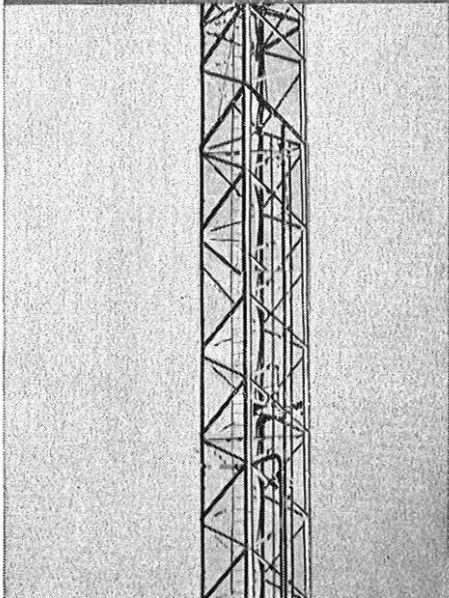
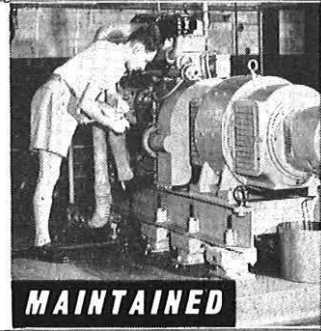
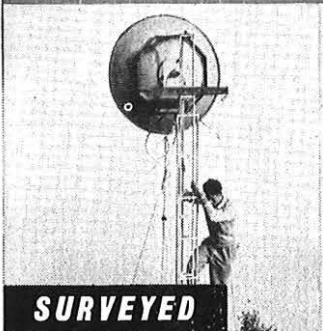

HIGH PERFORMANCE Marconi microwave systems, with capacities from 60 to 960 channels and capable of carrying high quality television, are designed to meet exacting international standards of performance with margins in hand.

EXTREME SIMPLICITY Travelling wave tube techniques ensure extremely simple circuitry and make full use of high gain and great band width available. A unidirectional repeater consists of only three travelling wave tube amplifiers and one frequency change oscillator with their power supplies.

GREAT RELIABILITY The use of travelling wave tubes in the repeaters has allowed considerable reduction in the number of valves and components used. Thus the likelihood of unexpected failure has been considerably reduced.

EASY MAINTENANCE The design of the units ensures easy access to all parts of the equipment and the extensive use of printed circuitry allows speedy and accurate replacement of precision circuits by technician staff, without realignment of the equipment.

EXTREME SAFETY All high voltages are fully interlocked.

World leaders in all travelling wave tube microwave systems

The Post and Telegraph Authorities in more than 80 countries rely on

MARCONI

COMMUNICATIONS SYSTEMS

MARCONI'S WIRELESS TELEGRAPH COMPANY LIMITED · CHELMSFORD · ESSEX · ENGLAND

HIF



VIDEO TRANSMISSION TEST EQUIPMENT

Designed by the British Post Office and engineered by Pye Telecommunications, these precision instruments provide both a signal source and performance indicator in accordance with C.C.I.R. testing standards. They may be used for testing the performance of broad band microwave link systems, coaxial cable systems and studio equipment.

Pulse and Bar Generator, PTC 1201/3. This generator produces a composite test signal consisting of a sine squared pulse and smoothed half line bar with line synchronising pulses, and is used for testing the transmission quality of video circuits. Models are available for use with either 405 or 625 line systems.

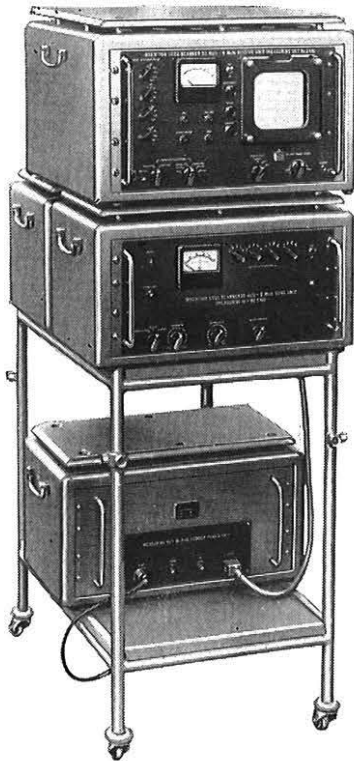
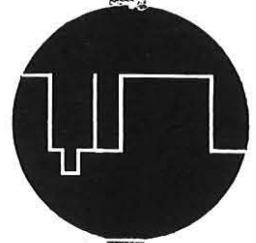
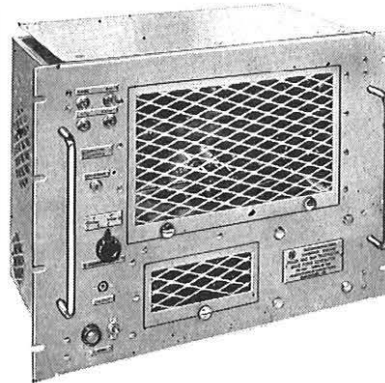

Video Transmission Oscilloscope, PTC 1205. This is a precision oscilloscope designed to work in conjunction with the PTC 1201/3 Pulse and Bar Generator and is suitable for use on 405, 525, or 625 line systems. Special features include calibration of amplitude and frequency, calibrated delay scan, hum filter, 10 kc/s square wave oscillator and timing wave generator frequencies of 1, 6, and 10 Mc/s.

Insertion Loss Scanner, PTC 1206. This equipment measures the insertion loss/frequency response in the range of 50 kc/s to 8 Mc/s. Both cathode ray tube presentation and pen-recording of the response characteristics are provided. It can be employed to make local or loop tests when the Send and Receive units are at any one location, and unidirectional tests when they are separated by a considerable distance.

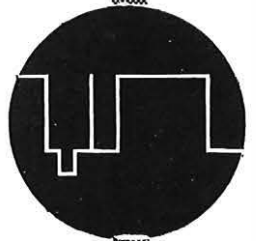
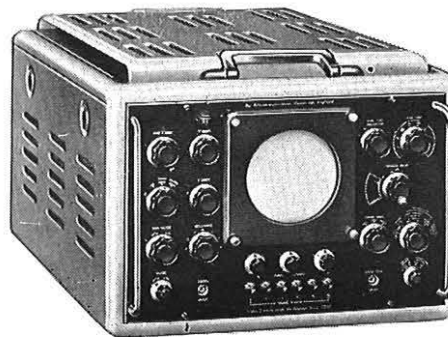
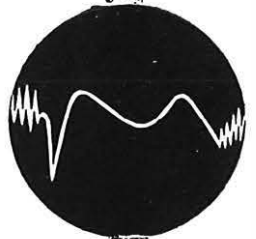

Please write for further details
PYE TELECOMMUNICATIONS LTD. NEWMARKET RD., CAMBRIDGE
Tel: Teversham 3131

HOW TO PASS YOUR CITY AND GUILDS TELECOMMUNICATIONS EXAMS—BY POST

The new Bennett College Telecommunications Courses were prepared under the supervision of one of the country's top telecommunications men, W. S. Procter, O.B.E., M.I.E.E., F.R.S.E., Chief Regional Engineer, London Telecommunications Region.

The first and second year subjects are:

FIRST YEAR 1. Practical Mathematics. 2. Engineering Science. 3. Engineering Drawing. 4. Elementary Telecommunications Practice.
SECOND YEAR 1. Mathematics for the Telecommunications A. 2. Telecommunications Principles A. 3. Radio and Line Transmission A. 4. Telephony and Telegraphy A. 5. Line Plant Practice A.

Other subjects will be introduced later.

The certificates awarded by the City and Guilds Institute are of special value to employees of the Post Office Telecommunications Branches, and the Radio and Telecommunications industry, whether engaged in the manufacture or the maintenance and operation of Telecommunications apparatus.

Post this coupon off at once for more information

TO: THE BENNETT COLLEGE (DEPT. 24WSPA) Sheffield
Please send me details of the new Telecommunications Courses

NAME

ADDRESS

AGE

Personal postal tuition through the famous Bennett College!

ELECTRONIC EQUIPMENT RELIABILITY

By G. W. A. Dummer, M.B.E., M.I.E.E., Sen. Mem. I.R.E., and N. Griffin, A.M.Brit.I.R.E.

For all concerned with the design of electronic components and equipment. The work covers the various factors affecting the life and behaviour of different components and circuits, e.g. humidity, temperature, pressure, etc. 45/- net

GUIDE TO THE SPACE AGE

By C. W. Besserer and Hazel C. Besserer

"Guide to the Space Age" is a comprehensive presentation of the terminology of space technology in dictionary form. Terms are authoritatively defined covering as broad an area as possible and many cross-references, drawings and diagrams are included. First published in America this book will provide a valuable insight into the technical background necessary to understand and evaluate the scientific developments in this new and exciting field. 47/6d. net.

From all booksellers

PITMAN Parker St.,
Kingsway, London, W.C.2

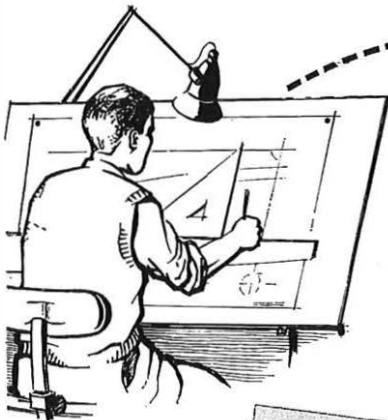

Economy begins at the design stage



Free technical literature



permanent magnets

Permanent magnets, like many other aspects of technology, are making spectacular progress day by day. Remarkable economies in production can be effected if experts are consulted at the design stage. Eclipse have a highly developed research programme that makes them leaders in this field. Bring Eclipse Permanent Magnets into your preliminary design discussions—and be thankful.

Made by the designers and manufacturers of Eclipse Permanent Magnet Chucks

JAMES NEILL & CO. (SHEFFIELD) LTD · SHEFFIELD · ENGLAND



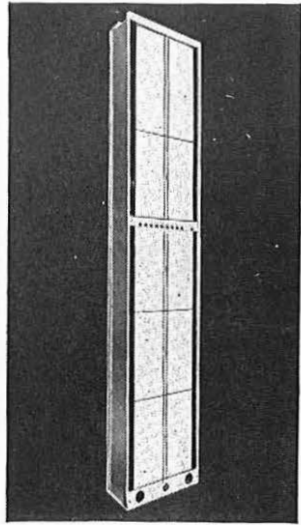

Terminal Rackside

C12G Cable Carrier System

- Fully Transistorised.
- 12 Channels on a single cable pair. (6-54 Kc/s and 60-108 Kc/s 'go' and 'return').
- Automatic pilot regulation, suitable for aerial or buried cables.
- Straight or 'frogging' repeaters.
- Terminal for 2 complete systems with signalling and frequency generating equipment on one 9 ft. rackside.

For details see Bulletin TEB 3201

Cable carrier systems by A.T.E.

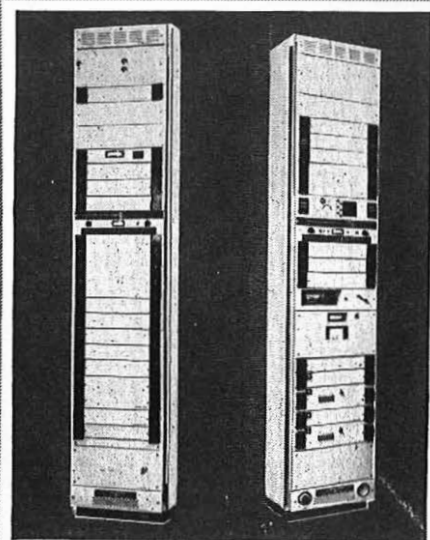

*Left: Terminal Repeater (Receive)
Right: Terminal Repeater (Transmit)*

C960A 4 Mc/s Coaxial System

- Up to 960 high-grade telephone circuits on each pair of conventional coaxial tubes.
- Power fed dependent repeaters at 6 mile spacing.
- Main power feed stations up to 100 miles apart.
- Comprehensive maintenance and test facilities.
- Conforms to C.C.I.T.T. recommendations.

For details see Bulletin TEB 1411

C300A Small Core Coaxial System

- Fully Transistorised.
- 300 channel system for small core coaxial cables.
- Intermediate power fed repeaters in sealed buried boxes.
- Automatic pilot regulation, suitable for buried or aerial cable.
- Power feeding stations may be up to 60 miles apart.
- Inbuilt maintenance and fault location facilities.

For details see Bulletin TEB 3202

Right: Terminal Repeater
Left: Intermediate Buried Repeater

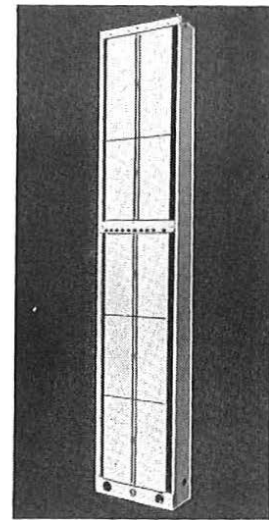
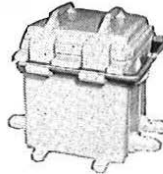

The A.T.E Range of Cable Carrier Systems features equipment for large and small capacity routes. All systems meet the internationally recognised C.C.I.T.T. requirements for trunk circuits, are of high quality and advanced design. Write for further details to:—

AUTOMATIC TELEPHONE & ELECTRIC CO LTD

Strowger House, Arundel Street, London, W.C.2. Phone: TEMple Bar 9262



A.T.E. TRANSMISSION EQUIPMENT TYPE CM FOR LINE, CABLE AND RADIO SYSTEMS.

CX12A 12.5 Mc/s Coaxial System

- Up to 2,700 high grade telephone circuits or transmission of mixed traffic on a pair of conventional .375 inch dia. coaxial tubes.
- Conforms to C.C.I.T.T. recommendations and G.P.O. specifications.
- Dependent repeaters power fed from terminal equipment, with automatic transfer to local mains supply in case of failure.
- Comprehensive maintenance and test facilities.

For details see Bulletin TEB 1417

Left: Dependent Repeater—5 ft.
Right: Terminal Repeater—9 ft.

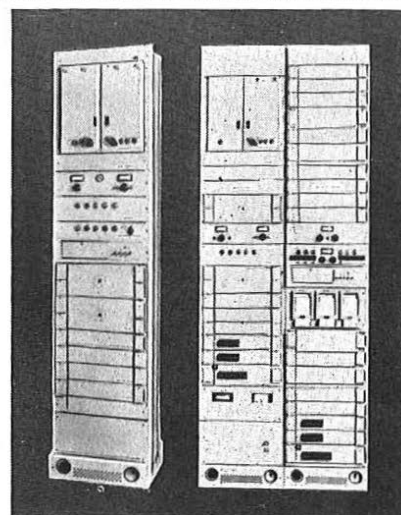

ADCOLA
PATENTED DESIGN
(Regd. Trade Mark)

FOR
SOLDERING INSTRUMENTS
and EQUIPMENT
 SUPPLIED FOR ALL VOLTAGES



illustrated

**DETACHABLE
 BIT**
MODEL $\frac{3}{8}$ "
 List 64

**PROTECTIVE
 SHIELD**
 List 68

..... Write for Catalogues
 HEAD OFFICE, SERVICE AND SALES
ADCOLA PRODUCTS LTD.
 GAUDEN ROAD, CLAPHAM HIGH STREET, LONDON, S.W.4
 Phone: MACaulay 3101, 4272

VALUABLE FREE BOOK

**Tells You How to Pass Your C. & G. or
 Promotion Exam. at First Attempt!**

All Post Office personnel who are anxious to obtain early promotion should at once send for a copy of our handbook "ENGINEERING OPPORTUNITIES" which, among other intensely interesting matter, describes our unique methods of preparation for the G.P.O. LIMITED COMPETITIONS for appointment as Assistant Engineer, Executive Engineer, Traffic Officer, Telecommunications Traffic Superintendent; CITY AND GUILDS EXAMINATIONS for the Telecommunication Technicians' Certificate and for individual subjects—Mathematics, Engineering Science, Engineering Drawing, Elementary Telecommunication Practice, Telecommunication Principles, Radio and Line Transmission, Telegraphy and Telephony, Line Plant Practice. It also contains details of our courses covering the City and Guilds Examinations in Electrical Engineering Practice, the Grad. Brit.I.R.E. and A.M.S.E. Examinations, in addition to a wide range of non-examination courses in all branches of engineering—Radio and Electronics, Electrical, Mechanical, etc.

We also provide tuition for the Radio Amateurs' Examination and the P.M.G. Certificates for Radio Operators, with or without Morse training. Details are given in the handbook.

**We definitely guarantee
 "NO PASS—NO FEE"**

If you intend to make the most of today's opportunities, you cannot afford to miss reading "ENGINEERING OPPORTUNITIES." It tells you everything you want to know to secure advancement, and describes many opportunities you may now be missing through lack of information. Send for your copy today—FREE and without obligation.

**BRITISH INSTITUTE
 OF ENGINEERING TECHNOLOGY**
 369 COLLEGE HOUSE,
 29-31 WRIGHT'S LANE, LONDON, W.8

BIET

**for the right
 connection**

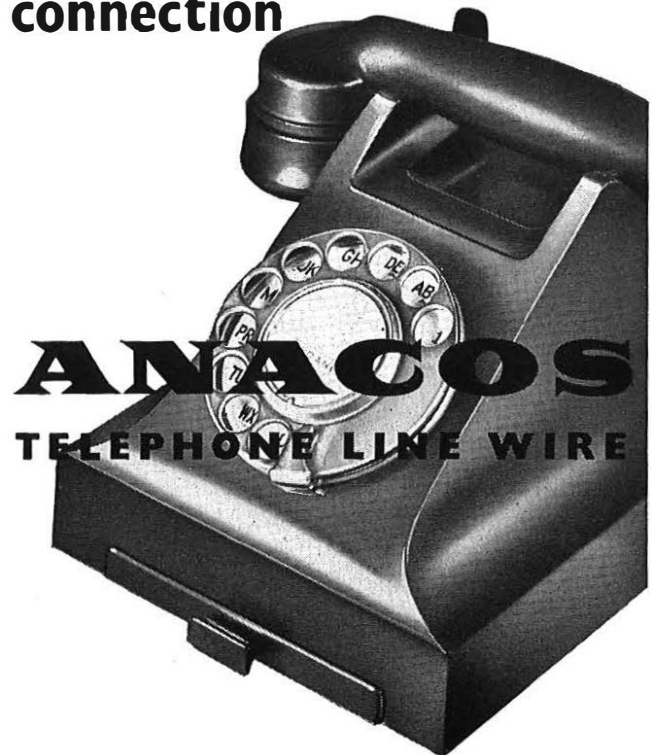

FREDERICK SMITH AND COMPANY
 ANACONDA WORKS · SALFORD 3 · LANCs



“Twwitterton!

Is this really

FORMICA*?”

Yes, this is a printed circuit made from a FORMICA copper-clad laminate. It is used in the newest type of telephone, beautifully made by The Plessey Company Limited to G.P.O. specifications. And it's just one of many Formica products.

Not so long ago, the name Formica was associated with decorative laminates, used mainly in kitchens and canteens. Today, among many other activities, Formica Ltd. with their industrial laminates make a valuable contribution to quick and reliable telecommunications. And in today's world you'll frequently come across most of the other Formica products listed below.

FORMICA
make

CHAIR SETS
DECORATIVE LAMINATES
INDUSTRIAL LAMINATES
EXTRUDED PLASTICS



For full information on any FORMICA product, please write to:

FORMICA LIMITED, De La Rue House, 84-86 Regent Street, London, W.1 Tel: REGent 8020

** FORMICA is a registered trade mark.*

HIGH SPEED AUTOMATIC MORSE EQUIPMENT



**Keyboard Perforator
Model 50**

Provided with locking device which prevents the simultaneous depression of two keys. Max. operating speed 750 characters per minute.

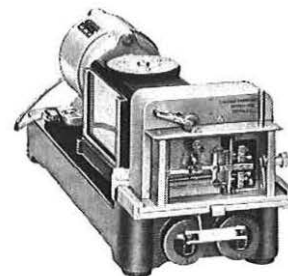

Transmitter Model 112

Speed range 13-250 words per minute. For training schools model 113 having a speed range of 5-35 words per minute is recommended.

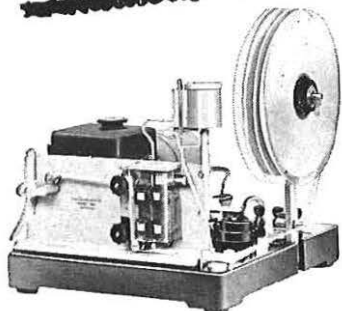

Undulator Model 309

Max. operating speed 300 words per minute. Other models available with double recording part and with amplifier/rectifier for tone frequency signals.



Reperforator Model 451

A truly synchronous receiver which produces a perforated tape similar to the one used for transmission. Normal speed range 40-200 words per minute.

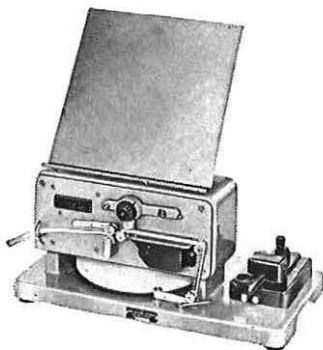
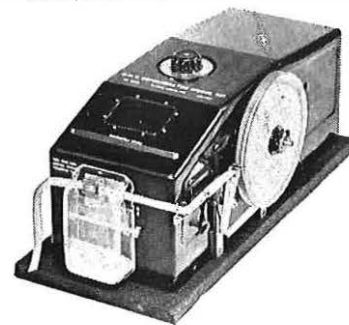

Morseinker Model 1515

Used for training purposes, Motor-driven. Also available with built-in amplifier/rectifier for tone frequency signals. Spring-driven models also available.

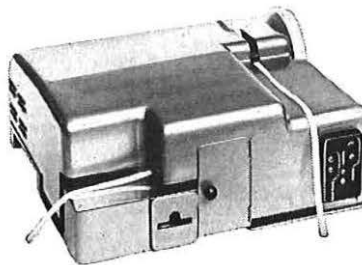

Converter Model 2201

For the conversion of a perforated Morse Code, or Cable Code, tape into a perforated 5-unit Code tape or into 5-unit signals at standard teleprinter speed.

Converter Model 2206

For the conversion of a perforated 5-unit Code tape into a perforated Morse Code, or Cable Code, tape.



GREAT NORTHERN TELEGRAPH WORKS

DIVISION OF THE GREAT NORTHERN TELEGRAPH CO. LTD.

4, SYDHAVNS PLADS
COPENHAGEN SV, DENMARK

LONDON OFFICE: 5, ST. HELEN'S PLACE
LONDON E. C. 3.

Glazed Vitrified Clay Conduits

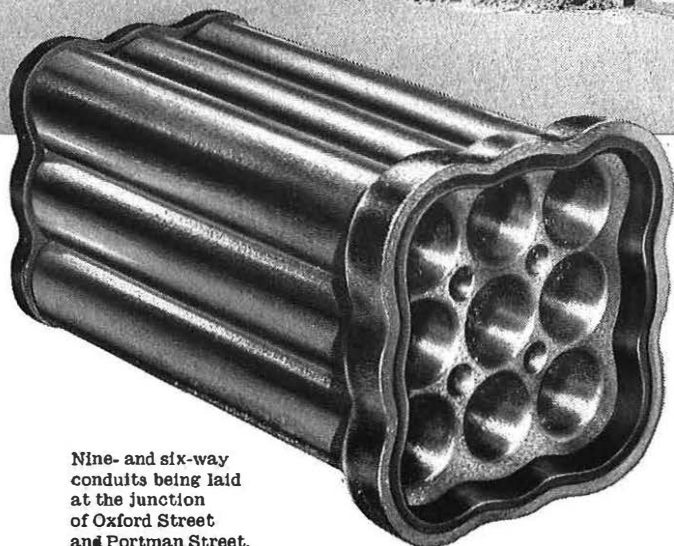

Nine- and six-way conduits being laid at the junction of Oxford Street and Portman Street, London W.1.

serve . . .
the West End well

Only **glazed vitrified clay conduits** can guarantee the degree of protection demanded by the authorities for the permanent security of our tele-communications. The importance of using **glazed vitrified clay conduits** is widely accepted to-day, especially in our cities where the flow of traffic must be disturbed to the minimum and where the heavy cost of re-excavation must be avoided.

Experience has proved that there is no adequate substitute for **glazed vitrified clay conduits**.

For information write to The Secretary

NATIONAL SALT GLAZED PIPE MANUFACTURERS' ASSOCIATION
Hanover Court, Hanover Square, LONDON, W.1.
Telephone MAYfair 0364.



These cables speak volumes for

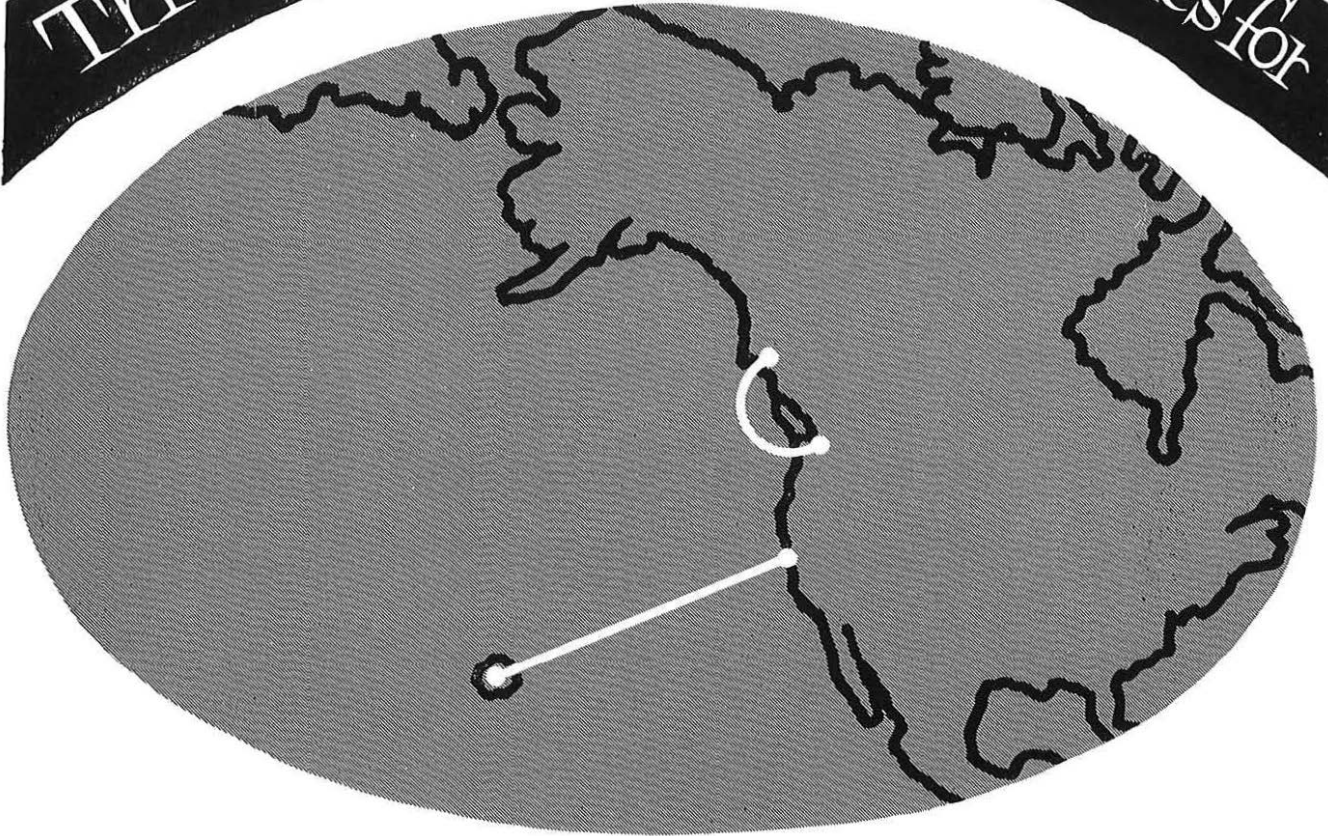

Fathoms below the Atlantic and the Pacific, mighty cables carry myriads of voices from wind-swept shores to palm fringed islands . . . from ice-bound ports to sun-scorched cities. Unseen, but playing a vitally important part is TMC CARRIER TELEPHONE EQUIPMENT, helping to narrow the distance between continents that were once, communicationally speaking, far apart. Full information about TMC 2 kc/s, 3 kc/s and 4 kc/s Spaced Carrier Telephone Equipment can be obtained simply by writing to the address below.



TELEPHONE MANUFACTURING COMPANY LIMITED

Transmission Division: Cray Works, Sevenoaks Way,
Orpington, Kent. Tel. Orpington 26611



- Connects Seattle to Ketchikan (Alaska).
- Extending from San Francisco to Hawaii.
- From Oban (Scotland) to Clarenville (Newfoundland) extending to Sydney Mines (Nova Scotia). This system is known as TAT.
- From Oban to Cornerbrook (Newfoundland), known as CANTAT.



- Begins at Gairloch on the west coast of Scotland and extends to Torshavn (Faroes). Thence to Reykjavik (Iceland), known as SCOTICE.
- Linking Vestmannaeyjar in Iceland with Frederiksdal (Greenland) and Cornerbrook, Newfoundland — called ICECAN.
- Starts at Manahawkin (U.S.A.) terminating at Bermuda.

SELLING AGENTS

- Australia and New Zealand:**
Telephone Manufacturing Company (A'sia) Proprietary Limited, Sydney, New South Wales.
- Canada and U.S.A.:**
Telephone Manufacturing Company Limited, Toronto, Ontario.
- All other Countries (for transmission equipment only):**
Automatic Telephone and Electric Company Limited, London.

STC



COAXIAL LINE OSCILLATORS

COMMERCIAL CODE	CV NUMBER	BASE	DIMENSIONS		FREQUENCY RANGE Mc/s	MINIMUM POWER OUTPUT W	RESONATOR VOLTAGE RANGE V	CATHODE CURRENT mA	MINIMUM ELECTRONIC TUNING RANGE Mc/s
			OVERALL LENGTH (mm)	MAXIMUM DIAMETER (mm)					
V190C/1M	—	B8G	114.3	31.8	800-1000	2	180-270	80	±2
V218A/1K	—	B7G	73	20.1	1700-2000	0.5	200-300	50	—
V231C/1K	—	B7G	80	20.1	3060-3180	0.05	180-240	45	±8
V233A/1K	2190	B7G	73	20.1	2700-4200	0.3	190-380	50-65	±1
V235A/1K	2221	B7G	73	20.1	2700-4000	0.5	190-350	50-65	±1
V237C/1K	—	B7G	80	20.1	3560-3820	0.35	225-285	45	±4
V238A/1K	—	B7G	88	20.1	3500-4300	0.55	260-400	50	±1
V239C/1K	5048	B7G	80	20.1	3780-4040	0.35	225-285	45	±4
V241C/1K	5049	B7G	80	20.1	4000-4240	0.35	225-285	45	±4
V243A/2F	—	*	81	20.1	4100-4600	0.75	235-275	65	—
V245C/1K	—	B7G	80	20.1	4400-4630	0.2	230-265	50	±8.5
V246A/2K	485	B7G	89	19.8	4580-4860	0.25	200-250	65	±3
V246C/4K	2422	B7G	89	20.1	4400-4850	0.3	280-360	50	±3
V247C/1K	—	B7G	80	20.1	4570-4750	0.2	230-265	50	±8.5
V249C/1K	—	B7G	80	20.1	4760-5000	0.2	240-290	50	±8

*B7G/F base fitted with P.T.F.E. wiring-in adaptor.



Standard Telephones and Cables Limited

Registered Office: Connaught House, Aldwych, London W.C.2

VALVE DIVISION: FOOTSCRAY · SIDCUP · KENT

PROPAGAS

PROPANE

carries weight
in the
building industry

Propane and Butane are now available to industry from the great British refineries of the Shell, Eagle and BP Groups. They are petroleum gases delivered and stored as liquids under moderate pressure. The Chinook Heater operated on **Propane** is ideally suited for drying out of buildings, heating workshops, stores, repair sheds and working in open sites, also for preheating frozen plants and equipment.

For full details of these and other products including Floodlighting and Space Heating equipment, apply now to :



SHELL-MEX AND B.P. GASES LIMITED

(Regd. users of trade marks)

"The biggest distributors of Propane in the U.K."

CECIL CHAMBERS 76-86 STRAND LONDON WC2 Telephone: TEMple Bar 1234



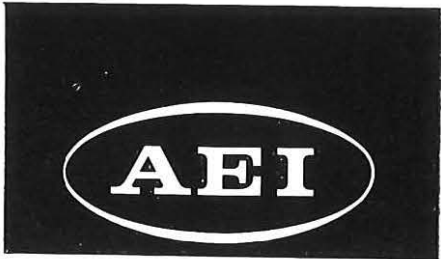
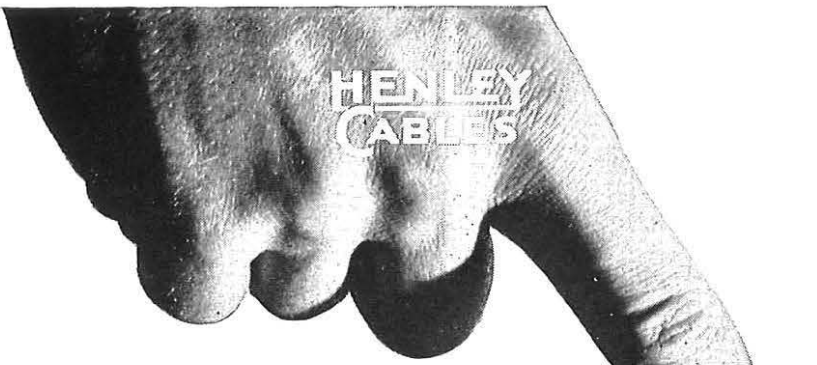

**A NEW SYMBOL
FOR
COMMUNICATION
CABLES**

In the communication cables field the new drum symbolises the combined resources of Henley, Liverpool Cables and Siemens Ediswan. For communication cables of all types—paper, plastic or textile insulated—small switchboard wires, local distribution and trunk type cables or composite co-axial cables—including loading coil accessories—A.E.I. leadership is unsurpassed. YOU CAN RELY ON A.E.I.

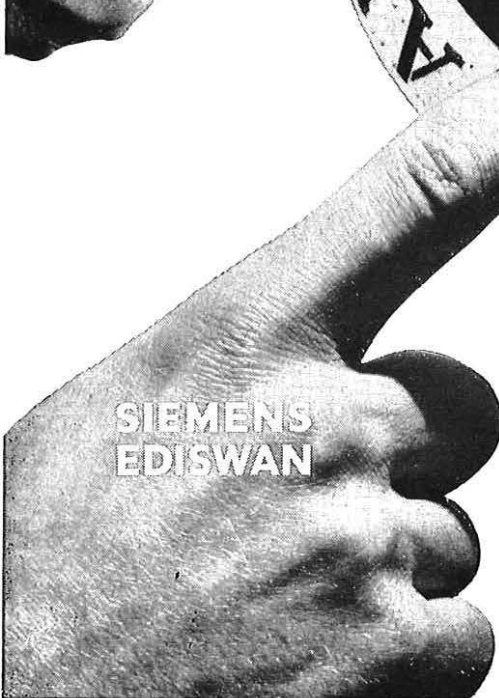
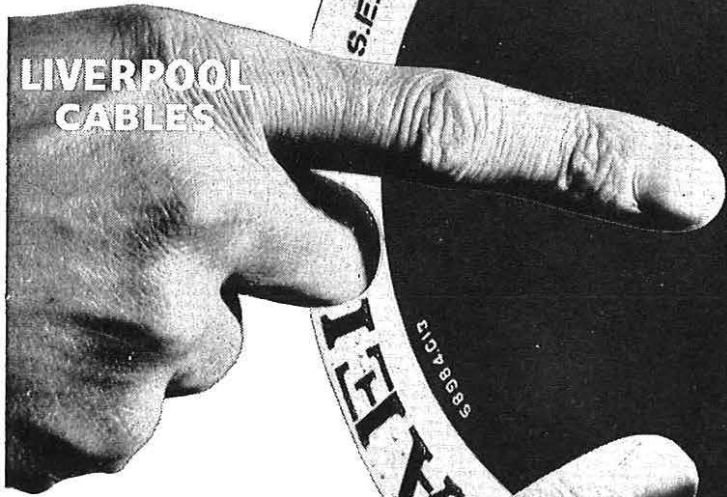

A E I CABLE DIVISION
TELEPHONE CABLE DEPARTMENT
Associated Electrical Industries Ltd.,
Woolwich, London, S.E.18 Telephone: Woolwich 2020





Rectifiers

FOR

ANGLO-SWEDISH SUBMERGED COAXIAL CABLE

CÖTEBORG

MIDDLESBROUGH

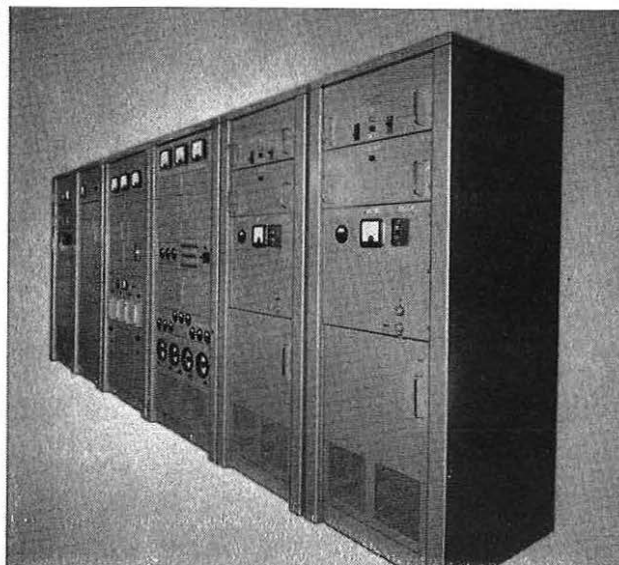

To meet the requirements of d.c. power supplies for submerged repeaters Westinghouse have developed a range of equipments which employ a transducer regulator, controlled by means of a magnetic discriminator.

The complete equipment illustrated above, which is being supplied for the Anglo-Swedish cable system, consists of a suite of six cubicles comprising three constant current units, two control cubicles, power separation filter and cable terminating cubicle. Complete indication, alarm, interlock and test facilities are built into the equipment.

Other equipments are at present in the course of being supplied for the Transatlantic Cable and System, H.M.T.S. Monarch, and the Bermuda Manahawkin Link.

For full details of Westinghouse rectifiers for telecommunications please write to Dept. P.O. 1, Rectifier Division (Special Products)

WESTINGHOUSE BRAKE AND SIGNAL CO. LTD • 82 YORK WAY, KING'S CROSS • LONDON, N1.

Terminus 6432

PAINTON Miniature Vitreous Wirewound Resistors

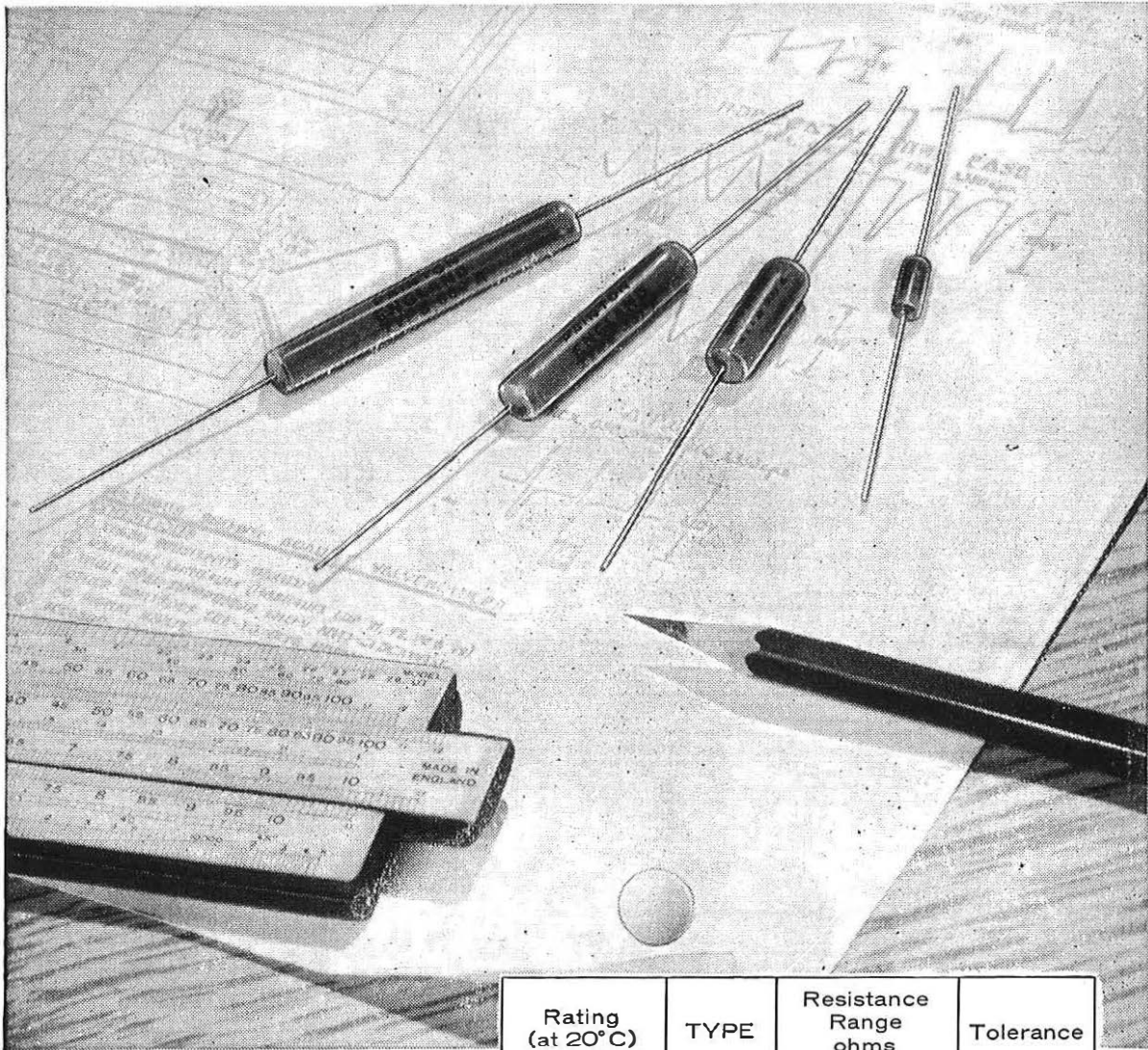

Rating (at 20°C) Watts	TYPE	Resistance Range ohms		Tolerance
		Min	Max	
4	MV1A	1	9.9	10%
		10	6,800	
7	301A	2	68,000	5%
10	302A	4	140,000	5%
5	306A	1	33,000	5%

Protected by Patent Nos. 626128 & 676279



Painton & Co. Ltd.
 KINGSTHORPE NORTHAMPTON
 Tel: 34251 (10 lines) Telegrams: 'Ceil Northampton'
 Telex 31574

- ★ Fully Type Approved to RCS 111
- ★ Top Quality ★ Quick Delivery
- ★ Competitive Prices

Always specify Painton Wirewounds

MORRISON OF SOUTHAMPTON

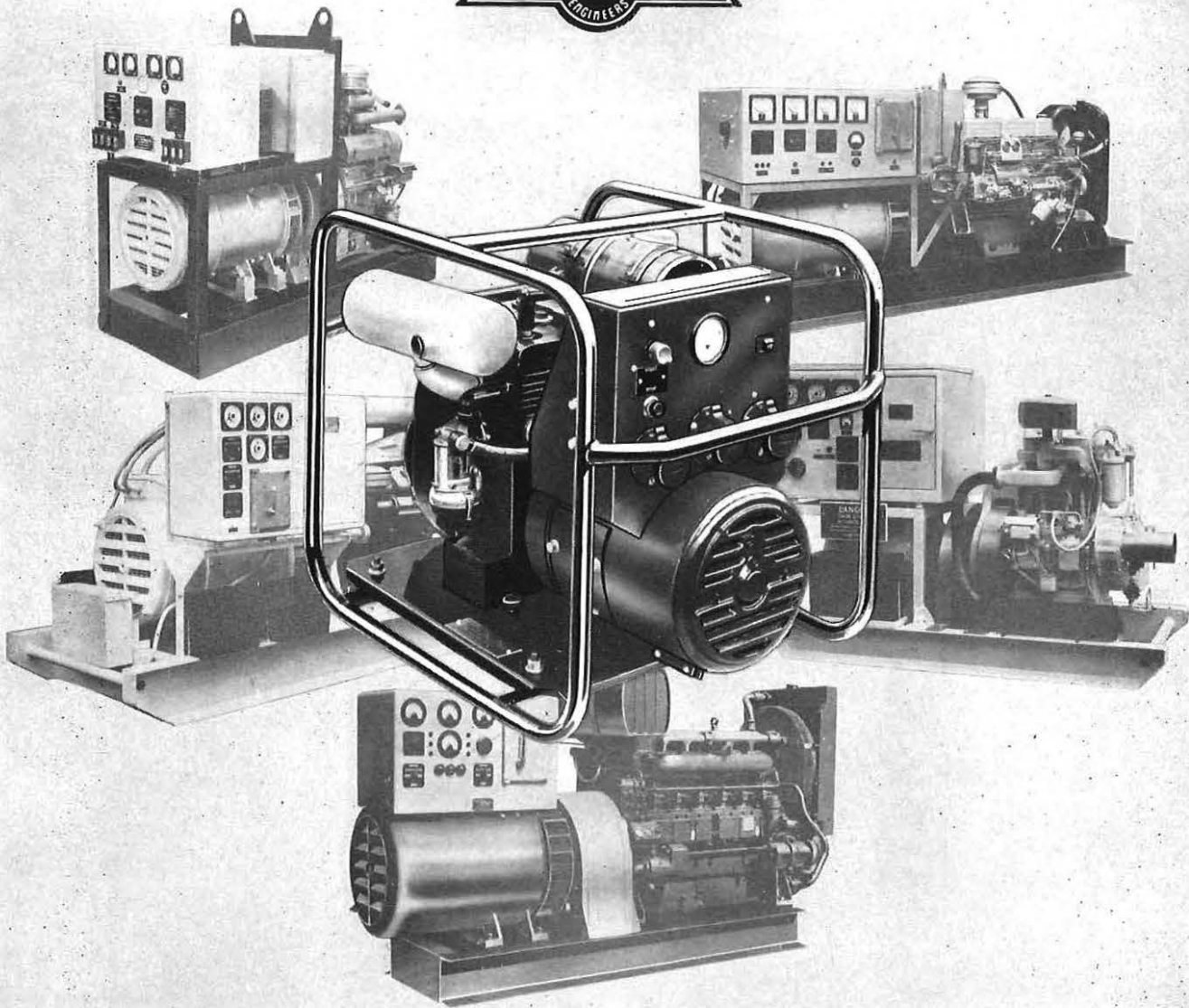

Against a background of typical larger generating sets is shown the latest product from Morrison of Southampton. Nine hundred of these 550 watt 24 volt petrol charging and general purpose units have been ordered by the British Post Office, the second contract of its type awarded to Morrison in recent years.

Morrison of Southampton manufacture individually designed generating sets up to 250 KW for British and Overseas Governments and industrial users. Morrison experience embraces a particularly wide field and equipment with complex control systems is our speciality.

A. C. MORRISON (ENGINEERS) LTD., SOUTHAMPTON, ENGLAND

Telephone 27362

ELECTRICAL ENGINEERS AND MANUFACTURERS

An Associated British Engineering Company

STC

PLAN, DESIGN, MANUFACTURE AND INSTALL COMPLETE S.H.F. SYSTEMS FOR TELEPHONE AND TELEVISION TRANSMISSION

STC can supply microwave radio systems complete with the necessary cable extensions and frequency division multiplex equipment.

STC EXPERIENCE

STC have supplied 4000 Mc/s systems having a capacity of over 4½ MILLION Telephone circuit miles and over 5000 Television channel miles.

STC are supplying systems to 18 countries

4000 Mc/s Terminal equipment cubicles.

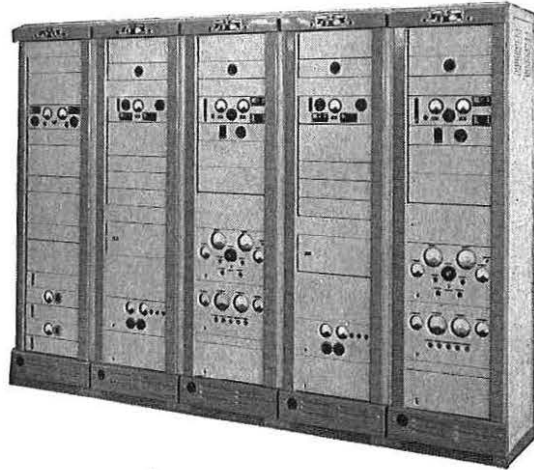

Experienced STC engineers are ready to help solve your communications problems.

Standard Telephones and Cables Limited

Registered Office: Connaught House, Aldwych, London, W.C.2

TRANSMISSION DIVISION: NORTH WOOLWICH · LONDON · E.16

For Your Next Project

ATE

Transmission Equipment

TYPE CM

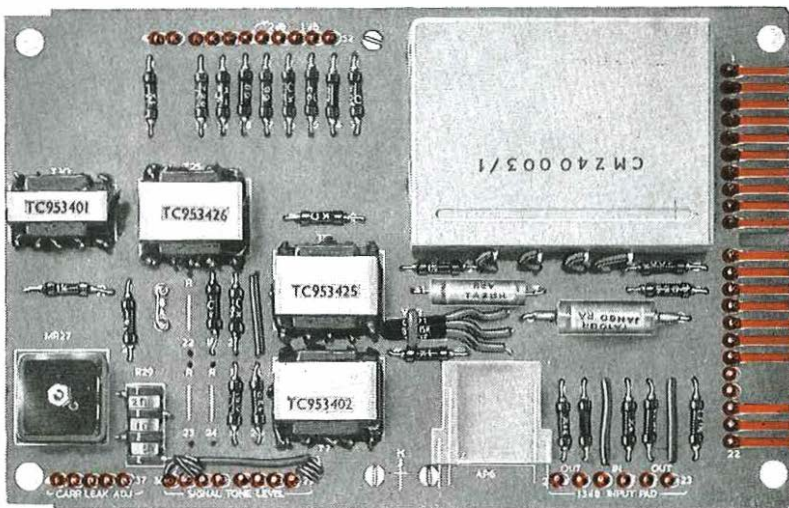

Front and back of channel equipment board, half actual size.

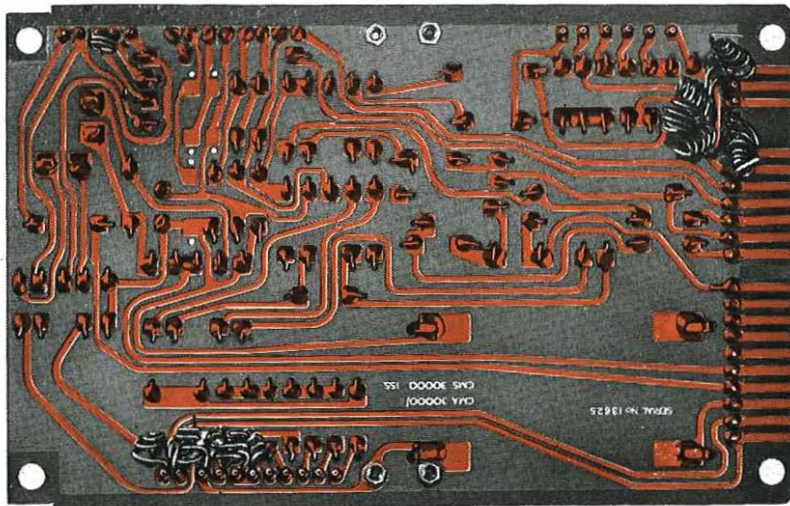

THESE PHOTOGRAPHS of a typical Type CM sub assembly show that printed wiring, transistors, ferrites, tantalum capacitors and gold-plated contacts are just some of the more obvious features of the compact equipment design.

To the user, the fact that every feature has been submitted to the most prolonged and painstaking proving before production is equally important and an assurance that maintenance and installation requirements have been minimised.

*For further
information on Type
CM equipment write
for Bulletin TEB 3001 to:—*



AUTOMATIC TELEPHONE & ELECTRIC CO. LTD.

STROWGER HOUSE, ARUNDEL STREET, LONDON, W.C.2

TELEPHONE: TEMPLE BAR 9262

60,000 lines of print
from the . . .

ERICSSON PRINTING RECORDER

Designed specifically for recording the time of events on a Subscriber's telephone line, this RECORDER will print

FOR INCOMING CALLS:—

Time of connection, answer and completion.

FOR OUTGOING CALLS:—

Time of connection, digits dialled, meter pulses and completion.

A typical example of trunk call and incoming call recording is shown.

Flexible in design, the unit can be readily adapted to other requirements and could find many applications in the field of data handling.

special features

Autograph aperture for manuscript entries on record.

Paper may be manually advanced with cover on.

Paper may be fed out of the unit through rear of cover.

Rear of base is cut away to permit wall, rack or table mounting.

Carrying handle is associated with the apparatus, not with the cover.

Easy interpretation of clock marking by use of mirror and correction factor.

5" diameter paper roll permits 60,000 lines of print.

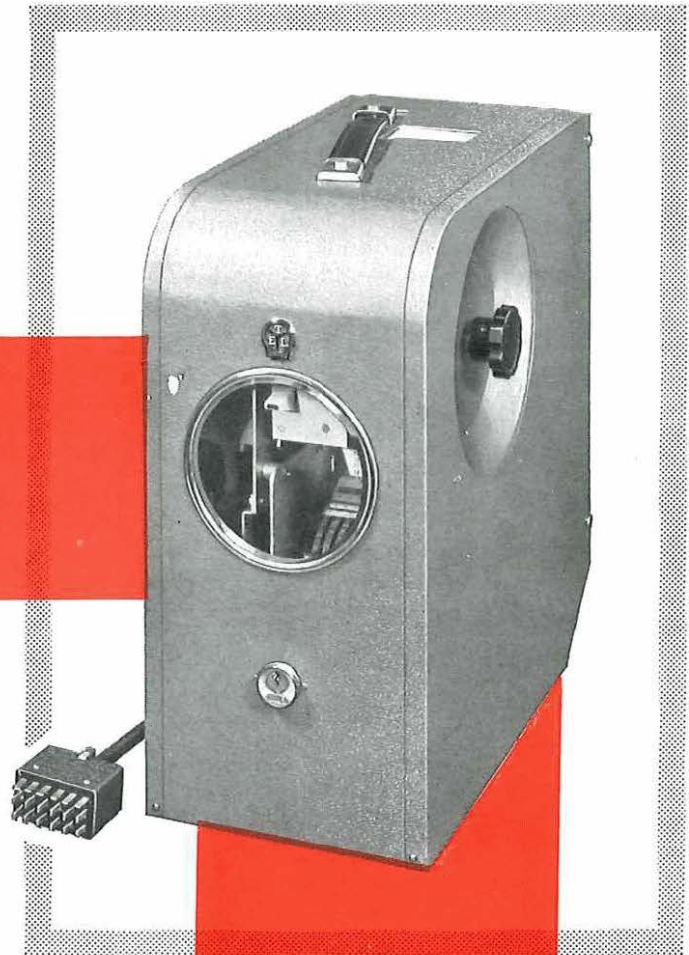

	START	AREA	DAY	HOUR	MINUTE	SECOND
0	12	3	11	30	11	
3	12	3	11	30	4	
0	12	3	11	30	5	
4	12	3	11	30	6	
2	12	3	11	30	7	
3	12	3	11	30	7	
4	12	3	11	30	8	
5	12	3	11	30	8	
1	12	3	11	30	20	
2	12	3	11	30	20	
	M	12	3	11	30	29
	M	12	3	11	30	41
	M	12	3	11	30	53
	M	12	3	11	31	05
	M	12	3	11	31	17
	M	12	3	11	31	29
	M	12	3	11	31	41
	M	12	3	11	31	53
	M	12	3	11	32	05
	M	12	3	11	32	17
	M	12	3	11	32	29
	M	12	3	11	32	41
	M	12	3	11	32	53
	M	12	3	11	32	57
	M	12	3	11	45	07
	M	12	3	11	45	17
	M	12	3	11	45	19



ERICSSON TELEPHONES LIMITED • ETELCO LIMITED

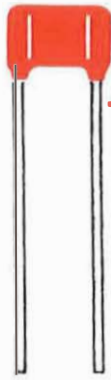

NEW

HIGH TEMPERATURE CAPACITORS

efficient at **250°C**

Type H precision silvered mica capacitors—the latest addition to the JMC range—are suitable for use from -70°C to $+250^{\circ}\text{C}$. Silicone rubber protection safeguards their outstanding performance at very high operating temperatures.

- ★ Fired construction
- ★ Two standard sizes covering all values from $5\mu\text{F}$ to $50,000\mu\text{F}$
- ★ Minimum tolerance $\pm 1\%$ or $\pm 1\mu\text{F}$ (whichever is greater)
- ★ Small physical size
- ★ Silver or silver-clad connecting leads

Catalogue sheets describing the complete range of JMC precision capacitors are available on request

Johnson  Matthey

JOHNSON, MATTHEY & CO., LIMITED
 73-83 HATTON GARDEN, LONDON, E.C.1 Telephone: Holborn 6989
 Vittoria Street, Birmingham, 1. Telephone: Central 8004
 75-79 Eyre Street, Sheffield, 1. Telephone: 29212

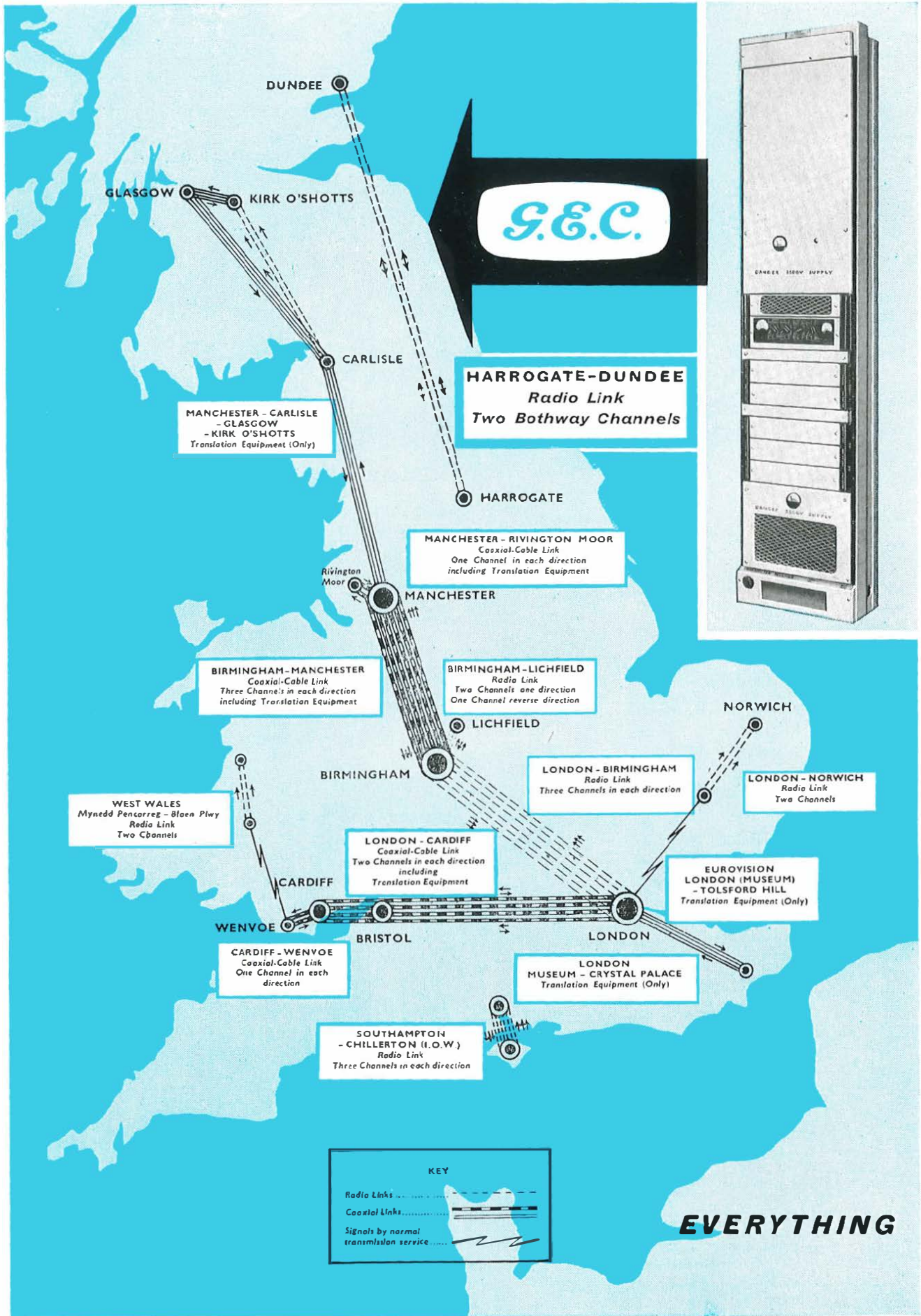

SHF

Broadband Radio Equipment

again

selected by the

BRITISH POST OFFICE

G.E.C. has been awarded the contract to supply and install two bothway radio channels between Dundee and Harrogate, the first stage of the new national broadband microwave network. Operating in the 6000 Mc/s frequency band, the system will consist of six hops. One of the two channels will be used as the working channel and the second as the standby. Provision is made for the system to be extended to have five working channels with one common standby channel.

The equipment, which conforms to the latest CCIR recommendations is capable of conveying either a television circuit or 960 speech circuits.

Ever since the introduction of its 2000 Mc/s radio equipment, the aim of the G.E.C. has been to develop a larger capacity equipment embodying the same high standard of performance and reliability and the same ease of maintenance that have gained for the Company's UHF equipment so high a reputation with Telephone Administrations throughout the world.

Development of the new equipment began in 1954. It was found that our design objectives could not economically be achieved in the 2000 Mc/s band. Development was therefore transferred to the SHF bands of which the 6000 Mc/s band was finally chosen because of our firm belief that within the next few years the 4000 Mc/s band would become increasingly congested. The current B.P.O. and overseas contracts have fully justified our early decision.

For further information, please write for Standard Specification SPO 5555

FOR TELECOMMUNICATIONS

THE GENERAL ELECTRIC COMPANY LIMITED OF ENGLAND
Telephone Works · Coventry · England
Works at Coventry · London · Middlesbrough · Portsmouth



G.E.C.

STC

TELECOMMUNICATION CABLES

96 Pair Subaqueous cable

24 Pair cable for aerial or duct installation

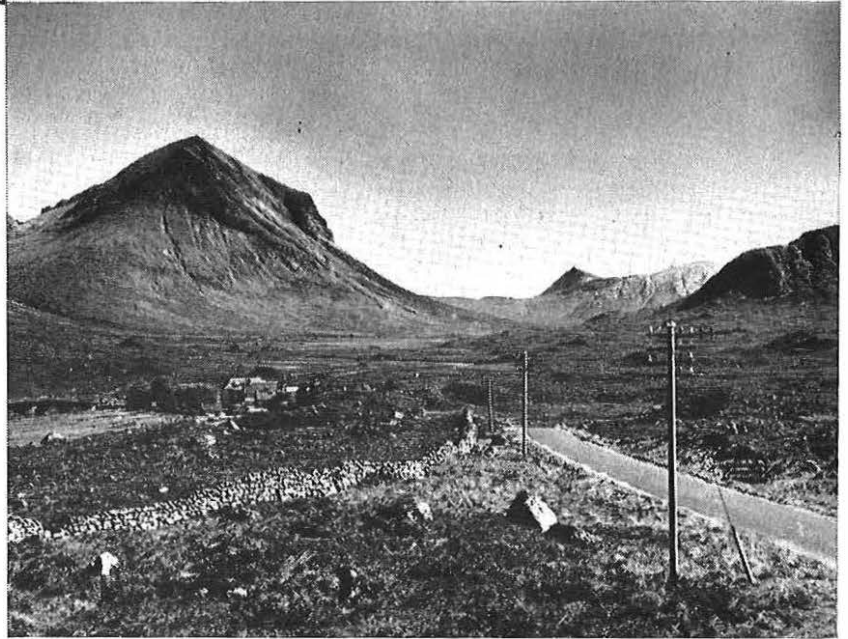

for the Isle of Skye

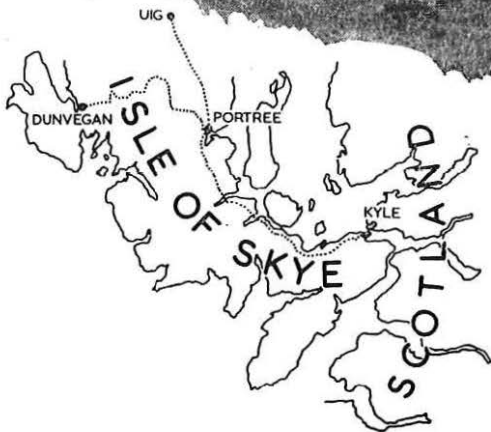
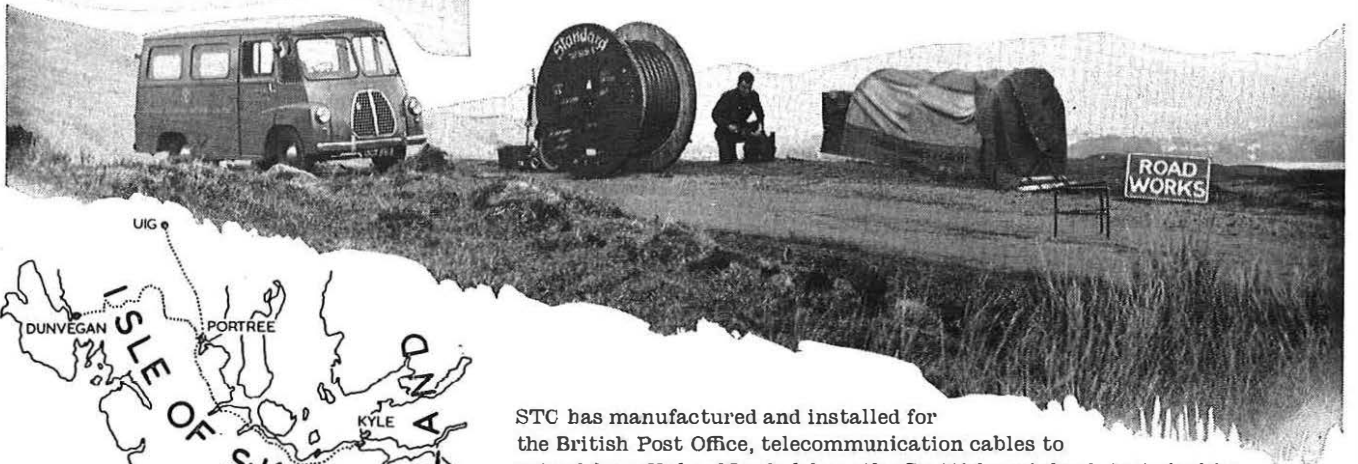

STC has manufactured and installed for the British Post Office, telecommunication cables to extend from Kyle of Lochalsh on the Scottish mainland, to Kyleakin, and thence to Portree, Uig, Dunvegan and other townships en route. These voice frequency, lead-covered and protected cables are of 20 lb/mile conductors and contain from 14 to 122 pairs. The Isle of Skye is familiar ground to STC who have previously laid cables in this area.



Standard Telephones and Cables Limited

Registered Office: Connaught House, Aldwych, London, W.C.2

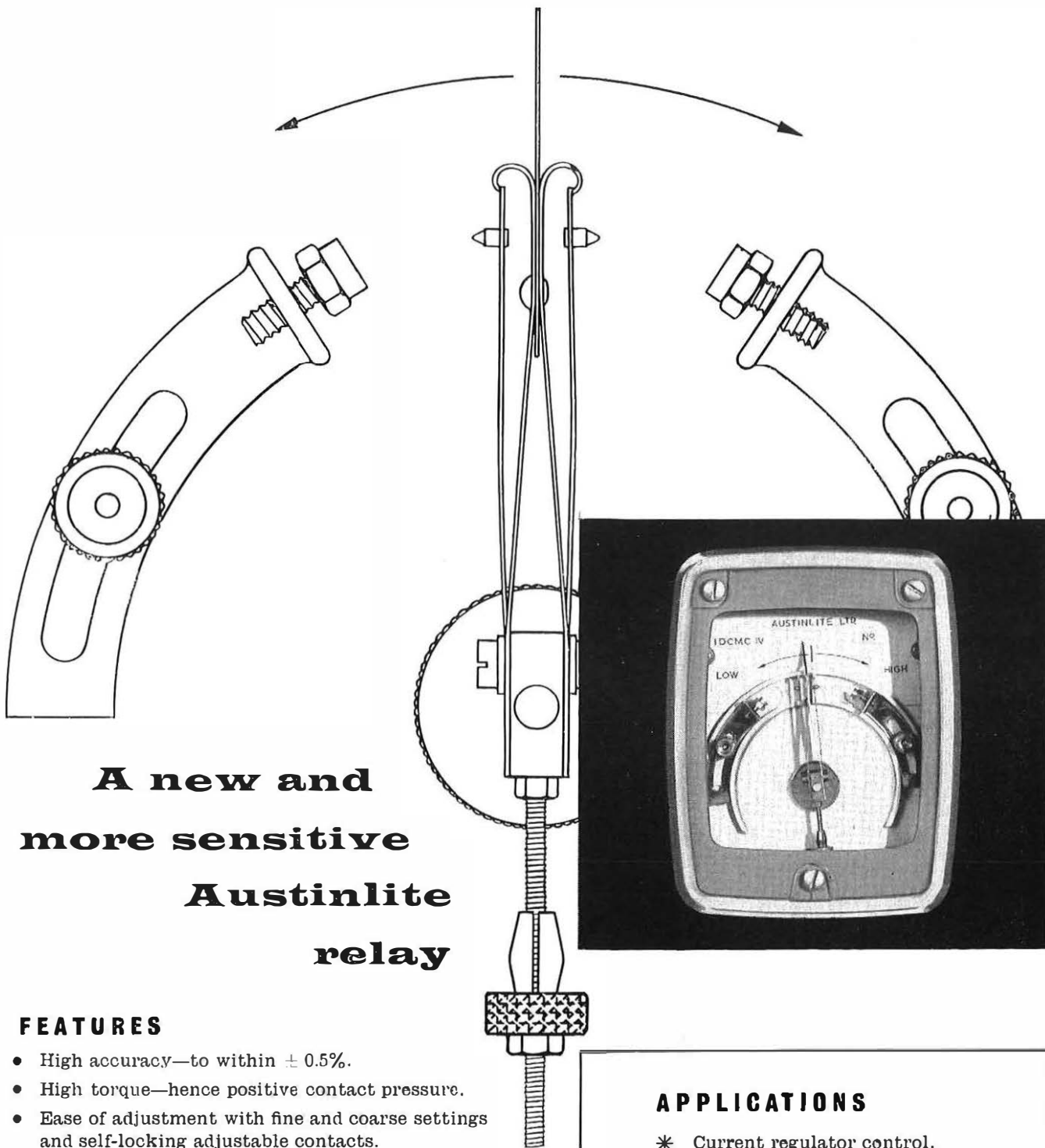

**A new and
more sensitive
Austinlite
relay**

FEATURES

- High accuracy—to within $\pm 0.5\%$.
- High torque—hence positive contact pressure.
- Ease of adjustment with fine and coarse settings and self-locking adjustable contacts.
- Choice of either two or four adjustable contacts.
- Contemporary case design—projection or flush mounting.
- Dustproof and suitable for use in the tropics.
- Conforms to Post Office Specification P.T. 1025B.
- Suitable for current or voltage sensing on either D.C. or A.C.

APPLICATIONS

- * Current regulator control.
- * Voltage regulator control.
- * Monitoring duties.
- * Limiting duties.
- * Equipment protection.

Austinlite **ELECTRICAL EQUIPMENT**
Custom-built by STONE-CHANGE LTD.

(Makers of Sumo Pumps and
 Stone-Change Lighthouses).
 CRAWLEY, SUSSEX.

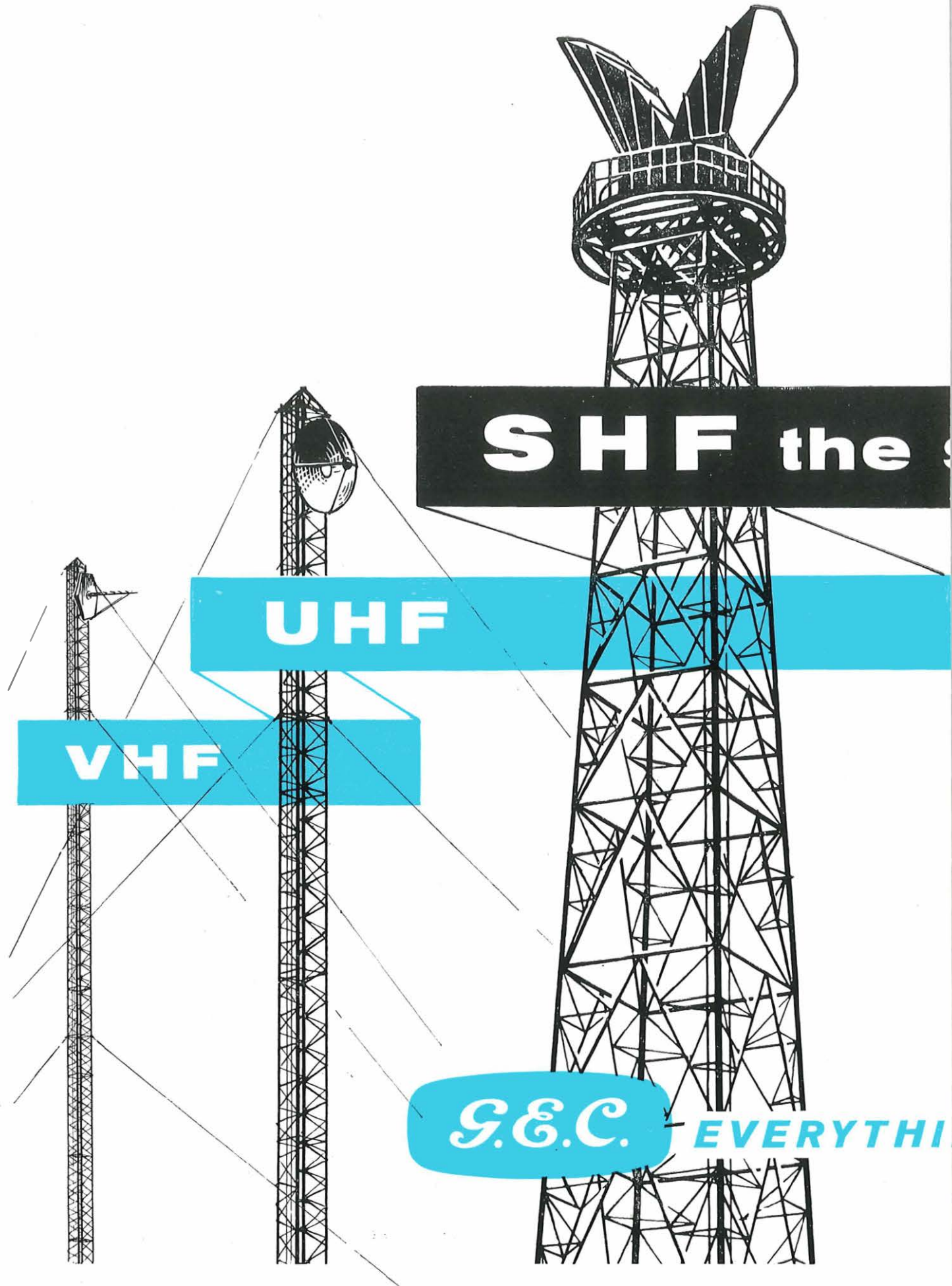

SHF the s

UHF

VHF

G.E.C.

EVERYTHI

For the largest capacity systems

consult

G.E.C.

system for the 60's

Great difficulty has been experienced by Administrations in planning nation-wide radio networks employing one frequency band. By using broad-band radio equipment in two different frequency bands the problem of frequency allocation is greatly simplified. G.E.C. are now supplying two types of long haul radio system, one operating in the SHF frequency band and the other in the UHF frequency band, in addition to small capacity systems operating in the VHF frequency bands. The complete range is given below:

System	SPO. 5555	SPO. 5502	SPO. 5060	SPO. 5052	SPO. 5051
Frequency bands	5925—6425 Mc/s	1700—2300 Mc/s	132—156 Mc/s 156—184 Mc/s 235—270 Mc/s	445—475 Mc/s	71.5—100 Mc/s 132—156 Mc/s 156—184 Mc/s 235—270 Mc/s
Capacity	(a) 960 speech circuits arranged in 16 supergroups or (b) 900 speech circuits arranged in 3 master-groups or (c) monochrome or colour television (405, 525 or 625 line) or (d) monochrome television plus sound channel	(a) 300 speech circuits or (b) monochrome or colour television (405, 525 or 625 line)	9 speech circuits	5 speech circuits	5 speech circuits

*G.E.C. offers a complete service
from original survey to final commissioning*

IG FOR TELECOMMUNICATIONS

For further information please write to:

THE GENERAL ELECTRIC COMPANY LIMITED OF ENGLAND
TELEPHONE WORKS · COVENTRY · ENGLAND
Works at Coventry, Middlesbrough, London, Portsmouth

Smee's G.E.C. 77

Improved splice loading with the L219

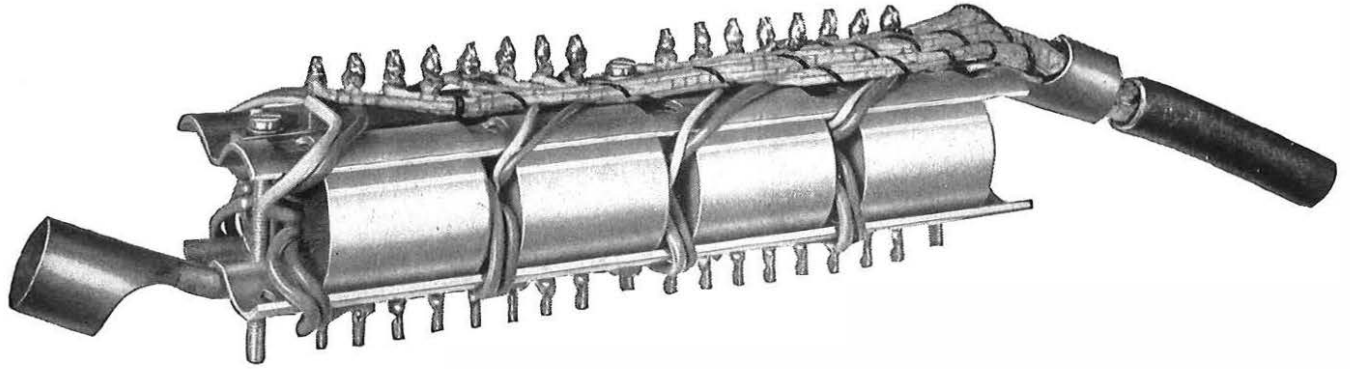

The new
economical
loading coil

Arising from the increasing demand for a smaller coil which can be employed in splice loading, the L219 has been developed. In the design Mullard Equipment Limited were assisted by their own production experience and information given by overseas users. The result is a simple, low cost component (to grade 3 spec.) suitable for small or large splice loading units.

Smaller
construction

By using a new grade of Ferroxcube pot core the overall volume of the coil is considerably reduced. The coil is resin sealed in a small cylindrical aluminium canister ensuring complete protection from climatic effects. The windings of the coils are brought out on flying leads.

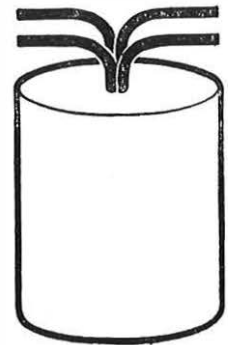

LIFE SIZE COIL
L219

Permits
smaller
splices

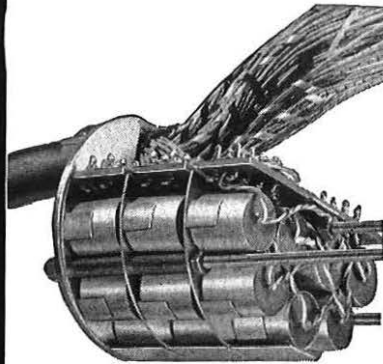

Key factors in this development are the clamping arrangements which, with the new coil, permit much smaller splice housing. On small cables, coils are mounted lengthways in pairs with great compactness. For larger cables, coils are mounted radially, each mounting plate accommodating up to seven coils. Clamping plates, coils, etc. can be supplied as kits.

Please write for full details of these new loading coils

MULLARD EQUIPMENT LIMITED

MULLARD EQUIPMENT LIMITED

Mullard House · Torrington Place · London W.C.1 · Telephone: Langham 6633

TOUGH AS NAILS!



**HIGH
IMPACT
MOULDINGS
for the new
ETELPHONE**

... visible proof of the amazing quality of these new High Impact Mouldings.

The case and handset of the standard ETELFONE and PLAN-ETELPHONE instruments are acrylic mouldings and have adequate strength for what is regarded as ordinary usage. However, from time to time telephone instruments are required to withstand very rough usage and for this sort of

service instruments with mouldings of high impact materials are available. These materials have impact strengths ten or more times greater than ordinary acrylic and phenolic plastics and the mouldings will withstand such treatment which, in ordinary terms, would justify the use of the word "unbreakable".

All types of Etelphone, Plan-Etelphone and Magneto-Etelphone are offered in high impact materials, normally in black, but if a sufficient quantity is ordered other colours of the standard Etelphone range could be made available.

Further details on request.



ERICSSON TELEPHONES LIMITED • ETELCO LIMITED

HEAD OFFICE:—22, LINCOLN'S INN FIELDS, LONDON, W.C.2. TEL. HOL. 6936

PRECISE TEMPERATURE CONTROL

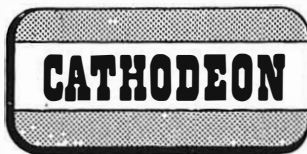
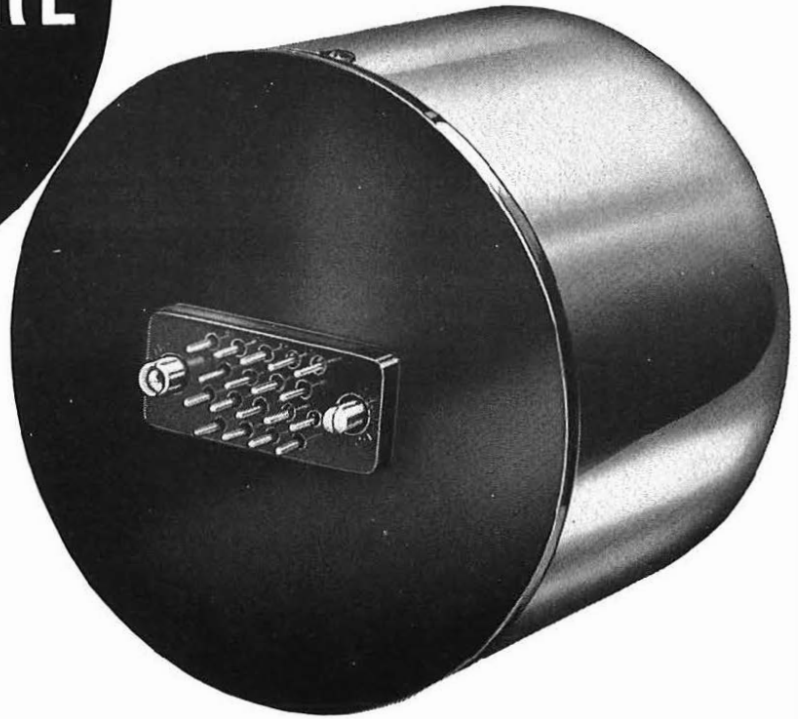

The latest addition to the range of thermostatically controlled ovens is this "plug-in" version, type B5. The Oven provides up to thirteen connections on an 18-way plug and is ideal for quartz crystals, diodes, transistors and other devices which are sensitive to ambient temperature changes.

Temperature Settings from 45°C to 85°C.
Temperature differential better than $\pm 1^\circ\text{C}$
from -20°C to the operating temperature
less 10°C .

External diameter $3\frac{1}{8}$ "
Internal space $1\frac{3}{4}$ " dia. x $\frac{5}{8}$ "
Power Supply 6v, 12v, or 24v.
Weight 8 oz.

*Send for details of this unit or for any of our range of Ovens
now available in production quantities.*

CATHODEON CRYSTALS LIMITED

LINTON CAMBRIDGESHIRE

TELEPHONE LINTON 501 (4 lines)



STC plan, engineer, manufacture and install complete submarine communication systems:

SUBMARINE TELEPHONE AND
TELEGRAPH CABLES

SUBMERGED REPEATERS
TERMINAL EQUIPMENT



STC

systems and equipment for
submarine communications



Standard Telephones and Cables Limited

TELECOMMUNICATIONS AND ELECTRONICS

CONNAUGHT HOUSE · 63 ALDWYCH · LONDON · W.C.2.



TUNGSTONE BATTERIES have been designed to meet Post Office, British Standards and other national Post and Telegraph Specifications. They are being used in Power Stations, Telephone Exchanges, etc., all over the United Kingdom, Australia, India, South Africa, West Africa, West Indies, Portugal, Venezuela, etc.

This illustration shows . . . the installation of a 126 cell TUNGSTONE Battery, Type BSSF99 giving capacity of 800 a.h. at the 9 hr rate.

TUNGSTONE PRODUCTS LTD

Salisbury Square, London, E.C.4. Telephone: LUDgate Circus 0342

WORKS: Market Harborough, Leics.



specify

H

gold
bonded
germanium

diodes

- ★ **HG5003 is designed to meet CV7127**
- ★ **Fast recovery and low hole storage**
- ★ **High forward conformance**
- ★ **Low reverse leakage**
- ★ **High peak inverse voltage**

Made in Glenrothes, Scotland, the Hughes range of silicon and germanium diodes are subminiature devices with extremely stable electrical and mechanical characteristics. These diodes are specially designed and constructed to meet the most exacting requirements of military or commercial applications. They are double wire ended and fusion-sealed in a subminiature one-piece glass envelope to ensure complete isolation of the active elements from damage or contamination. The small size, combined with rigidity of construction and small mass of the elements, enable them to successfully withstand physical shock and vibration.

Qualified engineers in our Research and Development laboratories at Glenrothes are available to help with your application problems.

	Type No.	Continuous ratings 25°C		Characteristics 25°C	
		Max. Reverse Volts	Max. Forward Current	Max. Volts Drop	Max. Reverse Current
Actual size	HG5001	100	80 mA	.8 v @ 100mA	5μA @ -50V
	HG5002	70	80 mA	.8 v @ 100mA	5μA @ -50V
	HG5003	100	80 mA	.8 v @ 100mA	25μA @ -50V
	HG5004	70	80 mA	.8 v @ 100mA	25μA @ -50V
	HG5005	100	80 mA	.8 v @ 100mA	50μA @ -50V
	HG5006	70	80 mA	.8 v @ 100mA	50μA @ -50V
	HG5007	40	80 mA	.8 v @ 100mA	5μA @ -30V
	HG5008	40	80 mA	.8 v @ 100mA	25μA @ -30V
	HG5009	40	80 mA	.8 v @ 100mA	50μA @ -30V

Home and Overseas enquiries to:

HUGHES INTERNATIONAL (U.K.) LTD
KERSHAW HOUSE, GREAT WEST ROAD, HOUNSLOW, MIDDLESEX HOUNSLOW 5222

INDEX TO ADVERTISERS

	PAGE		PAGE
Adcola Products, Ltd.	8	National Salt Glazed Pipe Manufacturers' Association . .	11
Associated Electrical Industries, Ltd.	16	Neill, James, & Co. (Sheffield), Ltd.	5
Automatic Telephone & Electric Co., Ltd.	6-7, 21	Painton & Co., Ltd.	18
Avo, Ltd.	1	Pitman, Sir Isaac, & Sons, Ltd.	5
Bennett College, The	5	Pye Telecommunications, Ltd.	4
British Institute of Engineering Technology	8	Shell-Mex & B.P. Gases, Ltd.	15
Cathodeon Crystals, Ltd.	32	Smith, Frederick, & Co.	8
Ericsson Telephones, Ltd.	22, 31	Standard Telephones & Cables, Ltd.	14, 20, 26, 33, 38
Formica, Ltd.	9	Stone-Chance, Ltd. (Austinlite)	27
General Electric Co., Ltd., The	24-25, 28-29	Stonebridge Electrical Co., Ltd., The	36
Great Northern Telegraph Co., Ltd.	10	Telephone Manufacturing Co., Ltd.	12-13
Hughes International (U.K.), Ltd.	35	Tungstone Products, Ltd.	34
Johnson, Matthey & Co., Ltd.	23	Turner, Ernest, Electrical Instruments, Ltd.	2
Marconi's Wireless Telegraph Co., Ltd.	3	Westinghouse Brake & Signal Co., Ltd.	17
Morrison, A. C. (Engineers), Ltd.	19	Whiteley Electrical Radio Co., Ltd.	1
Mullard, Ltd.	30, 37	Winn & Coales, Ltd.	2

SUBSCRIBER TRUNK DIALLING METERS

Adopted for the new scheme for the United Kingdom and commencing at **BRISTOL**, these counters are part of a British-made range available for telephone and other systems. The designs are based on extensive Continental experience.



THE STONEBRIDGE ELECTRICAL CO. LTD.
 6 QUEEN ANNE'S GATE • LONDON, S.W.1 Telephone : TRAfalgar 1444



Agents and Licensees in U.K. for 'SODECO' Geneva

NEW VINKOR SERIES

Covers frequencies from 100 Kc/s to **2** Mc/s

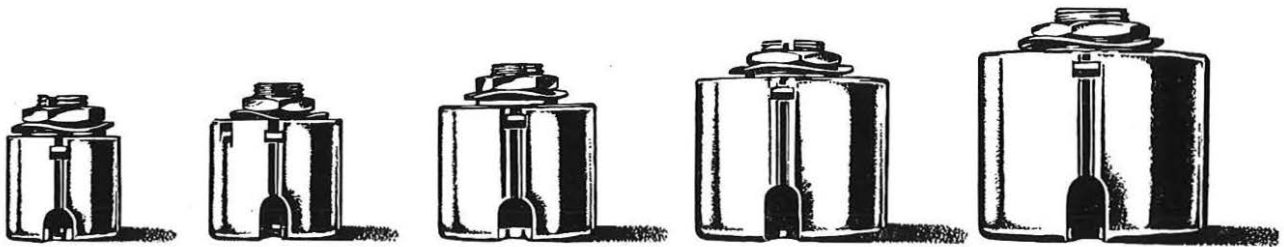

A new series of Vinkor adjustable pot cores has been developed by Mullard for use in the frequency range 100 kc/s to 2Mc/s. This series is in addition to the highly successful group already widely used for frequencies between 1 kc/s and 200 kc/s.

The world's most efficient pot core assembly, the Mullard Vinkor gives a choice of 3 permeabilities and has exceptionally high performance and stability. Write today for full details of the wide range of Vinkors now available.

Mullard **VINKOR**

ADJUSTABLE POT CORE ASSEMBLIES



MULLARD LTD., COMPONENT DIVISION, MULLARD HOUSE, TORRINGTON PLACE, W.C.1.

MCI



These new *STC* complete packaged oscillator units represent a revolutionary step forward in crystal design. They are extremely small units for use as laboratory references or as the oscillator section of high performance equipment. The ruggedness of design together with the small size makes possible a degree of portability hitherto unknown in this type of unit. Standard frequency is 5 Mc/s.

Write for Technical Data Sheets.

**1 in 10^9 per day
frequency
standard for
laboratories
at £195**

*One of a new, low priced range of
frequency standards from *STC*.*

- **Rugged**
- **Compact**
- **Light-weight**
- **Reliable**
- **Low Cost**



6011 MO

Standard Telephones and Cables Limited

Registered Office: Connaught House, Aldwych, W.C.2.

QUARTZ CRYSTAL DIVISION: HARLOW · ESSEX