

# THE POST OFFICE ELECTRICAL ENGINEERS' JOURNAL

Vol. 47

APRIL 1954

Part 1

## CONTENTS

	PAGE
A SMALL EXPERIMENTAL ELECTRONIC AUTOMATIC TELEPHONE EXCHANGE, Part 1—The Transmission System and Basis of Setting-up Connections—F. Scowen, B.Sc., A.Inst.P., A.M.I.E.E. . . . .	1
A TELEGRAPH DISTORTION ANALYSER—L. K. Wheeler, B.Sc.(Eng.), A.M.I.E.E., and A. C. Frost, A.M.I.E.E. . . . .	5
FACILITIES FOR EXPERIMENTAL WORK IN THE ENGINEERING DEPARTMENT— W. West, O.B.E., B.A., M.I.E.E. . . . .	10
TRUNK TESTING AT ZONE CENTRE EXCHANGES—L. A. Missen . . . . .	15
A PHOTOGRAPHIC TECHNIQUE OF SOUND RECORDING ON GLASS DISCS— A. J. Forty, B.A., A.M.I.E.E. . . . .	19
IMPROVEMENTS TO THE 2000-TYPE SELECTOR—E. H. Seymour, A.M.I.E.E. . . . .	25
ELECTRONIC SOLUTION TO AN AGRICULTURAL PROBLEM . . . . .	29
AN IMPROVED 2-TON GENERAL UTILITY VEHICLE—G. H. Slater, A.M.I.E.E. . . . .	30
NEW ACCOMMODATION FOR THE TELEPHONE BRANCH CIRCUIT LABORATORY— M. Mitchell, M.B.E., B.Sc.(Eng.), A.M.I.E.E., and P. D. Corby, B.Sc.(Eng.), A.M.I.E.E. . . . .	33
AN APPLICATION OF THE MAGNETIC AMPLIFIER TO ROUTINE TESTING OF JUNCTION CIRCUITS—M. C. Stone . . . . .	39
POST OFFICE STANDARD P.A.B.X.s, Part 2—The P.A.B.X. No. 2—J. J. Roche . . . . .	41
HIGH-VOLTAGE POWER-CONDUCTOR DROPPING TESTS . . . . .	43
BRITISH CONTACT RESEARCH: LOUGHBOROUGH CONVENTION, 1952 . . . . .	46
NOTES AND COMMENTS . . . . .	49
REGIONAL NOTES . . . . .	52
INSTITUTION OF POST OFFICE ELECTRICAL ENGINEERS . . . . .	57
ASSOCIATE SECTION NOTES . . . . .	58
STAFF CHANGES . . . . .	60
BOOK REVIEWS . . . . .	9, 14, 24, 32, 38, 48, 51

Price 2/6 net

THE INSTITUTION OF POST OFFICE ELECTRICAL ENGINEERS

**The Ideal Receiver for Point-to-Point**

**and Ground-to-Air Channels**

✦ **A Fixed Frequency, Single Channel Receiver covering 2 to 20 Mc/s.**

The crystal-controlled R.93 is an important receiver which has been designed to operate over long periods under either temperate, arctic or tropical conditions at unattended sites. A number of R.93's may be stacked in standard 19" racks for multi-channel working on R.T. or W.T. Double or triple diversity racks can also be supplied with suitable terminal equipment for direct teleprinter operation from frequency shift transmission. Enquiries will receive immediate attention.

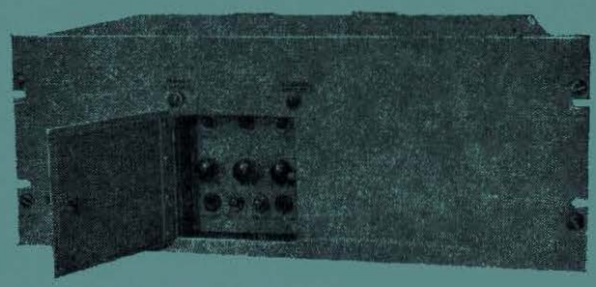

REDIFON LIMITED  
 RADIO COMMUNICATIONS DIVISION  
 BROOMHILL ROAD  
 LONDON, S.W.18  
 Phone: VANDYKE 7281

**Rediton**

DESIGNERS AND MANUFACTURERS OF RADIO COMMUNICATIONS AND INDUSTRIAL ELECTRONIC EQUIPMENT

**A. T. STARR**  
 has now written a comprehensive  
 treatise on theoretical and applied  
**Electronics**

Written by an acknowledged authority, ELECTRONICS covers the requirements of the Electronic syllabus for the London University B.Sc. Engineering Degree. It covers the physical fundamentals; types of valve; rectifiers and rectification; circuit theory; amplifiers, oscillators and detectors; and gives brief descriptions of typical electronic applications. Fully indexed and profusely illustrated with diagrams, this is an essential study for University students, and an invaluable work for practising engineers. 32/6 net.

A new addition to the  
**PITMAN ENGINEERING DEGREE SERIES**  
 Parker St. . Kingsway . London, W.C.2.

**How to make certain of your City & Guilds Certificates**



"I guarantee tuition until you have passed"

If you consider taking one or the whole series of C. and G. examinations then I can help you. BY POST, in your own time, one of my Telecommunications specialists will coach you until you pass. He will give you individual attention, he will study you and your problems. And you will be surprised how fast you progress. For The Bennett College has specialised in technical subjects since it was founded 50 years ago. My system of personal postal tuition has helped thousands of students through their exams. It can do the same for you.

Send me the coupon to-day. I will send you—without obligation—full information on your subject.

*W. Bennett*  
 GOVERNOR

YOU CAN START ON A BENNETT COURSE FOR ONLY **30/-** with monthly instalments of 15/-

**WHICH IS YOUR NEXT STEP ?**

- Preliminary Course
- Telecommunications Principles I—V
- Telecommunications Practice
- Telephone Exchange Systems I—III
- Radio I—IV
- Telegraphy I & II
- Line Transmission I & II
- Mathematics for Telecommunications I—V
- Radio Servicing Certificate
- Television Servicing Certificate
- A.M.I. Mech.E.
- and many other subjects

**The BENNETT COLLEGE**

To the Governor, Dept. D24, The Bennett College, Sheffield, England. I would like to have (at no cost) your prospectus and

particulars of \_\_\_\_\_  
 NAME \_\_\_\_\_  
 ADDRESS \_\_\_\_\_  
 AGE (if under 21) \_\_\_\_\_  
 PLEASE WRITE IN BLOCK LETTERS

# THE POST OFFICE ELECTRICAL ENGINEERS' JOURNAL

Vol. 47

April 1954

Part 1

## A Small Experimental Electronic Automatic Telephone Exchange

F. SCOWEN, B.Sc., A.Inst.P., A.M.I.E.E.†

### Part 1.—The Transmission System and Basis of Setting-up Connections.

U.D.C. 621.395.34:621.318.572:621.395.722

Part 1 of this article describes the principles of time-division-multiplex transmission and shows how such a transmission system can be adapted to act as a switching device. The use of a t.d.m. switching device to form an automatic telephone exchange is described and the operations of setting-up a connection through such an exchange are explained. Parts 2 and 3 will describe the equipment in some detail and will explain how the experimental 4-line exchange could be expanded to a 10,000-line exchange.

#### INTRODUCTION

THIS article describes a small model electronic automatic telephone exchange which was made during the course of a long-term investigation into the possibility of applying electronic techniques to automatic telephone exchange design. The model uses a time-division-multiplex switch and, although only 4 lines are connected to it, the ultimate capacity of the exchange is 99 lines. After describing the model, this article indicates how the capacity of the exchange can be increased up to 10,000 lines or more.

A series of three articles in this Journal<sup>1</sup> discussed some of the problems that arise in applying electronic techniques to automatic telephone exchanges and described some solutions to these problems, and a later paper<sup>2</sup> enlarged on some of these problems and their solutions.

An essential component in any form of automatic telephone exchange is a switch that enables one circuit to be connected to any one of a number of other circuits. In a Strowger step-by-step exchange two such switches are the uniselector and the 100-outlet two-motion selector; they may be called 1-25 and 1-100 switches, the first figure being the number of wiper circuits and the second the number of bank circuits to which the wiper circuits have access. By multiplying the bank contacts of 10 uniselectors a 10-25 switch can be constructed in which 10 wiper circuits have access to 25 bank circuits. Similarly a number (N) of 100-outlet two-motion selectors can be combined by multiplying their bank contacts to form a N-100 switch.

The electro-mechanical switches referred to above use space-selection switching. Each bank circuit is connected to bank contacts which occupy fixed positions in space and a wiper circuit is connected to the bank circuit associated with the bank contacts on which the wiper rests, i.e., for a wiper circuit and a bank circuit to be connected together the associated wiper and bank contacts must be made to occupy the same space. In the switch used in the model time selection is used. Each "bank" circuit is associated with an individual instant in a recurrent time cycle and when a "wiper" circuit and a "bank" circuit occupy the same

instant in the recurrent time cycle those circuits are connected together. This form of transmission is called a time-division-multiplex (t.d.m.) transmission system.

#### TIME-DIVISION-MULTIPLEX TRANSMISSION

Fig. 1 shows the principles of time-division-multiplex transmission. T is a telephone transmitter, M is a pulse modulator, H a common transmission path or highway, G is a gate, D is a pulse demodulator and R is a telephone receiver. To the modulator M is connected a pulse generator which supplies a pulse train  $p_a$  to the modulator. Fig. 1(i) shows the pulse train, Fig. 1(ii) shows a typical signal that may be generated by transmitter T and applied to modulator

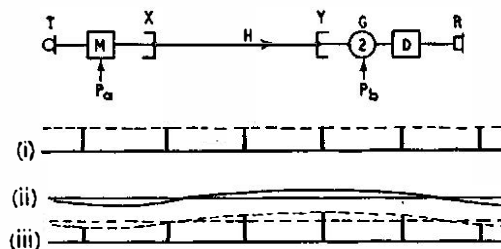

FIG. 1.—SKETCH ILLUSTRATING PRINCIPLES OF TIME-DIVISION-MULTIPLEX.

M, and Fig. 1(iii) shows the resultant amplitude-modulated pulse train that the modulator transmits to the common transmission path H. The gate, G, is controlled by a pulse generator which applies a pulse train  $p_b$  to it and the gate opens to connect the common transmission path H to the demodulator D only when a pulse from pulse train  $p_b$  occurs. If the two pulse trains,  $p_a$  and  $p_b$  are synchronous, the amplitude-modulated pulses on the common transmission path are transmitted through the gate to the demodulator D. In the demodulator the modulation on the pulses is extracted and is transmitted to the receiver R. The pulses forming the pulse train  $p_a$  use only a small fraction of the total time; for example, in the model exchange successive pulses in a pulse train are separated by 99 microseconds and each pulse lasts for about  $\frac{1}{2}$  microsecond. It is thus possible to parallel a large number of modulators and transmitters to the common transmission path H at X, each modulator having its own pulse generator

† Senior Executive Engineer, P.O. Research Station.

<sup>1</sup> "Introduction to Electronic Automatic Telephone Exchanges," T. H. Flowers, *P.O.E.E.J.*, Vol. 43, p. 61, Vol. 43, p. 177 and Vol. 44, p. 10.

<sup>2</sup> "Electronic Telephone Exchanges," T. H. Flowers, *Proc. I.E.E.*, Vol. 99, pt. I, No. 119, Sept., 1952.

and, if the pulse trains from all of the generators have the same pulse repetition frequency, the pulses on the common highway can be arranged to interlace with no mutual interference. In Fig. 2(a) are shown some of the 99 separate pulse trains used in the model, and in Fig. 2(b) are shown

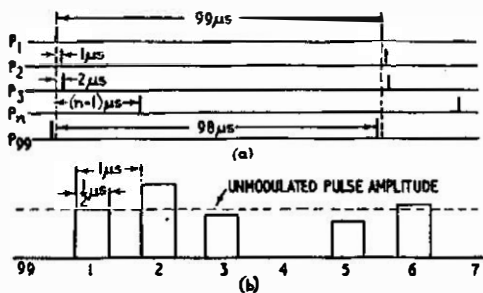

FIG. 2.—TYPICAL PULSE TRAINS.

some of the pulses that may occur during a period of 8 microseconds on the common transmission path: in Fig. 2(b), 1 is one of the pulses from pulse train  $p_1$ , 2 is one from pulse train  $p_2$  and so on; pulse 1 is unmodulated, 2 has a positive modulation, 3 has a negative modulation and during the time interval shown the pulses of pulse trains  $p_{99}$ ,  $p_4$  and  $p_7$  are absent.

Each pulse train can be used to carry a different audio-frequency signal and a t.d.m. transmission system may be used to provide a multi-channel long-distance transmission system over a common transmission path such as a cable pair or a radio channel. For such an application the audio-frequency ends of the circuits would be permanently associated in pairs, one circuit from a pair being taken from each end of the system. In a switch, the circuits connected to the two sides of the switch are variably connected together through the switch and to perform the switching operation the pulse trains are not associated permanently with the modulators and gates of the two sides of the switch. For example, if the circuits on one side of the switch are  $B_1, B_2, B_3 \dots B_m$  and the circuits on the other side are  $W_1, W_2, W_3 \dots W_n$ , circuit  $B_2$  may be connected to circuit  $W_7$  by connecting pulse train, say  $p_{17}$ , to the modulator of  $B_2$  and to the gate of  $W_7$ .

The examples shown so far provide unidirectional transmission because each demodulator has to include an amplifier in its circuit to compensate for the input signal power loss occasioned by transmitting the input signal over the highway only during the small fraction of time that a pulse is present. To provide a two-directional transmission system a second common transmission path is provided.

Fig. 3 shows such a two-directional t.d.m. transmission system. H1 and H2 are the two common transmission paths

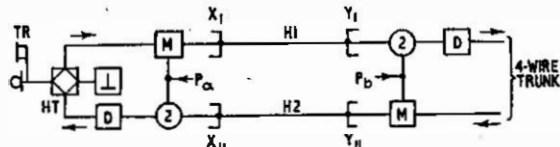

FIG. 3.—OUTLINE OF TWO-DIRECTIONAL T.D.M. TRANSMISSION SYSTEM.

and HT is a hybrid transformer which derives a 4-wire circuit from the 2-wire line to which the telephone transmitter and receiver are connected. Speech signals from the transmitter use the upper highway, H1, and speech signals to the receiver use the lower highway, H2. On the right of the diagram the 4-wire audio circuit is not shown as being connected to a hybrid transformer. As before, other similar circuits may be connected to the highways at X and Y and by synchronising a  $p_a$  pulse train with a  $p_b$  pulse train

the corresponding telephone transmitter and receiver and 4-wire trunk are connected together.

Some of the problems associated with t.d.m. transmission systems have been described by Flood and Tillman.<sup>3,4</sup>

### MODEL EXCHANGE

Fig. 4 shows one way of using a t.d.m. transmission system as a switch in a telephone exchange. The subscribers, two of whose lines,  $S_a$  and  $S_c$ , are shown, are connected through terminating sets, modulators, demodulators and

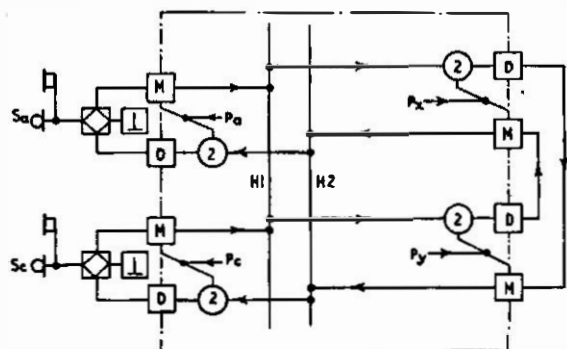

FIG. 4.—OUTLINE DIAGRAM OF T.D.M. TRANSMISSION SYSTEM USED AS A SWITCH IN TELEPHONE EXCHANGE.

gates to two common transmission paths H1 and H2. Each subscriber's line has its own individual pulse train and in the figure,  $S_a$  has an individual pulse train  $p_a$  and  $S_c$  an individual pulse train  $p_c$ . A number of "cord circuits" are also connected to the common transmission paths and one, C, is shown. To the modulators and gates at the two ends of the cord circuit may be connected any of the pulse trains that are associated with the subscribers' modulators and gates. In the diagram the pulse trains connected to the two ends of cord circuit C are  $p_x$  and  $p_y$ . The subscribers' lines and the cord circuits are audio-frequency circuits and pulse transmission is used only inside the chain-dot boundary shown in the figure. If subscribers  $S_a$  and  $S_c$  are to be connected together, pulse trains  $p_x$  and  $p_y$  may be made synchronous with pulse trains  $p_a$  and  $p_c$  respectively. Then subscriber  $S_a$  is connected to the upper end of the cord circuit using pulse train  $p_x$  and subscriber  $S_c$  is connected to the lower end of the cord circuit using pulse train  $p_y$ . As shown, the exchange does not provide the facilities that are essential for the operations of calling, setting up, ringing and metering and supervising a connection, and the modification of the equipment to provide these facilities is described below.

Fig. 5 shows the transmission equipment of the model 4-line exchange: in the figure the two directions of transmission have been shown by a single line. The exchange has four lines, a, b, c, and d, and two cord circuits; two simultaneous connections through the exchange may exist at a time. Within the chain-dot line, pulse transmission is used and audio-frequencies are employed outside that line.

The four lines have each their own pulse train supplies,  $p_a-p_d$ , and each line has the individual use of the highway H only during the time that one of its pulses is present. A single register-marker is connected to the highway through its own modulating, switching and demodulating equipment; its pulse supply  $p_1$  can be made synchronous with any one of the pulse trains  $p_a-p_d$  that are permanently

<sup>3</sup> "Crosstalk in Amplitude-Modulated Time-Division-Multiplex Systems," J. E. Flood and J. R. Tillman. *Proc. I.E.E.*, Vol. 98, Part III, No. 54, July, 1951.

<sup>4</sup> "Time-Division-Multiplex Systems," J. E. Flood, *Electronic Engineering* 1953, Vol. XXV, pp. 2, 58, 101, 146.



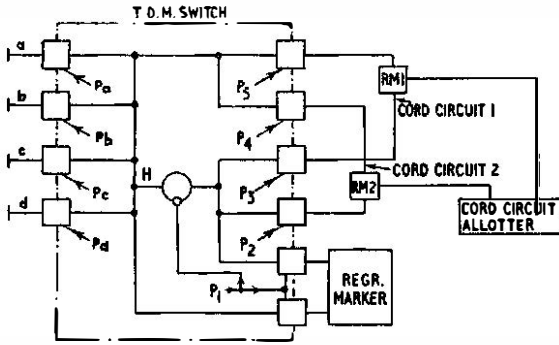

$p_a$  -  $p_d$  are fixed pulse trains;  $p_1$  -  $p_5$  are variable pulse trains and may be made synchronous with any of the fixed pulse trains. Pulse transmission within chain-dot lines; audio-frequency transmission outside these lines.

FIG. 5.—BASIC ARRANGEMENT OF TRANSMISSION EQUIPMENT IN 4-LINE MODEL EXCHANGE.

associated with the four lines. Two cord circuits are provided and each can be used to connect together a pair of lines, one end of the cord circuit being connected to the calling line and the other to the called line.

When one or more lines call, one of them (say "a") is connected to the register-marker by the register-marker's pulse train  $p_1$  being made synchronous with that of the one line ( $p_a$ ). The register-marker then transmits dial tone to the calling line and receives and stores the dialled number of the called line (say "c's" number). One of the cord circuits (say 2) is selected by the cord circuit allotter and one end is connected to the register-marker using the calling line's pulse train ( $p_2 = p_a$ ) and the other end is connected to the called line using the called line's pulse train ( $p_4 = p_c$ ). The register-marker prevents the calling line's pulses from reaching the cord circuit by operating the suppression gate circuit by the pulses  $p_1$ , and at this stage the calling line and the called line are connected to the register-marker but are not connected together. The register-marker sends a signal round the cord circuit to the called line to ring the bell and then drops out of circuit, leaving the calling line connected to one end of the cord circuit and the called line to the other end. A ringing and metering unit, RM2, in the cord circuit continues to control the ringing of the called line's bell and when the called line answers, the ringing and metering unit trips the ringing and sends a signal to the calling line to operate its meter. When the calling line clears, the pulse trains associated with the cord circuit cease and the connection is broken down.

#### Transmission System.

Fig. 6 shows the transmission equipment in more detail: each line is connected to a terminating unit which derives a 4-wire circuit from the 2-wire line; transmission inside the exchange is 4-wire. Each line has its own modulator, demodulator and gate, and has its own pulse supply. If line "a" calls, the pulse train  $p_1$  of the modulators and gates connected to the register-marker will be generated in synchronism with line "a's" individual pulse train,  $p_a$ , in a way to be described later. Line "a" then has a two-way transmission path set up to the "A" side of the register-marker over common transmission paths H1 and H2, using line "a's" pulse train,  $p_a$ . The register-marker sends dial tone to the calling line and the subscriber dials the called line's number. If "c" is the called line, the pulse train  $p_4$  or  $p_5$  (of the cord circuit selected by the cord circuit allotter) is made synchronous with the called line's pulse train,  $p_c$ , and the pulse train  $p_2$  or  $p_3$  associated with the same cord circuit is synchronised with the calling line's pulse train,  $p_a$ . The called line is then connected over common transmission paths H1 and H2 to one of the RM units, using the called line's pulse train,  $p_c$ , and through the RM unit and common transmission paths H3 and H4 to the "B" side of

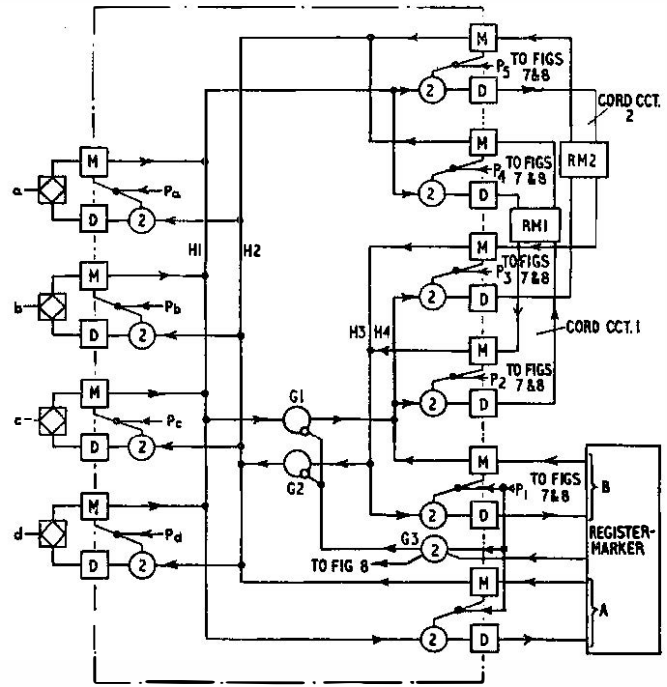

FIG. 6.—TRANSMISSION PATHS THROUGH ELECTRONIC AUTOMATIC TELEPHONE EXCHANGE (PULSE TRANSMISSION WITHIN CHAIN-DOT LINES; AUDIO-FREQUENCY TRANSMISSION OUTSIDE THESE LINES).

the register-marker using the calling subscriber's pulse train,  $p_a$ . A control signal from the register-marker opens gate G3 which connects pulse train  $p_1$  (synchronous with the calling line's pulse train  $p_a$ ) to gates G1 and G2 and prevents the transmission through them of the calling line's pulses, so preventing direct transmission from line "a" to the RM unit which would otherwise occur over the paths H1, G1, H4 and H3, G2, H2. This isolation of calling line from called line resembles the effect produced by the operation of the splitting key in an operator's cord circuit, and enables the register-marker to perform certain operating and checking operations before, by removing the control signal from gate G3, the calling and called lines are connected together through gates G1 and G2. The register-marker is then free to drop out, which it does by ceasing to supply the pulse train  $p_1$  (synchronous with the calling line's pulse train  $p_a$ ) to the two modulators and gates to which the register-marker is connected.

#### Connection of Calling Line to Register-Marker.

The modulator associated with each line is so constructed that the line's pulses appear on common transmission path H1 of Figs. 6 and 7 only when the receiver is off its rest and

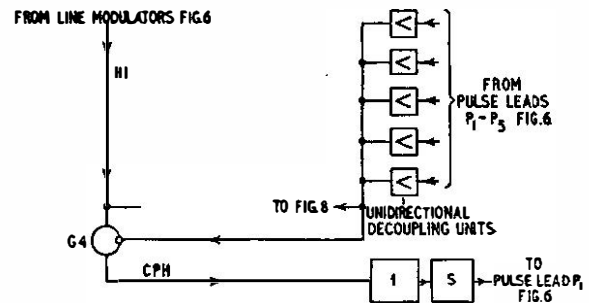

FIG. 7.—CONNECTION OF CALLING LINE TO REGISTER-MARKER.

line current is flowing. If any particular instrument is off its rest it will be because either (a) it is already forming part of another connection, or (b) it wishes to be connected to the register-marker. If the line whose receiver is off its rest

is already engaged in another connection a pulse train synchronous with the line's individual pulse train will be present on one of the leads  $p_1, p_2, p_3, p_4, p_5$ . All of these leads are connected to a gate G4, Fig. 7, in such a way as to prevent transmission through the gate of pulses synchronous with those on any of the leads. As the gate is connected to common path H1 only the pulses of calling but unanswered lines will be transmitted along calling pulse highway CPH to master selector 1.

It may happen that more than one line is calling for connection to the register-marker at the same time and there will then be more than one pulse train present on the calling pulse highway. The master selector isolates one pulse from the pulse trains applied to it and identifies the pulse train  $p_a, p_b, p_c$  or  $p_d$  from which it was taken. A signal is then sent from the master selector to its associated slave selector, S, and sets that slave selector to generate the identified pulse train. The pulse train so generated is applied over pulse lead  $p_1$  to the modulators and gates which, as already described, connect one of the calling lines to the register-marker. A hold signal from the register-marker controls the slave selector, which continues to generate the calling line's pulse train until the hold signal is removed.

As soon as the slave selector starts generating the pulse train of the identified calling line's pulse train, that pulse train appears on the lead connected to gate G4 and removes the pulse train from the calling pulse highway.

#### Marking of Called Line and Connection of Called Line to RM Unit and Register-Marker.

When the register-marker has received the called line's dialled number, a mark signal is put on the called line's marker lead  $M_a, M_b, M_c$  or  $M_d$  (Fig. 8). Should the called

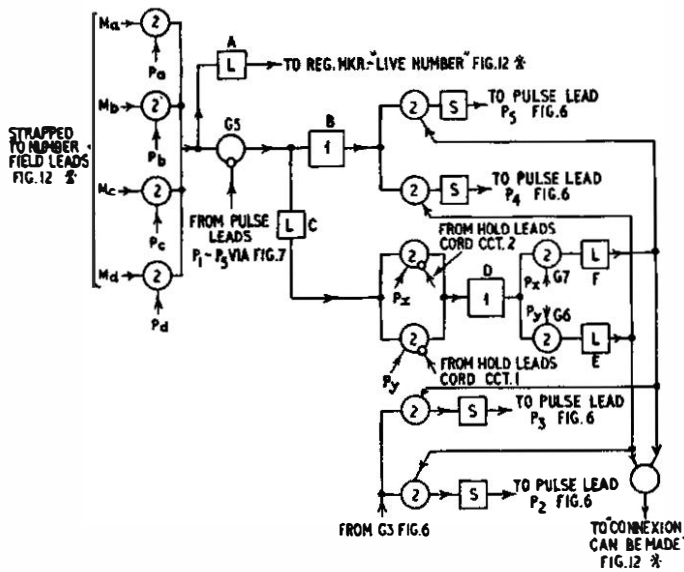

\*FIG. 12 will be included in Part 2 in the next issue.

FIG. 8.—MARKING OF CALLED LINE AND CONNECTION OF CALLED LINE TO RM UNIT AND REGISTER-MARKER.

number be that of a P.B.X., all the lines of the P.B.X. would have the same number and a mark signal would be applied to the marker leads of all of the lines. Each marker lead is connected to a gate to which is also connected the line's modulator and gate pulse lead (e.g.  $p_a$ ); the outputs from the gates are connected to gate G5. Thus, if a subscriber has two P.B.X. lines, say b and d, pulse trains  $p_b$  and  $p_d$  will appear at the input to gate G5 when that subscriber is called and marked. To that gate is also con-

nected a lead from pulse leads  $p_1-p_5$ . If the called line is engaged, its pulse train will be present on one of the pulse leads  $p_1-p_5$  and the pulses on the lead connecting those pulse leads to gate G5 close it to pulses that are synchronous with those present on leads  $p_1-p_5$ . Thus on the output lead from G5 will appear the pulse trains of the called lines that are not engaged. The input to G5 is applied to pulse-lengthener A whose output indicates that the called number is "live" and the output from G5 is connected to a master selector, B, which isolates and identifies one of the pulses and transmits the identity of the pulse train from which the pulse was isolated towards the two slave selectors, S, which are connected to the pulse leads  $p_4$  and  $p_5$ . Between the output from the master selector and each slave selector is a gate which is normally closed.

The output from gate G5 is also connected to a cord circuit allotter comprising a pulse lengthener C which produces on its output lead a D.C. signal only when a pulse or pulses are present at its input. The output from the lengthener is connected to two gates, one associated with each of the two RM units. To each gate is connected its own pulse supply ( $p_x$  and  $p_y$ ) and the gate is closed to the pulse supply so long as its RM unit is engaged. Thus when a called line is being marked pulses of the pulse trains of the free RM unit or units will appear on the common outlet from the two gates. These pulses enter the master selector D which isolates one pulse and transmits the isolated pulse to the two gates G6 and G7. One of these gates is opened by the pulse train  $p_x$  and the other by  $p_y$ ; thus on the output of only one of the gates will appear a pulse train which, after pulse lengthening in pulse-lengthener E or F opens the gate between the master selector B and the slave selector of the RM unit selected by the second master selector. The chosen slave selector is thereupon set by the first master selector B to generate the called line's pulses. The pulse-lengthener E or F, whichever is operated, also opens a gate which lets the calling line's pulse train identification be transmitted to the slave selector associated with the other end of the chosen cord circuit. One end of the cord circuit is now connected to the "B" side of the register, using the calling line's pulse train, and the other end of the same cord circuit is connected to the called line using the called line's pulse train.

The register-marker now transmits a ringing current control signal which applies a 17 c/s ringing current to the called subscriber's line. Some of that current is transmitted to the RM unit and there modulates a 400 c/s tone which is transmitted to the register-marker. The register-marker recognises the modulated tone and drops out of the connection, leaving the called line connected to the RM unit through gate circuits G1 and G2. The modulated tone passes through the switch to the calling line and acts as ringing tone. The RM unit takes over the task of transmitting a ringing current control signal (now with the usual ringing cadence) to the called line. When the called subscriber answers, his pulse train appears on common transmission path H1 and causes a continuous hold signal to be transmitted to the RM unit. On receipt of this signal the RM unit stops transmitting the ringing current control signal to the called line and sends a pulse of meter operating signal to the calling line to operate that line's meter.

The slave selectors of the cord circuit continue to generate the calling and called lines' pulse trains as long as the calling line is looped. When the calling subscriber clears, his forward hold signal disappears, the slave selectors cease generating the two pulse trains, the connection breaks down and the cord circuit becomes free and available for use in setting-up another connection.

(To be continued)

# A Telegraph Distortion Analyser

L. K. WHEELER, B.Sc.(Eng.), A.M.I.E.E.,  
and A. C. FROST, A.M.I.E.E.†

U.D.C. 621.317.74:621.394.813

This article describes an electronic start-stop telegraph distortion analyser. The analyser incorporates an accurate time-scale against which the late or early arrival of each characteristic instant (i.e. change from mark to space or vice versa) in a character signal is measured. An essential part of the analyser is a series of counting meters, each of which is arranged to record the number of characteristic instants of modulation occurring in a specific portion of the time-scale. The analyser is of high accuracy and enables the detailed performance of telegraph circuits to be observed; data in terms of signal distortion can readily be obtained.

## INTRODUCTION

VARIOUS instruments have been developed during the past 20 or so years for the measurement of telegraph distortion in various ways. The earliest instruments comprised continuous-running circular time-bases, either mechanical<sup>1</sup> or electrical,<sup>2</sup> the period of the time-base being equal to that of the unit element of the transmission, and the occurrence of the characteristic instants of modulation or restitution being indicated by the flashing of a rotating neon tube or a pulse of a cathode-ray beam producing a bright indicating spot on the screen of a cathode-ray tube. The application of the principle of the mechanical telegraph distortion measuring set was extended in the distortion and margin tester,<sup>3</sup> the time-base being lengthened to 7.5 units so that the characteristic instants of the individual elements within the character signal generated by a teleprinter transmitter could be separately displayed. This instrument could be used only when the transmission was continuous at the maximum character rate.

The development of true start-stop distortion measuring instruments followed considerably later; these have taken the form of cathode-ray oscilloscopes with either spiral,<sup>4,5</sup> zig-zag,<sup>6</sup> or ladder<sup>7</sup> time-bases, the displacement of the trace for each element of the character enabling the distortion of the individual characteristic instants of the signals to be observed.

The instruments mentioned so far have all been indicating instruments, but recording instruments<sup>8,9</sup> have also been produced. These are electro-mechanical in design and employ charts of paper, sensitive to an electrical discharge, to enable the occurrence of the characteristic instants to be recorded graphically. Another instrument which can be included in this group, but which is of a somewhat different nature, is the distortion monitor,<sup>10</sup> which measures the interval between successive instants of modulation and records the number of times that a predetermined minimum period is not attained.

There have also been other instruments designed to indicate, on dial meters, peak, mean or r.m.s. values of distortion, the last two types being semi-integrating instruments whose indicated readings refer to some rather indefinite period of observation.

By the use of the direct-indicating types of instrument, the observer may note the maxima occurring during the period of observation and also form some subjective estimate of the general value of distortion. The quasi-integrating type of instrument gives an averaged reading dependent upon the distortion distribution and the law of the instrument, but does not convey much information about the dispersion of the values, whilst a peak-indicating meter may give an inordinately high reading due to the isolated occurrence of a high value of distortion.

The recording instruments afford a very useful "memory" to the observer, who may examine and re-examine in detail the records obtained, but a considerable amount of tabulation and collation of the recorded observations is necessary before any statistical data can be derived.

The statistical study of telegraph distortion requires a

more elaborate instrument to facilitate the collection of data. An electro-mechanical instrument of this type<sup>11</sup> has been previously described but was not operable with start-stop signals. The circuit developments of recent years now afford the means of producing an electronic start-stop distortion analyser of a high accuracy, as will be described.

## PRINCIPLES OF THE ANALYSER

The fundamental requirements are an accurate time-scale, commencing at the reception of the first characteristic instant of a character signal and divided into suitable intervals of, say, 1 per cent. of a unit element, and a series of counting meters, each of which is sensitised in turn during a portion of the time-scale to record characteristic instants occurring during its allotted period.

In Fig. 1(a) is shown the waveform of a typical teleprinter

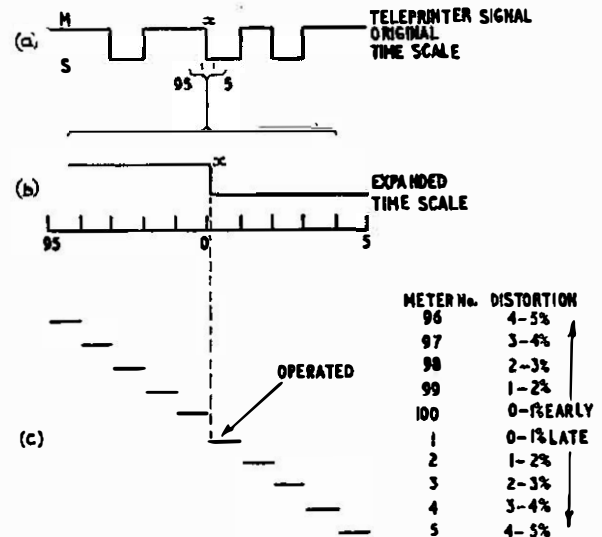

FIG. 1.—PRINCIPLE OF TELEGRAPH DISTORTION ANALYSER.

character-signal and in Fig. 1(b) one of the characteristic instants is shown against the proposed time-scale. The simplest conception of suitable apparatus is that the time-scale of 100 intervals is repeated for each theoretical signal element period in the character and that during each timing interval a different counting meter is connected to the circuit to detect the possible occurrence of a characteristic instant, as indicated in Fig. 1(c). This would be difficult to realise in practice because, to prevent false readings, the periods of connection of adjacent meters would need to be precisely contiguous, neither overlapping nor separated.

The basic design principles of the analyser are as follows. On reception of the start signal of a character, an electronic distributor with 100 outlets, and driven from a stable oscillator, is started. Metering circuits connected to selected outlets are primed when these outlets are energised. The succeeding signal modulations actuate a storage device which completes the energisation of the next meter circuit to be primed by the distributor, and the completion of the metering action causes the store to be reset to receive the next signal transition. Thus, the store is reset only when

† The authors are, respectively, Senior Executive Engineer and Executive Engineer, P.O. Research Station.

<sup>1</sup>For references, see end of article.

metering has occurred, no observation is omitted, and no two metering circuits are energised by the distributor at the same time; double counting is, therefore, impossible. The sequence of operation in this basic form is indicated in Fig. 2 where the meters (M1, etc.) are connected to

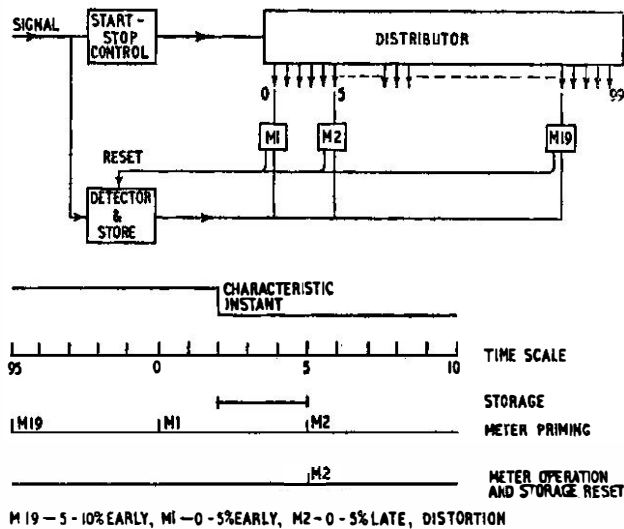

FIG. 2.—ELEMENTARY DIAGRAM OF ANALYSER, AND OPERATION TIMING.

record intervals of 5 per cent. distortion. The fundamental time cycle is repeated 6.5 times to cover the maximum distortion on all instants of modulation in the character, the apparatus then being automatically reset to await the next character.

#### OUTLINE OF CIRCUIT OPERATION

The main circuit elements of the telegraph distortion analyser can be divided into two groups as shown in Fig. 3; the right-hand group of circuits controls the start-stop operation of the analyser, whilst the left-hand group of circuits controls the metering of the incoming transitions. The time-intervals mentioned are those suitable for measurements of 50-baud teleprinter signals.

The method of operation of the start-stop group of circuits is as follows: when an incoming start-signal is received, the condition of the input trigger circuit changes over from mark to space and a negative impulse is applied over connection H to the control circuit. The latter circuit, which is a 135 mS pulse trigger, becomes operated and throughout the reception of the incoming character it applies a negative potential over connection I to the P and Q impulse generator. Under the control of this negative potential, V15 becomes cut off and the scale-of-two counter, V16, V17, is then free to operate under the control of the 10 kc/s pulse from the master oscillator. At each instant at which the scale-of-two counter steps, a negative impulse is applied either to connection P or to connection Q. Consequently, during the reception of the incoming character, the output of the P and Q impulse generator consists of two anti-phase sequences of 5 kc/s negative impulses.

The C1 drive circuit is an impulse-shaping and impedance-changing stage between the P and Q impulse generator and the C1 counter. Under the control of the P impulses, this drive circuit generates, on connection J, a sequence of positive impulses.

The C1 counter is a scale-of-ten ring counter formed from 10 gas-filled triodes, only one of which is conducting at a time. The conducting valve feeds a positive bias to the primer of the next valve in the circuit, which therefore strikes when the next positive drive impulse is received on connection J. In striking, this latter valve causes the pre-

vious valve to become extinguished. The C1 counter, therefore, steps at intervals of 0.2 mS and so completes a cycle of operations in 2 mS. In particular, once every 2 mS V29 conducts and feeds a positive potential over connection K to the C2 drive circuit where, after a short delay, it prepares V30 to respond to the next positive impulse to be received on connection J. Consequently, the C1 drive impulse which causes the C1 counter to step from V29 conducting to V20 conducting, also causes the C2 drive circuit to generate a drive impulse on connection L. It follows that the C2 counter steps at intervals of 2 mS and so completes a cycle of operations in 20 mS.

As the C1 counter completes 10 cycles whilst the C2 counter completes one cycle, the outlets of these two counters can be combined by resistor networks to form a 100-outlet distributor, each outlet of which is fully energised only when it is receiving a positive potential from both the C1 and C2 counters. The periodic time of this distributor is equal to the nominal duration of a signal element, and, therefore, each outlet corresponds to a particular 1 per cent. range of telegraph distortion, provided that, at the commencement of each character cycle, the C1 and C2 counters start to count from particular rest conditions.

At the end of the character cycle, the control circuit becomes reset and the negative potential on connection I is replaced by a positive one. Under the control of this positive potential, V15 conducts and prevents further operation of the P and Q impulse generator. The C1 and C2 counters, which receive no further drive impulses, are then reset to particular rest conditions by circuit elements which are not shown in Fig. 3.

The circuit elements which control the metering of a signal modulation operate in the following manner. The input trigger circuit acts as a signal shaper and generates a steep-fronted reproduction of the incoming signal. The functions of V1 and V2 are respectively to control the change-over of the circuit from mark to space and from space to mark; consequently the spacing sensitivity depends on the value of  $+v_1$ , the cathode potential of V1, whilst the marking sensitivity depends on the value of  $-v_2$ , the cathode potential of V2. Clearly, by suitable adjustment of these cathode potentials, the input trigger circuit can be made to have equal marking and spacing sensitivities. It then operates without introducing bias distortion.

When the polarity of the incoming signal changes from one condition to the other, two impulses, one positive and the other negative, are generated in the differentiating circuits of the input trigger circuit. The positive impulse has no effect, but the negative impulse passes through the associated rectifier and over connection B to operate the first storage circuit.

The function of the latter circuit, which is a synchronised pulse trigger, is to register the reception of an incoming transition and then to operate the second storage circuit at an instant at which the distributor is at rest. The amplitude of the Q impulses applied to the control grid of V5 is such that, after the first storage circuit has been operated for 0.15 mS, it is reset by the next Q impulse to occur. The negative impulse which is then generated on connection C causes the second storage circuit to become operated. The latter circuit stores the fact that an incoming transition has been received until this information can be recorded by one of the meter circuits.

The telegraph distortion analyser contains 100 resistor networks formed from the 10 connections M (from the C1 counter) and the 10 connections N (from the C2 counter). For one 0.2 mS period during each cycle of the distributor, each resistor network receives a high positive potential both on its connection M and on its connection N; its output potential is then also a high positive one, but at all other



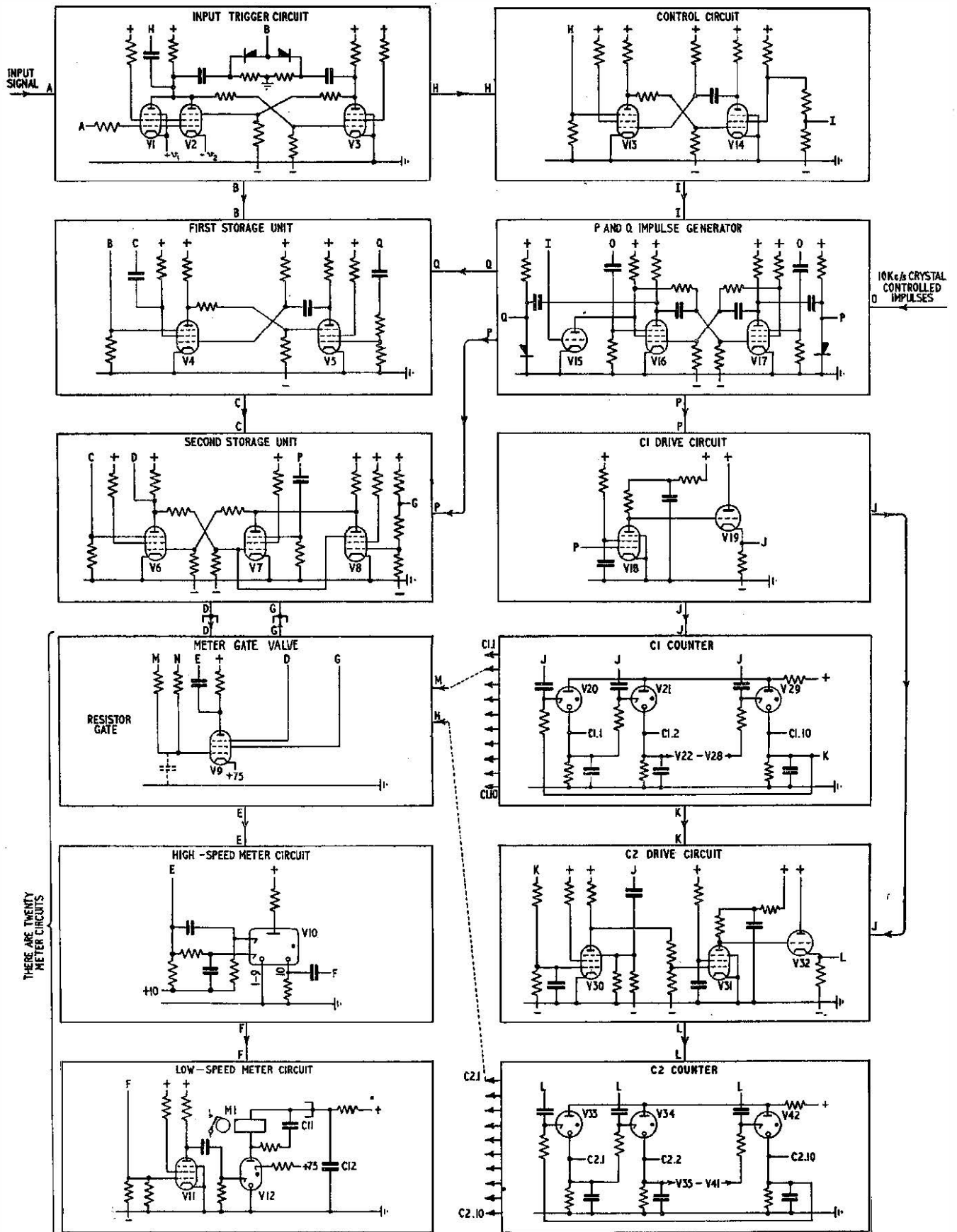

FIG. 3.—SIMPLIFIED CIRCUIT OF DISTORTION ANALYSER.

times during the distributor cycle, its output potential has a much lower value.

The ranges of distortion which are to be associated with the 20 individual meter circuits, are selected by connecting the control grid of each meter gate valve to an appropriate resistor network. Therefore, during a cycle of the distributor, each meter gate valve has a positive bias on its control grid for a particular 0.2 mS period.

When, as a result of an incoming transition, the second storage circuit becomes operated, it applies a positive bias to the suppressor grids of all 20 meter gate valves. If one of these valves is already receiving a positive bias on its control grid from its associated resistor network, the process of metering takes place immediately, but if all the meter gate valves are cut off by their control grids, this process is delayed until the next meter circuit is primed. Once every 0.2 mS during the period of waiting, V7 becomes cut off by the negative P impulse which it receives on its suppressor grid, but as V8 remains conducting the second storage circuit does not become reset. When the distributor steps to a condition which causes the control grid of one of the meter gate valves (say V9) to receive a positive bias, this valve conducts. The negative impulse which is then generated by the anode circuit of V9 is applied by connection E to its associated high-speed meter circuit. V9 in conducting draws screen grid current over connection G from the common screen grid circuit and the potential of V8 control grid changes from positive to negative. V8 becomes cut off but, as V7 remains conducting, the condition of the second storage circuit does not immediately change. However, at the next distributor stepping instant, the suppressor grid of V7 receives another negative impulse and, as the anode of V8 is already cut off, the second storage circuit becomes reset.

The negative impulse which is applied by connection E to the high-speed meter circuit causes the Dekatron<sup>13</sup> V10 to step. When the glow of V10 steps from the ninth cathode to the tenth cathode, a positive impulse is applied over connection F to the low-speed meter circuit. V11 conducts and applies a negative impulse to the inner primer of the Neotron V12. An arc is then set up between the inner and outer primers of V12 and the resulting ionisation causes an anode-to-cathode arc to strike. This main arc (in the order of 100A) rapidly charges the capacitor C11 from the energy stored in C12. When after a very short period the arc in V12 becomes extinguished, C11 discharges through the electromechanical counter M1, which operates and registers 10 operations of the high-speed meter circuit.

There are other circuit features of the analyser which have been omitted from the simplified diagram of Fig. 3.

A guard circuit is provided to prevent the initial modulation at the commencement of the start-element from being metered, and if a specially detailed analysis is to be made, this same circuit can be used to restrict the metering to record only those signal modulations occurring between a chosen adjacent pair of elements, e.g., the characteristic instant separating the second and the third elements when these are of opposite polarity.

The recording of either mark-to-space or space-to-mark transitions may be inhibited at will, a facility which enables the effect of bias to be accurately identified.

The distortion analyser, like all start-stop telegraph apparatus, operates correctly only when it is started by genuine incoming start signals; if it responds to short spurious start signals,<sup>12</sup> it gives a false idea of the actual distortion. The analyser therefore contains a circuit which restores the control circuit to rest when the start signal is found to be shorter than a predetermined time (this can be 2, 4, 6, 8 or 10 mS; the number of incoming false start signals can be recorded). Even with this short start signal rejection

facility, it is still possible for the longer circuit disturbances to cause the analyser to become out-of-phase with respect to the incoming signal; this condition can be indicated indirectly on a monitoring teleprinter with the aid of a signal regenerator controlled by the distributor of the analyser, a very useful feature for supporting the reliability of the observations.

During the mathematical processes which are required to interpret the test results, the individual counts have to be expressed as percentages of the total count, a process which is considerably simplified if the total count is an integral power of 10. The distortion analyser therefore contains a circuit which prevents further analysis after  $10^2$ ,  $10^3$ ,  $10^4$  or  $10^5$  operations have been recorded.

When the object of investigation is the performance of transmission circuits alone, a source of signals generated with negligible distortion is required, so an electronic signal generator controlled from the same, or a similar, accurate high-stability oscillator which provides the basic timing of the analyser, has been designed. The signals available are any teleprinter character repeated continuously, reversals, or mixed text read from a 5-unit perforated tape.

Although the distortion analyser is primarily a start-stop device, it can be operated synchronously, either with or without automatic phase correction. The preferred method of using it for the measurement of synchronous distortion is to set up a looped transmission system with the signal generator controlled by the distributor of the analyser, the phase of the transmitted signals being adjusted by a manual phase control.

#### EXAMPLES OF MEASUREMENTS

At the end of a distortion measurement, the analyser provides the following type of information:—

- Of the characteristic instants of modulation analysed—
- 3 were between 5 per cent. and 4 per cent. early.
- 14 were between 4 per cent. and 3 per cent. early.
- .....
- .....
- .....
- 13 were between 5 per cent. and 6 per cent. late.
- 1 was between 6 per cent. and 7 per cent. late.

A convenient way of displaying the results, which facilitates the interpretation of this information, is to draw a curve on graph paper which has an arithmetical probability scale<sup>14</sup> as shown in Fig. 4. This example shows the result of

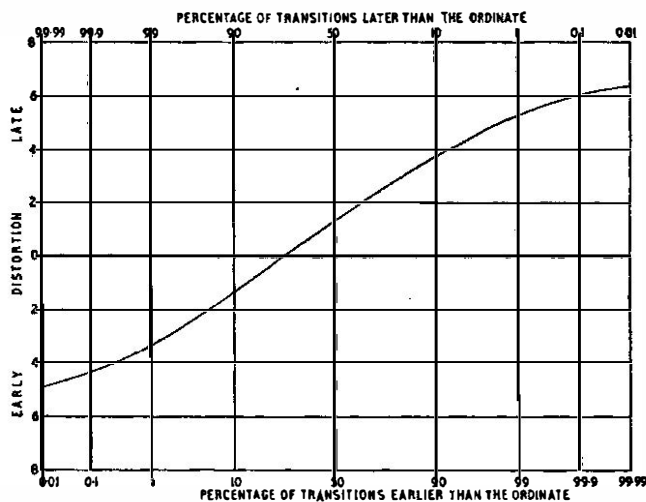

FIG. 4.—DISTORTION MEASURED ON A TELEPRINTER TRANSMITTER.

measuring the transmitter distortion of a typical teleprinter. The curve shows, for example, that only 1 per cent. of the characteristic instants are earlier than  $3\frac{1}{2}$  per cent. early;

1 per cent. are later than 5 per cent. late; and  $6\frac{1}{2}$  per cent. distortion is exceeded only once in 10,000 instances. This curve, like most of the distortion curves, has a straight middle section—the graph of a normal distribution would be a straight line<sup>14</sup>—and flattened end sections which suggest that the distortion has maximum early and late values (instead of infinite values as would be given by a completely normal, i.e., random, distribution).

Fig. 5 shows the results of three sets of measurements

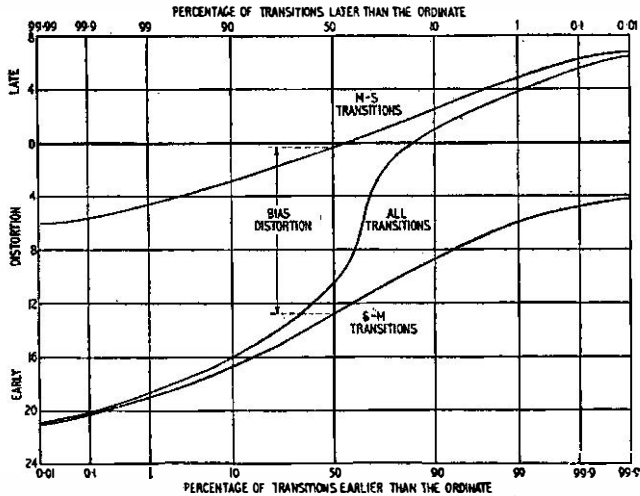

FIG. 5.—DISTORTION MEASURED ON A MULTI-LINK V.F. TELEGRAPH CIRCUIT.

made on a certain biased circuit. The curves showing the distortion of the mark-to-space transitions and of the space-to-mark transitions are similar in shape to that of the previous graph, but the curve representing the aggregate of both types of transition is quite different. At the end sections it is almost asymptotic to the other two curves because, for example, whilst probably none of the mark-to-space transition has more than 12 per cent. early distortion, 60 per cent. of the space-to-mark transitions have more than this value. The very noticeable inflexion of the aggregate curve is a characteristic feature produced by bias distortion. As the curve of the mark-to-space distortion has (a) its mean value quite close to 0 per cent. (because start-stop distortion is measured relative to the commencement of the start element, which is a mark-to-space transition) and (b) a lower "maximum" distortion than the curve of the space-to-mark distortion, it is possible to obtain a measure of both the bias distortion and the "maximum" distortion by merely measuring the distortion of the space-to-mark transitions.

## CONCLUSIONS

The analyser which has been described has a high order of accuracy, the distortion observations being automatically segregated into 20 groups, the limits of which may be varied at will in steps of 1 per cent. distortion, the error or uncertainty of the group limits being less than  $\frac{1}{2}$  per cent. at any point in the scale.

The field of application in the study of telegraph performance is very wide, e.g., investigation of the quality of transmitters and transmission circuits, both under controlled operating conditions and in actual service.

Hitherto, the detailed performance of telegraph circuits has been known only as a result of laborious observations or spot checks; little data, in terms of signal distortion, is available on the day-to-day performance of circuits between the times of periodical maintenance adjustments and it is hoped to remedy this deficiency by the collection of field data with the aid of the analyser. The information so obtained should be particularly valuable as an aid to planning of telegraph networks and circuit provision.

It is hoped to publish the results of some of these investigations at a later date.

## References.

- <sup>1</sup> A. Jipp and O. Römer. "Verzerrungsmesser für Telegraphie," *T.F.T.*, May 1932.
- <sup>2</sup> V. J. Terry and C. H. W. Brookes-Smith. "A Telegraph Distortion Measuring Set," *Elec. Comm.*, Vol. 12, No. 1, April 1933.
- <sup>3</sup> E. H. Jolley. "Determining the Transmission Efficiency of Telegraph Circuits," *P.O.E.E.J.*, Vol. 26, Pt. 1, April 1933.
- <sup>4</sup> W. T. Rea. "A Cathode-ray Telegraph Distortion Measuring Set," *Bell Lab. Rec.*, Vol. 25, p. 150, April 1947.
- <sup>5</sup> G. T. Dain. "An Improved T.D.M.S.," *A.T.E. Journal*, Vol. 9, No. 1, January 1953.
- <sup>6</sup> P. Pellé. "La Distorsion Télégraphique et sa Mesure," *Annales des Telecom.*, Vol. 1, No. 12, December 1946.
- <sup>7</sup> L. K. Wheeler and R. S. Tissington. "An Electronic Distortion Measuring Set for Start-Stop Telegraph Signals," *P.O.E.E.J.*, Vol. 32, Pt. 1, April 1950.
- <sup>8</sup> G. L. Erickson. "A Telegraph Signal Analyser," *Electrical Engng.*, Vol. 67, p. 218, March 1948.
- <sup>9</sup> Review—"Die Nachrichtentechnik auf der Technischen Messe Hannover," *E.T.Z.*, Vol. 74, No. 12, p. 372, June 1953.
- <sup>10</sup> R. O. Carter and L. K. Wheeler. "Some Applications of Electronic Methods to Telegraph Apparatus," *I.P.O.E.E.*, Printed Paper No. 199.
- <sup>11</sup> R. B. Shanck, F. A. Cowan, S. I. Cory. "Recent Developments in the Measurement of Telegraph Transmission," *B.S.T.J.*, Vol. 18, p. 143, January 1939.
- <sup>12</sup> R. O. Carter, L. K. Wheeler and A. C. Frost. "An Electronic Regenerative Repeater for  $7\frac{1}{2}$  Unit Start-Stop Telegraph Signals," *P.O.E.E.J.*, Vol. 41, Pt. 4, January 1949.
- <sup>13</sup> R. C. Bacon and J. R. Pollard. "The Dekatron," *Electronic Engng.*, Vol. 22, p. 173, 1950.
- <sup>14</sup> J. F. Doust and H. J. Josephs. "A Simple Introduction to the use of Statistics in Telecommunications Engineering," *P.O.E.E.J.*, Vol. 34, Pt. 1, April 1941.

## Book Review

"D.C. Generators and Motors." J. E. Macfarlane, B.Sc., M.I.E.E., A.M.I.Mech.E. Sir Isaac Pitman & Sons, Ltd. 99 pp. 38 ill. 8s. 6d.

This little book is one of the publishers' elementary electrical engineering practice series.

It is intended "to provide a simple introduction to these important machines for those who are not yet in a position to study the more advanced text books on D.C. machine design. . . ."

The preface claims that the subject matter is suitable for engineering students studying for the Ordinary National Certificates.

The treatment of fundamental principles is very superficial. The student reading Lenz's Law explained in two lines

on page 1 will find little to help him in the diagram to which he is referred. The explanation of generator action on page 4 is very confused. The thoughtful student will also want to know why field pole pieces are laminated (page 10) and why some of the laminations are then short-circuited by tapping them for fixing bolts. He is left to guess the plane in which the poles are laminated. Although a knowledge of hysteresis is assumed, it is thought necessary to explain the simple solenoid in detail.

The calculation of the ampere turns required in the air gap is explained but the remainder of the magnetic circuit is not treated. Losses in machines, other than the armature copper loss, are dismissed in a few words.

The installation of machines, parallel operation, speed control and maintenance are dealt with. There are 38 illustrations, most of which are well produced and useful.

A. E. P.

# Facilities for Experimental Work in the Engineering Department

W. WEST, O.B.E., B.A., M.I.E.E.†

U.D.C. 654.001.5

All Branches of the Engineer-in-Chief's Office concerned in experimental and development work now have their own laboratories and workshops which are decentralised from the main Research Station at Dollis Hill. This article gives a brief account of the facilities which have been provided for such work and outlines the range of investigations and developments undertaken.

## Introduction.

FACILITIES for experimental work by the Engineering Department are not confined to the laboratories of the Research Branch (R) and the Radio Experimental and Development Branch (WE) at the Research Station at Dollis Hill; some other Branches of the Engineer-in-Chief's Office carry out experimental work in connection with their particular problems. Since 1946 some encouragement has been given to appropriate Branches to create or expand, to a limited extent, their own facilities for experimental work. Arrangements were made for regular co-ordination of such activities by setting up, in 1946, the Research and Development Sub-Committee (of the Engineer-in-Chief's Co-ordination and Development Committee) under the chairmanship of the Controller of Research. The Sub-Committee consists of the heads of all the Branches concerned and it is kept regularly informed of all the subjects of experimental work currently in hand by each Branch.

It is not the purpose of this article to discuss the relative merits of centralising or diffusing experimental effort, nor to describe the laboratories or the work done at the centralised Research Station, which has been the subject of articles published from time to time.<sup>1</sup> The object is, instead, to assemble together some brief accounts of other, and perhaps less well known, facilities for carrying out experimental work by the Engineering Department in the normal course of its activities.

## Radio Branches.

The Radio Planning and Provision Branch (WP) has more than others the need and the facilities for doing experimental work at service installations, i.e., at radio stations and the radio-telephony terminal. The rapid development of the art and of the services, and the need in many cases for providing only very few (often expensive) items of similar equipment at any one time, lead to experimental development being carried out on the items provided for service. This applies particularly to the higher-powered radio transmitters and their associated aerial systems and it includes design of circuits, valve cooling systems and H.T. power supplies, and of devices for ensuring the safety of operating personnel in the presence of high voltages. Major advances have been made in improving the linearity of Class-B high-frequency radio transmitters of 4-40 kW power rating as a necessary part of the application of the multichannel telephone and telegraph techniques to the Overseas Radio Services.

Radio propagation conditions, particularly on long-distance services, are subject to wide and irregular variations so that extensive measurements and tests under field conditions are needed. It is often necessary to carry out tests of operational radio links to assess the performance of different types of equipment under varying propagation conditions, and also to endeavour to identify the form of propagation which is predominant. In such cases the tests

are usually made at the operational sending or receiving station or at the radio-telephony terminal, using equipment available at the station, supplemented, as required, by apparatus sent from Headquarters.

During the development of the equipment which has been installed in the new radio-telephony terminal at Brent Building,<sup>2</sup> the designs of items which are essential to the feature of automatic control of the circuits were carried out using a small space, fitted as a laboratory, in the old terminal at Faraday Building.

Some small, non-operational, radio stations are used exclusively for experimental and development work. The radio-measuring station at Banbury (Fig. 1), now controlled by WP

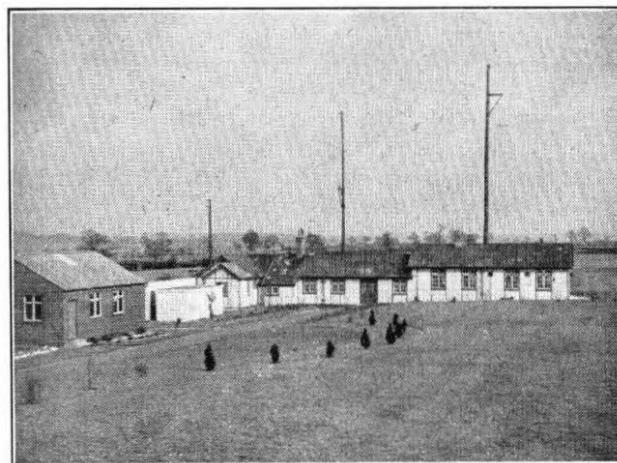

FIG. 1.—PART OF BANBURY RADIO-MEASURING STATION.

Branch, has a site of 8 acres in open country, relatively free from man-made interference. The accommodation here includes three wooden and five brick or concrete buildings with a total laboratory space of nearly 5,000 sq. ft. It is equipped with frequency and field-strength measuring equipment, direction-finding equipment and apparatus for recording the distribution of signals in any particular part of the radio-frequency spectrum and for displaying the energy spectra of particular emissions. The main use of this station is for obtaining data required for the planning of Post Office radio services and for International conferences dealing with the usage of the radio spectrum. The station normally covers the frequency range from 15 to 30,000 kc/s.

Radio laboratories at Wembley, Mill Hill, Backwell and Castleton are, in effect, out-stations of WE Branch at Dollis Hill, by whom they are staffed and controlled. Though acquired originally for different reasons, all now serve the essential function of providing additional accommodation to that at Dollis Hill.

About 1936 a rather sudden expansion in the activities of Radio Branch occurred which necessitated seeking extra accommodation. The projects for the London-Birmingham coaxial cable and the M.U.S.A. high-frequency receiving station at Cooling Marshes may be cited as contributory. The need was eventually met (in 1938) by

† Staff Engineer, Post Office Research Station.

<sup>1</sup> For example:—*P.O.E.E.J.*, Vol. 24, p. 6 and Vol. 45, p. 143. *J.I.E.E.*, Vol. 75, p. 133.

*Nature*, Vol. 162, p. 51 and Vol. 168, p. 1022.

*Bel! Laboratory Record*, Vol. 25, p. 277.

<sup>2</sup> *P.O.E.E.J.*, Vol. 44, p. 25.



renovating and adapting part of the old "Palace of Engineering" which had been built for the Empire Exhibition at Wembley. Now, about 4,900 sq. ft. of this space is occupied by WE Branch staff on work mostly concerned with designing and constructing radio-frequency testing and measuring equipment. The premises at Mill Hill were acquired during the war; they are used as a model-shop for small-scale productions of quartz crystal elements, and as such hardly fall within the scope of this article.

With the prospect of using very high frequency (5 metres) radio links in the telephone network of this country came the need for an experimental radio link for testing out systems and apparatus. Two sites on high ground, facing each other across the Bristol Channel, were obtained for this purpose in 1933, at Backwell in Somerset and Castleton in Monmouth. During the war, and in accordance with the policy of dispersing some staff from London, the sites were occupied on a permanent basis in temporary accommodation which is being (has been at Castleton) replaced by permanent buildings. At Backwell about 2,500 sq. ft. is available, occupied by a staff of about 28 engaged mostly on the design and calibration of apparatus for measuring radio interference, and on measurements of field strengths from various emissions. New permanent buildings at Castleton provide a total of about 5,000 sq. ft. of accommodation space where the development of very high frequency systems is the main occupation of a staff of about 30.

#### *Local Lines and Wire Broadcasting Branch.*

Any development of wire broadcasting by the Post Office would need to be closely linked with the development of the local telephone network, and the Local Lines and Wire Broadcasting Branch (LLB), formed in 1947, took over accommodation which had been used by the former Wire Broadcasting Branch (1936 to 1941) in the Palace of Engineering at Wembley. Of this accommodation, 1,400 sq. ft. is allocated for laboratory use and 350 sq. ft. for a workshop. The laboratory equipment includes a variety of plant for testing components, assemblies and systems at audio and video frequencies and at carrier frequencies up to 10 Mc/s. The workshop contains, in addition to some 50 sq. ft. of bench space equipped for small assembly and fitting, sufficient tools to enable experimental chassis and prototype amplifiers and receivers, etc., to be readily produced, and more precise machine work is frequently undertaken.

For the Olympic Games (1948) special cables, including  $\frac{3}{8}$ -in. coaxial tubes, were provided, linking the Stadium with Broadcasting House. A short extension of spare coaxial tubes and audio pairs in this cable has enabled LLB Branch to obtain a television programme circuit and three sound programme circuits from Broadcasting House to the laboratories. The sound circuits have been equalised to 20 kc/s.

Work in the laboratories is divided between three groups, one dealing with studies of audio and television wire broadcasting systems, another with development of carrier wire broadcasting over the local and junction telephone network and the third with matters directly related to government control of wire broadcasting. This last item includes giving technical advice to the Administrative Departments and the testing, at manufacturers' works and in the field, of sound and television wire broadcasting systems to check that such systems conform to the terms of the licences under which they are operated. This same group also deals with certain special line facilities required by wire broadcasting companies, which are not fully covered by the work of any other Branch and which usually involve some special measurement or development work.

The carrier wire broadcasting group has developed an 8-channel wire broadcasting system which could use the telephone network for distribution of programmes to telephone subscribers and others, without disturbing the normal use of the network for two-way telephone conversations. This system is similar to a 5-channel system in use in Switzerland and the 3-channel systems used in Germany. Latterly a single-channel system, with many special features to ensure continuity of service, has been developed and tried in the field on a large scale for use in connection with Civil Defence.

The main function of the audio and television group is to study systems of wire broadcasting. As an incidental to these studies the group has developed a compact cassette type of music amplifier using miniature valves and having a better performance and occupying a much smaller space than music amplifiers previously used by the Post Office.

From time to time the local line planning groups have occasion to make transmission performance measurements on special assemblies of telephone apparatus and lines. Equipment provided by R Branch for this purpose is available in the laboratory.

All the accommodation is overcrowded and efforts have been made during the past four years to find a means of relieving congestion. The ground floor below the laboratory is vacant and it is expected that work will shortly begin on its adaptation to meet the needs of Branches in the E.-in-C.'s Office using the first floor. Some of this extra space will be allocated to LLB Branch.

#### *Transmission and Main Lines Branch.*

The laboratory of the Transmission and Main Lines Branch (LM) was established in January 1948 in part of the basement of Castle House, Aldersgate Street, originally with a staff of one Senior Executive Engineer, one Assistant Engineer and one Technical Officer; for many years previously improvised facilities had been found to be necessary. It was moved to occupy about 1,900 sq. ft. for laboratory and workshop on the mezzanine floor in Alder House during the following April, and although it has not been possible to obtain more laboratory accommodation the staff has increased to one Senior Executive Engineer, three Executive Engineers, six Assistant Engineers and 16 Technical Officers and Technicians. Formal investigation case records, commenced in 1948, have now reached a total of 330, and 218 laboratory reports have been issued.

The primary objective of the laboratory is to provide, with minimum formality, maximum assistance and facilities for all groups of LM Branch in designs and developments requiring experimental work and electrical measurements. The type of work carried out in it may be classified as follows:—

- (a) Design and development of transmission equipment for main line use, especially non-standard items such as apparatus for testing and monitoring and carrier equipment for submarine cables. Similar work on equipment for outside broadcast video circuits has recently been undertaken.
- (b) Construction of prototype models or of small quantities of urgently required or experimental units.
- (c) Investigation under controlled conditions of difficulties found in service use of transmission systems.
- (d) Testing of sample or prototype models of new types of equipment developed by contractors. This has included life testing, under simulated working conditions, of modern types of electronic valves introduced into new designs.
- (e) Maintenance, repair and calibration of the large amount of testing equipment held by the Branch for testing carrier and coaxial systems during installation.

The specialised laboratory apparatus includes a frequency standard and decade frequency synthesiser; insertion-loss measuring and calibrating equipment for the audio, carrier and coaxial frequency ranges; an H.F. phase meter for obtaining Nyquist diagrams of feed-back amplifiers; a valve test bay with which life-testing panels are incorporated; some electrical bridges permanently set up and components to enable others to be set up as required. For subjective tests of programme equipment, a rediffusion feed is available for sound with a high-quality loudspeaker and power amplifier; for television there is a standard video signal, and transmissions from Alexandra Palace can be picked up by an aerial on the roof of Alder House.

Not all of the experimental work carried out in the laboratory is actually done by the staff of the laboratory. It is frequently desirable for officers in other groups in the Branch to make use of the facilities for their own work, but such use comes under the general supervision of officers in charge in the laboratory and reports are prepared in the same way as for work wholly carried out by laboratory staff.

#### *Telephone Development and Maintenance Branch.*

The Circuit Laboratory of the Telephone Development and Maintenance Branch (Tp) was established in 1924 in King Edward Building, E.C.1, and articles describing its purpose and organisation and its growth in size and importance have been published.<sup>3</sup> The Laboratory has recently been transferred to Armour House, and this accommodation is described separately in this issue of the Journal. The Laboratory (Fig. 2) now employs approximately 100

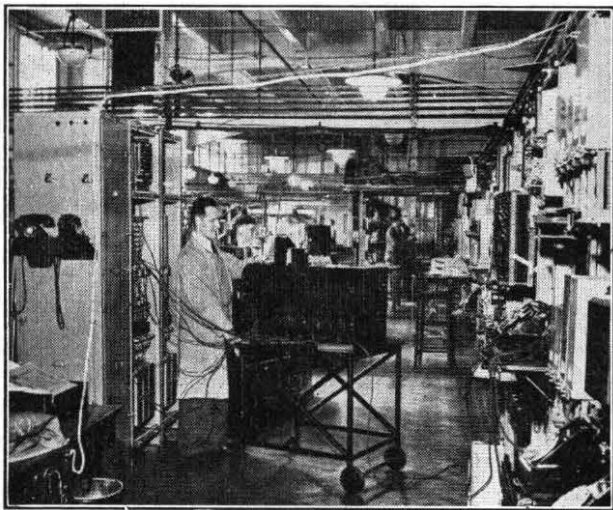

FIG. 2.—CIRCUIT INVESTIGATION ON A U.A.X.12 IN THE TP BRANCH CIRCUIT LABORATORY, IN KING EDWARD BUILDING.

Technical Officers, Technicians and Youths, and 20 Supervising Engineering staff and Clerical staff.

Tests on circuits and apparatus are carried out under the appropriate adverse conditions, as required by those responsible for development work or concerned with maintenance problems, and factual and critical reports on performance are issued. It has always been a feature of the work of the Circuit Laboratory that its tests are carried out in the closest possible collaboration with the development or maintenance engineers concerned. This ensures that those interested are kept informed of the results as the tests proceed, in advance of the issue of test reports. Furthermore, although the Laboratory is not primarily a development organisation, and a factual report is all that may be required, the Laboratory is often able to assist in

development work or in the solution of maintenance problems. The results of tests often indicate the lines on which development might proceed or modifications be introduced.

Approximately 200 Laboratory Investigation Cases are completed each year. They vary in size from tests on a single component to complete functional tests of a system involving many relay sets. The majority of cases, almost all of which are concerned with telephone switching problems, can be classified under the following headings:—

*Circuit Investigations.*—The general functional tests carried out on circuits and circuit elements include relay sets and selector circuits of all types as well as tests on complete signalling systems. In addition a great variety of miscellaneous circuits are tested by the Laboratory. At present the majority of circuits tested employ electro-mechanical principles but circuits using electronic techniques are of course also tested and are appearing with increasing frequency.

*Impulsing.*—In addition to general circuit tests, a considerable proportion of development investigations involve measurement of the impulsing performance of relays and systems. On the maintenance side also, routine test impulsing conditions require constant investigation.

*Mechanical Life Tests.*—Accelerated life tests to investigate mechanical wear are normally in progress on 3,000- and 600-type relays, both of standard design and with various modifications, and on relays of many other types. Samples of Type 2 and Type 3 uniselectors from various contractors, and motor-driven uniselectors, are also under life test, and many similar tests have been carried out on various aspects of the performance of 2,000-type selectors.

*Mechanical Investigations other than Life Tests.*—Many investigations into mechanical performance, apart from life tests, are carried out. These include such matters as contact bounce (on relays, mechanically operated spring sets of selectors, or wipers), the dimensional check of components and the hardness of materials. In these investigations optical and photographic methods play an important part and frequent use is also made of high-speed cinematography. The Laboratory was indeed one of the first organisations of its kind to make regular use of high-speed cinematography as a testing technique<sup>4</sup> and a substantial library of films taken with camera speeds of up to 3,000 frames per second is now held.

#### *Telegraph Branch.*

The Telegraph Branch (Tg) for many years had a small Experimental Room, first in the Central Telegraph Office, London, then, after the C.T.O. fire in 1940, in Alder House. After the war, space was found on the 3rd Floor of 100 Aldersgate Street, only a short distance from the office of the Branch in Alder House. The floor area of the laboratory is approximately 3,500 sq. ft., including messing and locker accommodation for the 14 minor staff who work there full time and an office for the two Assistant Engineers in charge and visiting officers. The laboratory is attached to one Development Group for the purpose of administration, but all the Development Groups have working facilities in the laboratory and supervise their own case work. The control of case records is centralised in one group.

The work carried out in the laboratory falls into four main groups, as follows, and the laboratory is divided accordingly:—

- (a) Automatic Teleprinter Switching Systems.
- (b) Manual Teleprinter Switching Systems.
- (c) Telegraph machines.
- (d) Telegraph Transmission, Power and Facsimile equipment.

<sup>3</sup> P.O.E.E.J., Vol. 18, p. 177 and Vol. 29, p. 53.

<sup>4</sup> P.O.E.E.J., Vol. 31, p. 293.

One room, for durability testing of teleprinters and other instruments, is enclosed and noise-proofed to avoid disturbance to the rest of the laboratory. The workshop section is fitted with a 4-in. precision lathe, watchmaker's lathe, pillar drilling machines, pedestal grinder and a hardness-testing machine. A dark room is used for photographic work in connection with facsimile equipment and the Duddell oscillograph.

An installation of 4-channel and 18-channel M.C.V.F. telegraph equipment, and interruption recording equipment, is used for making observations of the stability of working M.C.V.F. systems terminating in London. Equipments for switching systems include models of the teleprinter automatic switching system, the phonogram automatic distribution system, the international and inland manual telex systems and automatic sub-centre equipment for the telex services. The laboratory models include switching centre equipment, position equipment, and the associated routine testers together with auxiliary equipment. These models were built in the course of development of the various systems and are used for experimental investigations of points arising from field experience.

The type of work done in the laboratory includes the construction and wiring of equipment to enable tests to be made of new circuit designs. For example, the teleprinter automatic switching system for the public service was developed by Tg Branch. The development entailed, in addition to the design of the switching centre equipment, the production of a range of ancillary equipment, such as routine testers for use at switching centres and out-stations, test tables for line testing, observation desks for use by operating staffs, test desks and other miscellaneous items.

The design and development of teleprinters and automatic transmitters are carried out by contractors; Tg Branch specifies the facilities required and the technical performance to be met. Maintenance and adjustment techniques have to be evolved for each type of machine and continuous efforts are made to improve the performance of machines in the light of field experience. A recent example is the design of a modification to a standard start/stop automatic transmitter to improve the action of the transmitter tongue and to give step-by-step tape feed. This modification, which is now undergoing field trials, shows promise of giving considerable improvement in performance. Development work on transmission, power and facsimile equipment results mainly from the examination and approval of contractors' designs and investigations relating to maintenance of such equipment in the field. A considerable amount of work has been done in connection with measurement of telegraph distortion and determination of transmission standards. Transmission tests to determine the suitability and stability of various types of line for M.C.V.F. telegraph working are also made in collaboration with LM Branch.

#### *Power Branch.*

For a large proportion of the work of Power Branch (P), i.e., in connection with substations, switchgear, engines, heating, ventilation, lifts, conveyors and kitchen equipment, the needs of the Post Office can be met most economically by normal commercial designs of good quality, and little development work for specific Post Office needs is required.

The large quantity of lighting fittings in use in Post Office buildings, the special requirements of public offices, sorting offices, switchrooms and apparatus rooms and the advantages of standardisation, led the Department many years ago to develop its own range of such lighting fittings and a laboratory for the measurement of light has long been needed. A small room which can be used for this purpose has been fitted up in Leith House with apparatus for measuring the output and distribution of light. Here

the new standard fitting for fluorescent lighting was developed. In addition this laboratory is used for the development of battery charging and voltage control systems for telecommunications; detail investigations of rectifier characteristics and of battery design problems are also undertaken. The general examination of power plant matters is, however, best carried out in the field.

A large basement room, about 100 ft. by 100 ft., at Mount Pleasant was made available in 1948 for experimental work by P Branch on mechanical aids to postal operations. A portion of this room is partitioned off and equipped with machine tools for a workshop (Fig. 3) in which about 13

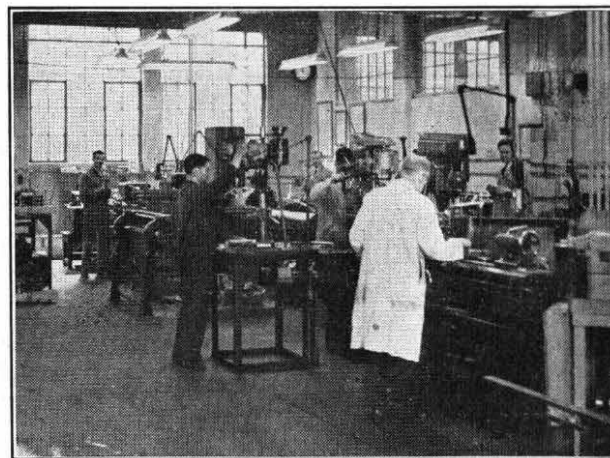

FIG. 3.—THE WORKSHOP, P BRANCH LABORATORY AT MOUNT PLEASANT.

men are regularly employed. This accommodation is particularly well situated since the bulk of the development work is associated with the handling of letters and parcels, and testing with live mail is essential at a very early stage of developments of this kind. The sorting office at Mount Pleasant can meet all needs in this respect and testing can be carried out readily and without delaying postal traffic. In addition facilities are available for testing various forms of conveyor and also mechanical aids such as postal order, parcel label and stamp issuing machines. The laboratory has also developed burglar alarms and a controller for a parcel sorting machine, and has made tests and models of mechanical aids for the cable ships. The workshop itself is also a laboratory for testing machine tools as it is used for solving, by practical tests, problems that arise in connection with the equipment of Post Office workshops in the Regions.

#### *External Plant and Protection Branch.*

When the External Plant and Protection Branch (Cn) returned to London from Harrogate towards the end of 1945, a small room in the basement of Leith House was obtained for use as a workshop. There was no minor staff employed and the work was confined to simple trials (e.g., testing Award Case suggestions) not involving elaborate equipment.

With the advent of polythene cable and the new types and sizes of coaxial cables, it became evident that the facilities would have to be greatly increased to provide for the development of suitable jointing techniques. To this end, and to cope with the increase in work on tools and mechanical aids, the workshop was reorganised. By the end of 1948, minor staff, having external construction and workshop experience, had been recruited from the L.T.R., and a 3½-in. screw-cutting lathe and other subsidiary machines installed.

The scope of the work continued to widen and more



accommodation and equipment were soon required. In 1949, the workshop was moved to larger and better premises at 96, Aldersgate Street, where it is now located, and includes a milling machine and oxy-acetylene welding equipment (Fig. 4). While the normal day-to-day work



FIG. 4.—CN BRANCH LABORATORY.

continues largely as "workshop" activity, a substantial number of quite complex tests and experiments are carried out from time to time involving the use of special equipment and, as a result, the "workshop" has graduated to a "laboratory".

Some of the projects on which work has been done in the laboratory are the cathodic protection of underground cables, pressurised cables (involving much experiment to find a satisfactory method of sealing cables) and also the development of equipment for testing and fault-localisation. The present minor-staff complement is seven Technical Officers and Technicians II.

#### *Subscribers' Apparatus and Miscellaneous Services Branch.*

A small laboratory and workshop was first established by the Subscribers' Apparatus and Miscellaneous Services Branch (S) during the wartime evacuation of the Branch to Harrogate. It was subsequently transferred to Castle House, Aldersgate Street, and now occupies about 350 sq. ft. of floor space and employs five Technical Officers and

Technicians II. Facilities are available, including a lathe, drilling and bending machines and coil-winding machine, for the construction of prototype equipment and components. An increasing range of testing equipment is available for carrying out electrical tests on completed items and for making life tests. This testing equipment includes an A.C. bridge, two oscilloscopes, variable-frequency oscillators and a comprehensive range of measuring instruments.

The laboratory facilities are particularly useful for the immediate testing of apparatus submitted by the public (i.e., attachments for recording telephone conversations, etc.), for testing new circuits and examining unusual faults. Several new testers have been developed including an experimental dial speed and ratio tester which makes use of Dekatrons to count the oscillations of a stabilised 1,000 c/s oscillator under the control of the test dial.

#### *Test and Inspection Branch.*

The nature of the duties of the Test and Inspection Branch (I) involve the provision of a comprehensive range of measuring facilities covering electrical, mechanical, chemical and physical tests. Some, or all, of such tests are applied, as a routine matter, to apparatus, cables and materials. No special provision of facilities has been involved on those occasions when the Branch has ventured into the experimental field and modest excursions have been a fairly regular feature of the technical activities of the Branch over a good many years. The chemical laboratories, in particular, have undertaken a number of minor investigations; many of these have been instigated by other Branches or Departments but some, of course, have been directed towards the improvement of I Branch's own routine test methods. Experiments have fairly frequently been put in hand to facilitate the development of new electrical test gear to be applied to the testing of cables or apparatus or line plant. A series of I Branch reports has recently been commenced to place on record the experimental work of the Branch. Facilities for experimental work done by I Branch exist at Studd Street, London, and Fordrough Lane, Birmingham.

#### *Acknowledgments.*

For compiling this article, information and help were sought from the Branches named and were generously given.

## **Book Review**

"Television Engineering," Vol. I. S. W. Amos, B.Sc.(Hons.), A.M.I.E.E. and D. C. Birkinshaw, M.B.E., M.A., M.I.E.E. Iliffe. 292 pp. 188 ill. 30s.

This book is the first of a series of B.B.C. Engineering Training Manuals dealing with television. Although primarily intended for the Corporation's own staff, it will be of considerable general appeal to all engineers interested in television and of particular value to those engaged in any form of television work. None are better qualified to write such a book than engineers of the B.B.C. who have been concerned with television from its earliest beginnings, and it contains a good deal of inside information that has not previously been gathered together in one place. Vol. I is divided into three sections dealing with fundamentals, camera tubes, and optics.

The first section shows how a picture may be represented by an electric waveform and gives details of the standard used in this country. This is fairly old ground, of course, but is nevertheless important, for these fundamental aspects of the subject must be mastered before proceeding to more advanced studies.

The second section deals with camera tubes and how, in practice, the camera converts a picture into an electric signal. In addition to the more common high- and low-velocity photo-emissive types of camera tubes, some of the newer photo-conductive types are described. The latter are now being produced in very small sizes and are likely to be of considerable value in industrial applications of television.

The final section deals with optics, both of the light and electron variety. The very thorough treatment starts with the principles of reflection and refraction, and leads through curved mirrors to lenses and, in particular, to lenses for television cameras. Included is an all too brief mention of that most intriguing device, the zoom lens, which enables the shot to change from distant to close-up without any movement of the camera. The chapter on electron-optics shows the analogy between electron beams and light, and how the equivalent of a lens for an electron beam is produced by a magnetic or electric field.

The book is a most valuable contribution to the literature on television and future volumes in the series will be awaited with interest.

T. K.



# Trunk Testing at Zone Centre Exchanges

L. A. MISSEN†

U.D.C. 621.395.365:621.395.5

Due to an alteration to the control arrangements for the testing of trunk circuits and to meet the requirements of trunk mechanisation, considerable modification to trunk test racks has been necessary. This article describes the changes in detail and discusses the reasons which led to their adoption.

## INTRODUCTION

**H**ITHERTO, transmission faults on trunk circuits have been dealt with primarily at terminal repeater stations known as the "transmission controls" for the circuits concerned. With this method of working fault reports were passed from the traffic division to "trunk test," and, if the fault proved to be in the line equipment, from trunk test to transmission control. If one of these steps is eliminated and the number of separate sections of staff concerned is reduced, the circulation of a fault report is expedited with a corresponding reduction in ineffective time. It is with the object of reducing this "lost circuit time" that trunk test has assumed the duties of transmission control, and only when there are practical difficulties in exercising this control will the local repeater station staff deal with the fault report. For example, with carrier or coaxial circuits the operational frequency range is 12 kc/s upwards and outside the scope of the exchange testing equipment. For this reason, and because of the difficulty of gaining access to suitable testing points, trunk test will be responsible only for the location of faults in the audio ends of this class of circuit, any faults beyond these points being passed to the carrier or coaxial group control for precise location and clearance of the fault. This still represents a saving over the old scheme, however, as trunk test would have passed a transmission fault to the transmission control.

While the location of the transmission control was under consideration, changes were taking place in the method of dealing with trunk traffic, and it was necessary to consider what effect the introduction of trunk mechanisation would have on trunk testing. Additional testing equipment has been developed for this purpose and is described in the section on trunk mechanisation requirements.

## GENERAL

When consideration was given to the transmission testing equipment for transmission control work at trunk test centres, it was apparent that something more than the single-frequency equipment used at zone and group centres was required for the main trunk routes. As the provision of multi-frequency testing equipment at some three hundred group centres would not be an economic proposition in view of the equipment already held in the repeater stations, it was decided that the main provisions of the scheme could be realised if zone centres only were equipped with multi-frequency testing equipment. The racks used for testing normal trunk circuits will be provided with apparatus suitable for testing over the audio band between 300 c/s and 3,400 c/s; other racks will be equipped for testing music circuits and making special measurements.

The quantities involved preclude the use of conventional type repeater station testing equipment, both from the point of view of the cost and of accommodation, and instead a range of ten single-frequency oscillators has been produced to supplement the existing apparatus.

Under the present single-frequency transmission testing arrangements voltmeter No. 36A is used for both D.C. and A.C. measurements. A.C. measurements are made by using a two-valve negative feedback amplifier (Panel, Test TL 2647) between the signal to be measured and the voltmeter, the resulting output from the amplifier being

rectified and applied to the voltmeter. The same principle is used in the transmission measuring set, Tester RP 790. An advantage of this method of A.C. measurement is that the amplifiers can be multiplied, and a suite of twelve test racks served adequately by four amplifiers. This arrangement has therefore been retained for use on trunk test under transmission control conditions.

A similar system of multiplying is used for the single-frequency oscillator, but under this scheme the number of oscillators required to serve a suite of 12 test racks when 10 frequencies are required is 40. Each oscillator has four outputs and the total number of outlets is 160. Multiplying this number of outlets and providing guard lamps to prevent overplugging becomes unnecessarily complicated. The alternative of increasing the number of oscillator outputs to 12 so that multiplying can be avoided was investigated, and it was found possible to do this and, at the same time, to improve the design. The new oscillator is known as the Oscillator No. 32.

## TRUNK TEST RACKS

Some indication of the appearance of a trunk test rack may be gained from an earlier article.<sup>1</sup> The standard rack now has four panels instead of three but the general appearance of the rack is substantially unchanged.

Although the basic design of the trunk test rack has not been altered, provision for the following additional equipment (described in later paragraphs) has been made:—

### *Associated with Testing Rack,*

- (i) A range of 10 single-frequency oscillators (300 c/s to 3,400 c/s) with a Yaxley-type selecting switch.
- (ii) Variable attenuator 0-30 db. (1 db. steps).
- (iii) Lines to trunk test selector, test selector and test final selector.
- (iv) Cathode-ray oscilloscopes.
- (v) Test terminating relay sets.

### *Associated with the Record Rack,*

- (i) Supervisory lamps in the busy circuits.
- (ii) Mass-busy keys for use in the event of coaxial breakdown.
- (iii) Holding circuits for fault tracing from cordless switchboards.

### *Other apparatus,*

- (i) Self-answering test relay sets.

The opportunity has been taken to collect together as many as possible of the miscellaneous answering and speaking circuits, and to provide similar facilities by a single group of multi-purpose circuits.

## MODIFICATIONS TO MEET TRANSMISSION CONTROL REQUIREMENTS

### *Test Cord Circuit.*

The modifications to the test cord circuit are outlined in Fig. 1, from which it will be seen that the outputs from the Oscillators No. 32 are connected to the banks of a rotary switch and any of the ten frequencies may be

† Assistant Engineer, Telephone Development and Maintenance Branch, E.-in-C.'s Office.

<sup>1</sup> P.O.E.E.J., Vol. 26, p. 53.

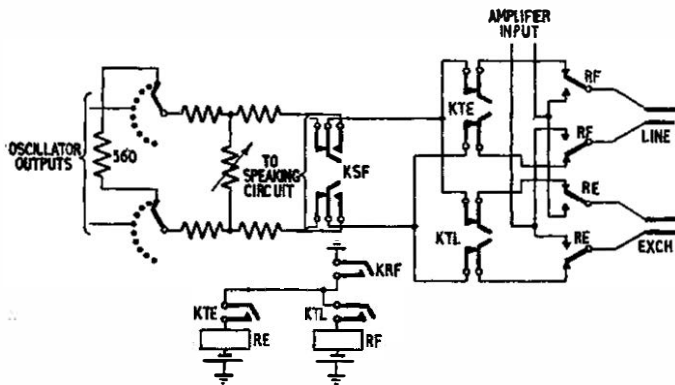

FIG. 1.—OUTLINE OF MODIFICATIONS TO TEST CORD CIRCUIT.

selected as required. A twenty-four point Yaxley-type switch is used and the oscillator outputs are connected to alternate contacts. This arrangement has been adopted to reduce intermodulation between adjacent frequencies, the unused contacts being connected to earth. An additional precaution is the use of screened cable for the connections between the oscillators and the Yaxley switch banks.

Between the oscillator outputs and the test cord a variable attenuator is fitted and the oscillator output level, nominally 0 db. (reference 1 mW in 600 ohms) may be attenuated to any desired level between 1 and 30 db. in steps of 1 db. To facilitate the operation of the equipment when co-operating with a distant exchange, a single key is used to switch from "send" (KSF) to "receive" (KRF) or vice versa; the mid-position of this key connects the test cord speaking circuit.

#### Oscillator No. 32.

A complete range of 10 oscillators covers the frequencies 300, 500, 800, 1,000, 1,600, 2,000, 2,400, 2,600, 3,000 and 3,400 c/s. For each frequency, the tuned circuit consists of an inductor shunted by a fixed capacitor, the required frequency being determined by the value of the capacitor used. Apart from this the oscillators are identical.

One great advantage of fixed frequency oscillators over variable frequency oscillators is that no readjustment to correct the output level is necessary when passing from one frequency to another, and a frequency run over the band can be made speedily and accurately.

A simplified circuit of the oscillator is shown in Fig. 2. It is a valve oscillator of the Hartley type with its tuned circuit connected between the grid of the valve and earth. Oscillation is sustained by feedback between the cathode

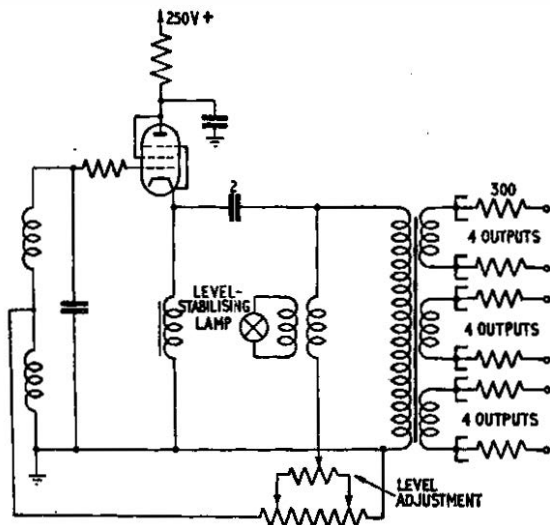

FIG. 2.—SIMPLIFIED CIRCUIT OF OSCILLATOR No. 32.

and a tapping on the resonant circuit inductance. The amplitude of the feedback is kept constant by three selected 6V lamps connected in series across the secondary of a transformer, with its primary in the feedback circuit. The resistance/current characteristic of the lamp filaments is such that as the lamp current increases, the resistance rises, and this increase is reflected back into the primary circuit. The increase in signal amplitude is thus curbed with increasing effect as the lamp current rises. The reverse effect is experienced if the signal amplitude falls, and in this manner the oscillator is self-stabilising.

The lamp transformer has three impedance ratios, namely 44:1, 51:1 and 60:1, to provide for a wider tolerance in lamp resistance, and a tapped resistor in series with the transformer primary is used for the adjustment of the output level. The oscillator output is taken from the cathode of the valve via an output transformer. The secondary of the output transformer has three windings each with four outputs. The design is such that the variation of signal level at any single outlet when the remaining outlets are changed from open to closed circuit does not exceed 0.075 db. The oscillator has an excellent long-term stability and routine testing of the output level is required not more frequently than at six-monthly intervals. During this time the R.M.S. level variation from 1 mW in 600 ohms should not exceed 0.2 db.

A mains supply unit has been designed to serve a maximum of eleven oscillators, an additional 1,600 c/s oscillator being supplied for testing independently of the test cord circuit.

#### MODIFICATIONS TO MEET TRUNK MECHANISATION REQUIREMENTS

##### Circuit Busying.

The busying circuit has undergone modification to make it suitable for association with selector level circuits serving mechanised trunk switching equipment. Before trunk mechanisation the operator had direct access to the trunk circuits from the switchboard. Under trunk mechanisation, however, many of the trunk circuits are accessible only via the selector levels so that the operator will be unaware of the number of the circuit used and, in the event of a fault it will be necessary to hold the connection so that the circuits used may be traced. When the circuit has been traced it may be necessary to busy and hold it for testing purposes. These functions are performed automatically by the busying circuit after operation of the key on the record rack appropriate to the particular trunk circuit. A supervisory lamp associated with this key, flashes until the operator at the distant exchange releases the originating circuit. When the operator releases the circuit, the busying circuit will engage the trunk circuit, but allow the equipment between the originating exchange and the trunk exchange to release. When this has occurred, the supervisory lamp flashing signal changes to a steady glow. This feature shows at a glance how many circuits are artificially busy and enables the fault situation to be kept under constant surveillance.

The busying supervisory lamps appear only on the record rack; they are not necessary on the test positions, because the test selector equipment, like the busy circuit, is designed to wait on an engaged circuit and busy the circuit when it becomes free.

As there is one busying equipment for each trunk circuit it is desirable to limit the amount of apparatus per circuit. Fig. 3 shows how the required facilities have been obtained with a single relay.

Normally the key contacts are open. When the key is operated an earth is connected to relay BR and if the associated relay set is disengaged, battery on the BT wire will operate BR which locks to battery at BR1 until the

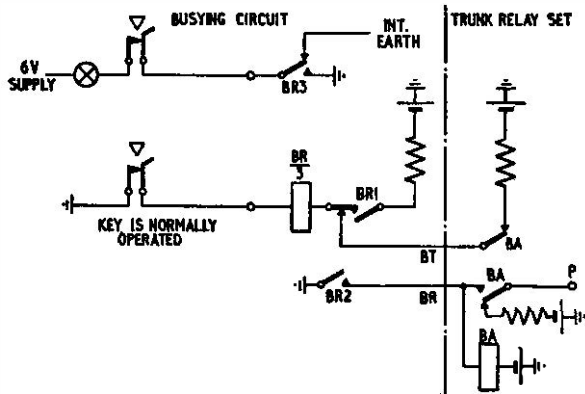

FIG. 3.—THE NEW TRUNK-BUSYING CIRCUIT.

key is restored; contacts BR2 and BR3 busy the relay set and light the engaged lamp respectively. If the circuit is already engaged, relay BR cannot operate and the engaged lamp flashes to the interrupted earth. When the circuit becomes disengaged the connection of battery on the BT wire causes relay BR to operate and apply the conditions already described.

Under coaxial breakdown conditions, the number of circuits to be busied may be considerable, and speedy busying is desirable to take the faulty circuits out of service. The individual busy keys are, in these circumstances, wired in groups of up to 12 corresponding with the coaxial groups served, and taken to a mass busying key on the record rack.

#### Access to Trunk Circuits for Testing.

All the existing methods of access for testing are retained and in addition, access to selector level circuits will be possible by the use of trunk test selectors. By plugging the test cord into a "lines to test selector circuit" jack on the test rack and dialling a 4-digit code, the test selector train is stepped to the trunk circuit corresponding to this code and access to the trunk circuit via the trunk signalling relay set is obtained. By signalling over the circuit it is possible to make test calls into the distant apparatus or alternatively to a transmission test number relay set at the distant exchange. (See Fig. 4.)

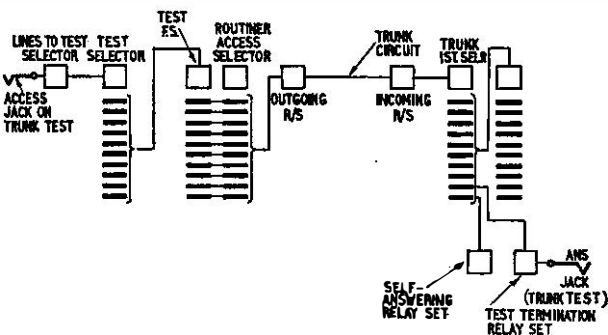

FIG. 4.—BLOCK SCHEMATIC DIAGRAM OF ACCESS TO TRUNK CIRCUIT AND TESTING FACILITIES AT DISTANT EXCHANGE.

One of the difficulties to be overcome in making transmission measurements through relay sets under working conditions is that of preventing D.C. from flowing in the measuring equipment. For example, consider a call over V.F. equipment: the transmission path must be kept open by maintaining "subscriber answer" conditions at the incoming relay set and this requires D.C. conditions. The transmission measuring equipment must also be connected to this circuit in order to make a measurement, but D.C. must be prevented from flowing through the measuring equipment. An obvious solution is to divide the answering

test termination relay set into two sections by fitting capacitors, one section to return a D.C. condition and the other to connect with the measuring equipment. The choice of capacitor value is important since the impedance of capacitors varies with frequency, but  $10\ \mu\text{F}$  capacitors offer a reasonable compromise over the range of frequencies concerned.

The "lines to test selector" circuits are also provided with a transmission bridge for the reasons which have already been described and similar precautions have been necessary to provide a constant-loss transmission test circuit. The use of a test selector and test final selector provide a multiple of 10,000 code numbers, but in view of the limitation of trunk units to 3,000 O/G trunk circuits, the test selector has been arranged so that after dialling the code digits, single impulses may be dialled to obtain a second or possibly a third choice of test final selector. This provides an alternative outlet if the first of the test final selectors is engaged. If the required trunk circuit is engaged the test final selector waits on the circuit until it becomes free and then automatically busies it. Indication of the circuit condition is given by supervisory lamps on the trunk test rack.

The banks of the test final selectors are in the same multiple as those of the access equipment for a trunk circuit routiner, and the test final selectors are mounted beside the access selectors at the rear of the routiner rack.

#### Test Termination Relay Set.

A test termination relay set is provided for use with the test selector equipment, so as to enable a transmission measurement to be made through the trunk line inclusive of the terminating relay sets. Formerly only the line between the 2-wire terminations was measured.

Test termination relay sets, which will be provided at all zone centres, terminate on the trunk test rack and are arranged to act as answering circuits besides providing test facilities. On receipt of a call from a distant exchange testing officer the calling supervisory lamps light. The trunk testing officer at the incoming end of the circuit answering with his test cord, can either continue to use the test cord, in which case the whole of the testing facilities of the test rack are available, or alternatively, if required by the calling testing officer, he can operate a key associated with the answering circuit and return tone at 1,600 c/s. Access to the test termination relay set will be obtained by dialling a 2- or 3-digit code. By restricting the number of switching stages, the possibility of transmission loss between the trunk terminating relay set and the test termination relay set is reduced.

### MISCELLANEOUS EQUIPMENT

#### Self-Answering Relay Set.

In dealing with faults of any description time is inevitably lost when co-operation from a distant exchange is required.

It is not difficult to design a relay set which, when seized, will return tone at a predetermined level for as long as is required. Thus a testing officer at exchange A dialling a test number on exchange B, can gain access to such a relay set and use the returned tone to make a transmission measurement over the circuit. However, with such an arrangement the transmission loss would be measured only in the RETURN direction. In the GO direction, although the loss might be as much as 12 db., all that would be known was that dialling over the circuit was possible. A way of measuring the loss in each direction is to make the return of tone dependent on the receipt of tone, at the correct level, and clearly the relay set must respond only within narrow limits if the test is to be of any value.

A circuit to meet these conditions is of the valve-triggering type in which a small increment in the received signal produces a current large enough to operate a relay.

After some experimental work a cathode-coupled circuit of the Schmidt type was developed which has proved to be extremely sensitive and when operated from a stabilised power supply is capable of detecting a level change of 0.1 db. An outline diagram is given in Fig. 5.

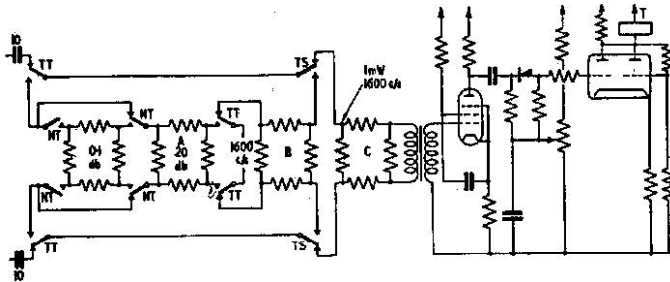

FIG. 5.—SIMPLIFIED CIRCUIT OF SELF-ANSWERING RELAY SET.

A circuit of this class will of course respond to any signal of sufficient level and duration to trigger the valve, and a filter has been developed to precede the trigger circuit so as to prohibit response except to the testing frequency. However, filters will not be fitted unless experience shows that signals other than the testing frequency are of sufficient duration to cause the triggering circuit to operate. Measurements will be made using a tone level into the trigger circuit of -20 db. The object of using a low signal level is to assist in detecting dry contact faults which would otherwise break down and disappear under the influence of a stronger signal.

A testing officer wishing to make a transmission measurement over a circuit will pick up the circuit via the test cord circuit and the test selector train, and by dialling the test number, seize a test (self-answering) relay set at the distant exchange. A short period of N.U. tone will indicate that the relay set has been seized and that sending may commence. The testing officer will know from his record card what the transmission loss of the circuit (including the terminating relay sets) should be and will set the attenuator in the test cord circuit to -20 db., less the value on the record card, e.g. if the nominal loss at 1,600 c/s (the testing frequency) is -3 db. the attenuator is set at -17 db. Triggering of the relay set is indicated by the return of 1,600 c/s test tone for a period of 6 to 12 sec., during which the RETURN measurement is made. A further 6 to 12 sec. of tone may be obtained by sending a period of tone to re-trigger the relay set at the distant exchange.

To avoid premature triggering due to surges in the relay set, tone must be connected for a period of 1.25 sec. After triggering, tone is not returned from the relay set until the triggering tone has been disconnected for 0.75 to 1.5 sec. This gives the testing officer time to prepare to make a measurement.

Referring to Fig. 5 it will be seen that an incoming signal passes through the TT and TS contacts to the trigger circuit input transformer. To prevent triggering due to surges in the circuit a short-circuit (not shown in Fig. 5) is maintained across the primary of the transformer until just before the 1,600 c/s tone is connected.

The operation of relay T (due to the operation of the trigger circuit), after a suitable interval, causes relay TS to operate and 1,600 c/s tone is connected to line via attenuator B. The loss due to B will be adjusted so that the average overall loss over a line as measured at the outgoing end of the trunk circuit will be between -10 db. and -20 db.

Incorporated in the relay set is a means of checking that triggering occurs at the correct input. Thus, when the TT (test trigger) contacts are closed the 1,600 c/s supply in the

relay set is passed through attenuator A into the triggering circuit and if the triggering circuit is correctly adjusted relay T should operate and the "triggered" supervisory lamp should light. When the NT (not trigger) contacts are operated an additional 0.1 db. loss is inserted into the tone circuit and in these circumstances the circuit should not trigger.

To maintain constancy in operation, the H.T. supply to the valve-triggering circuit is stabilised to within  $\pm 1V$  at 250V.

#### *Holding Circuits for Fault Tracing from Cordless Switchboards.*

Provision has been made for call holding facilities from a cordless switchboard. This is necessary because an operator would be unaware of the circuit over which a call is established, and it may be necessary to hold a connection if fault conditions are experienced, to enable the maintenance staff to trace the faulty circuit.

To free the switchboard connecting circuit as soon as possible, the holding condition is taken over by a monitor and subsequently by operating a key on the record rack.

#### *Other Changes.*

The facility of testing from the trunk test racks at low signal levels has been extended down to -50 db. by adding an additional scale to the voltmeter (Voltmeter 36B). This has necessitated redesign of the negative feedback amplifier referred to in an earlier paragraph (Panel, Test TL 2647). The opportunity has been taken to specify preferred type valves and also to design the amplifier to operate from the same power supply unit as the Oscillator No. 32. The new amplifier which replaces Panel, Test TL 2647 is known as Amplifier AT 5203.

#### *Cathode-Ray Oscilloscopes.*

The provision of cathode-ray oscilloscopes is not related to transmission control or trunk mechanisation. The test cord circuit has provision for the association of an oscilloscope, but general provision will not be made and only test racks used for testing music circuits will be so equipped. It is proposed that such racks should be used for special fault investigations as well as testing music circuits and they will be equipped for this purpose with repeater-type testing equipment.

#### CONCLUSIONS

The widespread increase in the number of amplified circuits in the trunk network has led to a multiplicity of control points dealing with faults. To reduce lost circuit time it has been decided to reduce these control points by equipping trunk test racks so that transmission control work can be performed in trunk test rooms.

The pending changeover of the national trunk system to allow operator trunk dialling to objective exchanges had made it necessary to provide new facilities on and associated with trunk test racks. Circuits have been developed to cover busying, test access, and measurement of trunk circuits accessible from selector levels.

The facilities afforded by the self-answering relay sets and the automatic busying circuit should result in a considerable saving in maintenance time. It is expected that the savings effected will be sufficient to offset any additional time incurred in carrying out control duties from the test racks and make it possible to introduce the scheme without providing test racks in excess of the normal basis of provision.

#### ACKNOWLEDGMENTS

The advice and help of the author's colleagues in the preparation of this article are gratefully acknowledged.



# A Photographic Technique of Sound Recording on Glass Discs

A. J. FORTY, B.A., A.M.I.E.E.†

U.D.C. 621.395.625.6 : 778.534.4

This article describes the basic process of the glass disc recording technique used by the British Post Office for making records suitable for use in announcing machines such as the Speaking Clock. An important advantage of the method described is that the records so produced have an exceptionally long life.

## INTRODUCTION

RECORDINGS on glass discs have been made and used by the British Post Office for the past 17 years. The field of application of the technique is restricted, but within a somewhat limited sphere the method has advantages which are unequalled by any other form of recording.

The recordings are made, by a photographic process, in the form of circular sound tracks on discs of plate glass 12 in. in diameter coated with a suitable sensitive emulsion. From the negatives so obtained any number of positives (also on glass discs) may be made by a straightforward printing process. For reproduction of the sound a positive print is held by a central hub on a rotating shaft and the sound tracks are scanned optically.

The duration of the signal recorded on each track depends, of course, upon the rate of rotation for which the disc is designed; it is usually of the order of 1 to 2 sec. and rarely exceeds 5 sec. Consequently the main application of the process is for announcing machines which will reproduce short phrases of speech, or other signals, either singly or in combination and repeated at frequent intervals. It is particularly suited for this type of machine since there is no mechanical wear of the disc during use, and if certain precautions are taken to preserve the emulsion the life of the disc is virtually indefinite. The British Speaking Clock is an example of a machine employing this form of recording. The original discs fitted in 1936 were in continual use 24 hours per day until 1950, when they were replaced due to failure of the sealing of the cover glasses which protect the emulsion.

## THE RECORDING PROCESS

Fig. 1 shows a typical disc negative. Dual sound tracks are recorded in bilateral variable area form (see later description) each 2 mm. wide and normally spaced 1 mm. apart. The circumferential length of each track and its orientation depend upon the purpose for which the disc is designed, and these quantities are adjustable at will during recording. It will be seen from Fig. 1 that the beginning and end of each sector of track are tapered to avoid the audible clicks which would arise in reproduction if the track terminated abruptly. Dense, unmodulated, full-width tracks are invariably recorded near the centre of each disc to aid in centring the prints on their hubs (for which a series of standard sizes has been adopted).

For most applications a series of tracks of speech wave-forms is required. These are recorded by means of a copying technique. The sound to be reproduced is first recorded on conventional 35 mm. sound film which is processed, edited and the required phrases or words accurately selected. The recordings on the glass disc negative are then made progressively, track by track, copying the sound track from each piece of film on to the disc by means of a special recording camera. This method of recording the disc has two major advantages. By adopting a copying technique the manifest difficulties of recording short phrases as spoken are largely avoided. Suitable lengths of film are selected

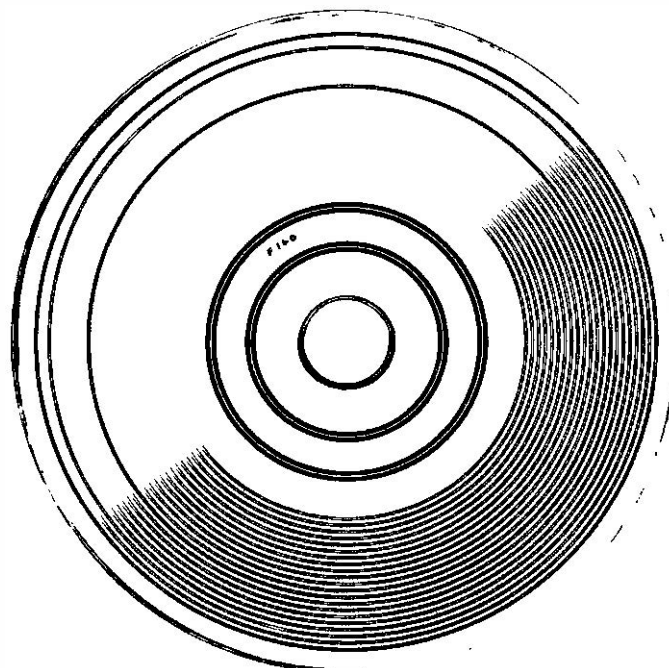

FIG. 1.— TYPICAL DISC NEGATIVE.

before recording commences, and there is no chance of the disc being spoiled because one of the recorded phrases is badly enunciated. Furthermore the correct orientation of the track is a function of angular measurement rather than of time synchronisation.

Secondly, the speed at which the copies are made is entirely arbitrary. A relatively slow speed is normally used, to permit the use of slow, fine-grain, high-resolution plates with corresponding increase in frequency range and reduction in the background noise due to grain size and low contrast. Shutter operations, fades, and the general manipulation of the camera are simplified when the recording speed is low, but there is introduced the drawback that the frequency range of the recording is translated to a lower region of the spectrum, with the result that the amplifiers used must be designed for sub-audio frequency working.

## THE RECORDING CAMERA

### General Description.

The recording camera is shown in Fig. 2. Inside the light-tight box (1) a sensitive plate is carried in a plate holder which is attached to the shaft (2). This shaft is torsionally rigid, and can be turned at constant speed by a phonic motor via the gearbox (3). Fixed to the other end of the shaft is a drum (4) round the flange of which a piece of sound film (5) is wrapped and clamped in place by a retaining band so that the sound track projects beyond the edge. A scanning unit (6) consisting of a light source, optical system, photocell and cathode follower produces electrical signals from the film sound track as the camera shaft rotates. These signals pass through amplifiers (7) and are applied to a mirror galvanometer (8). The latter modulates a light beam which, by means of the optical

† Senior Executive Engineer, P.O. Research Station.

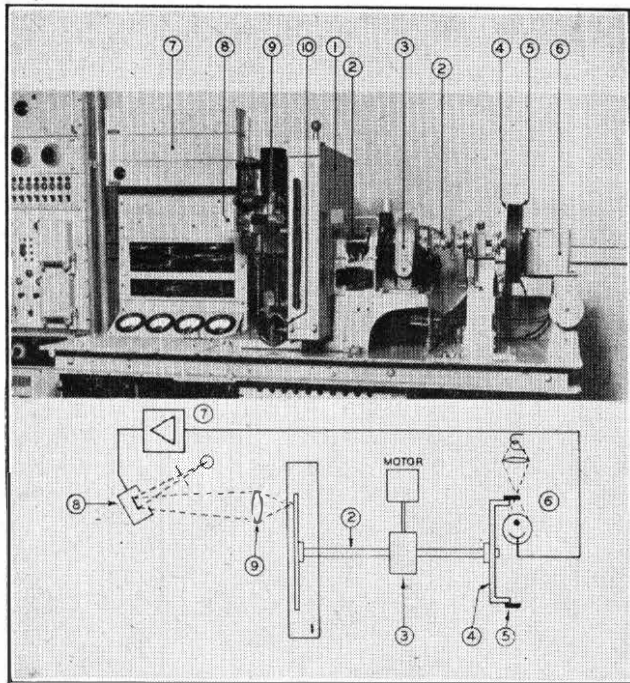

FIG. 2.—THE RECORDING CAMERA.

system (9), records on the sensitive plate a faithful copy of the film sound track. A "fading" device enables the recorded length of each track to be varied, while the circumferential position of the track is set by slackening a universal joint in the main shaft and making suitable angular adjustment of the film drum. The radial position of the track on the plate is adjusted by raising or lowering the optical system by means of a leadscrew operated by the handle (10). A mechanical shutter is operated by means of contacts associated with the driving mechanism to ensure that complete circular tracks may be recorded without double exposure.

The phonic motor which drives the main shaft will run satisfactorily at any speed between 100 and 1,000 r.p.m., corresponding to shaft speeds varying from one revolution in 200 sec. to one revolution in 20 sec. The flexibility in the choice of speed is convenient for two reasons. Firstly it enables an adjustment to be made in exposure for plates of different sensitivity (the exposure is, of course, directly proportional to the shaft speed). Secondly, by relating the speed of drive to the frequency of a pure tone applied to the galvanometer it is possible to record accurately an integral number of cycles of a given frequency on a complete sound track.

The diameter of the drum used depends upon the rate of rotation for which the disc is designed. Suppose that  $d$  in. be the drum diameter and that the finished disc when used must rotate at an angular speed of  $x$  r.p.m. Then, since the normal sound film speed is 18 in. per sec. and the perimeter of the drum is  $\pi d$  in., the time of one revolution of the disc when played back must be  $\pi d/18$  sec.

$$\text{Whence, } \frac{\pi d}{18} = \frac{60}{x} \text{ and } d = \frac{1080}{\pi x} \text{ in.}$$

A series of drums is available varying in diameter from 1.7 in. to 28.6 in., corresponding to disc speeds varying from 200 to 12 r.p.m.

The scanning unit for the film drums uses a 75W lamp, with an optical system which projects upon the film a slit image which has a width of approximately 0.0005 in. This will scan standard 35 mm. sound film without appreciable loss of high frequency response up to 10 kc/s. Vacuum photocells are used for stability and freedom from distort-

tion. A cathode follower is mounted in the same unit as the photocell. For certain applications (including copying) it may be necessary to mount a glass disc instead of a film drum on the camera shaft. A second scanning unit is available for reproduction from this type of source.

The scanning unit cathode follower feeds into a two-stage pre-amplifier of conventional design and this is followed by the galvanometer drive amplifier shown in Fig. 3. The

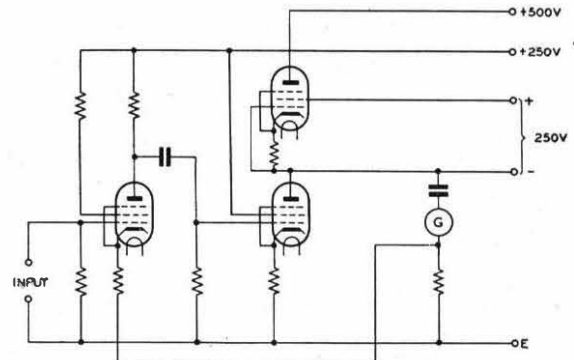

FIG. 3.—GALVANOMETER DRIVE AMPLIFIER.

latter uses a pentode in the anode feed of the output stage and has current feedback to the first stage. The output impedance is therefore high and the galvanometer is fed with substantially constant current, with a corresponding improvement in its frequency response.

The galvanometer is a moving-iron instrument with the armature and mirror carried on a stiff suspension of phosphor bronze giving a resonance frequency in the neighbourhood of 1,700 c/s. A copper ring has been deposited electrolytically upon the tip of the armature to give eddy current damping of the resonance peak. Large air gaps are provided in the A.C. flux path to improve the linearity.

A high pressure mercury vapour discharge lamp rated at 250W is used for recording. This lamp gives an intensely bright but compact source of light which enables slow plates to be given adequate exposure with practical camera speeds. The lamp is run from a D.C. supply through a dropping resistor, and the polarity of the electrodes is changed periodically to prolong the life.

Since with this type of source exposure cannot be controlled by variation of lamp brightness, neutral density filters are used for that purpose.

#### The Optical System.

The optical system of the camera is shown in diagrammatic form in Fig. 4.

The condenser lens (2) produces an image of the arc (1) on the blades of the compensating shutter (5) immediately

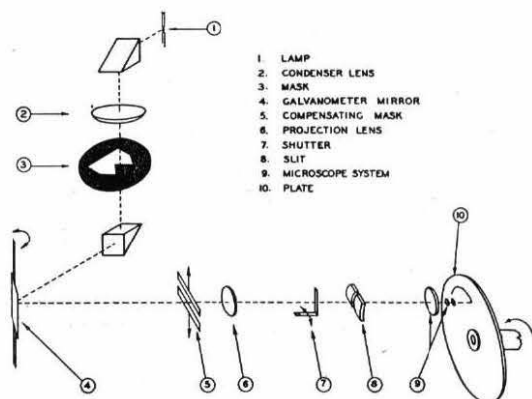

FIG. 4.—CAMERA OPTICAL SYSTEM.

in front of the projection lens (6). This compensating shutter is provided to control the amount of light which reaches the plate for tracks of different diameter. The effective exposure of a track is proportional to the amount of light,  $L$ , which passes through the optical system and inversely proportional to the velocity of the plate surface, i.e., to the diameter,  $D$ , of the track being recorded. The compensating shutter is controlled by the carriage upon which the optical system is mounted and is so arranged that the blades are fully open when the carriage is raised, i.e., when the outside track of the disc is being recorded. In this position the whole of the light from the arc passes through the projection lens. As the carriage is lowered for recording tracks of smaller diameter the compensating shutter blades gradually close in such a way that the ratio  $L/D$  is constant. In this way equally exposed tracks are automatically obtained. The projection lens throws an image of the mask (3) upon the slit (8), and the microscope system (9) forms an image of the slit upon the plate (10).

As the mirror (4) oscillates, therefore, so the image of the mask moves to and fro across the slit, and the intercepts of the wedges vary in amplitude in accordance with the magnitude of the signals fed to the galvanometer. The images on the plate of these two illuminated portions of the slit trace out two identical symmetrical waveforms, as shown diagrammatically in Fig. 5. The two waveforms

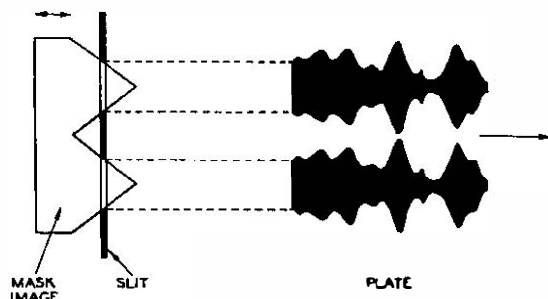

FIG. 5.—FORMATION OF SOUND TRACK (MICROSCOPE SYSTEM OMITTED).

collectively form a sound track of the type known as "dual bilateral variable area." This type of track has the advantages that less distortion is introduced either by possible variation of illumination along the length of the reproducing slit, or by misalignment of the reproducing optical system. The actual size of the recording slit is about 0.0015 in., and the optical reduction is 3 : 1. Consequently the effective width of the image of the slit on the plate is about 0.0005 in.

The shutter blade (7) ensures that a complete circle of track is exposed. It is operated by a relay circuit controlled by two cams, one on the main camera shaft and the other on the gearbox shaft which rotates at 50 times the speed of the former, thus ensuring accuracy of timing.

#### OPERATION

##### *Making the Negative.*

The plate holder, which holds the glass disc negative, can be rendered light-tight by the insertion of a dark slide and may be removed from the camera for loading in a dark room. The holder has been so designed that a photocell unit may be inserted in place of the disc and used in conjunction with a cathode-ray oscilloscope for checking depth of modulation and distortion when setting up. This device is also useful for determination of the correct position of the galvanometer for producing a balanced track.

The plate holder will also carry a small rectangular plate (4½ in. × 3½ in.). Plates of this size are available coated with the same emulsion as the glass discs, and are used to determine correct exposure, accuracy of shutter operations,

etc. After preliminary tests have been made the plate holder is loaded with a glass disc and inserted in the camera. The piece of film required for the first track is fitted to the drum, the optical system is set to the correct track radius, the coupling between plate holder and drum is adjusted to give the correct orientation of track on the disc, the cams controlling the fading device are set and a neutral density filter is inserted in the optical path to give the correct exposure. Finally, the shaft is set in motion, the shutter key is operated, and the complete track is then automatically exposed. After all the tracks have been thus recorded the plate is removed and processed in the normal manner.

##### *Positive Prints.*

Contact prints are made from the glass disc negatives on similar glass discs which are to be used in the reproducing machines. Each positive is normally fitted with a cover glass which is sealed to the disc round the circumference and round the central hole. The cover glass gives protection to the emulsion from mechanical injury and also prevents deterioration which might occur if the disc should be used in conditions of high temperature or humidity.

For applications where the reproduction speed is high (in one case a speed of 1,500 r.p.m. has been used), accurate balancing of the disc and hub is required. A technique has therefore been evolved for grinding the edge of the finished print to render the periphery truly circular and concentric with the tracks.

#### PERFORMANCE AND LIMITATIONS

##### *Frequency Response.*

As mentioned earlier, the use of a slow speed for the copying process modifies the frequency range with which the camera has to deal. Of course, if a frequency  $f$  is present in the film recording, it should also occur in the finished sound track on the disc. During the recording process, however, the corresponding frequency which passes through the scanning unit, amplifiers and galvanometer of the camera will be a frequency  $f'$  where

$$f' = f \times \frac{\text{velocity of sound film when copying}}{\text{normal velocity of sound film}}$$

$$= f \times \frac{\pi d}{18t}$$

where  $d$  = drum diameter in inches, and

$t$  = time of one revolution of camera shaft in seconds.

In practice the ratio  $f'/f$  may be as small as 1/200.

To determine the frequency range which the camera must cover it is convenient to think in terms of cycles per revolution of disc rather than of absolute frequencies.

The high frequency response of the finished glass disc is restricted by the size of the shortest wavelength which it is possible to record satisfactorily upon the plate. With the present equipment this is approximately 0.002 in. (the limiting factor in this connection being the optical system of the camera rather than the resolving power of the emulsion), giving a maximum number of 20,000 cycles which can be recorded on the outside track of a disc. The highest frequency to be dealt with by the camera is therefore that which is required to record 20,000 cycles per revolution at the fastest camera speed of 1 revolution in 20 sec., i.e., 1,000 c/s.

At the low frequency end of the spectrum the frequency response of a disc may be required to extend down to 50 c/s. For speech, disc playback speeds greater than 60 r.p.m. are seldom used because the phrase duration is impractically small. So the lowest number of cycles per revolution of disc required is 50 (which reproduces at 50 c/s on a 60 r.p.m. disc). The lowest frequency with which the camera normally

deals is therefore that required to record 50 cycles per revolution at the slowest camera speed of 1 revolution in 200 sec., i.e., 0.25 c/s.

The frequency response of the camera system must therefore extend from 0.25 c/s to 1,000 c/s, a range of 11 octaves.

The extent to which these requirements have been met is shown in Fig. 6.

Curve (a) shows the variation in current through the galvanometer for constant excitation of the film drum photocell, which was obtained by playing back pure-tone sound tracks at a variety of speeds.

Curve (b) shows the variation with frequency of the sensitivity of the galvanometer with constant current through the coil. For this curve the ordinate represents the depth of modulation of the recording light beam, which was measured by means of a photocell substituted for the sensitive plate.

Curve (c) is the sum of curves (a) and (b), and represents the overall frequency response characteristic of the camera system.

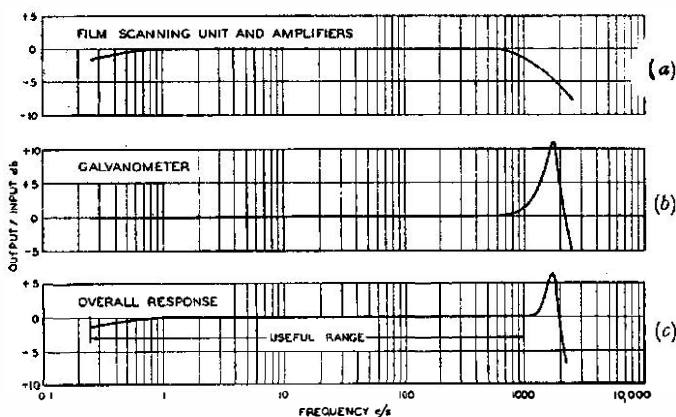

FIG. 6.—FREQUENCY RESPONSE OF RECORDING CAMERA.

Most of the applications of glass discs are concerned with speech of telephone quality and require a frequency response which need not extend beyond 3,500 c/s. This can be achieved on the outside tracks of a disc with a disc speed as low as 12 r.p.m. and a phrase length of 5 sec. Under these limiting conditions flatness of disc is important, both when recording and when playing back, for serious loss of high frequency response may otherwise be caused by defocusing.

#### Distortion.

Harmonic distortion may be present in the final print for a variety of reasons. If the original recording of speech has been made on magnetic tape and transferred to the sound film from which the disc tracks are copied then either of the first two media may introduce distortion.

The camera itself, including amplifiers, galvanometer and optical system, gives comparatively little distortion if properly adjusted. It is important that the galvanometer armature be accurately centred in its gap and that the illumination of the recording mask be uniform. If suitable precautions are taken it is possible to restrict the second harmonic introduced in the camera to less than 2 per cent, and the third also to less than 2 per cent.

Further distortion may arise in the processing of the negative and of the positive print, due to image growth or retraction.<sup>1</sup> This effect is illustrated in Fig. 7, where the waveform (a) is that which is obtained from an under-exposed or under-developed negative, (c) results from over-exposure or over-development, and (b) shows the correct condition. The presence of this form of distortion may

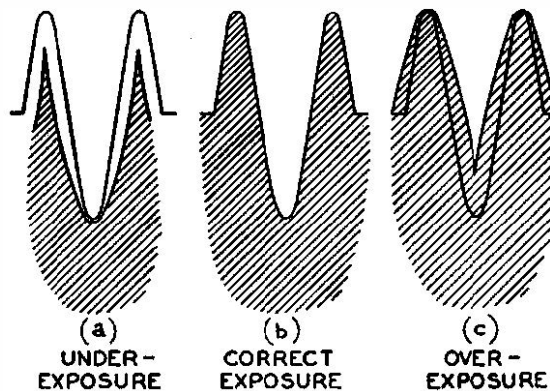

FIG. 7.—IMAGE GROWTH DISTORTION.

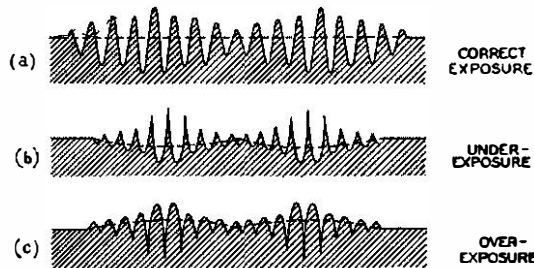

FIG. 8.—DISTORTION CONTROL TRACK.

readily be demonstrated by recording and playing back an amplitude modulated waveform of the type shown in Fig. 8. (For simplicity only one track envelope is shown.) If the correct exposure has been given then the mean amplitude of the recorded waveform (shown by the dotted line) is constant, and no low frequency is detected upon playback. If, however, over-exposure or under-exposure is present, then the low frequency can be measured. Since the image growth effect is most troublesome at high frequencies, 9,000 cycles per revolution are used for the carrier and the modulating frequency is chosen to give 400 cycles per revolution.

For reasons which will be discussed in the next section, the density of the final print is required to be high, a condition which would normally give rise to the distortion of Fig. 7 (c). It is, however, possible to correct for the over-exposure of the print by first producing a negative which also has a controlled amount of over-exposure. A normal print from such a negative would give distortion as in Fig. 7 (a), but the over-exposed print adds just sufficient image growth to give a final waveform which is correct. It is now normal practice to include on each glass disc negative a sound track of the type shown in Fig. 8. Test prints are made with varying exposure and processed in the normal way. The exposure which is found to give minimum distortion is then adopted for any further prints required.

#### Signal/Noise Ratio.

Background noise is the most serious limitation of the present glass disc process. With good quality magnetic recording or with lacquer discs a signal/noise ratio of 60 db. can be obtained, but with glass discs it is usually of the order of 30 db. The high noise level is due partly to the emulsion and partly to the base. The discs are coated by hand with an emulsion which is extremely thin; consequently the incidence of pinholes and dust particles is considerably greater than is the case with machine-produced sound film stock. Furthermore, the plate glass base has been found to carry minute inclusions of rouge which are left in the small craters which remain after the polishing



process. These imperfections of the glass are not visible to the naked eye, but contribute largely to the elevated noise level when they occur in the clear portions of the sound-track. It is possible by fine polishing to effect a considerable improvement (about 6 db.) in the signal/noise ratio of the discs. Also, by obtaining final prints of high density, as described in the previous section, the noise due to pinholes in the dense portion of the sound track can be reduced (since these pinholes are filled in by the image growth effect).

#### Drive Speed Flutter.

When negatives are made by the copying process the plate is rigidly coupled to the film drum, and variations in the speed of rotation will not result in corresponding modulation of the sound tracks. Flutter in the drive is, however, undesirable because it gives rise to density modulation.

Normal sound tracks of full density do not show this modulation, but it is liable to contribute to the background noise by reason of its presence in the edge of the track where there is a fringing region of lower density owing to the finite size of the recording slit. "Wow" in the drive will also, of course, adversely affect tracks which are recorded direct from an oscillator instead of by copying from film or plate.

Considerable care has been taken to ensure that the speed of rotation of the camera shaft is as constant as possible, by the insertion of suitable flexible couplings between the phonic motor and the high speed shaft of the gearbox, which is coupled to a large flywheel.

#### METHODS OF APPLICATION

No standard equipment exists for playing back glass disc records. Consequently a machine must be designed for each new requirement as it occurs. The machines so far made fall, broadly speaking, into two categories according to the method employed for scanning the sound tracks. The first class, to which the British Speaking Clock belongs, scans each track individually with a unit similar to that used on most sound film projectors, while the second scans a projected image of a group of tracks. The two types are described in the following sections.

#### Scanning by Unit Optical System.

Fig. 9 illustrates a simple machine which has been designed to give congestion announcements (of the form "No lines at London") for use with automatic trunk working.

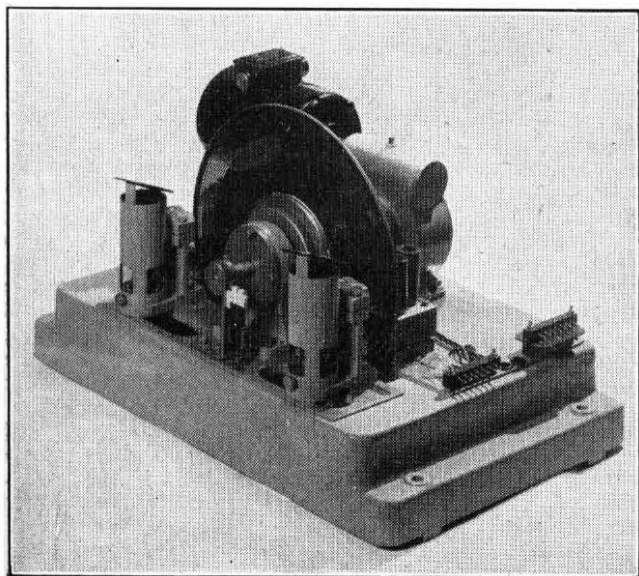

FIG. 9.—SIMPLE ANNOUNCING MACHINE.

The glass disc is mounted on a shaft which is driven through a gearbox by a synchronous motor. Several sound tracks of the type quoted above are recorded upon the disc: only one of these is used at each Group Centre where a machine is installed, but the number of different discs which must be recorded is thereby reduced. The machine has two scanning units consisting of lamp, optical system and cathode follower. The first of these reproduces the "No lines . . ." track required (its position can be adjusted accordingly) and the second is used to scan a track bearing the words "Test Call" used for routine testing. The disc also carries a distortion control track as described previously.

The Speaking Clock<sup>23</sup> is a more elaborate machine of this type with a controlled motor drive and facilities for changing the announcements to suit the time. The complete announcement is of the form "At the third stroke - it will be twelve - fifty nine-and ten seconds - pip, pip, pip." The hyphens indicate the way in which this announcement is subdivided for reproduction. Certain parts of the announcement ("At the third stroke" and the "pips") do not change, and are reproduced by fixed scanning units. The remaining components of the phrase are reproduced by scanning units which are mounted upon moving carriages, and a control mechanism alters the position of these to conform with correct time and selects the output of the relevant photocell when required. Auxiliary apparatus is provided which ensures accurate time-keeping, gives automatic correction of the clock at periodic intervals by comparing its signals with those from an observatory, and gives continuity of service by causing changeover to duplicate equipment in the event of failure or false operation of a component part of the system.

#### Projected Scanning.

Fig. 10 shows a machine which is an elaboration of the Congestion Announcer described above. In addition to the "No Lines at London" announcement this equipment

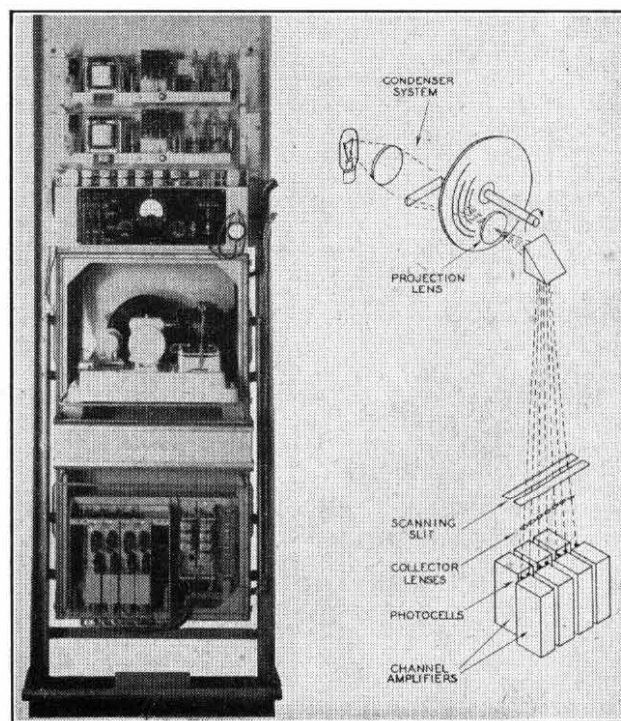

FIG. 10.—PROJECTION-TYPE ANNOUNCING MACHINE.

provides other phrases of the form "Delay half (or one, two, three) hour(s) at London", "Refer to Records" and "Test Call." All seven announcements are available continuously from one disc.

In the diagrammatic illustration a projection lens forms an image of a portion of the disc upon a slit, under which a row of photocells reproduce the series of enlarged sound tracks. For the simultaneous reproduction of several tracks this system shows considerable economy over the use of individual scanning units. Furthermore a comparatively large slit can be used for scanning since its effective size is reduced owing to the magnification of the projection system.

#### CONCLUSION

It has been possible in this paper to describe only the basic process of the glass disc recording technique. The method is flexible and lends itself to the manufacture of other types of record than speech sound tracks: for example discs bearing recordings of teleprinter test signals and "warble" tones have been made. There is little doubt many other such applications will arise in the future.

#### ACKNOWLEDGMENTS

The thanks of the author are due to Dr. E. A. Speight who was responsible for the early development of this system of sound recording, to Mr. F. A. Milne who has done much of the later work, and to his other colleagues at the Research Station who have helped in the preparation of this article.

#### References.

- <sup>1</sup>"Modulated High Frequency Recording as a Means of Determining Conditions for Optimal Processing," J. V. Baker and D. H. Robinson, *Journal of the Society of Motion Picture Engineers*, Vol. 30, p. 3, January 1938.
- <sup>2</sup>"The Post Office Speaking Clock," E. A. Speight and O. W. Gill, *Journal of the Institution of Electrical Engineers*, Vol. 80, p. 493, May 1937.
- <sup>3</sup>"The Speaking Clock (Part 2: The Clock Mechanism)," E. A. Speight and O. W. Gill, *P.O.E.E.J.*, Vol. 29, p. 263.

## Book Reviews

"Statistical Methods In Electrical Engineering." D. A. Bell, M.A., B.Sc.(Oxon.), Ph.D., M.I.E.E. Chapman & Hall, Ltd. 175 pp. 29 ill. 25s.

This book outlines some applications of statistical mathematics to the solution of electrical engineering problems. It consists of ten short chapters, each of which is concerned with the application of some particular statistical concept. Since the chapters are practically independent, they can be read in any order. Thus, the reader who wishes to learn something about the dangers involved in basing judgments upon the evidence supplied by small samples could start with Chapter VII which discusses the reliability of data. It will be recalled that by virtue of Student's t-test it is an easy matter to determine from a small number of observations the confidence limits to be attached to an estimated value of the unknown mean of the sampled population. Yet in Chapter VII, the complete discussion of this fundamental t-test has been condensed into a single paragraph. In this paragraph, the mean and variance of the sampled population are assumed to be known, in spite of the fact that in the great majority of electrical engineering problems these parameters are unknown, and have to be estimated from a few sample items. Owing to the omission of a proper treatment of Student's theorem it follows that the book cannot discuss the problems involved in the estimation of population parameters from small samples, or the fixing of confidence limits to small sets of measurements, or the analysis of variance, or the design of experiments, or, in fact, any of those important statistical methods that have grown from the fundamental theorem of the theory of small samples.

The reader who is familiar with the methods of Fourier analysis will find Chapter VI of particular interest. This chapter is concerned with the application of periodograms and autocorrelation functions to the analysis of non-periodic wave forms (such as random noise, speech or telegraph signals) that are specified by their statistical properties and not by the usual explicit formulae. This chapter should appeal to those readers who wish to see how Fourier analysis can be extended by the introduction of statistical concepts. Chapter IX contains a very interesting discussion of the fluctuations of electric currents in valve circuits. Other chapters are concerned with curve fitting, information theory, etc.: but the mathematical discussion is very sketchy and leaves a lot to be desired; for example, in Chapter III, the author discusses the Binomial, Poisson, Normal, Maxwell-Boltzmann and the Fermi-Dirac distributions without using a single graph to illustrate points of difference. Also, numerical examples are few and far between. Some chapters call for a deep knowledge of mathematical physics and are not suitable for beginners.

The fact that this book is not suitable for beginners is illustrated by the confused and misleading discussion of the foundations of probability theory given in Chapter I. This discussion gives the erroneous impression that disagreement exists among mathematicians concerning the basic mathematical structure of probability theory. Actually, there is no disagreement concerning mathematical facts and the mathematicians referred to in Chapter I (and quoted out of context) were merely debating whether certain statements should occupy the place of axioms or of theorems. Mathematicians to-day recognise probability as a branch of Measure Theory: for without this theory it would be impossible for them to treat probability upon strictly mathematical lines. The measure theoretical approach leads to no paradoxes or difficulties, and its greatest advantage is that it substitutes precise theorems for the vague and wholly philosophical discussions like that given in Chapter I. But Measure Theory is a new branch of mathematics (it embodies the axiomatic treatment of the foundations of probability theory given by Kolmogoroff less than 20 years ago) and it is possible that the author has never heard of it; for otherwise it is hard to imagine how Chapter I ever came to be written.

H. J. J.

"Electrical Installation Rules & Tables"—Fifth Edition. W. S. Ibbetson, B.Sc., A.M.I.E.E., M.I.Mar.E. E. & F. Spon, Ltd. 210 pp. 7s 6d.

This is a genuine pocket book measuring 5" x 4" x  $\frac{3}{4}$ " thick. It was first published in 1921. There are approximately 200 pages. The first half contains a digest of those Regulations for the Electrical Equipment of Buildings that are most frequently consulted. The author has quoted some *in extenso* but has interpreted others, presumably for the benefit of the practical man. This section of the book should be used therefore only as a guide and the author gives a warning to this effect. Some 30 pages are devoted to the design of lighting installations and there is some very useful information here. The remainder of the book is occupied by the tables that one would expect to find in a pocket book of this description. There are also notes on common faults on A.C. and D.C. motors and generators, a comparison between high rupturing capacity fuses and the rewirable type, calculations for electric heating and a wages table. Although the type is small it is very clear and the matter is well laid out. The paper and binding are good but materials more suitable for use in a workshop could have been employed. The use of the first three words only of the title on every page seems inappropriate in the sections on lighting and tables. This is a type of book that the Engineer inspecting electric lighting and power plant often wishes he had with him.

A. E. P.

# Improvements to the 2000-Type Selector

E. H. SEYMOUR, A.M.I.E.E.†

U.D.C. 621.395.342.22:621.395.6

This article summarises the improvements made to the 2000-Type Selector since its introduction in 1932 and gives details of the improvements made to mechanically operated spring-sets, magnet interrupters and wipers.

## INTRODUCTION

THE 2000-type Selector, first introduced by the Automatic Telephone & Electric Co. in 1932, was adopted subsequently by the Post Office as the standard two-motion selecting mechanism. The general mechanical features have been described previously,\* and this article covers improvements made since the introduction of the selector.

Minor improvements, some of them arising from improved manufacturing techniques, have already been incorporated. These include the spinning of the rotary cam and disc on to the carriage instead of screwing; the provision of an additional bearing surface for the level-spring operating cam; the provision of a reversible clamp for the line and private wipers; the extension of case hardening on various rubbing and striking parts; and an improvement to the means of soldering the rotary ratchet to the carriage by a method of high frequency heating. In addition an anti-bounce plate has been fitted to the bridge plate to reduce the amplitude of vertical rebound of the carriage during homing.

The major improvements, however, concern the mechanically operated spring-sets; the magnet interrupters; the vertical marking bank and wiper; and the line and private wipers. These are discussed in further detail below.

## MECHANICALLY OPERATED SPRING-SET ASSEMBLIES

### General.

A view of a selector mechanism fitted with the new type spring-sets is shown in Fig. 1; and a typical individual

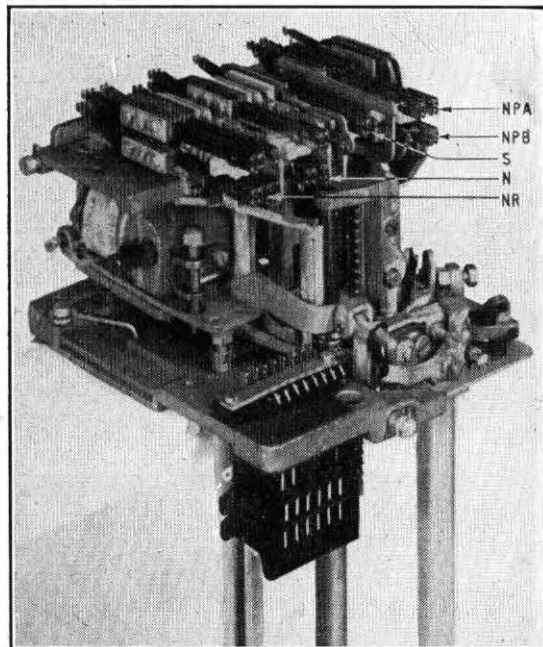
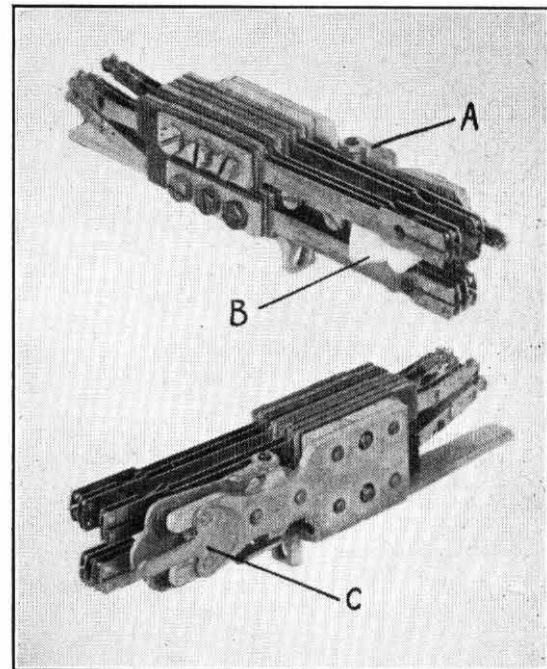

FIG. 1.—SELECTOR MECHANISM WITH NEW SPRING-SETS.

assembly, and exploded view to indicate the parts, are shown in Figs. 2 and 3.

The spring-sets are provided with buffer blocks, and the



A.—Auxiliary Armature. B.—Buffer Block. C.—Operating Lever Back-Stop.  
FIG. 2.—TWO VIEWS OF A TYPICAL SPRING-SET ASSEMBLY.

general basis of design follows that of 600-type relays. The buffer blocks and spring-set assemblies are mounted on a steel fixing bracket, which is itself secured to the selector casting by means of a single screw fixing at the front, and a locating lug at the rear.

The fixing brackets for the N, NR and S spring-sets also carry a pivoted auxiliary armature, movement of which operates both piles of spring-sets simultaneously. The auxiliary armature is operated by the upper arm of an operating lever, the latter being controlled by the movement of the selector carriage. For the NP spring-set, the NPA and NPB spring piles have to be operated indepen-

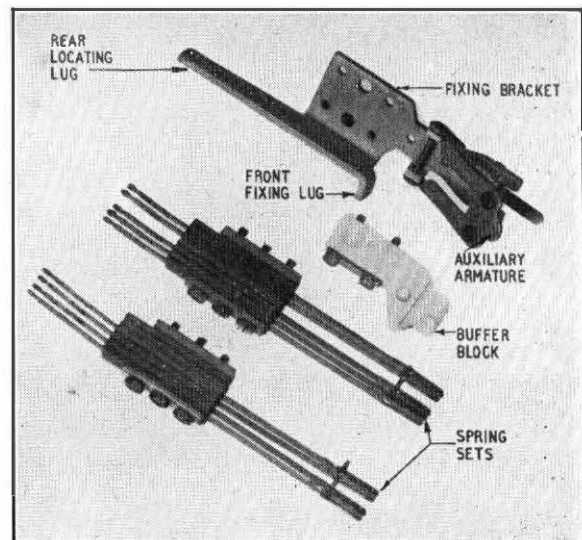

FIG. 3.—EXPLODED VIEW OF TYPICAL SPRING-SET ASSEMBLY.

† Executive Engineer, Telephone Development and Maintenance Branch, E.-in-C.'s Office.

\* P.O.E.E.J., Vol. 28, p. 249.



dently of one another; the auxiliary armature in this case is therefore dispensed with, and each spring pile is operated directly by its own operating lever.

The thickness of the contact springs has been increased (compared with those for 600-type relays) from 14 mils to 16 mils to reduce the likelihood of false contacting caused by vibration when the selector is stepping; and the wiring tags have been offset, to permit of easier access for wiring and maintenance.

#### Operating Levers.

The change of the dimensions and configuration of the spring-set assemblies requires the use of a new set of operating levers. In addition a modification has been made to the NR and S levers. These were provided originally with a roller to engage with the rotary cam on the selector carriage. Breakage of the roller bearings occurred in service, and since it was found that in many cases the roller did not rotate, it was fixed to its bearings by a special brazing process. To facilitate manufacture a change was made later, to produce the levers in a one-piece steel pressing for the NR and S positions. Fig. 4 shows the old and new type levers.

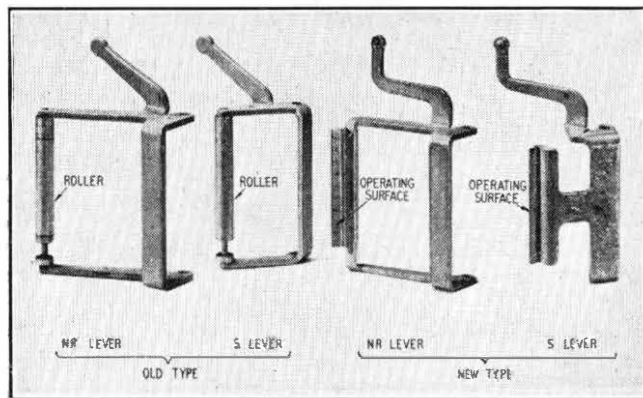

FIG. 4.—OLD AND NEW TYPES OF NR AND S OPERATING LEVERS.

#### Operating Loads.

The reduced travel and thickness of the springs, compared with the existing type, cause a reduction of about 30 per cent. in the total operating load of the larger spring piles, and hence increase the factor of safety available for the operation of the vertical and rotary magnets.

#### Adjustment and Spring Numbering.

Spring adjustment is identical in principle with that of 600-type relays. The "make" and "break" springs are tensioned against the buffer block steps with a pressure of 20-35 grams, and the lever springs are tensioned against the lifting stud of the auxiliary armature with a minimum pressure of 5 grams for individual springs, with an overriding maximum of 30 grams total for all the lever springs in any spring pile.

Numbering of the springs also follows relay practice, i.e. the left-hand springs are numbered 1, 2, 3 . . . upwards, and the right-hand springs 21, 22, 23 . . . upwards, viewing the springs from the front, and with the auxiliary armature at the bottom.

#### Maximum Spring Capacities.

The maximum number of springs which may be fitted in the N, NR and S positions is not conditioned, as it is with the existing springs, by the number of springs fitted in an adjacent position. A maximum of 12 springs (five contact units) may be fitted unconditionally in each of these positions, representing an increase in maximum

capacity of about 30 per cent. The maximum number of springs in the NP position remains the same as with the existing springs, viz. six springs (three contact units).

#### Use of Bias Spring in NP Position.

When a single make or break spring only is fitted in either the NPA or NPB position there is a tendency for the operating arm of the auxiliary cam to disengage prematurely from the level cam during rotary stepping of the selector. To prevent this, the pressure of the arm against the level cam is increased by fitting a bias spring to all single break contact units, and tensioning it against the buffer block with a pressure of 20-35 grams. On single make contact units the pressure of the lever spring against the operating lever is increased from 5 grams minimum to 20-35 grams.

The bias spring has neither a soldering tag nor contacts, and has no electrical connections made to it.

#### Balanced Loading.

With relays an effort is made to equalise the pressures exerted by the left- and right-hand spring piles on the armature. This is because the armature operates on a knife-edge and unbalanced loading may cause the armature to tilt. With the mechanically operated spring-sets, the auxiliary armature pivots about a bearing pin, and tilting cannot occur. Consequently balanced loading of the left- and right-hand spring piles is not necessary.

### MAGNET INTERRUPTERS

#### General.

Figs. 5 and 6 show views of the new rotary magnet interrupter fitted with break contact springs; the vertical magnet interrupter is of the same type except for the configuration of the lower part of the operating arm which is struck by the magnet striker.

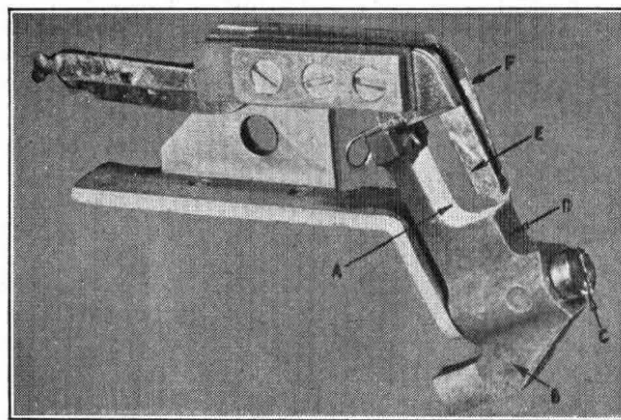

A.—White surface. B.—Operating Arm. C.—Pivot of Operating Arm. D.—Shoulder of Operating Arm. E.—Stationary Contact Spring. F.—Moving Contact Spring.

FIG. 5.—THE NEW ROTARY MAGNET INTERRUPTER ASSEMBLY.

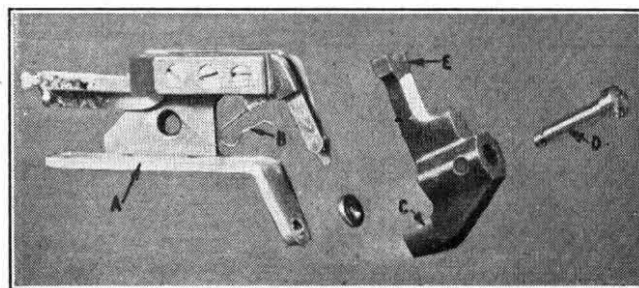

A.—Mounting Bracket. B.—Toggle Spring. C.—Rounded Sides. D.—Bearing Pin (Pivot). E.—Fork-shaped Extension.

FIG. 6.—EXPLODED VIEW OF ROTARY MAGNET INTERRUPTER ASSEMBLY.



The principle of operation, and the nominal contact pressures between the contact springs remain unchanged. However, by altering the dimensions of the leverage system so that an increase of distance is obtained between the toggle spring and the pivot of the operating arm, it has been possible to reduce the toggle spring tension, which makes for easier and longer lasting adjustment, and reduces the forces required to operate the system.

#### Contact Springs.

Each contact action (make or break) consists of two nickel silver springs; an inner "stationary" spring 20 mils thick, and an outer moving spring 10 mils thick. The latter is operated at its lower extremity by a shoulder of the operating arm. The "stationary" spring has sufficient flexibility to enable it to yield slightly under the impact of the moving spring, and after impact, the two springs oscillate together for a short period, but without the contacts opening. The result is an almost complete elimination of contact bounce together with improved contacting due to the rubbing action.

The contact springs have, in addition, been lengthened and widened at the base. This facilitates tensioning and ensures high stability of adjustment and contact pressure. The contacts are of platinum and of large diameter. The whole combination reduces contact bounce, pitting and wear, and ensures a longer life with fewer and easier re-adjustments.

#### Operating Arm and Pivot.

The operating arm is a bakelite moulding, reinforced with a medium shock filler to toughen it, and render it proof against breakage or chipping as the result of the impact stresses imposed on it by the magnet striker. The face immediately behind the contact springs has a white reflecting surface to facilitate adjustment of the contact clearances.

The two limiting positions for the operating arm are governed by the provision of a stop, in the form of a fork-shaped extension on the top of the arm. In the limiting positions the limbs of the fork engage with a projection from the spring assembly. The toggle spring is positioned and secured between this projection and the centre of the fork. The lower part of the operating arm which is struck by the magnet striker has its sides rounded slightly to ease the adjustment and measurement of striker clearances.

The pivot is a large diameter brass or steel bearing pin which overcomes any tendency to bend or twist at this point. It is lubricated initially with a smear of a special general-service grease, and further lubrication should not normally be necessary during service.

#### Mounting Bracket.

The contact spring assembly, and the operating arm and pivot are mounted on a steel bracket, provided with two tapped holes in the bottom flange. The bracket is secured to the selector casting through these holes with two screws and lock washers.

### LINE AND PRIVATE WIPERS

#### General.

Fig. 7 shows the wiper (Wiper No. 12) used at present on the 2000-Type Selector. This wiper is characterised by the presence of a fibre collar, which binds the two wiper blades together to form a "balanced pair". The plane of the bank contacts cannot always be guaranteed throughout the whole of its length to lie in the plane of the centre line between the wiper tips. If it rises or falls, the contact pressure of the two wiper blades (with no collar fitted) will differ from each other as the wiper rotates round the bank,

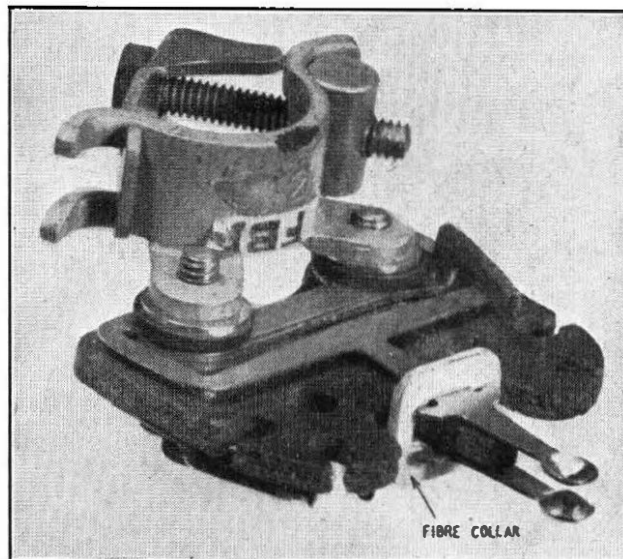

FIG. 7.—WIPER NO. 12.

and the original purpose of the collar was to equalise this pressure. It has since been ascertained, however, that the use of the collar results in the almost complete elimination of wiper bounce.

It is necessary to ensure that when the wiper cuts-in to a bank level, it does so cleanly, without jamming on the edge. If, at the instant of rotary cut-in, the centre line between the wiper blades is in line with the bank level, the Wiper No. 12 cuts-in cleanly and no difficulties ensue. If, however, the height of the wiper dome is too small, jamming of the wiper tip on the edge of the bank level is liable to occur. This is illustrated in Fig. 8.

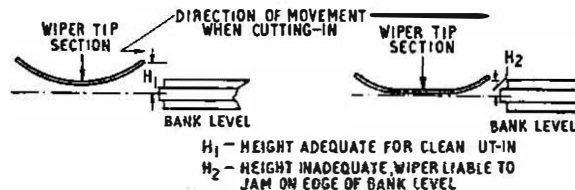

FIG. 8.—EFFECT OF WIPER DOME HEIGHT ON CUTTING-IN TO BANK.

#### Improvements to the Wiper No. 12.

An investigation of wiper faults showed that most of the difficulties occurring were due to insufficient tip dome height and inadequate outward tension of the blades against the collar. These deficiencies were rectified by the issue of a specification laying emphasis on these two points. Further points of improvement to be made are listed below:—

**Dome height.**—Unsatisfactory wiper cut-in is liable to occur when the dome height is 30 mils or less. The height of the present wiper tip when new is 38 mils but this is reduced to 28-30 mils when the wiper is worn, and due for replacement. To ensure a greater margin of safety during the life of a wiper, the dome height is being increased to 42 mils minimum, and to enable this depth to be obtained in manufacture, a slight change to the shape of the wiper tip is being made.

**Wiper cords and soldering tags.**—The hole in the separating insulator through which the terminating wiper cord passes is being enlarged and elongated to permit of easier withdrawal of the cord tag when a wiper is changed.

**Clamping bracket.**—This bracket is being replaced by a steel spring, shown in Fig. 9, which closes round the carriage over the whole of its surface, and prevents indentation of the carriage tube.

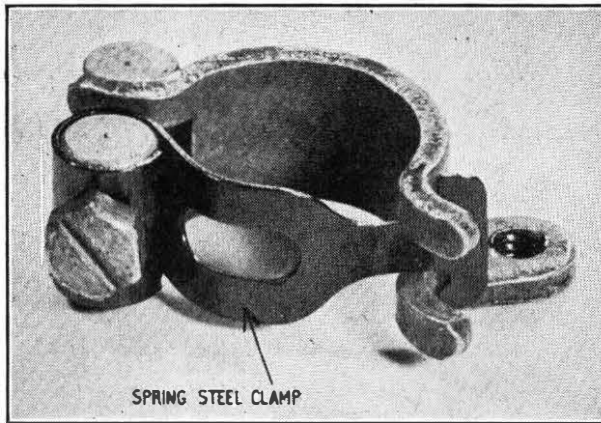

FIG. 9.—NEW CLAMP FOR SECURING WIPER ASSEMBLY TO CARRIAGE.

*Wiper blades.*—The nickel content of the nickel-silver blades is being increased from 12 per cent. to 18 per cent. This increases the "springiness" (modulus of elasticity) of the material, and should enable it to retain its tension as a spring rather longer than at present.

*Material for Wiper Blades.*

Tests have been made on blades of brass, phosphor-bronze, leaded phosphor-bronze, stainless steel, copper nickel and nickel silver and also on base metal blades tipped with chromium, silver, and various precious metal alloys. The result of all these tests shows that nickel silver is the best all-round material so far as the British Post Office is concerned, hence it is being retained.

Further investigations on contact materials are, however, being made.

VERTICAL MARKING WIPER AND BANK

*Wiper Assembly.*

*Reduction of contact bounce.*—The reduction of contact bounce resulting from the fitting of a collar around the wiper blades has already been referred to in the section on the line and private wipers. The fitting of a collar proved equally effective in reducing contact bounce on the vertical marking wiper, and Fig. 10 shows the assembly finally adopted. The collar is easily withdrawable without distorting the nickel silver blades, and the latter have been

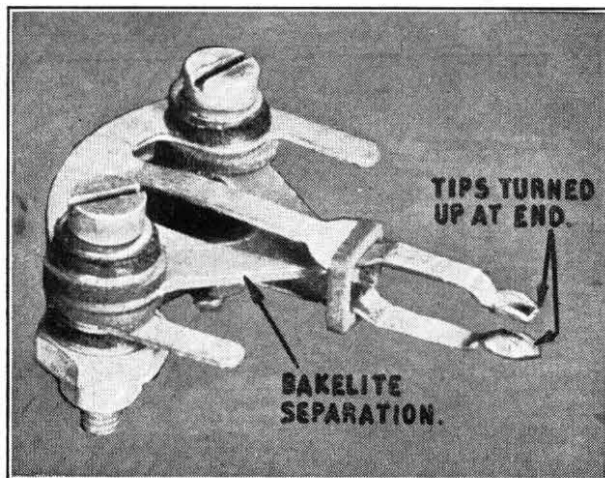

FIG. 10.—GENERAL VIEW OF VERTICAL MARKING WIPER ASSEMBLY.

reduced in width between the collar and the tip to limit the rise of contact pressure on the ribbed insulation of the bank when the wiper tips pass over it. This is to prevent the ribbed insulation from wearing too rapidly.

The extreme end of the wiper tip is turned up so as to allow the wiper blades to slide easily on to the bank, without the risk of jamming and buckling, when the wiper is being inserted to engage with the bank after a selector has been placed in its cradle.

*Wiper vertical overshoot.*—The wiper tip itself has been still further reduced in width. This enables it to become more tolerant of the vertical overshoot from the bank contacts which occurs during vertical stepping of the selector, because the tip can then ride further up the bank contact before it is lifted from it (to cause a circuit disconnection) by the ribbed insulation. With the narrow tip, and with the wiper positioned so that its tip lies one-third up the bank contact in the stationary position, circuit disconnections arising from vertical overshoot become negligible.

*Wiper life and performance.*—The reduced contact bounce resulting from the new wiper assembly lessens considerably the pitting and wear of the wiper tips, and enables a longer life to be obtained. The reduction of contact pitting, and the virtual elimination of circuit disconnections caused by wiper overshoot also ensure a positive circuit operation via the vertical marking wiper and bank.

*Vertical Marking Bank.*

No change to the vertical marking bank has been implemented at the time of writing, but the following changes are under consideration and may be applied later:—

1. The provision of elongated fixing holes in the bank mounting plate so as to permit a small movement of the whole bank in the up and down direction to facilitate the adjustment of the position of the wiper tips on the bank contacts.
2. The provision of the bank with the contacts flush with the insulation. There were objections in the past to the use of a flush bank with the existing type of wiper assembly, but the indications now are that with the new wiper assembly a flush bank will give an improved overall performance.
3. The strengthening of the extended arm of the auxiliary bank sector which supports the vertical marking bank.

CONCLUSIONS

The greatest benefit from any improvement is obtained when the new item is interchangeable with the existing item, because the improvement may then be applied to apparatus already existing in the field. It is of interest to observe that the improved items described above are all fully interchangeable, as complete items, with their corresponding components of the original design.

ACKNOWLEDGMENTS

Acknowledgment is made to the Automatic Telephone & Electric Co., Ltd., and to various members of the Telephone Branch who were concerned with the development and testing of the items described. Appreciation is also expressed to the A.T. & E. Co. for permission to reproduce illustrations from the *Strowger Journal* of October 1952 for Figs. 1, 2 and 3 of this article.

# Electronic Solution to an Agricultural Problem

U.D.C. 621.397.3:531.72:519.24

THE most usual contact between the Post Office Engineering Department and agriculture is probably by way of provision of subscriber service to farms, but the science of electronics is now finding application in many diverse fields of measurement and recently the Agricultural Research Council sought the co-operation of the P.O. Research Station to develop a measuring instrument of a special nature<sup>1</sup>.

In the study of spray-producing devices (for insecticides etc.) it is necessary to find out the size-distribution of the droplets produced. The method employed till now has been to examine visually the spot-patterns collected on sampling sheets of absorbent paper, the solution being dyed to increase contrast. Either complete sheets were examined with a magnifier and a measuring graticule, a laborious process, or small sample areas, selected by an "experienced eye", were measured; the accuracy achieved by this latter means is a matter of conjecture. A typical time for the thorough measurement of a sample comprising 1,800 spots is 8 hours.

To increase the speed and reduce the labour of examining samples was the problem set. The obvious approach was to employ some suitable automatic scanning system with a counting device. The basis of the method is to scan the sample in straight lines at a uniform interval and count, in different size-groups, the intercepts which are made on the scanning lines by the spots. If certain assumptions can be made about the shape of the spots and the distribution within the groups into which the whole size-range is divided, mathematical relationship between the intercept-length distribution and the spot-size distribution can be deduced.

The scanner adopted is a conventional photo-telegraph transmitter. The sample sheet is fastened to the drum which is rotated at constant speed and also traversed axially at a uniform rate by a lead-screw mechanism. A portion of the drum surface is flood-lit and an image of it is projected optically on to a scanning aperture, the light passed by the aperture exciting a photo-cell. The photo-cell current modulates a carrier in accordance with the light reflected from an element of the sample sheet. The signal from the scanner is demodulated and limited in amplitude so that a two-condition output is produced, indicating that either the background of the sample sheet ("white level") or a portion of a spot ("black level") is being scanned; hence intercepts are now indicated by black-level signals of duration proportional to intercept length. These signals are applied to an electronic integrator so that they are converted to pulses of final amplitude proportional to duration, and the resultant train of pulses of varying amplitude is presented to a group of voltage discriminators, each of which is adjusted to be triggered when the amplitude of a pulse exceeds a particular reference potential. The reference potentials were chosen to correspond to intercepts of 0.5, 0.7, 1.0, 1.4, 2.0, 2.8, 4.0, 5.7 and 8.0 mm. for a scanner speed of 2 r.p.s., these lengths being halved for a speed of 1 r.p.s.

The triggering of a discriminator is recorded by an associated electronic counter comprising dekatron counter tubes and capable of counting at up to 1,000 per second. An automatic muting arrangement is provided to prevent the scanning of the join of the sample sheet on the drum from being recorded.

<sup>1</sup> L. K. Wheeler and E. S. Trickett—"Measurement of the Size-Distribution of Spray Particles." *Electronic Engng.*, Vol. 25, No. 308, October 1953.

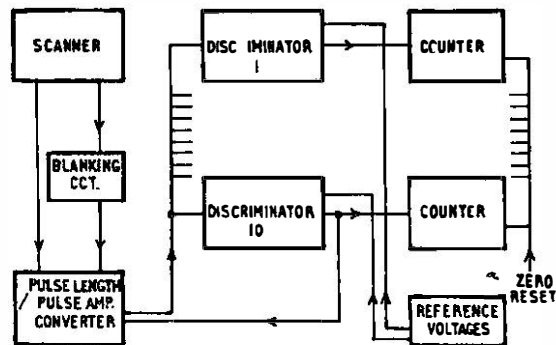

FIG. 1.—BLOCK DIAGRAM OF THE APPARATUS.

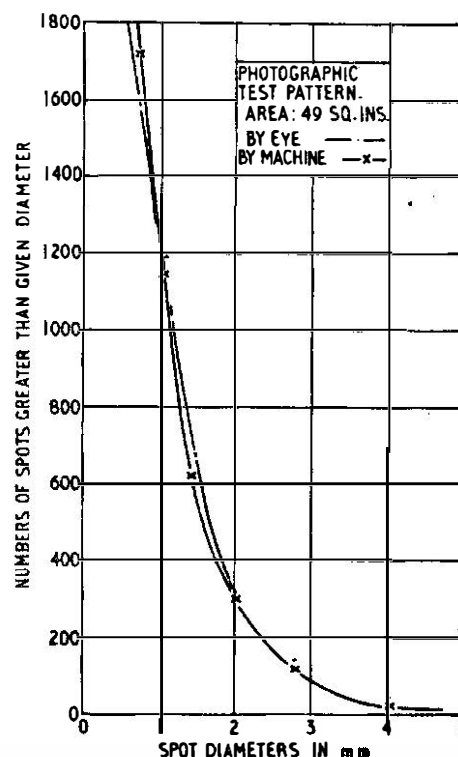

FIG. 2.—COMPARISON OF RESULTS BY MACHINE AND COMPUTATION V. VISUAL ANALYSIS.

A block diagram of the apparatus is shown in Fig. 1. Initial tests of the apparatus were made with a sample of spots of random size distribution constructed photographically. The results of analysis by use of the apparatus (which takes about 30 minutes inclusive of calculation) and by direct visual measurement are shown for comparison in Fig. 2. The agreement is quite striking, but considerably greater deviation would be expected from field samples, possibly no better agreement than within 10%. However, the great saving in time provided by the use of the analyser is a considerable advantage, and, if compared with the area-sampling technique on the basis of equal time expended, the use of the analyser produces a much more reliable estimate.

The development was carried out at Dollis Hill in co-operation with the National Institute of Agricultural Engineering, which now has the analyser in general use.

L. K. W.

# An Improved 2-ton General Utility Vehicle

G. H. SLATER, A.M.I.E.E.†

U.D.C. 656.135

This article describes improvements in the design of the 2-ton general utility vehicle which was introduced experimentally about four years ago.

## Introduction.

SOME four years ago an experimental 2-ton general utility vehicle was designed by the Post Office Engineering Department and put on trial. The vehicle offered many advantages over earlier types, including a higher payload capacity, low-loading facilities, more floor and locker space, and an improved standard of comfort for the external gang.

While the trial was still in progress, further vehicles to the same design were put into service and have proved to be a most valuable addition to the Department's motor transport facilities.

As the result of extensive experience of the experimental type under working conditions, a number of modifications have been decided upon and incorporated in the standard 2-ton utility vehicle described in the following paragraphs. The necessity for a new vehicle and the general considerations influencing its design have already been discussed in an earlier article.\*

## The New Vehicle.

The general appearance of the vehicle now standardised is illustrated in Fig. 1, which shows the vehicle fully loaded



FIG. 1.—THE NEW VEHICLE, FULLY LOADED.

with stores for an installation gang, including two 36-ft. poles and one 30-ft. pole.

As in the experimental version, the chassis is a 3-ton Karrier Low Loader fitted with twin rear wheels giving a floor height of about 3 ft. Externally the experimental and new vehicles look similar but the latter has a cab frontage of improved appearance and can readily be identified by the aluminium alloy roll shutter fitted at the rear. The metal shutter (Fig. 2) is, in fact, the most prominent of the improvements incorporated in the vehicles now going into service.

A feature of the shutter is that the facility of free access to the ladder shelf for the stowage and removal of the ladders has been retained with an unrestricted space of approx. 18 in. between the shelf and the underside of the roof rails. At the forward end of the body there is no

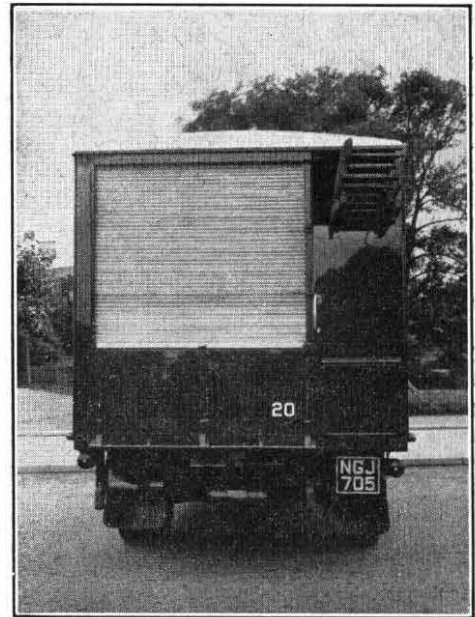

FIG. 2.—REAR VIEW WITH ROLL SHUTTER CLOSED.

difficulty in providing this space since the ladder and pole hatches are hinged on their lower edges and require no fixed guides. At the rear end, however, the off-side guide for the roll shutter presented a problem which was eventually overcome by designing a guide, the upper portion of which is hinged at a point just below the level of the ladder shelf. In the raised position, the hinged portion is locked by a bolt, thus providing two rigid guides for the free running of the roll shutter (see Fig. 3). In the lowered position, which can, of course, only be effected with the shutter rolled up, the hinged portion of the guide is secured by the same bolt to the front face of the fixed portion of the shutter guide.

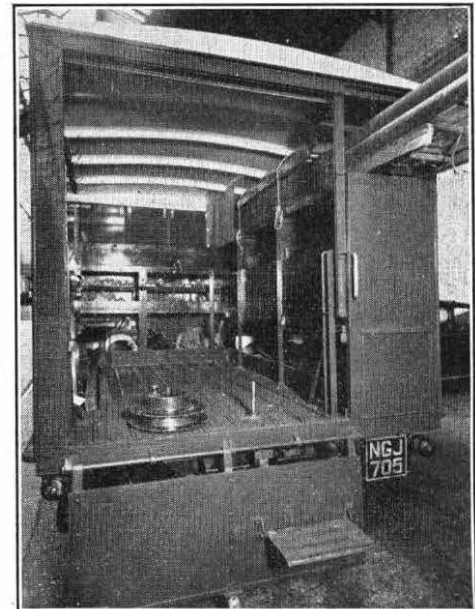

FIG. 3.—REAR VIEW WITH SHUTTER AND TAIL-BOARD OPENED.

† Executive Engineer, External Plant and Protection Branch E.-in-C.'s Office.

\* P.O.E.E.J., Vol. 42, p. 22.



To prevent damage by the inadvertent closing of the shutter when the hinged portion of the guide is in the lowered position, a spring-loaded stop incorporated in one of the supporting brackets effectively locks the shutter in the up position. The stop is automatically set clear of the shutter when the hinged portion of the guide is in the raised position.

The fitting of this shutter should overcome the criticism that the original canvas curtain gave doubtful security; it is hoped that the increased cost of the roll shutter will be more than offset by savings in the cost of maintenance on the more easily damaged curtains.

The majority of the 2-ton general utility vehicles carry long ladders which must project beyond the front of the vehicle body; consequently, an offside forward hatch is required and, for all practical purposes, this has to remain permanently open. The original vehicles were arranged with a total of three forward hatches of equal size, two of which allowed for pole carrying. On most occasions, however, it was only necessary to have open the offside hatch and it was found that, even when a full complement of ladders was in position, a comparatively large open space was left through which rain and snow could drive.

To overcome this difficulty, the forward hatches have now been arranged in four sections, thus reducing the open space immediately adjacent to the ladder pile. To close off this open space, a canvas screen has been provided, which extends from the vehicle roof to the ladder shelf, and from the forward hatch to a position about 3 ft. along the ladder shelf, for the purpose of confining rainwater and snow to the forward portion of the shelf. The screen (visible in Fig. 3) is fixed flush to the underside of the roof, and the lower edge is secured by turnbuttons to the face of the ladder shelf fence-board. The forward edge of the screen has been shaped to form a small flap which turns to meet the face of the forward hatch, where it is held in position by turnbuttons. A small flap sewn along the inner side of the screen overlaps the ladder shelf fence-board to direct water from the screen to the shelf. A stiffener in the form of a steel rod sewn into a seam near the lower edge of the screen facilitates easy rolling for stowing the screen against the roof, where it is secured by two straps.

To dispose of any water which collects on the forward portion of the ladder shelf, draining grooves have been cut into the shelf to direct the water to a drain tube.

Experience with this screen is at present somewhat limited and it may later be decided to achieve the same object with a sliding panel.

To satisfactorily stow and remove the ladders from the ladder shelf, it will now, of course, be necessary to roll up the screen and open two forward hatches: a small disadvantage compared with the improved conditions inside the vehicle.

When poles are being carried, there is no practicable alternative to leaving the front open, but, as this period is of short duration compared with the periods for which ladders have to be carried, any inconvenience from this source should be slight.

The devices for securing the ladders to the shelf have been given much consideration. Apart from the fact that the ladder pile may vary considerably in height, it is an unyielding load which needs a securing device with an unlimited range of tightening adjustment but no tendency to slip. Various types of tongueless buckles were tried, but each had disadvantages either in respect of slipping after tightening or difficulty in releasing when tightened.

Eventually a most simple device seems to have solved the problem—a length of sashline, secured to the shelf so that it cannot be lost, and having at its free end a hooked plate which can be attached to one of a set of staples secured to the side

of the body behind the ladder pile, this, in conjunction with a simple cleat attached to the front of the ladder shelf fence-board, provides a wide range of length and tightening adjustment with practically no tendency to slip.

As a possible alternative, a set of tongue-buckle straps has been designed with a spring attachment which gives the necessary range of adjustment over the distance between consecutive sets of holes in the strap. This device works quite satisfactorily and can be introduced should any unforeseen difficulties occur with the sashline.

The layout of the internal fittings, decided upon after considerable field investigation, provides a fair measure of flexibility and facilitates orderly arrangement of the stores and tools. Figs. 4 and 5 show a typical layout for a four-man installation gang.



FIG. 4.—INTERNAL FITTINGS BELOW LADDER SHELF.

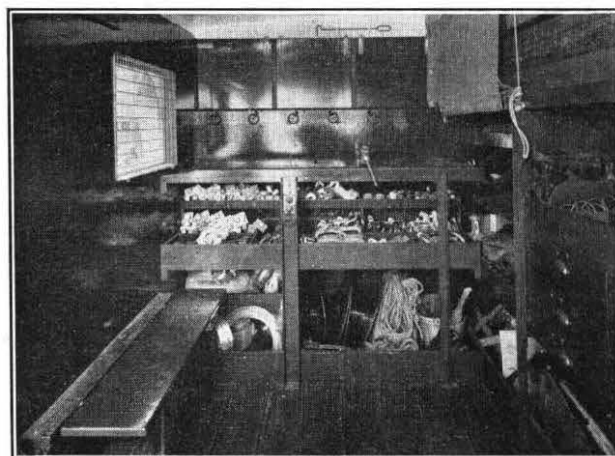

FIG. 5.—INTERNAL FITTINGS, FORWARD END OF VEHICLE.

The compartmented nest of drawers accommodates the small items of stores, such as cleats, staples, number nails, lugs, copper sleeves, etc., as well as some of the smaller tools. Each drawer can be secured with a budget lock to prevent movement when the vehicle is in motion, and a measure of rearrangement is possible with the loose partitions.

The instrument cupboard for stowing telephones, connection strips, fitter's bag, etc., is lockable, and the two sliding doors provide adequate means of access with the minimum of obstruction.

The insulator rack is removable, and for duties not requiring this facility the space can be used for other purposes by rearranging the loose partitions provided as part of the vehicle equipment.

The top of the forward rack provides an adequate work bench and a suitable position for mounting the vice; for this purpose it has been kept clear, but there is no reason why it should not be used for the stowage of stores as well.

The occasional seat on the vehicles now going into service has been reduced in length to enable a rack for stowing large coils of wire to be mounted along the nearside of the body.

The light has been moved to the nearside of the vehicle so as to better illuminate the racks on the offside without detracting from the general interior illumination.

To complete the interior body fittings, accommodation for stowing the pole guides and wiring drum spindles has

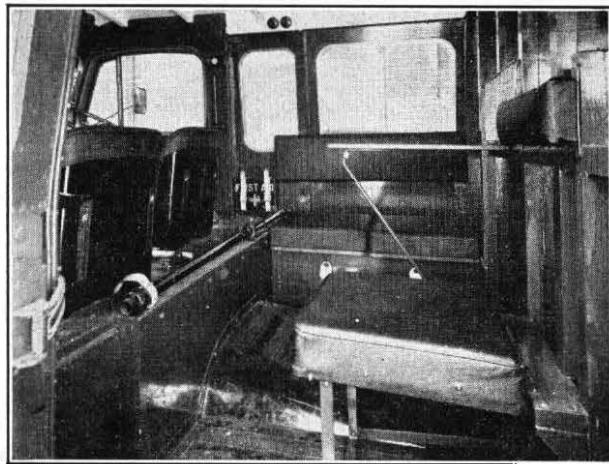

FIG. 6.—VIEW INSIDE CAB.

been arranged for by the fitting of a small rack in the space immediately behind the offside rear bolster support. This should effectively keep these pieces of equipment where they can always be found and prevent them from inadvertently being stowed away in inaccessible places.

The cab (Fig. 6), as in the original vehicles, accommodates five men. An additional rack for papers has been included and the gang's first-aid outfit is now fixed in a prominent position on the offside of the cab. The most marked improvement will no doubt be the disappearance of the engine with its rather noisy air intake filter, which has now gone in its entirety under the cab floor. The cab doors are fitted with winding windows and cylinder type door handle locks, in place of the usual type of lock with its somewhat cumbersome key.

#### Conclusions.

It is considered that the improved 2-ton general utility vehicle now going into service is a decided advance in Departmental motor transport facilities, which should ensure a fair return in increased productivity from the users. Whether retrospective action is to be applied to the large number of original 2-ton general utility vehicles to bring them up to date is a problem that will need careful consideration. Some of the improvements mentioned in this article can be introduced fairly readily, however, if decided upon.

#### Acknowledgment.

It is desired to record acknowledgments to the officers of the Motor Transport Branch concerned in the development of these improvements, and to colleagues in the Construction Branch, in particular Messrs. A. I. Campbell and W. W. Mott.

## Book Review

"Principles of Transistor Circuits." Edited by R. F. Shea. Chapman & Hall, Ltd., London. 535 pp. 475 ill. 88s.

Any book written, as this is, by staff of the General Electric Company of the U.S.A., is sure to contain matter of substance. When, in addition, the subject is part of one in which that company has made major scientific, technological and engineering contributions, something of particular importance can be expected. Moreover, while the book is the first ever on the subject and as such could have been welcomed, even if it had been nothing more than a co-ordinated summary of the articles which have been appearing in increasing numbers since the discovery of the transistor in 1948, it contains much new material, particularly about the use of junction transistors.

After a brief introduction to the physics of semiconductors and transistor action, transistors are considered as low-frequency elements and as amplifiers. Chapters on inter-stage couplings in amplifiers and methods of stabilizing bias currents are followed by one detailing the operation of power amplifiers. A brief chapter only is devoted to D.C. amplification, in which use transistors do not show of their best. High-frequency operation, a subject of much importance is more fully considered. Oscillators receive only a brief mention. Two chapters, one on duality and the other on matrix methods, attempt to provide techniques of circuit design and analysis; the second, with an Appendix giving a brief resumé of matrix algebra, should prove particularly useful. Feedback amplifiers are then discussed, particularly in relation to the variation of current gain,  $\alpha$ , with frequency,  $f$ , which is more complex than the often-used expression  $\alpha = \alpha_0 / (1 + j/f/f_0)$ , where  $\alpha_0$  is the L.F. value of  $\alpha$  and  $f_0$  the frequency at which  $\alpha$  has fallen 3 db. below  $\alpha_0$ . The transient performance is next deduced from physical considerations and a more elaborate equivalent circuit

proposed which takes account of the findings. The important point is made that the diffusion of minority carriers through the base of a junction transistor may be represented by a minimum phase-shift network.

Large-signal operation and trigger circuits are dealt with, but, perhaps too briefly, in view of their widespread possibilities in computing circuits and the large amount of attention given them in the journals. The last three chapters deal with noise—an important limitation in some applications—with diodes and some more complex associated semiconductor elements and finally with methods of measuring small signal parameters.

The general presentation is good and the bibliography very extensive.

The more detailed and up to date any book on transistors sets out to be, the more rapidly will it appear out of date. It cannot, unfortunately for the editor, be long before this excellent book requires revision. Improved and new forms of transistor, with much increased bandwidths, and new basic trigger circuits will alone open up new fields of use. In the meantime, however, all serious users of transistors should welcome the book; if its high standard is maintained in the many books on transistors which the years will bring, the way of the student and circuit designer alike will be much eased. But it is hoped that the high price will not also set a standard for others.

J. R. T.

#### SHORTER NOTICE

"Transients, Negative Feedback and Stability—Theoretical Principles and Applications" (in German). Johannes Peters. Springer-Verlag, Berlin. 181 pp. DM27.

An up-to-date presentation of the fundamentals of transmission technique and allied problems in electrical communication, including television and electro-acoustics, with possible applications to control technique.

# New Accommodation for the Telephone Branch Circuit Laboratory

U.D.C. 727.5:621.395

M. MITCHELL, M.B.E., B.Sc.(Eng.), A.M.I.E.E.  
and P. D. CORBY, B.Sc.(Eng.), A.M.I.E.E.†

The authors give an account of the accommodation of the Telephone Branch Circuit Laboratory in its new location at Armour House, E.C.1, accommodation which replaces that in King Edward Building occupied by the Laboratory for a period of nearly 30 years. The layout and purpose of the various rooms are described briefly.

## Introduction.

THE Telephone Branch Circuit Laboratory, which was established in King Edward Building, E.C.1, in 1924, has been described in earlier articles in this Journal.<sup>1,2</sup> Over the years, a number of changes have occurred in the type of work which the laboratory is required to carry out, and these have been met by re-arrangements and extensions of the accommodation. Thus, the last 20 years have seen not only a steady increase in work on normal circuit testing but considerable developments in the field of tests on mechanical performance, in the photographic and optical work necessary, in electrical measurements requiring techniques not previously available to the circuit testing groups and in the workshop facilities required. At the same time the staff has increased steadily to a total figure of approximately 120.

In recent years the limit had been reached to the improvements which could be effected in the existing accommodation without a major re-arrangement involving a complete and prolonged cessation of the normal work of the laboratory. At the same time, the Engineering Department had been under increasing pressure, from the London Postal Region, to vacate the accommodation which, it had always been understood, was occupied on a temporary basis only. New accommodation for the circuit laboratory was therefore sought and, after considering various alternatives, that offered in Armour House, St. Martin's-le-Grand, E.C.1, was accepted as suitable in 1950.

The planning of the layout of the new laboratory was then put in hand, provision being made for the changes in the nature of the laboratory's work, already referred to, which had occurred gradually over the years. By July, 1953, the necessary building alterations were approaching completion and detailed preparations for the actual removal of the laboratory were made. The removal took place during October 1953 and the new premises were formally opened by the Engineer-in-Chief on 15th December, 1953. This article describes the new accommodation and the facilities which the laboratory now has at its disposal.

## General Layout of Accommodation.

The general layout of the new accommodation is shown in Fig. 1; it will be seen that the main testing laboratory occupies a central position on the ground floor and that round it are disposed rooms providing most of the remaining laboratory facilities. These include a smaller laboratory (designated the special measurements room and equipped to carry out tests using techniques or power supplies not available in the main laboratory), the construction group (comprising a relay assembly shop, the construction shop and the mechanics' and carpenter's workshop) and the laboratory stores. Also located on the ground floor are the office accommodation; a room housing certain electronic equipment and also performing the function of a projection

room for the study of high-speed films; and a dark-room for the development of oscillograms.

The battery room and power room supplying the laboratory are located on the sub-ground floor below the special measurements room and also on this floor there is a bulk store room for the storage of racks and other large items of equipment not required in everyday use.

On the first floor of the building, easily accessible from the remainder of the accommodation, are located rooms for the photographic and optical measurements side of the laboratory's work. This accommodation includes a photographic studio, an optical and physical measurements room, a chemical store room, and associated dark-rooms and print-drying room. The staff dining room, with a small but well-equipped kitchen, and a filing and reference room complete the accommodation on this floor.

The total floor area occupied is 16,400 sq. ft., compared with 13,500 sq. ft. formerly occupied in King Edward Building.

Subsequent paragraphs describe the detailed layout and facilities of the different portions of the accommodation described above.

## Main Laboratory Accommodation.

*Layout of Apparatus Racks and Benches.*—A general view of part of the main testing laboratory is shown in Fig. 2. The layout of apparatus racks and benches will be evident from this in conjunction with the plan in Fig. 1. The laboratory has retained its existing organisation into testing groups, each under an Assistant Engineer, with a staff of Technical Officers and Technicians; but whereas formerly the apparatus racks for these testing groups were arranged round the perimeter of the laboratory they are now, in general, disposed in parallel bays. The area occupied by each testing group is thus more clearly defined and self-contained than formerly, and the total space available for apparatus racks has been considerably increased. It will be observed from Fig. 1 that the laboratory is of irregular shape and this has prevented the adoption of a completely rectangular layout. The positions of racks and benches have also been dictated in some instances by the presence of a number of supporting pillars forming part of the building structure.

The main laboratory has four entrances giving access by single doors from the office and the stores counter and by double doors from the special measurements room and the construction shop. Those from the construction shop are also of double height to permit easy movement of complete racks into the laboratory.

*Distribution of Battery Supplies and Common Services.*—Battery supplies enter the laboratory near the door leading to the special measurements room (see later description) and these terminate on a rack from which they are fed to bus bars taken round the laboratory between the supporting pillars referred to above. From the bus bars feeds are taken by cable to panels provided on each rack. The supplies fed round the laboratory in this manner are  $-50V$ ,  $-24V$ ,  $+50V$ , and earth and, in addition, a  $-50V$  supply from a constant voltage machine is similarly distributed but is at present fed to only one rack. The main 50V supply has

† The authors are respectively, Senior Executive Engineer and Executive Engineer, Telephone Development and Maintenance Branch, E.-in-C.'s Office.

<sup>1</sup> B. O. Anson, M.I.E.E., "Engineer-in-Chief's Automatic Training School and Circuit Laboratory", *P.O.E.E.J.*, Vol. 18, Part 2, July 1925.

<sup>2</sup> R. W. Palmer, A.M.I.E.E., "The Post Office Circuit Laboratory", *P.O.E.E.J.*, Vol. 29, Part 7, April 1936.

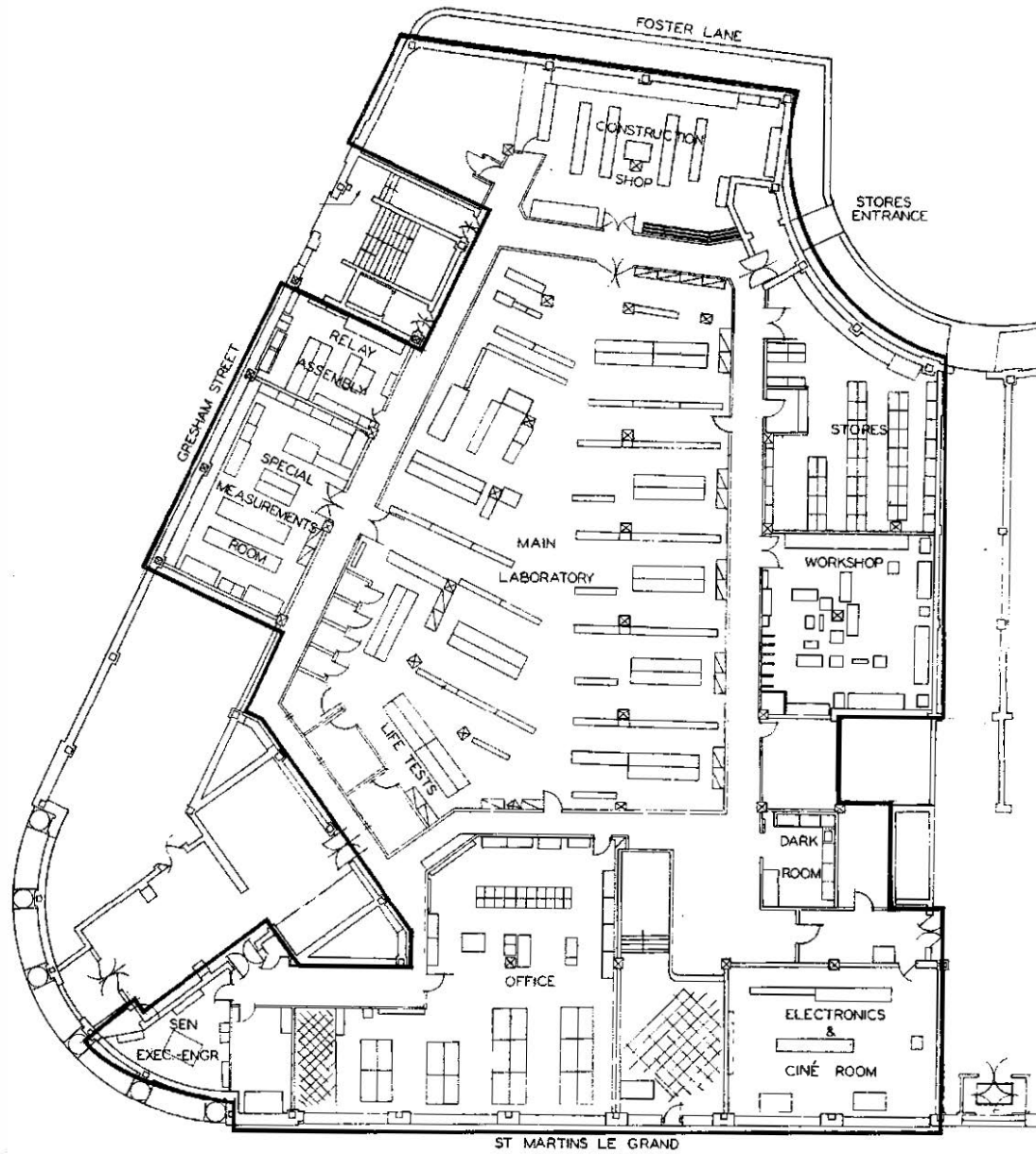

(a) GROUND FLOOR.

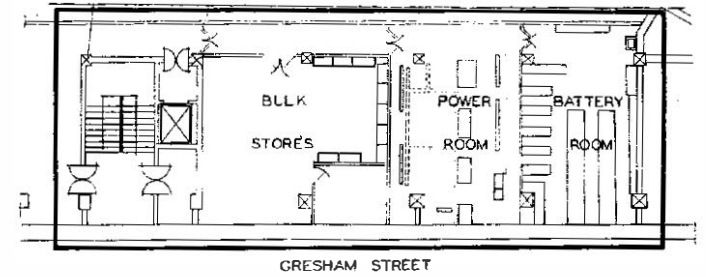

(b) LOWER GROUND FLOOR.

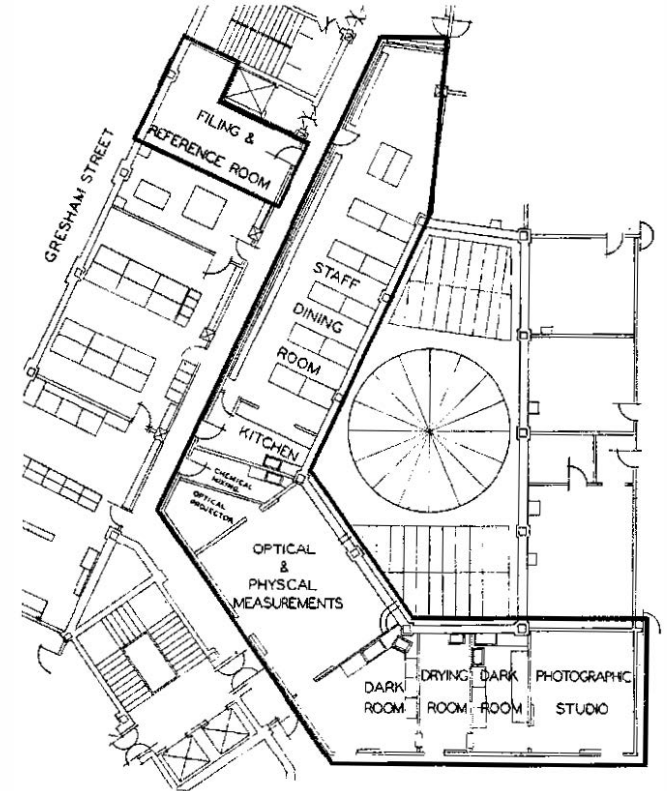

(c) FIRST FLOOR.

FIG. 1.—LAYOUT OF THE NEW ACCOMMODATION FOR TELEPHONE BRANCH CIRCUIT LABORATORY.





FIG. 2.—PART OF THE MAIN TESTING LABORATORY.

been designed to give a voltage drop not exceeding 0.1V at 50 amps. load, the normal load of the laboratory being 15-20 amps.

For laboratory tests it is frequently necessary to work at the permitted extremes of battery voltage (e.g. 46V and 52V) and these are obtained from the normal supply by providing nickel-iron cells. These cells are mounted in boxes on each rack, and tumbler switches associated with them enable 1 to 4 cells to be brought into circuit either aiding or opposing the main battery supply as required. This arrangement has obviated the need to provide separate feeds for "adverse" voltages and has resulted in a considerable economy in bus bars.

Tone and pulse feeds are distributed in troughing to four points in the laboratory.

*Allocation of Racks to Circuit Testing Groups.*—There is a broad functional division between the various circuit testing groups, the aim of which is to permit a certain degree of specialisation whilst preserving flexibility of staff. The present functional division is as follows:—

- (a) Manual Systems
  - Director and Non-Director Systems
  - Subscribers' Apparatus
  - P.A.B.X.s
  - Artificial Traffic Equipment
- (b) U.A.X.s
  - Shared Service
  - Soldering and Wiring
- (c) Pulsing
  - Testers
- (d) Routine Test Pulse Conditions
- (e) D.C. Signalling Systems
  - Electronic Circuit Elements
  - Observation Equipment
- (f) A.C. Signalling Systems

(g) Routers  
Cordless Switchboard System

These testing groups have each from 26 ft. to 42 ft. of apparatus racks 7 ft. in height available for laboratory tests. Generally, however, relay sets and selectors under test have to be associated with standard items of equipment and, to facilitate this, certain of the rack space is used to accommodate director and non-director equipment and D.C. and A.C. signalling systems. The verticals of the apparatus racks can readily be moved to new positions, allowing considerable flexibility in accommodating apparatus shelves of different lengths. The laboratory also houses U.A.X.s 12 and 13, components of a U.A.X. 14, a P.A.B.X. No. 1, a sleeve control switchboard and a P.M.B.X. 1A. The relay sets and switches associated with the cordless switchboard equipment have been retained and a standard router rack of the RT 1000 type is about to be acquired.

*Mechanical Life Test Rooms and Cubicles.*—Three of the laboratory testing groups are concerned with mechanical performance and life tests on relays and selectors and again there exists a functional division between them, one group dealing with relays, another with uniselectors and the third with two-motion selectors. These three groups have bench space allotted in one section of the main laboratory and adjoining it are three rooms and four cubicles for the mechanical performance tests. These rooms are equipped with racks on which a number of life tests can proceed simultaneously and the four cubicles are intended for individual life tests or for tests for which special conditions—for example, a dusty atmosphere—are required.

The walls of the rooms and cubicles are lined with sound-proofing material and alarms are displayed above the doors to indicate when faults arise on the equipment under test.

A view of this portion of the laboratory including the life



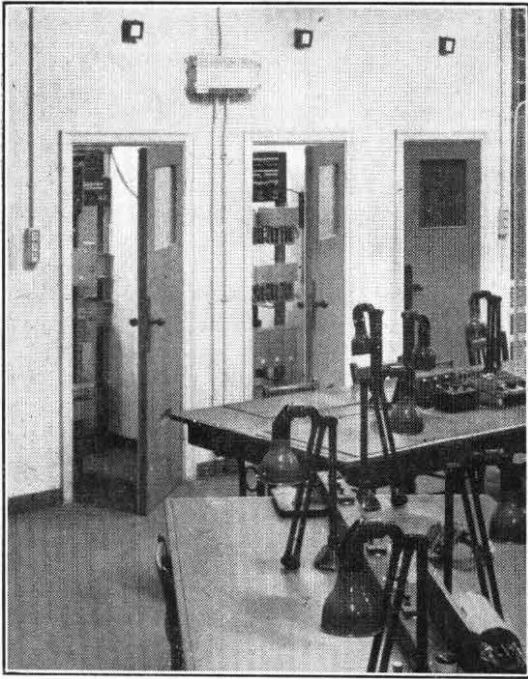

FIG. 3.—CUBICLES FOR MECHANICAL PERFORMANCE LIFE TESTS.

test cubicles is shown in Fig. 3.

*Lighting.*—The general lighting of the laboratory is provided by 80W fluorescent fittings to give a general illumination of 10 lumens per sq. ft. at bench level. In addition, all benches are provided with "Mek-Elek" fittings to give local illumination for adjustments. The laboratory is situated below a light well of the building and natural illumination is provided by three large roof lights, supplemented by borrowed light from half-glazed partition walls on two sides of the laboratory.

#### *The Special Measurements Room.*

The facilities provided in this room include a bench with self-contained supplies from  $-150V$  to  $+250V$  D.C. in 50V steps, and 230V and 6.3V A.C. On a transmission test rack behind this bench is a valve tester for checking static or dynamic characteristics, an impedance bridge, a Ryall-Sullivan Oscillator, a D.C. bridge and amplifiers and attenuators. For tests under extreme conditions of temperature a refrigerator and an oven are available.

The special measurements group is also responsible for the calibration and maintenance of the instruments used by other testing groups and several useful aids to this work have been developed, either by or for the laboratory. They include a calibration box for voltmeters and ammeters with current ranges up to 12 amps. and voltage ranges to 400V; an electronic time interval measuring set which incorporates an 80 kc/s drive circuit giving an accuracy of 1/80 of a millisecond; and a frequency dividing circuit using multicathode tubes which converts a sinusoidal input frequency into a pulsing output of 1/100 of the input frequency. This group has itself been responsible for the development of new testing techniques for use generally in the laboratory and a recent example of this side of their work is the provision of a wiper-to-bank contact resistance recorder for use in conjunction with life test equipment.

It will be noted from Fig. 1 that the special measurements room is located directly above the power room. The battery supplies from the latter are all terminated on a rack in the special measurements room and those required in the main laboratory are then fed under the intervening corridor to terminate on the rack referred to previously.

#### *Accommodation for Photographic Work and Physical and Optical Measurements.*

*General Layout.*—The physical measurements room and the photographic studio on the first floor have dark-rooms associated with them which lie on either side of the print-drying room and there is a third dark-room on the ground floor near the main laboratory for the development of oscillograms taken during investigations. Sliding doors, with dark curtains where a light trap is necessary, and exhaust fans for ventilation, are fitted in all these rooms.

*Photographic Studio.*—The studio contains two cameras, both quarter-plate, one for general photography and the other a monorail camera for bench work involving greater magnification. A selection of interchangeable lenses increases the range of subjects for which each camera can be used. The room is equipped with movable overhead batten lighting in addition to mobile floor standard lamps of adjustable focus. A special A.C. mains supply is available for the extra lighting needed when high-speed cinematography is used. A horizontal enlarger with an adjustable screen is set up on a bench in the adjacent dark room.

*Physical and Optical Measurements Room.*—The equipment provided in this room includes a horizontal profile projector housed in a recess at one end of the room. The purpose of this instrument is to project enlarged profiles of small objects on to a screen. Black curtains and "safe" lights are provided for use when photographic reproductions are required. For other inspections and measurements a Vickers hardness tester, binocular and metallurgical microscopes, vernier calipers, dial gauges and micrometers are available.

*Dark Rooms, Print-Drying Room and Chemical Store-Room.*—Each dark room is provided with three lead-lined sinks arranged in cascade and these incorporate a simple siphoning arrangement to provide a regular flushing action from one sink to the next for efficient washing of prints. Additional lead-lined sinks are provided for hypo and, in the case of the ground-floor dark-room, for developer also.

The first-floor dark-rooms are each provided with a light-proof hatch—permitting access from only one side at a time—to the print-drying room which lies between them. This drying room contains two drying and glazing machines. The dark-room associated with the physical and optical measurements room contains also a document-copying box which is used for the reproduction of sketches for reports and other material for use in the laboratory.

The ground-floor dark-room is used for the development of oscillograms, the majority of which are taken in the main laboratory where three Duddell oscillographs are in regular use.

The chemicals used in the photographic work are stored in a separate room provided with ample shelf accommodation, a lead-lined bench, a sink and a chemical balance.

#### *The Electronics and Ciné-Projection Room.*

This room at present houses the electronic traffic analyser, for the maintenance of which the laboratory is responsible, and will shortly also contain an electronic P.A.B.X. being developed to provide the laboratory's communication requirements.

The room is provided with black-out curtains to permit its use as a ciné-projection room for the study of high-speed films, of which the laboratory makes extensive use.

#### *Accommodation for Construction Work.*

*Relay Assembly Room.*—The purpose of the relay assembly room is to supply any existing or newly coded relay on demand and an extensive stock of relay piece parts is held. A relay adjustment bench is provided, incorporating six positions, each equipped with a 50V battery supply and

bench lighting. Facilities are available for winding coils and one of the coil-winding machines can be run at a very slow speed which proves useful when faulty coils are being investigated.

**Construction Shop.**—The lighting in this room is particularly good as, in addition to large windows for natural lighting and fluorescent tubes for general illumination, fluorescent lighting fittings are provided on the wiring benches themselves. A low wooden platform has been fitted along one wall to support a forming board at an angle against the wall for use when large forms are being made. This enables the work to be carried out by one man instead of two, as has been the case previously. The wire used for these forms is wound on spools on mobile racks. The height of the platform is such that a Stand, Testing No. 22 is raised to a convenient height for wiring when placed on it. Both steel and wooden batten-type shelving have been provided for the stores required on current jobs and completed items awaiting despatch. The doors in this room and those opposite into the main laboratory are 12 ft. 6 in. high, in two sections, to permit racks to be transported in the vertical position from the construction shop to the laboratory for testing. A special rack transporter has been designed and built for this.

The varied nature of the work carried out includes the construction of prototype testers, relay sets for use by the testing groups, field trial equipment and equipment for the defence services.

When major reorganisations of equipment are necessary either on the permanent installations in the laboratory or to items undergoing test, the staff to do this work is provided from the construction shop.

**Mechanics' and Carpenter's Workshop.**—The general arrangement of this room is shown in Fig. 4.

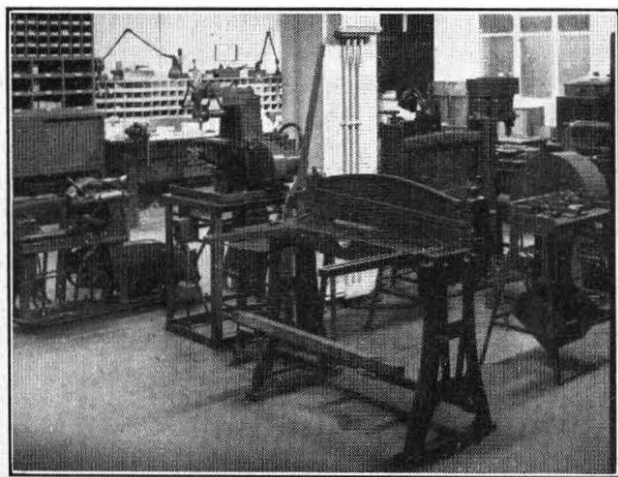

FIG. 4.—MECHANICS' AND CARPENTER'S WORKSHOP.

In the planning arrangements have been made to obtain the best use of rather limited natural lighting and for this reason the benches are as near as possible to the window and the racks for wood and metal storage are placed along the two walls remote from the window. The machines, with the exception of the electric welding plant and the brazing hearth which are in two corners of the room, are grouped round a central pillar and include a mechanical hacksaw, a Myford ML 4 lathe, two pillar drills, a milling machine, a high-speed grinder, a guillotine, two box benders and a metal-strip cutter. Careful consideration has been given to the individual positions of these machines, e.g. the hacksaw is so placed that lengths of material too long for the metal store can be cut as they come into the workshop, and the machines used by the carpenter are nearest to his benches.

The fluorescent lighting is anti-stroboscopic and individual lights are fitted to each machine for local illumination. The welding bench can be screened when in use to prevent eyestrain to others in the room.

#### **Power Supplies.**

**Battery Room.**—The battery room has the standard finish of acid-proof paint on the walls and acid-proof tiles set in asphalt on the floor. The batteries stand on brick plinths 30 in. high to permit easy maintenance. The tops of these plinths are concrete and, for protection from acid spray, the whole structure has been coated with bitumen paint and the tops have been given an additional coating of paraffin wax. The battery containers stand on wooden battens which have been painted with acid-proof paint.

The two main 50V batteries are each of 300 Ah capacity and are used on a charge/discharge basis. For the life-testing equipment two float-charged 50V batteries of 10 and 20 Ah capacity are used. Two 24V 75 Ah batteries provide a "silent" supply to the special measurements room and the main laboratory respectively. The positive battery supply to the laboratory is provided by one 10 Ah capacity battery while four similar batteries supply 50V and 150V to the special measurements room. For the maintenance and charging of portable batteries a lead-lined bench, a sink with mains water, and a charging panel have been provided.

**Power Room.**—Four machines, a motor-generator set, a constant voltage generator (used by the pulsing group) a variable frequency alternator and a commutator-type ringing machine are mounted in line in the centre of the room. Facing these and parallel to them is the switchgear for the battery supplies, along the wall nearest to the battery room, and on the opposite side of the room are the tone and pulse supply racks which feed the laboratory. A U-link panel permits different sources of tones to be used, e.g. ringing tone is available from either an inductor tone or commutator-type ringer and V.F. tones are available from either a machine or oscillators.

Two rectifier units in line with the main switching panel supply 50V for the main life test load, and one giving 230V supplies the variable frequency alternator which has an output of 1.035 kVA at 230V nominal at a frequency of from 5 to 75 cfs. The 230V rectifier unit also supplies the special measurements room and one of the coil-winding machines in the relay room. All cables from this room pass to the special measurements room, which is immediately above, and from there they are distributed to other parts of the accommodation.

#### **Stores.**

The stores accommodation is at the rear of the building with easy access from Foster Lane. The door to the stores counter faces a similar door to the main laboratory across the corridor, giving easy access for those employed in the laboratory. Most of the stores are accommodated on steel racks with adjustable shelves. The stock held includes various non-Rate Book items which the special nature of laboratory work requires and the number of counter transactions is approximately 200 per day.

A special room has been allocated on the lower ground floor for the storage of larger items of equipment such as apparatus racks, relay set and selector shelves and cable. Items of equipment such as relay plates in excess of day-to-day requirements are also held in this room, and steel racking with adjustable shelves has been provided for them.

#### **Office Accommodation.**

The general office provides accommodation for three Executive Engineers, 12 Assistant Engineers and a clerical

staff of three. The layout of the room permits all the occupants to be seated conveniently near large windows on the St. Martin's-le-Grand frontage of the building, that part of the room remote from the windows being occupied by filing presses and cabinets. A separate office is provided for the Senior Executive Engineer.

#### *Welfare Accommodation.*

The welfare accommodation comprises a room on the first floor for use as a staff dining and recreation room for the technical officers, technicians and youths, totalling some 90, employed in the laboratory. Adjoining it, and fitted with a service counter, is a small kitchen, the equipment of which includes a gas cooker, a refrigerator and a "café-set" for the provision of tea and coffee.

#### *Removal to the New Accommodation.*

It was necessary for the removal to take place with the least possible interference to normal laboratory testing and construction work, and a programme covering the removal of each section of the laboratory was drawn up with this in mind. When the necessary building alterations were nearing completion steel verticals required for the construction of racks in the new laboratory were recovered from King Edward Building, being replaced by temporary racking where necessary. The new racks were built mainly of recovered material, this work being carried out by the Power Section of the London Telecommunications Region. The King Edward Building Laboratory bus bars have also been used again, being recovered at an early stage of the removal and replaced temporarily by cabling.

The actual removal of all laboratory staff and apparatus took place between the 6th and 27th October, 1953, the sequence of removal being as follows:—

- Mechanics' and Carpenter's Workshop
- Construction Shop
- Relay Assembly Shop
- Photographic and Optical Measurements Group
- General Office, Senior Executive Engineer's Office, and certain Circuit Testing Groups
- Remainder of Circuit Testing Groups
- Special Measurements Group
- Mechanical Performance Testing Groups
- Stores

By 30th October the recovery of racks, life test cubicles and batteries in King Edward Building was complete and the accommodation handed over to the London Postal Region.

The smooth progress of the removal was facilitated, not only by the co-operation and enthusiasm, at all levels, of the laboratory staff, but also by the very helpful assistance received from the Power Section, London Telecommunications Region, and the South Postal Engineering Section, London Postal Region.

#### *Conclusion.*

The circuit laboratory now has better accommodation, with layout and facilities planned in advance. It therefore looks forward with increased confidence in its ability to play its part in the technical developments of the future.

## **Book Reviews**

"Industrial Electronics." R. Kretzmann. Philips Technical Library. Distributed by the Cleaver-Hume Press, Ltd., London. 236 pp. 266 ill. 25s.

Because the author considers that some industries have been slow to make use of applied electronics, he has addressed his book primarily to works engineers engaged on production, while hoping that it will also serve as an elementary introduction to his subject—limited aims which must be remembered in assessing the book. It is in two parts. The first, of about 80 pages, describes the tubes used and their basic circuits. Only brief outlines of vacuum tubes, gas-filled rectifiers, ignitrons, photocells, cathode-ray tubes, etc., are thus possible. Some are adequate, others must be supplemented by reference elsewhere.

The remainder of the book deals with specific electronic equipments, many of whose descriptions should interest a wide range of readers. Several familiar electronic relays, some timers and one counting circuit are adequately described. The importance of equipment for rectification, the control of the speed of motors, the control of welding and the radio-frequency inductive heating of metals and capacitive heating of dielectric materials is reflected in relatively detailed descriptions. Although the reader is assumed to be familiar with practice in several diverse fields, the many waveforms included will help those who are less well informed to gain valuable understandings.

The general presentation and the English text are very good; a flavour of advertising, more properly expected in a good technical catalogue, is present but need deter no one. About one-half of the photographs, including several full page ones, could, with advantage, have been omitted to make room for longer descriptions. Something more might have been said of electronic measuring aids, and it is surprising that the amplifier of the only oscilloscope described is A.C. coupled, i.e. is not suitable for presenting very slowly changing signals.

J. R. T.

"Electrical Installation Work." T. G. Francis, B.Sc., M.I.E.E., M.I.Mech.E. Longmans Green & Co. 250 pp. 237 ill. 12s. 6d.

The preface says "The book has been written to assist those engaged in electrical installation who desire to learn something of the technical side of their work." It goes on to give sound advice to the reader to enrol in courses leading to City and Guilds certificates.

The first half of the book is devoted to installation work and although it might be argued that the treatment is largely practical, it has the merit that the student should absorb quite a number of technical pills under the interesting coating of practical detail. The I.E.E. Regulations have been inserted in the text in an effective way, so that the student can appreciate the principles underlying these regulations. A wireman should find this part of the book of considerable value.

One or two minor mistakes illustrate the need for extreme care in writing for students beginning their studies. Some reference to portable tools in the chapter on earthing would be an advantage in view of the high position these occupy in the accident records. The author's confidence in water pipes as earth connections may be misplaced in localities where non-metallic water mains are in use.

The second half of the book is entirely different. The chapters deal with illumination, electric heating, direct current machines, alternating current machines, primary cells, secondary cells, electric bells, tariffs and telephones in that order. The author appears to have overlooked the transformer.

All the subjects are covered in 107 pages, minus the space occupied by 105 figures (telephones are dealt with in 8 pages). The treatment can only be superficial in the extreme and the value of the matter is therefore doubtful. The voltage formula for a generator is reached after two short paragraphs; the words that E.M.F. stand for could not be found anywhere and electro-magnetism is not dealt with until the chapter on bells where it is explained in six lines.

A. E. P.

# An Application of the Magnetic Amplifier to Routine Testing of Junction Circuits

M. C. STONE†

U.D.C. 621.395.365:621.318.42

This article describes an application of the magnetic amplifier as a means of testing for faulty line conditions on junction circuits. A method of checking conditions on the control wire of battery-tested junction circuits is also described. As the elements are incorporated in routiner circuits which are well known, the complete routiner circuit is not described, but sufficient information is given for appreciation of the method of applying the magnetic amplifier.

## Introduction.

TESTING by a routiner for faulty conditions on loop-dialling junction circuits has been done hitherto by connecting a high-resistance relay across the line at the outgoing end. This method permits testing for continuity and polarity only. The method of testing described later increases the scope of testing, detecting contact faults up to 500 ohms resistance or coils of line relays which develop high or low resistance, in addition to the normal continuity test. In the circuit described the power available for fault detection is insufficient, without amplification, to operate a standard relay. A prototype routiner using a thermionic valve type of amplifier, incorporated in the new circuit, is in service and demonstrates the advantage of the new testing method. Because the power available for fault detection is obtained from the exchange battery in series with the junction line, having relatively low impedance, the magnetic amplifier is more suitable than a valve circuit. Furthermore, it requires negligible maintenance.

## General Description.

Two junctions completing a "bridge" arrangement are used for making a test; the first, termed the "reference junction," is used throughout the series of tests on junctions to one exchange. Full automatic start-and-stop facilities are provided, permitting tests during periods when traffic is at a minimum. The circuit is arranged for use with the docket-printing machine,<sup>1</sup> although, in view of the simple nature of the tests, the new type routiner<sup>2</sup> is not adopted.

The schematic arrangement for testing is shown in Fig. 1, junction A being the reference junction. With the

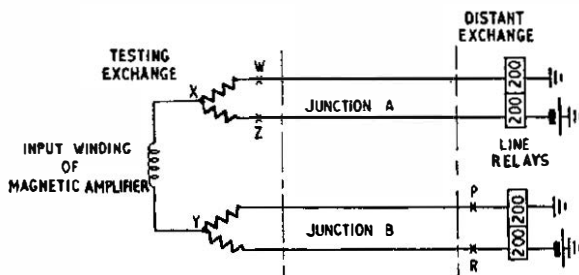

FIG. 1.—CONNECTION OF JUNCTIONS FOR TESTING.

junctions looped at the outgoing end, the voltage at points X and Y will be  $E/2$  when  $E$  is the main battery voltage at the distant exchange, and each of the junctions is balanced for resistance and leakage. A fault on any wire will cause a variation in the potential at X or Y, and when the voltage between these points exceeds a certain value a fault will be indicated. The routiner is calibrated normally to detect a voltage of 0.3V. Faults most difficult to detect are contact-to-earth at point P or contact-to-battery at point R, as these merely vary the resistance of the normal circuit condition. The routiner has been designed to detect faults

of this nature up to 500 ohms resistance.

More stringent tests could be made, but a limit is set by the following consideration. An unbalance of resistance in the coils of the terminating relay will affect the potential at point X or Y and, as tolerances under conditions of bulk manufacture must be accepted when testing, the limit mentioned above will not reject an unbalance of 20 ohms when testing to line coils of 200 ohms. On a short junction the unbalance produces the greatest effect and this has been limited by the addition of padding resistors. For ideal testing conditions the reference junction should have perfect balance.

## Sequence of Testing.

The sequence of testing under automatic control is as follows:

1. Following receipt of a start signal from the docket machine control the routiner access switches are stepped to the first two junctions of the route to be tested and a start docket is printed by the docket-printing machine, including details of the first circuit.
2. The reference junction is tested for busy, continuity of the line and P-wire, and correct polarity, using a high-resistance relay and rectifier element in series with the line (continuity of the P-wire is not tested on earth-testing circuits).
3. Circuit conditions are simulated within the routiner to check correct performance of the magnetic amplifier.
4. The first non-reference junction is extended to the routiner test circuit and tests for busy, continuity and polarity are made in a similar manner as for the reference junction.
5. The two junctions are connected as shown in Fig. 1 with the reference circuit open at point Z. At point X the P.D. to earth is thereby reduced, producing a current in the input winding of the magnetic amplifier. A relay associated with the magnetic amplifier output is thus operated.
6. Operation of the relay restores the circuit at point Z and, when no fault exists, the voltage at points X and Y become  $E/2$  approximately. If the voltage difference at these points does not exceed 0.3V the relay releases. The sequence of operating and releasing the relay constitutes a positive test.
7. Tests 5 and 6 are repeated with the input leads to the amplifier reversed and with the reference junction disconnected at W instead of at Z. As explained later, the magnetic amplifier is unidirectional and, as different types of faults may raise or lower the potential at X or Y, two tests are essential.
8. The remaining junctions of the route are in turn associated with the reference junction, tests 4 to 7 being repeated.
9. When the whole route has been tested the routiner steps to the reference junction of the next route; tests 2 and 4 to 8 are repeated.

Any failure during testing is recorded automatically on a fault docket showing details of the circuit number and nature of the failure; the routiner steps to the next circuit after recording the fault. If the reference junction is con-

† Senior Executive Engineer, Telephone Development and Maintenance Branch, E.-in-C.'s Office.

<sup>1</sup> P.O.E.E.J., Vol. 45, p. 115.

<sup>2</sup> P.O.E.E.J., Vol. 44, p. 147.



cerned the letter R is added to the printed details, testing on the route is abandoned, and the routiner steps to the next route to recommence testing.

Testing continues until a stop signal is given from the docket machine control circuit; the route under test is completed and a stop docket is printed with details of the last circuit tested.

### Magnetic Amplifier Circuit.

A simple explanation of the application of the magnetic amplifier to the circuit used in the routiner is given in conjunction with Fig. 2. The amplifier unit has four wind-

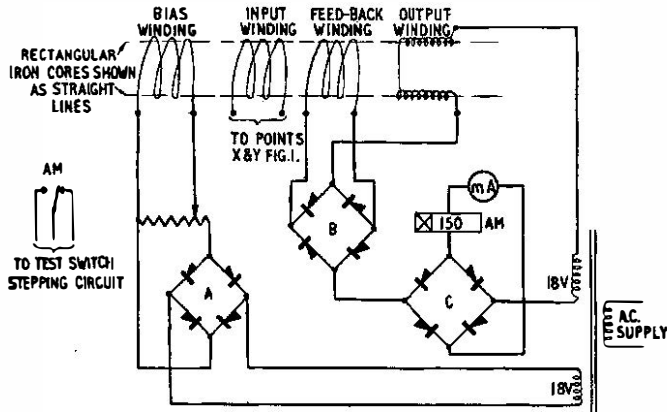

FIG. 2.—SIMPLIFIED CIRCUIT OF MAGNETIC AMPLIFIER.

ings arranged on a pair of cores each having a closed magnetic circuit (shown as straight dotted lines for simplicity). The output winding can be considered as an A.C. choke, connected in a manner which prevents A.C. voltage at the fundamental frequency of the source of power being produced across the input terminals. Application of a D.C. voltage to the input winding produces a magnetising effect in the cores, increasing to saturation as the voltage is increased. This lowers the impedance of the output winding and an increase of current in the output circuit is supplied by the mains transformer. The current is fed through a rectifier network C from which relay AM is operated. As the increase in current is gradual and contains a ripple from the rectifier output, relay AM is provided with a slug to prevent chattering at the point of operation.

A simple arrangement of input and output windings will operate as an amplifier with the input voltage applied in either direction, but the gain (i.e., change of output current/change of input voltage) is too small in this particular application to operate relay AM. With the addition of a positive feed-back winding an increase in output current, rectified by network B, augments the magnetising effect of the cores; further reduction in the impedance of the output winding increases the overall gain. The feed-back winding is positive only to voltage applied in one direction to the input winding, making the amplifier unidirectional. Maximum sensitivity is obtained when working on the steep portion of the magnetisation curve; the bias winding provides sufficient current via rectifier A to raise magnetisation so that a change of input voltage will produce the maximum effect.

For calibration a potentiometer in the bias circuit is set in conjunction with a milliammeter connected in series with relay AM, input voltage at working values being simulated by keys provided on the routiner. The current values obtained normally in relay AM are of the following order:

- Standing current (no voltage at input terminals) 4 mA.
- Saturate condition (maximum voltage at input) 45 mA.

Critical operating current (release current of relay AM) . . . . . 9 mA.

### P-wire Testing of Battery-Tested Circuits.

When stepped to a busy junction the routiner waits for a period, usually three minutes, to permit testing to proceed if the circuit becomes free. A typical P-wire circuit for battery-tested junctions is shown in Fig. 3, with the main

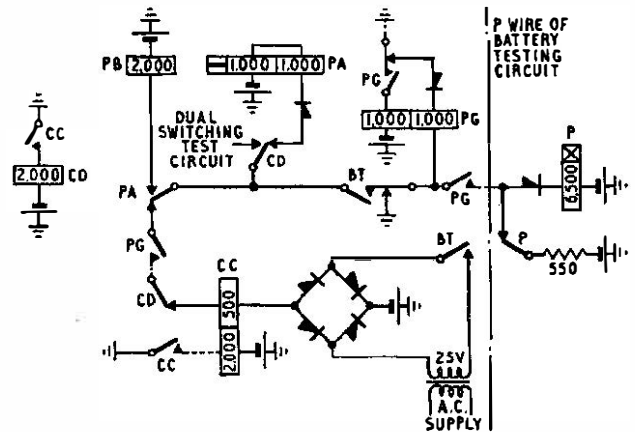

FIG. 3.—TESTING OF BATTERY-CONNECTED P-WIRE CIRCUITS.

elements of the routiner testing circuit. Under busy condition relay P is operated from an earth on the P-wire of the chain of switches forming the connection. The relay has a release lag and will remain operated with a current of less than 1 mA. It is not possible therefore to connect to it any testing device which will allow current exceeding 100  $\mu$ A, but it was preferred to avoid using a circuit employing a thermionic valve. As a mains transformer has been provided for use with the magnetic amplifier, an additional secondary winding and a bridge rectifier is used to provide 25V which will operate relay CC in series with the 550-ohms resistor and the 50-V common. The direction of current in this circuit is in opposition to the current normally operating relay P and reduces its release lag, while the rectifier element associated with relay P prevents its re-operation after release. An outline of the circuit follows:

In the routiner relay BT (not shown) is operated. Relays PA and PG operate in series and PG locks to its own contact. The P-wire is now extended via the routiner access switch and if the junction is busy relay PA remains operated to the earth on the P-wire. Relay PB operates via contact PA, giving a busy signal to the routiner.

When the holding earth in the main circuit is removed relays PA and PB release and relay CC is connected to the P-wire. Following release of relay P, connection of the 550-ohm resistor completes an operate circuit for relay CC in series with the 25V supplied by the rectifier network and transformer. Relay CC locks to its own contact and operates relay CD, which extends the P-wire for testing to continue.

### Conclusion.

The junction-testing routiner, of which only two unusual features have been described, will be installed in many automatic exchanges. It will provide additional testing facilities which will permit location of faults which were not previously detectable. Although the magnetic amplifier is not a recent development its application for telecommunication circuits has not been advanced. The circuit described may lead to a wider application in telephone exchanges.

## Part 2.—The P.A.B.X. No. 2

U.D.C. 621.395.24

The author gives an outline of the P.A.B.X. No. 2, which is similar to the P.A.B.X. No. 1 (see Part 1) but works in conjunction with a cord-type manual board and permits the connection of an additional 30 manual extensions. Some detail is given of the differences in circuitry, which relate particularly to calls handled at the manual board. Part 3 will conclude the series with a description of the largest exchange, i.e. the P.A.B.X. No. 3.

### INTRODUCTION

THE description of the automatic equipment of the P.A.B.X. No. 1 given in Part 1 applies, in general, also to the P.A.B.X. No. 2. The important difference is that for the No. 2 a conventional floor-pattern cord-type manual board is provided; and incidental to that, a group of 30 manual extensions, additional to the maximum of 49 automatic extensions, can be added for all sizes of automatic equipment. The greater proportion of the automatic equipment is common to both types of P.A.B.X. and the slight changes in circuitry are concerned with the different type of termination on the manual board and the changes in operating procedure.

The design of the P.A.B.X. No. 1 emphasises a main design objective which is to reduce operating attention to a minimum, vesting as much control as possible in the extension user. This must always be an important consideration when comparing the advantages of automatic working against manual working. Indeed, it is the most important factor from the subscriber's point of view, since he is usually concerned only with the hard facts of economic comparison and is unlikely to be impressed by the niceties of automatic working or the designing engineer's ingenuity. It may seem odd, therefore, that the P.A.B.X. No. 2 should have been introduced as it would appear to be a step in the wrong direction. At the time of the introduction of the P.A.B.X.s, however, it was considered that a demand would still exist in the special case, for the personal attention of a full-time operator. Although the demand for P.A.B.X.s No. 2 is at present very small, it is perhaps too early to suggest that its provision as an alternative was not justified.

### THE MANUAL BOARD AND MANUAL EXTENSIONS

The cord-type manual board is illustrated in Fig. 1. It is in fact the floor-pattern manual board now standard for all multiple P.B.X. installations whether manual or automatic. The equipment was described in its original form in an earlier article<sup>1</sup> and although it has undergone improvement since then, it is not sensibly different to-day. The dual function of the switchboard is achieved by jacking-in the appropriate cord circuit relay sets at the rear of the switchboard. The face equipment is, of course, arranged as required. A 50V cord circuit is used for auto working and an additional relay, differentially connected in series with the feeding relay, is used for recall purposes. Otherwise the circuit is similar to that used for manual working.

The numbering scheme and provision of automatic extensions is the same as for the P.A.B.X. No. 1. As previously mentioned, however, it is possible to provide an additional 30 manual extension circuits. These circuits are terminated directly on the manual board, the line relays being mounted at the rear of the switchboard. Connection to these circuits can only be obtained from the switchboard and they are thus different from the two manual circuits provided on the No. 1 equipment, which fall within the

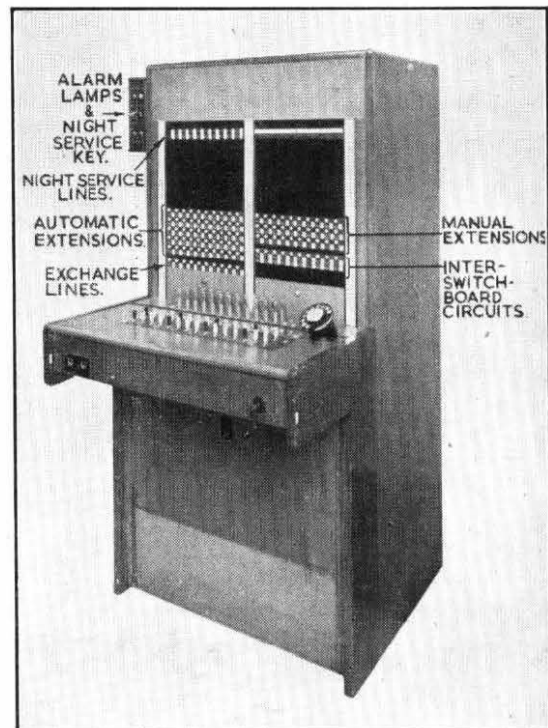

FIG. 1.—THE CORD-TYPE MANUAL BOARD.

automatic numbering scheme and are accessible from the auto multiple. It is of interest to note that they are allocated 3-digit numbers 010 to 029. The first digit "0" ensures that if they are dialled from an automatic extension the call will be routed to the P.B.X. operator.

### OUTLINE OF OPERATION

The similarity between the No. 1 and 2 types of equipment makes it unnecessary to go into detail except to point out some differences, particularly in the method of switching via the manual board.

The trunking arrangements are given in Fig. 2. Points of difference between this and the No. 1 trunking are that the cordless switchboard is replaced by the cord board; the marker and switchboard circuit is no longer required; the "0" level circuit is referred to as the "lamp lighting" circuit; and the extension multiple is connected to the manual board.

Extension-to-extension and direct-access incoming or outgoing calls operate in exactly the same manner as for the No. 1, but there are some changes in the manual board call.

### *Incoming and Outgoing Calls via Manual Board.*

The P.A.B.X. No. 1 cordless switchboard has no direct connection to automatic extension circuits and all calls handled by the operator are routed through the automatic equipment by means of key-sending and marking equipment. A jack and lamp appearance for every extension is

† Executive Engineer, Subscribers' Apparatus and Miscellaneous Services Branch, E.-in-C.'s Office.

<sup>1</sup> P.O.E.E.J., Vol. 32, Part 2, p. 57.

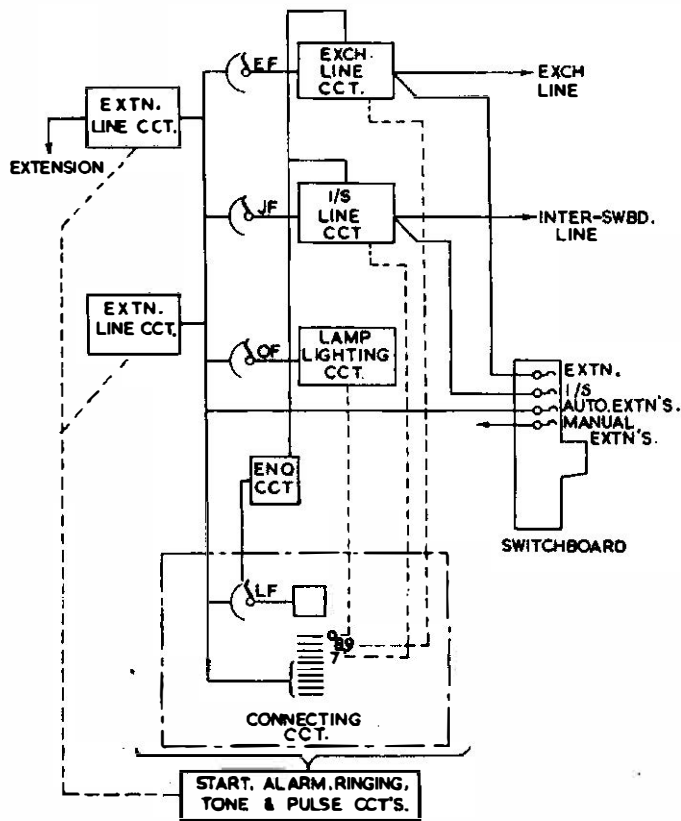

FIG. 2.—TRUNKING ARRANGEMENTS OF P.A.B.X. NO. 2.

provided, however, on the P.A.B.X. No. 2 switchboard and connection of calls by the operator follows normal P.M.B.X. practice. The method of obtaining the operator from an automatic extension is of interest, particularly because it applies equally to the smaller sizes of P.A.B.X. No. 3 (which will be described in Part 3 of this series) and is referred to as "lamp per line" working.

As with the P.A.B.X. No. 1 the extension dials "0" to obtain the operator. A similar sequence of operations takes place, i.e. the receipt of "0" by the connecting circuit causes an "0" level finder (OF) to find the calling extension. Separate "0" level circuits are not provided, however, and the circuit associated with OF is known as the "lamp lighting circuit." Its function is to light the calling lamp of the extension dialling "0" on the switchboard and return ringing tone.

Fig. 3 shows the elements of the circuit concerned. The

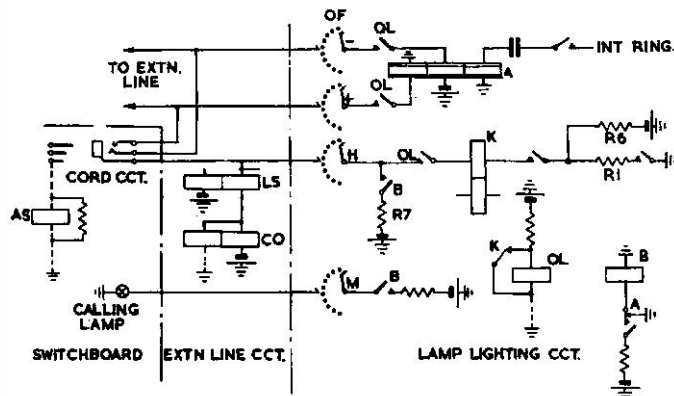

FIG. 3.—"0" LEVEL LAMP LIGHTING CIRCUIT.

receipt of a start signal causes OF to find the calling extension and the circuit is held over the hold wire (H). Relay A is operated from the extension loop and ringing tone is connected. The lamp on the switchboard is lighted over the M wire. The lamp lighting circuit is released when the operator answers, by releasing the holding relay K. The method of effecting the release of K is somewhat unusual because the only change of condition when the operator answers is the connection of the sleeve circuit to the H wire. The arrangement of resistors R1, R6 and R7 now becomes apparent—the 15-ohm coil of relay K is across a network comprising the sleeve circuit, line circuit and R7 on one side and R1 and R6 on the other, and the current through K is, for all practical purposes, reduced to zero.

#### SPECIAL FACILITIES

##### "Ring When Free."

This facility is not given on the P.A.B.X. No 2. It would be difficult to provide in any case, because there is no automatic equipment in circuit when an incoming exchange call is connected to an extension. Normal P.M.B.X. operating practice is therefore followed.

##### Enquiry and Transfer.

The enquiry facility is provided in exactly the same manner as for the P.A.B.X. No. 1, but automatic transfer is not provided while the switchboard is attended. The additional complication would be, of course, that, as an incoming call is set up through the manual board cord circuit it can only be transferred by the operator. It would be possible at the enquiry stage to connect the call through the automatic equipment, disconnecting it from the cord circuit and giving the operator a clearing signal, and so allow automatic transfer to be given. This method, has in fact, been used by some manufacturers for overseas equipment. It was decided for Post Office equipment, however, that manual transfer would be used and thus the extension user must call in the operator to transfer the connection.

During night service conditions, when the switchboard is not staffed, calls will be connected automatically to the extension by the use of "dial 8" night service and automatic transfer is given.

##### Night Service.

The standard "dial 8" night service arrangements apply. Additionally, as a standard facility it is also possible to provide "direct extension" night service, i.e. the connection of selected exchange lines to selected extensions by plugging them through at the manual board as in normal P.M.B.X. practice. Extensions so treated would not, however, have access to the P.A.B.X. equipment and could not participate in the "dial 8" service. They would become in effect single direct exchange lines.

##### Miscellaneous.

Alarms are extended to the manual board as in the case of the No. 1 equipment. Extension P.G. alarm is also provided but because each extension has a calling lamp on the switchboard the P.G. extension can be readily ascertained by operating a P.G. test key fitted on the switchboard, which will cause the calling lamp of the P.G. extension to glow. A manual extension will, of course, immediately light the calling lamp under P.G. conditions.

(To be continued)

# High-Voltage Power-Conductor Dropping Tests

U.D.C. 621.315.616.9: 621.316.93: 621.315.173

This note describes tests recently conducted by the Southern Electricity Board and the Post Office to determine the effect of dropping a 33 kV power line on Post Office wires and cables having coverings of P.V.C. and polythene, respectively. An outline of the results is given, and some conclusions drawn on the extent to which this new method of guarding Post Office lines at H.V. power crossings may be used.

## INTRODUCTION

THE protection of Post Office wires against contact with overhead power conductors is a problem which has been in existence since the earliest days of power distribution. With the development of the electricity supply system a large number of crossings of Post Office and power lines have taken place and in recent years, with the electrification of the rural areas, there has been a steady increase in the number. At crossings with H.V. power lines it has been standard practice for the Post Office lines to be protected either by the erection of a cradle guard between the two sets of plant or by undergrounding of the Post Office or H.V. line at the point of crossing. Such methods are expensive and the annual cost to both Electricity Supply Authorities and the Post Office has been appreciable. Consideration has therefore been given to new methods of construction which reduce the cost without lowering the standard of protection, for use where the voltage of the power line does not exceed 33 kV phase-to-phase (19 kV to earth).

These methods, which take advantage of the high dielectric strength of the plastic compounds known as polyvinyl chloride (P.V.C.) and polythene, make use of P.V.C. covered wires and polythene sheathed cables.

## NEW METHODS OF GUARDING

The P.V.C. covered wire consists of a 70 lb. cadmium-copper conductor sheathed with hard grade P.V.C. having a radial thickness of 60 mils. Laboratory and works tests have shown that this covering will withstand the maximum line voltage to earth, 19 kV, with an adequate factor of safety. Abrasion tests indicated that the resistance of the P.V.C. covering to the abrading action of a broken power conductor would be excellent—far superior in fact, to the P.B.J. covering which has been used for many years on conductors at low-voltage and medium-voltage power crossings. Incidentally, for this reason and because of the known good weathering properties of P.V.C., power conductors and Post Office wires sheathed with this material are being introduced as an alternative to P.B.J. covered types at low-voltage and medium-voltage power crossings.

When developing the new methods of guarding for H.V. crossings it was considered desirable to specify that a steel guard wire be fitted above the P.V.C. covered wires to take the initial impact of a broken power conductor. In addition the number of P.V.C. covered wires at a crossing was limited to four, the wires being supported by reel insulators. Two such insulators were arranged vertically one above the other on either side of the pole. This arrangement ensured that the P.V.C. wires would be almost directly below the guard wire and the maximum protection would therefore be obtained from the latter.

The polythene cable is that which has been developed for underground distribution purposes. In this cable polythene insulant is extruded on the wires, and the sheath consists of polythene containing carbon black.

Where polythene cable was to be used, it was to be lashed to a suspension strand, an arrangement considered desirable not only to support the cable but to ensure that the impact of a broken power conductor would be taken by the strand, which would thus tend to prevent abrasion of the polythene cable sheath.

Insulators were to be fitted in the suspension strand and also in the guard wire at each end of the crossing span, with the object of preventing dangerous voltages being applied to any apparatus on the poles. In the case of a suspension strand supporting a polythene cable the insulators would also tend to prevent a heavy flow of current through the contact resistance between a broken power conductor and the suspension strand. Such a current, if allowed to flow, might develop sufficient heat to melt the protective polythene sheath of the cable. It was also specified that the suspension strand make-off should not be erected in contact with earthed metalwork, such as stay wires, on the poles, in order that the insulators should be supplemented by a short length of pole. As the poles are generally stayed it is not usually possible, however, to allow much length of pole between the suspension strand and stay wire make-offs.

## DROPPING TEST OBJECTIVES

Power conductor dropping tests were carried out on the 23rd, 24th and 25th September, 1953. These sought primarily to confirm that the new methods of guarding were satisfactory. In addition it was desired:—

- (a) To determine the effect of dropping power conductors on P.V.C. wires which were not provided with a guard wire, and to see whether the P.V.C. covering would withstand the abrading action of power conductors of large and small cross-sectional areas.
- (b) To check that the insulators in suspension strands carrying polythene cable or those in guard wires were really necessary, by determining whether approximately 12 in. of pole between the suspension strand make-off and any earthed metalwork provided sufficient insulation.

## ARRANGEMENTS FOR THE TESTS

The tests were performed in conjunction with the Southern Electricity Board at Crowthorne in Berkshire. With the co-operation of the Forestry Commission a site was selected immediately adjacent to the Southern Electricity Board's 33 kV line linking their Crowthorne substation with Bracknell. Six poles were erected on the site, two forming the supports for a single power conductor with four others, two at mid span of the power line and two at quarter span, for the Post Office lines under test. Fig. 1 is a plan showing the general arrangement of the plant on site and Fig. 2 is a photograph of the test area. Pole A1 is shown in the right foreground of this photograph with H-pole No. 33 on the left.

The power conductor to be dropped was strung between poles A1 and A2 which provided a span of approximately 100 yds. The conductor was carried at pole A1 by a standard suspension insulator string but at pole A2 it was supported from special conductor releasing gear. This gear, which was designed and manufactured by the Southern Electricity Board, consisted of draw tongs mounted on insulators. The tongs were controlled by an insulated handle located at the foot of the pole and operation of this handle allowed the conductor to be released and fall freely on the Post Office line plant. Fig. 3 shows the general arrangement of the releasing gear at the head of pole A2.

Pole A1 was approximately 30 ft. from H-pole No. 33 of



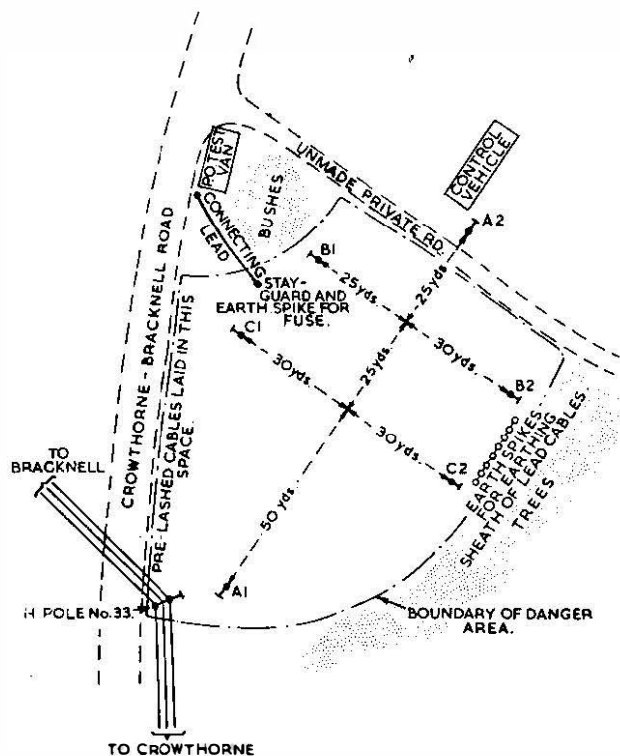

FIG. 1.—GENERAL ARRANGEMENT OF PLANT ON TEST SITE.

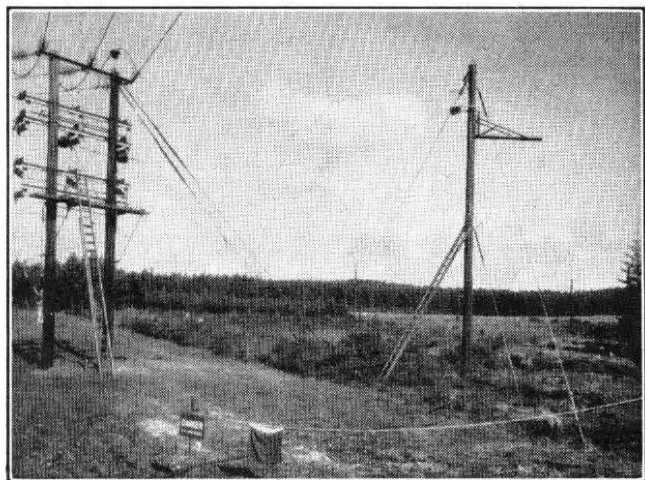

FIG. 2.—THE TEST AREA AT CROWTHORNE, BERKSHIRE.

the Crowthorne to Bracknell 33 kV line. The latter pole carried isolating and earthing switches to which the conductor to be dropped was connected by means of a jumper. The jumper enabled the dropping conductor to be connected to any one of the three-phase conductors of the 33 kV line.

For the days of the test the power line was taken out of service but when energised prior to each drop it was connected through a circuit-breaker in Crowthorne sub-station to a working 33 kV system which was earthed at, and fed from, Earley power station near Reading. In order to avoid interruptions in the local 33 kV network the operating time of the circuit-breaker at Crowthorne was arranged to be appreciably shorter than that of the circuit-breaker at Earley.

The estimated value of the fault current for an earth fault of zero resistance on one phase at the test site was 800 A. The values recorded during the tests were, however, generally restricted to appreciably smaller values by the resistance to earth of the conductor when it made contact

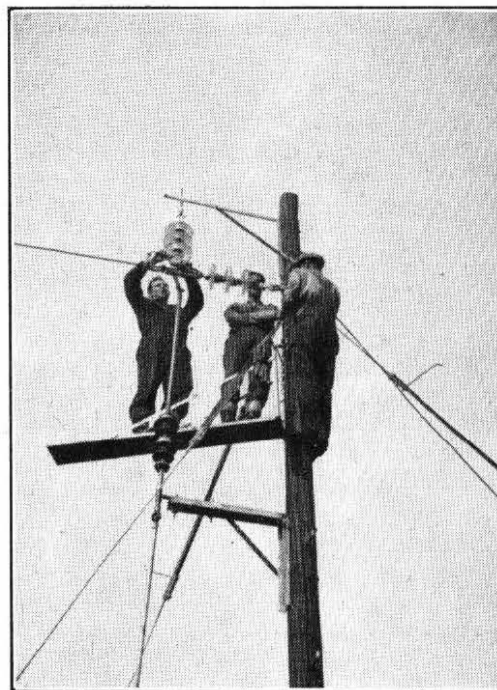

FIG. 3.—HEAD OF POLE A2, FITTED WITH CONDUCTOR RELEASING GEAR.

with the ground.

The tests were performed with two sizes of power conductor, the first of 0.2 sq. in. cross sectional area (7/193 in., tension 2,600 lb.) and the second with a conductor of 0.025 sq. in. cross sectional area (3/104 in., tension 240 lb.).

It was stipulated that new, unstressed, conductors should not be used as it had been found from previous tests that if such conductors were used there was a tendency for them to wrap round the Post Office wires when released. Conductors which have been stressed in use do not exhibit this tendency. It was also expected that the abrading action of a weathered conductor would be greater than that of a new, unexposed, conductor.

Post Office plant was tested at:—

- (a) A crossing approximately one quarter of the dropping span from the H.V. pole carrying the release gear (poles B1, B2 in Fig. 1).
- (b) A crossing at the mid point of the dropping span (poles C1, C2 in Fig. 1).

Both crossings had a span of approximately 60 yds. All poles had a single back stay and Fig. 4 shows the general arrangement of such a pole, actually C1 with B1 in the background. The stay wires were fitted with L.V. power line stay insulators, which are normally expected to withstand up to about 20 kV, and provision was made for these to be strapped over as desired. It will be seen from Fig. 4 that the insulator concerned has in fact been short-circuited.

To facilitate rapid changing of the Post Office plant between tests all cables were pre-lashed to suspension strands terminated on shackles, the poles being fitted with eye-bolts to which the shackles could be readily attached. P.V.C. wire had also been previously cut into span lengths and terminated on reel insulators with loops large enough to enable the wire to be quickly placed over, or removed from, the insulators. Prior to the tests both cables and wires were laid out adjacent to the site, and the storage area is shown in Fig. 5.

In all tests the vertical separating distance between the power conductor and the Post Office wire or cable was between 8 ft. and 10 ft.

Before each test the insulators in the suspension strand

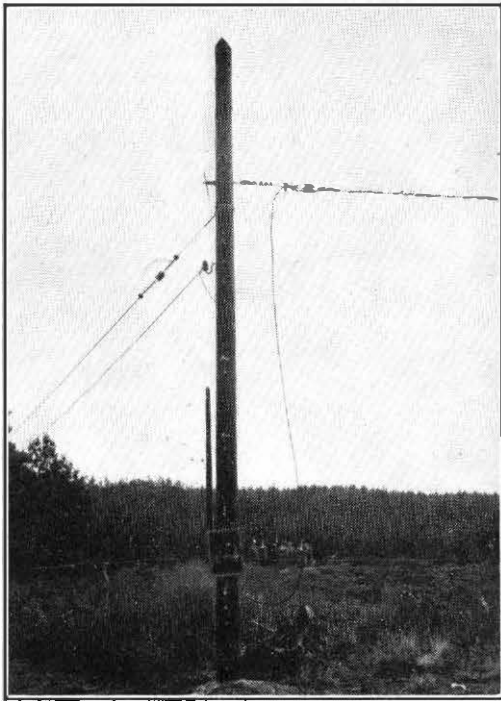

FIG. 4.—ARRANGEMENT OF POLE CARRYING TELEPHONE WIRE OR CABLE.

and stay wires, together with the poles, were liberally sprayed with water.

#### RECORDS

To provide a ready indication of the failure of insulation on the wire or cable under test the conductors, bunched together, were connected to an earth electrode through a fuse. The resistance of this earth electrode was of the order of 125 ohms and the fuse was rated to blow at 1 A. The conductors of the Post Office wires or cables under test were also connected, by means of well insulated leads, to measuring equipment with which oscillographic records of voltages appearing on the conductors could be made. This equipment was situated in the test van seen in the background of Fig. 5. As the measuring equipment had a high impedance—about 2 megohms—the low impedance earthed connection via the fuse was necessary to eliminate the possibility of false readings due to capacitive effects.

The earthing of the wires and cable pairs through the fuse ensured that if the insulation of the wires or cables broke down, the damage would be readily visible. The



FIG. 5.—P.O. CABLES AND WIRES PREPARED FOR RAPID CHANGING BETWEEN TESTS.

current which would have passed to earth through the measuring apparatus would have been of the order of a few milliamps only, but earthing of the conductors ensured that a heavier current flowed which thus produced readily discernible damage.

The phase-to-neutral voltages and the fault currents on the 33 kV system were recorded by equipment in Crowthorne substation. This equipment was provided and operated by the British Electricity Research Laboratory Staff.

Cinematograph records of each drop were made, two records being obtained, one at normal speed and the other at 1/30th of normal speed. The latter forms a useful record in slow motion of the events which occurred when a line conductor struck Post Office wires and also, as sometimes happened, when the insulators at the point of connection of the Post Office wires to their supports, flashed over.

#### CONTROL OF SITE

It will be appreciated that the dropping of a live 33 kV conductor is, to say the least, a highly dangerous operation. Rigorous control of the exercise was, therefore, essential and the immediate area of the test site was roped off and declared dangerous.

Actual control of the site was achieved by the appointment of a Site Controller who issued "Permits to Work" to nominated personnel of the Southern Electricity Board and the Post Office in charge of the various aspects of work on site. He also regulated operations through a public address system covering the operating site, together with special control circuits from the site to Crowthorne substation and telephone exchange. The Site Controller was stationed in a mobile office from the door of which he could survey the whole of the roped-off area. A flag pole was erected immediately adjacent to this office, a red flag being exhibited when it was dangerous to enter the test area and a green flag when it was safe to do so. The Site Controller was a member of the Southern Electricity Board.

It is of interest to note that if the conductor struck the ground whilst still alive the arcing to earth, although of short duration, was sometimes sufficient to ignite the bracken which covered the site. Arrangements were in fact made for fire fighting appliances to be available at the site to prevent such a fire gaining a hold.

#### RESULTS

##### *P.V.C. covered Wire.*

Tests were carried out on P.V.C. wires without a guard wire and the results were very satisfactory. In no case did the falling power conductor cause other than very slight superficial damage to the insulating covering even when the 0.2 sq. in. conductor was used. These results have shown the guard wire to be unnecessary and this will not be used. It has also been decided that there is no reason to limit to four the number of P.V.C. wires at crossings with lines of voltages up to and including 33 kV, and it appears that this wire could be used at such high voltage power crossings in exactly the same manner as P.B.J. wire has previously been used at low voltage crossings.

Due to the very satisfactory results of these tests the Post Office and the Electricity Boards are now giving consideration to the use of P.V.C. covered power conductors at crossings of power lines and Post Office lines. This arrangement, if approved, will effect further savings as it will sometimes be less costly to a Board, when second comer, to provide this protection on its lines and thus avoid the necessity for modifying the Post Office lines.

##### *Polythene Cable.*

Tests carried out on polythene cable did not prove so

satisfactory, the insulation of the cable breaking down in some cases. The lengths which failed were taken from one particular drum whilst those which did not fail were drawn from another.

In all cases where failure occurred, the cable sheath was not punctured or damaged at the point of impact between the power wire and Post Office cable. In every case failure appeared just as likely to occur at any one point as at any other. Examination of damaged lengths showed that the aluminium foil screening incorporated in the cable did not present a smooth cylindrical surface. The foil wrapping often formed ridges and high points and when the polythene sheath was extruded over these they became embedded in it and materially reduced the thickness of the sheathing at many points. The polythene cable was lashed to the steel suspension strand with steel lashing wire and when a power conductor fell on a suspension strand the high potential stressed the polythene cable sheath at all points along its length; thus if at any point the thickness of the polythene sheath had been reduced by the presence of ridges or points on the aluminium screening it broke down.

In view of the results obtained it is considered inadvisable, pending development of a more suitable cable, to use polythene-sheathed cable for crossings of power lines exceeding 11 kV phase-to-phase.

In some tests with polythene cable where L.V. power line type stay insulators were used in the suspension strand, flash-over of the insulators took place even when 12 in. of pole had been allowed between the suspension strand

termination and stay wire make-off. In one test when insulators were also fitted in the stay wires, flash-over took place across the suspension strand insulator, 12 in. of pole and the stay wire insulator, all in series.

The results of the foregoing tests have proved so valuable that permission has been sought and obtained from the Forestry Commission to carry out further trials in the near future. At these, it is hoped, among other things, to test the new plastic-sheathed cables which it is anticipated will become available to replace those which failed on test.

#### ACKNOWLEDGMENTS

It will be appreciated that the trials described in this article involved the close co-operation of many different organizations and acknowledgments are due to the following for their part in the successful completion of the exercise:—

The British Electricity Authority; The Southern Electricity Board; The Forestry Commission; The British Electrical and Allied Industries Research Association; The Post Office Research Station; The External Telecommunications Executive; Home Counties Region; Reading Telephone Manager's Office; and finally the authors' colleagues in the Construction Branch, E.-in-C.'s Office.

Special acknowledgments are due to members of the gangs employed by the Post Office and Southern Electricity Board on site, all of whom gave enthusiastic support and assistance at every phase of the operation.

S.J.L., H.F.

---

## British Contact Research: Loughborough Convention, 1952

U.D.C. 061.3:621.3.066.6

**Sixteen papers dealing with Electrical Contacts were presented at the Loughborough Convention of 1952 arranged by the Institution of Electrical Engineers. This note gives a survey of some of the results of original research which were presented at the Convention, and emphasises the importance of surface films.**

**E**LECTRICAL contacts are the most widely used of all circuit components: those maintained by mechanical force, as distinct from those maintained by solder or a weld, are the most important items in current types of communication system. In a general way, these facts have long been known: unfortunately, however, their significance has not been either sufficiently fully or sufficiently widely realised. Contacts are rarely given the status of components and are often regarded as incidental to, rather than as a starting point for, circuit design. It is commonly supposed, not always with adequate justification, that, in comparison with what is known about other components, little is known about contacts. Consequently, little effort is made by users to understand their behaviour, and when some ostensibly mysterious phenomenon is encountered, the contact is sometimes rather unfairly described as "crazy."

The Convention on Electrical Contacts held by the East Midland Centre of the Institution of Electrical Engineers at Loughborough College in April, 1952, should go some way towards remedying this unhappy situation. It provided a means of presenting and discussing, in little more than two days, sixteen papers containing material of either an original or a review nature. But, more significantly perhaps, it enabled nearly two hundred users, designers or investigators to meet and discuss outstanding problems from widely different points of view. The Convention was opened by Dr. W. G. Radley, Vice-President of the Institution, and the proceedings were divided into two parts. Part I comprised ten papers and a discussion on Light Duty Contacts: Part II, six papers and a discussion on Heavy Duty Contacts. No advance copies of papers were available.

A brief, non-technical description of the Convention was published in May, 1952, in the Journal of the Institution, and a more detailed account, including some of the papers, in July, 1953, in Part I of the Proceedings of the Institution. The present discussion is restricted to a survey of some of the results of original research. Viewed in retrospect, the proceedings left three main impressions. First, a welcome sense of an increasing awareness of the great importance of surface films in most applications. Secondly, some justification for the view that many engineering difficulties arise from a widespread lack of appreciation of basic principles and from a lack of design data, and not from a complete absence of knowledge or from limitations inherent in existing materials. And thirdly, the not unexpected conclusion that most new knowledge of contact phenomena is coming from research initiated in the field of light-current, and not heavy-current, engineering.

Surface contaminants may consist of accidental deposits such as dust or grease, or of films produced by adsorption, tarnishing or corrosion. The overall effect of such contamination may not necessarily be adverse; it can be beneficial. Foreign layers of the thicknesses usually encountered with exposed equipment lead inevitably to high resistance connections at voltages which are too low to initiate conduction by a process of "breakdown." The resistance at a sufficiently higher voltage may, however, be tolerable, although it will not be that corresponding to simple metallic contact. Electrical wear or erosion is also greatly affected by contamination. Field emission at small separations during closure can be increased greatly by dust and tarnish: this enhanced emission can readily initiate discharges which lead to erosion. Discharges are not, however, always

initiated by field-emission, and neither are they the only cause of erosion. With nominally stationary contacts, there are few, and rarely any, compensations for such wholly adverse effects; but with sliding contacts, for which mechanical wear is of importance, this is not so. Surface films can control the extent to which metallic junctions are established between the sliding surfaces. The work-hardening or work-softening properties of the metals may then determine which surface wears the faster. Alternatively, this may be governed by the relative hardness of film and metal. Films produced by adsorption, as distinct from those produced by tarnishing, are of special significance. It has long been known or suspected that clean surfaces tend to adhere and that the forces responsible are "chemical" in nature and capable of saturation. Any substance such as an adsorbed film which tends to produce saturation behaves as a lubricant.

With opening contacts transmitting suitably large voltages and currents, several processes can precede disconnection. The final connection between the surfaces can take the form of a discharge: this can be preceded by a molten metallic bridge supported by surface tension. The rupture of the bridge, at a temperature nearly that of the boiling point of the metal, can provide initiatory electrons for the discharge. The unsymmetrical nature of the rupture, due to Thomson effect, can lead to build-up of one surface at the expense of the other, i.e., to material transfer.

Several papers dealt, either wholly or in part, with the effect of surface films on contact resistance and mechanical wear. In one of these an account was given of the behaviour of metallic contacts at low voltages in adverse environments. An attempt was made, for the first time, to describe the behaviour of a closed contact subjected to corrosion, and the closure processes for a corroded contact, both with and without "wipe." The principles outlined provide some theoretical basis for design and testing techniques. The starting point for the corrosion problem was the basic representation of a contact interface as a region in which contact obtains at a few spots only. The total area of the spots is ideally just that required to support the contact force. Corrosion can be either self-blocking or continuous; if blocking obtains then, in the absence of disturbance, metallic contact can be maintained indefinitely. Continuous corrosion might, however, be expected to result in loss of metal at the perimeter of each spot, and the replacement of this metal by plastic flow from the interior of the spot, so long as the corrosion product remained mechanically unimportant. The discussion of the closure problem was concerned primarily with the response of a "thick" and loosely-adherent film to a single surface asperity, or ideally, to a hard, smooth, spherical indenter, and with a possible mechanism of film-fracture when the applied force is either entirely normal to the contact surface, or is combined with a sideways traction or "wipe." If the film is hard, the base soft and the force normal, then gross deformation of the base can occur without the establishment of metallic contact. If the film is soft and the base hard, then wiping might be expected to reduce the force required to establish metallic contact roughly in the ratio of the compressive and tensile strengths of the film material. Wiping must not be done too quickly and a certain minimum normal force is needed for it to be effective. Films can also give rise to electrical noise in circuits containing contacts subjected to vibration. It usually arises in situations where the film is not penetrated mechanically, but connection is established by the use of a sufficiently high voltage: repeated disturbance results in successive breakdowns and noise. With sliding contacts, when the lowest possible contact resistance is not essential, certain kinds of film can

be used with considerable advantage. Polytetrafluoroethylene gives low friction, and a thin layer of severely limited thickness can be deposited on a metallic surface by rubbing. This gives a means of lubricating a sliding metallic contact system by a "dry transfer" process.

Another paper dealing with surface films was devoted to the wear of carbon brushes at high altitudes. The self-lubricating property of a carbon brush results from atmospheric water: at high altitudes, where the atmosphere is dry, friction is high and wear is catastrophic. In a chemically-clean experimental system, the effect of water vapour is practically instantaneous and is reversible: wear stops immediately when the water vapour pressure is raised above a critical value, and recommences almost as quickly when the pressure is reduced below this value. The surface of a copper commutator is usually covered by a film of carbon on cuprous oxide and rubbing takes place between carbon and carbon. Lubrication can be maintained in dry environments by means of adjuvants able to withstand the high temperatures and mechanical stresses at the contact regions. The most successful materials for this purpose have been the metallic halides such as barium fluoride. It has been supposed that both water and the adjuvants provide lubrication by saturating the surface forces of the carbon. An alternative view is that they act as catalysts by promoting oxidation of the copper by atmospheric oxygen. Neither theory seems completely satisfactory: water is effective when all gases are practically absent; cuprous oxide provides no lubrication, and barium fluoride is ineffective with silver. In a normal environment, the temperature rise of an adjuvant-treated brush is frequently much higher than that of an untreated brush on the same machine, due mainly to greater electrical loss and partly to increased friction. The ability of the brush to maintain an even distribution of current over its surface is also reduced.

Five papers dealt with electrical, as distinct from mechanical, contact wear, and one, in particular, with the effect of surface films on the initiation of discharges. Two conditions must be fulfilled for a discharge to occur in the gap between two contacts: a sufficient number of initiatory electrons must be produced at the right time in the gap; and some mechanism must exist which sufficiently amplifies the number of electrons and builds up an avalanche; this mechanism is determined by the electric field and the electron free paths in the gas. Three phases of low-power operation can be identified; break at medium voltage (50-300V); break at low voltage (4-10V); and make. Both the essential conditions for a discharge are satisfied for a medium-voltage break. The explosion of the molten bridge supplies not only a hot-spot, thermally-emitting electrons, but also a quantity of positive ions and neutral atoms of the evaporated metal. The high field and low gas density are favourable to ionisation by collision so the thermally-emitted electrons can be amplified to produce an avalanche and so set up a discharge. Both contacts are subjected to severe bombardment—the cathode by ions and the anode by electrons—and evaporation ensues: it is difficult to make a general statement regarding transfer. Both the essential conditions for a discharge can also be satisfied for a low-voltage break provided that the circuit inductance is sufficient (about 0.1 microhenry) to produce the necessary higher voltage. The essential conditions can also be satisfied for a make when the surface state results in the provision of the necessary initiatory electrons by field emission: the contact separation might otherwise be too small for natural ionisation to be effective. The electrons can be extracted in two ways: directly from "thick" ( $10^{-5}$  cm.) films, e.g., of oxide and, in particular, from oxygen ions; or from the parent metal through a "thin"



( $10^{-7}$  cm.) film, as a consequence of the high field provided by positive ions, produced perhaps by sparking, residing upon its surface.

Closely related to this paper was another dealing with the effect of inductance on "fine" transfer between platinum contacts. "Fine" transfer, or migration, is that which is observed on breaking circuits in which "coarse" arcing is supposed to have been eliminated, and is comparatively small in magnitude. "Normal" transfer is associated with a gain of material by the cathode, and results in a pip on the cathode and a corresponding crater on the anode: "reverse" transfer defines the opposite effect. Bridges can contribute to such transfer but are not the only possible cause of it. Experiments had been done with platinum contacts in a 6V circuit breaking currents of the order of 1A: the circuit inductance was varied from 0.05-10.0 microhenries. The results demonstrated the existence of two types of normal transfer: one independent of inductance and consistent with the effect of bridging; the other dependent on inductance and consistent with the effect of a short arc. The latter becomes significant when the inductance exceeds about 3 microhenries: it may be a consequence of an arc so short in duration and length that much of the stored inductive energy is carried by electrons and dissipated on the anode, causing melting and evaporation of metal. Much of the evaporated metal is re-deposited in anode craters but some reaches the cathode, possibly as positive ions.

The third paper in this group dealt with long-life contacts for unidirectional currents of 1-20A, such as are encountered in vibratory converters. In such devices, output powers ranging from a few watts to a kilowatt need to be associated with a life of the order of  $10^9$  operations. Experiments had been performed with quenched and unquenched platinum contacts breaking currents of 1-5A in a 1-2V circuit: and currents of 10-20A in a 4-24V circuit. With currents of 1-5A and voltages less than 1, no transfer was observed; with voltages in the range 1-1.5, reverse transfer occurred; and with voltages greater than 2, the transfer was normal. These results were unaffected by the presence of a quench, but with voltages in the range 1.5-2, reverse transfer occurred only in the presence of the quench. The reverse transfer is not inconsistent with the effect of bridging. With currents of 10-20A in a 4-24V circuit, a quench was necessary to prevent coarse arcing; the magnitude and direction of transfer was then strongly dependent on the inductance of the quench. As this was varied from 0.1-100 microhenries, the direction of transfer changed three times; it was reverse for inductances of the order of 100 microhenries, when the quench became ineffective; and also for inductances in the range 0.5-2.0 microhenries, due, probably, to a short arc and the production of positive ions.

The fourth and fifth papers were devoted to molten metallic bridges: the fourth to the theory of their growth, and the fifth to their effect on fine transfer. The history

of separating contacts may be divided into two parts: the stage up to the beginning of melting (chiefly of interest in order to find out where melting begins) and the later stages up to breaking. The theory of the pre-melting stage is not difficult if separation is slow enough to ensure thermal equilibrium; in practical contacts, however, thermal equilibrium is a poor approximation before melting, but becomes a good one afterwards. Information regarding the first stage can be obtained by the use of certain similarity theorems: for the second stage, it is necessary to calculate the shape of the liquid surface. Neglecting electrodynamic forces and the variation of surface tension with temperature, this can be done with the aid of the following theorem. For a liquid at rest, with uniform pressure and surface tension, the possible shapes are those traced out by a focus of a conic section which is rolled along the axis of symmetry; and according as the conic section is a hyperbola or an ellipse, the curves are of two types. These are the nodoid, when the pressure in the liquid is less than the external pressure, and the unduloid for the converse situation: the intermediate case, for equal pressures, is the catenary obtained by rolling a parabola. Changes in the shape and size of the bridge with contact separation depend greatly on the properties of the metal and on the external circuit. Bridges may be divided into two classes: those which have a pure surface and are, as a consequence, never free from internal motion; and those which have a contaminated surface and are at rest. Even in bridges of the latter type the surface shape is always modified by electrodynamic forces. A bridge in which the bridge power is an increasing function of the bridge length breaks either at the boiling voltage, or at one half the circuit voltage if this is less than twice the boiling voltage.

There is still no generally accepted view of bridge transfer, but there is evidence that it is the result of temperature asymmetry and the Thomson effect can produce such asymmetry. For iron, there is evidence, based on the assumption that breakage occurs at boiling, that the Wiedemann-Franz law is approximately valid; that boiling is the cause of breakage; and that asymmetrical breakage is produced by asymmetrical temperature distribution which may have been caused by Thomson effect. The situation is, however, complicated by oxidation. On the other hand, observations with platinum support the view that breakage occurs before boiling if the circuit voltage is not greater than about twice the boiling voltage; if this condition is satisfied, boiling is still the deciding factor. Bridge formation in a bimetallic contact is more complex than in a monometallic one. Bridge behaviour in a copper-iron system is markedly dependent on electrode polarity; the influence of Thomson effect predominates over that due to differing electrical and thermal conductivities. Bridge behaviour in a gold-platinum system is, however, characteristic of platinum; differing electrical and thermal conductivities are the predominant influence.

A. F.

## Book Review

"Modern Armature Construction, Winding and Repair."  
Stuart F. Philpott, M.I.E.E. Sir Isaac Pitman & Sons, Ltd. 271 pp. 187 ill. 30s.

It is refreshing to find a book which adheres so closely to its title as this one and covers its subject so thoroughly. Only sufficient theory of electrical machine design is given to enable the armature winder to appreciate the reasons underlying his work, and then the author deals with all the practical aspects of his subject. The chapter headings are:—Armature Principles, Construction, Machine Winding, Former Wound Armatures, Connecting to the Commutator, Armature Faults

and Testing, Soldering, Securing the Windings, Varnishing, Undercutting, Turning and Finishing, Balancing and Repairs to Armatures. The author is obviously very well acquainted with this subject which he presents in a very readable manner. He describes many of the special machines used in the bulk production of armatures.

The book should be of considerable value to those engaged in the manufacture and repair of armatures for small machines and contains much interesting reading for the student of electrical engineering.

The line drawings are well executed, but some of the photographic illustrations appear to have suffered in reproduction.

A. E. P.

# Notes and Comments

## Recent Award

The Board of Editors has learnt with great pleasure of the honour recently conferred upon the following member of the Engineering Department:—

Shrewsbury Telephone Area .. Knott, W. A... Technician I, .. Squadron Q./M. Sergeant, British Empire Medal  
Shropshire Yeomanry, T.A.

## New Year Honours

The Board of Editors offers congratulations to the following members of the Engineering Department honoured by Her Majesty the Queen in the New Year Honours List:—

Aberdeen Telephone Area .. ..	Birnie, R. C. .. ..	Area Engineer .. ..	Member of the Order of the British Empire
Cupar Radio Station .. ..	McLaren, W. .. ..	Leading Technical Officer ..	British Empire Medal
Engineering Department .. ..	Little, G. J. S., G.M... ..	Assistant Engineer-in-Chief ..	Commander of the Order of the British Empire
Engineering Department .. ..	Radley, Dr. W. G., C.B.E. ..	Engineer-in-Chief .. ..	Knight Bachelor
Engineering Department .. ..	Stevens, F. W. .. ..	Technical Officer .. ..	British Empire Medal
Gloucester Telephone Area .. ..	Brookes, J. W., M.M. ..	Technical Officer .. ..	British Empire Medal
Middlesbrough Telephone Area ..	Dodds, J. W... ..	Leading Technical Officer ..	British Empire Medal
Peterborough Telephone Area ..	Allen, F. .. ..	Inspector .. ..	British Empire Medal

### Sir W. Gordon Radley, C.B.E., Ph.D.(Eng.), M.I.E.E.



The knighthood conferred upon the Engineer-in-Chief, Dr. W. G. Radley, in the New Year Honours List, has caused gratification to the whole of the Engineering staff of the Post Office.

The list of former holders of the highest post in the Engineering Department is both long and impressive; few will disagree, however, with the view that in Sir Gordon Radley we have an Engineer-in-Chief of exceptional capacity and versatility to lead the Department. The honour of knighthood is a fitting tribute to his achievements in the telecommunications field and, indirectly, to the work of the engineering staff under his leadership.

We are sure that Sir Gordon's many friends and associates in the telecommunications sphere at home and abroad will wish to join with us in an expression of warmest congratulations on his latest distinction.

### R. J. Halsey, B.Sc., A.C.G.I., D.I.C., M.I.E.E.

Mr. R. J. Halsey took up his new duties as Assistant Engineer-in-Chief in December, 1953, filling a new post created to cover Submarine Cable Systems—the Transatlantic project in particular. This well-deserved appointment underlines the developments which have taken place in the line transmission field since his entry into the Post Office, with most of which he has been connected in one way or another.

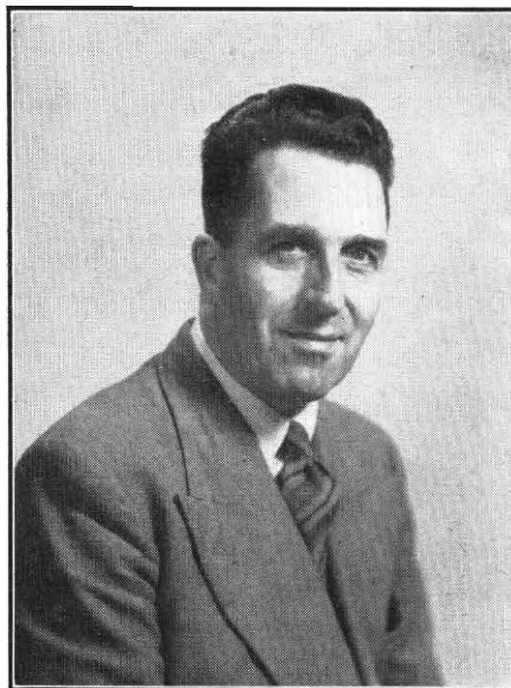

Mr. Halsey served his time as a shipwright apprentice in Portsmouth Dockyard, and winning a Royal Scholarship proceeded to the City and Guilds College in 1923. Having concluded a post-graduate course (in traction) he spent a year at the City and Guilds as a demonstrator and entered the Engineering Department as an Assistant Engineer in 1927 by the Open Competition. He joined the Research Branch, Transmission Section, which at that

time was at Marshalsea Road, and was promoted to Executive Engineer in 1936 and Assistant Staff Engineer in 1941. In 1947 he was promoted to Staff Engineer of the Line Transmission Division of Research Branch. He was concerned with line transmission in general until June, 1953, when a new Division was formed to deal with Submarine Cable Systems, of which Mr. Halsey took charge.

It is interesting to note progress in line communication as shown by his contributions to this Journal, and we see that the first article in 1933 described "a simplified carrier system for open wire lines"; its opening sentence reads, "The art of carrier telephony is now a well developed one and it is practicable to provide carrier telephone circuits of sufficiently good quality for any speech transmission systems." Nowadays carrier circuits are at least as good as audio circuits and in some respects vastly superior. Further articles (in some cases with other authors) dealt with music circuits, the Carrier System No. 4, a modified version of which was adopted by the Army, the application of carrier and submerged repeaters to submarine cables, and the transmission of television over coaxial pairs. His papers to the I.P.O.E.E. and I.E.E. include the subjects of speech compression, filter design, magnetic materials, and submerged repeaters.

He was a member of the 3rd C.E. of the C.C.I.F. for many years, and has served on numerous other Committees, including the recent working party reviewing the work of S.E.E.s and E.E.s.

In his personal characteristics Mr. Halsey is notable for an apparently inexhaustible fund of energy and for the enthusiasm with which he approaches any job that needs to be done. As these characteristics are supported by high technical ability and a capacity for the rapid assimilation of new ideas, it is not surprising that he has made his mark in his chosen field. His career shows that this has not been a narrow one, but has embraced all aspects of line telecommunication. In some ways he may regret that for the immediate future he will have to leave to others the progress of line transmission on land, but the magnitude of the transatlantic telephone cable project should afford him some compensation. This project is perhaps unique in combining with the technical problems of low-power electrical engineering a huge programme of cable production and laying, and in representing a co-operative effort by three countries. We can rely on Mr. Halsey to represent, in the forthright manner we know so well, the British point of view in this joint project.

H. W.

#### **J. J. Edwards, B.Sc.(Eng.), D.I.C., M.I.E.E.**

Mr. J. J. Edwards entered the Post Office Engineering Department through the Open Competitive Examination for Probationary Assistant Engineer in 1926 after having taken his degree course at the City and Guilds Engineering College during the preceding three years, and obtaining the College Diploma, the Diploma of the Imperial College, and the degree of B.Sc.Eng.(Hons.). After spending his probationary training period in the old Metropolitan Power District, he was appointed Assistant Engineer in the Technical Section of the Superintending Engineer's Office of the North Eastern District at Leeds, where for four years he was the Power Engineer for that District.

In 1931 he was transferred to the Construction Section of the Engineer-in-Chief's Office where he remained until 1950, becoming Executive Engineer in 1935 and Assistant Staff Engineer in 1939. Here, he was concerned with the design of tools, mechanical aids, and special-purpose plant for Post Office requirements; he served on the Government Department Committee on the co-ordination of hand tools. In 1935, he became responsible for external construction

practice and the introduction of new methods as well as for special cases involving non-standard designs, one of the most notable being the cables laid across the Forth Bridge in compound-filled troughing. Among many other items, he was closely concerned with the introduction of special-purpose cable-drum trailers.

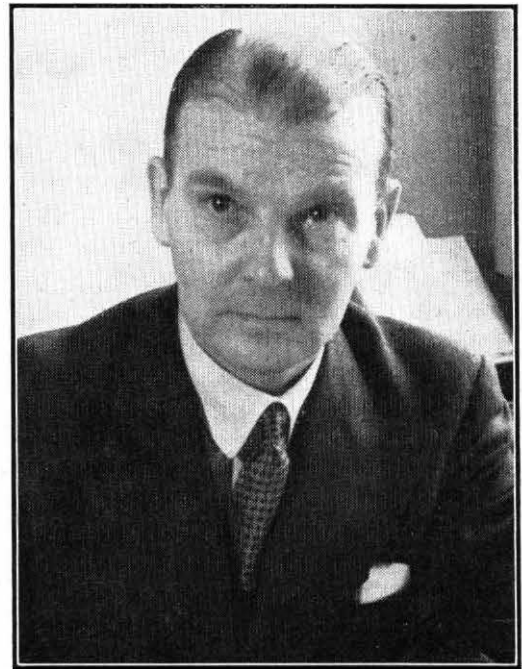

During the war years he took responsibility for the engineering aspects of damage cases and the development of new cable-laying methods for use on aerodromes. In the post-war period he was responsible for the protection of Post Office plant from power interference and corrosion and was among the United Kingdom representatives on the first and second Commissions of the C.C.I.F. dealing with these subjects.

Early in 1950 he was transferred to the London Telecommunications Region where he became responsible for the Lines Planning Division of the Engineering Branch. Here, his previous experience on external matters proved invaluable and in 1951, he was appointed Deputy Chief Regional Engineer in charge of planning and major works. Here, he was concerned with the design and construction of major civil engineering works of special character as well as with the financial aspects of engineering, estimates and budgetary control.

In addition to his vast experience and technical knowledge, Edwards possesses a lively personality and a sense of humour which serve to carry him through those periods of high pressure activity that are the fate of any senior engineering member of a Regional Headquarters staff. The L.T.R. is sorry to lose him and he goes to his new post with the good wishes of all his friends and colleagues in the Region.

W. S. P.

#### **R. A. Brockbank, Ph.D., B.Sc., A.M.I.E.E.**

In January, 1954, Dr. R. A. Brockbank took over the Submarine Systems Division of the Research Branch in succession to Mr. R. J. Halsey.

Submarine systems nowadays are very much tied up with submerged repeaters and the development work leads into many branches of engineering, physics and chemistry, quite outside the scope of line transmission as generally known. Dr. Brockbank is fortunate, therefore, in having

had a varied background such as few can call upon.

Graduating from East London College (now Queen Mary's College) at the age of 19, in 1921, he spent about a year with Siemens Brothers in the Signalling Laboratory and then went as a student to the Western Electric Company (now Standard Telephones and Cables). At the end of the course he spent a period on the design of telephone and power cables and, in particular, on work on dielectric and sheath losses, much of which was original research. At this time he was very interested in the London Students Section of the I.E.E., of which he was Chairman in 1927-1928.

Dr. Brockbank was then transferred to the I.T. and T. Laboratories at Hendon, where he continued his work on

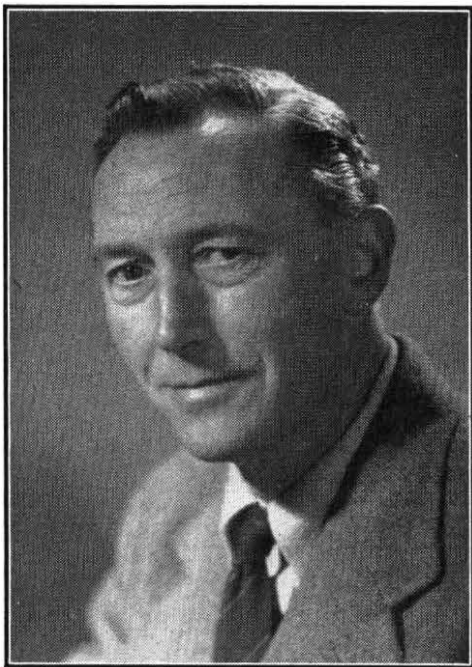

power cables for a time and was later engaged on magnetic and dielectric measurements of materials which looked promising for the design of a possible transatlantic telephone cable. This part of his career was brought to an abrupt end, however, when the Hendon Laboratories were shut down due to the economic depression in the '30s.

In 1933 a Special Competition was held for entry to the then Assistant Engineer grade for candidates from Industry, and Dr. Brockbank was one of five officers selected. He started in Research Branch in March, 1933, working on carrier systems applied to land and submarine cables. He was one of the first Post Office engineers to study the "new" feedback amplifier principles. In this year he obtained his Ph.D. for a thesis on Intermodulation in Ferromagnetic Materials.

## Book Review

"Gearing for Small Mechanisms." W. O. Davis. N.A.G. Press, Ltd., London. 157 pp. 76 ill. 25s.

To those interested in the manufacture of small mechanisms involving gearing this work provides a wealth of information on a subject about which little has been written. It is in simple and easily understood language with a minimum of trade jargon.

The reason why a modified cycloidal gear tooth form is used in the horological trade is not always obvious to the engineer accustomed by long usage to the involute form. In this work the author makes clear why this is done in the case of "going

In 1935 Dr. Brockbank transferred to the Radio Branch to develop the repeater equipment for the first London-Birmingham Coaxial Cable. This was a very big undertaking in those days, but in spite of the great difficulties the system went into traffic in 1938 and is still working. From 1938 to 1947, as an Executive Engineer, he was engaged in work on standardised coaxial line equipment, but promotion to Assistant Staff Engineer in 1947 brought him back to Research Branch where he dealt, amongst other things, with submerged repeaters and television transmission over coaxial pairs. Both expanded so much however that eventually he shed everything except submarine cable work.

Dr. Brockbank has been a liberal contributor to this Journal, on coaxial transmission, and with Mr. Floyd read a paper on Wideband Transmission before the I.P.O.E.E. Probably his most widely known work is that forming the basis of an I.E.E. Radio Section paper, with Mr. Wass, "Non-linear Distortion in Transmission Systems."

His single-minded interest in the work for which he is responsible, his unassuming manner and considerable technical ability, combine to make him eminently suitable to lead a team engaged on important research and development work. Submarine systems probably more than any other branch of transmission call for attention to detail at every stage. In his quiet and careful way Dr. Brockbank will be able to command this supreme effort from his staff and he has our best wishes in full measure in the responsibilities which he has now assumed.

H. W.

## I.P.O.E.E. Appointments

We record with pleasure that the Engineer-in-Chief has appointed Col. J. Reading, M.B.E., Assistant Engineer-in-Chief, to be Chairman of Council of the Institution of Post Office Electrical Engineers. In addition, he has been appointed Chairman of the Board of Editors of the Institution's Journal in succession to Mr. H. Faulkner, C.M.G., whose retirement was announced in the last issue.

To both posts he brings a wide fund of experience of the Institution's activities, having served in the past for many years both as Secretary of the Institution and as Managing Editor of its Journal.

This valuable background combined with his energetic and direct approach to problems leaves us in no doubt of the success he will achieve in the new appointments.

## Productivity Team Report

In the April, 1953, issue of the Journal reference was made to the visit to the U.S.A. of a Post Office specialist team, under the auspices of the British Productivity Council, to study telephone exchange maintenance in the Bell System and independent companies.

The Team Report is now available at 5s. 6d. per copy, post free, and copies can be obtained from the publishers. The British Productivity Council, 21 Tothill Street, S.W.1.

train" gears and deals at some length with the theory of various tooth forms.

No mention is made in the chapter on "Worm gearing" of the method of hobbing worm wheels by means of a fly-cutter. This is a cheap and effective way when small numbers are involved but, as with normal hobbing, requires the use of a tangential feed attachment on the hobbing machine.

The author has condensed into a small volume the results of, obviously, a considerable amount of practical experience. He has produced a unique work which, although written chiefly from the point of view of the watch and clock trade, nevertheless contains much that will interest those concerned in the manufacture of larger gears.

O. W. G.



# Regional Notes

## London Postal Region

### MOUNT PLEASANT PARCELS OFFICE POWER-OPERATED PLOUGHS

Following the success of the experimental power-operated parcel plough at the Mount Pleasant Sorting Office, which was comprehensively described in the JOURNAL,\* it was decided that the northern section of the glacia should also be mechanised. The weight of Christmas parcel traffic has been steadily increasing in recent years, and it was considered desirable to extend the glacia in conjunction with the work of mechanisation. The respective lengths of the north and south sections of the glacia are now 82 and 58 ft.

The second plough, which was brought in to operational service on the 2nd November, 1953, is identical to the original, except that the speed of traverse has been increased from 22 to 28 ft. per minute. In case of breakdown, provision has been made for parking the plough in a bay at the northern extremity of the track, and a hand-operated plough can then be brought into emergency use. Similar facilities were provided for the southern plough, but as yet, this service has not been required.

The control unit on the floor of the sorting office has been duplicated, and the postal supervising officer is able to regulate automatically the flow of parcels to any part of the glacia. Warning lights on the loading bank and also above the conveyors, indicate when a band is not in use.

As it only needs one man to operate the two ploughs, there has been a saving in staff over the old method of hand operation, and in addition to providing a much better distribution of parcels over the storage glacia, the power-operated ploughs have proved to be a sound financial proposition.

A. C. M.

\* P.O.E.E.J., Vol. 44, p. 61.

## North-Western Region

### BROUGHTON (MANCHESTER) EXCHANGE TRANSFER

The Broughton (Manchester) director exchange was brought into service at 1.0 p.m. on Saturday, 28th November, 1953, replacing the C.B. No. 10 exchange which had been in service since 1924. The transfer involved 1991 subscribers and 268 junctions. It was the first director exchange to be opened in the Manchester director area for ten years, and the exchange replaced was one of Manchester's three manual exchanges with C.C.I. working. The transfer followed conventional methods.

With two exceptions, the junction routes in and out of the automatic exchange were provided as completely new circuits. Prior to the transfer, calls originating at the thirty-two exchanges in the Manchester director area were routed into the old exchange to be completed via the C.C.I. positions. It was necessary, therefore, to arrange for the director translations at these outstations and the 7-digit senders in Toll exchange to be changed at the precise time of transfer so that calls from these exchanges could be routed over the new junction routes. This was done by modifying about half of the group-two directors and 7-digit senders on the morning of the transfer immediately after the busy hour and busying the directors and senders which were inappropriate.

The transfer of the call offices was begun fourteen days before the main transfer. Each call office was completely re-equipped and then connected to the new automatic exchange. These call offices were given full facilities. Calls for all routes except subscribers on the old exchange were routed over the new junction routes. Calls in the latter category were routed into Tandem and thence over the existing Tandem-Broughton (C.C.I.) junctions for completion by the operator. This involved modifying temporarily the translations on a few directors in Broughton new automatic exchange. These directors were taken out of service at the time of the transfer and the translations restored.

All the subscribers circuits concerned in the transfer were routed via the new main frame and thence via break jacks and tie cables to the old exchange, about 200 yards away. At the time of the transfer, the heat coils on the old main frame were removed by means of nylon cords threaded behind

them; all the staff involved wore goggles as a protection against flying heat coils. Wedges were then withdrawn from the protectors at the new exchange to cut in the automatic equipment. A smooth transfer was effected.

G. F. T.

## LANCASTER EXCHANGE TRANSFER

The Lancaster manual exchange, which was a month short of its 31st "birthday," ceased to exist at 1 p.m. on Saturday, 23rd January, 1954, on conversion of the area to non-director working.

The opening ceremony was performed by the Mayor of Lancaster in the presence of the Regional Director, Chief Regional Engineer, Telephone Manager, and a representative gathering drawn from within the city and the neighbouring seaside town of Morecambe.

During the official lunch, which took place immediately following the transfer, the Mayor originated a call to the Mayor of Lancaster, Pennsylvania, U.S.A., who has visited the English Lancaster. With the co-operation of the Engineering Department an amplifier and headphones were provided so that other members of the party and the press were able to listen-in to both sides of the conversation.

Despite storms and floods during the preceding week, which caused a considerable number of main cable and subscribers' faults, the transfer was accomplished with very few faults.

The new exchange has a 3,700 multiple and has a numbering range from 2,000 to 5,699. A total of 511 trunks and junctions are connected to it. The switchroom is decorated in pastel shades and is equipped with 46 manual positions furnished in light oak.

The official P.B.X., call offices, and the 12 U.A.X.s (12, 13 and 14) for which Lancaster is the parent exchange, were connected to the new exchange some three or four weeks in advance of the main transfer. The pre-transfer of the junctions enabled "0" level calls to be handled on the new A/M suite but full tandem dialling by the U.A.X. subscribers did not come into operation until the main exchange transfer. The new guarded metering routes to manual exchanges were also ready well in advance, and this enabled the tandem dialling arrangements to be tested out with the least possible interruption to the service. To carry the traffic between the old and new exchanges 80 transfer circuits (40 in each direction) were provided.

The whole of the transfer arrangements worked very smoothly, and thanks are due to the department's staff who worked so hard to ensure the success of the undertaking, and to Ericsson Telephones Ltd. who installed the main exchange equipment, which at the transfer and since has behaved admirably.

J. N. L. A. T.

## Midland Region

### SEVERE ELECTRICAL BURN-OUT

On the afternoon of the 26th June, 1953, Nottingham was subjected to a violent thunderstorm and torrential rain, resulting in the flooding of several low-lying districts of the City, including the Wholesale Fruit Market. Later that night (10.40 p.m.) congestion was reported on the Central exchange, and it was obvious that the underground cables serving the south-eastern districts were all faulty. Early morning location of the trouble was comparatively simple, since a close study of the underground distribution diagram showed the affected area to be fed by the Wholesale Fruit Market D.P.s, which in turn pointed to faulty cable lengths located on the south side of the same Market.

That there was some abnormal circumstance became apparent when sub-location within the faulty lengths was attempted, as not only were a large number of pairs earthing, but continuity could not be maintained between the ends. On learning from local enquiries that a nearby consumer was without D.C. power, electrical tests were made on the Post Office cables, and a P.D. to earth was recorded. With these results some concern was felt for the state of the two C.I. pipes in the footway, especially since draw-over operations were contemplated. A decision was therefore made to use a length of 600 pr. cable (held locally) to interrupt, overground, the six cables involved, and restoration of the telephone service commenced.

In the meantime, co-operation from the District Engineers of the East Midlands Electricity Board was requested and was immediately forthcoming. Probe tests over the fault area, together with isolation of the D.C. mains, indicated a breakdown position for the faulty D.C. cables. Excavation by E.M.E.B. workmen revealed the copper conductor carrying the positive of the 200/400V three-cable D.C. system exposed to earth in a gap of approximately 2 in. where the lead, jute serving and steel armouring had been burnt away. Later events were to reveal damage to P.O. plant far worse than was at first estimated. The first cable to be withdrawn after interruption overground was a single 200 pr. in the roadside C.I. pipe. Examination of this showed that the lead sheath had melted every few feet along its entire length and the molten lead had run along the C.I. pipe leaving the cable core exposed in many places. A large number of conductors had been burnt through, the whole cable being saturated with water. In addition, the remainder of the cables withdrawn

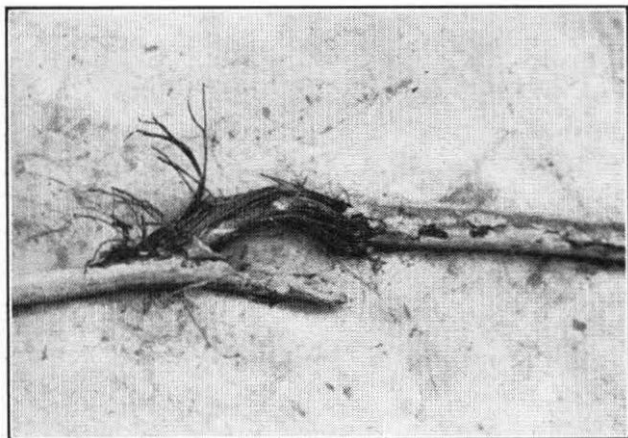

SPECIMEN OF DAMAGE TO CABLE.

from the other C.I. pipe were completely fused together. Further excavation revealed a hole burned through the pipe, the edges of which were fused to the disconnected end of the D.C. mains positive cable on the consumer side. The copper conductor on the supply side had fused back up the lead sheath and steel armouring. Some idea of the heat generated at this point could be obtained by examination of the samples, which showed that small stones had become fragmentary and embedded in the molten mass of cast iron, lead, copper and steel.

From information subsequently received, it was learned that at 9.0 p.m. on the 26th June, 1953, a positive D.C. mains over-load to earth was registered on the meters of a local sub-station, and a leakage of between 500 and 1,000 amps. was recorded.

The final repair to the Post Office conduit was made by renewing a section of C.I. pipe with a length of split pipe fitted with collars. Jointing operations on the renewed lengths concluded with the restoration of the Post Office plant to normal on Friday, 3rd July, 1953. T. H. C.

#### EXCESSIVE HUMIDITY AT BIRMINGHAM

Exceptional weather conditions were experienced in Birmingham during the period 1st to 18th December, 1953, when the relative humidity was greater than 97 per cent. and this resulted in an abnormal number of subscribers' faults being reported.

The air was practically static and the atmospheric dust formed on overhead plant became saturated causing large numbers of low insulation faults. Terminal blocks suffered from condensation effects during the cold nights and internal subscribers' apparatus located in unheated accommodation was similarly affected.

Although these conditions are frequently met in some coastal areas it is very unusual for Birmingham and in this densely telephoned area the results were serious. The graph shows the fault situation during the period as compared with the normal level of outstanding faults.

R. A. C.

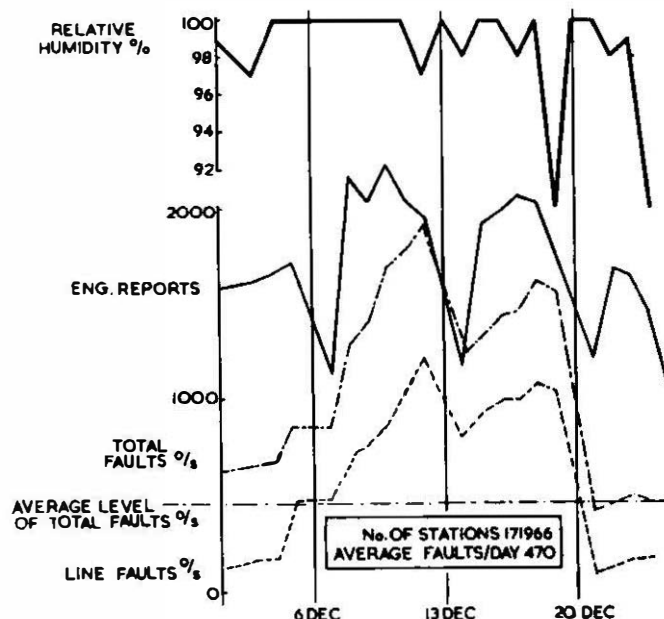

#### London Telecommunications Region TRUNK MECHANISATION

The first switching unit in the new system was opened to traffic on the 27th February, 1954, when London Trunk Faraday non-director exchange commenced to switch trunk traffic which originated in the London Group. This completes the first of two stages of the exchange contract and constitutes the Outgoing-from-London automatic routing; the second stage now in course of installation will in due course be opened to automatically route incoming traffic to the London Group.

Situated on the first floor of South-East Block of Faraday Building, the new plant comprises 182 racks of motor-uniselectors and 128 racks of incoming and outgoing relay sets for signalling routes as follows:—

Outgoing trunk circuits:— A.C. 1 with regenerators, A.C. 3, D.C. 1, D.C. 2, C.B.

Bothway trunk circuits:— A.C. 1, D.C. 2.

Automatic routiners are provided not only for the motor-uniselectors and relay sets, but also for the outgoing trunk and junction circuits. The trunk circuit automatic testing involves the actuation of the distant exchange terminal equipment from which a signal is received to prove the circuit and actuate the routiner for subsequent operations. All routiners are connected to automatic fault recorders each of which can be associated with a maximum of 16 routiners.

Other contract work co-ordinated with this exchange includes the provision of junction and trunk M.D.F.s on the ground floor of the South-East Block, each to the capacity of 226 verticals, and the installation on the 3rd floor of new trunk and junction test rack suites as follows:—

Junction test racks	.. .. .	11 Racks.
Trunk	.. .. .	28 Racks.
Trunk Circuit Busing Equipment	.. .. .	10 Racks.
Miscellaneous Fault Tables	.. .. .	4 Tables.

The switching capacity of the new exchange when Stage II is completed will be 5,000 incoming and outgoing trunk circuits and approximately 5,000 junctions.

Verbal delay announcements are given via late-choice outlets of the motor-uniselector, to which connection is made when the V.D.A. equipment is switched into service. When this equipment is inoperative the selector steps to an outlet connected to busy signal.

The initial manual board traffic is switched to the manual room in Faraday Building, South Block, 5th Floor, and delay booking is controlled in the 6th floor switchroom.

The power plant for the South-East Block already serving TOLL A & B auto exchanges had been developed to meet the ultimate load of this Block.

This contract was executed by Standard Telephones & Cables Ltd., who installed motor-uniselectors of Siemens'

design manufactured by the Automatic Telephone and Electric Co. Ltd., and also A.C.I relay sets with regenerators manufactured by the same contractor. The project has been executed under pressure of time in order that further stages of trunk mechanisation elsewhere should not be delayed.

F. V. P.

#### THE FIRST TIMBER U.A.X. BUILDING IN THE L.T.R.

The first standard timber U.A.X. building in the L.T.R. has recently been erected at Headley, near Epsom, Surrey. It is a "B.1" building to house a U.A.X. 13, replacing the now exhausted U.A.X. 5 which has been in service since the 29th November, 1932, and is the last U.A.X. 5 left in the L.T.R. The contract for the erection was let to Bath & Co. Ltd., who are the suppliers of these buildings. The site work was commenced on the 14th August, 1953, and the building was completed on the 12th October, 1953.

The cost of the building including the preparation of the site was substantially less than the estimated capital cost of a normal brick building on the same site.

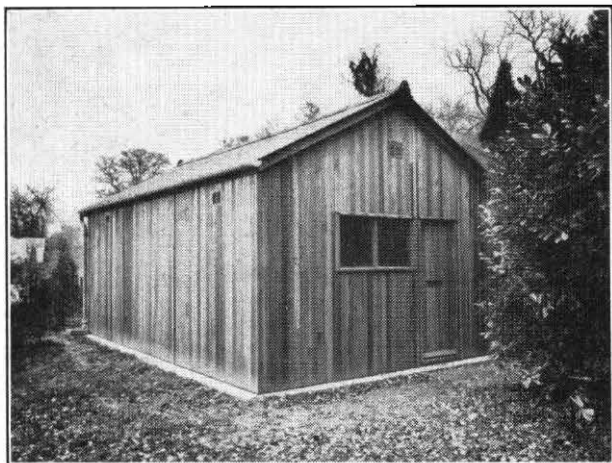

STANDARD B1 TIMBER U.A.X. BUILDING AT HEADLEY, NEAR EPSOM.

The whole building is of red meranti, the external cladding being tongued and grooved, with sisal kraft between the cladding and framework to prevent the penetration of rain. After erection the building is lined with foil-backed plaster board, spaced a few inches from the external boarding, to improve heat insulation, and the plaster-board is painted cream. The effect is more pleasing from an aesthetic point of view than fair-faced brick-work, which is normal for this class of building. In order to meet the wishes of the local authorities it was necessary to colour the corrugated asbestos roof; the paint used for this purpose was supplied by Tretol Ltd. The maintenance of the building consists of an occasional coating of linseed oil. The result is pleasing and it is hoped will prove satisfactory for many years to come.

W. J. B.

#### MODIFICATIONS TO LONDON TOLL B EXCHANGE

An automatic switching unit known as Toll B Director Faraday was brought into service on 27th June, 1949\* for handling traffic to the London director area from exchanges in the surrounding 12½- to 20-mile belt.

Initially all this traffic was operator-dialled, but within a few months of the opening of this unit, subscriber-dialling was introduced from Waltham Cross non-director exchange, to exchanges within the London director area five mile circle. This facility was subsequently extended to a further 16 non-director exchanges in the 12½- to 20-mile belt around the director area.

As full multi-metering facilities are not yet available at non-director exchanges, subscriber-dialling via Toll B has to be limited to exchanges within the director area five-mile circle, in which all exchanges are the same fee from any non-director exchange.

The subsequent introduction of 800-code multi-metering equipment at "fringe" non-director exchanges would have enabled subscriber-dialling to be extended to any director

exchange within fourth fee range, but it has been decided that full multi-metering at non-director exchanges should preferably be provided by register translator equipment at these exchanges.

As this register translator equipment will incorporate both multi-metering and route translating facilities, it was considered to be undesirable and unnecessary to pass calls through translating equipment successively at non-director exchanges and at Toll B. It was therefore decided that the next extension to Toll B should be a non-director switching component.

From the diagram, which shows the method of combining the non-director component with the existing director equip-

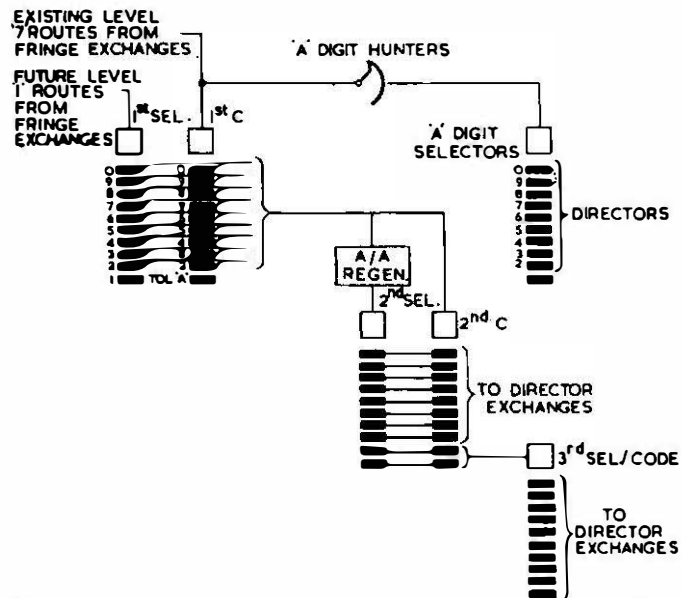

TRUNKING OF CONNECTIONS BETWEEN DIRECTOR AND NON-DIRECTOR EQUIPMENT.

ment, it will be seen that outgoing routes from 2nd-code selectors can be teed to the corresponding 2nd-selector levels of the non-director component. Further, at the third switching stage a common group of selectors can be used to serve both director and non-director components.

This non-director component is to be used initially for operator dialled traffic thereby enabling the director component to take the growth of the subscriber-dialled traffic on level 7.

By trunking level "1" of the Toll B non-director first selectors to Toll A first selectors, situated on the same apparatus floor, junction economies can be secured on routes incoming from manual boards in the "fringe" area that at present are provided with separate routes to both Toll A and Toll B. The provision of this connecting level between the two Toll exchanges will enable these manual boards to pass all traffic over combined Toll A—B routes.

This non-director extension to Toll B, which should be ready for service by May, 1954, is therefore the first stage of a complete "turn round" of this unit to non-director working. The final stages of the "turn round" will however, not be possible until all non-director exchanges, having access to the director area five-mile circle exchanges, are equipped with register translators.

C. G. G.

#### CONVERSION OF TUDOR EXCHANGE TO AUTOMATIC WORKING

Tudor exchange was one of the last manual exchanges to be built in the London area. It was opened in 1928, about one year after Holborn automatic exchange. Situated at Muswell Hill, N.10, the exchange served a large residential area of North London including parts of the Boroughs of Hornsey, Finchley and Wood Green and part of the Urban District of Friern Barnet. It was a Peel-Connor C.B.1 40V exchange and by the time it closed the exchange served about 8,000 subscribers and had 26 A positions, 5 B positions and 7 C.C.I. positions.

Provision of equipment for the new automatic exchange was

\* P.O.E.E.J., Vol. 42, p. 176.

delayed for several years because of the general economic situation, but in November 1952 the G.E.C. commenced the installation of a 10,000-line unit (9,420 calling equipments) and by intensive effort the exchange was ready for service in just over a year.

The cut-over was made at 1.30 p.m. on Thursday, 14th January, 1954, and on the following Tuesday a reception was held at The Athenaeum, Muswell Hill, to mark the occasion. The chair was taken by the Telephone Manager, Mr. E. E. Neal, and the guests included Mr. David Gammans, Assistant P.M.G., Mr. F. I. Ray, Regional Director, Mr. W. S. Procter, Chief Regional Engineer, the Mayors of the Boroughs of Hornsey, Finchley and Wood Green, the Chairman of the Urban District of Friern Barnet, other local Council officials, representatives of the Chambers of Commerce and local press and Post Office representatives. Speeches were made by Mr. Gammans and Sir William Grimshaw (Mayor of Hornsey) and the speakers were thanked by Mr. Ray. A demonstration of automatic telephone working was then given with the aid of a demonstration set representing Tudor exchange, the adjacent Mountview exchange and the manual board at Gulliver. After tea the guests were escorted round Tudor exchange by the engineering staff of the exchange.

### Home Counties Region

#### FURTHER LAND SLIP BETWEEN EAST GRINSTEAD AND FOREST ROW

In the Regional Notes of July 1953\* reference was made to a land slip which had occurred on the A22 road between East Grinstead and Forest Row. A second, and more serious one took place in October 1953 following a period of heavy rain. The actual cause of the slip has not yet been determined, but the theory of the road authority is that it is due to water from an unknown source causing a stratum of Tunbridge Wells sand to slide over one of Wadhurst clay. Following the advice of a water diviner, headings are now being driven into the embankment on which the road is built in an endeavour to locate the water and pipe it away. The highway authority has, however, intimated that it will take from three to five years for the embankment to achieve complete stability; in the meantime the voids under the road are being filled with grouting as they occur.

It was apparent that the Post Office plant, consisting of 7 ducts and 5 MU and CJ cables, was in continual danger, and as there was no stationary object to which it could be anchored, it was decided to interrupt the affected section by laying 5 armoured cables over a circuit long enough to avoid the Council's operations and the sites of possible future works.

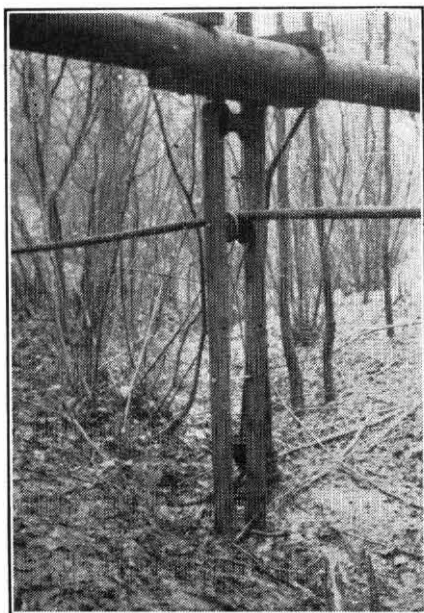

DEVICE TO LIMIT MOVEMENT OF PULLING ROPE AND, LATER, TO SUPPORT WEIGHT OF CABLE.

The laying of heavy cables over a distance of 370 yards across a 45 ft.-deep valley covered with coppice and traversed by a stream proved a most interesting and unusual task. The many difficulties were obvious to all the staff engaged on the work, each of whom contributed his quota of ideas. A speaker circuit was laid through the woods, so that the officer in charge could be simultaneously in touch with the drum end, the winch end and intermediate points along the track. Owing to the nature of the ground, the full length of cable had to be pulled over from one end, and the largest cable, 4 S.P. 40 + 270/25, having a diameter of about 3 in. required two motor winches in parallel. A large number of cable rollers were used in order to follow the track, which was tortuous in both vertical and horizontal planes. The first illustration shows one of the devices, which was necessary to limit the upward movement of the pulling rope initially and to carry the weight of the cable later.

Fortunately the weather held during the operation and a total of 628 pairs was changed over at each end without serious trouble.

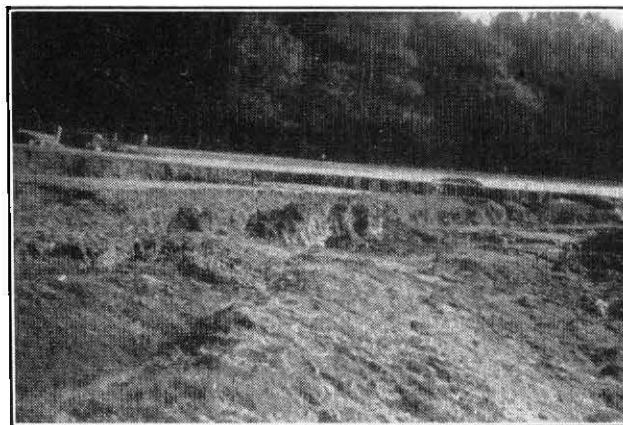

THE EMBANKMENT ONE WEEK AFTER STARTING TO SLIP.

The embankment one week after it started slipping is shown in the second illustration. L. W. B.

#### POLYTHENE PLUS ALUMINIUM CABLE

A 500 yard length of an experimental type of cable was recently installed in the Canterbury Area. The cable has a sheath of polythene and its core, containing 54 pairs in quad formation, has paper-covered conductors made of aluminium. The wires are 0.044 in. diameter, slightly less than the diameter of 40 lb. copper wire. The core is wrapped with two paper tapes followed by two aluminium tapes, each two mils. thick. The top tape is applied over the seams of the first one, and a thin layer of adhesive called "Vistac" is laid between the two tapes, with the object of providing a water vapour seal between the sheath and the core.

The recent work was confined to trying out the behaviour of the cable under normal drawing-in conditions and to jointing by Area staff. Short lengths of the cable were used for jointing practice and the rest of the cable was easily drawn into a duct containing lead-covered cables.

The cable is prepared for jointing in the normal manner by removing the plastic sheath and tying back the core and wrappings. The wires are jointed as for a normal type of lead-covered cable, except that the cut ends of the wire are welded on completion of the twist. The welding electrodes, which are connected to a 24V battery, consist of pliers which grip the lower end of the twist and an insulated tube which fits over the twisted ends. A momentary touch is all that is required by the insulated tube and no difficulty was experienced by local jointers in achieving satisfactory welds.

The cable joint is completed with self-sealing plugs fitted to the inside of a lead sleeve, the ends of which are reinforced with brass collars.

The installation of about ten miles of the cable on a junction route is expected to commence in the near future.

P. R. G.

\* P.O.E.E.J., Vol. 46, p. 98.



## MULTIPLE CONVERSION AT CRAWLEY EXCHANGE

The building of the New Town at Crawley is proceeding rapidly, and the demand for telephone service is expected to more than double the number of subscribers within the next five years, by which time it is hoped the new automatic exchange will be in service.

The present C.B. 10 exchange has a multiple of 1,600. The maximum multiple for such an exchange, on a four-panel repetition basis, is 2,000. By modifying the cornice of the positions and drilling the stile bars the multiple capacity can be increased to 2,800. By replacement of the four-panel multiple by one having a six-panel repetition, the maximum multiple can be increased to 4,200, although the full use of this at Crawley will be limited by the restricted accommodation, which will allow the present ten sections to be increased to twenty-five only.

The replacement of the existing multiple had to be proceeded with immediately rather than wait until further additions had been made, when the work would have become even more difficult, if not impracticable. This was an undertaking which had to be carried out on working equipment without interruption to the service and with a minimum of inconvenience to the operators.

The lacing of the existing multiple cables was cut between the cable turning section and the intermediate distribution frame. The cables were slung clear of the cable runway to make room for the new cable on existing cable racks and through the existing cable hole. The C.T.S. was moved sufficiently to allow a dummy section to be inserted at the non-growing end of the suite, equipped with multiple only, thus enabling the operator on the first position to have access to the whole six-panel multiple within normal reach.

The cabling from the I.D.F. to the C.T.S. for the new 1,600 multiple was run in its permanent position. The multiple for the first 600, already jacked, was gradually placed in the back of the switchboard behind the existing multiple. During the time when the new cabling was being connected to the jacks at the first appearance, the new cables were being permanently connected to the connection strips at the I.D.F., the old cables being teed in parallel.

On completion of this work, the existing four-panel multiple was lifted ten jack spaces higher in the switchboards, using old motor-cycle chains. These were suspended from specially made brackets bolted to the centre roof member of each position. Suitable bars inserted between the links allowed the working multiple to be supported in its raised position, while being kept in service.

The first 600 of the new multiple was placed in position, but not brought into service at this stage. This occupied a height of five jack spaces, thus leaving sufficient room for the next 600 to be dealt with on similar lines.

When completed, the first 1,200 lines, on a six-panel repetition, were brought into service leaving 400 on a four-panel basis. By cutting away the tees on the I.D.F. connection strips, 1,200 of the old multiple were thrown spare and recovered, while work was proceeding on the remaining 400 of the new multiple.

The overall period during which the operating staff was subjected to the inconvenience of using part six panel and part four panel multiple was one week only.

It is of interest to record that the whole of the cabling for the new multiple was carried out in "Cable Switchboard, 60 wire 9½ flat," thus making it possible to accommodate the ultimate multiple of 4,200 in the existing cable hole and cable racks and giving improved access to the jacks for maintenance purposes.

F. V. P.

## Scotland

### KIOSK ERECTION

For some years kiosks in Scotland West Area have been pre-assembled and have been carried to the erection site on the kiosk trailer. It was soon found that kiosks could not be erected and opened for service on the same day because of the time necessary for the cement floor to set, even although quick-setting cement was used.

To overcome this difficulty concrete slabs, 2 in. thick and 30 in. square with a 4-in. triangle cut off each corner to clear

the C.I. lugs on the kiosk, were obtained. These were specially made at a very reasonable price by a local firm. The slabs are fitted in the following way:

The base of the kiosk is filled to within 2 in. of the floor level with a fairly stiff mix of concrete, a wooden tamping rod, 2 in. square and about 30 in. long, is used against the door sill and the cast rebates on the other sides of the kiosk as a guide for the correct level for the concrete; a slight fall is given towards the door. When the concrete is reasonably accurate and level the slab is placed on edge in the doorway and is lowered by means of a loop of 70 C.C. or other similar scrap wire placed round the slab close to the cut-off parts at the back corners. The slab is bedded down by standing on it and working it until it is quite firm. The wire can usually be withdrawn if it is cut off close to the floor at one side, but if it resists, it is cut off close to the floor on both sides, and the ends are bedded in the cement mortar pointing which is then applied round the edges of the slab and in the corners.

It was found that different kiosks vary to within about ¼ in., and a very tight-fitting slab will not fit all kiosks, but a loose-fitting slab can be pointed and the pointing is not interfered

by people using the kiosk. It is known that some other Areas have experienced the same difficulty in erecting pre-assembled kiosks and it is thought that this method may be of interest.

W. W. M.

## North-Eastern Region

### DONCASTER—GRIMSBY COAXIAL CABLE, RIVER TRENT CROSSING

The cable laid by contract across the River Trent at Althorpe near Scunthorpe, is the largest coaxial subaqueous cable that has yet been laid in this country. (4 CX. pairs 375 E + 2/20 + 16/20 PCT + 288/20 PCQT subaqueous.)

The crossing was complicated due to the fact that half-tide walls were partly constructed along each bank of the river and it was necessary to dredge a channel through these walls before cabling could commence. (Half-tide walls, which comprise stone pitchings dropped into the river some distance from the actual bank, act as retaining walls and catch the silt which is washed up at high tides; the silt eventually forms a new river bank.)

Dredging operations, possible only at high tides, took about 14 days, approximately 75 tons of pitchings being removed.

The actual cabling operations were carried out on Wednesday, 17th February, 1954, and commenced about two hours before low tide. Two steam, agricultural-type, traction engines were used, each developing approximately 200 h.p. and giving a steady pull, one at either side of the river. The engine on the east side did the actual pulling, the second engine on the west side being used to keep the hawser taut and to pull back in case of any stoppage or obstruction.

The cable end was attached to a specially made bullet-shaped steel nose, which was free to revolve around the cable and forced a passage through the mud at the river bottom for the cable to follow, the hawsers to the two traction engines being attached to the nose. (A trial run, with the nose weighted down with chains, was made on the previous day to prove the route free from obstructions.) Pulling-in commenced at 1.19 p.m. and was completed by 1.32 p.m., the total length of the crossing being approximately 220 yd. No difficulties were encountered.

The shore ends of the cable were snaked as far as was possible between the water line at low tide and the terminating manholes.

Where the cable passes through the half-tide walls it has been protected by sacks of weak concrete mix, approximately 20 tons being used on each side of the river; the half-tide walls, which are to be made good by the River Authority, will eventually silt up and leave the cable buried some 15 to 20 ft. at either bank.

It is proposed further to anchor the cable at each end by fanning out the armouring wires inside the terminating manholes and embedding them in concrete which will be knitted to the walls of the manholes.

A reserve length of cable has been obtained for maintenance purposes.

H. E. H., J. G.

# Institution of Post Office Electrical Engineers

## Additions to the Library

- 2149 *Advanced Strength of Materials*. D. A. R. Clark (Brit. 1951).  
A continuation of the author's "Materials and Structures" (covering Pt. I of the London University Engineering Degree examination), the present volume covers the subject "Strength of Materials" at final degree level.
- 2150 *Worked Examples for Advanced Electrical Students*. D. I. Williams (Brit. 1952).  
For students having a sound knowledge of basic principles, and who require guidance in the solving of problems of the type set in papers for the H.N.C. in Electrical Engineering and Section B of the I.E.E. Associate Membership Examination.
- 2151 *Psychology in Industry*. J. S. Gray (Amer. 1952).  
An introduction to industrial psychology; includes all factors affecting men at work.
- 2152 *The Dimensioning of Engineering Drawings*. W. Abbott (Brit. 1953).  
Deals with the fundamental principles which apply to the dimensioning of drawings for engineering components in their finished state, in the manufacture of which interchangeability is a paramount requirement; with particular reference to the distribution of tolerances.
- 2153 *Technology of Engineering Materials*. B. R. Hilton (Brit. 1953).  
A description of pattern making and foundry work followed by the preparation, production and treatment of ferrous and non-ferrous metals.
- 2154 *Lenses in Photography*. R. Kingslade (Amer. 1951).  
Covers those aspects of lenses and photographic optics of interest to the serious amateur or professional photographer.
- 2155 *Principles of Electronics*. H. Buckingham and E. M. Price (Brit. 1953).  
Explains the general principles involved in the numerous and widespread applications of electronic devices; assumes the reader to be familiar with general circuit theory.
- 2156 *Microwave Lenses*. J. Brown (Brit. 1953).  
Intended primarily for radio engineers but worthy of study by physicists, particularly those concerned with artificial dielectrics and with diffraction phenomena.
- 2157 *Magnetic Amplifiers*. G. M. Ettinger (Amer. 1953).  
Intended to serve the practising engineer or physicist who wishes to select the most suitable device for performing a given measuring or control function; and as a starting point for the research worker.
- 2158 *Radio Communications*. W. T. Perkins and R. W. Barton (Brit. 1947).  
Prepared, to a large extent, for students who are interested in the City and Guilds of London Institute Examinations.
- 2159 *The M.K.S. System of Units—a Guide for Electrical Engineers* (Brit. 1953).  
A thorough explanation of the M.K.S. system of units, its use and its merits, with detailed methods of teaching the system to part-time and full-time students.
- 2160 *Principles of Electronics*. L. T. Agger (Brit. 1953).  
Should be useful to students preparing for the A.M.I.E.E., City and Guilds, Higher National Certificate and the external B.Sc. examinations, and to science students particularly interested in electrical technique.
- 2161 *Small Transformers and Inductors*. K. A. MacFadyen (Brit. 1953).  
Attempts to bridge the gap between conventional "theory" and the successful construction or application of a transformer by presenting on a common basis the general theory, the design procedures and the technical data for materials in common use.
- 2162 *Introduction to Valves*. R. W. Hallows and H. K. Milward (Brit. 1953).  
Describes the principles of operation of the radio valve and its uses in circuits of various types.
- 2163 *Mechanics via the Calculus*. P. W. Norris and W. S. Legge (Brit. 1950).  
Serves to bridge the gap between the elementary textbooks on the subject and the complete treatises which usually assume an advanced knowledge of the calculus.
- 2164 *Television Receiver Design: Flywheel Synchronization of Saw-tooth Generators*. P. A. Neeteson (Dutch 1953).  
A further volume in the Philips series of monographs. Gives an analysis of the flywheel action of resonant circuits, and a study of automatic phase control and a discussion of practical circuits.
- 2165 *Radio and Radar Technique*. A. T. Starr (Brit. 1953).  
A concise presentation of the essentials of modern knowledge of radio and radar, of value particularly to the younger less-experienced designer, and the advanced student.
- 2166 *Instrument Technology, Vol. 1: Measurement of Pressure, Level, Flow and Temperature*. E. B. Jones (Brit. 1953).  
A complete reference book on instruments and instrumentation which also covers the requirements for the C.G.L.I. Intermediate Examination in Instrument Maintenance.
- 2167 *A Practical Course in Magnetism, Electricity and Radio*. W. T. Perkins and A. Charlesby (Brit. 1948).  
Covers a variety of practical experiments designed to provide a sound knowledge of the fundamentals of electrical engineering and radio work.
- 2168 *A Class Book of Physics*. R. Gregory and H. E. Hadley (Brit. 1953).  
A general text-book to roughly matriculation standard.
- 2169 *Metalwork for Students*. R. Marriott (Brit. 1953).  
Provides the basic knowledge of elementary metallurgy, fitting, smithing, machine shop practice and decorative metalwork.
- 2170 *Soft Magnetic Materials for Telecommunications*. C. E. Richards and A. C. Lynch (Brit. 1953).  
Shortened version of papers discussed at an informal conference at the Post Office Research Station.
- 2171 *Television Engineering: Principles and Practice, Vol. 1*. S. W. Amos and D. C. Birkinshaw (Brit. 1953).  
A B.B.C. training manual covering fundamentals, camera tubes, television optics, and electron optics.
- 2172 *Principles of Transistor Circuits*. Ed. R. F. Shea (Amer. 1953).  
Attempts to gather under one cover a large portion of the volume of material which has been accumulated on the subject of transistor circuits—including fundamentals and an elaboration of various techniques in the field.
- 2173 *Essentials of Microwaves*. R. B. Muchmore (Amer. 1952).  
Presents the basic physical principles underlying the operation of all microwave devices in a relatively non-mathematical manner.
- 2174 *Faster than Thought: a Symposium on Digital Computing Machines*. Ed. B. V. Bowden (Brit. 1953).  
Descriptions of several of the machines, explanations of the way they work, and essays describing how they can be used.
- 2175 *Engineers as Writers*. W. J. Miller and L. E. A. Saidla (Amer. 1953).  
A study of the structure and style employed in reports by men of eminent engineering stature through the ages.

W. D. FLORENCE, Librarian.

# Associate Section Notes

## Birmingham Centre

Since the last notes membership of this Centre has continued to increase and has recently passed the 300 figure, standing now (February) at 305. While this is very encouraging to all concerned the average attendance at meetings is not as large as we, the officers and committee, would like; visits, however, are always over-subscribed and a very large number of members avail themselves of the circulation of periodicals.

An interesting evening during November was spent at a local camera shop examining equipment, seeing a 3-D demonstration film and viewing 3-D "stills" with various types of modern equipment. A second party will be spending a similar evening at the shop in the very near future. A visit was also paid during the same month to Fort Dunlop, when a party was conducted round the works and entertained afterwards; the evening was most instructive and was thoroughly enjoyed by all.

In December a member of this Centre, Mr. C. Morgan, who was one of the P.O. Productivity Team to visit the U.S.A. last year gave a talk entitled "My Impressions of the American Telephone Service." Much interesting information was obtained by those present and many searching questions were put to the speaker before the meeting was closed.

The City of Birmingham has, in the last few years, been forming a Museum of Science and Industry; the collection is quite extensive and includes not only models, but such items as an old steam roller, old fire engines, engines driven by gas and oil, numerous exhibits connected with electricity and our own industry, and also an arms section. A party was conducted round this museum by the keeper one evening during December and in addition to seeing the permanent collection also saw a special exhibition of clocks and watches, both old and new. The two hours spent going round passed all too quickly but was extremely interesting, and visitors to Birmingham are recommended to look round this museum which is almost next door to Telephone House.

A member of the Submarine Branch, Mr. G. Cottam, was good enough to travel here in January to talk to this Centre on "The Work of the Cable Ships." The talk was illustrated with lantern slides and samples of the cables used, and gave the members of this inland area an idea of what our colleagues in the cable ships have to do and the difficulties with which they have to contend. The most recent visit, which also took place in January, was to the Physics Laboratories of Birmingham University, when members were able to see the cyclotron and other research equipment.

The February meeting consisted of a film show arranged by the treasurer, when he presented two films entitled "The German A-4 Rocket" and "Rocket Instrumentation." These were a follow-up to his talk last session on Interplanetary Travel and attracted a gathering of over 50; the room was packed to capacity, by way of a change, and the evening was voted very interesting and instructive. K. G. S. A.

## Bournemouth Centre

This Centre was re-opened in November, 1952, after a lapse of about two years and a General Meeting was combined with a lecture and demonstration by K. A. Y. Russell on his television camera and associated equipment which has been mentioned in the "Wireless World." This was followed by visits to the new power station at Poole and to the Cable and Wireless station at Dorchester. In October we were fortunate to hear a lecture by Col. Calveley, O.B.E., on "Some Applications of Electronics." He was ably assisted by his demonstrators whose many pieces of equipment worked to perfection. Finally, in November a Grand Challenge Quiz Programme was held against the City Area of the London Centre and, during a most enjoyable evening, the Bournemouth team gained a narrow victory over their London opponents. This opportunity is taken of expressing thanks to all staff who contributed towards the success of the show and to the question-masters and adjudicators, Mr. Lee and Mr. Greening at London, and Mr. W. R. Tyson and Mr. Rushbridge at Bournemouth.

In the present year we hope to arrange a series of lectures and demonstrations by several of the members on their own

particular aspect of Telecommunications, and we hope that they will prove popular.

Other activities will be well advertised when they are arranged, and it is hoped that we shall see many new faces at our gatherings in 1954. P. M. K.

## Bradford Centre

The second half of our 1953-54 session started with a meeting to discuss future plans and to encourage members to present papers. Although Bradford has once again become a flourishing Centre with over 90 members, there seems to be little enthusiasm for this side of our activities. As a result our programme consists mainly of visits to industrial undertakings.

This last meeting was held on the 11th February, and the discussion was followed by a programme of films lent by the British Transport Commission. We are all now a good deal wiser about the problems of "Turn-round time" of ships at Hull and Ocean Terminal, Southampton.

On the 18th February, Mr. E. Hopkinson, Area Engineer, Bradford, read his paper on American methods of Step-by-Step Auto Exchange Maintenance to a well-attended meeting and the discussion which followed was of great interest to all present.

Programme for the remainder of the Session:—

25th March.—Visit to a steel works near Sheffield.

12th April.—B.I. Callender's Cable Works, Prescot, Liverpool.

20th May.—Locomotive Shops, Doncaster.

3rd June.—Annual General Meeting.

## Cambridge Centre

At the Annual General Meeting held on 8th April, 1953, the following officers were elected for the 1953-54 Session:—

*President*, Mr. W. E. Dance, Telephone Manager; *Chairman*, Mr. L. A. Salmon; *Vice-Chairman*, Mr. B. S. Cranfield; *Secretary*, Mr. J. P. Wearne; *Treasurer*, Mr. K. H. Phillips; *Auditors*, Messrs. L. W. Pooley and N. Radford; *Committee*, Messrs. J. E. Boon, B. Clark, H. W. Haworth and J. Henderson.

The programme commenced in October with a visit to Marconi's, Ltd., Chelmsford. In November, Mr. C. H. Hartwell, Assistant Engineer L.T.R., visited us to give his illustrated lecture, "The Development of the Telephone Business." To end 1953, a visit was made to the local British Portland Cement Works in December. The New Year commenced with a lecture by Messrs. L. Claydon and L. A. Salmon, "Development of 12- and 24-Circuit Carrier Systems," in January, and was followed in February with a lecture, "P.A.B.X.s," by Mr. F. Gresswell, Assistant Engineer, H.C.R. It was hoped that arrangements could be made to visit a local dairy in March and the session will conclude with the A.G.M. and film show.

J. P. W.

## Canterbury Centre

The Annual General Meeting of the Canterbury Centre was held at the Talisman Restaurant, Canterbury, on 7th May, 1953. Reports showed that the Centre was running in a satisfactory manner, membership having increased substantially during the year, reaching the figure of 120.

The following were elected as officers and committee:—

*Chairman*, V. Dungey; *Vice-Chairman*, L. J. Martin; *Secretary*, G. E. West; *Treasurer*, W. King; *Committee*, H. Marsh, C. Cox and P. O'Connor.

The guest speaker was Dr. I. E. Ryall (Deputy Regional Director) who gave a talk on past and future trends in telecommunications. The 80 members and visitors present sat down to dinner and were afterwards entertained.

1953-54 Session.—The first meeting was held in October. Mr. W. H. Scarborough gave a most interesting address and answered many questions relating to his duties as Telephone Manager.

"Photography—Producing the Print" was the title of Mr. E. C. Wilson's talk at the November meeting. His practical illustrations provided great interest.

A Speaking Contest took place during December. Seven entrants competed for a cash prize. It was won by Mr. G. Chalk who spoke on "Principles of Fluorescent Lighting."

At the January meeting a very pleasing ceremony took place. In the unavoidable absence of Mr. A. H. C. Knox, Mr. Scarborough (Telephone Manager) presented a member of the

Canterbury Centre, Mr. G. Chalk, with the certificate he was awarded in the 1952-53 I.P.O.E.E. Essay Competition. The presentation speech was recorded and the record has been given to Mr. Chalk. This was followed by a lecture and practical demonstration on "The Technique of Record Cutting," by Mr. W. Seymour.

Remaining programme items were:—

February.—"Drawing Office Procedure," by E. C. Tidball.

March.—"The Installation of a Coaxial Cable," by N. P. Gates.

The A.G.M.—date to be announced. G. E. W.

### Darlington Centre

The Session, well under way, can now be reviewed as to the progress made to date.

It is a pleasure to report that there have been increased attendances at the meetings, keen interest in the talks and a real enthusiasm shown in the discussions—more members are putting questions to the speaker instead of two or three individual members each posing several questions. The speakers have expressed their appreciation and are happy in the thought that their efforts have been worth while.

Senior Section meetings clash with the Centre meetings and it is unfortunate we cannot welcome the visitors we have had in previous sessions.

17th November, 1953.—The illustrated talk on "Plastics," by Mr. J. Wood, B.Sc., of Bakelite, Ltd., proved to be most educative and, due to the fact that many of the firm's products are supplied to the Post Office, much information was gleaned in the discussion.

17th December, 1953.—Mr. B. V. Northall (Senior Section) gave a talk on "Television" and members were impressed by his advanced knowledge of the subject.

Mr. Northall gained the National Award when he was a Darlington Centre member prior to his promotion to Assistant Engineer.

19th January, 1954.—Another illustrated talk: "The C.I.D.," was given by a Staff Officer from County Police Headquarters.

The speaker, with a thorough knowledge of police administration, described the organisation and the various methods employed in the detection of crime, and his listeners were much enlightened. The officer expressed appreciation of his reception.

16th February, 1954.—"The Area Engineer's Job," by Mr. F. W. Allan, A.M.I.E.E. (Area Engineer).

C. N. H.

### Edinburgh Centre

At the November meeting of the Centre the Chairman introduced Mr. A. Dunlop, a local schoolmaster, who gave his paper, "The Child at School," to a most interested audience. Afterwards he ably answered the numerous questions on what was definitely a most important topic.

That the subject, "The First Steps in Photography," chosen by Mr. W. F. Irvine for the January meeting, was indeed a popular one was indicated by the large attendance of members. This talk was illustrated by black-and-white and coloured slides prepared by the speaker, and the evening was voted a great success. The outdoor visit arranged for January was to a local glass works where the well-known Edinburgh crystal is made and an enjoyable evening was spent watching the expert craftsmen at work. There has been a most encouraging increase in the membership this session, and a welcome awaits anyone interested who would like to come to any of our meetings.

J. R. H.

### Glasgow & Scotland West Centre

The Centre has made an enjoyable start with the programme for the second half of the session. On Friday, 22nd January, 1954, a member, Mr. J. J. Brown, T.O., gave a talk on "Acoustics" which resulted in a considerable amount of discussion, not always relevant, but never uninteresting.

For the first visit of the New Year we were introduced to the Synchrotron, and some of the associated apparatus at the University by Mr. Atkinson and Mr. Robb, both of the Department of Natural Philosophy. A 15-minute discussion of the uses and basic principles of the synchrotron in nuclear physics stretched to 45 minutes and had reluctantly to be terminated in order to allow sufficient time to see all the

equipment. The 60 members who took part spent a fascinating afternoon in the realms of nuclear research and the 2½ hours sped all too quickly.

J. F.

### Kingston-upon-Hull Centre

This Session has been, up to date, a reasonably successful one, commencing in September, 1953, with a 16 mm. sound film show, the films in this case being lent by the Petroleum Film Board.

An inter-Section Quiz was held in October: Scarborough v. Hull. The Quiz was of a two-part nature—Scarborough winning the technical part and Hull gaining the victory in general knowledge.

Mr. Hill, of the B.E.A., gave us an extremely interesting talk on the Generation of the Public Electricity Supply, which was a great aid to those interested members who later paid a visit to the local power station.

In February, 1954, a paper was given by Mr. C. Buckle (York) on "Television." This talk was illustrated by Mullard film strips and T.V. demonstration.

Our present session ends with another Film Show in March of this year.

This Centre would like to express its thanks to the Kingston-upon-Hull Telephone Department for loan of public address equipment and tape recorders.

L. J.

### Lancaster Centre

An encouraging commencement has been made at Lancaster.

The inaugural meeting was held on 1st December, 1953, when guided by Mr. Triffitt, Area Engineer, Mr. Gould, Senior Section Secretary, and Mr. Roberts, Area Training Officer, a start was made.

The officers of the Centre are:—

*President*, L. A. Triffitt, B.Sc., Area Engineer; *Chairman*, C. Murray; *Vice-Chairman*, W. Briggs; *Secretary*, W.E. Greenwood; *Treasurer and Librarian*, E. Grundy; *Committee*, Messrs. Lytham, Fletcher, Ullock and Morris.

The programme, now nearing completion, included:—

6th January, 1954.—"The Origin and Problems of a Waiting List," by Mr. G. Thompson, Sales Superintendent, Lancaster.

11th and 12th January, 1954.—Conducted tours round the New Automatic Exchange, Lancaster.

10th February, 1954.—"Radio Interference," by G. C. Sumner, Assistant Engineer, Lancaster.

12th March, 1954.—"The Work of the Telephone Branch Laboratory," by M. Mitchell, B.Sc., A.M.I.E.E., Engineer-in-Chief's Office, London.

7th April, 1954.—Annual General Meeting.

### Leicester Centre

The winter programme for 1953/54 is now in full swing. The opening meeting of the session took the form of a long alley skittle match in which the Associate Section challenged local members of the Senior Section. The challengers lost the game by two legs to three so that the "Seniors" now hold the silver cup which was stored away during the war years and well nigh forgotten since! Good fellowship, however, far outweighed possession of the trophy itself. The meeting was well supported and a great success socially.

In December, a large party visited the Leicestershire County Police Headquarters. This proved an extremely interesting occasion and members dispersed with renewed admiration for the "Man in Blue." We commenced the New Year with a Travel Talk to which members were invited to bring their ladies. The lecturer gave an account of a holiday the previous year in Spain and the South of France. His informal comments on the photographic slides were appreciated by all, and had the most refreshing effect of bringing back holiday memories on a winter's evening.

Attendance at meetings generally is good, although a further increase in membership is hoped for. A "packed house" is a great encouragement to Secretary and Committee members alike. Further meetings have been arranged for the current session and it is hoped to make the summer programme as interesting as the one last year. We shall be pleased to welcome any of our colleagues who have not yet joined the Centre.

T. E. L.

(continued on p. 62)



# Staff Changes

## Promotions

Name	Region	Date	Name	Region	Date
<i>Asst. E.-in-C. to Dep. E.-in-C.</i>			<i>Tech. Offr. to Asst. Engr.---continued.</i>		
Mumford, A. H.	E.-in-C.O.	6.1.54	Simpson, A. F.	Mid. Reg.	23.11.53
<i>Dep. Director to Asst. E.-in-C.</i>			Hay, J. C.	Scot.	28.11.53
Booth, Capt. C. F.	E.T.E. to E.-in-C.O.	6.1.54	Forrest, A. L.	Scot.	30.11.53
<i>Staff Engr. to Asst. E.-in-C.</i>			Bush, S. J.	H.C. Reg.	1.12.53
Halsey, R. J.	E.-in-C.O.	3.12.53	Morris, I. C.	E.-in-C.O.	5.12.53
<i>Staff Engr. to Dep. Director</i>			Cotterell, F. W.	E.-in-C.O.	5.12.53
McMillan, Col. D.	E.-in-C.O. to E.T.E.	6.1.54	Causbrook, R. F.	E.-in-C.O.	5.12.53
<i>Dep. Ch. Reg. Engr. to Staff Engr.</i>			Dunkley, E. H. P.	E.-in-C.O.	5.12.53
Edwards, J. J.	L.T. Reg. to E.-in-C.O.	6.1.54	Sargeant, W. A.	E.-in-C.O.	14.12.53
<i>Asst. Staff Engr. to Staff Engr.</i>			McDermott, W. E.	N.Ire. Reg.	1.1.54
Brockbank, Dr. R. A.	E.-in-C.O.	30.12.53	Johnston, J. H.	N.Ire. Reg.	1.1.54
<i>Snr. Exec. Engr. to Asst. Staff Engr.</i>			Roberts, R. L.	N.W. Reg.	16.1.54
Brown, H. R.	E.-in-C.O.	4.1.54	Leach, R. L.	N.W. Reg.	20.1.54
<i>Area Engr. to Tel. Man.</i>			Williams, T. G.	E.-in-C.O.	21.1.54
Weaver, E. W.	E.O.D. (Sec.) to H.C. Reg.	1.2.54	Ridgway, W. L.	W.B.C. to E.-in-C.O.	20.2.54
<i>Exec. Engr. to Snr. Exec. Engr.</i>			Bryant, H. R.	S.W. Reg. to E.-in-C.O.	20.2.54
Atkin, E. W.	H.C. Reg. to Mid. Reg.	4.1.54	Ghent, K. W. A.	H.C. Reg. to E.-in-C.O.	20.2.54
Lamping, C. T.	E.-in-C.O. to W.B.C.	1.2.54	Hall, B.	N.E. Reg. to E.-in-C.O.	20.2.54
<i>Asst. Engr. to Exec. Engr.</i>			Forster, J. F. S.	N.E. Reg. to E.-in-C.O.	20.2.54
Bronsdon, E. G.	E.-in-C.O.	7.12.53	Priestley, W. D.	N.E. Reg. to E.-in-C.O.	20.2.54
Cummings, F. G.	E.-in-C.O.	11.12.53	Brown, G.	E.T.E.	11.5.53
Palmer, E. C.	E.-in-C.O.	11.12.53	Baldwin, I. H.	E.T.E.	11.5.53
Bulfin, A.	N.E. Reg.	29.12.53	Reeves, L. A.	E.T.E.	25.8.53
Goulden, C. J.	N.W. Reg.	11.1.54	Shires, N. N.	E.T.E.	25.8.53
Groome, J. S.	Scot.	27.1.54	<i>Asst. Engr. (Open Competition)</i>		
Chadburn, C. G.	E.-in-C.O.	1.2.54	Goodison, H.	N.W. Reg. to Scot.	5.1.54
<i>Exec. Engr. (Open Competition)</i>			Bartlett, G. A.	E.-in-C.O.	18.1.54
Scarborough, R. J. D.	E.-in-C.O.	3.12.53	Sergent, T.	E.-in-C.O.	25.1.54
<i>Inspector to Asst. Engr.</i>			Johnson, D.	N.E. Reg. to Scot.	14.12.53
Brignal, J. R.	N.W. Reg.	16.1.54	<i>Tech. Offr. to Inspector</i>		
Boyle, J.	N.W. Reg.	27.1.54	Spicer, J. A.	S.W. Reg.	8.8.53
Morgan, E.	N.W. Reg.	26.9.53	<i>Tech. I. to Inspector</i>		
Barrett, D.	L.T. Reg.	26.9.53	Simmons, L. G. A.	H.C. Reg.	27.6.53
Hall, W.	N.Ire. Reg.	14.10.53	Coleman, D. R. F.	H.C. Reg.	23.8.53
Offord, G. E.	H.C. Reg.	15.10.53	Marsh, E. C. N.	H.C. Reg.	3.6.53
Elliott, F. A.	L.T. Reg.	17.10.53	Wiseman, J. E.	N.E. Reg.	8.7.53
Gregory, A.	N.E. Reg.	18.10.53	Agnew, T.	N.Ire. Reg.	20.7.53
Howard, A.	L.T. Reg.	19.11.53	Poulter, R. V.	L.P. Reg.	14.9.53
Jones, W. E. R.	L.T. Reg.	20.11.53	Delaney, H. T.	N.E. Reg.	23.9.53
Ludman, W. G.	H.C. Reg.	22.11.53	Medford, G. J.	N.W. Reg.	1.10.53
Stubbs, R.	H.C. Reg.	23.11.53	Blizard, A.	N.E. Reg.	18.10.53
Canfield, W.	L.T. Reg.	7.12.53	Pierson, W. J.	N.Ire. Reg.	9.11.53
<i>Tech. Offr. to Asst. Engr.</i>			Ashton, J.	N.W. Reg.	16.11.53
Castle, C. G.	L.T. Reg.	20.7.53	McKenna, T. A.	N.Ire. Reg.	17.11.53
Dickson, J. A.	Scot.	30.9.53	Mann, J. F.	Mid. Reg.	30.11.53
Long, C. E.	N.W. Reg.	1.10.53	Gregson, J. L.	N.W. Reg.	25.12.53
Thornhill, S.	N.W. Reg.	21.10.53	Jones, J. R.	N.W. Reg.	28.12.53
			Edwards, R. L.	H.C. Reg.	29.12.53
			McCarthy, R. E.	N.Ire. Reg.	1.1.54
			Marsh, G. W.	H.C. Reg.	2.1.54
			Hague, C. A.	L.P. Reg.	11.1.54
			Beard, H.	Mid. Reg.	14.1.54
			McMaster, W.	N.W. Reg.	16.1.54
			Maine, H. D.	N.W. Reg.	27.1.54
			Taylor, J.	N.W. Reg.	11.2.54

## Transfers

Name	Region	Date	Name	Region	Date
<i>Power Engr.</i>			<i>Exec. Engr.—continued.</i>		
Burr, A. H.	N.E. Reg. to S.W. Reg.	1.2.54	Bidgood, D. F.	W.B.C. to S.W. Reg.	7.2.54
<i>Exec. Engr.</i>			<i>Asst. Engr.</i>		
Stewart, T.	E.-in-C.O. to E.T.E.	1.12.53	Kirby, H. V.	S.W. Reg. to Gold Coast	2.11.50
Thomas, H. C.	E.-in-C.O. to H.C. Reg.	2.12.53	Boon, J. W. H.	N.W. Reg. to N.E. Reg.	16.8.53
Bott, T. D.	E.-in-C.O. to H.C. Reg.	1.1.54	Abbess, J. L.	L.P. Reg. to L.T. Reg.	20.12.53
Abbott, P. W.	E.-in-C.O. to W.B.C.	1.1.54	Roberts, E.	E.-in-C.O. to H.C. Reg.	24.1.54

**Retirements**

Name	Region	Date	Name	Region	Date
<i>Dep. E.-in-C.</i>			<i>Asst. Engr.--continued.</i>		
Faulkner, H.	E.-in-C.O.	5.1.54	Hamblett, R.	H.C. Reg.	8.1.54
<i>Asst. Staff Engr.</i>			Thomas, E. L.	S.W. Reg.	19.1.54
Baker, T. W.	E.-in-C.O.	31.12.53	Leake, R. J.	N.Ire. Reg.	25.1.54
<i>Snr. Exec. Engr.</i>			Bacon, E. W.	L.T. Reg.	28.1.54
Jupe, A.	E.T.E.	31.1.54	Stewart, R. H.	L.T. Reg.	31.1.54
West, A. S.	S.W. Reg.	30.12.53	Williamson, A. A.	L.T. Reg.	9.3.54
<i>Exec. Engr.</i>			<i>Inspector</i>		
Smith, G. W.	H.C. Reg.	1.12.53	Sayer, J. F.	H.C. Reg.	30.9.53
Stevens, F. W.	S.W. Reg.	31.12.53	Brown, C.	N.Ire. Reg.	31.10.53
Theobald, H. A.	L.T. Reg.	31.12.53	Reason, W.	L.T. Reg.	1.12.53
Naylor, S. E.	H.C. Reg.	31.12.53	Parkes, E. J.	L.T. Reg.	13.12.53
Love, R. C.	Scot.	31.12.53	Kilvert, F. R.	N.W. Reg.	24.12.53
Harrison, J. M.	E.T.E.	31.12.53	Moore, W.	Mid. Reg.	24.12.53
Cohen, J. H. L.	E.-in-C.O. (Resigned)	18.12.53	Rowe, R. L.	H.C. Reg.	27.12.53
<i>Asst. Engr.</i>			Hill, R.	N.Ire. Reg.	31.12.53
Bedford, A.	L.T. Reg.	4.10.53	Urry, E. B.	H.C. Reg.	31.12.53
Edwards, G. R.	L.T. Reg.	13.10.53	Killoran, J. E.	N.W. Reg.	31.12.53
Orman, T. W.	L.T. Reg.	31.10.53	Walker, E.	N.W. Reg.	31.12.53
Banyard, S. C.	H.C. Reg.	31.10.53	Young, R. A.	H.C. Reg.	31.12.53
Bydowell, P. J.	L.T. Reg.	6.11.53	Jones, V. C. A.	L.T. Reg.	31.12.53
Harris, A. F.	E.T.E.	25.11.53	Stewart, J. O.	Scot.	31.12.53
Billson, A. C.	L.T. Reg.	8.12.53	Hawkings, A. E.	L.T. Reg.	18.1.54
Harvey, H. C.	N.E. Reg.	16.12.53	James, R. W.	L.T. Reg.	27.1.54
Denchfield, T. M.	L.T. Reg.	31.12.53	Goodwin, J. W. J.	Mid. Reg.	31.1.54
Jones, H.	N.W. Reg.	31.12.53	Collingbourne, H. L.	S.W. Reg.	17.2.54
Pettit, E. W.	E.-in-C.O.	31.12.53	Siddle, A.	N.E. Reg.	21.2.54
Parker, J.	N.W. Reg.	4.1.54	Hutchison, W.	L.T. Reg.	22.2.54
Richards, A.	W.B.C.	5.1.54	Dunning, W. H.	N.W. Reg.	24.2.54
Baxter, W. G.	H.C. Reg.	7.1.54	<i>Tech. Asst. I.</i>		
			Mitchell, A. F.	Mid. Reg.	12.12.53

**Deaths**

Name	Region	Date	Name	Region	Date
<i>Exec. Engr.</i>			<i>Inspector</i>		
Baird, E.	Scot.	16.12.53	Elgey, N.	N.W. Reg.	25.12.53
<i>Asst. Engr.</i>			Richardson, R. M.	Scot.	5.1.54
Hines, R. G.	E.T.E.	27.5.53	Mason, G. K.	N.W. Reg.	19.2.54
Watt, G. D.	E.-in-C.O.	21.12.53	<i>Tech. Asst. I.</i>		
Wade, W. G.	L.T. Reg.	26.1.54	Kimberley, R. G.	L.T. Reg.	2.12.53

**DRAUGHTSMEN**

Promotion			Death		
Name	Region	Date	Name	Region	Date
<i>D'man to Ldg. D'man.</i>			<i>Ldg. D'man.</i>		
Fuse, S. H.	S.W. Reg. to E.-in-C.O.	16.9.53	Morris, W. A.	E.-in-C.O.	2.10.53
Transfers			Retirements		
Name	Region	Date	Name	Region	Date
<i>D'man.</i>			<i>D'man.</i>		
Mead, S. R.	L.T. Reg. to E.-in-C.O.	2.11.53	Palmer, B. L.	E.-in-C.O. (Resigned)	30.10.53
Alford, S. B.	E.-in-C.O. to Fact. Dept.	16.11.53	Wilson, L. F.	E.-in-C.O. (Resigned)	20.2.54

### Middlesbrough Centre

At the time of writing these notes the Centre is more than half way through its winter programme and has heard a varied and interesting series of lectures.

On the 12th November, Mr. H. C. Naylor, a Senior Section member, paid a welcome return visit to the Centre with his paper, "Some Aspects of Electronics," when he explained some of the more unusual aspects of amplifier circuitry and the principles behind their design.

"Mechanical Aids," given by Messrs. G. R. Meggeson and M. Walker on the 10th December, was intended to be of particular appeal to the external members, but the lecture, with film strip illustrations, proved to be of real interest to all the members present.

On the 11th January, Mr. F. O. M. Grimshaw, one of our own members read his paper "Cables and Corrosion." This was Mr. Grimshaw's second paper given before this Centre and previously he had given several papers at Darlington. In his latest paper, which, as usual, attained the high standard he has set himself, he explained the dangers from, and the methods of protection against, chemical and electro-chemical corrosion in underground cable systems. The meeting ended in a lively discussion.

There will be two more meetings before the Annual General Meeting and it is confidently expected that Mr. K. Hamilton, who fills the vacant March date with "Modern Carrier Equipment," and Mr. D. B. Oliver on "The Jet Age," will complete a most successful session. The Annual General Meeting will be held on the 13th May, when the programme for the next session will be discussed, and it is hoped that all members will make an effort to attend and voice their suggestions or criticisms.

P. G.

### London Centre

Due to unforeseen circumstances the lecture programme for the past two meetings had to be altered.

On 28th January, Mr. H. G. Bassett, B.Sc., A.M.I.E.E., gave a lecture on "The Transistor and its Applications." After a brief history he went on to the construction and manufacture of the contact- and junction-type transistors. The application of transistors to various types of amplifier and oscillator circuits concluded the lecture. Afterwards the questions asked by members proved that it had been a very successful evening.

Owing to the illness of Colonel Wellingham the lecture subject for 18th February had to be changed. We were very fortunate to get Mr. R. W. Palmer, M.I.E.E., to lecture on "The Step-by-Step System in the U.S.A." Mr. Palmer was the leader of the Productivity Committee's team that visited the U.S.A. and was thus able to give a good description of the telephone systems in use there. Their organisation and maintenance procedure were next explained. The lecture concluded with details of the large amount of work that the companies over there are doing with respect to dust and its effect on the apparatus. The many causes of dust and their prevention have all been closely examined. Many excellent slides helped to complete a most interesting lecture.

The A.G.M. of the London Centre will once again be held at the I.E.E. Lecture Theatre on 26th May. Mr. F. I. Ray, President of the London Centre, will lecture on "This Telephone Business." As the title indicates he will cover the financial and business side of the service. As lectures on this are rare, members are advised to attend so that they can have the opportunity of hearing an interesting lecture given under the ideal conditions that this lecture theatre provides.

E. W. B.

### Correction.

It is regretted that the wrong caption was included with the photograph published on page 212 of the January 1954 issue. The caption should have read: "Presentation to Mr. W. J. Costello (left) by the Chief Regional Engineer."

### BOARD OF EDITORS

Col. J. READING, M.B.E., B.Sc.(Eng.), M.I.E.E., Chairman.  
W. WEST, O.B.E., B.A., M.I.E.E.  
L. F. SCANTLEBURY, Whit.Sch., A.C.G.I., D.I.C., M.I.E.E.  
D. A. BARRON, M.Sc., M.I.E.E.  
H. G. BEER, Whit.Sch., A.C.G.I.  
E. DAVIS, A.M.I.E.E.  
L. CHANT.  
G. E. STYLES, A.M.I.E.E., Managing Editor.  
W. A. HUMPHRIES, A.M.I.E.E.  
J. P. HARDING, B.Sc.(Eng.),  
A.M.Inst.C.E., A.M.I.E.E. } Assistant Editors.  
A. J. HUTCHISON, Secretary-Treasurer.

### Copyright

The entire contents of this JOURNAL are covered by general copyright, and special permission is necessary for reprinting long extracts, but Editors are welcome to use not more than one-third of any article, provided credit is given at the beginning or end thus: "From the *Post Office Electrical Engineers' Journal*."

The Board of Editors is not responsible for the statements made or the opinions expressed in any of the articles in this JOURNAL, unless such statement is made specifically by the Board.

### Communications

All communications should be addressed to the Managing Editor, *P.O.E.E. Journal*, Engineer-in-Chief's Office, Alder House, Aldersgate Street, London, E.C.1. Telephone: HEADquarters 1234. Remittances should be made payable to "The *P.O.E.E. Journal*" and should be crossed "& Co."

### Binding Cases

Cases for binding are available, and may be obtained from the Local Agents for 3s. Subscribers can have their copies of volumes bound, at a cost of 10s. 6d., by sending the complete set of parts to the Local Agents or to the *P.O.E.E. Journal*, Engineer-in-Chief's Office, Alder House, Aldersgate Street, London, E.C.1. Orders for binding for Vols. 1-19 should indicate whether the original binding case with black lettering, or the later pattern with gold, is required. Cases with gold lettering are the only type stocked from Vol. 20 onwards.

### Back Numbers

The price of the JOURNAL, which is published quarterly, is 2s. 6d. (2s. 9d. post free) per copy, or 11s. per annum, post free. Back numbers can be supplied, subject to availability of stocks, at 2s. 6d. each (2s. 9d. post free). Orders for back numbers may be sent to the *P.O.E.E. Journal*, Engineer-in-Chief's Office, Alder House, Aldersgate Street, London, E.C.1, or to the Publishers.

Employees of the British Post Office can obtain the *Journal* through Local Agents at the reduced price of 2s. per copy.

### Advertisements

All communications relating to space reservations should be addressed to the Advertisement Editor, *P.O.E.E. Journal*, Alder House, Aldersgate Street, London, E.C.1. Communications regarding advertisement copy, proofs, etc., should be addressed to the Publishers, Messrs. Birch & Whittington (Prop. Dorling & Co. [Epsom], Ltd.), 49 Upper High Street, Epsom, Surrey.

**INDEX TO ADVERTISERS**

	PAGE
Airmec, Ltd. . . . .	iv
Alton Battery Co., Ltd., The . . . . .	xxii
Automatic Coil Winder & Electrical Equipment Co., Ltd. . . . .	xiii
Automatic Telephone & Electric Co., Ltd. . . . .	xii, xxiv-xxv
Bennett College, The . . . . .	ii
British Electric Resistance Co., Ltd., The . . . . .	xxxii
British Institute of Engineering Technology . . . . .	iii
British Insulated Callender's Cables, Ltd. . . . .	xxi
Edison Swan Electric Co., Ltd., The . . . . .	xxxiv
E.M.I. Institute . . . . .	xxxiii
Ericsson Telephones, Ltd. . . . .	xv
Ferranti, Ltd. . . . .	ix
General Electric Co., Ltd., The . . . . .	xviii-xix
Great Northern Telegraph Co. Ltd. . . . .	xxx
Hackbridge Cable Co., Ltd. . . . .	iv
Hivac, Ltd. . . . .	iii
Jones, Walter . . . . .	xxxii
Marconi's Wireless Telegraph Co., Ltd. . . . .	v
Marconi Instruments . . . . .	vii
Muirhead & Co., Ltd. . . . .	xxxiii
Mullard, Ltd. . . . .	viii, xvi
Painton of Northampton . . . . .	x
Pirelli-General Cable Works, Ltd. . . . .	xxxiv
Pitman, Sir Isaac, & Sons, Ltd. . . . .	ii
Pye, Ltd. . . . .	xxvi-xxvii
Redifon, Ltd. . . . .	ii
Rees Mace Marine, Ltd. . . . .	vi
Siemens Brothers & Co., Ltd. . . . .	xi
Skillman, T. S., & Co., Ltd. . . . .	xx, xxxiii
Smith, Frederick, & Co. . . . .	xxxiii
Standard Telephones & Cables, Ltd. . . . .	xiv, xxviii-xxix
Sullivan, H. W., Ltd. . . . .	xxxi
Telephone Manufacturing Co., Ltd. . . . .	xiii
Tungstone Products, Ltd. . . . .	xvii
Turner, Ernest . . . . .	ix
Westinghouse Brake & Signal Co., Ltd. . . . .	xxxix

**SUB - MINIATURISATION**

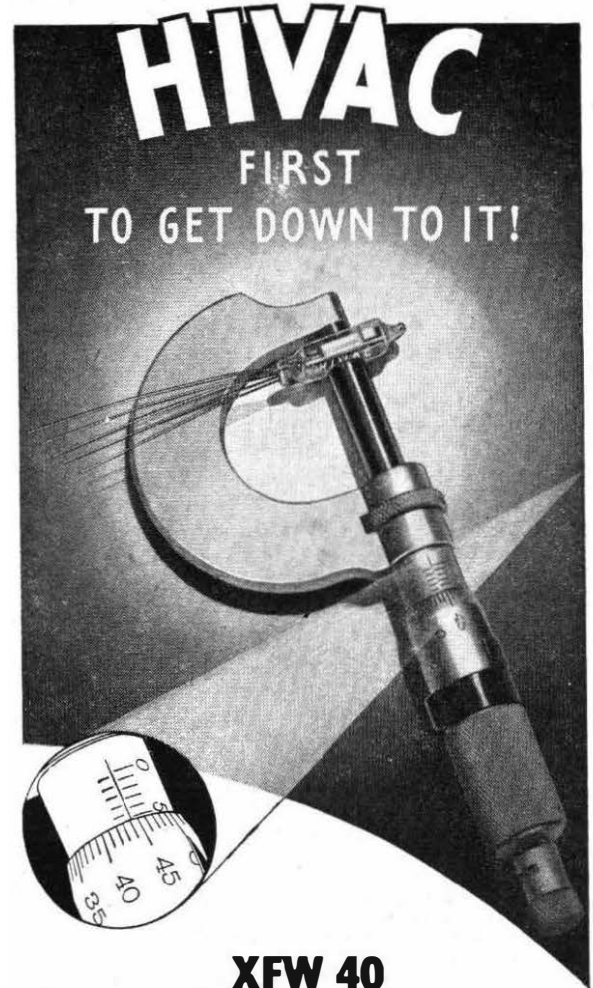

**XFW 40**

**Beam Tetrode Sub-Miniature Amplifier with still lower filament current**

**TYPICAL OPERATION**

Filament Voltage	... ..	<b>0.625v</b>
Filament Current	... ..	<b>10mA</b>
H.T. Supply Voltage	... ..	<b>22½v</b>
Anode Load	... ..	<b>1 to 2MΩ</b>
Screen Resistance	... ..	<b>3MΩ</b>
Stage Gain	... ..	<b>32</b>

The maximum cross-section is only 8mm. by 6mm. with a glass length of 27.0mm.



The most modern small flat sub-miniature voltage amplifier for hearing aids and other small electronic equipment.

**Hivac Ltd.**

Telephone: HARrow 2855  
GREENHILL CRESCENT, HARROW-ON-THE-HILL, MIDDLESEX

**VALUABLE FREE BOOK**

**Tells You How to Pass Your C. & G. or Promotion Exam. at First Attempt!**

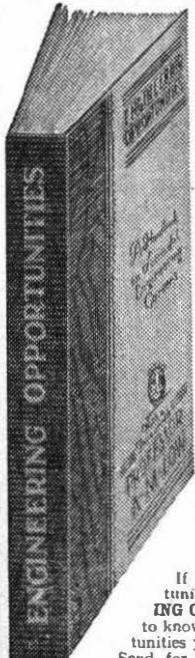

All Post Office Engineering personnel who are anxious to obtain early promotion should at once send for a copy of our handbook "ENGINEERING OPPORTUNITIES," which among other intensely interesting matter describes our unique methods of preparation for **TECHNICAL APPOINTMENTS IN THE POST OFFICE** (Assistant Engineer—New Style and Assistant Traffic Superintendent), **CITY AND GUILDS EXAMINATIONS** in Principles of Telecommunications (1-5), Radio (1-4), Telephone Exchange Systems (1-3), Telegraphy (1), Line Transmission (1 and 2), Lines Plant Practice (1 and 2), Mathematics for Telecommunications (1-5), Electrical Engineering Practice (Prelim. Inter. and Final), and outlines a wide range of non-examination courses in all branches of Electrical, Mechanical, Civil, Automobile, Aeronautical and Radio Engineering.

Assistant Engineer and Assistant Traffic Superintendent. Open competitions now resumed. Age extensions for established Civil Servants. Ask us for full details

**We definitely guarantee "NO PASS—NO FEE"**

If you intend to make the most of to-day's opportunities, you cannot afford to miss reading "ENGINEERING OPPORTUNITIES." It tells you everything you want to know to secure advancement, and describes many opportunities you may now be missing through lack of information. Send for your copy to-day—FREE and without obligation.

**BRITISH INSTITUTE OF ENGINEERING TECHNOLOGY**  
369 COLLEGE HOUSE,  
29-31 WRIGHT'S LANE, LONDON, W.8

**BIET**





# OSCILLOSCOPE

## Type 723

- Y Amplifier response flat from D.C. to 5 Mc/s
- Sensitivity of 100 mV per cm. at 1 kV E.H.T.
- No overloading occurs with full screen deflection over complete frequency range at 2 kV E.H.T.
- Variable E.H.T. voltages of 1, 2, and 4 kV
- Time-base range from 0.5 seconds to 1 micro-second for full screen deflection
- A deflection of 1 cm. ensures rigid synchronisation over whole frequency range
- Versatile Auxiliary Amplifier incorporated
- Automatic Brilliance Control Circuit
- Instantaneous shifts

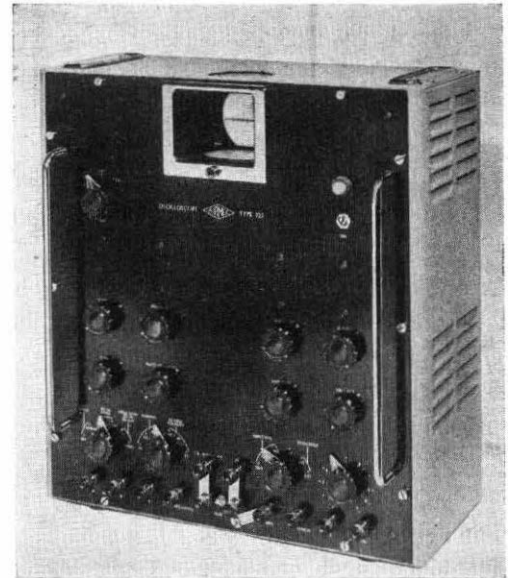

Full details of this instrument, which is available for immediate delivery, will be forwarded gladly upon request

**AIRMEC**  
L I M I T E D

HIGH WYCOMBE

BUCKINGHAMSHIRE

ENGLAND

Telephone: High Wycombe 2060

Cables: Airmec, High Wycombe

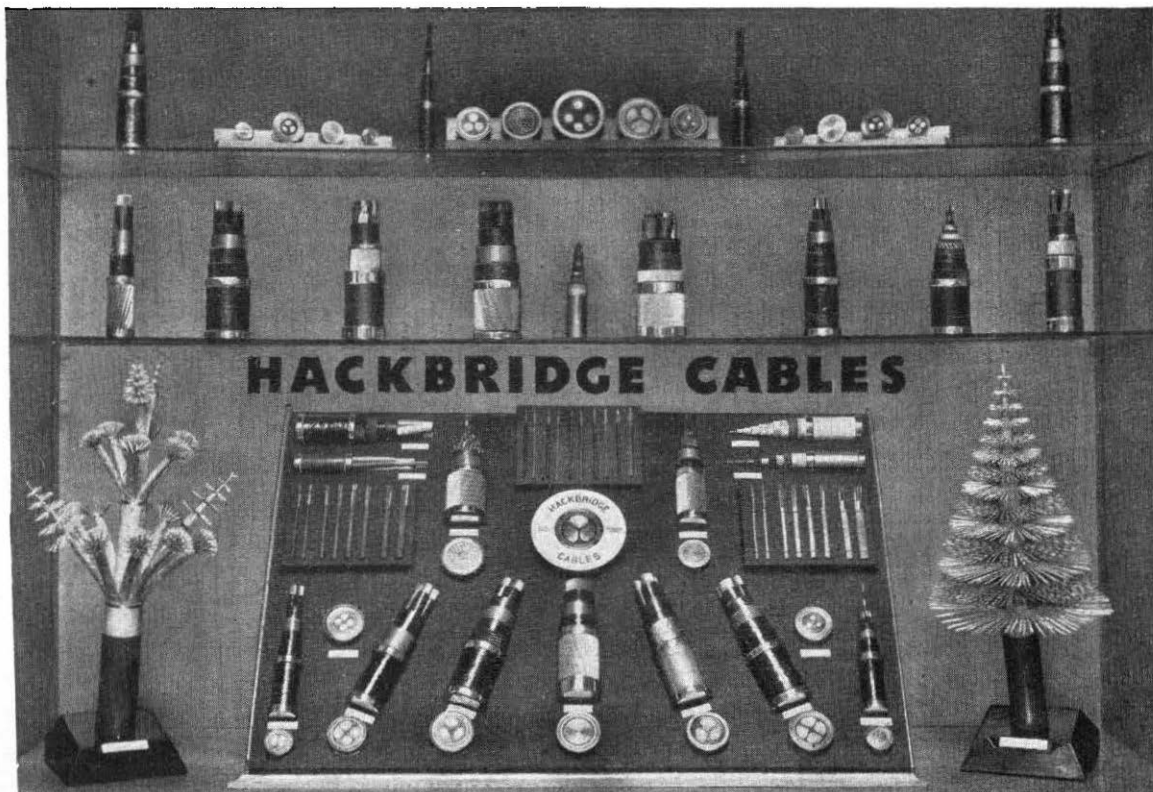

**HACKBRIDGE** KELVIN WORKS, HACKBRIDGE, SURREY  
*Cable Company Limited* In Association with BRYCE ELECTRIC CONSTRUCTION Co. Ltd.,  
 Branches at BIRMINGHAM, BRISTOL, CARDIFF, MANCHESTER, NEWCASTLE, SHEFFIELD

MARCONI HS SERIES

# High Frequency Transmitters

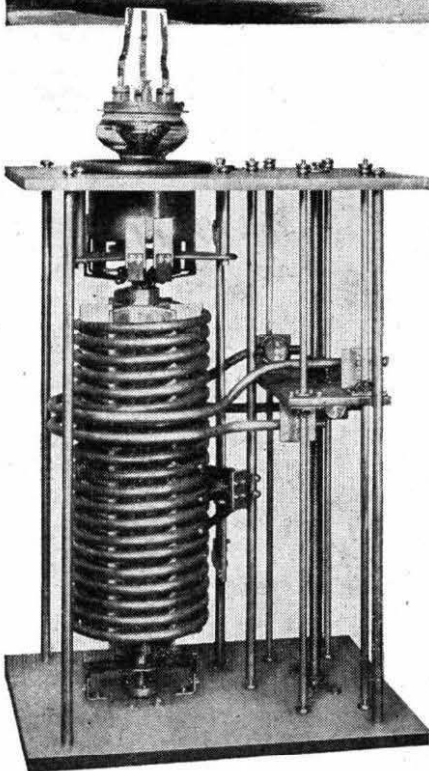
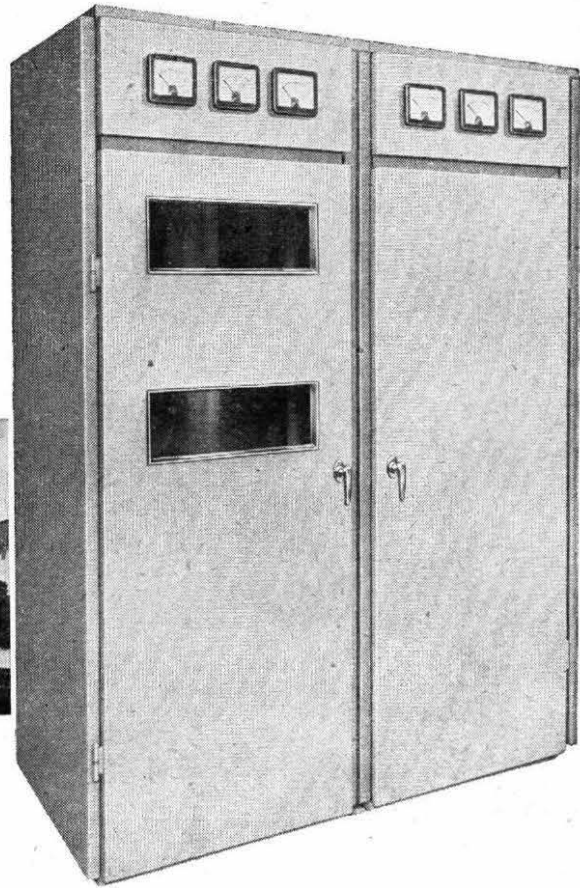
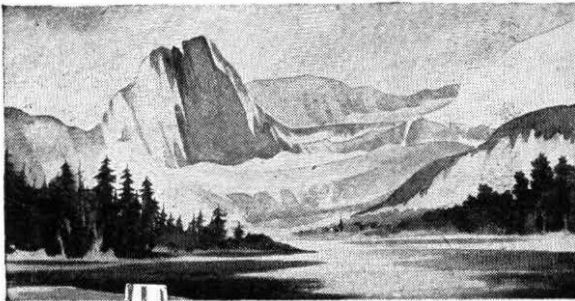

The HS.31, 41 and 51 Series of Transmitters have ratings of 2.5 Kw, 10 Kw and 30 Kw respectively ; all provide the following features : operation on any one of 6 spot frequencies or continuous tuning over the entire range, rapid frequency change between pre-set frequencies, easy and safe access for servicing ; RF feed back to reduce distortion ; air cooling throughout with dust filtering ; high overall efficiency.

Service flexibility is the keynote of these transmitters, all of which are designed as linear amplifiers ; ISB telephony, CW and frequency shift telegraphy, double sideband telephony, frequency shift duplex, can all be accommodated.

*An outstanding feature of the HS series of transmitters is the compact mechanism employed for anode tuning. The inductance is mounted integral with the valve anode assembly and is continuously variable.*

# MARCONI

COMPLETE COMMUNICATION SYSTEMS

*Surveyed, planned, installed, maintained*

MARCONI'S WIRELESS TELEGRAPH CO. LTD. • CHELMSFORD • ESSEX

# Air Sea Rescue ?

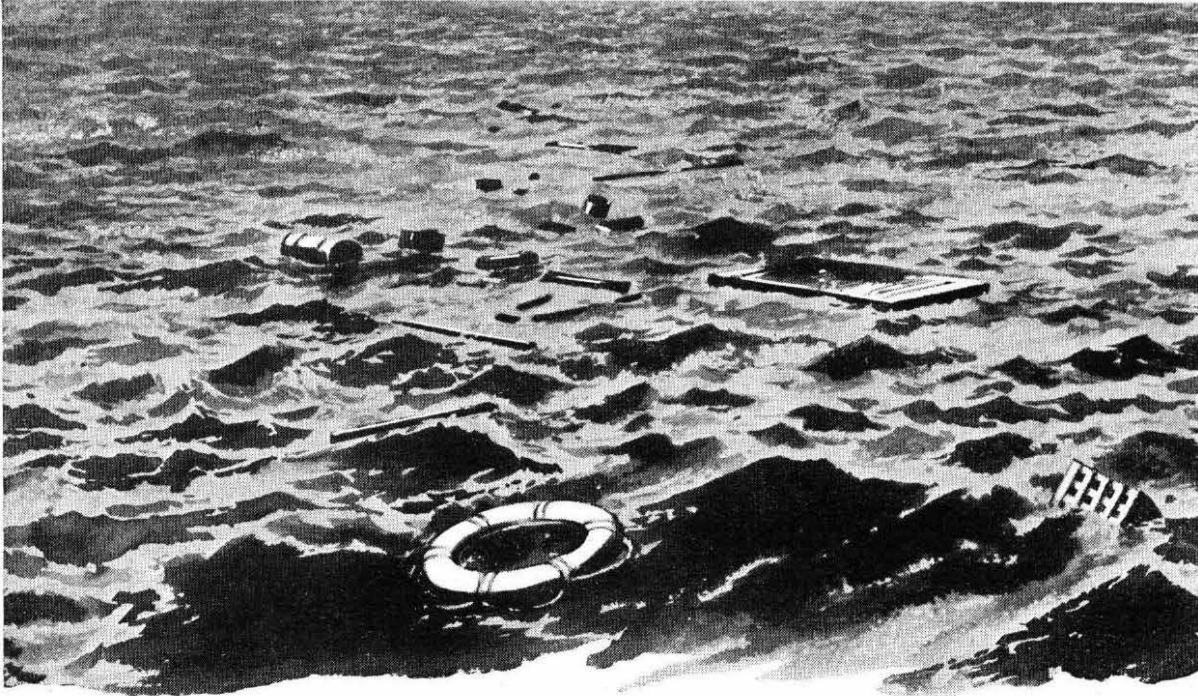

The "Princess Victoria" was lost just over a year ago and with her, 133 lives. This disaster occurred only 20 miles from land but search aircraft found the location too late because there was no ship-to-air communication. Further tragedies may well be avoided by ships being able to talk direct to each other and to aircraft. The RM.200 V.H.F. transmitter and receiver has been developed to meet this need.

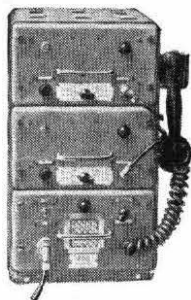

**TYPE RM 200** Multi-spot channel marine V.H.F. radio-telephone operating from A.C. Mains and/or Batteries. Amplitude Modulation.

**Range:** Ship-to-ship 25 miles; Ship-to-air over 100 miles.

Provides communication on the following INTERNATIONAL channels and 8 other channels.

121.5 Mc/s Aircraft Distress & Safety

156.3 Mc/s Marine Intership

156.6 Mc/s Marine Port Control

156.8 Mc/s Marine Safety & Calling

**Price £210 Delivery, 4 months**



---

## REES MACE MARINE LTD.

..... ONE OF THE



GROUP OF COMPANIES

# Marconi H.F. Field Intensity Meter TYPE TF 930



## Portable Equipment for f.m. and a.m. Field Strength Measurement

For use in the range 18 to 125 Mc/s, the Marconi H.F. Field Intensity Meter is portable, battery operated and complete with dipole aerial which can be telescoped for both tuning and transit. The design of the instrument permits measurement on both f.m. and a.m. transmissions during actual modulation.

The equipment is in the form of two carrying cases : one case houses the instrument proper, all operational controls being protected by a detachable lid ; the second case contains the collapsible aerial assembly.



### FIELD INTENSITY RANGE

40 kc/s Bandwidth: 10 to 100,000  $\mu$ V per metre at 18 Mc/s.

100 to 2,000,000  $\mu$ V per metre at 125 Mc/s.

150 kv/s Bandwidth: Approx. 1/4 sensitivity of 40 kc/s bandwidth.

### OUTPUT

Audio: Operates panel meter or phones.

Recorder: Operates any recorder of 5 mA f.s.d. and 560 ohms resistance, maximum values.

## MARCONI INSTRUMENTS

SIGNAL GENERATORS · VALVE VOLTMETERS · Q METERS · FREQUENCY STANDARDS  
BRIDGES · WAVEMETERS · WAVE ANALYSERS · BEAT FREQUENCY OSCILLATORS

MARCONI INSTRUMENTS LTD · ST. ALBANS · HERTS · Telephone: St. Albans 6161/7

Midland Office: 19 The Parade, Leamington Spa

Northern Office: 30 Albion Street, Kingston-upon-Hull

Export Office: Marconi House, Strand, W.C.2.



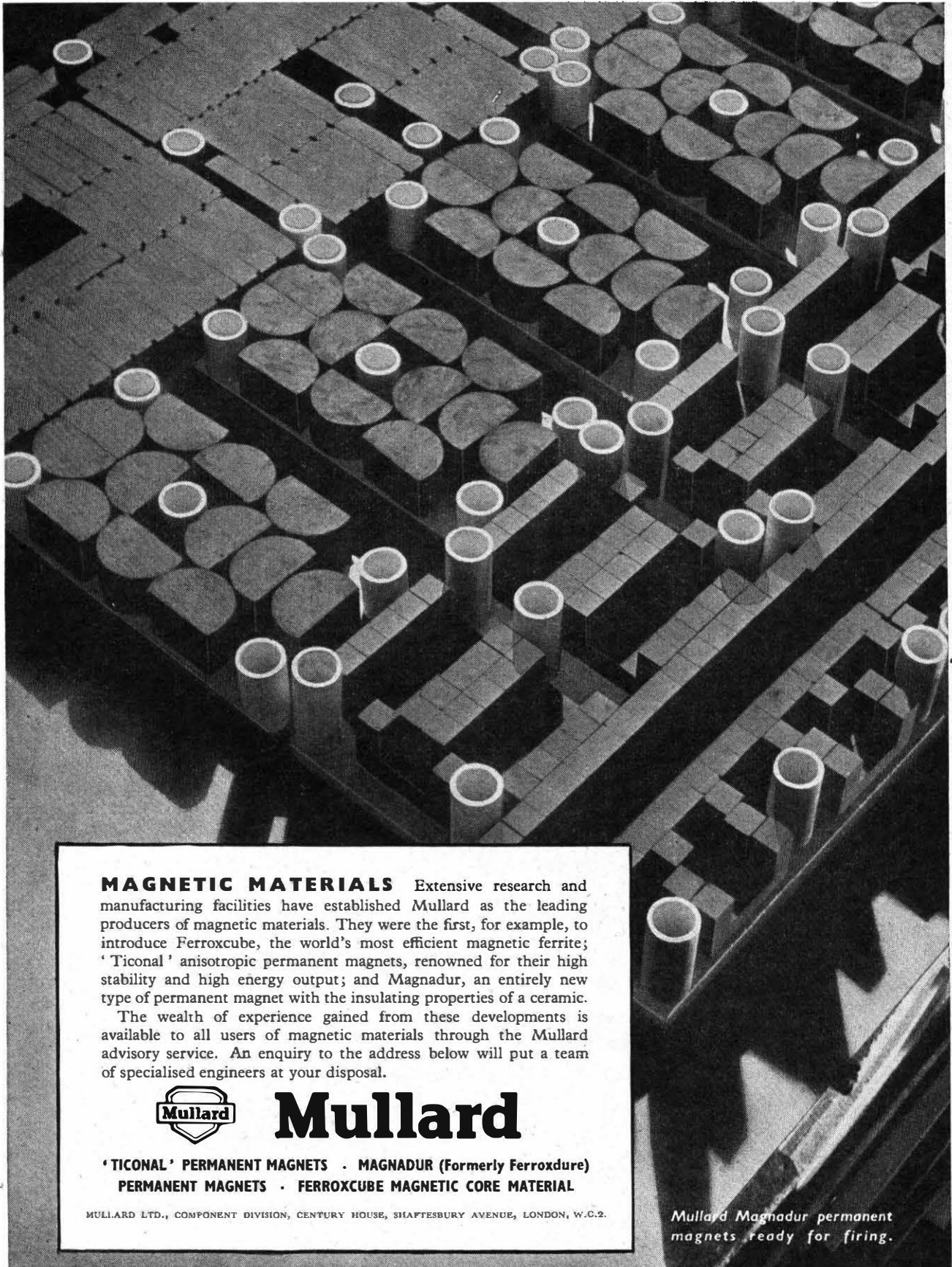

**MAGNETIC MATERIALS** Extensive research and manufacturing facilities have established Mullard as the leading producers of magnetic materials. They were the first, for example, to introduce Ferroxcube, the world's most efficient magnetic ferrite; 'Ticonal' anisotropic permanent magnets, renowned for their high stability and high energy output; and Magnadur, an entirely new type of permanent magnet with the insulating properties of a ceramic.

The wealth of experience gained from these developments is available to all users of magnetic materials through the Mullard advisory service. An enquiry to the address below will put a team of specialised engineers at your disposal.



# Mullard

'TICONAL' PERMANENT MAGNETS · MAGNADUR (Formerly Ferroxdure)  
PERMANENT MAGNETS · FERROXCUBE MAGNETIC CORE MATERIAL

MULLARD LTD., COMPONENT DIVISION, CENTURY HOUSE, SHAFFESBURY AVENUE, LONDON, W.C.2.

*Mullard Magnadur permanent magnets ready for firing.*

**ELECTRICAL MEASURING  
INSTRUMENTS  
OF THE HIGHER GRADES**

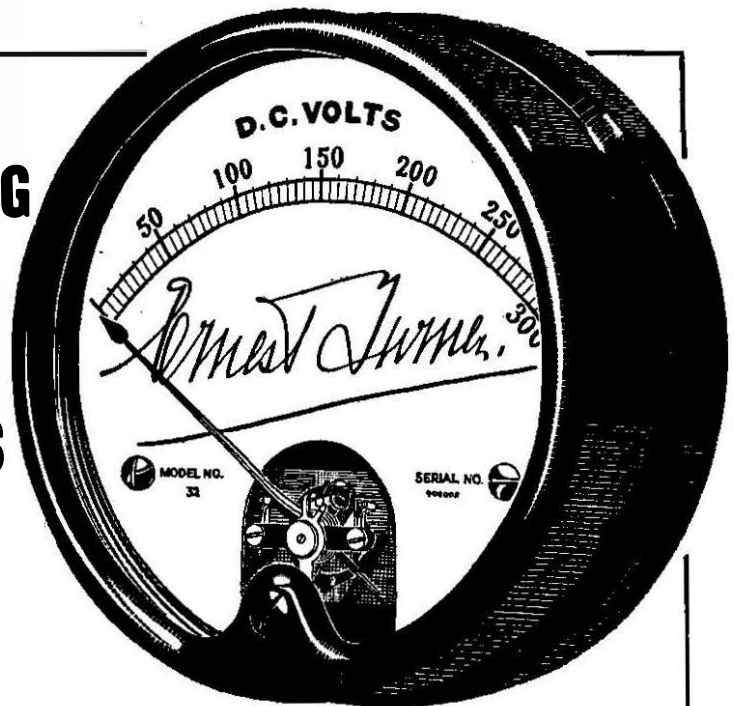

**ERNEST TURNER ELECTRICAL INSTRUMENTS LTD.**  
CHILTERN WORKS, TOTTERIDGE AVENUE, HIGH WYCOMBE, BUCKS.

Telephone : High Wycombe 1301/2

Telegrams : Gorgeous, High Wycombe

**FREQUENCY METERS**

- \* *New Design*
- \* *Compact*
- \* *Good Delivery*

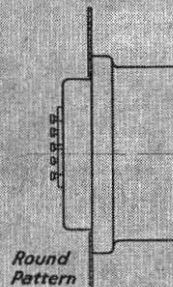
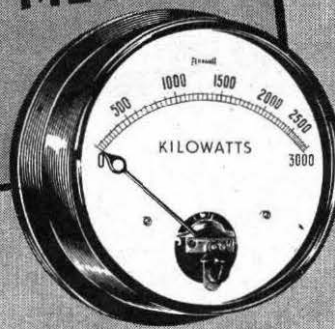

The illustration shows a 6" dial Deflectional Frequency Meter. Shallow pressed steel case. 4", 6" or 8" round or square dial, semi-projecting or flush mounting. Other recently designed Ferranti instruments include, ammeters, voltmeters, power factor meters and dynamometer wattmeters. All types are also available in hermetically sealed cases.

**FERRANTI** *Switchboard Instruments*

FERRANTI LTD · MOSTON · MANCHESTER

Head Office and Works, HOLLINWOOD, LANCs (London Office, KERN HOUSE, KINGSWAY W.C.2)

F1125E



*By Appointment to the Professional Engineer*

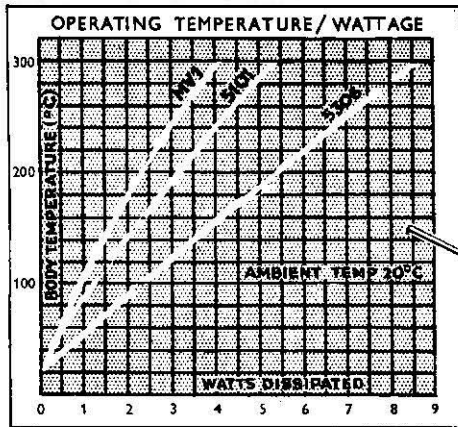

## MIDGET WIREWOUND VITREOUS RESISTORS

MINIATURE EQUIPMENTS  
DEMAND MIDGET RESISTORS

Dimensionally  
Painton **MIDGET** resistors  
offer the **MAXIMUM WATTAGE DISSIPATION**  
**MAXIMUM OHMIC RANGE**  
**MAXIMUM SAFETY FACTOR**

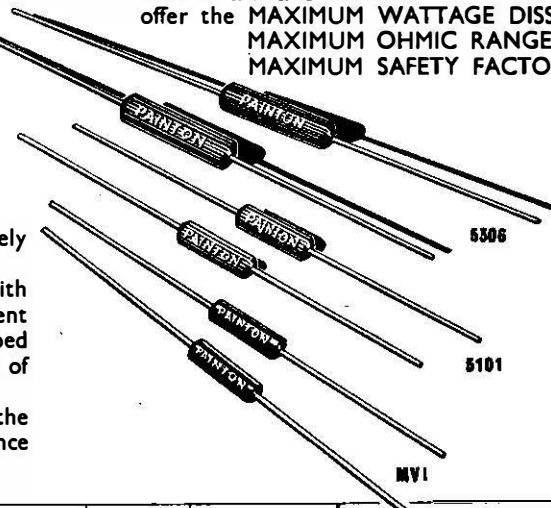

In the Heavy Duty **MIDGET** Range, the extremely high wattage dissipation is achieved by:  
(a) the use of a sintered alumina ceramic former, with thermal conductivity approximating steel (Patent 626128), in conjunction with a Painton glaze developed to match the thermal and mechanical properties of sintered alumina,  
(b) the exceptional strength and conductivity of the Painton "Intermediate Wire Process" of resistance termination (Patent 575297).

Range	Type	Resistance Range Ohms		Tol.	Rating Watts		Max. Working Temp.	Temperature Coefficient	DIMENSIONS			
		Min.	Max.		Normal 20 °C.	Tropical 70 °C.			Length	Diam.	Lead	
											Length	Material
Standard	MVI	1 10	9.99 4700	10% 5%	4	3	300 °C.	BELOW 100°— NEGLIGIBLE ABOVE 100°— 0.01%/°C.	15" 32	13" 64	1/4"	20 S.W.G.
Heavy Duty	5101	1 10	9.99 4700	10% 5%	5.5	4	350 °C.	BELOW 100°— NEGLIGIBLE ABOVE 100°— 0.01%/°C.	15" 32	13" 64	1/4"	Silver Clad Copper
Heavy Duty	5306	10	15000	5%	8.5	7	350 °C.	BELOW 200°— NEGLIGIBLE ABOVE 200°— 0.01%/°C.	13" 16	9" 32	1/2"	Wire

**PAINTON**  
*Northampton England*

**ATTENUATORS AND FADERS • STUD SWITCHES • FIXED AND ADJUSTABLE WIREWOUND RESISTORS  
WIREWOUND POTENTIOMETERS • MIDGET R.F. CHOKES • HIGH STABILITY CARBON RESISTORS • TERMINALS  
PLUGS AND SOCKETS • KNOBS, DIALS AND POINTERS • TOGGLE SWITCHES • PUSH BUTTON SWITCHES**

# SIEMENS

## 12 Channel CARRIER TELEPHONE EQUIPMENT Type CS 12/C

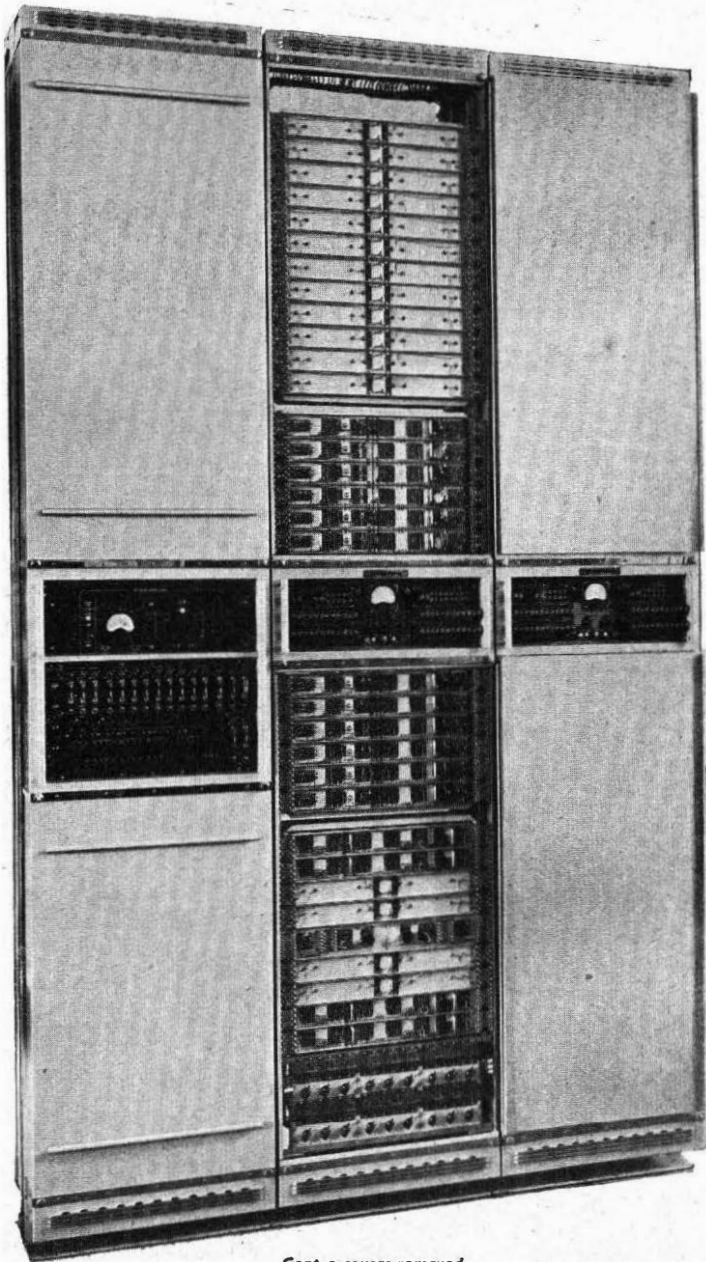

Centre covers removed

THE ILLUSTRATION SHOWS A TYPICAL SIEMENS CARRIER TELEPHONE TERMINAL EQUIPPED FOR 24 CHANNELS COMPLETE WITH CARRIER SUPPLY, LINE AMPLIFIERS AND FILTERS, RINGERS AND TERMINATIONS.

- Complying in all respects with C.C.I.F. recommendations for 12 channel carrier systems.
- Operated from A.C. Mains and suitable for connection to underground cable, overhead line or radio link systems.
- Incorporating the new Siemens method of mounting apparatus to give a compact equipment while providing accessibility and ease of maintenance.

**SIEMENS BROTHERS & CO., LIMITED**  
WOOLWICH • LONDON • S. E. 18.





## Another Strowger Exchange

Woerden is a "Sector" exchange and is one of the latest to be commissioned by the Netherlands Postal and Telecommunication Services as part of the nation-wide automatization plan. Woerden exchange serves a local network of eight "End" exchanges. In addition, the Woerden equipment incorporates facilities for the discrimination, routing, timing and zone metering of calls under the national dialling system. The basic selecting mechanism is the Type 32A Mark II selector which incorporates in its design all the facilities which many years operational experience have shown to be necessary, yet retains the simple straightforward step-by-step principle of operation characteristic of the Strowger system. To-day this selector offers the most suitable basis for automatic telephone systems of any size. Its simplicity, reliability and ease of maintenance are the factors of principal appeal to telephone administrations in all parts of the world.

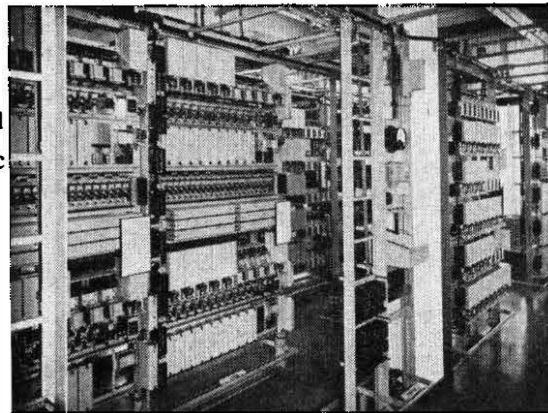

**AUTOMATIC TELEPHONE & ELECTRIC CO. LTD.,**

EXPORT DEPARTMENT: STROWGER HOUSE, ARUNDEL STREET, LONDON, W.C.2. TELEPHONE:  
TEMPLE BAR 9262 CABLEGRAMS: STROWGEREX LONDON. STROWGER WORKS, LIVERPOOL, ENGLAND.

AT7811-A104

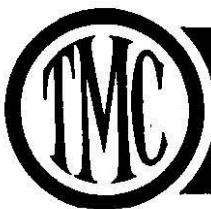
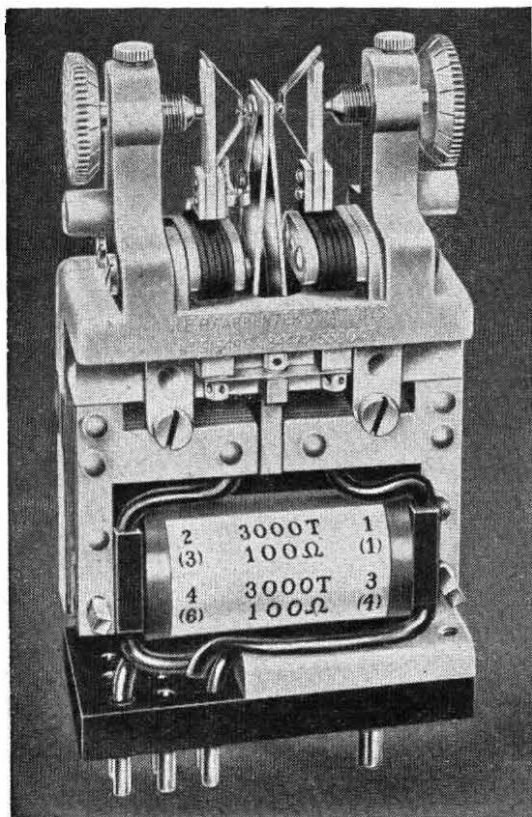

## CARPENTER POLARIZED RELAY TYPE 4

The chief characteristics of this relay are low transit time—high contact pressure—freedom from contact chatter and positional error—high sensitivity—stability—symmetrical action—and ease of adjustment.

On V.F. dialling systems its use facilitates the design of sensitive receiving equipment, and on trunk telephone circuits the relay's high sensitivity enables it to respond to D.C. dialled impulses received over unrepeaters trunk lines of up to 100 miles long.

It is particularly suitable as an impulse accepting relay when a minimum of signal distortion is imperative, and because of the excellent change-over action and absence of contact chatter the relay is unequalled for impulsing the selector magnets in teleprinter automatic switching systems.

The relay responds satisfactorily to frequencies up to 100 c/s, when the contact gap is adjusted to 0.004 in. nominal, without serious bias disturbance. It can be left connected to line whilst awaiting a clearing signal, there being little distortion of through signals since the total leak can be of the order of 10,000 ohms.

Dimensionally the relay is interchangeable with the "3000" type relay. Terminations can either be made by means of a 12-pin plug base as illustrated, or with soldering tags in place of the pins. Protection is given by a magnetic screen and a transparent cap which is removable for contact adjustments.

*Complete details supplied on request.*

*Manufactured by the Sole Licensees:—*

**TELEPHONE MANUFACTURING COMPANY LIMITED**

*Contractors to Governments of the British Commonwealth and other Nations*

**HOLLINGSWORTH WORKS · DULWICH · LONDON S.E.21 TEL: GIPSY HILL 2211 (10 LINES)**

# ZEVA

*Electric*

## SOLDERING TOOLS

for **SPEED, ECONOMY**  
and **BETTER WORK**



The news that this famous range of Soldering Irons and Crucibles is again available has been welcomed in numerous branches of industry everywhere. Zeva Tools are unquestionably without equal for efficiency, economy and trouble-free long life.

- ZEVA heating elements never need renewal. They last the life of the tool.
- ZEVA Irons can be left switched on all day without detriment to the tool.
- ZEVA current consumption for rated temperature is less than any other make of tool.
- ZEVA initial cost is the only cost.
- ZEVA Irons are guaranteed.

Write for complete  
Illustrated Catalogue:—

**THE AUTOMATIC COIL WINDER & ELECTRICAL EQUIPMENT CO., LTD.**  
Winder House, Douglas Street, London, S.W.1

Phone: VICtoria 3404-9

Z1/P2/ZWS

# Standard

## in 6 Continents

The **D.S.** RADIO POINT-TO-POINT

# TRANSMITTER

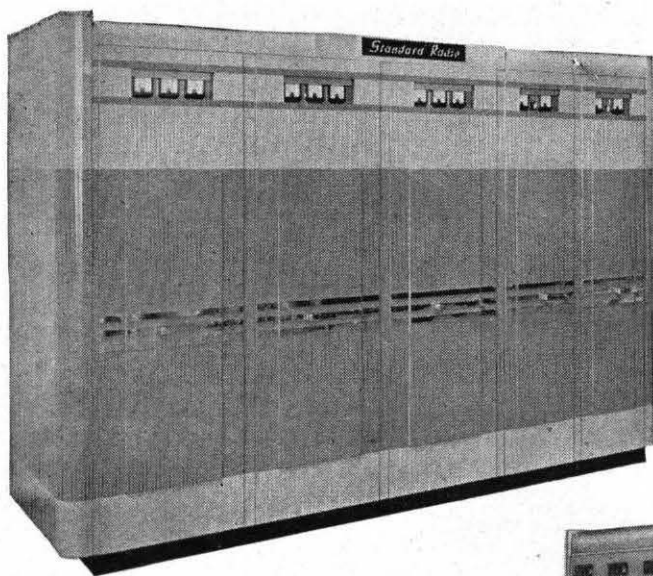

**More than 180 of these transmitters are in use throughout the World**

✱ Available for early delivery

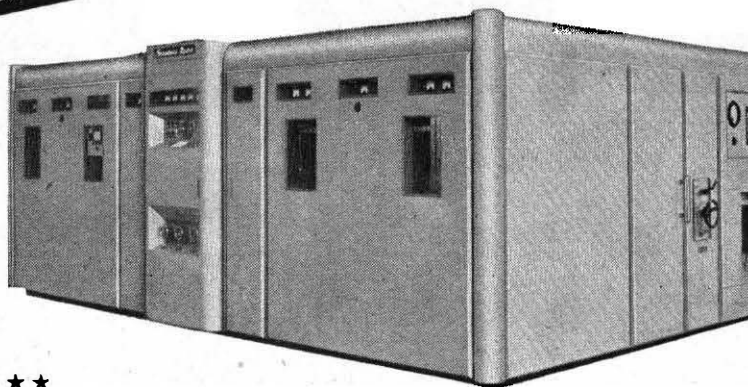

*P*owerful 40 kilowatt D.S.13's were used to transmit Her Majesty the Queen's Speech direct from Auckland, New Zealand, to the United Kingdom on Christmas Day, 1953.

D.S. series of transmitters ★★★★★★★★★★

★ <b>D.S.10</b>	★ <b>3/5 kW</b>	★ Double Sideband	★
★ <b>D.S.12</b>	★ <b>4 kW</b>	★ Independent or Single Sideband	★
★ <b>D.S.13</b>	★ <b>40 kW</b>	★ Independent or Single Sideband	★

★★★★★★★★★★★★★★★★★★★★

Write for Radio leaflets :  
Type **D.S.10** No. 179/8  
Type **D.S.12** No. 129/8  
Type **D.S.13** No. 130/8

# Standard Radi



## Standard Telephones and Cables Limited

Registered Office : Connaught House, 63 Aldwych, London, W.C.2.  
**RADIO DIVISION · OAKLEIGH ROAD · NEW SOUTHGATE · LONDON, I**

# Two **NEW** miniature Relays

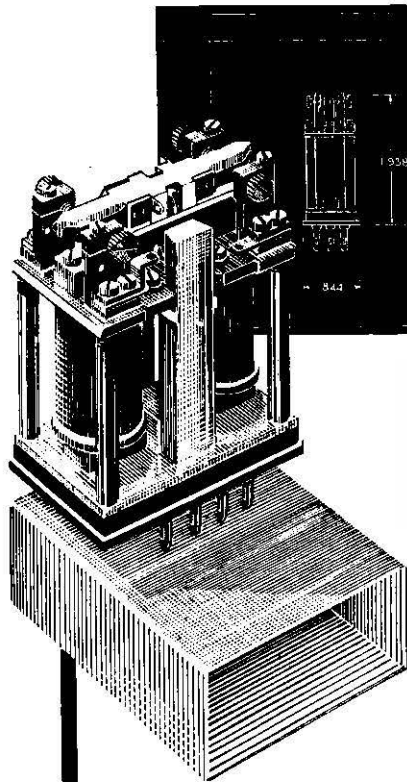

## ① Polarised Relay

- ★ High magnetic sensitivity
- ★ Large winding space • High copper efficiency
- ★ Symmetrically balanced movement
- ★ High Thermal and Shock stability
- ★ Low susceptibility to magnetic interference

## ② Type 1A Relay

- ★ Exceptionally high sensitivity
- ★ Balanced movement
- ★ High Thermal and Shock stability
- ★ Hermetically sealed

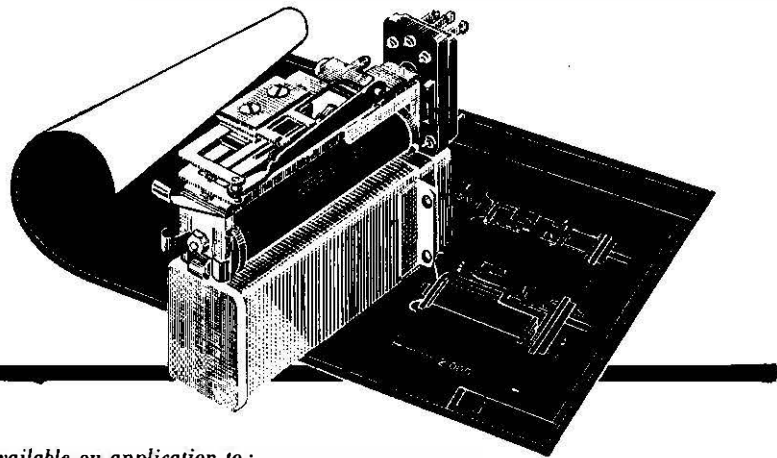

Catalogue available on application to: —

Head Office: 22 LINCOLN'S INN FIELDS LONDON WC2 Tel: HOL. 6936

E.17



# 1 kW Channelised Transmitter

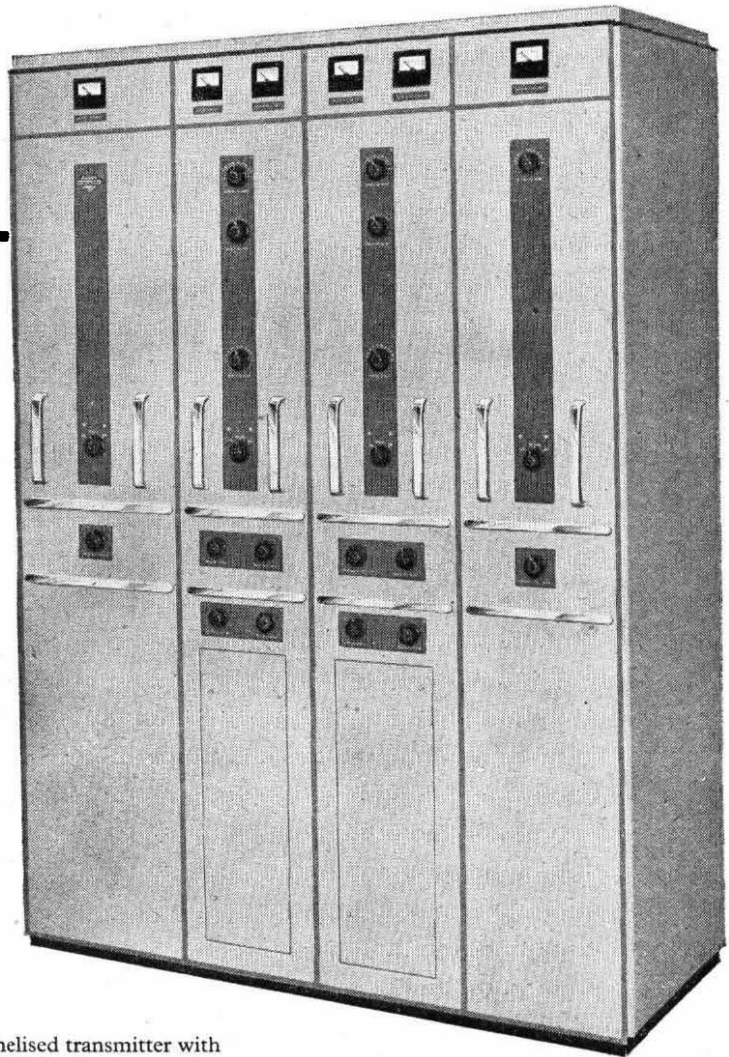

**T**HE GFT.560 is a 1kW channelised transmitter with a frequency range of 1.5—30 Mc/s. It consists of three basic cabinets—r.f. unit, modulator unit, and power supply unit—combinations of which can be used to provide multi-frequency working as well as a number of different types of emission. The wave change facilities of the transmitter are both rapid and reliable—a valuable asset when the operating frequency is changed many times each day.

The GFT.560 is fully tropicalised, and its unit construction facilitates future expansion of the initial installation, should the need arise.

For use in conjunction with the GFT.560 there are ancillary units that enable the transmitter to be remotely controlled over a two wire telephone circuit: operational adjustments are dialled to the transmitter.

The versatility and reliability of this new Mullard transmitter make it particularly suitable for h.f. en-route, ground-to-air services and point-to-point communication networks. A team of Mullard communication engineer is available to advise on the use of the GFT.560 in such applications. They will also assist in planning complete communication systems, if required.

#### ABRIDGED DATA

*Frequency Range 1.5—30 Mc/s*  
*Frequency Stability To Atlantic City, 1947, standards*  
**Power Output 1 kW**  
*Types of Emission c.w., m.c.w., telephony, frequency shift, single and independent sideband, (A1, A2, A3, F1, A3a and A3b)*  
**Output Impedance 600 ohms balanced twin feeder**  
**Power Supply 400V, 50-60 c/s. 3-phase**

# Mullard



**SPECIALISED ELECTRONIC EQUIPMENT**

MULLARD LTD · EQUIPMENT DIVISION · CENTURY HOUSE · SHAFTESBURY AVENUE · WC2 (M1434)

# POWER *behind the lines*

TUNGSTONE PLANTÉ CELLS are being regularly supplied to the British Post Office and Post and Telegraph Departments in many countries overseas. They conform fully to G.P.O. Standard specifications.

#### OPEN TYPE CELLS

Similar to the illustration here, these are available in glass and/or lead lined wooden boxes in capacities from 100 a.h. to 5000 a.h.

#### REPLATALS

We are in a position to supply plates for the replating of existing Planté Batteries.

#### ENCLOSED TYPE CELLS

As illustrated below, these are in moulded glass boxes with sealed-in lid. Capacity range from 10 a.h. to 200 a.h.

#### PORTABLE TYPE BATTERIES

A range of portable type Batteries is in regular production, made to G.P.O. specifications, for ancillary duties.

*Overseas customers are invited to cable or write their enquiries for batteries or parts. Visitors to London are welcome at our offices. (Just off Fleet Street.)*

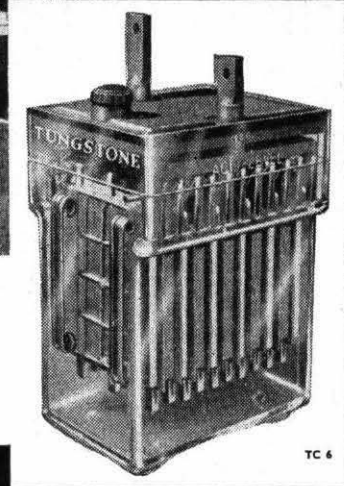
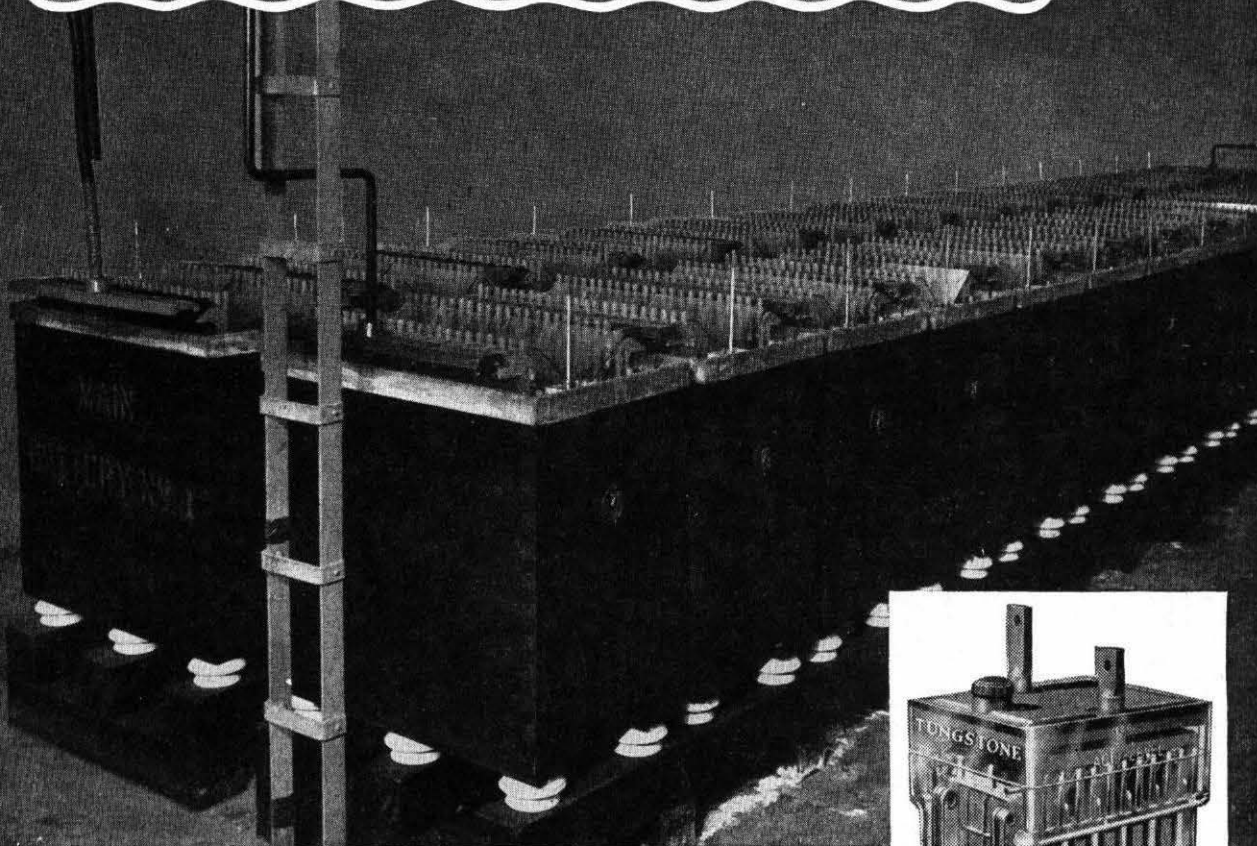

## TUNGSTONE *Batteries*

For further particulars write : TUNGSTONE PRODUCTS LIMITED,  
10 SALISBURY SQUARE, LONDON, E.C.4, ENGLAND. Cables: "Dilutum" London.

TC 6

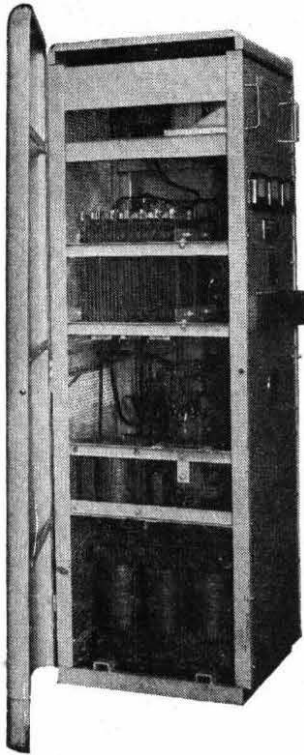

# THE TRANSBOOSTER

The Transbooster is an improved method of voltage control, the equipments being produced in either static or mobile housings to suit varying requirements. A range of outputs is available and the illustration here shows a 3 kW model giving an output of 60 amperes at 50 volts nominal, smoothed for telephone exchange use. It is designed to hold D.C. output voltage within limits of  $\pm 1\%$  from 1/20th up to full load and is independent of mains voltage variations of  $-10\%$  to  $+6\%$  and frequency variations from 48 to 52 c/s. The applications of this equipment are extensive, and full details of



**CONSTANT POTENTIAL RECTIFIERS**

*can be obtained on request to. . .*

Dept. P.O.E.E.J. 4

**WESTINGHOUSE BRAKE & SIGNAL CO. LTD, 82 YORK WAY, KING'S CROSS, LONDON, N.1**

SULLIVAN & GRIFFITHS

## DIRECT READING VARIABLE CONDENSERS

WITH NOVEL AIR CAPACITANCE  
DECADE RANGE EXTENSION

This air dielectric condenser comprises a decade of air capacitance and a continuously variable air condenser thus giving a scale accuracy ten times that of an ordinary variable condenser of the same range.

Thus a decade of capacitance is provided—permanent in value and entirely free from loss, the only loss present in the complete combination of decade and variable condenser being that due to the solid insulating material which is ordinarily employed in the construction of the latter.

The variable condenser has a range of  $100\mu\text{F}$  which is extended to  $1100\mu\text{F}$  by ten increments of  $100\mu\text{F}$ , all adjusted with accuracy so that the decade is absolutely direct reading in  $\mu\text{F}$ , no corrections or calibration being necessary.

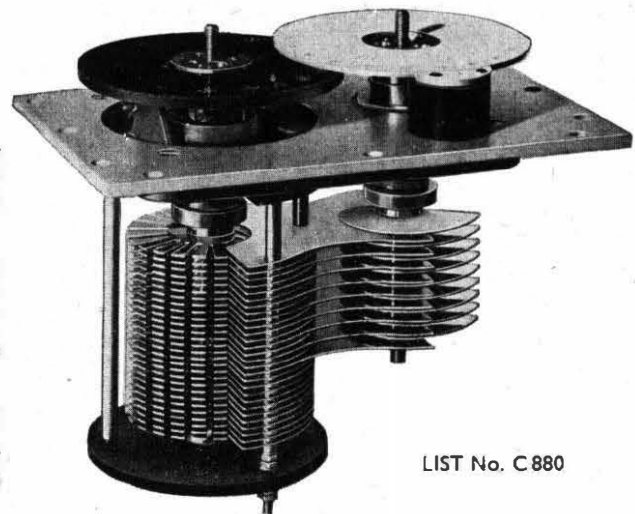

LIST No. C 880

## Electrical Standards for Research and Industry

Testing and Measuring Apparatus  
for Communication Engineering

**H. W. SULLIVAN, LTD., LONDON, S.E. 15.**



# CONVERTER

MODEL 2206



FOR CONVERSION OF 5-UNIT  
PERFORATED TAPE TO MORSE  
CODE PERFORATED TAPE



WORKING SPEED:  
650 CHARACTERS PER MINUTE



ALL POSSIBLE CHARACTERS  
IN THE 5-UNIT CODE CAN BE  
CONVERTED

*Converter model 2201 for conversion in the opposite direction,  
i.e. from Morse to 5-unit code, will be ready shortly*

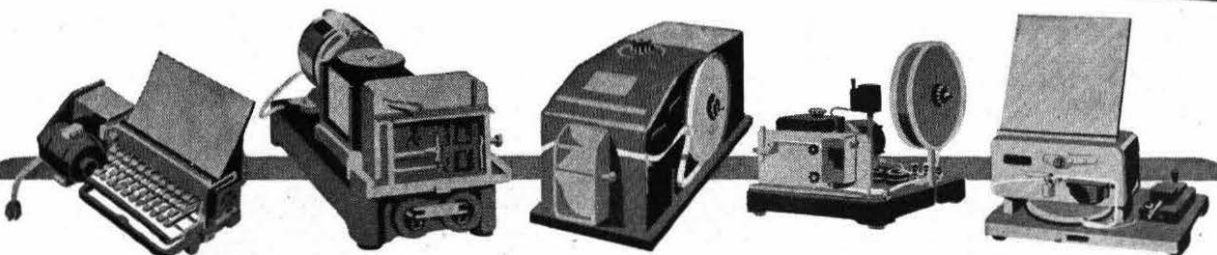

## GREAT NORTHERN TELEGRAPH WORKS

DIVISION OF THE GREAT NORTHERN TELEGRAPH CO. LTD.

4, SYDHAVNS PLADS  
COPENHAGEN SV, DENMARK

LONDON OFFICE: 5, ST. HELEN'S PLACE  
LONDON E. C. 3.



# **SKILLMANS** specialise in

**CARRIER CHANNELS** on

**OLD V.F. CABLES**

\* We have supplied well over a million pounds worth of carrier equipment working on a 2 wire H.F. path, of which more than half is on old-type Voice Frequency cables that have been deloaded, including considerable quantities of 20 *lb. city cable*, of decidedly poor quality.

\* We give overall performance guarantees on such jobs. In one case we took a contract of over £500,000, taking complete responsibility for a cable which was well outside specified limits and, by designing special amplifiers and neutralising devices, succeeded in meeting entirely requirements which were much more stringent than C.C.I.F. limits.

\* In general we can undertake to obtain more than double the existing channels from an old V.F. cable and, frequently, 3 or 4 times as many.

\* We carry out installation and field testing and can provide expert supervision for deloading, and (where required) rebalancing and neutralisation.

*ALL OUR EQUIPMENT MEETS C.C.I.F. REQUIREMENTS*

**T. S. SKILLMAN & CO. LTD.,** Grove Park, Colindale, London, N.W.9

**T. S. SKILLMAN & CO. PTY. LTD.,** Cammeray, Sydney, N.S.W.

SKILLMAN CARRIER EQUIPMENT HAS BEEN SUPPLIED TO ENGLAND FOR OTHER THAN C.P.O. APPLICATIONS, TO AUSTRALIA, NEW ZEALAND, BELGIUM AND EGYPT, AND ENQUIRIES ARE INVITED FOR REPRESENTATIVES ELSEWHERE

for every type of coil

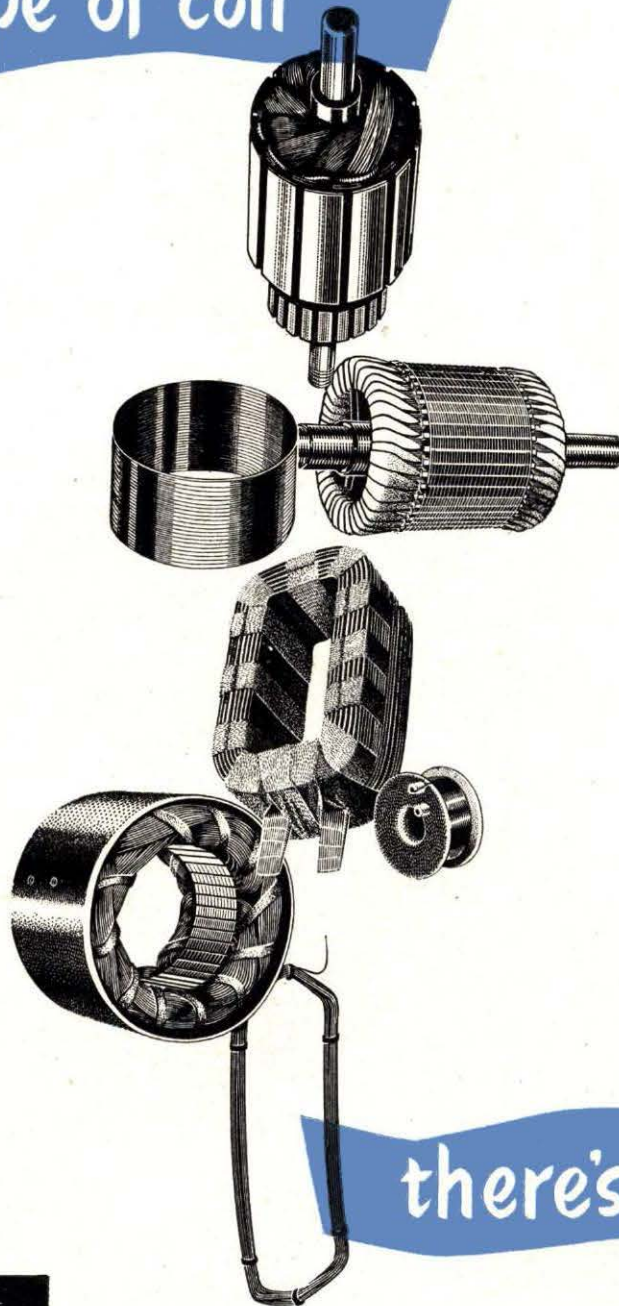

there's a

**BICC**

**WINDING WIRE**

**USE OUR TECHNICAL ADVISORY SERVICE**

If you are faced with a winding problem please ask for assistance; BICC technicians are always willing to give you the benefit of their experience. For most winding wire jobs the Publications listed will provide the data you require. They are available on request.

- No. 266 Insulated Winding Wires and Strips
- No. 296 "Bicaloc" Winding Wires (Self Bonding)
- No. 303 Enamelled Oil Base Winding Wires
- No. 322 "Bicalex" Winding Wires (Synthetic Enamel)
- No. 328 "Fifty-Three" Enamelled Winding Wires

**BRITISH INSULATED CALLENDER'S CABLES LIMITED**

xxi



**21 BLOOMSBURY STREET, LONDON, W.C.1**

**This is King's Pond**— and its waters almost lap the bricks of the Alton Battery Works' south-west wall. It is part of the Company's property—a 5-acre asset in real estate. And a symbol of assets in wider terms than accountancy covers. Alton is a country town—with a full, rounded, contented life of its own. A town where people have not yet changed to personnel. A town where families take root—and son follows father up to the Battery Works. A place where a man's proper pride in himself and his folk and the life he leads is reflected in doing things just that all-important bit better than 'up-to-specification.' And Alton batteries are made by Alton men

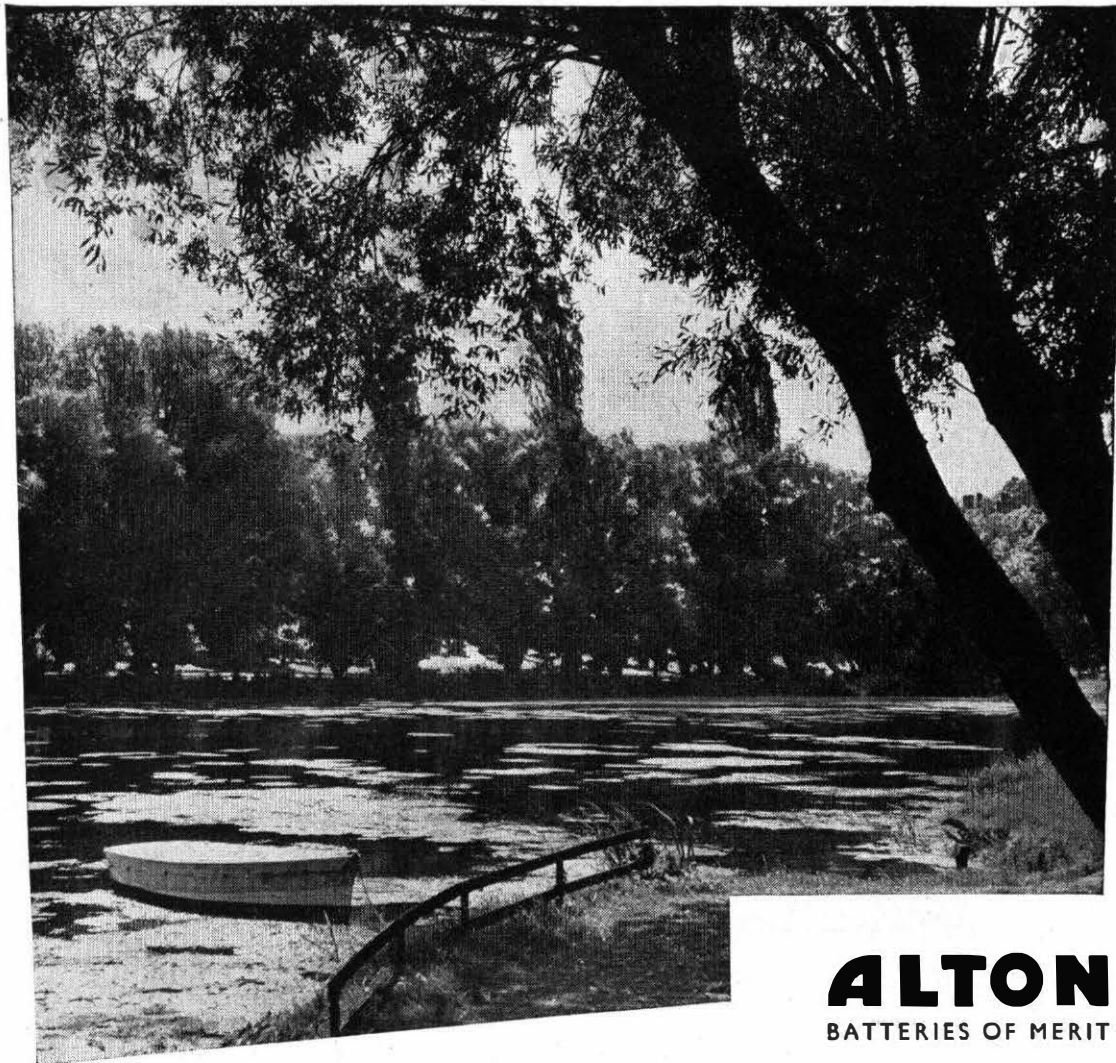

**ALTON**  
BATTERIES OF MERIT

Alton stationary batteries: 10 to 15,000 Ah. Also in regular production, renewal plates for all makes of battery, British and Continental.

A24A

The Alton Battery Company Limited · Alton · Hants · Telephone: Alton 2267 and 2268 Telegrams: Battery, Alton

# SKILLMANS

## TAPE CONTROLLED MEASURING GEAR

*for*

## COMPLETE TRANSMISSION TESTING & FAULT LOCATION

*on*

## LONG LINE EQUIPMENT

## (V.F. & CARRIER)

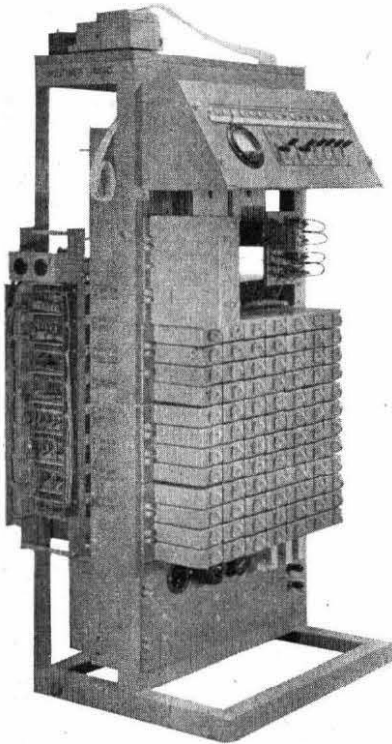

We are pleased to offer transmission testing equipment which will release skilled technicians from all routine testing work and most fault location work in Repeater and Terminal, V.F. and Carrier Stations.

- \* Sensational savings in maintenance costs.
- \* Can be applied to any type of equipment and introduced speedily into any existing station.
- \* Operating procedure is simple. The appropriate tape is placed in the machine which then functions—if necessary for many thousands of different tests for some hours—and draws attention to itself only when it is finished or when it has located a fault.
- \* At the cost only of paper tapes, far more elaborate testing routines, and whole ranges of variation in limits can be introduced, such as would be quite outside the bounds of possibility by manual methods.
- \* One tape controls the tests and test limits to be applied; a second controls the access to different circuits or channels. Different sets of tapes are prepared to cover daily tests on all circuits; periodical tests on selected groups of circuits; and detailed tests for fault location on particular pieces of equipment. The equipment informs the maintenance man where and what the fault is.
- \* Other tapes provide for bench tests of individual units.
- \* Overall tests between stations are included, with provision for control of the far end from the originating end by normal telegraph channel.
- \* Access equipment is extremely simple and, due to very adequate shielding, can be wired in to existing equipment without complication.
- \* Routine measurements recorded automatically when required. The record is on paper, and directly readable and ready for filing.
- \* Tests are repeated indefinitely when required to locate intermittent faults and provision is made for combining with vibration testing.
- \* Dialling and other signalling tests on all existing types of signalling gear fully catered for.

We now have considerable experience in designing such equipment and in the programming by tape. We will be pleased to arrange demonstrations in London and Sydney and to provide expert staff to advise in the application to existing installations.

**T. S. SKILLMAN & CO. LTD.,**  
Grove Park, Colindale, London, N.W.9

**T. S. SKILLMAN & CO. PTY. LTD.,**  
Camberay, Sydney, N.S.W.

SKILLMAN EQUIPMENT HAS BEEN SUPPLIED TO ENGLAND FOR OTHER THAN G.P.O. APPLICATIONS, TO AUSTRALIA, NEW ZEALAND, BELGIUM AND EGYPT, AND ENQUIRIES ARE INVITED FOR REPRESENTATIVES ELSEWHERE



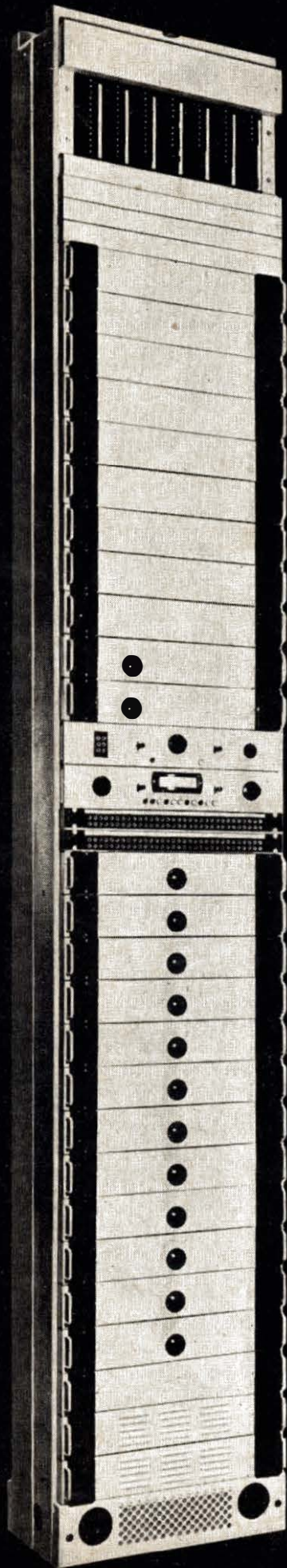

**DESIGNED**

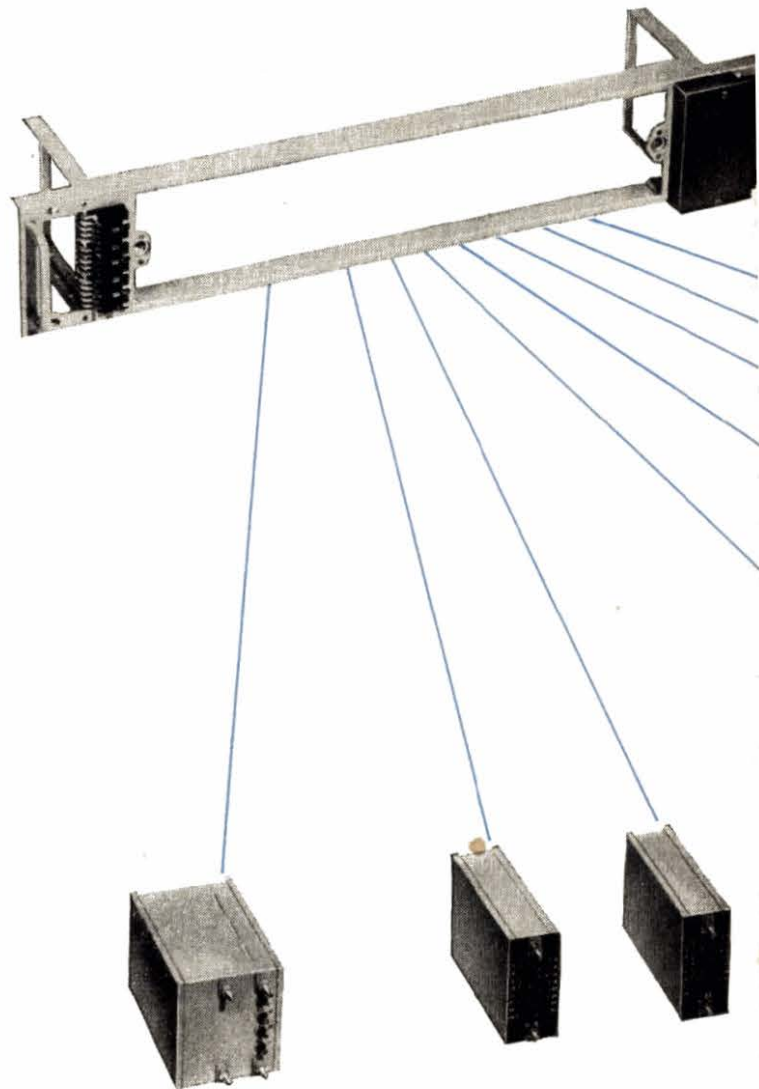

**F O R**

*Continuous*

**S E R V I C E**

ATE/TMC transmission equipment is designed to offer an operating administration the maximum facility in installation and in subsequent maintenance routines. A bayside can be unpacked, carried, erected and equipped by one man if necessary. Panel frames, fitted with quickly detachable functional units, are of the "jack-in" type, an arrangement which ensures the most rapid form of servicing yet devised. Further information is contained in the brochure "Unit Construction Practice" a copy of which will be forwarded on request.

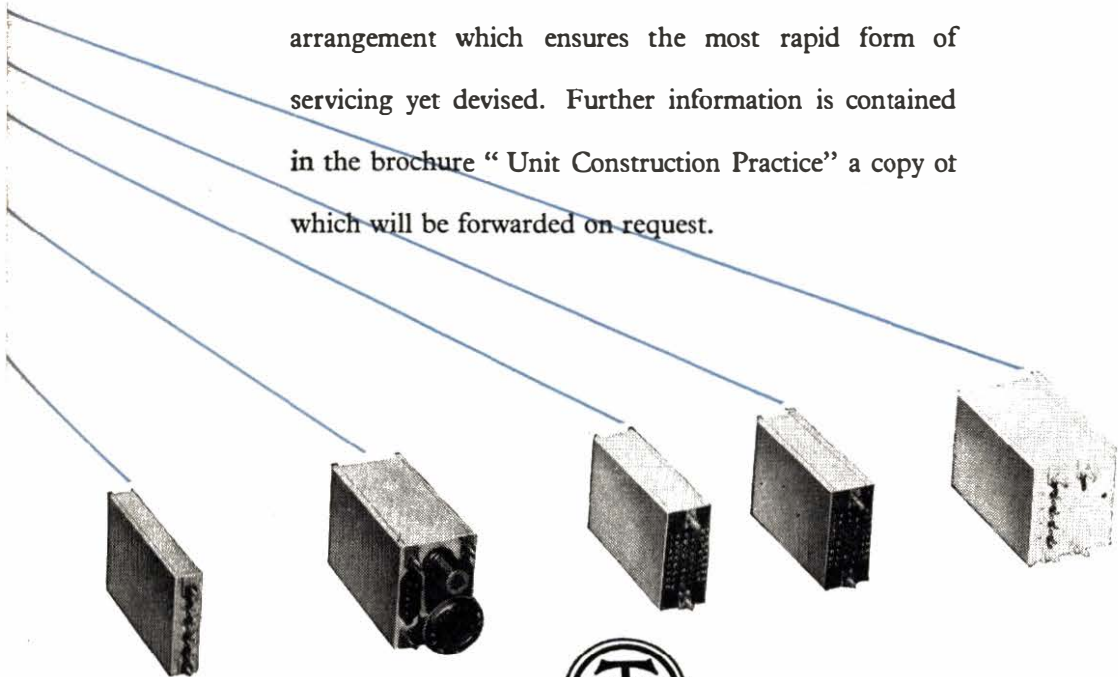

**AUTOMATIC TELEPHONE & ELECTRIC CO. LTD.**

Radio and Transmission Division, Strowger House, Arundel Street, London, W.C.2. Telephone: TEMple Bar 9262. Cables: Strowgerex London. Manufacturers:—AUTOMATIC TELEPHONE & ELECTRIC CO. LTD., Liverpool & London. TELEPHONE MANUFACTURING CO. LTD., St. Mary Cray, Kent.



# FIRE, AMBULANCE

MORE THAN  
TWO-THIRDS  
OF ALL THE  
V.H.F. RADIO  
TELEPHONE  
EQUIPMENT  
IN BRITAIN  
IS SUPPLIED  
BY PYE LTD.

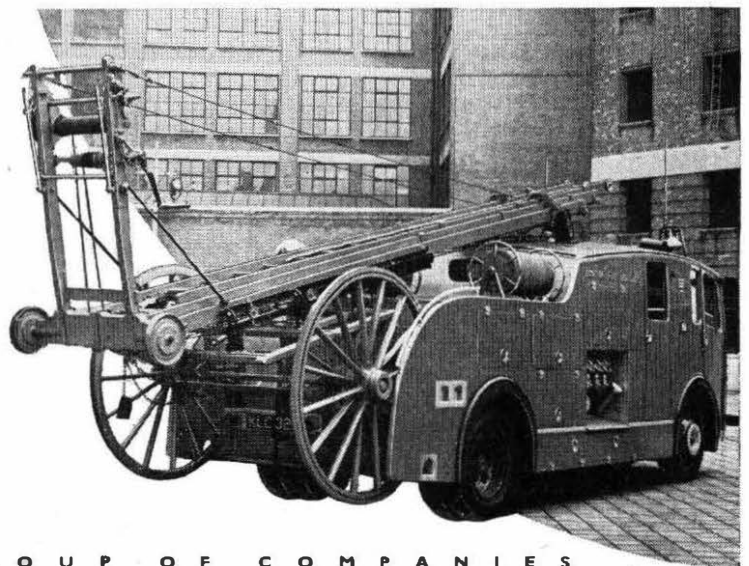
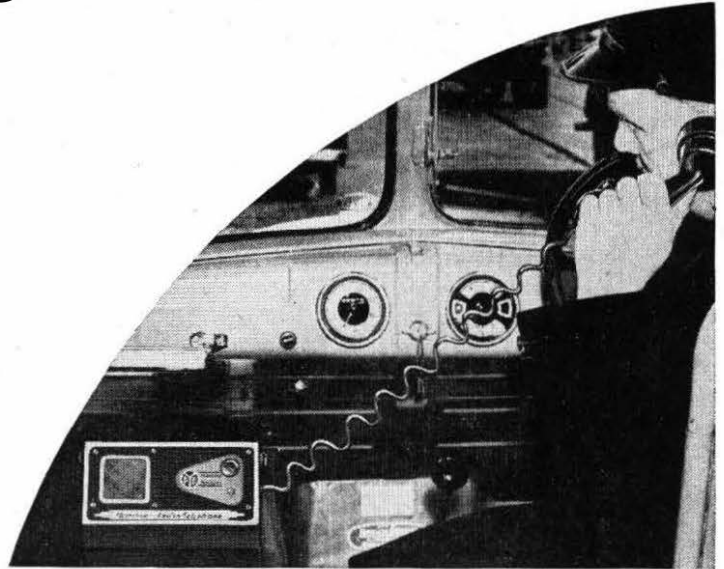

T H E P Y E G R O U P O F C O M P A N I E S

# AND POLICE SCHEMES



Pye V.H.F. radio telephone equipment provides immediate contact in circumstances which render normal telephone communication impossible. This makes it of special interest to local authorities, not only for their police and ambulance services, where speed and manoeuvrability are essential, but also for their fire services to give the controlling officer ready contact with all strategic points of an incident.

On data derived from installations already in use in fifty-four countries, it has been estimated **that three vehicles fitted with this apparatus can do the work of four without it.** In the case of police and ambulance services, it releases vehicles throughout the day for routine running and allows urgent calls to be rapidly dealt with by the most conveniently placed ambulance or police car. The equipment is designed to operate with the maximum economy consistent with the best service over the area covered—giving low mains consumption at the fixed station and the minimum demand on the mobile reporter battery.



# Communication

*Standard Systems in Service*

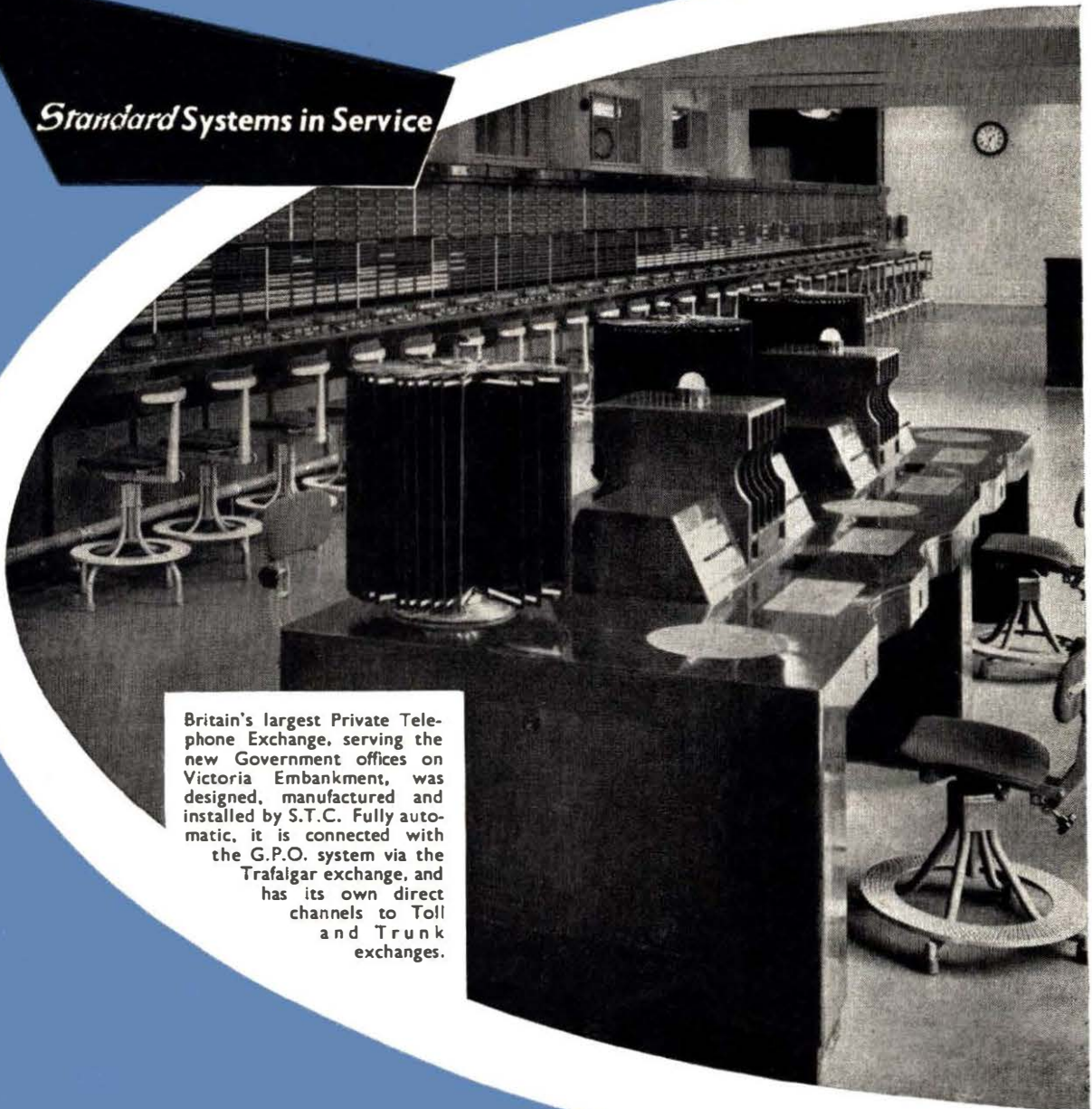

Britain's largest Private Telephone Exchange, serving the new Government offices on Victoria Embankment, was designed, manufactured and installed by S.T.C. Fully automatic, it is connected with the G.P.O. system via the Trafalgar exchange, and has its own direct channels to Toll and Trunk exchanges.



**Standard Telephones**

(TELECOMMUNICATION)

**Connaught House, Aldwych,**

Cairo

Dublin

Johannesburg

# and Control

*Standard systems include:—*

Standard's wide resources, their long experience in the design and manufacture of systems and equipment for telecommunications and control, have enabled them to produce an extensive range of apparatus for use in all parts of the world.

These resources and experience are at your service, either for the systems listed or for their development to meet specific needs, as well as for the supply of products including:—

SenTerCel Selenium Rectifiers  
Power Factor Correction  
Capacitors  
Power Cable  
Thermionic Valves  
Quartz crystals  
Magnetic alloys

Telephone  
Telegraph  
Radio Broadcasting  
Radio Communication  
Radio Navigation  
Sound Reproduction  
Remote Control  
Remote Indication  
Telemetry  
Railway Communication  
Railway Control  
Communication Cable  
Airfield Lighting Control  
Street Lighting Control  
Fire Alarm  
Totalisator  
Public Indicator  
Signalling (Office and Factory)

*and Cables Limited*

ENGINEERS)  
London, W.C.2, England

Karachi • New Delhi • Salisbury



**NEW**

**for an  
1889  
principle**

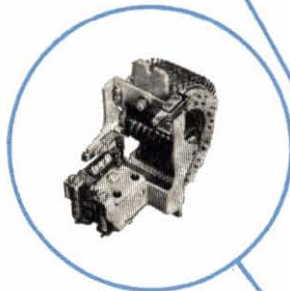
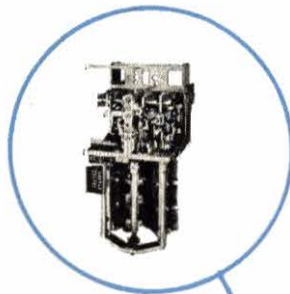

*G.E.C. Selector SE 50*

*G.E.C. Uniselector*

*G.E.C. Trigger Dial*



# STANDARDS

The employment of the Strowger principle of operation for more than two-thirds of the world's automatic telephones testifies to the inherent simplicity of step-by-step selection on a decimal basis with selectors stepping directly to dialled impulses.

Without departing from this logical principle, the G.E.C. has introduced apparatus that increases still further the reliability of the Strowger system whilst at the same time simplifying and reducing maintenance attention. The two-motion selector, the uniselector and the dial have all been re-designed after several years of research and development, and have already been adopted by many Administrations as the new standards for the 1889 principle.

A dark, stylized speech bubble or callout shape pointing downwards, containing the letters 'G.E.C.' in a white, elegant, cursive font.

G.E.C.



# 3 New Components

FOR THE ELECTRONICS INDUSTRY

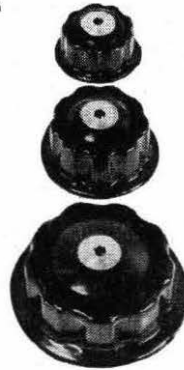
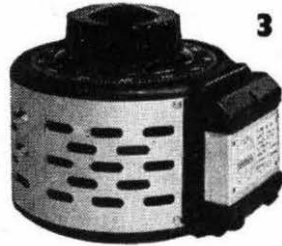
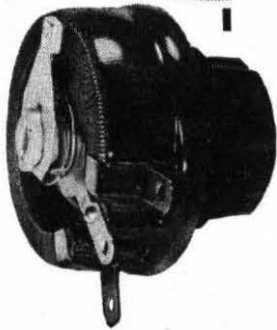

**1** **Bercostats.** A new range of power rheostats for industrial electronics. 5 sizes from 25 to 150 watts. All ceramic construction. Windings embedded in vitreous enamel giving great mechanical strength. Finishes comply with RCS.1000. Available in open, protected and ganged models.

**2** A range of 3 moulded knobs with collet fitting (Patent applied for) ensuring positive grip of circular shafts. Quickly and easily fixed and removed. Interchangeable collets for  $\frac{1}{8}$ ",  $\frac{1}{4}$ " and  $\frac{3}{8}$ " shafts.

**3** **Berco Rotary Regavolt Variable Transformers.** Two additions to the range of well known "Regavolt" regulating transformers, but of rotary type, for 200/250 volt supplies, ratings 0.8 and 2 amps respectively. Compact, smaller than any other transformer of comparable rating. Suitable for panel mounting.

\* See these and our wide range of high quality electronic components including: Hermetically sealed potentiometer, Fully Type Approved to Class H.I. of RCS. 121. Vitreous enamelled resistors, also Type Approved to Class H.I. of RCS.111.

THE BRITISH ELECTRIC RESISTANCE COMPANY LIMITED

QUEENSWAY, PONDERS END, MIDDLESEX. TEL: HOWARD 1492. 'GRAMS': "VITROHM, ENFIELD"

**BERCO**

BR 1091—AH

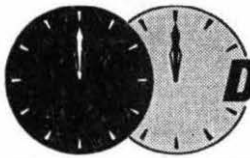

**DESIGNED FOR 24 HOURS PER DAY OPERATION**

## BATTERY DRIVEN CARRIER CURRENT GENERATORS FOR VOICE FREQUENCY TELEGRAPH TRANSMISSION . . . .

These generators are the result of many years experience in this field. They are made in three forms for 18, 24 or 27 channel transmission systems. Frequency ranges 420 to 2460 c.p.s., 420 to 3180 or 300 to 3420 c.p.s. in 120 c.p.s. steps.

Speed and frequency accuracy  $\pm 0.12\%$  for long periods without maintenance. Input 20 to 28 volt d.c. or 150 to 184 volts d.c.

Comprehensive details from the Manufacturers . . .

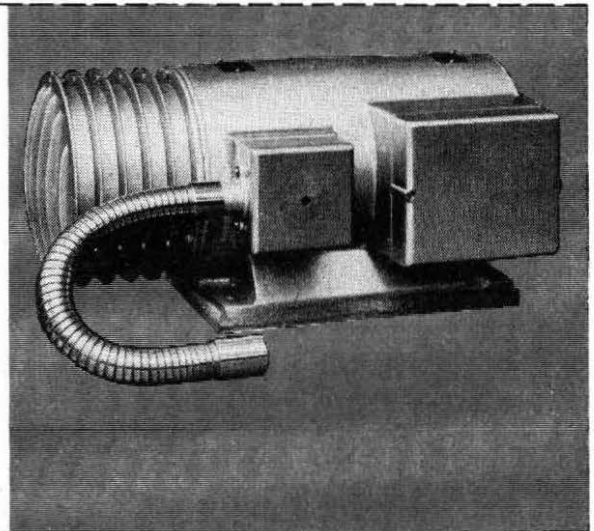

**WALTER JONES**  
& Company (Engineers) Limited

NEWLANDS PARK • SYDENHAM  
LONDON • S.E.26 • SYDenham 6264

Put your name on our mailing list  
for

# TECHNIQUE

A JOURNAL OF INSTRUMENT ENGINEERING

NAME .....

MAILING ADDRESS .....

.....

COMPANY .....

POSITION .....

120

MUIRHEAD & CO. LTD · BECKENHAM · KENT · ENGLAND  
MAKERS OF HIGH GRADE PRECISION ELECTRICAL INSTRUMENTS

## ANACOS

REGD.

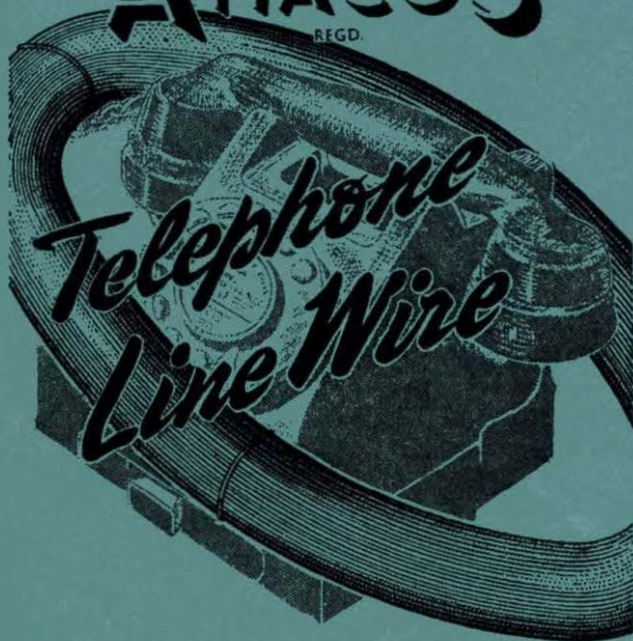

FOR THE RIGHT CONNECTION

**FREDERICK SMITH & COMPANY**

ANACONDA WORKS, SALFORD, 3, LANCS.

*Incorporated in The London Electric Wire Company and Smiths Limited,  
Associated with The Liverpool Electric Cable Co. Ltd. and Vactite Wire Co. Ltd.*

**NEW!**

**EXPERIMENTAL  
OUTFITS**

**LEARN THE  
PRACTICAL WAY**

Whether you are a student for an examination, starting a new hobby, intent upon a career in industry or running your own business—these Practical Courses are intended for YOU—and may be yours at very moderate cost



**EASY TERMS FROM £1 A MONTH**

With these outfits, which you receive upon enrolment, you are given instructions which teach you in easy stages the basic principles of the subject concerned. A tutor gives individual help and guidance throughout the Course.

**COURSES WITH PRACTICAL EQUIPMENT INCLUDE:**—Radio (Elementary and Advanced), Television, Mechanics, Electricity, Chemistry, Photography, Carpentry. Also Draughtsmanship, Commercial Art, Amateur S.W. Radio, Languages, etc.

**POST THIS COUPON TODAY**

Send me your FREE book on Practical Courses.  
To E.M.I. INSTITUTES, Dept. 22X, 43 Grove Park  
Road, Chiswick, London, W.4.

NAME .....

ADDRESS .....

IC24

**E.M.I.  
INSTITUTES**

The only Postal College which is part of a world-wide Industrial organisation.



# TELEPHONE DISTRIBUTION

## EQUIPMENT

ENGINEERS WHO ARE INTERESTED  
IN TELEPHONE DISTRIBUTION EQUIP-  
MENT ARE INVITED TO REQUEST  
SECTION T.C.13 OF OUR TELECOM-  
MUNICATION CABLES CATALOGUE.

TELEPHONE:  
SOUTHAMPTON  
2141 (5 lines).

**PIRELLI GENERAL**  
CABLE WORKS, Ltd., SOUTHAMPTON

TELEGRAMS  
"PIGEKAYBEL  
SOUTHAMPTON"

# EDISWAN

## *Telephone Line Protectors*



Surge currents induced on telephone lines by electric storms or breakdowns on neighbouring power lines may be effectively controlled by Ediswan telephone line protectors.

These special electrode gas discharge tubes have been developed in collaboration with G.P.O. Engineers to provide economical and effective protection for telephone systems without impairing the service.

Full details of these protectors and their application is given in the Ediswan publication C.1581 which is available on application.

**THE EDISON SWAN ELECTRIC CO., LTD.**  
155 CHARING CROSS ROAD, LONDON, W.C.2

*Member of the A.E.I. Group of Companies*

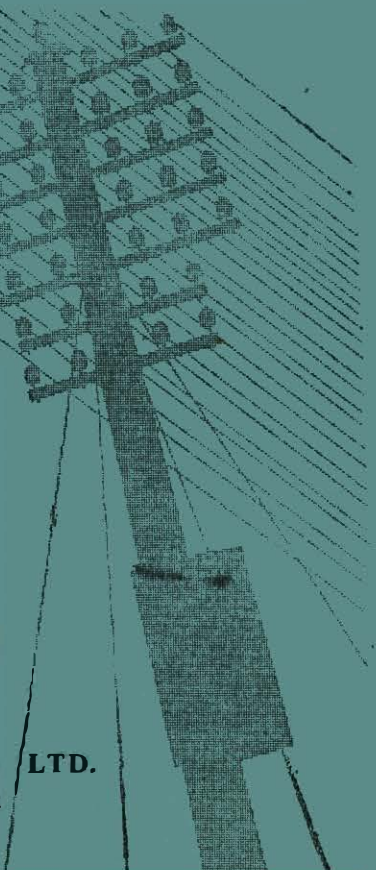

TE107