

THE POST OFFICE ELECTRICAL ENGINEERS' JOURNAL

Vol. 46

July 1953

Part 2

CONTENTS

	PAGE
THE TELEPRINTER NO. 11—C. E. Easterling, B.Sc., A.M.I.E.E., and J. H. Collins, Graduate I.E.E.	53
AN OUTLINE OF THE BRITISH TELEVISION SYSTEM, Part I—Generating the Picture Waveform—D. Wray, B.Sc.(Eng.), A.M.I.E.E.	59
THE EFFECT OF TEMPERATURE ON THE TRANSMISSION CHARACTERISTICS OF CARRIER CABLE—C. E. Palmer-Jones and I. F. Macdiarmid, A.M.I.E.E.	65
THE PROVISION OF COMMUNICATIONS FOR THE CORONATION OF HER MAJESTY QUEEN ELIZABETH II—S. M. Rousell, A.C.G.I., A.M.I.E.E., E. B. M. Beaumont, B.Sc.(Eng.), M.I.E.E., and B. H. Moore	71
THE POST OFFICE STANDARD MOTOR UNISELECTOR—C. A. May, M.A., A.M.I.E.E.	79
THE FILTERED ENGINEERING FAULT COMPLAINT AND REPAIR SERVICE—B. H. Berresford and J. Martin	83
A NEW 10-CWT. UTILITY VEHICLE—G. H. Slater, A.M.I.E.E.	86
STANDBY GENERATING PLANT FOR THE MANCHESTER-EDINBURGH TELEVISION RADIO-RELAY LINK—R. C. Marshman	89
INDUCED VOLTAGE TESTS CARRIED OUT IN CONJUNCTION WITH THE LONDON ELECTRICITY BOARD	92
A VEHICLE FOR TELEVISION OUTSIDE BROADCAST SERVICE	93
NOTES AND COMMENTS	94
INSTITUTION OF POST OFFICE ELECTRICAL ENGINEERS	94
REGIONAL NOTES	96
ASSOCIATE SECTION NOTES	99
STAFF CHANGES	102
BOOK REVIEWS	58, 64, 70, 78, 82, 85, 88

Price 2/6 net

THE INSTITUTION OF POST OFFICE ELECTRICAL ENGINEERS

How to make certain of your City & Guilds Certificates



"I guarantee tuition until you have passed"

If you consider taking one or the whole series of C. and G. examinations then I can help you. BY POST, in your own time, one of any Telecommunications specialists will coach you until you pass. He will give you individual attention, he will study you and your problems. And you will be surprised how fast you progress. For The Bennett College has specialised in technical subjects since it was founded 50 years ago. My system of personal postal tuition has helped thousands of students through their exams. It can do the same for you.

Send me the coupon to-day. I will send you—without obligation—full information on your subject.

Rep Bennett
GOVERNOR

YOU CAN START ON A BENNETT COURSE FOR ONLY **30/-**

TEAR OUT

with monthly instalments of 15/-

WHICH IS YOUR NEXT STEP?

Preliminary Course
Telecommunications Principles I—V
Telecommunications Practice
Telephone Exchange Systems I—III

Radio I—IV
Telegraphy I & II
Line Transmission I & II
Mathematics for Telecommunications I—V

Radio Servicing Certificate
Television Servicing Certificate
A.M.I. Mech.E.
and many other subjects

The BENNETT COLLEGE

To the Governor, Dept. G24, The Bennett College, Sheffield, England. I would like to have (at no cost) your prospectus on:

NAME

ADDRESS

AGE (if under 21)

PLEASE WRITE IN BLOCK LETTERS

... it goes on !



Photograph by courtesy of Imperial Chemical Industries, Ltd.

The pipelines in this 1,765 ft. tunnel (which runs under the river Tees between the two I.C.I. works at Wilton and Billingham) are all wrapped with DENSO TAPE. Due to the humid conditions in the tunnel it is essential that these pipelines, carrying chemical products and raw materials, are protected with an anti-corrosion material of proved ability. DENSO TAPE is one of our complete range of anti-corrosion, water-proofing and sealing products and we are confident we can supply the right product to meet your specific corrosion problem.



PROVIDE COMPLETE AND LASTING PROTECTION FOR STRUCTURAL STEELWORK, PIPELINES, CABLES AND ALL METALWORK BOTH ABOVE AND BELOW GROUND

Full information and technical details from:

WINN & COLEN LTD. DENSO HOUSE, CHAPEL ROAD, LONDON, S.E.27
Telephone: GIPsy Hill 4247/8. Telegrams: Denselte, Westnor, London.

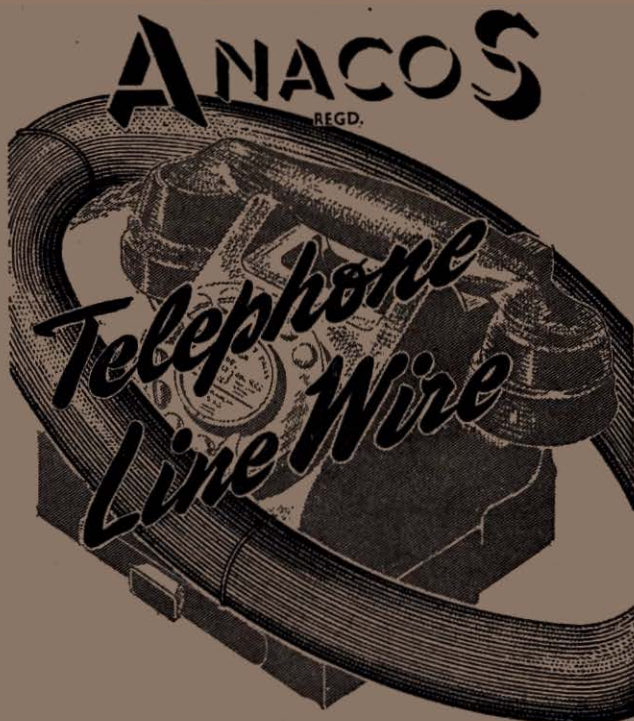

FOR THE RIGHT CONNECTION

FREDERICK SMITH & COMPANY

ANACONDA WORKS, SALFORD, 3, LANCs.

Incorporated in The London Electric Wire Company and Smiths Ltd and Associated with The Liverpool Electric Cable Co. Ltd and Yester Wire Ltd

FREE THIS VALUABLE BOOK



which details the wide range of Engineering and Commercial courses of modern training offered by E.M.I. Institutes—the only Postal College which is part of a world-wide Industrial Organisation.

Courses include training for:

P.M.G. Certificates, City and Guilds Grouped Certificates in Telecommunications; A.M.Brit.I.R.E. Examination, Radio Amateur's Licence, Radio & Television Servicing Certificates, General Radio and Television Courses, Radar, Sound Recording, etc. Also Courses in all other branches of Engineering.

E.M.I.

Institutes

associated with MARCONIPHONE

COLUMBIA

H.M.V.

(His Master's Voice) ETC.

★

COURSES FROM

£1

PER MONTH

POST NOW

Please send, without obligation, the above FREE book. E.M.I. Institutes, Dept. 22, 43 Grove Park Road, London, W.4.

Subject(s) which interest me

Name

Address

IC 108

THE POST OFFICE

ELECTRICAL ENGINEERS' JOURNAL

Vol. 46

July 1953

Part 2

The Teleprinter No. 11

C. E. EASTERLING, B.Sc., A.M.I.E.E., and J. H. COLLINS, Graduate I.E.E.*†

U.D.C. 621.394.324:621.394.6

This article gives an account of the development, features and use of the Teleprinter No. 11. Amongst other features, this machine incorporates new designs for the keyboard and typehead, an "orientation" facility on the receiving cam unit to facilitate maintenance, and an "end of line" warning mechanism. The Teleprinter No. 11 is replacing the existing Teleprinter No. 3 as the changeover from manual to automatic switching of teleprinter circuits proceeds.

Introduction.

WHEN teleprinter working was introduced into the inland public telegraph service of the British Post Office in 1928, the machine adopted was the Creed Teleprinter No. 3. This was a tape printing machine with a revolving type wheel, the type being inked by means of ink rollers which rub on the faces of the type. The keyboard layout and signalling code were almost identical to that already in use on the Murray Multiplex system; in this there is no separate "space" key, the "space" function being obtained by the depression of the "letter space" or "figure space" keys, and so inversion is always accompanied by spacing of the tape. In addition, as the machine was only intended for tape printing, no provision was made for "carriage return" or "line feed" signals. The keyboard was motor driven, the depression of a key merely serving to trip the transmitting mechanism and determine the 5-unit code combination to be transmitted, the remaining functions of setting up the code and transmitting the signals being carried out automatically. The signalling speed was 49 bauds, i.e., each unit element had a duration of 20·4 mS.

When international agreement was reached on the signalling code and speed for start-stop telegraphy, a code suitable for page printing was adopted, the "letters" and "figures" functions were divorced from the "space" function and the signalling speed was fixed at 50 bauds. By this time however, the Post Office had some two thousand Teleprinters No. 3 in service, and it was decided to retain this machine for use on the inland public network, on which it has continued to give efficient and reliable service.

The Teleprinter No. 7 was introduced in 1932 for use on Telex and private wires. This was basically a page printing machine, although it could be fitted with a tape printing attachment, and conformed to the C.C.I.T. (International Telegraph Consultative Committee) requirements referred to above. Thus, although it could not interwork with the Teleprinter No. 3, it could operate to machines constructed to the same standards by European manufacturers, and private wire and Telex subscriber working to the Continent became possible.

The Teleprinter No. 7 was similar in operation to the Teleprinter No. 3 except for such modifications as were necessary to provide page printing. There were, however, considerable changes in detail to improve reliability and facilitate maintenance. The mechanical design of the machine was based on unit construction principles which facilitated manufacture and assembly and ensured inter-

changeability of units for maintenance purposes. An ink ribbon replaced the ink rollers, giving cleaner operation and more legible printing.

The Teleprinter No. 7 is still the standard machine which the Post Office supplies to private renters and Telex subscribers, although a number of changes have been, and are still being, introduced to improve its performance. One of the most important of these was the introduction in 1939 of the "striker" transmitter, which ensures much more accurate timing of the output signals than could be obtained with the "link" transmitter which was used on the No. 3 and the earlier No. 7 teleprinters.

The question of reconstructing the public telegraph network on an automatic switching basis was under very active consideration in the years preceding the war and field trial equipment had been designed and tested. At that time it was intended to employ Teleprinters No. 3 as the operating instruments. All work on the project had to be abandoned during the war years, but the matter was immediately reopened on the cessation of hostilities in 1945. In the following year it was decided that the teleprinters to be used on the network should conform to C.C.I.T. standards, so that there would be no restriction on future extension of the system to private or international switching networks. Certain additional features, not available on the Teleprinter No. 3 without extensive modification, were required to enable the machine to operate over an automatically switched system, and it was decided to adopt a new teleprinter which was under development by Creeds at the time, and on which the additional features could be incorporated. This was the Creed Model 47, which became the Post Office Teleprinter No. 11.

The first prototype machine was inspected at various stages of its construction and towards the end of 1947 a sample model became available for tests by the Post Office. This machine did not embody all the features required for automatic switching, but a limited number was purchased and installed on point-to-point circuits so that field experience of the new machine could be obtained at an early stage. These machines were known as the Teleprinter No. 11A.

Meanwhile development of the additional facilities went on, and some 250 machines embodying all the required features were brought into service when the first automatic switching centres were opened at London North and Birmingham in October, 1950. These machines were designated Teleprinters No. 11B. A further 2,000 machines have since been purchased in preparation for the expansion

*† The authors are, respectively, Senior Executive Engineer and Executive Engineer, Telegraph Branch, E.-in-C.'s Office.

of the automatic switching scheme during 1953-1954.

During the development of the Teleprinter Automatic Switching System it became apparent that it would be an advantage if the teleprinters installed on the engineering test positions, which were necessarily Teleprinters No. 11B in order to provide the required terminating facilities for automatic speaker circuits, could also inter-operate with Teleprinters No. 7 on private wires which could be routed through the same engineering control board. It was also desired to use Teleprinters No. 11 on the switchboard positions on the Inland and Continental Telex systems, because the visibility of the printing was much better than that of the Teleprinter No. 7 with tape attachment, and to extend their use to the manual switchboards used with various private wire networks. The keyboard layout and signalling code already conformed to that of the Teleprinter No. 7, so that all that was necessary was the addition of an "end of line" mechanism and warning lamp. Machines with this facility are known as Teleprinters No. 11C, and 450 have now been purchased by the Post Office. Fig. 1 shows one of



FIG. 1.—TELEPRINTER NO. 11 WITH COVER ON.

the machines with its cover in position and carrying a message tray with two compartments.

General Design Features.

The Teleprinter No. 11 is largely of orthodox design and makes use of many of the mechanisms and principles of operation employed in the Teleprinter No. 7, and in fact a large proportion of the parts are common to the two machines. Fig. 2 indicates the principal units included in the new machine.

The keyboard, described in more detail later, is a departure from previous designs, being of the "saw tooth" type in which the operation of depressing a key, in addition to releasing the transmitting mechanism, positions the combination bars which determine the code to be transmitted. The merit of this arrangement lies largely in the "touch" and in the fact that the keyboard is automatically locked against the depression of a second key without the need for a separate locking bar.

The transmitter is of the "striker" type similar to that used on the Teleprinter No. 7, but with the components rearranged to operate from the saw-tooth keyboard.

On the receiving side some improvements in the design of the electromagnet have been introduced, increasing the stability and facilitating adjustment. The selecting mechanism embodies an orientation device which provides a means of checking and centralising the receiving margin. An improved typehead clutch has also been introduced.

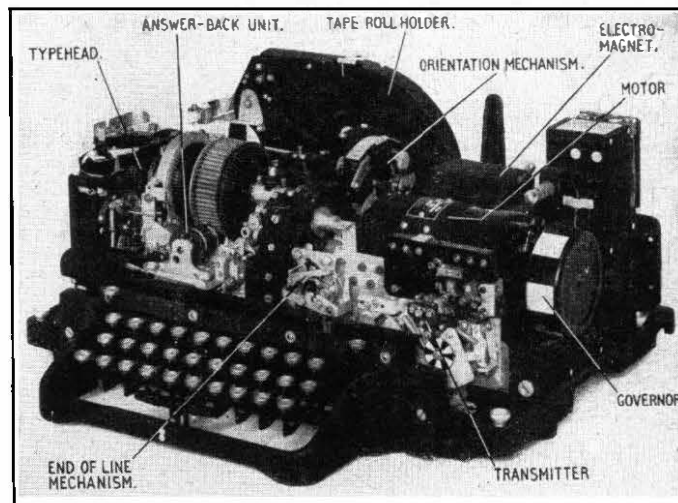

FIG. 2.—FRONT VIEW OF TELEPRINTER NO. 11; COVER REMOVED

Of general interest is the widespread use of new materials and manufacturing techniques. Great use has been made of zinc alloy (Mazak) die castings for smaller parts. This process permits the manufacture of large numbers of parts to extremely close dimensional tolerances. In contrast to the Teleprinter No. 7, ball bearings are used for only four of the main bearings, oil impregnated sintered bronze bushes being used for the remainder and also for many of the minor pivots.

The Keyboard.

The principle of operation of the saw-tooth keyboard is illustrated in Fig. 3 from which it is seen that a particular keybar when depressed engages with the sloping edges of triangular projections on each of the five combination bars and a trip bar. The combination bars are thus moved to the right or left as required for the particular code sequence to be transmitted, while the trip bar is moved to the left to release the transmitter mechanism. The layout of the keys finally adopted conforms to that used on the Teleprinter No. 7 except that the "WRU" signal, which is the secondary case of letter D, is provided on a separate key, and a shift lock bar operated by the "figures" and "letters" keys ensures that the D key cannot be depressed following a figure shift, which, of course, would result in the sending of a WRU signal. This feature, and the placing of the WRU key at the rear out of the normal key field, guards against the accidental sending of a WRU signal and the consequent release of the distant answer-back during operating. Two additional keys have, however, been added, namely a "Here is" key and a "Run out" key. The depression of the "Here is" key releases the answer back unit so that the answer back code may be transmitted at will to the distant end of the circuit. The "Run out" key provides continuous transmission of any chosen character from the transmitter, the character sent corresponding to the last character key depressed. This is possible because the combination bars on the saw-tooth keyboard are not restored to one side at the end of each character transmission, as in the motor driven keyboards used by the Post Office on Teleprinters Nos. 3 and 7, but remain in the position corresponding to the last character sent. The operation of the "Run out" key releases the transmitting cam and consequently causes the continuous transmission of this character until the key is released.

The keyboard used by the Post Office employs three rows of keys, and each key, with a few exceptions, is used to transmit two characters, the primary being a letter and the secondary a figure, punctuation sign, etc. The change of case at the receiving machine is controlled by the operation of the "letters" or "figures" key, and failure to perform

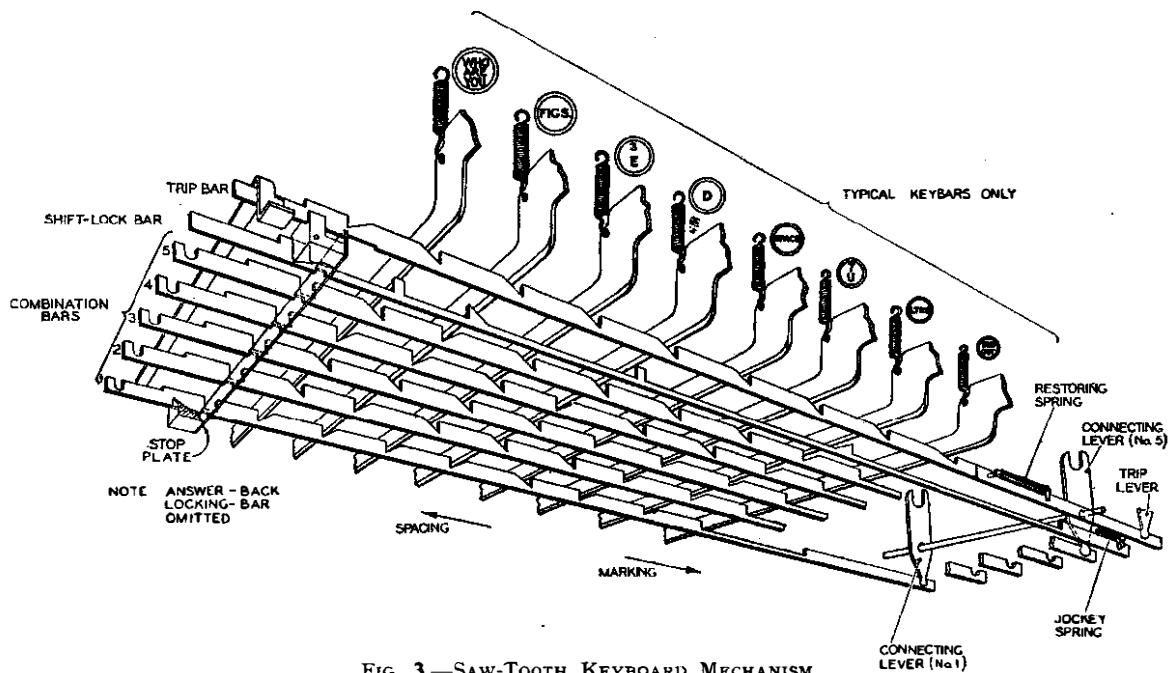

FIG. 3.—SAW-TOOTH KEYBOARD MECHANISM.

this operation will result in incorrect reception. It may be of interest to mention that a keyboard has been designed by Creeds which eliminates this cause of error but at the expense of an increase in size and complexity. In this keyboard, which uses four rows of keys, the first three rows are used for letters only, the keys in the fourth row being used for figures in the primary condition and punctuation signs, etc., in the secondary condition. When the "letters" key is depressed the keys in the fourth row are locked against operation, and when the "figures" key is depressed the keys in the first three rows are locked. In order to transmit the secondary character of a key in the fourth row a separate manual shift key must be held depressed.

Another interesting variant of the saw-tooth keyboard, which may also be fitted to the Teleprinter No. 11, has been produced by Creeds, principally for alphabets with more than 26 letters. When such alphabets are employed with the standard start-stop 5-unit code, it is necessary to place one or more letters in the "figures" case. To avoid the necessity of memorising these letters, a specially designed transmitter can be supplied which automatically inserts the correct case-shift signals whenever the operator changes case.

The Orientation Facility.

An innovation of importance from the maintenance aspect is the provision of an orientation facility on the receiving cam unit. The actual cam is made identical, as regards cam tracks and period of revolution (130 mS), with that of the Teleprinter No. 7 but the rest position as determined by the retention pawl is advanced approximately 22 mS. A mechanical delay system (see Fig. 4) incorporating a clutch-driven cam and giving a delay adjustable between about 12-32 mS is introduced between the electromagnet armature and the receiving cam pawl abutment. With the delay mechanism in its mean position the receiving cam therefore starts to rotate some 22 mS after the commencement of the start signal and comes to rest again 130 mS later. This, of course, does not interfere with the normal start-stop operation of the teleprinter. The orientation device enables the selection periods of the receiving cam to be centralised with respect to the five code elements of the incoming signal so that the teleprinter can be adjusted to the optimum state for receiving signals over a

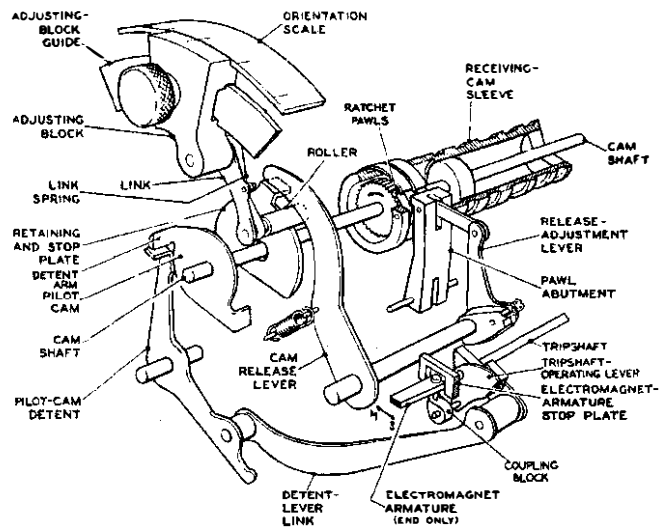

FIG. 4.—ORIENTATION MECHANISM.

particular line. In a switched system, in which a machine must receive signals equally well over any circuit, the use of the facility is of limited value but by connecting the teleprinter "in local" an approximate check of receiving margin can be made. On previous teleprinters there had been no ready means of checking margin in the field and the advantage of providing a margin testing feature for maintenance and also the desire to assist the manufacturers in standardising their production led to the adoption of the facility.

The Typehead.

The typehead of the Teleprinter No. 11 is a complete departure from previous design. The construction of the driving clutch and the latch mechanism is shown in the assembled and exploded views given in Figs. 5 and 6. The stop arm and the latch arm are assembled scissor fashion on the typehead spindle together with oilite friction washers, the whole being sandwiched together by the stout axial compression spring. Two shock absorbing springs are inserted between the cups mounted in the two arms. When released the typehead is driven by a clutch of the conventional drum type which slips when the typehead is latched to

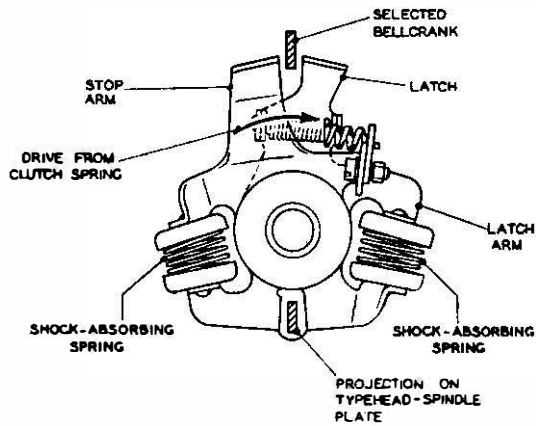

FIG. 5.—THE TYPEHEAD; ASSEMBLED.

a "fallen" bellcrank. In the latched position the bellcrank is gripped between the stop face of the stop arm and the latch on the latch arm while the rear ends of the two arms grip a projection on the typehead spindle and thus locate the type racks. The initial shock of the impact between the stop arm and the "fallen" bellcrank is absorbed by the two shock absorbing springs. After impact the two arms make two or three oscillations about their common axis before coming to rest gripping the bellcranks, during which interval the energy of rotation temporarily stored in the shock absorbing springs is dissipated in overcoming the mutual friction developed by the compression spring. In order to allow time for these oscillations to be damped, the speed of rotation of the typehead shaft has been made greater than on the Teleprinters No. 3 or 7.

The performance of the new typehead clutch has been very satisfactory, the fault rate being about one eighth of that of the clutch previously used on the Teleprinter No. 7. As a matter of interest it may be mentioned that Teleprinters No. 7 are now fitted with a similar clutch.

Tape Feed Mechanism.

Experience with the Teleprinter No. 3 had shown that some changes in the tape feeding mechanism were desirable. In the Teleprinter No. 3 the roll of tape is housed inside the cover and the heat generated by the motor frequently causes cockling of the paper with a consequent liability for turns to come off the roll and become jammed in the tape roll holder. The tape roll holder of the Teleprinter No. 11 has, therefore, been mounted outside the cover; this has the additional advantage that a new roll of tape can be fitted without removing the teleprinter cover.

The inking of the types is effected by means of an ink ribbon, in place of the ink rollers used on the Teleprinter No. 3, which, although mechanically simpler, are not so satisfactory in use. The whole of the casting on the left-hand side of the machine, which houses the ink ribbon, platen and paper feed mechanism, is hinged at its base so that it may be swung outwards away from the typehead for maintenance operations.

Paper Failure Alarm Mechanism.

In order to effect operating economies it is an advantage to be able to rely on the reception of the answer back at the office of origin at the beginning and end of a transmission as

a sufficient acknowledgment of receipt of the message at the office of destination, and thus to dispense with continuous attendance at the receiving machine. Under these conditions failure of the paper to feed correctly could cause message failure and a reliable paper failure alarm is essential. As it was further decided that the operation of the alarm should release the switched connection as an indication to the sending operator, it was also essential that the alarm should not be prone to false operation, otherwise artificial traffic in the form of repeat calls would be created.

In order to appreciate the problem fully it is necessary to define the fault conditions to which the alarm mechanism must respond. These are (a) breakage of the tape, (b) jamming of the tape not followed by breakage, (c) failure to feed the tape sufficiently so that overprinting of successive characters occurs. The device incorporated by Creeds in their original Model 47 prototype was designed with these

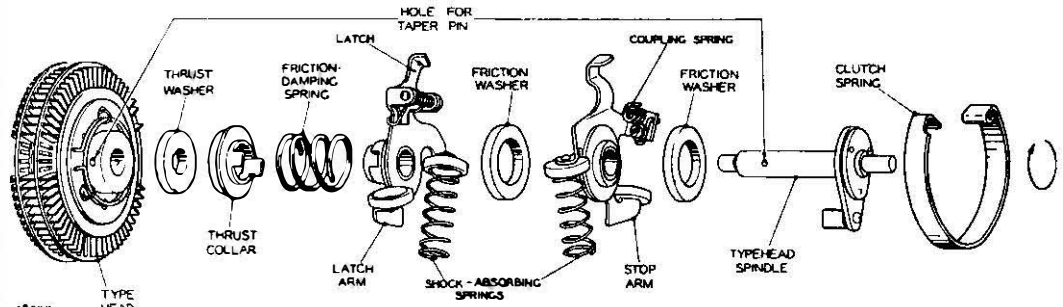

FIG. 6.—EXPLODED SKETCH OF TYPEHEAD.

requirements in mind but subsequent tests showed that it was liable to false operation either during or following manual feeding of the tape, whether by turning the tape feed knob or pulling the tape from the machine. Since a manual feed operation is the normal procedure in order to get the end of a message out, it followed that the first paper feed movement of the subsequent message was likely to be defective and the alarm operated. Another factor which contributed to indeterminate operation of the paper failure alarm was the presence of slack tape between the tape roll holder and the alarm mechanism. This was overcome by redesigning the roll holder with a simple brake mechanism controlled by the tape tension which may be seen in the top right-hand corner of Fig. 7.

The elements of the alarm mechanism finally adopted are shown in Fig. 8. The tape is taken off the roll holder on the left (not shown) and is moved to the right by the tape feed

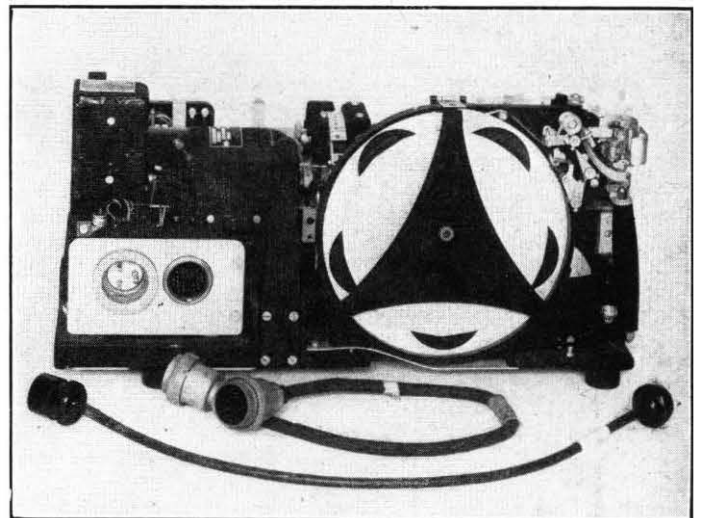

FIG. 7.—REAR VIEW OF TELEPRINTER NO. 11; COVER REMOVED.

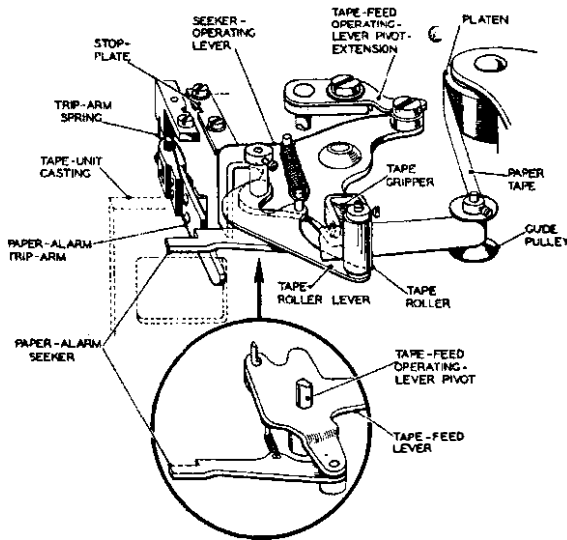

FIG. 8.—PAPER-FAILURE ALARM MECHANISM.

mechanism. The tape is lightly gripped, over its full width, by the spring-loaded jaws of a tape gripper mounted on a pivoted member known as the seeker operating lever. This lever is reset to the left-hand position against a stop plate at the end of each tape feeding operation and is moved by the tape during the subsequent tape feed, the movement being proportional to the tape feed. A projection on the seeker operating lever bears against the paper alarm seeker moving it forward. Simultaneously the seeker is withdrawn to the right during the forward movement of the tape feed ratchet pawl and is moved back to the left during the return motion. If the step at the end of the seeker has not moved sufficiently forward to clear the shoulder on the paper alarm trip arm the latter is displaced and in turn releases a spring-loaded contact operating lever. The forward movement of the seeker is determined by the actual movement of the tape and the design and the adjustments are such that the alarm contacts are operated when the paper movement is somewhat less than half of normal. This degree of overprinting may be tolerated as it represents the condition in which adjacent characters just touch. It should be mentioned that the tape feed ratchet pawl is adjusted so that in the normal rest position there is a lost motion equal to half a tooth pitch. This ensures that however the pawl may be left relative to the ratchet (e.g., by manual operation of the feed knob) the resultant feed cannot be less than one half normal unless a genuine paper fault condition exists.

When a paper alarm condition is set up it is cleared automatically, as far as the machine is concerned, when the next normal tape feed occurs although it is maintained by the position equipment until attended to and a reset key operated. This eliminates the need for any manual alarm resetting facility on the teleprinter itself.

The Motor.

In the automatic switching system as developed by the Post Office, the teleprinter is switched on at the beginning of each call and switched off at the end. In addition, the transmission of the answer back from the receiving machine at the beginning of a call is initiated automatically. It is therefore necessary for the machine to reach its full operating speed in a very short time, and the design features of the scheme imposed an upper limit of one second for a machine to reach its governed speed.

After a considerable amount of work had been done on the measurement of motor starting times and investigation of the possible causes of slow starting it was decided to redesign the motor windings, taking full advantage of the

motor frame size to obtain a higher starting torque. The result was a more powerful motor which met the starting time requirement but, as experience has now shown, at the expense of some reduction in brush life. Further investigations are now being carried out to attempt to effect an improvement and some promising results have been obtained using brushes of a different grade of carbon.

The motor used by the British Post Office is a two-range D.C. motor wound for 160V and 200-250V. Motors for other voltages, both A.C. and D.C., are available, though they would not necessarily meet the requirement for a starting time of one second.

Check of Motor Speed.

The means available for measuring teleprinter speed had long been considered in need of improvement, and the introduction of a new teleprinter afforded the opportunity for adopting new methods. It was ultimately decided to provide a twofold check of speed, firstly by a speed test circuit in the switching centre transmitting reversals at a definite frequency, access to which could be obtained by dialling a specified number* and secondly by a tuning-fork-type stroboscope. The first was intended for routine checking of speed and accurate final adjustment of the governor; the second for use by a mechanic while adjusting a governor, to avoid holding the speed test circuit for an excessive period, and also for use where there was no access to the speed test number. Fundamental considerations led to different frequencies being chosen for the two methods, the band width of V.F. channels limiting the frequency of the speed test signal, and size and cost precluding a tuning fork of too low a frequency. Frequencies of 20 c/s and 150 c/s, respectively, were eventually chosen as most suitable from a variety of points of view including the available shaft speeds on the teleprinter, technical considerations in the production of tuning forks and the generation of signals by the signal generators at a switching centre. Two sets of stroboscopic markings were therefore provided on the teleprinter; six segment markings on the governor cover for use with the tuning fork and a six segment disc on the transmitter shaft for use with the speed test number. The latter can readily be made to revolve continuously by depressing the run-out key.

Connecting Cords.

The long cords generally fitted to teleprinters are inconvenient when the machine has to be moved or packed for transport. It was therefore decided that on Teleprinters No. 11 supplied to the Post Office the power and signalling connections should terminate on shrouded pin jacks on the machine and double-ended cords would be used for making the connection to the position equipment (see Fig. 7). These cords remain on the position when the machine is removed.

"End of Line" Indicator.

An end of line mechanism and warning lamp were already available on Creed's standard machine. This indicator was therefore adopted after test, and its basic elements are illustrated in Fig. 9; machines thus fitted are designated "Teleprinter No. 11C".

The mechanism counts each character transmitted, including the non-feed characters, lights a lamp after 55 characters have been sent and restores when the carriage return key is depressed. The end of line counter parts are mounted on the same base plate as the transmitter. A cam track on the transmitter moves link AR (Fig. 9(a)) to the right once per revolution of the transmitter and in doing so causes a feed pawl, FP, to rotate ratchet wheel R one tooth.

* P.O.E.E.J., Vol. 44, p. 107.

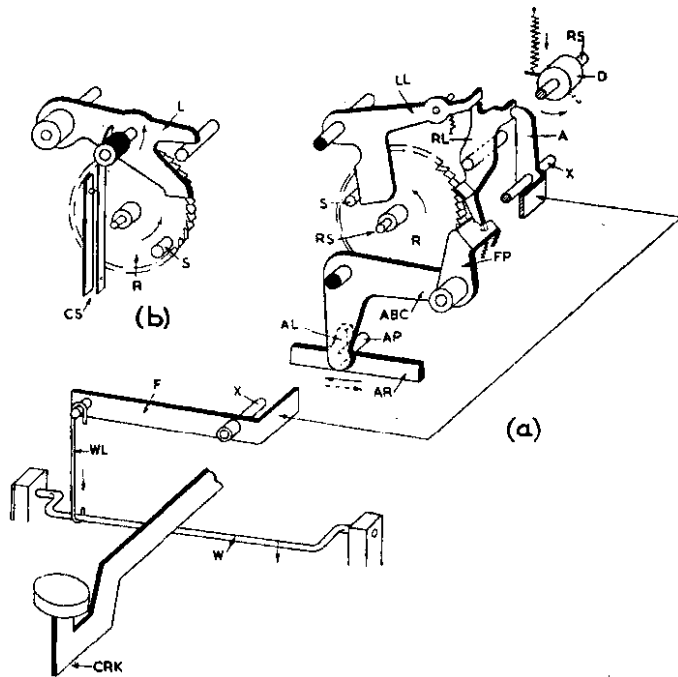

FIG. 9.—“END OF LINE” MECHANISM.

A retaining pawl, RL, prevents backward movement. As the ratchet wheel rotates a spring is elongated and partially wrapped round a drum, D. After 53 teeth have been fed stud S (Fig. 9(b)) touches contact operating lever L, and after 55 teeth the contacts CS are fully operated. The periphery of the ratchet wheel is left blank after 55 teeth to prevent further rotation. When the carriage return key, CRK, is depressed (which of course may occur at any time) the cranked trip rod W is rotated and in turn causes the operation of the resetting lever (F and A). This in turn displaces RL which is held out by a latch, LL. The ratchet wheel is thus free to restore under the tension of the spring, and the lamp contacts are opened. At the end of the movement of the ratchet wheel, S strikes LL and releases RL. A damping buffer (not shown) is provided to absorb the shock of the return motion.

The end of line indicator lamp is mounted on a bracket above the governor and shines through a red faceted glass window in the front of the cover. It is sufficiently bright to attract the attention of the operator under the worst room lighting conditions. The choice of a suitable lamp caused some difficulty due to destruction of the filament by vibration and it was early found that a 160 V lamp had an exceedingly short life. Eventually a 6V, 0.3A filament lamp was selected as being the only standard item suitable.

Further Developments.

It will be appreciated that in a machine of the complexity of a teleprinter continual development work is proceeding to improve performance, facilitate maintenance and simplify

manufacture. Such changes are introduced as soon as possible on new machines during manufacture, and may be applied to old machines during normal maintenance visits or overhaul if the cost is considered to be justified.

As already mentioned many parts are identical with Teleprinter No. 7 parts and some of the development work has been on parts common to both machines. A friction clamped speed adjusting screw, for example, has been introduced on the governor, with an access hole in the governor cover to facilitate maintenance. A more recent innovation has been the redesigned electromagnet unit the main features of which are the hardened steel stops on the armature, a stop plate rigidly mounted on the unit casting, oil impregnated bearings for the armature, a means of adjusting the polarising flux and the addition of a cover.

A further change, approved but not yet implemented, concerns the paper failure alarm parts which, as can be seen in Fig. 1, overhang the left-hand side of the machine. This arrangement is somewhat unsightly and there is a certain risk of damage during handling. By careful redesign Creeds have been able to produce a more compact mechanism.

An important point on which development effort is now being concentrated is the abatement of noise. Although the Teleprinter No. 11 is not appreciably noisier than many other machines in the same class, the modern tendency is to demand a lower noise level in offices than has been accepted in the past. This is particularly important where the teleprinters are installed adjacent to phonogram positions. The problem has been tackled by the Post Office and Creeds with the object of reducing the noise at source, but although this focused attention, for example, on the advantage of obtaining a greater accuracy in the cutting of gears than had been required in the past, the best results have so far been obtained by standing the machine on a felt pad and lining the dust cover with hessian to damp its vibrations. Further development is now proceeding towards enclosing the machine completely in a new type of dust cover. The machine is resiliently mounted on a rigid sub-base on which the cover is also resiliently mounted, and the vibration of the machine is thus insulated both from the cover and from the table. Promising results have been obtained with the first sample, which possesses good sound reducing qualities but adds little to the overall dimensions or weight of the machine as compared with the present cover.

Conclusion.

The 250 Teleprinters No. 11B referred to in the introduction have now been in use for over two years. They have given very satisfactory service and show a fault liability somewhat lower than that of Teleprinters No. 7. As a result of experience on these machines and also on the Teleprinters No. 11A some modifications to design have been made on those parts which produced the larger proportion of the faults, and it is expected that machines from later production will show an improved performance.

Book Review

“Power Cables: Their Design and Installation.” C. C. Barnes, A.M.I.E.E., A.I.I.A. Chapman & Hall. 272 pp. 68 ill. 35s.

This is the fourteenth volume of a series of monographs on electrical engineering.

It is a businesslike book of 272 pages and there are nearly 70 tables giving an impressive amount of technical detail of power cables. Much of the mathematics has been reserved to appendices and a good balance between theory and practice has been maintained. The book is very readable. There is a bibliography of 111 references. The chapter headings include:—Design Requirements, Core Identification and Assembly, Mechanical Protection, Power Cable Testing Requirements,

Calculation of Permissible Current Rating, Intermittent Rating, The Effect of Short Time Peak Loads and Short Circuits on Cables already Loaded, Oil-filled and Gas Pressure Super-Voltage Cables, Overseas Super-Voltage Cable Development, Power Cable Manufacture, Installation, Effects of Grouping, Jointing and Terminating, Cable Faults, Modern Submarine Power Cables, High Voltage Direct Current Transmission, Care and Maintenance.

As so many people find that “one look is worth a thousand words” it is to be regretted that most of the photographic illustrations are too reminiscent in size and quality of the early cigarette pictures; otherwise this is a very good book for the engineer concerned with the distribution of electricity.

A. E. P.

Part I.—Generating the Picture Waveform

U.D.C. 621.397.5

This is the first of three articles in which the British television system is to be described in outline, and which will deal in turn with the generation, transmission and reception of the picture signal waveform. An account is given in this part of the general principles by which an electrical signal representing the brightness variation in any scene is obtained. The processes of scanning and synchronisation are described, as well as the operation of a television camera, and general studio techniques and practices. Television standards particular to the British television system are referred to throughout.

INTRODUCTION

TELEVISION has been associated with other forms of telecommunications since 1876, when Bell's invention of the telephone was almost immediately followed by a flood of learned papers describing systems—mostly impracticable—for the transmission of vision by electrical signals. Today, side-by-side with its concern in telephony and its active interest in sound broadcasting in this country, the Post Office controls an extensive television transmission system that forms an appreciable part of its responsibilities.

As the purpose of a television system is to extend the range of the eye beyond its normal limits, presumably an ideal television scheme would enable the viewer to see whatever he liked no matter how far away. This, however, might have undesirable social and international consequences. In the television systems now in general use it is left to programme-planners and producers to decide *what* is to be seen; *how* it is to be seen is a problem for the engineers, for whom, very often, the greatest difficulty is to decide at what point to compromise between the quality of the picture that they finally display to the viewer and the cost and reliability of their systems. For countries intending to establish a national television coverage, it is essential to decide at an early stage the standards of the system that is to be adopted, so that those responsible for the broadcast transmitters and studio equipment, the point-to-point transmission engineers and the manufacturers of domestic receivers, can all work together in co-operation.

Nearly all television systems intended for broadcast transmission employ the same basic principles for their conveyance of vision, but the standards adopted (i.e., the compromise between quality and cost) vary from country to country. It is intended in this series of articles to describe in general terms the British television system, both in regard to its fundamentals, which are universally applicable, and to the standards peculiar to this country.

GENERAL PRINCIPLES OF TELEVISION

Requirements.

It has been mentioned that television extends the normal range of the human eye, and, indeed, it may be thought of as an enormous ophthalmic system: the camera, with its lens, iris and mosaic, represents the lens, iris and retina of the eye; the cable and radio transmission of the television signal is equivalent to the optic nerve connecting the eye to the brain; and the final conversion by the television receiver of the broadcast signals into a picture on the screen can be equated to the conversion of the optical signals in the brain to give the visual sensation. For a television system to be effective, therefore, it should perform the same functions as the eye. For people with normal vision, the eyes register four distinct impressions:—

1. the distribution of light and shade in the viewed scene;
2. the motion of the objects in the scene;
3. the colour distribution in the scene;

4. the relative distances in depth of the objects in the scene (the third dimensional or stereoscopic effect).

The last two items in this list are comparatively unimportant. Although it is by no means beyond the power of television to produce pictures in colour and with the appearance of depth, such facilities are luxuries, for considerable information, and even entertainment, can be derived from a picture without them. But even allowing for the simplification that attends the omission of colour and stereoscopy, television cannot display a picture just as the eye would see it, for, in any purely optical method of viewing a scene, such as a camera obscura or a telescope, the view is continuous both in space and time. That is, the brightness of the scene is a function of three co-ordinates, two in space and one in time; no means of electrical transmission, be it by cable or by radio, in which there are only two related parameters—time, and the instantaneous voltage of the signal—can transmit this continuous three-dimensional scene. However, this difficulty can be overcome by exploiting some of the limitations and peculiarities of the human eye.

Image Analysis.

One property of the eye which is made use of is the "persistence of vision," a name given to the prolonging of the visual impression for a time of about 1/30th of a second after the original stimulus has been withdrawn. If a series of still pictures each representing a scene in successive stages of movement, is displayed to the eye, the onlooker is cheated into believing he is seeing a continuously changing picture. This is one of the basic principles of cinematography. It has been found that it is necessary to show the separate pictures at a rate of about 16 a second to produce the illusion of continuous movement (24 frames/sec. are displayed in the cinema) but the flicker due to the light source being interrupted—a completely different effect—is still obvious at this frequency. Cinema films overcome the latter difficulty by employing a shutter that displays each picture twice, thus increasing the flicker rate to nearly 50 times a second, an unobjectionable value.

In this way the effect of movement can be simulated by sending in rapid succession a number of still pictures; but each of these still pictures represents a scene which can change in brightness continuously over its surface, and which cannot, therefore, be transmitted over a single communications channel. Here a second property of the eye is exploited—the acuity, the limit of fine detail that the eye can resolve.

Very few people can detect a change in detail that subtends an angle of less than 1 minute of arc at the eye. Consequently, if a picture is divided into a number of small elements, each of a certain brightness, there will be a certain viewing distance at which these elements subtend the limiting angle of 1 minute of arc at the eye, and so represent the finest detail that the eye can resolve. Thus if it can be arranged that the television camera breaks up the original scene into a large number of separate elements, and then

† Executive Engineer, Radio Experimental and Development Branch, E.-in-C.'s Office.

transmits in turn an electrical signal corresponding to the brightness of each of these elements, provided they are re-assembled in the same order on the screen of the receiver with the same relative brightnesses, there will again be a viewing distance where the received picture will present as much detail as it is possible for the eye to see. This is demonstrated in Fig. 1. Just as the persistence of vision

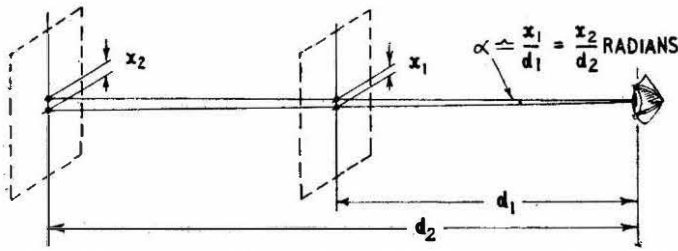

(a) Visual Acuity—expressed by the smallest angle at which the two dots are separately visible.

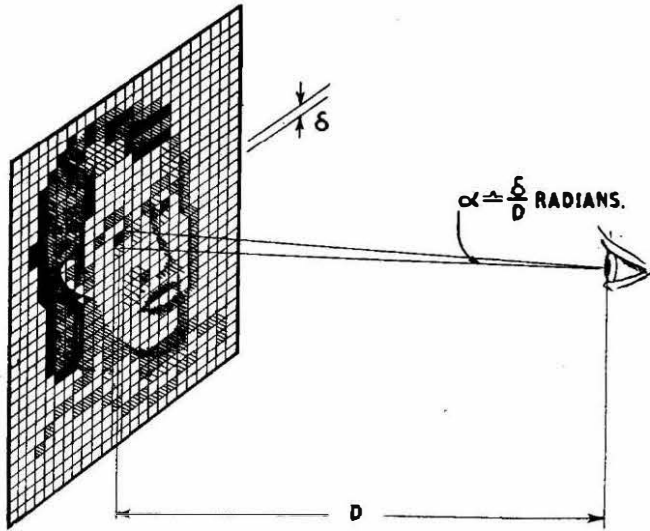

(b) Viewing Distance.—When the viewing distance is such that a picture element subtends the smallest angle to the eye that is distinguishable, the picture appears adequately detailed.

FIG. 1.—VISUAL ACUITY AND IMAGE STRUCTURE.

enables continuous movement to be achieved by breaking the scene into a number of still pictures, so does the acuity limitation enable a continuous change of brightness in space to be simulated by a number of small separate elements. Any method of selection of these picture elements may be used, so long as the same sequence is followed in both the camera and the receiver. Nowadays the method universally adopted is the "linear scanning" system.

Scanning.

In the scanning process, the many picture elements into which the picture is divided are considered as lying along a large number of horizontal lines; the camera "reads" along these lines—almost as though the picture were lines of print—starting at the top left-hand corner of the picture and moving at a constant speed to the right-hand edge, then returning rapidly to the left-hand edge of the next line down, and so on until the bottom right-hand corner of the picture is reached. In this way the whole picture area is systematically scrutinised, with the camera converting the brightness of the particular element under examination into a corresponding voltage as it scans along the lines. This is demonstrated in Fig. 2 in which a very elementary television system with only 10 scanning lines is being used to scan a picture of a pig in a sty. As the camera scans along the second line, the voltage output from the camera is kept nearly constant to represent the uniform greyness of the sty, with sharp positive-going pulses of voltage as the ears

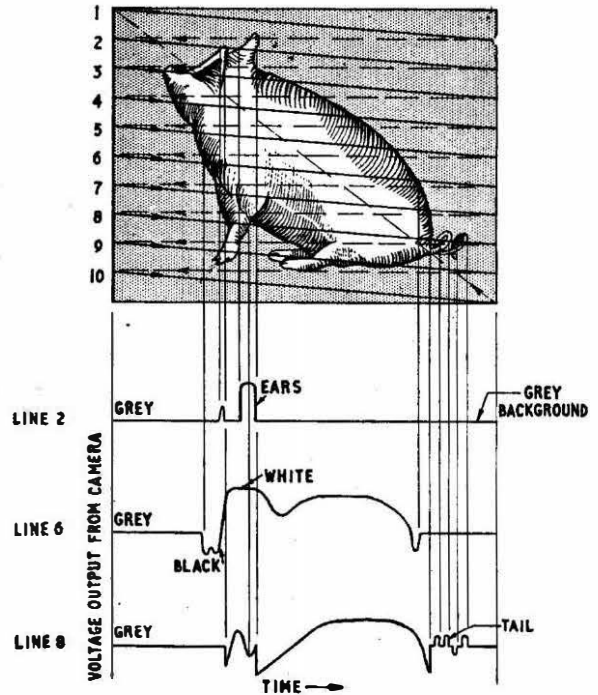

FIG. 2.—SIMPLE SCANNING SYSTEM.

are passed; the sixth line has a slow rise and fall of voltage to correspond with the light and shade of the pig's body; and the eighth line contains some complicated voltage variations to represent the detail in the animal's tail. The early television systems were very nearly as crude as this—the original Baird mechanical-optical system had only 30 lines—but in modern systems it is necessary to have several hundred lines to produce an acceptable picture.

To compose a picture from a number of lines means that any one fragment of the scene is only instantaneously under review by the camera, and that the camera's scrutiny must move rapidly from side to side and more slowly from top to bottom. At the same time, in the distant receiver a spot of light moves across the screen exactly in step with the camera scanning process, with brightness of the spot controlled indirectly by the instantaneous voltage developed by the camera, so that a representation of the original scene is built up on the face of the screen. The frequency of the comparatively slow vertical scanning corresponds approximately to the rate at which still pictures are changed in the cinema to give an appearance of continuous motion, with the difference that each "still" picture is not a continuous photograph but is made up of a large number of horizontal lines. So the phenomenon of the persistence of vision is exploited even more in television than in the cinema, for what appears to be a continuously moving picture is, in fact, a tiny fast-moving spot of light. A further difference from cinematography is that two points on a television picture do not necessarily represent the corresponding points in any single photograph of the original scene, for during the finite time taken to scan the scene once, movement may have occurred in the subject.

British Scanning Frequencies.

The pattern of horizontal lines traced out by the spot of light on the screen of a television receiver is known as a "raster"; it must be precisely the same as the pattern in which the camera scans the original scene. In the British television system the spot is deflected horizontally at a rate of 10,125 lines per second (the "line frequency"), and vertically at a rate of 50 per second (the "frame frequency"),

so for each vertical traverse of the raster there are $10,125/50 = 202\frac{1}{2}$ horizontal lines. The effect of the odd half line is to prevent the lines in two successive vertical traverses from being superimposed; instead, they interleave to form a raster having 405 horizontal lines repeated at a rate of 25 per second. This scheme is illustrated in Fig. 3. This system,

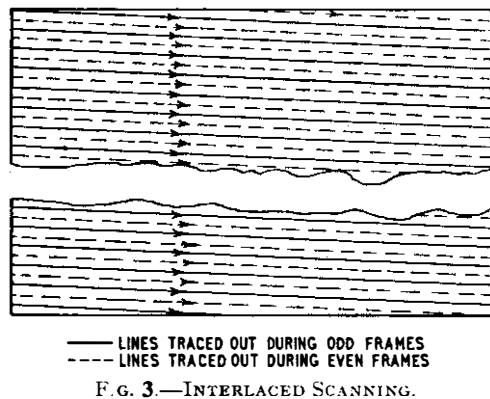

known as "interlaced scanning", has the advantage of displaying complete pictures at a rate of 25 per second but having a flicker rate of twice this value.

Picture Proportions.

A further factor which it is essential to standardise is the ratio of the width of the picture to its height, or the "aspect ratio" as it is called. To take an extreme example: if our pig of Fig. 2 were to be viewed by a camera scanning a square raster, and then displayed on a receiver screen twice as wide as it is high, the received pig would appear long and thin, like a weasel. In this country the aspect ratio is standardised at 4:3; this is generally supposed to produce a rectangular picture of pleasing proportions, and, moreover, is in agreement with the aspect ratio of the cinema film, which forms an important part of television subject matter.

Bandwidth.

We have seen that a convenient way of splitting the original picture into tiny elements of brightness is to scan the picture in horizontal lines. Obviously, the more lines there are the more detail can be displayed in the vertical direction; and if there is to be as much detail in the horizontal direction as there is in the vertical then the elements along the line must be of the same size as the distance between the lines. The maximum possible rate of change of brightness should then be the same horizontally and vertically. The most detailed picture that a television system can transmit is, therefore, a draught-board pattern made up of black and white squares in which the number of horizontal lines of squares is the same as the number of scanning lines. As the camera scans along these lines it will generate a voltage reversal or cycle for each consecutive black and white square, so clearly the highest frequency of A.C. necessary to convey the picture signals is a function of the number of scanning lines. The lowest frequency to be transmitted must represent the slow general brightness variation in the scene, that is, almost down to D.C.; a stationary picture will, in fact, have D.C. present but no A.C. components between D.C. and the picture repetition frequency (25 c/s). The frequency band between this lowest frequency and the highest frequency previously mentioned is the "bandwidth" necessary to convey the television signal. Now, if the number of lines in the picture is increased—imagining the frame frequency to remain constant—the time available for each line to be scanned is decreased

correspondingly, and there must now be more elements along each line to bring the horizontal detail up to the new vertical standard; the camera must now scan more elements in less time, so the net effect is that the bandwidth is proportional to the *square* of the number of scanning lines.

If all the equipment involved in the long chain between the scene and the screen is to be as simple as possible, the number of lines in the picture should be as small as possible whilst still giving a reasonably detailed picture. In the British system the 405-line raster has been chosen as providing a reasonable compromise between the two opposing factors of detail and bandwidth, or quality and cost. The British system requires a bandwidth extending from D.C. to 3 Mc/s for satisfactory transmission.

The figure of 3 Mc/s, given as the highest frequency required by the British television system, is derived in this manner: there are 405 horizontal lines which occur 25 times in a second; in each of these lines there should be the same number of horizontal elements as there are vertical, i.e. $405 \times$ the aspect ratio of the picture. Therefore, the number of elements per second is $25 \times 405 \times \frac{4}{3} \times 405 = 5,470,000$. Now two consecutive elements—one black and one white, say—are equivalent to one electrical cycle, so 5,470,000 elements per second represents about 2.75 Mc/s. This derivation is very approximate, for some of the 405 lines are not used in tracing out the picture, and also it is usual for the horizontal definition to be rather greater than the vertical. Nevertheless, the nett result is that 3 Mc/s represents a generous upper limit to the British television bandwidth.

Synchronisation.

We have seen that for a satisfactory received picture, the spot of light that traces out the picture on the screen must be exactly in step with the scanning process in the camera. This is accomplished by introducing synchronising pulses into the electrical waveform generated by the camera. At the end of each scanning line a short pulse is transmitted which is used in the receiver to return the spot rapidly to the left-hand side of the screen and start tracing out the next line. At the end of the vertical traverse of the raster, a signal comprising several broader pulses is transmitted which causes the spot to fly back to the top of the screen and initiate the next vertical sweep. Fig. 4 shows in detail a typical video waveform with its synchronising pulses, and gives the pulse lengths employed in the British television system. It can be seen that these added pulses are all negative-going, i.e., their most positive point is at the voltage corresponding to black in the original picture; the pulses are therefore always in the region known as "blacker than black." The peak voltage of the synchronising pulses is constant and independent of the picture being scanned, but when the scene before the camera contains some pure white, the voltage in the camera waveform which corresponds to this—the "peak white voltage"—bears a ratio of 7:3 to the pulse voltage. The way in which these pulses are used to control the raster in the receiver will be described in a future article.

THE TELEVISION CAMERA

The preceding analysis of the requirements of a television system has gone a long way to specify the functions that the camera must perform. Broadly, they are two: it must scan the scene in the form of the standard raster; and it must instantaneously generate a voltage proportional to the brightness of the element of the scene being scanned.

The second of these camera properties can be achieved by employing the phenomenon of photoelectricity. Certain materials, such as selenium and caesium, have the property that they release electrons from their surfaces when light

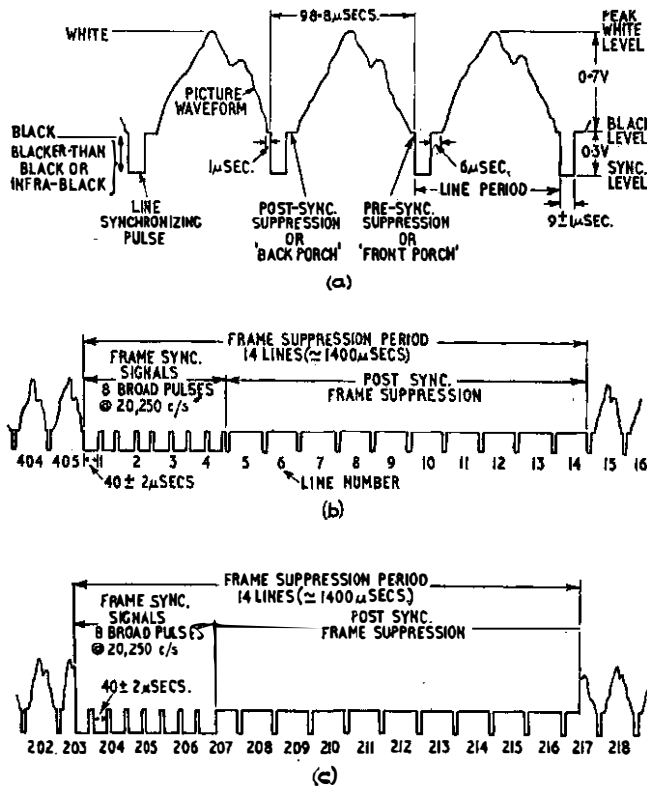

FIG. 4.—STANDARD BRITISH VIDEO WAVEFORM. (a) THE LINE VIDEO WAVEFORM, (b) SIGNAL AT END OF EVEN FRAMES, (c) SIGNAL AT END OF ODD FRAMES.

falls upon them. If these materials are arranged to be near an electrode of high positive potential in an evacuated container, this anode collects a small current from the photoelectric material that is nearly proportional to the brightness of the light falling upon it, and, what is more important, which varies almost instantaneously with the fluctuation of the light. This is, of course, the principle of the well-known photoelectric cell.

Clearly it would be impracticable to build a camera having a large number of photoelectric cells each focused on to a different point of the scene—nearly 200,000 would be needed for modern standards. The first practical electronic television camera avoided this problem by focusing the scene to be transmitted through an optical lens on to a flat plate (the "mosaic" or "image plate") which was effectively a sheet of insulating material such as mica on which a large number of tiny photoelectric cells had been deposited. An explanatory diagram of this type of camera (known as the "iconoscope") is given in Fig. 5(a). It can be seen that the mosaic is mounted in an evacuated tube, and that there is an electrode of positive potential nearby. The illuminated mosaic will release electrons from its surface according to the intensity of the light at any point, causing an electron image to be formed on the mosaic. The electrons emitted from the mosaic surface are collected by the electrode, but they leave behind a deficiency of charge on the mica plate that continues to build up the longer the light is allowed to fall upon it. The second requirement for a camera is thus fulfilled, for we now have an electrical equivalent to the visual scene; all that remains is for this electrical information to be extracted from the mosaic in a systematic way—in other words the electron image must be scanned.

The scanning is performed by an electron gun that projects a stream of electrons from a cathode obliquely on to the mosaic plate. This electron stream is accelerated to a high velocity, and at the same time deflected from side to side, and up and down to trace out a raster pattern on the

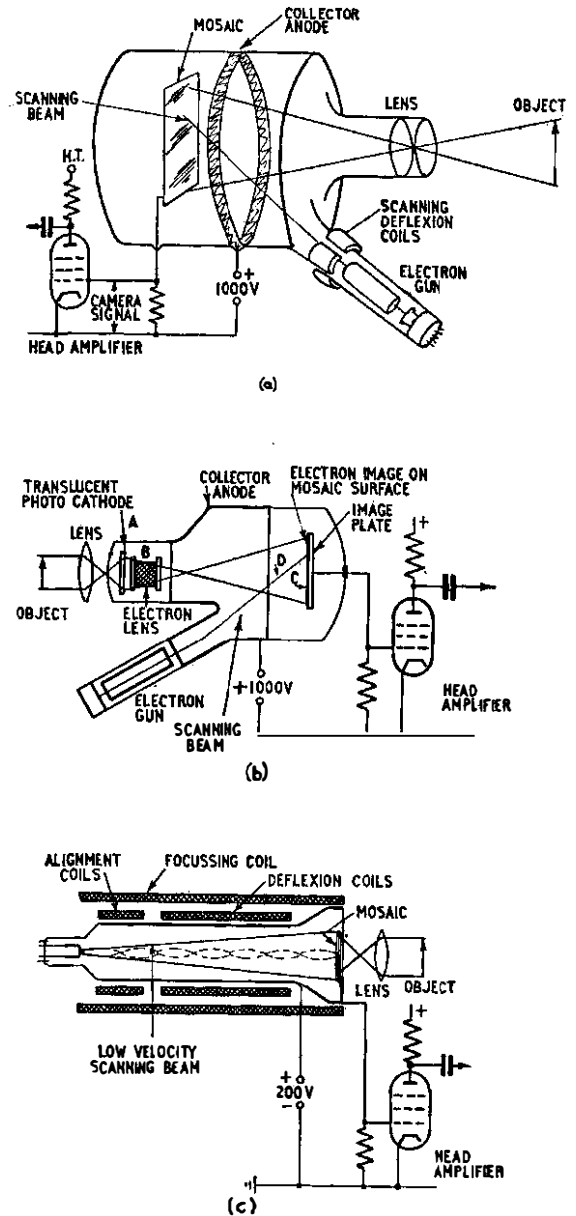

FIG. 5.—CAMERA TUBES. (a) ICONOSCOPE TUBE, (b) IMAGE ICONOSCOPE TUBE, (c) ORTHICON.

face of the mosaic. As the beam of electrons sweeps over the mosaic it discharges the tiny photoelectric cells in its path, and since these cells have been charged to different potentials by the different light intensities in the image, a series of discharge currents will flow into the graphite backing of the image plate. This plate therefore collects an electric current that varies with the intensity of light of the elements in the scene selected in a sequence determined by the scanning of the beam of electrons. This current from the camera is amplified by a "head amplifier" and is the basis for all subsequent operations; it is essentially this current variation that is transmitted, perhaps hundreds of miles, to produce the final picture on the screen of the home receiver.

A British version of the camera described above was used when Alexandra Palace started the first public high-definition service in 1936, and these cameras are still in active use. They have several disadvantages however: the tube is rather insensitive, requiring very bright scene illumination to give a satisfactory picture; uncontrolled secondary electrons are emitted from the mosaic surface and often cause spurious streaking and shading in the picture;

and the optical system and electron gun compete for space at the front of the camera and cause awkward mechanical design. A more sensitive version of this camera was developed, known as the image iconoscope, see Fig. 5(b), in which the photosensitive surface "A" is not scanned directly but is electrically focused by an electron lens "B" on to a second mosaic "C"—not photosensitive—which is rich in secondary electrons, and it is this second surface that is scanned by the electron beam "D." The effect of the secondary emission from the second plate is to multiply considerably the variation in charge in the electron image; the camera is, as a result, made about 10 times as sensitive as its more simple forerunner. Image iconoscopes of this type were first used in 1937 for outside-broadcast work where greater sensitivity is at a premium.

In modern British camera tubes the scanning is performed by a low-velocity stream of electrons impinging perpendicularly on to the mosaic which is sputtered on a transparent sheet of insulating material; the visual image is focused on to the other side of the mosaic plate. This type of tube is very sensitive, and no spurious signals cause shading over the picture; the generic title of such tubes is the "orthicon," and one is sketched in Fig. 5(c).

The camera tube, together with an amplifier to boost the weak signal received from the mosaic, is fitted on to a sturdy mounting, which may either be fixed in position or in the form of a movable trolley or crane. The cameraman can direct the camera at the centre of interest, alter the focus of the lens, adjust the iris, and, in modern cameras, select a particular lens from a multi-lens turret. He is provided with a viewfinder that may be either a purely optical device or a miniature television set working from the camera that he himself is operating; the optical type shows a greater area of scene than in fact the camera transmits. Using this, the cameraman can see if anything interesting is happening outside the active field of transmission (which is marked out as a rectangle on the viewfinder screen), and can so control his camera movements to allow for probable future occurrences.

Some modern cameras can be completely operated by remote control: their movements, the focus, aperture, and selection of lens, are all controlled from a remote viewpoint to which the viewfinder is extended. These cameras are particularly valuable where space is restricted.

PICTURE CHANNEL EQUIPMENT

Although the camera signal is the fundamental basis of any television system it is not sufficient in itself, for it is also necessary for the signal to contain regularly recurring pulses that will trigger both the horizontal and vertical scanning in the receiver. Such pulses are produced by a synchronising signal generator which will probably serve all the cameras in the studio. Besides being incorporated into the video waveform, these pulses are also used to initiate the deflecting voltages that sweep the electron beam across the face of the camera mosaic. To give the required scanning action the deflection current waveforms must be in the form of sawtooth waves, which are applied to the pairs of magnetic deflecting coils fitted perpendicularly to each other around the electron gun; the sawtooth waveforms should have a frequency of 10-125 kc/s for the horizontal deflection and 50 c/s for the vertical. A block schematic diagram of a typical arrangement is given in Fig. 6. During the brief periods ("line flyback" periods) in which the scanning electron beam is retracing its path from the right-hand edge to the left in preparation for the next scanning sweep, the camera generates a spurious signal representing the picture in reverse; and during the longer period (the "frame suppression" period) in which the trace returns from the bottom to the top of the mosaic, there will be further spurious signals. These unwanted voltages are removed by a blanking wave-

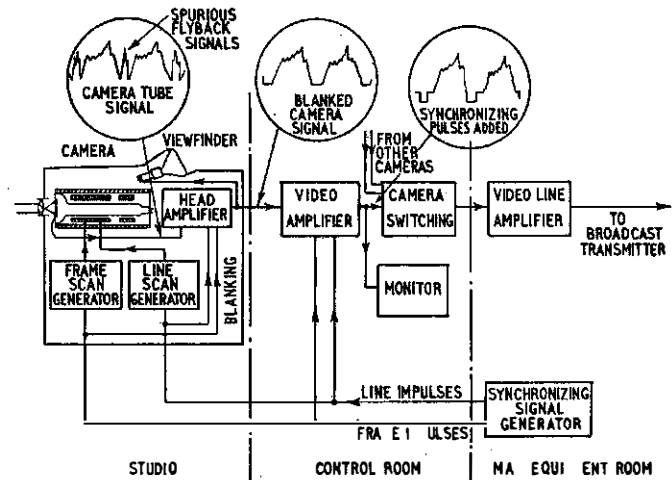

FIG. 6.—BLOCK SCHEMATIC DIAGRAM OF CAMERA AND CONTROL ROOM.

form that completely blots out the camera signal during these flyback periods, and it is in these "blacked out" periods of the camera waveform that the frame and line synchronising pulses are inserted. From this it can be seen that the initiation of every line and frame scan in the camera, the blanking out of unrequired signals, and the introduction of the synchronising pulses into the video waveform, all depend on the synchronising pulse generator. The latter equipment sometimes provides, in addition, electronically-generated patterns which, in the absence of a camera picture, may be used for testing television equipment and transmission systems. The black cross on a white ground which can sometimes be seen before or after the main programme transmission is generated in this way.

Mention has been made of the fact that several cameras are normally fed from the same synchronising pulse generator. This not only makes the duplication of expensive equipment unnecessary, but also ensures that all the cameras working together in one unit shall be in synchronism.

For outside broadcasts the B.B.C. have several large vans, called "mobile control rooms." These normally contain three operating cameras, which may be moved as much as 1,000 ft. from the parent van, and a central synchronising pulse generator that transmits the deflection voltages along cables to the distant cameras, and mixes blanking and synchronising signals into the video waveform. It is only in exceptional cases, such as a camera mounted on a launch or in aircraft, that a single camera is provided with its own synchronising pulse generator, although there is a modern tendency towards cameras containing their own scanning waveform generators with only driving pulses supplied by cable. This applies to studio systems as well as outside broadcasts.

STUDIO EQUIPMENT AND PROCEDURE

Besides the live transmissions originating from the studios and outside-broadcast sites, an appreciable part of the programme material in the B.B.C. service is derived from films. A programme may be devoted entirely to film transmission, or a brief shot of filmed action may be introduced into a live production to represent scenes which would be difficult to stage in the studio. The equipment that produces a standard television waveform from a motion picture is known as a film scanner, and the type used at present by the B.B.C. employs a continuous-motion flying-spot system, which probably gives a higher quality picture than any other type of picture generation. In this form of scanner the film passes through a projector mechanism which pulls the film through continuously at

25 frames per second, instead of the normal cinematic arrangement of an intermittent drive at 24 frames per second. The film is scanned by a sharply-focused raster projected from a cathode-ray tube through the film on to a photoelectric cell; this raster has the proportions of 4:1½, but this is effectively expanded by the vertical movement of the film to the normal 4:3 aspect ratio. A complex arrangement of lenses and shutters ensures that the electrical output from the photo-cell possesses the interlaced scanning properties of a normal camera output. In another system a continuous and stationary optical image is projected from the film on to the mosaic of a camera, and is scanned in the normal way.

A further useful piece of equipment is the telefilm recorder, which performs the reverse function of the film scanner in that it makes a film record on normal 35-mm. stock of any television programme. This device is essentially a cinema camera focused on to a high-quality television picture monitor, with special arrangements to make the television frame period correspond precisely with that of the film.

The sound and music associated with the programmes are picked up by microphones and can be recorded and transmitted in just the same way as in normal sound broadcasting, with this difference: the microphones must often be mounted on movable booms (as in film studio technique) to keep them, and their shadows, out of the cameras' vision.

The studio is overlooked by a control room in which picture monitors display the scene viewed by all the cameras in use, and in which the producer controls the course of the programme: he it is who selects which of the camera outputs he prefers at any instant; who directs the cameramen by a microphone and headphone system as to what should be their future course of action; who can introduce a film sequence at will; and who can mix, fade or intercut any of the picture sources that he governs; and it is the video waveform representing the result of his operations that must be transmitted over the country to reproduce the programme on the screens of thousands of domestic receivers.

(To be continued)

Book Reviews

"Data and Circuits of Radio Receiver and Amplifier Valves." N. S. Markus and J. Otte. Book IIIA in the Philips Technical Library Series of Books on Electronic Valves. Distributed by Cleaver-Hume Press, Ltd., London. 500 pp. 505 ill. 40s.

This book contains descriptions and data relating to the receiving and amplifying valves developed in the Philips organisation during the period 1945-1950; it is a sequel to Books II and III which covered the periods 1933-1939 and 1940-1941 respectively. Although the book is essentially a collection of valve data, and is thus of less interest to the general reader than other volumes in this series, it also contains some useful information on the applications of the valves described to radio receivers.

W. J. B.

"Transmitting Valves." J. P. Heyboer and P. Zijlstra. Book VII in the Philips' Technical Library Series of Books on Electronic Valves. Distributed by Cleaver-Hume Press, Ltd., London. 284 pp. 256 ill. 35s.

This book forms part of the "Philips' Technical Library" and is a translation of the original Dutch version. The main title of the book, "Transmitting Valves," is descriptive of the subject matter, but little attention has been given to the types of transmitting valves designed for use in conjunction with co-axial lines, for example disc-seal valves. The treatment of the use of "classical" types of transmitting valves is satisfactory and not overburdened with mathematics, but is not without a few unusual words and phrases. From the sub-title, "the Use of Pentodes, Tetrodes and Triodes in Transmitter Circuits," and the foreword, not by the authors, the reader may well expect at least a short note on "high efficiency" operation, the use of grounded-grid techniques and perhaps the employment of quarter-wave line intervalve coupling networks; but the text is confined to grounded-cathode operation and anode loads that comprise a resistance-damped parallel-tuned network. These omissions are a little surprising when it is considered that more than six pages are used to demonstrate the accuracy of "Simpson's Rule."

This book should be very useful to students and engineers who are interested in the employment of valves under conditions when high anode efficiencies are required.

F. G. C.

"Application of the Electronic Valve in Radio Receivers and Amplifiers," Vol. 2. B. G. Dammers, J. Haantjes, J. Otte and H. Van Suchtelen; Book V in the Philips Technical Library Series of Books on Electronic Valves. Distributed by Cleaver-Hume Press, Ltd., London. 450 pp. 343 ill. 45s.

This is the second of three volumes devoted to the application of valves in radio receivers and amplifiers; the first volume dealt with radio and intermediate frequency circuits, frequency changing and detection. The present volume deals with audio frequency amplification, the output stage and the power supply.

The section on audio frequency amplification includes detailed discussions of the basic a.f. circuits, phase-inverters, the frequency/response characteristics of a.f. stages, the design of a.f. transformers and an excellent treatment of non-linear distortion.

The section on output stages deals with class A, push-pull class B and class AB stages, compares the characteristics of triodes and pentodes and discusses the distortion present in such stages. The chapter dealing with the dynamic characteristics of output stages includes some interesting oscilloscope patterns depicting the influence of the load impedance and the driving signal on the load line.

The final section of the book is concerned with the design and characteristics of power supply units; it includes chapters on the provision of heater supplies, single-phase and multi-phase rectifier circuits, smoothing circuits and circuits for stabilising the H.T. supply voltage.

The treatment of the subject is, as in the case of the preceding volume, very thorough and detailed; it includes a well-balanced development of the theoretical aspects in addition to a wealth of measured data. The measured data has certain limitations since it relates primarily to valves developed in the Philips Laboratories and does not include certain interesting types of valve developed elsewhere; nevertheless, it is of great value in illustrating and giving point to the theoretical discussions. The bibliography given at the end of each chapter is drawn mainly from the European literature on the subject; this is a refreshing change from many text-books in this field which tend to refer, perhaps excessively, to American sources.

There is no doubt that this volume, and its predecessor, will form authoritative reference books on the subject for many years to come.

I.P.O.E.E. Library No. 2031.

W. J. B.

The Effect of Temperature on the Transmission Characteristics of Carrier Cable

C. E. PALMER-JONES and
I. F. MACDIARMID, A.M.I.E.E.†

U.D.C. 621.317.341: 537.312.6: 621.395.44

To permit the design of temperature equalisers for 24-circuit carrier systems, the variation of carrier cable attenuation with temperature has been determined, under laboratory conditions, between 0°C and 20°C in the frequency range of 1 to 120 kc/s for the side circuits (carrier) and 0.1 to 20 kc/s for the phantom circuits (music). This article describes the measuring techniques employed and includes a discussion of the results and comparisons with those obtained elsewhere.

INTRODUCTION

EXPERIENCE with long 12-circuit carrier cables has shown that their overall loss is subject to large variations which are not the same at all frequencies. Apart from faults, one known cause of the variations is that a change in the attenuation coefficient of the cable results from a change in temperature. Further, the shape of the attenuation/frequency characteristic curve also changes with temperature. It is proposed to correct for this variation by means of "temperature equalisers" whose use on 24-circuit routes has already been mentioned in this Journal.¹ Before such equalisers could be designed, it was necessary to know the change in attenuation coefficient for the practical range of temperature (0° to 20°C) of buried cables in this country. A precision corresponding to 0.5 db. or better on a 200-mile circuit was considered necessary. In the frequency range of the music circuits, which use the phantoms on the carrier cable pairs, this precision does not present any great difficulty. However, in the 24-channel range the total cable loss is 750 db. at the highest frequency, and hence the required accuracy of measurement is 1 part in 1,500 at this end of the range.

The effect of temperature on conductor resistance is well known, and this alone would cause the attenuation coefficient of a cable to alter by different amounts at different frequencies. However, the other primary parameters (L , C and G) of a cable are also affected by changes of temperature in a somewhat unpredictable manner; consequently, the net change of overall loss cannot be predicted. Therefore, a programme of measurements on samples of 24-pair, 40-lb. carrier cable was undertaken to determine the magnitude of the effects and the differences between the products of different manufacturers.

MEASUREMENT OF ATTENUATION

To ensure uniformity of results and reliable knowledge of cable temperatures, measurements were made under controlled conditions in a laboratory. This implied that the test lengths were necessarily quite short—actually one drum length.

Attenuation was determined by calculation from measured values of open and closed impedance in preference to direct methods, for three reasons. First, with specimens of restricted length it was believed that a high degree of accuracy could only be achieved in this way. Second, it is possible to analyse the contributions to the variation of attenuation coefficient due to temperature change into the separate effects on each of the primary parameters. Third, all the transmission coefficients can be deduced with accuracy and without need to refer to the specimen again if new interests should arise later, e.g. in velocity characteristics.

General Arrangement of Measurement Work.

The basis adopted for the investigation was the measurement of the attenuation/frequency characteristics of the cable specimen at the two limiting temperature values,

†The authors are, respectively, Senior Executive Engineer, London Telecomms. Region (formerly at P.● Research Station), and Executive Engineer, P.O. Research Station.

0° and 20°C. A preliminary test proved that while the effects are non-linear over a wide range of temperature, a substantially linear relationship exists over the stated range. It is therefore possible to express the results as attenuation change per degree Centigrade at each frequency. Results will not agree, however, with those obtained by other workers who have heated the cable to temperatures outside this range.

An A.C. impedance bridge was used to measure the impedance of open-circuited and short-circuited pairs (or phantoms) in each cable tested, in each temperature condition and at each of a number of frequencies.

While measurements were carried out, the cable specimen—about 176 yards of cable, P.C.Q. Carrier, 24-pair, 40-lb—was kept on its drum. The whole drum was immersed in a large vessel of water whose temperature was closely controlled to 0°C or to 20°C. Control of temperature was by electrical immersion heaters, or by the addition of ice as required. The heat inertia of the water bath was very convenient as the range of temperature to be used was small; air heating and cooling would have been far less satisfactory. The water in the vessel was circulated during all the tests by means of a pump.

The end of the cable, remote from the bridge, was sealed after looping back the pairs as required. At the bridge measuring end, it was not necessary to lead out all the pairs separately, but a system of connections was required to enable sets of pairs to be connected together to give suitable lengths for measurement; this aspect is treated in the following paragraph. The end of the sheath was sweated on to a cone made from sheet lead. The open end of the cone was covered by a disc of sheet lead through which the required number of leading-out wires were brought via silvered ceramic hermetic seals. During the cold tests, warm air was blown on the seals to prevent the condensation of moisture on their surfaces.

Length of Circuit for Test.

While it is desirable that the circuit tested should be as long as possible, it is preferable to avoid using a length equivalent to a quarter-wavelength at any test frequency. Since the range of frequencies concerned was so wide, observance of this requirement would have caused appreciable loss of accuracy at the low frequencies by keeping the specimen short enough for the higher frequencies. As a compromise, a single quarter-wavelength point was allowed to fall within the band at about 80 kc/s, and this part of the range was separately explored with a shorter specimen. This requirement permitted the connection of four pairs in tandem, when testing up to 120 kc/s. When testing the phantom circuits, the frequency range of interest stopped at 20 kc/s and all 12 quads could be joined in tandem for the test. The appropriate proportion in each looped set of pairs is three outer-layer pairs to one inner-layer pair, which represents the normal ratio found in practice on long circuits as a result of systematic jointing.

A.C. Impedance Measurements.

Like the specimen, the bridge circuit used is balanced with respect to earth. This is to reduce errors due to stray admittances and to crosstalk couplings between the pairs

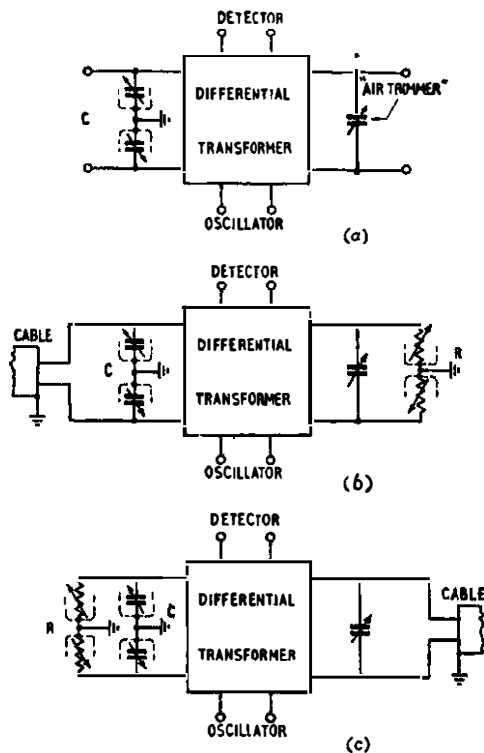

FIG. 1.—IMPEDANCE BRIDGE FOR BALANCED CABLES; (a) INITIAL BALANCE; (b) CABLE IMPEDANCE POSITIVE; (c) CABLE IMPEDANCE NEGATIVE.

which are connected back and forth in the specimen of cable.

A unity-ratio differential transformer with balanced windings forms the appropriate bridge for the present purpose (see Fig. 1.) The adjustable resistance and capacitance "standards" must also be balanced, and the artifice of using two unbalanced components back to back was utilised. When the impedance angle changes sign from the previous measurement made, the cable and the resistor connections are interchanged, thus leaving the residual admittances of the circuit unaffected; see Fig. 1(b) and (c).

The leads were kept very short and as unvarying in position as possible. An 8-in. twisted-pair lead connected the specimen to the bridge.

The accuracy and constancy of the testing frequency were monitored continuously by means of Lissajou's figure displays on a cathode-ray oscilloscope. A sensitive amplifier-detector was assisted in discriminating against harmonics of the testing frequency (present in the output of the oscillator) by means of a filter.

Errors in calibration of the resistance "standard" and the resetting errors due to change of contact resistance come into significance in this work because of the unusually high degree of precision necessary. To eliminate them, a high-grade D.C. bridge was used to measure the actual resistance after every observation. At some frequencies the bridge resistance "standard" included a carbon resistor put into circuit to build out to the high value required.

The balance components encountered in working between 20 and 120 kc/s lay between the limits shown in Table 1.

The precision required in this investigation made it necessary to examine critically all sources of error in the measurements, and to make appropriate adjustments in

TABLE 1

	Capacitance	Resistance
Impedance with positive angle ..	200 $\mu\mu\text{F}$ to 0.15 μF	20 to 1,000 ohms
Impedance with negative angle ..	200 $\mu\mu\text{F}$ to 0.06 μF	20 to 10,000 ohms

procedure or in calculation for sources large enough to be of consequence (see Appendix). The limit of permissible error in impedance components is considered to be 0.1 per cent. This cannot be directly related to the maximum tolerable error of 0.06 per cent. in the attenuation coefficient, but experience suggests that this value is safe.

DETERMINATION OF TEMPERATURE

The care taken to ensure accurate determination of attenuation has been referred to in the foregoing section; the lengths of the specimens were directly measured by a steel tape, after careful temporary straightening. There remains the most difficult item in which to obtain the required degree of accuracy, viz., the estimation of the temperature of the specimen at any time during testing.

At the steepest part of the curves connecting attenuation coefficient and temperature, a difference in temperature of 0.45°C corresponds to 0.5 db. change of attenuation in 200 miles, i.e., 0.0025db. per mile. The thermometers available were capable of reliable readings to one-tenth of 1°C.

Measuring the D.C. resistance of a cable pair offers the only reliable method of discovering the average temperature throughout the cable specimen. However, the relationship between the D.C. resistance and the actual temperature has to be established for each cable *in situ*, because handling may affect the absolute resistance as well as the temperature coefficient of D.C. resistance of the conductors. This coefficient and the resistance at one known temperature are determined by test, associating the averages of a large number of resistance and temperature readings, after all possible precautions have been taken to ensure the thermal stability of the system. The actual temperature of the cable at each impedance measurement is then found from the D.C. resistance of the pair thus calibrated. This "actual" temperature is never in practice exactly 0°C or 20°C; there is always a small margin due to the practical limitations of holding a large mass to a temperature not far different from the ambient conditions. Allowance is made for this margin before correlating the results, by correcting the attenuation values by calculation to correspond to precisely 0°C or 20°C, as appropriate.

Discussion and Comparison of Results.

The data on D.C. resistance and low-frequency capacitance for the four makers' cables which have been tested are summarised in Table 2.

TABLE 2
Summarised Details of Cable Samples Tested

Manufacturer Date of Manufacture	A 1945	B 1943	C 1945	D 1945
D.C. resistance, average for 12 pairs (ohms/mi e)	0°C 40.52 20°C 43.97	40.50 43.96	39.93 43.37	30.67 43.07
Length of side circuit tested (miles)	0.3980	0.3637	0.4106	0.4042
Pairs tested (side circuit) ..	1, 3, 5, 7	6, 8, 10, 12	6, 8, 10, 12	8, 10, 12, 14
Temperature coefficient of D.C. resistance (average for 12 pairs)	0.00426	0.00427	0.00430	0.00429
Effective resistance at 1 kc/s. average for 4 pairs (ohms/mi e)	0°C 40.59 20°C 44.02	40.62 44.00	40.15 43.55	39.88 43.29
Capacitance at 1 kc/s., average for 4 pairs ($\mu\text{F}/\text{mile}$)	0°C 0.0557 20°C 0.0563	0.0547 0.0553	0.0543 0.0549	0.0574 0.0582
D.C. resistance of phantom, average for whole cable (ohms/mile)	0°C 20.26 20°C 21.98	20.24 21.97	19.98 21.70	19.83 21.54

Typical curves of the differential coefficient of attenuation with respect to temperature versus frequency

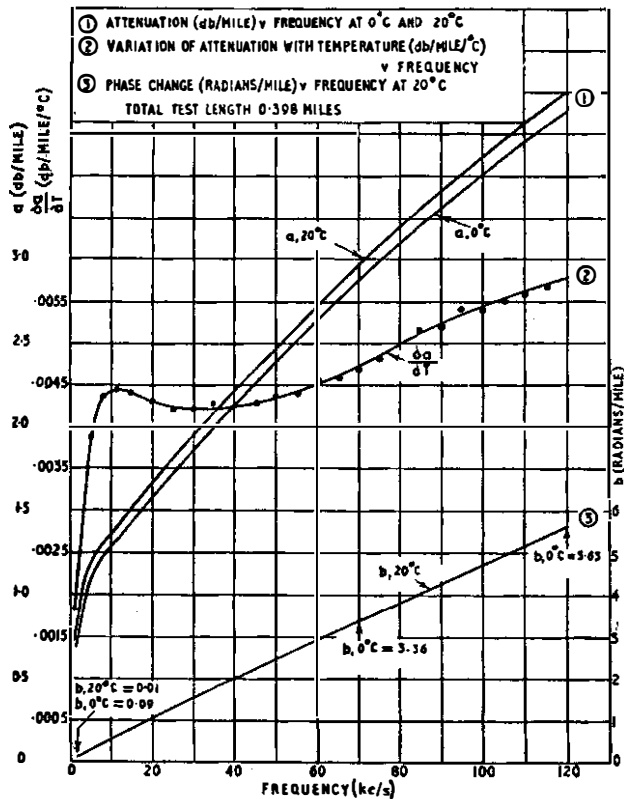

FIG. 2.—SIDE CIRCUIT ATTENUATION, PHASE CHANGE AND DIFFERENTIAL COEFFICIENT OF ATTENUATION WITH RESPECT TO TEMPERATURE *v.* FREQUENCY.

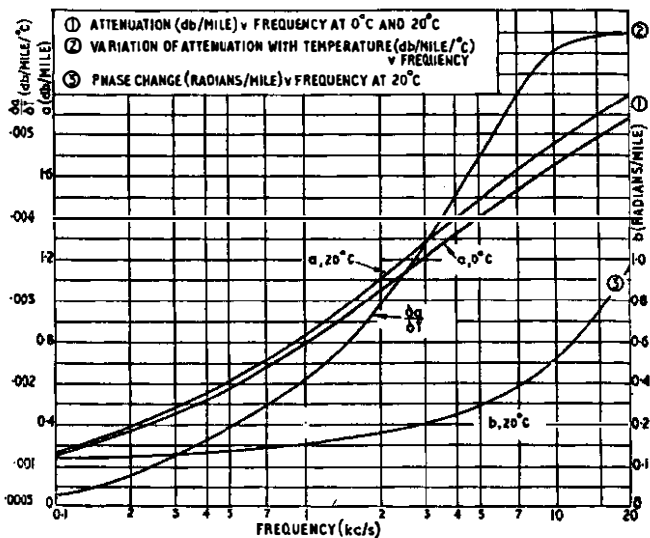

FIG. 3.—PHANTOM CIRCUIT ATTENUATION, PHASE CHANGE AND DIFFERENTIAL COEFFICIENT OF ATTENUATION WITH RESPECT TO TEMPERATURE *v.* FREQUENCY.

are shown in Figs. 2 and 3, respectively, for side and phantom circuits. In Fig. 4, another differential coefficient is plotted against frequency, viz., that of attenuation with respect to D.C. resistance. This is more directly related to field observations, where the only clue to the temperature of the conductors is their resistance.

The separate effects due to temperature upon the individual primary parameters of the same sample as used in Fig. 2 are illustrated in Figs. 5, 6 and 7, and the effect upon impedance is shown in Fig. 8.

Examination of the individual points plotted to give the various curves shows a maximum scatter of 0.0001 db./mile/°C, in the vicinity of quarter-wavelength effects,

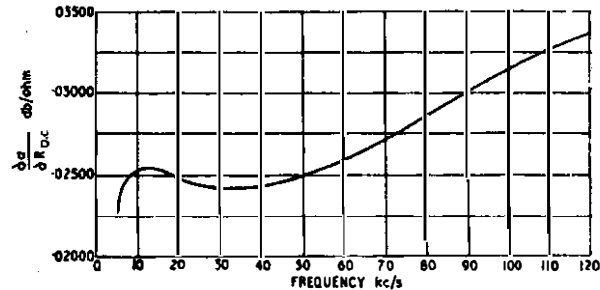

FIG. 4.—DIFFERENTIAL COEFFICIENT OF ATTENUATION WITH RESPECT TO D.C. RESISTANCE *v.* FREQUENCY.

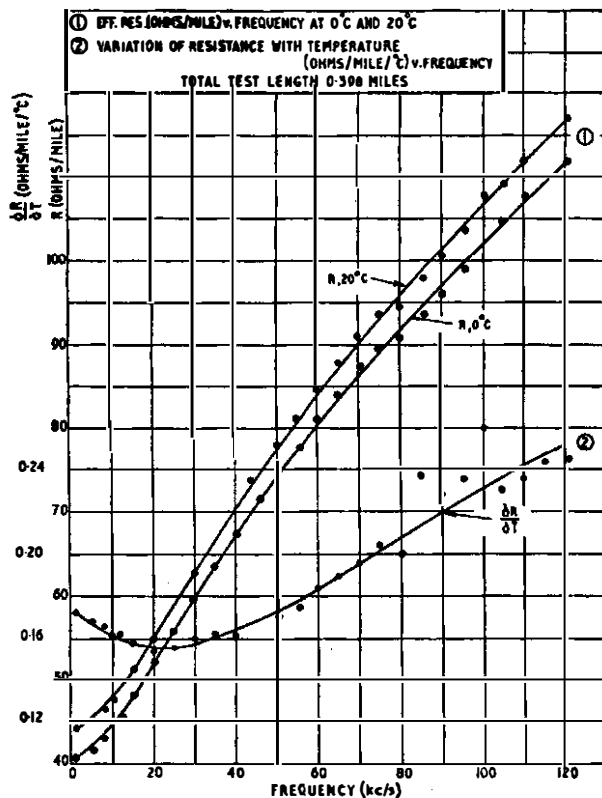

FIG. 5.—SIDE CIRCUIT EFFECTIVE RESISTANCE AND DIFFERENTIAL COEFFICIENT OF RESISTANCE WITH RESPECT TO TEMPERATURE *v.* FREQUENCY.

and very much better at other frequencies. This is evidence of the efficacy of the precautions taken against random and observational errors in the measurements.

The spread of the curves as between cables from different manufacturers is not greater than ± 0.00015 db./mile/°C at any frequency, and as this is so small, the original intention to explore manufacturing differences was abandoned.

Examination of $\frac{\partial a}{\partial T}$ versus Frequency Curve.

An attempt has been made to determine the cause of the curious dip in the $\frac{\partial a}{\partial T}$ versus frequency characteristic (Fig. 2) between 30 and 50 kc/s. The first step is the splitting up, by partial differentiation (equation 13 of reference 2), of the total $\frac{\partial a}{\partial T}$ characteristic into the parts produced by the separate variations of the four primary parameters. The result of this is shown in Fig. 9, which indicates that it is the resistance variation which is mainly responsible for the dip. Next, the expression for the part of $\frac{\partial a}{\partial T}$ due to the resistance variation is compared with a known expression for the attenuation,³ viz.:

$$a = \frac{R}{2R_0} + \frac{G}{2G_0}$$

where R_0 and G_0 are the real parts of the characteristic

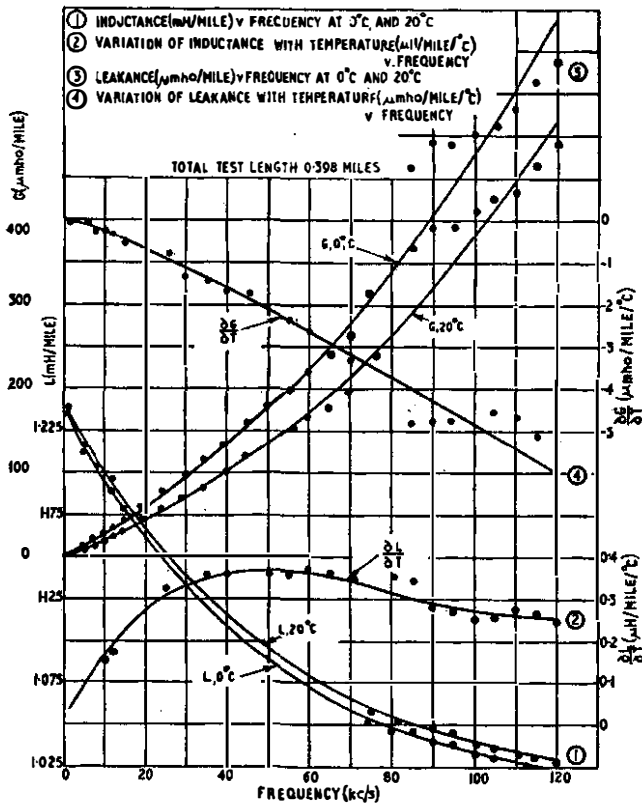

FIG. 6.—SIDE CIRCUIT INDUCTANCE, LEAKANCE AND DIFFERENTIAL COEFFICIENTS OF INDUCTANCE AND LEAKANCE WITH RESPECT TO TEMPERATURE *v.* FREQUENCY.

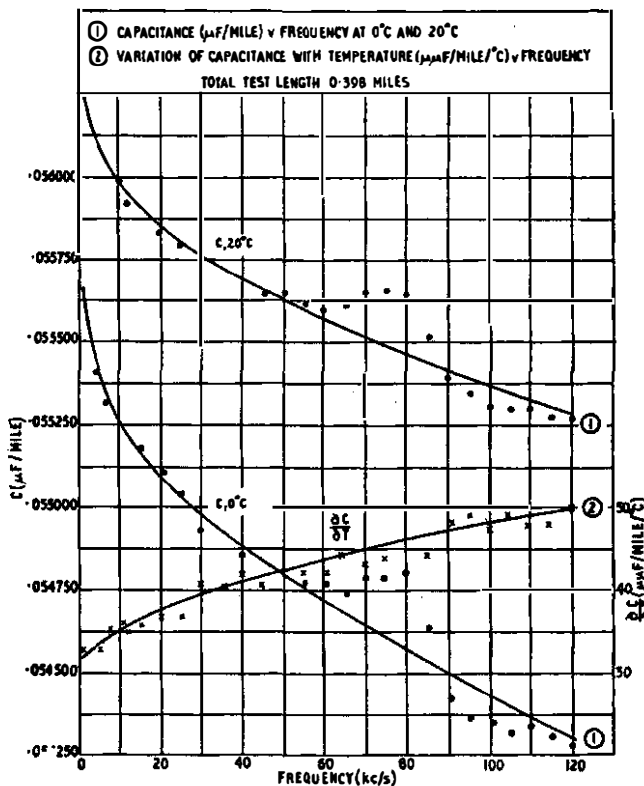

FIG. 7.—SIDE CIRCUIT CAPACITANCE AND DIFFERENTIAL COEFFICIENT OF CAPACITANCE WITH RESPECT TO TEMPERATURE *v.* FREQUENCY.

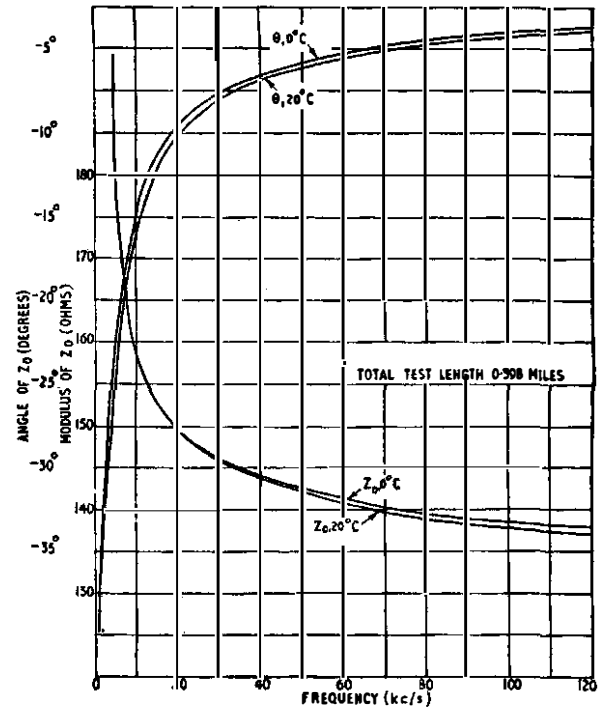

FIG. 8.—SIDE CIRCUIT CHARACTERISTIC IMPEDANCE *v.* FREQUENCY.

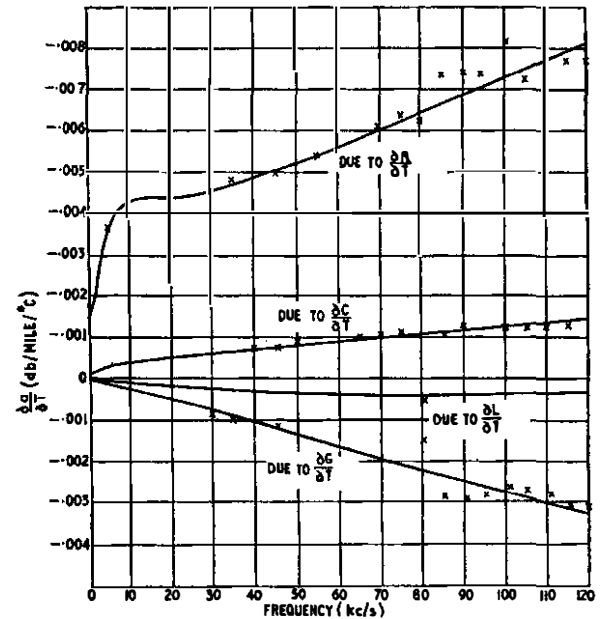

FIG. 9.—VARIATION OF ATTENUATION WITH TEMPERATURE DUE TO VARIATION OF PRIMARY PARAMETERS (FROM MEASUREMENTS AT 0° AND 20°C ON A LENGTH OF 0.398 MILES).

impedance and admittance respectively. From this it can be shown that the part of $\partial a/\partial T$ due to resistance variation with temperature is $\frac{G_0}{2} \cdot \frac{\partial R}{\partial T}$ (nepers/mile/°C). The terms in this expression are plotted separately in Fig. 10, where it is seen that G_0 behaves in the expected manner being asymptotic to $\sqrt{\frac{C}{L}}$ at high frequencies.

The correctness of the shape of the $\partial R/\partial T$ curve is obvious as it depends on the skin effect which, for the purpose of the frequency range of greatest interest, is in the process of establishing itself and consequently its effects can be assessed by simple approximate calculations.

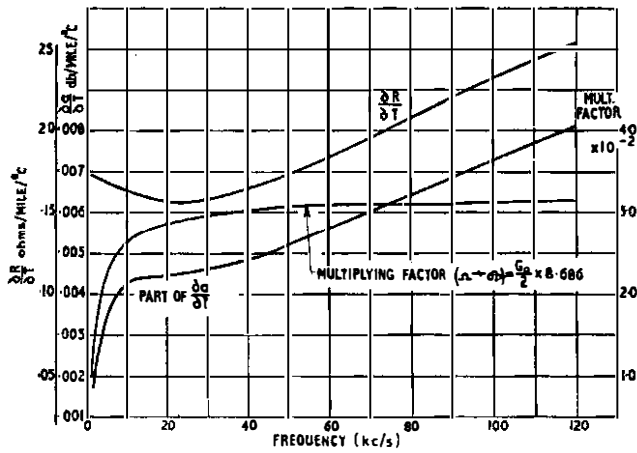

FIG. 10.—COMPOSITION OF COMPONENT OF $\frac{da}{dT}$ DUE TO VARIATION OF RESISTANCE WITH TEMPERATURE SHOWN IN FIG. 9.

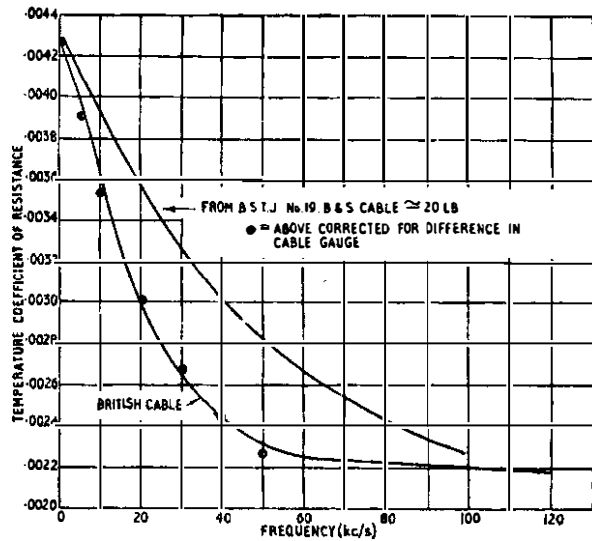

FIG. 11.—TEMPERATURE COEFFICIENT OF RESISTANCE *v.* FREQUENCY; COMPARISON OF MEASURED VALUE WITH DATA FROM *B.S.T.J.*, JULY 1941, pp. 299 AND 301.

However, a published curve exists² for the temperature coefficient of resistance $\left[\frac{1}{R} \cdot \frac{\partial R}{\partial T} \right]$ of an American cable over the frequency band under consideration. This is reproduced in Fig. 11, along with the curve for one of the British cables. When a correction for the difference in conductor gauge is applied to the American figures it is seen that good agreement exists.

Laboratory and Theoretical Comparisons.

The earliest known approach to the subject is a curve sheet prepared by Siemen Bros. in 1938. This is believed to have been obtained by calculating the effect of temperature on R , measuring its effect on C and G , using a short length and neglecting its effect on L . This curve has substantially the same shape as a corresponding curve from the present investigation, but is displaced appreciably from it in amplitude at frequencies greater than 5 kc/s. This cannot readily be accounted for with the data available.

The only other laboratory measurements on British cable, of which the authors are aware, are unsuitable for comparison as they were taken in a higher temperature range than the practical one.

The work published⁴ in Japan shows comparable trends up to their frequency limit of 30 kc/s. Although they

recognised the non-linearity of the effects over the temperature scale, they chose the temperature range 0°C-50°C; they also recognised the differences between inner and outer layers and the tendency for the curve to fall off above 30 kc/s.

The Bell Laboratories' published data² of 1941 refers mainly to a cable of No. 19 B & S gauge conductors (approx. 20 lb.) having markedly different primary parameters from British carrier cable. The parameters show general trends similar to those of British cable in respect of the variation with frequency of their temperature coefficients and the correspondence of the resistance characteristic has already been discussed. Their overall effect on attenuation is somewhat different.

One curve of temperature coefficient of attenuation is, however, given for No. 16 B & S gauge cable (approx. 40 lb.) in Fig. 16 of reference (2). The agreement between this and a similar curve from the present work is very good.

The French Administration's cables also appear to differ in characteristics from the British to an extent precluding detailed comparison. The paper⁵ of 1947 on this subject, published while the G.P.O. work was still in progress, is mainly of a theoretical nature.

Field Work Comparison.

Two corroborative field tests were begun on British carrier cables *in situ*. One of these (unfortunately the more elaborate) was spoiled after many months of detailed work, by the discovery that bomb damage had led to an emergency repair which invalidated the results; this was unknown due to war-damaged records. The other field work consisted of loop attenuation measurements on two cables (LV-MR, 220 miles, LS-HU, 280 miles) carried out by the Transmission and Main Lines Branch of the E.-in-C.'s office. The weaknesses of this confirmation are that the repeaters and equalisers, with their variations, are included and that broad assumptions have to be made as to the actual average temperatures. The agreement on the shape of the $\frac{da}{dT}$ curve plotted against frequency is good, but shows a general displacement, probably accounted for by the assumptions mentioned. The average temperature seems to be some 4 or 5 degrees in error, and this is hardly surprising, as it was related to Meteorological records of ground temperature via an assumed temperature coefficient of resistance of a conductor. The LV-MR field measurements, after having been corrected for this supposed temperature error, are shown with the corresponding laboratory measurements in Fig. 12. Similar curves result from the LS-HU tests.

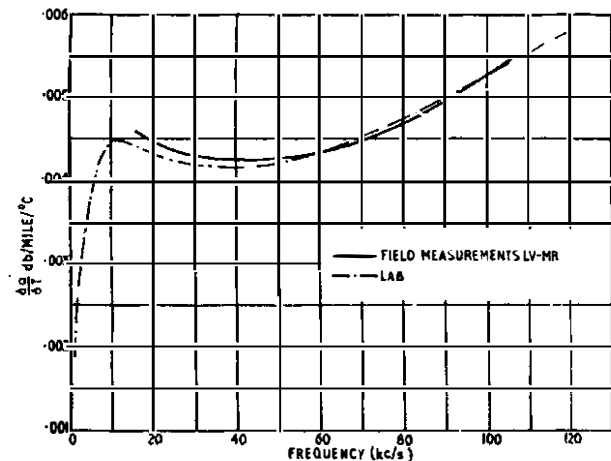

FIG. 12.—COMPARISON OF RESULTS OF FIELD AND LABORATORY MEASUREMENTS OF VARIATION OF ATTENUATION WITH TEMPERATURE, FOR SIDE CIRCUITS.

CONCLUSION AND ACKNOWLEDGMENT

The results in the form of curves of the type shown in Figs. 2 and 3 provide the data necessary for the design of temperature equalisers, both for 24-circuit carrier systems using the side circuits and for music circuits using the phantoms. The accuracy of the results is believed to be at least that aimed at, viz. sufficient to ensure an error not greater than 0.5 db. in a 200-mile circuit.

Much work remains to be done on the measurement of the temperature of cables *in situ* to complete the study of this aspect of cable utilisation. It may become increasingly necessary to acquire reliable information as higher frequencies are exploited. Using thermistors inserted by trepanning into a cable which is then repaired by the unidiameter process, a series of very sensitive thermometers can be permanently installed at as many intervals along the length of the cable as desired, up to the limit set by the number of conductors. The effects of a variety of circumstances upon the temperature could be readily determined as well as the still unknown effect of pulling-in stresses upon the conductor temperature coefficient of resistance.

The authors wish to acknowledge and thank the many of their colleagues who have helped in the work described in this article by contributions either to the principles or the hard work necessary to achieve the results; particular mention must be made of the contributions of J. G. Anderson and M. B. Williams.

APPENDIX

The measurement errors investigated during the course of this work are given in Table 1.

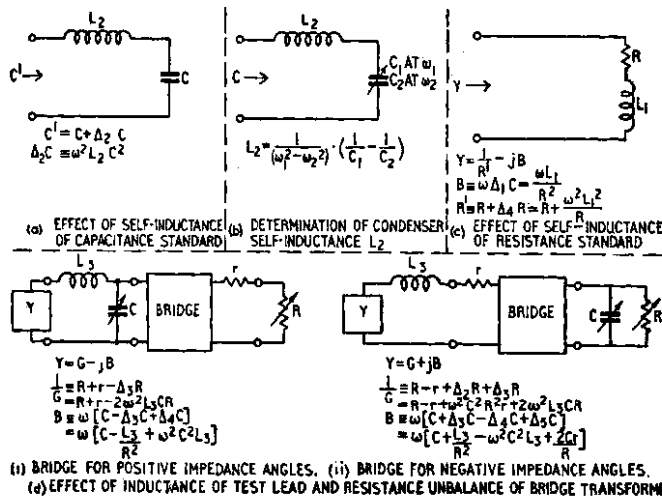

FIG. 1.—CORRECTIONS FOR RESIDUALS IN STANDARDS AND IN BRIDGE.

TABLE 1

Nature of Source of Error	Extent of Error	Steps to Eliminate Effect
(a) REACTANCE ERRORS:—		
1. Stray capacitances ..	Considerable	Use of method of initial balance and difference. Allow for capacitance of test leads.
2. Power factor of capacitors ..	Negligible	
3. Inductance of capacitors and wiring ..	Moderate	Allowed for by correction in calculation [Fig. 1(a) and (b)].
4. Reactance in resistors and wiring ..	Considerable	Ditto [Fig. 1(c)].
5. Due to bridge transformer residual unbalances ..	Poling shows ratio inequality negligible but res. unbal. of 0.1 ohm	Joint correction of the reactance component is applied to account for both these errors at the calculation stage. The correction differs according to sign of reactance [Fig. 1(d)].
6. Effect of inductance in test leads ..	Noticeable	
(b) RESISTANCE ERRORS:—		
1. Reactance of resistors and wiring ..	Negligible except near λ/4 freq.	Correction in calculation when error is appreciable [Fig. 1(c)].
2. Change of resistance due to h.f. skin and proximity effects ..	Small in freq. range used (<0.1 Ω)	Tabulated for correction in calculation.
3. Due to bridge transformer residual unbalances ..	See above (a) 5	Joint correction of the resistance component is applied to account for both these errors at the calculation stage. The correction differs according to sign of the reactance [Fig. 1(d)].
4. Effect of inductance in test leads ..	Noticeable	

A systematic method of applying the necessary corrections has been evolved, including an algebraic convention of signs to permit addition of the several corrections. Networks simulating the extremes of impedance values encountered were made up to verify the correction procedures.

References.

- "The Conversion of Carrier Routes from 12-Circuit to 24-Circuit Working," F. W. G. Dye, *P. O. E. E. J.*, Vol. 42, p. 26, April 1949.
- "The Transmission Characteristics of Toll Telephone Cables at Carrier Frequencies," C. M. Hebbert, *Bell Sys. Tech. Jour.*, Vol. 20, pp. 293-330, July 1941.
- "Propagation Characteristics of a Uniform Line," I. F. Macdiarmid and H. J. Orchard, *Wireless Engineer*, Vol. 23, No. 6, June 1946.
- "Effect of Temperature on the Non-loaded Carrier Cable," K. Simizu and I. Miyamoto, *Nippon Elec. Comm. Engg.*, No. 16, pp. 596-599, May 1939.
- "Influence des Variations de Température sur l'Affaiblissement des Circuits de Télécommunication en Cables Enterrés," P. M. Prache, *Cables & Transmission*, Vol. 1, No. 3, October 1947.

Book Review

"Transmission Lines and A.C. Networks." T. F. Wall, D.Sc., D.Eng., M.I.E.E. Geo. Newnes, Ltd. 328 pp. 266 ill. 30s.

This book deals with the transmission of power at mains frequency. The chapters cover a short survey of electric power transmission, the design and construction of overhead lines for medium, high and extra high pressure, the transformer as a link between the generator and the transmission line, characteristics of heavy current cables, short-circuits, protective systems, surges lines, on the economics of transmission lines, calculations of current, current distribution and pressure drop in A.C. networks, current and pressure relationships in long distance power transmission lines.

As one would expect from Dr. Wall the treatment is almost entirely mathematical. The symmetrical component analysis method is used extensively and is fully explained. The mathematics of Petersen coils and surges are fully covered.

The book can be recommended to students taking a degree course in power transmission. Only minor details can be adversely criticised. There are a few mistakes. The table on page 9 should be headed cents per kilowatt hour and not cents per kilometre. The incorrect signs in Figure 3(a) in Chapter III are unfortunate for the student who is being introduced to vector algebra. The use of such suffixes as V_{1-} , V_{1+} and V_1 in equations does not assist rapid reading as the symbols are too much alike. Figures 7 and 25 in Chapter IV do not agree with Figure 4.

There is a certain amount of repetition; loss factor and the oil-filled cable are each dealt with twice. Some of the diagrams seem to have little value, Figure 5 on page 238 is an example. If the space that could be saved without detracting from the value of the book were devoted to taking the student more slowly through vector algebra and symmetrical component analysis, the first-year student would benefit considerably.

A. E. P.

The Provision of Communications for the Coronation of Her Majesty Queen Elizabeth II

S. M. E. ROUSELL, A.C.G.I., A.M.I.E.E.
E. B. M. BEAUMONT, B.Sc. (Eng.), M.I.E.E.
and B. H. MOORE†

U.D.C. 621.39

This article gives an account of the extensive network of communications set up by the Post Office to cover the organisation, control, broadcasting and press reporting of the Coronation of Her Majesty Queen Elizabeth II on 2nd June, 1953.

INTRODUCTION

EARLY in 1952, when it became apparent that the Coronation of the Queen would take place in 1953, it was quickly realised that the efficient organisation and control of a function of such a nature and magnitude, involving a processional route extending over several miles, would require a comprehensive system of telephone communications. In addition, it was evident that an extensive line network would be needed for reporting and recording the occasion by the Press of many nations, by many broadcasting companies and other organisations.

At a preliminary meeting of all the parties known to require communications for the event, arranged by the Telephone Manager, Centre Area, the Area almost exclusively concerned, a general picture emerged. For example, the Army required separate networks for controlling the processional routes, with terminations on vehicles at the kerbside; a synchronised gun-salute system would be required and also installations to cater for 20,000 troops in Kensington Gardens, Olympia, Earls Court, etc. The police required a network centred on Scotland Yard and terminating on the barriers in the streets; also, grouped private-wire circuits for controlling car-parks and camp facilities at Kensington Gardens. The B.B.C. requirements were obviously going to be extremely heavy, as a large number of television cameras and microphones would be in use in the Abbey and on the route; augmentation of their normal network would also be necessary.

The Ministry of Works indicated that they would require:—

- Circuits to all stands, terminating on a Private Branch Exchange to be known as Coronation exchange. Circuits from this exchange would also be required to certain government offices.
- Circuits for the control of the extensive public address system circuits radiating from a centre to all stands.
- A telephone installation in Westminster Abbey for first-aid stations, fire patrols, Gold-Staff control (ushers) and normal intercommunication.

AUGMENTATION OF LINE PLANT

A rapid examination of the spare-pair position, particularly on junction cables, in the area where the processional route would probably lie, showed that considerable additions to the line plant serving certain parts of this area would be necessary. Normal development procedure could not be employed as no suitable forecasts were available, but by allowing very large margins (100 per cent. and more in some cases) in excess of the requirements which were known or anticipated, and having regard to what would probably be the main focal points of the networks, the plans for the augmentation of the line plant were completed by the early autumn of 1952. The work was put in hand immediately.

The results have shown that what was virtually intuitive planning served very well. All essential and most other requirements from all parties were met, although very few spares were left by Coronation Day. A factor kept in mind

during planning was that the bulk of the new cables and duct should be usable afterwards to meet normal growth of circuits in the West End of London; particularly, new junction circuits and private wires using junction cable pairs, e.g. the Museum-Mayfair-Victoria cable will now be used as a normal junction cable. Another aim was to design the sizes of cable so that most of the cable required could be obtained from recoveries in other parts of the London Region. Because of the need to obtain the least possible fault liability, all recovered cable was cleaned, carefully examined, reconditioned as necessary, and comprehensively tested at the Regional Cable-Splicing Depot before being laid. In many cases splices (unidiameter joints) had to be made to obtain suitable jointing lengths.

DETAILS OF MAIN CABLE NETWORK

Fig. 1 shows details of the main cable network provided. The principal new cables were an 800-pair cable from

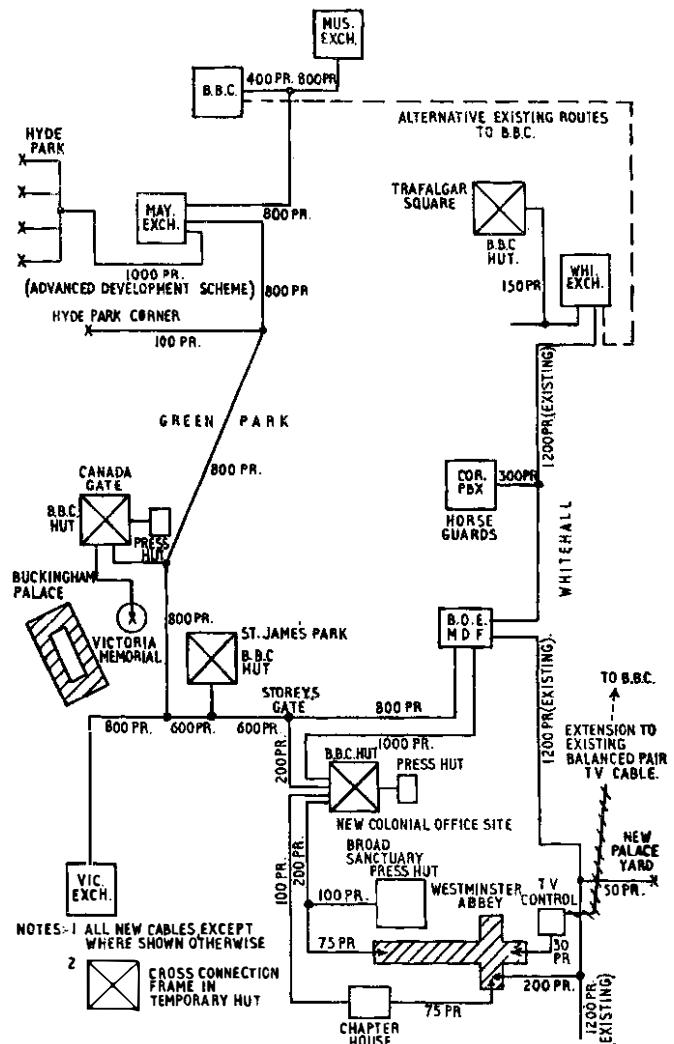

FIG. 1.—MAIN CABLE NETWORK.

† The authors are, respectively, Regional Engineer, Area Engineer and Executive Engineer, London Telecommunications Region.

Museum exchange via Broadcasting House and Mayfair exchange to the Victoria Memorial outside Buckingham Palace, and then on to Victoria exchange; a 600-pair cable from near the Victoria Memorial to a large flexibility frame in Whitehall ("Board of Education" frame); and cables from this frame to the New Colonial Office site, Broad Sanctuary, and to the precincts and interior of Westminster Abbey. Special huts were provided by the Ministry of Works for the use of the Press at the new Colonial Office site, Canada Gate, Broad Sanctuary, and outside Westminster Abbey; and by the B.B.C. for their control rooms at points on the route and outside Westminster Abbey. The cables were terminated on distributing frames at all these points and, with the exchange main frame adding its quota, the cable network acquired a very high degree of flexibility, making it possible to provide a wide variety of routings and to give alternatives where necessary, e.g. for B.B.C. circuits.

The method of leading cables into the B.B.C. hut at Canada Gate near Victoria Memorial was somewhat novel. The hut was erected over a double junction joint-box so that the joint-box became, in effect, the "cable trench" of the orthodox telephone exchange. The covers were removed and the floor of the hut was cut and made removable.

New ductwork was required in several places, particularly in the neighborhood of the Victoria Memorial outside Buckingham Palace where only a small iron pipe of uncertain capacity existed. Opportunity was taken to lay a 4-way duct route from near Mayfair exchange across Green Park, under the Mall near the Victoria Memorial, and then to Birdcage Walk, where it divided and was extended to a point near Victoria exchange in one direction and to Parliament Square in the other. Fig. 2 shows the work in progress near



FIG. 2.—EXCAVATING FOR DUCT ROUTE NEAR CANADA GATE.

Canada Gate. The route across Piccadilly, before entering the Park, had to be in the immediate vicinity of Green Park station and it was necessary to tunnel very near to the concrete of the roof of the escalator shaft.

A difficult permission to obtain was for the provision of a duct track across the mouth of the Mall near Victoria Memorial. The carriageway is paved with a special red asphalt macadam and, as it is extremely difficult to match the colour when reinstated, the Ministry of Works stipulated tunnelling. As the whole of the ground in this area is "made-up" and there are also some large water pipes feeding and draining the Victoria Memorial fountains, tunnelling was undertaken with some apprehension. No serious difficulties were encountered, however, and completion was effected by the end of January 1953. In order to meet the

Ministry of Works request to avoid marking the asphalt and paving with spoil, the whole of the area around the working points was washed after completion—a very unusual procedure.

This new duct has provided a very valuable North-South junction route for this part of London at unusually low cost because a large portion of the route was through the Royal Parks where reinstatement costs are low (mainly grass or tarred-gravel footpaths) compared with the cost of reinstatement in the main streets of the West End of London. Furthermore the route is much shorter than the alternative one via either Grosvenor Gardens or Whitehall, so enabling smaller gauge conductors to be used to meet the limits for signalling and transmission for the normal circuits which will subsequently use this cable.

SCOPE OF THE COMMUNICATIONS PROVIDED

When the full extent of the requirements became known they fell into the following main groups:—

- (a) Circuits for the organisation of the event.
- (b) Communications within Westminster Abbey.
- (c) Communications for the control of the procession.
- (d) Circuits for control of the gun salutes.
- (e) Circuits for control of the R.A.F. "fly-past."
- (f) Circuits for control of crowds and car parking.
- (g) Circuits for public address systems.
- (h) Sound broadcasting and television requirements.
- (i) Press requirements.
- (j) Miscellaneous, such as telephone service for tented camps, liners in Port of London, etc.

In the following paragraphs brief descriptions are given of the methods of providing the various circuits and facilities required, with particular reference to unusual engineering features or difficulties.

Circuits for the Organisation of the Event.

In the first place it was necessary to provide an adequate telephone service at premises in Belgrave Square used for an enlarged Earl Marshal's office dealing especially with the Coronation preparations. The service was provided by means of a 2-position P.M.B.X. 1A switchboard which was in operation from September 1952 until after the Coronation.

The responsibility for providing all stands, decorations, etc., both inside and outside the Abbey rested with the Ministry of Works. This entailed organising a very considerable engineering project and the Ministry of Works required a comprehensive network of telephone circuits connected to a switchboard known as Coronation exchange. This exchange, which was in operation during the whole of the final preparation and dismantling, was opened on 16th February, 1953. It also served an important purpose on Coronation Day when it operated as the central control for maintenance and service matters and for communications to the stewards on the stands along the processional route. For strategic engineering reasons the choice of a site for this switchboard fell on a lately vacated suite of C.B. No. 9 switchboards in the Horse Guards Building under the control of London District Signals. Part of the suite was also used for a military control and for the control of the Ministry of Works public address system. These premises were served without difficulty by extending, into the building, pairs in an existing 1,200-pair cable running along the west side of Whitehall.

There were individual external extensions to the main stands on the procession route. These were brought into operation on each stand as soon as the main framework and weather protection were completed. A 7-pair cable was run to each stand from the nearest convenient point in the permanent underground cable network. The normal

requirements were 1 pair for a telephone circuit to Coronation P.B.X., 2 pairs for a public address system (see also later) and 1 for an engineering speaker for control of maintenance staff on the route. 7-pair cable was used to allow a margin of spares for last-minute additions and for clearing faulty circuits by diversions, two of the spares being earmarked as reserve circuits for the public address system.

Communications within Westminster Abbey.

The work undertaken by the Post Office in Westminster Abbey consisted of providing:—

- (a) wiring and cable to microphone points for the B.B.C. (sound and television),
- (b) a special switchboard in the Triforium for service within the Abbey on extensions to Fire Guards, Medical Officers, Gold-Staff, etc., each telephone having a non-audible (lamp) signalling facility,
- (c) a multiphone switchboard in the Triforium for giving the Gun-Salute signal,
- (d) telephone facilities for the Press,
- (e) wiring to various points for the control of news-reel cameras within the Abbey,
- (f) an extension for giving the signal to sound the bells of the Abbey at the moment of crowning.

The main consideration in wiring and installing equipment of any kind was that no attachments should be made to the fabric of the Abbey save such as could be removed without leaving any permanent marks. This prevented the use of nails, screws, cleats, etc., and involved the use of clamps and ties of various descriptions. Moreover, microphone circuits of necessity use single-pair lead-covered cable and the long and awkward runs of cable for all purposes was a feature of the installation not encountered in normal practice. In all about 7,000 yds. of single-pair lead-covered cable was employed.

Another feature of the installation was the tentative nature of the initial provision due to a degree of uncertainty arising because of the rival interests such as sound broadcasting, television, colour photography and the public address system within the Abbey. Conflicting requirements were generally reconciled by the Earl Marshal himself, and inevitably such compromises affected the final positioning of the wiring. This was particularly difficult in the vicinity of the Altar where microphones had to be sited within extremely narrow limits to avoid excessive background noise and pick-up from the public address system. Another consideration was the fear that much of the wiring would be regarded by the photographers and television experts as being unsightly and an obstruction to their operations; this made the problems of fixing and suspending exceptionally difficult.

The switchboard for internal communications consisted of two 65-line floor-pattern boards, with power supplied by a Rectifier 38C and secondary cells, in a room in the Triforium and overlooking Parliament Square. The extensions had lamp-signalling telephones using a non-standard 25-V circuit and 4-wire cabling.

The multiphone switchboard was housed in a cubicle built by the Ministry of Works in the Triforium overlooking the dais and the Altar. This cubicle was 47 in. high and 6 ft. by 6 ft., and during much of the ceremony contained two officers complete with dress-swords together with a P.O. Engineer and a M.O.W. official. Fig. 3 gives an impression of the conditions. Over their heads was mounted a television camera with commentator in attendance. At the moment of crowning, the officer transmitted the command to "Fire" the Royal Salute simultaneously to Hyde Park, Windsor Great Park and the Tower, while the M.O.W. engineer signalled by telephone for the bells to peal.

The Press was 300 strong and also in the Triforium. They were provided with a temporary hut outside the

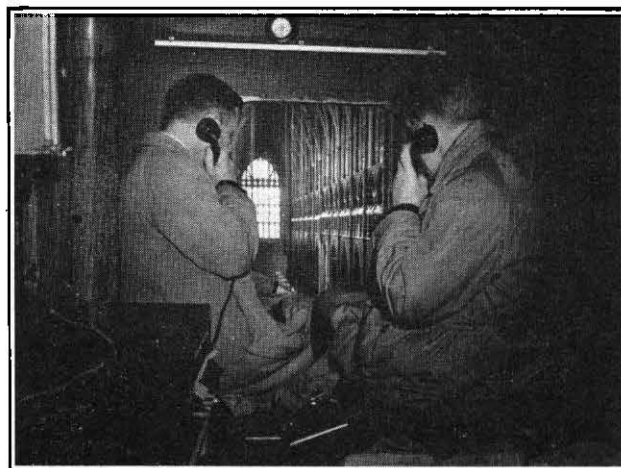

FIG. 3.—MULTIPHONE SWITCHBOARD IN CUBICLE IN TRIFORIUM.

building and abutting on the North Wall with a gravity chute from the Triforium for written messages. This hut being tented and the weather cold and damp, heating was found necessary to reduce humidity.

Control of the Procession.

The stopping and starting of the Procession depended on a signal from one of two points. For the "To" Procession, that is the procession to the Abbey in the morning, the signal was initiated from the Victoria Memorial opposite to Buckingham Palace. For the return Procession the signal was given from the Sanctuary Stand opposite to the main entrance to the Abbey (West door), Fig. 4. In each case an



FIG. 4.—TELEPHONES IN SANCTUARY STAND.

officer of the London District Signal Regiment was responsible and his signal was transmitted by telephone to suitable points on the Route so that the Procession could be set in motion (or halted) at several points simultaneously so as to avoid unnecessary congestion. [Conversely, individual points advised Control and their fellows, in conference, from time to time as congestion occurred (as happened, for example, in Trafalgar Square), so enabling action to be taken to avoid eddies in the Procession.] The signal was also duplicated by a second officer alongside who transmitted his instructions simultaneously into a microphone and thence,

using the military radio set (frequency-modulated) on a wavelength of about 3 Mc/s, to the same receiving points *en route*.

The various control points took the form of "Jeeps" staffed by three or four Royal Signals personnel manning radio sets and with the G.P.O. telephone in a weatherproof box. The arrangements in a Jeep are illustrated in Fig. 5.



FIG. 5.—PROCESSION CONTROL JEEP.

For the morning Procession two points only were concerned, one at the Victoria Memorial and the other on the Mall near the Duke of York's Steps, and the system was quite straightforward, being merely a private wire with duplicate radio. For the return Procession, however, it was necessary for several points to be given the command signal simultaneously, and Fig. 6 shows the telephone network provided. A multiphone system was envisaged initially but for engineering reasons it was decided that the switchboard must be situated in the Horse Guards Signals Centre; and this being so, control from the Sanctuary Stand would

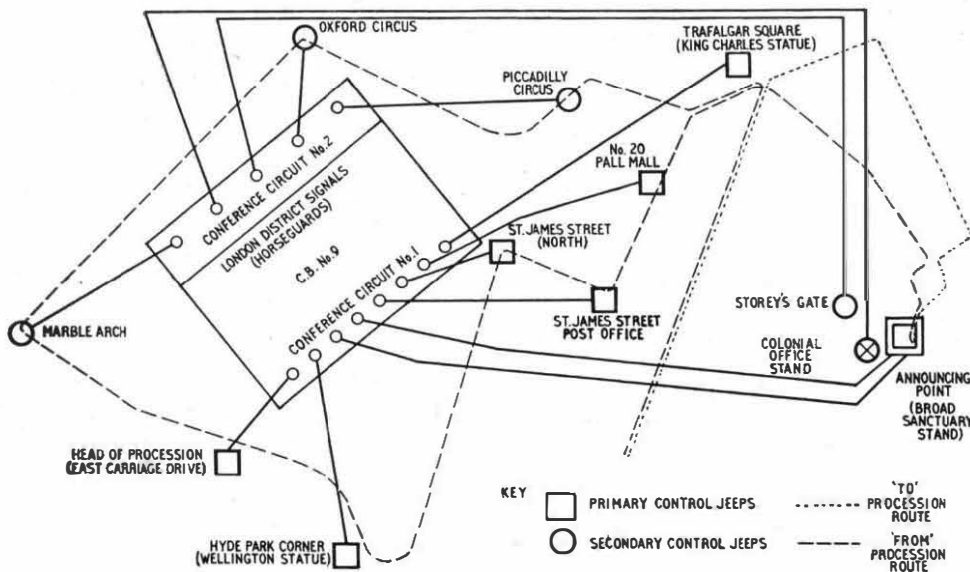

FIG. 6.—PROCESSION CONTROL NETWORK.

involve a "remote announcing circuit" with amplifier. This complication (which is the standard arrangement for multiphone working), involving as it did the use of eight cable pairs to reduce the resistance to within the necessary limit led the Area to experiment with more simple means, using the remainder of the existing C.B. No. 9 switchboard with straightforward external extensions to the various points. Conference facilities being provided by simply throwing the necessary number of "speak" keys simultaneously. Since there were, in addition, subsidiary points on the route to which separate communications would be desired and to which separate conference facilities might be necessary, a second operator's circuit was wired on the same position to give a second conference facility with transfer circuits to the Coronation board adjacent. The system was first demonstrated without any attempt being made at equalising the various circuits although the resistance of the lowest was 120 ohms; and of the highest 860 ohms. Local-battery telephones were used at each of the points and the demonstration proved reasonably satisfactory with seven points in conference. To provide some margin of safety for the actual event, all the circuits were subsequently equalised to a minimum of 600 ohms, by the insertion of resistors on the I.D.F. in the Horse Guards switchroom, and the Royal Signals were recommended to use a sensitive receiver at each of the telephones, comprising a non-standard balance armature inset receiver with an adapter for inserting in the G.P.O. standard hand micro-telephone. In the event it proved possible to give intelligible directions in the face of considerable crowd-noise with all 12 points in circuit together and it is estimated that the sensitive receiver improved reception by about 3 db. at each station.

Connection at each Jeep was effected by mounting the local-battery telephones and their three dry-cells in a weather-proof box with external terminals clearly marked for polarity since an L.B.-C.B. assisting circuit was employed. The external cable pair was taken at each point to a terminal block mounted on a lamp-post or other suitable existing structure with a battery box containing a coil of sufficient drop-wire to reach to the Jeep over the heads of the crowd. The Jeeps were in position at midnight on Coronation Eve and all connections were made satisfactorily.

Control of the Gun Salutes.

It has for long been the tradition at the instant of Crowning to fire Royal Gun Salutes at widely separated points, namely, the Tower of London, Hyde Park and Windsor Castle. The War Office asked the Post Office to arrange suitable telephone communications to enable the order to fire the guns to be given by an officer at Westminster Abbey and to be received simultaneously at each point. A requirement such as this could be met by a multiphone system at the standard Post Office multiphone switchboard with an amplifier as was used. It was decided as a safeguard to insert an amplifier as the bunching losses together with the line loss of the longest circuit (to Windsor) totalled about 17 db., and since only low-level speech could be used in Westminster Abbey, it was considered desirable to reduce the worst transmission loss to about 6 db. Fig. 7 shows the details of the system. In the event, however, the users preferred not to have the amplifier in use—an interesting psychological reaction.

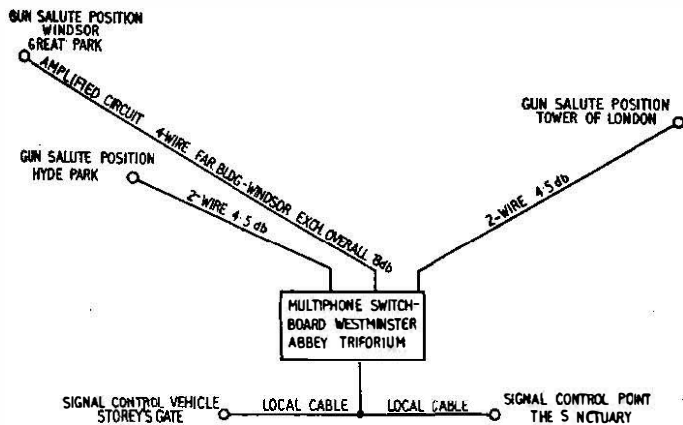

Note.—Signal Control Vehicle housed army radio equipment also used to control procession. Signal Control Point at the Sanctuary not directly concerned with gun salute but mainly for procession control; it was, however, required to be aware of progress of service in Abbey.

FIG. 7.—GUN SALUTE CONTROL NETWORK.

Circuits for Control of R.A.F. "Fly-Past".

The R.A.F. set up a mobile radio station in Regents Park, accommodated in several vehicles, to control the ceremonial fly-past, and telephone circuits were required between Regents Park and an observer post on the roof of Buckingham Palace and also between Regents Park and Biggin Hill Airfield Control Room. The position of the mobile control in Regents Park was such that several hundred yards of cable had to be provided on a temporary basis from the nearest permanent Post Office plant. This cable was laid direct in the ground—trenching being done by a Post Office contractor. As a master control an R.A.F. officer on Stand 70, using a private wire to the roof of Buckingham Palace, provided a running commentary for retarding the assembly and release of the aircraft over Kent, depending on the actual progress of the ceremony and procession. An ultimate delay of 21 minutes was accommodated in this way.

Control of Crowds, and Car Parking.

This was, of course, the particular responsibility of the Metropolitan Police. In order to control the public round the processional route, large wooden barriers were erected at each road intersection and the Metropolitan Police asked for circuits from their P.B.X. at New Scotland Yard to each main barrier. These circuits terminated at the barrier on a standard wall-type hand micro-telephone instrument mounted in a secure wooden box. In all 23 of these circuits were provided.

In order to control the parking of motor-cars of guests attending the Coronation Service in Westminster Abbey and to provide a "car-call" service at the termination of the proceedings, a total of 34 point-to-point local battery telephone circuits were provided. The A-ends were grouped at several points near the appropriate exits from Westminster Abbey and New Palace Yard (luncheon facilities were arranged in the Palace of Westminster). The B-ends were, of course, located at the various car parks, many of which were on the other side of the River Thames, and nearly all needed routing in junction cables. Thanks to this system of telephones, the flow of cars was smooth and there was little congestion of traffic or waiting by the distinguished guests.

It was considered that there was a need for permanent facilities so that a car-call telephone service outside Westminster Abbey and New Palace Yard could be available on demand at any time, and a number of footway boxes were provided together with short pieces of mild steel pipe to the base of lamp-posts or other suitable points. Each pipe is terminated with a screwed brass socket. When a car-call telephone service is required a short length of vertical pipe

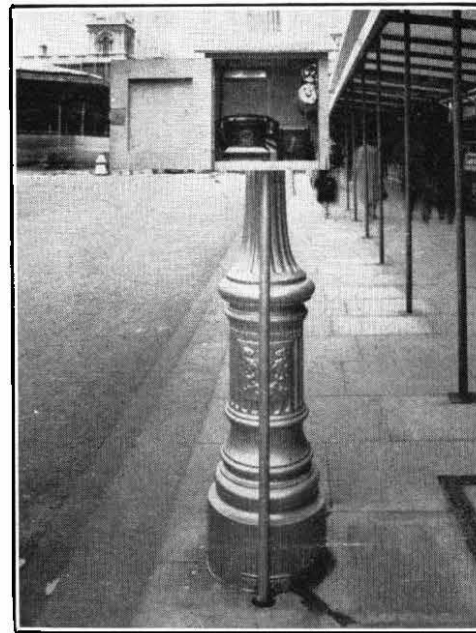

FIG. 8.—TELEPHONE ON LAMP-POST FOR CAR-CALL SERVICE.

can be screwed into the socket and a local-battery telephone fitted to the lamp-post (Fig. 8) at the appropriate height and connected by a temporary lead to the D.P. cable in the joint box.

Circuits for Public Address Systems.

As mentioned earlier each official stand on the route of the procession was provided with a public address system. This could be used for disseminating information and instructions, a musical programme from records during waiting periods, a relay of the Coronation Service as it took place in Westminster Abbey, B.B.C. commentaries of the Ceremony in Westminster Abbey, or the progress of the Procession.

Considerable flexibility in the system was required so that each stand could be handled separately if necessary. A separate network was used and the whole system was centred on a special board in a room adjacent to the Coronation switchboard at Horse Guards Arch. The equipment for the system and the wiring on the stands was provided by the Ministry of Works' Contractors, the Post Office providing the external lines. The distribution of the programme over the Post Office circuits was at low level with an amplifier on each stand so that pairs in ordinary telephone cables could be used without risk of overhearing.

In addition to this system, a number of private stands arranged for the relaying of programmes by radio-relay companies and additional circuits for this purpose were provided by the Post Office in several areas.

Sound Broadcasting.

There were over 100 commentators in action during the sound broadcast, spread round the 11 outside broadcast control points shown in Fig. 9. Some control points had only one commentator, while the largest had 28, and, where existing premises could not be obtained, the B.B.C. arranged for temporary huts to be erected.

Circuits were provided from every control point to Broadcasting House and some had circuits to the B.B.C. recording and overseas transmission premises. The facility was also required to cue and feed back the Westminster Abbey ceremony to each control point. A total of about 1,400 circuits was provided between the various points.

For the Canada Gate site, commentator positions were situated on the Victorial Memorial and linked with the

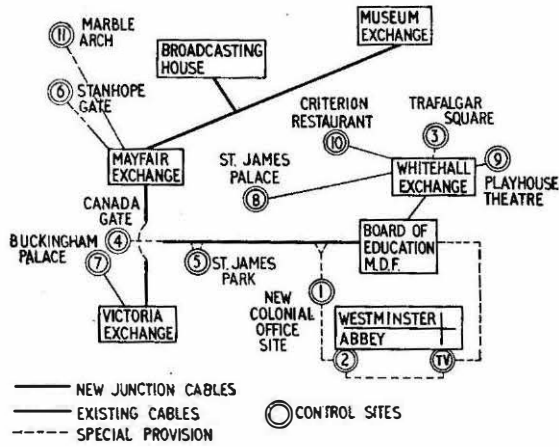

FIG. 9.—BROADCAST CONTROL POINTS.

control point by separate cables for low-level and high-level transmission circuits.

The requirements for a single commentator to the control point consisted of one microphone circuit, one spare microphone circuit and six circuits for cue and control. This meant the provision of three separate cables, and where a number of commentators' positions were concentrated, the total number of the three types of circuits were arranged in three multicore cables to a point central to the commentators' boxes and two 1-pair and one 7-pair cables extended from the termination point to each commentator's box.

There were ceremonial microphone positions provided in Westminster Abbey (Fig. 10), 20 being in and around

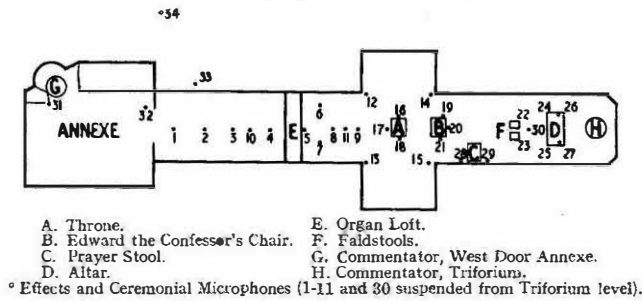

FIG. 10.—MICROPHONE POINTS IN THE ABBEY.

the "theatre." The suspended microphones were at a height that would not interfere with any camera for news-reel or television.

In addition to the Home broadcast circuits, the B.B.C. required facilities for overseas transmission, and circuits were needed to Continental Trunks and the Radio Transmitter Terminal. The majority of these were Programme circuits requiring a frequency band from 50 c/s to 8,500 c/s and special care had to be given to their routing. Although these circuits were wholly within the L.T.R. some difficulty was experienced in obtaining circuits in suitable unloaded cables or cables of suitable composition or to points where amplifiers were available. The Lines Branch, Engineering Department, gave valuable assistance in the loan of cable pairs in M.U. cables and, in all, about 75 miscellaneous and overseas circuits were provided.

In view of the considerable number of broadcast circuits involved it was decided to allocate a special code with full numbering sequence. The code "CRA" was chosen and the B.B.C. circuits were allotted the first thousand in the numbering.

This scheme of coding and numbering provided quick identification of circuits associated with the Coronation and enabled provision and faulting to be given priority.

Television Broadcasting.

There were six mobile control rooms in use for the Coronation, representing eighteen cameras, operating at five different Outside Broadcast sites. It was not possible for one Producer to observe the pictures from all cameras as is normally arranged in television broadcasting, so it was anticipated that the B.B.C. would require the main outputs from the individual control rooms to be concentrated at Broadcasting House.

It was decided to use exclusively for the vision transmission from Westminster Abbey the special television balanced-pair cable, which was originally provided in 1937 for televising the procession of the Coronation of H.M. King George VI and now forms a main link to Broadcasting House from many points for outside broadcasts. The four other main circuits into Broadcasting House had therefore to be planned without using this cable.

There exist, however, a number of coaxial cables used for television outside broadcasts and the four remaining circuits were routed in telephone cables using methods described elsewhere* so that these coaxial cables could form main links.

Fig. 11 shows the arrangement, and it will be seen that in all cases the vision links had to take circuitous routes to Broadcasting House.

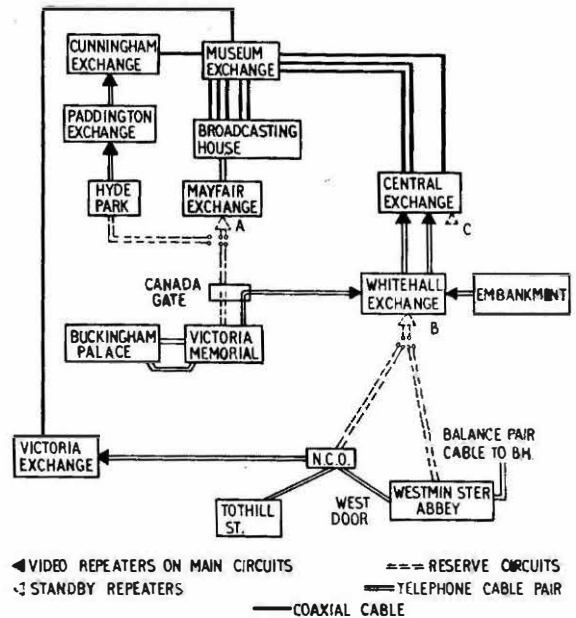

FIG. 11.—TELEVISION CIRCUITS.

The circuits for the new Colonial Office and the Hyde Park sites were obtained by opening junction cables and extending a few spare pairs to the control point. This method was employed as the most economical and, by intercepting five spare junction pairs, the routing for the vision circuits and nine other circuits was obtained. This was later to provide a double advantage.

Fig. 11 shows that seven video repeaters, the total held by the L.T.R., were in simultaneous use for the broadcast, and, in view of the importance of the occasion, application was made for standby repeaters to be held. The Engineering Department arranged for three repeaters to be loaned for a period to cover the rehearsals and the broadcast.

With the operative repeaters in use at five different Exchanges, and assuming that movement of vehicles would be difficult after 6 a.m. on the morning of the broadcast, it was problematical where best to site the standby repeaters. A solution was found after discussion with

* P.O.E.E.J., Vol. 40, p. 33, and Vol. 42, p. 76.

the B.B.C. when, to cover their own emergency arrangements, it was agreed that the Embankment circuit would be used only for a short period in the early procession from Buckingham Palace to Westminster Abbey. After this, the circuit could be closed until late evening when it would be required for the firework display. The B.B.C. agreed that this circuit could be released after the procession had passed the site, allowing the associated repeater and the main portion of the circuit from Whitehall Exchange to Broadcasting House to be used as a reserve link.

In Fig. 11 the broken lines show the routing of the reserve circuits and the broken triangles the reserve repeaters. It will be seen that two reserve repeaters provided standby facilities for five operative repeaters and four circuits. The third standby repeater was held as a spare at Central Exchange.

The reserve circuits were brought into use in accordance with the sequence of use for the various main circuits. When the Royal Procession left Buckingham Palace, pictures were available from all outside broadcast sites to Broadcasting House, and, in addition, duplicate pictures were provided from the Victorial Memorial via Mayfair Exchange. When the Procession approached Westminster Abbey, duplicate pictures from the new Colonial Office site were made available by switching out the Embankment circuit. Similarly, during the Abbey ceremony, duplicate pictures from Westminster Abbey were made available by switching at Whitehall. After the ceremony and the commencement of the main procession, duplicate pictures from Hyde Park and Victorial Memorial were arranged in turn. The change-over from one circuit to another, using the Mayfair repeater, required a change of equalisation but there was ample time between the uses of the circuits for this to be arranged. The change-over of the circuits at Whitehall had to be made quickly and a remotely controlled switching relay was fitted at Whitehall (see Fig. 12) and operated from Broadcasting House.

The pictures transmitted to Holland and Germany took the English commentary with simultaneous interpretation in the language of the particular country concerned.

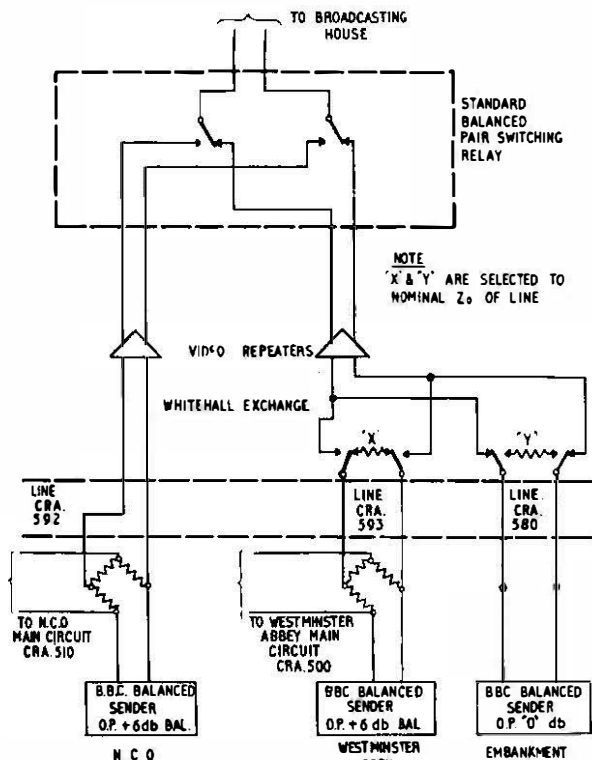

FIG. 12.—TELEVISION SWITCHING ARRANGEMENTS AT WHITEHALL.

The French had commentators at all sites, and music and control circuits were provided and routed to Broadcasting House where a special control point was installed for cueing so that commentators could be brought in as pictures from the various sites were selected for transmission.

Press Requirements.

The demands for circuits for the Press, both British and Foreign, were very heavy. As mentioned before, special temporary huts to serve as press bureaux were provided by the Ministry of Works for the exclusive use of the Press. Plans for the telephone layout in these bureaux were prepared by the Centre Area and the Ministry of Works arranged for their contractors to provide the necessary tables and benches. The final requirements in each hut were as follows:—

Westminster Abbey (North West Precincts).—29 Private Wires, three 4-cubicle suites of attended Call Offices and 10 M.C.B. Exchange Lines.

New Colonial Office (opposite West Door of the Abbey).—15 Private Wires, one 3-cubicle suite of attended Call Offices and 6 M.C.B. exchange lines.

Canada Gate Green Park (near Victoria Memorial).—20 Private Wires, two 3-cubicle suites of attended Call Offices and 6 M.C.B. exchange lines.

As mentioned before, there were 300 pressmen in the Triforium in Westminster Abbey, and in addition there were 150 outside Westminster Abbey in the vicinity of Parliament Square and 150 in the neighbourhood of Buckingham Palace. The result was that conditions in the bureaux were extremely congested and the noise level very high; since pressmen are accustomed to telephoning under such bad conditions they accepted the position and made no complaints. The attendants were empowered to accept trunk, continental and overseas calls on the call offices. Fig. 13 illustrates the interior of the hut at Canada Gate.



FIG. 13.—INTERIOR OF PRESS HUT AT CANADA GATE.

In addition to these special huts, the Press rented a good deal of private accommodation at vantage points along the processional route and several special circuits were required. In one case a press agency requested an omnibus circuit connecting five of their reporters together and back to their head office so that each reporter could hear the messages passed by the others and so avoid duplication. In the interests of cheapness and reliability multiphone working was not offered, but it was possible to provide a tee system with transmission losses not more than 15 db. between any two points, which was acceptable to the press agency, particularly as the loss from each reporter to head office and between adjacent reporters was much less.

Miscellaneous.

There was considerable demand for special circuits arising from the Coronation but not directly concerned with the control or reporting of the proceedings. In the first place numbers of direct exchange lines and private wires were required to serve the large camps in Kensington Gardens for the Army, R.A.F. and Police. There is very little permanent line plant in the interior of the Gardens and, although there was one cable which was laid in connection with the Victory processions, temporary cables had to be laid to several points. The extensions were wired by Royal Signals. In addition to lines for the administration of the camp, a number of call-offices were erected—weatherproofed cabinets—to provide amenities for the troops while in the camps. Facilities for overseas calls were made available for Colonial troops. Exhibition buildings at Olympia, Earls Court, etc., and a further camp at Wormwood Scrubbs were also used to house troops.

Another special demand was for public telephone service to a number of liners used as floating hotels and moored in the Thames or in certain of the docks during the Coronation period. Circuits were also required for administrative purposes for a number of warships moored in the Thames. Sub-aqueous cables were provided to a number of mooring buoys, terminated on a waterproof resilient moulded rubber socket with a plug for sealing the unit when not in use. Some of these connections may be left in position to meet a growing demand for telephones for ships moored at these buoys in normal course.

MAINTENANCE ARRANGEMENTS

It was obviously necessary for staff to be available on Coronation Day to cater for possible contingencies: it was equally certain that mobility would be negligible after about 7 a.m. It was arranged, therefore, for officers who had local knowledge of the installations, and who had in fact installed the system, to be stationed at strategic points from early morning until after the procession had returned to Buckingham Palace. A central control of these units was instituted with an Area Engineer in charge in the Centre Area T.M.H.Q. which also catered for skeleton arrangements for normal maintenance during the day. All staff required to work within the totally-enclosed part of the processional route were required to be on duty before 6 a.m. in the morning and it was necessary, therefore, to make arrangements for sleeping in surrounding buildings on the previous night. Mayfair and Whitehall exchanges,

together with premises such as Sanctuary Buildings which were put at our disposal by the Ministry of Works, were used. The telephonists' refreshment clubs provided very welcome breakfasts and packed lunches as required by the men.

CONCLUSION

The provision of communications for all concerned with the organisation, control and reporting of the Coronation Ceremony and Procession, was a very heavy commitment for the Post Office involving a total of nearly 3,000 circuits provided for the various organisations. No fundamentally new designs of apparatus or plant were used, but much ingenuity was displayed in adapting standard apparatus to the peculiar needs of the occasion. Although most of the circuits were only required for a very limited period, methods had to be used throughout to ensure the lowest possible liability to faults since the continuity of communications during the event was of paramount importance.

Experiences on Coronation Day showed the physical telephone circuits to be more dependable than the short-wave two-way radio network under the conditions prevailing, and the former were much preferred by the London District Signals staff for the control of the procession.

During rehearsals failures were noted on two out of twelve of the transmitter inserts due to high resistances developing and spare inserts were carried on 2nd June.

The few faults which developed during the day on the Post Office circuits were entirely due to the cold rain which fell at intervals. For example, an instrument cord on the Hyde Park gun-salute telephone was affected and the instrument had to be changed. For future similar events weatherproof cordage on all telephone instruments would be an advantage.

As is well known now, the circuits for the B.B.C., despite their complexity and the switching involved, were entirely free from faults during the periods they were in use. It is safe to say that the satisfaction of all the participants, and of millions of observers, listeners and viewers was dependent on the efficient work of the Post Office Engineering Department on this important occasion.

The authors wish to acknowledge the help and information given to them when preparing this article by many of their colleagues and in this connection to mention in particular Mr. L. G. Wootten, Area Engineer (External) and Mr. A. G. Orchin, Sales Superintendent, Centre Area L.T.R.

Book Review

"Generation, Transmission and Utilisation of Electrical Power." 3rd Edn. A. T. Starr, M.A., Ph.D., M.I.E.E. Sir Isaac Pitman & Sons, Ltd. 517 pp. 432 ill. 20s.

The author states in his preface that his object was to present the student who is studying for the Engineering Degree, Faraday House Diploma, National Diploma, or National Certificate, with a single book containing a description of the syllabus known as electric power. He adds that the syllabus is so wide that a choice must be made as regards not only the matter to be included but the depth of treatment. As a description of the book, this is difficult to improve.

Generation is dealt with in one chapter; there are six on transmission, and one each on voltage regulation, switchgear and protection, short-circuits and transients, illumination, traction, industrial utilisation and economics. The mathematics of alternating current theory are reserved to one of seven appendices, the others covering transformers, Thévenin's theorem, static converting plant, heating, welding and electrochemical processes. There are numerous questions at the end

of each chapter; most of these are from London University examination papers. The answers are also given.

The book is obviously not intended for the first-year student as the depth of treatment varies considerably. On generation for example, the reader is assumed to be familiar with entropy and the Mollier diagram. No two engineers would, of course agree on the subjects which should be included or omitted and the depth of treatment of any subject. The author obviously feels that transmission should receive the greatest attention. In view of the popularity of fluorescent lamps something more than half a page might have been devoted to them. Instant-start lamps receive no mention at all. The chapter on traction is largely concerned with electric railways; but trolley buses and trams receive some mention. Batter vehicles are dismissed in three short sentences. The omission only serve, however, to show the difficulty that faced the author in choosing his material.

The book is a mine of information on a wide range of subject and well balanced between theory and practice. It should prove very useful to those who, having studied at degree level, require to have at hand for revision purposes a survey covering the field of electric power.

A. E. P.

The Post Office Standard Motor Uniselector

C. A. MAY, M.A., A.M.I.E.E.†

U.D.C. 621.395.636:621.395.343

This article gives a detailed description of the construction and operation of the Post Office standard motor uniselector which is to be used as a group selector in the automatic trunk exchanges now being installed in this country.

INTRODUCTION

MOTOR uniselectors have been in use in this country in Messrs. Siemens Brothers original form since 1932 and in the British Post Office since 1935, when some 600 were installed as line finders in North exchange, London. Further use in the Post Office has been slight but a considerable number of uniselectors have been employed by British Railways and the London Transport Executive in their private telephone systems.

The facility available in the motor uniselector whereby rapid testing over a large number of contacts is possible renders it eminently suitable for use in automatic trunk exchanges, and the uniselector has therefore been adopted for this purpose. It will also be used in various circuits in connection with the Cordless Switchboard System. The item adopted has been coded as "Uniselector Motor Drive No. 2." and Fig. 1 shows its general assembly.

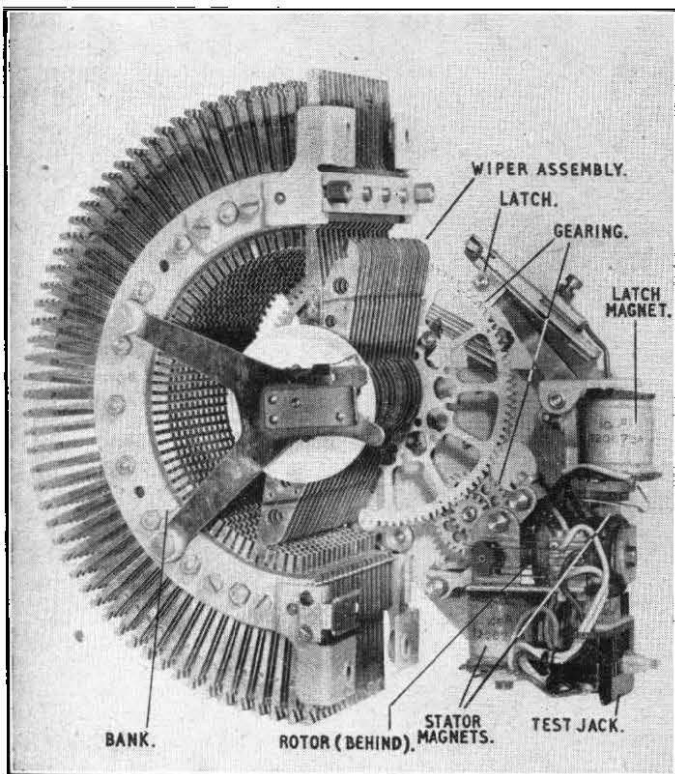

FIG. 1.—THE UNISELECTOR, MOTOR DRIVE, NO. 2.

This article gives a number of details of the operation and construction of the switch.

OPERATION

The uniselector consists basically of a simple self-interrupting two-pole motor driving a wiper assembly through a train of gears. Stopping of the wiper assembly is achieved by the release of an electromagnet latch. The release of this latch, which also breaks the motor circuit, may be carried out by two distinct methods: the first, which can stop the wipers only at certain pre-

determined positions, consists of the operation of a spring-set, mounted on the mechanism frame, by cams fitted to the wiper assembly. The normal provision of such cams is one for switches having single-ended wipers and two for switches having double-ended wipers. This method of stopping is normally used to return the switch to its "home" position, or positions, after it has performed its circuit function.

The alternative method of releasing the latch is by the operation of a high-speed relay, controlled by the electrical conditions existing on the bank contacts over which the wipers are hunting. This is the normal method of positioning the wipers during operation. The uniselector will not respond directly to impulses.

The speed limits for all uniselectors are 170 to 230 contacts per second: switches having not more than eight wipers in the bank at one time can, however, be controlled to between 200 and 230 contacts per second. Switches having very light wiper loads have a copper slug fitted to each motor coil in order to restrict the speed to within these limits.

The speed may be varied by some 25 to 50 contacts per second by adjustment of the interrupter position.

CONSTRUCTION

Magnets, Armature and Interrupter Assembly.

Fig. 2 shows an exploded view of the motor mechanism and Fig. 3 indicates the circuit arrangements by which self-drive conditions are obtained.

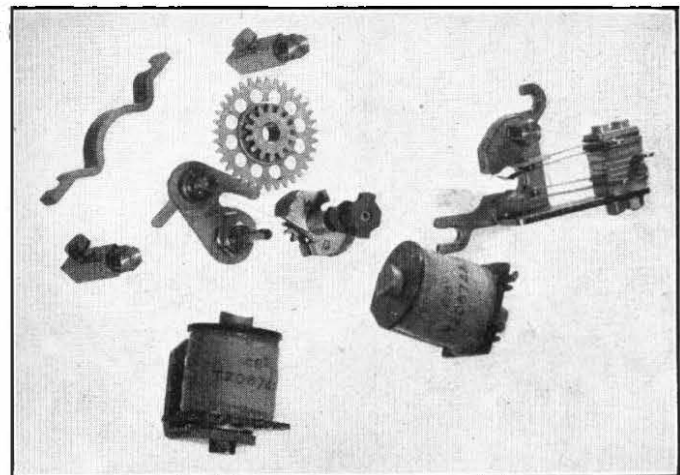

FIG. 2.—EXPLODED VIEW OF MOTOR MECHANISM.

Each magnet coil consists of 2,200 turns of 0.0088-in. enamelled copper wire wound on a soft iron core, the coil cheeks being of synthetic resin-bonded paper (S.R.B.P.). The end of the core adjacent to the armature is concave so that the armature may rotate close to it with the minimum of air gap. The resistance of each coil is 48 ohms.

The soft iron armature, which is not wound, is keyed to a mild steel pinion which rotates freely on a spigot-type stainless steel bearing, through which passes a lubricating wick. The shape of the armature blades ensures an adequate starting torque and determines the direction of rotation.

† Executive Engineer, Telephone Development and Maintenance Branch, Engineer-in-Chief's Office.

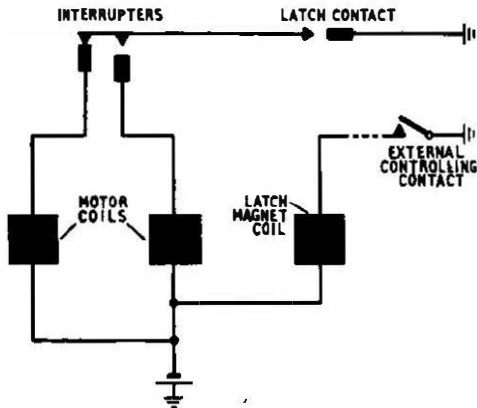

FIG. 3.—SIMPLIFIED CIRCUIT OF MOTOR UNISELECTOR.

Fixed to the end of the armature assembly is a cam of loaded ebonite which operates the interrupter springs. The symmetrical construction of the springsets and the fact that the fixed spring of each action is tensioned lightly against the circular portion of the cam ensure that wear in the bearing or irregularities in the straightness of the spindle do not interfere with the adjustment of the contact openings.

A spark quench consisting of a $1\ \mu\text{F}$ capacitor in series with a 10-ohm resistor is connected across each pair of contacts.

Banks.

These consist of 8 or 16 arcs of 51 contacts, each arc occupying $173^{\circ}5'$. The contacts are of nickel silver and are clamped between S.R.B.P. insulators, the arcs being separated by aluminium spacers. To minimise crosstalk the spacers are connected to earth by means of a serpentine nickel-silver wire making contact with each spacer and with the bank frame. Fig. 4 shows a typical 16-level bank with one brush feed assembly removed.

Because of the absence of any percussive forces, such as are found in ratchet switches, motor uniselectors are comparatively free from vibration. It is not, therefore, necessary to mount the uniselectors on rubber blocks or

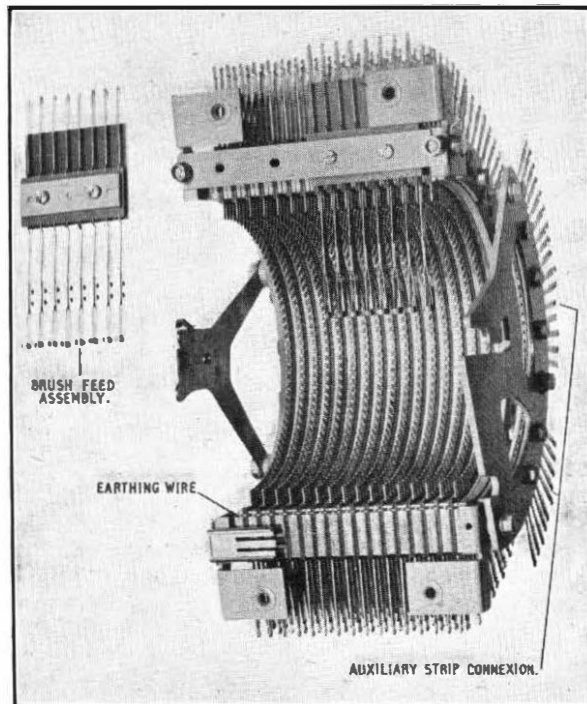

FIG. 4.—A 16-LEVEL BANK WITH ONE BRUSH FEED ASSEMBLY REMOVED.

insulated metal springs as is customary with other selectors and the banks are rigidly bolted to the rack framework. The mechanism frame is thus always earthed when in the bank and, to assist in maintenance, an insulated outrigger is available. Fig. 5 shows a mechanism fitted in an outrigger.

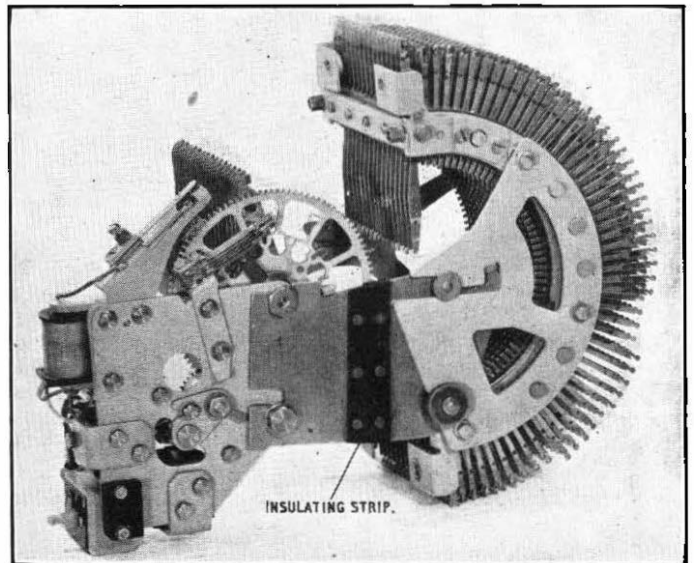

FIG. 5.—MECHANISM FITTED IN OUTRIGGER.

For convenience in placing marking conditions on groups of wires, or for other cross-connection purposes, a confection strip can be fitted alongside the bank and fixed to it. It consists of 26 flat tags in two groups, one of 16 tags and one of 10.

Ribbon Cable.

For commoning the bank contacts to form a multiple a special cable form has been introduced. Fig. 6(a) shows a portion of a typical form: the normal length consists of 10 "appearances" of the bared conductors.

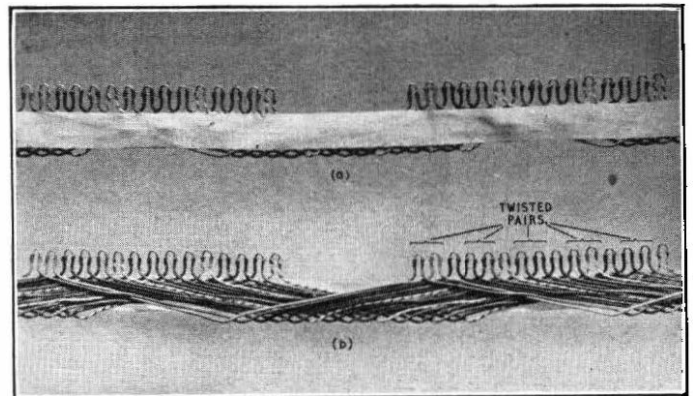

FIG. 6.—RIBBON CABLE USED FOR BANK MULTIPLE.

The form consists of double-cotton-covered wires held in position by two tapes of woven cellulose acetate secured to the wires by adhesive. The shape to which the wires are formed can be seen in Fig. 6(b) which shows a length of the cable with one tape removed.

Any number of wires from 1 to 16 can be made up into a form and any required adjacent pairs of wires can be twisted together, two half-twists occurring between each successive appearance. The colours of the insulation conform to the normal Post Office colour code.

The form fits between the rows of bank tags and is

separated from them by folded strips of non-inflammable cellulose acetate. The conductors are soldered to the inner notches of the tags by a mass soldering method.¹

Feeder Brushes and Collector Rings.

The feeder brushes are fitted at the top of the bank in the form of a separate assembly (see Fig. 4) consisting of 8 brushes. One of these assemblies is fitted to an 8-level bank and two to a 16-level bank. Each feeder consists of a single blade, to the end of which is riveted two splayed brushes, the tips being flared to permit the entry of the disc-shaped collector when the mechanism is offered to the bank (See Fig. 7).

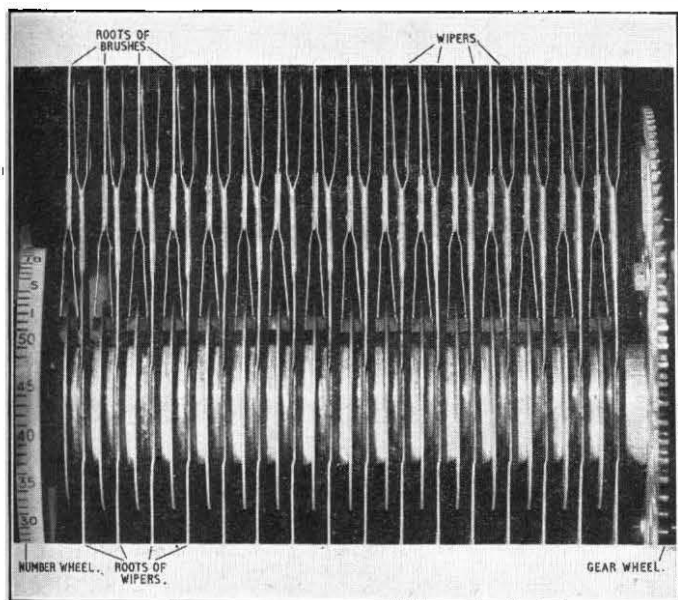

FIG. 7.—FEEDER BRUSHES AND COLLECTOR RINGS.

Wiper Assembly.

The wiper assembly and its axle are secured to the mechanism side plate (see Fig. 8). The complete mechanism assembly locates in the bank side plate so that the wiper

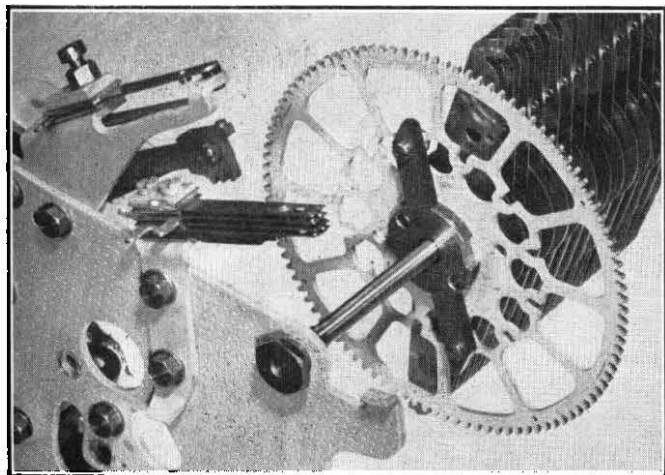

FIG. 8.—WIPER ASSEMBLY SHOWING FIXING OF AXLE TO SIDE PLATE.

axle is concentric with the bank contacts. The end of the axle remote from the mechanism is steadied by fitting into a hole in a V-shaped bracket attached to the bank. This bracket also carries a pointer alongside which the number

¹ Grinstead, W. H. "The Motor Uniselector and the Technique of its Application in Telecommunications." *Proc. I.E.E.*, Part III, No. 43, page 406.

wheel rotates. The wipers, collector discs, insulators, spacers and the collar to which the number wheel is screwed are assembled on a hub of high tensile steel, from which they are separated by an ebonite insulating bush. The whole is clamped together under pressure by manganese bronze nuts screwed to each end of the hub. These nuts also serve as bearings for the rotation of the assembly on its axle, which is of stainless steel. One of the bearings has two projecting stainless steel pins which locate the gear wheel, and also four slots, machined to a considerable degree of precision, into which the cams are fitted. From Fig. 7 it will be seen that the feeders are offset slightly in the direction of their respective wipers; this ensures that any false contacts which might occur between wipers and feeders due to vibration of the wiper tips are only between pairs which are already electrically connected.

To simplify manufacture and to avoid the introduction of an excessive number of different uniselector codes, it was decided during development that switches would only be made in sizes of eight and sixteen levels.

For ease of assembly double-ended wipers are made up of two single-ended wipers, suitably set so that the tips are in line; this set can be seen in Fig. 7.

Transmission.

The drive from the armature to the wiper assembly is transmitted via an idler gear. This consists of two concentric mild steel gears running on a nickel silver spindle through which passes a lubricating wick. The overall gear ratio is 26 : 1 and, as the wiper assembly gear wheel has 104 teeth, $\frac{1}{4}$ of a revolution of the armature steps the wipers from one contact to the next. Adjustments are provided to vary the depths of engagement of the idler gear with both the armature and the wiper gears; by this means backlash can be controlled and smooth and silent running ensured.

Latch.

The latch assembly consists of an electromagnet which, on energisation, attracts a pivoted armature to which is attached the latch detail consisting of three teeth shaped to mesh with the gear wheel on the wiper assembly. When the uniselector is at rest the coil is not energised and the latch engages the wiper gear wheel. On operation of the magnet the armature is attracted to the core and the latch is lifted, thus freeing the wiper assembly. Towards the end of the armature stroke the tungsten contact on the back of the latch detail makes with the "fixed" contact and the motor circuit is completed. The "fixed" contact in this instance, is secured to a thick spring, which flexes slightly, allowing the contacts to rub against each other. This rubbing action is necessary to break down the high-resistance oxide film which forms on tungsten when exposed to the atmosphere.

To assist in a fast release of the armature on disconnection of the latch magnet circuit a 0.008 in. phosphor bronze residual stud is fitted.

The armature restoring spring consists of two adjacent flat springs in order to reduce the internal stresses caused by the relatively large deflection. During the first portion of the movement on release the restoring spring is assisted by the "fixed" contact spring. A screw adjustment is fitted for varying the tension in the restoring spring, which is kept as high as possible compatible with full operation of the armature under all conditions.

In order to minimise the effects of shock on engagement of the latch, the latch detail is fixed to the armature by two bowed springs. The spokes of the wiper gear wheel also possess resilience to assist in absorbing the kinetic energy of the moving parts.

The latch magnet coil, which has a resistance of 100 ohms, consists of 3,400 turns of 0.0076 in. enamelled copper wire.

Cam Springset.

The cam springset which can be seen in Fig. 8 consists of four springs, forming one make and one break action. Springs 1 and 2, which are broken when the wipers are standing on the "home" contacts, control the latch magnet. (Spring 1 is nearest to the wiper spindle.) The other contact action can be used in external circuits.

Fig. 9 shows the stages of operation of the springset.

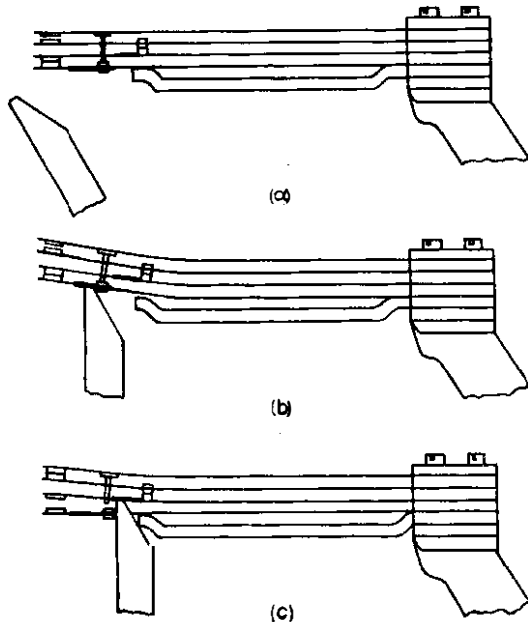

FIG. 9. --STAGES IN OPERATION OF CAM SPRINGSET.

As the wipers approach the "home" contact, the cam on the gear wheel engages the lug on spring 1, thus tensioning all the springs without altering the relative positions of the contacts (Fig. 9(b)). As soon as the wipers leave the contact preceding the "home" contact the cam moves away from the lug on spring 1 and supports the lug on spring 2, allow-

ing springs 1 and 4 to restore, thus breaking the latch magnet circuit and completing the external circuit (Fig. 9(c)).

The "two-stage" operation of the springset results in a clean action, the actual timing being substantially independent of contact openings and spring tensions.

The contacts on all the springs are of platinum: a spark quench consisting of a 0.5 μ F capacitor in series with a 200-ohm resistor is fitted across springs 1 and 2.

ADJUSTMENTS

It is not proposed to discuss adjustments of the uniselector in detail; the following points may, however, be of interest.

Most of the adjustments can be carried out with the mechanism fitted in an outrigger, as shown in Fig. 5. The outrigger is made in three sections, the centre section being of insulating material. The mechanism is not, therefore, connected to earth when in the outrigger and the wipers may be moved away from the "home" position without completing the "homing" circuit.

To facilitate the adjustment of the cam springset four small holes are drilled near the periphery of the main gear wheel: these identify the "home" positions when the mechanism is out of the bank and serve to locate the adjusting tool.

Adjustment of the position of the motor magnets, and the pillars which support the yoke and the interrupter assembly is carried out by means of a cylindrical gauge which mounts on the spindle in place of the rotor.

To enable the uniselector to be run without completing the external controlling circuit a hand-operated test spring is provided which earths the latch magnet.

ACKNOWLEDGMENTS

The author wishes to record appreciation of the assistance given by Messrs. Siemens Brothers & Co., Ltd. in the preparation of illustrations and to acknowledge help and criticism given by colleagues in the Engineer-in-Chief's Office.

Book Review

"Radio," Vol. 1. J. D. Tucker and D. F. Wilkinson. The City and Guilds Series, published by the English Universities Press, Ltd. 177 pp. 152 ill. 7s. 6d.

This book is the first of three volumes that are intended to cover the requirements of the Radio syllabus of the examinations of the City and Guilds of London Institute; Vol. 1 covers the syllabus of the Grade I Radio Examination and also part of that for the Radio Amateurs Examination.

The scope of Vol. 1 is indicated by the chapter headings, which are as follows: Electricity and Magnetism, Radio Communication (principles), Aerials and Tuning, Components and Valves, Audio Frequency Amplifiers, Radio Frequency Amplifiers, Power Supplies, Oscillators, Modulation and Detection, Receivers and Measurements in Radio Work.

In view of the relatively wide field covered, and the purpose of the book, the treatment is necessarily brief and at an elementary level. The authors have, it is considered, made an attempt to meet the needs of students who are new to the subject of radio. They have not neglected the practical aspects of the subject and they have endeavoured to present their material in a clear and interesting manner.

Unfortunately, Vol. 1 contains a number of inaccuracies that would certainly lose marks if reproduced by students in their answers to examination questions. For example, on p. 43 the

equivalent circuit of a vertical wire is shown as a parallel-tuned circuit; in fact such an aerial behaves as a series-tuned circuit, since at low frequencies it approximates to a capacitor and not to an inductor. The diagram, Fig. III 7, on p. 39, gives an incorrect impression of the effect of Q on the selectivity of a tuned circuit. The response of the low- Q circuit off frequency is shown as being greater than that of the high- Q circuit, whereas the reverse is the case; furthermore, such response curves should approach the frequency axis asymptotically and not abruptly as in the figure. Fig. IX 13, on p. 143, which purports to show anode-bend detection, is misleading; such a detector uses the nearly square-law portion of anode-current, grid-voltage valve characteristic, whereas the diagram shows an abrupt change of anode current with grid voltage at the operating point. Fig. IX 12, on the same page, shows a bias battery in series with the tuned circuit, which would have a disastrous effect on the Q of the circuit. The oscillator circuits given in Figs. VIII 6 to 9 unaccountably include battery bias as well as self-bias RC grid circuits. A more serious error occurs on p. 153 where it is said that the combination of two waves of 90 and 100 kc/s is "exactly like that which we should produce if we modulated a carrier with a 10 kc/s note"; this is not so the linear addition of two waves does not amount to modulation.

Before this book can be recommended for general use by students it is highly desirable that the inaccuracies mentioned above, and others that are present, be corrected.

I.P.O.E.E. Library No. 2069.

W. J. B.

The Filtered Engineering Fault Complaint and Repair Service

B. H. BERRESFORD
and J. MARTIN†

U.D.C. 621.395.365

This article describes a modified ENG scheme in which subscribers' calls are filtered through a monitorial suite to distinguish between engineering complaints and service difficulties; the monitor then connects the subscribers as required. Initially, the scheme applies only to subscribers on non-director exchanges situated in areas where the relevant maintenance control includes three or more test positions.

Introduction.

FROM time to time, telephone subscribers require to make complaints or to seek advice about various aspects of the service. The simplest arrangement for the subscriber, would be to refer all such complaints or enquiries to a central point, at which attention could be given. It is not practicable, however, to staff such an enquiry bureau with experts on every aspect of the service, but several alternative arrangements, of which the following have been used by the Post Office, are possible. The subscriber can be given separate dialling codes or telephone numbers for each of the services he may wish to consult; he can be advised to route all enquiries to a central point at which records of them can be made for subsequent attention, or from which he can be extended to the appropriate expert; or a combination of these schemes can be used.

Fault Reports.

So far as fault reporting is concerned it has been the practice hitherto, in most non-director automatic areas, for subscribers to dial "91" and for the assistance monitor to record their troubles on dockets for subsequent attention by the maintenance control staff. This is the simplest procedure for subscribers because, in these areas they also dial "91" when wishing to make complaints and enquiries about other aspects of the service. However, it has distinct disadvantages from engineering considerations. Delay must inevitably occur between the receipt of the subscriber's complaint and the first engineering test of the circuit alleged to be faulty. The monitor, having very limited engineering knowledge, is not likely to obtain from the subscriber, who, in general, will also have little technical knowledge of the working of telephone systems, an accurate account of the trouble experienced and will not, in any event, be able to convey, in a few brief words on a docket, all of the information obtained.

An attempt was made to overcome these objections by the introduction of the Engineering Fault Complaint and Repair Service in London in 1931 and its subsequent extension to Birmingham, Manchester, Glasgow, Edinburgh, Newcastle and Leeds. With this procedure, subscribers wishing to report faults on their installations are requested to dial "ENG" in director areas, or "97" in non-director areas, and are routed direct to the complaints positions of the maintenance control. On the other hand, subscribers wishing to report service difficulties or make complaints or enquiries about other aspects of the service are required to dial "0" in director areas, or "91" in non-director areas. The engineering officer, being able to refer to the previous fault history of the circuit and, if necessary, to test it when the report is made, can form a much better idea of the nature of the fault and its probable cause than is possible by reference only to the details of a fault report on a fault docket. Apart from the advantages which this arrangement gives the engineering staff, the subscriber is impressed by his particular trouble receiving individual, expert attention.

Further, the transit time of a docket is eliminated and subsequent reference to the subscriber for more detailed information, often necessary under the docket system, is obviated.

As so often happens, experience has proved in practice that, although the scheme has desirable features it also has certain marked disadvantages. The chief of these is the inability of the subscriber to distinguish between service difficulties, which should be dealt with by the operating staff, and troubles which are proper to the engineering staff, with the result that both engineering and operating staff deal with many wrongly routed complaints. There is also the difficulty of providing adequate engineering staff to cope with the short-duration peaks of complaint traffic without an undue wastage of staff and test desk equipment during the slacker periods. These factors are largely responsible for the poor speed of answer sometimes obtained on the complaint lines.

Consideration of the advantages and disadvantages of the docket and ENG systems of fault reporting led to the development of a new procedure having the main advantages of both whilst avoiding their principal disadvantages. Initially, the new procedure will be applied only in non-director areas.

The New Procedure.

In the new procedure all complaints are referred in the first instance to the monitorial suite, i.e. by dialling "91." After quickly deciding the nature of the complaint the monitor extends, over special complaint lines to the maintenance control, those complaints which are proper to be dealt with by the engineering staff. This enables the engineers to obtain first-hand information of the trouble and gives all of the other advantages associated with the full ENG scheme. The new procedure has the advantage over the full ENG procedure, that the operator can regulate the flow of complaints to the engineering staff to suit the number of engineers who are available to deal with them. This is done by limiting the number of complaint lines available for use to the number of complaint officers available to answer them. Complaints received by the monitor when all complaint lines are engaged are recorded on dockets for subsequent attention by the maintenance control staff. The procedure has come to be known as the "Filtered Engineering Fault Complaint and Repair Service" or, in brief, "Filtered ENG."

An obvious criticism of the new system is that subscribers may object to repeating their complaints to an engineering officer, after having once made them to the monitor. This criticism has not been substantiated in practice; in fact, all comments received from the public in those areas in which the system has been on trial, have been favourable.

A further criticism might be that the time a subscriber has to wait before being able to make his complaint to an engineer is appreciably longer with the Filtered ENG than with the full ENG procedure. Analysis of the speed of answer at ENG centres and the time which elapses between the appearance of a calling signal on the monitorial suite and the ultimate answer by an engineer, at Filtered ENG centres, has produced the following results:—

† The authors are, respectively, Executive Engineer and Assistant Engineer, in the Telephone Development and Maintenance Branch of the E.-in-C.'s Office.

TABLE 1
Most frequently occurring waiting times for subscribers

FULL ENG	FILTERED ENG			
To answer by engineer	To answer by monitor	While monitor dealing	To answer by engineer	Overall time to answer
5 sec	2 sec	10 sec	2 sec	16 sec

(In this type of analysis it does not follow that the overall time to answer will be the sum of the individual most frequently occurring times. In fact, the overall time to answer which occurred most frequently with the Filtered ENG procedure proved to be 16 seconds.)

From Table 1 it can be inferred that the "average" subscriber gets an answer within 5 sec. with the full ENG procedure, but with the Filtered ENG procedure, after being answered by the monitor in 2 sec., the "average" subscriber has to wait a further period of 14 sec. before being answered by the engineer. Although the "average" subscriber reaches the engineer more quickly with the full ENG procedure, Table 2 shows that there are fewer

TABLE 2

Time from start of call	Percentage of subscribers answered within time stated		
	Full ENG	Filtered ENG	
	By engineer	By monitor	By engineer
10 sec	34%	80%	5%
30 sec	75%	95%	70%
60 sec	90%	99%	95%
120 sec	97%	100%	100%

"unfortunate" subscribers with the Filtered ENG procedure. It is probable, too, that most subscribers, having received a prompt answer from the monitor, do not mind waiting 14 sec. or so for the engineer, especially as the monitor will be talking to them for most of this time.

Facilities.

A new relay set for use on the complaint lines has been developed. Its facilities include a key for busying the circuit at the test desk when the officer concerned with that circuit is not available for receiving complaints, e.g. when co-operating with jointers on a cable breakdown or carrying out other special tests. In addition, during periods of abnormal complaint traffic, such as occur after storms or following a large cable-breakdown, all complaint lines may be busied and arrangements made with the supervisor for subsequent complaints to be docketed, thereby enabling the maintenance control officers to give their full attention to a speedy restoration of the service. It would, of course, be undesirable to busy all complaint lines without first advising the supervisor, but such advice should not be necessary when only a small proportion of the lines are busied.

A recall facility is provided for use when it is necessary to bring the operator back into circuit.

To give the officer in charge of the maintenance control a measure of control over the complaint lines a beacon pilot lamp is provided, which glows when all complaint lines are engaged or busied out. When this occurs he is able to open another position, staffed by himself if necessary, if one has been closed or a spare one exists. It may also serve as an advance indication of an abnormal flow of complaint traffic, investigation of which may prove the existence of a cable breakdown and the need, temporarily, to close down the Filtered ENG service.

A pilot cut-out key is provided for use when all complaint lines have been busied out.

One complaint line with busying key, recall key and calling lamp is provided to each test position used wholly

or partly for subscribers' line testing, but not to positions used exclusively for Advice Note work or as trunk and junction test positions. Additional appearances of each line with calling lamps and recall keys but without busying keys, are provided as required. In small controls with not more than four testing positions it is found convenient to provide appearances of all lines on all positions, but with only one busying key for each line. In larger controls the provision of additional appearances depends on the way in which the maintenance control area is divided between the maintenance control officers. These arrangements should enable an immediate answer to be given by the maintenance control staff on the complaint lines.

Organisation of the Maintenance Control Area.

The most satisfactory way of arranging the work of the maintenance control area is to split it up into well-defined sections which can be readily identified by the nature of the numbering scheme or by the exchange names. Each maintenance control officer is made responsible for dealing, as far as possible, with the subscribers' complaints from one or more sections and for arranging for the orderly clearance of the faults found. This is preferable to having separate complaint and fault distribution officers, because one man is thereby made responsible for receiving a complaint, diagnosing the trouble and organising its clearance.

In the larger centres it is not practicable for one man to deal with the complaints received from all of the subscribers in the main exchange area, but two or three officers working as a team can share the responsibility.

The complaint lines are labelled, on the manual board, in some distinctive way to indicate, to the operators, the sections of the area with which each maintenance control officer, or group of officers, is concerned, so that, as far as possible, complaints may be extended to the appropriate test position.

Extent of Application of the Procedure.

The present intention is to limit the new procedure to maintenance control areas in which the controls have three or more test positions. In general, such an area has not less than 6,000 exchange connections (say, 10,000 stations) which can be tested from the maintenance control. Analysis of fault complaints at smaller centres indicates that although the total number of complaints received during the day is small, being roughly in proportion to the size of the area, two or more complaints are frequently received at the same time. As the maintenance control officers must attend to the normal business of the control and in particular must deal with the external faultsmen, they would often be unable to cope easily with the complaint traffic. In short, the organisation of a maintenance control having less than three testing positions is insufficiently flexible to enable the Filtered ENG procedure to be worked efficiently. Moreover, a much lower percentage of subscribers' lines can be tested from such a control, owing to the larger proportion of small manual exchanges and U.A.X.s in these areas, than is possible at the larger controls, and it would appear that little advantage would be gained there by introducing the procedure.

The Scheme on a National Scale.

Of all subscribers at present connected to automatic exchanges 52 per cent. are served by the full ENG procedure, 26 per cent. will use the Filtered ENG scheme as at present planned and 22 per cent. will continue to have their fault reports recorded by the monitor as in the past. Hence 78 per cent. of all subscribers on automatic exchanges will have access to the maintenance control when reporting

faults. Whilst it will not be possible for the maintenance control officers to test the lines of all of the additional 22 per cent., it might be an advantage, in spite of what has been said in the previous paragraph, for the engineers to have first-hand information of subscribers' troubles and it may be desirable later to consider the inclusion of such exchanges in the procedure. In addition, the extension of Filtered ENG to director areas, although not at present planned, may be worthy of consideration later, but further experience of the operation of the procedure will be required before a final decision on both of these points is taken.

Finally, about 28 per cent. of all subscribers' stations are connected to manual exchanges. Of these a large proportion will come within the scope of the new procedure when the exchanges are converted to automatic working.

The Procedure in Operation.

It is intended, initially, that fault reports from subscribers connected to manual exchanges or automatic exchanges to which centralised testing facilities from the maintenance control cannot be provided, should continue to be recorded on dockets by the monitorial staff. In addition, dockets will be prepared for reports of exchange faults observed by the operating staff; reports in respect of accommodation plant; reports of faults thought by the operating staff to exist after attempting to connect a subscriber who has complained of difficulty in obtaining a particular number, e.g. wrong number, no ring tone and permanent engaged-tone reports; fault reports in respect of call offices (but not those made from call offices in respect of private installations) and those received outside normal hours of engineering duty or when all complaint lines are engaged.

It has been estimated, in an analysis of complaints made during the trial of the procedure, that about 25 per cent. of all fault reports from the exchange areas in which the procedure is operated, i.e. excluding manual exchanges and automatic exchanges without centralised testing facilities, will be recorded on dockets. The proportion of dockets prepared for the various reasons were as indicated in Table 3.

TABLE 3

	Faults reported by operators	Reports in respect of call offices	Miscellaneous items	Reported outside normal hours of engineering attendance	Reported when all complaint lines were engaged
Percentage of reports docketed	34	22	31	9	4
Percentage of total reports	8.5	5.5	7.75	2.25	1

From this it will be seen that only 1 per cent. of all fault reports were docketed because all complaint lines were engaged. As only 2.25 per cent. of the total reports were received outside the normal hours of engineering attendance it is not worth providing an all-night Filtered ENG service, particularly as, except for attention to subscribers on the emergency list, the faultsmen do not work at night.

It would perhaps be possible to reduce the number of faults reported by the operators by arranging for all service difficulty complaints to be referred immediately to the engineering staff, but it is considered preferable for the operators to complete the subscribers' calls even though, by so doing, the chance of tracking down an exchange common equipment fault is missed. Also it would be unreasonable to delay the completion of calls by connecting to the test desk call-office users who have dialled "0" because of difficulty or to report call office defects.

If the procedure is to meet with the approval of subscribers it is essential that the speed of answer on the complaint lines should never be more than a few seconds. This is possible if proper use is made of the busying keys and the maintenance control staff are adequately supervised, led and encouraged.

Conclusions.

The introduction of this procedure, which enables direct contact to be made between the engineering staff and the subscribers and which thus stresses the responsibility of the maintenance control for ensuring the speedy and effective clearance of faults, provides a more efficient service to the subscriber and should make control work more satisfying.

Book Review

"Britain's Post Office." Howard Robinson (foreword by the Postmaster General). Oxford University Press. 300 pages. 29 ill. 21s.

When it is realised that the practice of letter carrying dates back to the reign of Henry VIII, as revealed in the famous letters of the Paston family, the relatively small part the telephone and telegraph services play in the history of the Post Office is perhaps not surprising. This Post Office history is therefore largely the story of the mails, with short references to the other important services now carried by the Post Office.

It will be of interest to readers of this Journal to record that the first mention of the Engineering Department does not occur until about three-quarters of the way through the book. Apparently in 1850 there were four engineers listed in the Establishment Book of the General Post Office; two for the "lifting machine" and two engineers for "gas." A footnote reveals that the Engineering Department as such was set up in 1870 when the telegraphs were taken over. The first commercial wireless telegraph station of the Post Office was

opened at Bolt Head in Devon in 1908, and it is rather amusing to read that its opening "added greatly to the importance of the Engineering Department." By 1880 the Engineering Department had a "large" staff of 600, including a stores department and some 300 linemen!

The main theme of the book is, however, the growth of the postal services and the gradual evolution from the early days when their principal object was the carriage of the Royal despatches and later to provide a convenient source of income at the personal disposal of the Crown, to the gradual evolution of the efficient public service which we know to-day. The story passes through the phase of the mail-coach when many believed it was tempting providence to travel at nine miles an hour, and relates how Chief Justice Campbell took his first journey by mail-coach despite warnings by friends that such speeds were "highly dangerous to the head independently of the perils of an overturn." The first use of envelopes, adhesive stamps, the introduction of uniform postage, the coming of the railways, steamships and the story of the foundation of the Cunard Line to provide a mail service between Halifax and Liverpool are among the many facets of this very interesting tale of the history of the postal services. H. F.

A New 10-cwt. Utility Vehicle

G. H. SLATER, A.M.I.E.E.†

U.D.C. 629.113

This article describes a new 10-cwt. Utility vehicle for use on external construction work in circumstances where the standard 1-ton Utility vehicle is unnecessarily large. The new vehicle is a Morris Commercial "J" type as used in the postal fleet, but modified to meet engineering requirements.

Introduction.

THE present standard 1-ton Utility vehicle was introduced as a result of a recommendation of the Committee on Engineering Transport Efficiency in 1935. The recommendation was to abandon the then existing 1-ton General Utility vehicle, and to incorporate some of its features in the 1-ton Jointer's vehicle which would then serve as standard for 2-men or 3-men working parties including jointers. At the same time the 15-cwt. Jointer's van, the 15-cwt. Fitter's van and the 10-cwt. Trojan van were withdrawn from engineering use; thus five individual types of vehicle were merged into one.

Except for comparatively minor modifications the 1-ton Utility vehicle (Fig. 1) has served for nearly 20 years,

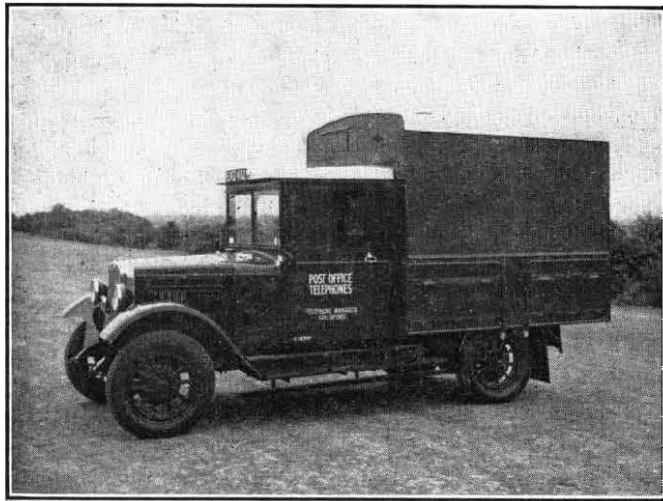

FIG. 1.—THE 1-TON UTILITY VEHICLE.

covering a wide range of duties for overhead, underground and installation parties, and is a tribute to the wisdom of those who made the decision and to the designers of the original vehicles. Because of the facilities incorporated in its design to meet the varying requirements of the duties involved, the vehicle is, of necessity, much larger, heavier and more expensive than one with a less extensive range of use, and it is inevitable that many of the facilities provided, e.g. for carrying a long ladder and wiring drum, may never be used. Certainly many such vehicles never tow a trailer.

At the present time the engineering fleet includes approximately 1600 1-ton Utilities (about one tenth of the fleet), and it was considered that the number was sufficiently large to justify a review of the situation with a view to reducing motor transport costs and securing other advantages.

It should be mentioned that during the war the 1-ton Utility could not be obtained; accordingly the 8-cwt. van type I was in many cases used as an alternative. In spite of its limitations this smaller vehicle proved reasonably suitable for many two-men parties where the longer types of ladder were not required, and in fact many of these vehicles are at present in use by jointer's although the housing of the tents presents a problem which cannot be

entirely overcome. However, the vehicle has some advantages over the 1-ton Utility particularly in respect of size which is of importance in the more congested town areas

Morris Commercial "J" Type 10-cwt. Van.

In considering the use of standard commercial types of vehicles in the Engineering Department it is of course necessary to take into account the wider field of transport usage in the Post Office as a whole and, since the postal fleet is almost as large as the engineering fleet and provision and maintenance is concentrated under the control of the Engineering Department Motor Transport Branch, the use of a standard commercial type of vehicle for both engineering and postal use offers obvious advantages.

With the introduction of the "J" type Morris van to the postal fleet as a replacement for the 100 cu.ft. van, which was of course commercially the same type as the engineering 8-cwt. van type I, the Construction Branch was asked to consider the use of this vehicle for engineering purposes.

At first sight the Morris "J" did not appear particularly attractive; the vehicle was unsuitable for a ladder carried on the roof, firstly because the roof was rather high, and secondly because there was a possibility of instability with a ladder mounted in that position. It was decided, however that by limiting the maximum size of ladder to be carried to that of a Ladder, Extension No. 5, which is 8ft. 4in. in length (closed), it would be possible to house the ladder on the floor of the vehicle, an arrangement which offered considerable advantages in both vehicle stability and ease of loading, unloading and securing the ladder. Further, at this stage it was decided that the vehicle not only offered advantages as a superseding type for the 8-cwt. van type I but also had distinct possibilities as a superseding type for many 1-ton Utilities.

A standard Morris Commercial "J" type 10-cwt. van was therefore made available by the Motor Transport Branch for modification to produce a prototype engineering vehicle.

The "J" type 10-cwt. van for postal work can be readily recognised by the prominent feature of the sliding door. This feature offers obvious advantages in both use on the roads and in garaging space, in that it provides adequate openings for entering and leaving the cab on both near side and off side without any of the disadvantages associated with the sweep of the door necessary in the hinged type and, although the doors of a postal van may open many more times in a day than the engineering counterpart the introduction of the sliding door to engineering vehicle will undoubtedly bring distinct advantages in use on the job and in garaging.

Modifications to meet Engineering Requirements.

The engineering version of the Morris Commercial "J" type 10-cwt. van is illustrated in Fig. 2, which shows clearly how the distinctive lines of the vehicle have been retained free from all additional external fittings. The vehicle illustrated is fully loaded carrying a jointer's kit complete with four tent sections, a 20-ft. extension ladder, motor pump and lighting set.

In carrying out the modifications, the housing of the ladder presented some difficulty as it required a space free from obstruction at least 8ft. 4in. long by 20in. wide by 8in. deep. The obvious solution was a false floor (Fig. 3) which was

† Executive Engineer, External Plant and Protection Branch, E.-in-C.'s Office.

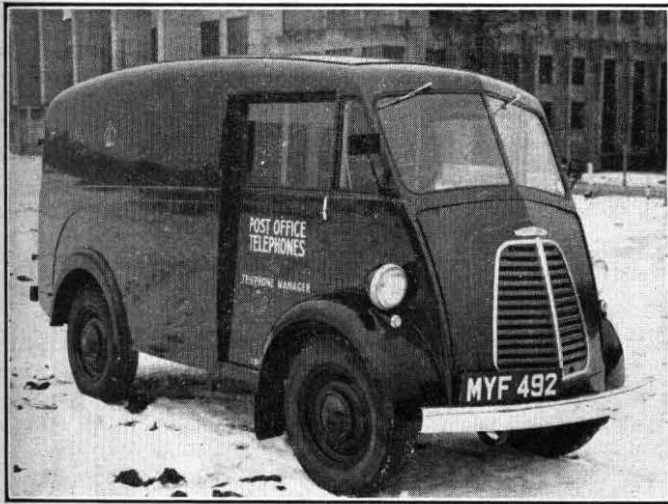

FIG. 2.—THE NEW 10-CWT. UTILITY VEHICLE.

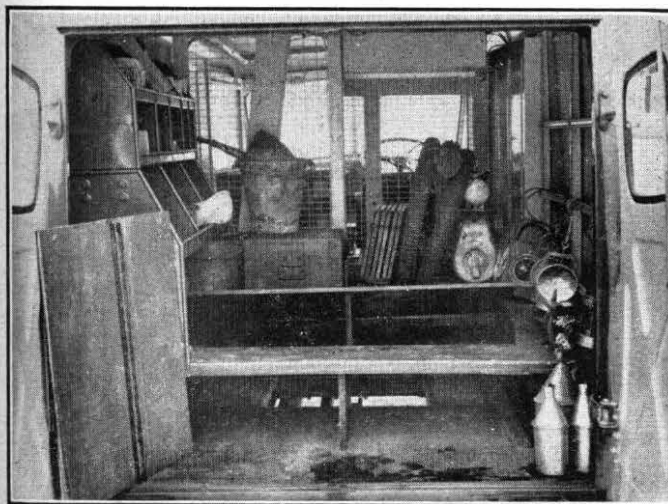

FIG. 3.—DETAILS OF CONSTRUCTION OF FALSE FLOOR.

mounted on two light gauge (16 S.W.G.) channels specially pressed and fitted with bracing webs and feet drilled to coincide with the existing floor-chassis anchoring bolts. The lower flange of the near-side channel was shaped at the forward end to give access to the petrol gauge potentiometer fitted to the petrol tank. The false floor itself was designed in three sections laid in light gauge $\frac{1}{2}$ in. angles arranged transversely and welded to the main channels. The centre section of the floor is removable to give access to the back axle via the original trap in the main floor of the vehicle. A partition disposed vertically between the two floors was arranged in three sections, the forward and rear fixed and the centre section fixed only to the underside of the removable section of the false floor, to provide a tunnel of the dimensions required to house the ladder. The lower edge of the centre portion of the partition was housed in a light U-shaped channel to provide a secure fixing when the removable floor section was placed in position.

The forward end of the ladder when in the tunnel extends to a position immediately below the driver's seat; the Morris Commercial seat was, therefore, removed and replaced by a Departmental standard seat mounted on steel bearers, with a sheet steel panel to form a front stop for the ladder. The near side of the seat mounting was left open to give access to the ladder from the front end should this at any time be necessary, and the off side was partly screened to ensure unobstructed access to the off side step. The seat is adjustable forwards and rearwards in

the usual manner and is of the same height, and in exactly the same position as the Morris Commercial standard seat.

To facilitate the housing of the tent sections and to provide a comfortable passenger seat, the wire mesh screen has been stepped. This allows the passenger seat to be set back and, by partly covering the step well, adequate leg room for the passenger and an easy step from the near side of the vehicle are provided. Both steps, near side and off side, are therefore alike, and access to either seat is possible from either side of the vehicle. Further, there is possibly an advantage in the setting back of the passenger seat in that the driver's view when looking to the left is less likely to be obscured by the passenger.

The fitting of the false floor necessitated the repositioning of the vehicle battery, which in its normal position under the main floor of the vehicle on the off side, would have been inaccessible because of the false floor supports. It was, therefore, removed and repositioned under the passenger's seat, where ready access to the battery and master switch is available by simply tipping forward the passenger seat on its hinged mounting. Also, part of the space available under the passenger seat has been profitably used for stowing the smaller vehicle tools in a lock-up compartment.

To provide lock-up accommodation for the books and papers necessary for the Department's work, a locker is incorporated in the upper portion of the wire mesh screen immediately behind the driver. This locker has two sliding doors and is partitioned to provide two compartments.

A table was designed to be easily removable when major maintenance is necessary to the engine, and to fold back with the engine cover to give ready access to the engine for normal maintenance operations. The table top also folds on itself, and when the hinged flap is brought forward it provides a writing table, or if desired a meal table. This table fits into the space immediately above the engine cover (Fig. 4), being secured in position on hinged brackets fitted just below the near side wind screen and supported on a folding leg, the lower end of which fits into a slot in the engine cover. The hinged flap of the table top is additionally supported, when open, by two sliding arms housed on the under-side of the fixed half of the table.

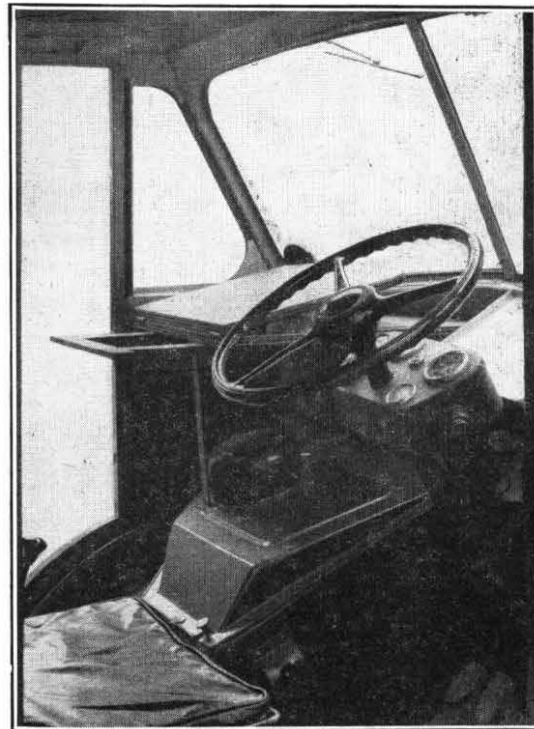

FIG. 4.—VIEW INSIDE DRIVING CAB SHOWING THE WRITING TABLE.

The fittings inside the body are simple and consist of two bins mounted one above the other as compartments on the near side of the vehicle, providing accommodation for small items of stores and tools.

The underfloor space on the near side can, if necessary, be used to stow digging tools, a pair of five-tread folding steps, pruning rods, tent seats and stretcher bars, and tarpaulins, according to requirements. The space immediately behind the near-side underfloor space conveniently accommodates a joiner's toolbox.

A typical layout of tools, stores and equipment, in which a joiner's kit with motor pump and lighting set is included, is shown in Fig. 5.

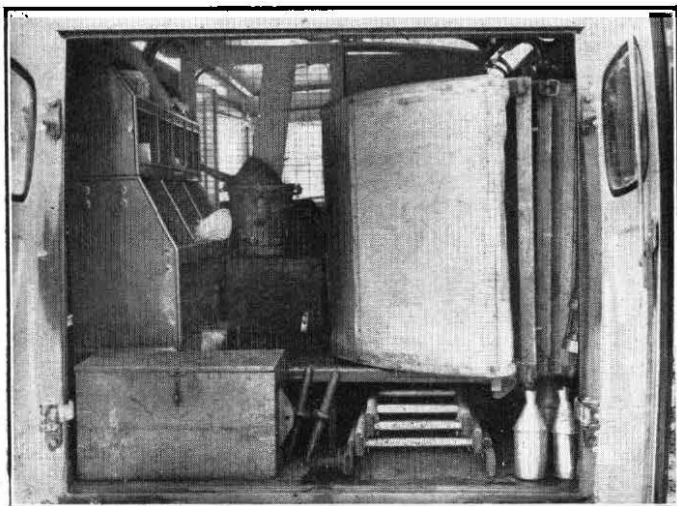

FIG. 5.—TYPICAL LAYOUT OF EQUIPMENT IN VEHICLE.

Two lights inside the vehicle, one in the body and one in the cab, controlled by a switch beside the driver's seat, provide artificial light, and two coat hooks on the screen behind the passenger seat complete the internal fittings.

The rear bumper bar has been arranged for the attachment of a towing hitch for the purpose of occasionally towing a trailer tool cart, which is well within the capabilities of the vehicle. Towing is confined to trailer tool carts only, and it has, therefore, been decided that the towing hitch shall only be fitted on request when it is considered essential to provide the facility.

Book Review

"Introduction to Electronic Circuits." R. Feinberg, Dr.-Ing., M.Sc. Longmans, Green & Co. Ltd. 163 pp. 128 ill. 18s.

This book is based upon a lecture and laboratory course given to students in the University of Manchester and is intended primarily for university undergraduates attending an introductory course in electronics. The author says in the preface that he has chosen the line of approach to the subject so as to prepare the student to understand any type of electronic device and its application in electric circuit technique; devices which rely upon transit time for their operation are not included. Each of the eight chapters is modelled upon the following basis of exposition: (1) description of the physical structure of object, (2) explanation of the mechanism of its action, (3) translation of the mechanism of action into mathematical terms, (4) deductions which can be drawn as a first

Conclusion.

As a vehicle to supersede the 8-cwt. van type 1, the 10-cwt. Utility vehicle is undoubtedly an improvement and may displace many 1-ton Utilities. During the experimental work on the development of the prototype vehicle, the whole contents (including motor pump and lighting set) of a 1-ton Utility used by a pair of joiners was transferred to the new vehicle and, when weighed and an allowance of 3 cwt. made for driver and passenger, was within the maximum weight of 1 ton 15 cwt. 0 qrs. permissible for vehicle and load. The total weight of vehicle and load including driver and passenger is approximately $\frac{1}{4}$ ton less than the unladen weight (2 ton 0 cwt. 3 qrs.) of the 1-ton Utility. The annual charges on the 10-cwt. van (including running costs) are approximately 25 per cent. less than for the 1-ton Utility vehicle.

On present-day costs it may sometimes be possible to justify the use of such a vehicle in place of a trailer tool cart, considering the manhours lost on divergent journeys and in waiting to be picked up, which often occurs when two parties are at work, one with a trailer tool cart being dependent on another with a 1-ton Utility. Here two Morris "J's" may well provide a more economic arrangement as well as bringing the not inconsiderable advantage of complete and independent mobility to both parties.

In garaging space the vehicle also offers some advantages in that it is estimated that three of these vehicles can be garaged in the space required for two 1-ton Utilities, a factor which is of appreciable importance in these days of restricted garaging space.

It is emphasised that the vehicle is not intended to supersede the 1-ton Utility as a type generally. It cannot do this. If it is necessary to carry a ladder longer than the Ladder, Extension No. 5, or a pay-load greater than 10 cwt. including driver and passenger or additional passengers, the vehicle is unsuitable.

Acknowledgments.

It is desired to record acknowledgments to Mr. J. J. Edwards, London Telecomms. Region (who was a member of the Committee on Engineering Motor Transport Efficiency referred to at the beginning of this article); to the Motor Transport Branch, and in particular the staff at Kidbrooke Repair Depot and Wembley, for their co-operation in the vehicle modifications; to the L.T.R. North-West Area, for facilities provided in that area; and to the author's colleagues who co-operated in the development of the new vehicle.

approximation, (5) directions for experiment, (6) numerical problems, (7) further reading.

Chapters 1 and 2 deal with vacuum valves including the basic magnetron and the cathode-ray tube. Chapter 3 deals with A.C. amplification and includes both positive and negative feedback. Chapters 4, 5 and 6 deal with non-linearity effects of vacuum-valve characteristics, sinusoidal oscillators and relaxation oscillators respectively. Thermionic gas-filled valves are dealt with in Chapter 7 and cold cathode valves in Chapter 8.

The vast subject of electronic circuits has been covered in 160 pages and of necessity it can only be an introduction. The text is in general very lucid and the diagrams clear. The main criticism is that the various parts have been given very unequal treatment, the most glaring example being nine pages devoted to the Inverter (a device for changing D.C. to A.C.) and only ten pages to all types of sinusoidal oscillators. One regrets that the author has not been more critical of the relative importance of the subject matter.

H. T. M.

Standby Generating Plant for the Manchester-Edinburgh Television Radio-Relay Link

R. C. MARSHMAN†

U.D.C. 621.396.68:621.313.12:621.397.24

The standby generating plant described in this article was designed to maintain automatic continuity of supplies at intermediate television radio-relay stations in the event of mains faults of more than two seconds duration. The plant is at its nominal voltage and frequency within seven seconds of mains failure and then takes over and remains on load until the mains supply is restored by remote control from a terminal station, or locally by a visiting officer. The condition of the plant is permanently indicated in both the intermediate and terminal stations and test runs can be started from either location.

Introduction.

TO maintain continuity of power supply to the intermediate stations on the Manchester-Edinburgh radio-relay link, it was necessary to provide standby power plant and, because of the isolated locations of the sites, it was specified that the plant should be capable of running for periods of one month without attendance. In these circumstances it was considered inadvisable to use continuously rotating fly-wheel start sets which would otherwise have been chosen to secure a practically uninterrupted supply. The control circuit was therefore designed to maintain supplies as near as possible continuously with normally stationary plant. It was also visualised that where the British Electricity Authority's overhead feeders are protected with automatic re-closing circuit breakers the supply would be liable to repeated restoration and failure. This, in conjunction with the necessary re-heating period for the radio-equipment valves, would have resulted in intolerable interruptions to the programme and account had to be taken of this in the design of the control circuit.

Facilities.

The plant was designed to give the following facilities:

- (a) Normal operation of the station from the public supply mains.
- (b) Monitoring of the public mains to detect excessive rise or fall of voltage (faulty mains) or complete failure.
- (c) Automatic starting of the engine if faulty mains persist for upwards of two seconds (this interval is adjustable) and switching of the standby supply to load when its voltage and frequency are normal.
- (d) Automatic starting of the engine immediately on complete failure of the mains, with switching to load when standby voltage and frequency are normal.
- (e) Local and remote manual push-button shut-down of the engine and switching of the mains to load at any selected moment after the mains are restored at normal voltage.
- (f) Automatic restoration of mains to load (even if the voltage is faulty) as soon as mains power is available in the event of the engine failing to start or shutting down due to failure during a run.
- (g) Local and remote push-button control to simulate a mains failure, for test runs on the plant.
- (h) Local push-buttons for starting and stopping the engine without switching to load; but if the mains fail whilst the set is running it will immediately switch to load.
- (i) Automatic safeguards to shut down the engine in the event of:—
 - (i) Excessively high cooling water temperature.
 - (ii) Excessively low lubricating oil pressure.
 - (iii) Excessively high frequency (governor failure).
- (j) Local signals at each intermediate station to indicate:—
 - (i) Mains contactor closed.
 - (ii) Standby contactor closed.
 - (iii) Engine locked out on failure to start.
 - (iv) Oil or water failure.

- (v) Maintenance attention when any control switch is left in other than its normal automatic position.
- (k) Remote signals at the control stations at Manchester and Kirk O'Shotts to indicate:—
 - (i) A.C. power—green for power available, red if no power available.
 - (ii) Power source—green for mains, red for standby.
 - (iii) Mains fault—green, normally; red, following a fault.
 - (iv) Mains condition—green when mains characteristics correct, red when faulty.
 - (v) Engine out of service—green, normally; red, if any control switch is left in other than its normal automatic position.
 - (vi) Fuel and water level—green for normal; red if either level is abnormally low.
- (l) Automatic re-charging of the starter battery whilst the standby set is running.
- (m) Adjustable refresher charge of starter battery whilst the mains are alive.
- (n) Automatic maintenance of fuel oil level in service tank.
- (o) Automatic opening of engine-room ventilation-louvres whilst the engine is running on load, and automatic closing of the louvres when the engine is stopped.
- (p) Complete isolation of the automatic cubicle, with mains feeding the load, for maintenance purposes.
- (q) A record of the total hours run by the engine at synchronous speed, and the total kW generated.

Notes on the Facilities Provided.

The power supply to the radio equipment is controlled by Ferranti automatic voltage regulators which will normally correct a variation of ± 10 per cent. in the input voltage. The degree of variation permitted on the mains before a fault is registered is thus normally ± 10 per cent., but this is continuously adjustable over a range of ± 25 per cent.

An adjustable interval of two seconds is allowed for a mains-voltage variation to persist outside the prescribed limits before starting the engine; this avoids unnecessary starts due to mains switching surges.

An assurance has been received from the B.E.A. that the frequency of the public mains will never be allowed to fall below 47.5 c/s and will not normally rise above 51 c/s. The radio equipment is not "frequency conscious" over this range and hence no monitoring of the mains frequency is required.

Once a mains fault has been detected, however, the engine will start and switch to load regardless of whether the mains are restored to normal during the starting interval. This avoids the possibility of a number of false starts being made due to repeated interruptions of the public supply of approximately five to ten seconds duration.

As the plant is to be unattended for long periods, facilities for remote starting and stopping for test runs whilst the mains are "good" were regarded as essential. This feature automatically provided facilities for controlling the instant at which the set would be shut down following the restoration

† Executive Engineer, Power Branch, Engineer-in-Chief's Office.

of the mains after a failure. It was thus possible to dispense with a battery-charge relay which would otherwise have been necessary to ensure that the set remained running for a sufficient time to re-charge the starter battery.

The remote "mains fault" signal is designed to change from green to red on the occurrence of a mains fault which should start the engine. It is only restored to green when the mains are deliberately reconnected by the remote controlling officer. The signal thus remains as a lasting indication to the controlling staff that a mains fault has occurred; if it is found that the "power source" signal is not showing red (i.e., "standby") in conjunction with the mains-fault red signal, the interpretation is that the engine has failed and arrangements must be made for maintenance attention to be given. It is impossible for the controlling officer to restore the mains to load until the phase-voltages are within the specified limits.

Circuit Description.

The basic circuit arrangement is shown in Fig. 1. The

further interval during which the engine can run up to speed before locking out the circuit in the event of failure start. When the engine fires and accelerates, the voltage generated by the battery-charging generator energises restart delay relay (RDR) which, in turn, disconnects engine relay circuit. The release lag of RDR ensures that the geared starter cannot attempt to mesh again whilst engine is coming to rest.

The standby supply, when available at normal voltage and frequency, energises the standby supply relay (SS) this forces the release of the mains contactor (even though the mains may have restored meanwhile) and completes the circuit for the standby contactor which closes and extends the standby supply to load.

When the mains are again available at normal voltage the voltage across points XX restores the remote main condition signal to green. Relay MRR can then be operated, in turn operating MVCR, one contact of which releases SR; SR will then open the starting circuit and close the automatic stopping circuit. The output of the battery

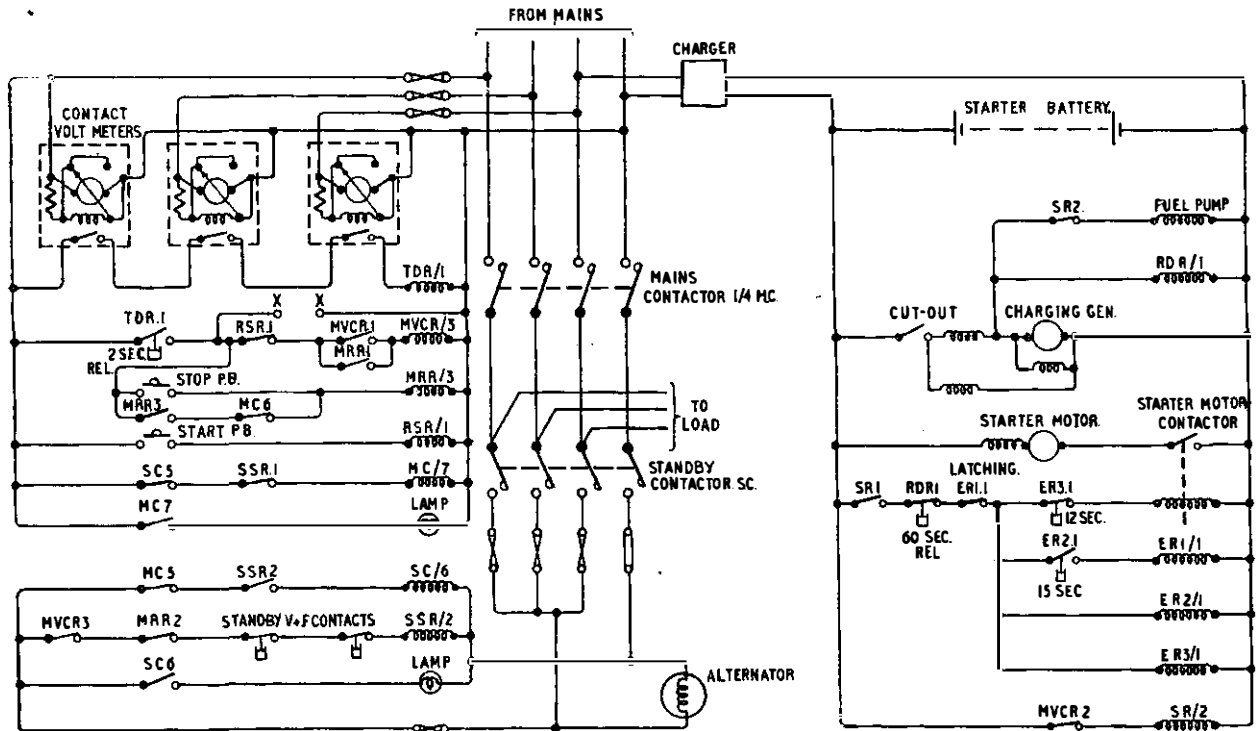

FIG. 1.—BASIC CIRCUIT ARRANGEMENT.

circuit was designed to incorporate the results of experience gained on the power plant provided for the London-Birmingham radio link and also incorporates features covered by Messrs. Ruston & Hornsby's patent number 454226.

The operation of the mains restoration relay (MRR) under push-button control operates the mains variation control relay (MVCR), which remains energised through its locking contact so long as the mains are alive at normal voltage. Variation of the mains outside the prescribed limits short-circuits the instrument relay of the contact voltmeter and releases MVCR via an interposed time-delay relay (TDR); MVCR is released immediately on a complete failure.

The release of MVCR prepares a circuit for the starting relay (SR), the contacts of which complete the circuit to the starter motor contactor and the engine relays (ER) and disconnect the automatic stopping circuit. The three engine relays time the starting interval, disconnecting the starting circuit after approximately 12 seconds and allowing a

charging generator will then be extended to the fuel-pump solenoid which will bypass the supply of fuel to the inject and bring the set to rest. As the engine comes to rest, voltage from the charging generator will become zero; the fuel-pump solenoid will be released ready for the next start.

To perform a test run, relay MVCR is released by a contact of the remote start relay (RSR) which is energised under push button control.

Description of Plant.

Each set is powered with a Ruston & Hornsby type 4VRH compression ignition engine, developing 38 b.h.p. at 1,000 r.p.m. This type of engine has direct airless injection and the absence of a pre-combustion chamber contributes to quick and reliable starting from cold. A thermostatically controlled immersion heater is fitted to the cooling system to further facilitate reliable starting. Starting is achieved by a C.A.V. axial-type starter, designed to mesh with a gear ring on the fly-wheel; the starter circuit

is disconnected and the starter withdrawn from mesh when the voltage of the battery-charging generator builds up as the set accelerates.

The supply of fuel oil in the service tank is maintained by a float-controlled gear-type pump. An alarm is provided by a second float switch if the fuel level falls below the normal low, at which stage adequate reserve will still exist for the engine to run on full load for twenty-four hours, to ensure that attention can be given before the engine will fail due to lack of fuel. The radiator cooling system is maintained full by an external header tank and again an alarm is given by a float switch if the level falls unduly low.

The engine is direct-coupled to a 20-kW, 25-kVA, 240-V, single-phase, Crompton-Parkinson alternator; the exciter is a belt-driven machine of the magnicon type.¹ The magnicon exciter provides a self-regulating machine, and can be set to have a rising load-voltage characteristic which in combination with its falling speed-voltage curve gives a substantially constant voltage over the whole range, from no-load to full-load.

The engine and generator are mounted on a combined bedplate which is supported by the usual type of spring anti-vibrators.²

The general arrangement of the engine room at an intermediate station is shown in Fig. 2.

Although three-phase mains are provided at all stations, there is no three-phase apparatus installed. Unfortunately, it proved impracticable to accurately balance the load between the three phases and hence it was more economical to provide a single-phase standby set of the required capacity rather than a 3-phase machine of three times the capacity of the most heavily loaded phase.

The control relays and contactors are of the heavy-duty power type and are clearly shown in the photograph in Fig. 3. The operating time of these relays is approxi-

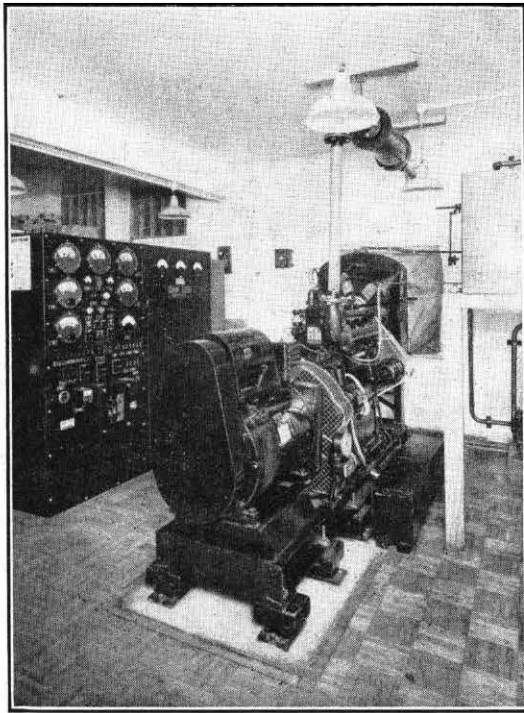

FIG. 2.—GENERAL ARRANGEMENT OF ENGINE ROOM AT AN INTERMEDIATE STATION.

mately 30 mS at normal voltage, and the release time is approximately 20 mS. Time lags, where required, are provided by oil dashpots, but the circuit has been designed

¹ *Electrical Times*, 12th and 19th April, 1951.

² *P.O.E.E.J.*, Volume 43, page 43.

so that any small change in the time characteristics of the dashpots will not interfere with the sequence of operation. These power relays provide a wide margin of safety in the operating conditions that they will tolerate, and are simple to adjust without the need for special tools and gauges.

The control gear is mounted in a free-standing sheet-steel cubicle provided with rear access doors. All wiring is carried out in flameproof cable, and the plant is

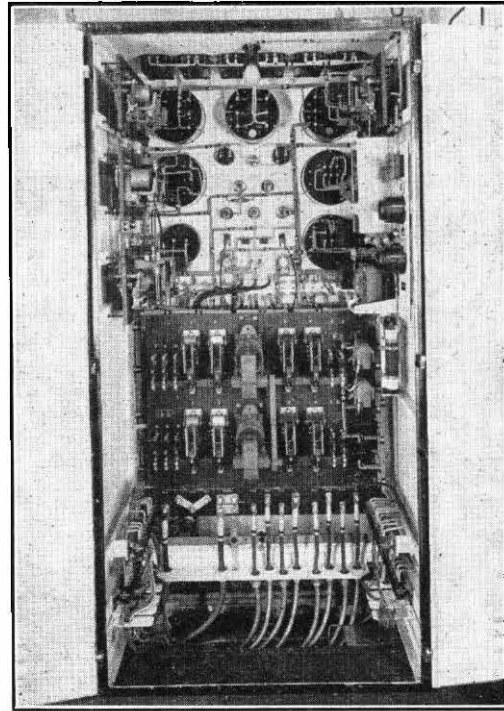

FIG. 3.—INTERIOR OF AUTOMATIC CONTROL CUBICLE.

arranged so that any component can be readily dismantled and removed for replacement or repair should this be necessary. The A.C. and low voltage D.C. terminals required for the connection of the remote signals and other control circuits are on opposite sides of the cubicle. Flush-mounted contact voltmeters and contact frequency meters (these latter for standby supply) are used for monitoring the supplies. The test push-buttons for starting and stopping the set and for simulating a mains failure are mounted on the front of the cubicle. Auxiliary contacts on the mains and standby contactors are used to operate the relays provided by Standard Telephones & Cables to extend the remote "power source" signals.

A matching cubicle is provided for housing the earth leakage circuit breaker and protective fuses for the incoming supply, the load ammeters, and the distribution fuses. This cubicle also houses a changeover switch designed to take all power off the automatic cubicle for maintenance purposes and simultaneously to isolate the start circuit and extend a maintenance-attention signal to the control stations. Provision is also made for re-distribution of the load between phases should this become necessary due to extensions or changes at a future date.

Automatic inlet and outlet louvres are provided for the ventilation of the engine room. These louvres open when the standby contactor closes so that ventilation is only provided whilst the set is on load. The louvres are actuated by a system of bell-crank levers and rods, and power is provided by a single-phase permanent split capacitor motor. A changeover limit switch is provided to stop the motor at the end of the travel of the louvres in each direction, and ultimate limit switches are also provided to prevent damage in the event of failure of the changeover switch.

Operation of Plant on Test and in Service.

The results obtained on test at works and on site have been satisfactory and the plant has functioned exactly as was anticipated.

The speed and voltage regulation figures obtained for engine and generator on station load are:

Full-Load—Steady	960 r.p.m., 240 Volts
No-Load—Instantaneous	1,080 r.p.m., 244 Volts
No-Load—Steady	1,020 r.p.m., 236 Volts
Full-Load—Instantaneous	920 r.p.m., 242 Volts

The regulated voltage is dependent on exciter speed, but even with the exciter driving belts deliberately slacked off, a slip of only 50 r.p.m. on a nominal speed of 3,065 r.p.m. was measured and the alternator voltage was not affected.

Repeated operations have demonstrated that the standby sets are on load at nominal voltage and frequency in seven seconds from the failure of the mains. No facilities exist for paralleling the two supplies but the interruption on restoring the mains is only 30 mS approximately.

Fuel consumption at 0.593 lb. per kWh at full load is normal for this size of plant.

Within five minutes of the plant at Blackcastle Hill being

put into service during the evening of 11th September, 1952, a lightning-storm caused an interruption to the public supply. The set started and took the load correctly. The public supply was soon restored, but failed on two further occasions in quick succession. The fact that automatic restoration to mains is not provided, ensured that the set continued to run throughout these interruptions and it is considered that this feature will fully justify its adoption. Later, during the same evening, the set started again on a further mains failure, and maintained the station services throughout the night till shut down the following morning by a visiting officer. Normally, the shut-down can be performed from either of the remote control stations.

Successful tests have been carried out on the remote control of the sets. By selection of a particular intermediate station, and operation of the "power source changeover" switch, any set can be started and, after a suitable running interval (designed to ensure that the battery is completely re-charged), a further operation of the "power-source changeover" switch restores the mains and shuts down the set. The sets are now operating under remote control with daily test runs.

Induced Voltage Tests Carried Out in Conjunction with the London Electricity Board

ON 9th and 23rd March, 1952, the London Electricity Board carried out cable-spiking tests on an energised 22-kV cable. Cable spiking, which is the driving of a chisel-pointed tool into the cable, is a means of ensuring that a power cable is "dead" before work proceeds on it, other practicable means of identification having been carried out. The primary object of the tests was to determine the operation of a cable-spiking gun on a 22-kV cable when the cable was alive. With a spiking gun the spike is driven into the cable by the force developed by an explosive charge in the form of a cartridge, the gun being triggered off by a lanyard to permit the striker to be far enough away from the fault to avoid the possible danger that might follow the piercing of a live cable. At the invitation of the London Electricity Board the Post Office co-operated in the tests and took the opportunity of measuring the induced voltage in parallel telephone circuits.

Details of the test circuits are shown in Fig. 1. Induced

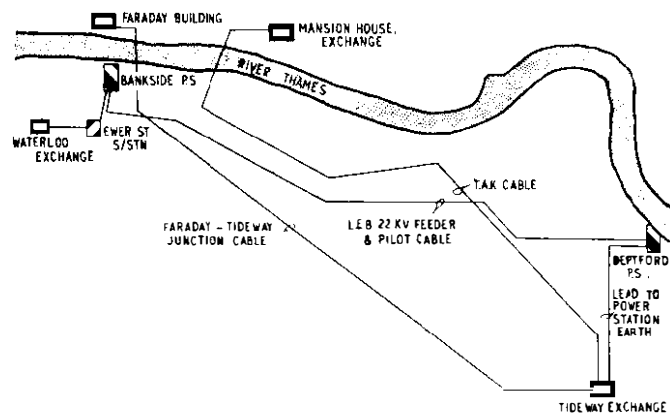

FIG. 1.—DIAGRAMMATIC MAP SHOWING THE TEST CIRCUITS.

voltage measurements were made on circuits in the following cables:—

- (1) A junction cable between Faraday Building and Tideway exchange.
- (2) A telegraph cable (TAK cable) between Mansion House exchange and Tideway exchange.

- (3) A London Electricity Board pilot cable from Deptford West power station to Bankside power station. This circuit was extended over Post Office lines from Deptford to Tideway exchange and from Bankside to Waterloo exchange.

The opportunity was also taken to observe any rise in potential of the main earthing system at Deptford West power station and for this purpose a line connected to the main earthing system of the power station was made available at Tideway exchange. The circuits were terminated on high impedance measuring equipment at Tideway exchange, the measurements being made to the exchange earth system at this exchange, and circuits (1), (2) and (3) were connected to earth at Faraday Building, Mansion House exchange and Waterloo exchange, respectively.

Along the routes of the Post Office cables containing the test circuits and along the 22-kV cable route, there are numerous other power cables and Post Office cables, large metal water pipes, gas pipes, etc. The 22-kV cables are armoured and in some sections the Post Office cables are in cast iron pipes. Owing to the complexity of the arrangement it is not possible to assess the overall screening factor, but it will be appreciated that the screening will be very effective and the screening factor will be low.

In both tests the cable was energised from Deptford West power station and spiked at Bankside. On the occasion of the test carried out on 9th March, 1952, the fault affected only one core of the cable, thus giving rise to a fault to earth on one phase. The following R.M.S. voltages were measured on the Post Office test circuits:—

(1) Faraday-Tideway junction cable	<0.1V
(2) T.A.K. cable	3.1V
(3) L.E.B. pilot cable	290V
(4) Deptford power station earth system	<1V

An oscillogram of the fault current showed the fault duration to be 19 cycles. The voltage drop across a 4.99-ohm earthing resistor in the neutral connection to the earth system at Deptford West power station, from which the 22-kV cable was energised, indicated that the fault current was of the order of 2,300A.

In the second test carried out on 23rd March, 1952, the spike contacted all three phases and short-circuited the system. The fault duration was 17 cycles and the current

7,860A per phase. The voltage drop across the 4-99-ohm neutral earthing resistor was negligible, indicating the speed at which the spike connected the three phases. As the earth fault current was negligible this test was not important from the Post Office point of view.

The results of the first test confirmed that the likelihood of high induced voltages appearing in Post Office lines due to earth faults on power systems is small in the conditions met with in the test, that is in congested urban areas where there are large numbers of power cables, Post Office cables,

water pipes, gas pipes, and other buried metalwork which provide adequate screening. The results also showed under the conditions of the test (i.e. with an earth fault on an entirely underground H.V. power system) no serious rise in potential of the earth electrode system of the power station feeding the cable.

From the point of view of the Electricity Board the tests demonstrated that, by using the cartridge-operated spiking gun, live 22-kV cables may be spiked without risk to operatives and without danger to adjacent cables. H.F.

A Vehicle for Television Outside Broadcast Service

THE new vehicle shown in the accompanying illustrations has been designed to accommodate equipment used by the Post Office in the provision of temporary vision links for B.B.C. television outside broadcasts. Two of the vehicles were in use during the Coronation broadcast; several more will shortly be going into service.

In selecting a chassis for this vehicle great attention was paid to obtaining minimum vibration during running and ensuring the ability to withstand the wear and tear associated with manœuvring the vehicle on and off broadcast sites, some of which may be difficult of access. The main feature of the chassis finally adopted is a suspension system using semi-elliptic springs operating in conjunction with double-acting piston-type hydraulic dampers. The power unit, a 4-cylinder side-valve engine rated at 16 h.p. is mounted on rubber to reduce vibration, and transmits power via a 4-speed gearbox.

the full width of the vehicle is a 2 ft. wide table on which the equipment is set out when the vehicle is on a broadcast site. When not in use the table can be folded back against the partition, leaving maximum clear floor space for stowing equipment in transit. Access to the rear compartment is obtained via a central glazed door at the rear of the vehicle.

To facilitate wiring distribution for the television equipment, a channel fitted with hinged covers in 2-ft. sections extends from a terminal board at the rear of the vehicle to



THE VEHICLE WITH AERIAL ERECTED.

The body of the vehicle consists of a timber framework with outer panels of aluminium alloy and inner panels of plywood, the space between them being packed with a heat-insulating material. The plywood surface forming the interior of the vehicle is covered with P.V.C. fabric. In the rear compartment of the body, partitioned off from the driver's cabin, some 40 sq. ft. of floor space is available with 6 ft. headroom. Against the partition and extending

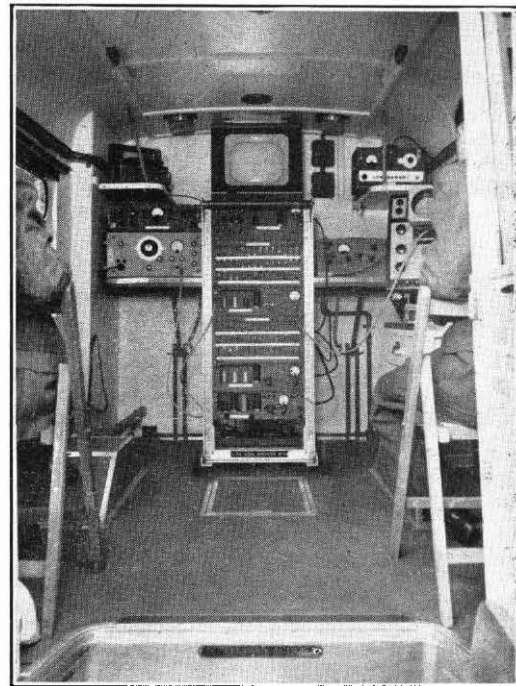

INTERIOR OF VEHICLE SHOWING EQUIPMENT ASSEMBLED FOR OUTSIDE BROADCAST.

the table. The security and neatness of permanent wiring is thus obtained together with flexibility for wiring changes to meet various conditions. Flush-fitting cable entry flaps hinged at their upper edges are fitted on either side of the rear door.

Sockets for carrying the aerial post are located on the outside of the vehicle at the rear. The aerial post shown in the illustration is made up of two sections of standard duralumin pruning rod, a full set of rods being carried so that the height of the aerial may be increased if necessary. The lowest length of rod provides at its upper end a convenient anchorage for power cables. A 3-section aluminium extension ladder is carried in the vehicle secured by straps over the offside wheelarch.

The cab accommodation affords comfortable seating for the driver and four passengers with locker space under the rear bench seat.

G. H. S.

Notes and Comments

Coronation Honours

The Board of Editors offers congratulations to the following members of the Engineering Department honoured by Her Majesty the Queen in the Coronation Honours List:—

Belfast Telephone Area	Murphy, I.	Technician II B..	British Empire Medal
Brentwood Radio Station	Green, P. E.	Technician II A..	British Empire Medal
Engineering Department	Magnusson, L. E.	Senior Executive Engineer	Member of the Order of the British Empire
Engineering Department	West, W.	Staff Engineer	Officer of the Order of the British Empire
Exeter Telephone Area	Langford, A. E.	Technician I	British Empire Medal
Liverpool Telephone Area	Meldrum, F. A.	Area Engineer	Member of the Order of the British Empire

Correspondence on Fumigation of U.A.X. 7

The Managing Editor,

MOTH EGGS IN U.A.X. 7A UNIT

Dear Sir,

The North Eastern Regional note on this subject (p. 185 of your January 1953 issue) states that after fumigation of the apparatus with hydrogen cyanide (prussic acid, hydrocyanic acid, HCN) a thin greyish powder occurred on certain metallic parts which "was understood to be a deposit of hydrogen cyanide, and in this form quite harmless."

We have tried to obtain some of the parts so affected in order to examine this substance, but without success, and hence its exact nature remains a matter for speculation, but it was certainly not hydrocyanic acid itself, which has a boiling point of 26°C, nor is it likely to have been any of the simple compounds of this body, such as metallic cyanides, which are all highly poisonous and would be very dangerous if present in visible quantities. Hydrocyanic acid fumiga-

tion has been practised for many years, but no tendency for it to produce harmful compounds on the treated materials has been observed.

There are several hypothetical explanations which might account for the substance observed, but perhaps the most likely is that it was a corrosion product formed during storage and only noticed in the critical inspection which the unit would naturally receive after such novel treatment; if any more apparatus is similarly disinfected we should like an opportunity to examine any unexpected features which may appear.

Finally, from the description given it seems possible that the "eggs" mentioned may have been larval excrement. True moth eggs are small pearl like objects which require a magnification of 10 to 20 diameters for positive identification.

Yours faithfully,

D. W. GLOVER,
E.-in-C.O., Research Branch.

Institution of Post Office Electrical Engineers

Essay Competition 1952/53—Results

A Prize of £5 5s. 0d. and an Institution Certificate have been awarded to the following competitor in respect of the essay named:—

G. H. Bedford, Technical Officer, E.-in-C.O., Central Training School. "The Problem of Interference to Television Reception from Amateur Transmitting Stations."

Prizes of £3 3s. 0d. each and Institution Certificates have been awarded to the following four competitors:—

S. C. Boas, Technical Officer, E.-in-C.O., I./LB. Branch. "The Problem of Fading on the Long Distance Communication Circuit."

G. Chalk, Technician IIA, Canterbury (H.C. Reg.). "Lift Installations. Aspects of Maintenance and Salient Features of Design Advancement."

G. W. Bates, Technical Officer, E.-in-C.O., Test Section. "Post-war Developments in the Testing of Dials Automatic."

J. L. Bowley, Technical Officer, Melton Mowbray (Mid. Reg.). "Shared Service in Rural Areas."

Institution Certificates of Merit have been awarded to:—

T. S. Stephenson, Technician I, Newcastle (N.E. Reg.). "Post Office Engineering Works—External Construction Methods."

M. E. Lievers, Technical Officer, E.-in-C.O., Central Training School. "The Construction of a Home-built Television Receiver."

R. T. Vaughan, Technical Officer, E.-in-C.O., Test Section. "The Medresco Hearing Aid."

H. Williams, Technical Officer, Holyhead (W. & B.C.). "Picture Telegraphy."

H. M. Beaven, Technical Officer, Bournemouth (S.W. Reg.). "The Lighting of Post Office Buildings."

G. L. Roberts, Technical Officer, E.-in-C.O., Central Training School. "The Principles of the Signalling System A.C. No. 5X."

The Council of the Institution records its appreciation to Messrs. W. S. Procter, F. A. Hough and H. Leigh, who kindly undertook to adjudicate upon the essays entered for the competition.

H. E. WILCOCKSON, *Secretary.*

N.B.—Particulars of the next competition, entry for which closes on the 31st December, 1953, will be published later.

Additions to the Library

2067 *Thermionic Vacuum Tubes.* W. H. Aldous and E. Appleton (Brit. 1952).

An account of the internal action of modern thermionic tubes, and of their behaviour in various typical applications in physics and electrical communication.

2068 *An Introduction to Servo-Mechanisms.* A. Porter (Brit. 1953).

Designed for the physicist, engineer, etc., who is interested in servo-mechanisms rather than for the student who wishes to specialise on the subject.

2069 *Radio, Vol. I.* J. D. Tucker and D. Wilkinson (Brit. 1952).

The first of three volumes on radio for students preparing for the radio examinations of the C. and G. of L. Institute.

2070 *Mechanical Draughtsmanship.* S. M. Hood (Brit. 1952).

A "teach yourself" book giving the basic principles of mechanical draughtsmanship.

2071 *The Skeleton Key of Mathematics.* D. E. Littlewood (Brit. 1949).

A simple account of complex algebraic theories.

- 2072 *35-mm. Photo Technique*. H. S. Newcombe (Brit. 1952).
Correlates the factors concerned in successful photography with small cameras.
- 2073 *Electrical Units (with special reference to the M.K.S. System)*. E. Bradshaw (Brit. 1952).
Primarily designed to explain the basis and use of the metre, kilogram, second, rationalised system of electrical units. Other systems in common use are described in relation to this system.
- 2074 *Sketching for Craftsmen*. E. Hoyle (Brit. 1950).
Designed to impart the ability to make sketches even to those who may never have had instruction in drawing.
- 2075 *Radio Interference Suppression*. G. L. Stephens (Brit. 1952).
An exposition of the principles underlying suppression technique related to radio and television, expanded by illustrations in the form of practical applications to typical interfering appliances.
- 2076 *Practical Watch Repairing*. D. de Carle (Brit. 1946).
Describes the theories of repairing and adjusting the modern watch in precise and meticulous detail.
- 2077 *Stereo-Photography in Practice*. E. F. Linssen (Brit. 1952).
A comprehensive work dealing mainly with the practical aspects of the subject while giving an adequate and concise treatment of theoretical matters.
- 2078 *Engineering Drawing*.—H. T. Davey and R. J. Williams (Brit. 1952).
Contains in detail the fundamental principles of engineering drawing supplemented by a comprehensive set of exercises, primarily designed for prospective students for National Certificate or University Courses.
- 2079 *The Conduction of Electricity Through Gases*. K. G. Emeleus. (Brit. 1951).
An outline of the main phenomena which can be studied quantitatively in connection with the passage of electricity through gases at low pressures, in particular those associated with the glow-discharge.
- 2080 *Photoelectric Tubes*. A. Sommer (Brit. 1952).
Devoted entirely to cells of the emission type, as distinct from cells of the barrier-layer and photo-conducting types.
- 2081 *Enlarging*. G. J. Jacobson (Brit. 1952).
Aims at giving exhaustive information on up-to-date practice based on scientific accuracy.
- 2082 *Atoms and Atomic Energy*. R. W. Hallows (Brit. 1950).
A simple explanation of the subject.
- 2083 *The Automatic Watch*. R. W. Pipe (Brit. 1952).
On the care and repair of self-winding watches.
- 2084 *Mechanics and Applied Mathematics, Pt. I, Mechanics*. W. D. Hill (Brit. 1943).
An endeavour to link up the books, for technical students, in which the machine predominates with those on "pure mechanics."
- 2085 *Mechanics and Applied Mathematics, Pt. II, Applied Mathematics* (Brit. 1943).
A mathematical extension of Pt. I.
- 2086 *Heat*. M. Nelkon (Brit. 1949).
A textbook for Higher Certificate and Intermediate students.
- 2087 *Wave Motion and Sound*. R. W. B. Stephens and A. E. Bates (Brit. 1950).
Designed to cover the needs of the degree student, and assumes only a modest knowledge of mechanics and acquaintance with calculus.
- 2088 *High Speed Photography*. G. A. Jones (Brit. 1952).
An attempt to weld together the broad fundamental theory, practical experience and technical applications of the subject.
- 2089 *Painting and Decorating: Craft Practice*. J. Lawrence (Brit. 1948).
Details those manipulations and technical considerations which are most significant in building up satisfactory paint systems.
- Antenna Theory and Design*. H. P. Williams. (Brit. 1950).
- 2090 *Vol. I, Foundations of Antenna Theory*
- 2091 *Vol. II, The Electrical Design of Antennae*. A comprehensive treatise on the subject.
- 2092 *Television Engineers' Servicing Manual*. Ed. E. Molloy and W. F. Poole (Brit. 1952).
A comprehensive and practical manual dealing with the installation, repair and maintenance of television receivers. Contains servicing data on all the leading makes.
- 2093 *Radio Engineers' Servicing Manual*. Ed. E. Molloy and W. F. Poole (Brit. 1952).
An authoritative source of technical information on post-war broadcast, automobile and communications-type radio receivers. Contains precise servicing instructions for more than 500 post-war models.
- 2094 *Modern Electric Lamps*. D. A. Clarke (Brit. 1952).
Designed to meet the needs of University and Technical College students, and of the practising engineer.
- 2095 *Applied Heat for Engineers*. J. B. O. Sneed (Brit. 1953).
Suitable for Pt. 1 of London University and other degree exams., and of interest generally to those interested in heat engines.
- 2096 *D.C. Machines for Control Purposes*. A. Tustin (Brit. 1952).
An account of the various kinds of D.C. machines and machine combinations that are suitable for use as "rotary power amplifiers" in automatic control systems.
- 2097 *Road Engineering*. E. L. Jeeming (Brit. 1952).
Expounds the engineering principles of road making.
- 2098 *Methods of Statistics*. L. H. C. Tippett (Brit. 1952).
A general but systematic introduction to the methods of statistics.
- 2099 *Electronics: Experimental Techniques*. W. C. Elmore and M. Sands (Amer. 1949).
A laboratory manual on the practices found most useful in the Los Alamos Scientific Laboratory.
- 2100 *Waveguide Handbook*. N. Marcuvitz (Amer. 1951).
A Massachusetts Institute of Technology book, which endeavours to present the salient features in the reformulation of microwave field problems as microwave network problems.
- 2101 *Writing the Technical Report*. J. R. Nelson (Amer. 1952).
A comprehensive manual on the fundamental approach to and methods of writing technical reports.
- 2102 *Proceedings of the Convention on the British Contribution to Television*. I. E. E. (Brit. 1952).
- 2103 *Vacuum Tube Amplifiers*. Ed. G. E. Valley and H. Wallman (Amer. 1948).
A Massachusetts Institute of Technology Radiation Laboratory book which discusses the principles of circuit design for circuits that are essentially linear (amplifiers).
- 2104 *Waveforms*. Ed. B. Chance and others (Amer. 1949).
An M.I.T. Radiation Laboratory book attempting a comprehensive survey of basic circuit techniques used in the generation and manipulation of voltage and currents by essentially non-linear circuit elements.
- 2105 *Code for Protection against Lightning*. U.S. National Bureau of Standards (Amer. 1952).
Includes protection of buildings, oil tanks and other structures; trees, livestock, and persons; overhead electric lines, and apparatus connected with them.
- 2106 *Radio Upkeep and Repairs*. A. T. Witts (Brit. 1952).
A practical handbook on servicing principles and receiver maintenance.
- 2107 *Modern Applied Photography*. G. A. Jones (Brit. 1953).
Surveys the scope of applied photography in most major branches of industry, emphasising its value in research and investigation as well as in simple recording.

W. D. FLORENCE, Librarian.

Correction.

In the list of Associate Section Papers Awards—Session 1951/52 published in the April 1953 issue, L. S. Hurst should read J. B. Bedford. The award to Mr. Hurst, Technical Officer, Tunbridge Wells Centre (H.C.R.), was for his paper on "Lifts."

Regional Notes

London Telecommunications Region

"BOARD OF EDUCATION" MAIN DISTRIBUTION FRAME

Over 40 years ago a distribution frame was installed in the basement of the New Public Offices, Whitehall, to provide flexibility between all Government Offices in Whitehall. The building at that time was six years old and the frame was situated in the part allotted to the then Board of Education, hence the name. Despite successive changes of occupancy, the name has remained.

Having seen service through two world wars and having carried circuits for practically all the great names during the

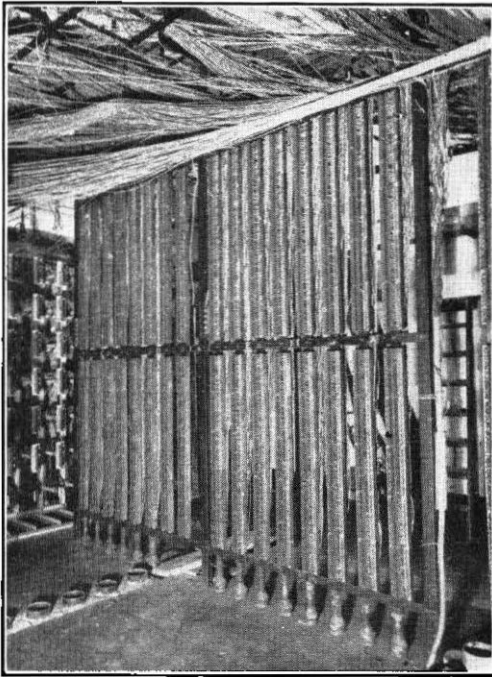

SECTION OF "BOARD OF EDUCATION" M.D.F. PRIOR TO RECOVERY.

last 40 years, present-day requirements were more than it could cope with, and it was decided, with some regret, that complete renewal was the only solution. The work involved the diversion and retermination of 34 existing cables containing 15,000 pairs and the provision of five new cables containing 3,700 pairs. The work was planned to commence in 1951 and finish in 1955, but the large number of circuits for the Coronation which were routed via the frame made completion by 1953 necessary.

The illustration shows the last remaining section of the old frame.

L. G. W.

FARADAY BUILDING TRUNK AND TOLL TEST ROOM

A stage in the opening of the combined Trunk and Toll test room in the South East Block of Faraday Building was reached on 2nd May, when 2,538 controlled trunk circuits were transferred from the superseded Trunk test room in the North Block. Prior to the changeover all these outgoing and bothway circuits had been brought through the test break-jacks in the new test room either in series or in parallel with the old test break-jacks, whichever gave the more simple routing through distribution frames. In this operation some 23,000 jumpers were run in. As work on each circuit was completed it was tested from new and old test rooms before being restored to traffic.

The changeover was made early in the morning. Operators made a complete test of all manual circuits in the 109 routes involved, and the auto-maintenance staff tested circuits outgoing from selector levels. Faulty circuits were out of service, therefore, before the day's traffic commenced and all were restored by the afternoon, except for seven circuits on which there was no co-operation at stations and for two circuits

involved in cable faults. Less than a third of the faults reported were actually the result of the changeover.

The first trunk circuits were opened in this test room in September last year, when 2,096 full-time and part-time private circuits were transferred, together with the picture services and inland music circuits. With the transfer of the incoming trunk circuits and junctions from the North Block test room and the turn-round of the Toll suites still to be completed, it is now planned to complete the work before the end of the year.

The combined Trunk and Toll test room will then be the circuit control for about 24,000 circuits and the non-controlling terminal test room for a further 4,300 circuits. It will have on one floor 74 test-racks, together with transmission test bays for performing D.C. and multi-frequency A.C. tests on these circuits, and has been designed to be ready for the opening of the Faraday N.D. Trunk Mechanisation Unit early next year.

R. F. H.

North Eastern Region

DEMOLITION OF A JOINT BOX AFTER FLOOD DAMAGE, USING EXPLOSIVES

Sandsend is a quiet seaside holiday resort near Whitby. Underneath the narrow main road, which is also the promenade, are the main Middlesbrough-Whitby junction cables. On the evening of Sunday, 1st March, 1953, the sea had broken down the promenade in many places but was held at one place by a Post Office reinforced joint box (JRC 9). On the Monday morning, however, the joint box was found partly inverted suspended on the cables. Only one cable was damaged—a slight tear in the lead sheath.

Something had to be done quickly as the next tide was expected to cause more damage, and to make matters worse the Scarborough-Whitby cable, the only other outlet from



THE JOINT BOX SUSPENDED ON CABLES.

Whitby, was faulty elsewhere. The area would thus be isolated unless the cables could be removed from the joint box and made safe.

The first job was to relieve the cables of the weight of the box. Two light poles were used as levers and, with the aid of a pole jack, the box was lifted and held steady by a packing of boulders, etc. It was impossible to get a compressor to the site in time to be effective and hammer and bar had little effect on the reinforced concrete. Fortunately, however, the gang employed happened to hold a supply of blasting material and it was decided to use it for demolishing the box.

The cables were first protected with sandbags and two half-charge plaster shots used to remove some of the thicker concrete. Then four half-charges were placed at equidistant points in line with the duct run and exploded with the result that the whole length of the corner of the box was removed down to the duct mouth on either side. All that remained to complete the demolition was to bend the reinforcing rods back, break the ducts and remove the cables. The tear in the cable sheath was then repaired and the cables placed between sandbags at the bottom of the crater. This arrangement withstood the next high tide and with the abatement of the seas it was possible to start building a new box.

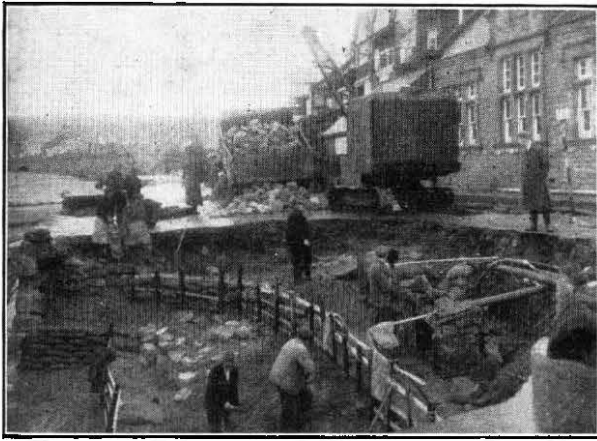

REPAIRS IN PROGRESS AFTER DEMOLITION OF JOINT BOX.

Apart from having to cater for surplus cable due to stretching and pulling along the length no actual damage was caused to the cables. A. C.

Scotland

CONVERSION OF GREENOCK, GOUROCK AND PORT GLASGOW TO AUTOMATIC WORKING

At 2.11 p.m. on 2nd May, 1953, Her Majesty's Postmaster-General, Earl De La Warr, gave the signal to proceed with the simultaneous transfer of the telephone systems of the Burghs of Greenock, Gourrock and Port Glasgow to automatic working. The transfer was effected smoothly in just under four minutes.

The three towns extend for some nine miles along the south shore of the upper reaches of the Clyde Estuary, the largest—Greenock—being in the centre. The system consists of a non-director main exchange with group centre auto-manual board of 25 positions at Greenock, and satellite exchanges at Gourrock and Port Glasgow, the equipped multiple capacities being 4,500, 1,600 and 600 respectively. The satellite exchanges are discriminator-type with multi-metering facilities.

Prior to the conversion, the U.A.X.s within the multi-feed area were parented on a relief exchange, originally set up as a war-time emergency exchange, but latterly carrying U.A.X.

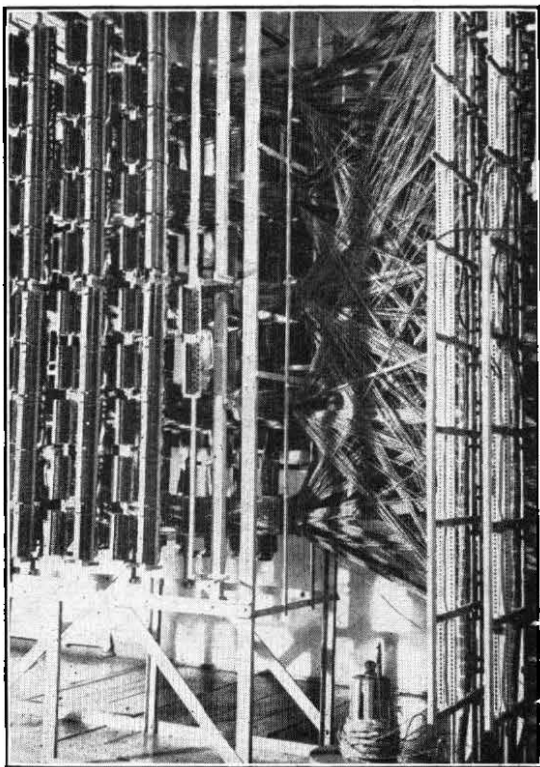

FRAMEWORK CONSTRUCTED FOR TRANSFER AT GREENOCK EXCHANGE.

traffic only. Advantage was taken of this arrangement to simplify the main transfer by bringing the new auto-manual switchboard into service six weeks in advance, all junctions working to Greenock relief exchange being transferred to it at that time, together with additional temporary junctions to the manual exchanges, primarily for the routing of coin-box traffic during the interim period. In this way, the main transfer was relieved by about 90 junctions of which 65 were complicated U.A.X. circuits, and the operating staff had the opportunity of gaining experience of the sleeve control switchboard under light load conditions. The conversion of coin-box lines was also simplified as it was possible to convert them one by one and give them access over level "0" to the auto-manual board.

The method of transfer adopted was "looping-in" to the new exchange and thence via changeover strips to the old exchange. This was possible with all but a small number of lines which had to be routed via the old exchange and over back-end pairs to the new exchange.

The Strips, Changeover, 200/200 were made up in pairs wired to connection strips on a specially designed mild-steel framework thus making up 200-line units which can be used again on subsequent transfers. These units were mounted on angle-iron racks accommodating up to six units each. Two racks were placed back to back at each end of the M.D.F., and spaced sufficiently far from it to accommodate a vertical jumper field through large circular rings at each horizontal level. Siting the changeover strips at each end of the M.D.F. reduced the jumpering congestion to a minimum.

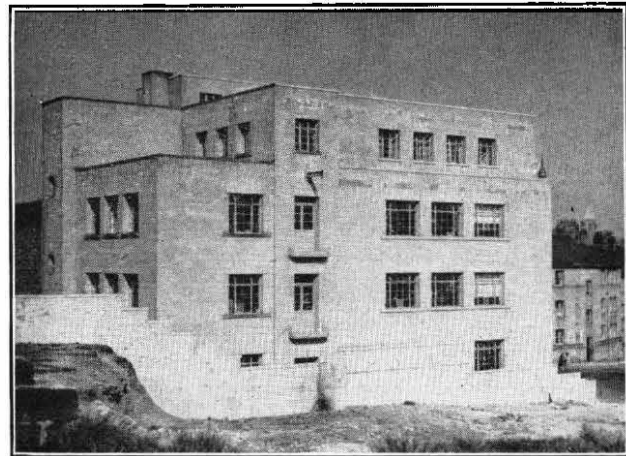

GREENOCK AUTO EXCHANGE BUILDING.

An underground development scheme was carried out in conjunction with the transfer jointing scheme, opportunity being taken to relieve congestion in existing manholes and duct lines by routing the main distribution cables (1,000 pair) for a considerable distance through a new duct system along less congested streets. In consequence the scheme was very complex and difficult to carry out, but the ultimate result will be a very substantial improvement in the underground cable network.

A similar transfer method was adopted at Gourrock, but at Port Glasgow it was necessary to route a much larger proportion of circuits via the old exchange, some being teed on the old M.D.F. and others using back-end pairs to the new exchange.

Owing to restrictions on capital expenditure and other difficulties the completion of the building at Greenock was considerably behind schedule, and the satellite exchange equipment was lying idle—apart from periodic routines—for over two years. The building, comprising four floors and basement, is constructed of white sandstone in conformity with other new buildings in the vicinity. Its appearance is austere but substantial. In addition to the telephone exchange it houses a repeater station.

The old C.B. 22V exchange at Greenock was originally installed in 1908 for the National Telephone Co. It has been added to and modified considerably over the years, but the original 13 positions were still in service up to the time of the transfer.

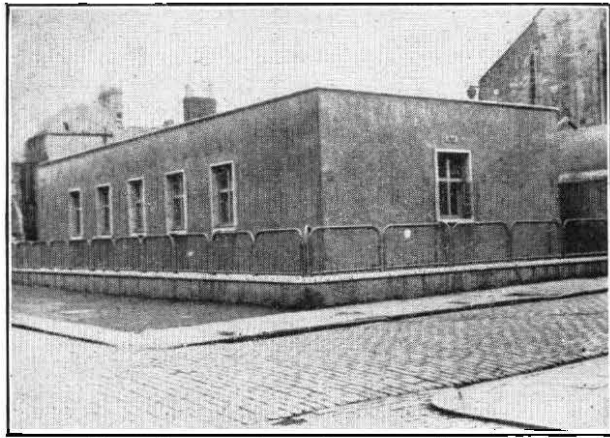

PORT GLASGOW AUTO EXCHANGE BUILDING.

As to Port Glasgow magneto exchange (*circa* 1914) perhaps the less said the better! The building housing it is scheduled for demolition at an early date.

Gourock old exchange was C.B.S. No. 2 extended by every possible expedient to cover the successive delays in the programme for its replacement.

So a conversion originally scheduled for completion in 1939 was finally accomplished in 1953. D. E. N. J.

Home Counties Region

DISPLACEMENT OF UNDERGROUND CONDUITS BY LANDSLIP

A recent landslip on the "A" 22 road occurred near East Grinstead and caused a series of steps of earth, some of which were over the Department's underground plant, consisting of one 3-W.M.D. and four asbestos ducts. Conduits were broken and out of alignment and cables were shifted from the cable bearers and drawn tight across manholes.

The conduits contained cables carrying nearly 700 trunk and junction circuits and great care was necessary to avoid a breakdown.

It was decided to expose the whole of the track, and to enable this to be done it was first necessary to ensure there



U.G. CONDUIT DISPLACED BY LANDSLIP.

would be no further slip of the already very fluid subsoil. Large quantities of shuttering, struts, and walings were therefore moved to the site and placed in position as digging proceeded. Some difficulty was experienced in finding a stable subsoil and for this reason timber piles had to be driven.

It was found necessary to excavate, over a length of 30 yards, a trench 5 ft. wide and 6 ft. deep. After the uncovering of the track careful slinging was arranged preparatory to restoring the conduits to their original positions. The conduits were then raised and slung in such a manner as to enable the road authorities to provide a concrete wall under the road haunch and thus seal off any further slip. After the wall was built, concrete grout was forced by means of a high-power compressor through holes bored through the concrete into the voids underneath.

The excavation was then filled, the conduits made good and the Post Office cables restored to their correct positions in the manholes. The cables do not appear to have suffered in any way. A. F. S.

Wales and Border Counties

TIMBER U.A.X. BUILDING

What is believed to be the first of the new type of timber U.A.X. buildings was built recently at Harewood End, Herefordshire. The work was caused by the unforeseen resignation of the caretaker operator which necessitated the transfer to a U.A.X. 12 from a C.B.S. No. 2 exchange. Owing to the inability of the Department to get a contractor to undertake the foundation, erection and other work on site the building was erected by departmental labour, including the subsidiary work of paths, fences, soakaways, etc.

The front view of the building is shown in the accompanying illustration. The interior of the building is lined with plaster board and when finished and painted presents a very pleasing appearance, much superior in the minds of the staff to the standard brick-type building. A further advantage is the equalisation of temperatures due to the cavity walls, which is very noticeable. A false ceiling is included which enables heating, in winter time, to be achieved far more readily.

The external cladding is a Malayan hardwood and is lined internally with a metal-foil-backed asbestos board. In spite of certain teething troubles, it was possible to make a sound job of the construction from the information supplied, and no undue difficulties were experienced. It would be an advantage, however, if more detailed instructions and drawings were issued, and this point, with other minor suggestions for improvements, has been referred to Headquarters.

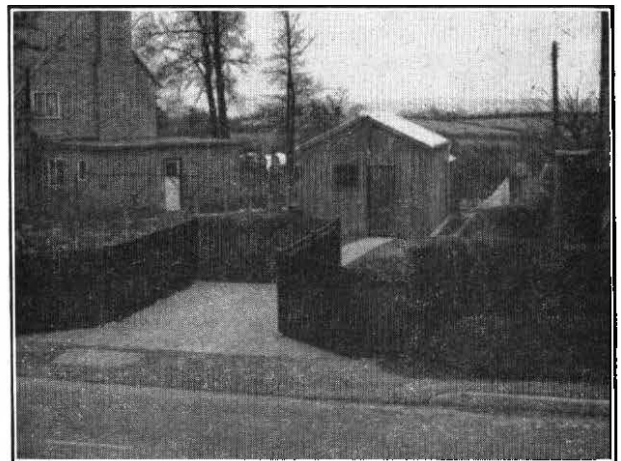

TIMBER U.A.X. BUILDING, HAREWOOD END.

The normal method of erection of this type of building is by contract, but an important feature is that the Department can erect them with its own labour, in places remote from the town, where it has frequently proved impossible to get a contractor to undertake small building work. This has proved to be particularly so since the licence restrictions on the building of private dwellings were eased and building contractors have been disinclined to travel long distances for comparatively small jobs. G. J. A. A. T. D.

Associate Section Notes

Birmingham Centre

The completion of another successful session can be reported by this Centre and, apart from the normal meetings and visits, it was notable for the fact that over 100 new members have been enrolled during the past 12 months.

One of our own members, Mr. J. S. Kendall, read a paper entitled "Amplifiers" at the March meeting, and this was illustrated by lantern slides prepared by the author. The final talk of the session, in April, was given by Mr. Barrie Edgar, the Television Outside Broadcast Producer for the Midland Region of the B.B.C. A most amusing and interesting speaker, Mr. Edgar traced the progress of television in this country, gave a short review of his own career in Outside Broadcasting, and concluded by explaining how such features are planned and executed. His many anecdotes of both amusing and embarrassing experiences provided all present with a most entertaining evening.

Unfortunately the afternoon visit to the Austin Motor Works, which had been arranged for March, had to be cancelled, but it is hoped to arrange this again later in the year when normal production has been resumed. A Saturday morning visit in April to the B.B.C. Engineering Training School at Wood Norton, near Evesham, was well supported and thoroughly enjoyed by all who took part. To accommodate all those wishing to visit the TV Transmitter at Sutton Coldfield, further visits have been arranged, and eventually some 80 members will have taken advantage of this visit made with the co-operation of the B.B.C. Engineer-in-Charge.

The Annual General Meeting was held at the end of April, the following being elected for the 1953/54 session:—

Chairman, E. W. Newnham; *Secretary*, K. G. S. Adams; *Assistant Secretary and Librarian*, W. G. Johnson; *Treasurer*, A. C. Rotherham; *Committee*, S. Hayward, K. W. Gibbs, B. W. Headley, A. E. Carpenter, F. Edmonds, F. G. Windsor, and J. H. Cockbill; *Auditors*, J. R. Ford and H. E. W. Dinnes.

The officers and committee are working to provide yet another interesting series of talks and visits, and it is hoped to have the programme for the next session drawn up by the time these notes appear in print. Details will be included in the next notes.

A further attempt to increase the membership by publicising the activities and facilities offered by this Centre is being carried out by an article in the first issue of the Area magazine and by a letter to all Staff in the Area. K. G. S. A.

Brighton Centre

The 1952/53 session was concluded with a film show on the 18th February, 1953, which was well attended, there being about 60 members present, including about a dozen Senior Section members. Films shown included "Faster Than Sound," showing how the problems of the sound barrier were tackled by scientists, and a preview of part of the film entitled "Atomic Physics," which it is proposed to show in full during the 1953/54 session.

The A.G.M. was held on 11th March, and was attended by 36 members. Mr. F. T. Carwin was elected as *Chairman*; Mr. K. W. Chandler, *Vice-Chairman*; Mr. K. E. Guest, *Secretary*; and Mr. R. F. J. Beddis, *Treasurer*.

Regarding activities for the coming session, the officers and committee are preparing a programme, based on suggestions made by members present at the A.G.M. In connection with this we are looking forward to a talk to be given by a Senior Section member, Mr. A. C. Young, who has just returned from a liaison visit to the United States of America.

In conclusion, we are pleased to be able to report an increase in membership of over 30 since the start of the 1953/54 session. F. E. G.

Carlisle Centre

The Annual General Meeting of the above took place on Tuesday, 14th April, 1953.

The following officers were elected:—*President*, Mr. L. A. Triffitt, B.Sc., A.M.I.E.E.; *Chairman*, Mr. H. R. N. Inniff;

Vice-Chairman, Mr. J. M. Gibson; *Secretary*, Mr. W. A. Harper; *Deputy Secretary and Librarian*, Mr. H. B. Coulthard; *Committee*, Messrs. C. B. McCarthy, J. Hammond, J. T. Harrison, G. T. Priestley, R. Cleaver, A. Wilson, S. Shane; *Hon. Auditors*, Messrs. P. Scott, A. Wilson.

Visits were made by members to the new rotary printing press of *The Carlisle Cumberland News*, on 14th May and 21st May. Arrangements have been made for a conducted tour of the workings of the Mersey Tunnel on Saturday, 3rd October, 1953

The programme for 1953/54 is as follows:—

Tuesday, 8th September, 7.30 p.m.—"The Work of the Telephone Branch Laboratory," by Mr. M. Mitchell, B.Sc., A.M.I.E.E. (Engineer-in-Chief's Office, London).

Tuesday, 13th October, 7.30 p.m.—"Why a Waiting List?," by Mr. G. Thompson (Sales Supt., Lancaster).

Tuesday, 10th November, 7.30 p.m.—"Radio Activity," by Mr. C. S. Jex, B.Sc. (Senior Physics Master, Carlisle Grammar School).

Tuesday, 12th January, 1954.—"Trunk Mechanisation," by Mr. R. D. Thirsk, D.F.C., T.D., A.M.I.E.E. (Executive Engineer, Lancaster).

Tuesday, 9th February.—"Mountaineering," by Mr. R. Cleaver (Technical Officer, Carlisle).

Tuesday, 9th March.—"Radio and Television Interference," by Mr. G. C. Sumner (Assistant Engineer, Lancaster).

Tuesday, 13th April.—"Annual General Meeting."

W. A. H.

Chiltern Centre

Meetings this session have been rather below average for attendance, but interest in the talks and lectures arranged has been well maintained.

The last (April) meeting, when Mr. R. C. Such, Area Engineer, talked to us on "Some of our Problems," was well attended and many questions were asked and answered.

Following the A.G.M. discussion on increasing membership of the Centre, a special effort was made to interest construction staff in the Centre. As a result of this "drive" five new members were enrolled, and we now have most sections of the staff represented.

The debate, "Is Television Worth While?," though informal, was lively and successful, and the discussion brought forth many points of view for and against.

A party of 14 members will shortly be visiting London Transport Signal School at Earls Court, and a visit to a local printing works is being arranged in November.

Members are now being approached for their opinions on the possibility of forming a local library of technical books with the object of adding interest to our activities, and providing additional facilities to members.

Mr. A. H. C. Knox, Regional Engineer, pays us a return visit in September, his subject this time being "Costs and Statistics."

H. J. T.

Darlington Centre

The final meetings of the session were held as follows:—

24th February, 1953.—Mr. H. Naylor's talk, "Some Notes on Amplifier Design," attracted a good attendance. The speaker—a good friend of the Centre—has given several talks on various subjects and this one, as usual, was most informative and thoroughly enjoyed.

12th March, 1953.—"Two-Way Quiz, Darlington v. Middlesbrough." It was soon obvious that both teams were on their toes and after strenuous efforts to gain a useful lead of points in the first half, the final score was Darlington 73.5 points, Middlesbrough 63 points.

The Area Engineer (Mr. F. W. Allan) kindly acted as referee. The Centre appreciated the presence of the Telephone Manager, Colonel J. R. Sutcliffe.

24th March, 1953.—"Shared Service," by Messrs. A. Chapman and E. R. Trotter, was followed with interest, and in the discussion some knotty points were clarified and all questions answered to the evident satisfaction of those who put them.

Hearty congratulations are extended to the Middlesbrough Centre, and to one of their members, Mr. W. J. Costello, who has received a National Award.

It is indeed gratifying to record that the two Centres, Middlesbrough and Darlington, functioning in the one Telephone Manager's Area have each received this signal honour.

C. H.

Middlesbrough Centre

The final meetings of the Centre for 1952/53 were held as follows:—

February, 1953.—A most interesting paper, entitled "Shared Service," was read by two Senior Section members, Messrs. A. Chapman and E. R. Trotter. The attendance did not reach the usual numbers due to the adverse weather conditions resulting in the staff working on storm repairs. The authors have kindly agreed to give the paper again next session for the benefit of those members not able to attend the last meeting.

March, 1953.—The "quiz" with our near rivals, Darlington, was held on the 12th. We congratulate them on a good victory achieved by greater "staying power." The "quiz" was ably controlled by Mr. Allan, Area Engineer, to whom we offer our thanks.

The committee encourage and welcome all papers given by Associate Members and hope to maintain the high standard attained in previous years.

Following one of our members, R. V. Heppinstall, winning the Chief Regional Engineer's prize last year, we note with great pleasure that our Vice-Chairman, Mr. W. J. Costello, has been awarded a National Institute Certificate and £3 3s. for his paper, "Repeater Station Power Plants." We extend to him our warmest congratulations.

The session closed with the Annual Meeting on 14th May.

J. B.

Dundee Centre

The end of another successful session has been reached, and the Dundee Centre can look back on a session in which they have heard read some very interesting papers. In November, Mr. Knox, the local Area Engineer, read a paper on "Provision of Service—The Organisation Behind It." December brought us another interesting paper on the "Teleprinter Auto Switching System," by Mr. J. W. Rance, of P.O. H.Q., Scotland. In January, the outline of "Electronic Switching Methods" was read by Mr. N. T. C. McAffer, our Liaison Officer. A visit to a local engineering works was arranged for February, and in March a film show preceded our A.G.M., at which the following office bearers and committee were elected:—*Chairman*, L. E. Pinner; *Vice-Chairman*, J. A. Lamb; *Treasurer*, K. K. Summers; *Secretary*, R. L. Topping; *Committee*, D. F. Strachan, T. B. Carling, E. A. W. Page, A. C. Gow, J. Duncan and D. L. Millar, Jun.

In the 1953/54 session we look forward to another interesting programme and it is to be hoped that the interest on the part of the members will give every encouragement to the planning of a successful programme.

R. L. T.

Edinburgh Centre

After quite a successful season, the Edinburgh Centre concluded this session's programme with a visit to the Kirk o' Shotts Transmitter. Such outdoor visits here proved very popular and many more are being planned for the coming session.

On 13th April, after an interesting talk on "Cable-balancing," by our Chairman, Mr. J. Phillips, the A.G.M. was held, and the following office bearers were elected:—

Chairman, Mr. J. Phillips; *Secretary/Treasurer*, Mr. J. R. Haggart; *Committee*, Mr. J. Killard, Mr. G. Anderson, Mr. T. Walters, Mr. C. Fraser.

Many interesting and varied activities are being planned for 1953/54 and new members are welcomed at any of the meetings and visits that have been arranged.

J. R. H.

Glasgow & Scotland West Centre

The Glasgow and Scotland West Centre have fulfilled their programme of events for the session with a series of most enjoyable visits and lectures.

Since the last report, Mr. Geo. Campbell, from the C.R.E.'s Office, Edinburgh, has read a paper which dealt comprehensively with the "Trunk Service." This was followed by a visit to the "All-Electric" Signal Box at St. Enoch Station. Then came another very welcome visitor from the C.R.E.'s Office, Edinburgh, in the person of Mr. T. Moxan, who gave a most interesting discourse on "Broad Band Radio Links." He was reluctantly released to catch the last train back to Edinburgh!

The Vice-Chairman and Secretary visited Hamilton, where a new Associate Section is being formed. The attendance and interest shown augurs well for Hamilton, and we wish them every success in their new venture.

J. F.

Isle of Wight

A very interesting session has been concluded with the Annual General Meeting held in April, 1953; the following members were elected as officers:—

Chairman, C. J. Stubbington; *Vice-Chairman*, H. W. Jones; *Secretary*, A. J. Elliott; *Treasurer*, D. Russell; *Librarian*, R. Baker; *Committee*, W. Cook, R. B. Richards, B. Wyse.

During the session, instructive and interesting talks have been given, including "Finance in the Area," by R. Goford, Area Engineer, "Trunk Mechanisation, Dialling and Signalling aspects," by R. F. Howard, of the E.-in-C.'s Office. An interesting film of "Local Interest" was given by F. Mellanby.

Visits were made to the Air Display at Farnborough, to Broadcasting House, and to the National Physical Laboratory at Teddington.

The membership figure is now 69 and it is hoped that the 1953/4 session programme which is now being arranged will encourage more members to attend the meetings.

A. J. E.

Hastings Centre

On 26th November, 1952, the inaugural meeting of the Hastings Centre, Associate Section, was held, with Mr. Barratt, Area Engineer, in the chair and Mr. Knox, Regional Liaison Officer, as guest speaker.

The following officers were elected:—

Chairman, Mr. J. Haynes; *Secretary*, Mr. I. J. S. Walters; *Committee*, Messrs. L. Ayton, H. Matthews, W. F. May, K. Noakes, H. Northwood, W. Rolfe.

Six meetings were held, at which the following subjects were covered, five of them by local associate members:—

"Appraisements and Promotion," Mr. A. H. C. Knox
"Inland and Overseas Radio Links," Mr. D. Balchin
"Lifts," Mr. L. Hurst. "Stability of Power Supplies," Mr. W. E. Thompson. "Holiday Travel," Mr. T. W. Whitmore. "Sound and Hearing," Mr. H. Northwood
"Australian Telephone System," Mr. H. Haynes. "British Telegraph Switching," Mr. K. Noakes. "Use of Break Jack on Exchange Transfers," Mr. T. W. Whitmore.

A very successful visit to the local gas undertaking completed the programme.

At the Annual General Meeting held in March, 1953, the Area Engineer presented the Centre with its "Certificate of Registration," the chairman accepting on behalf of the Centre. The elections resulted in the chairman and secretary being re-elected, the new committee being:—Messrs. J. Bloor, R. P. Holdstock, J. Loker, W. F. May, H. Northwood, W. W. Yeats.

We would like to thank all the Senior Section members for the assistance and interest they have taken in this new Centre.

L. J. S. W.

Leicester Centre

The first Annual General Meeting was held on the 20th April, 1953, with Mr. R. Medland in the chair.

The Secretary and Treasurer gave very satisfactory report of the Branch activities and finances. In his report, the Secretary said that since the Centre was reformed on th

13th October, 1952, two excellent lectures had been given by members. In addition, visits to the Leicester works of Dunlop, Ltd., the British Electricity Authority Leicester Generating Station and the City of Leicester Water Department Pumping Station at Cropston had been made and were well attended. At the pumping station the main item of interest was a steam "Beam" engine, some 80 years old, now due to be replaced by more modern electrical equipment.

The following officers were elected: *President*, E. S. Loosemore, B.Sc., A.M.I.E.E., Area Engineer (Acting Telephone Manager); *Chairman*, C. J. Wykes; *Vice-Chairman*, J. R. Medland; *Secretary*, T. E. Lord; *Treasurer*, J. R. Cambridge; *Assistant Secretary and Librarian*, R. G. Willott; *Committee Members*, S. Bircham, H. Hemsley, A. F. Allsopp and J. A. Richardson.

Rules drafted by a Rules Sub-Committee were unanimously adopted. Before the meeting closed a vote of thanks was given to Mr. Medland, retiring Chairman, and Mr. Lord, Secretary.

The future programme includes visits to a British Railways Locomotive Works, the Rugby Radio Station, the Sutton Coldfield Television Station and an Ironworks at Holwell.

The membership, now almost 80, has consistently supported the Committee. This gives every encouragement for the future well-being of the Leicester Centre. T. E. L.

Lincoln Centre

The 1952-53 winter session was completed on April 1st, when a party of 25 members visited Lysaghts Steelworks at Scunthorpe to see the many and varied processes used in making steel.

During the session, talks were given on such subjects as cable design, signalling systems, colour photography, works control procedure and tape recorders. An afternoon's visit to the railway works at Doncaster was also included in the programme.

For the second time our member, Mr. J. Bedford, has won one of the Institution prizes for the best paper of the year with his paper on "V.H.F. Aerials and Transmission Lines" which he presented to the Lincoln Centre in January, 1952.

At the Annual General Meeting held on 2nd March, 1953, the following members were elected the Centre's officers for the forthcoming session:—

Chairman, Mr. J. Rossington; *Vice-Chairman*, Mr. L. Atkin; *Secretary*, Mr. J. E. Sharp; *Treasurer*, Mr. A. E. Clayton; *Committee*, Messrs. R. H. E. Found, R. J. Goodman, J. F. B. Lewtas and C. R. White. J. E. S.

London Centre

The London Centre held their 16th Annual General Meeting at the Lecture Theatre of the Institution of Electrical Engineers on Wednesday, the 27th of May, 1953. There were many ex-members and visitors present on the occasion of the 21st anniversary of the formation of the London Centre. After the election of Officers for Committee, addresses were given by the President of the Associate Section, Col. C. E. Calveley, O.B.E., B.Sc., M.I.E.E.; Mr. C. W. Brown, A.M.I.E.E., the first President of the then Junior Section; Mr. H. R. Harbottle, O.B.E., B.Sc.(Eng.), D.F.H., M.I.E.E., a past President; Mr. H. Faulkner, C.M.G., B.Sc., M.I.E.E., Chairman of the Senior Section Council, and Mr. R. S. Phillips, M.I.E.E., C.R.E. of the L.P.R. This was followed by an excellent paper, "Some Applications of Electronics to Telecommunications," read by Col. Calveley, which was of utmost interest. In this paper, the President advanced from early principles of electronics to the latest developments of electronics in the field of television and the electronic director equipment. Demonstrations were given on a most impressive array of test gear and equipment.



THE SECOND RADIO AND MODELS EXHIBITION.

At the Annual General Meeting, the following officers were elected: *Chairman*, A. G. Welling; *Vice-Chairman*, A. W. Britton; *Treasurer*, W. C. Peck; *General Secretary*, P. Sayers; *Assistant Secretary*, W. J. Black; *Librarian*, F. E. Baker; *Visit Secretary*, B. C. Hatch; *Radio Secretary*, H. E. Warren; *Editor*, E. W. Bridle.

Mr. F. C. G. Greening, B.Sc., A.M.I.E.E., always a great help, made it known that he would be the Liaison Officer for the coming session.

The second Radio and Models Exhibition took place on the 7th, 8th, and 9th of May, 1953, and although the number of exhibits and visitors was not up to expectations, the exhibition on the whole was a success. Mr. J. J. Edwards, B.Sc., M.I.E.E., Regional Engineer, L.T.R., kindly deputised for Mr. W. S. Procter, M.I.E.E., Chief Regional Engineer L.T.R., in opening the Exhibition, and on the last day Mr. R. S. Phillips, M.I.E.E., Chief Regional Engineer, L.P.R., presented the prizes to the successful members.

The lecture programme for the first four months of the forthcoming session has been arranged as follows:—

"Picture Telegraphy," by Mr. H. S. Pizey, on 23rd September; "Equipping a New Exchange," by Mr. A. W. Lee, on 15th October; "Aspects of TV Transmission," by Mr. Worswick (B.B.C.), on 10th November; "A New Observation Circuit," by Mr. C. S. Wicken, on 12th December.

The first and last of these papers are to be read by Associate Section Members. E. W. B.

Tunbridge Wells Centre

The Tunbridge Wells Centre held their Annual General Meeting on the 13th May, 1953. The Officers elected for 1953-54 Session were as follows:—

Chairman, G. Kingswood; *Secretary*, E. L. English; *Treasurer*, F. W. Archer; *Committee*, Messrs. H. W. Avis, T. W. Bowes, R. W. Charman, R. S. Kemp, J. A. V. Sparrowe, R. W. Winn; *Auditors*, Messrs. P. R. Gallard, K. H. J. Muggridge.

Under "Future Activities," a lively discussion took place and our 1953/54 Programme is now being arranged accordingly. It is intended to make a local award for the best paper given by an Associate member during the 1953/54 session.

A hearty vote of thanks was passed to Mr. A. E. Chapman (Treasurer 1944-1949, Chairman 1949-1953) who now leaves us upon his promotion.

We now have a membership of 110 and sincerely hope that members will take full advantage of all facilities. The officers of the Centre are always available to give advice and accept any constructive criticisms. E. L. E.

Staff Changes

Promotions

Name	Region	Date	Name	Region	Date
<i>Snr. Exec. Engr. to Regl. Engr.</i>			<i>Inspector to Asst. Engr.</i>		
Coleman, W. L. A.	E-in-C.O. to Mid. Reg.	2.3.53	Myatt, E.	Mid. Reg.	1.4.53
<i>Snr. Exec. Engr. to Tel. Manager</i>			King, G. O.	L.P. Reg.	11.3.53
De Jong, N. C. C.	W.B.C. to N.W. Reg.	3.6.53	Craigie, F. R.	H.C. Reg.	31.3.53
Peddle, H. W.	Mid. Reg.	11.5.53	<i>Snr. Sc. Offr. to Prin. Sc. Offr.</i>		
<i>Snr. Exec. Engr. to Depy. Tcl. Manager</i>			Roberts, F. F.	E-in-C.O.	18.2.53
Revell, H. J.	Scot.	7.3.53	Thomson, W. E.	E-in-C.O.	18.2.53
<i>Exec. Engr. to Snr. Exec. Engr.</i>			<i>Sc. Offr. to Snr. Sc. Offr.</i>		
Turner, D.	E-in-C.O.	23.2.53	Reynolds, F. H.	E-in-C.O.	20.2.53
Broadhurst, J. H.	E-in-C.O.	11.3.53	Lawson, R. W.	E-in-C.O.	20.2.53
Pitts, H. E.	H.C. Reg.	11.3.53	Parsons, R. L.	E-in-C.O.	20.2.53
Fleetwood, C. H. J.	E-in-C.O.	23.3.53	<i>Asst. Expl. Offr. to Expl. Offr.</i>		
Heron, K. M.	E-in-C.O.	23.3.53	Henderson, J. C.	E-in-C.O.	23.3.53
Trussler, H.	S.W. Reg. to E-in-C.O.	7.4.53	Sargent, D. J.	E-in-C.O.	23.3.53
Wash, G. H.	E-in-C.O.	19.5.53	Young, E. J.	E-in-C.O.	23.3.53
<i>Asst. Engr. to Exec. Engr.</i>			Dunk, Miss J. O.	E-in-C.O.	4.4.53
Porter, J. M.	N.Ire. Reg.	2.3.53			
Hay, H. E.	N.E. Reg.	17.4.53			

Transfers

Name	Region	Date	Name	Region	Date
<i>Snr. Exec. Engr.</i>			<i>Asst. Engr.—continued</i>		
Stead, L. G.	E-in-C.O. to Ministry of Supply	1.1.53	Hannah, A.	E-in-C.O. to Australian P.O.	24.11.49
<i>Exec. Engr.</i>			Edwards, H. W. F.	E-in-C.O. to Australian P.O.	12.1.50
Brett, G. E.	E-in-C.O. to L.T. Reg.	1.5.53	Millsom, H. W.	E-in-C.O. to Australian P.O.	18.12.49
Ridlington, A. D. V.	E-in-C.O. to G.C.H.Q.	27.9.52	Robbins, R. A. D.	E-in-C.O. to P. & T. Dept. Nyasaland	2.10.50
Thirsk, R. D.	E-in-C.O. to N.W. Reg.	13.4.53	Chambers, J.	Scot. to Australian P.O.	24.11.49
<i>Asst. Engr.</i>			Dick, G. C.	E-in-C.O. to Scot.	31.5.53
Warwick, H. A.	E-in-C.O. to H.C. Reg.	29.3.53	Coles, G. E.	E-in-C.O. to H.C. Reg.	26.5.53
Northall, B. V.	E-in-C.O. to N.E. Reg.	26.4.53	<i>Expl. Offr.</i>		
Trask, G. W. F.	E-in-C.O. to Australian P.O.	20.9.49	Allen, T. K.	E-in-C.O. to Australian P.O.	13.10.49
Green K. J.	H.C. Reg. to P. & T. Dept. East Africa	14.2.48	<i>M.T.O. II</i>		
Sims, G. H.	E-in-C.O. to Australian P.O.	24.11.49	Huxley, R. T.	E-in-C.O. to L.T. Reg.	1.4.53

Retirements and Resignations

Name	Region	Date	Name	Region	Date
<i>Snr. Exec. Engr.</i>			<i>Asst. Engr.—continued</i>		
Reeves, L. N.	E-in-C.O. (Resigned)	7.5.53	Godliman, D. E.	E-in-C.O. (Resigned)	27.5.53
<i>Exec. Engr.</i>			<i>Inspector</i>		
Allies, H. J.	N.E. Reg.	31.3.53	Bryan, T. H.	L.P. Reg.	1.4.53
Alderton, A. G.	N.E. Reg.	21.4.53	Brooks, W.	N. Ire. Reg.	31.3.53
Moore, H. J.	L.T. Reg.	30.4.53	O'Sullivan, D. B. A.	S.W. Reg.	8.4.53
Shipperbottom, F.	N.W. Reg.	28.3.53	Blackie, J.	N.E. Reg.	30.4.53
Huntington, F.	N.W. Reg.	14.5.53	Harriott, W. S.	N.E. Reg.	29.4.53
<i>Asst. Engr.</i>			Pickering, E.	H.C. Reg.	4.10.53
Ottaway, A. C.	L.P. Reg.	10.3.53	Wilson, L. J.	H.C. Reg.	22.2.53
Lancaster, A. E.	N.E. Reg.	16.3.53	Parsons, E.	H.C. Reg.	4.4.53
Robson, S.	N.E. Reg.	17.4.53	Robinson, F. S. P.	Mid. Reg.	18.5.53
Parker, J.	N.E. Reg.	31.3.53	<i>Prin. Sc. Offr.</i>		
Earnshaw, E.	N.E. Reg.	2.3.53	Beckman, R.	E-in-C.O. (Resigned)	16.5.53
Dukes, H. B.	S.W. Reg.	3.4.53	<i>Asst. (Sc.)</i>		
Ramsden, W. E.	N.E. Reg.	20.4.53	Durbridge, K. J. B.	E-in-C.O. (Resigned)	30.4.53
Miles, H.	N.W. Reg.	31.5.53	<i>Regl. M.T.O.</i>		
Strathern, J.	Scot.	16.4.53	Daft, W. E.	L.T. Reg.	31.3.53
Hampton, J. H. W.	W.B.C.	25.4.53			
Power, W.	E-in-C.O.	31.3.53			

Deaths

Name	Region	Date	Name	Region	Date
<i>Exec. Engr.</i> Goddard, J. R.	E.T. Exec.	16.5.53	<i>Inspector</i> Shrimpton, O.	L.T. Reg.	6.3.53
<i>Asst. Engr.</i> Veneer, A. G.	H.C. Reg.	21.5.53			

DRAUGHTSMEN

Retirement			Transfer		
Name	Region	Date	Name	Region	Date
<i>Ldg. D'man.</i> Dadswell, J. H.	E.-in-C.O.	17.2.53	<i>D'man.</i> Harrison, A. F.	L.T. Reg. to E.-in-C.O.	4.5.53

CLERICAL GRADES

Retirement

Name	Region	Date
<i>Snr. Exec. Offr.</i> Foord, F. C.	E.-in-C.O. (Health Grounds)	9.4.53

BOARD OF EDITORS

H. FAULKNER, C.M.G., B.Sc., M.I.E.E., F.I.R.E., Chairman.
 W. WEST, O.B.E., B.A., M.I.E.E.
 L. F. SCANTLEBURY, Whit.Sch., A.C.G.I., D.I.C., M.I.E.E.
 D. A. BARRON, M.Sc., A.M.I.E.E.
 H. G. BEER, Whit.Sch., A.C.G.I.
 E. DAVIS, A.M.I.E.E.
 L. CHANT.
 G. E. STYLES, A.M.I.E.E., Managing Editor.
 W. A. HUMPHRIES, A.M.I.E.E.
 J. P. HARDING, B.Sc.(ENG.).
 A.M.Inst.C.E., A.M.I.E.E. } Assistant Editors.
 A. J. HUTCHISON, Secretary-Treasurer.

Binding Cases

Cases for binding are available, and may be obtained from the Local Agents for 3s. Subscribers can have their copies of volumes bound, at a cost of 10s. 6d., by sending the complete set of parts to the Local Agents or to the *P.O.E.E. Journal*, Engineer-in-Chief's Office, Alder House, Aldersgate Street, London, E.C.1. Orders for binding for Vols. 1-19 should indicate whether the original binding case with black lettering, or the later pattern with gold, is required. Cases with gold lettering are the only type stocked from Vol. 20 onwards.

Back Numbers

The price of the JOURNAL, which is published quarterly, is 2s. 6d. (2s. 9d. post free) per copy, or 1 ls. per annum, post free. Back numbers can be supplied, subject to availability of stocks, at 2s. 6d. each (2s. 9d. post free). Orders for back numbers may be sent to the *P.O.E.E. Journal*, Engineer-in-Chief's Office, Alder House, Aldersgate Street, London, E.C.1, or to the Publishers.

Employees of the British Post Office can obtain the *Journal* through Local Agents at the reduced price of 2s. per copy.

Advertisements

All communications relating to space reservations should be addressed to the Advertisement Editor, *P.O.E.E. Journal*, Alder House, Aldersgate Street, London, E.C.1. Communications regarding advertisement copy, proofs, etc., should be addressed to the Publishers, Messrs. Birch & Whittington (Prop. Dorling & Co. [Epsom], Ltd.), 49 Upper High Street, Epsom, Surrey.

Copyright

The entire contents of this JOURNAL are covered by general copyright, and special permission is necessary for reprinting long extracts, but Editors are welcome to use not more than one-third of any article, provided credit is given at the beginning or end thus: "From the *Post Office Electrical Engineers' Journal*."

The Board of Editors is not responsible for the statements made or the opinions expressed in any of the articles in this JOURNAL, unless such statement is made specifically by the Board.

Communications

All communications should be addressed to the Managing Editor, *P.O.E.E. Journal*, Engineer-in-Chief's Office, Alder House, Aldersgate Street, London, E.C.1. Telephone: HEADquarters 1234. Remittances should be made payable to "The *P.O.E.E. Journal*" and should be crossed "& Co."

Fine wires in telecommunication & electronic equipment
need



the only vitalised pure rosin cored Solder

ACTOL is the only fast-working cored solder which is chlorine free. Its *pure rosin* flux is vitalised by an exclusive process to increase its wetting power without altering its chemical properties ; it contains no additive. Furthermore, ACTOL has the unique Enthoven stellate core for rapid wall solder collapse and faultless fluxing. ACTOL leaves a hard, non-corrosive residue

of maximum insulation resistance. A.I.D. approved. In all standard tin/lead alloys, 10-22 s.w.g.

Please send for a sample of ACTOL or ask one of our technical advisers to call.

Perfect joints in precision instruments and delicate components need ACTOL, the only vitalised pure rosin cored solder.

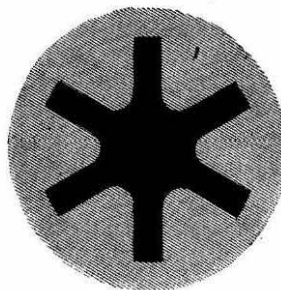

Developed and manufactured at the Enthoven Solder Factory

MARKETED BY ENTHOVEN SOLDERS LTD., 89, UPPER THAMES ST., LONDON, E.C.4.

INDEX TO ADVERTISERS

	PAGE
Airmec, Ltd.	xxviii
Alton Battery Co., Ltd., The	vii
Automatic Coil Winder & Electrical Equipment, Co. Ltd.	xxiii
Automatic Telephone & Electric Co., Ltd.	xii, xvi
Bennett College, The	ii
British Electric Resistance Co., Ltd., The	xxvii
Edison Swan Electric Co., Ltd., The	xxix
E.M.I. Institute	ii
Enthoven Solders	iii
Ericsson Telephones, Ltd.	xxii
General Electric Co., Ltd., The	xiii-xiv, xix-xx
Great Northern Telegraph Co., Ltd.	xxiv
Hackbridge Cable Co., Ltd.	xxiv
Hivac, Ltd.	iv
Jones, Walter	xxvii
Marconi's Wireless Telegraph Co., Ltd.	viii
Marconi Instruments	xv
Muirhead & Co., Ltd.	ix
Mullard, Ltd.	x
Neill, James, & Co., Ltd.	ix
Painton of Northampton	xi
Pirelli-General Cable Works, Ltd.	xxix
Pitman, Sir Isaac, & Sons, Ltd.	iv
Pye, Ltd.	xvii-xviii
Siemens Brothers & Co., Ltd.	xxi
Smith, Frederick, & Co.	ii
Standard Telephones & Cables, Ltd.	v-vi
Sullivan, H. W., Ltd.	xxv
Telephone Manufacturing Co., Ltd.	xxiii
Tungstone Products, Ltd.	xxvi
Turner, Ernest	xxviii
Westinghouse Brake & Signal Co., Ltd.	xxv
Winn & Coales, Ltd.	ii

PITMAN'S

for Technical Books



Information Theory and its Engineering Applications

By D. A. Bell, M.A., B.Sc. (Oxon.), M.I.E.E.; Reader in Electro-magnetism in the University of Birmingham. This important new book gives an account of the theory underlying modern developments in telecommunications and automatic control systems, and of the practical applications of the theory in telegraphy, telephony, radar storage-systems and television. With numerous diagrams. 20/- net.

Generation, Transmission and Utilization of Electrical Power

By A. T. Starr, M.A., Ph.D., M.I.E.E. A revised and up-to-date edition of this book which has been written to meet the requirements of the revised "Electrical Power" syllabus of the Engineering Degree. 20/- net. "Its technical soundness and clear exposition of principles should ensure its success with teachers and students . . ."—ELECTRICIAN

PITMAN, Parker Street, Kingsway, London, W.C.2

SUB-MINIATURISATION

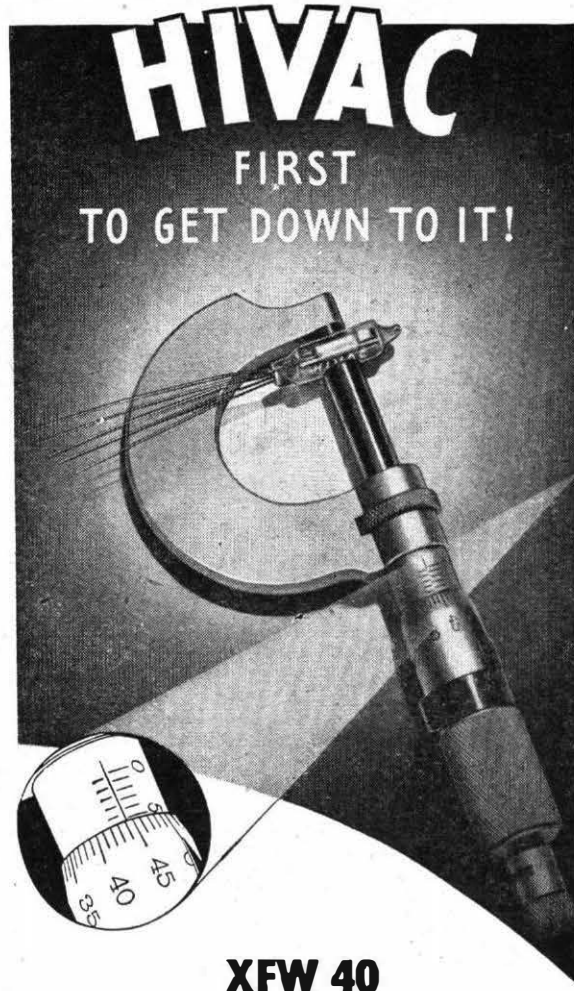

XFW 40

Beam Tetrode Subminiature Amplifier
with still lower filament current

TYPICAL OPERATION

Filament Voltage	0.625v
Filament Current	10mA
H.T. Supply Voltage	22½v
Anode Load	1 to 2MΩ
Screen Resistance	3MΩ
Stage Gain	32

The maximum cross-section is only 8mm. by 6mm. with a glass length of 27.0mm.

HIVAC
THE SCIENTIFIC
VALVE

The most modern small flat subminiature voltage amplifier for hearing aids and other small electronic equipment.

Hivac Ltd.

Telephone: HAF 2655
GREENHILL CRESCENT, BARNOW ON THE HILL, MIDDLESEX

Coronation telecommunications

Standard Telephones and Cables Limited are proud to have been chosen to provide telecommunication systems and equipment which were in service on the occasion of the Coronation of Her Majesty Queen Elizabeth II.



A *Standard's direct contribution to the Coronation included a special sound reinforcement system in Westminster Abbey and sound reproduction and dissemination with public address facilities along a major part of the route controlled by the Ministry of Works as indicated by the bold lines on the route map.*



B *Special large tube coaxial television cable between London and Birmingham by Standard.*



C *Standard coaxial television cable between Birmingham and Manchester.*



D *Standard vestigial side-band television equipment on the Birmingham Manchester section of the network.*



E *The latest London to Wenvoe link includes Standard coaxial cables.*



F *At Wenvoe, a television sound transmitter by Standard.*



G *Standard microwave television radio link relaying all programmes between Manchester and Kirk o'Shotts.*



H *At Kirk o'Shotts, a television sound transmitter also by Standard.*



J *Under contract to the B.B.C., and as a direct contribution to the Coronation, S.T.C. were solely responsible for relaying the Coronation Television programmes from London to the Continent. Equipment which was installed and operated by S.T.C. comprised five Standard portable S.H.F. radio links as supplied to the B.B.C. for numerous outside broadcasts since 1950. Monitoring equipment by **Kolster-Brandes Ltd.**, an S.T.C. associate.*

In addition to the above, a "Standard" Mobile Direction Finder, type PV1B, was provided for the assistance of R.A.F. and R.C.A.F. fighter aircraft which took part in the Coronation Fly-past.



Standard Telephones

(TELECOMMUNICATION)

Connaught House, Aldwych,

Cairo

Dublin

Johannesburg

by *Standard*

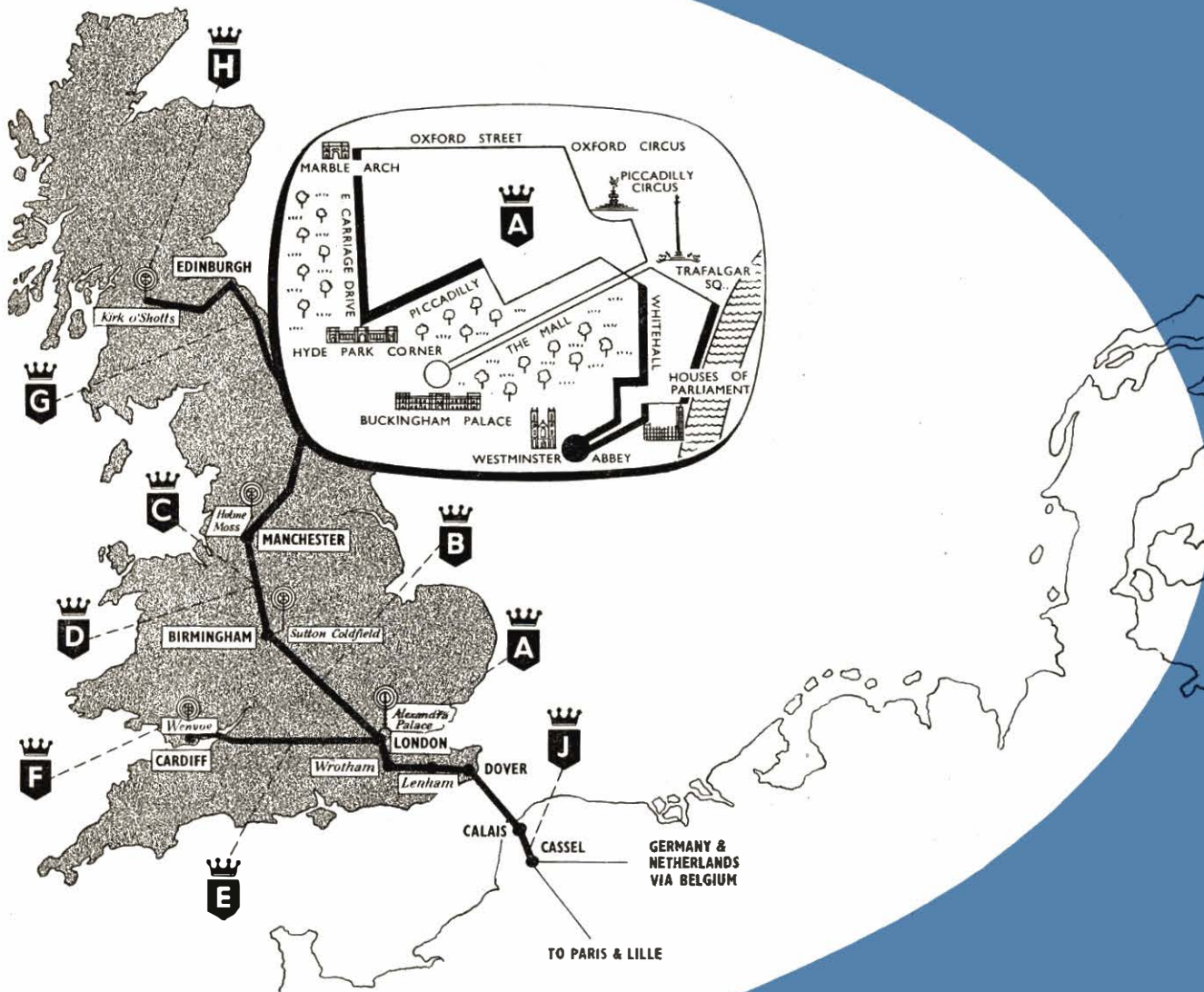

and Cables Limited

ENGINEERS)
London, W.C.2, England

Karachi • New Delhi • Salisbury

Right round the world, men know what Alton means. A storage battery—with a distinctive merit entirely its own. Where can distinction lie, in an era of rigid battery standardisation? One answer is that, in Hampshire, Alton means something else—a little countrytown. A town with a busy, neighbourly life within its boundaries, and the peace of lovely and unspoilt countryside beyond. A place where the sky is clean and growing things do well: flowers and fruit and children; a woman's pride in the home she makes—a man's in the skills of his trade. Making something better than 'well enough' is a habit that grows strongly in Alton soil. And Alton batteries are made by Alton men.

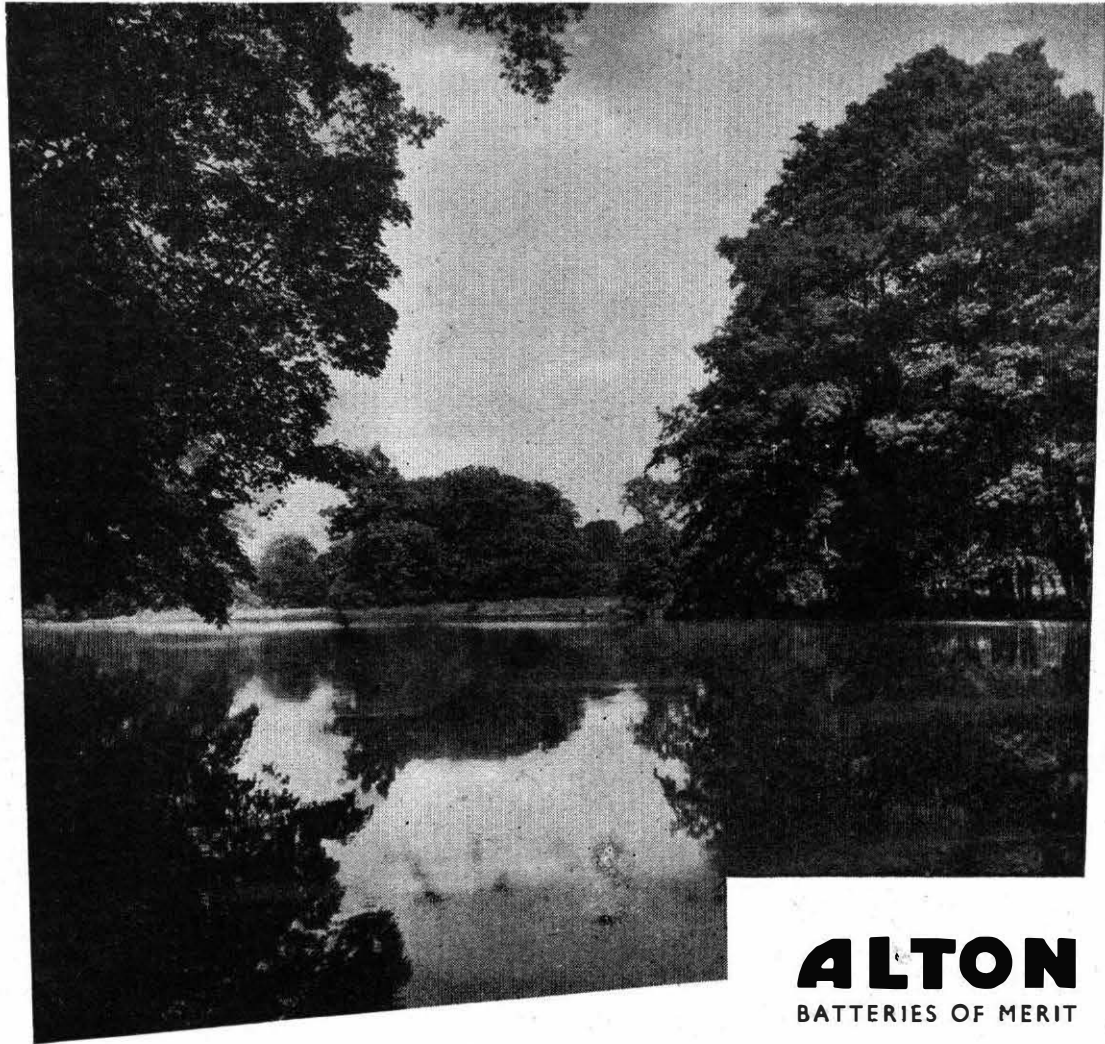

ALTON
BATTERIES OF MERIT

Alton stationary batteries: 10 to 15,000 Ah. Also in regular production, renewal plates for all makes of battery, British and Continental

A25A

The Alton Battery Company Limited · Alton · Hampshire · Telephone: Alton 2267 and 2268 Telegrams: Battery, Alton

MARCONI communication systems

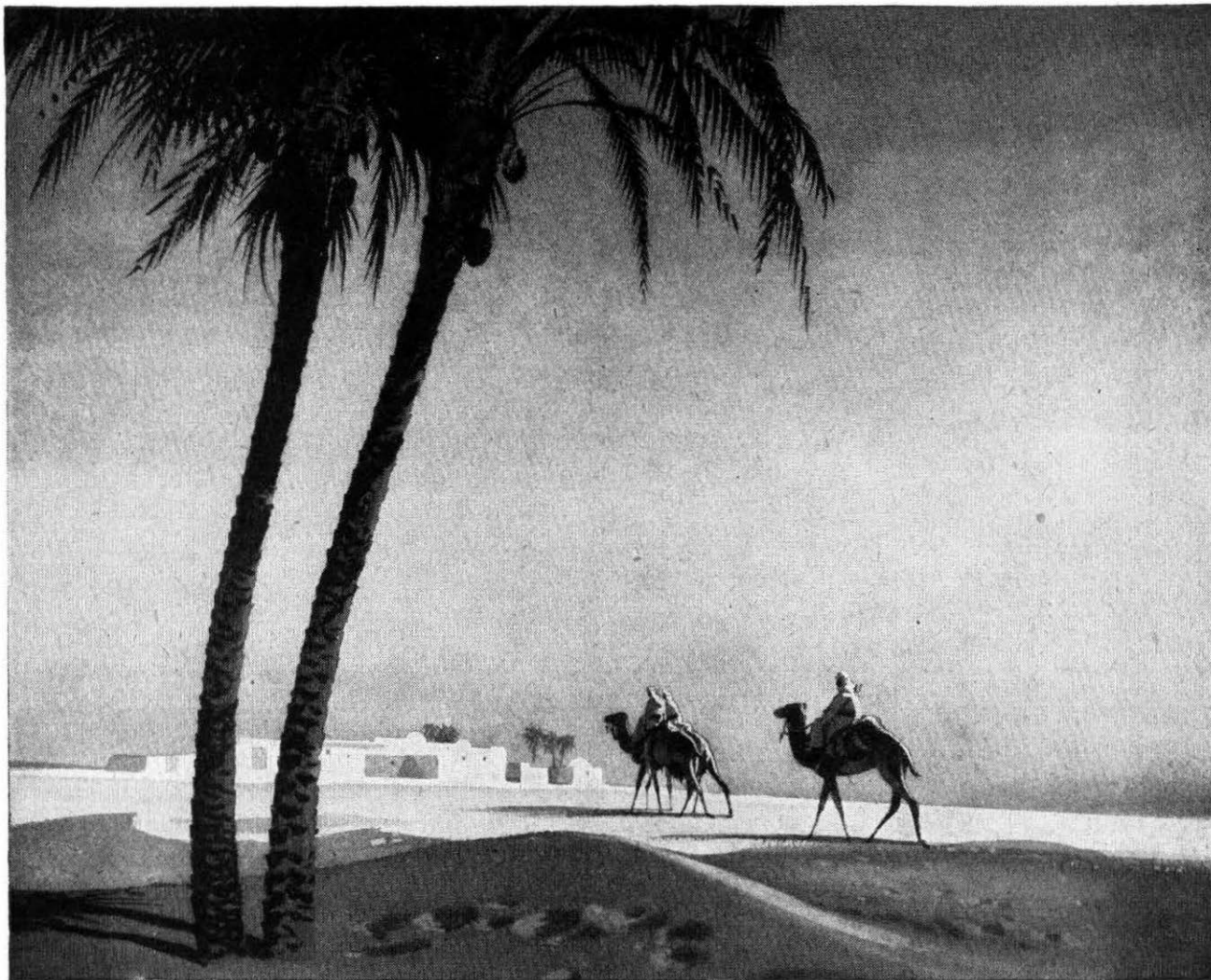

serve mankind

Communications . . . across the wastes of desert and ocean, and through impassable swamps and jungles . . . were largely unsolved until Marconi invented the miracle of radio. At one stroke he substituted ease for difficulty, and opened up a new era in the history of

man. For over 50 years the Company which Marconi founded has made communications its business. Its experience in this field is unique. If you have a communications problem of any sort, anywhere, Marconi engineers are entirely at your service.



SURVEYED



PLANNED



INSTALLED

MARCONI'S WIRELESS TELEGRAPH COMPANY LTD • CHELMSFORD • ESSEX



**THIS INTERESTING QUARTERLY
WILL BE MAILED *FREE*
TO ANY PART OF THE WORLD
POST THIS COUPON TODAY**

MUIRHEAD & CO. LTD · BECKENHAM · KENT · ENGLAND

Please mail me, free of charge, your quarterly journal "technique"

NAME _____

POSITION _____

COMPANY _____

ADDRESS _____

76

MUIRHEAD & CO. LTD · BECKENHAM · KENT · ENGLAND
PRECISION ELECTRICAL INSTRUMENT MAKERS

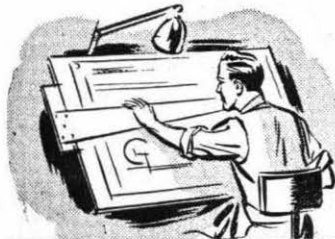

**Economy begins
at the
design stage . . .**

The latest developments in permanent magnet materials and techniques can effect remarkable economies, provided they are introduced at the design stage.

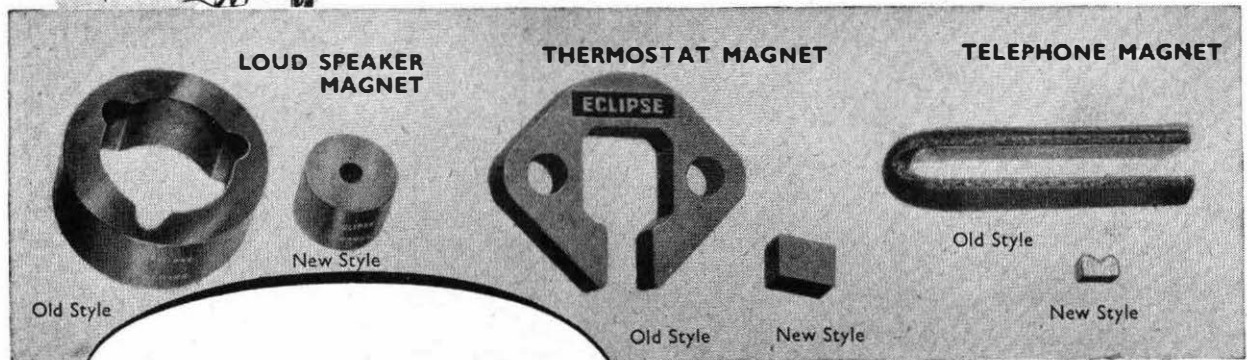

Send for Publication
P.M.131/51 "Design and
Application of Modern
Permanent Magnets"

Made by the makers of
"Eclipse" Permanent Magnet Chucks

Eclipse

**PERMANENT
MAGNETS**

JAMES NEILL & CO. (SHEFFIELD) LTD.
SHEFFIELD 11 ENGLAND

M.I.

a new
**INDEPENDENT SIDEBAND
RECEIVER**

**... developed to British Post Office
Specification**

THIS new Independent Sideband Receiver type GFR 552 is designed for operation on long-distance, point-to-point, short-wave radio links forming part of the international trunk network. On independent sideband working, the GFR 552 provides facilities for the reception of two single sideband signals, each 6 kc/s wide, one above and one below the frequency of a reduced-level pilot carrier. Each sideband will accommodate either two 3 kc/s wide telephony channels, or several voice frequency telegraph channels. The GFR 552 may also be used for reception of single sideband or double sideband transmission. In the case of the second application this receiver offers two advantages: firstly, the absence of non-linear distortion which occurs in normal D.S.B. receivers when signals are subjected to selective fading conditions; and, secondly, the ability to select upper or lower sideband for demodulation, dependent upon which is freer from adjacent channel interference. The circuit and chassis layout of the GFR 552 closely follows that of the Mullard Receiver GFR 551, which was based on a British Post Office design (Receiver, Radio No. 22).

Special features of the GFR 552 include a high order of oscillator stability and freedom from cross-modulation through which cross-talk between channels or inter-modulation between wanted and unwanted signals might occur. A brief technical summary is given below. More detailed information supplied on request.

FREQUENCY RANGE—4-30 mc/s.

NOISE FACTOR—better than 7 db over the band.

SIGNAL TO NOISE RATIO—25 db for 4 microvolts peak sideband input over the band.

SELECTIVITY—The response is flat within 2 db for sideband frequencies between 100 c/s and 6000 c/s. At 10 kc/s from the carrier frequency the response is -60 db relative to the pass band.

A.F.C.—The A.F.C. system operates effectively with a pilot carrier level of -26 db relative to 1 microvolt (which corresponds to a peak sideband level of 1 microvolt and a signal to noise ratio of 15 db).

NON-LINEAR DISTORTION—Third order intermodulation products which might result in cross talk between sidebands do not exceed -50 db relative to the sideband levels.

OUTPUT—Variable up to +14 db relative to 1 mW into 600 ohms.

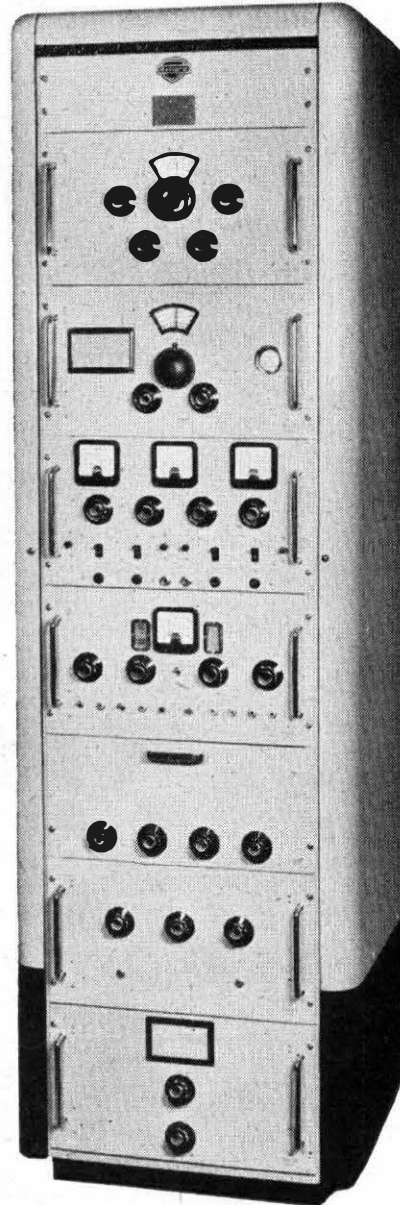

Mullard



SPECIALISED ELECTRONIC EQUIPMENT

MULLARD LIMITED, EQUIPMENT DIVISION, CENTURY HOUSE, SHAFTESBURY AVENUE, LONDON, W.C.2
(M1417)



By Appointment to the Professional Engineer....

ATTENUATORS · FADERS · STUD SWITCHES AND TOGGLE SWITCHES
WIREWOUND POTENTIOMETERS · HIGH STABILITY CARBON RESISTORS
WIREWOUND RESISTORS · PLUGS AND SOCKETS · TERMINALS
KNOBS DIALS AND POINTERS

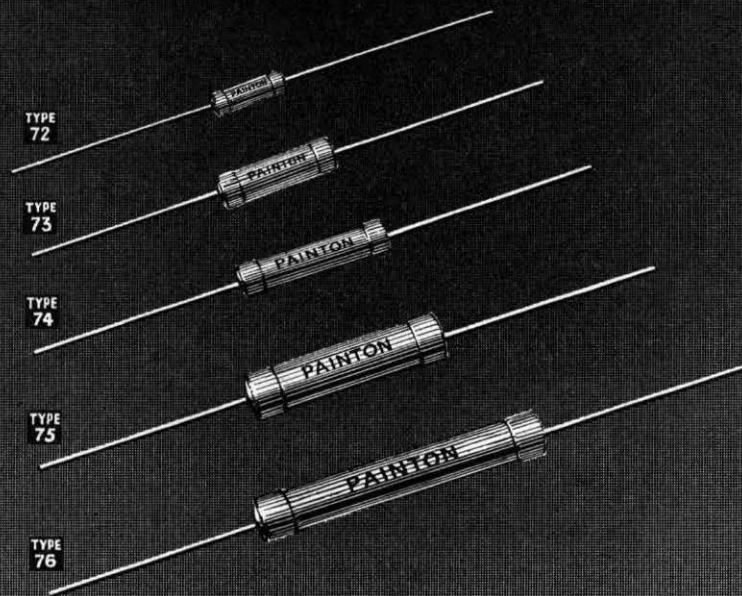

HIGH STABILITY CARBON RESISTORS

$\frac{1}{4}$ w, $\frac{1}{2}$ w, $\frac{3}{4}$ w, 1 w and 2 w types available at 1%, 2% or 5% Resistance Tolerance.
Complete range fully R.C.S.C. approved. For full details request Catalogue, Section E.

PAINTON
Northampton England

Selector Craft

The Type 32A selector was designed to ensure a high standard of performance and its success has been such that it is now the basic selecting mechanism in some 1700 public exchanges distributed in over 40 different countries of the world. In addition, the Type 32A selector is used in many thousands of Private Automatic Exchanges (P.A.X.) As a result of this vast experience, several improvements have been embodied into the original design and the Type 32A Mark II model may fairly be described as representing the highest peak of proved selector design yet achieved. In main automatic exchanges various automatic and manual testing devices operated by a small skilled staff are sufficient to ensure that, whatever the traffic, the selectors are maintained at their highest efficiency. In small exchanges, however, with their lighter loading, the equipment can be left completely unattended for long periods, as has been the normal practice for many years with R.A.X., U.A.X. and P.A.X. installations throughout the world. Lubrication is the only essential regular routine and this operation can be performed without removing selectors from their shelves or disturbing their adjustments. Regular observance of this simple routine ensures a high and consistent level of performance.

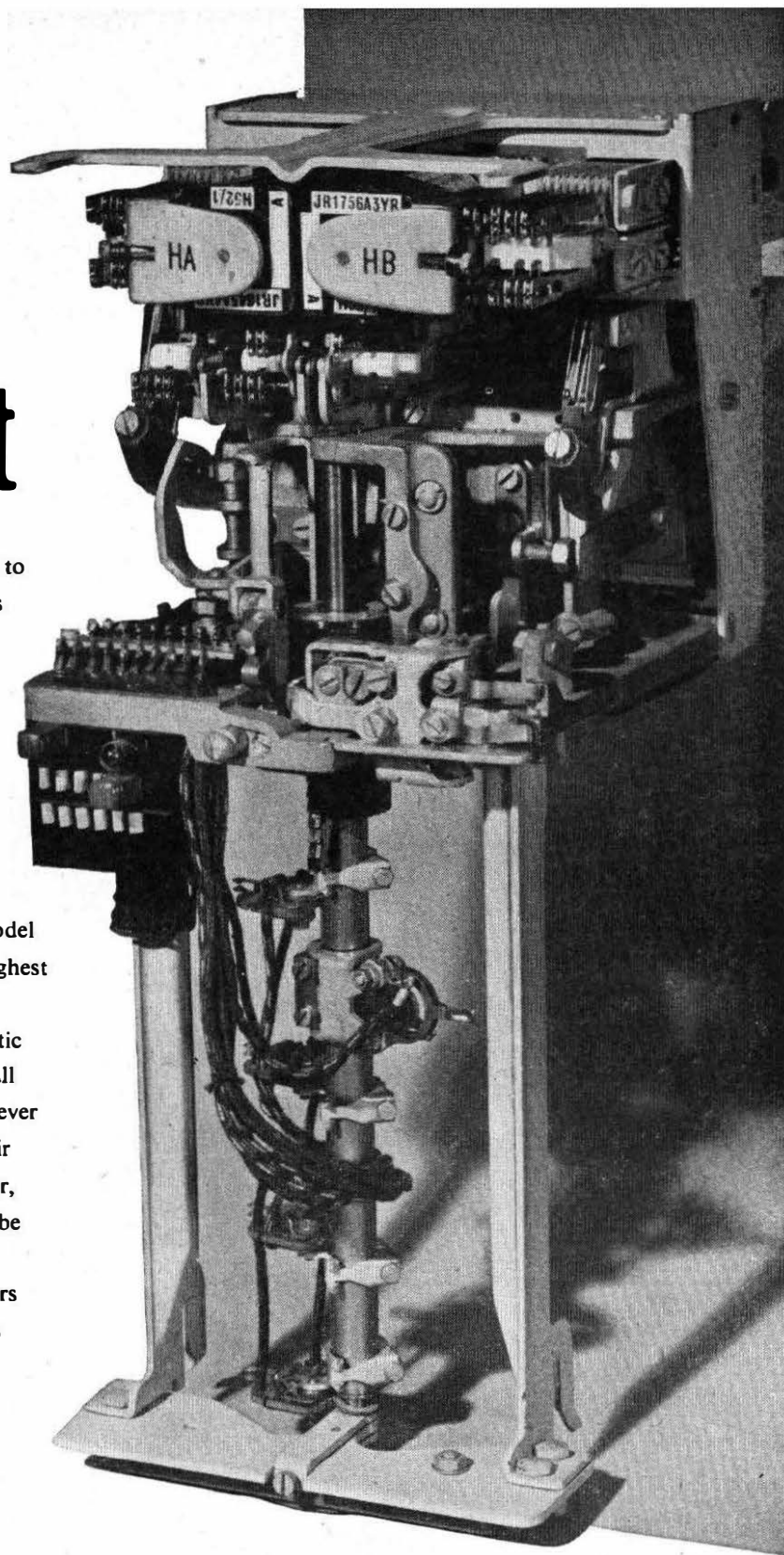

TYPE 32A MARK II SELECTOR

AUTOMATIC TELEPHONE AND ELECTRIC CO. LTD.

EXPORT DEPARTMENT: STROWGER HOUSE, ARUNDEL STREET, LONDON, W.C.2

Telephone: TEMple Bar 9262.

Cablegrams: Strowgerex London.

Strowger Works, Liverpool, England.



AT7781-A104

WHEN LINE OR CABLE

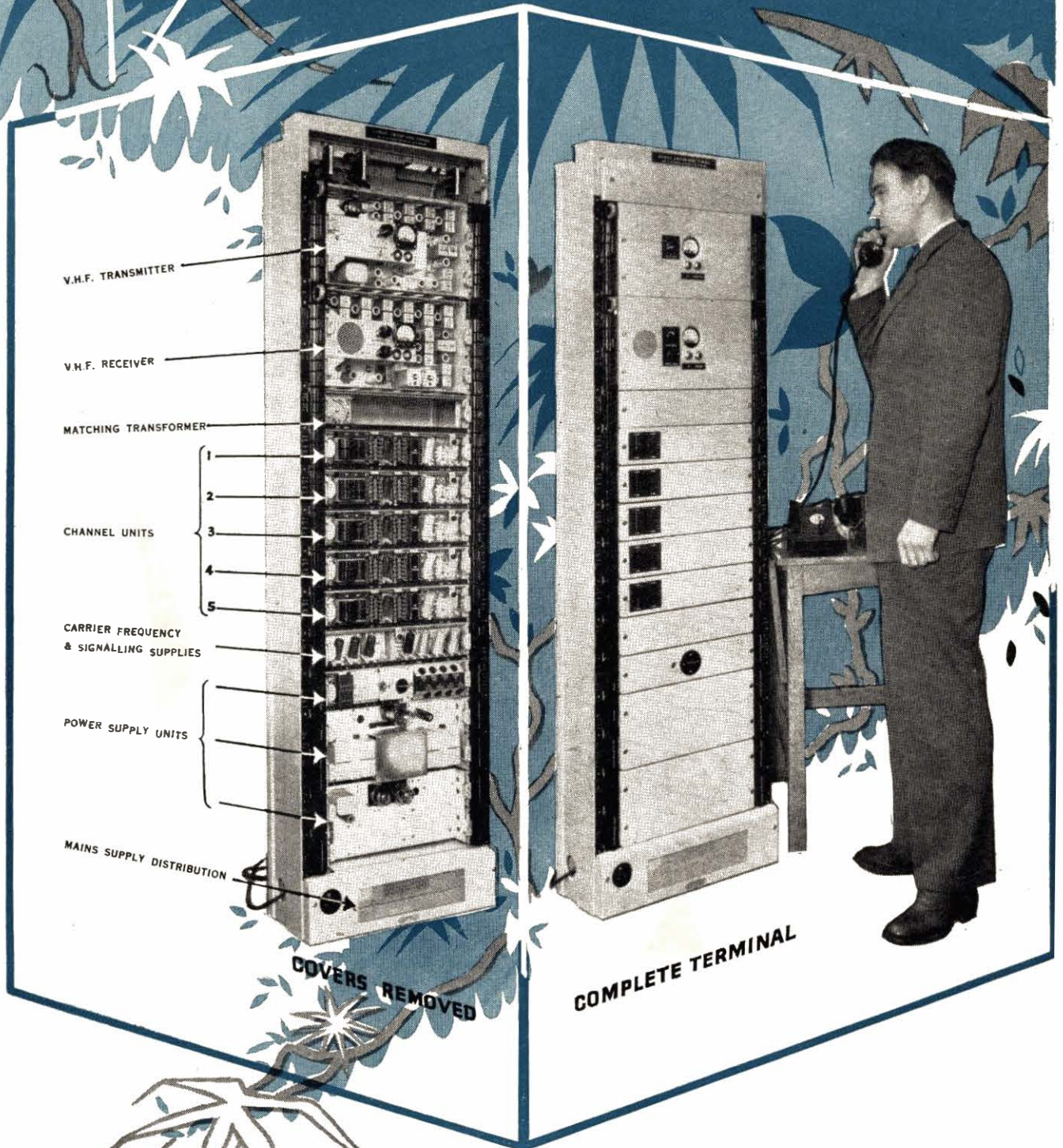

THE GENERAL ELECTRIC COMPANY LIMITED OF ENGLAND.



**SYSTEMS ARE
IMPRACTICAL OR UNECONOMICAL**

USE

G.E.C.

MULTI - CIRCUIT

JUNCTION RADIO EQUIPMENT

Small—inexpensive—available for quick delivery—this V.H.F. Radio Telephone equipment is especially valuable for the provision of small numbers of circuits. Up to five circuits are provided by frequency-division-multiplex operation over the frequency-modulated V.H.F. radio link.

Operating over a distance of 50 miles the total cost of a system consisting of two complete terminal equipments, aerials and feeder cables is less than the cost of the copper required to derive a single open-wire pair for the provision of equivalent facilities.

All panels of the equipment are of the slide-in type and can be removed in a few seconds for ease of maintenance.

ALSO AVAILABLE:—Single-circuit, 3-circuit and 12-circuit equipment for operation over open wire lines.
12-60 circuit equipment for operation over non-loaded carrier cables.
Coaxial cable terminal equipment for up to 16 super groups (960 circuits).
Coaxial cable systems for television and radar display relays.
Power line carrier equipment.
Wide-band V.H.F. and U.H.F. Trunk Radio systems for up to 720 speech circuits.

TELEPHONE, RADIO AND TELEVISION WORKS, COVENTRY

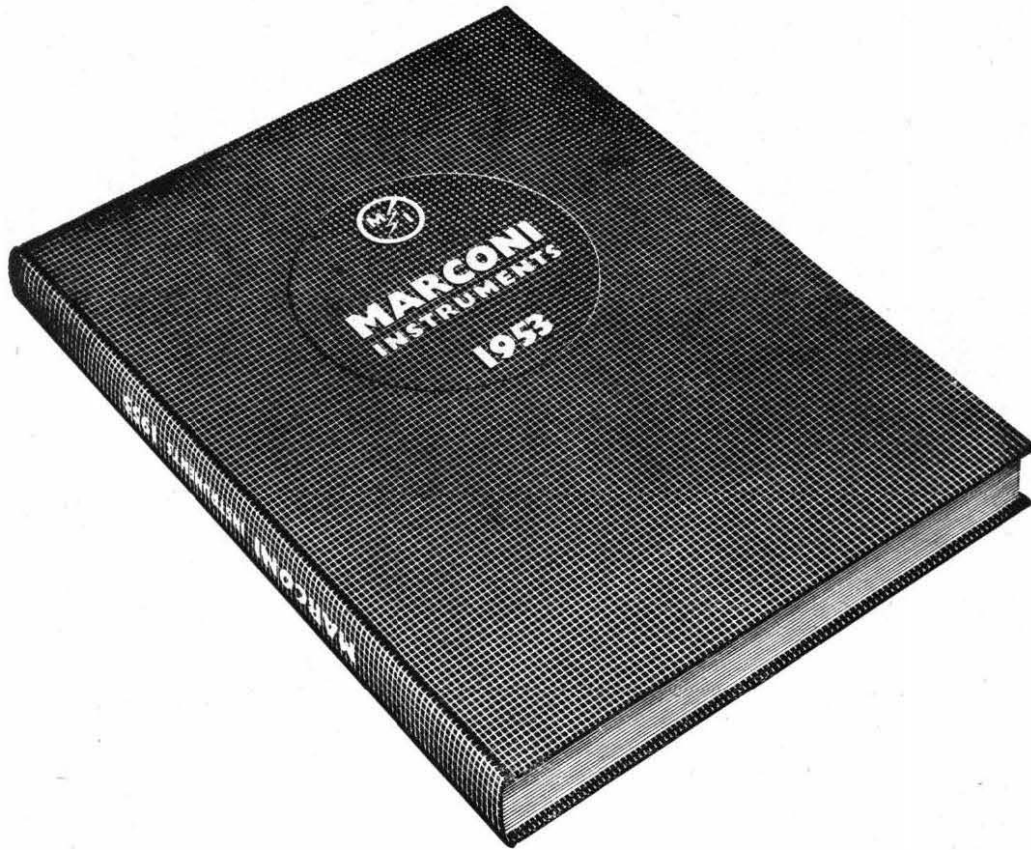

keep up-to-date with **MARCONI**

We would like to draw the attention of all our friends to the new instrument catalogue. This handsomely bound publication records the latest developments in the communication and industrial fields — as have our loose-leaf catalogues up to now. But techniques advance as Marconi research progresses, and for clarity's sake all available data has been re-cast in

the new format. We hope this will prove even more valuable to you than its predecessors.

If you are on our existing mailing list, you will have your new Marconi Instruments catalogue this month. But do jog our memory if, by chance, we overlook you — we want every executive who really needs one to have a copy.

MARCONI INSTRUMENTS

SIGNAL GENERATORS · BRIDGES · Q METERS · OUTPUT METERS · WAVE METERS
WAVE ANALYSERS · BEAT FREQUENCY OSCILLATORS AND INDUSTRIAL ELECTRONIC INSTRUMENTS

MARCONI INSTRUMENTS LIMITED · ST. ALBANS · HERTFORDSHIRE

Midland Office: 19 The Parade, Leamington Spa. Northern Office: 30 Albion Street, Kingston-upon-Hull. Export Office: Marconi House, Strand, London, W.C.2.

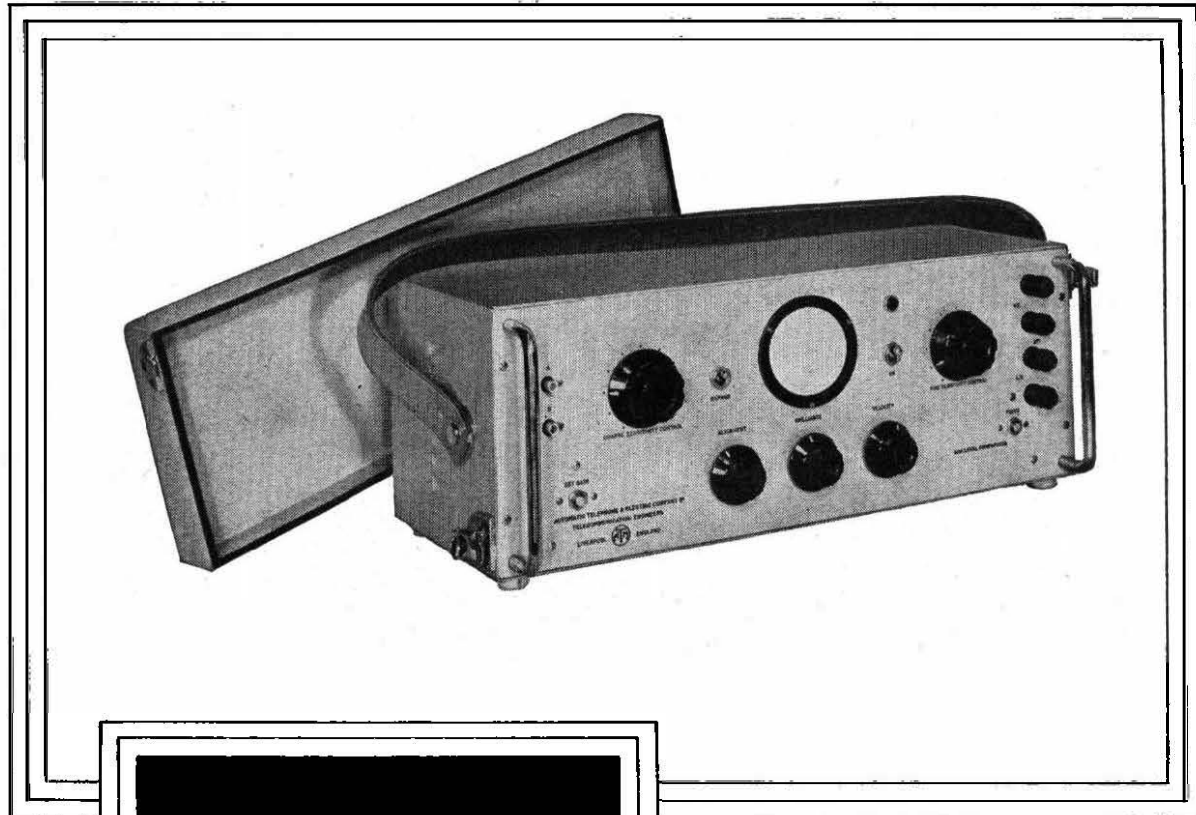

*A Precision
Tool for Line
Transmission
Measurements*

THIS INSTRUMENT, an electronic voltage comparator, was designed by Automatic Telephone & Electric Company to simplify the routine maintenance testing of line transmission equipment, whilst at the same time ensuring a high standard of reliable and accurate measurement. It is used to measure losses in channelling equipment, amplifier gains, crosstalk and harmonic distortion, and it possesses high

sensitivity over a wide frequency range. The development and manufacture of precision measuring apparatus is an important activity of the Company. By the use of such equipment, telephone administrations can ensure that their line transmission and radio circuits function with maximum reliability and economy.

AUTOMATIC TELEPHONE & ELECTRIC CO. LTD.

Radio and Transmission Division: STROWGER HOUSE, ARUNDEL STREET, LONDON, W.C.2. Telephone: TEMPLE BAR 9262. Cablegrams: STROWGEREX LONDON. *Manufacturers:* AUTOMATIC TELEPHONE & ELECTRIC CO. LTD., LIVERPOOL AND LONDON. TELEPHONE MANUFACTURING CO. LTD., ST. MARY CRAY, KENT.



AT.8491-BX105



FIRE, AMBULANCE

**MORE THAN
TWO-THIRDS
OF ALL THE
V.H.F. RADIO
TELEPHONE
EQUIPMENT
IN BRITAIN
IS SUPPLIED
BY PYE LTD.**

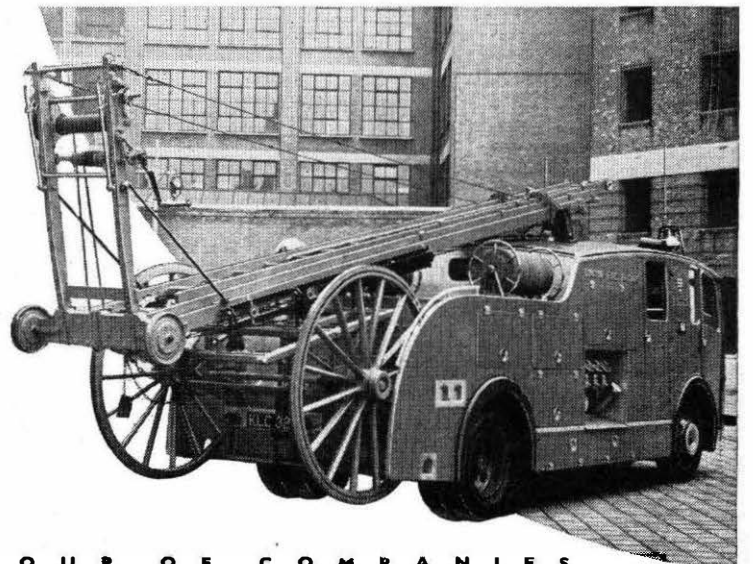
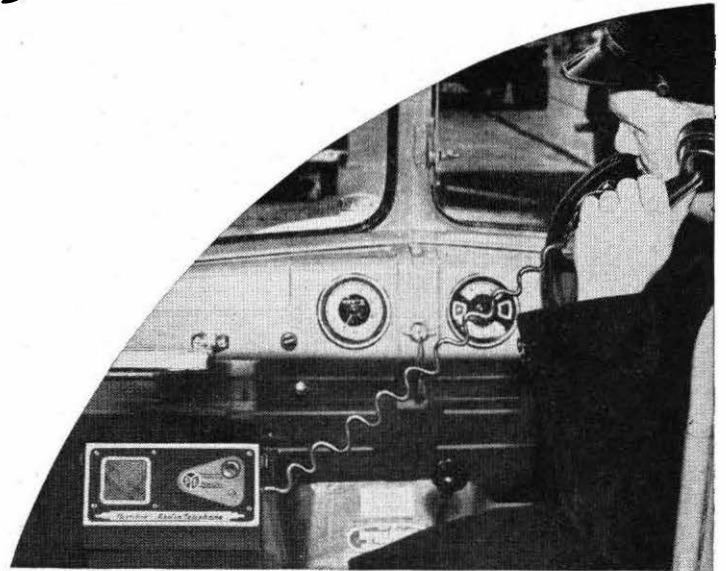

T H E P Y E G R O U P O F C O M P A N I E S

AND

POLICE SCHEMES

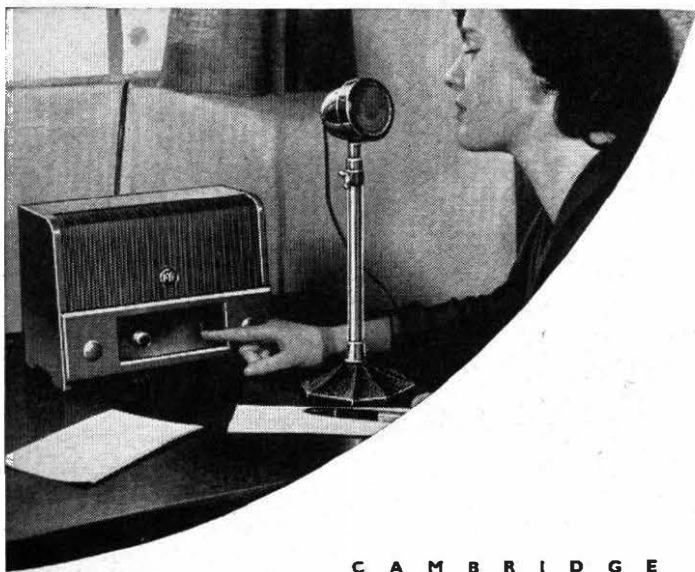
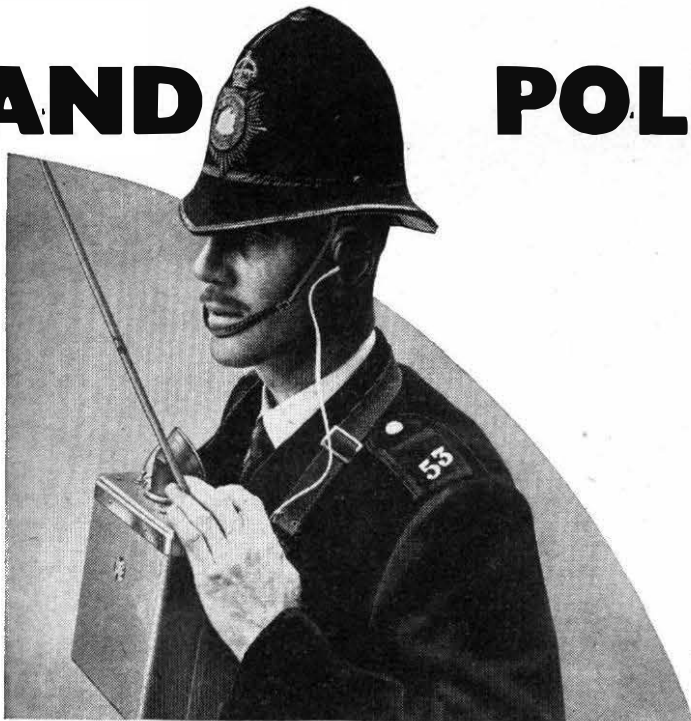

Pye V.H.F. radio telephone equipment provides immediate contact in circumstances which render normal telephone communication impossible. This makes it of special interest to local authorities, not only for their police and ambulance services, where speed and manoeuvrability are essential, but also for their fire services to give the controlling officer ready contact with all strategic points of an incident.

On data derived from installations already in use in fifty-four countries, it has been estimated **that three vehicles fitted with this apparatus can do the work of four without it.** In the case of police and ambulance services, it releases vehicles throughout the day for routine running and allows urgent calls to be rapidly dealt with by the most conveniently placed ambulance or police car. The equipment is designed to operate with the maximum economy consistent with the best service over the area covered—giving low mains consumption at the fixed station and the minimum demand on the mobile reporter battery.

CHOSEN BY THE
AUSTRALIAN POST OFFICE
AS THE STANDARD SWITCH
FOR LOCAL
PRODUCTION



The SE50 Selector is a major attainment in telephone apparatus design. Users of Strowger-system automatic exchanges throughout the world are fast accepting the SE50 as a standard,

SE50

SE50 Strowger Selectors will complete over 2,000,000 calls without readjustment or replacement of any major part.

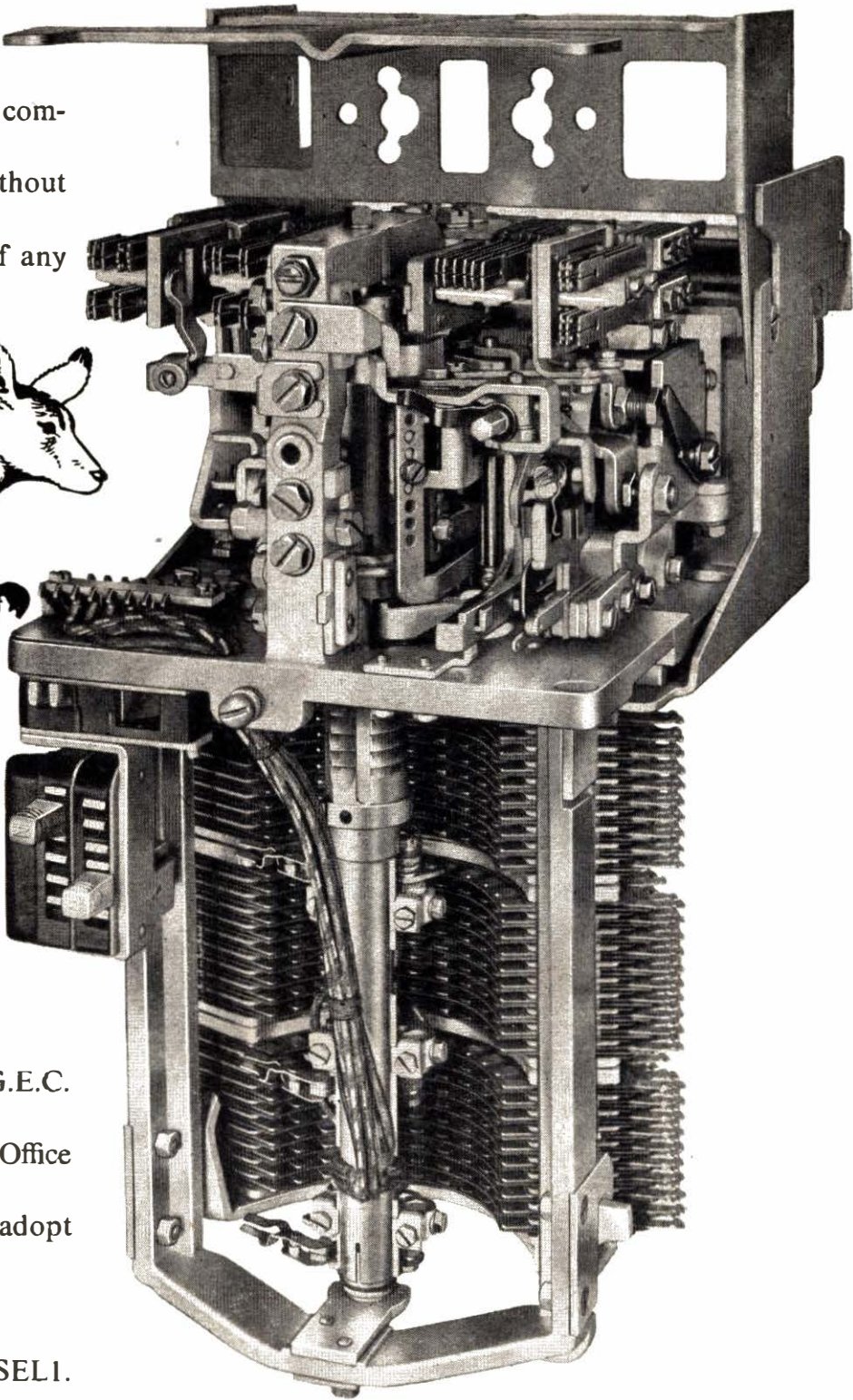
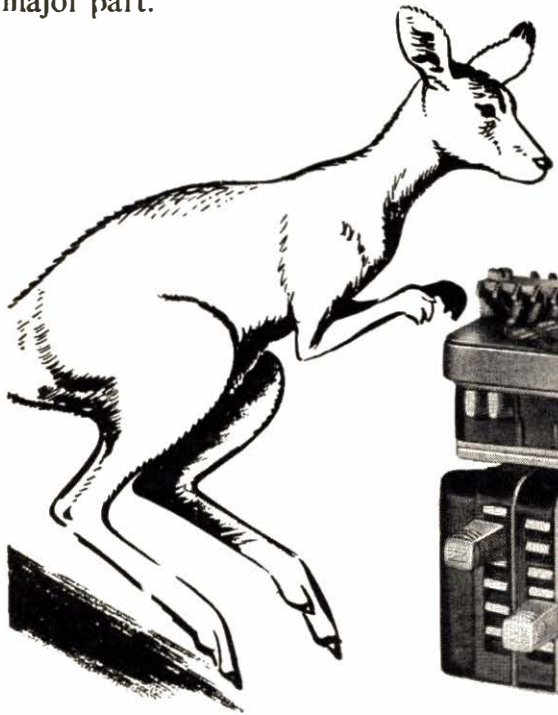

in common with other G.E.C. switches. The Australian Post Office is among the undertakings to adopt the SE50.

For full details write for leaflet SEL1.

SELECTOR

THE GENERAL ELECTRIC COMPANY LIMITED OF ENGLAND
TELEPHONE, RADIO AND TELEVISION WORKS, COVENTRY



PROGRESS AND ACHIEVEMENT

IN

Six Reigns

Established in 1858 (only 21 years after Queen Victoria came to the throne) Siemens Brothers & Co. Limited have, during six reigns — by continuous research and manufacturing experience — contributed in no small measure to the high standard attained in the electrical industry. To-day their products and achievements are known over the greater part of the globe.

SIEMENS

Telecommunication Engineers
Electric Cable Engineers
Electric Lamp & Lighting Specialists

Established 1858

SIEMENS BROTHERS & CO LIMITED
WOOLWICH LONDON S.E.18

SIEMENS ELECTRIC LAMPS & SUPPLIES LIMITED · LONDON · EC4

Cold Cathode Tubes



DEKATRONS

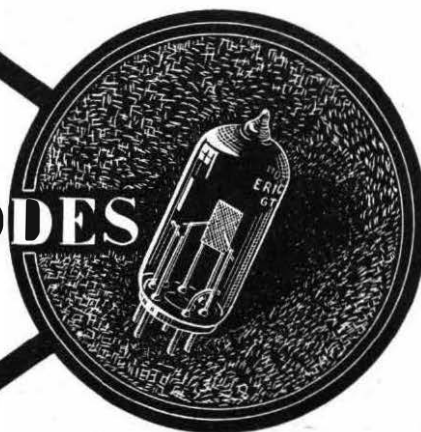

TRIGGER TETRODES



STABILISERS

*Descriptive Catalogue available on
application to:-*

WORKS:
BEESTON,
NOTTINGHAM
Beeston 54225



HEAD OFFICE:
22, LINCOLN'S INN FIELDS,
LONDON, W.C.2
HOLborn 6936

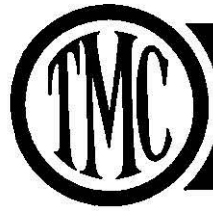
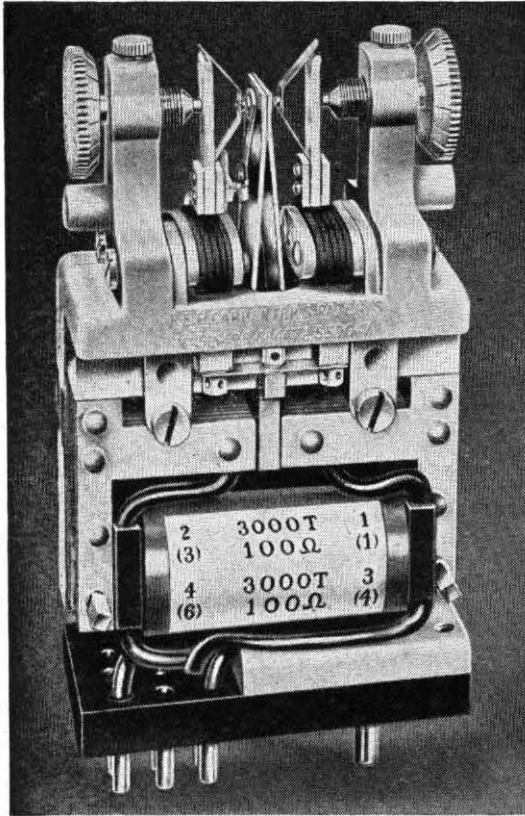

CARPENTER POLARIZED RELAY TYPE 4

The chief characteristics of this relay are low transit time—high contact pressure—freedom from contact chatter and positional error—high sensitivity—stability—symmetrical action—and ease of adjustment.

On V.F. dialling systems its use facilitates the design of sensitive receiving equipment, and on trunk telephone circuits the relay's high sensitivity enables it to respond to D.C. dialled impulses received over unrepeaters trunk lines of up to 100 miles long.

It is particularly suitable as an impulse accepting relay when a minimum of signal distortion is imperative, and because of the excellent change-over action and absence of contact chatter the relay is unequalled for impulsing the selector magnets in teleprinter automatic switching systems.

The relay responds satisfactorily to frequencies up to 100 c/s, when the contact gap is adjusted to 0.004 in. nominal, without serious bias disturbance. It can be left connected to line whilst awaiting a clearing signal, there being little distortion of through signals since the total leak can be of the order of 10,000 ohms.

Dimensionally the relay is interchangeable with the "3000" type relay. Terminations can either be made by means of a 12-pin plug base as illustrated, or with soldering tags in place of the pins. Protection is given by a magnetic screen and a transparent cap which is removable for contact adjustments.

Complete details supplied on request.

Manufactured by the Sole Licensees:—

TELEPHONE MANUFACTURING COMPANY LIMITED

Contractors to Governments of the British Commonwealth and other Nations

HOLLINGSWORTH WORKS · DULWICH · LONDON S.E.21 TEL: GIPSY HILL 2211 (10 LINES)

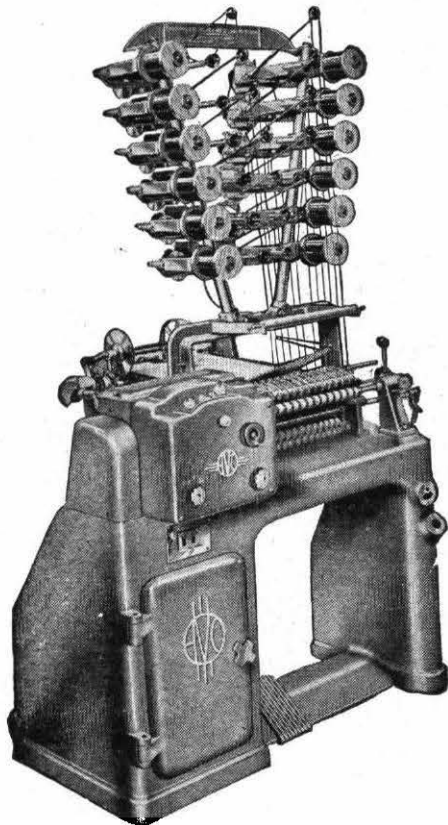

DOUGLAS AND MACADIE

Automatic COIL WINDERS

The large illustration depicts the improved "Douglas" Fully Automatic Multi-Winder, specially developed for the high-speed production of large quantities of coils with or without paper interleaving. It will produce round, square

or rectangular coils up to 6 in. each in length and up to 4½ in. diameter. As many as 12 smaller coils can be wound simultaneously within the total available winding length of 15 in. at headstock speeds of between 600 and 2,000 r.p.m.

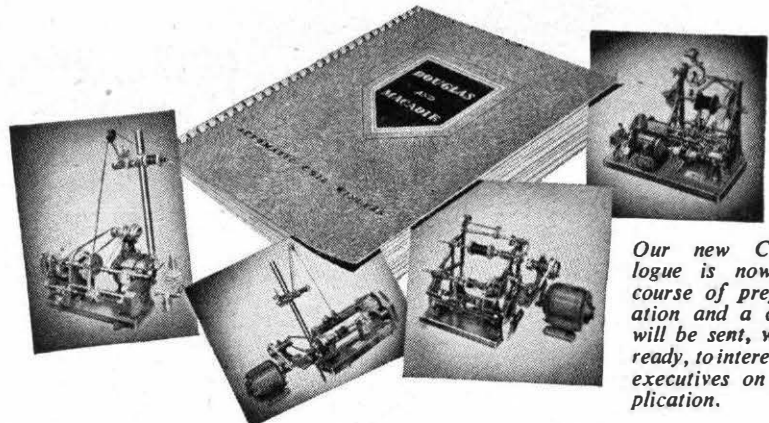

Our new Catalogue is now in course of preparation and a copy will be sent, when ready, to interested executives on application.

Sole Proprietors and Manufacturers:

THE AUTOMATIC COIL WINDER & ELECTRICAL EQUIPMENT CO. LTD.
WINDER HOUSE · DOUGLAS STREET · LONDON · S.W.1 Telephone: VICTORIA 3404/9

G.N.T.

MORSE TRANSMITTERS

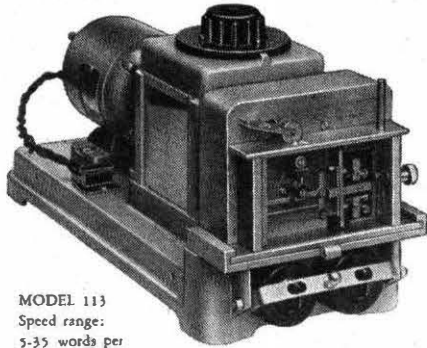

MODEL 113
Speed range:
5-35 words per
minute.
Specially suitable
for radio
training schools.

Absolutely constant speed
at all settings not withstanding
large voltage variations.

Noted for easy maintenance
and quick adjustment.

Supplied with A.C. or D.C.
motors as required.

Universally adopted

✧ Write for comprehensive catalogue.

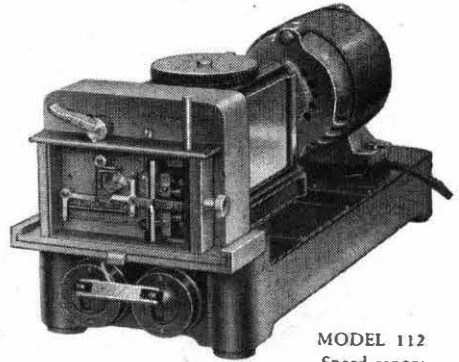

MODEL 112
Speed range:
13-250 words
per minute
without gear
changes.

THE GREAT NORTHERN TELEGRAPH COMPANY'S FACTORY

4, SYDHAVNS PLADS
COPENHAGEN SV . DENMARK



LONDON OFFICE: 5, ST. HELENS PLACE
LONDON E.C.3.

**POWER LIGHTING
TELEPHONY**

**HACKBRIDGE
CABLES**

**HACKBRIDGE
Cable Company Limited**

GPO

KELVIN WORKS, HACKBRIDGE, SURREY
In Association with BRYCE ELECTRIC CONSTRUCTION CO. LTD.
Branches at BIRMINGHAM, BRISTOL, CARDIFF, MANCHESTER, NEWCASTLE, SHEFFIELD

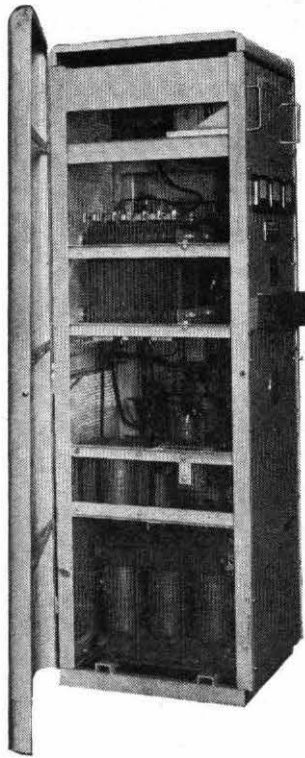

THE TRANSBOOSTER

The Transbooster is an improved method of voltage control, the equipments being produced in either static or mobile housings to suit varying requirements. A range of outputs is available and the illustration here shows a 3 kW model giving an output of 60 amperes at 50 volts nominal, smoothed for telephone exchange use. It is designed to hold D.C. output voltage within limits of $\pm 1\%$ from 1/20th up to full load and is independent of mains voltage variations of -10% to $+6\%$ and frequency variations from 41 to 52 c/s. The applications of this equipment are extensive, and full details of

WESTINGHOUSE
WESTALITE

CONSTANT POTENTIAL RECTIFIERS

can be obtained on request to. . .

Dept. P.O.E.E.J. 7

WESTINGHOUSE BRAKE & SIGNAL CO. LTD, 82 YORK WAY, KING'S CROSS, LONDON, N.1

SULLIVAN & GRIFFITHS
DIRECT READING
VARIABLE CONDENSERS

WITH NOVEL AIR CAPACITANCE
DECADE RANGE EXTENSION

This air dielectric condenser comprises a decade of air capacitance and a continuously variable air condenser thus giving a scale accuracy ten times that of an ordinary variable condenser of the same range.

Thus a decade of capacitance is provided—permanent in value and entirely free from loss, the only loss present in the complete combination of decade and variable condenser being that due to the solid insulating material which is ordinarily employed in the construction of the latter.

The variable condenser has a range of $100\mu\text{F}$ which is extended to $1100\mu\text{F}$ by ten increments of $100\mu\text{F}$, all adjusted with accuracy so that the decade is absolutely direct reading in μF , no corrections or calibration being necessary.



LIST No. C880

Electrical Standards for Research and Industry

Testing and Measuring Apparatus
for Communication Engineering

H. W. SULLIVAN, LTD., LONDON, S.E. 15.

POWER *behind the lines*

TUNGSTONE PLANTÉ CELLS are being regularly supplied to the British Post Office and Post and Telegraph Departments in many countries overseas. They conform fully to G.P.O. Standard specifications.

OPEN TYPE CELLS

Similar to the illustration here, these are available in glass and/or lead lined wooden boxes in capacities from 100 a.h. to 5000 a.h.

REPLATALS

We are in a position to supply plates for the replating of existing Planté Batteries.

ENCLOSED TYPE CELLS

As illustrated below, these are in moulded glass boxes with sealed-in lid. Capacity range from 10 a.h. to 200 a.h.

PORTABLE TYPE BATTERIES

A range of portable type Batteries is in regular production, made to G.P.O. specifications, for ancillary duties.

Overseas customers are invited to cable or write their enquiries for batteries or parts. Visitors to London are welcome at our offices. (Just off Fleet Street.)

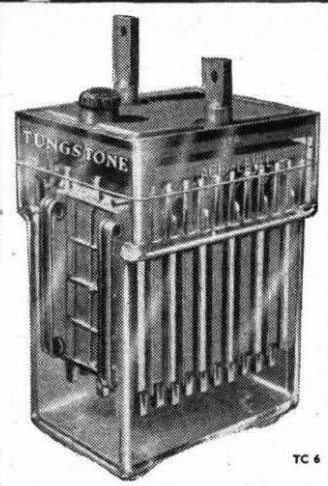
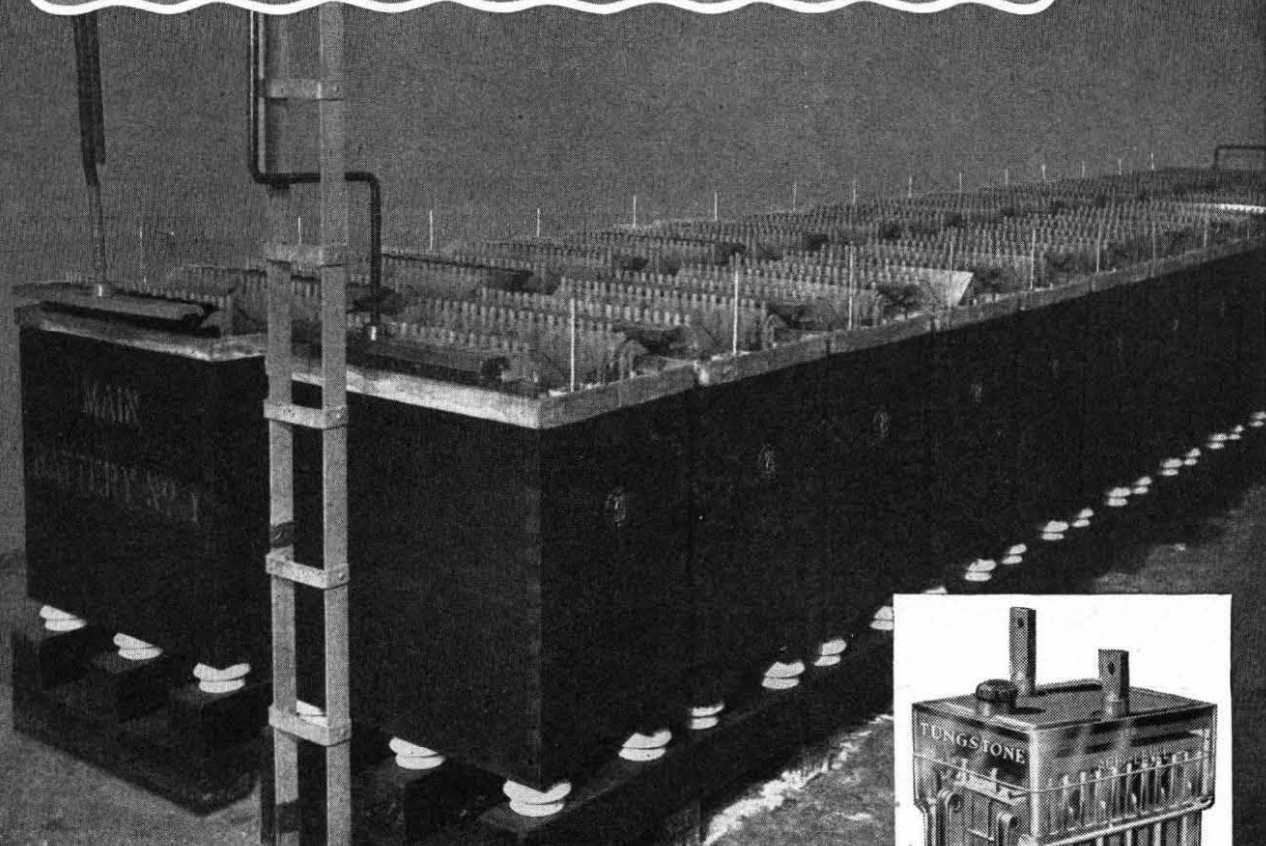

TC 6

TUNGSTONE *Batteries*

For further particulars write : TUNGSTONE PRODUCTS LIMITED,
10 SALISBURY SQUARE, LONDON, E.C.4, ENGLAND. Cables: "Dilutum" London.

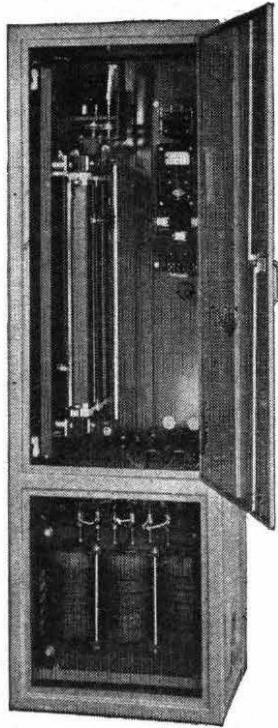

30 KVA three phase cubicle type automatic regulator.

BR/BP5091/BKH

BERCO/B.P.T. Voltage Control Equipment

BERCO/B.P.T. voltage regulating and stabilising equipment is designed to afford a constant supply voltage to industrial scientific and electro-medical apparatus — and to all other electrical equipment which is normally sensitive to voltage fluctuation. Standardised sizes and ratings in single, three phase, hand operated and motor driven models meet most requirements but special designs can be made where necessary.

Applications apply to induction heating equipment, electric furnace control, radio and scientific equipment, process control, chemical analysis, X-ray and electro-medical apparatus, meter testing equipment, and wherever a process depends on a constant supply voltage.

Complete details and specifications obtainable without obligation. Please write for booklet 5091.

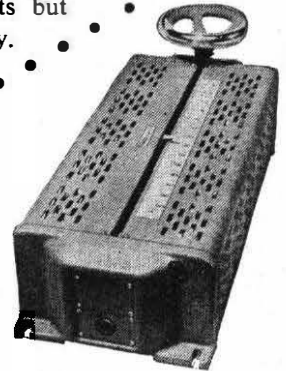

Hand operated BERCO "Regavolt" (single phase).

**THE BRITISH ELECTRIC RESISTANCE CO. LTD.
BRITISH POWER TRANSFORMER CO. LTD.**

Queensway · Ponders End · Middlesex

Telephone: HOWard 1492

Telegrams: "VitrohM, Enfield"

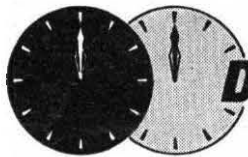

DESIGNED FOR 24 HOURS PER DAY OPERATION

BATTERY DRIVEN CARRIER CURRENT GENERATORS FOR VOICE FREQUENCY TELEGRAPH TRANSMISSION

These generators are the result of many years experience in this field. They are made in three forms for 18, 24 or 27 channel transmission systems. Frequency ranges 420 to 2460 c.p.s., 420 to 3180 or 300 to 3420 c.p.s. in 120 c.p.s. steps. Speed and frequency accuracy $\pm 12\%$ for long periods without maintenance. Input 20 to 28 volt d.c. or 150 to 184 volts d.c.

Comprehensive details from the Manufacturers . . .

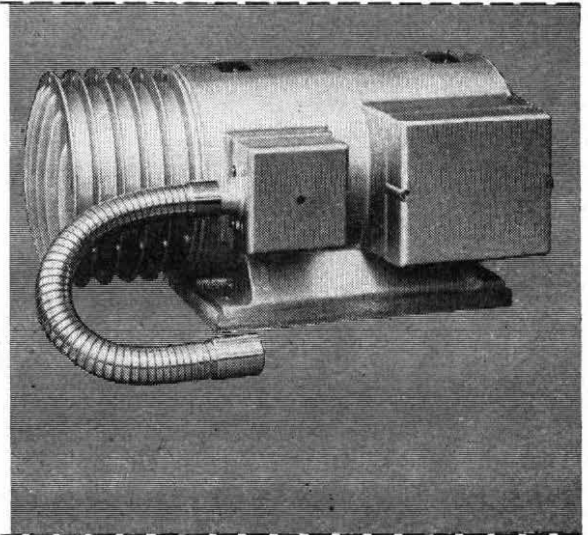

WALTER JONES & Company (Engineers) Limited

**NEWLANDS PARK · SYDENHAM
LONDON · S.E.26 · SYDenham 6264**

**ELECTRICAL MEASURING
INSTRUMENTS
OF THE HIGHER GRADES**

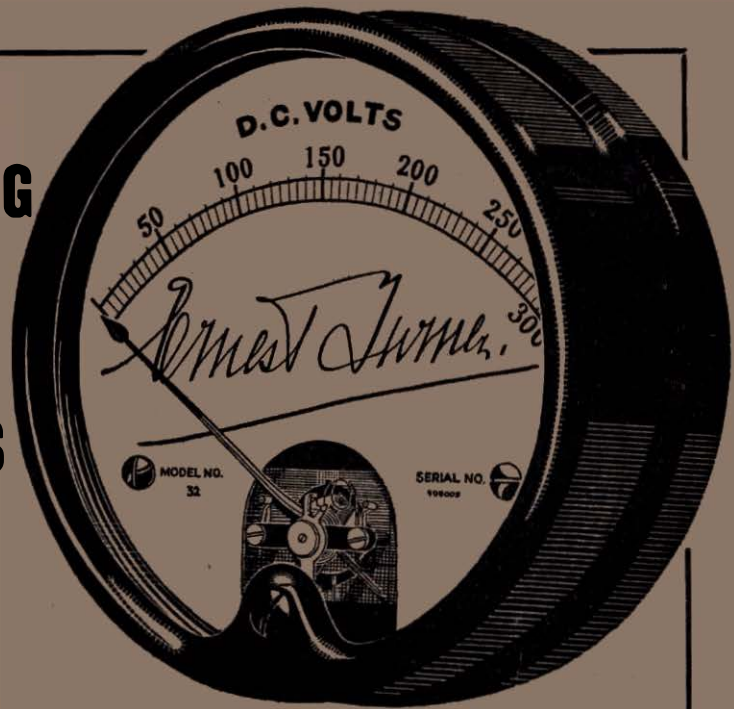

ERNEST TURNER ELECTRICAL INSTRUMENTS LTD.
 CHILTERN WORKS, TOTTERIDGE AVENUE, HIGH WYCOMBE, BUCKS.
 Telephone : High Wycombe 1301/2
 Telegrams : Gorgeous, High Wycombe



**VALVE
VOLTMETER
TYPE 712**



THE balanced circuits used in this Valve Voltmeter enable a degree of stability hitherto unknown in this type of instrument to be obtained, and ensure that the meter zero remains constant over considerable periods of time, and under conditions of widely fluctuating mains voltage.

- Frequency range from 30 c/s to 200 Mc/s
- Measures both positive and negative D.C. voltage
- Balanced, unbalanced and differential inputs
- Six resistance ranges up to 100 megohms
- Very low probe input capacity
- Balanced circuitry ensures exceptional stability
- Immediate delivery



Full details of this or any other Airmec Instrument will be forwarded gladly upon request

AIRMEC
L I M I T E D

HIGH WYCOMBE

BUCKINGHAMSHIRE

ENGLAND

Tel: High Wycombe 2060

Cables: Airmec High Wycombe

TELEPHONE DISTRIBUTION

EQUIPMENT

ENGINEERS WHO ARE INTERESTED
IN TELEPHONE DISTRIBUTION EQUIP-
MENT ARE INVITED TO REQUEST
SECTION T.C.13 OF OUR TELECOM-
MUNICATION CABLES CATALOGUE.

TELEPHONE:
SOUTHAMPTON
2141 (5 lines).

IRELLI & GENERAL
CABLE WORKS, Ltd., SOUTHAMPTON

TELEGRAMS
"PIGEKA YBEL
SOUTHAMPTON"

EDISWAN

Telephone Line Protectors



Surge currents induced on telephone lines by electric storms or breakdowns on neighbouring power lines may be effectively controlled by Ediswan telephone line protectors.

These special electrode gas discharge tubes have been developed in collaboration with G.P.O. Engineers to provide economical and effective protection for telephone systems without impairing the service.

Full details of these protectors and their application is given in the Ediswan publication C.1581 which is available on application.

THE EDISON SWAN ELECTRIC CO., LTD.

155 CHARING CROSS ROAD, LONDON, W.C.2

Member of the A.E.I. Group of Companies

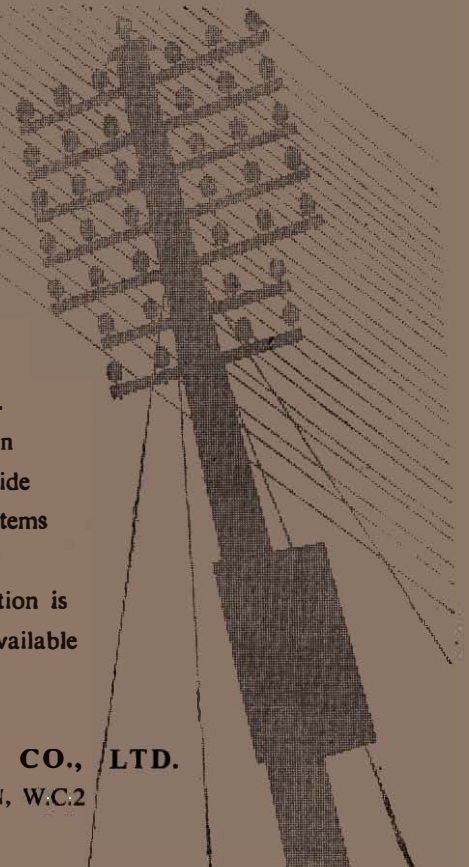

TE197