

THE POST OFFICE ELECTRICAL ENGINEERS' JOURNAL

Vol. 45

JANUARY 1953

Part 4

CONTENTS

	PAGE
A VISIT BY HIS ROYAL HIGHNESS THE DUKE OF EDINBURGH TO THE POST OFFICE RESEARCH STATION, DOLLIS HILL	143
AN EXPERIMENTAL PROBE MICROPHONE FOR THE MEASUREMENT OF SOUND PRESSURES—R. B. Archbold, B.Sc.(Eng.)	145
AN AUTOMATIC-SCANNING RECEIVER FOR RADIO MONITORING—F. J. M. Laver, B.Sc., A.M.I.E.E., F. M. Billingham, B.Sc.(Eng.), A.M.I.E.E. and F. J. Lee	149
SINGLE-SIDEBAND MULTI-CHANNEL OPERATION OF SHORT-WAVE POINT-TO-POINT RADIO-LINKS. Part 2—An Independent-Sideband Transmitter Drive Unit and Monitor Receiver—F. C. Owen and A. B. Ewen	154
C.C.I.F. FIELD TRIALS OF INTERNATIONAL SEMI-AUTOMATIC TELEPHONE OPERATION. Part 2—Facilities to be Provided—J. V. Miles	160
TEST EQUIPMENT FOR THE LONDON CENTRE OF THE C.C.I.F. FIELD TRIALS OF INTERNATIONAL SEMI-AUTOMATIC TELEPHONE OPERATION—A. W. Bates	165
A COMBINING UNIT FOR SUPERIMPOSING TWO TELEVISION PICTURES ON THE SAME CATHODE RAY TUBE—D. Wray, B.Sc.(Eng.), A.M.I.E.E.	172
A 30-cwt. TRANSPORTABLE GANTRY	174
A TELEPHONE TRANSMISSION REFERENCE CIRCUIT USING ADJUSTABLE INTERRUPTION DISTORTION—D. L. Richards and J. N. Shearme	175
NOTES AND COMMENTS	180
INSTITUTION OF POST OFFICE ELECTRICAL ENGINEERS	180
REGIONAL NOTES	181
ASSOCIATE SECTION NOTES	186
STAFF CHANGES	188
INDEX TO VOL. 45	189
BOOK REVIEWS	148, 159, 171, 177, 178, 179

Price 2/6 net

THE INSTITUTION OF POST OFFICE ELECTRICAL ENGINEERS

How to make certain of your City & Guilds Certificates



"I guarantee tuition until you have passed"

If you consider taking one or the whole series of C. and G. examinations then I can help you. BY POST, in your own time, one of my Telecommunications specialists will coach you until you pass. He will give you individual attention, he will study you and your problems. And you will be surprised how fast you progress. For The Bennett College has specialised in technical subjects since it was founded 50 years ago. My system of personal postal tuition has helped thousands of students through their exams. It can do the same for you.

Send me the coupon to-day. I will send you—without obligation—full information on your subject.

Rep Bennett
GOVERNOR

YOU CAN START ON A BENNETT COURSE FOR ONLY **30/-**

TEAR OUT

with monthly instalments of 15/-

WHICH IS YOUR NEXT STEP?

- Preliminary Course
- Telecommunications Principles I—V
- Telecommunications Practice
- Telephone Exchange Systems I—III
- Radio I—IV
- Telegraphy I & II
- Line Transmission I & II
- Mathematics for Telecommunications I—V
- Radio Servicing Certificate
- Television Servicing Certificate
- A.M.I. Mech.E.
- and many other subjects

The BENNETT COLLEGE

To the Governor, Dept. A24, The Bennett College, Sheffield, England. I would like to have (at no cost) your prospectus on:

NAME

ADDRESS

AGE (if under 21)

PLEASE WRITE IN BLOCK LETTERS

MADE BY PEOPLE WITH A CONSCIENCE

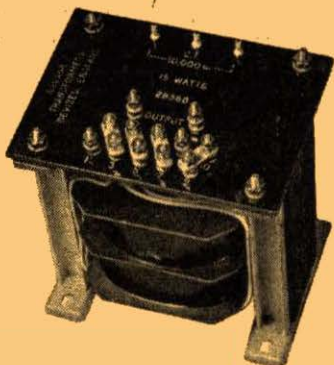

It is the Savage Tradition that only the best is good enough and all employees are individually trained to take a pride in their work. Every instrument which leaves our works is the product of our conscientious best.



Savage Transformers Ltd., Numteed Road, Devizes, Wilts. Telephone: Devizes 536

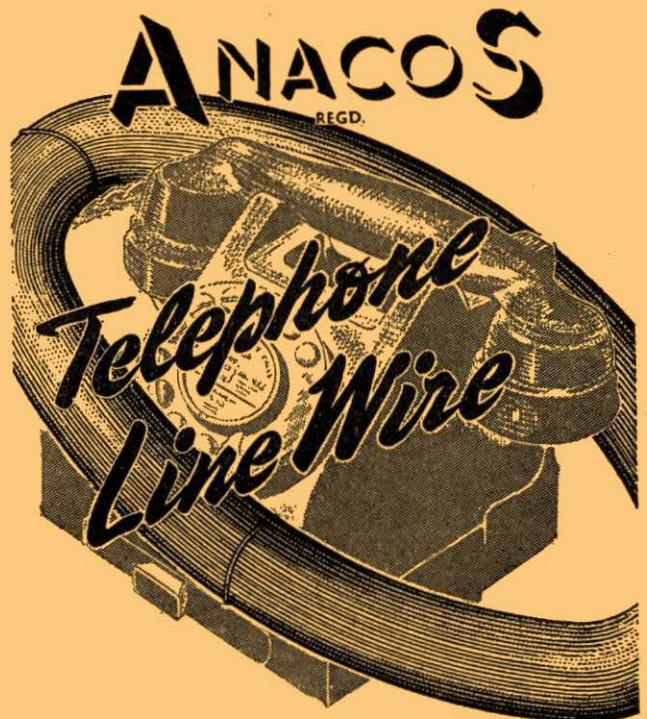

FOR THE RIGHT CONNECTION

FREDERICK SMITH & COMPANY

ANACONDA WORKS, SALFORD, 3, LANCS.

Incorporated in The London Electric Wire Company and Smiths Limited Associated with The Liverpool Electric Cable Co. Ltd. and Vactite Wire Co. Ltd.

FREE THIS VALUABLE BOOK



which details the wide range of Engineering and Commercial courses of modern training offered by E.M.I. Institutes—the only Postal College which is part of a world-wide Industrial Organisation.

Courses include training for:

P.M.G. Certificates, City and Guilds Grouped Certificates in Telecommunications; A.M.Brit.I.R.E. Examination, Radio Amateur's Licence, Radio & Television Servicing Certificates, General Radio and Television Courses, Radar, Sound Recording, etc. Also Courses in all other branches of Engineering.

E.M.I.

Institutes

associated with
MARCONIPHONE

COLUMBIA

H.M.V.

(His Master's Voice)

ETC.

COURSES FROM

£1

PER MONTH

POST NOW

Please send, without obligation, the above FREE book. E.M.I. Institutes, Dept. 22, 43 Grove Park Road, London, W.4.

Subject(s) which interest me

Name

Address

IC 10c

THE POST OFFICE ELECTRICAL ENGINEERS' JOURNAL

Vol. 45

January 1953

Part 4

A Visit by His Royal Highness the Duke of Edinburgh to the Post Office Research Station Dollis Hill

ON 28th October, 1952, the Post Office was honoured by a visit by His Royal Highness the Duke of Edinburgh to its Research Station. The visit lasted from 10.30 a.m. to 4.15 p.m. Accompanying the Duke on the tour of the station were the Postmaster-General, the Engineer-in-Chief, the Deputy Engineer-in-Chief, the Controller of Research and the Duke's equerry, Lieutenant-Commander M. Parker.

The principal items of equipment or investigation which were demonstrated or discussed were:—

A battery-operated radio-telephone set for extending the telephone service to isolated communities, such as those on islands off the west coast of Scotland and in remote hamlets.

The London terminal equipment of the experimental centimetric-wave radio-relay system which transmits television programmes to the B.B.C. transmitter at Wenvoe in South Wales.

The fading machine which simulates, in the laboratory, the complex transmission characteristics of short-wave radio circuits.

A technique for studying the characteristics of short-wave aerials by using centimetric-wave models about $\frac{1}{15}$ the size of full-size aerials.

A modern type of single-sideband short-wave radio-receiver, capable of receiving four independent telephone channels.

A radio-receiver for recording automatically the extent to which all parts of the short-wave spectrum are occupied by signals.

A spectrum-analyser for examining in detail the spectra radiated by short-wave transmitters.

The transmission of television signals over about a mile of audio-frequency cable and methods of equalising for quickly obtaining best results.

Techniques used for producing quartz elements for very accurate frequency control and some examples of apparatus incorporating this form of control.



THE DUKE ENTERING THE MAIN BUILDING OF THE RESEARCH STATION. HE IS ACCOMPANIED BY [R. TO L.] BRIGADIER L. H. HARRIS, CONTROLLER OF RESEARCH; DR. W. G. RADLEY, ENGINEER-IN-CHIEF; EARL DE LA WARR, POSTMASTER-GENERAL, AND MR. H. FAULKNER, DEPUTY ENGINEER-IN-CHIEF.

The design of submarine repeaters now used in shallow waters to provide 60 circuits over 0.62 in. diameter cable with a repeater spacing of 16 to 18 nautical miles; also an experimental model of a repeater for depths down to 3,000 fathoms.

The non-reverberant room which effects nearly complete absorption of sound at its surfaces, and models of Medresco hearing aids which were being tested in this room.

Investigations being made of factors affecting the life of high-vacuum receiving valves and progress which has been made towards ensuring long life of such valves.

The growing of water-soluble piezo-electric crystals by controlled cooling of saturated solutions.

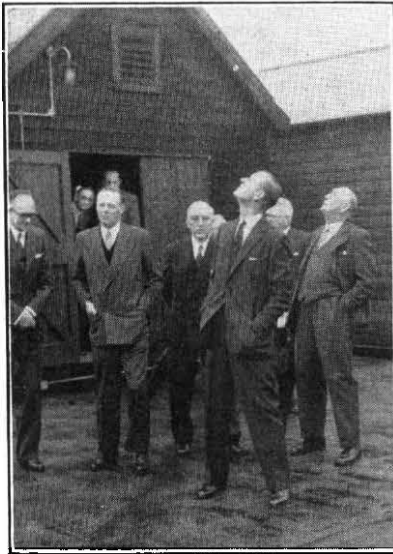

INSPECTING AERIAL SYSTEM OUTSIDE HUT ON TOP OF SOUTH BLOCK.



THE DUKE EXAMINES APPARATUS USED FOR MEASURING TRANSISTOR ACTION.



INSPECTING A TRAVELLING WAVE TUBE IN HUT ON TOP OF SOUTH BLOCK.

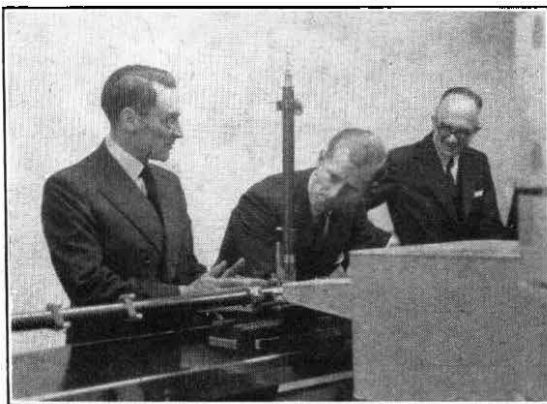

EXAMINING THE RAYLEIGH DISK TUBE.



RETURNING FROM NEW WORKSHOP BUILDING.

A model electronic digital computer, showing the principles of operation of a large high-speed computer which has been designed at Dollis Hill and is now being installed for the Ministry of Supply.

Studies of the physical properties of germanium necessary for transistor action, and a circuit application of a crystal triode.

Investigation of the practicability and merits of electronic switching for telephone exchanges and demonstration of an elementary form of purely electronic exchange.

The methods in use for measuring sound pressures by Rayleigh disk and recent developments of probe microphones.

Doors of all laboratories were left open and the Duke displayed interest also in work being done other than these selected items.

Starting from the controller's room in the main research building, the visitors proceeded to the receiving building of the Radio Experimental Branch, thence to the roof of the

south block (where is sited the hut which houses the terminal equipment of the television radio-relay system), then through the radio workshop to the radio building. From here the party went to the submarine repeater building (late training school block), to the paddock block, to the basement of the new workshop building (where some laboratories are in use, though the building has not yet been completed), and so to the "Green Room" of the canteen for lunch. After lunch the main research building and the research workshop were visited.

The Duke conversed with several of the men at their machines in both workshops, and also with local representatives of the different Staff Associations (eight in all) who were presented to him in the Lecture Theatre. Here, also, tea was served and a film was shown illustrating some of the work of the photographic group.

The visit was not only an honour, it was also a very real pleasure. It has left a lasting memory of the manifest interest which our visitor showed in every person he met and in all the work that he saw.

An Experimental Probe Microphone for the Measurement of Sound Pressures

R. B. ARCHBOLD, B.Sc.(Eng.)†

U.D.C. 534.612: 621.395.61

For many tests associated with telephone transmitters and receivers it is essential to know the sound pressure existing at a specified point. In this article the characteristics required by a microphone to make it suitable for such sound pressure measurements are given, together with a description of the development of a probe microphone to meet these requirements. Some examples are included of the applications of a probe microphone to the testing of telephone transmitters and receivers, and a brief reference is made to the extent to which certain features of the design may be applied to other microphones.

Introduction.

THE performance of electro-acoustic transducers, e.g. telephone transmitters and receivers, can only be measured objectively if the sound pressures which operate them, or which they produce within their useful frequency range, can be measured. A calibrated high-quality (stable and linear) microphone can be used for measuring sound pressures, but it fails to do so if it is so large that its presence distorts the sound field and the effect of the distortion cannot be allowed for. More obviously it fails if it is too big to insert at the point where the measurement is to be made (e.g. in the space between the ear and the diaphragm of a telephone receiver held to the ear). The wavelength of sound in air is only about 2.7 in. at 5,000 c/s, and is inversely proportional to the frequency; in order that a microphone, or other obstacle, shall not distort a sound field, its dimensions must be small relative to the wavelength.

For these reasons it is common practice, for acoustical measurements, to couple to the diaphragm of a high-quality microphone a tube, the open end of which admits the sound pressures to actuate the diaphragm. The open end, where the sound pressure is measured, can be very small and the length of the tube removes the bulk of the microphone sufficiently far from the point of measurement. Such a device constitutes a probe microphone. It is simple to construct and use if it is only needed for exploring a sound field at a single frequency by measuring the relative sound pressures at different points, and it has frequently been put to this use. If, however, it is required for measuring the performance of electro-acoustic transducers over a wide range of frequencies, the design of a suitable probe microphone becomes much more difficult because reasonable uniformity of the sensitivity at all frequencies within the range is necessary at as high a level of sensitivity as can be obtained. It is with this latter class of requirement that the present article is concerned.

There are two inherent disadvantages in using a probe tube which have to be overcome as far as possible. One is the loss of sensitivity due to the reduction of the force available for vibrating the diaphragm in the ratio of the area of the internal cross-section at the open end of the tube to the effective area of the diaphragm, approximately. The other is the formation of standing waves in the tube which create conditions for a succession of resonances and anti-resonances, the effects of which need to be smoothed out without too much further loss of sensitivity.

In what follows, mention is made, by way of illustration, of some applications of a probe microphone to acceptance testing of telephone transmitters and receivers. Then the development of a type of probe microphone suitable for these, and indeed many other, applications is traced from an experimental model through various stages of design of the coupler.

Basic Principles.

Probe microphones are well known in the field of acoustical measurements and have been described previously.^{1,2} They may take a variety of forms, but essentially they consist of

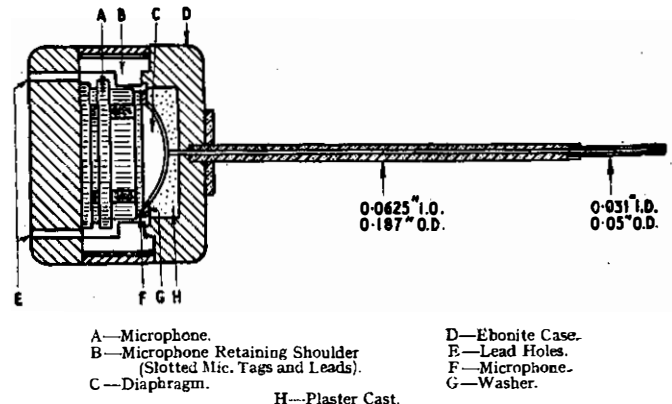

FIG. 1.—CROSS-SECTION OF EARLY LABORATORY MODEL OF PROBE MICROPHONE.

a microphone element, e.g. moving coil, condenser or crystal unit, the diaphragm of which is not used directly in the sound field, but is coupled to it by means of a pipe or tube. Fig. 1 shows, for example, the cross-section of a probe microphone with a moving-coil element, an early laboratory model on which the design to be discussed was based. To the acoustical engineer the probe microphone is virtually a sound pressure gauge and is often used for sound pressure measurements. Its sensitivity (S) is usually expressed in millivolts/dyne/sq. cm. and given as a function of frequency, so that, if the e.m.f. (E mV) generated by the microphone when it is placed in a pure tone sound field is measured, the sound pressure (P) in dynes/sq. cm. (r.m.s. value) may be simply calculated, i.e. $P = E/S$.

The fact that the probe microphone is used to measure sound pressures at a point places two main limitations on its design:—

- (1) It must not seriously disturb the sound field into which it is placed, by virtue of its size, i.e. the obstacle effect, already mentioned, must be negligible.
- (2) It must have a high acoustical impedance compared with the acoustical circuit across which it is to measure.

The reason for the second consideration is evident from an electrical analogy in which the sound pressure measurement may be likened to an electrical voltage measurement. The voltmeter has to be of relatively high electrical impedance to avoid shunting effects and similarly the probe microphone has to be of high acoustical impedance to avoid shunting the acoustical circuit. Both limitations can, perhaps, best be demonstrated by considering the simple principles used in certain of the production or pre-installation tests of telephones.

Application to Acceptance Tests.

Fig. 2 (a) shows the principle underlying one form of test used for carbon transmitters. A pure tone of variable frequency is fed to a small loudspeaker (or artificial voice), the

† Executive Engineer, Post Office Research Station.

¹ "A Device for Measuring Sound Pressures in Free Air," W. West, P.O.E.E.J. Vol. 26, p. 260.

² "Acoustic Measurements," Leo L. Beranek, pp. 732-735.

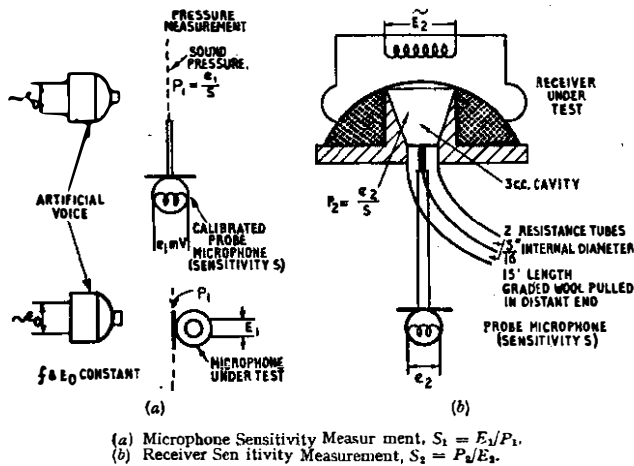

FIG. 2.—SIMPLE USES OF PROBE MICROPHONE.

supply voltage being electrically controlled so that the sound pressure (P_1) across some specified plane in front of the loudspeaker is approximately constant over the required frequency range. The magnitude of the voltage required to drive the loudspeaker to give this constant pressure is initially determined by measuring the sound pressure with a probe microphone, using the relationship expressed in the previous section. The transmitter under test is placed with its diaphragm, or some other datum, in the specified plane and the open circuit e.m.f. generated (say E_1) is then measured as a function of frequency. Then at any frequency the sensitivity of the transmitter may be expressed as $S_1 = E_1/P_1$, where P_1 is the constant sound pressure.

Owing to the diffraction of the sound field by an obstacle, a change of sound pressure will take place if a large microphone is used for the pressure measurement,³ and it is for this reason that the first limitation of size is imposed on the probe microphone design.

To show the reason for the second limitation, a method of testing telephone receivers may be considered. Fig. 2 (b) illustrates the test. The receiver is loaded with an artificial ear⁴ which is simply a combination of acoustical elements designed to present to the receiver an acoustical impedance similar to that of the real ear over a specified audio frequency range.⁵ It consists of a cavity of approximately 3 cc volume with two tubes of $\frac{3}{16}$ in. internal diameter leading from it. The tubes have wool pulled into the ends remote from the cavity and graded in length so that sounds produced in the cavity are not reflected from the distant ends. The tip of a probe microphone is inserted into the base of the cavity. A measured sinusoidal voltage (E_2) is supplied to the telephone receiver and the corresponding sound pressure (P_2) which is set up in the cavity is measured with the probe microphone. Then the sensitivity of the receiver will be, $S_2 = P_2/E_2$ dynes/sq. cm./volt, which again is measured at several frequencies.

Without entering into any precise definition of acoustical impedance, the approximate calculated magnitudes of the impedances involved may now be considered, again using an electrical analogy. The 3-cc cavity corresponds to a capacitive reactance of the order of 80 acoustical ohms at 1,000 c/s, i.e. about 800 acoustical ohms at 100 c/s. The two tubes in parallel with the cavity broadly correspond to a pure resistance of about 120 acoustical ohms. The magnitude of the impedance of the parallel combination at 100 c/s is about 120 acoustical ohms, so that the impedance looking

into the probe microphone must be high compared with this value for satisfactory pressure measurements down to 100 c/s. A probe of even $\frac{1}{16}$ in. internal diameter may offer only 2,000 acoustical ohms impedance, so that for negligible shunting loss the internal diameter should be less than this.

Description of Experimental Microphone.

The experimental probe microphone design is influenced by a variety of considerations, including those of size already discussed, but is broadly based on that of the laboratory model of Fig. 1. The microphone element is a moving-coil unit which was chosen because, although such units are of delicate construction, it is found in practice that they are relatively robust and able to withstand a fair amount of mechanical shock. To avoid magnetic effects between the moving coil unit and other transducers, e.g. the receiver under test on an artificial ear, the unit is fitted in a heavy mild steel case and a probe about 5 in. long is used. The heavy case also safeguards the unit from unwanted signals which might be transmitted via a light case. The probe is of stainless steel and has an internal diameter of about 0.030 in. (external diameter 0.050 in.); it is likely, therefore, that it will have a characteristic impedance greater than 10,000 acoustical ohms and the obstacle effect will be negligible in the working frequency range. A rigid brass protective cover is provided to safeguard the probe.

The brass coupler which forms the termination between the probe and the microphone unit is the most interesting part of the construction, because the size and shape of the cavity which it forms above the microphone diaphragm are the only variables which may be controlled if a standard microphone and constant bore tube are accepted. The variation of these parameters and their effect on the sensitivity of the microphone were the subject of the development experiments. Tests with the laboratory probe had indicated that a clearance of about 0.020 in. between the microphone diaphragm and the cover might prove to give the most satisfactory sensitivity/frequency characteristic. With this in mind the shape of the coupler was made as in Fig. 3 (a), so that the radius of the coupler profile was

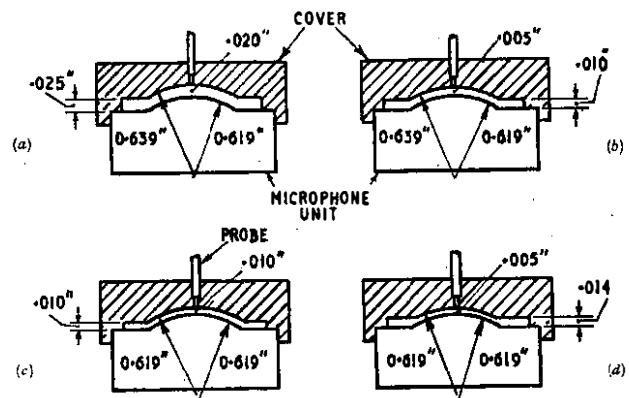

FIG. 3.—CAVITY SHAPES (NOT TO SCALE).

0.020 in. greater than that of the microphone diaphragm. The outer rim or "washer" portion was, however, initially made 0.030 in. deep so that it could be turned down as required and the effect of variation of depth could be investigated.

Design Objectives.

Fig. 4 shows the sensitivity/frequency characteristic of the laboratory probe microphone, illustrated in Fig. 1. For the unequalled condition of the microphone the characteristic with its succession of peaks and troughs (due to standing waves in the tube) resembles that of the voltage/

³ "Acoustical Engineering," W. West.

⁴ Post Office Research Report No. 12,357. "The Design of an Artificial Ear and Probe Microphone for Factory Testing."

⁵ "Measurements of the Acoustical Impedances of Human Ears." W. West, P.O.E.E.J., Vol. 21, p. 293.

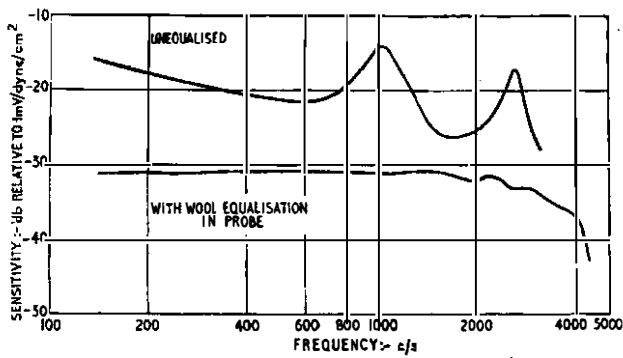

FIG. 4.—SENSITIVITY OF LABORATORY PROBE MICROPHONE WITH INPUT TRANSFORMER.

frequency characteristic at the distant end of an incorrectly terminated transmission line. When a small amount of lambs' wool is introduced into each end of the tube, the characteristic is smoothed as shown, but is seen to cut-off rapidly at about 4,000 c/s. For many purposes this frequency range was not sufficiently wide and it was thought that the objective should be to attempt to produce a microphone with a smooth sensitivity/frequency characteristic up to at least 8,000 c/s and to maintain the sensitivity in the range 80-8,000 c/s, so that it was not allowed to fall more than 6 db. below the mean sensitivity in the range 80-1,000 c/s.

Experimental Work.

The tests made during the development of the probe microphone were in three stages and consisted of measurements of the sensitivity/frequency characteristic of the probe microphone made after the variation of one or more coupler dimensions. The method of making these calibrations using a Rayleigh Disk and standing wave tube³ is not discussed here and only a few of the many characteristics taken are recorded to show the general trend of results. Additional acoustic damping, such as by lambs' wool, was not introduced into the probe tube in any of the examples illustrated, other than the one curve in Fig. 4.

Stage I. Fig. 5 shows the variation of microphone

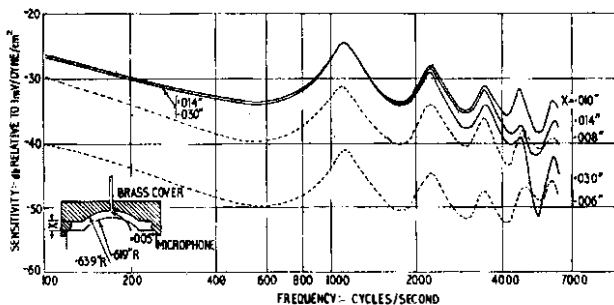

FIG. 5.—SENSITIVITY/FREQUENCY CHARACTERISTICS FOR VARYING EDGE CLEARANCE, WITH 0.639 IN. COVER RADIUS AND 0.031 IN. I.D. TUBE.

sensitivity with edge clearance between the diaphragm and the 0.639 in. radius cover. As the clearance is reduced from 0.030 in. to 0.010 in., the sensitivity increases at the higher frequencies, particularly in the 5,000 c/s region. For clearances less than 0.010 in., the sensitivity is seriously reduced by an almost constant amount at all frequencies. The cavity shape with the edge clearance of 0.010 in. was as shown in Fig. 3 (b). It will be noticed that the diaphragm clearance for optimum sensitivity was less than the expected value of 0.020 in. The axial clearance, i.e. the clearance above the centre of the diaphragm, was 0.005 in. and the cavity was of a divergent meniscus form. It was thought that a higher

sensitivity would be obtained if the axial clearance was greater than or equal to the edge clearance. With this in mind a coupler was made with a radius equal to that of the microphone diaphragm (0.619 in.) for stage II tests.

Stage II. The optimum clearance for the new coupler was found by applying the information gained from the previous test that the low-frequency sensitivity remained constant until the optimum was reached. Measurements at a few low frequencies were made to resolve this value, which again was found to be 0.010 in. (Fig. 3 (c)). The change of coupler shape, however, gave an improved sensitivity of about 2 to 3 db. at frequencies above 3,000 c/s when compared directly with the previous coupler.

Stage III. Although the 0.619 in. radius coupler had improved the sensitivity at the higher frequencies, it seemed significant that the optimum edge clearance was still 0.010 in. Examination showed that the height of the stiffening corrugations at the edge of the microphone diaphragm was limiting the clearance. As a result it was decided to make further tests with a coupler of 0.619 in. radius having a fixed safe working clearance of 0.014 in. at the edge. The axial clearance was varied as required by turning equal depths of metal off both the flat faces of the coupler so that the constant edge clearance was maintained. The effect of the variation on sensitivity is shown in Fig. 6. Previously, as

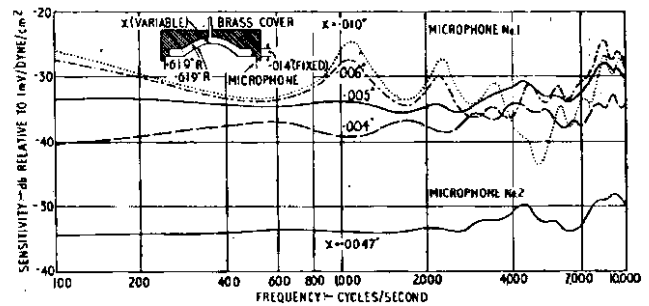

FIG. 6.—SENSITIVITY/FREQUENCY CHARACTERISTICS FOR VARYING AXIAL CLEARANCE, WITH 0.619 IN. COVER RADIUS AND 0.031 IN. I.D. TUBE.

the optimum clearance was approached, the resonance peaks in the low-frequency range were unaffected and for clearances less than the optimum the sensitivity was reduced by an almost constant amount. In this case, however, the marked resonances were smoothed even at low frequencies by the viscous damping effect of the small air clearance above the diaphragm. In addition, the output in the low-sensitivity region above 4,000 c/s is increased so that the sensitivity approaches a constant value to a much closer degree than before. It was also found possible to "over-equalise" the microphone, an effect which had been observed before when using lambs' wool damping, and obtain a form of inverse characteristic such as that shown for the 0.004 in. clearance. The curve using a 0.005 in. clearance, which was finally adopted, shows the microphone to have almost constant sensitivity up to about 3,000 c/s and a gradual rise in sensitivity above this frequency up to 10 kc/s where it starts to fall away. The cavity shape was as shown in Fig. 3 (d). The degree to which the sensitivity can be maintained constant in the low-frequency range is largely a question of the length of time that can be given to the tailoring of individual samples by finding the exact optimum spacing. For example, microphone No. 2 of Fig. 6 is more carefully equalised, but even in this case little time was spent to obtain a constant response.

The final performance of the small-bore probe microphone is better than was originally expected in the design objectives. For many purposes it might be considered that it was too tedious to apply the method of equalisation to the

same extent as in the case described. In this connection it is interesting to note that, at any stage in the equalisation process, large undulations in the sensitivity/frequency characteristic could be readily smoothed by the introduction of a small quantity of lambs' wool into each end of the probe. The resulting curve would, however, have a trough or region of low sensitivity at about 5,000 c/s.

Other Microphones.

Tests have shown that the technique of using a small quantity of lambs' wool, glass wool or similar sound-absorbing material at each end of the probe in order to smooth the response of a probe microphone, may be applied successfully to probes up to about $\frac{3}{16}$ in. diameter. Such microphones are, of course, much more sensitive than the small probe microphones already described because of the greater area over which sound pressures are applied and hence the greater force available for vibrating the diaphragm. For larger tubes a form of continuous "loading" has been found satisfactory, using strands of darning wool down the tube with a small additional quantity of wool at the ends. The characteristic of a moving-coil probe micro-

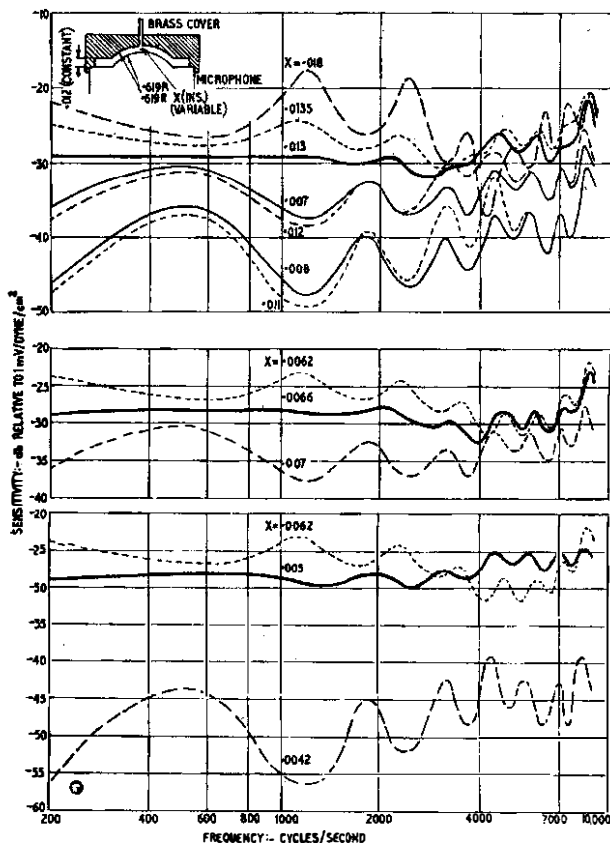

FIG. 7.—SENSITIVITY/FREQUENCY CHARACTERISTICS FOR VARYING AXIAL CLEARANCE, WITH 0.619 COVER RADIUS AND 0.05 IN. I.D. TUBE.

Book Review

"Mechanical Draughtsmanship." S. M. Hood, M.I.I.S., A.F.F., I.W.M. English Universities Press, Ltd., London. 183 pp. 203 ill. 6s.

This book is one of the "Teach Yourself" series, and for the student who wishes to learn machine drawing from a book this volume goes a long way towards making it possible. It is arranged in a series of eleven lessons with exercises set at the end of each. Drawing technique, from the care and use of instruments, projection, sections and geometrical construction

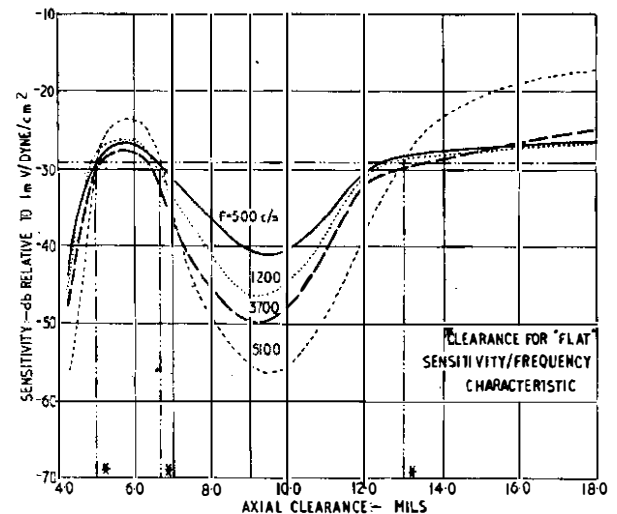

FIG. 8.—SENSITIVITY/CLEARANCE FOR DIFFERENT FREQUENCIES, WITH 0.619 COVER RADIUS AND 0.05 IN. I.D. TUBE.

phone with a $\frac{1}{4}$ -in. tube, for example, has been successfully smoothed in this manner. In the case of the larger-bore probe microphones the characteristic, although smoothed, falls away at the higher frequencies. A reduction of sensitivity of about 6 db. per octave is typical of observations made on both condenser and moving-coil microphones with probes between $\frac{1}{8}$ in. and $\frac{1}{4}$ in. diameter.

Possibly the most interesting results obtained in the investigation were those obtained with a moving-coil microphone with a probe of 0.05 in. diameter which was otherwise identical with the 0.03 in. probe microphone. With this microphone three values of clearance were found which gave a relatively flat sensitivity/frequency characteristic. Fig. 7 gives three families of curves corresponding to clearances in the region of the three "flat" values. At low frequencies up to about 3,000 c/s the curves follow a smooth pattern, but at higher frequencies there appears to be no logical sequence in their arrangement. If, however, they are redrawn with sensitivity as a function of clearance, as they are in Fig. 8, which gives curves for only a few frequencies, the curves then show that even at high frequencies a smooth relationship exists between the two variables. Figs. 7 and 8 serve to show the complexity of any approach to the problem of deciding the cavity shape by calculation. Whilst relationships analogous to those of the electrical transmission line are known for the probe, the problem of assigning values to the acoustical impedance of the termination with its fine dimensions is complex and not readily calculable.

ACKNOWLEDGMENTS

In conclusion, the author wishes to thank his colleagues at the Post Office Research Station for advice given on the preparation of this article. In particular he wishes to acknowledge the assistance of Mrs. A. H. Hall in many of the measurements involved.

to the completed drawing, is dealt with very adequately, and includes some of the tricks of the trade that usually are acquired only by experience. Such controversial subjects as methods of dimensioning, limits and tolerances are explained fully and the student is shown clearly the difficulties that can be overcome only by a close co-operation between the drawing office and the workshop. The lessons on screw threads, nuts and bolts, etc. are very informative and include the Unified Screw Thread and the latest ideas on locking devices.

A book of this type is very dependent upon its illustrations, and these have been thought out and prepared with care, and perspective drawings have been effectively used. C. D. L.

An Automatic-Scanning Receiver for Radio Monitoring

F. J. M. LAVER, B.Sc., A.M.I.E.E.
F. M. BILLINGHURST, B.Sc.(Eng.), A.M.I.E.E.
F. J. LEE†

U.D.C. 621.396.62

This article describes equipment which has been developed for attachment to a suitable commercial receiver for automatic monitoring of radio signals. Frequency bands between about 250 and 1,000 kc/s in width can be scanned automatically and the received signals permanently recorded on electro-sensitive paper.

Introduction.

THE work of choosing suitable frequencies for new radio-communication channels is greatly facilitated when accurate records of existing transmissions are available. Such records can be prepared only by monitoring the frequency bands for which the information is required, and hitherto they have been obtained by operators equipped with manually-tuned monitoring receivers having accurate frequency calibrations. This process is slow and tedious and many operators are needed to collect all the information that is now required. An automatic-scanning receiver has therefore been developed to carry out the most arduous part of this radio-monitoring work. It traces on a roll of sensitised paper a continuous record of all the signals that are received above a given strength, in any desired frequency band between 4,000 and 27,500 kc/s.

General description.

A sensitive gang-tuned radio receiver of commercial communications type forms the basis of the scanning receiver; however, any receiver with a single tuning control and having adequate sensitivity and selectivity can be employed, provided that it has a positive non-slip slow-motion drive. The tune-frequency of the receiver is swept over a predetermined frequency band once per two-minutes by a drive unit which is mechanically coupled to the tuning spindle. In synchronism with the tuning control, a recording device moves steadily across a chart of "Mifax" electrolytic paper and records a dot whenever a signal is picked up by the receiver at a strength higher than the minimum at which the equipment is set to operate. The intensity of the dot depends to some extent upon the strength of the incoming signal, 2 microvolts across the input terminals of the particular receiver used being the smallest signal for reliable operation below 10,000 kc/s. On this receiver, the sensitivity falls somewhat on the

higher-frequency ranges, so that, at 20,000 kc/s, 5 microvolts is the minimum signal strength for reliable recording.

The swept frequency band is represented by the width of the chart and can be adjusted as required, the smaller the frequency sweep the larger being the spacing between the traces of adjacent transmissions. A normal operating condition gives a swept band of approximately 1,000 kc/s in width for the 8 in. width of the chart. The normal chart speed is $\frac{1}{2}$ in. per hour, so that 100 ft. of chart, the standard length of a roll, will provide for 100 days continuous recording. At two-hourly intervals, the input terminals of the radio receiver are automatically disconnected from the aerial and are switched to receive frequency calibration signals. The input signal then consists of a series of 100 kc/s harmonics extending over the whole frequency range of the receiver. Whichever tuning range of the receiver is in use, the recorder marks a dot on the chart each time the frequency of tune passes a multiple of 100 kc/s. Rows of frequency markers are thus imprinted at 1-in. intervals along the length of the record, and, as the 100 kc/s harmonic is selected each time by the radio receiver itself, this calibration allows for any variations in the frequency scale of the tuning system.

The general appearance of the complete automatic-scanning receiver and a block schematic diagram are shown in Figs. 1 and 2 respectively. The tuning spindle of the radio receiver is driven by a coupling from the electrically-operated drive mechanism, the spindle being rotated slowly in a clockwise direction over a predetermined angular sweep. At the release of a magnetic clutch the tuning spindle is rapidly returned in the reverse direction to its starting point, the whole cycle of operations taking two minutes.

Working in synchronism with the tuning drive is the recorder. A wire helix fixed round the outside of a scanning drum passes slowly underneath an insulated metal strip, the writing edge, as the drum rotates. One revolution of the scanning drum corresponds to one complete tuning sweep by the scanning-drive mechanism. Damp electro-

sensitive paper is drawn by feed rollers between the helix and the writing edge, and, whenever the radio receiver is tuned to an incoming signal of suitable strength a pulse of current flows between the helix and the writing edge through the paper. At the point of contact the paper is thereby darkened, the stronger the radio signal the darker being the resulting dot. The paper must be moist for the electro-chemical action to occur, and, for this reason, the roll of paper and the scanning drum are contained in a carefully designed moisture-tight container made of perspex. As the paper passes the scanning drum it is allowed to dry, the dots then becoming permanent markings. Pen or pencil annotations

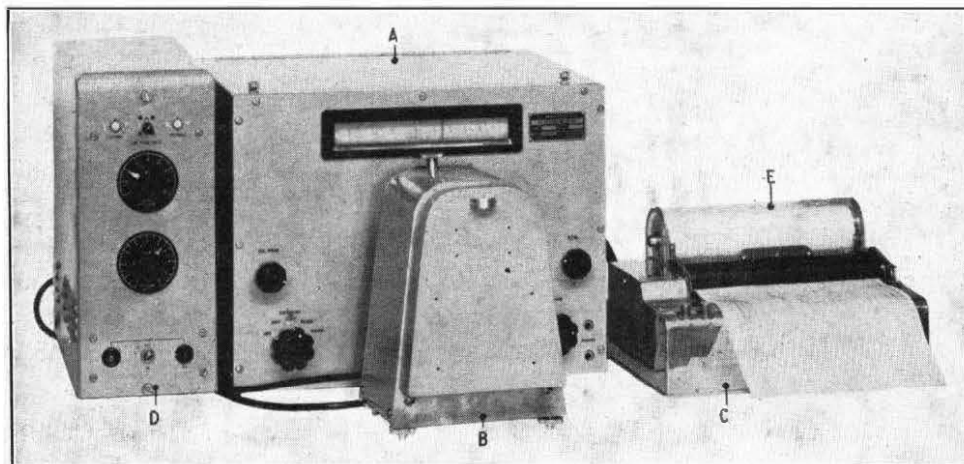

A.—Receiver Type CK100.
B.—Automatic Tuning Drive.
C.—Electrolytic Recorder.
D.—Control Unit.
E.—Moisture-Tight Paper Container.

FIG. 1.—THE AUTOMATIC-SCANNING RECEIVER.

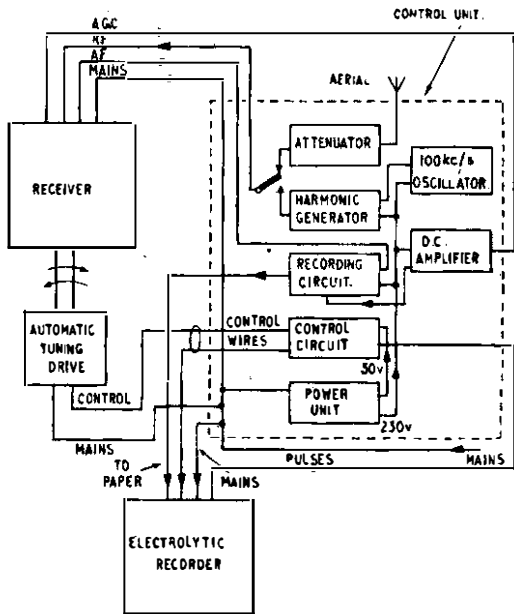

FIG. 2.—BLOCK SCHEMATIC DIAGRAM OF AUTOMATIC-SCANNING RECEIVER.

can be made quite satisfactorily on the paper when it is dry. The complete automatic-scanning receiver can be conveniently divided into four separate units.

- (a) The commercial radio receiver.
- (b) The automatic-tuning-drive unit.
- (c) The recorder.
- (d) The control and recording circuits.

Each of these will be considered in turn.

The Receiver.

The receiver must possess good selectivity and should have a signal/image ratio greater than 40 db. on all the scanned bands. Further, it is important that its noise factor should be as low as possible because the lowest signal level at which reliable recordings can be obtained depends upon the adequate separation of the wanted signal from the noise background.

The receiver should contain a beat-frequency oscillator, such as that used in reception of C.W. signals.

The Automatic-Tuning-Drive.

The drive has been designed to sweep the tuning to-and-fro over a predetermined bandwidth; the travel can be adjusted as required, the largest convenient frequency sweep being of the order of 1,200 kc/s and the smallest about 200 kc/s. The drive consists essentially of a continuously-running synchronous motor, operated from a 250 V 50 c/s supply and driving the receiver tuning shaft through an electromagnetically operated clutch. When the clutch is engaged, the tuning spindle is driven slowly in the direction of increasing frequency, a clock-spring being wound up at the same time. At the end of the forward sweep the electromagnetic clutch is de-energised by an automatic switch, thus allowing the clock-spring to return the tuning spindle quickly to the starting point.

The basic arrangement of the tuning-drive unit is shown in Fig. 3 and the manner of operation is as follows. The

unit is powered by a synchronous motor, shown on the right of the drawing, with a shaft speed of 1 r.p.m. This motor turns the armature of the magnetic clutch continuously at a steady speed predetermined by the change-gear in the train between the motor and the clutch armature. Until the clutch armature is energised, no torque is transmitted to the receiver-tuning spindle which is held at the start position by means of a spiral return spring. When the clutch armature is energised, the clutch pole plate grips and the tuning drive is rotated steadily in a clockwise direction until the clutch is released.

The tuning drive is returned by a spiral clock-spring, and to prevent the return speed from becoming excessive and thereby damaging the mechanism the speed is limited by a by-pass gear train which is brought into operation by the silent ratchet whenever the tuning shaft rotates in an anti-clockwise direction. The gear on the outer housing of the ratchet is driven continuously in an anti-clockwise direction at 20 times the forward speed of the tuning shaft. Thus when the electro-magnetic clutch is released, the spiral spring accelerates the tuning drive back towards its start position until the speed is sufficient for the ratchet to grip; the inner and outer members of the ratchet then rotate together at the speed of the outer housing of the ratchet.

This method of obtaining reciprocating motion with a fast flyback time permits up to three forward revolutions of the tuning drive in two minutes without overloading the motor. The driving load is high during the forward motion because the motor is then storing energy in the spring, for the rapid return movement, in addition to driving the tuning spindle forward. During the return movement, the motor acts as a constant speed device to limit the flyback speed to 20 times the forward speed, the driving energy for the return being drawn from the spring. If the motor were directly coupled to drive the tuning backwards at this high speed a much larger size of motor would be needed to provide the necessary peak torque.

A coupling having two flexible joints is provided with the tuning drive so that exact alignment of the drive-unit and the receiver-tuning spindles is unnecessary. With this type of coupling, it is essential, however, that the axes of the tuning spindle and the driving shaft are approximately parallel, otherwise uniform angular motion of the receiver spindle will not be obtained.

The receiver can be tuned by hand independently of the mechanical-drive unit, when the spring-loaded dog clutch coupling the unit to the receiver is released. The spring loading ensures that the dog clutch slips back to re-engage the mechanical drive as soon as the operator releases the

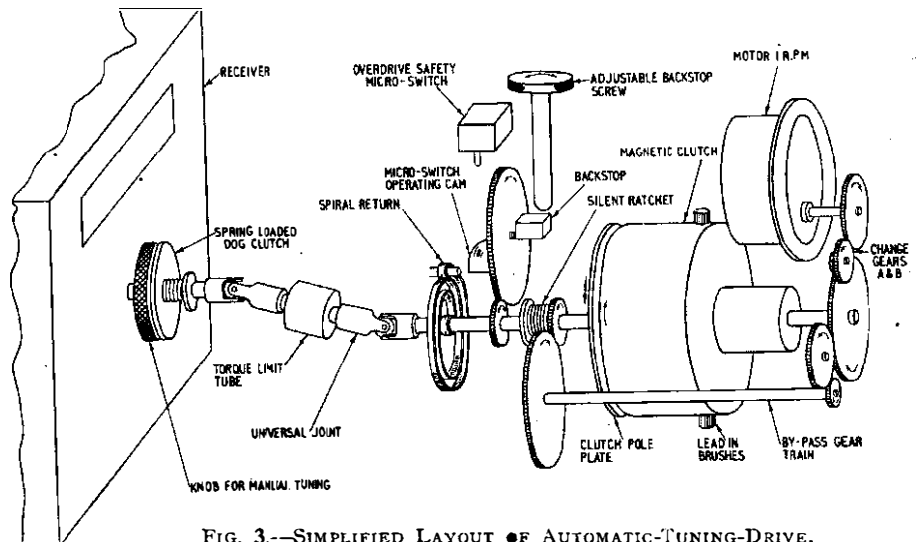

FIG. 3.—SIMPLIFIED LAYOUT OF AUTOMATIC-TUNING-DRIVE.

TABLE 1
THE AUTOMATIC TUNING DRIVE
Shaft Revolutions Obtainable with Each Change Gear

Change Gear	No. of Revolutions of Driving Shaft	
	Scanning Speed 1 line per minute	Scanning Speed 1 line per two minutes
B7	1.40	2.80
D0	1.17	2.34
B5	0.84	1.68
B4	0.70	1.40
B3	0.47	0.93
B2	0.35	0.70
B1	0.23	0.47
A1	0.19	0.37
A2	0.17	0.34
A3	0.11	0.22
A4	0.09	0.19

tuning knob.

Table 1 shows the number of revolutions of the driving shaft obtainable for scanning speeds of one line per minute and one line per two minutes. Any one of the A gears and any one of the B gears can be fitted to the mechanism at the same time, so that two ranges of scan, one large and one small, are immediately available by the operation of a gear-change lever.

The driving-spindle torque available at all speeds is not less than 500 gm. cm.

The Recorder.

The recorder produces a permanent record of the signals received, on a roll-chart $8\frac{1}{2}$ in. wide, the width dimension of the chart representing the swept-frequency band. The length of the chart gives the time of the recording on a scale of 12 in. to 24 hours. The principle is similar to that well established in facsimile recorders using "Mifax" electro-sensitive paper, and scanning is effected by means of a slowly-rotating helix which presses the paper against a knife-edge acting as stationary electrode so that where the helix and the knife edge cross each other there is a single point contact through the paper. In the scanning receiver, the rotation of the helix is synchronised with the tuning sweep, one rotation of the helix corresponding to one scan of the frequency band.

A simplified layout of the recorder is shown in Fig. 4. The damp electro-sensitive paper is drawn slowly between the helix and knife-edge and whenever a current flows between

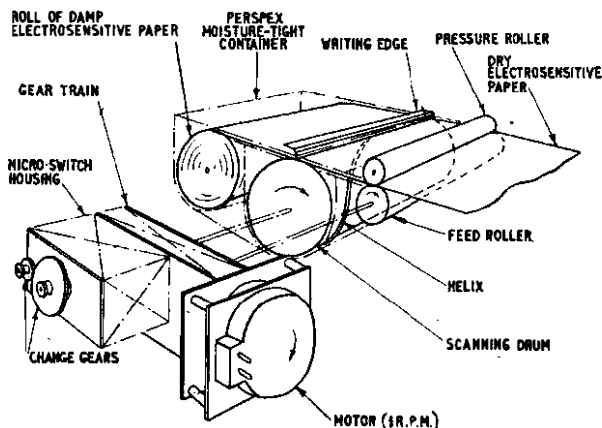

FIG. 4.—SIMPLIFIED LAYOUT OF ELECTROLYTIC RECORDER.

helix and knife-edge the paper is discoloured by electrolytic action.

The paper is stored on the recorder in a moisture-tight container and is drawn between the helix and the writing edge by two feed rollers. The lower feed-roller, which is of stainless steel, is driven by a train of gears from the helix driving-shaft, which is in turn connected by two change-gears to a small synchronous motor. This is provided with internal gearing to drive an output shaft at 1 r.p.m. The upper pressure roller is rubber faced with an accurately-ground finish and is spring-loaded to make the paper grip the feed roller.

By a suitable choice of change gears, paper speeds of $\frac{1}{2}$ in., 1 in. and 2 in. per hour are obtainable, the slowest being regarded as best for normal use. The gear ratio between the helix and the feed roller has been chosen to give 60 transverse scans for 1 in. of paper travel for all paper speeds.

The automatic-tuning-drive has been designed for a scanning speed of one complete sweep in 2 minutes, when the paper speed is $\frac{1}{2}$ in. per hour. When the higher paper speeds of 1 in. and 2 in. per hour are used the time during which the receiver tuning is driven forward per sweep is proportionately reduced. The maximum frequency band that can be scanned by the automatic-tuning-drive is therefore halved and quartered respectively at these higher paper speeds.

Mifax paper was primarily intended for high-speed recording, with paper feed-speeds of the order of 2 in. per minute and higher writing speeds of the order of 1,000-2,000 in. per minute. With the low writing speeds for which the present recorder has been designed two difficulties had to be overcome, one being that the paper, on leaving the roll, rapidly became too dry for electrolysis to take place, and the other, that "spreading" of the marking colour occurred when current was applied in roughly the same spot for an appreciable time. The first difficulty was overcome by storing the paper in a carefully designed moisture-tight container which encloses the paper right up to the recording point to minimise evaporation, and the second, by utilising the discharge of a capacitor to provide the source of current for marking the paper, giving in effect a pulse which overcomes the spreading mentioned above. Variable-density recording, which gives some indication of the signal strength by the density of the mark produced on the paper, is obtained by making the charge on the capacitor dependent on the A.G.C. voltage in the receiver. The operation of this part of the scanning receiver is described later, in the section dealing with the control unit.

Erosion of the stainless-steel writing edge must occur because the metal takes part in the chemical action of discolouring the paper, and it may become necessary in cases where a scanning receiver is monitoring the same band for periods longer than, say, two months to grind or replace the writing edge.* This is a straightforward operation. Alternatively, so that erosion does not always pit the edge in the same place, it may be possible to shift the frequency of the scanning range a little from time to time. The scanning drum does not take part in the chemical action and unless the platinum-iridium wire helix, which is relatively soft, is mechanically damaged it should last indefinitely.

Access to the roll of paper is obtained by removing a perspex cover held in position by four thumbscrews. After a new roll has been fitted, the free end of the paper is passed beneath the writing edge and between the feed and pressure rollers which, together with the writing edge, are spring loaded to rise clear of the paper when the lid of the recorder is raised. The perspex cover is then replaced, the

* It may possibly be useful to note that the extent of the erosion at any point is a measure of the extent to which the frequency corresponding to that point has been occupied by signals.

position of the paper adjusted to feed correctly and the lid of the unit is closed. This depresses the springs lifting the writing edge, so that the writing edge rests under its own weight on the paper, and also causes the paper to be gripped between the feed and pressure rollers.

The current in the coil of the electro-magnetic clutch in the automatic-tuning-drive is controlled from the recorder, where micro-switches indicated in Fig. 4 are operated by cams on the shaft driving the scanning drum. These micro-switches operate relays on the control unit. The cams are so arranged that the control pulses occur at the beginning and end of each line scanned by the helix. The timing of these pulses is such that the helix rotates 338° from the operation of the start pulse to the operation of the release pulse, allowing 22° for the flyback, corresponding to a time of 8 sec. for a scanning speed of 1 line per 2 minutes. This is two seconds longer than the automatic-tuning-drive takes to return to its start position so that there should be no chance of loss of synchronism between the receiver and the recorder. The signals intercepted by the receiver during the flyback time are not recorded. The chart has a margin of about a $\frac{1}{4}$ in. each side where signals are not printed.

A third micro-switch operated by a three-lift cam on the feed-roller shaft gives pulses occurring every two hours for disconnecting the aerial from the receiver and connecting the harmonic generator that supplies the frequency calibration signals. This gives a few lines of 100 kc/s marker points at two-hour intervals so that the chart is calibrated both for time and frequency.

A useful facility is that of being able to stop the scan at any chosen signal on the record so that the station can be identified. For this purpose, two press-button switches of the "push-on" "push-off" type are mounted on the writing table of the recorder. One switch operates a lamp situated behind the scanning drum, to silhouette the section of the helix in contact with the paper. This enables the operator to follow the actual point of recording across the chart; as this point approaches the station to be identified, the operation of the second press button switches-off the motors of both the drive and recorder. Precise tuning adjustment can then be made manually by releasing the dog clutch shown on the tuning spindle in Fig. 3.

The Control Unit.

The control unit contains the remainder of the equipment and includes the following sections.

1. The recording circuit.
2. The harmonic generator.
3. The control circuit for synchronising the recorder with the other units.
4. Power supply equipment.

The recording circuit provides the link between the receiver output and the electro-sensitive recording unit. The circuit can be considered in two parts, the first being the "printing circuit" which initiates the discharge of current giving the electrolytic action on the chart, and the second the "density circuit" which dictates the strength of the discharge according to the strength of the received signal.

The printing circuit operates as follows. The radio receiver contains a fixed frequency oscillator, known as the beat-frequency oscillator, which for the purpose of the scanning receiver, has its frequency adjusted to the middle of the receiver I.F. band. The oscillator signal is mixed with the I.F. signal, so that a difference-frequency component appears at the output of the detector.

As the frequency of tune of the receiver is swept across the frequency band, each intercepted signal in turn crosses the I.F. passband and, in beating with the signal from the internal oscillator, produces a sliding note at the output of

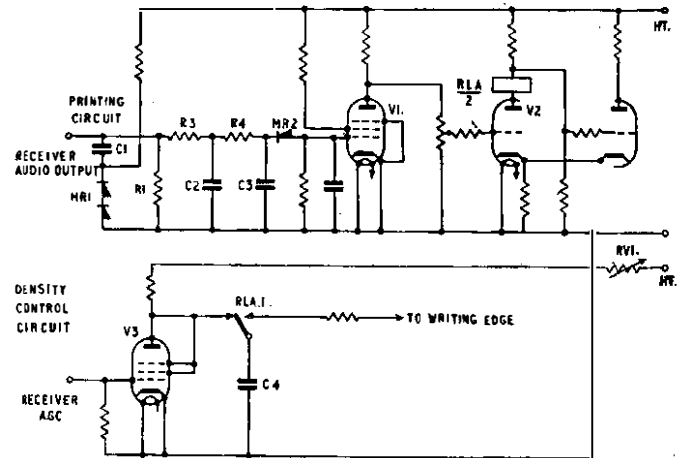

FIG. 5.—CIRCUIT DIAGRAM OF RECORDER.

the receiver. This note falls to zero frequency and rises again until the signal is swept outside the I.F. passband. The output from the anode of the last valve of the receiver is taken to the printing circuit, shown in Fig. 5, where a low-pass filter R3, C2, R4, C3, limits the upper frequency entering this circuit to approximately 400 c/s. When the sliding note resulting from a radio signal sweeps below 400 c/s, the rectifier MR2 passes a direct voltage to the grid of the D.C. amplifier valve V1, the output from which then raises the grid voltage on the first half of the double triode V2 operating in a trigger circuit. As a result, the anode current of this triode section of V2 rises sharply, operating relay RLA. This condition persists until the direct voltage applied to V1 falls to its original value, i.e. until the sliding note has passed through zero and risen again to above the filter cut-off. The trigger circuit then releases relay RLA. Owing to the slow rate of rise of attenuation of this filter, the frequency range over which the relay operates depends upon the signal strength at the input to the printing circuit, and this effect is reduced somewhat by the peak limiter consisting of MRI, C1 and R1.

The operation of relay RLA discharges the capacitor C4 through a circuit terminating in the electrodes and electro-sensitive paper of the recorder circuit, so making a brown dot on the chart.

The density of the dot is governed by the magnitude of the discharge from the capacitor, which is proportional to the voltage to which it is initially charged. This voltage is controlled in the density-control circuit, Fig. 5, by the instantaneous automatic-gain-control voltage in the radio receiver. The valve V3 acts as a D.C. amplifier, and because the A.G.C. voltage is connected to its grid, its anode voltage can be used to charge the capacitor C4 to a voltage which increases with the signal level.

For satisfactory operation of the "zero-beat" recording circuit, the frequency of the internal oscillator must be fixed at a value which gives zero-frequency beat with a signal when the receiver is exactly "on-tune," i.e. when the A.G.C. voltage is a maximum.

The harmonic generator is of conventional design and produces harmonics of 100 kc/s. The reference-frequency source is a 100 kc/s crystal oscillator built on the same chassis. A very narrow pulse is employed as the source of harmonics, and care has been taken that the levels of all harmonics between 4,000 and 27,500 kc/s do not differ too much. The variation between the levels of different harmonics over the whole of this band is of the order of 15 db. Within any 1,000 kc/s portion of the band it is less than 10 db. At two hourly intervals a low-capacitance relay is operated by a pulse from the recorder. The aerial input of

the receiver is thereby switched to the output of the harmonic generator and at the same time the H.T. supply is connected to the latter. This operation calibrates the chart for time (2 hourly intervals) and frequency (100 kc/s intervals).

The function of the control circuit, shown in Fig. 6, is to

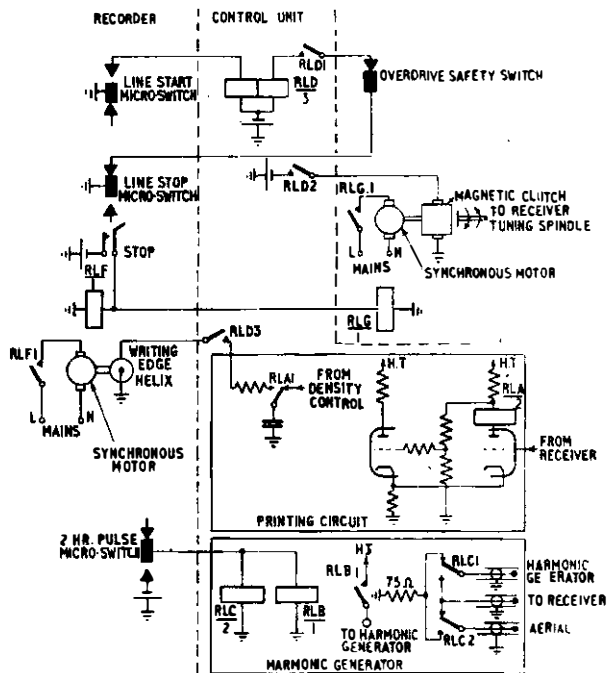

FIG. 6.—SIMPLIFIED CIRCUIT DIAGRAM OF THE CONTROL CIRCUIT.

synchronise the scanning operation of the tuning control with the mechanism of the electro-sensitive recorder. This is necessary because separate electric motors are used to drive the two mechanical sections of the equipment. The two motors have the same rate as they are synchronous motors driven from the same supply. The synchronising of the tuning is effected by micro-switches in the recorder which are actuated at the limits of the scanning cycle, thereby controlling, through relays, the magnetic clutch in the drive unit, and, once every two hours, the switching on of the harmonic generator to provide frequency-marker points on the chart. The circuit in Fig. 6 also shows the interconnections between the various units forming the whole scanning receiver.

The control circuit also houses the power switch and two adjustment facilities, an R.F. attenuator in the aerial feed to the receiver, whereby the signal-input level can be adjusted, and a "density" control (RVI in Fig. 5) which enables the operator to adjust the general intensity of marking of the chart record in the absence of radio signals.

Power for the operation of all sections of the scanning receiver is drawn from the 250 V 50 c/s supply mains. One power connection is made to a socket on the control unit, and all the other sections of the equipment receive the necessary A.C. or D.C. power by means of plug-ended cables interconnecting the various units. Two D.C. rectifier circuits are incorporated in the power unit, one supplying 300V for valve anode supplies and the other 50V for relay operation. The total power required from the 250 V A.C. supply mains for the whole scanning receiver under normal operation amounts to approximately 150W.

Field Trials.

An early model of the scanning receiver has been on field trials for nearly a year and a portion of a typical chart is shown in Fig. 7. The recorder was at this time scanning the

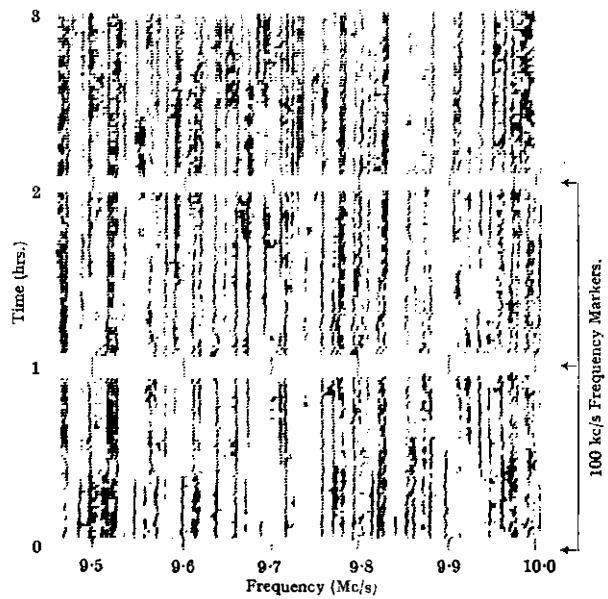

FIG. 7.—PORTION OF TYPICAL RECORD MADE BY THE SCANNING RECEIVER.

frequency band 9,000 to 10,200 kc/s and the chart speed was 1 in. per hour. The operating sensitivity was 2 microvolts E.M.F. input at the receiver terminals. The density-control circuit was operating at its maximum voltage, so that all the radio signals have, in this case, given records of approximately equal intensity.

The 100 kc/s frequency marker points can be seen in the gaps in the record which occur hourly on this equipment.

Other Possible Uses.

The automatic scanning receiver was developed as an aid to radio monitoring but it is possible that it, or some of its parts, may find other uses. Thus, the complete equipment could be connected to a coaxial cable carrying multi-channel telephony, instead of to an aerial, and could then provide a record of the variations in traffic loading of the cable over any desired period. Again the drive mechanism could be connected to a multi-point switch, in place of the tuning spindle of a radio receiver, and a record made of the variations in potentials applied to the switch contacts. For example this technique could be used for traffic studies on say 100 lines of a telephone exchange. Or records might be made of the condition of a group of alarm relays monitoring the state of unattended equipment.

Acknowledgment.

The co-operation of various colleagues in the Radio Experimental and Development Branch during the progress of this work, and in particular the assistance of Mr. C. G. Hilton, is acknowledged with pleasure.

Single-Sideband Multi-Channel Operation of Short-Wave Point-to-Point Radio-Links

F. C. OWEN and A. B. EWEN†

Part 2.—An Independent-Sideband Transmitter Drive Unit and Monitor Receiver

U.D.C. 621.396.41:621.396.619.24

The design, construction and performance of a transmitter-drive unit, and associated monitor receiver, are described. The equipment generates a low-power independent-sideband signal comprising two 6-kc/s channels, one on each side of a reduced-level "pilot" carrier, suitable for application to the final modulator and power amplifier stages of a short-wave transmitter; alternatively, a single-channel double-sideband signal can be generated. The present article is Part 2 of a series; Part 1 gave a general survey of the principles of single-sideband multi-channel operation, and subsequent articles will describe a high-power transmitter and an independent-sideband receiver.

INTRODUCTION

THE function of the drive unit is to generate a low-power two-channel single-sideband signal suitable for application to the final modulator and power amplifier stages of a short-wave transmitter. The drive unit thus forms part of an independent-sideband system, capable of transmitting two independent 6-kc/s channels, one on each side of the carrier frequency. Each 6 kc/s channel may itself be sub-divided into two 3-kc/s telephony channels or several telegraphy channels, or a combination of telephony and telegraphy channels, as discussed in Part 1 of the series.¹

The equipment described is similar in principle to earlier designs used at Post Office transmitting stations, but a number of improvements and refinements, which experience has shown to be desirable, have been incorporated.² Associated with the drive unit is a monitor receiver which provides comprehensive facilities for monitoring the signals and measuring non-linear distortion, either at the output of the drive unit, or at any of the power amplifier stages in the main transmitter.

The drive unit and monitor receiver are associated with the main transmitter as shown in Fig. 1. The independent-

output from the modulator at the frequency f_0 is selected and amplified in the transmitter to a power level suitable for application to the transmission line and aerial.

For monitoring purposes, each power-amplifier stage of the transmitter is provided with a monitor pick-up probe. A low voltage, at frequency f_0 , can thus be obtained from the selected amplifier stage and applied to a first frequency-changer located in the main transmitter. This frequency-changer is also supplied with a carrier of frequency f_3 derived from the quartz-crystal-controlled oscillator and harmonic generator and the resulting signal, in the range 3.094-3.106 Mc/s, is fed back to the monitor receiver associated with the drive unit.

THE DRIVE UNIT

Type of Signal Generated.

The drive unit accepts two separate audio-frequency signals (referred to as the channel A and B signals), each occupying a frequency band 100 to 6000 c/s, and produces an independent-sideband reduced-carrier signal with channel A above, and channel B below, the carrier at 3.1 Mc/s; the frequency spectrum of the composite signal is shown in Fig. 2.

The purpose of the carrier (referred to as the "pilot" carrier) is two-fold:—

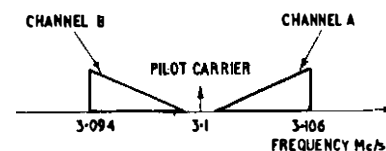

FIG. 2.—INDEPENDENT-SIDE-BAND SIGNAL PRODUCED BY DRIVE EQUIPMENT.

- It enables the automatic gain control in the distant receiver to adjust the receiver gain so that the average audio output of the receiver is correct irrespective of the actual level of the incoming radio-frequency signal.
- It enables the automatic frequency control in the distant receiver to adjust the receiver tuning so that the pilot carrier is maintained within the pass band of the narrow filter (about 40 c/s wide) which is used to select the pilot carrier from the sidebands; furthermore, it enables the received pilot carrier frequency to be synchronised with that of a local carrier oscillator which may be used to demodulate the sidebands of the received signal to audio frequency.

The level of the carrier in a single-sideband or independent-sideband signal is reduced below the level appropriate to an equivalent double-sideband signal in order that as much as possible of the radio-frequency power output of the transmitter shall be available for the information-bearing sidebands. A low level of pilot carrier is also desirable in the interests of reducing inter-channel crosstalk. The level must not be reduced too far, however, or the signal-to-noise ratio in the carrier channel of the distant receiver will be inadequate when the signal/noise ratio in the sideband channel is just adequate. A peak sideband/carrier ratio of 26 db. is

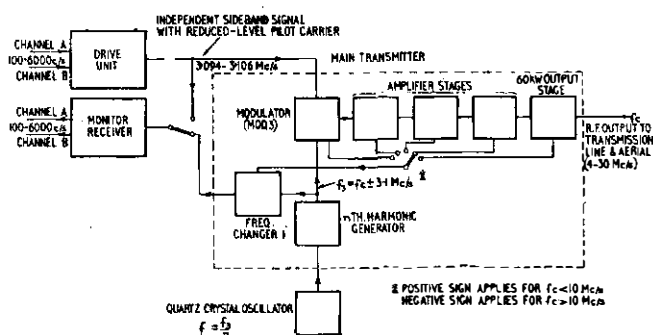

FIG. 1.—RELATIONSHIP OF DRIVE EQUIPMENT AND MONITOR RECEIVER TO MAIN TRANSMITTER.

sideband signal (3.094-3.106 Mc/s) from the output of the drive unit is applied to a modulator in the main transmitter, together with a carrier of frequency f_3 derived from a quartz-crystal-controlled oscillator and harmonic generator. The frequency f_3 is such that

$$f_3 = f_c \pm 3.1 \text{ Mc/s}$$

where f_0 is the frequency of the pilot carrier of the radiated signal. For signal frequencies below 10 Mc/s the positive sign is applicable; at 10 Mc/s and above the negative sign applies. The advantage gained by adopting this convention is that a smaller range of frequencies is required from the carrier generator than would otherwise be needed. The

† The authors are Executive Engineer and Assistant Engineer respectively, in the Radio Experimental and Development Branch, E.-in-C.'s Office.

¹ References are given at the end of the article.

used in practice in the independent-sideband system, this ratio constituting a convenient compromise between the conflicting considerations discussed above.

As discussed later the drive unit may also be used to generate a double-sideband signal when required.

Principles of Operation.

The arrangement of the drive equipment is shown schematically in Fig. 3, and the frequency spectra of the signals at the various stages are shown in Fig. 4.

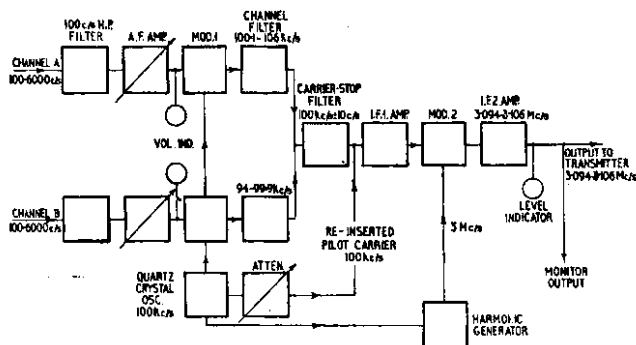

FIG. 3.—ARRANGEMENT OF TRANSMITTER-DRIVE UNIT.

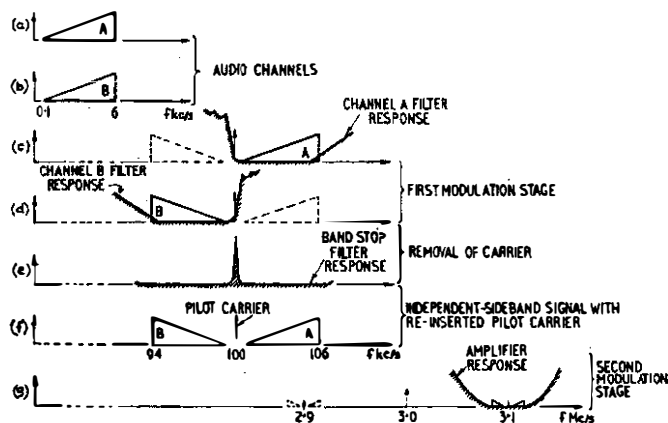

FIG. 4.—GENERATION OF INDEPENDENT-SIDEBAND SIGNAL.

The A-channel audio-frequency signals from line are first passed through a high-pass filter to remove components below 100 c/s which might otherwise produce sideband signals lying close to the pilot carrier; these signals would be accepted by the carrier-selector filter of the distant receiver and might adversely affect the operation of the receiver automatic frequency control. The 100-6000 c/s signals are then amplified, an adjustable gain-control and a volume indicator being incorporated in the audio amplifier. The amplified signals are applied to a balanced modulator (Mod. 1), together with a 100 kc/s carrier derived from a quartz-crystal-controlled oscillator. The use of a balanced modulator enables the carrier appearing in the output to be reduced to a low level relative to the sidebands. The upper sideband (100.1-106 kc/s) of the output of the first modulator in the A channel is selected in a channel filter using quartz-crystal resonators⁹ (Fig. 4(c)). A similar process is applied to the B-channel signals, except that it is the lower sideband (94-99.9 kc/s) of the output of the first modulator in the B channel which is selected (Fig. 4(d)). The channel filters provide a very high degree of discrimination against the unwanted sideband, so that the output from each channel is substantially a single-sideband signal.

The A-channel and B-channel signals (100.1-106 kc/s and 94-99.9 kc/s respectively) are then combined by means of a hybrid transformer. The residual carrier left as a result of the

imperfect balance of the first modulators and the relatively small rejection of the channel filters at 100 kc/s is removed by a carrier-stop filter (Fig. 4(e)). This is a quartz-crystal filter which freely transmits frequencies in the ranges 94 to 99.9 kc/s and 100.1 to 106 kc/s but offers at least 30 db. discrimination against frequencies of 100 kc/s \pm 10 c/s. The pilot carrier, which is derived from the 100 kc/s oscillator, is then combined with the independent-sideband signal by means of a second hybrid transformer (Fig. 4(f)).

The reason for partially balancing out the carrier in the first modulators and removing the residual carrier by means of a carrier-stop filter is that the final carrier level is then determined mainly by that of the re-inserted carrier and is almost completely independent of small fortuitous changes in modulator balance, such as might be caused by ageing of components. It is important, in an independent-sideband system, that the peak-sideband to pilot-carrier level ratio should remain constant, otherwise the audio-frequency output of the distant receiver will vary.

The composite signal consisting of the upper and lower sidebands and the pilot carrier is amplified and applied to a second balanced modulator (Mod. 2), together with a 3 Mc/s oscillator supply derived from the 100 kc/s oscillator by frequency multiplication. A second intermediate-frequency amplifier (I.F.2) selects the required upper sideband (3.094-3.106 Mc/s) and provides a certain amount of rejection of the 3 Mc/s component (Fig. 4(g)); further rejection is achieved by the balance of the second modulator.

The peak-sideband-output level of the I.F.2 amplifier (+ 24 db. relative to 1 mW) is measured on a calibrated voltmeter; the pilot-carrier level may also be measured on the same meter (in the absence of a sideband signal), a change of voltmeter sensitivity being made to accommodate the low level of the pilot carrier.

The drive unit may also be used to generate a double-sideband signal consisting of a modulated 3.1 Mc/s carrier. For convenience, and in the interests of economy of equipment, the same modulation processes are used as in independent-sideband operation. The audio-frequency signal is applied to one channel only; the channel filters are switched out of circuit and the re-inserted carrier is increased to the level appropriate for double-sideband working. This method of generating a double-sideband signal requires equal phase differences (apart from sign) between the carrier and the upper and lower sideband components; a means is therefore provided for adjusting the phase of the re-inserted carrier during installation.

Requirements of the Oscillators.

Radio Frequency Oscillators.—The frequency error of the carrier radiated by a short-wave transmitter employed in point-to-point communication must not exceed the value of 30 parts in 10^6 permitted by International Regulations⁴; the oscillator stability requirements are therefore stringent.

The frequency error of the carrier (f_c) radiated by an independent-sideband transmitter depends on the frequency errors of the oscillations from which the radiated carrier is derived, i.e., the 100 kc/s and 3 Mc/s oscillations applied to the first and second modulators, in the drive equipment, and the conversion frequency at ($f_c \pm 3.1$ Mc/s) applied to the third modulator, in the transmitter. The largest percentage error will occur when a relatively low-frequency carrier (e.g., 4 Mc/s) is derived by applying a conversion frequency of 7.1 Mc/s (nominal) to the third modulator together with 3.1 Mc/s (nominal) from the drive unit, and the frequency errors of the 100 kc/s and 7.1 Mc/s oscillations are of opposite sign. In this case, the percentage frequency error of the radiated carrier is $2.55 p$, where p is the (equal) percentage error of the 100 kc/s and 7.1 Mc/s oscillations. To meet the requirements stated above, it follows that the long-term

frequency error of the 100 kc/s and conversion-frequency oscillators should not exceed $0.003/2.55 (= 0.0012 \text{ per cent})$ i.e., 12 parts in 10^6 .

For the regular scheduled radio-communication services of the Post Office the conversion frequencies are obtained from crystal-controlled oscillators operating in the range 3 to 7 Mc/s. Frequency multiplication, in a harmonic generator, is employed to cover the conversion-frequency range of 6.9 Mc/s to 26.9 Mc/s necessary to produce radiated frequencies of from 4 to 30 Mc/s.

In a transmitting station containing several independent-sideband transmitters the 100 kc/s and 3 Mc/s oscillations can be conveniently obtained from a central source consisting of a 100 kc/s quartz-crystal-controlled oscillator and a 30-th harmonic generator for the 3 Mc/s oscillation. There it may be economical to provide a very stable 100 kc/s oscillator in order to reduce the tolerances on the oscillators feeding the third modulators in the transmitters; five or more of the latter oscillators may be required for each transmitter for the various frequencies on which it may work, whereas one 100 kc/s oscillator can feed all the transmitter-drive units. In practice it is possible to keep the 100 kc/s supply (and therefore the 3.1 Mc/s output of the drive unit) within 1 part in 10^6 of the nominal frequency, monthly checks of frequency being made against a suitable standard to allow for ageing effects. Under these conditions the maximum frequency error of the radiated carrier is $1.88 p_0$, where p_0 is the percentage error of the conversion-frequency oscillation applied to the third modulator; it follows, therefore, that the long-term error of the conversion frequency should not exceed $0.003/1.88 (= 0.0016 \text{ per cent.})$ i.e., 16 parts in 10^6 .

Audio Frequency Oscillators.—Two audio-frequency test-tone oscillators mounted on the same chassis are provided for the efficient line-up and maintenance of the independent-sideband equipment. To ensure that the distortion measured by the monitor receiver (as described in the next section) is not significantly modified by any inter-modulation in the oscillators, arising from crosstalk between them, it is specified that the level of the intermodulation product $(2f_a - f_b)$ present in the output of either oscillator should not exceed -60 db. relative to the fundamental level. The frequency stability requirements of the oscillators are determined by the bandwidth of the distortion filter; a tolerance of $\pm 1 \text{ per cent.}$ is sufficient to ensure that the distortion component will remain within the pass-band. The oscillator frequencies (1100 and 1775 c/s) were chosen in order to obtain maximum rejection of the difference frequency $(f_b - f_a = 675 \text{ c/s})$ in the distortion filter, which offers maximum discrimination to frequencies 250 c/s away from the mid-band frequency.

THE MONITOR RECEIVER

Principles of Operation.

A block schematic diagram of the equipment provided for monitoring the sideband and carrier signals is shown in Fig. 5. The equipment is designed to accept signals from the drive unit at 3.1 Mc/s or from the various power amplifier stages of the transmitter at the radiated frequency. The latter signals are first translated to 3.1 Mc/s in a frequency-changer unit located at the transmitter.

The oscillator frequencies required by the monitor equipment for frequency changing and demodulation are:—

- Conversion frequency from the transmitter harmonic generator,
- 3 Mc/s from the drive unit frequency converter,
- 100 kc/s from the drive unit crystal oscillator.

Since the first frequency-changer is permanently associated with the transmitter harmonic generator, the act of tuning the transmitter automatically ensures that the

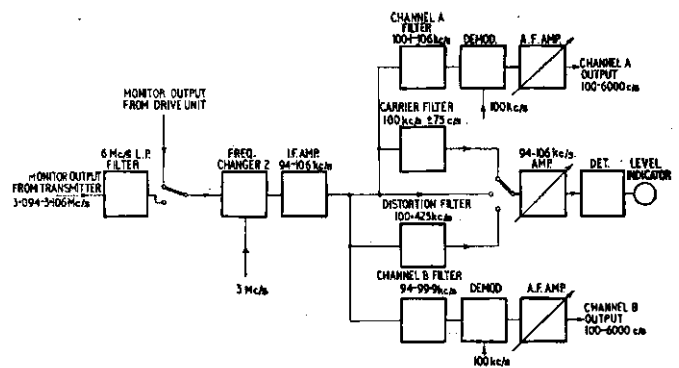

FIG. 5.—BLOCK SCHEMATIC DIAGRAM OF MONITORING EQUIPMENT.

frequency-changer is supplied with the appropriate conversion frequency; in practice, therefore, the monitor equipment is aperiodic over the working frequency range. Any conversion frequency present in the output of the first frequency-changer is virtually removed by passing the 3.1 Mc/s signal through a 6 Mc/s low-pass filter. The 3.1 Mc/s signal is then applied to a second frequency-changer which translates the signal to the range 94-106 kc/s. After a stage of amplification the signal path is divided, by means of hybrid transformers, into five paths. Two of these outlets are for aural monitoring purposes, the A and B channel signals being selected in quartz-crystal filters (similar to those used in the drive unit) and then demodulated in separate balanced demodulators.

Measurement of Carrier and Sideband Levels, and Non-Linear Distortion.

The measurement of the sideband, carrier and distortion components is carried out at the 100 kc/s stage, the measuring equipment consisting of a 94-106 kc/s amplifier-detector preceded by a calibrated adjustable attenuator. By means of a switch the measuring equipment may be connected to any one of the following:—

- a narrow-band carrier filter (100 kc/s $\pm 75 \text{ c/s}$) for selecting the pilot carrier,
- a narrow-band distortion filter (100.425 kc/s $\pm 75 \text{ c/s}$) for selecting the distortion component, and
- the unfiltered sideband output (94-106 kc/s) of the monitor receiver.

Condition (a) enables the pilot carrier level to be monitored continuously on the amplifier-detector meter and an alarm circuit, associated with the meter valve, can be arranged to give remote visual or aural warning, or both, if the carrier level departs from its correct value. Condition (a) also enables carrier compression (resulting from, for example, poor regulation of the transmitter power supplies), which may occur during passages of deep modulation, to be observed readily.

Conditions (b) and (c) enable the equipment to be used for measuring the level of the third-order distortion in the drive unit or the transmitter. The criterion of non-linear distortion produced in the system is the level of a third-order intermodulation product produced when two equal-amplitude tones are applied simultaneously to the same channel. The tones, of frequencies $f_a = 1100 \text{ c/s}$ and $f_b = 1775 \text{ c/s}$, are applied to the A channel of the drive unit. When translated to radio frequency, the signal consists of two components of frequencies $(f_c + f_a)$ and $(f_c + f_b)$, where f_c is the frequency of the carrier. Non-linearity of the transmitter or the drive unit gives rise to third-order intermodulation products of the type $2(f_c + f_a) - (f_c + f_b) = f_c + 2f_a - f_b$, and higher orders. For the particular tone frequencies used a third-order distortion component of frequency $(f_c + 425) \text{ c/s}$ is chosen; when translated to the

band 94-106 kc/s this third-order distortion component lies at 100.425 kc/s and this is the component selected by the distortion filter in condition (b). The distortion level is expressed relative to the level of either of the two tones; the sideband signal level is measured in condition (c), one tone at a time being applied to the drive unit.

Although the two-tone method of measuring transmitter distortion has been widely used in the past, an improved technique using an input signal consisting of random noise instead of the tones has recently been developed⁵ and is outlined in the Appendix.

PERFORMANCE CHARACTERISTICS OF THE DRIVE UNIT Levels.

When either channel is energised by a single tone, the drive unit is capable of delivering an output at 3.1 Mc/s of +18 db. relative to 1 mW for an input signal range of -22 to +24 db. relative to 1 mW. The peak sideband output when both channels are energised simultaneously, or when the input to one channel is increased 6 db. above normal tone level, is +24 db. relative to 1 mW. When speech is applied to the channels, the peak sideband output should not exceed +24 db. relative to 1 mW for an adequate performance as regards inter-channel crosstalk; the true peaks of speech are not, however, indicated on the output meter because of its relatively long time-constant.

Frequency-Response Characteristics.

The overall frequency-response for input frequencies between 200 c/s and 6000 c/s is substantially that of the channel-selecting filters, as shown in Fig. 6(a). Fig. 6(b)

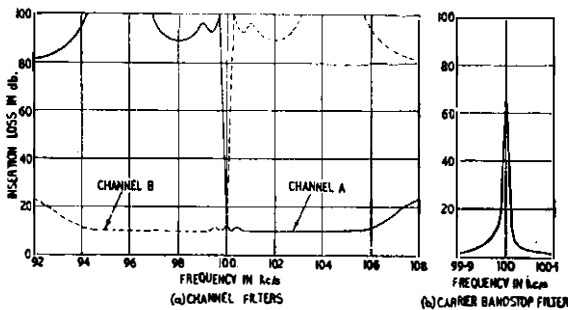

FIG. 6.—INSERTION-LOSS/FREQUENCY CHARACTERISTICS OF CHANNEL AND CARRIER-STOP FILTERS.

shows the insertion-loss characteristic of the stop filter used to attenuate the 100 kc/s out of balance component.

A typical overall frequency-response measured at the drive output for various frequencies applied to the input is shown in Fig. 7. The overall frequency-response of the channels does not vary by more than 1.5 db. from 200 c/s to 6000 c/s, relative to the maximum response in the pass-band. The response at 100 c/s is -3 db. relative to that in the pass band and it decreases rapidly at a rate of more than 20 db. per octave for lower frequencies, for reasons discussed earlier.

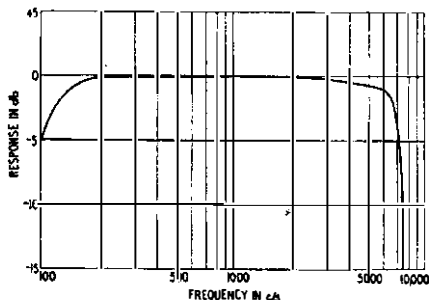

FIG. 7.—OVERALL AUDIO-FREQUENCY RESPONSE CHARACTERISTIC.

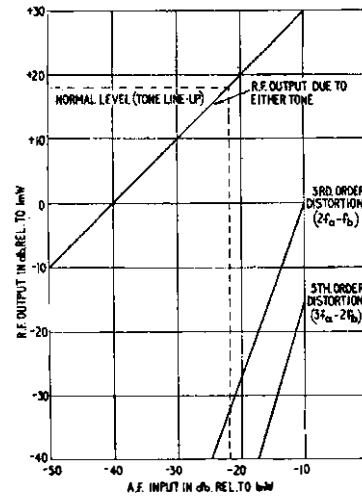

FIG. 8.—OVERALL LINEARITY CHARACTERISTIC.

Non-linear Distortion.

The overall relationship between the audio-frequency input level and the sideband output level is shown in Fig. 8. This also shows the manner in which the levels of the third-order and fifth-order intermodulation products ($2f_a - f_b$) and ($3f_a - 2f_b$) vary as the level of the two equal-amplitude audio tones (f_a and f_b) is varied; these components are at least 47 db. and 60 db. respectively below the standard level of the test-tone.

Carrier Compression and Unwanted Phase Modulation.

Non-linear amplification may also result in a reduction of the carrier level at the output of the drive unit when an audio signal is applied to the input; this effect is known as "carrier compression." If the amount of carrier compression is excessive it results in a corresponding change in the audio output of the distant receiver, due to its automatic gain control. In the present design of drive unit the carrier compression at peak-sideband-output level does not exceed 0.5 db., which is negligible.

Tests have also been made to determine the amount of unwanted phase-modulation present at the output of the drive unit. Such modulation can arise if the resonant frequency of a tuned-amplifier stage changes during the modulation cycle, due, for example, to a change in the input capacitance of the valve, caused by over-loading. Phase modulation is undesirable in a multi-channel system because the sideband components thus produced can give rise to inter-channel crosstalk. The extent to which the pilot carrier in the drive unit is phase-modulated as a result of the presence of a sideband signal can be used as a measure of the phase-modulation. It was found that, for any level of sideband signal up to that which produced peak output power, the unwanted phase modulation did not exceed one degree (the limit of measurement) corresponding to a signal-to-crosstalk ratio exceeding 40 db.

DESIGN DETAILS OF THE EQUIPMENT

Modulators.

The first and second modulators in the drive unit and the demodulators in the monitor receiver are of the balanced type employing pentode valves; the carrier is applied in phase, and the signal in phase-opposition, to the two signal grids. Amplitude balance is provided by adjustment of the screen potential of one modulator valve of a balanced pair.

Quartz-Crystal Filters.

A high degree of discrimination against the unwanted sideband signals, and a uniform transmission over the desired frequency range are the main requirements of the channel filters.³ Each filter consists of two half-lattice sections, using a total of four wire-mounted 0° X-cut quartz-crystal resonators in evacuated glass envelopes. For the upper sideband channel filter, one section has three infinity points located in the stop-band on the low-frequency side of the carrier, while the other section has two infinity points on the low-frequency side of the carrier and one in the stop-band on the high-frequency side. Input and output transformers are provided to enable unbalanced 75-ohm connections to be made to the filters.

In the carrier-stop filter two bridged-T sections are used with one wire-mounted 0° X-cut resonator in each section. Input and output transformers are provided for 75-ohm unbalanced connections.

Each of the three sections of the carrier-pass filter used in the monitor equipment is of the half-lattice form and contains two wire-mounted X-cut resonators, together with a differential transformer. The transformers of the two end sections enable 75-ohm unbalanced connections to be made. The filter is designed to provide three peaks of loss on each side of the pass-band. The distortion filter is similar to the carrier-pass filter, but has its mid-band frequency at 100-425 kc/s.

All of the crystal filters referred to are hermetically sealed and the outside dimensions enable each filter to be mounted on a panel 19 in. wide and 3½ in. deep, under a 6 in. dust cover.

Oscillators.

The 100 kc/s oscillator is a single-valve oscillator, controlled by a +5° X-cut bar crystal mounted in an evacuated glass envelope. The oscillator is not temperature-controlled.

The 3 Mc/s oscillations are derived from the 100 kc/s oscillator by means of a frequency-multiplier employing three stages of multiplication ($3 \times 5 \times 2$). A high degree of rejection of the component at 3.1 Mc/s is essential because it coincides with the frequency of the pilot carrier at the second modulator; by using three stages of multiplication adequate discrimination against this component is readily obtained.

The oscillators described above are those incorporated as part of the drive unit; as has already been mentioned, a centralised 100 kc/s oscillator and 3 Mc/s harmonic generator can conveniently be used at large transmitting stations where several independent-sideband transmitters are installed. In such a case power amplifiers and distribution networks are provided for distributing the 100 kc/s and 3 Mc/s supplies to the various drives; all the frequency-generating equipment is duplicated to ensure reliability and to provide for convenient maintenance.

MECHANICAL CONSTRUCTION OF THE UNITS

With the exception of the first frequency-changer of the monitor receiver, the drive and monitor equipment is assembled on both sides of a single 6 ft. 6 in. rack; a photograph of the front of the rack is shown in Fig. 9. Apart from the filters and oscillators, the drive equipment is located in two main units. One contains the audio-frequency amplifiers, volume indicators and first modulators for both channels and the second contains the common 100 kc/s amplifier, the second modulator and the 3.1 Mc/s amplifier. The sideband-level controls are mounted on the first, and the re-inserted-carrier-level control on the second, of these units.

The monitor equipment also consists of two main units; the monitor receiver, which demodulates the 3.1 Mc/s signal to A.F., and the carrier and distortion-measuring equipment.

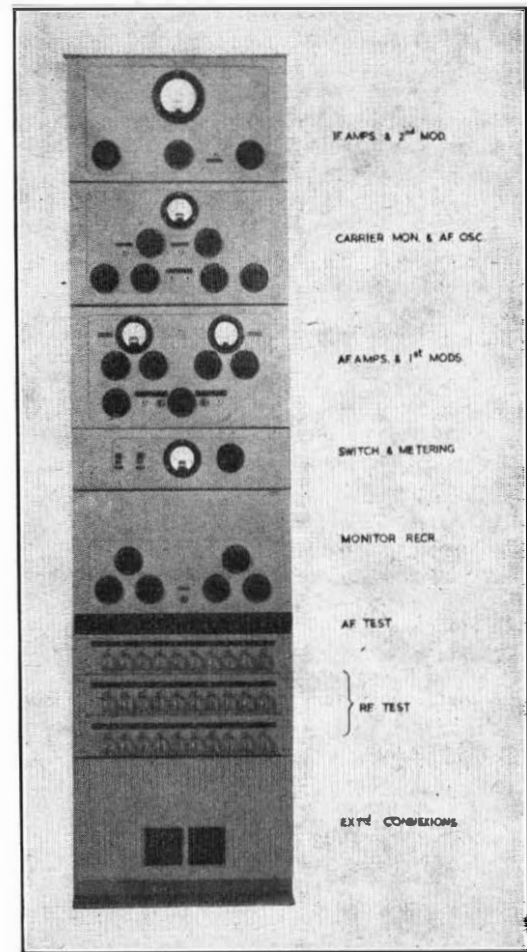

FIG. 9.—FRONT VIEW OF DRIVE AND MONITOR EQUIPMENT.

The latter contains the test-tone oscillators as well as the 100 kc/s amplifier-detector. Each of the four main units referred to above may be partially withdrawn from the rack and tilted for inspection. All connections to these units are made through plugs and sockets on associated mounting plates so that a unit may readily be withdrawn completely from the rack if more detailed inspection and maintenance are required. A photograph of a typical unit is shown in Fig. 10.

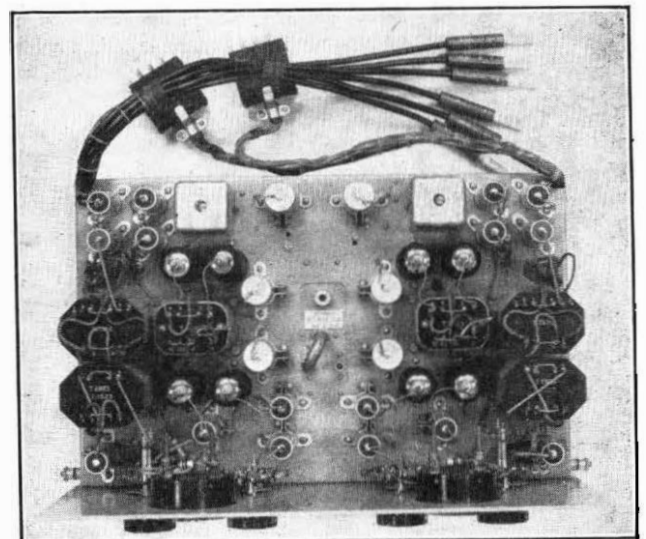

FIG. 10.—A TYPICAL CHASSIS (AUDIO-FREQUENCY AMPLIFIER AND 1ST MODULATOR).

The 100 kc/s oscillator and the 3.0 Mc/s frequency-multiplier also use plugs and sockets for connection to external wiring, the units consisting of small chassis bolted to mounting plates.

Two identical power units are provided on the rack; one supplies H.T. and heater power to the drive equipment, including the R.F. oscillators, and the other supplies the monitor receiver.

Intermediate-frequency connections between units are made by coaxial cable, U-links being provided on a test panel to facilitate testing. Similarly, an A.F. test panel is provided for connections between A.F. units.

CONCLUSIONS

The performance of the new design of independent-sideband transmitter drive represents an improvement, as compared with earlier designs, in respect of reduced susceptibility of the monitor receiver to unwanted pick-up from the stray fields of high-power transmitters in the same building, less critical modulator balance, ease of access to the various units for maintenance purposes, and economy of rack space. The linearity of the drive unit and the freedom from inter-channel crosstalk, are more than adequate for present requirements.

The comprehensive monitoring and measuring facilities provided have proved of considerable value in achieving and maintaining a high standard of performance in independent-sideband systems.

APPENDIX

AN ALTERNATIVE METHOD OF MEASURING NON-LINEAR DISTORTION

If a band of random noise, 6 kc/s wide, is applied to, say, the A channel of the drive unit, the distribution of the intermodulation products at the output of the system (due to non-linear distortion) will be approximately as shown in Fig. 1. By sampling the noise power at specified points in the

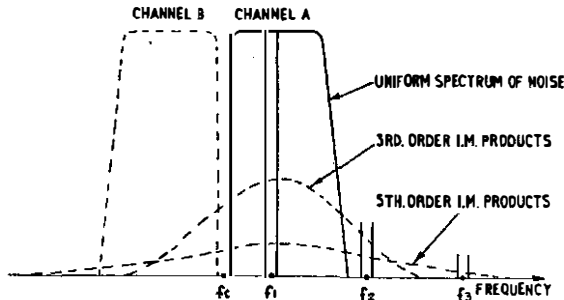

FIG. 1.—DISTRIBUTION OF 3RD AND 5TH ORDER INTERMODULATION PRODUCTS.

output-frequency spectrum, using measuring equipment having a bandwidth narrow compared with 6 kc/s, a measure of the level of the third- or fifth- order intermodulation products is obtained. It can be shown that, for a channel bandwidth of 6 kc/s, intermodulation noise in a narrow band centred at f_2 ($= f_c \pm 9$ kc/s) consists mainly of third-order products; the higher odd-order components, which are also present, are relatively much lower in amplitude. Similarly, intermodulation noise at f_3 ($= f_c \pm 15$ kc/s) consists mainly of fifth-order products. Tests on the drive unit have shown that the third-order distortion, expressed as a ratio of the noise powers measured at f_1 (any frequency within the pass-band of the energised channel) and f_2 , agrees closely with the ratio obtained with the two-tone method, when the latter is free from the anomalous effects discussed below. The power level of the noise applied to the input of the drive unit was adjusted to be equal to the tone line-up level, i.e., 6 db. below the tone level corresponding to peak output power. At this level the instantaneous peaks of the random noise exceeded the nominal peak output level of the drive unit for only 0.5 % of the time.

For routine test purposes it is not essential to measure the intermodulation noise in a bandwidth narrow compared with 6 kc/s; it is sufficient if random noise of a suitable level is applied to one channel input of the drive unit and the "signal" and "crosstalk" noise powers are compared at the A and B channel audio-frequency outputs of the monitor receiver.

The chief advantages of the random noise method of distortion measurement are as follows:—

- (a) Experience with the two-tone test has shown that the level of the third-order distortion product can vary irregularly with the level of the tones, in fact, partial cancellation can occur at certain levels giving an incorrect impression of the amount of crosstalk present, for example, with telephony signals; this difficulty is avoided by the random noise technique, the "signal" then being more representative of a telephony signal than is the case with only two tones.
- (b) All intermodulation products, irrespective of their order, which fall in the band selected (and which would, therefore, cause inter-channel crosstalk or adjacent channel radiation in practice) are measured.

References.

- ¹ "Single-Sideband Multi-Channel Operation of Short-Wave Point-to-Point Radio Links, Part 1—General Survey," W. J. Bray and D. W. Morris, *P.O.E.E.J.*, Vol. 45, p. 97.
- ² "The Design of Transmitter Drives and Receivers for Single-Sideband Systems," W. J. Bray, H. G. Lillicrap and W. R. H. Lowry, *J.I.E.E.*, Vol. 94, Part IIIA, No. 12, p. 298, 1947.
- ³ "Crystal Filters for Radio Receivers," C. F. Floyd and R. L. Corke, *J.I.E.E.*, Vol. 94, Part IIIA, No. 16, p. 915, 1947.
- ⁴ Radio Regulations, Atlantic City, 1947. Appendix 3, p. 225E.
- ⁵ "Methods of Measuring Adjacent Band Radiation from Radio Transmitters," N. Lund, *Proc.I.R.E.*, Vol. 39, No. 6, p. 653, June, 1951.

Book Review

"Fundamentals of Technical Electricity." H. G. Mitchell, M.A., B.Sc. Methuen & Co. Ltd. 543 pp. 11 plates. 346 diagrams. 18s.

This book attempts to present to the student reading for the early stages of an Engineering Degree, the Ordinary National Certificate, or Grades 2 and 3 of Telecommunications Principles of the City and Guilds of London Institute, the general principles of elementary A.C. and D.C. circuit and instrument theory rather than methods whereby engineers employ them in technical work. The atmosphere created is nearer that of the physics than the electrical engineering laboratory. Amongst the many text books on elementary technical electricity published in recent years this one stands out on account of its more academic approach. The need for the passing of examinations has not however been in any sense overlooked, as the author has introduced worked examples to help the student in

"getting down to earth," and has added numerous unworked exercises drawn largely from past City and Guilds papers in Telecommunications Principles, at the end of each chapter.

The mathematical treatments are well presented in concise unabbreviated form. Elementary Calculus is used where necessary: vectors are employed freely, and the "j" notation is introduced towards the end of the book for use in the solution of resonant and mutually coupled circuits, and simple A.C. bridge networks. A chapter on Units and Dimensions, with an account of the Rationalised M.K.S. system, is included, followed by short chapters on theory of conduction, elementary thermionic valve applications, and modern views on energy and radiation. The text is liberally illustrated with diagrams of excellent clarity and the publishers are to be congratulated on the quality of the paper and printing, which has resulted in a volume that is pleasing to handle and to read. C. F. F.

C.C.I.F. Field Trials of International Semi-Automatic Telephone Operation

J. V. MILES†

Part 2.—Facilities to be provided

U.D.C. 621.395.35: 621.395.5

In this concluding part of the article the author discusses the principal facilities to be provided in the field trials of the international semi-automatic telephone system. Brief reference is also made to the arrangement of equipment at the London centre.

FACILITIES TO BE PROVIDED

General.

THE Field Trial equipment used by all participating countries will be constructed in accordance with the standard specifications, which permit Administrations to use their own particular switching techniques but ensure satisfactory interworking between countries.

In the arrangements for the London Centre, Fig. 3, motor uniselectors, common marker controlled, are employed for high speed switching and all V.F. signals are sent from the line relay sets. This latter feature contrasts with the corresponding methods commonly adopted at the other field trial centres, where, with a more general technique of using link circuits, a proportion of the signals will usually be sent from common equipment.

It is usual, in pulse signalling systems, to send a seizing signal from the outgoing exchange to initiate the necessary circuit conditions at the incoming exchange for the receipt of subsequent signals. Thus, the receipt of a seizing signal at the incoming exchange may be used to cause an incoming register to become associated with the calling line. Where, however, mixed terminal and transit traffic must be catered for, and it is desired to use different registers for these two types of traffic, a means must be found for connecting the appropriate type of register (i.e. transit or terminal) to the calling line. This has been catered for in both of the trial international signalling systems by the use of two different types of seizing signals. The signal to be used is determined by the outgoing or intermediate transit register, having regard to the destination of the call

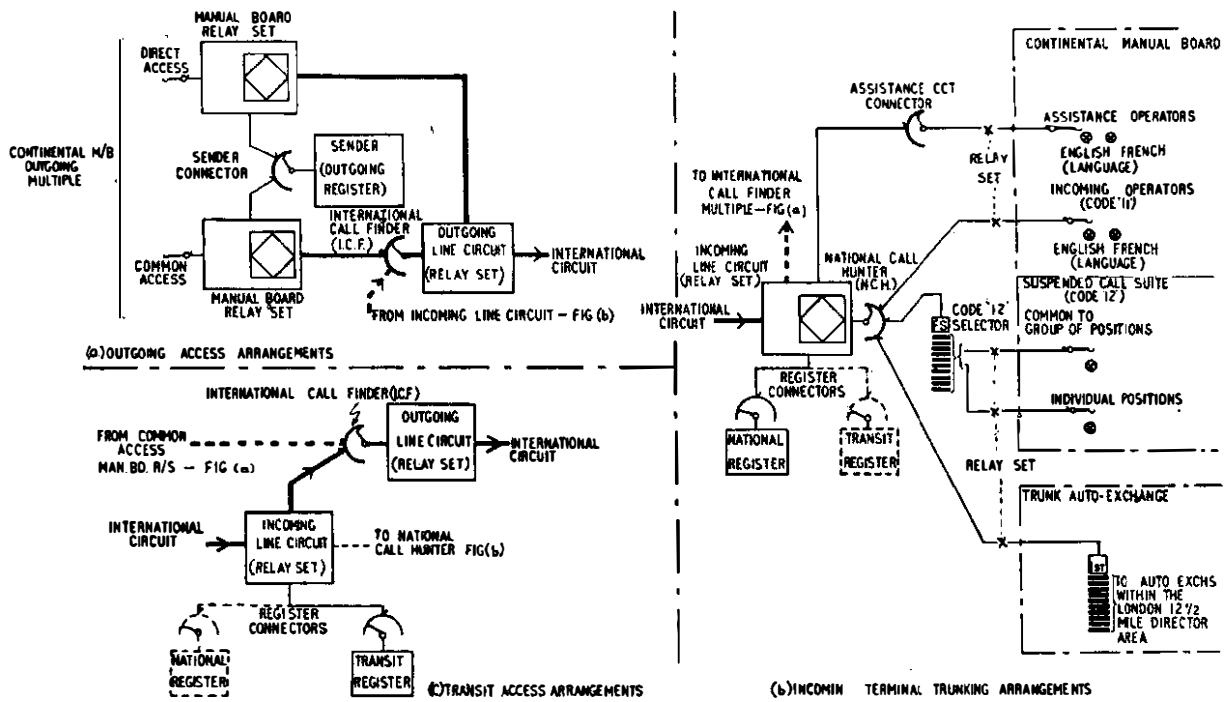

FIG. 3.—TRUNKING OF THE LONDON EQUIPMENT FOR BOTH 1 V.F. AND 2 V.F. SYSTEMS.

To obtain the fullest information on the adequacy of the two signalling codes to cater for the ultimate requirements of an international signalling system, it has been agreed that transit switching involving not more than one transit exchange, or exceptionally two transit exchanges, and automatic alternative routing shall be provided for initially, in addition to a direct terminal service. It was also agreed that all international semi-automatic circuits shall be operated on a unidirectional basis.

† Assistant Engineer, Telephone Development and Maintenance Branch, E.-in-C.'s Office.

(as indicated by the country code) and to the actual route selected. Thus, if a direct route to the country of destination is taken, a terminal seizing signal is sent and if an indirect route is taken, a transit seizing signal is sent.

Control of Digit Sending.

In register systems use can be made of the storage facilities to delay the transmission of the digital information until the distant exchange is ready to receive it. In each of the international signalling systems the release of the digital information is effected under the control of a

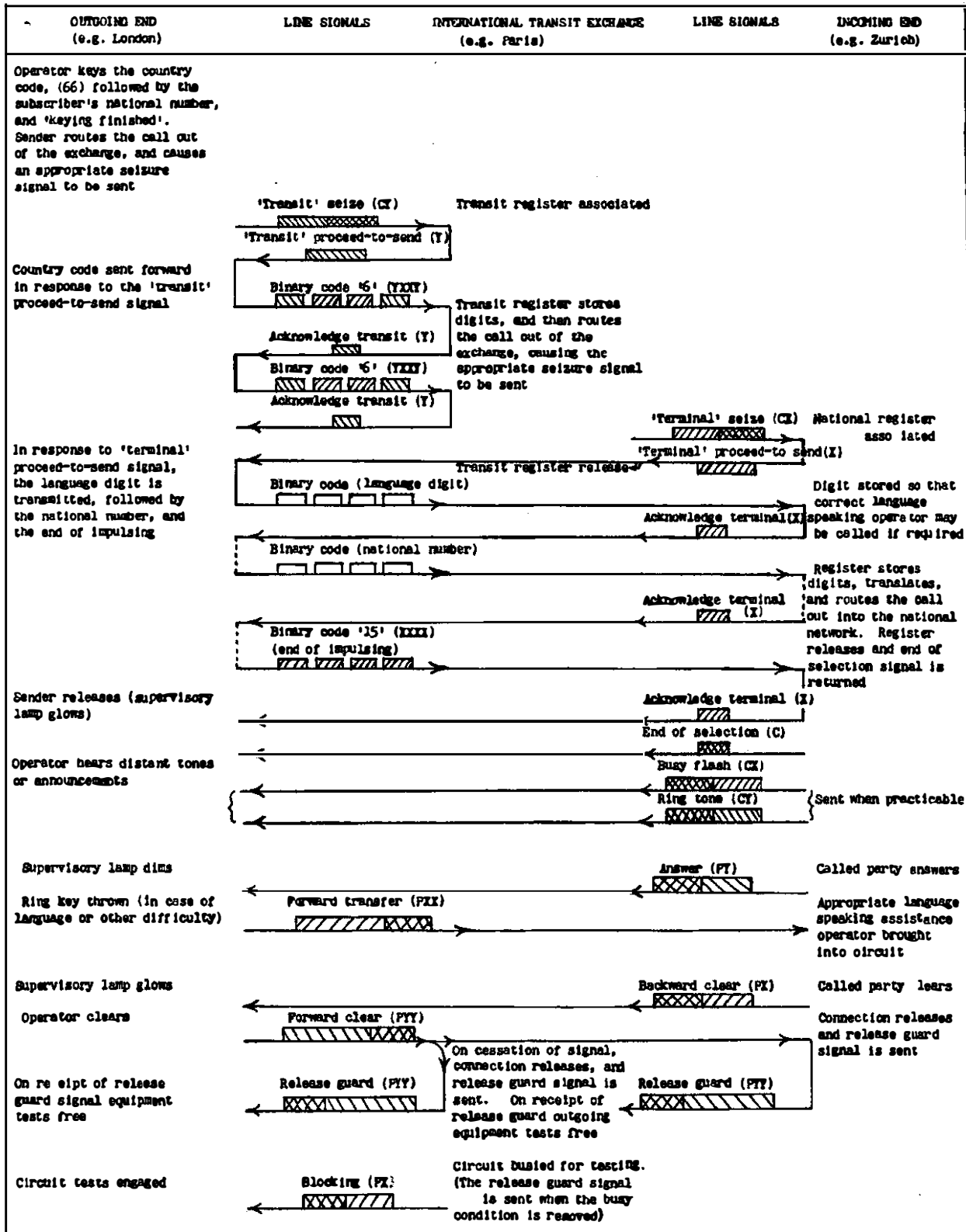

FIG. 4.—APPLICATION OF THE SIGNAL CODE—2 V.F. SYSTEM.

proceed-to-send signal which is returned from the incoming exchange when a register has been associated with the calling line after the receipt of a seizing signal.

Although this principle is the same with both signalling systems, there is an important difference between the two signalling systems on transit switched calls, which needs some explanation. With the single frequency system, on transit connections, the whole of the digital information,

including the country code, is passed progressively from exchange to exchange each time a proceed-to-send signal is received, until the penultimate exchange is reached. The transit register at this exchange then sends a terminal seizing signal and, on the receipt of a proceed-to-send signal, sends only the national number to the international terminal exchange. With the two-frequency signalling system, the outgoing terminal register maintains full

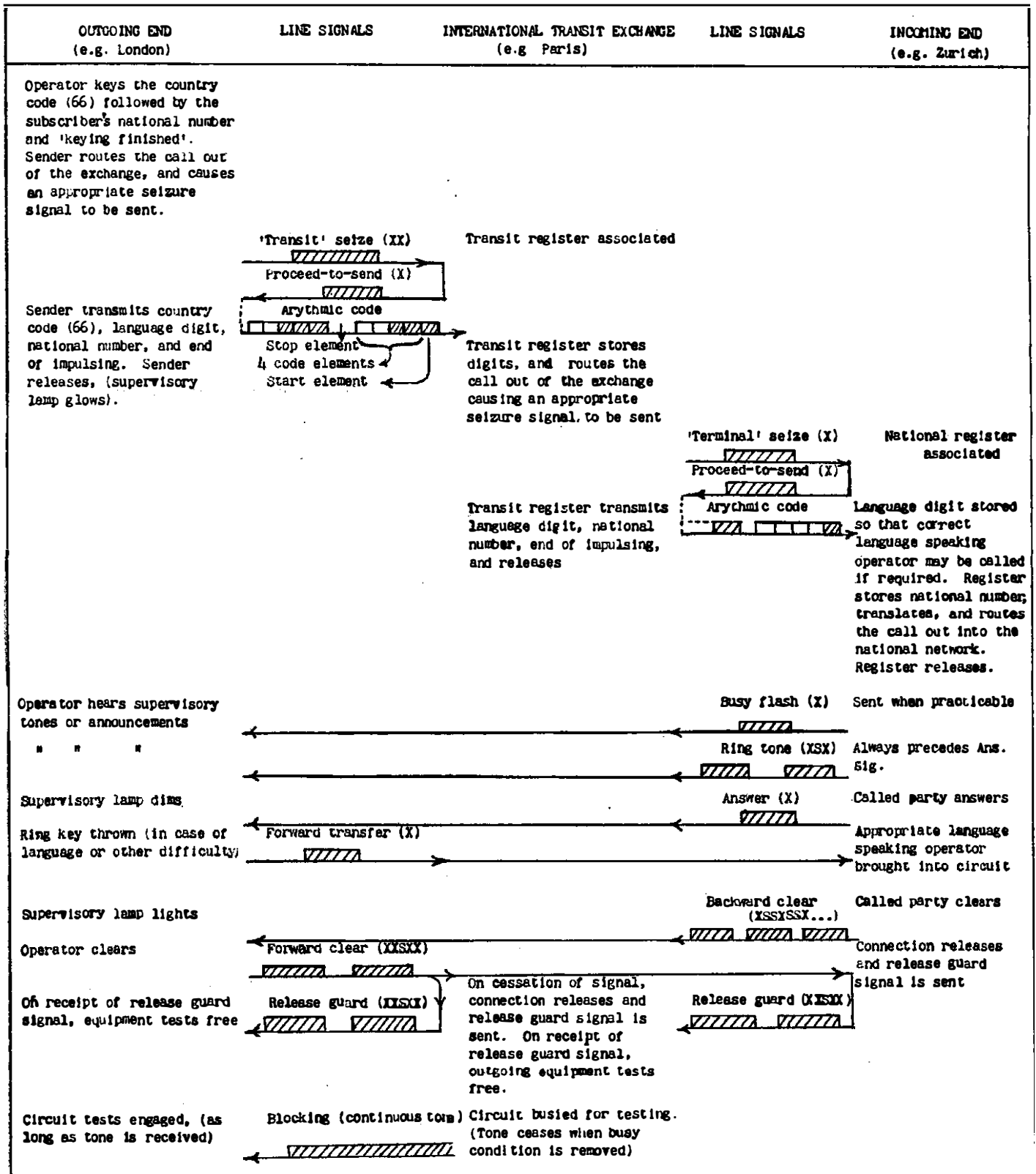

FIG. 5.—APPLICATION OF THE SIGNAL CODE—I V.F. SYSTEM.

control of the setting up of the connection to the extent that it sends only the code digits of the country of destination to each transit exchange in turn on receipt of its transit proceed-to-send signal. When the connection is established so far as to reach the incoming international terminal exchange, a different type of proceed-to-send signal is returned which indicates to the outgoing terminal register that the national number may now be sent. Thus, it will

be seen that an exchange returns a transit proceed-to-send signal if it receives a transit seizing signal, and a terminal proceed-to-send signal if it receives a terminal seizing signal.

All the operations and international signals, as they occur for the establishment of two-link transit connections with each signalling system, are shown diagrammatically in Figs. 4 and 5.

Control of the Registers.

When their functional control of route selection and digit sending is completed, the registers must release and allow speech conditions to be established. It follows that the outgoing register must know when its function has been completed, and since all European national numbers will not comprise a similar number of digits—those of the field trial countries possess a varying total not exceeding 10—it is necessary for the operator to send a signal indicating to the outgoing register that all the numerical information has been keyed. This signal, which may be keyed directly or obtained indirectly by the action of restoring the keyset connecting key, informs the outgoing registers not to expect any further digital signals and enables them, by counting, to determine when their sending function is completed. Before releasing, the outgoing register converts the "keying finished" signal and sends it forward in V.F. form as the "end-of-impulsing" signal to indicate to the incoming terminal register, and the transit register in the case of the single frequency system, that no more digits are to follow. The 2 V.F. transit registers regularly receive only the two digits of the code of the wanted country and, therefore, do not need to receive an end-of-impulsing signal.

No physical reason prevents the registers in either system from being arranged to commence their function before they receive the keying finished or end-of-impulsing signal. Although there are possible advantages in this arrangement for incoming registers, it is preferable, to avoid taking the international circuits and common apparatus into use unnecessarily on abandoned calls, that the originating registers should not commence their routing or digit sending function until keying is completed. Under full automatic working, i.e. subscriber-to-subscriber dialling, it may not be practicable to provide the outgoing register with a signal from subscribers' dials to indicate that all the digits have been dialled. An alternative method, which might be adopted, is to arrange for a signal to be returned from the incoming country to indicate when selection has been completed. The outgoing register having received this signal would know that all the necessary digits had been sent and it could then release. Provision for such a signal has been made in the 2V.F. signalling code and is termed the "end-of-selection" signal. Although the end-of-selection signal is not essential under semi-automatic operation it has other useful applications. It may be used to provide a supervisory lamp signal to the outgoing operator to indicate the state of the call in the absence of an international ring tone signal which, as explained later, may not always be returned from the incoming country. It may also be used to bring about the establishment of speech conditions at the outgoing terminal exchange. Where such a signal cannot be obtained from the national network it can be produced artificially when the incoming terminal register releases after having completed its function.

Language Discrimination.

The language to be used between operators is that agreed upon between Administrations for the particular route. It follows that an Administration may have a number of circuit groups coming from different countries on which different service languages are used. Since the origin of the traffic is not always known, e.g. the call may have been routed via an international transit exchange, some means must be provided to indicate the service language to be spoken by the operator answering the call. To provide this facility it has been arranged that an extra digit indicating the service language shall be sent on all connections. This language digit can be determined automatically by the outgoing register from an analysis of the wanted-country code or from the identity of the circuit concerned if the international

circuit is directly accessible from the manual board multiple. In London, where only two service languages are used, i.e. English and French, the language to be spoken by the incoming operator is indicated by the lighting of one of two calling lamps as determined by the language digit. On calls which are switched automatically at the incoming international terminal exchange, the language digit is stored, and used as described above if an assistance operator is called into circuit by means of the "forward transfer" signal.

The Problem of Service Tones.

When the transmission circuit is completed after the registers are released, controlling operators will receive any audible tones such as "Ring tone," "Busy tone," etc., which may be originated on the international route or in the incoming country to indicate the result of the selection. With the various types of national switching systems in use in Europe, however, the audible tones vary both in frequency and in cadence, and it is not unlikely that controlling operators may fail to recognise a proportion of the tones they will receive under semi-automatic working conditions. In an attempt to find a solution to this difficulty the C.C.I.F. has recommended the use of international signals for the "Ring tone" and "Busy flash" conditions. The intention is that ringing and busy conditions in the incoming country shall be detected at the incoming international terminal exchange and be made to initiate the transmission of the corresponding signal over the international line. At the outgoing international terminal exchange the receipt of either of these signals may be used to cause a corresponding supervisory lamp signal to be given to the outgoing international operator. Thus any operator who was in doubt as to the significance of a tone would be able to identify the tone by means of the lamp signal. It should be mentioned, however, that the conversion of national tones into international signals presents many problems, especially if the national tones vary both in frequency and level, and it may be that, initially at least, some countries will be unable to return the international tone signals. It has been agreed that, with the 2V.F. system, all countries which are unable to return international ring or busy tone signals will invariably return the end-of-selection signal.

Assistance Facility.

If the outgoing operator experiences language difficulties with the called subscriber or needs an explanation of the significance of a service tone or audible announcement she is able to bring about the intervention of an assistance operator on the line at the incoming international terminal exchange. This is effected by the operation of a key which causes a forward transfer signal to be sent, the receipt of which at the incoming international terminal exchange will call the attention of an operator by a flashing lamp signal.

The forward transfer signal may also be used for recalling the operator at the incoming international terminal exchange on calls which are routed via the manual board at this exchange.

Numbers used for calling Operators at the Incoming International Terminal Exchange.

To set up a call to a group of incoming operators at the incoming international terminal exchange, the following information will be keyed in the order stated below:—

- (a) International code of the country of destination (may be omitted where access to the circuit used is obtained direct from the multiple jack).
- (b) The language digit, if not sent automatically by the outgoing register.
- (c) The operator code, Code "11" of the binary series of digits.
- (d) The end-of-keying signal.

To call a particular operator at the incoming international terminal exchange, a similar procedure to that described above will be followed with the exception that Code "12" and the required operator's position number will be keyed instead of Code "11."

Access to a particular group of operators can also be obtained by using Code "12" followed by digits assigned and agreed upon by the relative Administrations to route the call to the appropriate group of positions.

Alternative Routing—Route Indication.

With automatic alternative routing the outgoing operator will not normally be aware of the actual route taken on any particular call and it may be desirable for accounting purposes, i.e. the apportionment of call revenue amongst the countries the call traverses, to determine the route taken and display this information to the operator so that it can be entered on the call ticket.

It would be possible in both signalling systems to arrange for the outgoing register to pass a signal to the operator indicating whether the first, second or third choice outgoing route had been taken, and this information, if considered in conjunction with the country code keyed by the operator, could be used to determine the actual route taken. Where, however, alternative routing is used at a transit switching centre, further information is required by the outgoing register to indicate the actual route taken from the transit exchange towards the country of destination. A ready means of providing this information exists in the 2V.F. system because, with this system, the outgoing register retains full control of the routing up to the incoming international terminal exchange and receives a transit proceed-to-send signal inviting the country code each time the call reaches a transit switching centre. Thus, if only one transit proceed-to-send signal is received by the outgoing register it may be assumed that a direct route between the transit exchange and the incoming international terminal exchange was used. If two transit proceed-to-send signals are received, then the call must have taken an indirect route from the first transit switching centre. In the London field trial equipment the choice of outgoing route and the number of transit proceed-to-send signals received is displayed on a panel of lamps. A subsequent reference to a record of the physical routings gives the identity of the actual route taken.

Supervision of the Called Party.

The controlling operator at the outgoing international terminal exchange will obtain direct supervision of the called subscriber's switch-hook on calls completed automatically at the incoming international terminal exchange. On calls routed via an operator at the incoming international terminal exchange, such direct supervision will be obtained only where through-signalling facilities are provided on the incoming "B" positions. Where these facilities have been provided the controlling operator will obtain a supervisory lamp signal when the incoming operator answers the call and a clearing signal when this operator goes out of circuit. She will subsequently obtain supervisory lamp signals when the called party answers and clears. These supervisory facilities are available in both signalling systems, but in the case of the single frequency system, where the backward clearing signal comprises a continuous succession of pulses, arrangements must be made to remove the backward clearing signal before speech conditions can be established on re-answer.

Route Congestion at Transit Switching Centres.

When setting up connections under international automatic alternative routing conditions, the controlling operators can receive no indication if congestion is encountered until the registers have tested all available routes. This applies similarly in both systems and if all circuits from the outgoing terminal exchange are busy, the terminal register releases and the operator receives her own national "busy" indication. If route congestion occurs at an international transit exchange, however, a verbal announcement giving the name of the town concerned is heard by the originating operator. In the 2V.F. system the outgoing terminal register is awaiting a proceed-to-send signal at this stage and needs the receipt of a signal to bring about its release and establish the speech path. The Busy signal (CX) is used for this purpose, being transmitted from the transit exchange when the transit register releases on finding the outgoing circuits busy, and with the release of the registers the controlling operator receives any audible indication given from the transit exchange. The receipt of the Busy signal in conjunction with the route indicator provides the opportunity, if desired, to give the controlling operator a visual indication of the point at which the congestion occurs and, during the field trials, connection to verbal announcement and to the Busy tone of the country concerned are to be tried out as alternative arrangements in the 2V.F. system.

CONCLUSION

It has not been possible within the space available to do more than outline the principal facilities required for an international semi-automatic signalling system and to indicate the basis on which the field trial equipment has been designed. The equipment for the London centre, which contains many unique features, including provisions for detecting signalling failures automatically, has been developed in close co-operation between the British Post Office and its telephone manufacturers through the machinery of the British Telephone Technical Development Committee. Auxiliary test equipment,⁵ designed and constructed by the Telephone Branch of the Post Office, E.-in-C.'s Office, is also provided for checking the timing and identity of the voice-frequency signals. Close attention has been given by the C.C.I.F. to the general organisation for the conduct of the trials⁶ including the determination of the operating methods to be employed, the preparation of standard forms for recording observation results and the collection of statistical information.⁷ In addition it has been necessary to formulate a new procedure for the maintenance of the international semi-automatic circuits, including a general broad classification of faults on a functional basis, thus permitting an analysis of faults to be made irrespective of the type of equipment employed.⁸

ACKNOWLEDGMENTS

The author desires to express his thanks to colleagues in the Signalling Facilities Group of the Telephone Branch for the very helpful comments and advice received during the preparation of this article.

⁵ See page 165 of this issue.

⁶ C.C.I.F.—C.E.A. Document No. 14. Conduct of the Trials.

⁷ C.C.I.F.—C.E.A. Document No. 11. Instructions for operators in the Field Trial Network.

⁸ C.C.I.F.—C.E.A. Document No. 13. Maintenance Instructions.

Test Equipment for the London Centre of the C.C.I.F. Field Trials of International Semi-Automatic Telephone Operation

A. W. BATES, A.M.I.E.E.†

U.D.C. 621.395.35: 621.395.364: 621.317.34

This article describes test equipment designed for use on the international semi-automatic field trials, which enables sent or received V.F. signal sequences on any circuit to be observed and a check made that the signals fall within prescribed limits. The main equipment, known as a Call Progress Indicator, incorporates electronic timing circuits for measuring the lengths of the V.F. signals, this information being automatically displayed by lamps. Other test equipments enable traffic observations to be made on outgoing calls and give facilities whereby engineering officers can check the signals on incoming calls.

INTRODUCTION

WITH the object of economising in costly line plant by providing a more rapid service, semi-automatic working has been introduced experimentally on a number of international circuits previously controlled on a generator-signalling basis. A description of two systems, which conform to C.C.I.F. signalling recommendations, has been the subject of an article in this Journal,¹ and an experimental installation of 2 V.F. and 1 V.F. signalling equipment has now been completed to obtain information on numerous administrative and engineering problems, and to help in assessing the merits of the two signalling systems.

Before electrical signalling methods were applied to communications, ingenious attempts were made from time to time to provide rapid transmission of information between widely separated places, but delays and difficulties in deciphering the signals set a limit to the distance over which an intelligible message could be directly received. To extend this limit without impairing intelligibility has been the constant aim of communication engineers, and electrical development has been so great in recent years that it is now possible to signal over any distance with negligible error, the limiting factor being principally that of cost. With the extension of automatic principles to international telephone communication, greater expenditure on the reduction of signal distortion, which is a major cause of error, is justified by the high cost of international circuits. Signal distortion can now be specified to close limits which are both practically and economically attainable, the closeness of the limits depending to a great extent on the means available for testing and correcting the performance of the signalling equipment. The maintenance aids described in this article were developed for achieving the necessary standard of accuracy by monitoring and measuring the many signals concerned.

OBJECTIVES AND METHODS ADOPTED

The function of a V.F. signalling system, when used for semi-automatic telephone operation, is to convert the D.C. conditions, which arise as a result of the actions of the operator originating a call or a person answering a call, into voice frequency signals for transmission to the distant end of a circuit where they are detected and converted back to the appropriate D.C. conditions. It follows, therefore, that a reliable indication of the functioning of the signalling equipment, and indeed the progress of the call to its destination, can be obtained by observing the succession of V.F. signals sent or received over a line.

To ensure that the signals are recognised correctly at the distant end of a line, they must possess well-defined characteristics, particularly with regard to frequency, level and duration, and, therefore, any equipment which is designed to observe line signals should be capable of check-

ing not only the correct sequence of signals but also their essential characteristics. Such an equipment would have an added value if it could be made to indicate whether the durations of the signals were within certain defined limits, since the knowledge that the length of a signal was close to the permitted limit might enable the testing officer to anticipate the development of a fault and take action to prevent it.

Testing and Engineering Observation Equipment.

Equipment which fulfils the requirements already outlined has been developed for the international semi-automatic field trials, enabling the signalling sequences on any selected circuit to be observed and, on call failure, indicating the stage at which failure occurred. The control panel on which the signalling sequences are indicated has become known as the Call Progress Indicator and is mounted on the trunk test rack to be readily available to the testing officer. Two Call Progress Indicators have been provided at the London Centre, one for use with the 2 V.F. signalling system and the other with the 1 V.F. signalling system.

The usual procedure for testing the signalling performance of automatic equipment is to apply signals of a known length approaching the limits of the specified duration and by this means it is possible to ascertain the state of the adjustment of the automatic equipment. In Great Britain this facility is usually incorporated in the routiners or testers used for checking the performance of the various items of equipment, but since it is doubtful whether, owing to the small amount of equipment involved, testers will become available generally throughout the European Field Trials Network, it was considered advisable to develop a signal generator capable of generating any signal or sequence of signals, including numerical signals in the form of test numbers.

Transmission Testing.

With manual working, periodic speech tests can be made on international lines from the multiple jacks at each end of a circuit, but this facility may no longer be available with automatic working, where the two ends of a circuit may terminate on switches. The need, therefore, arises for a means of testing the transmission conditions of international lines, preferably without co-operation at the distant end of the circuit. In addition, the desirability of reducing the time during which international circuits are taken out of service, owing to faults or maintenance attention, justifies the use of automatic transmission testing methods, and two such methods have been recommended by the C.C.I.F. for trial.

The first method consists of looping the "go" and "return" channels at the incoming end of an international circuit in the idle condition so that a test signal applied to the "go" channel at the outgoing end can be measured on the "return" channel at the same end. The disconnection of

† Assistant Engineer, Telephone Development and Maintenance Branch, E.-in-C.'s Office.

¹ *P.O.E.E.J.*, Vol. 45, p. 120.

the loop at the incoming end will take place on receipt of a seizure signal. Certain precautions must be taken with this method of testing to ensure that any part of the seizure signal which passes round the loop and is returned to the outgoing end before the loop can be cut is not recognised as a signal at the outgoing end. The limitations of this method are that only the four-wire part of the circuit can be tested and that the "go" and "return" channels cannot be tested separately. It has, however, proved very useful for the broad localisation of faults, such as distinguishing line faults from exchange faults, and for routine transmission testing.

The second method consists of the provision of an automatic transmission measuring device at the incoming exchange, to which access is obtained by keying a special code over the circuit under test. A signal is returned to the outgoing exchange when connection to the measuring device at the incoming exchange has been effected and this causes a test signal of 800 c/s at 0 db. to be sent over the circuit under test for measuring by the receiving device at the incoming exchange. If the level of the test signal thus measured at the incoming exchange is within the prescribed limits, a confirmatory 800 c/s test signal at 0 db. is returned and measured automatically at the outgoing end. If the level of the test signal received by the incoming exchange is outside the prescribed limits or is not received, a special signal is returned, indicating that the "go" direction of transmission is unsatisfactory.

The advantage of this method is that each direction of transmission can be tested separately between the two-wire ends of a circuit, but this advantage is lost when a "go" direction transmission fault is sufficiently severe to prevent the setting-up signal from preparing the measuring equipment.

Service Observation Equipment.

To obtain a comprehensive picture of the quality of service provided by the semi-automatic international equipment, service observations are required at the outgoing international exchange on such conditions as the accuracy of operators' keying, the speed of setting up calls and the occurrence of service difficulties. It is also desirable to observe the progress of the call at the point of entry into the incoming national network at the international terminal exchange, so that the proportion of failures due to the national and international equipments may be separately assessed.

To provide such information, two different types of equipment have been developed. The outgoing observation equipment is arranged to display the digits keyed by the operator and to record the supervisory and route-indicating signals received on the circuit under observation. The incoming observation equipment, which is transportable and designed for use in the apparatus room, displays all the numerical digits pulsed into the national network from the incoming register.

LIST OF SIGNALS

The signals used in the two international systems are shown in Tables 1-4, so that the subsequent details of the facilities provided by the Call Progress Indicators may be more readily appreciated.

2 V.F. Signals.

Line signals, which are of single- or double-element form, are shown in Table 1. The numerical digits and certain inter-register signals are sent in the form of four-element combinations of X or Y frequencies, their arrangement being in binary order, as shown in Table 2.

TABLE 1
2 V.F. Signals, Except Binary Code Signals

Forward Direction		Backward Direction	
Function	Signal elements	Function	Signal elements
Terminal seizure	CX	Terminal proceed to send	X
Transit seizure	CY	Transit proceed to send	Y
Forward transfer	PXX*	Terminal acknowledgment of digits	} See Table 2
Forward clear	PYY*	Transit acknowledgment of digits	
		End of selection	C
		Busy flash	CX
		Ring tone	CY
		Answer	PY
		Backward clear	PX
		Release guard	PYY*
		Blocking	PX

EXPLANATION:

Symbol	Frequency	Description	Nominal Length (mS)	Sending Tolerance (mS)
C	2,040 + 2,400 c/s "compound"	Short prefix	50	± 10
P	ditto	Long prefix	160	± 40
X Y	2,040 c/s } 2,400 c/s }	Short suffix	80	± 20
XX* YY*	2,040 c/s } 2,400 c/s }	Long suffix	300	± 60

* In the case of long suffixes only, it should be noted that XX or YY is a symbol for a continuous long pulse of tone, and not two pulses separated by an interval.

TABLE 2
2 V.F. Binary Code Signals

Function	Signal Code*	Notes
Digit 1	YYXX	Receipt of every four-element binary digit is acknowledged in the return direction by:— X for terminal acknowledgment Y for transit acknowledgment
Digit 2	YYXY	
Digit 3	YXXY	
Digit 4	YXYY	
Digit 5	YXYX	
Digit 6	YXXY	
Digit 7	YXXX	
Digit 8	XYYY	
Digit 9	XYYX	
Digit 0	XYXY	
Call to operator (Code 11)	XYXX	11th binary combination
Call to particular operator (Code 12)
	XXYY	12th binary combination
	XXYX	} 13th and 14th binary combinations not used
	XXXY	
End of impulsing
	XXXX	15th binary combination
	YYYY	16th binary combination not used

EXPLANATION:

Symbol	Frequency	Nominal Length (mS)	Sending Tolerance (mS)
X	2,040 c/s	25	± 5
Y	2,400 c/s	25	± 5

* In the binary signal code combinations, each element is separated from the next by a space of 25 ± 5 mS. The function of each X element is to step the receiving distributor and also to operate a storage relay having the numerical significance of 8, 4, 2 and 1 in the four columns respectively. Each Y element steps the distributor without storing a digit. Thus, for example, code YXXY represents 0 + 4 + 2 + 0 = 6.

1 V.F. Signals.

Line signals, which with the exception of "backward clear" are of single- or triple-element form, are shown in Table 3. The numerical digits and certain inter-register signals are sent in the form of six-element combinations of tone and space periods. In each combination, the first and last elements, which are tone and space respectively, provide the start-stop feature familiar in telegraph practice. Start-stop working is necessary in the international 1 V.F. case, as in telegraph signalling, because the receiving equipment cannot respond if the first element in a signal is a space, as this is no change from the idle condition. In telegraph working, though not in the international systems, digits may follow each other at irregular or arhythmic intervals, an arhythmic code thus becoming synonymous with a start-stop code.

TABLE 3
1 V.F. Signals, Except Arhythmic Code Signals

Forward Direction		Backward Direction	
Function	Signal Code	Function	Signal Code
Terminal seizure	X	Proceed to send	X
Transit seizure	XX*	Busy flash	X
Forward transfer	X	Ring tone	XSX
Forward clear	XXSXX*	Answer	X
		Backward clear	XSSXSSX*.... (continuous)
		Release guard	XXSXX*
		Blocking	Permanent signal

EXPLANATION:

Symbol	Frequency	Description	Nominal Length (mS)	Sending Tolerance (mS)
X	2,280 c/s	Short tone element	100	± 20
XX*	2,280 c/s	Long tone element	625	± 125
S	Silent interval	Short space element	100	± 20
SS*	Silent interval	Long space element	300	± 50

* In the case of long elements, it should be noted that XX or SS is a symbol for a single continuous element.

TABLE 4
1 V.F. Arhythmic Code Signals

Function	Signal Code	Notes
Digit 1	XSSXXS	
Digit 2	XSXSXS	
Digit 3	XSXSSS	In every code, the first element (X) is the "start" element, and the last (S) is the "stop" element.
Digit 4	XXSSXS	
Digit 5	XXSSSS	
Digit 6	XXXSSS	
Digit 7	XSSXSX	
Digit 8	XSSXSX	
Digit 9	XSSXSX	
Digit 0	XXSSSS	
Call to operator (code 11)	XXXXSS	11th combination
Call to particular operator (code 12)	XXXSXS	12th combination
	XXSXSX	13th combination not used
	XSSXSX	14th combination not used
End of impulsing	XXXXXS	15th combination
	XSSSSS	16th combination not used

EXPLANATION:

Symbol	Frequency	Nominal Length (mS)	Sending Tolerance (mS)
X	2,280 c/s	50	± 10
S	Silent interval	50	± 10

CALL PROGRESS INDICATOR

Facilities Provided.

Both the 2 V.F. and 1 V.F. Call Progress Indicators, which in function and appearance resemble each other closely, provide the following facilities:—

- Measurement of line signals.
- Tolerance indication.
- Decoding and display of line signals.
- Measurement of numerical digits.
- Display of numerical digits.
- Cancellation of display by succeeding signals.
- Voice immunity.
- Manual control for fault tracing.
- Use as general-purpose millisecond-meter (2 V.F. equipment only).

The facilities are discussed in the following paragraphs.

Measurement of Line Signals.—In signalling systems which use signal elements whose only distinguishing features are differences in length, the need for accuracy in both sending and detecting these lengths is clearly important. The mechanical and electrical characteristics of the equipment through which the signals pass, from their generation to their detection, may cause unavoidable distortion of signal element length, and, although signalling circuits are designed to work reliably so long as these distortions are small, an ample margin of safety between long and short elements must be maintained if trouble-free operation is to be assured.

To enable a close check to be kept on the lengths of all signals sent or received, each Call Progress Indicator has two identical timing circuits, operating from a 1,000 c/s source, which in the 2 V.F. case are used to measure prefix and suffix elements respectively. In the 1 V.F. case, where some signals consist of three elements (see Table 3), conditions are less straightforward. One timing circuit is used to measure the first signal element, and the result is rapidly transferred to a relay storage group during the space element, which is measured by the second timing circuit. The first timing circuit is then released in time to measure the third signal element, should one arrive. As the indicator cannot foretell whether a signal will be of one- or three-element form, it is prevented from decoding a signal or accepting a new one until either a third signal element has arrived within a certain time limit, or a maximum space element timing period has elapsed.

Timing is started automatically as each signal arrives, and the length of each element in milliseconds appears on a lamp display when the signal ends.

Tolerance Indication.—As it is easier, at a quick glance, to recognise the colour of one lamp than to appreciate the numerical significance of several, the test clerk is relieved from the necessity of reading the exact length of each signal in milliseconds by the tolerance indication display, which appears simultaneously with the millisecond display. If the measured elements are within the tolerances listed in Tables 1 and 3, a green lamp is lit; if too long or too short, other colours are used and an alarm is given.

Decoding and Display of Line Signals.—All V.F. signals transmitted on the "go" or "return" pairs of any selected international circuit are decoded and displayed so that the test clerk has an immediate indication of the stage reached during the progress of the call.

Measurement of Numerical Digits.—Since at least eight numerical digits may be expected on international calls, the number of constituent elements in the 2 V.F. case could be 32 or more. The cost and complication of providing apparatus to display the measured length of each element would be out of all proportion to the value of the result, particularly as it is relatively unimportant in the 2 V.F. system if the numerical signal elements are longer than

nominal. It was therefore decided that, because the nominal lengths of the tone and space elements are the same, a simple and useful check would be obtained if all elements in a train of digits were compared alternately with two timing circuits, each set to the same minimum length, and one triggered by the start of a tone element and the other by the start of the following space element. By this means, an indication and alarm are given if any element finishes in less than the minimum period.

The 1 V.F. arhythmic numerical code (Table 4) differs from the 2 V.F. binary code (Table 2) in that tone and space elements follow alternately in the binary code, but tone elements (or space elements) may appear consecutively in the arhythmic code. The previously described method of measuring the 2 V.F. elements is thus not suitable for the 1 V.F. case, since comparison of the 1 V.F. elements with a fixed minimum reference length is not possible. Instead, a test is made in the following manner to determine whether the instants at which the numerical elements change from tone to space, or space to tone, occur during the regularly recurring time-limits of 40-60 mS, 90-110 mS (etc.) after the commencement of the start element. An alarm circuit for detecting the operation or release of a relay contact is connected to the V.F. receiver contact which responds to the numerical elements. Also, the arrival of each start element triggers a timing circuit which generates, until cut off by the succeeding stop element, a train of pulses for making the alarm circuit inoperative for periods of 20 mS in every 50. In this way, numerical elements arriving at true nominal speed move the impulsing contact from its space to its tone position, or vice versa, in the centre of each "alarm disconnected" period, i.e. every 50th mS, as illustrated in Fig. 1, and no alarm results. If, however, the

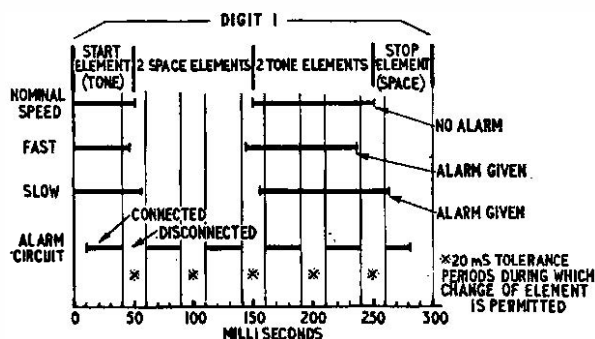

FIG. 1.—SPEED-CHECKING ARRANGEMENT FOR 1 V.F. ARYTHMIC CODE SIGNALS.

incoming elements are faster or slower than nominal, the time-displacement between them and the generated reference pulses becomes cumulative, and eventually, if the out-of-synchronism or distortion exceeds the ± 10 mS tolerance, the impulsing contact moves while the alarm is connected, and an alarm is given.

Display and Cancellation of Numerical Digits.—All numerical digits received or sent in V.F. pulse form are decoded, stored on relays and displayed as illuminated figures on a ground-glass screen.

To save the test clerk from continuous manual operation of the Call Progress Indicator, the measurement and decoding lamps remain lit only until a new signal arrives, when they are extinguished automatically and the new signal is displayed. Signals are unlikely to follow each other so closely as to make displays unreadable, but to prevent this possibility a key is provided by which the test clerk can prevent the indicator from accepting any new signals should he desire to study a display without interruption. If

required, the release guard signal will automatically reset the whole indicator on completion of a call, and thus provide continuous monitoring.

Voice Immunity.—As the V.F. signal receivers which respond to forward and backward signals are connected continuously across the "go" and "return" pairs of the line under observation, an occasional false operation of short duration, due to speech, is difficult to avoid. It is therefore necessary, when speech conditions are established, to disconnect the circuit which responds to short signals, e.g. numerical and acknowledgment signals, and reconnect the normal line signal decoding circuit.

Manual Control for Fault Tracing.—If a fault develops on the Call Progress Indicator, fault localisation is made easier if the electronic timing circuits and pulse counting relays are operated at a speed which can be followed by eye. By using keys mounted near the circuits concerned, the 1,000 c/s supply is disconnected and pulses can be generated manually as slowly as required so that the behaviour of various stages of equipment may be observed. Small neon tubes in each of the binary counting stages indicate visually the number of pulses that have been stored.

Use as General-Purpose Millisecond-Meter.—The electronic timing circuits are suitable for measuring pulses from external sources, such as the operate or release lags of relays, so a key has been provided to switch the timing circuits to input terminals on the rack, and to disconnect all the Call Progress Indicator equipment except the timing display lamps, and their controlling relays.

Design Principles.

The block schematic diagrams (Figs. 2 and 3) illustrate the general similarity between the 2 V.F. and 1 V.F. Call Progress Indicators. In either case, V.F. receivers are connected in parallel with the "go" and "return" pairs of an international circuit by the insertion of two plugs into monitoring jacks on the test desk. One receiver controls the signal-measuring and decoding circuits, while the other controls a decoding circuit only, so that by appropriately inserting the plugs the test clerk can measure either forward or backward signals, but can decode all signals.

The electronic timing circuit uses the principle of counting the number of regularly recurring pulses of known length

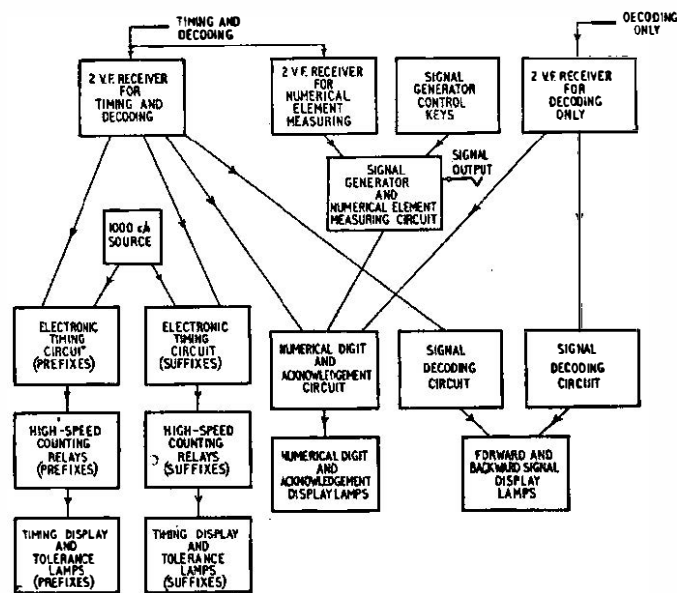

FIG. 2.—BLOCK SCHEMATIC DIAGRAM OF 2 V.F. CALL PROGRESS INDICATOR.

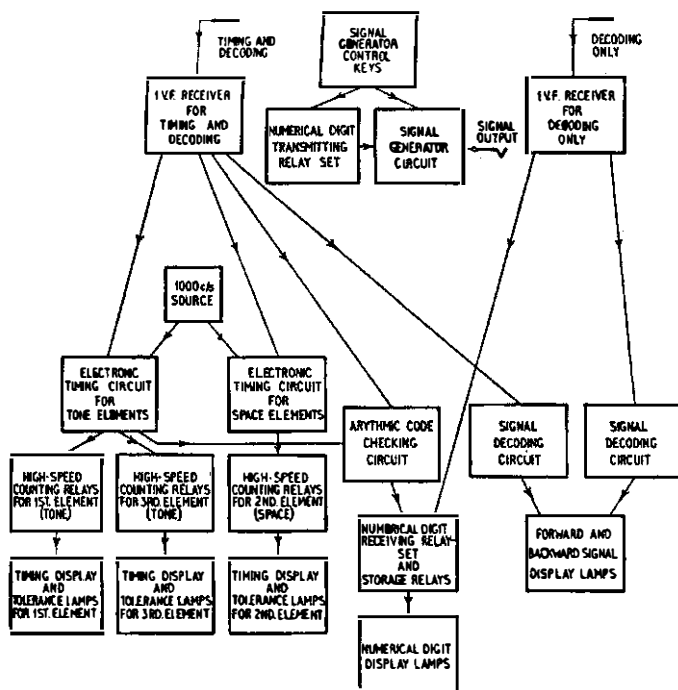

FIG. 3.—BLOCK SCHEMATIC DIAGRAM OF 1 V.F. CALL PROGRESS INDICATOR.

generated by a free-running oscillator between the instants at which the signal to be measured starts and ends. In deciding on a suitable oscillator frequency, the degree of precision required in the signal measurement has had to be weighed against the difficulty of counting the pulses, and a

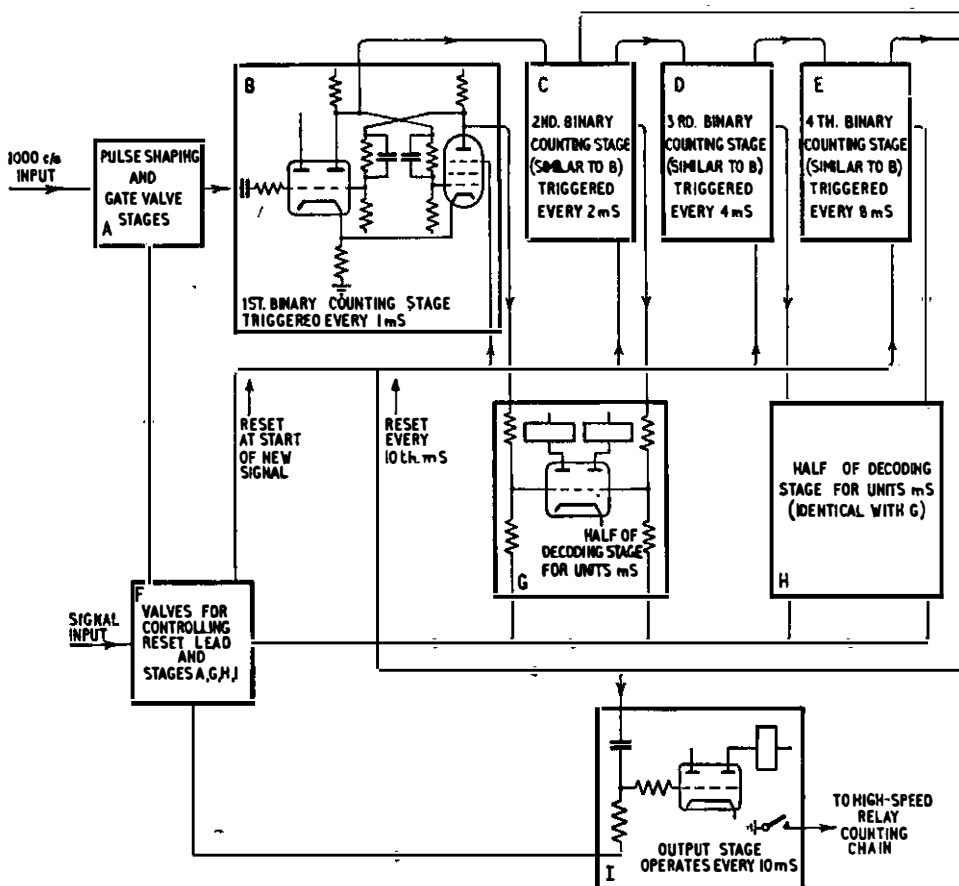

FIG. 4.—SIMPLIFIED BLOCK SCHEMATIC DIAGRAM OF ELECTRONIC TIMING CIRCUIT FOR MEASURING 1 V.F. AND 2 V.F. SIGNALS.

1,000 c/s source, with an absolute accuracy of better than one part in a million, has been chosen so that measurements can be made to the nearest millisecond. The arrival of a signal to be measured causes a gate valve to pass a pulse every millisecond from the oscillator to four pairs of counting valves arranged in binary order (Blocks B, C, D, E in Fig. 4). One valve of each pair is normally conducting and the other not conducting, and a change in the conducting conditions occurs with the registration of every 1-mS pulse by the first pair; with every second 1-mS pulse by the second pair; with every fourth 1-mS pulse by the third pair; and with every eighth 1-mS pulse by the fourth pair. As long as the signal persists, the valves continue to count the 1-mS pulses, restoring to normal after every tenth pulse, then starting afresh. When the valves restore at every tenth millisecond, a pulse is passed to a high-speed relay counting chain capable of storing nine such pulses. At every hundredth millisecond, the high-speed chain restores and passes a pulse to a group of 3,000-type relays, so that signal measurements in hundreds and tens of milliseconds are stored on relays. The units milliseconds are stored on valves and are transferred by relays to the display when the signal ends.

To reduce the amount of maintenance required, uniselectors have been sparingly used. Three are necessary as numerical digit and acknowledgment signal distributors on the 2 V.F. equipment, where provision is made for receiving, decoding and storing a maximum of 60 numerical elements at 50 mS intervals (i.e. 15 digits). The 1 V.F. equipment requires only two uniselectors, in the digit distribution and arithmetic code checking circuits.

When locating faults on the international equipment, the test clerk occasionally requires V.F. signals for testing various circuit functions. It would be unsatisfactory to rely

on incoming signals for this purpose, so both 2 V.F. and 1 V.F. signal generators have been provided on the Call Progress Indicator racks, with their control panels mounted on the trunk test racks. By this means, the test clerk has all line signals and some trains of numerical signals immediately available, and if specially stringent tests are required, the length of the signals can be easily altered at the control panel and measured on the Call Progress Indicator timing equipment before being put to use.

The 2 V.F. and 1 V.F. signal generators are similar and each consists of two interconnected valve timing circuits whose time-constants can be adjusted by remotely situated potentiometers. The main difference is that, whereas the 2 V.F. circuit has to produce either one or two elements (prefix and suffix), the 1 V.F. generator timing circuit which produces the tone elements may have to be used twice in rapid succession if the signal is of the "tone-space-tone" variety.

A mains-driven power unit is mounted on the rack to provide 6.3 V A.C. and stabilised +100 V

and -100 V D.C. for the timing circuits and signal generator. Voltage regulation is achieved by an arrangement of the hot-valve series-pentode type.

Points of Circuit Interest.

Because of the large number of 1-mS pulses which have to be counted during signal measurement, the chains of relays for counting the tens and hundreds of milliseconds are necessarily long, but the circuits have been designed to economise in relays wherever possible. For example, 18 high-speed relays in nine two-step pairs for counting the "tens of milliseconds" pulses, as mentioned in the previous sub-section, have been reduced to ten relays by using only four two-step pairs with another common pair for pulse-dividing (see Fig. 5). In this way, the

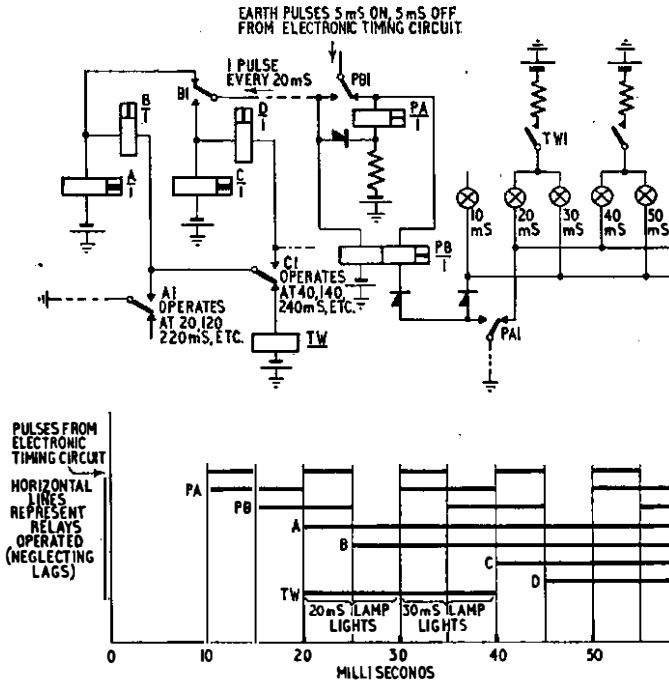
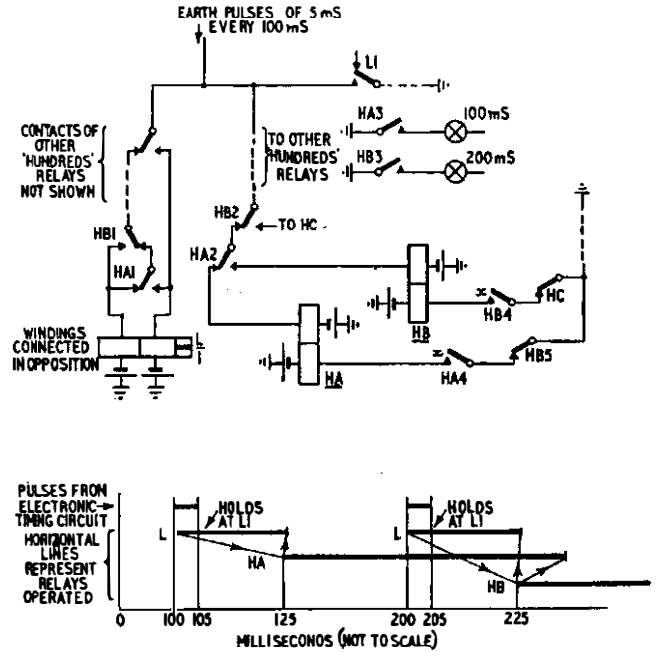

FIG. 5.—METHOD OF LIGHTING "TENS OF MILLISECONDS" LAMPS, SHOWING PULSE-DIVIDER RELAYS PA, PB, AND TWO PAIRS OF COUNTING RELAYS.

condition of the two-step pairs indicates the signal length to the nearest 20 mS, which is subdivided by the pulse-divider relays to the nearest 10 mS.

When the 1 V.F. "hundreds of milliseconds" counting circuit was being designed, the original intention was to use the same circuit as in the 2 V.F. case, but the 1 V.F. equipment requires three counting chains, all longer than the two used in the 2 V.F. equipment. The circuit was, therefore, changed, with the result that 35 less relays were required, and a simple method of operating 3,000-type relays, with an operate lag of 25 mS approximately, from short pulses of about 5 mS was introduced. In the 2 V.F. case, high-speed relays arranged in two-step pairs were used with 3,000-type relief relays, partly to keep the "tens" and "hundreds of milliseconds" counting circuits identical, but chiefly because the operating pulses, although occurring at 100-mS intervals, were too short to operate 3,000-type relays directly. This relay arrangement did not appear unduly complicated when originally designed because only two groups (for prefixes and suffixes) were needed, and neither exceeded four stages (400 mS); but for 1 V.F. signals, consisting of three elements of which two could reach 700 mS, the number of relays for counting the "hundreds of milliseconds" alone would have totalled 56. With the circuit, shown in Fig. 6, for counting



Note.—An arrow points to the relay which is energised or de-energised by the operation or release of the relay from which the arrow starts.

FIG. 6.—METHOD OF LIGHTING 1 V.F. "HUNDREDS OF MILLISECONDS" LAMPS.

the "hundreds of milliseconds" pulses (of 5 mS duration every 100 mS), a common high-speed relay operates on each pulse, then locks to maintain an operating path for a chain of 3,000-type relays until full operation of the first of these releases the high-speed relay. Flux reversal in the high-speed relay ensures its release if it has not already done so during the transit time of the 3,000-type relay changeover contact. Three "hundreds of milliseconds" counting chains using this circuit require only 21 relays for counting seven, four and seven pulses respectively.

OUTGOING OBSERVATION EQUIPMENT

This equipment (Fig. 7), which works on the exchange 50 V negative and positive supplies, has been mounted on a rack in the switchroom in which the international semi-automatic calls are handled, and for that reason has been made noiseless in operation by use of relays and valves. It provides operating information, on a lamp display, to an observation operator at a switchboard position adjacent to, and sharing the same multiple as, the regular operating positions. The following facilities are provided:—

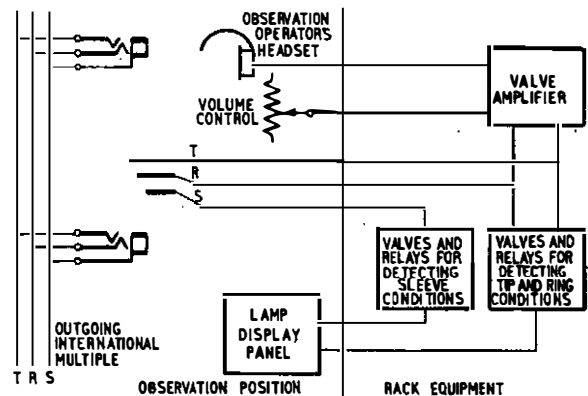

FIG. 7.—BLOCK SCHEMATIC DIAGRAM OF OUTGOING OBSERVATION EQUIPMENT.

International circuit free or busy indication.
Reproduction of originating operator's calling supervisory lamp signal.
Indication of the numerical digits keyed by the operator.
Reproduction of the route indication display.
Listening circuit for monitoring the setting-up of the call and subsequent conversation.

The observation operator has a plug-ended cord for connecting the observation equipment to any outgoing international circuit in parallel with the cord circuit of the operator who is setting up the call. Two valves, biased to different potentials, are connected to the sleeve of the plug for detecting the "circuit free" and "calling supervisory" conditions respectively. Seven valves are connected to the tip and ring conductors for detecting the various combinations of light and heavy positive and negative potential which actuate the sender when the operator keys the international number. These valves also detect the potentials which are returned from the sender to operate the display which informs the operator of the route chosen by the automatic apparatus. An amplifier also is connected to the tip and ring wires so that the observation operator can listen on the circuit with negligible effect on line transmission, and by using a stop-watch, may obtain useful traffic data on international semi-automatic working at the originating point.

INCOMING OBSERVATION EQUIPMENT

This is a transportable equipment for use in the automatic apparatus room, and displays on a ground-glass screen the numerical digits pulsed out to the local network when an incoming international call is being established.

The facilities provided by this equipment, which also works on the exchange 50 V negative supply, are as follows:—

Detection of trains of "make" or "break" pulses by a valve-tapping circuit, without affecting impulsing conditions in any way.

Storage and display of the numerical digits thus detected.

Lamp indication when the called subscriber answers or clears.

Automatic cancellation of the display when a new incoming call is received.

The display and selector train can be held for fault-tracing if required.

A listening circuit is provided to enable the user to check that conversation has been satisfactorily established.

The display is arrested if an open trunk or reversal is encountered between the impulsing source and the first transmission bridge, thus materially assisting in localising such faults.

The equipment contains a valve circuit which responds to the changes of potential on the negative wire during impulsing between the incoming register and the selectors in the national network. The impulses thus detected are

distributed by 3,000-type relays to 600-type storage relays, which help to make the equipment compact. The required subscriber's number is pulsed out from the incoming register in the form of trains of make impulses, which are converted by an auto-to-auto relay set into break impulses for operating the local selectors. The observation equipment can if required be connected to either side of the relay set and will accept make or break impulses by operating a key appropriately; thus, observations can be taken either on a particular international line, or on a particular selector.

If it is required to check the output from some impulsing source not connected to an impulsing relay, a key may be operated to replace the valve circuit by a suitably terminated relay which responds directly to the loop/disconnect impulses.

CONCLUSIONS

Since the international equipment was brought into service, the 2 V.F. Call Progress Indicator has been used for long periods and its precision measurements have helped to trace several faults due to incorrect length of signal element, which otherwise might have proved difficult to locate.

As many facilities as possible have been provided but, to achieve reasonable circuit simplicity, several economies have been made, such as the provision of only sufficient equipment for measuring either forward or backward signals but not both at once. Also, in the 2 V.F. case, a substantial saving of equipment was possible by not measuring the numerical acknowledgment signals, whose maximum length is relatively unimportant, and which, if too short, immediately announce the fact by interrupting the numerical display.

A traffic observer using a stop-watch with the outgoing observation equipment has already obtained useful traffic data, including for example the setting-up and clearing times of the international automatic calls, while operators under training have been helped by seeing the results of their keying appear as a display of numerical digits. The incoming observation equipment has satisfactorily displayed many trains of digits without attention, and in the case of an occasional misrouted call, has prevented much fruitless search by indicating whether the international equipment or the national network was at fault. It has also been used extensively and found valuable in testing equipment for national trunk mechanisation.

ACKNOWLEDGMENTS

Equipment of the type described necessarily embodies ideas from many sources, and thanks are gratefully offered to all who have assisted in the theoretical or practical stages, particularly to colleagues in the Electronics Group of Telephone Branch who designed and tested the electronic counting circuits, and to those in the Circuit Laboratory who built, tested and installed the completed apparatus.

Book Review

"Thermionic Valves." W. H. Aldous, B.Sc., D.I.C., A.M.I.E.E., and Sir Edward Appleton, F.R.S. Methuen & Co., Ltd., London. 160 pp. 98 ill. 9s. 6d.

The rapid development in the science of thermionic valves has made it difficult for the engineer and student to keep abreast in this sphere of knowledge. The latest edition of this book fulfils the need for an up-to-date but simple exposition of the theory and application of vacuum tubes and fully meets the requirement that it should be of use to "the student of general physics who has not made a special study of radio frequency phenomena." Its clear, straightforward presentation should

appeal to the engineer who finds that a return to fundamental principles is necessary.

The brevity of treatment is compensated for by the inclusion of a comprehensive bibliography, from which further information can be sought. The chapters on valves for use at ultra-high frequencies introduces the basic principles of electron transit time effects and the utilisation of these in valves such as Klystron, Magnetron, etc.

The book is an excellent foundation for a serious study of vacuum tubes and a useful addition to the student's library.

H. E. S.

A Combining Unit for Superimposing Two Television Pictures on the Same Cathode Ray Tube

D. WRAY, B.Sc. (Eng.), A.M.I.E.E.†

U.D.C. 621.397.62 : 621.397.82

Apparatus is described which can combine a television signal with any other waveform to give the visual effect of the two signals simultaneously, without the picture losing synchronism. This can be used to simulate the effect of various types of interference on television pictures; if the equipment is employed to display a picture after transmission superimposed on the original picture, the delay of the system is demonstrated by the displacement between the two pictures.

Introduction.

IT is often useful to have available for reference photographs illustrating the many different types of television distortion and interference that can arise from time to time. The process of photographic reproduction, by altering the contrast range of the original picture and by printing the image on a very much reduced scale, has the effect of masking the visual effect of most forms of interference, and it has been found necessary to inject interference at a high level into an interference-free television signal to achieve a distinctive result. This injected interference is often sufficient to disturb the synchronism of the picture, so producing a valueless photograph. Another requirement is an illustration of two superimposed pictures with a short delay between them to simulate the effect of reflections on a received picture. In this case direct addition of the two signals (the original and the delayed) does not give a satisfactory result, for the picture monitor fails to synchronise on the confused mixture of two sets of synchronising pulses, each distorted by the presence of the other.

A unit has been made which can combine a television waveform with any other waveform (e.g. an interfering signal, or another television signal, or the same signal delayed in time), combining the visual effect of both signals, but without the original picture losing synchronism. Since such a device can be used to superimpose two television pictures which are identical except for the time delay between them, the sent and received signal over a long-distance television looped transmission system can be displayed simultaneously; the delay between the signals is then evident in the displacement of one picture relative to the other.

Requirements.

In the following description the interfering signal has been taken to be another television signal identical to the original but delayed in time; the arguments hold good, however, for all types of interfering signal.

A train of television line waveforms, after reflection or passing through a looped transmission system, is delayed by a time which is not, in general, an integral multiple of the line period. For example, the first line waveform in the picture may, after transmission, correspond in time to the middle of, say, the n th line of the original, and should these two waveforms be added directly without any modification, the effect would be as illustrated in Fig. 1. The unusual picture waveform has been chosen to emphasise two disadvantages that would attend the direct addition of the two signals. The first is that, should the synchronising pulse of the delayed signal correspond to a period of black level in the original, a spurious synchronising pulse would appear in the combined waveform, as at "a". The second effect is that any picture detail occurring in the delayed picture at the same time as a synchronising pulse in the original will add to and distort this pulse, as at "b". If either of these two effects is present the synchronisation of the display monitor will be disturbed.

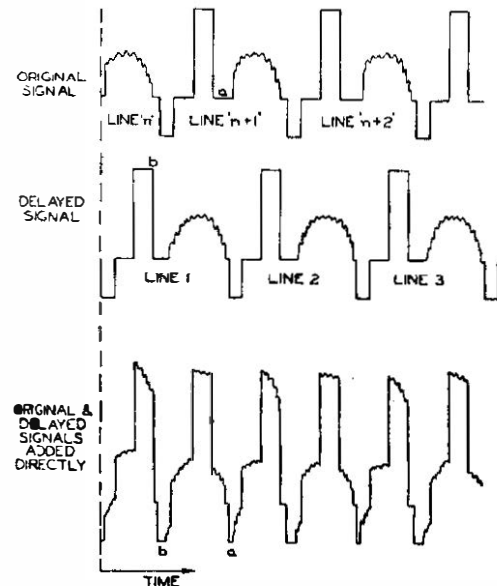

FIG. 1.—DIRECT ADDITION OF TWO SIGNALS.

These undesirable consequences of direct addition can be overcome by clipping the synchronising pulses from the delayed signal, whereupon no spurious synchronising pulse is introduced into the combined waveform; and by blanking the delayed signal for a period corresponding to the synchronising pulse in the original waveform, distortion of the desired synchronising pulses in the final signal is avoided. This is shown in Fig. 2. When the interference is a waveform

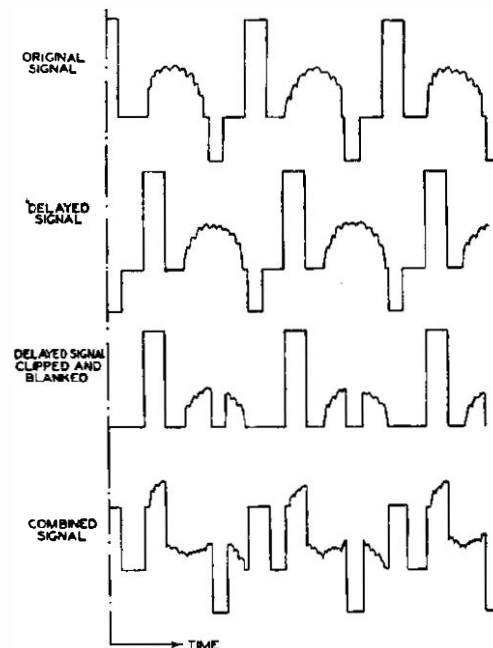

FIG. 2.—ACTION OF COMBINING UNIT.

† Executive Engineer, Radio Experimental and Development Branch, E-in-C.'s Office.

which is not that of a television signal, the clipping process should remove everything below the voltage corresponding to black level in the final combined waveform; the same blanking process during the synchronising period is required.

A combining unit has been made which performs the operations described above, and, since it was recognised that control over the relative amplitudes of the two signals and the synchronising pulses would be a useful facility, this feature has also been incorporated.

Design.

A block schematic diagram of the combining unit is given in Fig. 3.

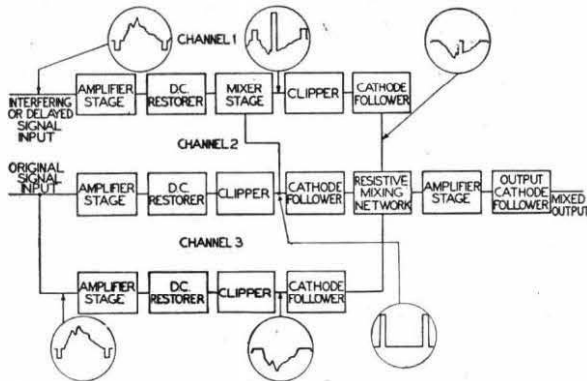

FIG. 3.—BLOCK SCHEMATIC DIAGRAM OF COMBINING UNIT.

The action of the unit is perhaps most easily understood if it is considered as consisting of three channels, concerned with: (1) the blanking and clipping of the interfering or delayed signal, (2) the synchronising pulses of the original signal, and (3) the picture detail of the original signal. The outputs from these three channels are mixed, and then amplified in a common output stage.

Considering Channel 2 first, the original signal is amplified by a pentode amplifying stage, and then d.c.-restored by the action of a crystal valve and a capacitor. This process of d.c. restoration keeps the tips of the synchronising pulses at a constant voltage relative to earth, irrespective of the picture content of the signal. A crystal valve clipping circuit clips off the picture content at black level, and the resulting constant-amplitude inverted synchronising pulses are fed both to Channel 1, where they are used to blank the delayed signal, and also through the Channel 2 cathode follower into a 1,000-ohm resistive star mixing network.

The interfering or delayed signal is connected into Channel 1, where it is first amplified, then d.c.-restored, and then fed into a double-triode cathode-coupled mixer stage. The other signal into this mixer is the train of positive-going synchronising pulses derived from Channel 2. The combined waveform across the common cathode load of the mixer valve is therefore the interfering picture waveform, inverted in phase, blanked out by the original signal synchronising pulses. This composite signal is clipped at black level and passed through a cathode follower into the 1,000-ohm mixing network; if the interfering signal is a television waveform the clipper will remove both the synchronising pulses and any superfluous blanking pulse.

The signal to Channel 3 comes from the same input as Channel 2, but is separately amplified and d.c.-restored. A clipping circuit removes the synchronising pulses from the waveform, which is then passed through a cathode follower stage into the same mixing network as mentioned above.

Thus, at the star point of the resistive mixing network, there are the positive-going synchronising pulses derived from the original signal via Channel 2; the inverted, clipped, and blanked interfering or delayed picture wave-

form from Channel 1; and the inverted and clipped picture waveform from Channel 3. The amplitudes of these three constituents can be controlled by potentiometers in the cathode circuits of the cathode-follower stages which terminate each channel, thus enabling the picture-to-synchronising-signal ratio in the composite signal to be set to 70:30, the standard ratio used in the British television system. The combined signal is then amplified (and inverted) by a pentode amplifying stage and delivered through a cathode follower stage at 1V D.A.P. into a 75 ohm load.

It is important to realise that in each channel the circuit from the d.c.-restoring crystal valves to the final mixing network is D.C.-coupled, so the average D.C. levels of the two signals in the combined output waveform do not vary relative to each other as the picture content changes. This prevents the picture waveform from sinking into the "blacker than black" region during scenes of high average brightness—an effect which would disturb the synchronisation of the monitor.

Applications.

The combining unit has been used extensively to superimpose various forms of interference on to television pictures; photographs of these pictures then assist officers to recognise any particular interference and to trace it to its source. A photograph of a television picture mixed with an audio waveform, simulating the visual effects of "sound break-in," is shown in Fig. 4; the combination of the two



FIG. 4.—PICTURE WITH ADDED AUDIO SIGNAL, ILLUSTRATING "SOUND BREAK-IN."

waveforms was effected by the combining unit. The unit is particularly useful when the interfering signal is another television waveform (such as an echo signal) for the clipping process removes the synchronising pulses of the delayed signal and prevents false triggering of the monitor time-bases.

The combining unit was used when Sir Archibald Gill, in his presidential address to the Institution of Electrical Engineers, demonstrated in public for the first time the transmission of television pictures over the cable loop London-Birmingham-London. A photograph of a picture after transmission round this loop and superimposed on the original is shown in Fig. 5. The amount of vertical and horizontal displacement will, of course, depend both on the delay introduced by the transmission path, and the time taken to scan one line on the monitor. In this example, the delay caused by the circuit is approximately 1.4 milliseconds equivalent to a displacement of about $27\frac{1}{2}$ lines in the picture



FIG. 5.—PICTURE TRANSMITTED ROUND LOOP LONDON-BIRMINGHAM-LONDON AND SUPERIMPOSED ON ORIGINAL.

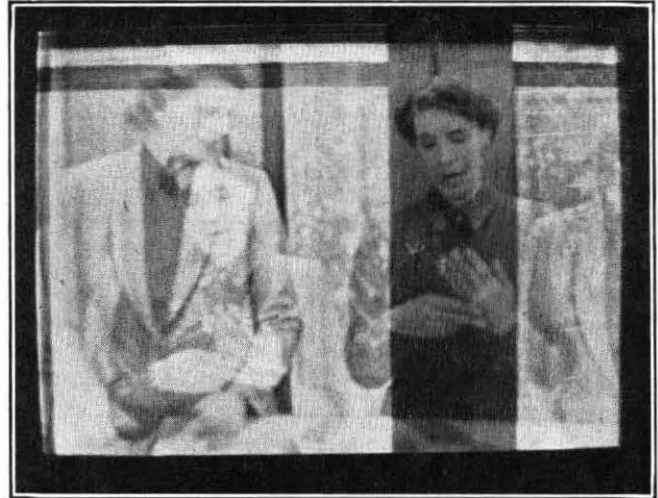

FIG. 6.—PICTURE TRANSMITTED ROUND LOOP LONDON-HOLME MOSS-LONDON AND SUPERIMPOSED ON ORIGINAL.

(allowing for the interposed lines of the interlaced frame). In the third photograph, Fig. 6, the signal has traversed the loop London-Holme Moss-London, a distance of 400 miles, giving a displacement between the pictures of about $54\frac{1}{2}$ lines; this is equivalent to a delay of 2.7 milliseconds.

One phenomenon which has been observed when television pictures are transmitted round a long cable system, and which caused considerable speculation when first noticed, is rapid horizontal shifting of the displaced picture by as much as one-fifth of the horizontal line scan. This is apparently equivalent to a change of between 10 and 20 microseconds, and no mechanism could be thought of which would cause a large and rapid alteration in the delay of a transmission

system. It was then realised that the delay of the system was, of course, remaining constant, but that the line frequency, and hence the scanning speed, of the display monitor was changing as a result of variations in the mains power supply frequency at the picture source.

Since either of the picture waveforms can be controlled in amplitude independently of the synchronising pulses, the original or delayed picture can be "faded" up or down to increase the impact of the demonstration.

The unit has been found to be a useful addition to television laboratory equipment, and has proved to be very effective when demonstrating the long-distance transmission of television signals.

A 30-cwt. Transportable Gantry

It was decided in 1948 that some form of transportable crane or gantry on wheels would provide at a much reduced cost all the lifting facilities required of the conventional overhead travelling crane as formerly fitted in the power rooms of the larger exchanges and repeater stations. The gantry illustrated was therefore designed in the Engineer-in-Chief's Office, Power Branch, and 20 were ordered for distribution to Regions.

To enable the gantry to be easily transportable from one building to another and for easy access to power rooms, it was made up in three main parts, i.e., the two vertical members and the top cross member, which are bolted together by eight $\frac{5}{8}$ -in. fitted bolts. The three members can be carried in a light lorry and the gantry can be assembled and dismantled easily and quickly in power rooms. The gantry is made up of channel and T-sections welded together wherever possible to reduce the weight to a minimum, and runs on four ball-bearing swivel castors with 6-in. diameter ball-bearing steel rollers. On the top member runs a small trolley with two 3-in. diameter rollers supporting a chain pulley block.

The gantry is designed to lift a maximum load of 30 cwt. and was tested at works with a load of 45 cwt. The overall dimensions are 10 ft. high, 8 ft. 6 in. wide and 4 ft. in depth and a maximum lift of approximately 7 ft. 6 in. above floor level can be obtained. The gantry can be run over plant up to approximately 5 ft. 6 in. in width.

J. H. A.

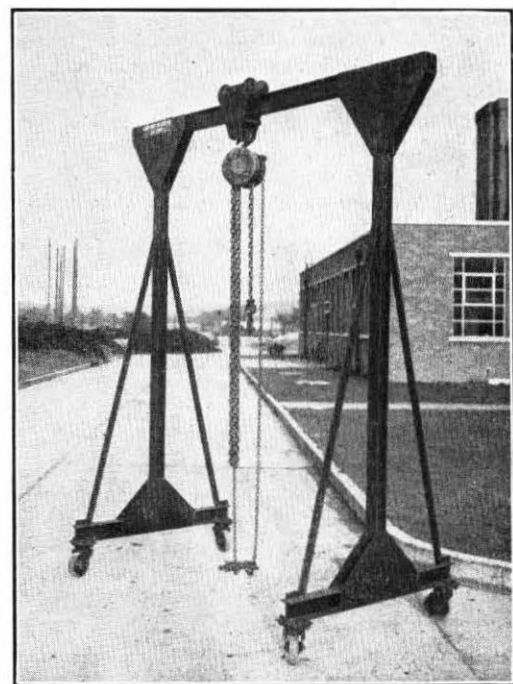

THE GANTRY ASSEMBLED FOR USE.

A Telephone Transmission Reference Circuit using Adjustable Interruption Distortion

D. L. RICHARDS
and J. N. SHEARME†

U.D.C. 621.317.74:621.3.094.3.

Some methods of telephone transmission are being investigated which subject speech signals to various types of non-linear distortion. The assessment of the usefulness of such systems is most easily made in terms of a reference circuit in which a distortion similar to non-linear distortion provides the adjustable degradation. This article describes a reference circuit which has been used for this purpose.

Introduction.

THE "goodness" of a telephone circuit is measured by comparison with a graduated scale forming part of an adjustable reference telephone circuit, i.e. the setting of the reference telephone circuit is noted, which corresponds in effectiveness with that of the circuit being measured. Such a direct comparison can be made subjectively by conversing alternately over the two circuits and adjusting the reference circuit until the effectiveness of each is judged to be the same.

Usually, however, a less direct comparison is desirable and some relevant measurement is made such as the proportion of unrelated words which can be received correctly. This measurement is made on the circuit under test and on the reference circuit, the latter being adjusted until the two measurements are equal. The actual proportion of words received correctly is virtually an "uncalibrated" reading since different results would be obtained depending on the skill of the subjects. The reading is transferred to a calibrated scale when the equivalent setting of the reference circuit has been obtained.

The effectiveness of telephone circuits ranges widely. At one end of the range there are those circuits so good that the speech received over them is barely distinguishable from that received over a direct air path; at the other end are those so bad that a message can be transmitted only with great difficulty and at the expense of much time. Between these extremes are those commonly encountered where a varying but not excessive amount of effort (particularly mental effort) is necessary.

In view of this large range to be catered for it is not surprising that more than one kind of relevant measurement must be available. It is thus appropriate to assess very good circuits by the criterion of "indistinguishability"; medium circuits by criteria of intelligibility such as the proportion of nonsense words correctly received, or the proportion of simple sentences which are understood immediately without mental effort (called the "immediate appreciation"); and bad circuits by the time required to get a given message across (or the number of messages transmitted in a given time; this is termed the "message rate").

Requirements of Reference Circuits.

A reference circuit must be easily specifiable in simple objective terms and capable of adjustment over the whole range of effectiveness. This implies that it must basically be a very high-quality circuit (to cater for the "good" end), but capable of being progressively degraded to complete unusability. It has been customary in the past to assess commercial telephone circuits in terms of the sensitivity setting of a high-quality telephone circuit such as described by Swaffield and De Wardt.¹ Assessment in this way in terms of circuit sensitivity or faintness of received speech is only appropriate if assessment is required under very faint listening conditions. It is often more appropriate to use a similar high-quality circuit degraded by the introduction of

random noise. If the noise is adjusted to the same shape of spectrum as that of the speech, the signal/noise ratio is particularly easy to specify as it is the same at all frequencies within the speech frequency range (say, 50 c/s–8,000 c/s). Such a circuit is useful for assessing telephone circuits used under comfortably loud listening conditions. With such a circuit assessment is made in terms of equivalent signal/noise ratio in decibels.

THE REFERENCE DISTORTION CIRCUIT

Methods of telephone transmission in which speech is subjected to non-linear distortion, such as "clipping", or those using analysis-synthesis like the Vocoder,² can be assessed more easily in terms of a reference circuit which makes use of a distortion, similar to non-linear distortion, as its adjustable degrading feature. Such a circuit has now been developed which distorts by interrupting the speech path at a comparatively high frequency (500 c/s).³ The interruption is adjustable in its on/off ratio or speech-time fraction. Thus 100 per cent. speech-time fraction means that the speech is on 100 per cent. of the time and the circuit is distortionless, but as the speech-time fraction is reduced the circuit becomes progressively worse until at 20 per cent. it is virtually unusable. Such a device has been used successfully for assessing telephone circuits in which the speech is subjected to severe clipping.

It is, of course, desirable to know the "rate of exchange" between adjustments of the various reference circuits. It so happens that a rather simple relationship has been found experimentally to exist between speech-time fraction and equivalent signal/noise ratio so that assessments in terms of one can be expressed also in terms of the other. This relationship is that the signal/noise ratio in decibels is proportional to $\log \{p / (1 - p)\}$ where p is the speech-time fraction. This is analogous to considering the "speech on" time as signal power and the "speech off" time as noise power and then calculating the signal/noise ratio in decibels.

Characteristics of the Circuit.

The reference distortion circuit consists essentially of the high-quality telephone circuit¹ containing an electronic switch which makes and breaks the circuit in a specified way. It has been found that this reference circuit is most suitable when the make and break periods are irregular and have a mean interruption frequency in the range 100 c/s to 1,000 c/s. Within this range neither the "quality" nor the severity of distortion vary very greatly with frequency. The amount of distortion is however readily controlled by choice of the speech-time fraction.

The irregular interruptions are controlled by a random noise voltage which is obtained by amplification of the noise e.m.f. developed in a thyatron tube. This noise has (theoretically) a continuous flat spectrum, and to employ it to control interruptions having a finite mean frequency it is applied through a low-pass filter having a cut-off frequency of 1 kc/s. The output from the filter is a random voltage whose waveform cuts the zero axis at a mean rate of about

† The authors are, respectively, Senior Executive Engineer and Executive Engineer, Post Office Research Station.

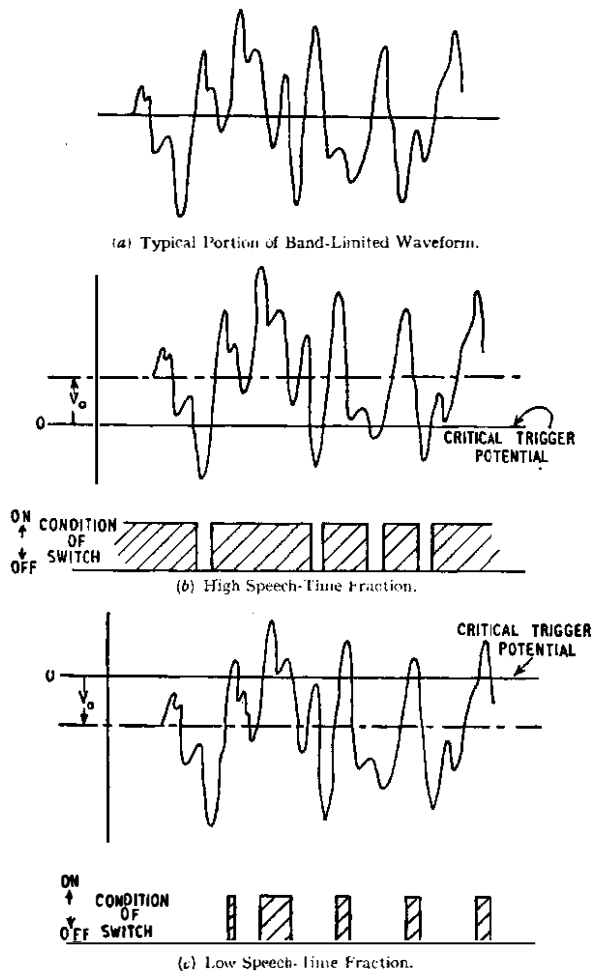

FIG. 1.—USE OF BAND-LIMITED NOISE VOLTAGE TO PRODUCE RANDOM INTERRUPTIONS WITH CONTROLLABLE SPEECH-TIME FRACTION.

1,150 times per second. A typical portion of this band-limited waveform is illustrated in Fig. 1 (a).

The waveform is superimposed on a steady voltage V_o which may be varied continuously over a range of positive and negative values, and the combined voltage is applied to the input of a trigger circuit. The D.C. output of the trigger circuit can have only one of two values, depending on whether the input voltage is greater or less than zero. If the input exceeds zero then the trigger output is high and it is arranged that under this condition the speech path is "made"; if the input voltage is less than zero the trigger output is low and the speech path is "broken."

The effect of the combined input voltage on the state of the speech path when V_o is positive is shown in Fig. 1 (b).

It can be seen that the input to the trigger exceeds zero for most of the time, only becoming negative during occasional large negative peaks of the noise voltage; consequently the speech path is only rarely interrupted, and the durations of the interruptions are short, i.e. the speech-time fraction is large. If V_o is progressively reduced, the frequency and duration of interruptions increase until when V_o is zero the frequency reaches a maximum value of 575 interruptions per second (i.e. half the mean rate at which the band-limited waveform crosses the zero axis). Further reduction of V_o continues to increase the duration of interruptions, but the frequency starts to decrease again. The state of affairs when V_o reaches a fairly large negative value is shown in Fig. 1 (c). The speech-time fraction can therefore be continuously varied over the whole range 0-100 per cent. by suitable variation of V_o .

It is an undesirable characteristic of the system that the mean frequency of interruption changes as the speech-time fraction is varied, but fortunately within the useful range of speech-time fraction (say 10-90 per cent.) the mean interruption frequency only varies in the range 200-575 interruptions per second and variations in this range have been shown to be unimportant.

An important feature of the circuit is that a direct indication of the speech-time fraction is easily provided. The output from the trigger circuit is applied to a moving-coil meter calibrated from 0-1 mA. The circuit is arranged so that when the trigger output is low (speech path interrupted) no current flows in the meter and when the trigger output is high (speech path uninterrupted) the meter current is 1 mA. Thus, if the trigger spends, say, 70 per cent. of the time on the high position, the meter indicates a mean current of 0.7 mA, which is a direct reading of the speech-time fraction.

Outline of Circuit Arrangements.

The circuit diagram of the switching apparatus is shown in Fig. 2. The D.C. component (V_o) of the input to the trigger circuit V1, V2 is provided in one of three ways selected by the switch SWA. The first 14 positions of this switch provide the potentials required for fixed values of

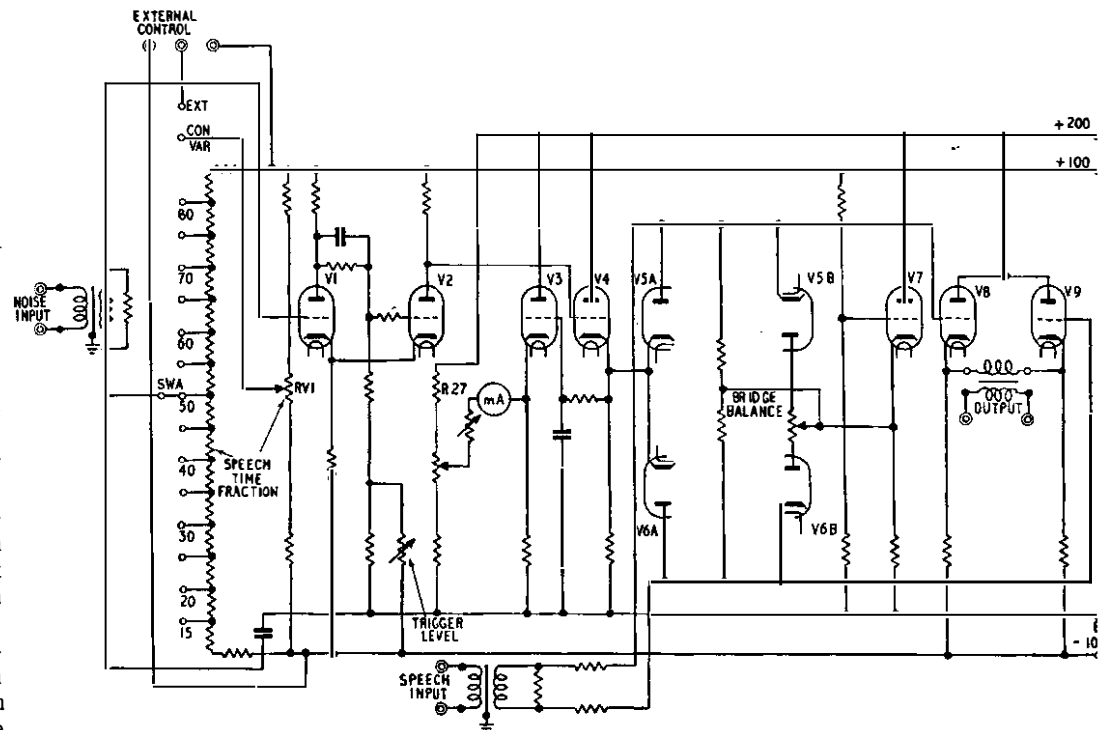

FIG. 2.—THE REFERENCE DISTORTION CIRCUIT MODULATOR.

speech-time fraction from 15–80 per cent. in 5 per cent. steps, position 15 connects a potential divider (RV1) giving continuous control over the whole range of speech-time fractions, and a further position enables an external control to be used.

The cathode circuit of V3 contains the speech-time fraction indicator; a smoothing circuit is interposed between this valve and V4 so that the variations of trigger output are averaged over a time of several seconds and the indicator gives a steady reading.

The double diodes V5, V6 constitute the switch or modulator, and the switching voltage is the difference in potential between the cathodes of V4, V7. The speech output is taken from the push-pull cathode followers V8, V9. The output impedance is approximately 50 ohms and the input impedance for both noise and speech paths is 600 ohms. The frequency characteristic of the speech path is flat within ± 1 db. from 50 c/s to 10 kc/s and the overall gain of the speech path is approximately zero when the path is uninterrupted and -50 db. when interrupted.

Performance of the Circuit.

Fig. 3 shows the percentage of sounds correctly received by a trained crew over the reference distortion circuit (sound articulation score) as a function of speech-time fraction.

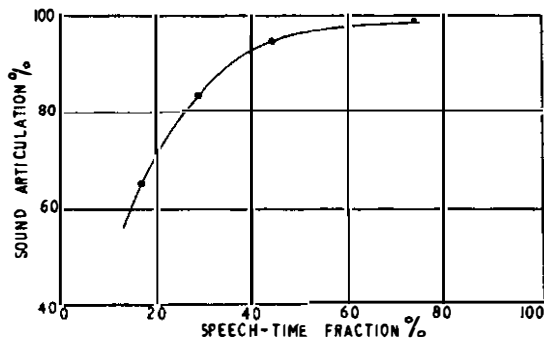

FIG. 3.—SOUND ARTICULATION AS A FUNCTION OF SPEECH-TIME FRACTION.

The form of this curve depends to some extent on the frequency of interruption; for example, if we consider a very low mean interruption frequency, say one interruption per minute, the articulation must be equal to the speech-time fraction. The range of interruption frequencies over which the reference distortion circuit works depends on the filter from which the band-limited controlling noise is derived. Consequently the articulation curve depends somewhat on this filter. It has been found, however, that even a 50 per cent. change in the cut-off frequency of the filter produces negligible change in the articulation score, and a very precise specification of the filter is therefore unnecessary.

Subjectively, speech signals passed through the circuit sound rather like clipped speech over the range of speech-time fractions 20–90 per cent. Below about 20 per cent. the speech is almost wholly unintelligible, whilst above 90 per cent. the interruption begins to be heard as distinct clicks (since the frequency of interruption is then low).

CONCLUSIONS

Assessment of telephone circuits must take into account how and by whom they are used. Effectiveness in any absolute sense can therefore be expressed only in terms of the behaviour of the actual users. The users themselves and their behaviour are both very difficult to define, so that recourse must be had to suitable objectively specifiable measuring scales or reference circuits. With the aid of the reference distortion circuit described here it would be possible to avoid fruitless discussion between persons who have each heard only one of the distortions as to whether speech subjected to distortion A was better or worse than speech subjected to distortion B; assessments of the distorted speech in terms of equivalent speech-time fraction would probably settle the argument because such assessments would be substantially independent of the assessor.

REFERENCES.

- Swaffield, J., and de Wardt, R. H. "A Reference Telephone System for Articulation Tests." *P.O.E.E.J.*, Vol. 43, p. 1, April 1950.
- Swaffield, J. "The Potentialities of the Vocoder for Telephony over Very Long Distances." *P.O.E.E.J.*, Vol. 41, p. 22, April 1948.
- Miller, G. A., and Licklider, J. C. R. "The Intelligibility of Interrupted Speech." *Journal Acoustical Soc. Amer.*, Vol. 22, pp. 167–174, March 1950.

Book Review

"Elementary Electrical Engineering." A. E. Clayton, D.Sc., M.I.E.E. and H. J. Shellev, O.B.E., B.Sc., A.M.I.E.E. Longmans, Green & Co., Ltd. 490 pp. 340 ill. 14s.

This excellent text book, first published in 1927, already occupies an established place amongst the works that students of general electrical engineering have found worth retaining in their libraries when their examination days have passed. Its appeal lies not so much in any originality of treatment—for that is difficult to achieve in a book covering a syllabus restricted to the electrical sections of the Ordinary National Certificate—as in its thorough, robust approach and freedom from excessive elaboration.

The authors have clearly had much experience in teaching the principles of A.C. theory, and the operation of motors and generators. They emphasise practical points which help the student to unite the theoretical analysis of a problem with the technique of experimental verification in the laboratory. The application of vector methods to electric circuit analysis is well covered, and vectors are freely used and illustrated by worked examples in the text: vector diagrams are often drawn

to a scale which is itself reproduced in the diagrams, so that students can make checks by direct measurement.

The use of Calculus is in general avoided, which is perhaps unfortunate as Ordinary National Certificate candidates should be encouraged to employ the Calculus, rather than be invited to avoid its use. Two rather more advanced chapters have been added at the end of the book to cover the solution of simple networks and the general relations arising in series and parallel resonance, and these add considerably to its value. An interesting chapter is included on illumination, embracing the geometry of illumination photometry and the general design of electric lamps. Primary and secondary cells are discussed; there is also a valuable outline account of modern insulating materials and their properties.

Students who are learning the groundwork of electrical engineering preparatory to proceeding to more specialised aspects, such as telecommunications, will find this book valuable as an aid to study and useful for reference during their later years. Teachers of electrical engineering will also welcome the many pages of exercises, with answers, that are collected under chapter headings at the end of the book.

C. F. F.

I.P.O.E.E. Library No. 847

Book Reviews

"Alternating Current in Telecommunications." W. T. Palmer, B.Sc.(Eng.), Wh.Ex., M.I.E.E., A.M.I.Mech.E. Sir Isaac Pitman & Sons, Ltd. 36 pp. octavo. 40 ill. 4s.

This short work is intended to be a non-mathematical introduction to the subject of "alternating currents" with particular reference to the use and importance of such currents in telecommunications practice. The author introduces his subject by a short examination of the mechanical oscillation of a swinging pendulum, and follows this by brief descriptions of typical alternating-current generators. After a short and perhaps somewhat unconvincing description of the behaviour of inductance and capacitance in an A.C. circuit, the book proceeds to simple descriptions of 2- and 3-electrode valves and their use as rectifiers, amplifiers and in elementary oscillator circuits.

The final section of the book describes the principles of voice frequency telegraphy and carrier telephone systems with simple and interesting explanations of band-pass filters, methods of modulation and the characteristic features of wide-band transmission systems.

Although the book is not intended to replace the normal text-books on alternating current theory, it should be of interest, as supplementary reading, to young students who are just starting on a course of studies in telecommunications engineering. Some may consider that the price is somewhat high for a production of this size.

J. A.

"Rinehart Mathematical Tables, Formulas and Curves."

H. D. Larsen. Chapman & Hall. 264 pp. 90 ill. 15s.

This book, which has been compiled for the use of engineers and physicists, is divided into two parts. The first part consists of 160 pages of mathematical tables, while the second part consists of 100 pages of reference formulae and curves.

In the first part, the 27 tables contain the usual five-figure logarithmic, trigonometric, exponential and hyperbolic tabulations well known to engineers. There are also tables of the logarithms of trigonometric functions which are useful for certain specialised calculations. Once logarithmic calculation is replaced by mechanical computation the machine operator needs tables of powers, roots, factorials and reciprocals and such tables are given in this book.

All these tables have been printed in the "modern face" or equal-height figures (1 2 3 4 5 6 7 8 9 0) and too many rules have been used, with the result that the pages have a very heavy appearance. There can be but little doubt that the "old-style" figures with heads and tails (1 2 3 4 5 6 7 8 9 0) are less fatiguing to read and so less liable to misreading than modern face figures.

In the second part of the book, in addition to the Greek alphabet, weights and measures, physical constants, there are fundamental reference formulae from Plane and Solid Geometry, Algebra and Trigonometry, Hyperbolic functions, Differential and Integral Calculus, etc. The outstanding feature of this part, however, is Section II which gives curves for reference. This collection must be one of the most complete sets published and is superior to the collection given in Chapter XXI of Granville's "Differential and Integral Calculus."

This book will form a useful addition to an engineer's reference library.

H. J. J.

"Practical Television." T. J. Morgan. Ward Lock & Co., Ltd. 288 pp. 198 ill. 18s. 6d.

A number of books have been written in an endeavour to explain television in simple language; this is probably the first that really starts from first principles. At least a third of the book is devoted to the fundamentals, not only of television, but of magnetism and electricity and radio in general. The whole field is covered from wave motion and atomic particles to colour television. In a book attempting to cover so wide a field it is inevitable that there should be some passages open to criticism. For example the discussion of single-sideband

working on page 86 contains inaccuracies. In the first place, suppressed carrier working *is* used in radio transmission as well as for carrier telephony on lines. Secondly, single-sideband working is *not* used for television transmission because, as yet, no satisfactory method of generating single-sideband television signals has been developed. The asymmetric-sideband method employed is really a double-sideband system for the low-frequency modulation components, merging into a single-sideband system for the high-frequency modulation components. Thirdly, the author suggests that demodulation, in effect, removes one of the sidebands and the carrier, but does not explain how this is so. In fact, of course, demodulation removes the carrier and both sidebands, replacing them by a signal in the same band as the original modulating signal. Can it be that the author has fallen for the hoary old fallacy that removal of half the waveform by a half-wave detector is equivalent to removing one sideband; and that the capacitor across the diode load then removes the carrier?

The book is profusely illustrated with 22 excellent photographs and a large number of line drawings. It is a pity that the numbering sequence for the latter starts from 1 in each chapter, for a reference on page 148 to Fig. 5, appears, after much searching to refer to a Fig. 5 in a much earlier chapter.

Mr. Morgan has shown great courage in attempting to write such an all-embracing work. The result is not a book for the specialist television engineer but one that will be read with enjoyment by technical workers in other fields or by the layman with a scientific bent who wants to know how his television works.

T. K.

I.P.O.E.E. Library No. 2044.

"Harmonics, Sidebands and Transients in Communication Engineering." C. Louis Cuccia, M.S. McGraw-Hill Book Co., Inc. 1952. 465 pp. 254 ill. 76s. 6d.

The development in telecommunications during the last two decades, which include the advent of radar and the spectacular growth of television, has been rapid because many of the fundamental problems have been such as to yield to mathematical analysis. This progress has forced the research engineer to apply difficult mathematical methods to the solution of his problems: for, unless the power of engineering analysis keeps pace with the growing difficulty of its technical problems, rapid progress will stop. This demand has created the need for a comprehensive text-book that discusses the application of the Fourier and Laplace analyses to the modern field of communication engineering, and the present volume has been designed to fill this gap.

This new text-book offers a broad presentation of the theory of linear and non-linear electrical systems; emphasising physical principles, the author shows how transient and modulation problems can be analysed mathematically. Progressive chapters treat the fundamental concepts of electromagnetic wave transmission, radar, television and ultra-high-frequency systems. Although most of the material has been published before, the student will appreciate the discussion of spiral-beam frequency modulation systems, cavity resonators, transistors and other topics which have so far only appeared in periodical literature. A wide selection of problems and review exercises is included with each chapter.

In this book the mathematics of harmonic and transient analysis is discussed from the viewpoint of the theory of functions of a complex variable and not treated merely as "advanced computing for engineers." But the discussion of the fundamentals of complex theory given in the first chapter is vague and unsatisfactory: in this connection the student may find it an excellent exercise to deduce the formulæ given in this chapter by an obvious extension of Cauchy's theorem, stated on page 13. For the analysis of simple electrical systems described by ordinary linear differential equations, the use of the theory of functions of a complex variable is not essential; but it is essential for the more complicated systems described by partial differential equations and discussed in this book. The early chapters describe the application of the Fourier and Laplace analyses to such systems and the student will observe that the author has omitted to divide the Laplace transform $f(s)$ of the time function $f(t)$ by the complex variable S

($= \alpha + j\omega$). This omission means that throughout this book the function $f(t)$ differs from $f(s)$ in dimensions, and direct integration (where it is possible) is rendered more difficult. The student will also observe that the author has tacitly assumed that $f(t)$ is known, or known to satisfy a given differential equation from $t = 0$ to $t = \infty$, and this is never true in a physical problem, although it may be true in a purely mathematical one. This introduces a doubt about the validity of some of the mathematical solutions, and the critical student will regret that the author has not discussed questions of mathematical rigour and the associated existence theorems.

In connection with this criticism it must be pointed out that the principal aim of the present volume is the analytical exposition of harmonics, sidebands and transients in communication engineering and not the teaching of mathematics. Nevertheless, those questions of rigour which the author has not discussed are very important; without such a discussion it will be difficult for a critical student to have complete confidence in some of the mathematical solutions given in this book. There is, however, one thing that can be stated with complete confidence: the student who tackles the problems and exercises given in this excellent book will need far more vigour than rigour.

H. J. J.

"Practical Electric Wiring." H. P. Richter. McGraw-Hill Publishing Co., Ltd. 574 pp. 420 ill. \$3.75.

In the U.S.A., most States have laws which require the provision of the National Electrical Code, to be observed in the territory involved and, in addition, the National Board of Fire Underwriters has established a testing organisation to which manufacturers may submit their products for approval and labelling if found to meet specified minimum requirements. In this, the third edition of Mr. Richter's book, the Methods section has been revised to meet requirements of the 1947 National Electrical Code. The first part of the book covers the theory and basic principles, while the second and third parts deal with the actual wiring of residential and farm buildings and non-residential projects. The scope is restricted to the wiring of buildings of limited size and at medium voltage (under 600V), skyscrapers with their special problems being excluded. The theory given is adequate for the requirements of the practical electrician for whom the book is intended. The planning of installations and descriptions of methods of wiring are naturally concerned with U.S.A. practice and the fittings illustrated are the projects of American manufacturers, but there is much information to make the book interesting and useful to British readers who may be concerned with the problems of getting good installation work at reasonable cost. The subject matter is well set out and the illustrations and diagrams make for easy understanding, particularly of the methods employed. The fact that the book has reached its third edition and has also been translated into foreign languages is evidence that it is regarded as authoritative on installation practice in the U.S.A. in accordance with the National Electrical Code.

W. T. G.

"Electrical Installation Work." T. G. Francis, M.I.E.E. Longmans, Green & Co., Ltd. 232 pp. 237 ill. 12s. 6d.

The reports on electrical accidents show how important it is that the "Wireman" should have a good knowledge of the whys and wherefores of installation work as well as sound practical training. In this book, the author has set out to give those engaged in electrical installation an insight into the technical side of their work. The book follows very closely the syllabus for the "B" Course in electrical installation work of the City and Guilds of London Institute and the student should have little difficulty in following the elementary theory. The Statutory Regulations and I.E.E. Regulations for the Electrical Equipment of Buildings, on which installation practice in this country is based, are quoted where necessary, and authority for the method described but the author has wisely refrained from detailed arguments on the Regulations.

A plain statement of the purport of a particular regulation and the description of the methods adopted to comply with it are best suited to the requirements of the apprentice electrician for whom the book is intended.

In addition to the chapters on supply systems, circuits, wiring systems, testing, etc., there are chapters on illumination, electrical heating, D.C. and A.C. machines, primary cells, secondary cells, electric bells and telephones. Having regard to the wide scope and the modest price of the book, detailed treatment of all these subjects cannot be expected but, even so, a Post Office Engineer with a bookcase full of engineering instructions may be forgiven for expressing surprise that telephones are covered in rather less than nine pages. Some reference to electric shock and its treatment, and amplification of the information on testing earth continuity, with particular reference to the use of methods employing currents comparable with those likely to be met in service, would have enhanced the value of the book. Since the book was prepared, the 12th edition of the I.E.E. Regulations has been issued, and no doubt the author will take opportunity of an early second edition to make such amendments as are necessary to cover the new Regulations.

W. T. G.

SHORTER NOTICES

"WIRELESS WORLD" DIARY 1953. Iliffe & Sons, Ltd. Morocco leather 6s. 1½d. Rexine 4s. 7d.

The 80-page reference section of the "Wireless World" Diary, now in its 35th year of publication, provides in tabloid form the kind of technical information so often needed by the radio man, but seldom readily available. The technical data, compiled by the staff of "Wireless World" includes circuitry, useful formulae (including, for example, frequency-wavelength conversion and extending the range of meters) and graphical design data for the estimation of coil windings and circuit constants. In addition to providing technical information, the diary gives details of standard frequency transmissions, addresses of radio organisations (both in the U.K. and abroad) and base connections for nearly 500 current valves.

"EXAMPLES IN ELECTRICAL CALCULATIONS." Naval Electrical Department, Admiralty. H.M.S.O. 507 pp. 263 figs. 17s. 6d.

This book was originally written to provide Naval students of Electrical Technology with a collection of worked examples and carefully graded sets of exercises covering the scope of many electrical examinations in the Navy. It also covers the requirements of students preparing for the Preliminary and Intermediate Grade examinations of the City and Guilds of London Institute in Electrical Engineering Practice, or for the Ordinary National Certificate in Electrical Engineering.

A knowledge of elementary mathematics by the reader is assumed.

"WORKED EXAMPLES FOR ADVANCED ELECTRICAL STUDENTS." D. I. Williams, A.M.I.E.E. E. & F. Spon, Ltd. 160 pp. 118 figs. 18s.

A book written to fill a gap in standard works for technical colleges, giving the detailed solution of selected problems of the type set in papers for the Higher National Certificate in Electrical Engineering and Part II of the I.E.E. Associate Membership examination.

"PHOTOGRAPHY IN INDUSTRY." Institute of British Photographers. 20 pp. 5s.

A brief but comprehensive survey of the wide scope of photography in industry. The report is supported by appendices covering the uses of photography, the training and qualifications of photographers, the planning of accommodation, and provision of equipment.

Notes and Comments

H. Faulkner, C.M.G., B.Sc.(Eng.), M.I.E.E., F.I.R.E.

It is a pleasure to record that Mr. H. Faulkner, Deputy Engineer-in-Chief, and Chairman of the Board of Editors of this Journal, has recently been honoured by the Institute of Radio Engineers in receiving a Fellowship. Membership in this American Institute is widely distributed among those working in radio engineering and allied fields, the grade of Fellow being one of particular distinction to which appointment is made by the Board of Directors solely on the basis of eminence and distinguished service.

The citation accompanying the award reads as follows:—

“For his engineering achievements in the field of world-wide radio communication, and his contributions to international agreement on telecommunications practices.”

Board of Editors

The recent appointment of Capt. C. F. Booth to the post of Deputy Director, External Telecommunications Executive, has meant his resignation from the Board of Editors. In congratulating him on this appointment, we wish also to express appreciation of the services he has rendered as a member of the Board. Mr. H. Stanesby has been co-opted to fill the resulting vacancy.

Binding of Volume 45

This issue of the Journal completes Volume 45 and readers are reminded of the facilities available for binding. Details will be found on page 190.

City and Guilds of London Institute—Insignia Award

The City and Guilds of London Institute has established an Award in technology to encourage the progressive student and advancement in technical knowledge and practical skill of those engaged in industry. The Award is intended to be a mark of distinction for those who have combined with sound practical training an adequate knowledge of the fundamental scientific principles of their industry, and have shown a capacity for leadership and administration, and for applying such wider knowledge to their particular industry.

A candidate upon whom “The City and Guilds of London Institute Insignia Award in Technology” is conferred will receive a Warrant specifying thereon the section of industry and the branch of technology in which his knowledge and skill are recognised, and under the Institute’s Royal Charter he will be authorised to use the insignia letters. “C.G.I.A.”

Candidates for the award must be not less than 30 years of age and must have had at least seven years’ suitable industrial experience subsequent to completion of apprenticeship or equivalent training. Possession of a First Technological Certificate of the Institute supported by passes in suitable ancillary subjects is also required, but, for an interim period, candidates may be accepted for consideration if they have gained an approved group of qualifications awarded by the Institute.

Various other conditions must be met by candidates and full details can be obtained on application to The Direct Department of Technology (I.A.), 31 Brechin Place, South Kensington, London, S.W.7. Applications should be accompanied by a stamped addressed foolscap envelope.

Institution of Post Office Electrical Engineers

London Centre

The programme for the second half of the 1952/53 session is as follows:—

Ordinary Meetings*

27th January.—“Coaxial Cables—Some Practical Aspects of their Design and Maintenance.” G. E. Rossitor, B.Sc.(Eng.), A.M.I.E.E.

16th February.—“An Approach to the Economics of P.O. Engineering Training.” F. C. Meade, B.Sc.(Eng.), A.R.C.S., A.M.I.E.E.

31st March.—“Alternatives to the Conventional P.C.L.C. Telecommunications Cable.” J. Gerrard, A.M.I.E.E.

12th May.†—“Engineering Accounting in the Post Office.” H. L. Beck (A.G.D.).

Informal Meetings‡

14th January.—“Telephone Call Office Maintenance.” H. C. L. Grafton, A.M.I.E.E. (Midland Region).

4th February.—“Methods of Investigation in the Telephone Branch Circuit Laboratory.” M. Mitchell, M.B.E., B.Sc.(Eng.), A.M.I.E.E.

4th March.—“The Problem of Supervision in the Post Office.” F. B. Wilcher and J. Meade, A.M.I.E.E. (South-Western Region).

22nd April.—“Re-organisation—The First Five Years from an Area Angle.” F. E. Plumpton, A.M.I.E.E., and L. W. Rapkin.

Additions to the Library

2043 *Television Principles and Practice*. F. J. Camm (Brit. 1952).

Deals with the principles and practice of television transmission and reception in as non-technical a manner as possible, with the selection, installation and servicing of television receivers, and includes an up-to-date dictionary of technical terms.

* Held at The Institution of Electrical Engineers, Savoy Place, Victoria Embankment, W.C.2, commencing at 5 p.m.

† This meeting will be preceded by the Annual General Meeting of the Institution, commencing at 5 p.m.

‡ Held in the Conference Room, 4th Floor, Waterloo Bridge House, S.E.1, commencing at 5 p.m.

2044 *Practical Television*. T. J. Morgan (Brit. 1952).

A practical handbook presenting clearly and simply the technical background of television.

2045 *Sound Recording and Reproduction*. J. W. Godfrey and S. W. Amos (Brit. 1950).

An instruction manual for B.B.C. staff, intended to give a good grounding in the fundamentals of the subject with particular reference to B.B.C. equipment in current use.

2046 *The Magnetron*. R. Latham, A. H. King and L. Rushfor (Brit. 1952).

Intended to explain the construction and properties of the magnetron to those without specialised knowledge of high-frequency techniques, and also to provide a basis for those with specialised knowledge who wish for more detailed information.

2047 *Modern Wiring Practice*. W. E. Steward (Brit. 1952).

A guide to the most up-to-date and approved methods of wiring domestic and industrial premises for lighting and power.

2048 *Amplifiers*. G. A. Briggs and H. H. Garner (Brit. 1952).

Designed to fill the gap between Briggs’ other books “Loudspeakers” and “Sound Reproduction,” and should furnish ideas for the experimenter so that he may obtain the best results from the amplifier and associated circuit.

2049 *Modern Lighting Technique*. H. Hewitt (Brit. 1952).

Deals primarily with the more scientific aspects of modern lighting techniques.

2050 *Joint Consultation in British Industry*. Nat. Inst. Industrial Psychology (Brit. 1952).

A Report of an Inquiry sponsored by the Human Factors panel of the Committee on Industrial Productivity.

2051 *Radio, Television and Electrical Repairs*. R. C. Nor (Editor) (Brit. 1952).

A comprehensive and practical guide to the upkeep and repair of domestic radio and electrical equipment.

W. D. FLORENCE,

Librarian

Regional Notes

Scotland

RECOVERY OF THREE-POLE ROUTE

Another sturdy example of the craftsmanship of the overhead trunk route builders of half a century ago has disappeared. This was the "three-pole" route situated some 1,000 ft. above sea level over the very bleak Douglas moor in Lanarkshire on the main Glasgow-Carlisle road. It has been recovered to make way for road widening.

Originally it was a normal single-pole route erected about 1855 and carried a few long-distance telegraph circuits. It appears that, as the route developed with additional telegraph and trunk circuits, so complaints were received from the way-leave grantor of heavy losses to game. To minimise this difficulty the route was reconstructed during 1900 for approximately four miles, with the wires in a horizontal formation.

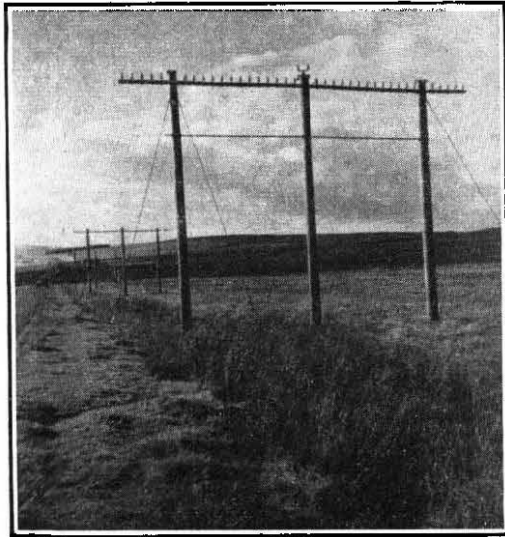

THE ROUTE AS IT WAS BEFORE RECOVERY.

The method of construction will be apparent from the photograph. Two additional 30-ft. stout poles were erected 10 ft. and 20 ft. distant from the original pole. A single oak arm 28 ft. long of 3 in. x 3 in. cross-section, and bored for 36 spindles at 8 in. spacing, was fixed in the normal way at the top of the poles. The three poles were connected with a tie rod 4 ft. 6 in. from the top. Due, presumably, to the mossy nature of the ground, a blocking pole was bolted across the three poles 2 ft. below ground level. The result was a very stable structure.

Officers who maintained the route many years ago claim that the horizontal formation was successful in reducing losses to game, and also that the route was, as would be expected, very free from faults.

R. J. G. B.

HIGHEST EXCHANGE IN GREAT BRITAIN?

The C.B.S. 2 exchange at Leadhills was recently converted to a U.A.X. 12.

The U.A.X. is situated in the village of Leadhills, which lies about 28 miles north of Dumfries, high up among the Lowther Hills. It serves the village of Leadhills and the neighbouring village of Wanlockhead. The site was chosen on relatively low ground in an attempt to be below the cloud and mist which so often enshrouds the village. Even so, the U.A.X. stands approximately 1,200 ft. above sea level and is thought to be the highest exchange in Great Britain.

Leadhills is aptly named, as some years before the late war it was a prosperous lead mining centre. There is ample evidence of this in the many disused workings which are scattered about. Increases in the price of lead over the past few years have caused some attention to be given to reopening the old workings, and prospecting is in progress just now.

From time to time throughout the centuries, gold has also been found in the area. Records show that during the sixteenth century the Scottish Crown was fashioned from Leadhills gold. There is still evidence that gold can be found, although in very minute quantities. Most of the villagers can produce a phial containing a few grains of gold which has been laboriously panned from the local burns.

R. J. G. B.

London Telecommunications Region

AN UNUSUAL TYPE OF TEST DESK

In London and some Provincial centres, the public can get direct access to engineering assistance by dialling "ENG." The Technical Officers who respond to this are being given a short training course in the Engineering Training School. This has created additional demand for occupancy of the School Test Desk positions, and the solution found to the difficulty may prove to be worthy of more general adoption for training purposes.

Test Desk positions for schools are hard to come by, are expensive in cost and installation time and are usually far from up-to-date! All these disadvantages have been reversed in the L.T.R. Engineering Training School by using a mock Test Desk position. As will be seen in the picture, an exactly full-size photograph is mounted on hard-board and suitably supported. In just enough places to make the position "work" sufficiently for the needs of the training, real equipment is substituted for the flat picture by slotting the mount.

The training consists mainly in general departmental practice, public relations and resourcefulness, and the practical work which comprises the bulk of the course consists largely in dealing with a range of difficult situations which are presented

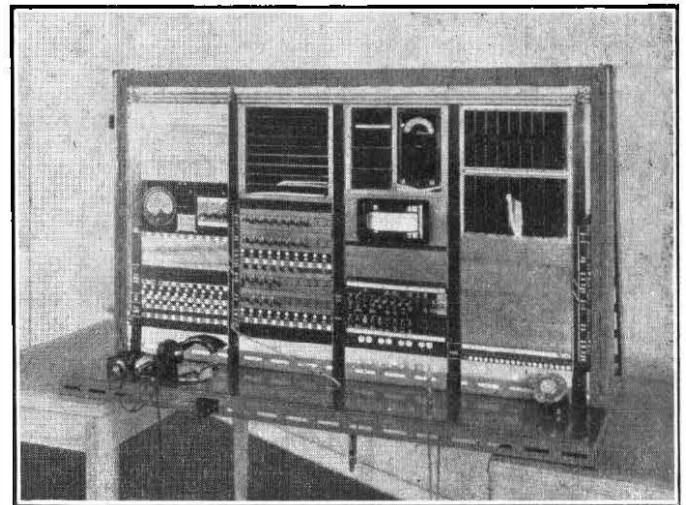

MOCK TEST DESK POSITION FOR "ENG." TRAINING.

to the students telephonically while they are manning the dummy positions. The proper sense of environment was successfully produced by the model and students' reactions did not differ from that obtained when the real Test Desks were used.

The success of this model has led to its extension to other courses, particularly those for youths-in-training.

R. A. A.

HARROW AND WEALDSTONE TRAIN CRASH

The following notes have been compiled not with the intention of recalling any of the poignant scenes at the disaster in which three trains were involved on Wednesday, 3th October, 1952, but to record the effect on the telephone service, the steps that were taken to restore and augment telephonic communications at the station, and to provide lines for all the services involved.

The accident happened at 8.19 a.m., and between 8.20 and 8.30 a.m. nine emergency calls for Police, Fire and Ambulance were received on the Harrow auto-manual board; the load on the automatic equipment rose to 50 per cent. above normal.

Although the full seriousness of the situation was not immediately apparent, the North-West Area Telephone Manager directed that an inspection of the telephonic plant at the station be made, and appointed an official of the Area to act as Incident Officer on site.

The Call Offices in the booking hall and the station yard were in working order, although there were long queues at each. The leads serving the extensions from the railway switchboard to the booking office were severed when the covered footbridge over the railway was carried away. As the instruments of these extensions were not required, they were moved and used with two others for the Emergency Control Office established by the railway officials on the "up-slow" platform. In co-operation with railway engineers the wires for these lines were run over the platforms and under six tracks to a nearby pole. It should be recorded that private subscribers and local business firms willingly gave up their lines, which were diverted for use until spare line plant was proved through.

The Police established an information centre in a motor showroom opposite the station and, before noon, lines were provided for this centre.

Kiosks already assembled were conveyed on a kiosk trailer to the site and erected during the morning in the station yard, and by 1.30 p.m. the first call from one of them was made by a newspaper reporter. A considerable amount of ingenuity and resourcefulness was displayed by the local staff in the provision of floors and lighting for the temporary kiosks, and a local firm was most helpful in providing sundry electrical fittings for the lighting. During the afternoon a further kiosk was erected outside Wealdstone Post Office, and additional lines were provided to Wealdstone Police Station and Harrow Hospital. Lines were also provided for the B.B.C. for the television broadcast from the scene of the disaster the same evening.

Throughout the day traffic was heavy in the neighbourhood of the disaster, particularly at Harrow, Byron, Hatch End and Watford exchanges. Harrow auto-manual board received, altogether, 15 emergency calls. Congestion occurred on Harrow auto-plant at intervals throughout the day, and was worst between 11 and 11.30 a.m. There was fortunately no serious delay. Ticketed calls on the manual board were 3,216 for the day, about double the normal.

On Thursday, 9th October, 1952, the information centre was closed and lines intercepted to divert callers to Wealdstone Police Station. Additional kiosks were erected in the streets adjacent to the station to further relieve the situation. In all, 6 kiosks and lines, 11 additional separate lines and 2 B.B.C. circuits were provided.

The incident, by its nature, had an immediate impact upon the staff of all divisions of the Area. It called for flexibility, initiative and co-operation from those who found themselves engaged in handling the heavy traffic which resulted, and in providing the emergency circuits which were needed. The response of the staff was all that could have been desired; without exception they worked to the limit without demur and went out of their way to provide not only the essentials, but also to ensure that the job they did was the best possible in the circumstances.

G. W. G. L.

South Western Region

PAIGNTON POST OFFICE LIGHTING INSTALLATION

An increasing interest is being shown to-day in the quality and quantity of lighting to be provided over the counters at public offices. The use of "team-working" boards has made the provision of lighting from general sources difficult because of the shadows cast by these boards.

A number of attempts to light the counter from local sources have been made, or are in progress. Most of the schemes favour fluorescent lighting. One such installation has recently been installed at Paignton Post Office. This office has been completely rebuilt inside. A new counter approximately 60 ft. long was constructed. The lighting over this counter was



PAIGNTON POST OFFICE LIGHTING.

contained and completely concealed in a hollow beam which was built down from the ceiling. From the edge of this beam a continuous perspex "team-board," suitably engraved, was hung. The fluorescent lighting is by 5-ft. 80W lamps of the "instant-start" type in standard fittings. The fittings are housed inside the beam, the insides of which are painted white. The bottom of the hollow beam is fitted with flat opal glass to diffuse the light.

The general lighting is of conventional form, except that the fittings were chosen to harmonise with the architect's designs. A continuous writing desk is fitted, along one wall opposite the counter, for the use of the public. This desk is illuminated by spherical bracket fittings of modern design. These harmonise very well with the interior decorations, and can be recommended for any building of modern design.

The lighting obtained on the counter exceeds expectations, both as to quality and quantity. The general impression one



THE COUNTER LIGHTING INSTALLATION.

receives is that the counter is floodlit by natural daylight. The source of the light is not apparent, and this enhances the pleasurable effect one receives on seeing the brightly lit public counter.

One recurring source of trouble in most offices is the illumination of the money-order position. By reason of its box-like construction it is difficult to obtain satisfactory illumination during the daytime; Paignton Post Office is no exception. However, with the type of lighting now installed satisfactory illumination is obtained in daylight hours by the use of one or two of the fluorescent lamps.

It is found that the general lighting adds a warmth to the office lacking in normal daylight hours and, for that reason, a

good argument exists for using fluorescent and filament lighting side by side. The staff, however, complained of the change in colour values produced by the two systems, consequently the filament lighting on the staff side is not normally brought into use.

The installation of this work called for considerable skill and ingenuity on the part of the local staff who carried it out, and thanks are due to them for a lighting installation which was very well installed under difficult conditions.

A. W. B.

NORTH DEVON AND WEST SOMERSET FLOOD DISASTER

The flood havoc of Lynmouth and Exmoor areas will linger long in the memory of many by the suffering it wrought on the peaceful countryside without warning.

The first indication that something serious had happened to Post Office plant was given by a prompt alarm from Lynton exchange at about 9 p.m. Friday, 15th August. Incidentally, the maintenance Technical Officer had to pass through floods to reach the exchange, where he remained until the early hours of the morning. During the night, circuits continually going faulty had to be plugged out and finally the Barnstaple-Lynton C.J. cable, the only link between Barnstaple and Lynton, failed. Jointers were quickly on the scene, but were handicapped by heavy rain, floods and lightning. By herculean effort service was partially restored by 2 p.m. on Saturday, 16th August, and fully restored by 11 p.m. the same day.

The flood water in its fury took with it two kiosks, duct and cable, two carriageway jointing chambers, poles and wires.

Fortunately, the telephone exchange for the area, a U.A.X.14, is situated in Lynton, high above Lynmouth, and far away from the danger of flooding, Lynmouth being connected by underground cables.

Restoration of service, to those subscribers who by good fortune had not lost their homes, was provided by means of aerial cable suspended across the swollen river. The stores and equipment for the work had to be manhandled up and down Lynmouth Hill, a 1 in 4 gradient. The difficult task of getting poles across the flooded river was made easier by help from a military heavy vehicle using a winch and steel hawser to pull the poles across.

In addition to the restoration work, demands were made for circuits by the various organisations set up to deal with the emergency.

Damage to telephone plant in West Somerset was confined to the town of Dulverton, a small township on the fringe of Exmoor in the Exe Valley. Here the flood waters of the River Barle carried away part of the road and 40 yards of duct, leaving three cables cut and damaged beyond repair, isolating a U.A.X.12, Anstey Mills, and subscribers' lines south of the town.

Restoration in this case was by interruption cable laid over the surface away from the damaged road. The work was completed by 2.30 p.m. Saturday, 16th August, 1952.

H. R. R.

"MASON" BEES' NEST IN KIOSK TELEPHONE

In an organisation such as the Post Office Telephones, with plant in almost every corner of the country, unusual things are bound to happen. At Rampisham, a small Dorset village in the Taunton Area, "Mason" bees (wild bees known by the manner in which they nest) built their home in the local Post Office Kiosk telephone. The "Mason" bee uses particles of sand which it mixes with saliva to form cells where it stores quantities of pollen and breeds its young. The bees are black, much smaller than the honey bee and do not live in large colonies; they are really solitary bees.

From early spring the Sub-Postmaster, a well-known Dorset beekeeper, had many complaints about bees being in the telephone kiosk and after explaining they were not honey bees, but busy little "Mason" bees going harmlessly about their business, searched in vain to find their nest. It was not until late summer that the mystery was solved, when a fitter changing over the

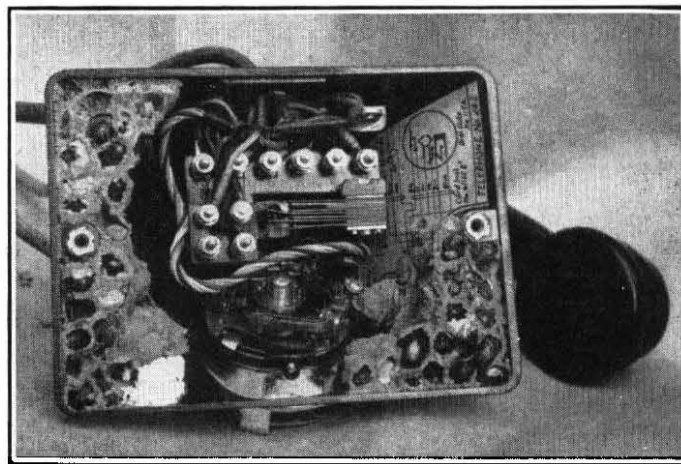

BEES' NEST IN TELEPHONE INSTRUMENT.

telephone for transfer from U.A.X.5 to U.A.X.13 found the bees had built their nest inside the telephone. The cells had been formed around the inside of the bakelite shell leaving the spring assembly, connecting points and dial mechanism completely clear. The cord hole at the rear of the telephone had been used as the entrance.

H. R. R.

Home Counties Region

MANHOLE EXCAVATION AND CONSTRUCTION WITH THE AID OF DEWATERING SYSTEM

During recent contract ductwork in the Portsmouth Area a section of track between Havant and Emsworth had to be laid within a short distance of the sea. The existing jointing chambers were surface boxes and, when excavations were made to provide manholes, very wet running sand was encountered at varying depths from 3 ft. Efforts were made to excavate the manholes with the aid of double close shuttering without much success, while at one hole the timber would not remain in an upright position but shifted laterally as much as 2 ft. The running sand continually "boiled up" at the bottom of the excavation, leaving voids behind the timber. As the manholes were situated on the main A 27 road from Portsmouth to Brighton, this constituted a danger to traffic, there being a possibility of the road subsiding.

It was decided to employ dewatering plant, using the well points recently issued to the Area. Norwich Area supplied a "header" pipe with three "Y" pieces. Owing to the gravel nature of the soil, it was not possible to sink the well points with a Pegson pump and a type with a greater pressure was required; a suitable pump giving this requirement was a Beresford Stork trailer pump, using a pressure of about 50 lb./sq. in. Pressure hose had to be employed. It was necessary to provide a reservoir capable of holding 50 to 100 gallons of water for jetting the well points. This was accomplished by digging the manhole to a depth of about 2 ft. 6 in., trenching along each side of the excavation where the well points would be sunk and cutting a gully from these trenches into the main excavation; this enabled the water discharged from the jetting head of the well point to circulate back to the "reservoir" for re-use.

A more satisfactory method for jetting was the use of the local water main supply where adequate drainage was available. The water main provided a pressure of approximately 45 lb./sq. in., which could be varied by adjusting the valve at the hydrant. About 2,000 gallons of water were jetted down the six well points and the local water company made a charge of 1s. 6d. per 1,000 gallons. The cost of sinking the well points for each manhole was therefore a good deal less than that where a pump was used. Five of the seven manholes were jetted by this method. The well points were sunk one at a time and then

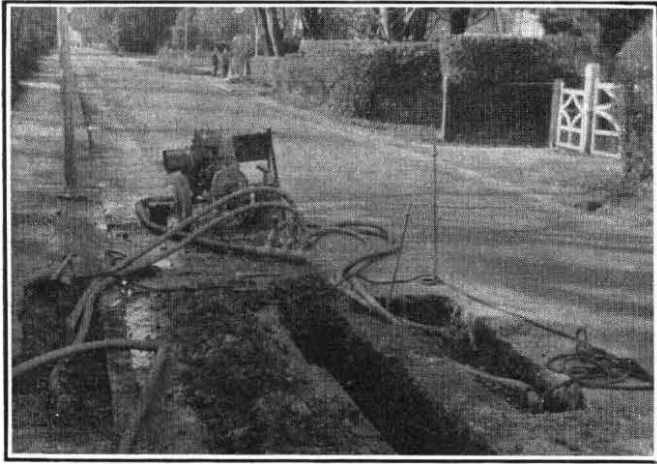

3-IN. SUCTION PUMP IN USE FOR DEWATERING.

connected to the "header" pipe through the "Y" pieces; to this was connected a 3-in. diaphragm pump. After about five minutes' pumping, water was being drawn up each well point and the excavation of the manhole proceeded.

In two excavations no timbering was necessary and in most cases the sand was firm and not unlike soft sandstone.

It was necessary to sink the well points to such a depth that the top of the gauze was at least 6 in. below the bottom of the final excavation, otherwise the bottom portion of the hole was found to be soggy.

The pump was required to run 60 hours continuously and it was found that the diaphragm-type pump driven by a slow-speed petrol engine was most suitable, especially with regard to noise when in a built-up area. The only attention the pump needed was to have its water and petrol tank refilled every eight hours and oil tank very occasionally.

The use of well points extended the time taken to construct a manhole by about one day beyond the time which would have been taken in dry conditions. The manholes dealt with would actually have been impossible to construct by any other means, except by elaborate shuttering methods and in a much longer time than that taken. During the period of time taken to construct the seven manholes, a good deal of experience was gained in the use of dewatering plant and a complete set of equipment, with the exception of a 3-in. diaphragm pump which can normally be supplied by the contractor, has been assembled within the Area for future use.

The types and number of manholes constructed were one R0, five R1A and one R1B.

W. C. J.

Midland Region

EXECUTION OF LARGE DUCT SCHEME BY DIRECT LABOUR

A large duct scheme in the Stoke-on-Trent Area, which forms part of an M.U. route with a large defence content, was of such a magnitude that two, or possibly three, contractors would be employed on it for several months. A proposal was made by the Telephone Manager that, in view of the urgency, a portion of this duct should be laid by direct labour, the portion chosen being in open country where the use of mechanical excavators could be usefully employed.

The portion was several miles in length and fell naturally into three sections. Three working parties were employed, the number of men employed at any time in each party depending on whether mechanical or hand excavation was employed, and the necessity to draw men from the job for other work. The average number of men employed was 30, being deployed between the parties as the work required.

Owing to the presence of two mole-drained cables, one on each side of the road, one of the sections had to be executed completely by hand digging. It had been hoped that excavating

by machine would have been possible in this section, but, due to the irregular route taken by the mole-drained cable, hand digging was eventually resorted to in order to avoid damage to it. The cable was, in fact, damaged several times before hand digging was commenced. The length of track excavated mechanically was just less than 50 per cent. of the total for the job.

Work commenced in mid-January, 1952, and for several weeks was hampered by frost and snow. Two of the sections were along narrow lanes which carried an abnormal number of heavy service vehicles and civilian lorries. It was, therefore, necessary to take strict precautions to ensure that no blockage of the lanes occurred, due to spoil thrown up by the excavator or due to the Department's vehicles.

Full use was made of mechanical aids, and employed on the job were two Aveling Barford trench excavators, one Calf Dozer, one Broomwade compressor and one Benjo Rammer. The trench excavators performed admirably when the soil was suitable, but they had to be discarded in favour of hand digging in places where the clay was very compacted. The Calf Dozer was found to be extremely useful, and the operator (an ex-army driver of tracked vehicles) became an expert at manoeuvring the vehicle and depositing the spoil neatly in the trench without damaging the edge of the grass verge. Under the best conditions with the use of the excavator, a maximum of 165 yards of trench excavated and filled in in one day was achieved.

The location of the work was some considerable distance from the workmen's headquarters; consequently the ineffective time was high. For travelling, the rear portions of Karrier vehicles were fitted with seats so that up to 18 men could be carried on one vehicle. The welfare of the workmen was looked after by the hiring of three contractor-type caravans, each complete with coke stove and lockers.

Taking into account all the adverse factors, the work was carried out in a most expeditious and efficient manner, and the morale of the workmen was high at all times. The costs, including all indirect charges, were only slightly greater than the estimated contract rates, and the staff employed merit praise for the diligence and cheerfulness with which they tackled the job.

H. T. A. E. P.

Wales and Border Counties

RECOVERY OF THE CARDIFF MANUAL EXCHANGES

Following the transfer to the automatic exchange, of which some equipment features were described in the July issue recovery work on the three manual exchanges has proceeded. The C.B.10 relief exchange has been completely dismantled and the premises given up. Work on the C.B.1 local exchange and the sleeve control trunk exchange are well advanced. A good start was made within a week of the transfer by the despatch of two trunk test racks to meet an emergency at Hull.

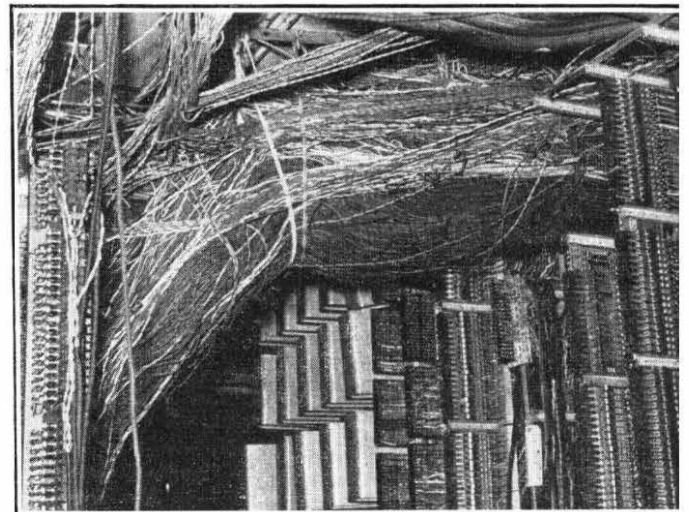

M.D.F. WIRING IN CARDIFF MANUAL EXCHANGE.

The initial portion of the local exchange was installed in 1910 and in the past 40 years a great deal of dust had accumulated in the wiring and runways making necessary the use of masks by the staff carrying out dismantling. Much of the internal cabling was in lead-covered cable and approximately 20 tons will be recovered. The M.D.F. accommodated in the basement has, for a long time, been the object of curiosity. For more than 20 years the expectation of a new exchange has encouraged expedients which have led to a strange accumulation of wiring, some of which is visible in the accompanying illustration.

Great as was the need for the new exchange, the passing of the old is regretted, this sentiment being encouraged by the forlorn appearance of the deserted apparatus and switchrooms. It is, therefore, heartening to record that a large quantity of useful stores have been made available and are being disposed of advantageously.

S. E. N.

AN UNUSUAL POLE RECOVERY

The current spate of dangerous pole renewals often taxes the ingenuity of field staff. In most situations, it is a simple task to erect a new pole near to the decayed one, transfer all circuits and then, using the new pole as a derrick, recover the old.

In urban areas, however, it is generally expedient to provide a much smaller pole to replace the existing one and this, allied to the fact that close proximity of buildings makes recovery difficult, has the effect of making the renewal something of a major operation. One such case is illustrated.

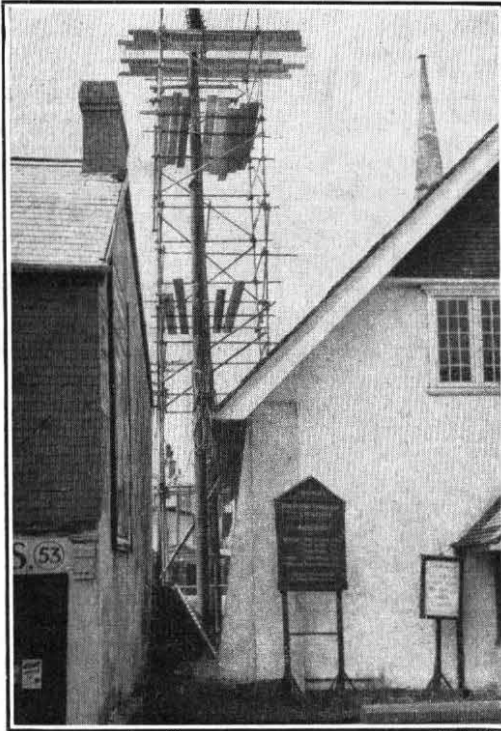

SCAFFOLDING ERECTED FOR POLE RECOVERY.

The pole which had to be recovered was a 55-ft. Stout D.P. of N.T. vintage (1900) in a Swansea suburb. Decay had been accelerated by ingress of moisture at a deep cut made, unknown to the Department, to accommodate an adjacent church guttering.

The pole had been found on test to be practically hollow from the incision down to and below ground level. This made the pole very unsafe for climbing without considerable temporary staying and stiffening by lashing another pole to it. Temporary stays were impossible to site, so the expedient of scaffolding was adopted. The scaffolding was erected by a local firm and cross-members inserted to hold the pole in a vertical position.

By working on the top platform, wiremen removed the existing wires, working circuits having previously been cut into interruption cable near the foot of the pole. The pole was cut down in sections to approximately 12 ft. from the ground, the scaffolding then dismantled, and finally the remainder of the pole was jacked out of the ground.

The subsequent work of permanent wiring to the subscriber's premises was, of course, just normal practice.

A. J. C.

North Eastern Region

MOOTH EGGS IN U.A.X. 7A UNIT

A U.A.X. 7A unit recently received from the Supplies Department, for an extension at Boston Spa Exchange, was found, on removal from its case, to be infested with eggs, live grubs, and chrysalises of the clothes moth (*linea pellionella*). The eggs were in clusters on cable forms, bank wiring, in crevices and ledges inside the framework, and actually under insulation stuck to the unit. Dead moths were found inside covers and liberally scattered throughout the unit. There was, however, no evidence of damage to the wiring and in view of the short supply of the item it was decided, following consultation with the Engineering Department, that steps should be taken locally, to get the unit fit for service.

Enquiry was made of the Leeds Public Health Department, Disinfection Centre, who recommended the following treatment, as the only effective remedy for the destruction of moth eggs.

The unit should be placed in a special sealed chamber and the temperature raised by means of heaters to 86°F. 1 lb. of Hydrogen Cyanide (prussic acid HCN) to every 500 cu. ft. of equipment is then poured into a special container, external to the chamber, and the temperature of this raised to a level which would allow gas to be given off and injected into the chamber. The boiling point of HCN is 26°C or approximately 79°F, therefore, when the gas enters the chamber the temperature inside maintains the hydrogen cyanide in a gaseous form. The equipment should be left under these conditions for 48 hours.

The temperature of the chamber permits the eggs to hatch and the gas will then kill the grubs, but even should they not hatch, the penetrating power of the gas is sufficient to break through the shell of the egg and thus effectively despatch it. As a matter of interest hydrogen cyanide gas will penetrate a brick wall to a depth of 4 in.

At the end of 48 hours the gas is extracted by fan to the atmosphere where it is quite harmless. The equipment should remain for a further 48 hours to ensure that all trace of gas has been removed.

It was learnt that similar treatment had often been given to wireless sets, musical instruments, etc., and no detrimental effects had been reported.

After further discussion it was decided that the method should be adopted, but that all handling of the equipment should be done by the Department. It was discovered that two felt strips from the side of the unit, which had attracted the moths in the first place, and under which a number of eggs were found, had been left in the packing case; therefore it was decided that the case should be treated at the same time as the unit.

After treatment, inspection revealed that a thin deposit of greyish coloured powder coated a number of metallic parts, particularly the relay armatures. The powder was understood to be a deposit of hydrogen cyanide, and in this form was quite harmless. It was readily removed, and arrangements made for all metallic parts to be cleaned with carbon tetrachloride.

The cost of carrying out the disinfection of unit and packing case was £5. Added to this of course was the time spent in collecting and returning the equipment and also in cleaning.

As the only alternative would have been a complete re-wiring, thorough cleaning of the unit, and possible destruction of the case a considerable saving has been achieved.

T. H. W.

FARMERS' "SELF-HELP" SCHEME

On 14th October, 1952, the Lincoln Area connected up the first "Self-Help" Farmer to be given service in the country. This Area is very rural and as soon as the scheme was announced, enquiries were made of long-waiting farmers and the first one to benefit from the scheme is Mr. Norris of Mill Farm, Woodhall Spa.

Mr. Norris has set a very high standard for farmers to follow although it should be said that he has more than a passing knowledge of electrical engineering and in that respect has an advantage over many other farmers. The photograph gives some idea of his construction which was done without any on-site aid or supervision from this Department and, except for "storm" damage, he should enjoy trouble-free service for a very long time.

For the construction work he used a mile of Cable I.R.V., B. & C. purchased from the Department, 80 4-ft. fencing stakes, 2 20-ft. poles to give clearance across the farmyard gate, bobbin insulators and sundry items. For his lead-in he made his own "Spikes, Spiral, Eye" which are most effective. His method of binding in at the bobbin insulators is good; he first bound the cable with adhesive tape for a length of 6 in. then wound soft copper wire over it and around the insulator.

On completion he "meggered" his line (with his own megger) and "reported" an I.R. of 20 megohms. Within 2 days of his completing the work, he was given service and the Department had been saved erecting 24 poles and 1,500 yds. of loop wire.

In this case we can say with certainty that we have one satisfied "Self-Help" customer and we hope the numerous others who are hoping to follow Mr. Norris's lead will all feel the same.

J. W. S.

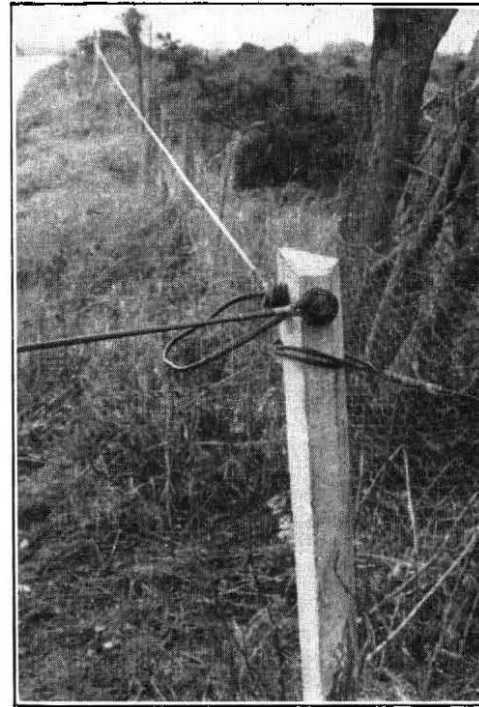

THE LINE SUPPORTED AT STAYED ANGLE POST.

Associate Section Notes

Carlisle Centre

The Annual General Meeting of the Centre was held on 8th April, 1952, when the following officers were elected for the year 1952/1953:—

President, L. A. Triffitt, B.Sc., A.M.I.E.E.; *Chairman*, G. H. Wood; *Secretary and Treasurer*, W. A. Harper; *Dty. Chairman*, F. Roberts; *Dty. Secty. and Librarian*, H. B. Coulthard. *Committee*: P. M. Scott, H. R. N. Iniff, J. Hammond, A. Whittaker, P. Hurson, G. Priestley, J. T. Harrison. *Hon. Auditors*: H. R. N. Iniff, A. Wilson.

During the summer a visit was made to the Scottish Hydro-Electric Scheme at Loch Sloy, and also a visit to the "Solway Colliery" at Workington.

The programme for the remainder of the season is as follows:—

13th January.—"Photography," by Mr. R. Cleaver.

10th February.—"Telegraphic Switching," by Mr. H. Litt.

10th March.—"Gardening," by Mr. Irving, F.Ins.P.A., F.R.H.S., Carlisle Corporation Parks Superintendent.

14th April.—Annual General Meeting. W. A. H.

Edinburgh Centre

After several years' hibernation, the Edinburgh Centre of the Associate Section has reawakened. A good start to the session was given by Col. Calvey, O.B.E., who gave an interesting and provocative talk on "Appraisalment and Promotion" on the 7th October. Mr. Hines, the Chief Regional Engineer, was in the chair. At this meeting a committee was elected to carry on the good work, and they have arranged a varied programme of papers for the remainder of the session. Visits to places of interest are also being arranged, full details of which will be announced as soon as possible.

At the second meeting, held in the G.P.O. Dining Room Annex on 13th November, Mr. J. K. W. Munro, of the Regional Training School Staff, gave an excellent survey of "Engineering Training." The lively discussion which followed was only curtailed by the inevitable march of time.

The Area Engineers, Mr. J. W. Branson and Mr. G. Bealby, have consented to be Joint Honorary Presidents of the Centre. The other office bearers for the session are:—

Chairman, J. H. S. Phillips; *Secretary*, S. R. Haggart; *Treasurer*, D. V. Findlay; *Librarian*, F. C. Baker.

Dundee Centre

The opening meeting of the 1952/53 Session was marked by an afternoon visit to Leuchars Aerodrome on Saturday, 31st August, 1952, where we were shown the R.A.F. system of "Air Communications" and the co-operation with the Post Office was explained.

On the 5th September, 1952, members of our Committee were present at a prize-giving ceremony for work at Technical College, for which this Centre had been one of the donors. A number of prizes were presented by Col. Gardiner, the Regional Director, who, in his speech, outlined the opportunities to be gained by further education. It is our hope that a gesture of this kind will help stimulate interest in further education.

On the 30th September, 1952, Chief Inspector Smith, of the Dundee City Police, gave a stimulating illustrated lecture on "Road Traffic Problems," which provoked much discussion.

On the 21st October, 1952, a visit was made to the local R.O.C. headquarters, where an enlightening demonstration of the R.O.C. network with its reference to the Post Office was given.

The remainder of the programme for the session is as follows:—

January.—"Outline of Electronic Switching Methods."

Mr. N. T. C. McAffer.

February.—Visit to a local engineering works.

March.—A.G.M. and Film Show.

R. L. T.

Glasgow and Scotland West Centre

The Glasgow and Scotland West Associate Section of the I.P.O.E.E. has held two meetings this session.

The opening meeting consisted of a Film Show, comprising (1) "Precise Measurement for Engineers"; (2) "Radar"; and (3) "Robinson Charlie" (a cartoon on production distribution and consumption).

The second meeting proved a lively night, when our Chairman, Mr. R. F. B. Bucknall, formerly T.M. Scot. West., gave a very interesting address on "Men and Money within the Post Office." The Vice-Chairman had to put a time limit to the discussion because of the interest shown!

The next meeting is a visit to the new Braehead Power Station at the end of November, and this will be reported on in a later note.

The Centre wishes to record its appreciation of the services rendered by its Chairman and takes this opportunity of wishing him success in his new post as Telephone Manager, Edinburgh Area.

It is pleasing to report that the officers of this Centre have been asked to assist in the formation of a new Centre at Hamilton.

J. F.

Birmingham Centre

The change of title to "Associate Section" has been welcomed here, as it has been felt for a long time that "Junior Section" was a misnomer. This Centre has been active over the past two years in campaigning for the change and would like to offer its thanks to Mr. Taylor, the Midland Region Liaison Officer, for pursuing the matter at the annual conference held by these Officers, and to all others in authority who have brought this matter to a successful conclusion.

The visit to the Locomotive Works of British Railways at Crewe on Sunday, 17th August, proved very interesting to the 24 members who participated. Reserved accommodation on trains in both directions was arranged and the journeys were most comfortable. Unfortunately, our arrival at Crewe was behind schedule owing to a delay caused by work being carried out on the permanent way entailing single-line working. A sandwich lunch was eaten in a park which, according to our guide, was "the best park in the North of England"—it was, and a nice walk, too; ask any of those who went!

Coinciding with the opening talk of the session, given by the Deputy Telephone Manager, Mr. S. H. Croft, on 17th September, the membership of this Centre reached the figure of 200. A most enjoyable evening was spent hearing in some detail of the work carried out by the Sales, Traffic and Clerical Divisions of the Telephone Manager's Office, and question time cleared up a number of doubtful points in the minds of those present. The most recent talk was that given by Dr. A. M. Uttley, of T.R.E. Malvern, on "Digital Computing." This being quite an involved subject, only the briefest outline could be given in the time available. Nevertheless, all members present agreed that the evening was well spent.

On both these occasions the attendance was just under 30 and an experiment of providing tea and cakes for half an hour prior to the opening of each meeting was welcomed by those present.

Visits to both the B.B.C. Television Transmitter at Sutton Coldfield and the Theatre Royal (to see the stage and electrical gear) have proved so popular that additional visits have had to be arranged to accommodate all those wishing to attend.

The programme arranged for the second half of this session is as follows:—

8th January.—"Plastics."—W. E. Pattman, of Bakelite, Ltd.

10th January.—Visit: I.C.I. Chemical Works, Oldbury.

21st January.—"Inter-Planetary Travel."—A. C. Rotherham, Treasurer of Birmingham Centre.

10th February.—Visit: City Museum—Archæological Dept.

16th February.—"Cable Corrosion and Protection."—F. A. A. Pariser (Assistant Engineer, Birmingham Centre).

11th March.—"Amplifiers."—J. S. Kendall, member of Birmingham Centre.

24th March.—Visit: Austin Motor Works.

14th April.—"Television Outside Broadcasts."—Barrie Edgar, of the B.B.C. Midland Region.

18th April.—Visit: B.B.C. Engineering Training School, Evesham.

23rd April.—Annual General Meeting.

It is hoped that members will bring to the A.G.M. sufficient ideas for talks and visits to enable another good programme to be compiled for the next session. Remember that your Officers

and Committee do all they can to provide you with the sort of programme you want—support them in their efforts and let them know just what you do want.

K. G. S. A.

Bradford Centre

The Centre, though off to a late start, has been given enthusiastic support. A proposition at the Annual General Meeting to have subscriptions deducted from pay at 1d. per week was adopted and has been most successful; we have the highest number of members ever in this Centre.

A full programme has been arranged with a meeting each month until the Annual General Meeting and Film Show in June, 1953. The programme includes visits to wire and textile mills, an electric motor works, an iron foundry, and a day visit to Liverpool Docks. Details are being circulated to members.

There is a growing interest in the library and it is hoped to improve this facility by having extracts from the catalogue printed locally.

E. A.

Middlesbrough Centre

On the 20th September, the Middlesbrough Centre and their friends were fortunate in having a most interesting Film Show in a local cafe. Travel films featuring South America were shown and commented on by Mr. Bevan Pumphrey, who gave us an insight into the pleasures and mysteries of that interesting continent. A hearty vote of thanks showed how much the Centre appreciated the evening.

The Centre had to say farewell with regret to Mr. J. S. Gill, our Area Liaison Officer—a change of duty necessitating this. We welcome Mr. J. N. Parker as our new Liaison Officer and rely on his full co-operation in Centre affairs.

The Section President, Colonial Calveley, paid the Darlington Centre a visit, and Middlesbrough Centre joined forces at Darlington to hear a most interesting and well-received address. His very controversial subject, "The Present System of Appraisal and Promotion," caused considerable discussion.

Mr. G. Dale, a Darlington colleague, on the 6th November gave us a talk on "An Outline of Multi-Metering in Non-Director Areas." This informative lecture covered all aspects of multi-fee metering in the non-director auto area, and caused much interest.

Our attendances were maintained, but we hope that those who do not yet take advantage of the Centre facilities will do so in the near future. Budding lecturers should note our Telephone Manager's offer of one guinea for the best lecture given in the Area during the current session.

J. B.

Darlington Centre

The following programme for the remainder of the 1952/53 session is offered in the hope that its varied nature will attract members of *all grades* to attend the meetings.

6th January.—"Local Government," H. Hopkins, Town Clerk, County Borough of Darlington.

3rd February.—"Income Tax—from the Underside," E. J. L. Hochstrassen (District Inspector), H.M. Inspector of Taxes.

12th March.—"Two-Way Quiz," Darlington v. Middlesbrough.

24th March.—"Shared Service," A. Chapman and E. R. Trotter.

22nd May.—Annual General Meeting.

On the 8th October, the Centre got off to a good start of the session by the visit of the Section President, who was greeted by a representative gathering (70). Colonel Calveley's talk proved to be most interesting and controversial and in the discussion which followed there was no lack of questions. The vote of thanks to the President was proposed by Mr. E. Pinkney and seconded by Mr. D. Paterson (Chairman, Middlesbrough Centre).

On Saturday, 18th October, 30 Centre members journeyed by bus to Arncliffe Television Relay Station. Mr. J. Ainsley (T/O on duty) conducted the party round the station and explained the purpose of the station and described the apparatus and operation.

These outdoor visits are proving to be extremely popular.

C. N. H.

Staff Changes

Promotions

Name	Region	Date	Name	Region	Date
<i>Staff Engr. to Deputy Director</i>			<i>Tech. Offr. to Asst. Eng.—continued.</i>		
Booth, Capt. C. F.	E.-in-C.O. to External Telecomms. Executive.	21.7.52	Williamson, G. C.	L.T. Reg. to E.-in-C.O.	23.10.52
<i>Area Engr. to Telephone Manager</i>			Preece, J. R.	S.W. Reg. to E.-in-C.O.	15.11.52
Gill, W. E.	W.B.C. Reg. to Mid. Reg.	15.9.52	Machent, H.	E.-in-C.O.	24.11.52
<i>Exec. Engr. to Senr. Exec. Engr.</i>			<i>Tech. Offr. to Asst. Exper. Offr.</i>		
Reeves, L. N.	E.-in-C.O.	8.9.52	Hardcastic, R. A.	E.-in-C.O.	8.9.52
Twycross, A. E.	Mid. Reg. to N.E. Reg.	20.10.52	<i>Tech. Asst. II to Tech. Asst. I</i>		
Whittingham, L.	W.B.C. Reg.	29.9.52	Booth, A. W.	E.-in-C.O.	16.8.52
<i>Asst. Engr. to Exec. Engr.</i>			<i>Technician IIA to Asst. (Sc.)</i>		
Lavender, E. W.	L.T. Reg.	24.9.52	Belcher, P. L.	E.-in-C.O.	11.10.52
Hughes, J. A.	L.T. Reg.	24.9.52	<i>Asst. (Sc.) to Asst. Exper. Offr.</i>		
Lester, T.	N.W. Reg.	22.10.52	Keen, D. S.	E.-in-C.O.	11.10.52
Douglas, A. S.	W.B.C. Reg.	20.11.52	Coots, E. J.	E.-in-C.O.	11.10.52
<i>Tech. Offr. to Asst. Engr.</i>			May, R. J.	E.-in-C.O.	1.9.52
Cable, H. W.	E.-in-C.O.	20.8.52	<i>Asst. (Sc.) to Asst. Traffic Supt.</i>		
Tutton, W. F.	E.-in-C.O.	27.9.52	Brown, B. M.	E.-in-C.O. to L.T. Reg.	2.10.52
Kingswell, L. W.	L.T. Reg. to E.-in-C.O.	27.9.52	<i>Mechanic I/C I to Tech. Asst. II</i>		
Nelson, J. M.	E.-in-C.O.	27.9.52	Bell, D. H.	H.C. Reg.	8.10.52
Johnson, N. G.	L.P. Reg. to E.-in-C.O.	27.9.52	<i>Mechanic I/C II to Tech. Asst. II</i>		
Hoare, H. V.	L.T. Reg. to E.-in-C.O.	14.10.52	Entwistle, F. C.	N.W. Reg.	8.10.52
Baugh, T. H.	Mid. Reg. to E.-in-C.O.	22.10.52			
Williamson, H. M.	E.-in-C.O.	25.10.52			
Hearn, A. F. L.	L.T. Reg. to E.-in-C.O.	25.10.52			
Eveling, I. H.	L.T. Reg. to E.-in-C.O.	25.10.52			

Transfers

Name	Region	Date	Name	Region	Date
<i>Chief Reel. Engr.</i>			<i>Asst. Engr.—continued.</i>		
Smith, W. F.	N.E. Reg. to E.-in-C.O.	20.10.52	Mangan, D. P.	E.-in-C.O. to S.W. Reg.	15.10.52
<i>Senr. Exec. Engr.</i>			Forty, A. S.	L.T. Reg. to H.C. Reg.	1.7.52
Swain, E. C.	E.-in-C.O. to L.T. Reg.	6.10.52	Kerr, A. S. H.	E.-in-C.O. to Scot.	1.11.52
<i>Asst. Engr.</i>			Allchin, M. C. V.	E.-in-C.O. to H.C. Reg.	16.11.52
Stears, A. D. S.	E.-in-C.O. to Scot.	7.9.52	Budd, D. A.	H.C. Reg. to P. & T. Dept., Nyasaland	2.10.50
Gosling, J. C.	Mid. Reg. to Min. of Civil Aviation	1.9.52	<i>Asst. (Sc.)</i>		
Smith, R. E.	E.-in-C.O. to Min. of Civil Aviation	1.9.52	Turner, F. T.	E.-in-C.O. to Admiralty	20.10.52
Ray, M. A.	E.-in-C.O. to L.T. Reg.	6.10.52	<i>Draughtsman</i>		
Michie, P. G.	E.-in-C.O. to Scot.	5.10.52	Tebbs, H. F.	E.-in-C.O. to Gov. Communications H.O.s	1.11.52

Retirements

Name	Region	Date	Name	Region	Date
<i>Area Engr.</i>			<i>Asst. Engr.—continued.</i>		
Coote, F.	S.W. Reg.	24.11.52	Summerlin, S. C.	E.-in-C.O.	29.11.52
<i>Exec. Engr.</i>			Mackellar, A. C.	E.-in-C.O. (Resigned)	31.10.52
Brooke, C. H.	L.T. Reg.	5.10.52	Best, A. S.	E.-in-C.O. (Resigned)	31.10.52
<i>Asst. Engr.</i>			<i>Inspector</i>		
Granger, S. B.	E.-in-C.O.	30.9.52	Devan, H.	Scot.	27.8.52
Luck, L. A.	S.W. Reg.	30.9.52	Manson, J. W.	Scot.	23.8.52
Outhwaite, W.	N.E. Reg.	30.9.52	Rowlands, T. L.	L.T. Reg.	20.9.52
Booth, G. W.	N.E. Reg.	21.9.52	Miller, J. W.	Mid. Reg.	5.10.52
Nicoll, G. F.	N.E. Reg.	19.10.52	Morris, W. P.	L.T. Reg.	14.10.52
Griffiths, M.	Scot.	31.10.52	Austin, T. W.	N.W. Reg.	15.10.52
Kelley, G. T.	L.T. Reg.	22.11.52	Hardy, F. G.	L.T. Reg.	8.8.52
Blyth, W. J.	L.T. Reg.	31.10.52	Manning, J. R.	H.C. Reg.	31.8.52
Hodgkinson, H.	N.E. Reg. (Health grounds)	17.11.52	Sparkes, A. E.	H.C. Reg.	18.8.52
			Given, R. S.	Scot.	20.9.52
			Watson, P. A.	Mid. Reg.	2.1.52

Deaths

Name	Region	Date	Name	Region	Date
<i>Asst. Engr.</i>			<i>Asst. Engr.—continued.</i>		
Edmonstone, J. M.	Scot.	9.8.52	Parry, J.	W.B.C. Reg.	6.11.52
Markey, J.	N.E. Reg.	14.9.52	Papps, E. G.	L.T. Reg.	12.11.52
Mvors, E.	N.W. Reg.	4.10.52			

Post Office Electrical Engineers' Journal

Volume 45, April 1952—January 1953

INDEX

A	PAGE NO.	F	PAGE NO.
Air Compressors for External Works	5	Fault Recorder or Docket Printing Machine, The	115
Approach to the Standard Equations for a Uniform Transmission Line, An		Fielding, H., and E. C. Swain. Telecommunication Problems arising from Hydro-Electric Schemes in Scotland	104
Part 1.—Propagation of Current and Voltage in a Chain of Symmetrical Resistance Networks.	30		
Part 2.—Propagation of Current and Voltage in a Chain of Impedance Sections, Simulating the Uniform Transmission Line	80	G	
Archbold, R. B. An Experimental Probe Microphone for the Measurement of Sound Pressures	145	Gantry, Transportable, A 30-cwt	174
Associate Section Notes	45, 88, 136, 186	Gas Discharge Tube for Line Protection, An Improved	108
Automatic-Scanning Receiver for Radio Monitoring, An	149	Green, L. New-Type Routiners for Automatic Telephone Exchange Equipment	19, 61
Automatic Telephone Exchange Equipment, New-Type Routiners for	19, 61		
B		H	
Barrett, L. W. The Use of Explosives in External Operations	52	Harbottle, H. R. An Approach to the Standard Equations for a Uniform Transmission Line	30, 80
Bates, A. W. Test Equipment for the London Centre of the C.C.I.F. Field Trials of International Semi-Automatic Telephone Operation	165	Haworth, J. E. A Millisecond Timing Unit	25
Billinghurst, F. M., F. J. Lee and F. J. M. Laver. An Automatic-Scanning Receiver for Radio Monitoring	149	Hydro-Electric Schemes in Scotland, Telecommunication Problems arising from	104
Bomford, K. D. Thermal Problems of Small Underground Installations	14		
Book Reviews	24, 29, 34, 57, 67, 76, 84, 86, 96, 103, 114, 119, 124, 133, 140, 148, 159, 171, 177, 178, 179	I	
Bray, W. J., and D. W. Morris. Single-Sideband Multi-Channel operation of Short-Wave Point-to-Point Radio Links. Part 1	97	Improved Gas Discharge Tube for Line Protection, An	108
Bray, W. J. The Detection of Television Receivers	49	Institution of Post Office Electrical Engineers	87, 135, 180
Broadcasting Conference, Stockholm, 1952, The European V.H.F.	132	Instrument for Testing Subscriber's Sets <i>in Situ</i> , An	129
		Interference from Cathodic Protection Rectifiers	68
C		International Semi-Automatic Telephone Operation, C.C.I.F. Field Trials of	120, 160
Cables, Telephone, New Methods of Locating Faults in	77	International Semi-Automatic Telephone Operation, Test Equipment for the London Centre of the C.C.I.F. Trials of	165
Cardiff Non-Director Automatic and Zone Centre Trunk Exchange	58		
Cathodic Protection Rectifiers, Interference from	68	J	
C.C.I.F. Field Trials of International Semi-Automatic Telephone Operation		Joint, A New Coaxial Cable	1
Part 1.—Signalling and Switching Principles	120	Joints for Coaxial Pairs, Reflectionless	72
Part 2.—Facilities to be Provided	160	Jones, F. An Improved Gas Discharge Tube for Line Protection	108
C.C.I.F. Field Trials of International Semi-Automatic Telephone Operation, Test Equipment for the London Centre of the	165		
C.C.I.F. Meetings, Florence, October, 1951	35	L	
Chick, P. G. S. A Postal Order Printing and Issuing Machine	11	Latimer, E. D. A New Coaxial Cable Joint	1
Coaxial Cable Joint, A New	1	Laver, F. J. M., F. M. Billinghurst and F. J. Lee. An Automatic-Scanning Receiver for Radio Monitoring	149
Coaxial Pairs, Reflectionless Joints for	72	Lee, F. J., F. J. M. Laver and F. M. Billinghurst. An Automatic-Scanning Receiver for Radio Monitoring	149
Cobbe, D. W. R. Interference from Cathodic Protection Rectifiers	68	Line Plant Network Diagrams, The Colour Printing of	83
Colour Printing of Line Plant Network Diagrams, The	83	Line Protection, An Improved Gas Discharge Tube for	108
Combining Unit for Superimposing Two Television Pictures on the Same Cathode Ray Tube, A	172	Lipscombe, C. D. The Colour Printing of Line Plant Network Diagrams	83
Compressors for External Works, Air	5		
D		M	
Detection of Television Receivers, The	49	Mellor, S. D. A Method of Assessing the Effect of Flexibility in Distribution Networks	125
de Wardt, R. H. An Instrument for Testing Subscriber's Sets <i>in Situ</i>	129	Method of Assessing the Effect of Flexibility in Distribution Networks, A	125
Distribution Networks, A Method of Assessing the Flexibility in	125	Miles, J. V. C.C.I.F. Field Trials of International Semi-Automatic Telephone Operation	120, 160
Docket Printing Machine, The Fault Recorder or	115	Millisecond Timing Unit, A	25
		Moffatt, J. J. Air Compressors for External Works	6
E		Morris, D. W., and W. J. Bray. Single-Sideband Multi-Channel operation of Short Wave Point-to-Point Radio Links. Part 1	97
European V.H.F. Broadcasting Conference, Stockholm, 1952, The	132		
Ewen, A. B., and F. C. Owen. Single-Sideband Multi-Channel Operation of Short-Wave Point-to-Point Radio Links.—Part 2	154	N	
Experimental Probe Microphone for the Measurement of Sound Pressures, An	145	New Audio-Frequency Oscillator (Oscillator No. 22), A	111
Explosives in External Operations, The Use of	52	New Coaxial Cable Joint, A	1
Extraordinary Administrative Radio Conference, Geneva, 1951, The	85	New Methods of Locating Faults in Telephone Cables	77
		New, S. E. Cardiff Non-Director Automatic and Zone Centre Trunk Exchange	58
		New-Type Routiners for Automatic Telephone Exchange Equipment:	
		Part 2.—General Description of the Control Circuit	19
		Part 3.—Circuit Principles of Test Relay Sets and Common Test Relay Sets	61
		Notes and Comments	39, 87, 135, 180
		Notes, Associate Section	45, 88, 136, 186
		Notes, Regional	40, 90, 137, 181

O	PAGE NO.
Oakford, E. R. New Methods of Locating Faults in Telephone Cables	77
Oscillator, A New Audio Frequency, (Oscillator No. 22) ..	111
Owen, F. C., and A. B. Ewen. Single-Sideband Multi-Channel operation of Short-Wave Point-to-Point Radio Links. - Part 2.	154
P	
Page, E. A. The Public Utilities Street Works Act, 1950 ..	8
Polarised Relays, A Simple Tester for Adjustment of ..	134
Postal Order Printing and Issuing Machine, A	11
Public Utilities Street Works Act, 1950, The	8
R	
Radio Conference, Geneva, 1951, The Extraordinary ..	85
Radio Links, Single-Sideband Multi-Channel Operation of Short-Wave Point-to-Point	97, 154
Radio Monitoring, An Automatic-Scanning Receiver for ..	149
Reference Circuit using Adjustable Interruption Distortion, A Telephone Transmission	175
Reflectionless Joints for Coaxial Pairs	72
Regional Notes	40, 90, 137, 181
Research Station Dollis Hill, A Visit by His Royal Highness the Duke of Edinburgh to the	143
Richards, D. L., and J. N. Shearme. A Telephone Transmission Reference Circuit using Adjustable Interruption Distortion	175
S	
Seymour, R. A. A New Audio-Frequency Oscillator (Oscillator No. 22)	111
Shearme, J. N., and D. L. Richards. A Telephone Transmission Reference Circuit using Adjustable Interruption Distortion	175
Simple Tester for Adjustment of Polarised Relays, A ..	134
Single-Sideband Multi-Channel Operation of Short-Wave Point-to-Point Radio Links:	
Part 1.—General Survey	97
Part 2.—An Independent-Sideband Transmitter Drive Unit and Monitor Receiver	164
Sound Pressures, An Experimental Probe Microphone for the Measurement of	145

S (continued)	PAGE NO.
Staff Changes	47, 95, 141, 181
Stone, M. C. A Simple Tester for the Adjustment of Polarised Relays	134
Street Works Act, 1950, The Public Utilities	8
Subscribers' Sets, An Instrument for Testing, <i>in Situ</i> ..	121
Swain, E. C., and H. Fielding. Telecommunication Problems arising from Hydro-Electric Schemes in Scotland ..	10

T	
Telecommunication Problems arising from Hydro-Electric Schemes in Scotland	10
Telephone Transmission Reference Circuit using Adjustable Interruption Distortion, A	175
Television Receivers, The Detection of	41
Test Equipment for the London Centre of the C.C.I.F. Field Trials of International Semi-Automatic Telephone Operation	163
Thermal Problems of Small Underground Installations ..	1
Timing Unit, A Millisecond	2
Transatlantic Telephone Service—Commemoration of Notable Anniversary	1
Transmission Line, Uniform, An Approach to the Standard Equations for a	30, 81
Transportable Gantry, A 30-cwt	17
Turner, R. J. Reflectionless Joints for Coaxial Pairs ..	7

U	
Underground Installations, Thermal Problems of Small ..	1
Urban, T. F. A. The Fault Recorder or Docket Printing Machine	11
Use of Explosives in External Operations, The	5

V	
Visit by His Royal Highness the Duke of Edinburgh to the Post Office Research Station Dollis Hill, A	14

W	
Wray, D. A Combining Unit for Superimposing Two Television Pictures on the Same Cathode Ray Tube ..	17

BOARD OF EDITORS

H. FAULKNER, C.M.G., B.Sc., M.I.E.E., F.I.R.E., Chairman.
W. WEST, B.A., M.I.E.E.
L. F. SCANTLEBURY, Whit.Sch., A.C.G.J., D.I.C., A.M.I.E.E.
D. A. BARRON, M.Sc., A.M.I.E.E.
H. STANESBY, M.I.E.E.
E. DAVIS, A.M.I.E.E.
L. CHANT.
G. E. STYERS, A.M.I.E.E., Managing Editor.
W. A. HUMPHRIES, A.M.I.E.E.
J. P. HARDING, B.Sc.(ENG.).
A.M.Inst.C.E., A.M.I.E.E. } Assistant Editors.
A. J. HUTCHISON, Secretary-Treasurer.

Copyright

The entire contents of this JOURNAL are covered by general copyright, and special permission is necessary for reprinting long extracts, but Editors are welcome to use not more than one-third of any article, provided credit is given at the beginning or end thus: "From the *Post Office Electrical Engineers' Journal*."

The Board of Editors is not responsible for the statements made or the opinions expressed in any of the articles in this JOURNAL, unless such statement is made specifically by the Board.

Communications

All communications should be addressed to the Managing Editor, *P.O.E.E. Journal*, Engineer-in-Chief's Office, Alder House, Aldersgate Street, London, E.C.1. Telephone: HEADquarters 1234. Remittances should be made payable to "*The P.O.E.E. Journal*" and should be crossed "& Co."

Binding Cases

Cases for binding are available, and may be obtained from the Local Agents for 3s. Subscribers can have their copies of volume bound, at a cost of 10s. 6d., by sending the complete set of parts to the Local Agents or to the *P.O.E.E. Journal*, Engineer-in-Chief's Office, Alder House, Aldersgate Street, London, E.C.1. Orders for binding for Vols. 1-19 should indicate whether the original binding case with black lettering, or the later pattern with gold, is required. Cases with gold lettering are the only type stocked from Vol. 2 onwards.

Back Numbers

The price of the JOURNAL, which is published quarterly, is 2s. 6d. (2s. 9d. post free) per copy, or 11s. per annum, post free. Back numbers can be supplied, subject to availability of stocks, at 2s. 6d. each (2s. 9d. post free). Orders for back numbers may be sent to the *P.O.E.E. Journal*, Engineer-in-Chief's Office, Alder House, Aldersgate Street, London, E.C.1, or to the Publishers.

Employees of the British Post Office can obtain the *Journal* through Local Agents at the reduced price of 2s. per copy.

Advertisements

All communications relating to space reservations should be addressed to the Advertisement Editor, *P.O.E.E. Journal*, Alder House, Aldersgate Street, London, E.C.1. Communications regarding advertisement copy, proofs, etc., should be addressed to the Publishers, Messrs. Birch & Whittington (Prop. Dorling & Co. [Epsom], Ltd.), 49 Upper High Street, Epsom, Surrey.

INDEX TO ADVERTISERS

	PAGE
Airmec Laboratories, Ltd.	xxvii
Alton Battery Co., Ltd., The	ix
Automatic Coil Winder & Electrical Equipment Co., Ltd.	xxii
Automatic Telephone & Electric Co., Ltd.	xii-xiii, xvi-xvii
Bennett College, The	ii
British Power Transformer Co., Ltd.	xxvi
Creed & Co., Ltd.	xix
Dubilier Condenser C. [1925], Ltd.	xi
Edison Swan Electric Co., Ltd., The	xxviii
E.M.I. Institute	ii
Ericsson Telephones, Ltd.	iv
General Electric Co., Ltd., The	xiv-xv
Great Northern Telegraph Co., Ltd.	xxiii
Hackbridge Cable Co., Ltd.	xxiii
Hivac, Ltd.	iii
International Correspondence Schools, Ltd.	xxvii
Jones, Walter, & Co. (Engineers), Ltd.	xxvi
Marconi Instruments	viii
Marconi's Wireless Telegraph Co., Ltd.	x
Muirhead & Co., Ltd.	vii
Mullard, Ltd.	v, vii
Painton of Northampton	vi
Pirelli-General Cable Works, Ltd.	xxviii
Pitman, Sir Isaac, & Sons, Ltd.	iii
Savage Transformers	ii
Siemens Brothers & Co., Ltd.	xviii
Smith, Frederick, & Co.	ii
Standard Telephones & Cables, Ltd.	xx-xxi
Sullivan, H. W., Ltd.	xxiv
Telephone Manufacturing Co., Ltd.	xxii
Tungstone Products, Ltd.	xxv
Westinghouse Brake & Signal Co., Ltd.	xxiv
Winn & Coales, Ltd.	xxvii

PITMAN

Telephony (2 vols.)

By J. Atkinson, A.M.I.E.E., Area Engineer, Post Office Engineering Department. A standard textbook for Post Office engineers and students. With over 1,500 illustrations. Vol. I (General Principles and Manual Exchange Systems), 35/- net. Vol. II (Automatic Exchange Systems), 55/- net.

Telecommunications Principles

By R. N. Renton, M.A.I.E.E. A useful work covering the syllabus for the City and Guilds examinations in Telecommunications Principles, Grades I, II and III. Illustrated, 37/6 net.
"Can be recommended confidently to all students of Telecommunications."—POST OFFICE TELECOMMUNICATIONS JOURNAL.

Alternating Current in Telecommunications

By W. T. Palmer, B.Sc.(Eng.), Wh.Ex., M.I.E.E., A.M.I. Mech.E. A useful little introduction to the basic principles of alternating current theory, for engineers commencing their studies for a career in telecommunications. 4/- net.
"Should be of value to the student who finds the often condensed treatment of the average textbook difficult to follow."—TECHNICAL JOURNAL.

PITMAN, Parker Street, Kingsway, London, W.C.2

SUB-MINIATURISATION

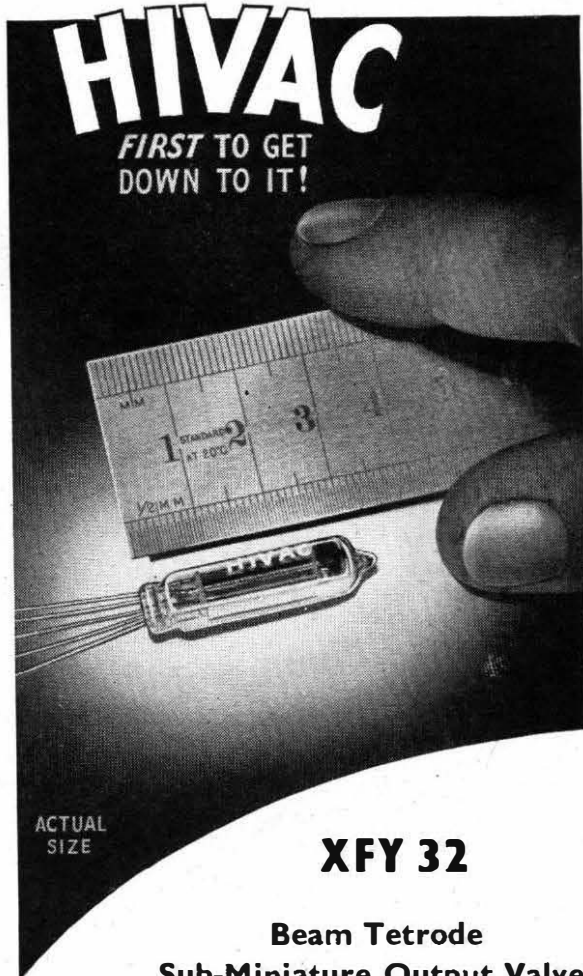

XFY 32

Beam Tetrode
Sub-Miniature Output Valve

TYPICAL OPERATION

Filament Voltage	1.25	1.25	1.25 V.
Filament Current	12.5	12.5	12.5 mA.
H.T. Voltage	16.25	22.5	30 V.
Control Grid Voltage	0	-1.5	-2.75 V.
Power Output	1.1	2.7	6.0 mW.

The maximum cross-section is only 8 mm. x 6 mm. with a maximum glass length of 35 mm. and the nominal filament current is 12½ mA.

These features, in conjunction with the high efficiency of the XFY32 permit still greater saving in space whilst maintaining exceptionally fine performance.

HIVAC

THE SCIENTIFIC
VALVE

Hivac Ltd.

Telephone: HARROW 2655
GREENHILL CRESCENT, HARROW-ON-THE-HILL, MIDDLESEX

The 'DEKATRON'

A MULTI-ELECTRODE
COLD-CATHODE
COUNTING TUBE

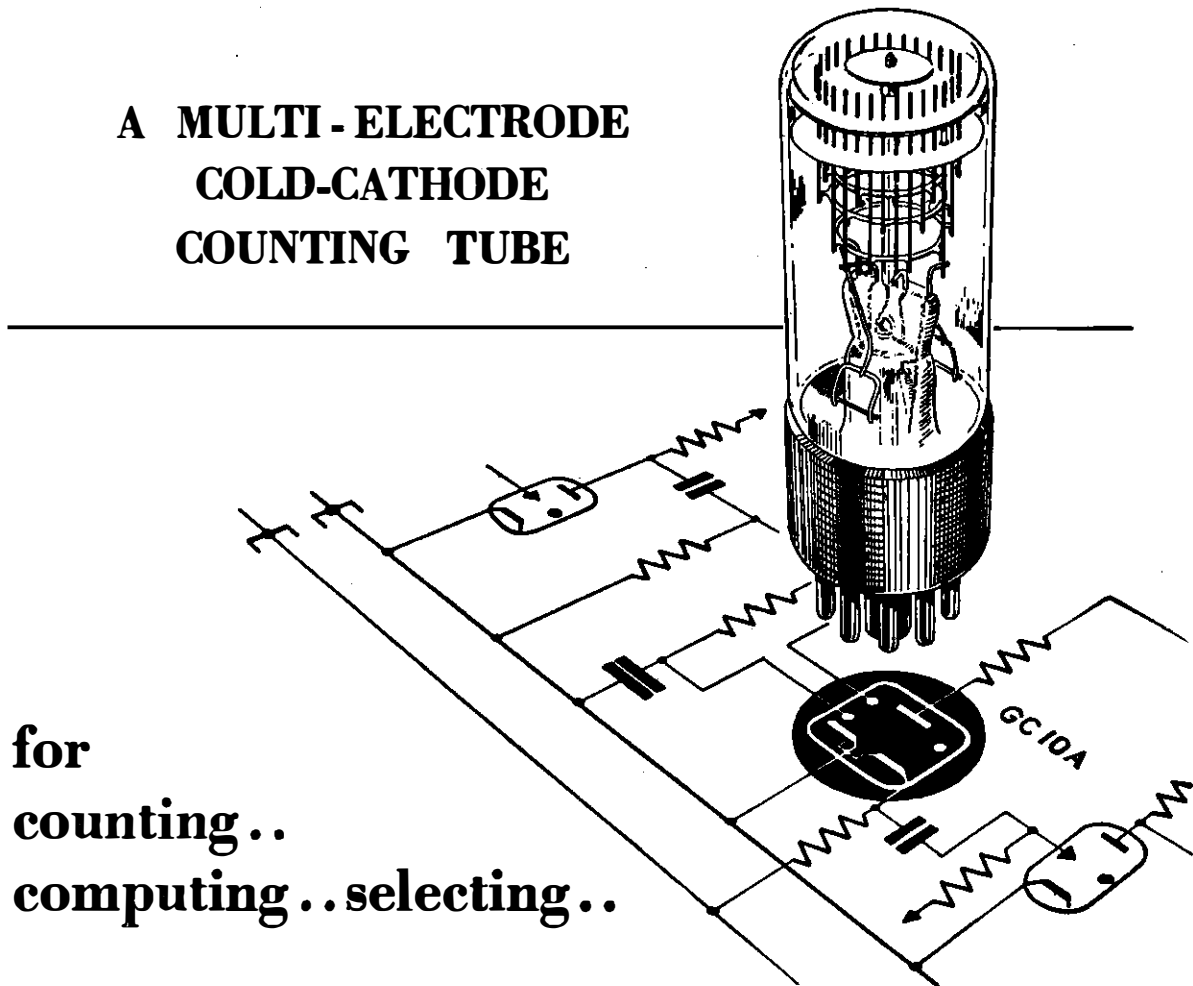

Ericsson

TELEPHONES LTD.

22 LINCOLN'S INN FIELDS, LONDON, W.C.2 · Tel. HOLborn 6936 · Works: BEESTON, NOTTS.

26



*Mullard Ferroxcube
being extruded into
rods for H.F. cores.*

MAGNETIC MATERIALS Extensive

research and manufacturing facilities have established Mullard as the leading producers of magnetic materials.

They were the first, for example, to introduce Ferroxcube, the world's most efficient magnetic ferrite; 'Ticonal' anisotropic permanent magnets, renowned for their high stability and high energy output; and Ferroxdure, an entirely new type of permanent magnet with the insulating properties of a ceramic.

The wealth of experience gained from these developments is available to all users of magnetic materials through the Mullard advisory service. An enquiry to the address below will put a team of specialised engineers at your disposal.



Mullard

**'TICONAL' PERMANENT MAGNETS • FERROXDURE PERMANENT MAGNETS
FERROXCUBE MAGNETIC CORE MATERIAL**

MULLARD LTD., COMPONENT DIVISION, CENTURY HOUSE, SHAFTESBURY AVENUE, LONDON, W.C.2.



By Appointment to the Professional Engineer...

ATTENUATORS · FADERS · STUD SWITCHES AND TOGGLE SWITCHES
WIREWOUND POTENTIOMETERS · HIGH STABILITY CARBON RESISTORS
WIREWOUND RESISTORS · PLUGS AND SOCKETS · TERMINALS
KNOBS DIALS AND POINTERS

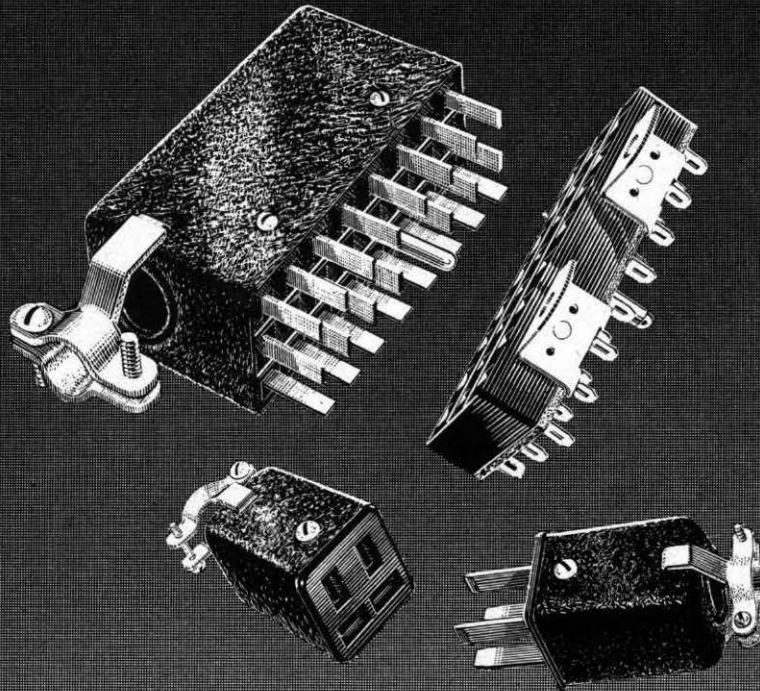

MULTI-CONTACT PLUGS AND SOCKETS

Rating: 5 Amps./500 volts. Silver-plated Beryllium-Copper contacts
From 2 way—33 way types available, with alternative mountings and cover facilities.

PAINTON
Northampton England



**THIS INTERESTING QUARTERLY
WILL BE MAILED *FREE*
TO ANY PART OF THE WORLD
POST THIS COUPON TODAY**

MUIRHEAD & CO. LTD · BECKENHAM · KENT · ENGLAND

Please mail me, free of charge, your quarterly journal "technique"

NAME _____

POSITION _____

COMPANY _____

ADDRESS _____

76

MUIRHEAD & CO. LTD · BECKENHAM · KENT · ENGLAND
PRECISION ELECTRICAL INSTRUMENT MAKERS



A compact through-supergroup filter

DESIGNED FOR QUANTITY PRODUCTION

THE Mullard Through-Supergroup Filter, GTF.100, is designed for manufacture by normal quantity production methods. Conventional condensers and coils with Ferroxcube cores are used throughout. As a result, it is available at a comparatively low price. The necessary amplifiers have been incorporated in the design, so that the Filter is complete on a single 19-inch panel which is only 12½ inches high.

In both design and performance the GTF.100 fully meets the rigorous specifications necessary for filters that must separate supergroups in the frequency allocation standardised by the C.C.I.F.

Complete details of the Mullard Through-Supergroup Filter are available on request.

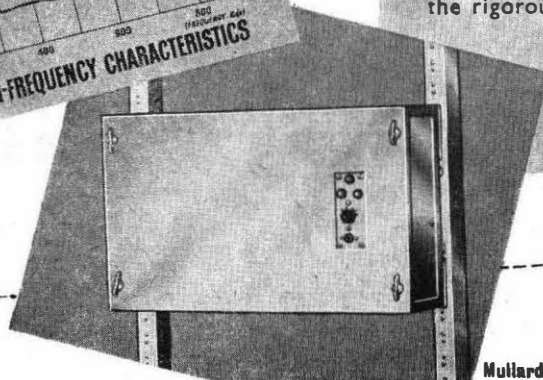

Mullard

Mullard Ltd., Equipment Div., Century House, Shaftesbury Avenue, W.C.2
(M403A)

Exceptional impedance range

With forty-eight impedance steps from 2.5Ω to $20,000\Omega$ for balanced inputs—and a similar number for unbalanced at one-quarter the impedance—the instrument is ideal for optimum load matching. Two important design features play a great part in this meter's excellent performance over so wide a range of impedance. First, the use of a resistance network* to select the significant figures of the input impedance value. Second, decade multiplication of impedance by a transformer with a wound-strip core of anisotropic alloy.

* Brit. Pat. 648,944



AUDIO FREQUENCY OUTPUT POWER METER TF893

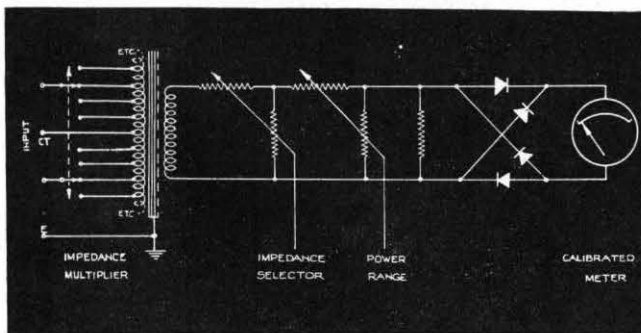

RANGE

Power:

20 μ W to 10W in five ranges

Impedance:

0.625 Ω to 20,000 Ω

Frequency:

Practically flat response over range exceeding 500:1

MARCONI INSTRUMENTS

SIGNAL GENERATORS • VALVE VOLTMETERS • FREQUENCY STANDARDS • BRIDGES • WAVE METERS • WAVE ANALYSERS • BEAT FREQUENCY OSCILLATORS

MARCONI INSTRUMENTS LIMITED • ST. ALBANS • HERTS • TELEPHONE: ST. ALBANS 6161/7

Midland Office: 19 The Parade, Leamington Spa. **Northern Office:** 30 Albion Street, Hull. **Export Office:** Marconi House, Strand, London, W.C.2

From Alton go batteries to power stations all over the world. Batteries, as their distant users tell us, that possess a certain distinctive merit all their own. Surprising, in these days of uniformity and standardisation? But Alton, in such an age, is perhaps a surprising place. Alton's a small country town, with a friendly, satisfying life of its own. A natural place unchanged, unspoiled, where the surrounding streams run down through lovely and varied country to feed the river Itchen pictured below. Where a man at leisure can follow his bent, be it sport or hobby or just plain peace of mind. Where a life worth living, a job worth doing are any man's natural right : and pride in himself and the work of his hands is a wholly natural consequence.

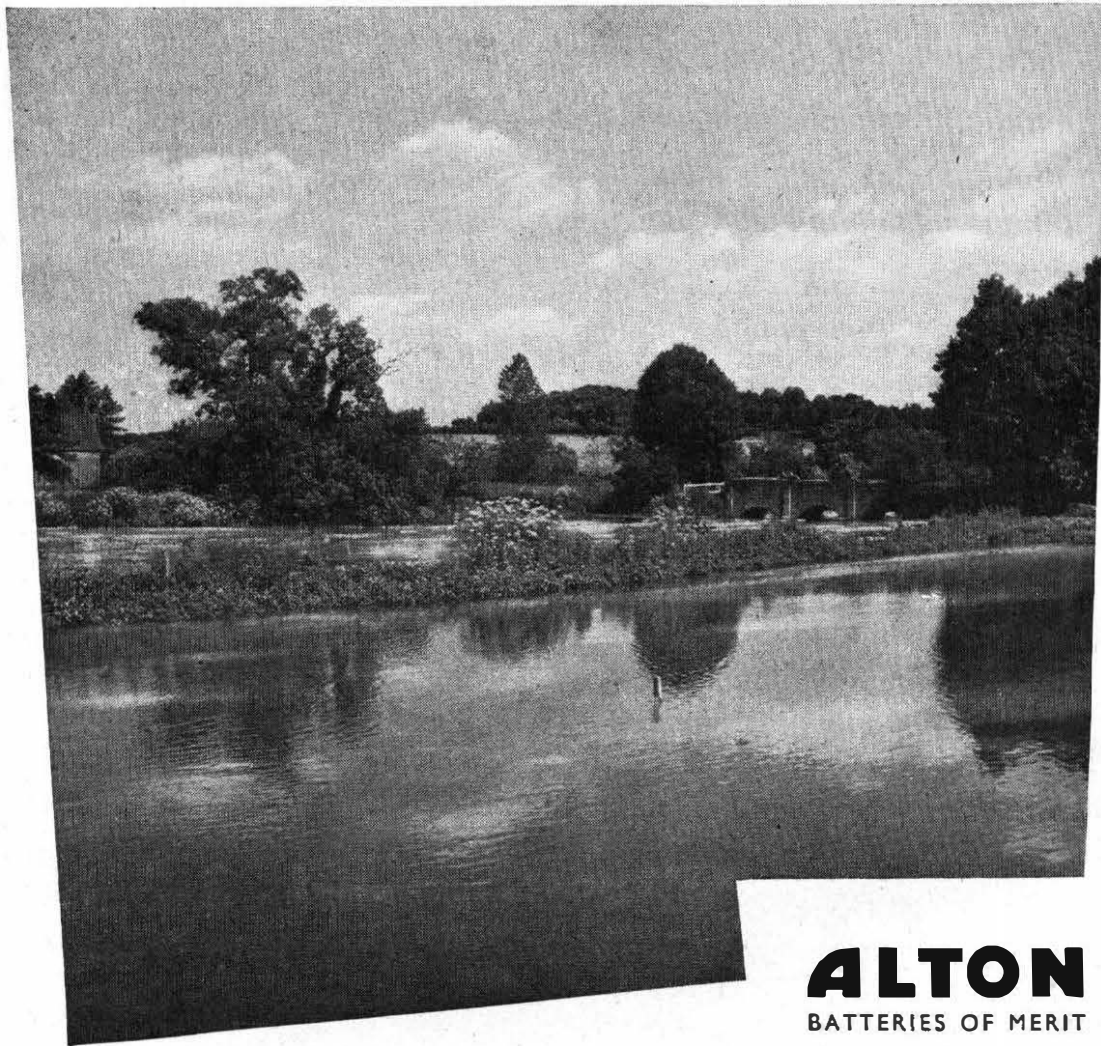

ALTON
BATTERIES OF MERIT

Alton stationary batteries: 10 to 15,000 Ah. Also in regular production, renewal plates for all makes of battery, British and Continental

A23A

The Alton Battery Company Limited · Alton · Hants · Telephone: Alton 2267 and 2268 · Telegrams: Battery, Alton

MARCONI communication systems

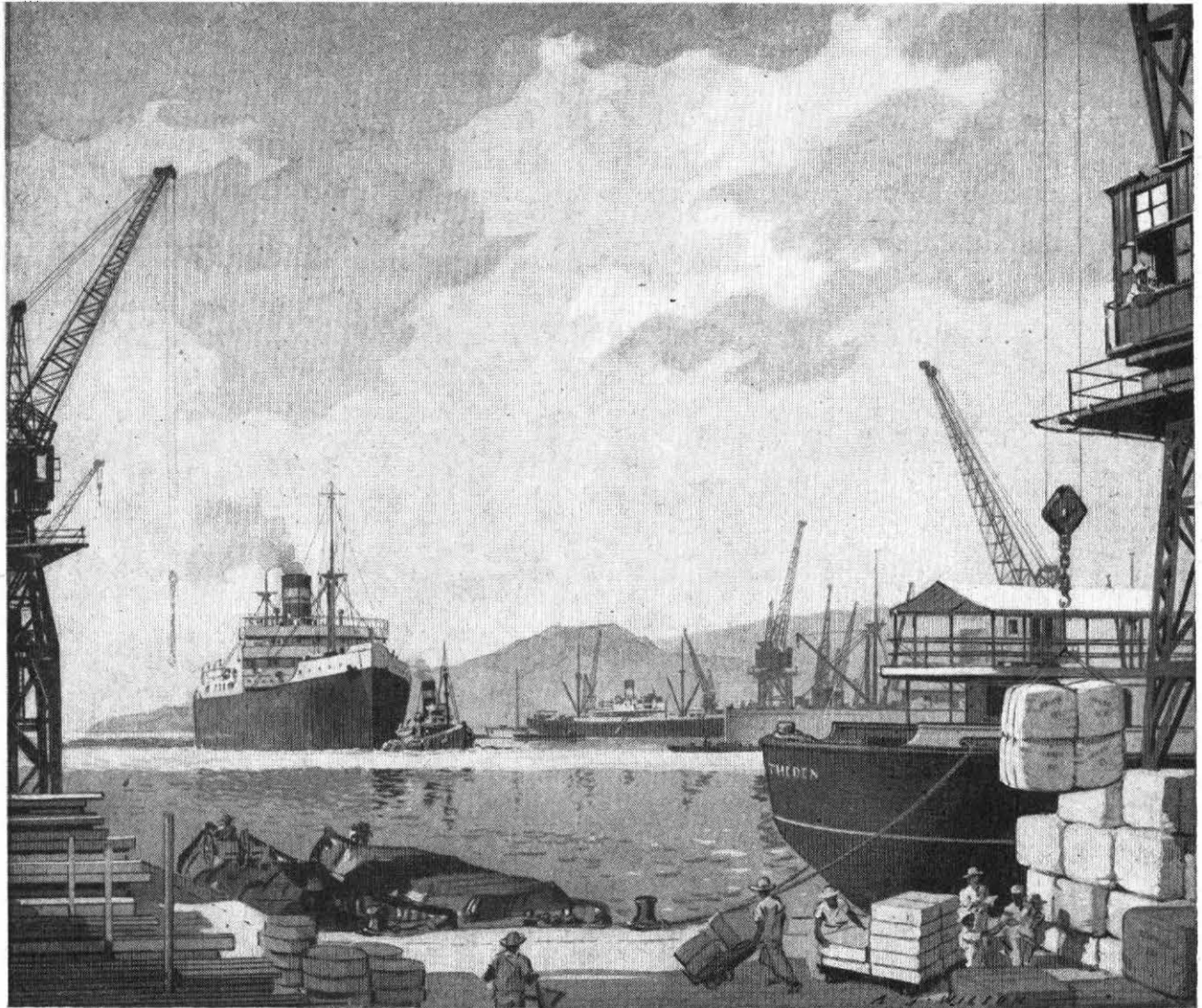

serve mankind

Before Guglielmo Marconi's invention of wireless, a ship out of sight of land was literally cut off from the world. Today you can, in a matter of minutes, contact a ship

in mid-Atlantic. Such is the measure of his service to communications and safety at sea. Such too, is the measure of his ideals, which still inspire the Company he founded.



SURVEYED



PLANNED

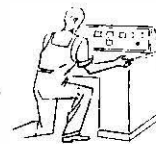

INSTALLED

MARCONI'S WIRELESS TELEGRAPH COMPANY LTD · CHELMSFORD · ESSEX

DUBILIER

MICA DIELECTRIC CAPACITORS

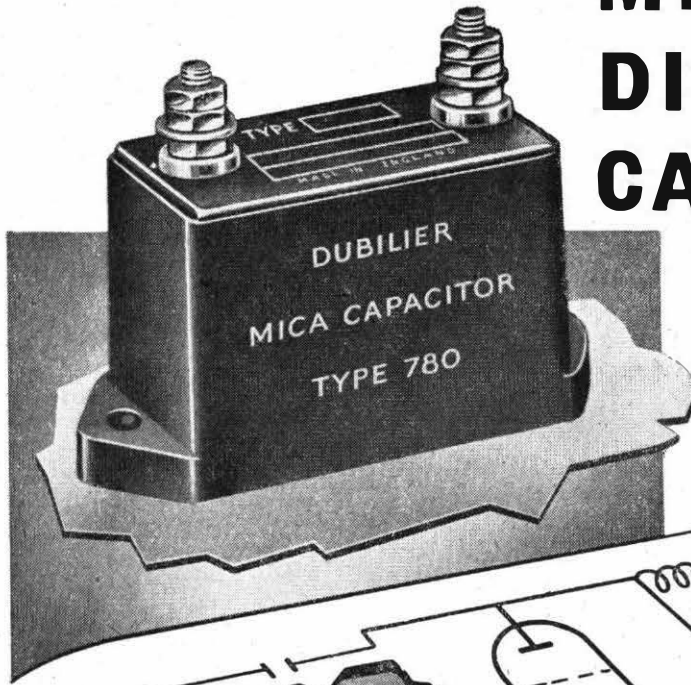

*Eminently Suitable for
H.F. Transmitting and
R.F. Heating Circuits*

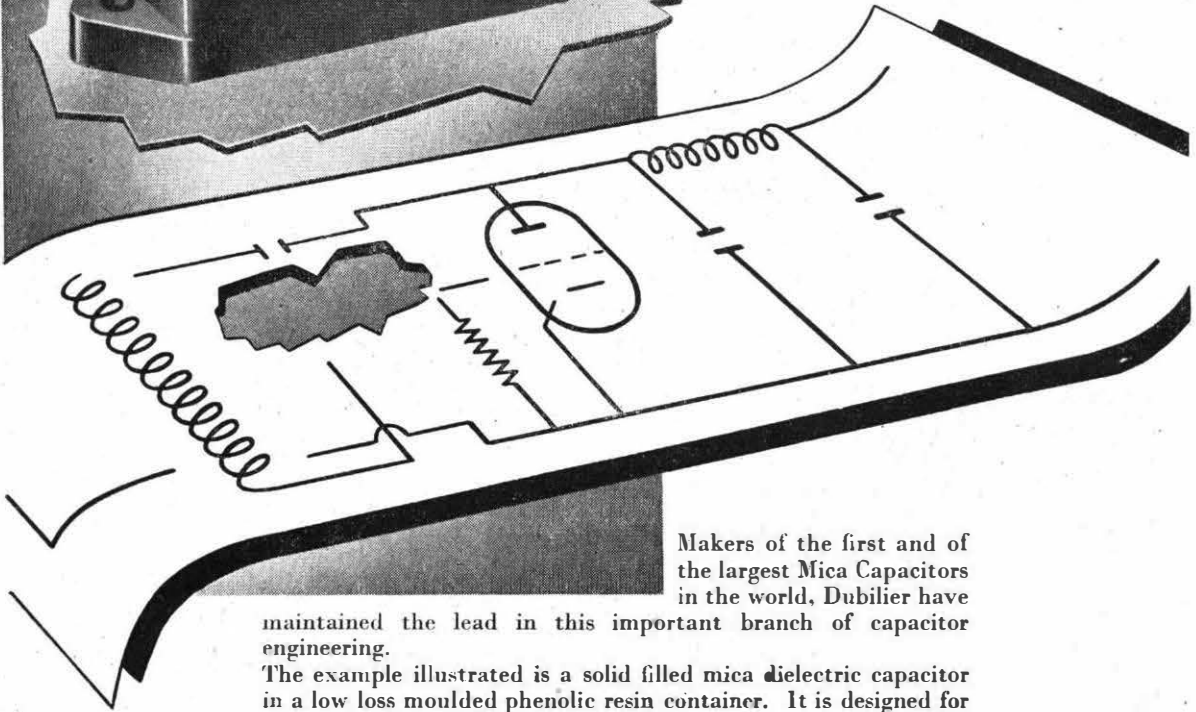

Makers of the first and of the largest Mica Capacitors in the world, Dubilier have

maintained the lead in this important branch of capacitor engineering.

The example illustrated is a solid filled mica dielectric capacitor in a low loss moulded phenolic resin container. It is designed for use on medium D.C. voltages, with a small superimposed R-F current, or as the tank circuit capacitor in low power medium and long wave transmitting equipment.

Full details of capacitance values and ratings are available on request.

DUBILIER CAPACITORS

DUBILIER CONDENSER CO. (1925) LTD., DUCON WORKS, VICTORIA RD., NORTH ACTON, W.3.
Phone: Acorn 2241 (5 lines). Cables: Hivoltcon, London. Marconi International Code. Grams: Hivoltcon, Wesphone, London.

D73



ANOTHER STROWGER EXCHANGE

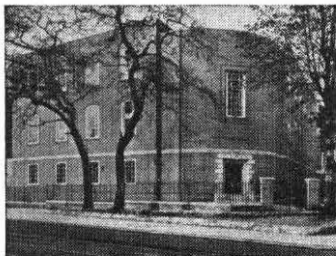

LEE GREEN AUTOMATIC EXCHANGE is one of the latest to be commissioned by the British Post Office for the London Director network. Direct dialling facilities are provided for a maximum of 10,000 subscribers to 185 exchanges and the majority of the 1,500,000 telephones in the area.

Whilst uniselectors are used for the subscriber's line equipment the type 32A (B.P.O. type 2000) two-motion selector is the selecting mechanism and incorporates in its design all the facilities which many years' operational experience has shown to be necessary; the simple straight-forward step-by-step principle of operation characteristic of the Strowger system has been retained. Termed Type 32A Mark II this selector to-day embodies all the qualities of progressive development and offers the most suitable basis for automatic telephone systems of any size. Its simplicity, economy, reliability, and ease of maintenance are the factors of principal appeal to telephone administrations in all parts of the world.



Automatic Telephone & Electric Co. Ltd.

Export Department: Strowger House, Arundel Street, London, W.C.2.

Telephone: TEMple Bar 9262. Cablegrams: Strowgerex, London. Strowger Works, Liverpool, England

AT.7741-AA104

How automatic is a telephone exchange ?

In operation it is fully automatic, but there is nothing automatic about its maintenance. Only man-hours expended by skilled personnel will guarantee efficient maintenance. Since the virtues and failings of a telephone system must depend ultimately on the ease or difficulty of maintenance, the G.E.C., after years of research, has re-designed apparatus used in the Strowger system, to obtain greater reliability, maximum ease of adjustment and instant accessibility. The results are now apparent in the new G.E.C. two-motion selectors, the heavy- and light-duty uniselectors and the trigger dial. All of them can now be maintained with much less skill and in much less time than ever before. Combined with the electrical simplicity exclusive to the Strowger system, these components mean that automatic exchanges manufactured by the G.E.C. are the most valuable investment an Administration can make.

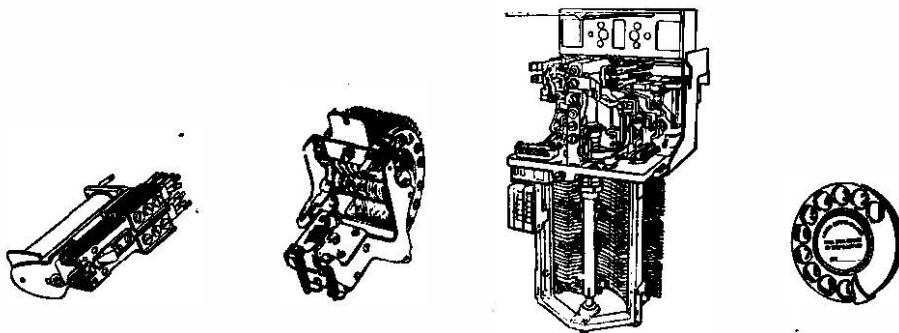

CUTTING COSTS OF MAINTENANCE

CLOSE FITTING and grooved number ring excludes dust from the front.

Transparent rear cover available for dusty locations.

FRONTAL APPEARANCE enhanced by highly polished stainless steel finger-plate of light and durable construction.

IMPULSE RATIO

closely controlled by a precision-made impulse wheel actuating an articulated trigger.

- (a) *Ensuring positive action.*
- (b) *Giving maximum pre-impulsing delay.*
- (c) *Eliminating clipped or spurious impulses.*

Adverse effect on ratio due to any wear on impulsing parts is offset by wear on contacts.

Known contact gap simplifies ratio setting on site.

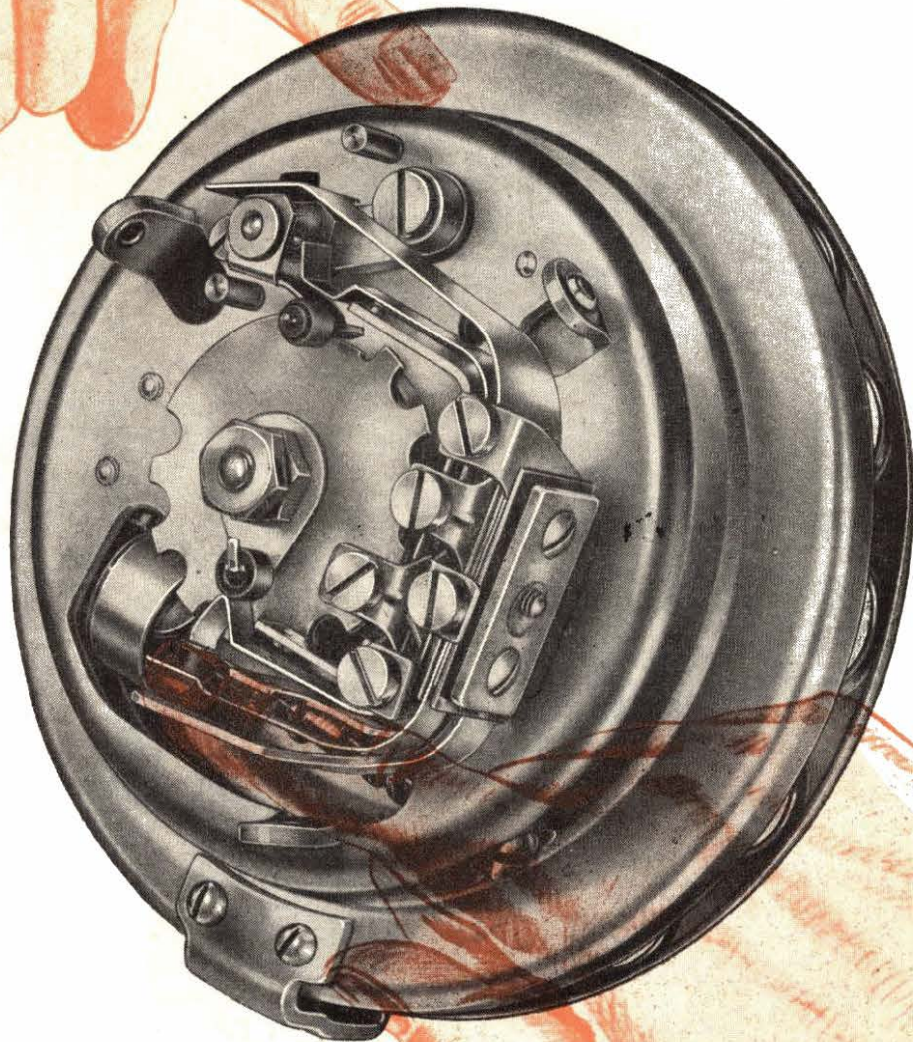

SPEED MAINTAINED through:

Accurately hobbled gear train employing worm wheel of fine fabric laminated plastic.

Finely finished governor worm, weights and cup.

Full particulars are given
in Leaflet DSL 1

G.E.C.

OF ENGLAND

THE GENERAL ELECTRIC CO. LTD. OF ENGLAND
Telephone, Radio & Television Works, Coventry

Telephone link

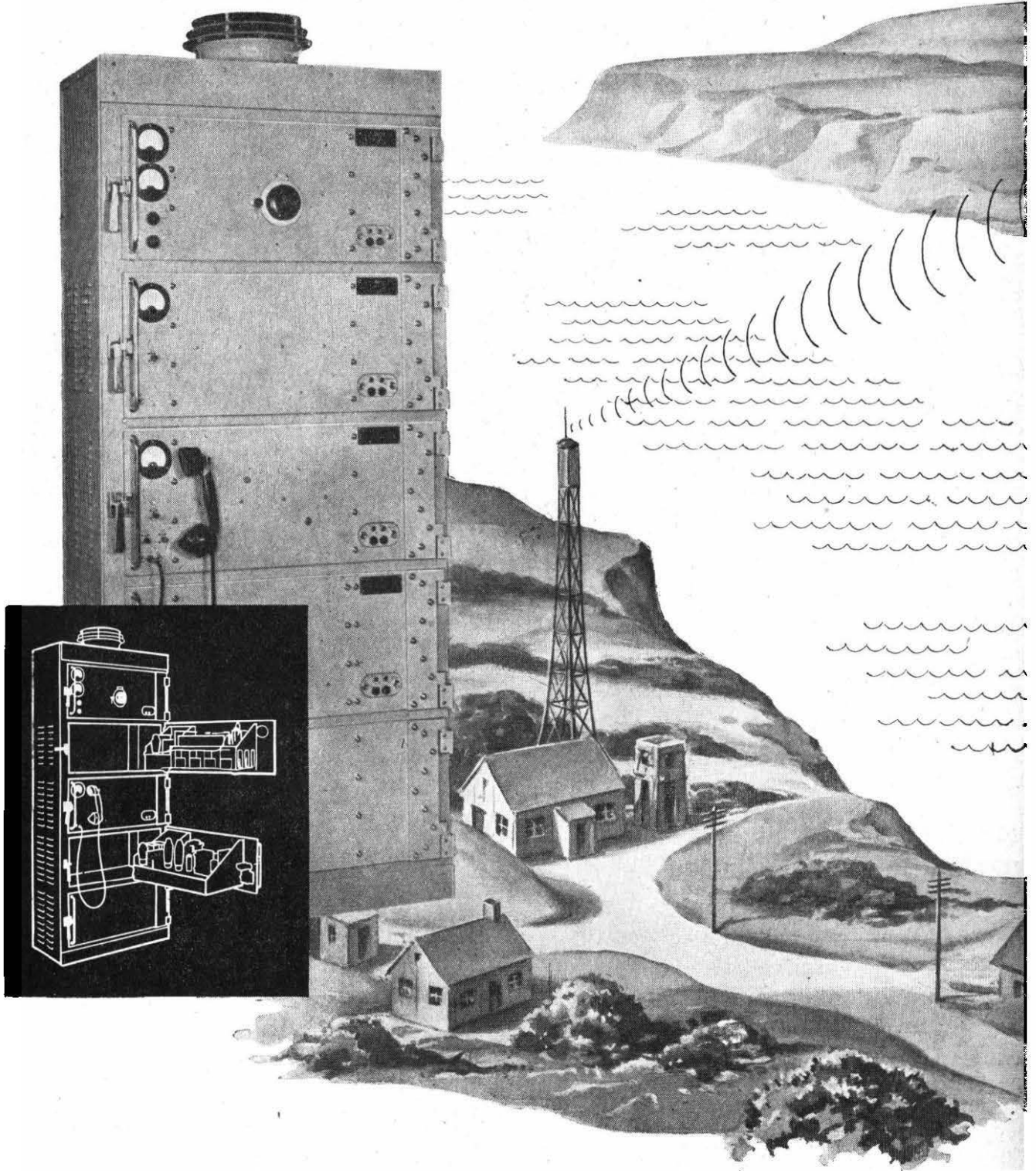

by Radio

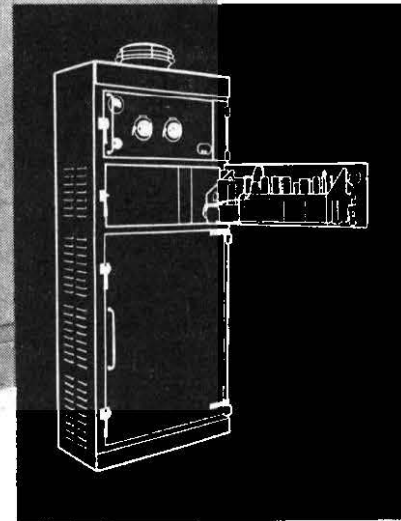
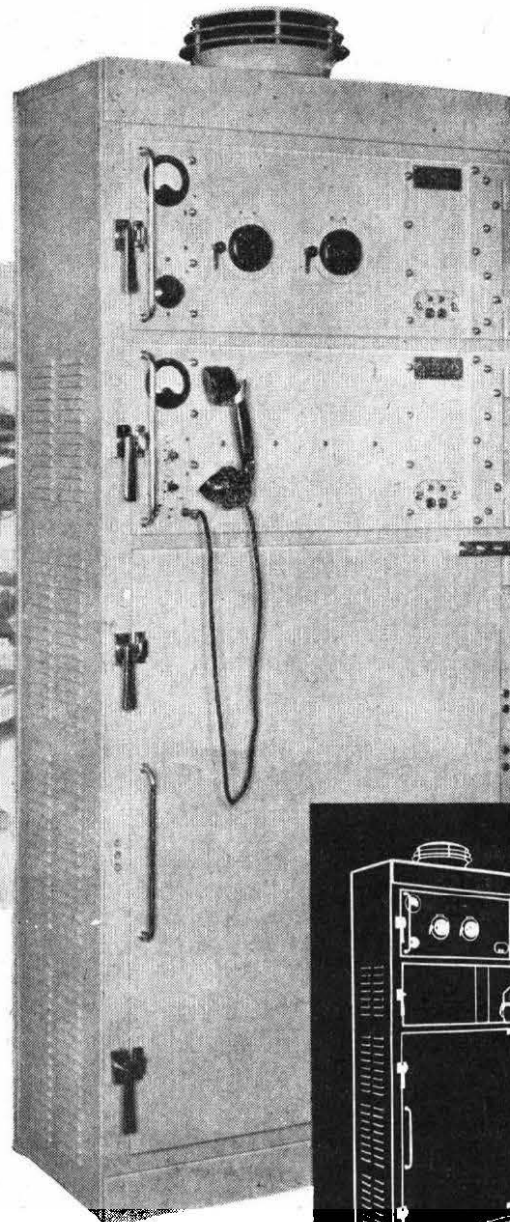
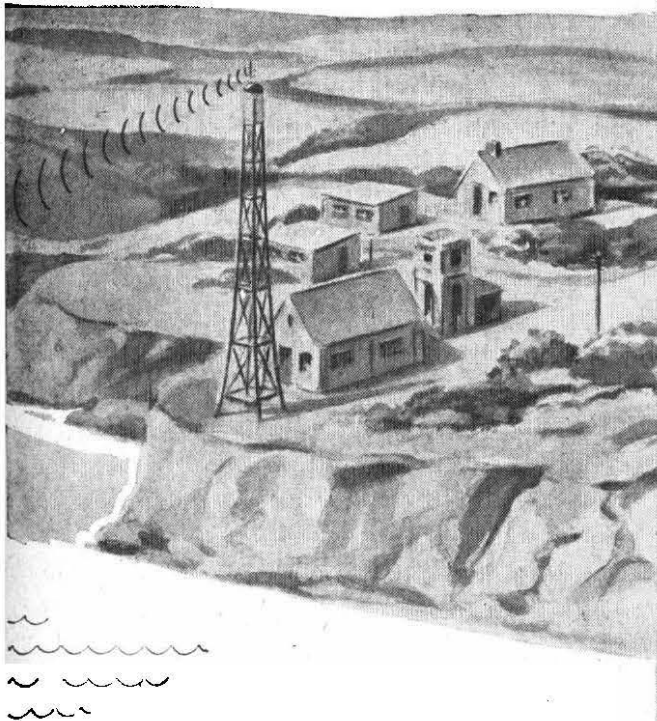

The type VMS Broadband V.H.F. radio equipment has been designed to overcome the tele-communications problem existing in areas where the provision of landlines for trunk communications is impracticable or uneconomical.

Operating in the V.H.F. band, the system caters for the transmission of up to 36 telephone channels to C.C.I.F. standards. When used in conjunction with VMR repeater equipment links up to several hundred miles in length can be established.

VMS/VMR equipment has been planned on the basis of maximum accessibility to simplify maintenance; the sub-unit construction employed facilitates fault localisation, and permits the rapid replacement of defective units by semi-skilled staff.

A.T.M. engineers are always prepared to study your problems, and to recommend the most suitable equipment for your complete system from the comprehensive range of A.T.M. products, which includes channelling equipment of all types and other essential V.H.F. radio items, such as aerials, filters, automatic changeover gear, towers and feeder cables. In addition, specially equipped teams are available to conduct field surveys in any part of the world to ascertain the most suitable equipment and station sites for any project.



AUTOMATIC TELEPHONE & ELECTRIC CO. LTD.,

R & T. DIVISION, STROWGER HOUSE, ARUNDEL STREET, LONDON, W.C.2
Telephone: TEMple Bar 9262. Cablegrams: Strowgerex, London.

SIEMENS

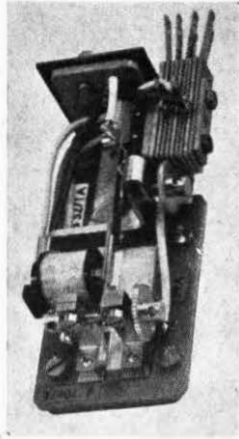

Automatic Switching Apparatus

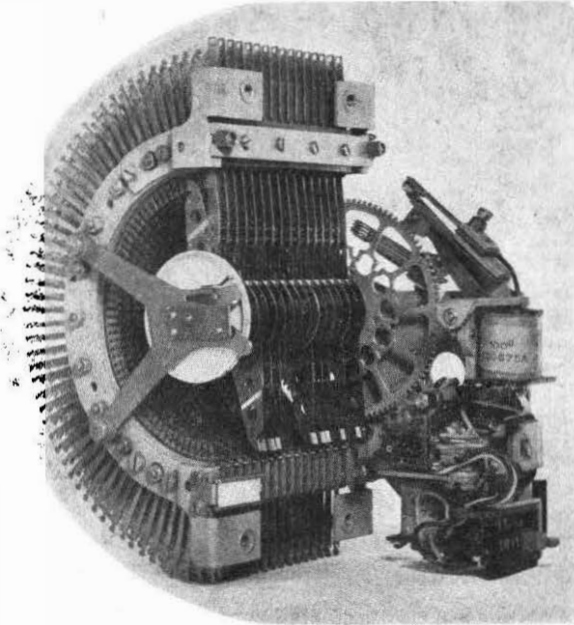

TYPE 89 HIGH-SPEED
RELAY with
single changeover.

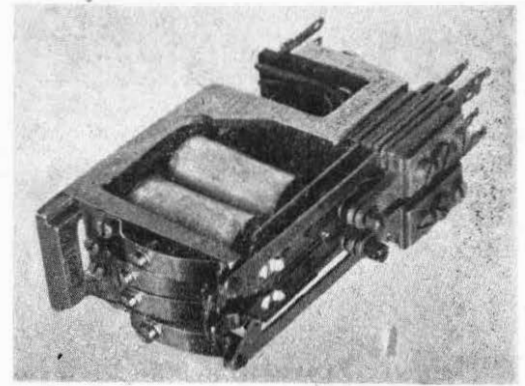

TYPE 100 HIGH-SPEED RELAY
with double changeover action.

MOTOR UNISELECTOR
operates at 200 steps
per second.

The apparatus shown has earned a reputation for high efficiency, long life and low fault liability, and is employed in the Company's

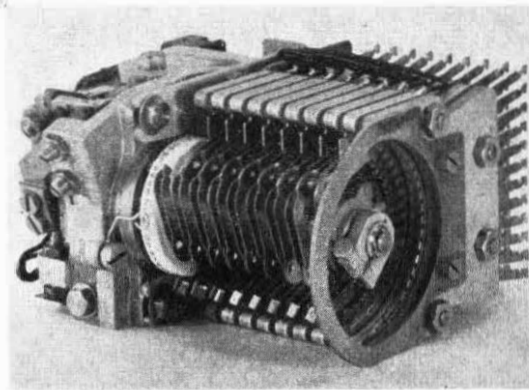

THE DIGIT SWITCH
for marking outlets
and for use as a
distributor.

No. 17 M.A.X. System

and

Motor Uniselector Auto Trunk Schemes

SIEMENS BROTHERS & CO., LIMITED
WOOLWICH • LONDON • S. E. 18.

Facsimile

ELECTRONIC MESSAGE COMMUNICATION



Desk-Fax

THE Desk-Fax is a simple electronic instrument for transmitting and receiving written messages between remote locations.

Handwriting, typewritten matter and sketches are reproduced with equal facility and the highest fidelity.

It is only necessary to wrap the message around a cylinder and press a button. Transmission takes only two minutes.

The Desk-Fax does not make errors.

It's small, it's fast, it's silent in operation and it's dependable.

Creed & Company Limited

TELEGRAPH ENGINEERS

CROYDON · ENGLAND

Communication

Standard Systems in Service

Indicative of the activities of STANDARD TELEPHONES AND CABLES LIMITED in the field of telecommunication engineering is the major contribution made by the Company to the establishment and extension of Britain's Television network.

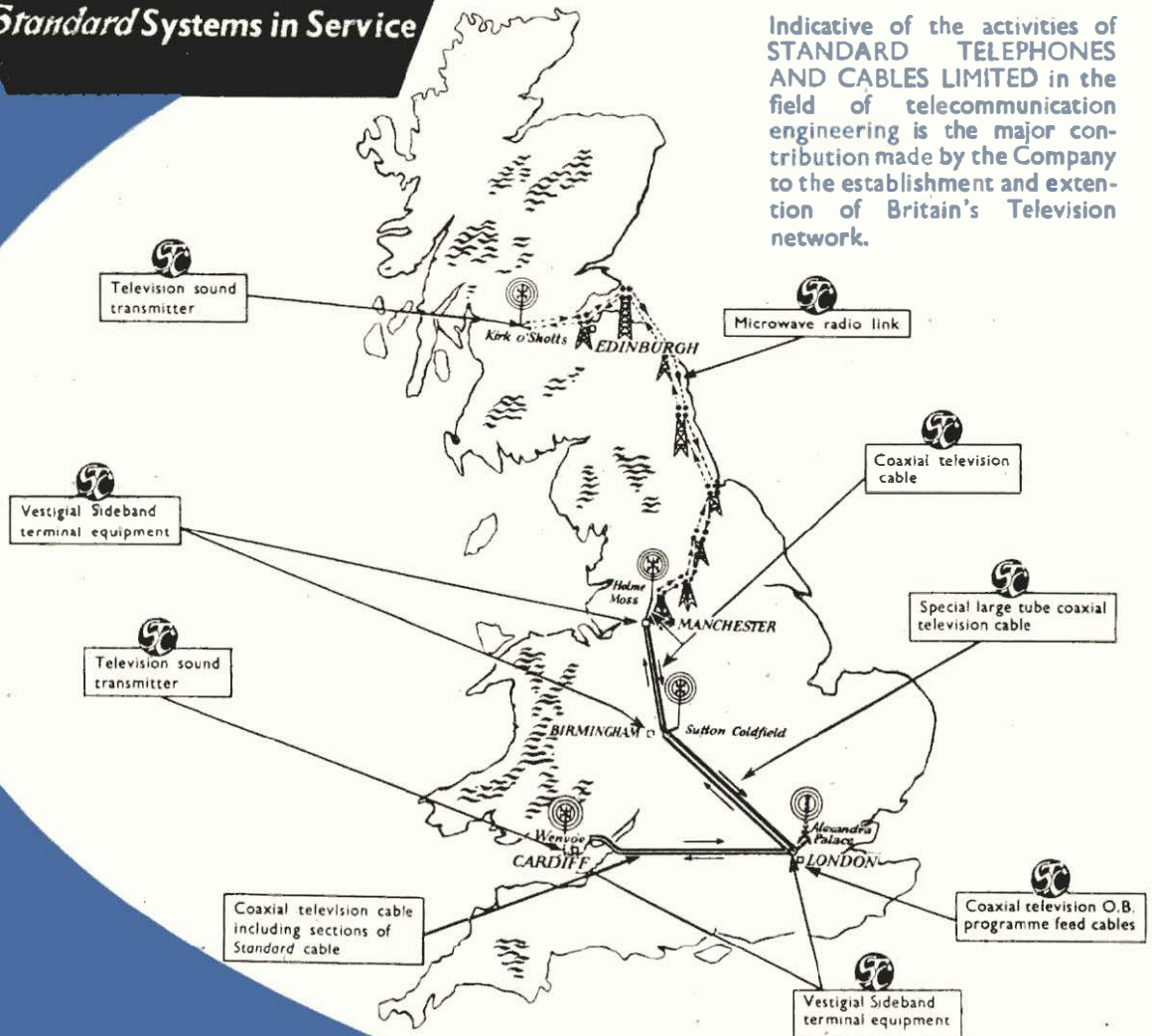

The G.P.O. television network showing links supplied by Standard Telephones and Cables Limited



Standard Telephones

(TELECOMMUNICATION)

Connaught House, Aldwych,

Cairo

Dublin

Johannesburg

and Control

Standard systems include:—

Standard's wide resources, their long experience in the design and manufacture of systems and equipment for telecommunications and control have enabled them to produce an extensive range of apparatus for use in all parts of the world.

These resources and experience are at your service, either for the systems listed or for their development to meet specific needs, as well as for the supply of equipment, materials and components including:—

Power Factor Correction

Capacitors

Magnetic alloys

SenTerCel Selenium Rectifiers

Thermionic Valves

Quartz crystals

Telephone
Telegraph
Teleprinter
Radio Broadcasting
Radio Communication
Radio Navigation
Sound Reproduction
Remote Control
Remote Indication
Telemetry
Railway Signalling
Railway Control
Power Cable
Communication Cable
Airfield Lighting Control
Street Lighting Control
Fire Alarm
Totalisator
Public Indicator
Signalling (Office and Factory)

and Cables Limited

ENGINEERS)

London, W.C.2, England

Karachi

New Delhi

Salisbury

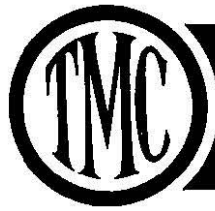
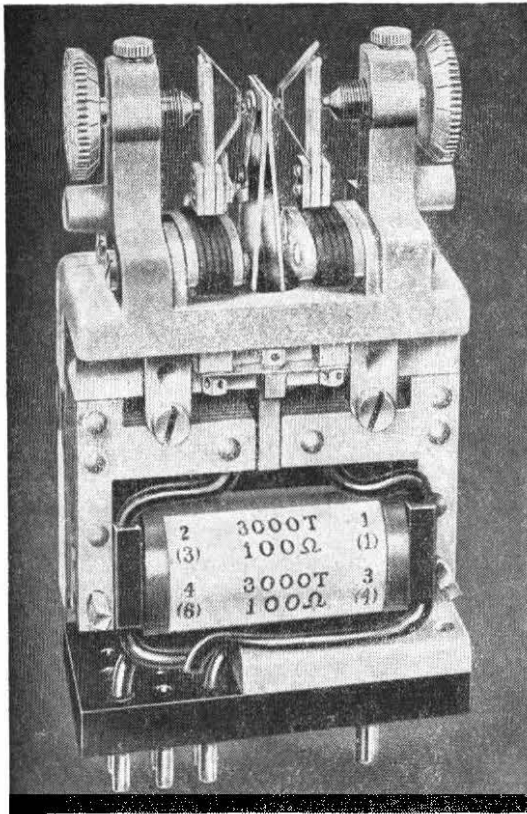

CARPENTER POLARIZED RELAY TYPE 4

The chief characteristics of this relay are low transit time—high contact pressure—freedom from contact chatter and positional error—high sensitivity—stability—symmetrical action—and ease of adjustment.

On V.F. dialling systems its use facilitates the design of sensitive receiving equipment, and on trunk telephone circuits the relay's high sensitivity enables it to respond to D.C. dialled impulses received over unrepeaters trunk lines of up to 100 miles long.

It is particularly suitable as an impulse accepting relay when a minimum of signal distortion is imperative, and because of the excellent change-over action and absence of contact chatter the relay is unequalled for impulsing the selector magnets in teleprinter automatic switching systems.

The relay responds satisfactorily to frequencies up to 100 c/s, when the contact gap is adjusted to 0.004 in. nominal, without serious bias disturbance. It can be left connected to line whilst awaiting a clearing signal, there being little distortion of through signals since the total leak can be of the order of 10,000 ohms.

Dimensionally the relay is interchangeable with the "3000" type relay. Terminations can either be made by means of a 12-pin plug base as illustrated, or with soldering tags in place of the pins. Protection is given by a magnetic screen and a transparent cap which is removable for contact adjustments.

Complete details supplied on request.

Manufactured by the Sole Licensees:—

TELEPHONE MANUFACTURING COMPANY LIMITED

Contractors to Governments of the British Commonwealth and other Nations

HOLLINGSWORTH WORKS · DULWICH · LONDON S.E.21 TEL: GIPSY HILL 2211 (10 LINES)

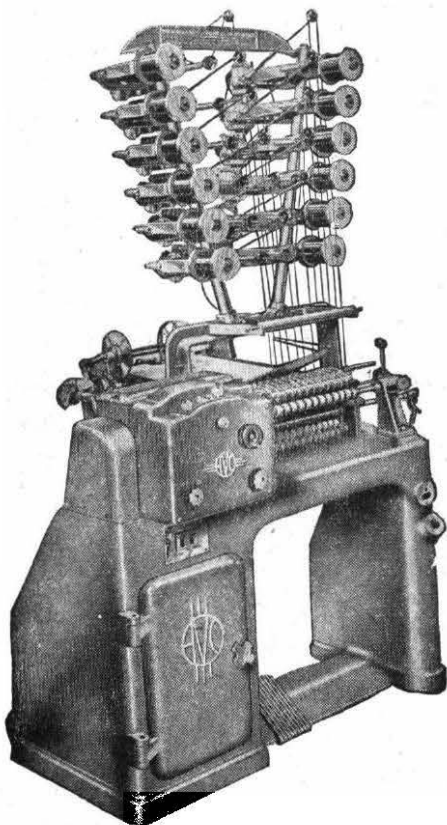

DOUGLAS AND MACADIE

Automatic COIL WINDERS

The large illustration depicts the improved "Douglas" Fully Automatic Multi-Winder, specially developed for the high-speed production of large quantities of coils with or without paper interleaving. It will produce round, square

or rectangular coils up to 6 in. each in length and up to 4½ in. diameter. As many as 12 smaller coils can be wound simultaneously within the total available winding length of 15 in. at headstock speeds of between 600 and 2,000 r.p.m.

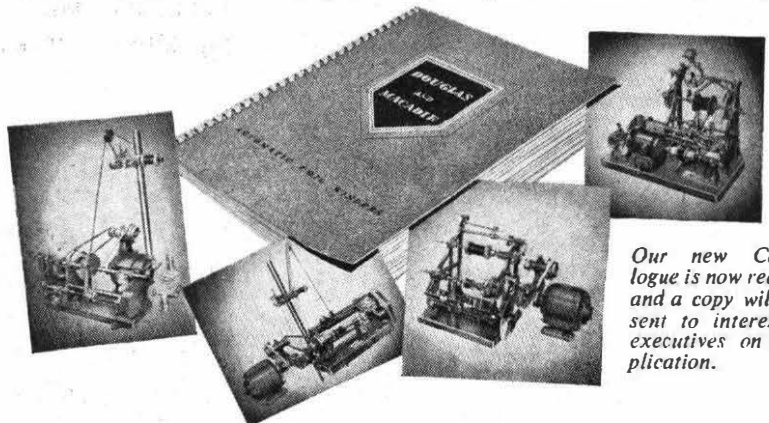

Our new Catalogue is now ready, and a copy will be sent to interested executives on application.

Sole Proprietors and Manufacturers:

AUTOMATIC COIL WINDER & ELECTRICAL EQUIPMENT CO. LTD.
WINDER HOUSE · DOUGLAS STREET · LONDON · S.W.1 Telephone: VICTORIA 3404/9

G.N.T.

MORSEINKERS
MODEL 1515

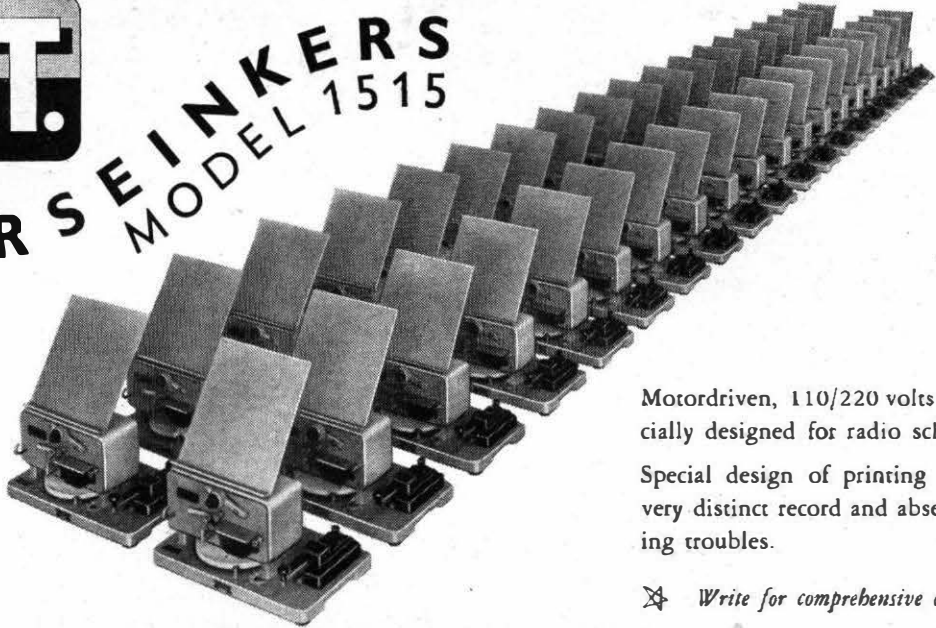

Motordriven, 110/220 volts A.C., especially designed for radio schools.

Special design of printing wheel gives very distinct record and absence of inking troubles.

✧ Write for comprehensive catalogue.

THE GREAT NORTHERN TELEGRAPH COMPANY'S FACTORY

4, SYDHAVNS PLADS
COPENHAGEN SV . DENMARK

LONDON OFFICE: 5, ST. HELENS PLACE
LONDON E.C.3.

**POWER LIGHTING
TELEPHONY**

HACKBRIDGE
Cable Company Limited

KELVIN WORKS, HACKBRIDGE, SURREY
In Association with BRYCE ELECTRIC CONSTRUCTION CO. LTD.
Branches at BIRMINGHAM, BRISTOL, CARDIFF, MANCHESTER, NEWCASTLE, SHEFFIELD

THE PIONEERS



OF METAL

RECTIFICATION

Franklin's famous kite demonstration in 1752 proving that electricity was discharged from and collected by points, quickly opened the way for the exploration and control of this then new force. Now, two centuries later, Westinghouse have perfected the Metal Rectifier for the conversion of current and its introduction has found a demand in hundreds of aspects of the electrical industry. Among Westinghouse rectifier variations are the copper-oxide rectifier and the Westalite selenium compound single double and quadruple voltage rectifiers and germanium crystal diodes. Westinghouse experience and engineers are available on all rectifier problems and particularly for applications not already provided for through the extensive range of . . .



METAL RECTIFIERS

Dept. P.O.1, WESTINGHOUSE BRAKE & SIGNAL CO., LTD., 82 YORK WAY, KING'S CROSS, LONDON, N.1

SULLIVAN & GRIFFITHS
DIRECT READING
VARIABLE CONDENSERS

WITH NOVEL AIR CAPACITANCE
DECADE RANGE EXTENSION

This air dielectric condenser comprises a decade of air capacitance and a continuously variable air condenser thus giving a scale accuracy ten times that of an ordinary variable condenser of the same range.

Thus a decade of capacitance is provided—permanent in value and entirely free from loss, the only loss present in the complete combination of decade and variable condenser being that due to the solid insulating material which is ordinarily employed in the construction of the latter.

The variable condenser has a range of $100\mu\mu\text{F}$ which is extended to $1100\mu\mu\text{F}$ by ten increments of $100\mu\mu\text{F}$, all adjusted with accuracy so that the decade is absolutely direct reading in $\mu\mu\text{F}$, no corrections or calibration being necessary.

Electrical Standards for Research and Industry

Testing and Measuring Apparatus
for Communication Engineering

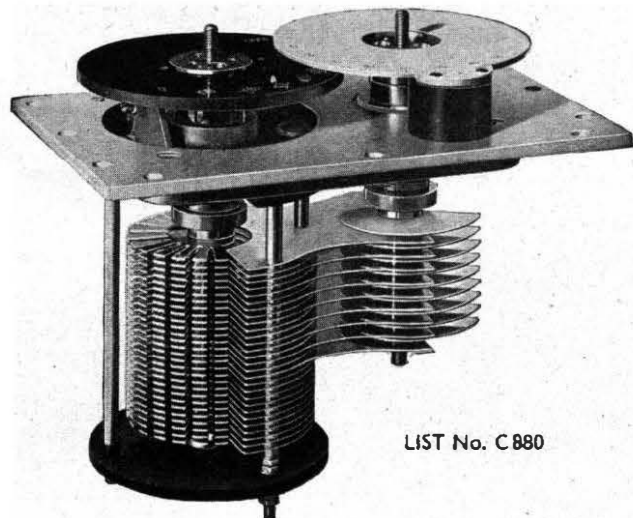

LIST No. C880

H. W. SULLIVAN, LTD., LONDON, S.E. 15.

POWER *behind the lines*

TUNGSTONE PLANTE CELLS are being supplied to the British Post Office and Post and Telegraph Departments in many countries overseas. They conform fully to G.P.O. Standard specifications.

OPEN TYPE CELLS

Similar to the illustration here, these are available in glass and/or lead lined wooden boxes in capacities from 100 a.h. to 5000 a.h.

REPLATALS

We are in a position to supply plates for the replating of any existing Plante Battery.

ENCLOSED TYPE CELLS

As illustrated on the left these are in moulded glass boxes with sealed-in lid. Capacity range from 10 a.h. to 200 a.h.

HIGH VOLTAGE TELEPHONE BATTERIES

Portable Type. Standard layout for 50 volts, in waxed hardwood crates, **exactly to the requirements of the G.P.O.**

Overseas customers are invited to cable or write their enquiries for batteries or parts. Visitors to London are welcome at our offices (just off Fleet Street).



TUNGSTONE *Batteries*

For further particulars write: TUNGSTONE PRODUCTS LIMITED
10 SALISBURY SQUARE · LONDON · E.C.4 · ENGLAND · Cables: "Dilutum" London



TAKE A BIRD'S EYE VIEW

OF THE No. 9A IMPULSE MACHINE

*** an impulse sender for Routers and Testers**

The illustration shows the new No. 9A impulse machine which operates with a speed and frequency accuracy of 0.5% with an input voltage range of 46 to 52 volts. It provides 12 impulses per second in trains of 9 and 11, 8 and 9, and 1 and 10 impulses with 80%, 66.6% or 50% break. The spring contacts operate without bounce. Their accuracy is visibly verifiable on graduated dials.

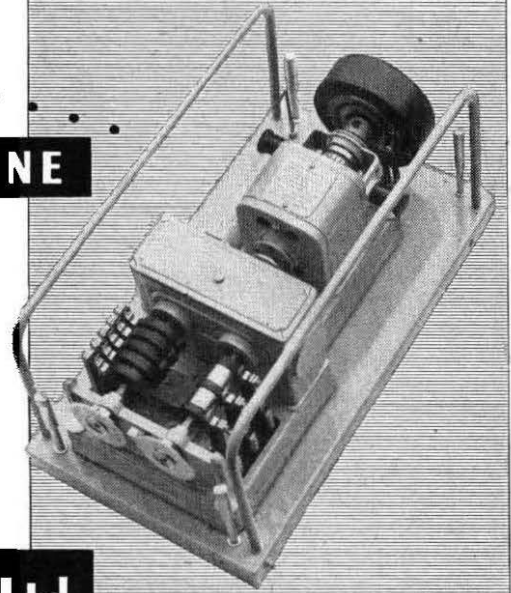

WALTER JONES & Co (Engineers) Ltd.
NEWLANDS PARK · SYDENHAM · LONDON · S.E.26
TEL: SYDenham 6264

AUTOMATIC VOLTAGE REGULATORS by B.P.T

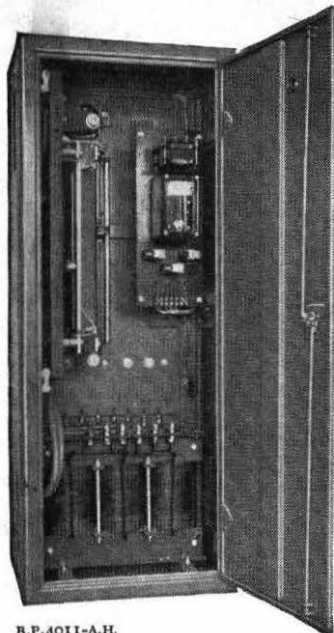

B.P.4011-A.H.

Maintaining a constant voltage unaffected by variation in the supply voltage, frequency, load and load power factor is a problem which can be solved by the aid of our standard range of Automatic Voltage Regulators. For single phase operation there are 11 models from 12½ to 240 amps, for three-phase there are 13 models from 7½ to 150 amps.

Three typical models are illustrated from our standard range of wall or floor mounting types.

TOP 3-phase, air cooled, wall mounting model. Input 440V ± 10%, output 440V ± 1%. 7½ amps.

LEFT 3-phase, air cooled, floor mounting (cubicle) model. Input 440V ± 10%, output 440V ± 1%. 40 amps.

RIGHT Single-phase, air cooled, wall mounting model. Input 250V ± 15%, output 250V ± 1%. 25 amps.

Please write for further information and literature. BP401/9

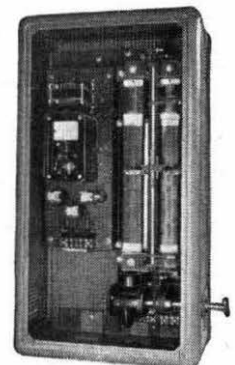
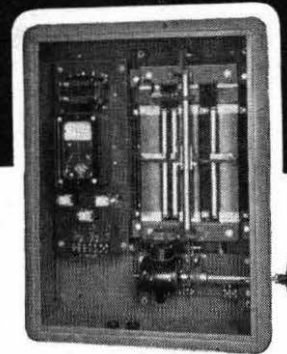

BRITISH POWER TRANSFORMER CO. LTD.

Phone: HOWard 1492 QUEENSWAY, PONDERS END, MIDDLESEX Grams: "Vitrohm Enfield"

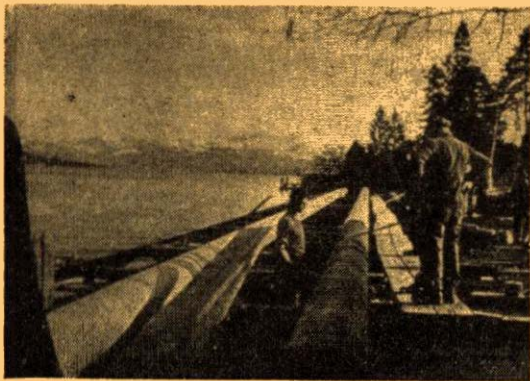

PROTECTION UNDER WATER!

The pipe in the photograph is one of many which have been Denso-protected prior to placing under water—in this instance Lake Zurich.

Of a diameter of 350 mm., individual lengths of 50-60 metres were assembled on the bank, floated into position and sunk.

Necessary joints were made by a diver and then Denso-protected.

The photograph shows the Denso tape actually being applied.

Whether used under water, below or above ground, Denso—an anti-corrosive of proved ability—provides a protection which is full and lasting. Its "cold" application greatly reduces time and labour costs—an important consideration!

The genuine article is manufactured only under this name. Full technical details on request from:



WINN & COALES LIMITED

DENSO HOUSE, CHAPEL ROAD, LONDON, S.E.27

Telephone: GIPsy Hill 4247/8. Telegrams: Denselte, Westnor, London.

SOUND INSTRUCTION by Postal Method

The I.C.S., largest school in the world devoted to spare-time training by the postal method, offers you highly specialised Courses for the following examinations:

P.M.G. Certificates for Wireless Operators.

C. & G. Illumination Engineering (Inter.)

C. & G. Electrical Engineering Practice, Installation and Telecommunications.

Graduateship of the B.I.R.E.

C. & G. Radio Servicing Certificate (R.T.E.B.)

I.C.S. Examination students are coached till successful.

Other Courses meet the requirements of all who desire to qualify for responsible positions in Electric Power, Illumination, Heating and Traction Systems. Equally successful is our instruction for Radio Engineers, Radio Servicemen, and in Elementary Radar and Electronics, Advanced Short-Wave Radio and Television Technology.

Fees are moderate and include *all* books required.

WRITE FOR OUR FREE BOOKLET and state the particular subject or Examination in which you are interested.

Generous Discount to H.M. Forces.

—YOU MAY USE THIS COUPON—

International Correspondence Schools Ltd.

Dept. 165A, International Buildings, Kingsway, London, W.C.2

Please send me, free of charge, your special

booklet on

Name..... Age.....

Address.....

.....



OSCILLOSCOPE - Type 723



- Y Amplifier response flat from D.C. to 5 Mc/s.
- No overloading occurs with full screen deflection over complete frequency range at 2 kV E.H.T.
- Variable E.H.T. voltages of 1, 2 and 4 kV.
- Time base range from 0.5 seconds to 1 micro-second for full screen deflection.
- A 1 cm. deflection ensures rigid synchronisation over whole frequency range.
- Automatic Brilliance Control Circuit.

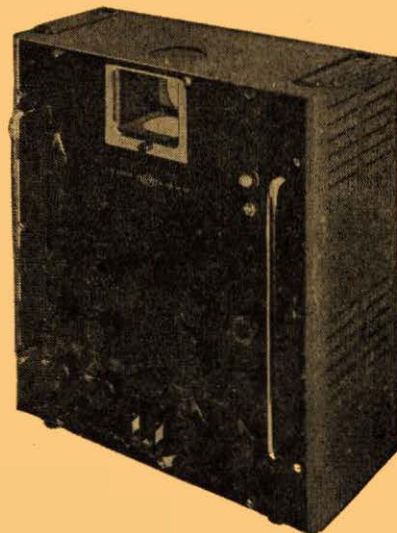

Full details of this or any other Airmec equipment will be provided upon request.

AIRMEC LIMITED

HIGH WYCOMBE · BUCKINGHAMSHIRE · ENGLAND

TEL: HIGH WYCOMBE 2060

CABLES: AIRMEC HIGH WYCOMBE

TELEPHONE DISTRIBUTION

EQUIPMENT

ENGINEERS WHO ARE INTERESTED
IN TELEPHONE DISTRIBUTION EQUIP-
MENT ARE INVITED TO REQUEST
SECTION T.C.13 OF OUR TELECOM-
MUNICATION CABLES CATALOGUE.

TELEPHONE:
SOUTHAMPTON
2141 (5 lines).

PIRELLI & GENERAL
CABLE WORKS, Ltd., SOUTHAMPTON

TELEGRAMS
"PIGEKAYBEL
SOUTHAMPTON"

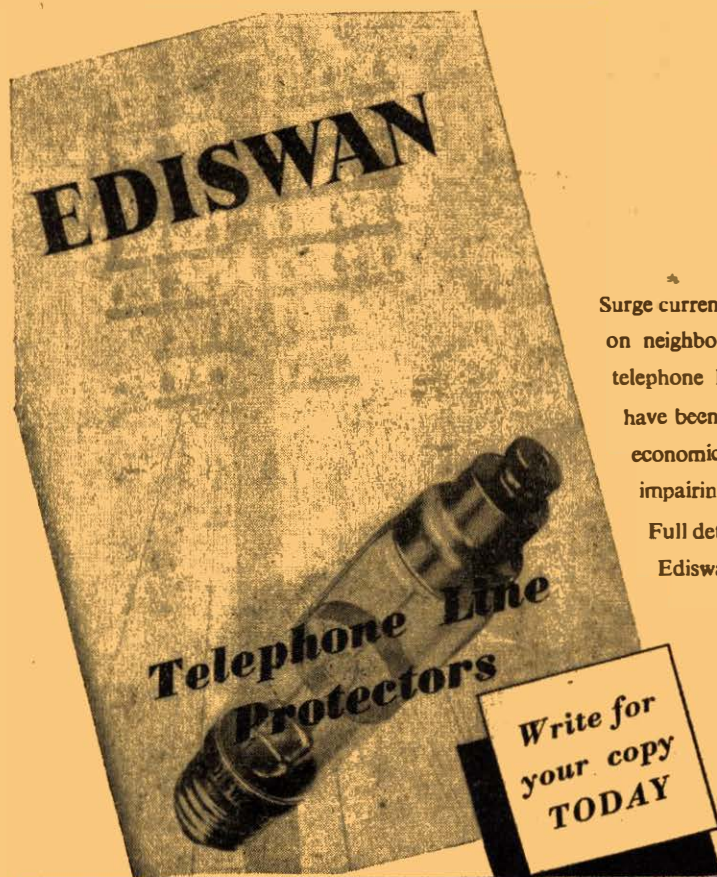

How to protect telephone lines

Surge currents, induced on telephone lines by electric storms or breakdowns on neighbouring power lines, may be effectively controlled by Ediswan telephone line protectors. These special electrode gas discharge tubes have been developed in collaboration with G.P.O. Engineers to provide economical and effective protection for telephone systems without impairing the service.

Full details of these protectors and their application is given in the new Ediswan publication C.1581 which is now available free of charge.

EDISWAN

THE EDISON SWAN ELECTRIC COMPANY, LTD.
155 CHARING CROSS ROAD, LONDON, W.C.2.

Member of the A.E.I. Group of Companies.