

THE POST OFFICE ELECTRICAL ENGINEERS' JOURNAL

Vol. 45

OCTOBER 1952

Part 3

CONTENTS

	PAGE
SINGLE-SIDEBAND MULTI-CHANNEL OPERATION OF SHORT-WAVE POINT-TO-POINT RADIO LINKS. Part 1—General Survey—W. J. Bray, M.Sc.(Eng.), A.M.I.E.E., and D. W. Morris, B.Sc., A.M.I.E.E.	97
TELECOMMUNICATION PROBLEMS ARISING FROM HYDRO-ELECTRIC SCHEMES IN SCOTLAND—H. Fielding, A.M.I.E.E., and E. C. Swain, B.Sc.(Eng.), M.I.E.E.	104
AN IMPROVED GAS DISCHARGE TUBE FOR LINE PROTECTION—F. Jones, B.Sc. (Hons.), A.M.I.E.E.	108
A NEW AUDIO-FREQUENCY OSCILLATOR (OSCILLATOR NO. 22)—R. A. Seymour	111
THE FAULT RECORDER OR DOCKET PRINTING MACHINE—T. F. A. Urben, B.Sc. (Eng.), A.M.I.E.E.	115
C.C.I.F. FIELD TRIALS OF INTERNATIONAL SEMI-AUTOMATIC TELEPHONE OPERATION. Part I—Signalling and Switching Principles—J. V. Miles.	120
A METHOD OF ASSESSING THE EFFECT OF FLEXIBILITY IN DISTRIBUTION NETWORKS—S. D. Mellor, B.Eng., A.M.I.E.E.	125
AN INSTRUMENT FOR TESTING SUBSCRIBERS' SETS IN SITU—R. H. de Wardt, B.Sc.(Eng.), A.C.G.I.	129
THE EUROPEAN V.H.F. BROADCASTING CONFERENCE, STOCKHOLM, 1952	132
A SIMPLE TESTER FOR ADJUSTMENT OF POLARISED RELAYS—M. C. Stone	134
NOTES AND COMMENTS	135
INSTITUTION OF POST OFFICE ELECTRICAL ENGINEERS	135
ASSOCIATE SECTION NOTES	136
REGIONAL NOTES	137
STAFF CHANGES	141
BOOK REVIEWS	103, 114, 119, 124, 133, 140

Price 2/6 net

THE INSTITUTION OF POST OFFICE ELECTRICAL ENGINEERS

How to make certain of your City & Guilds Certificates



"I guarantee tuition until you have passed"

If you consider taking one or the whole series of C. and G. examinations then I can help you. BY POST, in your own time, one of my Telecommunications specialists will coach you until you pass. He will give you individual attention, he will study you and your problems. And you will be surprised how fast you progress. For The Bennett College has specialised in technical subjects since it was founded 50 years ago. My system of personal postal tuition has helped thousands of students through their exams. It can do the same for you.

Send me the coupon to-day. I will send you—without obligation—full information on your subject.

Rep Bennett
GOVERNOR

YOU CAN START ON A BENNETT COURSE FOR ONLY **30/-**

TEAR OUT

with monthly instalments of 15/-

WHICH IS YOUR NEXT STEP?

Preliminary Course
Telecommunications Principles I—V
Telecommunications Practice
Telephone Exchange Systems I—III
Radio I—IV
Telegraphy I & II
Line Transmission I & II
Mathematics for Telecommunications I—V
Radio Servicing Certificate
Television Servicing Certificate
A.M.I. Mech.E.
and many other subjects

The BENNETT COLLEGE

To the Governor, Dept. J24, The Bennett College, Sheffield, England. I would like to have (at no cost) your prospectus and particulars of _____

NAME _____

ADDRESS _____

AGE (if under 21) _____

PLEASE WRITE IN BLOCK LETTERS

VALUABLE FREE BOOK

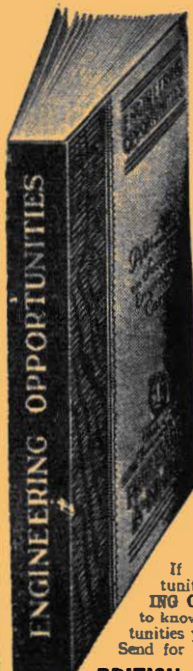

Tells You How to Pass Your C. & G. or Promotion Exam. at First Attempt!

All Post Office Engineering personnel who are anxious to obtain early promotion should at once send for a copy of our handbook "ENGINEERING OPPORTUNITIES," which, among other intensely interesting matter, describes our unique methods of preparation or TECHNICAL APPOINTMENTS IN THE POST OFFICE (Assistant Engineer—New Style and Assistant Traffic Superintendent), CITY AND GUILDS EXAMINATIONS in Principles of Telecommunications (1-5), Radio (1-4), Telephone Exchange Systems (1-3), Telegraphy (1), Line Transmission (1 and 2), Lines Plant Practice (1 and 2), Mathematics for Telecommunications (1-5), Electrical Engineering Practice (Prelim, Inter. and Final), and outlines a wide range of non-examination courses in all branches of Electrical, Mechanical, Civil, Automobile, Aeronautical and Radio Engineering.

Assistant Engineer and Assistant Traffic Superintendent. Open competitions now resumed. Age extensions for established Civil Servants. Ask us for full details

We definitely guarantee "NO PASS—NO FEE"

If you intend to make the most of to-day's opportunities, you cannot afford to miss reading "ENGINEERING OPPORTUNITIES." It tells you everything you want to know to secure advancement, and describes many opportunities you may now be missing through lack of information. Send for your copy to-day—FREE and without obligation.

BRITISH INSTITUTE OF ENGINEERING TECHNOLOGY
369 SHAKESPEARE HOUSE,
17-19 STRATFORD PLACE, LONDON, W.1

BIET

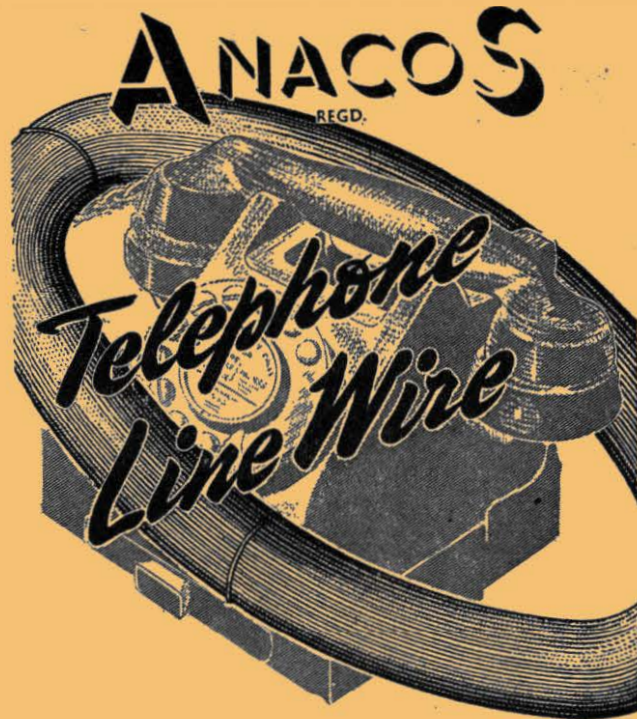

FOR THE RIGHT CONNECTION

FREDERICK SMITH & COMPANY

ANACONDA WORKS, SALFORD, 3, LANCs.

Incorporated in The London Electric Wire Company and Smiths Limited. Associated with The Liverpool Electric Cable Co. Ltd. and Vickers Wire Co. Ltd.

They get around!

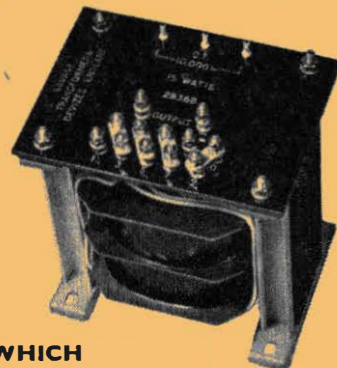

Made by people with a conscience

COUNTRIES IN WHICH SAVAGE TRANSFORMERS ARE IN USE

Spain	Iran	Switzerland	Iraq
Canada	Ireland	Union of S. Africa	Italy
Australia	Jamaica	Belgium	Israel
Malaya	Portugal	Egypt	Libya
Finland	New Zealand	Gibraltar	Mexico
India	Malta	Pakistan	Cyprus
China	Rhodesia	Brazil	Argentina
U.S.A.	Sweden	San Salvador	Sierra Leone

TRANSFORMERS
SAVAGE OF DEVIZES
LIMITED

Savage Transformers Ltd., Nursted Road, Devizes, Wilts. Tel.: Devizes 536

THE POST OFFICE ELECTRICAL ENGINEERS' JOURNAL

Vol. 45

October 1952

Part 3

Single-Sideband Multi-Channel Operation of Short-Wave Point-to-Point Radio Links

W. J. BRAY, M.Sc.(Eng.), A.M.I.E.E. and
D. W. MORRIS, B.Sc., A.M.I.E.E.†

Part I.—General Survey

U.D.C. 621.396.41: 621.396.619.24

Two of the more important trends in the development of short-wave communication systems during recent years have been (a) the increasing use of the single-sideband method of operation and (b) the provision of several telephony or telegraphy channels by means of a single transmitter and receiver. The present article, Part 1 of a series, outlines the principles of s.s.b. working, states the advantages to be gained therefrom and describes the basic techniques that are used for the transmission of multi-channel telephony and telegraphy. Single-sideband transmitting and receiving equipment will be described in detail in subsequent articles dealing with a low-power transmitter drive unit and monitor receiver, a high-power short-wave transmitter, and a short-wave receiver.

INTRODUCTION

THE single-sideband (s.s.b.) method of operation was discovered some thirty years ago, the first application in the field of telecommunications being to carrier telephony on wire lines. Subsequently, in 1927, it was employed on the long-distance radio-telephone link between London and New York, operating on a frequency of about 60 kc/s. In 1930-31 tests were successfully carried out on short-wave links by A. H. Reeves,¹ and in 1936 commercial short-wave links using s.s.b. operation were opened between London and New York. The subsequent extension of this system to other links was delayed by the war, but recent years have seen an increasing use of s.s.b. operation.

At the present time some twelve s.s.b. telephony circuits are in operation between London and New York; s.s.b. operation has also been applied to the short-wave links between London and some eighteen overseas countries, including the Argentine, Australia, Barbados, Bermuda, Brazil, Canada, Ceylon, Cyprus, Israel, Egypt, Greece, W. and S. Africa, Kenya, Persia and the U.S.S.R.

A major step forward in the application of s.s.b. working to and from ships has been carried out by the Post Office Engineering Department with the installation of a 2-kW s.s.b. transmitter and a s.s.b. receiver on board the cable ship H.M.T.S. *Monarch* in 1950; a 0.35-kW s.s.b. transmitter and a s.s.b. receiver have also been installed in R.M.S. *Caronia* by the International Marine Radio Co.

A general survey of the part played by the British Post Office in developing long-distance point-to-point links, with particular reference to the use of s.s.b. techniques, has been given by A. H. Mumford in a paper² presented at the Radio Communication Convention of the Institution of Electrical Engineers in 1947.

THE PRINCIPLES OF SINGLE-SIDEBAND OPERATION

It is a fundamental characteristic of short-wave communication that the audio-frequency signals to be transmitted are made to modulate a "carrier" wave, the

† The authors are, respectively, Assistant Staff Engineer and Senior Executive Engineer, in the Radio Experimental and Development Branch, E.-in-C.'s Office.

¹ References are given at the end of the article.

frequency of which is usually in the range 3 to 30 Mc/s, the carrier frequency used in a given case being determined by the length of the propagation path and the prevailing ionospheric conditions. The modulation process employed in both double-sideband (d.s.b.) and s.s.b. operation is that of amplitude modulation, i.e. variation of the strength of the carrier by the audio-frequency modulating signal. The effect of such amplitude modulation of a carrier, frequency f_c , by a single audio-frequency component, frequency f_a (Fig. 1(a)), is to produce a signal comprising the carrier itself together with two "side-band" components, frequencies $(f_c - f_a)$ and $(f_c + f_a)$, symmetrically placed on either side of the carrier, as shown in Fig. 1(b).

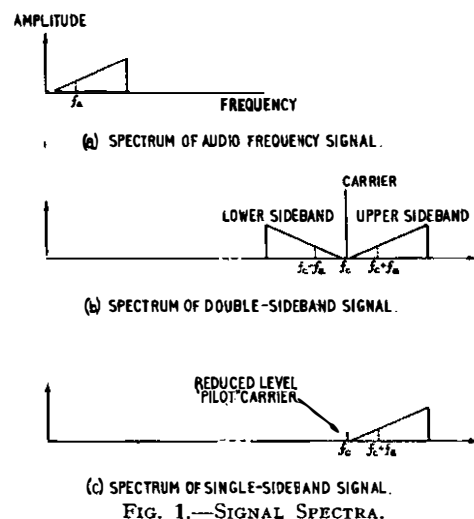

If the audio signal contains several components at different frequencies, then corresponding sideband components are produced. The whole band of frequencies, consisting of the "lower" sideband, the carrier, and the "upper" sideband, if transmitted with no other treatment than uniform amplification, comprises a d.s.b. transmission, similar to those used for broadcasting purposes on medium waves.

It can be seen from the above outline of the d.s.b. method of operation that, since the two sidebands contain identical information, one being the mirror image of the other relative to the carrier, it is unnecessary to transmit both. Furthermore, it can be seen that the carrier by itself does not convey any information since its amplitude and frequency are constant; this leads to the conclusion that its transmission is not essential, since a carrier for demodulation purposes can be introduced locally in the receiver, if need be. Thus, it appears that, having modulated a carrier, the carrier itself and one of the sidebands can be completely suppressed before the signal is transmitted without any reduction in the amount of information conveyed. This mode of operation is known as "single-sideband suppressed-carrier" operation and is employed in long-wave s.s.b. systems; however, for short-wave s.s.b. systems a low-level "pilot" carrier is usually transmitted—the reasons will be discussed later—and the spectrum of the transmission then takes the form shown in Fig. 1(c).

THE ADVANTAGES AND DISADVANTAGES OF SINGLE-SIDEBAND OPERATION

The *advantages* of s.s.b. as compared with d.s.b. operation are as follows:—

- (i) The bandwidth of a s.s.b. transmission is only one-half that of the corresponding d.s.b. transmission; s.s.b. operation thus results in a considerable saving in the frequency spectrum required for any given service.
- (ii) The signal-to-noise ratio is increased by some 9 db. relative to that of the corresponding d.s.b. system, the peak output power of the transmitter being the same in the two cases. Of the 9 db. improvement in signal-to-noise ratio, 6 db. is due to the increase in sideband power output of the s.s.b. transmitter, and a further 3 db. is obtained because the noise power output of a s.s.b. receiver is half that of a d.s.b. receiver of equal gain, since the I.F. bandwidth of the s.s.b. receiver is one-half that of the d.s.b. receiver. The origin of the 6 db. factor can be seen in Fig. 2; sketch (a) shows the transmitter output voltage (or current) wave for s.s.b. and d.s.b. operation (100 per cent. modulation depth), the modulation consisting of a single tone, and the peak-output power being the

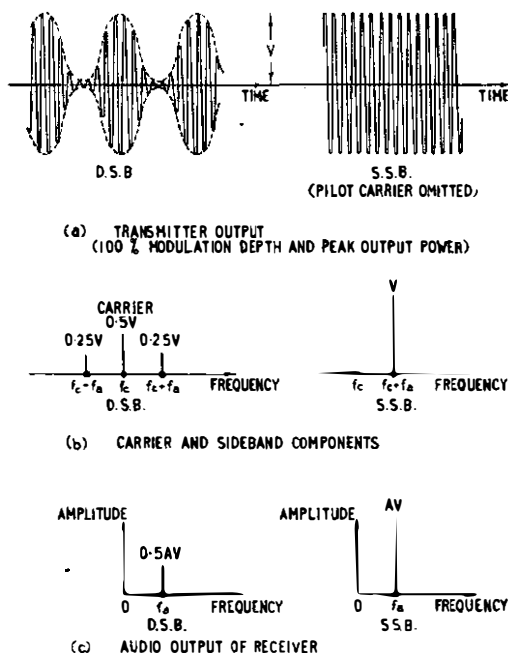

FIG. 2.—COMPARISON OF D.S.B. AND S.S.B. OPERATION.

same in both cases. Fig. 2 (b) shows that the two sideband components in the d.s.b. case are each of amplitude $0.25V$, where V is the peak output voltage; the single component in the s.s.b. case is of amplitude V (the pilot carrier being ignored). If the d.s.b. and s.s.b. signals are received in receivers of equal gain and are detected linearly (a high-level local carrier being used in the s.s.b. case), then the audio signals are $0.5AV$ in the d.s.b. case and AV (i.e. 6 db. higher) in the s.s.b. case, A being a constant proportional to the (equal) gains of the receivers.

- (iii) A useful saving in the main power consumption by the transmitter is effected with s.s.b. operation, since with no audio input the transmitter produces only a small radio-frequency output and therefore consumes very little H.T. power in the high-power Class B amplifier stages, whereas with d.s.b. operation under the same conditions the carrier would be transmitted at approximately one-quarter the normal peak output power, i.e. at half the current (or voltage) corresponding to the peaks of modulation when the modulation depth is 100 per cent.
- (iv) The non-linear distortion present with d.s.b. operation under conditions of multiple-path propagation and selective fading is eliminated with s.s.b. working.³ Consider, for example, the simple case of a 1,000 c/s tone modulation on a carrier; with a d.s.b. system the loss of the carrier at the receiver during a selective fade allows the two sideband components to beat together at the detector and so produce a 2,000 c/s tone, i.e. severe second-order distortion occurs. In the s.s.b. case, only one of the sideband components is present at the receiver input and is demodulated by beating with a high-level carrier in a linear demodulator, so that no distortion occurs. Similar considerations apply when the modulation comprises not a single tone but several audio-frequency components, such as speech, music or multi-channel voice-frequency telegraphy. The freedom of s.s.b. systems from non-linear distortion due to selective fading is of great value when the radio link is used for high-quality signals (e.g. broadcast-signal relaying), for speech that has been passed through privacy equipment, or for multi-channel voice-frequency telegraphy. The effect of non-linear distortion on speech with privacy is to give rise to a serious loss of quality and intelligibility due to the non-harmonic nature of the distortion components in the reproduced speech; the effect of non-linear distortion on multi-channel voice-frequency telegraphy is to give rise to intermodulation between the signals in the various channels and thus to teleprinter errors. Similarly, the absence of non-linear distortion enables a s.s.b. system to provide several telephony channels on a single transmitter and receiver without crosstalk between the channels due to selective fading.

- (v) An important operational advantage of the s.s.b. technique is the flexibility it permits in the use of the transmitting and receiving equipment and the high degree of standardisation that it allows. Thus, using standard s.s.b. transmitters and receivers, it is possible by the addition of audio equipment only to transmit many different types of signal, e.g. commercial quality telephony (3 kc/s bandwidth); high-quality speech and music (6 kc/s bandwidth) for broadcast-relaying purposes; various forms of telephony signals including C.W., M.C.W.; multi-channel V.F. and frequency-shift telegraphy; Hell printer signals; and facsimile signals. This advantage

arises directly from the fact that a s.s.b. system is simply a device for translating a band of audio-frequency signals to any desired part of the high-frequency range (3 to 30 Mc/s) for transmission over a radio link, and back to audio frequency again. An additional advantage in operation is obtained by locating the audio equipment for generating and receiving the various types of signal at the Radio Terminal, where its use can be more conveniently controlled than at the transmitting and receiving stations, the audio signals being transmitted to and from the radio stations by land-lines.

The *disadvantages* of s.s.b. multi-channel operation arise from the increased complexity of the equipment and the higher standard of performance required, as compared with that for d.s.b. operation; the main factors concerned are as follows:—

- (i) High-performance filters, usually of the quartz-crystal type, are required in the transmitter for the production of the s.s.b. signal and in the receiver to separate the sidebands and the carrier.
- (ii) All the amplifier and modulator stages of the transmitter and receiver must be operated linearly if inter-channel crosstalk is to be avoided; this requirement is difficult to combine with high efficiency, and a compromise between efficiency and linearity may be necessary in stages such as the power amplifiers of the transmitter.
- (iii) In the receiver a high-level carrier must be provided for demodulation purposes, the frequency of which must be within a few cycles per sec. of the correct relationship with the sideband frequencies if good quality is to be obtained. This requirement necessitates the use of oscillators with very good frequency stability, both in the transmitters and in the receivers, and, at the present stage of development, a precise automatic-frequency-control system in the receiver.

The advantages of s.s.b. working have been found to outweigh by far the disadvantages for the commercial operation of long-distance point-to-point short-wave radio links; it is to be expected that in the future many more of the main trunk short-wave radio links will be converted to s.s.b. operation.

OUTLINE DESCRIPTION OF A TYPICAL SINGLE-SIDEBAND TRANSMISSION SYSTEM

A brief description of a typical s.s.b. transmission system is given below, while more detailed information relating to equipment designed by the P.O. Engineering Department for such a system will be given in subsequent Parts of the present series. The design of s.s.b. transmitter drives and receivers,⁴ descriptions of equipment developed by the Bell System in the U.S.A.^{5,6} and a useful general survey of s.s.b. operation⁷ have been published elsewhere.

The system to be described is termed an "independent-sideband system" since it is capable of transmitting two independent 6-kc/s channels, one on each side of the carrier frequency. Each 6-kc/s channel may itself be subdivided into two 3-kc/s speech channels or several telegraphy channels, or even a combination of speech and telegraphy channels; such sub-division, which is provided at the Radio Terminal, is considered later.

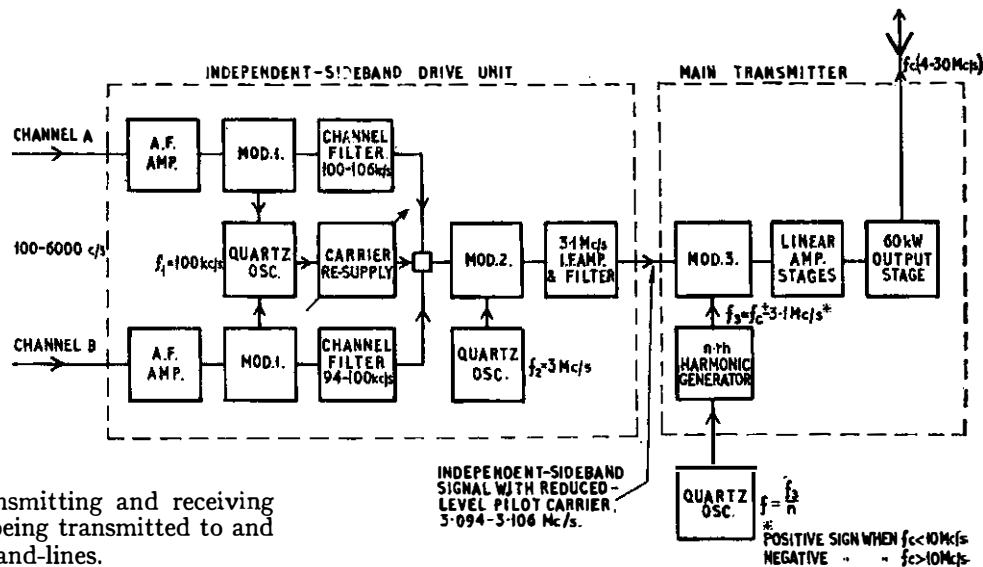

FIG. 3.—BLOCK SCHEMATIC DIAGRAM OF INDEPENDENT-SIDEBAND TRANSMITTER.

Independent-sideband Transmitter.

At the transmitter, see Fig. 3, the audio-frequency signals from the A and B channels (100-6,000 c/s) each modulate a 100-kc/s carrier derived from a quartz-crystal-controlled oscillator; band-pass filters using quartz-crystal resonators then select the upper sideband (100-106 kc/s) in one case, and the lower sideband (94-100 kc/s) in the other. The modulators (MODS. 1) used are nominally balanced; if the balance were perfect no 100-kc/s carrier would be present in the output, but in practice the balance is not perfect and a small amount of carrier leak occurs. The A and B channel sideband signals are combined and passed through a narrow-band 100-kc/s stop filter (not shown in Fig. 3) to remove the residual carrier without attenuating the sidebands. A 100-kc/s carrier at a level of 26 db. below the peak sideband power (the "pilot" carrier) is then added. The residual carrier is removed to ensure that the pilot carrier shall remain at a fixed level relative to the peak sideband level, even though variations in the balance of the modulators occur. Since the automatic gain control of the distant receiver is operated by the pilot carrier, any changes in the pilot carrier level, relative to the peak-sideband level, would result in unnecessary changes in the gain, and therefore in the audio output, of the receiver.

The composite signal in the range 94-106 kc/s is translated in frequency by a second modulator (MOD. 2), using a 3-Mc/s carrier, to the range 3.094 Mc/s-3.106 Mc/s; it is then amplified to a peak power of about 0.25W. The equipment used up to this point is termed the transmitter "drive unit"; it serves as a constant-frequency feed to the main transmitter.

The output of the drive unit is then passed to the main transmitter, where it is translated in frequency by a third modulator (MOD. 3) to the frequency f_c allocated to the service, f_c usually being in the range 4-30 Mc/s. The carrier feed to the third modulator is derived from a quartz-crystal-controlled oscillator, via a harmonic generator, and is at a frequency f_3 such that

$$f_3 = (f_c \pm 3.1) \text{ Mc/s,}$$

where the positive sign applies for f_c below 10 Mc/s and the negative sign for f_c above 10 Mc/s. This convention results in a narrower range of frequencies being required from the carrier generator than would otherwise be the case; for instance, signal frequencies from 4 to 30 Mc/s are produced by means of a carrier generator covering the range 7.1 to 26.9 Mc/s. It should be noted that the A channel is radiated

on the high-frequency side of the pilot carrier for signal frequencies above 10 Mc/s, and on the low-frequency side for signal frequencies below 10 Mc/s.

The output from the third modulator at the frequency f_c is selected and amplified linearly in the high-power stages of the transmitter until, in a large transmitter, a peak power of some 60 kW may be obtained for application to the transmission line and aerial; for many services, however, peak powers of about 20 kW, and even 4 kW in certain cases, are sufficient.

Independent-sideband Receiver.

At the receiving station the received signal, which will usually be in the range 4-30 Mc/s, is first amplified in a tuned R.F. amplifier and is then translated in frequency to 3.1 Mc/s (see Fig. 4). The first frequency-change oscillator

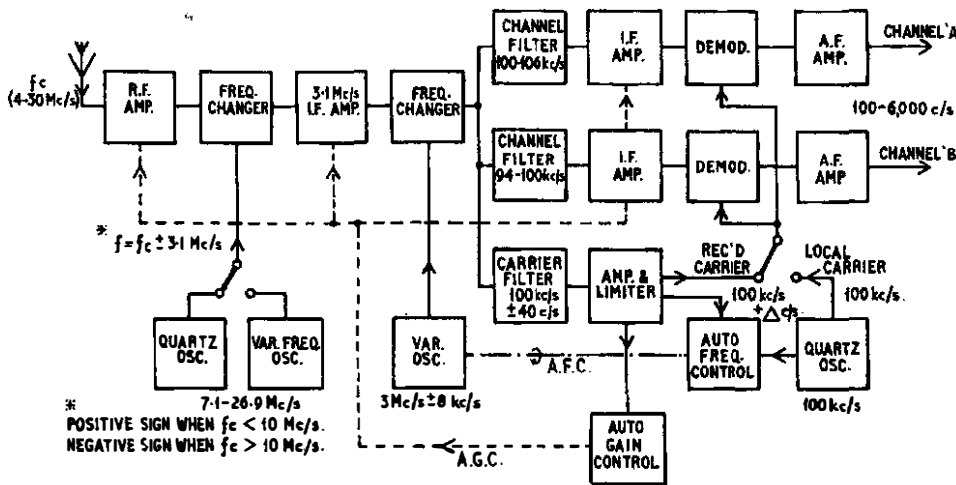

FIG. 4.—BLOCK SCHEMATIC DIAGRAM OF INDEPENDENT-SIDEBAND RECEIVER.

is a quartz-crystal-controlled oscillator, or a stable variable-frequency oscillator when suitable crystals are not available. Since the standard independent-sideband transmission has channel A above the carrier frequency when the latter exceeds 10 Mc/s, and below the carrier frequency when it is below 10 Mc/s, it is arranged that the frequency of the first oscillator in the receiver is below the carrier frequency when the latter exceeds 10 Mc/s, and above the carrier frequency when the latter is below 10 Mc/s, in order that a given channel may always be identified with a given audio output of the receiver.

After amplification at 3.1 Mc/s the signal is again translated in frequency, this time to 100 kc/s, the complete two-channel signal then occupying the band 94-106 kc/s.

Channel filters, similar to those used in the drive unit, select the A and B channel sideband signals which are then amplified and passed to the A and B channel demodulators; the carrier supplied to the demodulators is at 100 kc/s and the audio-frequency output is thus 100-6,000 c/s.

A narrow-band 100-kc/s filter using quartz-crystal resonators selects the 100-kc/s pilot carrier which is amplified and, after detection, operates the automatic gain control (a.g.c.) in the receiver. The amplified pilot carrier, after limiting to remove fading, is also used for automatic frequency control (a.f.c.), i.e. to synchronise the frequency of the received pilot carrier with that of a locally-generated 100-kc/s oscillation, in order that the latter can be used for demodulation purposes. The pilot-carrier frequency (100 kc/s + Δ c/s) is applied with the local 100-kc/s carrier (derived from a quartz-crystal-controlled oscillator) to a beat detector; the resulting beat at Δ c/s operates a two-phase motor. The motor drives a small capacitor which

controls the frequency of the second oscillator, of frequency 3 Mc/s \pm 8 kc/s, in such a way that the frequency difference Δ c/s between the pilot carrier and the local 100-kc/s oscillator is reduced to zero; the motor then stops. Since this form of a.f.c. maintains the received pilot carrier at precisely the same frequency as that of the local 100-kc/s oscillator, either of these 100-kc/s signals can be used for the final demodulation process. In general, the local 100-kc/s oscillator is preferred because of its freedom from noise and rapid variations of phase due to selective fading.

Non-linear Distortion.

In order to realise the full benefits of s.s.b. working, it is essential that non-linear distortion be reduced to a minimum; such distortion arises mainly in the high-power stages of the transmitter due to the fact that these stages are fully loaded in the interests of high efficiency. Non-linear distortion occurs when the amplification is dependent on the level of the audio-frequency input to the transmitter; it results, not only in the distortion of the signal in a given channel, but also in the production of intermodulation components that may fall in adjacent channels and give rise to cross-talk between the channels. In general, it is the third-order intermodulation products (of the type $(2f_1 \pm f_2)$) that are troublesome, since these can fall in adjacent channels; the second-order products (of the type $(f_1 \pm f_2)$) are usually so far removed in frequency from the wanted channels that they can be readily rejected by filters.

The monitoring facilities provided with single-sideband transmitters usually include means for measuring the non-linear distortion introduced by the various stages of the transmitter. The measuring equipment includes a "monitor receiver," by means of which a signal from the output of the drive unit, or from any subsequent stage of the transmitter, can be demodulated and made available as an audio-frequency output. In one form of non-linear distortion test two audio-frequency tones, frequencies f_a and f_b , are applied to the input of one channel of the drive unit, each tone being 6 db. below the level corresponding to the peak loading of the transmitter. The third-order intermodulation product produced in the transmitter is selected in the monitor receiver by a narrow-band filter and translated to audio frequency, the level of the third-order product ($2f_a - f_b$), is then compared with that of either of the two tones (f_a, f_b). A typical requirement is that the ratio of the level of either tone to that of the third-order intermodulation product should exceed 30 db.

An alternative to the two-tone test makes use of a noise generator instead of audio-frequency oscillators.⁸ The "signal" consists of a uniform spectrum of noise in a band, say, 100-6,000 c/s (which can be regarded as a large number of equal-level tones of random phase in that bandwidth) and is applied to the input of one channel of the drive unit, the other channel being unenergised. The levels of noise at the outputs of the two channels of the monitor receiver, one corresponding to the "signal" and the other to the "cross-talk," i.e. the intermodulation products falling in an adjacent channel, are then measured and compared. This method, which will be considered in more detail in Part 2 on the drive unit, has the advantage that it avoids misleading

results which might arise in the two-tone tests due to the fortuitous cancellation of distortion for the particular levels and tone frequencies used for the test.

RADIO TELEPHONY

Four-channel-telephony Working.

In the past it has been usual to accommodate two 3-kc/s wide telephony channels on each single-sideband transmitter and receiver, a gap approximately 3 kc/s wide being left between the speech channels to avoid cross-talk due to third-order intermodulation products. Improvements in the linearity of transmitters have now made it practicable to accommodate four 3-kc/s wide telephony channels on each transmitter and receiver; four such channels are at present in use between London and New York.

Pairs of speech channels, each occupying the band 0.25 to 3 kc/s, are assembled in each of the 6-kc/s sidebands, the transmitted spectrum being as shown in Fig. 5(a). The



(a) ARRANGEMENT OF CHANNELS.

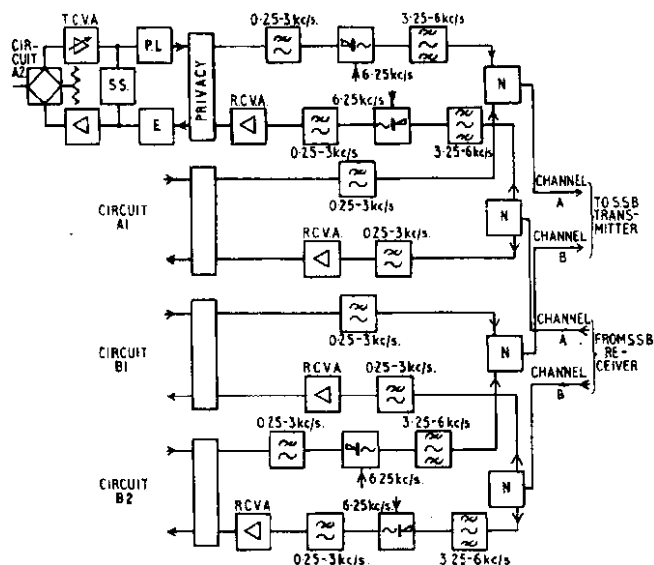

SS = Singing Suppressor. E = Expander.
 PL = Peak Limiter. N = Resistance Dividing Network.
 R.C.V.A. = Receive Constant Volume Amplifier.
 T.C.V.A. = Transmit Constant Volume Amplifier.

(b) BLOCK SCHEMATIC DIAGRAM OF EQUIPMENT AT RADIO TERMINAL.

FIG. 5.—FOUR-CHANNEL RADIO TELEPHONY SYSTEM.

assembly of the speech channels A1, A2 and B1, B2 is carried out at the Radio Terminal and each pair of channels, occupying the band 0.25 to 6 kc/s, is transmitted over the inland line network between the radio stations and the Radio Terminal.

A block schematic of the equipment used at the Radio Terminal for four-channel operation is shown in Fig. 5(b). The speech bands are limited to 0.25 to 3 kc/s, by low-pass filters and are translated to 3.25 to 6 kc/s, where necessary, by balanced selenium rectifier modulators; the 6.25-kc/s carrier supply to the modulators is from a quartz-crystal-controlled oscillator. Constant-volume audio-frequency amplifiers are provided in the transmit and receive paths of the 4-wire circuit in order automatically to adjust the speech levels to suitable values. Peak limiters are inserted in the transmit paths to avoid overloading the transmitter on peaks. It is interesting to note that the peaks of speech

in the four-channel system can be allowed to reach approximately the same level as in a single-channel system without incurring excessive crosstalk; this arises from the intermittent nature of speech and the improbability of the simultaneous occurrence of peaks in two or more channels. There is thus no significant loss of signal-to-noise ratio in going from one- to four-channel operation. The line-up condition used in practice is to apply speech at a level of -10 db. relative to Reference Telephonic Power, at a point in the circuit where the standard level of tone (that for which the transmitter output is 6 db. below the rated peak power output) is 1 mW. Additional information on the constant-volume amplifiers, expanders and singing suppressors, shown in Fig. 5(b), is given elsewhere.⁹

Single-sideband Reception of Double-sideband Telephony Transmissions.

When a d.s.b. transmission is received in the normal d.s.b. type of receiver, severe degradation of the quality due to non-linear distortion often occurs if selective fading is present, as already discussed. The distortion due to selective fading can be overcome by receiving the d.s.b. transmission in a single-sideband receiver, in which one sideband only is selected and is demodulated against a stable high-level carrier, either the original carrier after filtering, amplification and limiting to remove fading and noise, or a local carrier.

Another advantage of this method of receiving a d.s.b. transmission is evident when an interfering signal falls in one of the sidebands of the transmission. Such an interfering signal appears in the audio-frequency output of the receiver if d.s.b. reception is employed, but with an independent-sideband receiver it is possible to eliminate the interfering signal by selecting the sideband which is clear of interference.

In the absence of interference an independent-sideband receiver can be used to receive the two sidebands of a d.s.b. transmission separately. The two audio-frequency outputs, each carrying nominally the same intelligence, will have undergone attenuation of some frequency components relative to others, but the attenuated components are not necessarily of the same frequency in both cases. Thus, by suitably combining the two audio outputs, a frequency-diversity system is obtained which results in a steadier audio output with less frequency-selective fading than is possible with normal d.s.b. reception.

RADIO TELEGRAPHY

Multi-channel V.F. Telegraphy.

The standard equipment used for transmitting multi-channel V.F. telegraphy for teleprinter operation over land lines uses audio-frequency tones of 420 c/s, 540 c/s, 660 c/s and so on, at 120 c/s spacings up to 2,460 c/s, 18 tones in all; each tone is keyed on and off by a D.C. signal from the teleprinter and provides one channel.

Single-tone operation over a short-wave radio link is not satisfactory because of the wide variations of level that occur due to fading; a useful performance can, however, be achieved if the equipment is arranged for two-tone working. In such an arrangement (Fig. 6) two adjacent tones are required for one channel, the tones being keyed by static relays so that one tone indicates "marks" and the other

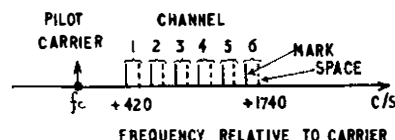

FIG. 6. —ARRANGEMENT OF CHANNELS FOR MULTI-CHANNEL V.F. TELEGRAPH TWO-TONE SYSTEM.

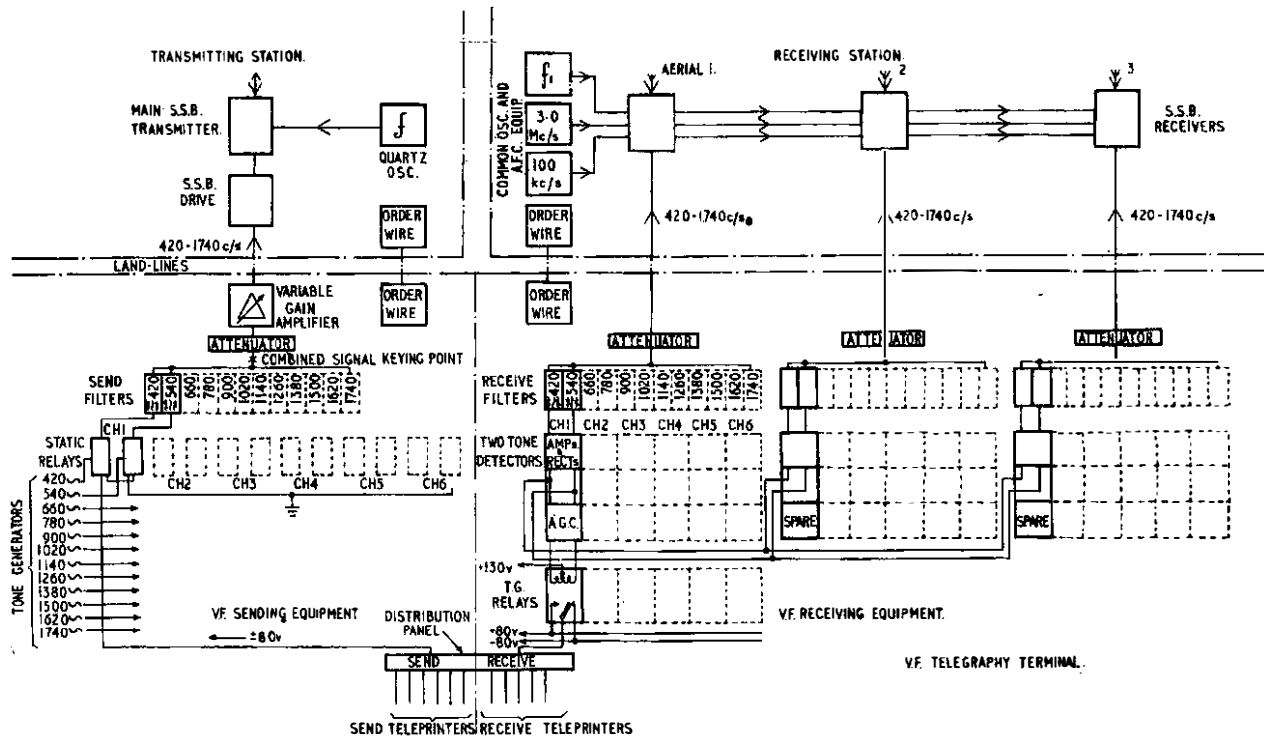

FIG. 7.—SIX-CHANNEL V.F. TELEGRAPHY TWO-TONE SYSTEM (TRIPLE DIVERSITY SPACED-AERIAL RECEPTION).

“spaces.” The keyed and filtered tones from all the telegraph channels are combined and passed by land line from the V.F.-telegraphy terminal to the radio-transmitting station, where they are applied to the input of one channel of a s.s.b. transmitter drive unit. In a 6-channel system the tones are usually transmitted each at a level of -14 db. relative to the peak-power rating of the transmitter. The radiated signals are received on a normal single-sideband receiver; the received tones are then passed by land-line to the distant V.F.-telegraphy terminal, where they are selected by narrow band-pass filters, amplified and detected in two-tone detectors. In a two-tone detector the two tones are separately rectified and the resultant direct voltages operate a push-pull D.C. amplifier in the anode circuit of which a telegraph relay is connected; the tongue of the relay is deflected to mark or space, according to whether the mark or space tone is being received. The telegraph relay then operates a teleprinter, as in the normal inland-telegraph-system practice.

Errors due to selective fading can be minimised by spaced-aerial diversity reception, as shown for example in Fig. 7. Three separate s.s.b. receivers, operating from spaced aeri- als, are employed; the receivers have common first, second (3-Mc/s) and third (100-kc/s) oscillators, and a common a.f.c. system. The receivers can also have a common automatic gain control (a.g.c.), but this is not essential, and individual gain controls with a long time-constant (10 sec.) can be used if desired. Three sets of receive V.F. telegraph equipment are provided and the a.g.c. circuits of corresponding pairs of two-tone detectors are connected in parallel; this arrangement ensures that the strongest mark tone and the strongest space tone are effective in operating the telegraph relay. Under these conditions there is less likelihood of differences of level between the mark and space tones due to selective fading. The effects of selective fading can also be minimised by using frequency-diversity in which two or three mark tones, and two or three space tones, of different frequencies, are allocated to each channel and are keyed simultaneously. Only one receiving aerial and one s.s.b. receiver are then required; however, this arrangement has the disadvantage

that two or three times the radio frequency bandwidth is necessary, as compared with a spaced-aerial system.

Laboratory tests,³ confirmed by field trials on short-wave radio links, show that a frequency-shift system can give improved results as compared with the standard two-tone V.F. system, under conditions of multiple-path transmission and high noise level. A three-channel frequency-shift system, with s.s.b. radio-transmitting and receiving equipment and double-diversity spaced-aerial reception, has been successfully operated jointly by the Post Office and Cable & Wireless, Ltd., between London and Barbados since the beginning of 1949. A shift frequency of 150 c/s is employed, the mid-band channel frequencies being 840, 1,800 and 2,760 c/s. If necessary, the three-channel signals, which are radiated by one s.s.b. transmitter, can be received separately on individual frequency-shift receivers at different destinations, but in the same general direction from the transmitter.

There is little doubt that frequency-shift operation will play an increasingly important part in the transmission of telegraphy over short-wave radio links and that s.s.b. techniques offer considerable advantages in such applications when several channels are to be provided.

Facsimile.

A typical facsimile transmission consists of an audio-frequency tone, the frequency of which varies between 1.5 and 2.3 kc/s as the intensity of the scanned picture varies between white and black. This signal, which contains frequencies lying between about 1.0 and 2.8 kc/s, can be transmitted over a normal s.s.b. radio link, for example, in one of the 3-kc/s wide channels shown in Fig. 5(a).

CONCLUSIONS

The s.s.b. system of operation has many advantages when applied to long-distance short-wave radio links carrying heavy traffic, notably in respect of improved signal-to-noise ratio and freedom from non-linear distortion due to multiple-path transmission. Other outstanding advantages are the high degree of flexibility it offers and the standardisa-

tion of transmitting and receiving equipment that it permits. Many different types of signal, both telephony and telegraphy, can be accommodated by making suitable changes in the audio equipment prior to the transmitter input, and following the receiver output. Because these changes are made at audio frequency the equipments concerned can be located at the Radio Terminal, thus facilitating changes according to varying traffic demands. Furthermore, should it become practicable to reduce the bandwidth required, say, for speech transmission, such reduced bandwidth signals could no doubt be applied to a s.s.b. system without significant changes in the radio transmitting and receiving equipment itself. Thus, the s.s.b. technique makes possible a progressive reduction in bandwidth as the telecommunications art develops, resulting in greater economy in the use of the frequency spectrum and greater traffic handling capacity.

ACKNOWLEDGMENTS

The authors' thanks are due to several colleagues in the Radio Experimental and Development Branch, and to Messrs. A. Cook, J. H. H. Merriman and D. B. Balchin, of the Radio Planning and Provision Branch, for information used in the preparation of this article.

References.

- ¹ A. H. Reeves. "Single-sideband System applied to Short-wave Telephone Links," *Journal I.E.E.*, 1933, Vol. 73, p. 245.
- ² A. H. Mumford. "Long-distance Point-to-Point Communication," *Journal I.E.E.*, 1947, Vol. 94, Part III A, p. 23.
- ³ W. J. Bray, H. G. Lillicrap and F. C. Owen. "The Fading Machine and its Use for the Investigation of the Effects of Frequency-selective Fading," *Journal I.E.E.*, 1947, Vol. 94, Part III A, p. 283.
- ⁴ W. J. Bray, H. G. Lillicrap and W. R. H. Lowry. "The Design of Transmitter Drives and Receivers for Single-Sideband Systems," *Journal I.E.E.*, 1947, Vol. 94, Part III A, p. 298.
- ⁵ G. Rodwin. "The LD-R1 Single-Sideband Radio Receiver," *Bell Laboratories Record*, April, 1951, Vol. 29, No. 4.
- ⁶ N. F. Schlaack. "The LD-T2 Radio Transmitter," *Bell Laboratories Record*, December 1951, Vol. 29, No. 12.
- ⁷ E. T. Wrathall and C. P. Beanland. "The Single-Sideband System of High Frequency Radio Transmission," *Marconi Review*, 1951, Vol. XIV, No. 100.
- ⁸ Nean Lund. "Methods of Measuring Adjacent-Band Radiation from Radio Transmitters," *Proc.I.R.E.*, June, 1951, Vol. 39, No. 6.
- ⁹ C. W. Sowton and D. B. Balchin. "The New London Radio Telephony Terminal," *P.O.F.E.J.*, April, 1951, Vol. 44, p. 25.

Book Reviews

"Transient Electric Currents" (Second Edition, 1952). Hugh H. Skilling, Ph.D. McGraw-Hill Book Co. (Electrical and Electronic Engineering Series). New York. 361 pp. 105 ill. 51s.

This book, the first edition of which appeared in 1937, was designed to show students how to analyse the transient type of circuit problem. It contains an excellent account of the energy transformations associated with transient oscillations in electrical networks, but the mathematical discussion is sometimes careless. For example, the theorem on page 45 which states that the operators p (differentiation with respect to t) and p^{-1} (integration from 0 to t) are commutative when applied to a function $f(t)$ is, in general, not true. For if the operator p^{-1} be applied first to $f(t)$ and is then followed by p , the result will be $f(t)$; but if the process be reversed (by applying p first) the result will be $f(t) - f(0)$ which is different. Thus the operators p and p^{-1} are commutative if, and only if, the function operated on vanishes with t . Consequently the student who wishes to work through the examples given in this book must remember that when p and p^{-1} both occur in an operator the p^{-1} operations must be carried out before the differentiations in order to avoid trouble with $f(0)$.

Since the first edition of this book was published it has become fashionable for engineers to discuss transient circuit problems in terms of the "Laplace transformation." Consequently the author has found it necessary to add a new chapter in the second edition in order to discuss Laplace transforms; in fact he says the object of the second edition is to present the Laplace transformation method to students. Although an effort has been made in this chapter to make the theory intelligible to students the mathematical discussion is superficial and incomplete. Apparently the author realises the sketchy nature of this chapter, for he remarks on page 354 that "Volumes have been written on what is omitted from this chapter."

In the second edition problems have been added to most of the chapters, both to increase variety and to use up-to-date illustrative material. In general, questions are related to practical engineering, and many have been taken from current periodical literature.

"Television, Volumes V and VI." Radio Corporation of America. Volume V, 461 pp. 285 ill.; Volume VI, 422 pp. 285 ill. Each \$2.50 plus \$0.20 postage.

These two volumes set no easy task for the reviewer, for they contain reprints of no less than 38 assorted articles and summaries of a further 30. The articles and summaries have two features in common—they are all written by authors connected with the R.C.A. (Radio Corporation of America); and they are all concerned with television. Within this field, the subjects covered vary very widely but are classified broadly in the table of contents under six headings: Pickup, Transmission, Reception, Ultra-high Frequencies, Colour and General. The first volume contains articles published in 1947-48, while the second covers the years 1949-50.

Perhaps some of the most interesting articles are those dealing with colour television. Volume V contains one describing the R.C.A. "simultaneous" colour television system in which the three colour elements of a picture are transmitted simultaneously in three separate frequency bands. Such a system obviously requires a very wide bandwidth for transmission. Some measure of the rapid progress made in this field is shown by the series of articles in Volume VI, dealing with the more recent R.C.A. "dot-sequential" system, in which the three colours are transmitted in a single frequency band by a sampling method and dots of the three elemental colours are transmitted in sequences. In this way, it is claimed that colour picture signals of a definition comparable with that of a normal black-and-white system can be accommodated in the standard channel bandwidth. Although a great deal of development work is still necessary before the system becomes a practical proposition, we are likely to hear a good deal more about it in the future.

It is perhaps a pity that space has not been found for a full reprint of the article entitled "Television D.C. Component," by K. R. Wendt, of which a summary only is included in Volume V. As the author himself says: "Although important, and one of the oldest of television techniques, the D.C. component is still one of the least understood." Wendt's exposition of the subject which appeared in the *R.C.A. Review* (March 1948) is probably the best that has been written anywhere, and would have been well worth reproduction in full. However, the two volumes will join the four that preceded them as a very useful addition to the bookshelves of any television engineer.

H. J. J.

T. K.

Telecommunication Problems Arising from Hydro-Electric Schemes in Scotland

H. FIELDING, A.M.I.E.E.
E. C. SWAIN, B.Sc.(Eng.), M.I.E.E.

U.D.C. 621.396.823: 621.311.21

In this article the authors outline some of the difficulties experienced on telecommunication circuits in Scotland, due to induction from the transmission and distribution lines erected by the North of Scotland Hydro-Electric Board. The major problem arises from induction at fundamental frequency under conditions of earth fault on a H.V. power line; three methods of protecting telecommunication circuits under such conditions are described.

Introduction.

THE North of Scotland Hydro-Electric Board, constituted under the Hydro-Electric Development (Scotland) Act, 1943, are responsible for the development of all further hydro-electric power and for the transmission and distribution of electricity in an area which was extended by the Electricity Act, 1947, to 21,750 square miles north and west of a line from the Firth of Tay to the Firth of Clyde—about three-quarters of the total area of Scotland.

Under the Act of 1943 the Board are required to prepare and carry out schemes to include the building of reservoirs, dams, aqueducts and tunnels for the collection and storage of water; the construction of access roads; the building of generating and sub-stations, and the erection of transmission and distribution lines. Details of some of the main transmission lines are given in Fig. 1.

The Board's main and subsidiary transmission lines, like those of the British Electricity Authority, are working at 132 kV and 33 kV respectively. Solid earthing of the neutral at each transforming station has been adopted on all main transmission lines. This is now standard practice throughout the country. The Board's 132-kV system is linked to the British Electricity Authority's "grid" at Abernethy,

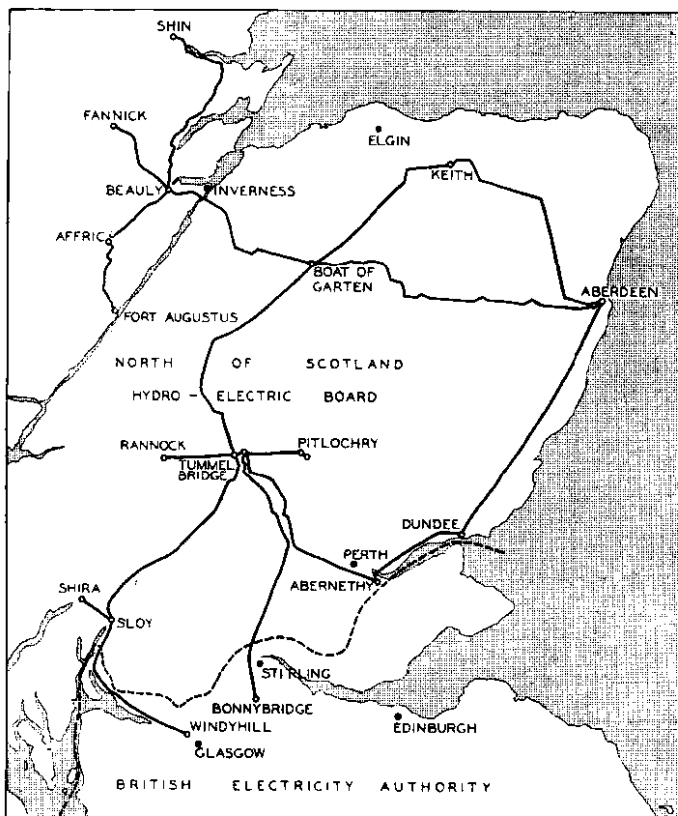

FIG. 1.—ROUTES OF SOME OF THE MAIN TRANSMISSION LINES.

Bonnybridge and Windy Hill (Glasgow). So far, there are no proposals concerning the use of 275-kV or 380-kV transmission lines in the Board's area, and none of the lines have been erected with this development in view.

The Board's distribution schemes follow the present standard practice of the rest of the country; that is, mainly at 11 kV between distribution centres and at normal 3-phase and single-phase low voltage to consumers.

Nature of the Problems.

The problems which arise in the telecommunication service as a result of the Board's work in the north of Scotland are, in the main, similar to those arising in the rest of the country, due to the work of the British Electricity Authority and the Area Electricity Boards. It is the degree of these problems which is much worse in the north of Scotland. There are two reasons for this: (a) the mountainous nature of the country dictates that the most economical arrangement is for the power lines to follow the valleys and hence there is closer parallelism with telecommunication circuits than in less mountainous parts; and (b) the resistivity of the earth in the north of Scotland is much higher than in England. This, again, is due to the mountainous nature of the terrain.

It has been reported¹ that, generally, the mean resistivity of the earth in England and Wales to a depth of 500 ft. is less than 30,000 ohm-cm., as compared with 100,000 ohm-cm. or higher in the north of Scotland. The results of tests made have indicated that in some parts of the north of Scotland the resistivity may be very much higher, e.g. over 500,000 ohm-cm. Similar experiences are reported in the mountainous parts of Norway and Sweden.

The normal problems which arise in the telecommunication service due to the work of the electricity supply authorities are:—

- (1) danger due to physical contact between power and telecommunication lines,
- (2) noise interference and interference with signalling on telecommunication circuits including radio, and
- (3) danger arising from induced voltage in telecommunication circuits when an earth fault occurs on a nearby parallel power line.

Crossings and Proximities.

The conditions concerning the dangers due to physical contact between power and telecommunication lines in the north of Scotland do not differ from those in the rest of the country and normal protection methods have been applied, e.g. cradle guards, the placing underground of the power or the telecommunication line, and the use of P.B.J. insulated wire for low-voltage crossings.

A point of interest arises in regard to telecommunication lines placed underground at a crossing with a high-voltage power line. Because of the high resistivity of the earth, the effects of lightning are much worse than in other parts of the country where the resistivity is low. A short

¹ British Electrical and Allied Industries Research Association (E.R.A.) Reports M/T 32, 33 and 35.

isolated length of underground cable in an otherwise open wire route, is very prone to damage by lightning, and some trouble has been experienced at power crossings of this type. In order to minimise lightning damage, it is now standard practice to use a cable with the sheath insulated from earth at all power crossings in Scotland where the telecommunication line is placed underground. Tough rubber-covered, lead-sheathed, paper-core cable or polythene-sheathed, polythene-insulated cable is used according to the availability. This method has been used for three years now and, to date, no faults due to lightning have been reported.

Noise and Signalling Interference.

The amount of noise interference with telecommunication lines (i.e. induction at voice frequencies under normal operation of the power supply system) due to electricity supply lines is generally small, but, when the Board started to develop electricity supplies in the north of Scotland, it was not known what effect the long, close parallelisms between power and telecommunication lines would have on the working of the telecommunication circuits. Noise interference may affect the speech path or the signalling arrangements including the masking of the normal engaged test. It was expected that the trouble might not be serious and, up to date, this expectation has been realised.

Noise interference may arise when a telecommunication line runs closely parallel to a 3-phase, H.V. power line to which a long single-phase line is connected. The presence of the single-phase connection increases the capacitance to earth of two phases, and the resultant unbalance causes a residual earth current to flow along the power line to the neutral point at the power feeding transformer. If this residual current contains any harmonics within the voice range, noise will be induced into any telecommunication circuit which runs closely parallel to the power line. In one case investigated, the power supply contained harmonics of 550 and 1,250 c/s (and in another case harmonics of 550 and 650 c/s) of sufficient magnitude to cause noise interference with the working of telecommunication circuits. In the one case, it was decided that the noise could be tolerated so long as the overhead telecommunication circuits could be maintained in good order, but, in the other, it may be necessary to fit noise suppression devices to reduce the noise interference to a reasonable value.

A second type of trouble due to noise interference may arise when a large power consumer connected to a long H.V. power line takes a load which causes a flow of harmonics in the power line, e.g. a large rectifier installation or a large installation of A.C./D.C. machines. In such circumstances the harmonic currents are balanced and the induced noise in a parallel telecommunication circuit arises from the different physical separations of the phase wires from the telecommunication wires. In a case investigated in Scotland the noise interference was detected over a very wide area, and on some circuits as far as 35 miles radially (66 route miles) from the consumer's installation. The main complaints of noise interference came from the users of telecommunication circuits which are parallel with another H.V. power line connected to the same feeding transformer as the power consumer and run on the same pylons for a distance of about six miles. The approximate layout of the power and telecommunication systems is shown in Fig. 2. The main interference frequencies are 150, 350, 850 and 950 c/s. Because of the widespread nature of the interference, the noise will ultimately be suppressed at the source using resonant shunts fitted on the A.C./D.C. machines; until these are fitted, noise suppression devices have been connected temporarily in the telecommunication circuits worst affected by the noise.

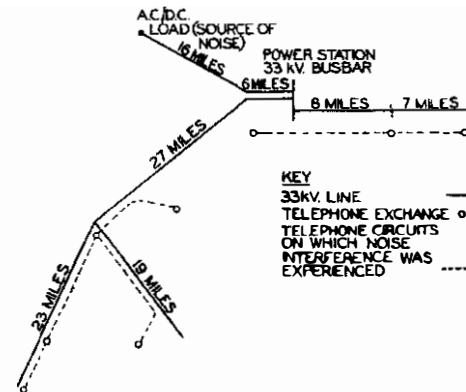

FIG. 2. LAYOUT OF POWER AND TELECOMMUNICATION SYSTEMS WHICH GAVE RISE TO NOISE INTERFERENCE.

Interference with Radio Stations.

A high-voltage power line may, in certain circumstances, cause interference with the working of a radio receiving station by the radiation of noise frequencies, due to corona discharge and other causes, within the frequency band used by the radio station. Any risk of such interference is usually eliminated by keeping high-voltage power lines more than one mile from a radio receiving station (only within the "line of shoot" if the station is directional). In the north of Scotland and particularly in the Islands where the radio link is the normal means of telecommunication, it has often been difficult to keep all high-voltage power lines more than one mile away from a radio station, and much smaller separations have had to be allowed with the consequent greater risk of interference. Only very occasionally, however, has the use of underground cable for the power line proved necessary.

FUNDAMENTAL FREQUENCY INDUCTION

The induction in telecommunication lines of voltage at fundamental frequency under conditions of earth fault on a high-voltage power line has introduced the major problem in connection with the development work of the Board. The mountainous nature of the terrain affects this problem to a much greater degree than it affects any of the others.

The Directives² of the C.C.I.F. regarding the protection of telecommunication lines against the adverse effects of power lines recommend that:—

- (1) "When bare wire overhead circuits, or cable circuits fitted with lightning protectors or with equipment which has in it a direct connection with earth, are concerned, the circuits shall be considered dangerous if the longitudinal induced voltage exceeds 430V.
- (2) "When cable circuits are terminated on transformers and are not earthed and are not fitted with lightning protectors between wire and earth, they shall be considered dangerous if the longitudinal induced voltage exceeds 60 per cent. of the test voltage of the cable and its accessories, viz., transformers and loading coils."

In Great Britain it is the normal practice to require the power undertaking to limit the earth fault current of any power line to such a value that the voltage induced in any telecommunication line will not exceed 430V. When the route of a proposed power line has been decided, the mutual impedance with parallel telecommunication lines is estimated from the theories of Carson and Pollaczek, and the upper limit of the earth fault current determined.³ The effect of earth resistivity on mutual impedance may be seen by considering the values at 50 c/s for earth resistivities of

² C.C.I.F. Directives, Rome Edition 1937, revised at Oslo 1938.

³ P.O.E.E. J., Vol. 26, p. 97.

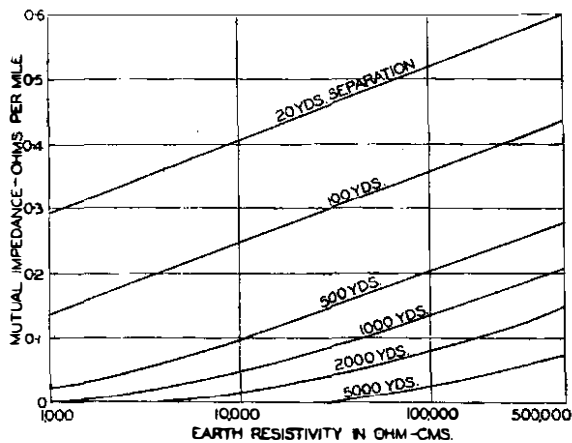

FIG. 3.—MUTUAL IMPEDANCE BETWEEN TWO PARALLEL LINES AS A FUNCTION OF EARTH RESISTIVITY. FREQUENCY 50 c/s.

1,000 ohm-cm. and 200,000 ohm-cm. (see Fig. 3). For a small separation, such as 20 yards, the mutual impedance changes from 0.294 to 0.55 ohms per mile; for intermediate separations, such as 500 yards, it changes from 0.025 to 0.235 ohms per mile; for large separations, such as 5,000 yards, the mutual impedance is negligible for earth resistivities below 30,000 ohm-cm., but rises to 0.044 ohms per mile at 200,000 ohm-cm., a value which cannot be neglected in long exposures. A mean value of earth resistivity of 200,000 ohm-cm. is used in calculations for lines in the north of Scotland.

Based on a maximum induced voltage of 430V, the allowable earth fault currents for the Board's high-voltage lines are often very small, and the values appropriate to their earlier proposals for main transmission lines caused some concern. Briefly, the position was that (a) the adoption of resistance or arc-suppression-coil earthing would be very costly and would prevent certain of the Board's lines being interconnected direct with existing grid lines for the export of power to the British Electricity Authority; and (b) under earth fault conditions a considerable fault current was necessary to ensure quick clearance of the fault in order to guard against system instability.

As regards (a), the cost of inserting transformers at the junctions between the existing and new lines to enable resistance or arc-suppression-coil earthing to be adopted on the Board's lines was prohibitive. In view of these difficulties, it was decided that the more economical scheme would be the adoption of protective measures on the telecommunication circuits. It was possible to ease the position in one or two instances by taking an alternative route for the power line, but the exposures were generally such that with the earth fault currents which the Board estimated at that time, and on the basis of mutual impedance tests or earth resistivity measurements which had been made in the vicinity of the exposures, the position was still serious after allowance had been made for any increased separation it was practicable to obtain. However, some of the fault currents estimated initially by the Board were not achieved when firm details of their installations were finally decided. The lower fault currents, although appreciably easing the position in the most difficult exposures, were still sufficiently high to necessitate special protection measures.

Three practicable methods of applying protection to the telecommunication circuits are described below.

Gas Discharge Tubes.

If a line exposed to induction is connected to earth at each end by earth electrodes of zero resistance, the induced voltage will cause a current to flow such that the voltage drop along the line exactly neutralises the induced voltage;

in other words, the induced voltage is dissipated in the line impedance. In these circumstances the voltage to earth will be zero at all points along the line. In practice, of course, the line cannot be earthed all the time and earth electrodes of zero resistance are unobtainable. Gas discharge tubes are devices for earthing the line when the induced voltage reaches a certain value.

A gas discharge tube consists fundamentally of three tungsten electrodes in a heat-resisting glass envelope which contains a mixture of neon and argon gases. Two electrodes are brought to an Edison screw cap for connection, through a holder, to the wires of a telephone pair. The third electrode is connected to an earth cap. To ensure the presence of free ions at all times, a spot of radioactive compound is fired on to the glass seal of the earth electrode. From a protection point of view the striking voltage of the tubes should be as low as possible, but a limit is set by the voltages normally employed in telephone circuits. Because of this, a lower limit of the order of 150V is necessary. The variation of voltage across the tube during striking and arcing has been investigated.⁴

The simplest application of gas discharge tubes is to provide a tube at each terminal exchange and to connect the earth terminals of the tubes to the exchange earth electrode system. On the induction of a sufficiently high voltage in the telecommunication circuit the tubes break down into arc discharge and pass a current which may be 5 amps., or greater, per line electrode. The rise of potential across a terminal earth electrode will clearly be determined by the resistance of the earth electrode and the total current flowing through it. When the power line is fed from both ends and the neutral point of the line winding of both feeding transformers is earthed, voltages acting in opposite directions will be induced in the telecommunication circuit, if a power line earth fault occurs at an intermediate point in the exposure. With this condition, even if the terminal gas discharge tubes operate, it is possible for a high line-to-earth potential to exist close to the fault. The provision of gas discharge tubes at intermediate points along the route is a safeguard against this type of occurrence. A further reason for providing intermediate tubes is to ensure that the circuits will be protected when they are broken at any point, since it will generally be under these conditions that men will work on the line.

A drawback with gas discharge tube installations when a fairly large number of circuits require protecting and the induced voltage is high, is that low-resistance earth electrode systems are necessary. These low-resistance earth electrode systems are expensive to provide in high resistivity ground; in fact, the greater portion of the cost of providing gas discharge tube installations is usually spent on the provision of earth electrode systems.

Isolating Transformers.

This method consists of dividing each circuit into sections by inserting, at points along the route, transformers with a high breakdown voltage between windings and between each winding and earth. The points on the route are so chosen that the voltage induced in each section will not exceed the required limit. The method has been applied to both overhead and underground circuits, but its use has been restricted for the following reasons:—

- (1) the insertion of the transformers increases the transmission loss,
- (2) the method cannot be used on D.C. signalling and dialling circuits, and
- (3) special arrangements are necessary for insulation testing and fault localisation.

⁴ See this issue, p. 108 *et seq.*

A method of overcoming the second difficulty, using A.C. signalling, has been developed in the Engineering Department* and this may make it possible to use isolating transformers more extensively in future schemes.

Provision of Screening.

For practical purposes the screening factor of a telephone cable sheath, that is the ratio of the voltage actually induced in the cable pairs to the voltage that would be induced in the absence of the sheath, is given by the formula

$$\text{Screening Factor} = \left| \frac{(R_s + Z_E + Z_A) - Z_m}{R_s + Z_E + Z_A} \right| \dots \dots (1)$$

where R_s is the resistance of the sheath, Z_E is the "external" impedance of the sheath-earth return circuit (that is, the impedance due to flux external to the sheath and any armouring), Z_A is the "internal" impedance (that is, the impedance due to flux internal to the sheath and armouring) and Z_m is the mutual impedance between conductors and sheath. This formula assumes that the sheath is in good contact with earth.

For a lead-sheathed telephone cable in earthenware duct, Z_A is very small in comparison with Z_E and for practical purposes Z_m is equal to $(Z_E + Z_A)$. Therefore, in this case the expression for screening factor may be rewritten

$$\text{Screening Factor} = \left| \frac{R_s}{R_s + Z_E} \right| \dots \dots \dots (2)$$

At 50 c/s a nominal value for Z_E is $(0.08 + j1)$ ohms per mile; the reactive part varies slightly with earth resistivity and diameter of cable. For the more usual sizes of lead-sheathed telephone cables the screening effect is relatively small; for example, the screening factors for 1-in. and 1.5-in. diameter cables are 0.9 and 0.8 respectively.

It will be noted from formula (2) that the screening factor could be improved by reducing the resistance of the sheath. The resistivity of aluminium is approximately 1/7th that of lead, and therefore aluminium-sheathed cable would give an appreciable improvement in screening factor. Unfortunately, because of corrosion, it is necessary to insulate the sheath from earth and this has a detrimental effect on the screening factor unless steps are taken to provide low-resistance earth connections to the cable sheath. Improvement of screening factor could also be obtained by providing a lead-sheathed cable with a high conductivity copper screen under the lead sheath or by connecting spare cable pairs to the sheath at a number of points.

Returning to formula (1), appreciable screening may be obtained by armouring the cable or by laying it in cast iron pipe. It is then possible for the value of Z_A to be considerably greater than that of Z_E , although the actual value depends on the screening current in the sheath or pipe. Approximate equality still exists between Z_m and $(Z_E + Z_A)$, although the real part of $(Z_E + Z_A)$ may be slightly greater than that of Z_m , due to iron losses. Laboratory measurements have shown that the screening factor of an armoured telephone cable of 1.55 in. diameter may be better than 0.2 over a wide range of sheath currents. A similar result applied for a 1-in. diameter lead-sheathed cable in cast iron pipe. By providing a cable with a high conductivity undersheath and a special soft iron armouring, an effective screening factor less than 0.1 may be obtained. It will be appreciated that improvement of the screening of existing cables would be very expensive and that this method is generally applicable only with new cables.

* To be described in a later issue.

† P.O.E.E.J., Vol. 41, p. 113.

• P.O.E.E.J., Vol. 42, p. 177.

An Example.

It has not been possible in the space available for this article to include much of the detailed work involved and it is only possible to describe one example. The example chosen concerns the Board's Constructional Scheme No. 9, Tummel-Garry-Bonnybridge. The line which affected the telecommunication plant was the 132-kV line from Tummel Bridge to Clunie.

On the basis of an earth fault current of 1,500 amps., quoted by the Board, it was estimated that the voltage induced in junction circuits between Tummel Bridge and Pitlochry would be of the order of 1,300V. The mutual impedance had been derived from the results of tests carried out using a 33-kV line between Rannoch and Forfar which followed substantially the same route as the proposed 132-kV line.⁵ Gas discharge tube protection was proposed, the scheme involving the provision of six 9.5-ohm earth electrodes at points along the route. Gas discharge tubes were also to be fitted in Tummel Bridge and Pitlochry exchanges. The resistance of the earth electrode system at Pitlochry was sufficiently low, but that at Tummel Bridge required reduction from 200 ohms to approximately 9.5 ohms. In providing the earth electrodes, advantage was taken of any buried metalwork, such as local water pipes which were available, but even so it was not easy to obtain the required low resistance. Generally, more than 200 yards of buried earth wire was required at each of the six points along the route. The land surrounding Tummel Bridge exchange is very rocky and there is no underground cable system leaving the exchange. To reduce the exchange earth electrode system to the required value it was necessary to lay 900 yards of earth wire, even though advantage was taken of a buried water pipe.

Another example of the provision of low-resistance earth electrodes, where the earth wire was laid in a loch, is described in a previous issue.⁶

It is interesting to note that, although protection has been provided on the junction route between Tummel Bridge and Pitlochry (and also between Tummel Bridge and Bridge of Gaur), trouble has been experienced on these junctions on more than one occasion. The trouble, which is generally in the form of blown fuses and damaged relay set barretters, usually coincides with earth faults on the 33-kV Rannoch-Forfar line which, as mentioned above, follows approximately the same route as the 132-kV line. The neutral point of the 33-kV system is earthed at Rannoch through a 190-ohm resistor, which limits the earth fault current to a value less than 100 amps. As the measured value of mutual impedance between Bridge of Gaur and Kinloch Rannoch is 2.1 ohms, and between Kinloch Rannoch and Pitlochry 4.7 ohms, and because of the protection on the junctions, the voltage induced by the earth fault current on the 33-kV line should be insufficient to cause the trouble. It appears likely, however, that with the high value of earthing resistor the very rapid decay of the unidirectional component of the earth fault current may be the cause of the difficulty.

CONCLUSION

There is, at present, a Bill before Parliament seeking to increase the Board's authority to borrow capital amounting to £200,000,000. Their present authority is £100,000,000, of which £94,000,000 has been expended so far. It is apparent, therefore, that the Board's development work is likely to continue at a high rate and that the telecommunication problems will not decrease.

An Improved Gas Discharge Tube for Line Protection

F. JONES, B.Sc.(Hons.), A.M.I.E.E.†

U.D.C. 621.316.933.6

Hitherto, gas discharge tubes for protecting telephone lines against induced voltages from nearby power lines have been used in two ratings, namely, 1 A and 10 A. A new tube has now been developed, rated at 2-10 A, for surge currents up to 16 A per electrode, for which the delay time in striking has been reduced to about one-tenth. Some improvement has also been obtained in the arc characteristics.

Introduction.

Post Office lines may be subject to induced voltages, either from earth faults on nearby power systems or from lightning strokes in their neighbourhood. High voltages of short duration may appear on the lines and could be dangerous to the lines and their associated equipment, and to persons in contact with the lines at the time. Consequently, protective measures are taken on routes which are particularly liable to induction. One of the ways of reducing the voltage of a circuit pair to earth is to connect three-electrode gas discharge tubes, in accordance with a predetermined plan, to the wires and to earth. When the voltage between the line and the earth electrodes exceeds the breakdown voltage, the tube strikes and reduces the voltage of the wires to earth to a value depending on the characteristics of the tube and the resistance of the earth connection. It can be ensured by suitable arrangements that the line voltage to earth does not exceed a safe value.

An ideal characteristic for the tube would be that breakdown takes place immediately the nominal breakdown voltage is reached, and that the voltage developed across the tube, after breakdown, is zero. The breakdown of the gas at the low pressures used in these tubes, is, however, subject to two effects which reduce their efficiency for protection. In the first place, there is a time delay in the initiation of breakdown, which, with a rapidly rising voltage front, permits voltages considerably in excess of the nominal breakdown voltage to develop across the tube. Secondly, there is a tendency for the discharge to occur in the form of a glow instead of an arc, and since glow voltages are much higher than arc voltages, glow discharges are undesirable. It is evident that the characteristics of discharge tubes are important in that large residual voltages may be permitted to appear on a telephone line.

A secondary aspect of the breakdown of gas discharge tubes is that there can be considerable variability in both the time delay and in the arcing performance. Effectively, each wire of a circuit pair is connected to earth via a separate discharge path, and if one path breaks down before the other, or if the one path is in glow discharge and the other in arc discharge, transverse voltages appear on the circuit pair. These voltages can be quite large, particularly in comparison with signal voltages, with the resulting danger of acoustic shock.

As a result of these considerations, an investigation of gas discharge tubes was undertaken to determine the maximum delay time in striking, and the arcing performance after striking.

Measurement of Discharge-Tube Characteristics.

It is difficult to arrive at representative conditions to apply when measuring discharge-tube characteristics. The voltage which will be developed across a tube due to a delay in striking will depend on the rate of rise of the voltage applied, and it has been found that arc or glow discharge is dependent on the current flowing in the tube. The rate of rise of voltage in induced surges from power lines depends on a number of factors, namely, the magni-

tude and initial phase of the fault current, proximity to the power line, the amount of shielding present, earth resistivity and the length of exposure. The current through the tube will also depend on a number of factors, including the magnitude of the induced voltage, the length and characteristics of the telephone line, and the resistance of the earthing system for the tubes. In the case of induction from near lightning strokes, the rise time and magnitude of the voltage will vary considerably with distance and the amount of charge neutralised in the stroke.

In arriving at the testing conditions used, severe conditions in which a tube may need to operate were considered. Such conditions are obtained when large voltages are induced and cause small currents to flow in a tube and line system. In applying these to tube measurements the voltage should be switched in at its peak but this is exacting on test equipment, and switching in at zero voltage is preferable. It appeared advisable, therefore, to measure tubes with two separate test conditions instead. These were, (a) a large voltage applied at mains frequency and switched in at zero-voltage phase, and (b) a D.C. impulse with a high rate of voltage rise. The former represents steady state power line induction, and the latter, the transient voltage fronts of power line induction and of voltage surges from near lightning strokes.

The values of voltages used were, for test (a), a voltage of 2 kV R.M.S. at mains frequency with a tube current of 4 A, and a voltage of 1 kV R.M.S. with a tube current of 0.5 A. They were applied for a few cycles beginning at zero-voltage phase. For (b), an impulse with 0.25 milliseconds rise time, and decay time to half value of 12.5 milliseconds was used. The voltage impulse used is shown in Fig. 1.

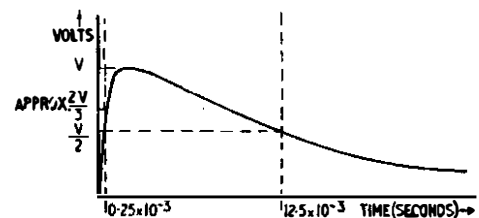

FIG. 1.—WAVEFORM OF D.C. IMPULSE USED IN TESTING.

The circuit used for applying pulses of voltage at mains frequency is given in Fig. 2. A high-voltage transformer was connected to the mains supply through a "variac" for adjusting the output voltage, and a polarity reversal switch

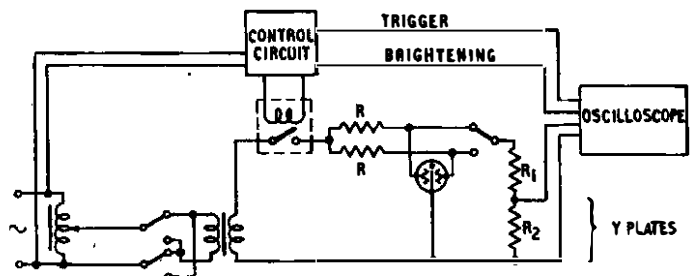

FIG. 2.—GAS DISCHARGE TUBE TEST CIRCUIT.

† Senior Executive Engineer, Post Office Research Station.

which selects the polarity of the first half cycle applied to the tube. The switch was necessary since a discharge tube response is asymmetric with respect to voltage. The discharge tube is switched on to the transformer secondary by a vacuum relay, which is magnetically controlled. The relay is closed by a control circuit at zero-voltage phase for a few cycles. The tube circuit is arranged to pass current through both line electrodes, the current value being adjusted by the resistors R . The potential divider R_1, R_2 provides a convenient voltage for viewing the waveform on an oscilloscope and can be switched to either line electrode. A single-stroke action of the oscilloscope time base was used, the triggering pulse, and also a beam-brightening pulse being obtained from the control circuit.

The circuit for impulse generation and measurement was conventional.

In both types of measurement, photographs were taken of the waveform displayed in order to estimate the magnitude of the voltages developed, when values were required, but the waveform was also easily seen and rough estimates of the voltages present could be made visually.

Characteristics of 1-A and 10-A Tubes.

The two types of gas discharge tube previously in use are similar in construction except for the gauge of the tungsten wires forming the electrodes. In a 1-A tube the electrode diameter is nominally 0.025 in., and in the 10-A tube is nominally 0.06 in. The gas filling is a mixture of neon and argon in proportions selected by the manufacturer. A gas pressure of 6 in. of mercury is used. To facilitate early breakdown of the gas, a small amount of radium sulphide in a cellulose acetate binder is spotted on the outside of the glass envelope.

Representative waveforms of the voltages obtained across the electrodes of these tubes are shown in Fig. 3, for the following conditions:—

- (a) 1-A tube—2 kV R.M.S., 4-A surge.
- (b) 1-A tube—1 kV R.M.S., 0.5-A surge.
- (c) 10-A tube—2 kV R.M.S., 4-A surge.

It is seen that with a current of 4 A in the 1-A tube, a good arc characteristic is obtained, but that the initial delay in striking can be considerable. With a current of 0.5 A in this tube, discharge is mainly in the glow condition. Further, with a current of 4 A in the 10-A tube, there is again an initial delay in striking and a tendency for the discharge to break into glow.

From these and many similar results, it was inferred that, (a) the initial time delay is not related to the electrode size, but is largely dependent on the initial state of the gas, and (b), that the arc characteristic is related to the electrode size and to the current flowing in the tube.

Experiments were also made to examine whether these waveforms were appreciably modified by varying the gas pressure in the tubes. It was found that the pressure of the gas is immaterial in the range 4 to 24 in. of mercury.

For a better understanding of these findings, it is necessary to examine the theory of gaseous breakdown. Although the mechanism of breakdown is still imperfectly understood^{1,2}, sufficient information is available to substantiate the conclusions (a) and (b). The basic equation for gaseous conduction, originated by Townsend, may be written as

$$n = n_0 e^{\alpha l} / (1 - \gamma e^{\alpha l})$$

where n is the number of electrons available to give conduction, n_0 is the number of electrons available prior to applying a voltage stress, α is the number of electrons created by the advance of one electron unit distance in the direction of the field, and depends on the electric stress, l

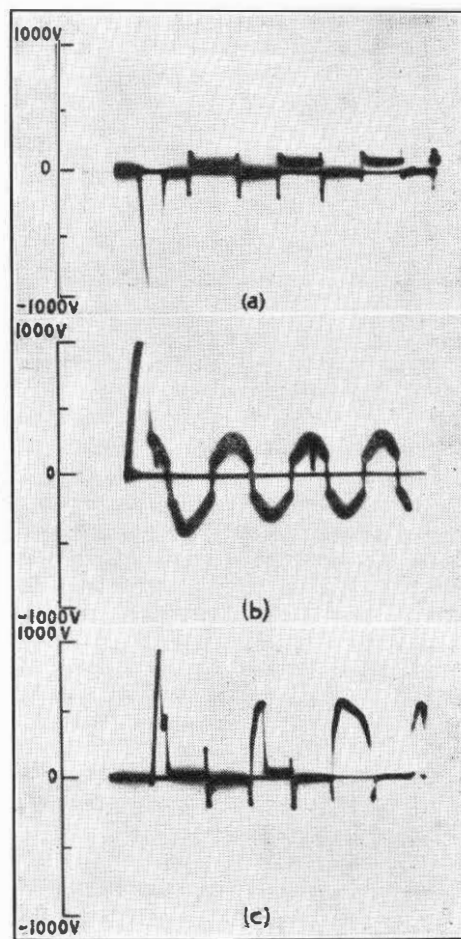

FIG. 3.—TYPICAL WAVEFORMS ACROSS OLD TYPE GAS DISCHARGE TUBES,

- (a) 1 amp. tube, 4 amp. current.
- (b) 1 amp. tube, ½ amp. current.
- (c) 10 amp. tube, 4 amp. current.

is the distance between electrodes, and γ is a factor to which a number of interpretations have been given. At low gas pressures, it has been stated² that γ is the chance that a positive ion will liberate an electron from the negative electrode. From this equation it is seen that the criterion of breakdown is $\gamma e^{\alpha l} = 1$, the voltage being that which gives the appropriate value of α .

A physical picture represented by this criterion is that since $e^{\alpha l}$ is the number of electrons created by one electron starting at the cathode electrode and is also the number of positive ions created, then $\gamma e^{\alpha l} = 1$ indicates a certainty that one further electron will be released by positive ions at the cathode. The discharge is then self sustaining. Glow discharge is therefore satisfactorily explained.

In a gas discharge tube, used for protection, the voltage stress is greater near the electrodes, and in considering the initiation of breakdown, it is very probable that an electron, originating a discharge at the minimum breakdown voltage, starts from a position very close to the negative electrode. Since the electrodes are initially cold, the originating electron is most likely to be present in the gas. The free electrons present in the gas will be randomly distributed, so that if only a few exist, the chance that one is favourably placed to start a discharge at minimum voltage will be small. As the over-voltage between the electrodes rises, the gas volume in which an electron can be favourably placed is increased until at some value dependent on the number of free electrons in the gas, breakdown is certain. On this basis it is evident that the maximum delay time in striking is dependent on the initial state of ionisation of the gas.

¹ "The Mechanism of the Electric Spark." Loeb and Meek. Oxford University Press.

² "Modern Physics." Wilson. Blackie & Sons, Ltd.

When breakdown has occurred in a gas, the initial discharge is in the glow condition. The negative electrode is being bombarded by positive ions, however, and with an appreciable current density, its temperature will rise. Electrons are more readily released, and if the rise in temperature is sufficient, then the discharge will change from glow to arc. The arc discharge is, however, also affected by the space charge distribution of ions immediately outside the cathode, so that a rise in temperature of the electrode does not entirely account for a transition from glow to arc. A temperature rise is, nevertheless, an appreciable factor in causing transition to arc and it may be anticipated that the size of the electrodes and the amount of current flowing in the tube appreciably influences the formation of arcs in discharge tubes. It may also be inferred that materials which readily emit electrons, that is, of low work function, will aid arc formation.

Development and Performance of a 2/10-A Tube.

Early in the development work on new tubes, it was decided that two sizes of tube were undesirable. The nominal 1-A tube can carry surge currents of about 10 A, and, even with worst induction exposures, a maximum current of no more than 16 A is anticipated. In view of this, and because the smaller electrode size facilitates the striking of an arc, the 1-A tube was chosen for development. The experimental work on electrodes was subsequently concerned with the size and shape of the electrode. The wire diameter was increased from 0.025 in. to 0.035 in. and various tip shapes were considered. These were:

- (a) square end, cylindrical electrodes.
- (b) tapered to approx. 2-mil. and $1\frac{1}{2}$ -mil. radii.
- (c) ball end.

Investigation of the glow and arc characteristics showed the performances of the square electrodes to be slightly superior to the other shapes for arc formation. To check the suitability of the electrodes for heavy currents, 10-A currents at mains frequency were passed through one electrode pair for two seconds. The tapered electrodes were damaged, severely in the case of the taper to $1\frac{1}{2}$ -mil. radius. Square-end and ball-end electrodes were not affected. The square-end electrode was therefore adopted.

To decrease the initial delay in striking, experiments were made with larger amounts of the radioactive material. Initial experiments were made with increased amounts applied to the outside of the glass envelope and showed that some reduction in time delay may be obtained. Placing the radioactive compound inside the envelope further improved the speed of striking and in the final design of the tube it was fired on to the glass seal of the earth electrode, using a siliceous binder.

The waveforms of the voltages which exist across these tubes are shown in Fig. 4, for the conditions:—

- (a) 2 kV R.M.S., 4-A surge.
- (b) 1 kV R.M.S., 0.5-A surge.

It is seen that there is an improvement in the time delay in striking and in the arc characteristics by comparison with existing tubes. The time delays in striking for the majority of the new tubes are less than 0.8 milliseconds with 2 kV R.M.S. applied at zero phase. These values compare with times up to about 10 milliseconds with the original tubes.

Further measurements were then made on tubes in their final form to obtain the performance to rapidly rising voltages. Ten tubes were each subjected to 20 impulses of the waveform already specified and the peak voltages developed were observed. These voltages ranged in value from approximately the glow voltage up to 3 kV. In the total of 200 impulses, 30 voltage "spikes" in the region of 2 kV and above were noted. On the basis of these measurements it is considered that little danger to personnel exists

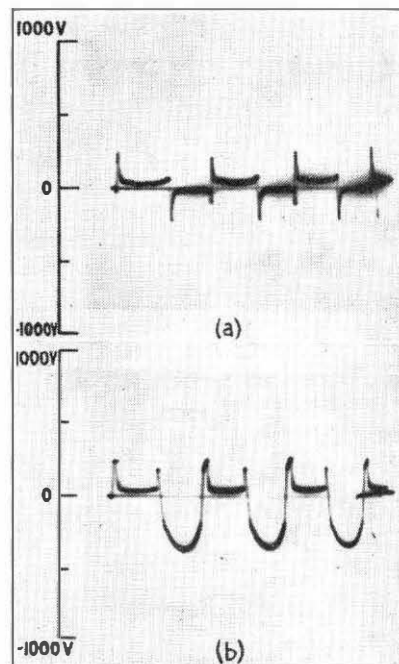

FIG. 4.—TYPICAL WAVEFORMS ACROSS NEW TYPE GAS-DISCHARGE TUBES.

- (a) 2-10 amp. tube. 4 amp. current.
- (b) 2-10 amp. tube. $\frac{1}{2}$ amp. current.

because the duration of the high voltage will be short. Some danger of plant breakdown exists, but when the possibility of occurrence of such impulses is also taken into account, it is considered that the danger is not significant.

Life of the 2/10-A Tube to Heavy Current Surges.

Measurements have been made on some of the redesigned tubes to estimate their performance with repeated heavy current surges. Tests simulating near lightning and induction surges were made.

The criterion of tube failure was initially to be a degeneration of the voltage waveform across an electrode pair, but it was found that appreciable separation could occur without marked degeneration of the waveform. The criterion of life used was consequently an increase in separation of the electrodes by 1-2 mm.

Nearby lightning strokes were simulated by discharging a 10- μ F capacitor through an electrode pair. Two discharges, one through each line electrode, were made to simulate one surge. Two tubes survived 20 surges at an energy level of 500 joules, and two tubes survived 50 surges at 250 joules.

Heavy induction surges were simulated by passing a 15-A current at mains frequency for 10 cycles through each line electrode; two of these surges were made to simulate one practical case of induction, since facilities for passing a 30-A current were not available. Two tubes were tested and a life of about 100 surges was obtained on both.

Acknowledgments.

The author is indebted to a number of the past and present members of the group engaged on this development work, in particular to Mr. I. F. McDiarmid for the control circuit used in testing tubes, and to Mr. G. Sparkes for the numerous measurements made. Acknowledgment is also due to Mr. C. E. Palmer Jones, who was responsible for the work at the time, to Construction Branch for assistance in details of the application of tubes and the field conditions in which they operate, and also to the Edison Swan Co. Ltd., for co-operation in the construction and supply of experimental tubes.

A New Audio-Frequency Oscillator (Oscillator No. 22)

R. A. SEYMOUR†

U.D.C. 621.396.615.029.3

The author gives a brief account of the Oscillator No. 22 developed for audio-frequency testing in repeater stations. The oscillator provides 24 fixed frequencies in the range 30 c/s to 16 kc/s, the frequency and amplitude being controlled by switches. Performance data are quoted which show satisfactory stability in frequency and output level, with low harmonic and noise content.

Introduction.

The Oscillator 22 has been designed to meet present-day requirements for audio repeater station maintenance. Ease of operation, simple maintenance, and suitability for large-scale production have been the principal considerations. The instrument is a resistance-capacitance, lamp-controlled oscillator operated from normal repeater station power supplies, and provides 24 fixed frequencies in the range 30 c/s-16 kc/s; the maximum output power is +10 db. relative to 1 mW into a 600-ohm load. Both frequency and amplitude are controlled in steps by wafer switches. The oscillator (illustrated in Fig. 1) has its components assembled on a mounting plate 19 in. × 14 in. with a rear cover depth of 7½ in.

Basic Design Considerations.

The fundamental circuit of this oscillator is of the form shown in Fig. 2 and consists of a three-stage RC-coupled

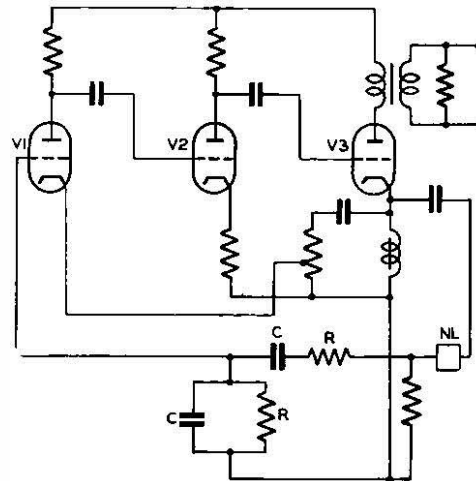

FIG. 2.—BASIC CIRCUIT OF OSCILLATOR No. 22.

high-gain amplifier, with overall negative feedback from the cathode of V3 to the cathode of V1, and positive feedback from the cathode of V3, via the thermal amplitude control NL and the frequency control network RC, to the grid of V1. The voltage gain of the amplifier from the grid of V1 to the cathode of V3 with negative feedback is nominally 16 db., while the gain reduction due to feedback is of the order of 28 db. Fig. 3 shows the phase-shift/frequency and voltage

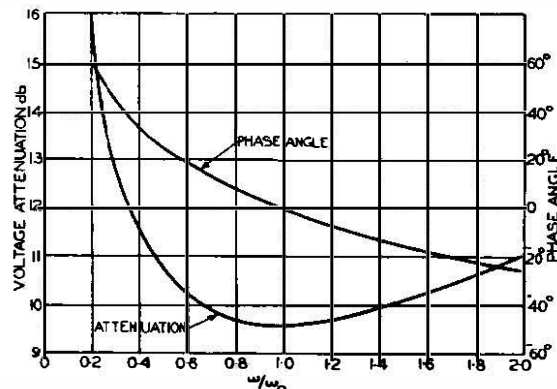

FIG. 3.—ATTENUATION AND PHASE ANGLE/FREQUENCY CHARACTERISTIC OF FREQUENCY CONTROL NETWORK AT SETTING $\omega_0 = 1/CR$

attenuation/frequency ratios for the frequency control network used. At the zero phase-shift point, i.e. when $\omega_0 = 1/CR$, the voltage attenuation is 9.6 db.; hence a steady-state oscillation is reached when the R.M.S. value of the signal is such that the voltage attenuation at the thermal control NL is equal to 16 - 9.6 db., namely, 6.4 db. The relationship between the voltage attenuation and the R.M.S. current for the type of control employed is shown in Fig. 4.

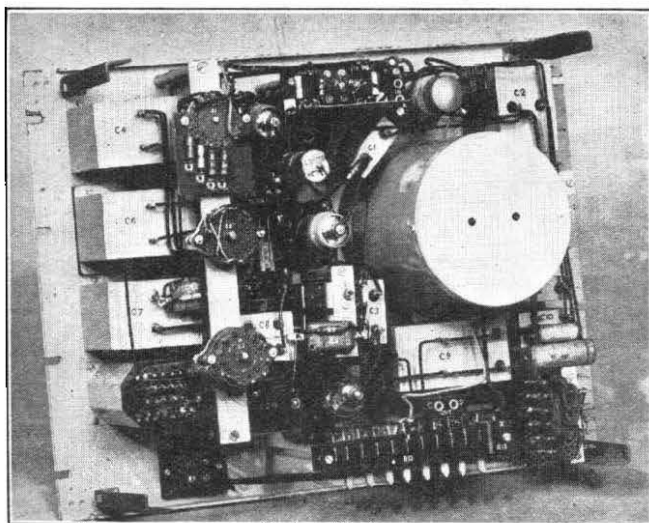
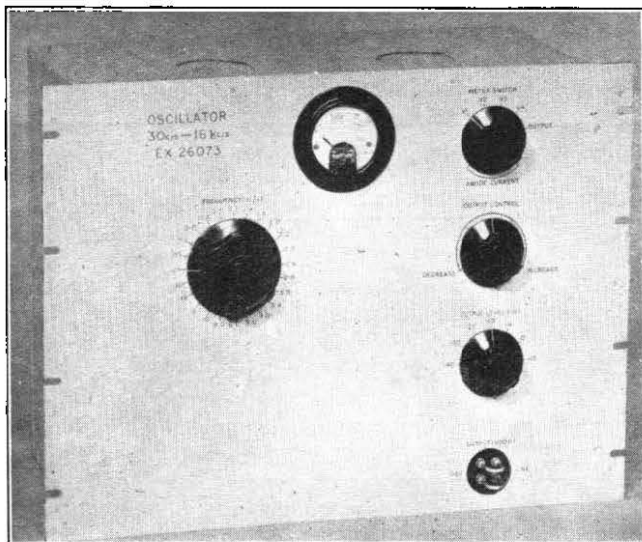

FIG. 1.—THE OSCILLATOR No. 22 SHOWING FRONT OF UNIT AND REAR VIEW WITH COVER REMOVED.

† Senior Experimental Officer, Research Station.

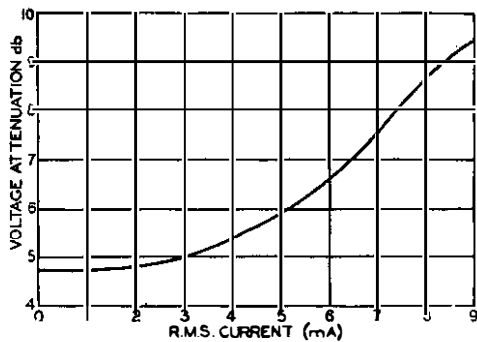

FIG. 4.—ATTENUATION/CURRENT CHARACTERISTIC OF AMPLITUDE CONTROL.

As the amplitude control does not vary with the instantaneous signal values, it has no influence on the waveform, which is determined entirely by the non-linearity of the amplifier characteristic modified by the effective feedback at the harmonic frequency concerned.

The output is taken from the anode of V3, which has a constant-current characteristic, and the screen grid of this valve is decoupled to cathode to ensure that the anode current is identical with the cathode current. The anode load impedance is kept small compared with the anode resistance of V3 to ensure that variations of output load will not appreciably affect conditions in the oscillatory circuit, and result in changes of amplitude and frequency of the generated signal.

CIRCUIT DESCRIPTION

A simplified schematic circuit is shown in Fig. 5 and for ease of description this can be separated into the following major items:—

- The frequency control unit (N3)
- The driving amplifier (V1 to V3)
- The amplitude control circuit (Resistor, Bulb No. 13, R12 and R13)
- The output circuit (N1, N4 and S2)
- The meter stage (V4, etc.).

The Frequency Control Unit.

This unit is constructed around a 24-way wafer switch (Switch, Frequency, No. 3), and enables the frequencies, shown in Table 1, to be selected, with a tolerance of ± 1 per cent. or 1 c/s, whichever is the greater.

TABLE 1

Frequency	Switch setting	Frequency	Switch setting
30 c/s	4	2.8 kc/s	16
50	5	3.0	17
100	6	3.4	18
200	7	4	19
300	8	5	20
500	9	6	21
800	10	7	22
1.0 kc/s	11	8	23
1.6	12	10	24
2.0	13	12	1
2.4	14	14	2
2.6	15	16	3

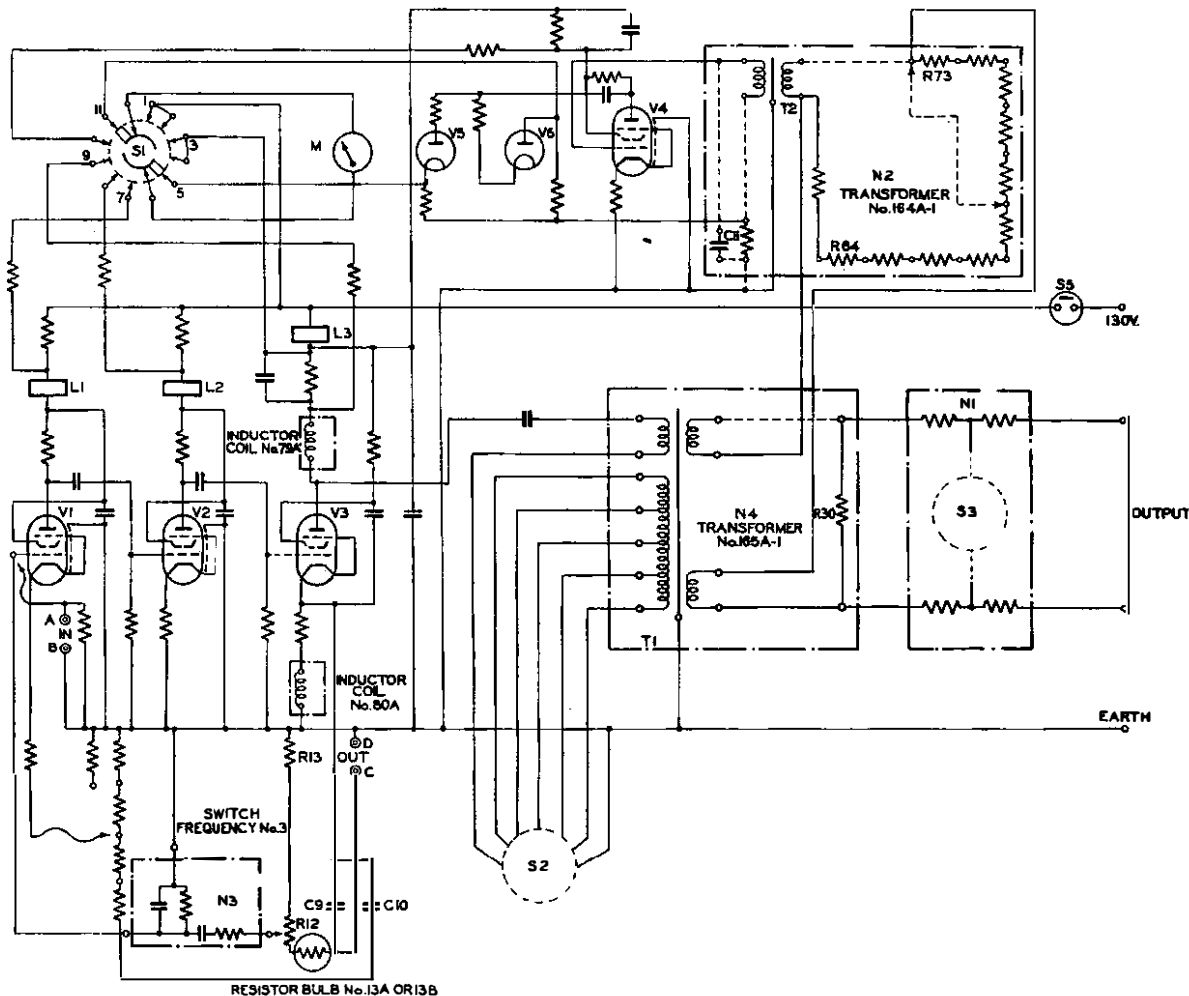

FIG. 5.—SIMPLIFIED CIRCUIT DIAGRAM OF OSCILLATOR NO. 22.

Changes of resistance are made at decade intervals, namely 300 c/s and 3 kc/s, and individual frequency changes are accomplished by altering capacitance values, common capacitors being used wherever possible. The switch incorporates a trimmer capacitor to neutralise the amplifier input capacitance, while other capacitor combinations are used to cancel positive reactances associated with the precision resistors, and to adjust the frequency and level response of the respective ranges. The components of this unit are housed in a cylindrical copper screening can, the

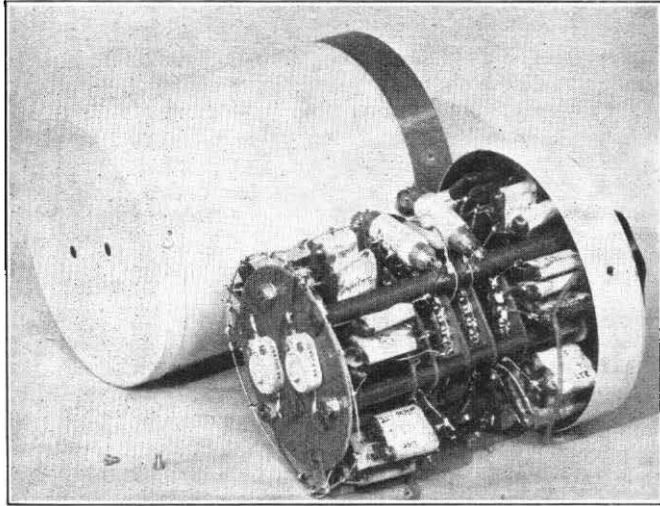

FIG. 6.—FREQUENCY CONTROL UNIT REMOVED FROM SCREENING CAN.

prototype of which is shown in Fig. 6; the whole assembly can be removed from the body of the oscillator in the event of a fault developing in the network. The position of this unit in relation to the other components can be seen in Fig. 1.

The Driving Amplifier.

The amplifier, comprising stages V1 to V3, is designed to have a voltage gain of 16 db. between the grid of V1 and the test points C and D at the cathode of V3, with substantially zero phase-shift in the frequency range 30 c/s to 16 kc/s. Fig. 7 shows the gain/frequency characteristics

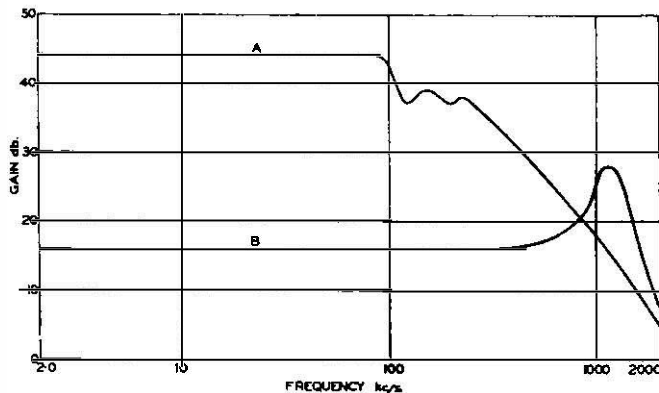

FIG. 7.—GAIN/FREQUENCY CHARACTERISTIC ABOVE 2 kc/s
A. WITHOUT NEGATIVE FEEDBACK.
B. WITH NEGATIVE FEEDBACK.

above 2 kc/s with and without negative feedback, from which it can be seen that the maximum gain reduction due to feedback is about 28 db. Below 2 kc/s the gain falls and is 3 db. less at 30 c/s. The ripples in the response without feedback in the region of 100 kc/s are due to output transformer resonances, while the excess of gain with feedback

over that without feedback in the region of 1.1 Mc/s gives a measure of the stability margin at this end of the frequency scale.

Below 2 kc/s the response with feedback continues to be constant until a point well below 30 c/s is reached. The stability margin at this end of the frequency scale is adequate, the loop phase-shift not exceeding 80° when the loop gain becomes unity, i.e. in the region of 2 c/s.

The provision of separate capacitors, C9 and C10, in the positive and negative feedback paths permits of phase compensation in the region of 30 c/s. To reduce the stray earth capacitances, which affect the stability margin at the high-frequency end, a number of the coupling capacitors have their cases insulated from the mounting plate.

Retard coils are used instead of resistors for decoupling purposes because of the restricted anode supply voltage, namely 130V.

The Amplitude Control Circuit.

This consists of the Resistor, Bulb No. 13A or 13B and the resistors R12 and 13, which together form a network having a voltage attenuation dependent on the R.M.S. value of the current supplied to it, as shown in Fig. 4. R12 is a tapped resistor and provides for attenuation adjustments over a limited range during normal operation. Resistors, Bulb No. 13A or 13B consist respectively of eight or nine Lamps No. 2, 6V, with tungsten filaments, mounted on a paxolin strip, and have a total resistance of 186 ohms ± 5 per cent. with an R.M.S. current of 5.8 mA at an ambient temperature of 17°C . Individual lamps are tested prior to mounting and conform to the requirements of the following specification:—

- (1) Resistance at 17°C ambient temperature and with a current of 5.8 mA R.M.S. to be not less than 23 ohms for a maximum of eight lamps, or 21 ohms for a maximum of nine lamps. The total resistance of the lamp strip to be 186 ohms ± 5 per cent. for the above conditions.
- (2) Sensitivity, i.e. change of resistance with current, to be not less than 12 per cent. for a current change from 5.6 mA R.M.S.
- (3) Time-constant measured in a high-impedance bridge circuit to be between 1 and $2\frac{1}{2}$ sec. with a current change from 5.6 mA R.M.S.

The theory underlying the lamp specification has been explained in a previous article.¹

The Output Circuit.

A constant current output is derived from the anode of V3 in the driving amplifier, and fed via transformer N4 into the load resistor R30. From this point the output circuit has an impedance of 600 ohms balanced to earth. Fine control of output level is achieved by means of tappings on N4 selected by wafer switch S2, and permits the adjustment of the current in R30 in eight steps of approximately 0.25 db. each. Coarse control is provided by the balanced bridged-T attenuator N1 which gives five steps of 10 db., selected by switch S3, with an accuracy at each step of ± 0.25 db.

The return loss relative to 600 ohms measured at the output of the oscillator is not less than 20 db. at 30 c/s and 60 c/s, and greater than 30 db. at all other frequencies with the output control switch S3 at the +10 db. position. At all other level positions the return loss is greater than 40 db. at all frequencies. A further merit of having the level control situated in the output circuit is that the harmonic content of the signal is independent of the setting of this control.

¹ "Temperature Dependent Resistors." Cooper, W. H. B., and Seymour, R. A. *Wireless Engineer*, Vol. 24, p. 298.

The Meter Stage.

The meter performs two functions, the necessary connection changes being performed by switch S1.

- (1) In association with resistors it indicates the total D.C. flowing in each of the four valves V1 to V4 and for this purpose the meter scale has a red area covering a range of ± 25 per cent. on a mean deflection of 0.4 of full scale.
- (2) In conjunction with V4 and the diodes V5 and 6, it measures the A.C. supplied to the output circuit of the oscillator. For this purpose the meter scale is calibrated at 1 db. either side of a mean deflection of 0.8 of full scale.

To preserve the earth balance of the output circuit, the input transformer T2 to the meter stage is connected in the centre point of the output winding of N4. Resistors R64 to R73 are provided for calibration purposes. V4 is introduced between T2 and the diode rectifiers V5 and V6 to prevent distortion of the output signal owing to the non-linear operation of the rectifiers. In addition, this amplifier stage provides a high-impedance circuit for the rectifiers, which, together with negative feedback of 6 db. in series with T2, makes the rectified meter current substantially independent of changes in the rectifier characteristics. V4 is further stabilised by means of the un-decoupled cathode resistor, which gives approximately 12 db. of negative feedback. C11 is provided to suppress local oscillations which can otherwise occur outside the normal operating frequency range.

PERFORMANCE DATA

The following information is based on measurements carried out on a number of oscillators constructed for field trial purposes.

Frequency Stability.

The frequency stability, (a) with battery variations, is of the order of ± 4 parts in 10^6 per 1 per cent. change of heater supply and -4 parts in 10^6 per 1 per cent. change of anode supply; and (b) with temperature, is of the order of 100 parts in 10^6 per 1°C on ranges for frequencies 300 c/s to 16 kc/s, and 400 parts in 10^6 per 1°C for frequencies 30 c/s to 200 c/s.

The initial accuracy of frequency is ± 1 per cent. or 1 c/s, whichever is the greater. The maximum change of frequency due to a reactive load applied to the output circuit does not exceed 1 part in 10^4 .

Output Level.

Variations of output level with battery supply and temperature changes are respectively:—

- (a) $+0.02$ db. per 1 per cent. increase of anode or heater supply.
- (b) -0.02 db. per 1°C increase at 20°C .

As initially set up, the variations of output level with frequency do not exceed ± 0.2 db.

Book Review

“Verstärker und Empfänger (Amplifiers and Receivers). Revised Edition 1951. M. J. O. Strutt. Springer-Verlag, Berlin—in German. 422 pp., 425 ill.

This book is intended primarily for the radio designer, although it contains much information which is of general interest to the communications engineer. It is not merely a design handbook, but each aspect of the design of a modern radio receiver is carefully dealt with from the theoretical point of view and then demonstrated by practical circuits and photographs showing details of construction. The latter have not been brought up to date since the original edition, but the author hopes that new illustrations will be included in a future edition.

Harmonic Production and Noise Level.

The signal-to-harmonic ratio of the second harmonic is greater than 40 db. and that of the third harmonic is greater than 50 db., independent of the fundamental frequency. With the type of output level control used, these ratios are relevant to all levels of output.

The only noise of consequence present at the output of the oscillator is that emanating from the battery supplies, in which these are float-charged from rectifiers the main noise is hum at 50 c/s and harmonics thereof. As an example 30 mV of 50 c/s in the anode supply gives a signal-to-noise ratio at the oscillator output not less than 60 db. In this condition, if the frequency selector switch is set to 50 c/s, the output will be amplitude-modulated at the difference frequency to a depth not exceeding 1 per cent.

If the heaters are operated from a 50-c/s supply, the level of the 50 c/s and 100 c/s interference at the oscillator output has a signal-to-noise ratio not less than 60 db., while, at the 50 c/s setting of the frequency control, amplitude modulation does not exceed 1 per cent.

Meter Circuit.

When connected to measure the D.C. in the valves, the meter reading can have a maximum error of ± 8 per cent. due to resistor tolerances, which will be fixed for each valve.

In measuring the output level the accuracy with frequency changes is 0.15 db., except at 30 c/s where the error is from $+0.1$ to $+0.3$ db. This increase at 30 c/s is due to coupling with the oscillator output stage via the 80-ohm retard coil. The variations in reading with changes in battery voltage are 0.01 db. per 1 per cent. change of heater or anode supply voltage, and are independent of frequency.

Intermittent Behaviour at Low Frequencies.

It was noted, mainly at frequencies below 100 c/s, that the output does not settle down to a normal steady value immediately after the frequency selector switch is positioned at a setting, i.e. the output signal is modulated in amplitude by a damped oscillation having a frequency of a few cycles per sec. A mathematical explanation of this effect is given in the article previously referred to.

In order to shorten the duration of the transient, and to avoid locking-up of the amplifier due to charging of the inter-valve coupling capacitors, the second stage of the amplifier is given additional negative bias, so that limiting occurs when the signal level rises about 3 db. above normal.

CONCLUSION

This oscillator will become the standard repeater static audio-frequency oscillator, and specifications have been published covering the details and performance of the oscillator and its component parts.

The latest version of the oscillator is the Oscillator N 22C, which has the frequencies quoted above. Earlier versions (22A and B) had different frequencies.

Contracts have been placed for 200 Oscillators No. 22 and it is hoped that the first of these will be delivered within a few months.

Some idea of the scope of the work can be gained from the fact that the fundamental theory covered includes, for example, integration in the complex plane and its application to stability criteria for feedback amplifiers, Fourier integrals, the theory of linear quadripoles, etc. Theoretical and practical details are given of various types of components, including resistors, inductors, capacitors and multi-electrode valve together with circuit design data covering a wide range of radio receiving equipment for amplitude, frequency and pulse modulation signals.

It is unfortunate that no English translation is yet available since, apart from the language difficulty, this can be recommended as an extremely useful reference book.

V. G. W.

The Fault Recorder or Docket Printing Machine

T. F. A. URBEN, B.Sc.(Eng.), A.M.I.E.E.†

U.D.C. 621.395.365: 53.087.4

The equipment described in this article has been designed to record, automatically, faults which are found when automatic exchange equipment is under test by routiners. The records are in the form of dockets on which full details, e.g., location, description, day and time, are printed. The "Fault Recorder No. 1," as the equipment is known, will work in conjunction with the new-type routiners now on field trial, and with the earlier types.

Introduction.

ALTHOUGH automatic routine testing equipment has been in existence since the early days of automatic telephony in this country,¹ such equipment has not been entirely automatic; it has always required staff in attendance to record details of any faults found even when it may not be convenient to deal with such faults immediately.

Concurrently with the development of the new automatic routiner, described in a recent article,² an equipment was designed to record the details of any faults found by the routiner. By the use of this equipment, the routiner is rendered completely automatic in that, as well as the automatic commencement and cessation of testing being preset for any required time, details of equipment found faulty may be recorded and the routiner may then proceed to test the next equipment in sequence without the need for any attention. It is now possible, therefore, for these new routiners, when associated with this recording equipment, to test the main equipment at a time which will cause least interference with traffic, even though there may be no staff on duty at that time.

It is also possible for existing routiners to be modified to work to the recording equipment. In exchanges where this is done, maintenance staff, when engaged on other work, will no longer suffer the interruption caused by the necessity to record details of faults found by the routiner. Such faults can be distributed under control in the same manner as are non-routine faults.

This article describes this fault recording equipment which is now known as the "Fault Recorder No. 1." At one time, as indicated in the article on the New Type Routiners, it was termed the Docket Printing Machine.

The facilities provided by the equipment are as follows:—

- (a) To print,
 - (i) the title of the routiner to which it is connected,
 - (ii) the location of the equipment proved faulty,
 - (iii) the description of the fault,
 - (iv) day and time of the fault,
 - (v) serial number of the fault docket.
- (b) To print the information in the appropriate spaces on a docket form.
- (c) To provide a duplicate copy of the printed information.
- (d) To give an alarm condition when the supply of paper is exhausted.
- (e) To be capable of association with any routiner.

Facilities (a), (b) and (e) are provided in conjunction with the Routiner Fault Translation and Docketing Machine Control Circuit, which is briefly described at the end of this article, in so far as it controls the recorder.

General Description.

The recorder, with covers removed, is shown in Fig. 1. It consists of three assemblies associated to form a unit which is then jacked into a framework mounted on a M.A.R. or other convenient rack. The framework has been coded separately as a "Cradle No. 1." Electrical connections between the cradle and the fault recorder are made via two 32-point shelf plugs and jacks.

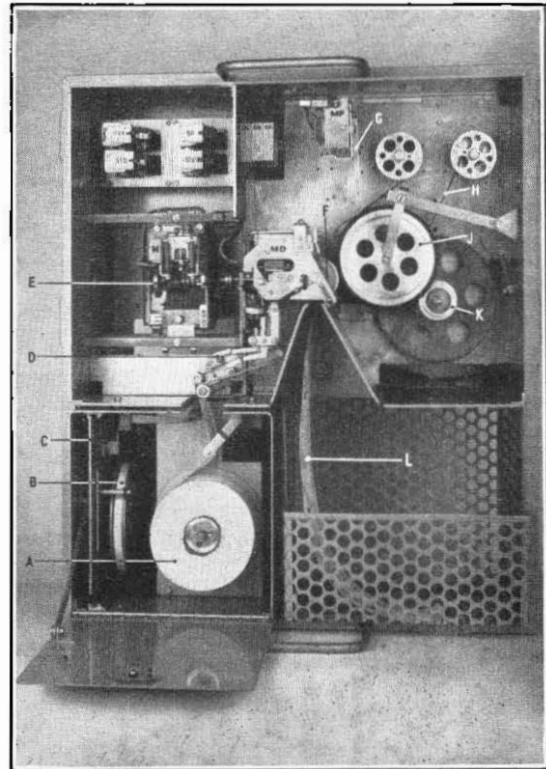

- A. Docket Paper.
- B. Duplicate Tape.
- C. Magazine.
- D. Paper Fail Detectors.
- E. Character Selection.
- F. Paper Feed Drive and Platen.
- G. Printer Hammer Magnet.
- H. Type Ribbon.
- J. Slipping Drive to Take-up Spool.
- K. Duplicate Tape Take-up Spool.
- L. Completed Dockets.

FIG. 1.—THE RECORDER WITH COVERS REMOVED.

The top assembly contains the operating mechanism, consisting of:—

- (a) Paper feed drive and printing platen.
- (b) Character selector and typehead.
- (c) Printer hammer.
- (d) Paper fail detection contacts.
- (e) Duplicate tape take-up spool and slipping drive.
- (f) Type ribbon and ribbon drive reversing mechanism.
- (g) Relays, spark quenches, etc.

The lower-left assembly contains the magazines for the roll of dockets and the duplicate copy tape, the latter being on a sliding platform which may be drawn forward to facilitate reloading the copy tape spool. The lower-right assembly consists of an open perforated metal trough into which the printed dockets are discharged.

† Senior Executive Engineer, Telephone Development and Maintenance Branch, E.-in-C.'s Office.

¹ P.O.E.E.J., Vol. 22, p. 24; Vol. 26.

² P.O.E.E.J., Vol. 44, p. 147.

Outline of Operation.

A routiner, having detected a fault, is connected to the fault recorder by the routiner fault translation and docket machine control equipment. This equipment arranges that signals detailing the characters to be printed are fed, one at a time, to the fault recorder where a docket will be in position on the printing platen for the first character to be printed. The typehead is rotated to the correct position for the first character which is then printed and the platen stepped to move the docket ready for the next character. This process is repeated until all characters are printed, when the docket is automatically moved on, allowing the next docket to be in position, and a signal indicating completion of the docket is transmitted to the routiner.

Dockets and Duplicate Tape.

The dockets for use with the recorder have been designed to enable the automatic printing to be made in a continuous line. A typical docket is shown in Fig. 2, in which it will be

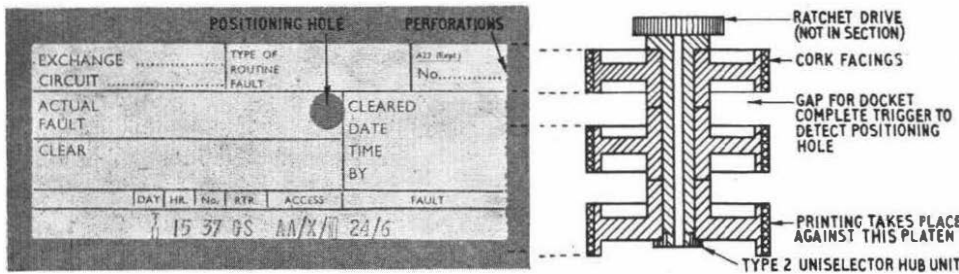

FIG. 2.—COMPLETED DOCKET AND PLATEN IN SECTION.

seen that a hole is pre-punched in the docket; this hole provides a control to enable the docket to be positioned prior to printing, thus ensuring the characters are printed in the correct spaces. The dockets are supplied in rolls of 10,000 and may be separated by tearing along the perforated dividing line.

A duplicate copy of the recorded printing is supplied for statistical purposes, if required, in the form of a 3/8-in. wide paper tape. This is carbon backed and, during the printing process, is laid on top of the docket; thus the characters are printed direct on to the tape, while the docket is, in fact, a carbon copy. By this design, when the duplicate tape is not required there is no wastage of carbon backing, as there

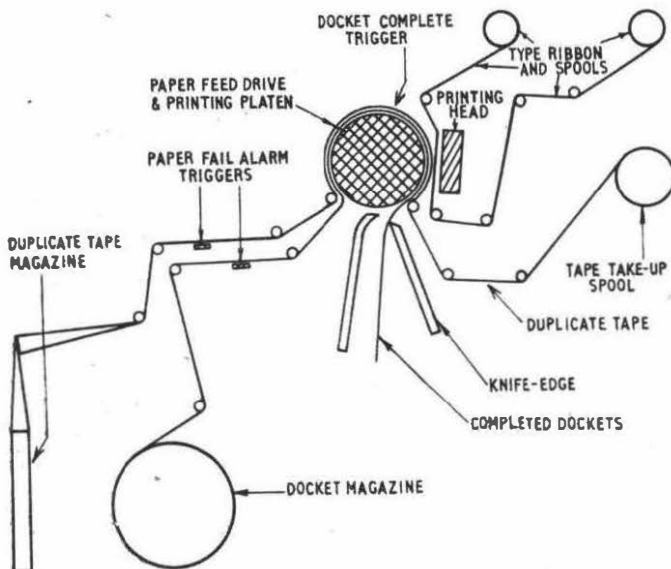

FIG. 3.—PATH OF PAPER THROUGH RECORDER.

would be were the docket to contain the carbon backing for printing through to the tape. It will also be appreciated that the paper feeding arrangements are simplified in arranging that the narrow tape runs round the printing platen on top of the wider docket rather than underneath.

Paper Feed and Drive Mechanism.

A schematic diagram of the path of the dockets and tape through the recorder mechanism is shown in Fig. 3.

To economise in space and to facilitate recharging the magazines, the tape supply roll is positioned at right-angles to the docket roll and suitable rollers guide the tape to a position parallel to the docket path. The tape and dockets are then led in parallel paths, but sufficiently displaced to enable the "paper fail" detector triggers to check the presence of each, after which they are brought together and laid round the printing platen. This platen also moves the tape and docket as required under the control of a ratchet mechanism.

The platen (see Fig. 2) consists of a cork-faced drum formed in three sections, partly for lightness in construction but also providing, in this way, a gap into which the "docket complete" trigger may move on locating the positioning hole in the docket. As the drum is positioned in Fig. 2, it is the lower section against which the printing action takes place, just before the dockets leave the platen. Views of the platen and printing mechanism are shown in Figs. 4 and 5.

The Type 2 unselector mechanism forms the basis of the driving unit, the platen being mounted on the normal ratchet and hub unit. The framework is of special design to mount the docket complete trigger and the spring-loaded rollers which maintain the paper in contact with the platen. The magnet and armature mechanism are of standard design, although some slight modification to the armature has been found necessary to increase the power of the return spring since, like the unselector, the mechanism operates by reverse action and the drum is rotated by the springs on the release of the magnet.

The drive is coupled to the take-up spool by a friction pulley which allows for the difference in ratio required as the spool fills up. On later models the "slipping drive" is obtained by spring cord coupling.

On leaving the printing platen the duplicate tape is

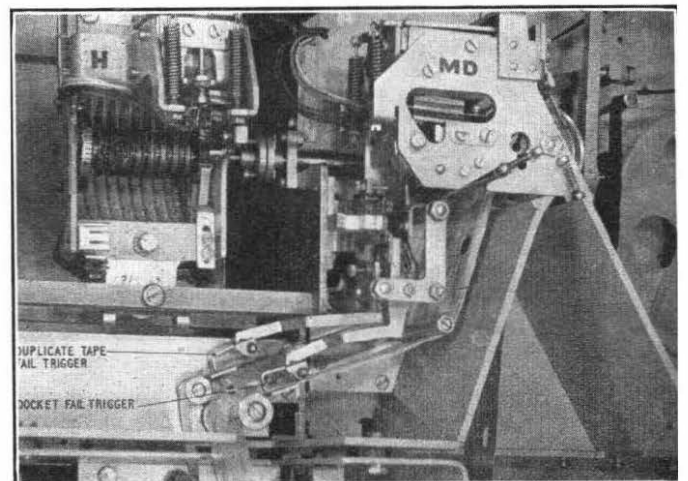

FIG. 4. CHARACTER HUNTER, PLATEN DRIVE AND PAPER FAIL MECHANISM

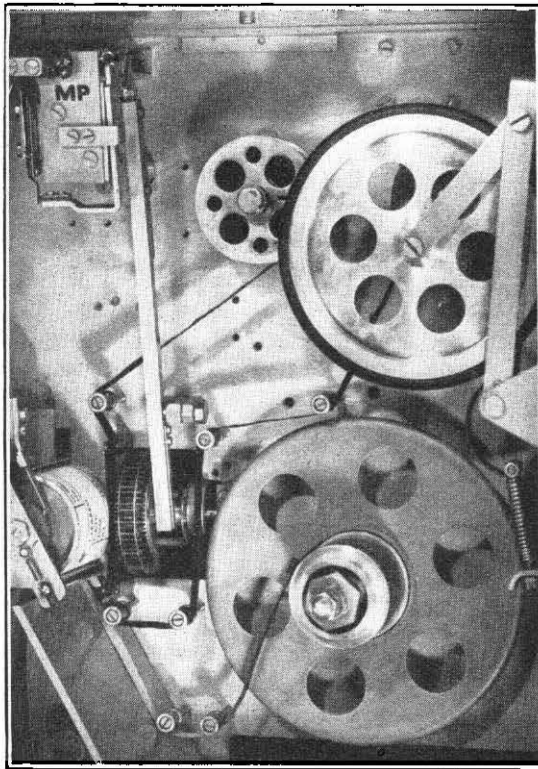

FIG. 5.—DOCKET AT THE PRINTING POSITION.

wound on to a take-up spool, while the dockets are fed through the discharge guide plates into the tray. These discharge guide plates are specially shaped, the right one having a knife edge against which the separating perforations of the docket bear after printing; thus the completed docket may be easily torn off by pulling against the knife edge. The left plate guides the end of the docket off the platen so preventing it from curling round the platen into the printing positions again and thus jamming the mechanism.

Character Selections.

A teleprinter typehead with certain additional characters is used for printing and is mounted on the extended shaft of a Type 2 uniselector, having the bank and ratchet wheel modified to provide 64 positions to match the 64 type spaces on the typehead. The following characters are provided on the typehead:—

Letters	A-Z
Numerals	2-9
Composites	B/W I/C O/G TU TH SA SU 10
Signs	* / -

The composite characters are provided to permit each of the numerals 1 to 10, the day of the week, or B/W, etc., to be printed at one operation.

Each required character is presented in the printing position by rotation of the uniselector (and typehead) until a marked contact on the hunter bank is seized. The positioned character is then struck by the printer hammer to imprint the character on the docket.

The printer hammer is formed as an extension to the armature of a Type 2 uniselector magnet mechanism and is illustrated in Fig. 5, where also the path of the type ribbon is shown. The reduction and reversing gearing for moving the type ribbon is mounted behind the baseplate and is driven by another uniselector magnet and ratchet mechanism.

Paper Fail and Positioning Contacts.

It is a requirement of the new type of routiner that any failure occurring on the routiner or its associated apparatus shall cause an alarm to be given and shall immediately cease the routine testing; by this means incorrect test results are avoided. Thus it is essential that any failure of the paper supplies in the fault recorder shall be indicated and that, at the same time, routiners shall be prevented from seizing the recorder. This facility is provided by the triggers shown in Fig. 3, which check the presence of supplies of dockets and duplicate tape; an exploded sketch of the docket fail trigger and coupling levers is shown in Fig. 6.

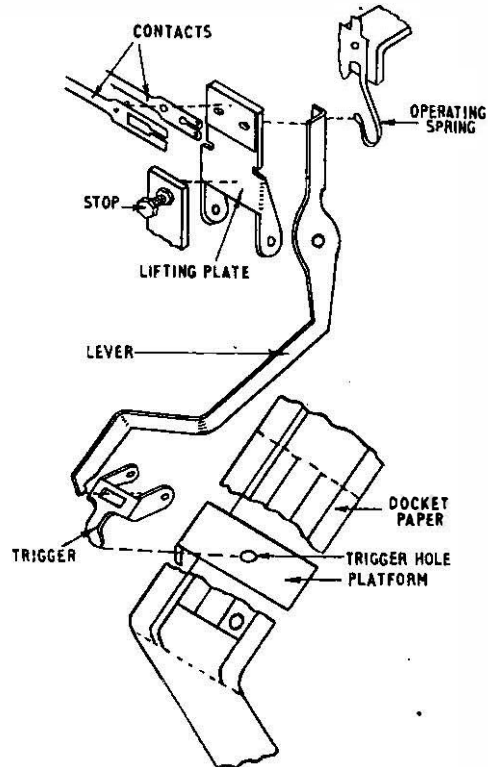

FIG. 6.—DOCKET FAIL ALARM MECHANISM—EXPLODED VIEW.

The trigger tip bears on the paper above a hole in the backing plate and, while the paper is present, is prevented from dropping into the hole. In this normal position, the trigger supports the end of a lever which has its tip resting upon the surface of the trigger at the rear end. When the supply of paper fails, the trigger tip drops into the hole and the tip of the lever rides off the end of the trigger. The lever then drops under the action of the operating spring, thus moving the lifting plate against the stop. The lifting plate, in moving, operates contacts, which are normally made, thus disconnecting the "docket complete" lead (see Fig. 7). The levers for both the docket fail and the tape fail trigger bear against the same lifting plate; thus the contacts are operated if either paper supply fails. These contacts provide an alarm indirectly since, in the absence of an earth on the docket complete lead, the next routiner to find a routine fault will be unable to seize the recorder and will then cause an alarm to be given. The presence of this earth, however, is only checked by the control circuit prior to commencing a docket; the contacts are so positioned, therefore, that, should they operate during printing, there is sufficient paper in the run for that docket to be completed.

Each trigger has a small rectangular hole in its upper surface. When the trigger is lifted by hand the lever tip will drop into this hole, locking the trigger in position away from the paper. This action is provided to hold the triggers

clear during replacement of paper supplies so that the tape and docket may easily be fed by hand through the guide rollers on to the platen.

Circuit Operation.

Fig. 7 shows the circuit diagram of the recorder, which is connected, as indicated, to the docketing machine control circuit.

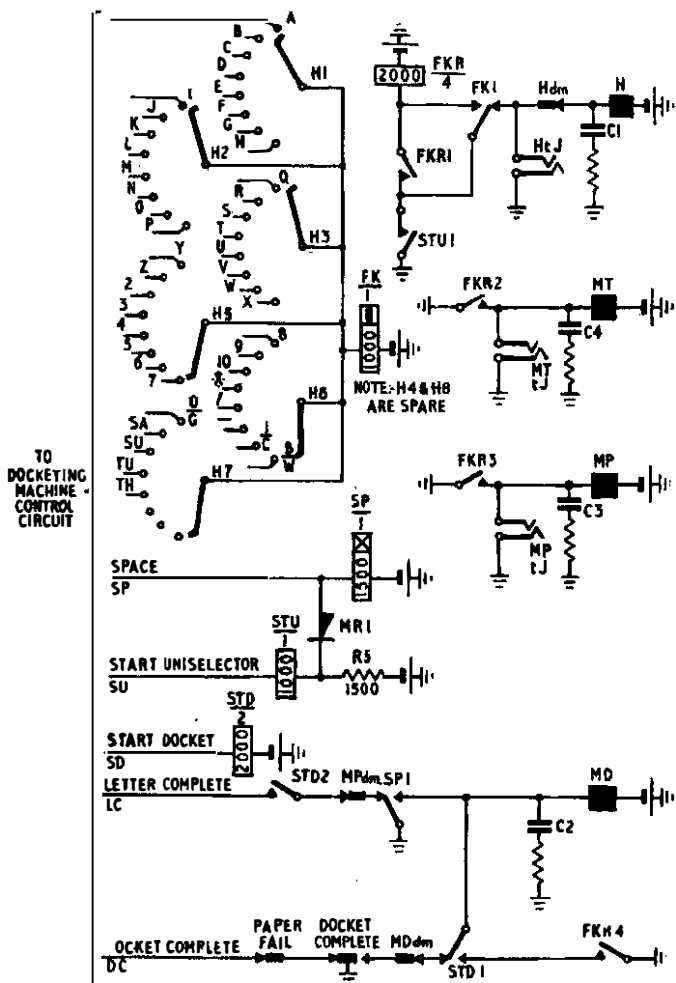

FIG. 7.—CIRCUIT OF RECORDER.

The docketing machine control circuit (described in a subsequent paragraph) first checks that the recorder is ready for printing by detecting the earth on the "docket complete" lead; the recorder is then seized by the operation of relay STD which, at STD2, extends a check earth on the "letter complete" lead. The marking for the first character is then received and at the same time relay STU is operated, causing the hunter to search for the marked character. On finding this, relay FK operates, stopping the hunter, which has now positioned the typehead ready for printing, and operating relay FKR. Relay FKR energises the platen drive magnet MD and the printing magnet MP, causing the hammer to print the character. The contacts MPdm of the printer magnet disconnect the "letter complete" earth, indicating that the next character should be marked. This causes the new marking to be set up and relay STU to be released, thus releasing FK and FKR. The release of FKR restores the printer and releases MD, thus allowing the platen to step and to position the docket ready for the next character.

The release of contacts MPdm allows relay STU to be re-operated. This sequence of operations is then repeated for each character in turn. In addition, each operation of relay FKR causes the type ribbon drive magnet, MT, to step the ribbon, thus ensuring a good ink supply.

When all the characters required have been printed, the control circuit releases relay STD. When the docket was stepped forward during printing, the "docket complete" trigger was raised out of the hole in the docket, and the "docket complete" contacts were operated. The release of STD1 thus provides a path for the self-drive of the platen until the next docket is in the appropriate position, for the release of the "docket complete" contacts. The number of characters printed on the docket is restricted to provide several steps of self-drive before these contacts can be operated again.

Should a "space" be required between the characters, the operation of the printer hammer is avoided by the use of relay SP. On the receipt of a space marking SP operates, while STU is released via the shunting rectifier. Thus the rotation of the hunter is stopped while the platen drive magnet is operated directly.

Routiner Fault Translation and Docketing Machine Control Circuit.

The connections between this circuit and the recorder are shown in simplified schematic form in Fig. 8.

In brief, its operation is such that, when a routiner has proved a faulty condition, the routiner relay AL operates, seizing the control circuit relay ST and marking the arc RH1.

Providing the fault recorder "docket complete" signal is present, ST1 causes the routiner hunter, RH, to search for the calling routiner. If the "docket complete" signal is not present, the routiner hunter cannot operate and thus further action is held up until the Recorder is ready; if this delay is prolonged, an alarm supervisory condition will be brought up indicating the cause of the delay (e.g., paper fail).

When the routiner hunter detects the calling routiner, relay RHA operates, thus operating PS and hence seizing the recorder by operating STD. This causes the check earth to be extended on the LC lead to operate SA and SB.

The recorder then prints the first character, as described above, which is marked via MD and DN arcs. This will be the Day character—M, TU, W, TH, etc., the arcs of uniselector DN being cross-connected as required to the appropriate character on arc H. At the completion of printing, MPdm operates, releasing SA and thus SB. During the release period of SB (which is slow to release) the magnet of MD is pulsed and MD steps to the next position, marking a space (relay SP) into the recorder. This process of marking interaction of MPdm, SA, SB and MD, continues for each outlet of the marker distributor MD; by this means the marking earth is connected to the appropriate character on arc H by arcs of, in turn, the Day DN, Time T and Serial No. SN uniselectors. The code of the routiner connected to the recorder is next marked via arc RH4, while the access details of position of the faulty equipment are recorded via suitable arcs on the access switches and distributor switches. Lastly, details of the fault are marked via the test uniselector or suitable contacts in the routiner.

After the MD switch has connected the last required marking into the recorder, it steps to contact 24, thus releasing relay PS which, once the "docket complete" signal had been removed by the movement of the docket paper, was held to the earth on the arc MD4.

The release of PS releases the recorder, causing the docket to be driven through and the "docket complete" earth signal to be reapplied to arc MD4 and hence to be

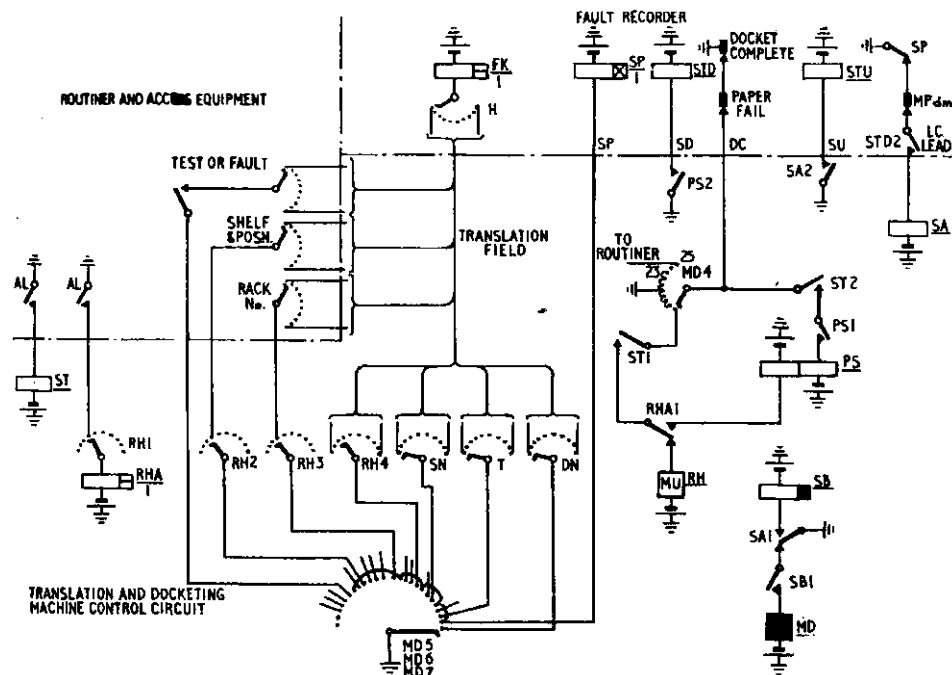

FIG. 8.—CONNECTIONS BETWEEN ROUTINER, CONTROL CIRCUIT AND RECORDER.

transmitted to the routiner. The routiner then releases ST and RHA, and thus frees the docketing control circuit for further duty.

It should be noted that in Fig. 8, for simplicity, only one path has been indicated for each of the group markings, although there are, in fact, as many marking and translation paths as there are characters in a completed docket. The printing on a completed docket is shown in Fig. 2. This was recorded on Tuesday at 3 p.m. (15) Serial No. 37 for a group selector routiner. The faulty equipment was on Rack AA, Shelf X, position 10, the fault code being 24/6.

Mechanisation centres and further models are now being built for this purpose and for use with the new-type group selector routiner at Hayes.

Acknowledgments.

The assistance given by many members of the Subscribers Apparatus Branch, Telephone Branch and the Factories Department in the development of this equipment is gratefully acknowledged; in the preparation of this paper, the author is particularly indebted to his colleagues in Telephone Branch.

Performance.

One model of the fault recorder has been built by the Factories Department and, after exhaustive tests in the Telephone Branch Circuit Laboratory, has been installed at Holborn Tandem Exchange; five existing group selector routiners were modified to work, via a special translator and control circuit, to the recorder. This has now been in service for a considerable period and, apart from the assistance given the staff by freeing them from the need to attend to the routiner and record the faults, the recorder has enabled many intermittent faults to be discovered and cleared; the facility with which these faults are recorded every time they occur has provided ready data for a rapid analysis of the causes of the faults.

While the recorder has not been in operation long enough to permit a firm policy as to its future provision to be evolved, the recorder is to be installed in the Trunk

Book Review

"Sound Recording and Reproduction." J. W. Godfrey and S. W. Amos, B.Sc., A.M.I.E.E. B.B.C. Engineering Training Dept. Iliffe & Sons. 271 pp., 186 ill. 30s.

This volume has been written primarily as an instruction manual for the use of engineering staff of the B.B.C., and a considerable part of the book is devoted to detailed descriptions of the particular recording equipments in current use by the Corporation. In addition to the B.B.C.'s own design of disc recorder, details are given of the American Presto disc recorder and an early model of the M.S.S. disc recorder; the Phillips-Miller film equipment and the Marconi-Stille, Magnetophon and E.M.I. magnetic tape systems are also described. These chapters make interesting reading, although as a review of contemporary recording equipment the list is far from complete.

The remainder of the book is of more general interest. The opening chapters introduce the reader, in an admirably lucid and straightforward manner, to the general principles of sound-recording and reproduction and, in particular, of disc recording. Magnetic tape and sound film recording are also dealt with, but in much less detail. Chapters dealing with the reproduction of disc recordings will be of special interest to gramophone users who are interested in high quality. The characteristics of various types of pick-up are discussed, and the equalisation for a popular light-weight pick-up given in detail.

Throughout the book the authors have maintained an attractive and readable style, yet in spite of the necessity for compression the book is commendably free from errors resulting from over-simplification or generalisation. It is perhaps a pity that so much emphasis is laid on frequency response as the criterion of performance, and that so little space is devoted to non-linearity and intermodulation—presumably because of a desire to avoid mathematical treatments in the text. The section on pick-up resonances may be somewhat misleading (again, largely because of the avoidance of mathematical analysis) in implying that the peak usually found at the upper end of the frequency response is a function of armature suspension stiffness, whereas in fact this is usually negligible compared with the stiffness of the needle. The argument (page 52) that a rising recording characteristic increases the stringency of the intermodulation requirements in the recording-reproducing process is also unconvincing.

However, these are very minor blemishes in an otherwise well written and very comprehensive work, and no doubt arise because of the authors' desire to present as complete a picture as possible in a readily assimilable form to the reader who is comparatively new to sound recording problems. In this aim they have succeeded most creditably.

F. E. W.

C.C.I.F. Field Trials of International Semi-Automatic Telephone Operation

J. V. MILES†

Part 1.—Signalling and Switching Principles

U.D.C. 621.395.35:621.395.5

This article gives a broad outline of the problems involved in providing a semi-automatic international telephone service and describes the solutions proposed by the International Telephone Consultative Committee (C.C.I.F.). Part 1 deals generally with the basis of the design of two proposed international signalling systems (1 V.F. and 2 V.F.) with which experience is to be obtained during field trials due to commence later this year. Part 2 will discuss the principal facilities to be afforded and indicate briefly how these are being provided, with particular reference to the London equipment.

Introduction.

ALL international telephone circuits linking Great Britain with Europe are at present operated on a manually switched basis using generator signalling, and this method of working, involving at least two international operators on every call and giving restricted signalling facilities, limits the efficiency with which the circuits can be operated. With the increasing volume of international traffic, Administrations are faced with difficulties due to the overloading of manual switchboards and in the recruitment of operators possessing suitable qualifications in foreign languages. The provision of improved signalling facilities on the present manual basis would undoubtedly increase the efficiency with which international circuits could be exploited; but bearing in mind the progress of the mechanisation of inland trunk switching on the Continent in recent years and the potential benefits of semi-automatic operation if applied to international calls, Administrations would not be inclined to incur a large capital expenditure solely on improving the signalling facilities on the manual circuits, especially with the knowledge that this method of working may soon become obsolete. The proportion of traffic which can be completed by an outgoing international operator without the intervention of an operator in the incoming country will depend, of course, on the extent to which the various national networks are mechanised; but as the majority of international calls occur between the large European towns, most of which have automatic operation for local calls, it will be possible to dispose of a large percentage of international traffic with semi-automatic operation even though nationwide dialling facilities may not be available. Although the introduction of semi-automatic operation on international circuits involves many problems not normally encountered on the national networks it is generally agreed that, with the use of modern techniques, a reliable and economic semi-automatic service can be provided for international telephone traffic.

Since the cessation of hostilities in 1945 the C.C.I.F. has continued the work, which it began before the war, of resolving the basic principles of a general switching plan for Europe.¹ This task is not yet completed but, having generally agreed the basis of the signalling system, the committee is now determining the composition of the signalling code. Two proposed codes of signals are under consideration, one based on the use of two signalling frequencies and another utilising only one signalling frequency; equipment designed for semi-automatic operation on the basis of each of these proposed codes is to be subjected to field trials which the C.C.I.F. has instituted before making precise recommendations regarding a code of signals for standard adoption.²

† Assistant Engineer, Telephone Development and Maintenance Branch, E.-in-C.'s Office.

¹ "C.C.I.F. General Telephone Switching Programme for Europe (1947-52)." Montreux, 1946.

² C.C.I.F.—CEA. Document No. 12—"General Field Trials Specifications."

Standardisation of Signalling Facilities and Operating Methods.

The advantages to be gained by adopting a standard international signalling and switching system for Europe will be apparent from consideration of the maintenance and operating problems which would arise if the method of working had to be varied according to the country with which communication was required. It must be realised however, that the automatic equipment in the various countries of Europe has developed on independent lines employing different signalling and switching techniques and it has been the task of the various technical and operating commissions of the C.C.I.F. to reconcile the differences and agree upon standard solutions to the problems of inter-working between countries. Typical examples of the technical difficulties encountered are the differences in the speed and "make to break" ratio of impulses used for the transmission of numerical information and the fact that the impulses do not always correspond in number with the digit dialled. Besides differences in numbering, variations occur also in the code lettering of dials on the Continent. These variations can be catered for by omitting letters from the nomenclature of the operators' keysets and this affords a solution for semi-automatic working in which the operators can obtain the necessary translation from visible index files. However, unless a standard association of letters and figures is gradually adopted as national numbering plans are developed, the question will become important in full automatic working and in this respect the C.C.I.F. recommends that Administrations introducing the use of letters in the Latin alphabet should endeavour to adopt the letter-figure combination most generally used in Europe, i.e. as used on the British and French dials.

Basic Factors in the Design of a Standard Signalling and Switching System for Europe.

Voice Frequency Signalling.—It was decided initially that the principle on which the design of the international signalling system should be based would be that of voice frequency signalling on the speech path. Although this method suffers from the disadvantage that precautions have to be taken against the possibility of the imitation of signal by speech currents it was thought that this would be the most economic and practical method to adopt in the circumstances considered.

In arriving at this decision the C.C.I.F. took into consideration the use of signalling systems employing a completely separate signalling channel, but for a number of reasons it was decided not to recommend this principle for international use. It has since been recorded in C.C.I.F. documents that systems which may be described as "associated channel" signalling systems, i.e. systems using signalling frequencies situated between the speech bands of two adjacent telephone channels, were not taken into consideration and that such systems may not, in fact, suffice

the same disadvantages as those that arise with a "separate channel" signalling system, particularly as regards costs. Since, however, the economic advantages of "associated channel" signalling systems depend on the ability of the systems to permit the use of "continuous" signals, simulating directly D.C. signalling conditions, it seems unlikely that such systems could prove more economical than a "signalling on speech path" system on international circuits, where the number of signals to be provided necessitates the use of some form of pulse signalling code. It must be appreciated, also, that an "associated channel" signalling system would not, in general, be immediately applicable on many of the international routes with the existing transmission media.

Coded Digit Signalling System.—As a solution to the general impulsing problem, it was decided that the signals conveying digital information would be transmitted in coded form and that a code based on the principle of binary numbering, and providing a total of 16 available signals, would be used for the purposes of the trials. This method of transmitting numerical information, details of which are described later, has the advantage that the numerical information can be sent very rapidly, the total signalling time is reduced, and signals outside the range 1-0 are available for miscellaneous purposes, such as obtaining access to the various manual board services at the incoming international terminal exchange. The general adoption of a standard digital code and its common use in conjunction with registers provides a logical solution to the impulsing problem, as it renders practicable the necessary conversion of the digital signals, at the incoming end, into the form required on the national network.

Control of Routing.—For the field trials, the digital information keyed by operators for routing purposes will comprise a two-digit international code, which may be used by registers at each international switching point to determine the selection of an appropriate route towards the country of destination, and the necessary digits to enable the incoming national register to determine the routing within the national network to the wanted subscriber.

Choice of Signalling Frequencies.

On the resumption of the meetings at the end of the war the C.C.I.F. considered that the introduction and large-scale employment, during the previous ten years, of telephone transmission systems having uniform frequency attenuation characteristics, and the extended use of voice frequency signalling systems for automatic switching, made it possible to plan a standard international signalling system technically very much in advance of the type of signalling system which it considered in 1938. The committee therefore decided to investigate what were the best signalling frequencies to use, bearing in mind that the signal receiver should not be operated by currents other than those of the signalling frequencies and should not be prevented from operating by the effects of noise. Tests were carried out at London, and at Zurich, on telephone circuits carrying conversations in the German, English, French and Italian languages, and with recordings of high quality speech in other European languages. It was recognised in the tests carried out in London and Zurich that the following factors, in addition to the frequencies used, have a bearing on the number of false signals that arise due to imitation of signals by speech³:—

- (a) Sensitivity of the signal detectors.
- (b) Sensitivity of the guard circuit.
- (c) The delay which is introduced in the identification of signals.

From the results of the tests made and taking into account all the varying factors, the C.C.I.F. concluded⁴ that for

obtaining relative immunity from false signals due to speech it is advisable to use a frequency of at least 2,000 c/s for signalling. Considering future conditions, a frequency of 2,600 c/s appears to be the best for transmission over modern types of transmission systems, but certain factors, notably the reduction of power which can be transmitted and the increased attenuation of certain old types of cables at the higher frequencies, make it necessary at present to employ frequencies lower than 2,600 c/s. It was therefore recommended that the signalling frequencies should lie between 2,000 c/s and 2,600 c/s. For the field trials it was agreed to use 2,040 c/s and 2,400 c/s in the 2 V.F. system and 2,280 c/s for the Single Frequency system.

Choice of Signalling Code.

The code of signals, which may be defined as the manner in which various signals are distinguished one from another, may be formulated in a number of different ways, e.g. by frequency discrimination, by the duration of the signals, or number of pulses, or by relying on the sequence in which the signals occur. Tests have indicated that signals comprising two frequencies transmitted simultaneously (compound signals) are less likely to be imitated by speech currents than would be signals of a single frequency. This has led to the development of a signalling method whereby all signals which occur when speech currents are likely to be present, are prefixed by a compound signal element the function of which is to bring about the necessary circuit conditions for the receipt of the simple frequency element of the signal. It follows with this method of signalling that as two frequencies are used for the compound signal elements, the signal code can be formulated by using different combinations of these two frequencies. The method is known as a 2 V.F. compound signalling system and it will be seen from Table 1 that a large number of signals, each having a separate identity, can be made available.

TABLE 1
2 V.F. Signalling System—Code of V.F. Signals

Forward Direction		Backward Direction	
Signal	Code	Signal	Code
Transit Seize	CY	Transit Proceed to Send	Y
Terminal Seize	CX	Terminal Proceed to Send	X
Digit Signals	Binary Code Nos. 1-(10) (See Table 3)	Digit Acknowledge Transit	y
		Digit Acknowledge Terminal	x
End of Impulsing ..	Binary Code No. (15)	End of Selection	C
		Busy Flash	CX
Access to Operator ..	Binary Code No. (11)	Ring Tone	CY
		Answer	PY
Access to Particular Operator	Binary Code No. (12)	Backward Clear	PX
		Re-answerPY
Forward Transfer ..	PXX	Release Guard	PYY
Forward Clear	PYY	Blocking	PX

NOMINAL SIGNALLING FREQUENCIES:—

$$X = 2,040 \text{ c/s}$$

$$Y = 2,400 \text{ c/s}$$

$$C \text{ or } P \text{ (Compound elements)} = 2,040 + 2,400 \text{ c/s}$$

SIGNAL TIMINGS:—

Signal Element	Sent Duration (ms)	Recognition Time (ms)
C (Short compound)	40-60	20-30
P (Long compound)	120-200	70 minimum.
x or y	20-30	—
X or Y	60-100	30-50
XX or YY	240-360	140 minimum.

³ "Influence of Signal Imitation on the Reception of Voice Frequency Signals." T. H. Flowers and D. A. Weir, *J.I.E.E.*, 96, Part III, p. 223, May 1949.

⁴ C.C.I.F. 1947/48. 8th C.E. Document No. 12.

A signal code based on the use of only one frequency tends to become complicated when a large number of signals is required and it is desired to give each signal a separate identity. It will therefore be seen in the single frequency code shown in Table 2 that for discriminatory purposes a much greater reliance has been placed on the sequence in which the signal occurs.

TABLE 2
Single Frequency System—Code of V.F. Signals

Forward Direction		Backward Direction	
Signal	Code	Signal	Code
Terminal Seize	X	Proceed to Send	X
Transit Seize	XX	Ring Tone	XSX
Digit Signals	Arythmic Codes Nos. 1–(10) (See Table 4)	Busy Flash	X
End of Impulsing ..	Arythmic Code No. (15)	Answer	X
Access to Operator ..	Arythmic Code No. (11)	Backward Clear	Train of Impulses XSSXSSX...
Access to Particular Operator	Arythmic Code No. (12)	Release Guard	XSSXX
Forward Transfer	X	Blocking	Continuous Signal
Forward Clear	XSSXX		

NOMINAL SIGNALLING FREQUENCY:—2,280 c/s

SIGNAL TIMINGS:—

Signal Element	Sent Duration (mS)	Recognition Time (mS)
X	80–120	30–50
XX	500–750	—
S (Silent interval)	80–120	—
SS (Silent interval)	250–350	—

It is not within the scope of this article to appraise the relative merits of the two types of signal code as this is one of the objectives of the forthcoming trials. Signalling equipment constructed in accordance with these two signal codes will be subjected to trial side-by-side on circuits interconnecting Amsterdam, Brussels, London, Paris and Zurich. A similar series of tests will be made on circuits linking Copenhagen, Oslo, Stockholm and Helsinki, and between Milan and Zurich, using only the two frequency code. The networks concerned are shown in Fig. 1.

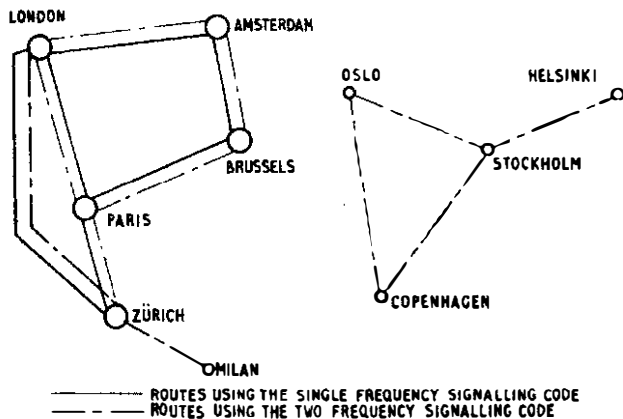

FIG. 1.—ROUTES USED FOR FIELD TRIAL.

Digit Signalling Code.

To avoid the use of separate voice frequency receivers for receiving digital signals, the digital codes in both signalling systems have been based on the use of the same frequencies

as those employed for line signals. Thus it will be seen from Tables 3 and 4 that the digital code for the 2 V.F. signalling

TABLE 3
2 V.F. Signalling System—Binary Code

Digit Signals	Binary Number	Code	Signal	Binary Number	Code
1	1	YYYY	Access to Operator	(11)	XYXX
2	2	YYXY			
3	3	YYXX			
4	4	YXYY	Access to Particular Operator	(12)	XXYY
5	5	YXXY			
6	6	YXXY			
7	7	YXXX	Spare	(13)	XXYY
8	8	XYYY			
9	9	XYYY	Spare	(14)	XXYY
0	(10)	XYXY			
			End of Impulsing	(15)	XXXX
			Spare	(16)	YYYY

NOMINAL SIGNALLING FREQUENCIES:—X = 2,040 c/s Y = 2,400 c/s

SENT SIGNAL DURATIONS:—X or Y elements — 20–30 milliseconds with 20–30 milliseconds SILENT INTERVAL between them.

There should be at least 20–30 milliseconds SILENT INTERVAL between successive digit signals.

TABLE 4
Single Frequency System—Arythmic Code

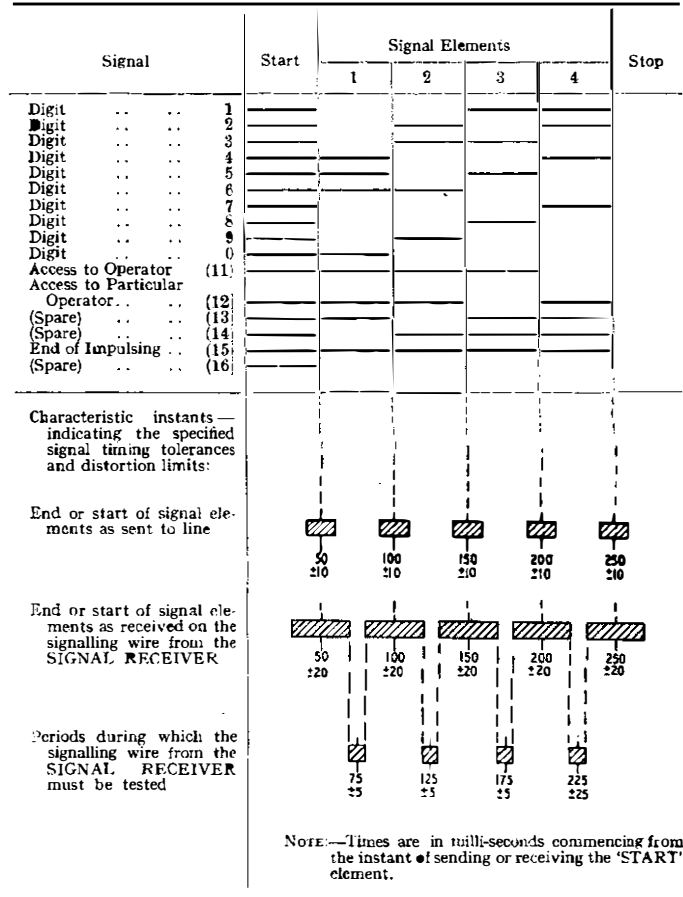

Nominal Signalling Frequency = 2,280 c/s.

system is based on the use of two frequencies and the single frequency digital code on one frequency. Both digital codes are constructed on the principle of binary numbering; the term "Arythmic" given to the single frequency digital code relates more specifically to the method of transmitting the

coded signals. In both applications each keyed digit is stored on a group of four relays, or equivalent devices, the numerical significance being indicated by the condition of the four relays, i.e. whether they are operated or released. The coding relays form part of the registers and in all groups are arranged in a similar relative order, i.e. W, X, Y, Z. The coding function is performed during the keying operation by locally applied potentials which condition the four relays in the particular operated and released combination assigned to the keyed digit. In the 2 V.F. system the codes are assigned to the digits in regular binary scale order and the relays which are operated when a group is set up correspond identically with the "X" elements of the signal to be transmitted. Thus, for example, if the digit key for the Code "11" is depressed, relays W, Y and Z operate and hold and the X relay remains in the normal released condition; the coding group then exhibits physically the number 11 in the binary form 1011 (i.e. representing $2^3 + 0 + 2^1 + 2^0$) which is transmitted by sending a pulse of the "X" frequency representing the integer "1" for each of the operated relays W, Y and Z and a pulse of the "Y" frequency indicating the integer "0" for the X relay released. These component elements of the digit signal are transmitted at a nominal 20 I.P.S. with even ratio (i.e. 25 mS ON, 25 mS OFF) and on receipt at the distant exchange each step a distributor which offers the "X" elements, but not the "Y," to the relays of a storage group in the incoming register. The storage group thus assumes an operated and released combination similar to that of the corresponding coding group in the outgoing register, and stores the binary terms of the signal suitably for subsequent recognition.

In the single frequency system the digit signals are coded during keying in a manner similar to that used in the 2 V.F. system, although the binary combinations embodied in the "Arythmic" code are, for convenience, assigned to the digits in a distinctly different order. This, however, is of no consequence so far as the method of transmission is concerned, which, as a necessary alternative to the directly controlled method employed in the 2 V.F. system, follows telegraph technique and uses "start-stop" working with separate time bases at each end. Initially the sending apparatus transmits the signalling frequency (2,280 c/s) for 50 milliseconds (nominal) to start the distant receiving equipment, and then, while testing the condition of the constituent relays of the relative coding group in W, X, Y, Z order, sends the signalling frequency for 50 milliseconds (nominal) for each relay, indicating the integer "1", in the operated condition and disconnects it for 50 milliseconds in respect of any relay, representing the integer "0", in the released condition. The signalling frequency is not necessarily interrupted when two or more relays in the group indicate integers "1" in successive order. Following the last element of the signal the signalling frequency is withheld for a "stop" period to enable the incoming equipment to reset ready to detect the next "start" signal. At the incoming end, and nominally 75 milliseconds after detecting the "start" signal, the receiving equipment inspects the signalling wire momentarily to determine whether a positive signal element is present and subsequently repeats the process three more times at equal intervals. Then, coincident with the "stop" period, this function is arrested and the next "start" signal is awaited. Meanwhile any positive signal element detected during the inspection periods is offered to the appropriate storage group in the incoming register which thus receives the binary representation of the transmitted digit, and in this case stores it either for recognition or for re-transmission in the same form as it was received. With the 1 V.F. method of digital transmission, synchronism and accurate formation of the component elements of the signals are important for reliable scanning, and whilst reasonable margins are allowed for signal

distortion, close tolerance limits are necessarily specified in regard to the speed and ratio performance of the relative sending and receiving apparatus.

Signal Transmission and Reception.

Transmission and 4-Wire Switching.—It has been agreed that the transmission loss between two subscribers on the same continent shall never exceed an upper limit of 40 db., this figure including those variations which are a function of time. Of this loss, 8.7 db. has been allocated for the loss on international connections and this has been apportioned as 7 db. maximum to the international line or combination of international lines, and 1.7 db. to variations with time which may occur on the international connection. The C.C.I.F. has recommended that transit switching should be effected on a 4-wire basis without "tail-eating", and it has been agreed that the overall loss between two international terminal exchanges on a multi-link connection shall have the same nominal value as the loss on the individual constituent circuits. Accordingly for field trial purposes the international circuits will have the customary nominal 2-wire to 2-wire loss of 7 db. and 4-wire "GO" and "RETURN" switching will be used at the international transit switching points. The insertion of pads at the 4-wire switching point is unnecessary since the circuits will be nominally 0 db., 4-wire to 4-wire.

The Signalling Levels.—For the field trials the voice frequency signals are to be sent at -6 ± 1 db. in the 1 V.F. system and at -9 ± 1 db. in the 2 V.F. system. These levels are relative to the 2-wire input to the line. Compound signals in the 2 V.F. system comprise two -9 db. tones and are equivalent to a -6 db. signal. The choice of the sending levels has been influenced by the following factors, in each system:—

- The aggregate signalling time as determined by the duration and incidence of the signals.
- The limit of 9 milliwatt-seconds per channel during the busy hour, which is imposed to avoid overloading of common amplifiers in multi-channel transmission systems.
- Considerations of channel-to-channel cross-talk in multi-channel transmission systems (peak signal levels must not exceed -6 db. for signals in the 2,000-2,400 c/s frequency range).
- The desire to obtain the best possible signal to noise ratio.

The signal durations have been determined largely by the need for a high speed of signalling; the necessity to provide suitable margins for discrimination between long and short signals; and the voice immunity considerations.

Reception of Signals.—In addition to the need for taking into account normal variations in transmission performance, allowance must be made for the effects of attenuation distortion, and an overall allowance of ± 4 db. per circuit has been considered reasonable to cover all variations. The signal receivers are associated with the 4-wire part of the international circuit and are protected from the effects of "near-end" speech and noise by a buffer amplifier connected as shown in Fig. 2. To allow for simultaneously adverse

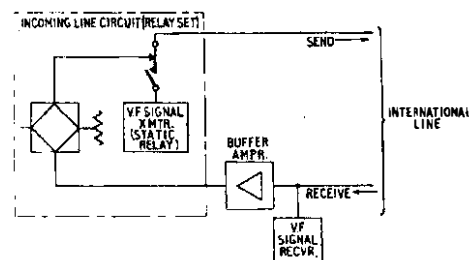

FIG. 2.—BLOCK SCHEMATIC DIAGRAM OF LINE CONNECTIONS IN LONDON ON AN ESTABLISHED CALL.

transmission conditions on 2-link connections the V.F. receivers must operate satisfactorily over a ± 9 db. level range. In the British case the signal receivers are connected at a -3.5 db. relative level point and therefore operate at -9.5 ± 9 db. in the 1 V.F. system and -12.5 ± 9 db. in the 2 V.F. system. The actual receiver performance substantially exceeds these figures. In the 2 V.F. system it is also necessary to consider the relative levels of the component frequencies in a compound signal; these are equal to within 0.5 db. at the sending end, but may differ to a greater extent at the incoming end due to attenuation distortion on the line. The receiver is accordingly required to tolerate the "X" frequency (2,040 c/s) being 6 db. higher than the "Y" frequency (2,400 c/s) and the "Y" frequency being 3 db. above the "X" frequency. The impulse distortion performance of the receivers must not exceed ± 5 milli-seconds on single frequency signals and ± 8 milli-seconds on compound signals. The receivers are required to tolerate a ± 15 c/s variation in received frequency and not to operate in response to frequencies ± 150 c/s removed from the nominal frequency. Conditions are specified for the performance of receiver guard circuits in regard to voice immunity, the avoidance of receiver paralysis by line noise, and rapid recovery from the effect of surges immediately preceding the receipt of signals.

Protection of Signals from Interference by Surges originating in the Sending Circuit.—Surges, which usually accompany the preparation of the signal sending circuit, can cause interference with the reception of the signal by the distant receiver. To prevent such interference, arrangements are made in both systems to ensure that the signalling transmission path is isolated, at the sending end, for a period commencing at least 30 milli-seconds before the signal frequency is connected and ending not less than 20 milli-seconds after the signal is transmitted. This gives the receiver guard circuit time to recover and allows the complete signal to be received during a surge-free period.

Prevention of Mutual Interference between National and International Signalling Systems.—To avoid signalling interference between systems, which might arise especially in the case where a national circuit and an international circuit, connected together, both use the same or nearly the same signalling frequency or frequencies, it is recommended that signals originating on either the national or the international circuit shall cause the transmission path to "split" at the international terminal exchange so that only a fraction of the signal "spills-over" from one signalling system into the other. The measure of the period for which the signal is allowed to "spill-over", termed the "splitting time"; has to be judiciously chosen; it is decided in part by the voice immunity performance of the system, since, if the period is too short there is a risk that voice operation of the signal receiver may cause excessive false splitting of the transmission path to occur, with consequent degradation of speech. On the other hand, to ensure that no interference occurs between inter-connected systems, the shortest signal recognition time must exceed the longest possible splitting time. Thus, a long splitting time involves long recognition times which lead to lengthy signals and, hence, to slow signalling speeds. The Field Trials Specifications also refer to the possibility that an international circuit might convey interfering signals from one national network to another, if the signalling frequency or frequencies used on the national networks were the same, or nearly the same, but different from those used in the international system.

The "splitting times" specified for the field trials circuits are 35 milliseconds maximum in the single frequency system, and 60 milliseconds maximum, compound signals only, in the 2 V.F. system. Splitting must not occur at the 4-wire switching point at transit exchanges as V.F. signals occurring when the connection is established are transmitted on an "end-to-end" signalling basis, in both systems.

(To be continued.)

Book Review

"Dimensional Analysis." H. E. Huntley, B.Sc., Ph.D. Macdonald & Co. (Publishers), Ltd., London. 158 pp. 20s.

There is probably a widespread impression that dimensions are only of interest in connection with systems of units, and to check that the results obtained by normal analytical methods are dimensionally correct. This book should help to correct this impression. Dimensional analysis may be used to obtain information about the functional relationship which must exist between the dependent and independent variables in a physical problem solely on the premise that the relation must be dimensionally correct. For example, the author shows that the manner in which the periodic time of pendulums, the flow of viscous fluids through tubes, and the movement of electrons in magnetic fields vary with the respective independent variables involved can be determined very simply in this way.

In the method of dimensional analysis employed in this book it is assumed that the dependent variable (e.g. the frequency of vibration of a stretched wire) can be represented as an infinite sum of terms, each comprising products of powers of the independent variables (e.g. the tension, length, and linear density of the wire), and constants. On the postulate that each of these terms must have the same dimensions, a dimensional equation is set up in the fundamental quantities (L, M, T, etc.). When the solution of this equation fully determines all the exponents of the independent variables, the infinite series becomes a single term. When

some of the exponents are undetermined, however, the desired relation between the dependent and independent variables must still include an infinite series or a general function. Unfortunately, this fact is sometimes overlooked in this book, and the impression is then given that only one term is required. In most of the examples this is true, but it is not proved by the dimensional analysis alone.

Following the outline of the method and a brief history of the development, the method is applied to a wide range of interesting examples. While the author rightly emphasises the value of the method as a tool, however, he is careful to point out its limitations.

Components of the length and mass dimensions are subsequently introduced, and the value of these in extending the results obtainable is illustrated.

The method is applied to problems connected with the motion of ships and aeroplanes by the use of models. Such problems are often too complex to be solved by normal analytical methods.

The last two chapters are devoted to thermal and electrical problems. The use of quantity of electricity as a fourth fundamental dimension is explained. The author states that the opportunities for application in the electrical field are less than in certain other fields, but they may not have been explored so fully.

The book is easy to read and should serve as an introduction to more advanced treatises.

R. F. J. J.

A Method of Assessing the Effect of Flexibility in Distribution Networks

S. D. MELLOR, B.Eng., A.M.I.E.E. †

U.D.C. 621.395.743:519.24

In this article the author considers the assessment of the effect of flexibility in telephone distribution networks as a statistical problem. The method of calculation used, demonstrates the general form of the relation between the degree of flexibility (given by cross-connection cabinets and pillars), the spare plant margin, and the waiting list of subscribers. By this means the effect of increasing the flexibility can be assessed quantitatively.

Introduction.

The margin of spare plant in a non-flexible local cable network is the principal factor determining the size of the "underground" waiting list, i.e. the number of applicants who cannot be given telephone service because of shortage of cable pairs. The introduction of flexibility units (e.g., cross-connection cabinets and pillars) into Post Office networks has made it possible to reduce the waiting list without the necessity for increasing the spare plant margin to the extent necessary in non-flexible networks.

Considerable economies can be realised by operating distribution networks at high cable fills, and it is therefore important to determine the extent of the reduction in spare plant margin which can be achieved by the provision of flexibility. For this purpose it is necessary to establish the relation between the degree of flexibility, the spare plant margin and the size of the waiting list.

The problem is essentially statistical in nature and a precise solution for any practical network would require a knowledge of the statistical distribution of existing and potential subscribers in all parts of the territory served by the network. Even if such a solution were feasible it would be of little interest since it would not be valid for other areas and networks with different characteristics.

An approximate solution of general application is of greater interest, and can be obtained if the following assumptions are made:

- (a) that the cable network divides the territory into statistically identical areas, and
- (b) that subscribers are distributed between these areas in a random manner.

A method of calculation based on these assumptions is described in this article, and the results obtained are presented in graphical form. Since the assumptions made are not in conformity with actual conditions, the numerical results are not sufficiently rigid for precise design purposes; they do demonstrate, however, the general form of the relation between the degree of flexibility, the spare plant margin and the waiting list, and enable the effect of increasing the flexibility to be assessed quantitatively.

It is shown that there is an optimum economic level of spare plant margin for any given degree of flexibility.

Definitions.

The following definitions are used throughout the article:—

Distribution Units. It is convenient to regard the distribution network as divided into "distribution units", each of which serves a clearly defined "distribution area". Each distribution unit is a self-contained unit, served by a separate group of main cable pairs, none of which are available to other units. Within the unit, each main cable pair can be made available to provide service in any part of the distribution area without opening plumbed joints, i.e. the unit is fully flexible.

In non-flexible cable networks, the distribution unit is simply the D.P., and the distribution area is the D.P. area.

The installation of cross-connection pillars to group together a number of D.P.s has the effect of enlarging the

size of the distribution area to the sum of the individual D.P. areas. Each pillar forms an independent distribution unit, provided that teeing between pillars is not adopted and that cabinets are not installed.

The grouping of a number of pillar areas by means of a cross-connection cabinet further enlarges the distribution area, and each cabinet can be regarded as a separate distribution unit provided that there is no multiplying of main cable pairs between adjacent cabinets. It is assumed that the cable pair provision between cabinet and pillars is on a sufficiently generous basis to justify the assumption of full flexibility within the cabinet area.

Availability. The degree of flexibility in a network is measured by the "availability" which is defined as the number of main cable pairs serving each distribution unit. In a non-flexible network the availability is the number of through pairs available at the D.P. and is usually of the order of 10.

In a fully flexible network with a complete installation of pillars and cabinets and no directly connected pillars or D.P.s, the availability may be as high as 400. Where pillars only are fitted the availability will be of the order of 50 if there are no directly connected D.P.s. At the present time, owing to the preponderance of directly connected D.P.s the average availability is very little in excess of 10.

Spare Plant Margin. The spare plant margin is defined as the percentage of spare exchange pairs in the group serving the distribution unit.

Waiting List Ratio. The number of outstanding demands for telephone service due to shortage of underground plant divided by the number of working circuits, is termed the "waiting list ratio". At the present time this figure is of the order of 0.1.

Demand. Demand is defined as the sum of the number of working circuits and the number of waiting applicants (due to shortage of cable pairs).

CALCULATIONS AND RESULTS

Assumptions.

The statistical distribution of the demand between individual distribution units does not, in practice, conform exactly to any simple theoretical distribution, due principally to the variations in telephone density throughout the territory being considered. The forecasting and planning procedures followed by the sales and engineering organisations in Telephone Areas aim at so adjusting distribution areas in accordance with the predictable variations of density, that the average demand remains approximately the same in each distribution area. If this were completely successful, all distribution areas, although varying widely in size, type of tenancy, etc., could be regarded as being identical from the point of view of telephone demand, the only variations between individual units being caused by random fluctuations. The system would be statistically equivalent to a homogeneous area with uniform average density and identical distribution units. Under these conditions the demand in any specified distribution unit will be given by the Poisson Probability

† Regional Engineer, North Western Region.

Distribution. Hence if the average demand per distribution unit is A , the proportion P_x of distribution units with a demand equal to x is given by the expression

$$P_x = e^{-A} \frac{A^x}{x!}$$

The forecasting and planning procedure is rarely, if ever, completely effective in practice, and it is usually found that the actual distribution of demand has a greater variance than the Poisson distribution, i.e. the latter under-estimates the proportion of distribution units with large values of demand. It follows that since such distribution units have large waiting lists, the use of the Poisson distribution to calculate the total waiting list figure will give a result which is likely to be smaller than would be obtained in practice and this is, in fact, found to be the case. It will, however, represent the minimum theoretical figure below which it is impossible to reduce the waiting list (without increasing the spare plant margin or the flexibility) however effective the forecasting and planning procedures.

The use of the Poisson distribution assumes that the variations from the average demand which occur in individual distribution units is in accordance with pure chance, i.e. that demands for service arise (and existing services cease) entirely at random. This implies an infinite number of potential subscribers, but except in areas of very high penetration very little error will result.

It is also assumed that any applicant who cannot be given service immediately, due to lack of cable pairs, waits until a spare pair becomes available. This is virtually in accordance with practical conditions since, although there are a number of applications which do not mature, they normally remain recorded on the waiting list until plant is available, due to the failure of the subscriber to advise the Sales staff at the time he decides to cancel his order. A direct comparison between the calculated and recorded waiting list figures is thus possible, although both figures will tend to be too high.

Method of Calculation.

The Poisson distribution formula is used to determine the waiting list ratio for values of availability of 10 and 20. The Normal, or Gaussian, distribution is used as an approximation to the Poisson distribution to calculate the waiting list ratio for availabilities of 50, 100 and 200. The combined results are given as a series of curves in Fig. 1 for values of spare plant margin up to 60 per cent.

The proportion of closed distribution units can be similarly calculated.

Details of the method of calculation used are given in the Appendix.

Check of Results.

In order to check the extent to which the assumptions made are realised in practice, a comparison of actual and calculated figures was carried out for a number of Telephone Areas over a period of years. Telephone Areas were selected as the unit of comparison as the statistics are readily available and each unit is sufficiently large to reduce sampling errors to small proportions. The availability figure used was obtained in each case by dividing the total number of through cable pairs by the number of D.P.s (this gives rise to a small error owing to the varying size of D.P.s and to the existence of a number of cabinets and pillars which tend to increase the average availability of the Area as a whole).

The calculated waiting list ratio figures (interpolated from Fig. 1) were found to be consistently lower than the actual figures, as was expected from the nature of the assumptions made. The average error per Telephone Area

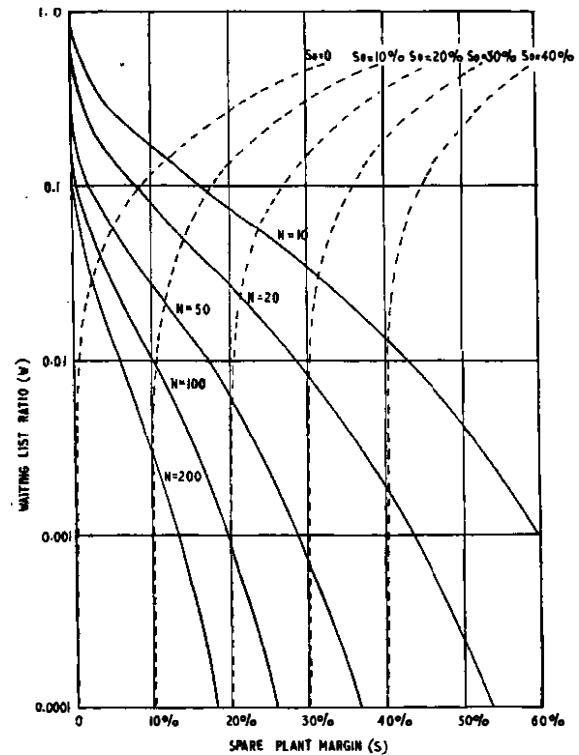

FIG. 1

was of the order of 50 per cent. Analysis of a number of waiting list records revealed, however, that the recorded waiting list figures tend to be inflated due to:

- delays in utilisation of spare cable pairs, and
- the practice of recording faulty and reserved cable pairs as spare for the purpose of statistical returns.

This results in the true values of spare plant margin and availability being less than the recorded values.

If an allowance is made for the effect of these factors, it is estimated that the discrepancy between the calculated and actual waiting list figures, which can be attributed to departures from the assumptions made, is of the order of -30 per cent. for the cases examined, i.e. approximately 70 per cent. of the waiting list can be attributed to non-predictable (random) fluctuations in demand.

THE EFFECT OF INCREASING THE FLEXIBILITY OF A NETWORK

The curves in Fig. 1 can be used to determine the effect of increasing the availability of a network. The effect can be considered from two aspects.

Short-term Effect.

The immediate effect of an increase in availability, e.g., by the provision of flexibility units, is to reduce both the number of waiting applicants and the spare plant margin (due to the increase in the number of working circuits). If the total of working circuits and waiting applicants is assumed to be constant, the waiting list ratio and the spare plant margin are related by the expression

$$W = \frac{S - S_0}{1 - S}$$

where W = waiting list ratio
 S = spare plant margin
 S_0 = spare plant margin for $W = 0$.

This expression is represented by the broken line curves in Fig. 1 for various values of S_0 . Each of these curves can be regarded as a load line corresponding to a fixed total

demand. The extent to which the demand will be met by any network is given by the point of intersection of the load line and the full-line curve corresponding to the availability of the network.

To illustrate the procedure for estimating the short-term effect of an increase in the availability of a network, consider a group of 1,000 D.P.s with an average of 10 exchange pairs per D.P. If the total demand (i.e. working circuits plus waiting applicants) is 8,000, the spare plant margin with no waiting list (S_0) would be 20 per cent. The intersection of the 20 per cent. load line with the full-line curve for $N = 10$ gives:—

$$\text{Waiting list ratio} = 0.057$$

$$\text{Spare plant margin} = 24.3 \text{ per cent.}$$

Therefore, total number of working circuits.

$$= 10,000 (1 - 0.243) = 7570$$

$$\text{Waiting list} = 7570 \times 0.057 = 430$$

If the availability is increased to 50 (e.g., by the installation of pillars) the intersection of the load line with the curve for $N = 50$ gives:—

$$\text{Waiting list ratio} = 0.007$$

$$\text{Spare plant margin} = 20.5 \text{ per cent.}$$

Therefore, total number of working circuits.

$$= 10,000 (1 - 0.205) = 7950$$

$$\text{Waiting list} = 7950 \times 0.007 = 50.$$

The effect of the increase in availability is, therefore, to reduce the number of applicants waiting for underground plant from 430 to 50.

It is interesting to note that without the use of flexibility units, it would be necessary to increase the spare plant margin from 24.3 per cent. to 47 per cent. to achieve the same result (from Fig. 1, $N = 10$). This would involve the provision of 5,000 additional exchange pairs, compared with the provision of 200 cross-connection pillars necessary to increase the availability to 50.

Long-term effect.

The short-term effect of an increase in flexibility is, as indicated above, to reduce the waiting list ratio and at the same time achieve a small reduction in spare plant margin. The long-term effect is influenced by the policy of the administration in balancing the competing claims of cost and service. If the waiting list ratio is maintained at its new low level by successive extensions of plant, there is no material economy in plant provision and the major benefit accrues to the grade of service, i.e. to the proportion of applicants who can be given service "on demand". If the waiting list ratio is allowed to rise, it is possible to operate the network at a lower level of spare plant margin, with consequent reduction in capital expenditure and annual charges. Fig. 2 shows the relation between the spare plant margin and the availability for constant values of the waiting list ratio (0.1, 0.01 and 0.001).

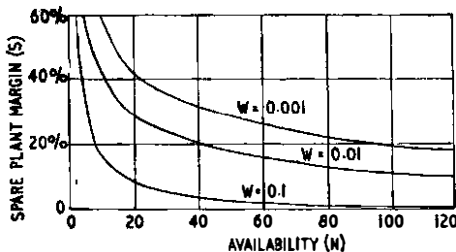

FIG. 2

margin and the availability for constant values of the waiting list ratio (0.1, 0.01 and 0.001). It is clear that considerable economies can be achieved by relatively slight increases in availability if the waiting list ratio is maintained at the same level. An increase from 10 to 20 enables the spare plant margin to be reduced from 44 per cent. to 30 per cent.

for the same grade of service (0.01). A further increase of availability to 50 gives a further reduction to 18 per cent. The savings achieved by increasing the availability above 50 are less pronounced.

Since the waiting list ratio can be regarded as a measure of the grade of service, the adoption of a standard figure as a basis of design and comparison has much to commend it from the service aspect, since it ensures reasonably uniform prospects of service for applicants in exchange areas with networks of different degrees of flexibility. It is generally accepted that the existing figures (of the order of 0.1) are too high, and this is confirmed by the economic considerations discussed in the next section.

THE OPTIMUM SPARE PLANT MARGIN

It can be seen from Fig. 1 that the change in the waiting list ratio for a given change in spare plant margin (for constant availability) becomes progressively smaller as the spare plant margin is increased. Thus for $N = 50$, an increase in spare plant margin from 10 per cent. to 15 per cent. reduces the waiting list ratio from 0.030 to 0.015, i.e. by 0.015. An increase from 20 per cent. to 25 per cent. results in a reduction from 0.0075 to 0.0025, i.e. by only 0.005. In other words, the number of additional pairs which it is necessary to provide to reduce the waiting list by a given amount (e.g., by one applicant), becomes greater as the spare plant margin is increased. This is illustrated in Fig. 3 for various values of availability. It is evident that

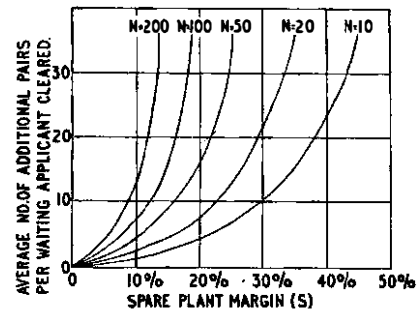

FIG. 3

there is a point beyond which any further increase in the spare plant margin becomes uneconomic, since the increase in revenue resulting from the reduction in the waiting list is offset by the annual charges on the additional pairs provided.

This point is the optimum economic spare plant margin, and represents the point at which the margin between the total revenue and the total annual charges on the underground cable network is a maximum, i.e. it is the value of the spare plant margin at which the network should be operated to obtain the maximum nett financial return. It is determined by the ratio (r) of the average revenue per working circuit to the average annual charges per through cable pair.

Table 1 gives the values of the optimum spare plant margin obtained for ratios (r) of 10, 20 and 30.

TABLE 1

Availability (N)	Optimum spare plant margin		
	$r = 10$	$r = 20$	$r = 30$
10	31%	38%	40%
20	23%	29%	32%
50	16%	22%	24%
100	12%	16%	17%
200	9%	12%	13%

The corresponding values of waiting list ratios are given in Table 2.

TABLE 2

Availability (N)	Optimum waiting list ratio		
	r = 10	r = 20	r = 30
10	0.033	0.017	0.010
20	0.020	0.0098	0.0066
50	0.012	0.0045	0.0030
100	0.0072	0.0027	0.0021
200	0.0044	0.0012	0.0012

It will be seen that the optimum values of both spare plant margin and waiting list ratio are decreased as the availability is increased.

The optimum waiting list ratios for small availabilities are too high to be acceptable on service grounds. Thus the figure for $N = 10$ is of the order of 0.02, i.e. 1 in 50, which represents a national waiting list due to shortage of underground plant of about 60,000. This fact reinforces the case for the widespread introduction of cross-connection units to increase the average availability as rapidly as possible. In order to reduce the waiting list to an acceptable level by extending existing non-flexible networks it would be necessary to increase the spare plant margin to figures of the order of 45 per cent. which would not only involve considerable capital expenditure but would be well beyond the optimum economic figure. If, however, the average availability could be increased to 50, the economic waiting list ratio of about 0.005 (1 in 200) would not only be readily realised (since it requires a spare plant margin of only 22 per cent.), but could be regarded as reasonably satisfactory on service grounds.

CONCLUSION

That there should be a waiting list of applicants for telephone service due to shortage of underground plant at a time when a considerable number of spare cable pairs exist appears to be anomalous. It is shown in the paper, however, that unpredictable (i.e. random) fluctuations in demand are responsible for the major portion (probably over 70 per cent.) of the waiting list. The relative insignificance of the predictable (i.e. non-random) fluctuations is a measure of the effectiveness of the present planning machinery. It is evident that no reduction in the waiting list can be achieved unless the spare plant margin is increased, or the degree of flexibility in the distribution network is improved. The curves showing the effect on the waiting list of varying these two factors are calculated on the assumption of random variations in demand, and, therefore, yield minimum waiting list figures which can be closely approached in practice with effective forecasting and planning procedures.

From these curves it is deduced that for any degree of flexibility there is an optimum value of spare plant margin which will yield maximum economic return. As the flexibility is increased, the optimum spare plant margin and the waiting list are both reduced, resulting in lower costs and better service.

APPENDIX

Symbols

- N = Availability, i.e. the number of cable pairs per distribution unit.
- P_x = The proportion of distribution units with a demand equal to x . (The demand is defined as the number of working circuits plus the number of waiting applicants).
- $P(>x)$ = The proportion of distribution units with a demand equal to or greater than x .

For $x < N$, x = The number of working circuits (no waiting applicants).

For $x > N$, $x = N + q$, where q = the number of waiting applicants.

$P(> N)$ = Proportion of "closed" distribution units, i.e. with N working cable pairs.

$$= \sum_{x=N}^{\infty} P_x = \sum_{q=0}^{\infty} P_{N+q}$$

S = Proportion of spare cable pairs to total pairs.

Q = Average number of waiting applicants per distribution unit.

A = Average demand per distribution unit.

= Average number of working pairs plus waiting applicants.

$$= (1 - S)N + Q \dots \dots \dots (1)$$

W = Waiting list ratio.

= Proportion of waiting applicants to working circuits.

$$= \frac{Q}{(1 - S)N} = \frac{Q}{A - Q} \dots \dots \dots (2)$$

Theory.

The Poisson distribution is assumed.

$$P_x = e^{-A} \frac{A^x}{x!}$$

and

$$P_{N+q} = e^{-A} \frac{A^{N+q}}{(N + q)!}$$

From these expressions it is possible to derive:—

(a) The proportion of closed distribution units

$$= P(> N) = \sum_{q=0}^{\infty} P_{N+q} = \sum_{q=0}^{\infty} e^{-A} \frac{A^{N+q}}{(N + q)!} \dots \dots \dots (3)$$

(b) The average number of waiting applicants per distribution unit

$$= Q = \sum_{q=1}^{\infty} q P_{N+q} = \sum_{q=1}^{\infty} q e^{-A} \frac{A^{N+q}}{(N + q)!} \dots \dots \dots (4)$$

A useful alternative expression for Q which reduces the labour of computation when tables are available can be obtained from equations (3) and (4) viz:

$$Q = A P(> N) - N P(> N + 1) \dots \dots \dots (5)$$

Calculation.

In practice the known factors are usually N and S , i.e. the availability and the proportion of spare pairs. The average demand, A , cannot be derived explicitly from N and S without a knowledge of Q , which is itself dependent on A (equation 4).

For each value of N , $P(> N)$ and Q are calculated from equations (3) and (4) for a number of values of A , use being made of the published tables of the Poisson distribution. The value of S corresponding to each value of A can then be obtained from equation (1) i.e.

$$S = \frac{N - A + Q}{N}$$

The waiting list ratio W , is calculated from equation (2).

The calculations are repeated over a sufficient number of values of A to cover the required range of values of S . Tables of the Poisson distribution are not readily available for values of A above 20. It is, however, possible to use the Normal, or Gaussian, distribution for larger values of A use being made of the fact that the standard deviation is given by \sqrt{A} .

An Instrument for Testing Subscribers' Sets in Situ

R. H. de Wardt, B.Sc. (Eng.), A.C.G.I.†

U.D.C. 621.317.74:621.395.721.1

The problem of testing subscribers' instruments in situ has been studied a number of times and various methods have been tried. Recently a new study has resulted in the production of an instrument which has been designed specifically for making a field survey of the condition of a sample of the subscribers' instruments in present use.

Introduction.

THE problem of producing equipment for testing telephone instruments in the field has been extremely difficult to solve because of the difficulty of designing portable equipment with the necessary degree of accuracy. For acceptance testing the equipment is not required to be portable and the necessary accuracy is obtained by the use of relatively complex and bulky devices. The last attempt made on the problem resulted in the introduction of the Noise Generator No. 1. During and since the war considerable advances have been made in the production of miniature components and low consumption valves and these have brought the production of more complex equipment in a light portable form within the bounds of possibility. The subscriber's set tester, which has recently been designed for a field survey of telephone instruments by staff of the Engineer-in-Chief's Office, is based on the use of these components and is an attempt to provide an instrument which will reliably test telephone instruments and provide a means of tracing transmission faults. In what follows the term "subscriber's set" includes the telephone instrument, the bell and induction coil. The conventional subscriber's set contains three distinct transmission paths, each of which may need to be tested. They are as follows:—

- (1) Transmitter to line.
- (2) Line to receiver.
- (3) Transmitter to receiver via the sidetone path.

There is a wide range of possible testing techniques available and the one chosen should be sensitive to any changes in performance which could be noticed by the subscriber. The transmission paths of the conventional subscriber's set produce various forms of distortion, one of the more important being the variation of sensitivity with frequency, and the production of a simple device that will measure the usefulness of such a transmission system for passing information, does not appear to be practicable. But it is possible to make a measuring instrument which will give an indication of the relative loudness of signals of a similar type. An example of this type of instrument is the objective sound level meter. This instrument, which is used for measuring noise levels, is actually an R.M.S. sound pressure meter which has a sensitivity/frequency characteristic similar to that of the human ear.

Thus it is possible, by using an instrument of this type, to devise a technique which will indicate the relative sensitivity of transmission paths on a loudness basis. In measurements such as this the results depend on the signal source, and therefore for the purpose under consideration the type of signal used should contain the frequency components of the useful speech band. This condition was not satisfied by the Noise Generator No. 1 which had a resonant noise source producing strong arbitrary single frequency components.

General.

A tester based on the principles discussed above has been developed. It consists of an electrical noise generator and an A.C. amplifier-voltmeter for measuring the transmission characteristics of telephone sets, together with a multi-range D.C. ammeter and voltmeter which can be used to measure

the line current and to estimate the resistance of the set. Considerable care was necessary in the mechanical design, to ensure that the tester was portable and suitable for use in subscribers' premises and in call offices where the space is very restricted.

Method of Use.

The test of the path between the transmitter and the line (Fig. 1(a)) is made by feeding electrical noise into an artificial mouth, which is a telephone receiver (of a modern, i.e., equalised, type) placed close to the transmitter, and measuring the noise voltage appearing across the line terminals of

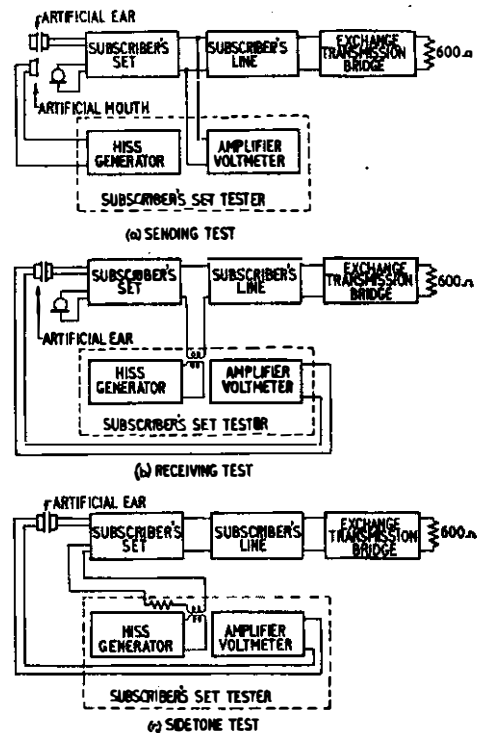

FIG. 1.—METHODS OF MAKING TESTS.

the set. To make this measurement it is necessary for the transmitter to be supplied with feeding current and, to avoid using portable batteries which would be of an appreciable size and weight, the subscriber's set is connected to the line and the normal exchange battery is used. This scheme has the disadvantage that the value of the feeding current depends on the line conditions but it does, usefully, introduce the line feed condition as part of the item under test.

The path from the line to the receiver (Fig. 1 (b)) is tested by injecting a noise voltage in series with the line and measuring the acoustical output of the receiver by means of a microphone clamped against it.

The test of the transmission round the sidetone path (Fig. 1 (c)) is made by removing the transmitter and injecting a noise voltage into the transmitter terminals. The sound developed by the receiver is then measured in the same way as in the receiving test.

† Executive Engineer, London Telecommunications Region (formerly at Post Office Research Station).

When making tests it is necessary to terminate the far side of the exchange transmission bridge with a fixed impedance in order to complete the path for the injected signals. Some impedance similar to that found in practice is necessary, and a 600-ohm non-reactive resistance is used. In all these tests the subscriber's set is connected to the line and exchange; consequently the tests give a measure of the performance of the set when connected to that particular line, i.e. the performance which the particular subscriber obtains. If the performance is abnormal in any way, further tests can be made to locate the cause of the trouble to the set or to the line.

Electrical Circuits.

Fig. 2, shows the schematic arrangement of the tester circuits. These fall into four parts: the hiss generator, the

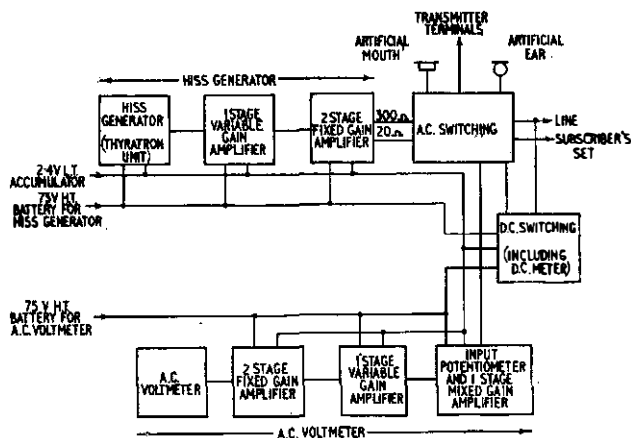

FIG. 2.—BLOCK SCHEMATIC DIAGRAM OF THE TESTER.

A.C. voltmeter, the A.C. switching unit and the D.C. switching and meter unit.

Various noise sources were considered for the tester and finally the fluctuation noise (or "hiss") produced by a thyatron in the conducting condition was chosen. A suitable miniature thyatron was available and this produces an appreciable level of noise which has a flat spectrum over the required frequency range. The noise produced by a thyatron can be increased considerably by placing it in a magnetic field. The thyatron used in the tester is fitted between the pole pieces of the magnet assembly from a conventional moving coil meter. The thyatron is followed by a three-stage amplifier with two resistance-capacitance stages and a power output stage that will deliver approximately 5V into a 300-ohm load (a power output of about 100 mW) without appreciable distortion (see Fig. 3). A weighting network is included between the thyatron and the amplifier to produce a spectrum similar to that of speech. The transformer of the output stage has two secondary windings, one to provide a 300-ohm output for feeding the telephone receiver used as an acoustical noise source and the other to provide a 20-ohm output for noise injection purposes. Negative voltage and current feedback are used to bring the output impedance to the required value. The first stage is preceded by a con-

tinuously variable gain control with a range of 10 db.; the total gain of the three stages is of the order of 50 db.

The A.C. voltmeter (Fig. 4) is required to measure the R.M.S. value of noise voltages of differing spectra and level. Fortunately the ranges of levels fall conveniently into two groups, those in the region of 1V and those 70 db. below one volt. The indicating instrument consists of a moving-coil meter associated with copper oxide rectifier circuits, similar to that employed in the Post Office speech voltmeter Type 3 (1). By a suitable arrangement of rectifier discs and resistances it is possible to produce a meter circuit with a substantially true square law characteristic (i.e. the deflection is proportional to the square of the applied voltage).

The meter circuit requires an input level of the order of 1V E.M.F. in a 300-ohm source; thus gains of the order of 70 db. are required when low levels are being measured. To obtain this gain and at the same time apply an appreciable amount of negative feedback a four-stage amplifier is used. The last three stages are identical with those used in the hiss generator, but they are preceded by a special single-stage amplifier. The input to this single-stage amplifier is taken through calibrated range controls covering 40 db. in 2-db steps and then to the grid of the valve through a step-down transformer. The problem of adapting the circuit to real voltages in the region of 1V and 70 db. below 1V was solved by taking the input direct on to the calibrated range control for the low-level measurements and through a pad and step-down transformer preceding the range control for the high level measurements. The sensitivity/frequency characteristic of the voltmeter is designed to meet the specifications of the American Standards Association for sound-level meters. The characteristic used is, in fact, that specified for faint sounds (40 db. ear weighting).

When making measurements, the circuit between the subscriber's set and the line is looped into the tester. To simplify the testing procedure the various circuit conditions are set up by three rotary switches. The first controls the hiss generator output connections, the second the line and set connections, and the third the A.C. voltmeter input connections. This last switch also inserts or removes the step-down transformer and pad as necessary.

The D.C. switching and meter unit contains a D.C. milliammeter and a control switch, which allows it to be used as an ammeter for measuring the line current and as a voltmeter for measuring the voltage across the subscriber's set and to check the H.T. and L.T. batteries.

(1) "Design of Square-Law Rectifier Circuits for Measuring Instruments." *P.O.E.E.J.*, Vol. 43, p. 74.

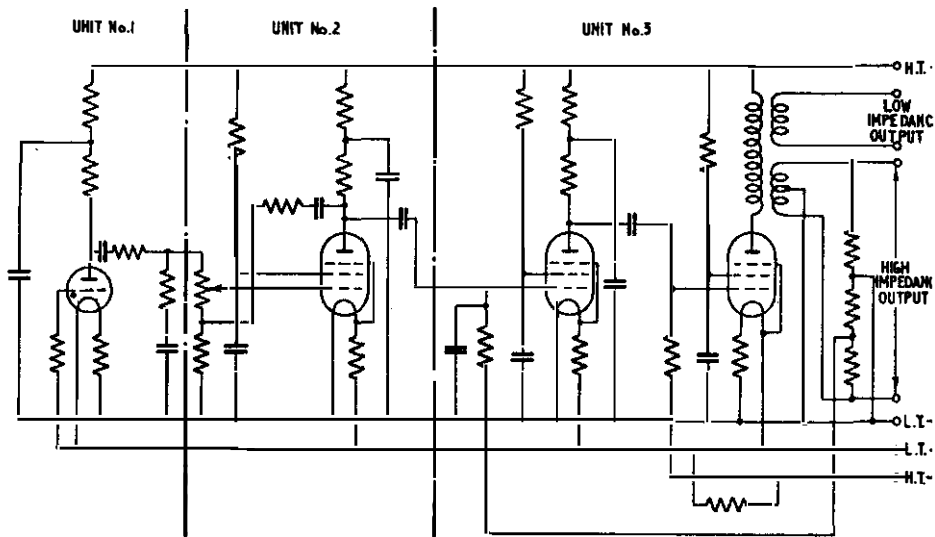

FIG. 3.—CIRCUIT OF HISS GENERATOR AND AMPLIFIER.

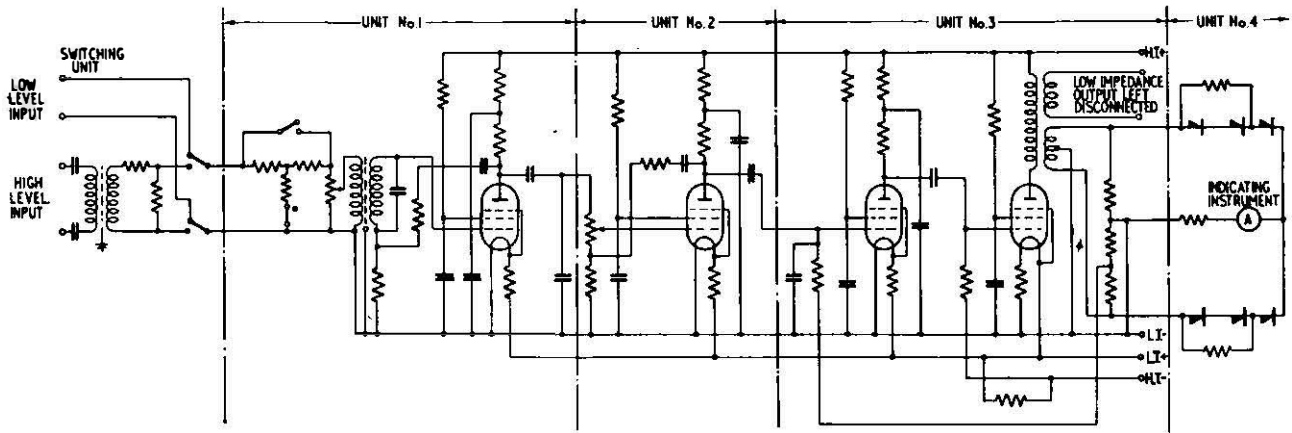

FIG. 4.—CIRCUIT OF A.C. VOLTMETER AND AMPLIFIER.

Mechanical Arrangement.

The conditions of use of the tester make it necessary for it to be as light as possible, but at the same time able to withstand considerable mechanical shock. An experimental model was built using a case made of welded silicon-aluminium angle with duralumin panels. Later models have been made in a case built from a proprietary system of construction, which incorporates rounded edges and corners and overcomes the possibility of damage to subscribers' premises which existed with the sharp corners on the first model. The case is further protected by moulded rubber pads which are mounted on all faces.

The complete equipment consists of two cases, a small one which holds the H.T. batteries and the L.T. accumulator and a larger one which holds the tester and all the cords and fittings. The large case is in two halves, one containing the tester, the other the cords and other fittings, the two halves being held together by snap fasteners. The part used for the tester is fitted with channel section bars which run lengthwise, with their upper surface $\frac{3}{4}$ in. above the bottom platform mounting the electrical components.

A panel type construction was adopted for all the electrical equipment and physically small components were used wherever possible (see Fig. 5). The components of each unit are mounted on a bakelite panel $\frac{1}{8}$ in. thick and $4\frac{1}{2}$ in. wide, the length varying with the type of unit from 2 in. to

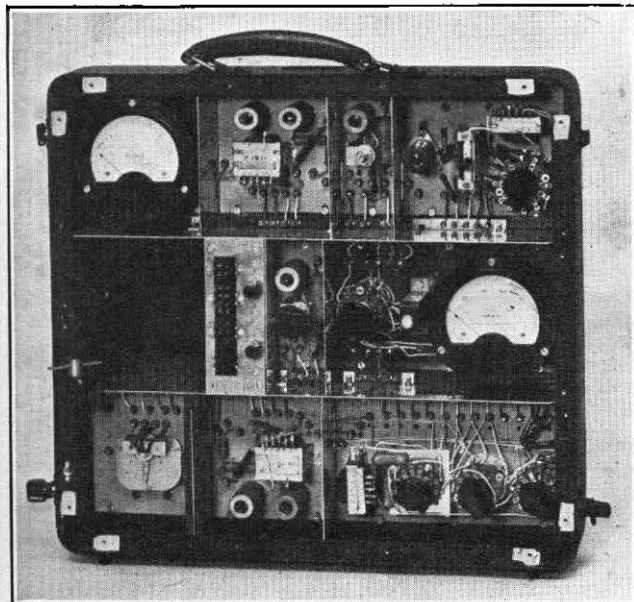

FIG. 5.—INSIDE OF TESTER.

8 in. The components are mounted on both sides of the panels, which are fitted with turret tags at the appropriate points. The panels are coated with a thin layer of metallic zinc for screening purposes. The larger components such as valves (mostly B7G types) and transformers are mounted on the upper sides of the panels; rotary switches are fitted with the locators fixed to the panel, the wafers above the panel and the knob above the wafers; for gain controls, miniature potentiometers mounted on brackets are used. The controls and meters all project above an engraved face plate. Fig. 6 shows the tester set up for testing a telephone.

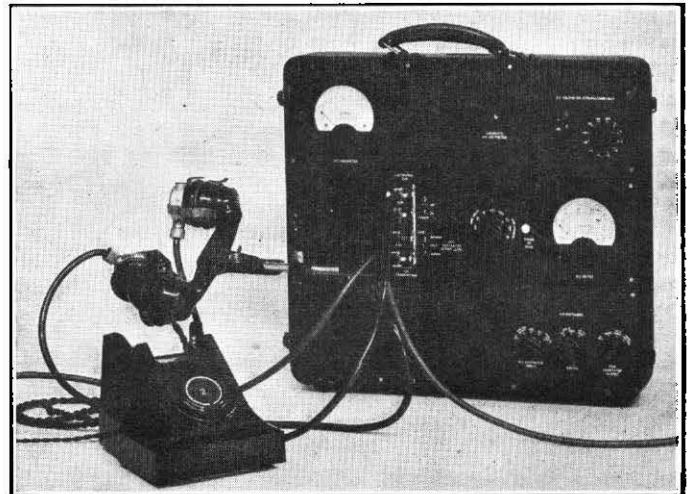

FIG. 6.—TESTER IN USE.

Three batteries are required in all, two H.T. batteries (Batteries, Dry, No. 12) and an alkaline accumulator for the L.T.

FUTURE WORK

The tester has been designed for use in a field survey of the condition of telephone instruments, and is not, in its present form, intended for general use in the field. If the survey shows that such an instrument is necessary, further development may lead to the production of a simpler and more compact tester. For this development the very low consumption valves now being used in hearing aids may be of considerable use.

ACKNOWLEDGMENTS

The author wishes to acknowledge his thanks to Mr. F. A. Wilson and those of his colleagues at Dollis Hill and in the London Telecommunications Region who have given advice and help in the preparation of this article.

The European V.H.F. Broadcasting Conference, Stockholm, 1952

U.D.C. 061.3: 621.396.97: 621.3.029.6

It was at one time thought that frequencies above about 30 Mc/s would not travel beyond the horizon. International conferences had been held to plan the medium and high frequencies which can cause interference at great distances, but it was not envisaged that this would be required for the Very High Frequencies (30-300 Mc/s).

Experience has shown, however, that this was not correct and that fields sufficiently strong to cause objectionable interference might be set up for a certain percentage of the time at distances of several hundreds of miles.

The question of the planning of the frequencies of European television stations was first mooted at a meeting of No. 11 Study Group of the International Consultative Radio Committee (C.C.I.R.), which had been charged with the study of television problems, particularly that of system standardisation. Since the C.C.I.R. by its terms of reference is forbidden to discuss frequency allocations, the initiative was taken by the Swedish Administration to call a special conference of countries of the European area to consider the problem as applied to the broadcasting bands 41-68 Mc/s (Band I), 87.5-100 Mc/s (Band II) and 174-216 Mc/s (Band III), and as a result the European Very High Frequency Broadcasting Conference met, under the auspices of the International Telecommunication Union, at Stockholm on the 28th May, 1952.

In order to be able to plan, on a logical basis, the frequency allocations of a number of radio stations, it is necessary to know the propagation characteristics of the band of frequencies concerned and the minimum ratio of wanted to unwanted field strengths, known as the protection ratio, for co-channel, adjacent channel and overlapping channel operation, which will give a satisfactory service if it is exceeded for a large percentage of the time of operation.

The question of propagation was being studied by Study Group No. 5 and the problem of protection ratios for television by Study Group No. 11 of the C.C.I.R., and it was arranged for these two Groups to meet just before the conference. Fortunately, agreements, albeit informal in status, were arrived at which proved to be of great value to the conference itself, since most of the tools of television plan-making were thus available before the conference started. It is probably true to say that these tools were forged in this country by the D.S.I.R., the B.B.C. and the Radio Branches at Dollis Hill and Alder House by much hard labour during many months preceding the conference, and were sharpened by the C.C.I.R. Study Groups and by the Technical Committee of the conference itself.

The conference was attended by 31 countries of the European region, including the U.S.S.R. and its satellites. Comparatively little time was spent on the political and quasi-political discussions which in past conferences have been so long and fruitless. Such matters as the status of East and West Germany, the languages to be used and the general principles on which frequencies should be allocated, always an important feature of the Soviet approach to these problems, were dealt with in businesslike fashion and resolved by means of voting procedure, so that the real planning work of the conference was not impeded. The United Kingdom delegation was unfortunately somewhat embarrassed in its attitude to the conference by political considerations. The new White Paper on Broadcasting was published only a week before our departure for Stockholm, and since the Television Advisory Committee envisaged therein had not been set up, and since that body had to be left quite unprejudiced in its consideration of the future development in this country of V.H.F. sound and television including sponsored programmes, it was not possible for



THE CONFERENCE IN SESSION. U.K. DELEGATION IN RIGHT FOREGROUND.

the United Kingdom to enter into any commitments for Bands II and III. On the other hand, a refusal to co-operate would have been very dangerous since we might have been faced with a European plan which took no account of our possible needs, and which was perhaps based on technical principles of which we did not approve. As soon as it became clear that the Western European countries were intent on planning, it was decided in our own interests to make sure that the plans were made on sound lines, even though we could not accept them ourselves.

The actual planning work was organised by dividing the work into Regional blocks, with arrangements for the necessary liaison between them, and thus all the delegates were able to take part in the actual planning work. The problem was much easier than for Medium and High Frequencies since channels could be shared much more often and the frequency spectrum available is much wider. Interesting problems were, however, raised by the fact that four different television standards had to be allowed for, with channels 5, 7, 8 and 13·15 Mc/s wide respectively, and by the fact that the United Kingdom, not having resolved the vexed question of amplitude versus frequency modulation for the V.H.F. sound services, was under the necessity of making alternative plans for these two methods of working. Fortunately, these problems had been foreseen and the United Kingdom had in the preliminary work preceding the conference accumulated the requisite data to meet all contingencies.

Early in the conference the Soviet delegation produced complete frequency allocation plans for Europe based on what they regarded as equitable principles. This was a theoretical systematic siting plan which had no regard for topography or relative density of population. The plan envisaged an extension of Band III by 30 Mc/s and the siting of stations in quite inappropriate positions, and was not acceptable to the conference. There was no objection, however, to its use by the Soviet countries in so far as it applied to them and could be worked into the plans for the rest of Europe, and so long as the use of out-of-band frequencies could be regularised. Certain European countries also wished to use frequencies outside the broadcasting band and since the conference had not the power to modify the Atlantic City Frequency Tables, it was decided to deal with this in a Protocol attached to the main Agreement. Only those frequencies for which the neighbouring countries likely to suffer interference had expressed their agreement were included, and it was laid down that the

stations could work only on the basis of non-interference with the other legitimate occupants of the band. In the event, since the Agreement and the additional Protocol were not signed by the U.S.S.R., their out-of-band stations did not appear in the list.

In addition to their responsibilities for broadcasting services the delegation had also to watch the interests of the Fighting Services, the Ministry of Civil Aviation, the Home Office and the Post Office, all of which have radio services at present operating in these frequency bands. In the result by dint of much concentrated work carried out, for a conference of this type, with a remarkable amount of goodwill and co-operation, firmly based plans were formulated for all three bands. The bands were allocated as follows:—

Band I Mixed Sound and Television, the frequency assignments for Sound being in the Soviet countries.

Band II Sound.

Band III Television.

The television assignments in Band I were completely satisfactory to the United Kingdom inasmuch as they provided satisfactorily for the ten stations already planned, plus two minor additions which may be required in the future. The plans for Bands II and III were also satisfactory as safeguarding our interests in those bands, but could not be accepted without prejudicing the findings of the Television Advisory Committee.

The Agreement was signed by 21 out of the 31 countries who attended the conference. The United Kingdom signature was qualified by a complete reservation as regards Bands II and III. The countries not signing were the U.S.S.R. and its eight satellites, on the grounds that the plans had not been based on any agreed principles and in spite of the fact that all their requirements had been met, and Portugal, who had not reached a sufficiently advanced stage in her consideration of her future needs.

In conclusion it can be said that the result can be regarded as satisfactory to us, since it met our difficult domestic situation without sacrificing the future, and to Europe generally, in that it laid down a well engineered pattern for future development of V.H.F. sound and television services.

The United Kingdom delegation had representatives from the Engineering and Overseas Telecommunications Departments of the Post Office, the B.B.C., the Fighting Services and the Foreign Office.

H. F.

Book Reviews

“Einführung in die Theoretische Electrotechnik” (Introduction to Theoretical Electrotechnology).—In German. K. Küpfmüller. Springer Verlag. Berlin. 441 pp. 474 ill. DM27·60.

This is a new and greatly extended edition of a book which was first published in 1932 and has come to be regarded in Germany as a standard textbook on this subject. The work may be divided roughly into three sections, the first of which deals with stationary electric and magnetic fields. The second section deals with slowly-alternating or quasi-stationary fields in which it is still possible to ignore the effects of radiation, while the third is devoted to rapidly-alternating fields and electromagnetic wave propagation.

Practical applications of the theory are discussed at each stage and illustrated by numerical examples. V. G. W.

“Alkathene.” Imperial Chemical Industries Ltd., Plastics Div. 44 pp.

This small book gives a very useful survey of the chemistry and physics of “Alkathene,” which is the I.C.I. brand of polythene. Data of all kinds are included in such a form as to be easily understood and applied by any user or potential user of the material.

Although the telephone engineers’ greatest interest in this substance is probably as a cable dielectric or sheathing, it is stimulating to know of the wide range of non-electrical uses to which it is put. The greater part of the book describes the properties of the product, but there is a very useful section on techniques of handling the material during fabrication.

The book is excellently produced and very readable.

C. E. R.

A Simple Tester for Adjustment of Polarised Relays

M. C. STONE†

U.D.C. 621.318.522:001.42

Increasing use of the polarised relay for reliable response to signals of low current values and for repetition of impulses with the minimum distortion, has indicated the need for a simple means of checking the adjustment of the relay. This article describes a tester suitable for this purpose.

THE performance of the polarised relay depends upon its correct adjustment, and, with the latest type¹, a jack-in arrangement allows the relay to be removed from the main equipment for adjustment purposes. Due to the sensitive nature of the relay its adjustment is liable to be affected by transport, and it is essential, therefore, to have a facility for checking adjustment at installations where the relay is in use.

A model tester with a relay in position for test is illustrated in Fig. 1. At the top of the case is fitted a jack for

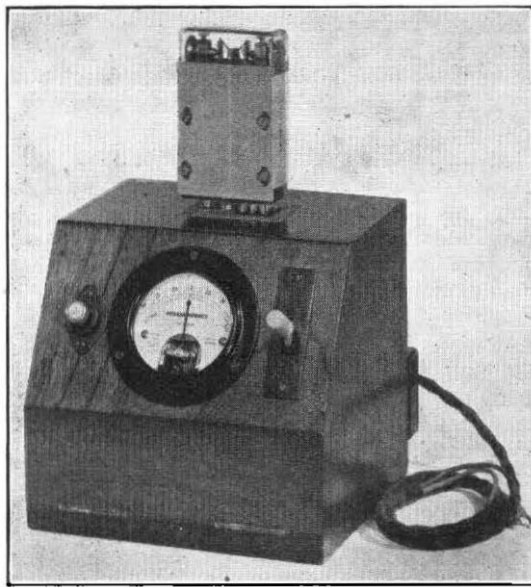

FIG. 1.—TESTER WITH RELAY IN POSITION.

inserting the relay, wired so that the deflection of the needle of the meter, fitted in the front, is in the same sense as the movement of the relay armature. To the left of the meter is fitted a non-locking key for increasing the sensitivity of the meter, under which condition a bias of 0.1 mil can be detected. The test start key is fitted on the right, while the plug and cord permits connection to a standard battery jack of 50 V supply from which the tester is operated. Resistors and capacitors which form the other components are enclosed in the case. Future models will include keys for testing side stability, as shown in the circuit diagram, Fig. 2.

Adjustment of the relay is made on one coil only because a mechanical check is the only function of the tester and the magnetic circuit is common to all coils. Circuit design has been based on operation of the relay with the minimum current. Two factors can influence the performance of the relay: the position of the armature relative to the pole faces of the magnetic circuit, and the position of the centre contact relative to the two side contacts. As the function of the relay is to reproduce signals induced in the coil, in the form of make and break of the contacts, it can be assumed

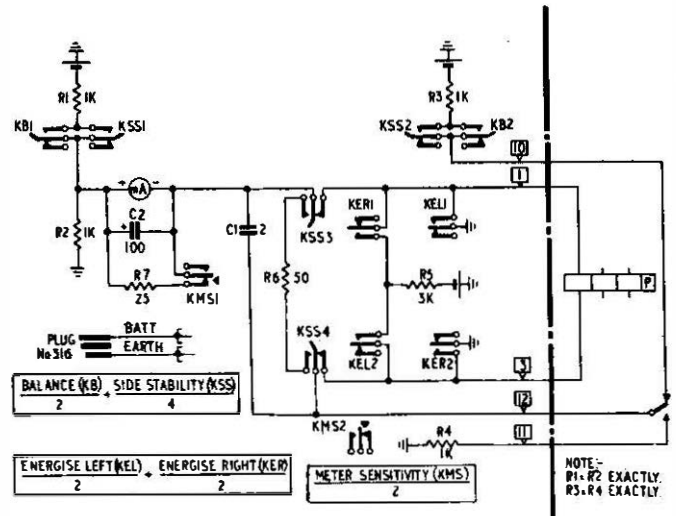

FIG. 2.—CIRCUIT DIAGRAM OF RELAY TESTER.

that it has correct neutral adjustment if the effect of the relay contacts is shown to be equal and opposite, i.e. a nul reading of the milliammeter is obtained.

With the bias test key (KB) operated, current flows either via R4, relay contact, relay coil, meter and R1, or via R2, meter, relay coil, relay contact and R3. The sense of the current is arranged to operate the moving contact to the opposite side, and the relay continues to vibrate if it is within the limits of neutral adjustment obtainable by manual inspection. A preponderance of intermittent current in either direction is due to a biased adjustment of the relay, and a corresponding bias is indicated by the needle of the meter. The current through the meter is controlled by resistor R7, and operation of key KMS, when a reading approaching zero is indicated, allows a final adjustment of the relay contacts to an accuracy of 0.1 mil. Capacitor C2 acts as a smoothing device, reducing vibration of the needle.

To provide a standard tester for relays with coils of varying resistances, values for R1, R2, R3 and R4 have been selected for the most stringent conditions anticipated, and to control induced voltages at the relay contacts, capacitor C1 has been selected to give the best mean result.

A test for side-stability is provided by operation of key KSS which connects the relay contact and meter in series. Deflection of the needle indicates that the moving spring is making contact with either the left or right side contacts. Key KEL (or KER) of non-locking type, connects the relay coil in series with resistor R5 and battery which permits operation of the armature to the left or right respectively, a check that the relay will remain side-stable after operation to either side.

The tester described should form a useful aid for the maintenance of circuits employing polarised relays at smaller centres. It does not provide for the measurement of transit time nor does it afford means of checking contact gaps as, for instance, by a measurement of transit time. Where precise adjustments of this kind are being made a more elaborate tester will be used, normally at centres where a large quantity of polarised relays is in use.

† Senior Executive Engineer, Telephone Development and Maintenance Branch, E.-in-C.'s Office.

¹ P.O.E.E.J., Vol. 43, p. 85.

Notes and Comments

Birthday Honours

The Board of Editors offers congratulations to the following members of the Engineering Department honoured by H.M. the Queen in the Birthday Honours List:—

Belfast Telephone Area	.. Pitts, H. A.	.. Technician I	.. British Empire Medal
Engineering Department	.. Wood, J.	.. Executive Engineer	.. Member of the Order of the British Empire
Exeter Telephone Area	.. Grainger, E.	.. Technician II B	.. British Empire Medal
London Telecomms. Region	.. Hughes, J. W. J.	.. Technical Officer	.. British Empire Medal

Awards by Institution of Electrical Engineers

The Board notes with pleasure that the following members of the Engineering Department have been awarded Premiums for papers during the 1951-52 Session:—

The John Hopkinson Premium.

T. H. Flowers, M.B.E., B.Sc. "Electronic Telephone Exchanges."

The Ambrose Fleming Premium.

T. Kilvington, B.Sc., F. J. M. Laver and H. Stanesby. "The London-Birmingham Television Cable System."

Non-Section and Radio Section Premiums.

J. E. Flood, B.Sc.(Eng.), and J. R. Tillman, Ph.D. "Cross-talk in Amplitude-Modulated Time-Division-Multiplex Systems."

G. H. Metson, M.C., Ph.D., M.Sc., S. Wagener, Dr.Phil., M. F. Holmes, B.Sc., and M. R. Child. "The Life of Oxide Cathodes in Modern Receiving Valves."

W. J. Bray, M.Sc.(Eng.). "The Travelling-Wave Valve as a Microwave Phase-Modulator and Frequency-Shifter."

Competition Arranged by The Physical Society

The Physical Society's 1953 Competition for apprentices and learners engaged in work connected with the design or manufacture of scientific instruments is open to competitors under 22 years of age on 31st March next. The various classes of work which may be offered include Scientific Instruments and Components, Tools and Gauges, Patterns and Functional Scale Models of Scientific Interest, and Draughtsmanship. Three Prizes (10 guineas, 5 guineas, and 2½ guineas) are awarded in each section of the competition. Entry forms and copies of the regulations may be obtained from "The Secretary, The Physical Society, 1 Lowther Gardens, Prince Consort Road, London, S.W.7." The last date for receiving entry forms is 21st February, 1953.

Institution of Post Office Electrical Engineers

Essay Competition 1952-53

To further interest in the performance of engineering duties, and to encourage the expression of thought given to day-to-day departmental activities, the Council of the Institution of Post Office Electrical Engineers offers five prizes, a first prize of Five Guineas and four prizes of Three Guineas, for the five most meritorious Essays submitted by members of the Engineering Department of the Post Office below the rank of Inspector. Draughtsmen Class II, with less than five years' service on that grade, are also eligible to compete. In addition to the five prizes the Council awards a limited number of Certificates of Merit. Awards of prizes and certificates made by the I.P.O.E.E. are recorded on the Staff Dockets of the recipients. An essay submitted for consideration of an award in the Essay Competition and also submitted in connection with the Associate Section I.P.O.E.E. prizes, will not be eligible to receive both awards.

In judging the merits of an essay, consideration will be given to clearness of expression, correct use of words, neatness, and arrangement, and although technical accuracy is essential, a high technical standard is not absolutely necessary to qualify for an award. The Council hopes this assurance will encourage a larger number to enter. Marks will be awarded for originality of essays submitted.

Hints on the construction of an essay can be obtained, if desired, upon application to the Secretary at the address given below. Copies of previous prize-winning essays have been bound and placed in the Institution Central Library. Members of the Associate Section can borrow these copies from the Librarian, I.P.O.E.E. (G.P.O.), Alder House, London, E.C.1. Competitors may choose any subject relevant to current telegraph or telephone practice.

Foolscap or quarto size paper should be used, and the essay should be between 2,000 and 5,000 words. An inch margin is to be left on each page. A certificate is required to be given by each competitor, at the end of the essay, in the following terms:—

"In forwarding the foregoing essay of..... words, I certify that the work is my own unaided effort both as regards composition and drawing."

Name (in Block Capitals).....

Departmental Address.....

Signature.....

*Rank.....Date.....
(*If a Draughtsman Class II, state date of appointment to that grade.)

The essays must reach The Secretary, The Institution of Post Office Electrical Engineers, G.P.O. (Alder House), London, E.C.1, by the 31st December, 1952.

The Council reserves the right to refrain from awarding the full number of prizes or certificates if in its opinion the essays submitted do not attain a sufficiently high standard.

H. E. WILCOCKSON,
Secretary.

Additions to the Library

2032 *A Handbook of Employment Interviewing.* J. M. Fraser (Brit. 1951).

A practical handbook for those engaged on finding the right man for the job, or in making the best use of available manpower.

2033 *Applied Electricity.* H. Cotton (Brit. 1951).

Primarily based on Part I of the London B.Sc.(Eng.) degree; also suitable for joint Section A of I.E.E. and I.C.E., for C. & G. intermediate grade and for O.N.C.

2034 *Fundamentals of Technical Electricity.* H. G. Mitchell (Brit. 1952).

A complete course in the fundamental principles upon which the ever widening field of applied electricity is based.

2035 *Principles of Lighting.* W. R. Stevens (Brit. 1951).

Describes the principles underlying different types of lighting installation and gives examples of current good practice.

- 2036 *Radio Engineering*. Ed. R. C. Norris (Brit. 1951).
A complete guide for all concerned with radio maintenance, production and development.
- 2037 *Engineering Graphics*. J. T. Rule and E. F. Watts (Amer. 1951).
A new approach that considers the subject from both the analytical and representational viewpoints, and stresses the power of graphical analysis without the domination of professional details and standard practices in special fields.
- 2038 *The Design of Switching Circuits*. W. Keister, A. E. Ritchie and S. H. Washburn (Amer. 1951).
Presents the fundamental principles underlying the design of switching circuits, no previous knowledge of switching being assumed.
- 2039 *A.C. in Telecommunications*. W. T. Palmer (Brit. 1952).
A non-mathematical introduction for students.
- 2040 *Examples in Applied Mechanics*. Admiralty (Brit. 1938).
Issued as an aid to students at the R.N. Colleges and Dockyard Schools.
- 2041 *Fundamental Principles of Ionosphere Transmission*. D.S.I.R. and Admiralty (Brit. 1948).
Provides a background knowledge of the fundamental principles for those interested in short-wave communication.

- 2042 *Post Office 1951* (Brit. 1952).
A review of Post Office activities during 1951.
W. D. FLORENCE,
Librarian.

London Centre

The programme for the first half of the 1952-53 session is as follows:—

Ordinary Meetings†

7th October, 1952.—Chairman's Address. "Engineering and the Postal Services."

11th November, 1952.—"Subscriber Trunk Dialling." D. A. Barron, M.Sc.(Eng.), A.M.I.E.E.

5th December, 1952.—"The London-Wenvoe Experimental Radio Link for Television." W. J. Bray, M.Sc.(Eng.), A.M.I.E.E., R. L. Corke, A.M.I.E.E., and R. W. White, B.Sc., F.Inst.P., A.M.I.E.E.

Informal Meetings‡

29th October, 1952.—Vice-Chairman's Address. "Some Aspects of Local Line Utilisation."

26th November, 1952.—"Mechanical Aids." G. A. Probert, A.M.I.E.E. (Midland Region).

† Held at the Institution of Electrical Engineers, Savoy Place, Victoria Embankment, W.C.2, commencing at 5 p.m.

‡ Held in the Conference Room, 4th floor, Waterloo Bridge House, S.E.1, commencing at 5 p.m.

Associate Section Notes

Harrogate Centre

The Annual General Meeting of the Harrogate Centre took place on Wednesday, 20th August, when the Chairman, Secretary and Committee for the coming winter Session were elected, and the programme decided upon.

The Chairman will be Mr. J. T. Winspear, Secretary Mr. L. Webster, and the Committee, Messrs. P. H. George, T. A. Richmond, T. B. Bagley, A. King and W. P. Johnson.

The programme arranged was as follows:—

17th September.—Visit to works of Cable & Plastics, Ltd.
15th October.—"U.A.X. 14," P. Horrocks, Stone Training School.

November.—"Naval Battle Tactics through the Ages," A. King.

January.—"Maintenance Control Procedure," D. C. Cox, Stone Training School.

February.—"British Railways' Film Show."

March.—"G.E.C. SE 50 Selector," J. P. Allen, Harrogate Training School.

April.—"Service Observations," J. T. Winspear.

After the programme had been arranged, the remainder of the evening was devoted to an exhibition of films loaned by the Petroleum Film Bureau.

With such a varied and interesting programme, it is anticipated that a really successful Session will result.

J. T. W.

Darlington Centre

The Annual General Meeting was held on 7th August, 1952.

The Secretary reported that there had been an average attendance of 30 members at the meetings held in a most successful Session.

Officers elected for the 1952/53 Session are as follows:—

Chairman, W. Gosling; *Vice-Chairman*, N. V. Allinson; *Secretary*, C. N. Hutchinson; *Treasurer and Librarian*, B. Midcalf. *Committee*, R. W. Cowen, D. E. Dodds, G. A. Garry, T. L. M. Hebron, K. Johnson, R. Moore, E. Pinkney, H. Richmond, H. Richardson, A. Snowden, D. Watson, W. L. Young. *Auditors*, A. S. Hyatt and J. Ronaldson.

The Chairman announced that Mr. J. S. Gill had relinquished his post of Section Liaison Officer and that Mr. J. N. Parker had taken over.

Mr. Gosling paid tribute to Mr. Gill's services to the Associate Section and his remarks were endorsed by the secretary (Mr. C. N. Hutchinson) who stated that he was aware of Mr. Gill's great interest in Associate Section activities and the success of the two Centres in the area was due in no small degree to his endeavours.

Mr. Gill, who attended the meeting, responded and wished the Centre well.

Programme arrangements are in progress and one notable date, *Wednesday*, 8th October, 1952, has been booked for the visit of the President of the Associate Section, Colonel C. E. Calveley, O.B.E.
C. N. H.

Middlesbrough Centre

Our Centre activities during the summer months included two visits, the first visit being to the Imperial Chemical Industries Works, Billingham, where the able description given to our party by the staff in attendance was greatly appreciated. On the second visit, which was to the repeater station, carrier and power plant rooms at Middlesbrough, members saw the practical side of Mr. W. J. Costello's paper entitled "Repeater Station Power," which he gave during the last Session. The party was conducted by Messrs. E. A. Clark, J. L. Borrett and W. J. Costello, their remarks proving most informative.

It is hoped that the programme which is to be finally arranged at a committee meeting to be held shortly will embrace the interest of all members. The following items are to be included:—

Film Show and Open Night.

A paper by G. Dale (Darlington member).

The Electronic Organ, by E. O. M. Grimshaw (Middlesbrough member).

Remote Control Siren System E, by E. R. Trotter.

Television, by K. Sergeant, B.Sc.

Two-Way Quiz: Darlington v. Middlesbrough.

We hope that Darlington Centre are successful in their efforts to arrange for the President to pay a visit to Darlington for the mutual benefit of both Centres.

We take this opportunity to remind all members of the staff interested in the activities of the Associate Section that our committee will gladly give any information regarding enrolment, etc., which may be required.
J. B.

Birmingham Centre

The programme for the 1952/53 session of this Centre has now been arranged and commenced with a visit to the Crewe works of British Railways on Sunday, 17th August.

Our Deputy Telephone Manager, Mr. S. H. Croft, agreed to open the programme of talks on 17th September with one entitled "The Traffic, Sales and Clerical Aspects of a Telephone Manager's Office." The visit arranged for that month was to the B.B.C. Television Transmitter at Sutton Coldfield. In October, Dr. A. M. Uttley, of the Ministry of Supply T.R.E., Malvern, will be talking on "Digital Computing," while two visits to the Theatre Royal have been arranged for the purpose of seeing the stage and electrical gear in use there.

(Continued on p. 142)

Regional Notes

South-Western Region

TELEPHONE SERVICE FOR ROYAL AGRICULTURAL SHOW, 1952

Telephone service for the Royal Agricultural Society's Show was provided in July this year at Stover Park, some 2½ miles from Newton Abbot. The show ground covered 110 acres, situated on either side of the main road from Newton Abbot to Bovey Tracey. This road was closed to ordinary traffic during the four days of the show and the week preceding it.

In previous years it has been considered necessary to install a manual exchange of group centre status on the show ground in order to deal with the very heavy traffic, most of which is trunk traffic. In an effort to reduce costs a manual exchange on the show ground was dispensed with on this occasion, and all lines were connected direct to Torquay non-director exchange, some 10 miles distant. Consequently, all lines were well above existing signalling and transmission limits.

Advantage was taken of spare conductors in 20-lb. loaded and balanced cable for a distance of 7.243 miles, which was extended to the show ground by 2.426 miles of P.C.Q.T. 20-lb. unloaded cable. The route distance from Torquay M.D.F. to the M.D.F. on the show ground was thus 9.669 miles, and, with

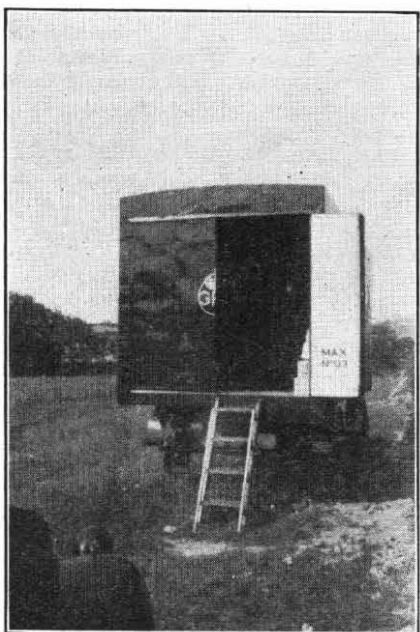

MOBILE M.D.F. ON SHOW GROUND.

the addition of the pairs in the show ground distribution network, all lines had an overall line loop resistance of approximately 950 ohms. Both direct exchange lines and shared service with separate metering were catered for, using telephones No. 332 and 310, respectively.

The total number of connections was as follows:—

Direct exchange lines	104
Shared service with separate metering	34
Kiosks	32
Service lines	4
Teleprinters	4

together with 30 external extensions on the show ground.

Due to the nation-wide scourge of foot and mouth disease the demand for telephone service was not so great as in previous years, nor was the volume of traffic; nevertheless, the amount of traffic was considerable.

Due to the absence of a special Royal Show exchange and the excellent speed of answer on the part of the Torquay telephonists, the P.B.X. operator on the Royal Society's P.B.X., with its seven exchange lines and 32 extensions, found that his calls were more speedily dealt with.

As a precautionary measure, the adjustments of the Torquay auto-equipment were checked and, in some cases, altered within existing adjustment limits. No trouble was, therefore, experienced with signalling or with dialling into the Torquay multi-office area, and transmission was good. Volume was a little below normal, but this was adequately offset by very good quality. Two transmission complaints were received, one of which was traced to a faulty trunk connection between Torquay and Derby, and the other to a faulty inset transmitter on the show ground.

From a technical aspect, what may be regarded as a field trial of busy local lines working to extended limits up to nearly 1,000 ohms line loop resistance for 14 days, was very successful indeed. Considerable information and experience has been gained with the problems and difficulties associated with long lines, which will be dealt with in a paper to be read in the South Western Region later.

Midland Region

B.I.F. DISPLAY

Each year since 1947, a display has been designed and staged on part of the space forming the Post Office, at the Birmingham section of the British Industries Fair. This year this display aimed at showing the public in a pictorial way how radiations emanating from car ignition systems cause interference to television reception, and how by the use of suppressors the trouble can be remedied in a simple manner.

The centre piece of the display was in effect a frame in which were mounted two enlarged photographs separated from each other by a symbolic brick wall in translucent perspex. The photograph on the left showed a car travelling along a road and the one on the right an indoor scene with a family group watching a television screen. The screen in the photograph was cut away and an actual working television set inserted in its place.

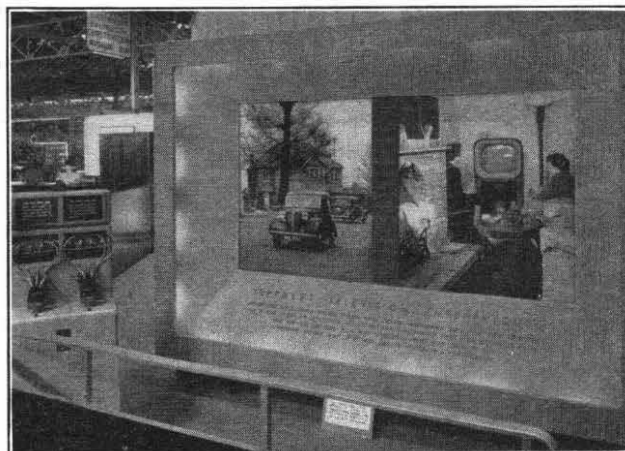

DISPLAY OF TELEVISION INTERFERENCE SUPPRESSION AT BRITISH INDUSTRIES FAIR.

The second part of the display mounted in front and to the right of the frame consisted of a unit on which were mounted two sets of sparking plugs and distributors. One set was fitted with suppressors and the other left unsuppressed.

By the use of interacting relays, each distributor and set of plugs was in turn caused to spark for a short duration. Interference was conducted from the unsuppressed set of plugs into the television receiver, with the result that the actual received television picture on show to the public, was, for alternate periods, marred by ignition interference. To demonstrate the source of the interference, spots of light in concentric circles were caused to radiate outwards from the car in ever-increasing size so as to appear to go through the brick dividing wall and encompass the television set within the room every time the interfering plugs were in operation.

The spots of light were produced by means of 6V switch-board-type lamps mounted behind the photographs. The surface of the photographs was treated so that they were

slightly translucent, with the effect that the lamps were only seen when illuminated.

This job was a good example of co-ordinated effort. The display was designed in the R.D.O.; the photographs were taken, enlarged, treated and mounted by the E.-in-C.'s Photographic Section; the construction of the framework, the wiring of the lamps and assembly was undertaken by the Birmingham Factory; while the lettering, the mounting of the television set, the erection of an aerial and the stand wiring was the work of the T.M.O., Birmingham.

Other Regions who might be interested in staging this display are invited to seek further details from the Regional P.R.O., Midland Region.
A. H. E.

TELEGRAPH POLE DATED 1870

One of the original poles purchased by the Post Office in 1870 when the Telegraph Service was nationalised is still standing on the Warwick-Stratford-upon-Avon route at a point two miles south of Warwick near the junction of the road to Barford. These poles are mentioned in the I.P.O.E.E. printed paper No. 154, written by Mr. Brent, who described them as monuments to the engineer who made the decision that creosote and not copper sulphate should be employed for preserving the timber.

The pole referred to is marked 7 ft. above the ground line with a crown, the letters G.P.O. and the date 1870. It is numbered 45 on an oval zinc label and also bears the pole-tester's G.49 label. It appears to be a 28-ft. medium pole and is in a good condition; the surface is covered with patches of hardened creosote up to the G.P.O. mark and at points 2 ft. and 9 ft. above the ground line there are patches of compound, apparently provided to seal damaged portions. The pole carries seven 4-way arms and 26 heavy-gauge wires; it is earth-wired on the surface of the timber and there are no steps.

Members of the local staff remember that in 1912 the route carried a square of four wires and cap wire; the latter was the Warwick-Barford-Norton Lindsay A.B.C. telegraph circuit which was recovered in 1913 by a 21-man gang operating on foot from Warwick.

At the time of the 1912 inventory the Warwick lineman was sent out to verify the date on this pole, which, even then, was regarded as unusual. The pole came to notice again in 1938 when the Engineer-in-Chief's Office asked for test borings to be taken below ground level. For a time these tests were made at six-monthly intervals and the borings were in perfect condition and black throughout.

In order to continue observation on the pole, should that section of the route ever be recovered, the pole will be immediately tested and re-erected in another working route. By this means it is hoped to preserve the pole carrying a load for at least a century.

This is the oldest dated pole in the Coventry Area, and it would be interesting to know if similar poles are still standing in other parts of the country.
H. H.

Northern Ireland Region

LIGHTING IN THE PUBLIC OFFICE, H.P.O., BELFAST

The lighting of a large Public Office usually involves the consideration of various factors which are not normally met in the more general type of lighting installation, e.g., the level of illumination required for counter work, the lighting of the public part of the office and the general aesthetic problem. The new Public Office, Head Post Office, Belfast, officially opened by the Assistant Postmaster General on 25th July, proved no exception to the rule and the solution of this particular case may be of interest to all concerned with the design of similar installations.

The office is a reconstructed part of the main building, or perhaps it could more aptly be described as a reconditioned part of the main building, and as such it presented a more difficult lighting problem than is likely to be experienced in an entirely new building. The room, which is rectangular, 87 ft. x 50 ft., has an approximate height of 33 ft. to the ceiling. The ceiling could hardly be considered an architectural feature and the whole of the appearance of the room prior to reconstruction was austere. The office is in the class "Temporary Public Office"

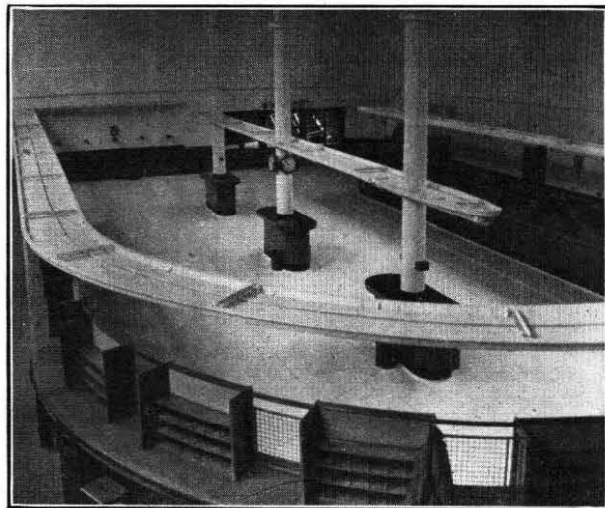

Photo by courtesy of "Belfast Telegraph."

VIEW SHOWING THE SUSPENDED CANOPIES OVER COUNTERS AND WRITING DESKS.

and it was not considered feasible on economic grounds to provide a new artificial ceiling.

It was the wish of the Senior Architect, Ministry of Finance, T. F. O. Ripplingham, Esq., A.R.I.B.A., that the electric lighting scheme should be so designed that a minimum of light should reach the ceiling and any feature that would tend to take the eye to the ceiling should be avoided. In effect, the object should be to "hide" the ceiling.

The problem was also aggravated by the fact that the natural lighting of the room was restricted to windows on each side of the room; on one side the windows being 15 ft. above floor level and on the other side 21 ft., and by the further complication that heating panels had a "right of way" on all four walls of the room at a height of 9 ft. 6 in. to 12 ft. 6 in.

Lastly, it was appreciated that artificial lighting was likely to be used more than would be considered normal in a Public Office and following discussions with the Engineering Department, Power Branch, it was decided that a fluorescent lighting scheme would probably offer the best solution.

The arrangement finally agreed upon was the provision of a suspended canopy, over the Public Counter, on which the fluorescent fittings would be mounted. A canopy was also necessary over the public writing positions situated between the arms of the "U"-shaped counter. The canopies are suspended from the ceiling by plated steel drop wires and consist of a 3/8-in. plywood base in a shaped and grooved framing. The canopies are decorated to match the walls and give a satisfactory reflecting surface. Over the counter a continuous line

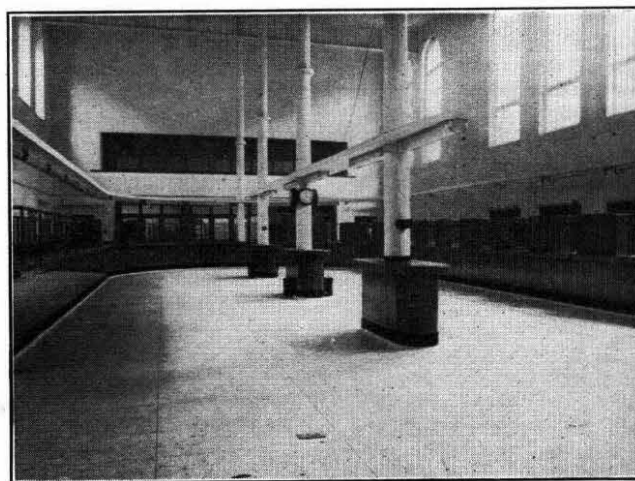

Photo by courtesy of Belfast News-Letter Ltd.

GENERAL VIEW OF PUBLIC OFFICE H.P.O. BELFAST.

of 5-ft. 80-W lamps is provided in single fittings with a clear "Perspex" reeded trough and the fittings are mounted directly on the canopy. On the central canopy the twin 5-ft. 80-W lamps are provided in fittings to match.

Because the Public Counter is "U"-shaped it was necessary to provide additional lamps in the corners of the office, but in general the whole of the lighting for the office is provided from the light canopy.

All the necessary conduit work is carried above the canopies and is concealed; access to the top of the canopies for the conduit run is obtained from the positions where the canopies are returned to the walls and continued over the writing positions. The design of the canopies and the suspension system is such that an adequate factor of safety is provided for maintenance personnel; in fact, access for maintenance purposes is probably more satisfactory than with any other possible arrangement.

The general effect is most pleasing and so far has met with the approval of the staff and the public. The scheme has satisfactorily solved the problems involved and may be considered an architectural feature of the office.

The installation was carried out by direct labour by the Telephone Manager, Belfast.
H. F.

Scotland

PROVISION OF TELEPHONE SERVICE AT ROYAL HIGHLAND SHOW, KELSO, 1952

The Royal Highland Show, the largest agricultural show held in Scotland, presents a problem to the town chosen as the venue, even when one of the larger towns or cities is selected. This year the site chosen was a triangular piece of land, entirely undeveloped, at the confluence of the rivers Tweed and Teviot, some 400 yards from the centre of Kelso, a typical county town of a farming community. Kelso itself is situated about 20 miles from Galashiels, its Group Centre, and about 50 miles from Edinburgh, its Zone Centre, and consequently was badly situated, so far as telephone plant was concerned, to cater for such an event as the "Highland."

The telephone equipment at Kelso exchange consists of four C.B.S. No. 2 positions which could not handle the additional traffic anticipated during the duration of the show, and which, for lack of space, could not be extended. The problem was further complicated by the fact that the buildings being erected on the show ground would not be ready for occupation until a few days before the commencement of the show. Alternatives then considered were a mobile automatic exchange of the No. 13 type held in the Edinburgh Area, and a 5-position C.B.S. No. 2 exchange awaiting installation at Coldstream, some 20 miles from Kelso. On a basis of cost and traffic handling capacity, a decision in favour of the manual type of installation was made, and temporary premises for the switchboards obtained in a hall in Kelso overlooking the show ground. These premises were leased for a period of six weeks, allowing four for installation, one for operation and one for recovery. The shortness of the installation period was overcome by pre-fabrication of the subscribers' and junction multiples, the answering equipment, and the complete wiring and testing of the positions themselves in Edinburgh before their movement to site. The quantity and layout of equipment for the Show exchange was as far as possible the same as that for the Coldstream exchange, where the switchboards would ultimately go into service, and cables were left with sufficient length to permit their retermination later.

The line plant position was, if anything, a more serious problem than that of exchange equipment. A total of some 40 circuits was required from Kelso to Galashiels, the Group Centre, but only six underground pairs were immediately available. Other outlets to the North Eastern Region were sought but were not of much assistance in meeting the demand, which was for routes to Glasgow, Edinburgh and the North of Scotland. The suggestion was made that carrier equipment of the type used by the Army Signals might prove a solution and this was investigated. As a result, 14-channel equipment, known as "Apparatus Selective Carrier," using frequencies from 50-386 kc/s and employing both side-bands, was made available and tested on two overhead routes which were partly existing and partly specially provided for the occasion. These tests were considered satisfactory and equipment for two

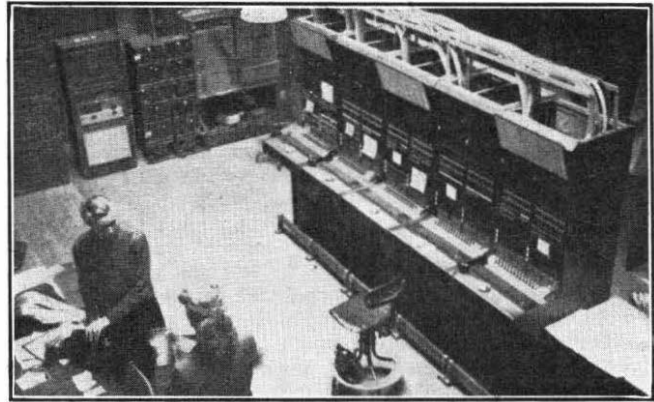

THE KELSO SHOW EXCHANGE WITH CARRIER EQUIPMENT IN THE REAR.

complete systems (28 channels in all) was borrowed from the Army authorities, and provided, one between Galashiels and Kelso Show exchange, and one between Melrose and Kelso Show exchange, the overhead circuits concerned being differently routed in order to avoid interference between the two systems. Those circuits terminating at Melrose were extended the remaining five miles to Galashiels on physical pairs in a new cable which was in course of provision, but whose completion and balancing was accelerated for the show. In addition, two complete sets of Army type 1 + 4-channel carrier equipment were lent to the Area, and were set up on the same circuits as the 14-channel equipment.

A view of the equipment at the temporary premises at Kelso is shown on the photograph, where the carrier equipment may be seen in the background.

The exchange served a total of 92 subscribers and 26 call offices, and handled over 9,000 calls during the four-day duration of the show. In addition to the 30 circuits routed via the carrier equipment, 35 additional junctions were provided to exchanges within 30 miles radius of the show ground, an additional 17 provided between Galashiels and Edinburgh, the Zone Centre, and a further six operating on a 2-V.F. basis provided to augment the Glasgow-Edinburgh inter-zone route.

W. T. W.

INTRODUCTION OF SIGNALLING SYSTEM A.C. NO. 5X

The rapid increase which has taken place in the generation of hydro-electricity in Scotland in the past few years has led to the appearance of E.H.T. power transmission lines in many of the highland glens and cases of parallelism between power and telephone lines have become common.* Up to the present time, when protection of Post Office lines from the inductive effect of power surges has been necessary, it has been given by means of gas discharge tubes fitted to the lines at their ends and at various points on the route. A power line, nearing completion, which will link the Tummel Area and Loch Sloy hydro-electric schemes, will submit parallel Post Office lines to an exposure so severe that the provision of gas discharge tubes would be extremely costly owing to the number of points at which they would have to be fitted and the expense of providing an adequate earth connection, in soil of high resistivity, at each of these points.

In the worst cases of exposure, therefore, it has been decided to adopt the alternative of breaking the Post Office lines, by means of isolating transformers, into sections of such a length that the induced voltage in any section will not exceed the permissible safety figure under the worst conditions of power faults. Unfortunately, this debars the employment of D.C. signalling or loop-disconnect dialling over the affected lines, and to meet this condition special equipment employing a system of pulse signalling has been developed in the E.-in-C.'s Office and given the name Signalling System A.C. No. 5X.

A new U.A.X. No. 12 at Lawers in the Dundee Telephone Area, equipped with the A.C. No. 5X signalling on its junctions to the parent exchange, Killin U.A.X. No. 13, was opened on

* See p. 104 of this issue.

14th August, 1952. In the near future similar equipment will be provided for the Killin-Luib (dependent U.A.X. No. 12), Killin-Crianlarich (non-dependent U.A.X. No. 12) and Glenfalloch-Arrochar junctions.

Briefly, bothway dialling and signalling is by means of short bursts of 50 cycles per second. To simplify the equipment and to ease the task of the maintenance man, the normal U.A.X. junction facilities of Trunk Offering, Busy Flash and Coin Box discrimination have been omitted.

Pulsing current is obtained from the mains supply via a power unit with an output of 40V at 50 c/s. A standby battery-operated vibrator is provided.

Impulse regenerators are incorporated in the equipment at both ends of the junctions primarily to make good the loss of the intertrain pause, caused by the transmission of seizure pulses in between two digits of an outgoing route code, but advantage is taken of their existence to correct impulse distortion of incoming calls.

The experimental equipment at Lawers U.A.X. No. 12 is accommodated in a Unit Auto 12A gutted of normal apparatus and at Killin U.A.X. No. 13 an additional Unit Auto No. 13B has been installed. For the sake of the impulse regenerators, these units have been fitted internally with tubular heaters.

J. B. D

T.V. INTERFERENCE—CORONA DISCHARGE

August is generally considered a fairly quiet month for interference cases, so the incidence of nearly 20 cases over a space of two days, each having the same story to tell, from the Downfield district of Dundee, pointed to the existence of a

very potent source of interference. In fact, its effect was later found to extend over an area of about half a mile in diameter.

The initial investigation pointed to an overhead E.H.T. line (132 kV) which threads this area, and subsequent testing led to the source—a short piece of wire hanging from a lower conductor approximately in the middle of a span. From beneath the wire the characteristic sound of corona discharge was evident enough, as also was the more irregular arcing sound of the corona current passing between the conductor and the wire. It is interesting to note that, although this line is flanked by houses, no case of medium-wave or long-wave broadcast interference was reported. Tests proved that no appreciable interference level existed at these frequencies outside a radius of 10 yards from the source.

The piece of wire was recovered two days later by the North of Scotland Hydro-Electric Board authorities. The wire was found to be a length of $\frac{1}{8}$ -in. diameter bicycle brake cable of the Bowden type, complete with the threaded brass connecting piece at one end. Its point of contact with the line conductor, evident by a bluish mark, was 11 in. from one end; its overall length being 43 in. This last-mentioned characteristic of the wire is thought significant, since its electrical length considered as a quarter wavelength would render it ideal for radiating frequencies in the region of those employed for the Kirk O'Shotts transmission.

After being told of the nature of the source of the trouble, the complainants were rather sceptical of the idea of such a spiritless thing as a small piece of wire causing such a fuss. Perhaps in this modern age small boys are turning away from the old-fashioned pranks, such as knocking at doors and decamping, to more scientific methods of creating mischief. F. R. R.

Book Review

"The Calculation of Unsymmetrical Short Circuits." H. Rissik, B.Sc.(Eng.), M.Amer.I.E.E. Revised by W. F. Lovering, M.Sc., A.M.I.E.E. Pitman. 54 pp. 22 ill. 12s. 6d.

This book of 54 pages is an introduction to the method of symmetrical components for the solution of fault current problems in A.C. power networks. The method was suggested by Stokvis in 1914 and developed by Fortescue and others. The three vectors of phase current, which are obviously unsymmetrical when a fault exists on one phase of a 3-phase system, can be replaced by three symmetrical vectorsystems, one having the same phase rotation as the original, one with negative rotation and one with zero phase sequence, i.e. with the three current vectors coincident both in angle and magnitude revolving in the positive direction. The theorem is very useful, as the alternative of using Kirchoff's Laws is clumsy and laborious, particularly when complex interconnected systems are involved. The proof of the theorem is not given in this book. The five short chapters deal with fundamentals, symmetrical impedance equivalents of unsymmetrical faults, phase sequence impedances of a power network, the application of the method to a specific example and fault current distribution.

The book should be of value to those whose knowledge of vector algebra is insufficient to follow the more extensive treatises on this subject, but who nevertheless wish to know something of modern methods of network calculations. A. E. P.

SHORTER NOTICES

"NATIONAL PHYSICAL LABORATORY REPORT FOR THE YEARS 1940-1945." H.M. Stationery Office. 159 pp. 5s.

A composite Report covering the war years, prepared to fill the gap in the published Reports of the Laboratory. The Report describes the scientific investigations undertaken for the Service Departments and others during this period.

"NATIONAL PHYSICAL LABORATORY REPORT FOR THE YEAR 1951." H.M. Stationery Office. 77 pp. 3s.

This publication includes the Report of the Executive Committee on the work of the Laboratory during 1951 and

accounts of the activities of 11 Laboratory Divisions covering Aerodynamics, Electricity, Engineering, Light, Mathematics, Metallurgy, Metrology, Physics, Radio, Ships and Electronics.

"CURRENTS AND FIELDS IN ELECTRICAL ENGINEERING." H. E. M. Barlow. H. K. Lewis & Co., Ltd., London. 20 pp. 5 ill. 5s.

An Inaugural Lecture delivered at Univeristy College, London, on 21st November, 1950, by the Pender Professor of Engineering in the University of London.

"EXTENSION AND DISSEMINATION OF THE ELECTRICAL AND MAGNETIC UNITS BY THE NATIONAL BUREAU OF STANDARDS." National Bureau of Standards Circular No. 531. Francis B. Silsbee. U.S. Government Printing Office, Washington D.C. 33 pp. 27 ill. 25 cents.

This circular gives an overall picture of the sequence of measuring processes by which a self-consistent system of electrical units is built up in the Laboratories of the Bureau and thence disseminated throughout the country.

"MEASUREMENT OF THE THICKNESS OF CAPACITOR PAPER." National Bureau of Standards Circular No. 532. Wilmer Souder and Sanford B. Newman. U.S. Government Printing Office, Washington D.C. 10 pp. 6 ill. 15 cents.

This circular describes and analyses measurements made at the N.B.S. on some commercial thin capacitor papers by means of the interferometer, micrometer microscope, mechanical micrometer, and surface analyser.

"ELECTRONIC APPLICATIONS." Henry A. Miller, A.M.I.E.E. E. & F. Spon, Ltd. 110 pp. 48 ill. 21 plates. 18s.

A book for the non-technical reader giving a very brief account of some of the present-day electronic applications.

"THE PRACTICAL ELECTRICAL REFERENCE BOOK." Odhams Press, Ltd. 383 pp. 316 ill. 9s. 6d.

This book is arranged in 36 self-contained sections each covering a separate field of application e.g. Wiring, Refrigeration, Electric cranes, etc. More than 20 authors have contributed the various sections which contain compact summaries of the subject matter, tables and formulæ useful to electrical engineers and students.

Staff Changes

Promotions

Name	Region	Date	Name	Region	Date
<i>Area Engr. to Regl. Engr.</i>			<i>Tech. I to Inspector</i>		
Mellor, S. D.	N.E. Reg. to N.W. Reg.	13.7.52	Dew, W. S.	E.-in-C.O.	18.8.52
<i>Area Engr. to Deputy T.M.</i>			<i>Mech. I/C I to Tech. Asst. II</i>		
Hickox, W. F.	L.T. Reg.	18.8.52	Brownie, C. B. W.	S.W. Reg.	14.6.52
<i>Exec. Engr. to Snr. Exec. Engr.</i>			Smithson, J. K.	S.W. Reg.	14.6.52
Williams, M. B.	E.-in-C.O.	27.3.52	Weston, J.	W.B.C. Reg.	14.6.52
Redington, F. D.	E.-in-C.O.	11.7.52	<i>Mech. I/C II to Tech. Asst. II</i>		
<i>Inspector to Asst. Engr.</i>			Girling, G. R.	S.W. Reg. to Scot.	19.7.52
Clark, L.	N.E. Reg. to E.-in-C.O.	7.6.52	<i>Snr. Mech. to Tech. Asst. II</i>		
<i>Tech. Offr. to Asst. Engr.</i>			Watson, H.	N.E. Reg.	12.7.52
Seabridge, G. E.	Mid. Reg. to E.-in-C.O.	7.6.52	<i>Asst. Exper. Offr. to Exper. Offr.</i>		
Tye, L. E.	Mid. Reg. to E.-in-C.O.	7.6.52	Feasey, R. J.	E.-in-C.O.	3.6.52
Hood, J. W.	L.T. Reg. to E.-in-C.O.	7.6.52	<i>Snr. D'man to Chief D'man.</i>		
Wooding, R. S. G.	E.-in-C.O.	7.5.52	Benstead, E. C.	E.-in-C.O.	30.7.52
Purver, H. J.	E.-in-C.O.	13.6.52	<i>D'man. Cl. I to Asst. Tfc. Supt.</i>		
Woollard, H. L.	E.-in-C.O.	18.6.52	Edwards, P. W.	E.-in-C.O. to H.C. Reg.	17.3.52
Rodger, W. S.	E.-in-C.O.	7.6.52			
Nash, L. C.	E.-in-C.O.	12.7.52			
Clarke, E.	E.-in-C.O.	9.8.52			

Transfers

Name	Region	Date	Name	Region	Date
<i>Snr. Exec. Engr.</i>			<i>Asst. Engr.—continued.</i>		
Cooper, W. H. B.	E.-in-C.O. to Min. of Supply	13.6.52	Hamel, D. P. M.	E.-in-C.O. to N.E. Reg.	19.6.52
<i>Exec. Engr.</i>			Axford, C. J.	E.-in-C.O. to H.C. Reg.	21.7.52
Hix, K. W.	H.C. Reg. to P.M.G.s Dept., Australia	21.5.52	Perkins, W. T.	E.-in-C.O. to Admiralty	9.6.52
Male, H. H. R.	E.-in-C.O. to N.I. Reg.	1.8.52	<i>Snr. D'man.</i>		
<i>Asst. Engr.</i>			Martin, T.	E.-in-C.O. to L.T. Reg.	4.5.52
Smith, R. G. T.	E.-in-C.O. to H.C. Reg.	23.6.52	<i>D'man.</i>		
			Horridge, J. W.	E.-in-C.O. to Admiralty	1.7.52

Retirements

Name	Region	Date	Name	Region	Date
<i>Area Engr.</i>			<i>Inspector</i>		
Skeet, T. S.	Mid. Reg.	21.7.52	Barnes, T.	L.T. Reg.	26.6.52
<i>Snr. Exec. Engr.</i>			Billings, H.	N.W. Reg.	9.7.52
Judd, F. J.	E.-in-C.O.	10.7.52	Hall, W.	N.W. Reg.	3.6.52
Vernon, R. J.	E.-in-C.O.	31.7.52	Leslie, J.	Scot.	31.5.52
<i>Exec. Engr.</i>			<i>Tech. Asst. II</i>		
Kibble, R.	N.W. Reg.	31.7.52	Strachan, P. G. W.	E.-in-C.O. (Resigned)	30.6.52
Keown, W. S.	N.I. Reg.	1.8.52	<i>Asst. (Scientific)</i>		
Walker, W. T.	E.-in-C.O. (Resigned)	11.8.52	Harris, A.	E.-in-C.O. (Resigned)	14.8.52
<i>Asst. Engr.</i>			<i>D'man.-in-Training</i>		
Stone, C. H.	L.T. Reg.	10.7.52	Romaine, S. I.	E.-in-C.O. (Resigned)	12.2.52
Wilson, W. A.	W.B.C. Reg.	5.6.52	Clark, R. T. J.	E.-in-C.O. (Resigned)	12.12.51
Ade, A. F.	Mid. Reg.	1.6.52	<i>Exec. Offr.</i>		
Lees, W.	Scot.	30.6.52	Froom, C.	E.-in-C.O.	27.8.52
Callon, E.	E.-in-C.O.	13.8.52			
Norman, A. E.	L.T. Reg.	12.8.52			
Hunter, A. S.	Scot.	15.8.52			
McLeod, N.	Scot.	22.8.52			

Deaths

Name	Region	Date	Name	Region	Date
<i>Exec. Engr.</i>			<i>Asst. Engr.—continued.</i>		
Osborne, W. V.	E.-in-C.O.	19.6.52	Stone, W. C.	H.C. Reg.	24.7.52
Waterman, W. R.	L.T. Reg.	18.7.52	<i>Inspector</i>		
<i>Asst. Engr.</i>			Hatcher, W. E.	S.W. Reg.	3.6.52
Tait, J. M. (Senior)	Scot.	9.6.52	Williams, H.	N.E. Reg.	2.7.52
Fytche, W. H.	E.-in-C.O.	28.6.52	Morton, A. S.	Scot.	13.7.52

ASSOCIATE SECTION NOTES (continued from p. 136)

The lecture, in November, entitled "Producing a Newspaper," is to be given by a member of the staff of The Birmingham Gazette & Despatch, Ltd., and will be followed a week later by an evening visit to Newspaper House, the works of this firm, to enable members to see just how their newspaper is produced. A visit to Messrs. Mitchells & Butlers' Cape Hill Brewery has been arranged for early December, and the talk that month will be a repeat of an extremely popular one given last Session by Mr. G. W. Jones of E.M.I. Sales & Service, Ltd., on the subject "Servicing Television Receivers."

The Officers and Committee are now waiting to see whether the increase in the number of members (140 to 189) since the A.G.M. in April will be reflected in the attendance at forthcoming meetings. In the next notes it is hoped to report on some of the events mentioned above and also to give notice of meetings and visits to be held between January and April, 1953.

K. G. S. A.

Aberdeen Centre

The 1951/52 Session was a very successful one with a membership of 110 and a total of six papers read to the Centre. The following were elected office-bearers for 1952/53:—

President, H. J. Revell, B.Sc., Area Engineer; *Chairman*, J. D. Thomson; *Vice-Chairman*, D. S. C. Buchan; *Secretary and Treasurer*, J. H. Lawrence; *Librarian*, J. T. Pike; *Auditors*, D. D. Milne and R. W. Lord. *Committee*, Messrs. J. L. MacLachlan, G. C. McKee, F. L. Crabbe, R. T. Ross, J. Yule, J. T. Pike.

Programme, 1952/53:—

October.—"Telecommunications in Greece," J. Knox, M.Sc., A.M.I.E.E., Area Engineer, Dundee.

November.—"The Traffic Side," P. Docharty, A.T.S., Aberdeen.

December.—"The P.A.B.X. No. 1," J. H. Lawrence, T/O Aberdeen.

January.—"Introduction to Mechanical Engineering," R. T. Ross, T/O Aberdeen.

February.—"The Present System of Appraisal and Promotion," Col. Calveley, O.B.E., B.Sc., M.I.E.E.

March.—A.G.M., plus film.

We have ample accommodation at the Aberdeen Centre, so come along and support us by your presence. J. H. L.

London Centre

The London Centre held their Annual-General Meeting on the 28th May, 1952, at Waterloo Bridge House. Among the 150 Members present were many ex-committee members, who had been invited to this A.G.M., the 20th anniversary of the London Centre.

The election of Officers was first conducted. Addresses were then given by Col. C. E. Calveley, the President of the Associate Section, and Mr. F. C. G. Greening, the London Centre Liaison Officer, followed by a paper, "The R.C.O.S. and the Invasion of Europe," read by Col. C. E. Calveley. The paper prompted many questions and reminiscences, for it was apparent that many members present had been associated with the schemes that the President referred to in his lecture.

The committee and members of the London Centre would like to extend their thanks to the Senior Section Council and the members of the Liaison Officers' Conference, for the legislation in the changing of our title from Junior to Associate Section.

At the A.G.M. the following officers were elected:—

Chairman, A. G. Welling; *Vice-Chairman*, A. W. Britton; *General Secretary*, P. Sayers; *Assistant Secretary*, W. J. Black; *Treasurer*, W. C. Peck; *Librarian*, W. P. Skinner; *Visit Secretary*, B. C. Hatch; *Radio Secretary*, H. E. Warren.

Mr. F. C. G. Greening had indicated that he would be the Liaison Officer for the coming Session.

The lecture programme for the 1952/53 Session was arranged, and begins in October with a paper read by an Associate Member, Mr. B. G. Woods, on "Call Queueing on Sleeve Control Switchboards." This will be followed in November by a paper read by another Associate Member, Mr. A. W. Haddow, of Cable & Wireless, on the "Automatic Teleprinter Concentrator."

A. G. W.

BOARD OF EDITORS

H. FAULKNER, C.M.G., B.Sc., M.I.E.E., Chairman.
W. WEST, B.A., M.I.E.E.
Capt. C. F. BOOTH, O.B.E., M.I.E.E.
L. F. SCANTLEBURY, Whit.Sch., A.C.G.I., D.I.C., A.M.I.E.E.
D. A. BARRON, M.Sc., A.M.I.E.E.
E. DAVIS, A.M.I.E.E.
L. CHANT.
G. E. STYLES, A.M.I.E.E., Managing Editor.
W. A. HUMPHRIES, A.M.I.E.E.
J. P. HARDING, B.Sc.(ENG.).
A.M.INST.C.E., A.M.I.E.E. } Assistant Editors.
A. J. HUTCHISON, Secretary-Treasurer.

Copyright

The entire contents of this JOURNAL are covered by general copyright, and special permission is necessary for reprinting long extracts, but Editors are welcome to use not more than one-third of any article, provided credit is given at the beginning or end thus: "From the *Post Office Electrical Engineers' Journal*."

The Board of Editors is not responsible for the statements made or the opinions expressed in any of the articles in this JOURNAL, unless such statement is made specifically by the Board.

Communications

All communications should be addressed to the Managing Editor, *P.O.E.E. Journal*, Engineer-in-Chief's Office, Alder House, Aldersgate Street, London, E.C.1. Telephone: HEADquarters 1234. Remittances should be made payable to "The *P.O.E.E. Journal*" and should be crossed "& Co."

Binding Cases

Cases for binding are available, and may be obtained from the Local Agents for 3s. Subscribers can have their copies of volumes bound, at a cost of 10s. 6d., by sending the complete set of parts to the Local Agents or to the *P.O.E.E. Journal*, Engineer-in-Chief's Office, Alder House, Aldersgate Street, London, E.C.1. Orders for binding for Vols. 1-19 should indicate whether the original binding case with black lettering, or the later pattern with gold, is required. Cases with gold lettering are the only type stocked from Vol. 20 onwards.

Back Numbers

The price of the JOURNAL, which is published quarterly, is 2s. 6d. (2s. 9d. post free) per copy, or 1 ls. per annum, post free. Back numbers can be supplied, subject to availability of stocks, at 2s. 6d. each (2s. 9d. post free). Orders for back numbers may be sent to the *P.O.E.E. Journal*, Engineer-in-Chief's Office, Alder House, Aldersgate Street, London, E.C.1, or to the Publishers.

Employees of the British Post Office can obtain the *Journal* through Local Agents at the reduced price of 2s. per copy.

Advertisements

All communications relating to space reservations should be addressed to the Advertisement Editor, *P.O.E.E. Journal*, Alder House, Aldersgate Street, London, E.C.1. Communications regarding advertisement copy, proofs, etc., should be addressed to the Publishers, Messrs. Birch & Whittington (Prop. Dorling & Co. (Epsom), Ltd.), 49 Upper High Street, Epsom, Surrey.

PRINTED PAPERS

The following papers contributed to the proceedings of the Institution have been printed by the authority of the Council and may be obtained, if still in print, from "THE LIBRARIAN, THE INSTITUTION OF POST OFFICE ELECTRICAL ENGINEERS, G.P.O. (ALDER HOUSE), LONDON, E.C.1."

The price of each Paper is Is. 6d., plus postage, and in every case Members, Associate Members, and Associates have the privilege of purchasing copies at Is.

- No. 140. "SOME NON-METALLIC SUBSTANCES AND THEIR CHARACTERISTICS."—Capt. N. F. CAVE-BROWNE-CAVE B.Sc., A.M.I.E.E. 1931.
- †No. 146. "LAYING ARMoured CABLE BY MEANS OF A MOLE-DRAINER."—L. G. SEMPLE, B.Sc.(Eng.), and R. O. BOOCOCK, B.Sc.(Eng.). 1932.
- No. 148. "STORES SPECIFICATIONS AND ACCEPTANCE TESTING."—Capt. J. LEOP, B.Sc., A.M.I.E.E. 1933.
- †No. 163. "AUTOMATIC EXCHANGE DESIGN."—H. E. FRANCIS. 1936.
- †No. 164. "THE LONDON-BIRMINGHAM COAXIAL CABLE SYSTEM."—A. H. MUMFORD, B.Sc.(Eng.), A.M.I.E.E. 1937.
- †No. 165. "PROPERTIES AND TESTING OF DIELECTRIC MATERIALS."—J. F. DOUST and W. J. SULSTON, M.Sc., A.Inst.P. 1936.
- †No. 166. "CHEMISTRY AND COMMUNICATIONS."—D. W. GLOVER, M.Sc., A.I.C. 1937.
- †No. 169. "CROSSTALK."—H. C. S. HAYES, A.M.I.E.E., R. A. SEYMOUR and P. R. BRAY, M.Sc.(Eng.), Grad.I.E.E. 1938.
- No. 173. "AUDIO-FREQUENCY RIPPLE FROM D.C. POWER SUPPLIES IN COMMUNICATION ENGINEERING."—H. R. HARBOTTLE, B.Sc., D.F.H. M.I.E.E., J. A. SHEPPARD, B.Sc., A.M.I.E.E., and D. L. RICHARDS, B.Sc. 1939.
- No. 174. "METALLURGY AND COMMUNICATIONS."—E. V. WALKER, B.Sc., A.R.S.M. 1940.
- No. 177. "RECENT APPLICATIONS OF THE QUARTZ AND X-RAY SPECTROGRAPHS TO POST OFFICE PROBLEMS."—R. TAYLOR, M.A., Ph.D., B.Sc. 1941.
- No. 178. "LONG DISTANCE D.C. IMPULSING."—S. WELCH, M.Sc.(Eng.) and C. H. J. FLEETWOOD. 1942.
- No. 179. "INTRODUCTION OF U.A.X. MULTI-METERING IN THE LEEDS AREA."—H. G. COPE. 1941.
- †No. 182. "LONDON INLAND TRUNK SERVICES."—W. H. SCARBOROUGH, A.M.I.E.E. 1943.
- †No. 184. "THE FUNDAMENTALS OF DIRECT CURRENT IMPULSING IN MULTI-EXCHANGE AREAS."—S. WELCH, M.Sc.(Eng.), A.M.I.E.E. 1944.
- †No. 186. "TELEPHONE SERVICE OBSERVATIONS."—J. J. PERKINS, A.M.I.E.E. 1945.
- †No. 187. "CABLING PROBLEMS IN SUBWAYS AND TUNNELS."—T. G. TURLEY, A.M.I.E.E. 1945.
- †No. 189. "DEVELOPMENT OF TELEGRAPH SWITCHING IN GREAT BRITAIN."—J. A. S. MARTIN, A.M.I.E.E., and J. W. FREEBODY, Whit. Schol., B.Sc.(Eng.), D.I.C., A.M.I.E.E. 1944.
- †No. 190. "WIDEBAND TRANSMISSION OVER COAXIAL CABLES."—R. A. BROCKBANK, Ph.D., B.Sc., A.M.I.E.E., and C. F. FLOYD, M.A., A.M.I.E.E. 1946.
- †No. 191. "PIEZO-ELECTRIC QUARTZ AND ITS USE IN TELECOMMUNICATIONS."—G. F. BOOTH, M.I.E.E., and J. L. CREIGHTON, A.M.I.E.E. 1946.
- †No. 193. "IMPROVEMENTS IN TELEPHONE SIGNALLING."—S. WELCH, M.Sc.(Eng.), A.M.I.E.E., and C. H. J. FLEETWOOD, A.M.I.E.E. 1949.
- †No. 194. "MAINTENANCE OF MULTI-CHANNEL CARRIER TELEPHONE SYSTEMS."—F. O. MORRELL, B.Sc., A.M.I.E.E. 1948.
- †No. 195. "THE INTRODUCTION OF AUTOMATIC SWITCHING TO THE INLAND TELEPRINTER NETWORK."—H. E. WILCOCKSON, A.M.I.E.E., and C. W. A. MITCHELL, A.M.I.E.E. 1949.
- †No. 196. "WIRE BROADCASTING."—F. HOLLINGHURST, B.Sc.(Eng.), A.C.G.F.C., M.I.E.E., and W. PRICKEETT, A.M.I.E.E. 1949.
- †No. 197. "THE POSSIBILITIES OF SUPER-HIGH FREQUENCY RADIO AND WAVEGUIDE SYSTEMS FOR TELECOMMUNICATIONS."—W. J. BRAY, M.Sc.(Eng.), A.C.G.I., D.I.C., A.M.I.E.E. 1948.
- No. 198. "INTRODUCTION AND APPLICATION OF TRANSMISSION PERFORMANCE RATINGS TO SUBSCRIBERS' NETWORKS."—G. A. E. FUDGE, A.M.I.E.E. 1949.
- †No. 199. "SOME APPLICATIONS OF ELECTRONIC METHODS TO TELEGRAPH APPARATUS."—R. O. CARTER, M.Sc.(Eng.), A.M.I.E.E., and L. K. WHEELER, B.Sc.(Eng.), A.M.I.E.E. 1949.
- †No. 200. "TRENDS IN THE DESIGN OF LINE TRANSMISSION EQUIPMENT."—R. J. HALSEY, B.Sc.(Eng.), A.C.G.I., D.I.C., M.I.E.E. 1949.

† The Council have awarded Institution Medals for these papers.

INDEX TO ADVERTISERS

	PAGE
Airmec Laboratories, Ltd.	xxix
Alton Battery Co., Ltd., The	xi
Automatic Coil Winder & Electrical Equipment Co., Ltd.	xxiv
Automatic Telephone & Electric Co., Ltd.	xiv-xv, xviii-xix
Bennett College, The	ii
British Electric Resistance Co., Ltd., The	x
British Institute of Engineering Technology	ii
Creed & Co., Ltd.	xxi
Dexion, Ltd.	xxix
Dubilier Condenser Co. [1925], Ltd.	xiii
Edison Swan Electric Co., Ltd., The	xxx
E.M.I. Institutes	iii
Ericsson Telephones, Ltd.	vii
Evershed & Vignoles	iv
Ferranti, Ltd.	v
General Electric Co., Ltd., The	vxi-xvii
Great Northern Telegraph Co., Ltd.	xxv
Hackbridge Cable Co., Ltd.	xxv
Hivac Ltd.	viii
International Correspondence Schools, Ltd.	xxix
Jones, Walter, & Co. (Engineers), Ltd.	xxvii
Marconi Instruments, Ltd.	ix
Marconi's Wireless Telegraph Co., Ltd.	xii
Muirhead & Co., Ltd.	v
Mullard, Ltd.	ix
Painton of Northampton	vi
Pirelli-General Cable Works, Ltd.	xxx
Pitman, Sir Isaac, & Sons, Ltd.	viii
Savage Transformers	ii
Savage, W. Bryan, Ltd.	xxvii
Siemens Brothers & Co., Ltd.	xx
Smith, Frederick & Co.	ii
Standard Telephones & Cables Ltd.	xxii-xxiii
Sullivan, H. W. Ltd.	xxvi
Telephone Manufacturing Co., Ltd.	xxiv
Tungstone Products Ltd.	xxvii
Westinghouse Brake & Signal Co., Ltd.	xxvi
Winn & Coales, Ltd.	viii

FREE

THIS VALUABLE BOOK



which details the wide range of Engineering and Commercial courses of modern training offered by E.M.I. Institutes—the only Postal College which is part of a world-wide Industrial Organisation.

Courses include training for:

P.M.G. Certificates, City and Guilds Grouped Certificates in Telecommunications; A.M.Brit.I.R.E. Examination, Radio Amateur's Licence, Radio & Television Servicing Certificates, General Radio and Television Courses, Radar, Sound Recording, etc. Also Courses in all other branches of Engineering.

E.M.I.

Institutes

associated with

MARCONIPHONE

COLUMBIA

H.M.V.

(His Master's Voice)

ETC.

★

COURSES FROM

£1

PER MONTH

POST NOW

Please send, without obligation, the above FREE book. E.M.I. Institutes, Dept. 22, 43 Grove Park Road, London, W.4.

Subject(s) which interest me

Name

Address

IC 10c

Evershed Recorders

Evershed Recorders measure electrical quantities, such as current, pressure, power, frequency, power factor; mechanical quantities, such as speed or water-level; or plot automatically on a time basis a given operation, or a combination of an operation with a quantity record. Instruments can be supplied with 1, 2 or 3 movements in one case and recording simultaneously. They can be fitted with either spring-driven or electrically-driven clocks. Fixed or portable, they can save manpower by operating in any unattended position. Single or multi-pen, they will record one single operation or a number of operations for comparison.

Ask for Publication X.222. Also available are Evershed Operation Recorders which plot on a time basis the frequency and duration of any operation.

Single Pen or Multi-Pen Operation. Fully described in Publication X.248.

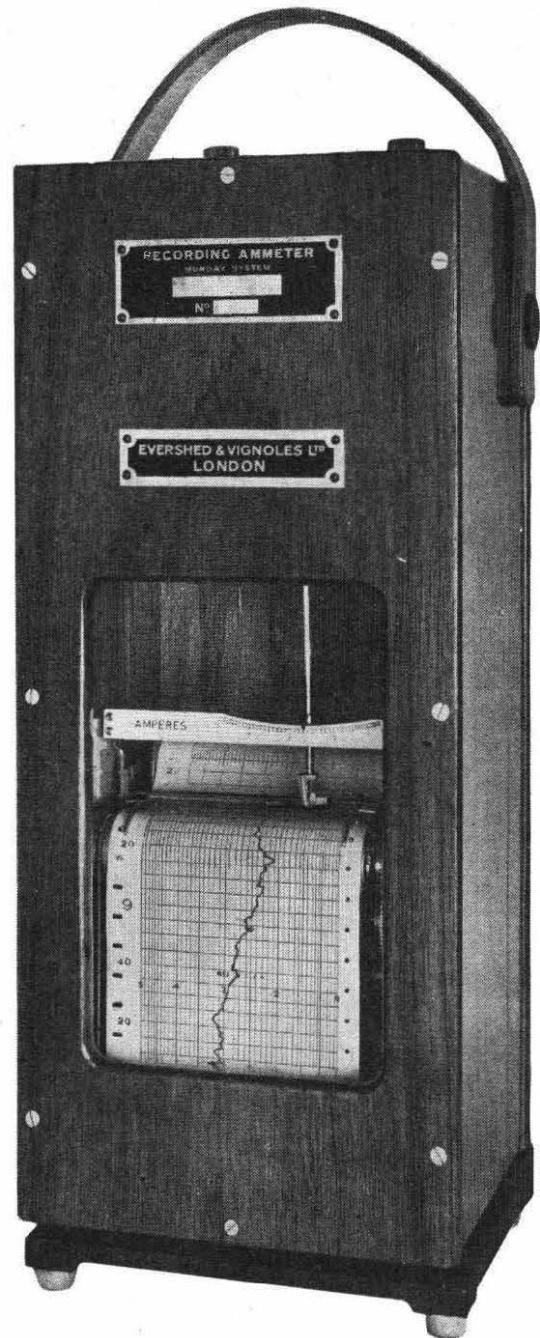

EVERSHED

PROCESS CONTROLLERS · REMOTE CONTROLLERS
INDICATORS AND RECORDERS · MEGGER TESTERS

EVERSHED & VIGNOLES LIMITED ACTON LANE WORKS, CHISWICK, LONDON, W.4

Telephone: Chiswick 3670. Telegrams: Megger, Chisk, London. Cables: Megger, London

FERRANTI

SWITCHBOARD INSTRUMENTS

SQUARE PATTERN FOR FLUSH MOUNTING
easy circular hole panel fixing

DIALS, 4", 6" and 8". Open or protected

TYPES Moving-coil and moving iron ammeters and voltmeters. Dynamometer wattmeters. Power Factor Meters. Induction wattmeters. Frequency Meters. Synchrosopes. Synchronous Clocks.
Round patterns, projecting or flush, also supplied in above sizes and types.

Write for descriptive lists.



FERRANTI LTD., HOLLINWOOD, LANCASHIRE, ENGLAND

London Office: KERN HOUSE, KINGSWAY, W.C.2



4 in. DYNAMOMETER
WATTMETER



6 in. FREQUENCY METER

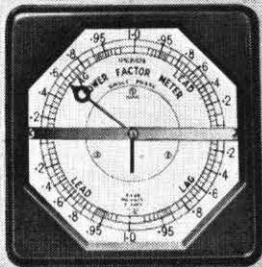

8 in. POWER FACTOR METER

F1100

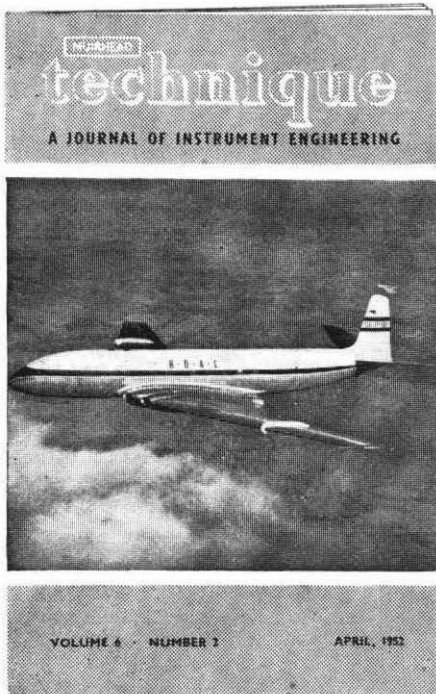

**THIS INTERESTING QUARTERLY
WILL BE MAILED *FREE*
TO ANY PART OF THE WORLD
POST THIS COUPON TODAY**

MUIRHEAD & CO. LTD · BECKENHAM · KENT · ENGLAND

Please mail me, free of charge, your quarterly journal "technique"

NAME _____

POSITION _____

COMPANY _____

ADDRESS _____

76

MUIRHEAD & CO. LTD · BECKENHAM · KENT · ENGLAND
PRECISION ELECTRICAL INSTRUMENT MAKERS



By Appointment to the Professional Engineer...

ATTENUATORS · FADERS · STUD SWITCHES AND TOGGLE SWITCHES
WIREWOUND POTENTIOMETERS · HIGH STABILITY CARBON RESISTORS
WIREWOUND RESISTORS · PLUGS AND SOCKETS · TERMINALS
KNOBS DIALS AND POINTERS

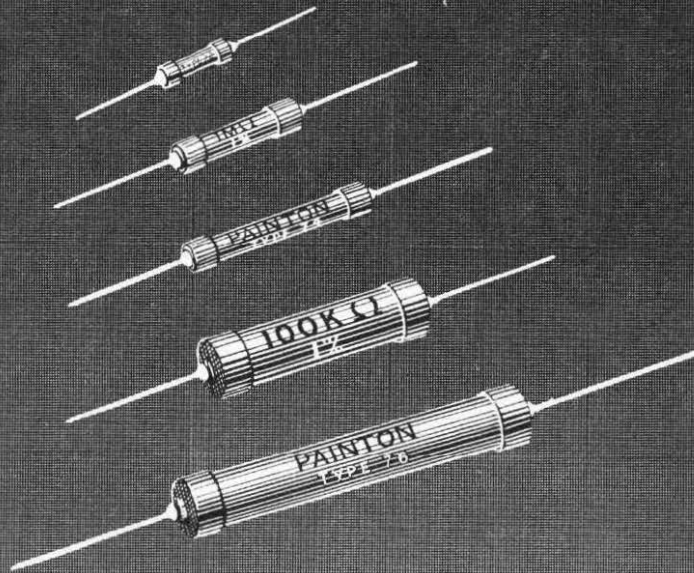

HIGH STABILITY CARBON RESISTORS

$\frac{1}{8}$ w, $\frac{1}{4}$ w, $\frac{1}{2}$ w, 1w and 2w types available at 1%, 2% or 5% Resistance Tolerance.
Complete range fully R.C.S.C. approved.

PAINTON
Northampton England

The 'DEKATRON'

A MULTI-ELECTRODE
COLD-CATHODE
COUNTING TUBE

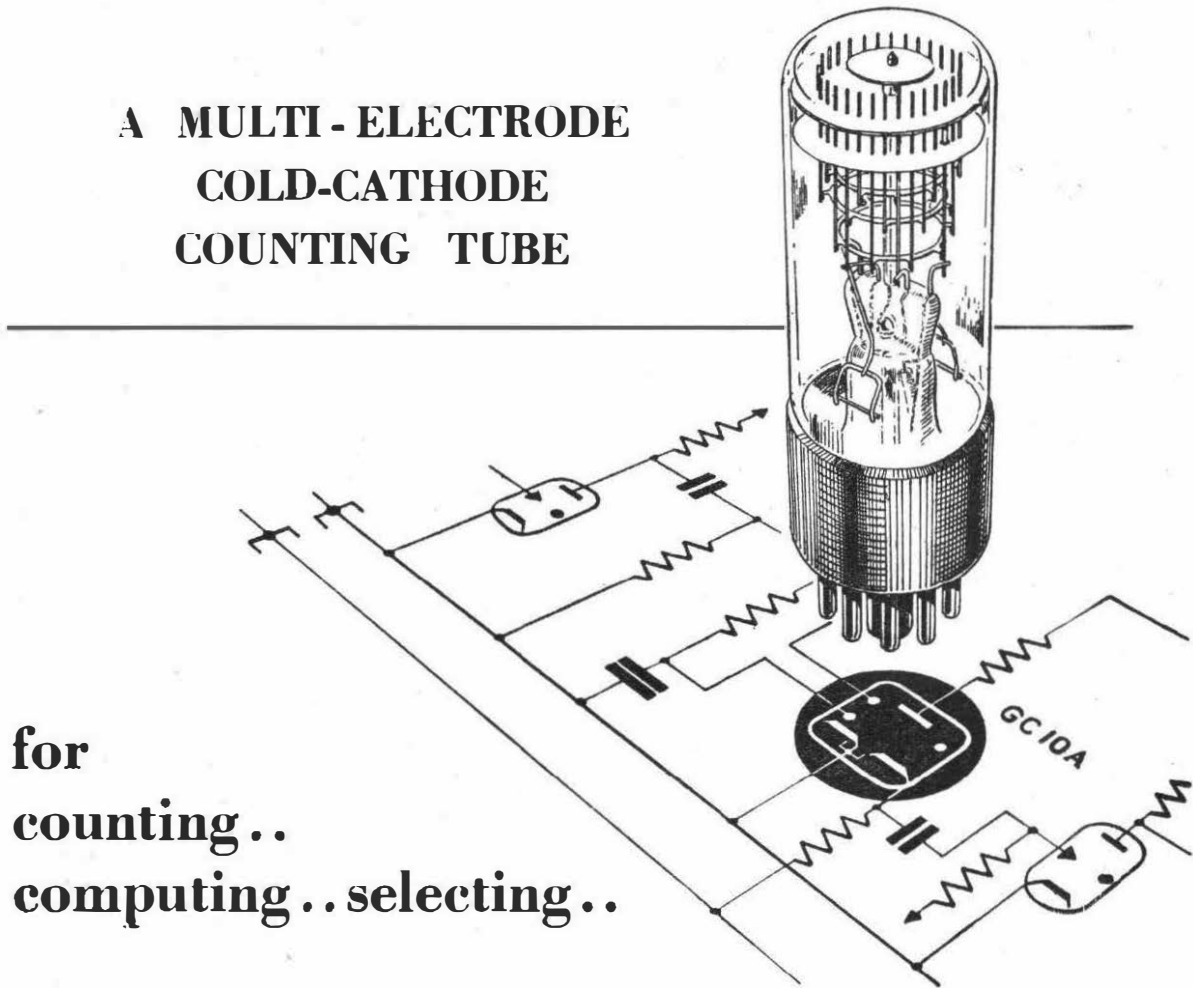

for
counting..
computing..selecting..

Ericsson

TELEPHONES LTD.

22 LINCOLN'S INN FIELDS, LONDON, W.C.2 · Tel. HOLborn 6936 · Works: BEESTON, NOTTS.

E5

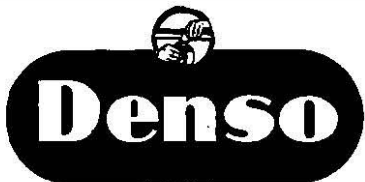

Denso Tape provides complete protection for pipes, mains, cables and all metalwork against the combined attacks of chemical and electrolytical corrosion. Permanently plastic — Denso forms a perfect gas- and water-tight seal that withstands the heaviest vibration. Ideal for temporary repairs — an aid to frost-proofing.

against CORROSION

Write for full details of Denso Anti-corrosive and Sealing Products without obligation, from:—

WINN & COALES LTD.
 DENSO HOUSE, CHAPEL ROAD, LONDON, S.E.27
 Telephone: GIPsy Hill 4247/8
 Telegrams: Denselta, Westnor, London

PITMAN

Telecommunications Principles

By R. N. Renton, M.A.I.E.E. A useful work covering the syllabus for the City and Guilds examinations in Telecommunications Principles, Grades I, II and III. Illustrated. 37/6 net.

"Can be recommended confidently to all students of Telecommunications."—*Post Office Telecommunications Journal*.

Alternating Current in Telecommunications

By W. T. Palmer, B.Sc.(Eng.), Wh.Ex., M.I.E.E., A.M.I.Mech.E. A sound introduction to the basic principles of alternating current theory for engineers who are commencing their studies for a career in telecommunications. With 41 illustrations. 4/- net.

Telephony (2 vols.)

By J. Atkinson, A.M.I.E.E., Area Engineer, Post Office Engineering Department. A standard textbook for Post Office engineers and students. With over 1,500 illustrations. Vol. 1 (General Principles and Manual Exchange Systems), 35/- net. Vol. II (Automatic Exchange Systems), 55/- net.

From booksellers. Published by

SIR ISAAC PITMAN & SONS, LTD.,
 Parker Street, Kingsway, London, W.C.2

SUB-MINIATURISATION

HIVAC

FIRST
 TO GET DOWN TO IT!

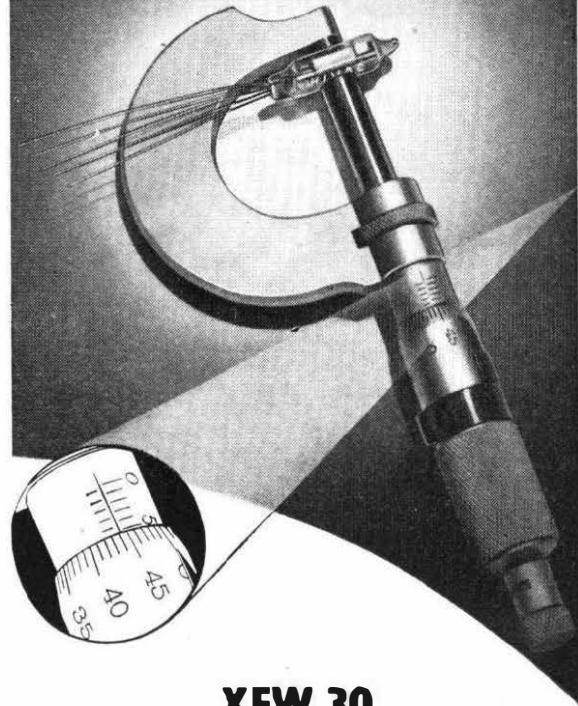

XFW 30

Beam Tetrode Subminiature Amplifier

TYPICAL OPERATION

Filament Voltage	0.625v
Filament Current	12½mA
H.T. Supply Voltage	22½v
Anode Load	1 to 2MΩ
Screen Resistance	3MΩ
Stage Gain	32

The maximum cross-section is only 8mm. by 6mm. with a glass length of 27.0mm. and the normal filament current is 12½ mA.



These features in conjunction with the high efficiency of the XFW30 permit still greater scope to the designer of the most modern hearing aids and other small electronic equipment.

Hivac Ltd.

Telephone: HARrow 2655
 GREENHILL CRESCENT, HARROW-ON-THE-HILL, MIDDLESEX

Audio power measurement

by **MARCONI**

With a power range from $20\mu\text{W}$ to 10W , an impedance range from 0.625Ω to $20,000\Omega$ and an excellent frequency characteristic extending to $25,000\text{ c/s}$, Output Power Meter type TF 893 meets—with accuracy—practically every requirement of the telecommunication engineer. Included among its many refinements is automatic compensation for ambient temperature.



MARCONI instruments

Signal Generators — Bridges — Valve Voltmeters — Frequency Standards
Wave Meeters — Wave Analysers — Beat Frequency Oscillators

MARCONI INSTRUMENTS LTD · ST. ALBANS · HERTS · PHONE: ST. ALBANS 6161/7

Midland Office: 19 The Parade, Leamington Spa.

Northern Office: 30 Albion Street, Hull.

Export Office: Marconi House, Strand, London, W.C.2

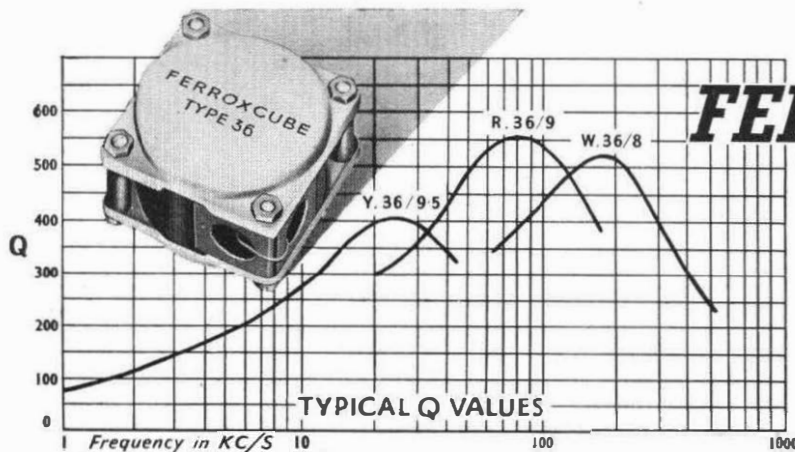

FERROXCUBE

FERROMAGNETIC FERRITE

For Line Communications :

IN THE design of Mullard pot core assemblies types 36 and 25 full advantage is taken of the characteristics of Ferrocube to produce inductances of remarkably high "Q" factors. This, combined with ease of winding, makes these cores very suitable for use in filter networks and wherever high quality inductances are required.

Fine adjustment of inductance is obtained by control of the air gap rather than by variation of the turns.

The good screening properties of the Ferrocube and the convenient shape of the assemblies, which allows stacking or individual mounting, are other features which distinguish these Mullard cores.

OUTSTANDING FEATURES

- ★ Low hysteresis coefficient
- ★ High values of inductance
- ★ Low self capacitance
- ★ Controllable air gap facilitating inductance adjustment
- ★ Self screening
- ★ Controlled temperature coefficient
- ★ Operation over a wide frequency range
- ★ Ease of winding and tapping
- ★ Easily mounted

PLEASE WRITE FOR FULL DETAILS



Mullard FERROXCUBE

FERROMAGNETIC FERRITE

MULLARD LIMITED · CENTURY HOUSE · SHAFTESBURY AVENUE · LONDON · W.C.2

(MF375)

AUTOMATIC VOLTAGE REGULATORS by B.P.T.

Maintaining a constant voltage unaffected by variation in the supply voltage, frequency, load and load power factor is a problem which can be solved by the aid of our standard range of Automatic Voltage Regulators. For single phase operation there are 11 models from 12½ to 240 amps, for three-phase there are 13 models from 7½ to 150 amps. Three typical models are illustrated from our standard range of wall or floor mounting types.

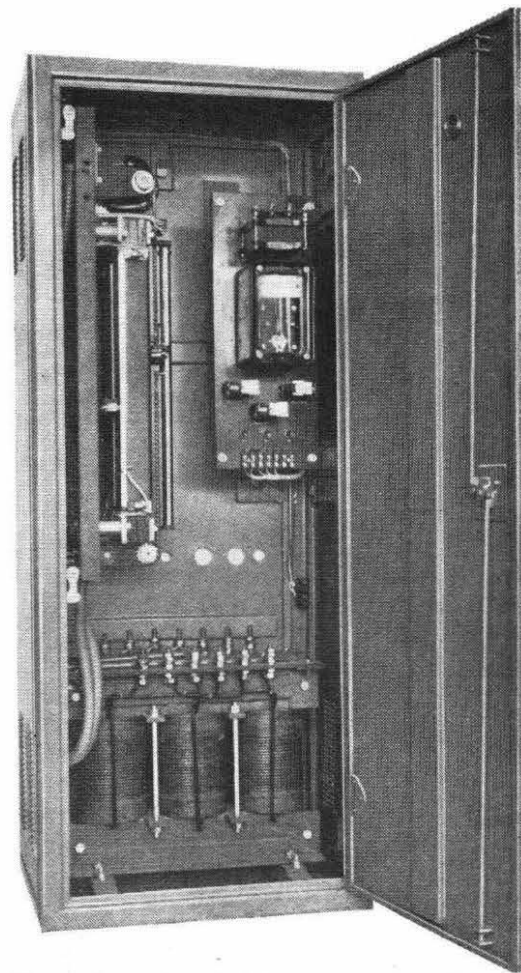

Top: 3-phase, air cooled, floor mounting (cubicle) model. Input 440V \pm 10%, output 440V \pm 1%, 40 amps.

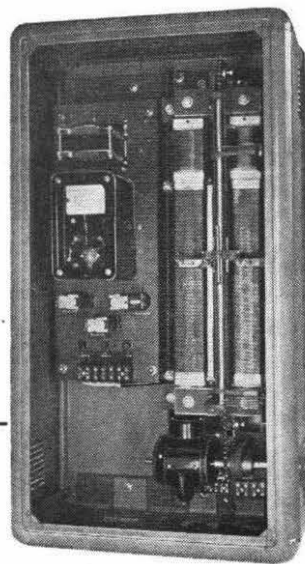

Left: Single-phase, air cooled, wall mounting model. Input 250V \pm 15%, output 250V \pm 1%. 25 amps.

Right: 3-phase, air cooled, wall mounting model. Input 440V \pm 10%, output 440V \pm 1%, 7½ amps.

Please write for further information and literature.

BRITISH POWER TRANSFORMER CO. LTD.

QUEENSWAY, PONDER'S END, MIDDLESEX Phone: HOWARD 1492 Grams: 'Vitrohm Enfield'

Know this village? If you worked at the Alton Battery works you'd know it well—and a dozen others like it. You'd know the lanes that lead to each. You'd know the streams—and the fish in them: the pubs and the beer they cool in their cellars, the teas they serve on their lawns . . . Alton's a country town—and the men it breeds are countrymen at heart. Men with roots in their birthplace. Men with a quiet pride in themselves and the patient skill of their hands. A clipped yew hedge in his garden . . . a battery plate at 'the Works' . . . *making something better than merely well comes very naturally to an Alton man.*

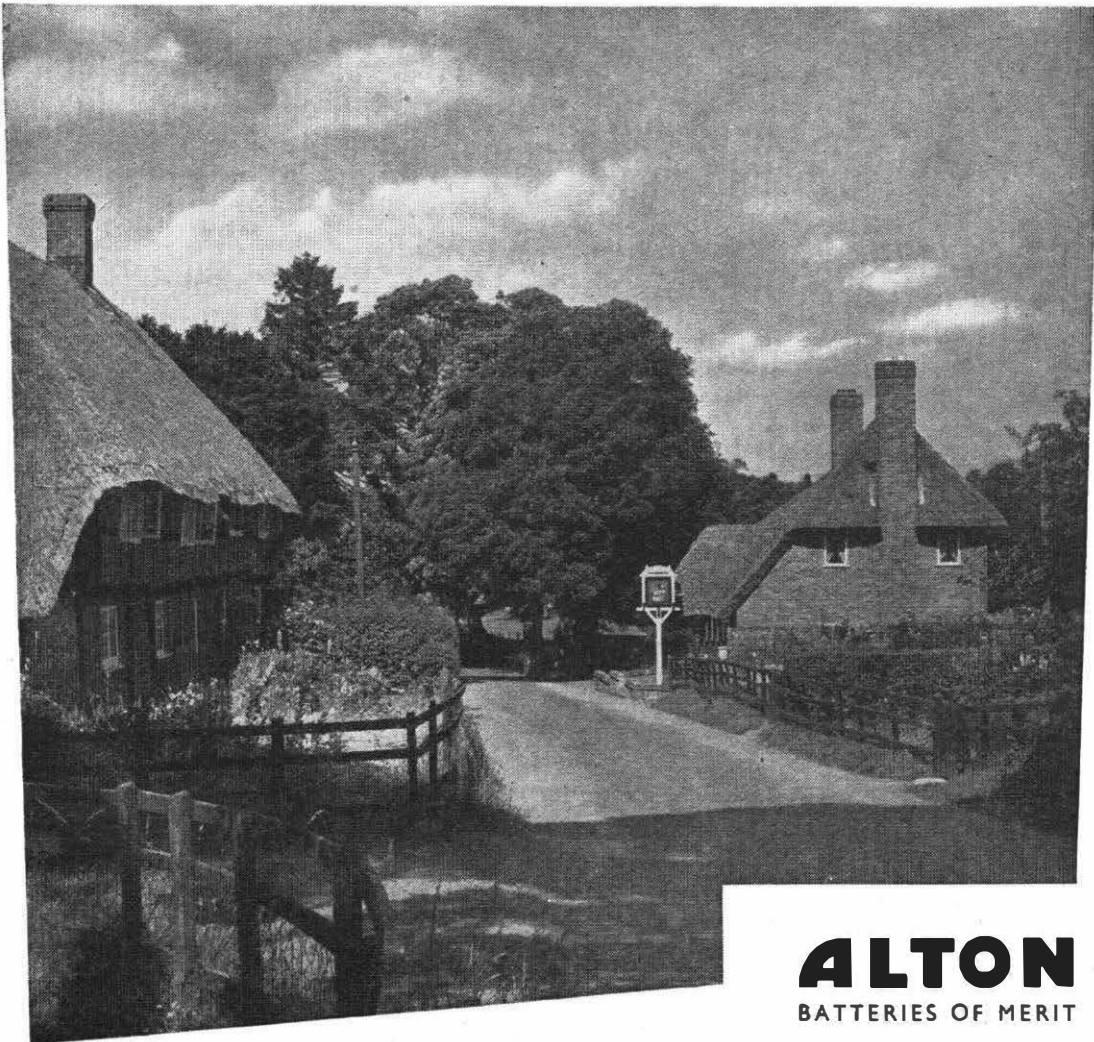

ALTON
BATTERIES OF MERIT

Alton stationary batteries: 10 to 15,000 Ah. Also in regular production, renewal plates for all makes of battery, British and Continental

A26A

The Alton Battery Company Limited · Alton · Hampshire · Telephone: Alton 2267 and 2268 Telegrams: Battery, Alton

MARCONI communication systems



serve mankind

Communications . . . across the wastes of desert and ocean, and through impassable swamps and jungles . . . were largely unsolved until Marconi invented the miracle of radio. At one stroke he substituted ease for difficulty, and opened up a new era in the history of

man. For over 50 years the Company which Marconi founded has made communications its business. Its experience in this field is unique. If you have a communications problem of any sort, anywhere, Marconi engineers are entirely at your service.



SURVEYED



PLANNED



INSTALLED

DUBILIER

MICA DIELECTRIC CAPACITORS

*Eminently suitable for H.F.
Transmitting and R.F. Heating
Circuits.*



Makers of the first, and of the largest Mica Capacitors in the World. Dubilier have maintained the lead in this important branch of Capacitor Engineering. The example shown is a solid filled mica capacitor in a substantial porcelain container. Screw threaded metal terminal bosses with large surface area contacts provide a convenient means of mounting.

These capacitors are designed for use as Grid and Anode stoppers, as By-Pass Capacitors in radio-frequency power circuits where a small radio-frequency component is superimposed upon a higher D.C. or low-frequency A.C. voltage, and in oscillatory circuit positions in low power radio-frequency transmitters and similar equipment.

Full details of these and other outstanding Capacitors are available upon application.

DUBILIER CAPACITORS

DUBILIER CONDENSER CO. (1925) LTD., DUCON WORKS, VICTORIA RD., N. ACTON, LONDON, W.3.
Phone: Acorn 2241 (5 lines). Grams: Hivolcon, Wesphone, London. Cables: Hivolcon, London, Marconi International Code

D69

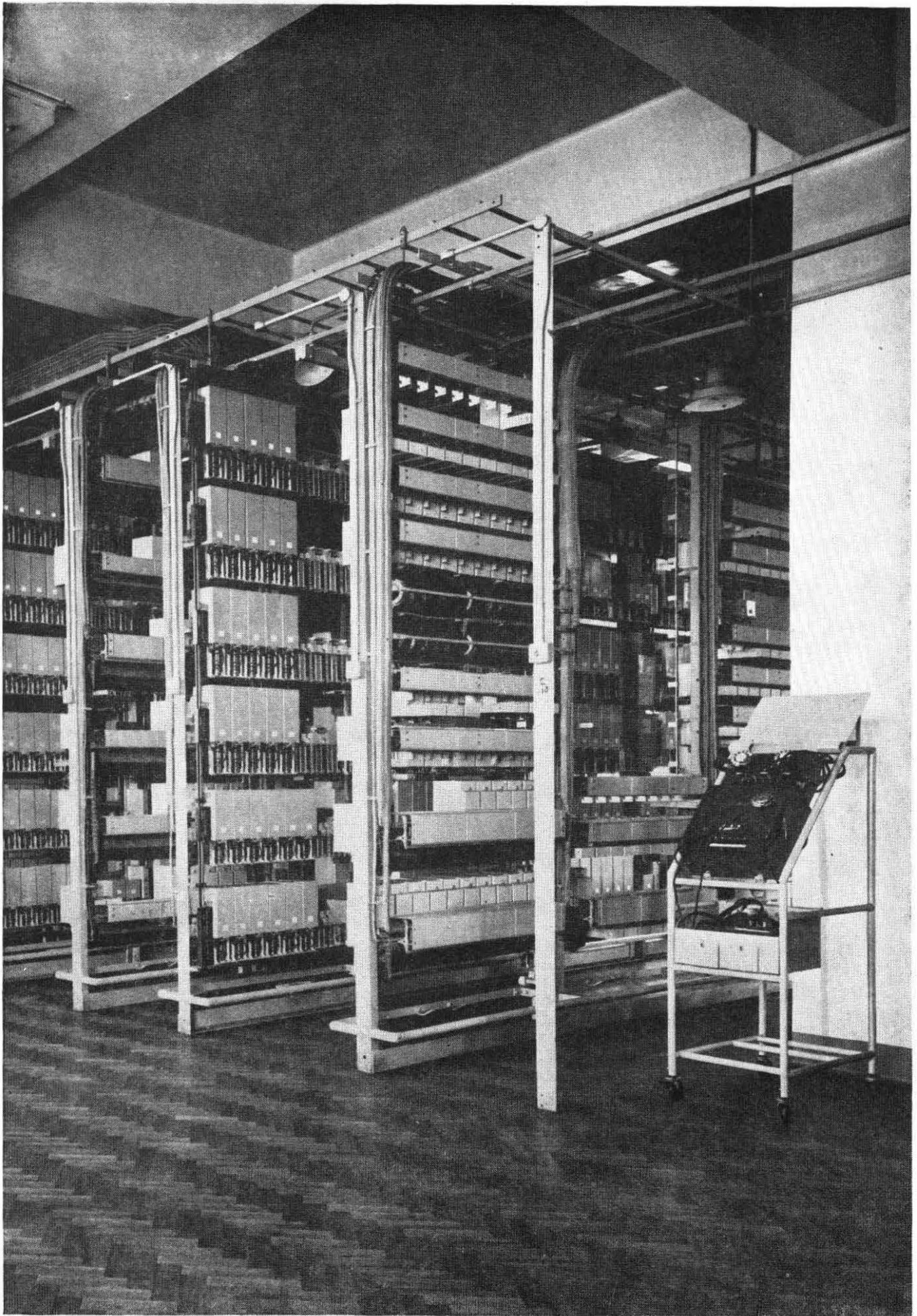

ANOTHER STROWGER EXCHANGE



WEMBLEY AUTOMATIC EXCHANGE is the latest to be installed in the London Director area by Automatic Telephone & Electric Company Limited. Dialling facilities are provided for a maximum of 10,000 subscribers to 185 exchanges

and the majority of the 1,500,000 telephones in the area.

The Strowger two-motion selector, thousands of which form part of the Wembley exchange equipment, is the principal selecting mechanism and incorporates in its design all the facilities which many years' operational experience have shown to be necessary, yet retains the simple straightforward step-by-step principle of operation characteristic of the Strowger system. These qualities are apparent to a marked extent in the type 32A Mark II Selector, which is the most recent model. To-day this selector offers the most suitable basis for automatic telephone systems of any size. Its simplicity, economy, reliability and ease of maintenance are the factors of principal appeal to telephone administrations in all parts of the world.



TYPE 32A MARK II SELECTOR

Automatic Telephone & Electric Co. Ltd.

Strowger House, Arundel Street, London, W.C.2.

Telephone: TEMple Bar 4506. Telegrams: Strowger, Estrand, London. Strowger Works, Liverpool 7



AT.7731-AA23

How automatic is a telephone exchange ?

In operation it is fully automatic, but there is nothing automatic about its maintenance. Only man-hours expended by skilled personnel will guarantee efficient maintenance.

Since the virtues and failings of a telephone system must depend ultimately on the ease or difficulty of maintenance, the G.E.C., after years of research, has re-designed apparatus used in the Strowger system, to obtain greater reliability, maximum ease of adjustment and instant accessibility. The results are now apparent in the new G.E.C. two-motion selectors, the heavy- and light-duty uniselectors and the trigger dial. All of them can now be maintained with much less skill and in much less time than ever before. Combined with the electrical simplicity exclusive to the Strowger system, these components mean that automatic exchanges manufactured by the G.E.C. are the most valuable investment an Administration can make.

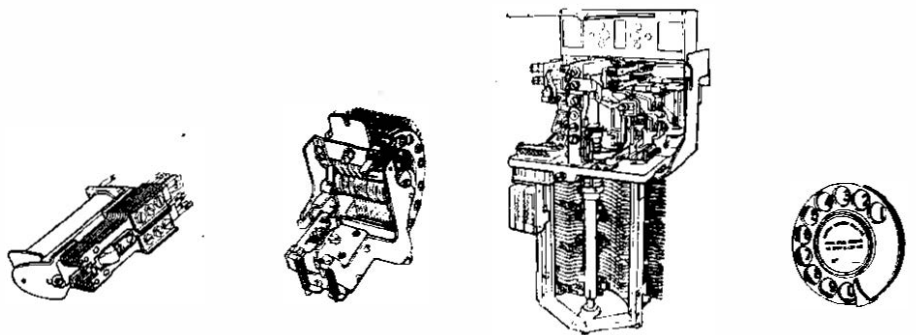

CUTTING COSTS OF MAINTENANCE

CLOSE FITTING and grooved number ring excludes dust from the front.

Transparent rear cover available for dusty locations.

FRONTAL APPEARANCE enhanced by highly polished stainless steel finger-plate of light and durable construction.

IMPULSE RATIO

closely controlled by a precision-made impulse wheel actuating an articulated trigger.

- (a) *Ensuring positive action.*
- (b) *Giving maximum pre-impulsing delay.*
- (c) *Eliminating clipped or spurious impulses.*

Adverse effect on ratio due to any wear on impulsing parts is offset by wear on contacts.

Known contact gap simplifies ratio setting on site.



SPEED MAINTAINED through:

Accurately hobbled gear train employing worm wheel of fine fabric laminated plastic.

Finely finished governor worm, weights and cup.

*Full particulars are given
in Leaflet DSL 1*

THE GENERAL ELECTRIC CO. LTD. OF ENGLAND
Telephone, Radio & Television Works, Coventry

G.E.C.

OF ENGLAND

Telephone link

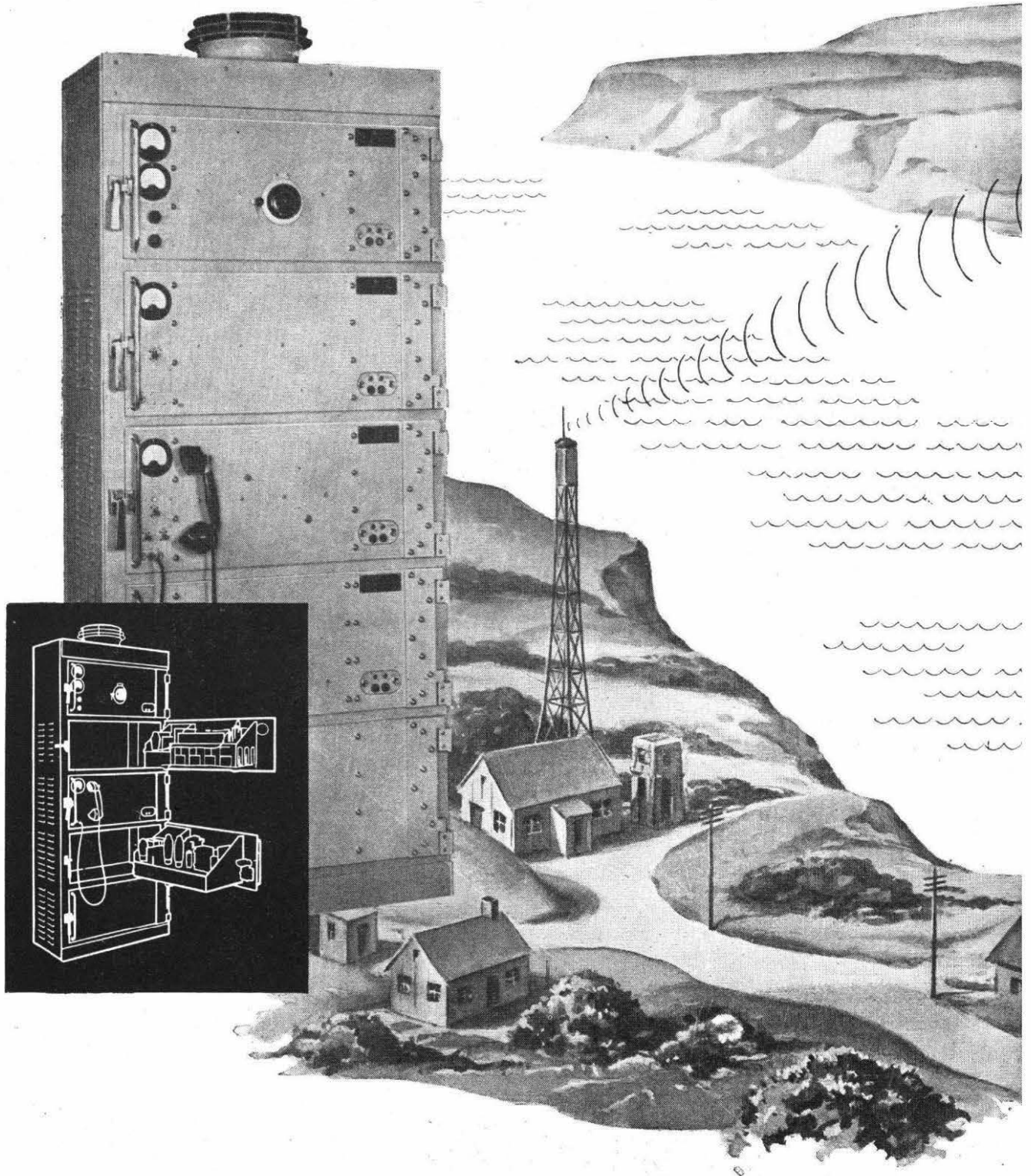

by Radio

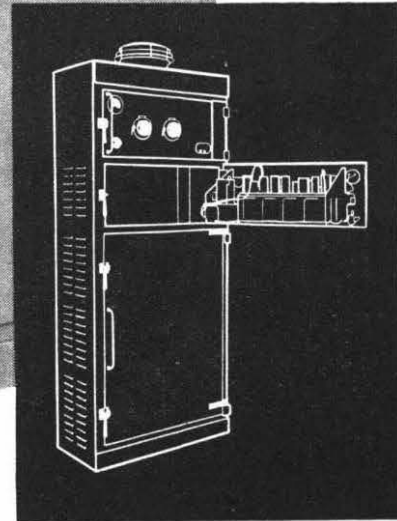
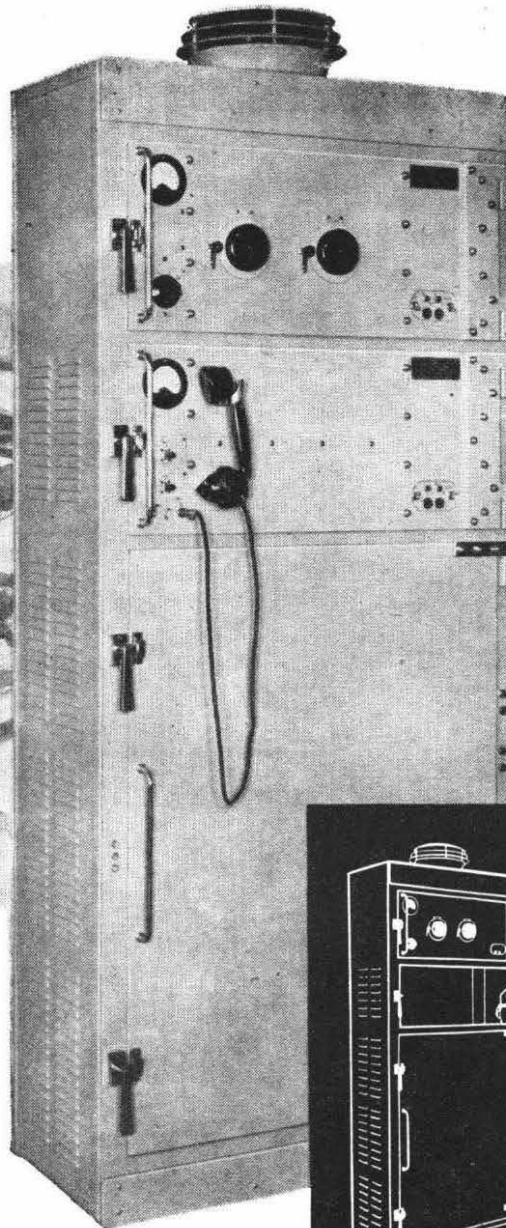
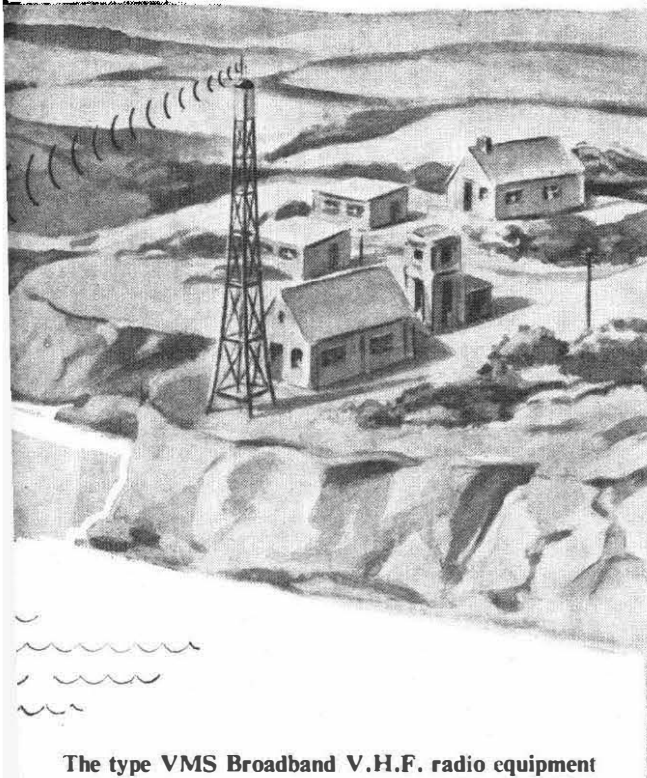

The type VMS Broadband V.H.F. radio equipment has been designed to overcome the tele-communications problem existing in areas where the provision of landlines for trunk communications is impracticable or uneconomical.

Operating in the V.H.F. band, the system caters for the transmission of up to 36 telephone channels to C.C.I.F. standards. When used in conjunction with VMR repeater equipment links up to several hundred miles in length can be established.

VMS/VMR equipment has been planned on the basis of maximum accessibility to simplify maintenance; the sub-unit construction employed facilitates fault localisation, and permits the rapid replacement of defective units by semi-skilled staff.

A.T.M. engineers are always prepared to study your problems, and to recommend the most suitable equipment for your complete system from the comprehensive range of A.T.M. products, which includes channelling equipment of all types and other essential V.H.F. radio items, such as aerials, filters, automatic changeover gear, towers and feeder cables. In addition, specially equipped teams are available to conduct field surveys in any part of the world to ascertain the most suitable equipment and station sites for any project.



AUTOMATIC TELEPHONE & ELECTRIC CO. LTD.,

R & T. DIVISION, STROWGER HOUSE, ARUNDEL STREET, LONDON, W.C.2
Telephone: TEMple Bar 9262. Cablegrams: Strowgerex, London.

AT14251-AA807

SIEMENS

MULTI-CHANNEL A.C. TELEGRAPH EQUIPMENT

TYPES CTS/6—CTS/24

FEATURES:

From 6 to 24 channels available.

Mounts 12 channels on one side of a 10' 6" bay.

Additional channels beyond 12 obtained by group modulation.

Associated bays provide duplicate generators or valve oscillators for tone supplies or for channel and group frequencies.

Capacity of bays, 10 systems.

Tone frequencies are 420 to 3,180 c/s at 120 c/s spacing, and equipment complies with CCIT requirements in all respects.

Wide transmission level range for low distortion.

Sending modulator and receiving detector-amplifier panels readily detachable for maintenance by plug and jack connections.

Equipment operates from 24V and 130V batteries or from separate A.C. mains Power Bay.

Testing equipment provided as standard on the Channel Bay.

Further particulars on application

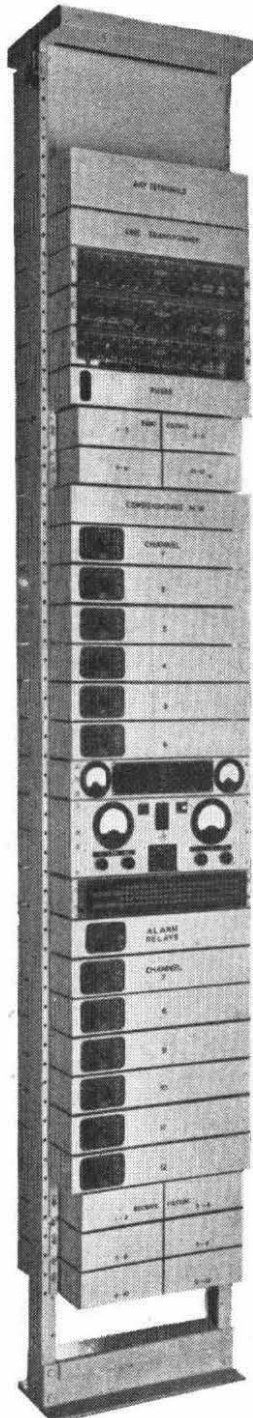

CHANNEL BAY

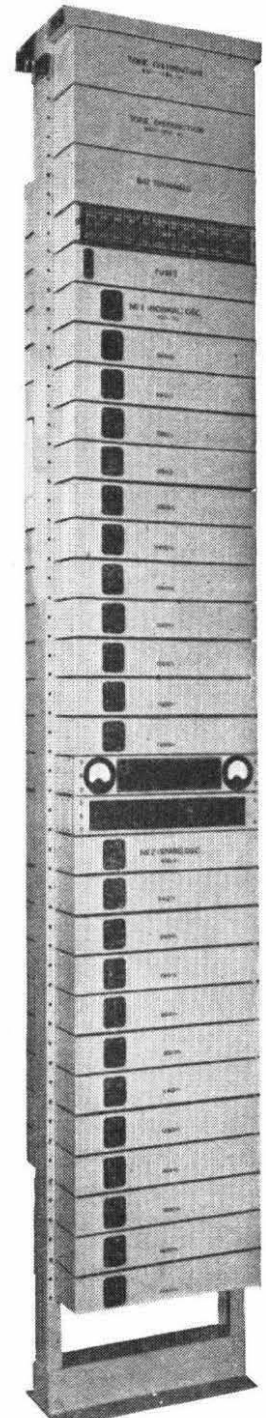

OSCILLATOR BAY

SIEMENS BROTHERS & CO., LIMITED

WOOLWICH . LONDON . S.E.18

Telephone: Woolwich 2020

Creed



No. 47 Tape Model Teleprinter

No. 7 Page Model Teleprinter

**printing
telegraph
systems**

Creed & Company Limited
TELEGRAPH HOUSE · CROYDON · ENGLAND

Standard's contribution

Standard Telephones and Cables Limited take pride in their contribution to the development and progressive extension of Britain's television transmission network. For the G.P.O. the Company have designed, manufactured, and installed coaxial television cables, vestigial sideband terminal equipment and a microwave radio relay system, and for the B.B.C. high power television sound transmitters.

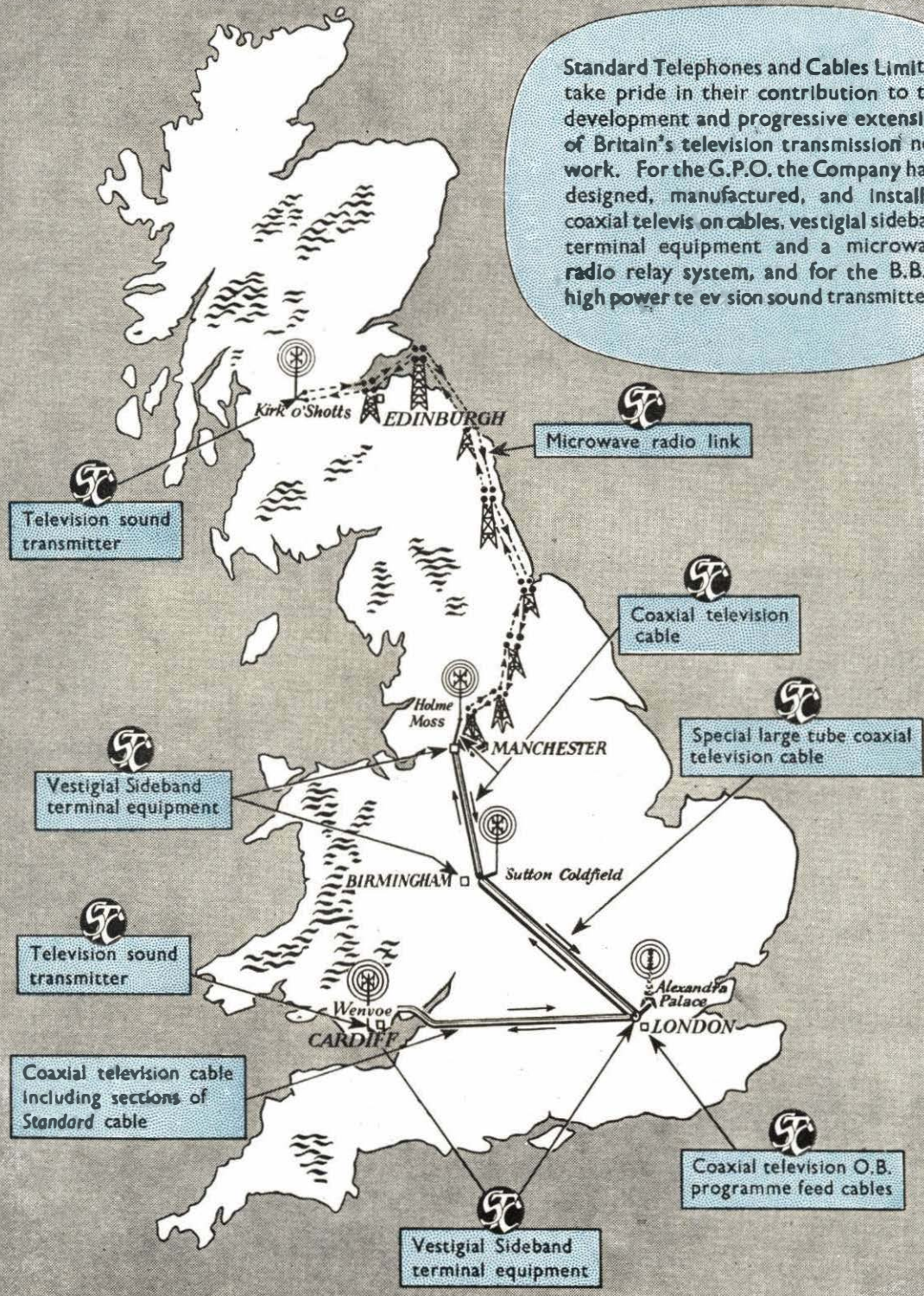

to Britain's Television Network

Installed in 1949 between London and Birmingham this cable has given perfect service since it was brought into regular use. It is designed to accommodate very-high-definition and colour television.

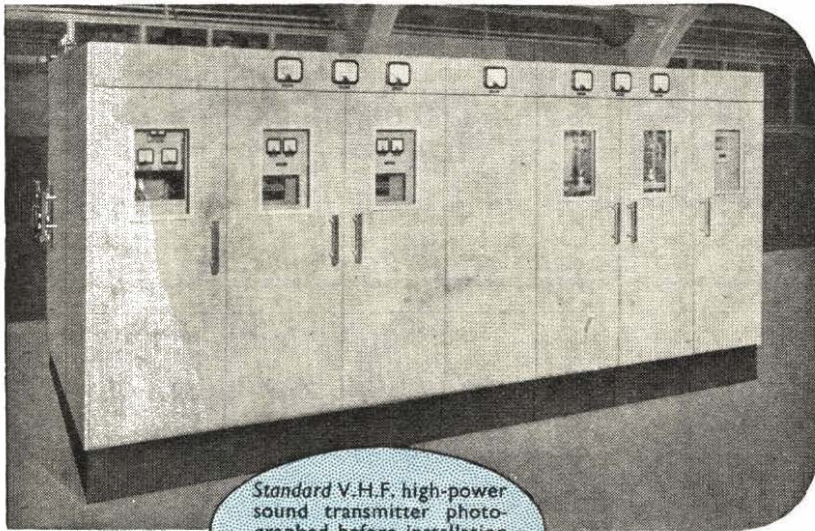
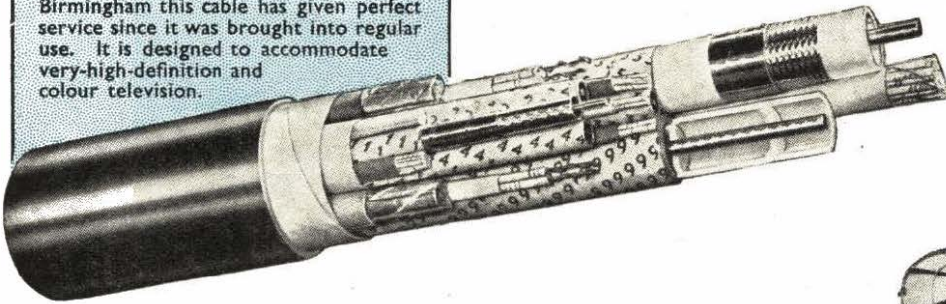

Standard V.H.F. high-power sound transmitter photographed before installation at Kirk o' Shotts. A similar transmitter is installed at Wenvoe.

Multiple-tube coaxial cable is installed between Birmingham and Manchester with Standard vestigial sideband terminal equipment.

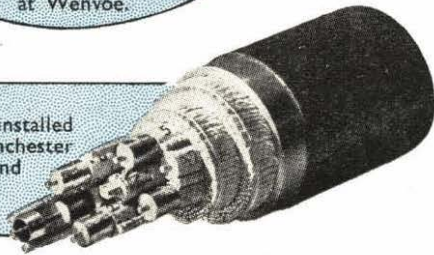

The Microwave Television Link installed between Manchester and Kirk o' Shotts, a distance of approximately 250 miles, employs beamed transmissions over line-of-sight paths. Seven repeaters, the antennæ of one of which is shown above, relay programmes in either direction.

Standard Telephones and Cables Limited

TELECOMMUNICATION ENGINEERS

CONNAUGHT HOUSE · ALDWYCH · LONDON, W.C.2

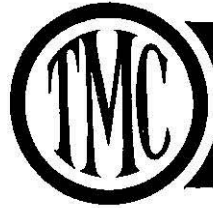
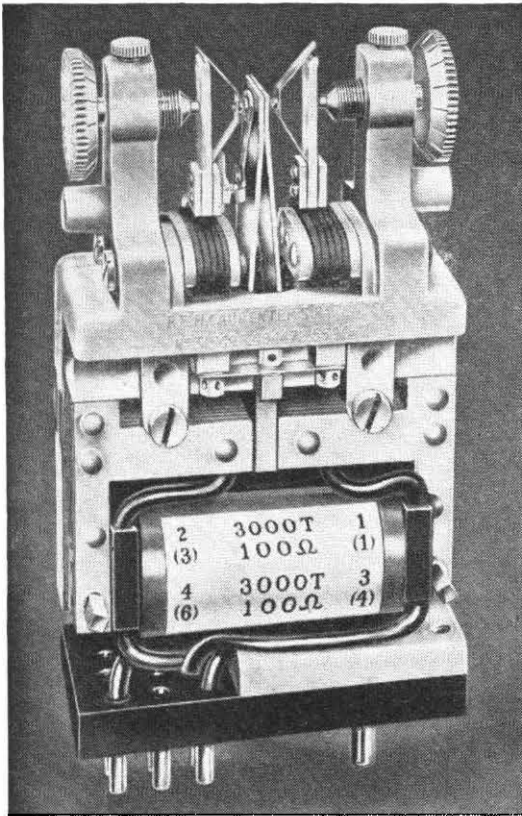

CARPENTER POLARIZED RELAY TYPE 4

The chief characteristics of this relay are low transit time—high contact pressure—freedom from contact chatter and positional error—high sensitivity—stability—symmetrical action—and ease of adjustment.

On V.F. dialling systems its use facilitates the design of sensitive receiving equipment, and on trunk telephone circuits the relay's high sensitivity enables it to respond to D.C. dialled impulses received over unrepeated trunk lines of up to 100 miles long.

It is particularly suitable as an impulse accepting relay when a minimum of signal distortion is imperative, and because of the excellent change-over action and absence of contact chatter the relay is unequalled for impulsing the selector magnets in teleprinter automatic switching systems.

The relay responds, satisfactorily to frequencies up to 100 c/s, when the contact gap is adjusted to 0.004 in. nominal, without serious bias disturbance. It can be left connected to line whilst awaiting a clearing signal, there being little distortion of through signals since the total leak can be of the order of 10,000 ohms.

Dimensionally the relay is interchangeable with the "3000" type relay. Terminations can either be made by means of a 12-pin plug base as illustrated, or with soldering tags in place of the pins. Protection is given by a magnetic screen and a transparent cap which is removable for contact adjustments.

Complete details supplied on request.

Manufactured by the Sole Licensees:—

TELEPHONE MANUFACTURING COMPANY LIMITED

Contractors to Governments of the British Commonwealth and other Nations

HOLLINGSWORTH WORKS · DULWICH · LONDON S.E.21 TEL: GIPSY HILL 2211 (10 LINES)

ZEVA

Electric

SOLDERING TOOLS

for **SPEED, ECONOMY**
and **BETTER WORK**



The news that this famous range of Soldering Irons and Crucibles is again available has been welcomed in numerous branches of industry everywhere. Zeva Tools are unquestionably without equal for efficiency, economy and trouble-free long life.

- ZEVA heating elements never need renewal. They last the life of the tool.
- ZEVA Irons can be left switched on all day without detriment to the tool.
- ZEVA current consumption for rated temperature is less than any other make of tool.
- ZEVA initial cost is the only cost.
- ZEVA Irons are guaranteed.

Write for complete
Illustrated Catalogue:—

THE AUTOMATIC COIL WINDER & ELECTRICAL EQUIPMENT CO., LTD.
Winder House, Douglas Street, London, S.W.1

Phone: VICTORIA 3404-9

Z1/PZ/ZWS

G.N.T.

UNDULATORS MODEL 309 * 310

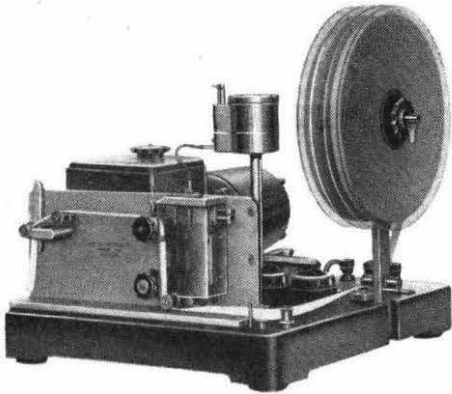

Model 309 is fitted with a single recording part while model 310 has two recording parts and is useful in connection with diversity reception.

Both models can record signals up to 300 w. p. m. Supplied with A. C. or D. C. motors as required.

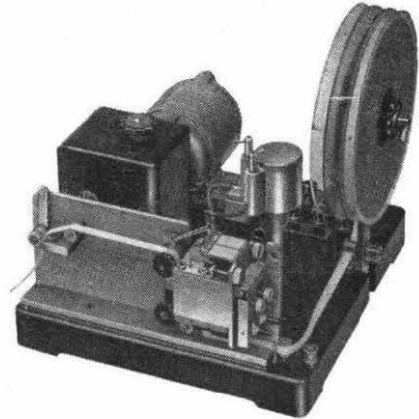

* Write for comprehensive catalogue.

THE GREAT NORTHERN TELEGRAPH COMPANY'S FACTORY

4, SYDHAVNS PLADS
COPENHAGEN SV . DENMARK

LONDON OFFICE: 5, ST. HELENS PLACE
LONDON E.C.3.

**POWER LIGHTING
TELEPHONY**

HACKBRIDGE
Cable Company Limited

The illustration depicts a street scene with a utility pole in the foreground. A truck is parked on the right, and a person is standing near a cart on the left. In the background, there are houses and a church spire. The text 'POWER LIGHTING TELEPHONY' is overlaid on the scene. A circular logo for 'HACKBRIDGE CABLES' is in the bottom left corner. A 'G.P.O.' mailbox is visible in the foreground.

KELVIN WORKS, HACKBRIDGE, SURREY
In Association with BRYCE ELECTRIC CONSTRUCTION CO. LTD.
Branches at BIRMINGHAM, BRISTOL, CARDIFF, MANCHESTER, NEWCASTLE, SHEFFIELD

FOR E.H.T. Supplies

Type 36EHT rectifiers contain high-voltage "Westalite" elements resulting in a greatly reduced length of unit for any given output. They have been developed to meet the demand for small, compact metal rectifiers to provide E.H.T. in many forms of equipment where the current demand is unlikely to exceed 2 mA D.C., as, for example, cathode ray tubes, electron multipliers, condenser storage devices, etc. For further information and tables of outputs of these . . .

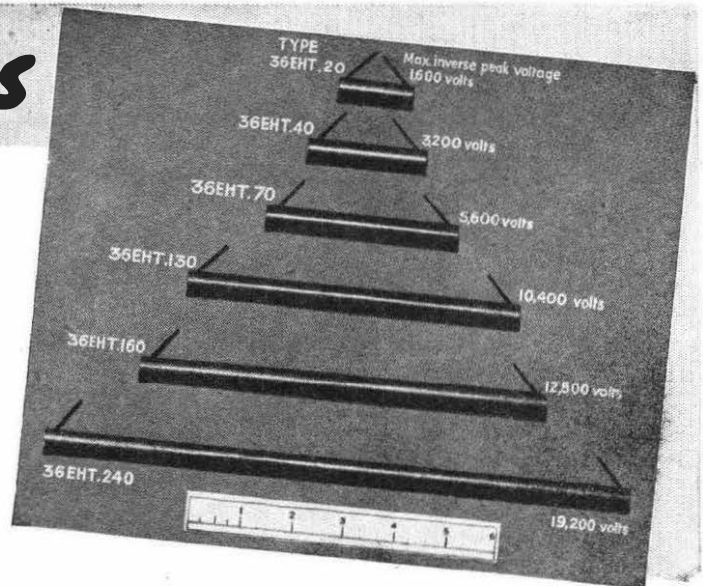

WESTINGHOUSE
WESTALITE

36EHT MINIATURE HIGH-VOLTAGE RECTIFIERS

write for Data Sheet No. 60 to . . .

Dept. P.O. 10,

WESTINGHOUSE BRAKE & SIGNAL CO., LTD., 82 York Way, King's Cross, London, N.1

SULLIVAN & GRIFFITHS
DIRECT READING
VARIABLE CONDENSERS
WITH NOVEL AIR CAPACITANCE
DECADE RANGE EXTENSION

This air dielectric condenser comprises a decade of air capacitance and a continuously variable air condenser thus giving a scale accuracy ten times that of an ordinary variable condenser of the same range.

Thus a decade of capacitance is provided—permanent in value and entirely free from loss, the only loss present in the complete combination of decade and variable condenser being that due to the solid insulating material which is ordinarily employed in the construction of the latter.

The variable condenser has a range of $100\mu\text{F}$ which is extended to $1100\mu\text{F}$ by ten increments of $100\mu\text{F}$, all adjusted with accuracy so that the decade is absolutely direct reading in μF , no corrections or calibration being necessary.

Electrical Standards for Research and Industry

Testing and Measuring Apparatus
for Communication Engineering

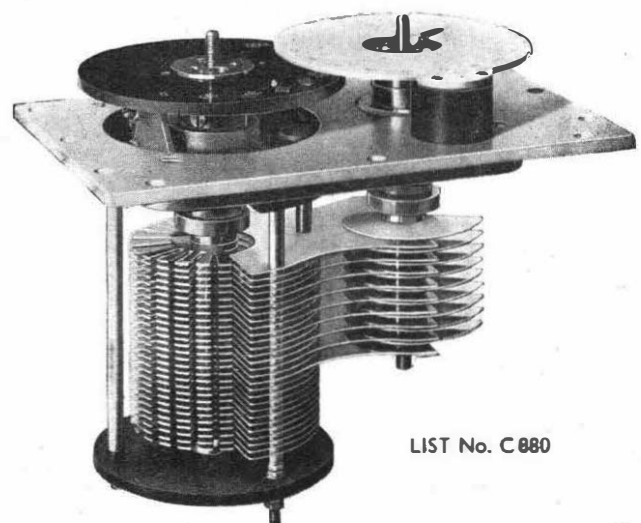

LIST No. C 880

H. W. SULLIVAN, LTD., LONDON, S.E. 15.

POWER *behind the lines*

TUNGSTONE PLANTE CELLS are being supplied to the British Post Office and Post and Telegraph Departments in many countries overseas. They conform fully to G.P.O. Standard specifications.

OPEN TYPE CELLS

Similar to the illustration here, these are available in glass and/or lead lined wooden boxes in capacities from 100 a.h. to 5000 a.h.

REPLATALS

We are in a position to supply plates for the replating of any existing Plante Battery.

ENCLOSED TYPE CELLS

As illustrated on the left these are in moulded glass boxes with sealed-in lid. Capacity range from 10 a.h. to 200 a.h.

HIGH VOLTAGE TELEPHONE BATTERIES

Portable Type. Standard layout for 50 volts, in waxed hardwood crates, exactly to the requirements of the G.P.O.

Overseas customers are invited to cable or write their enquiries for batteries or parts. Visitors to London are welcome at our offices (just off Fleet Street).

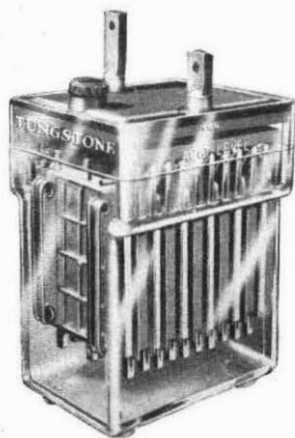

TUNGSTONE *Batteries*

For further particulars write: TUNGSTONE PRODUCTS LIMITED
10 SALISBURY SQUARE · LONDON · E.C.4 · ENGLAND · Cables: "Dilutum" London

LONG DISTANCE TRUNK LINE SIGNALLING ...

This generator provides the X and Y tone voice frequency signalling currents for dialling and signalling over the trunk network and incorporates impulsing springs for chopping the tones.

The generator operates on a 46 to 52 volt battery. The speed, tone frequency and impulsing rate are controlled to high accuracy by a Type 4259 speed governor. The output per tone is 4 watts, 20 volts, ± 0.5 db, with unwanted components of the waves 28 db below the fundamental.

For further detailed information write for leaflet A 10.

WITH A FREQUENCY ACCURATE
TO 0.1% OVER LONG PERIODS OF
CONTINUOUS OPERATION

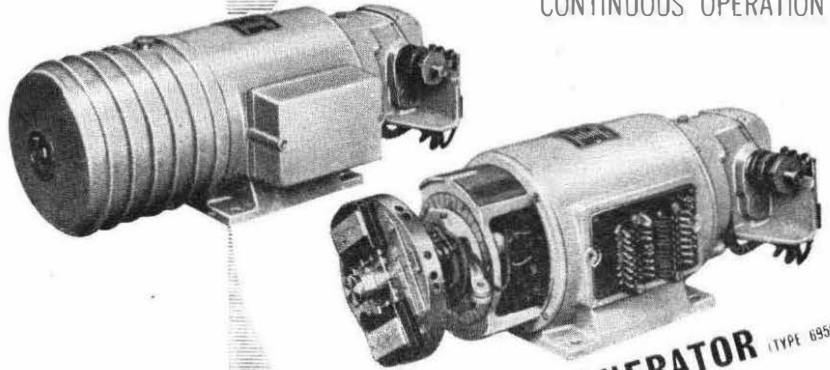

TWO VOICE FREQUENCY GENERATOR (TYPE 6950)

WALTER JONES & CO. (ENGINEERS) LTD.
NEWLANDS PARK, SYDENHAM, LONDON, S.E.26 • TELEPHONE: SYDENHAM 6264

ELECTRICAL MEASURING INSTRUMENTS OF THE HIGHER GRADES

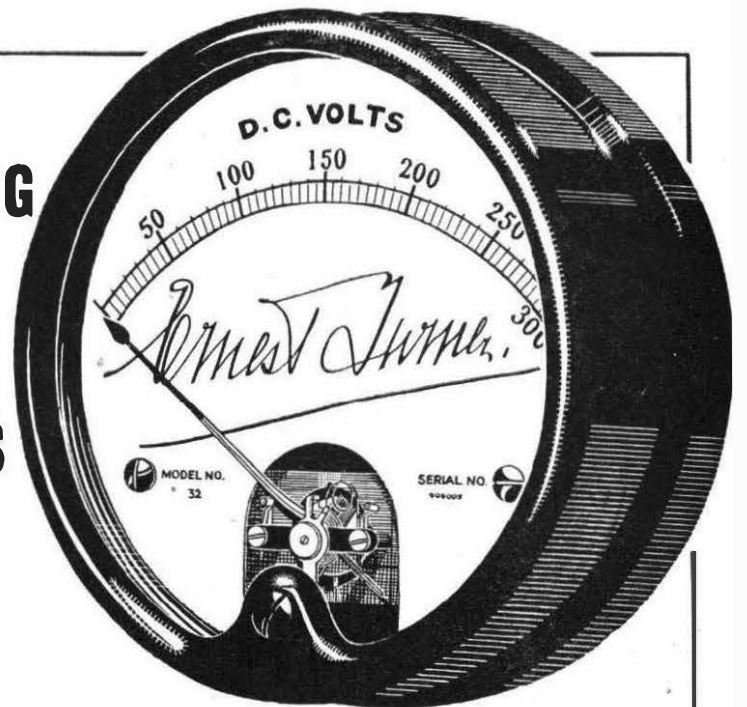

ERNEST TURNER ELECTRICAL INSTRUMENTS LTD.
CHILTERN WORKS, TOTTERIDGE AVENUE, HIGH WYCOMBE, BUCKS.
Telephone: High Wycombe 1301/2
Telegrams: Gorgeous, High Wycombe



**Build
your own
equipment**

with

DEXION

SLOTTED ANGLE

- ★ Can be used over and over again
- ★ No drilling, measuring or painting
- ★ Just cut it and bolt it, that's all!

Write or telephone for illustrated literature D.29

DEXION 189, REGENT STREET
LONDON, W.1
L I M I T E D Telephone: REGent 4841

SOUND INSTRUCTION by Postal Method

The I.C.S., largest school in the world devoted to spare-time training by the postal method, offers you highly specialised Courses for the following examinations:

- P.M.G. Certificates for Wireless Operators.**
- C. & G. Illumination Engineering (Inter.)**
- C. & G. Electrical Engineering Practice, Installation and Telecommunications.**
- Graduateship of the B.I.R.E.**
- C. & G. Radio Servicing Certificate (R.T.E.B.)**

I.C.S. Examination students are coached till successful.

Other Courses meet the requirements of all who desire to qualify for responsible positions in Electric Power, Illumination, Heating and Traction Systems. Equally successful is our instruction for Radio Engineers, Radio Servicemen, and in Elementary Radar and Electronics, Advanced Short-Wave Radio and Television Technology.

Fees are moderate and include *all* books required.

WRITE FOR OUR FREE BOOKLET and state the particular subject or Examination in which you are interested.

Generous Discount to H.M. Forces.

YOU MAY USE THIS COUPON

International Correspondence Schools Ltd.

Dept. 165A, International Buildings, Kingsway, London, W.C.2

Please send me, free of charge, your special

booklet on

Name..... Age.....

(BLOCK LETTERS, PLEASE)

Address

.....



TELEGRAPH DISTORTION MONITOR TYPE 787

- Monitors up to ten lines.
- Double or single current circuits.
- May be supplied to operate at either 50 or 45.5 bauds.
- Permissible distortion variable between 0 and 50%.

This instrument enables teleprinter signals on up to ten telegraph lines to be monitored for distortion, the amount permissible being set by a control on the front panel. One line may be monitored continuously or each line in turn for a period of one minute. When excessive timing errors occur, the alarm lamp lights, and, if desired, an external bell or buzzer may be operated.

Full details of this or any other Airmec instrument will gladly be forwarded upon request.

AIRMEC LABORATORIES **LIMITED**
HIGH WYCOMBE · BUCKINGHAMSHIRE · ENGLAND
TEL.: HIGH WYCOMBE 2060 CABLES: AIRMEC HIGH WYCOMBE

TELEPHONE DISTRIBUTION

EQUIPMENT

ENGINEERS WHO ARE INTERESTED
IN TELEPHONE DISTRIBUTION EQUIP-
MENT ARE INVITED TO REQUEST
SECTION T.C.13 OF OUR TELECOM-
MUNICATION CABLES CATALOGUE.

TELEPHONE:
SOUTHAMPTON
2141 (5 lines)

IRELLI-GENERAL
CABLE WORKS, Ltd., SOUTHAMPTON.

TELEGRAMS
"PIGEKAYBEL"
SOUTHAMPTON

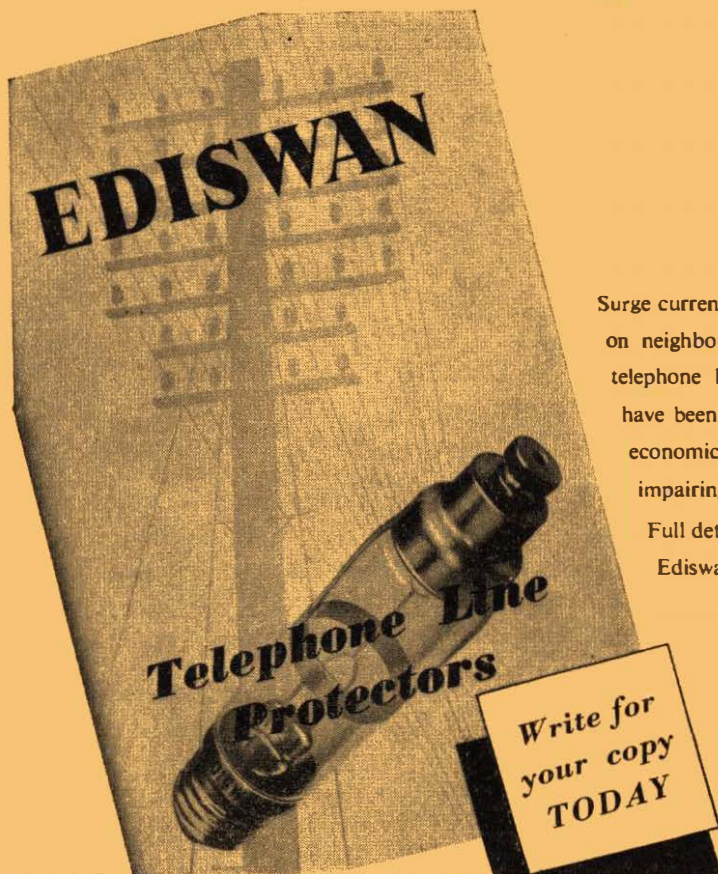

How to protect telephone lines

Surge currents, induced on telephone lines by electric storms or breakdowns on neighbouring power lines, may be effectively controlled by Ediswan telephone line protectors. These special electrode gas discharge tubes have been developed in collaboration with G.P.O. Engineers to provide economical and effective protection for telephone systems without impairing the service.

Full details of these protectors and their application is given in the new Ediswan publication C.1581 which is now available free of charge.

EDISWAN

THE EDISON SWAN ELECTRIC COMPANY, LTD.
155 CHARING CROSS ROAD, LONDON, W.C.2.

Member of the A.E.I. Group of Companies.

TE4