

THE POST OFFICE ELECTRICAL ENGINEERS' JOURNAL

Vol. 44

OCTOBER 1951

Part 3

CONTENTS

	PAGE
AN EXPERIMENTAL ELECTRONIC DIRECTOR—K. M. Heron, A.M.I.E.E., H. Baker, B.Sc.(Eng.), A.M.I.E.E., and D. L. Benson, Grad.I.E.E.	97
A NEW PRINCIPLE FOR OBTAINING IMPROVED SPEECH IMMUNITY WITH V.F. SIGNALLING RECEIVERS	102
DETECTION OF DEFECTIVE CONNECTIONS IN LINE TRANSMISSION EQUIPMENT—N. W. Lewis, Ph.D.(Eng.), M.I.E.E.	103
TEST EQUIPMENT FOR THE TELEPRINTER AUTOMATIC SWITCHING SYSTEM—A. E. T. Forster, A.M.I.E.E.	107
KIOSK TRAILERS—J. J. Moffatt, Assoc.I.Mech.E., A.M.I.E.E., and A. G. J. Fagg	112
SIGNALLING SYSTEM A.C. No. 1 (2 V.F.)—Part 2.—General Description of the New Equipment—D. C. Smith, B.Sc.(Eng.), A.M.I.E.E.	114
ELECTRONIC EQUIPMENT FOR SIGNALLING SYSTEM A.C. NO. 1—Part 1.—The New 2 V.F. Signalling Receiver (AT 4931)—J. R. Tillman, Ph.D., A.R.C.S.	118
QUARTZ CRYSTAL VIBRATORS AS CIRCUIT ELEMENTS—H. E. Pearson, B.Sc.(Eng.), A.M.I.Mech.E.	124
MINIATURISED TESTING EQUIPMENT FOR CABLE AND PAIR IDENTIFICATION—W. L. Surman, A.M.I.E.E., and G. W. Thomas	127
SIR ARCHIBALD J. GILL, B.Sc.(Eng.), M.I.E.E., F.I.R.E.	130
W. G. RADLEY, C.B.E., Ph.D.(Eng.), M.I.E.E.	131
THE VIth PLENARY MEETING OF THE C.C.I.R., GENEVA, JUNE, 1951	132
NOTES AND COMMENTS	133
INSTITUTION OF POST OFFICE ELECTRICAL ENGINEERS	135
REGIONAL NOTES	137
JUNIOR SECTION NOTES	142
STAFF CHANGES	143
BOOK REVIEWS	106, 111, 113, 117, 123, 129

Price 2/6 net

THE INSTITUTION OF POST OFFICE ELECTRICAL ENGINEERS



THE CORRESPONDENCE COLLEGE THAT PUTS YOU IN A CLASS AHEAD

POSTAL TUITION

paves the way to success in the ★
CITY & GUILDS (Telecommunications)
EXAMINATIONS

Subjects taught include :—

Telephony	Telecommunications (Principles)
Telegraphy	Telecommunications (Practice)
Lines Plant Practice	Line Transmission
Mathematics for Telecommunications	Radio

★ Each student of the College is provided with tuition until he has passed the examination for which he has enrolled.

POST THIS COUPON—TODAY!

To Dept. 24, THE BENNETT COLLEGE LTD. SHEFFIELD.

Please send me (free of charge) particulars of _____

NAME _____

ADDRESS _____

Age _____

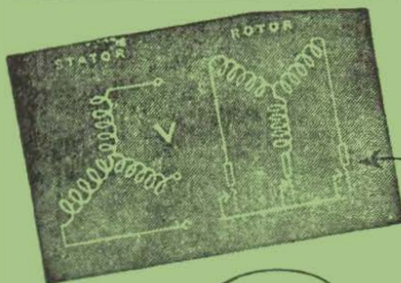

A.C. Polyphase Wound
Rotor-Rotor Rheostat.

FOR EVERY PHASE OF ELECTRICAL WORK

The British Electric Resistance Co. Ltd. can answer the multitude of resistance problems that beset the electrical circuit designer. For twenty years Berco resistances have been giving reliable and steadfast service, and the Berco range is designed to meet every requirement.

Berco engineers are specialists in resistance design and their knowledge is at your disposal.



RESISTANCES

THE BRITISH ELECTRIC RESISTANCE CO. LTD.
 Queensway, Ponders End, Middlesex

Telephone: Howard 1492

Telegrams: Vitrohm, Enfield

ea2033-AQ

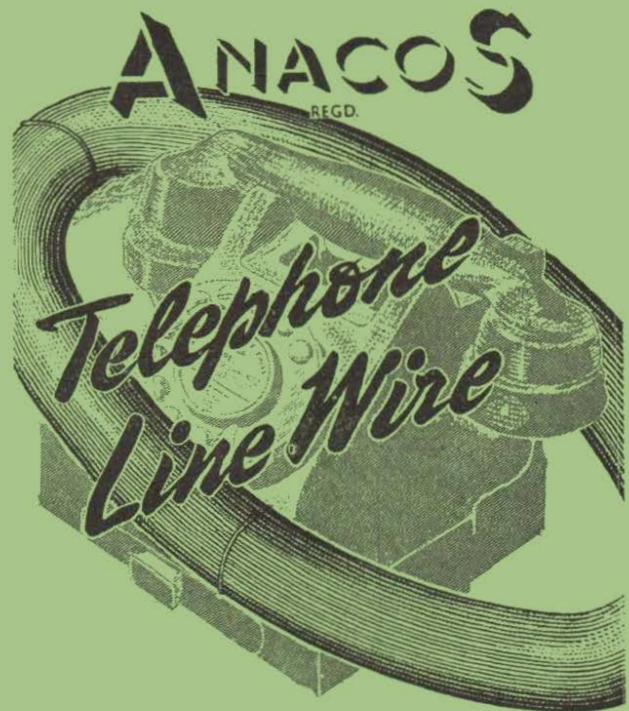

FOR THE RIGHT CONNECTION

FREDERICK SMITH & COMPANY

ANACONDA WORKS, SALFORD, 3, LANCs.

*Incorporated in The London Electric Wire Company and Smiths Limited.
 Associated with The Liverpool Electric Cable Co. Ltd. and Yacite Wire Co. Ltd.*

The tricky ones were fun!

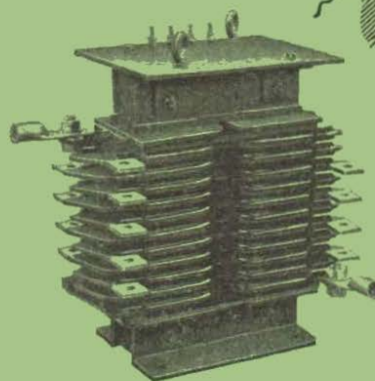

Thanks to 25 years' experience in design and manufacture of transformers, we can face most transformer 'headaches' with equanimity. If you want instruments which you can fit and forget, which will give you trouble-free service for years, write or telephone us.



SAVAGE TRANSFORMERS LTD., Nursted Road, Devizes, Wilts.
 Telephone: Devizes 536

THE POST OFFICE ELECTRICAL ENGINEERS' JOURNAL

Vol. 44

October 1951

Part 3

An Experimental Electronic Director

K. M. HERON, A.M.I.E.E.
H. BAKER, B.Sc.(Eng.), A.M.I.E.E.
D. L. BENSON, Grad.I.E.E. †

Part I.—Basic Principles and Circuit Elements

U.D.C. 621.395.34 : 621.318.572

The Research and Development Branches of the Post Office Engineering Department have for some time been interested in the application of electronics to the field of automatic telephone switching, and articles have already been published in this Journal¹ outlining general principles. The present article describes how electronic elements can be designed to perform the functions of switching and counting, and will cover, in Part 2, the circuit operation of an experimental electronic director.

Introduction.

EARLY in 1947, the Post Office Research Branch demonstrated experimental electronic equipment, based on the use of hot-cathode valves, which performed some of the basic functions of a director. Subsequently, a team was formed by the Telephone Development and Maintenance Branch of the Engineer-in-Chief's Office, to work in co-operation with the Research Branch, in order to gain experience with electronic switching techniques and produce an electronic director with full standard facilities. The director was selected for this study, not because a replacement of the existing standard was required, but because:—

- the director presented most of the problems likely to be encountered in automatic telephone switching;
- the experimental equipment produced could readily be subjected to a field trial under actual service conditions;
- the performance could be compared directly with the existing electro-mechanical equipment; and
- a field trial would yield comparatively quick results because a director performs up to half-a-million operations per annum.

Before proceeding with the design for a complete director, a study was made of the wide variety of electronic techniques available. Of these techniques, those using cold-cathode tubes appeared to have the widest application in telephone switching equipment, particularly because they do not require heater power. It was, therefore, considered desirable to obtain practical experience with these tubes; hence, it was decided to base the design on the use of cold-cathode tubes and to use hot-cathode valves where these were more convenient for circuit design. This decision resulted in a new circuit design, which permitted the complete director to be "all-electronic." A model was constructed and demonstrated early in 1950.

Circuit Arrangement.

Fig. 1 shows a block schematic diagram of the experimental equipment. The conversion relays, Fig. 1 (a), are necessary to give the same signalling conditions to the A-digit selector as the standard director, and permit the electronic director to be connected in place of a standard director. There is no other electro-mechanical equipment in the circuit.

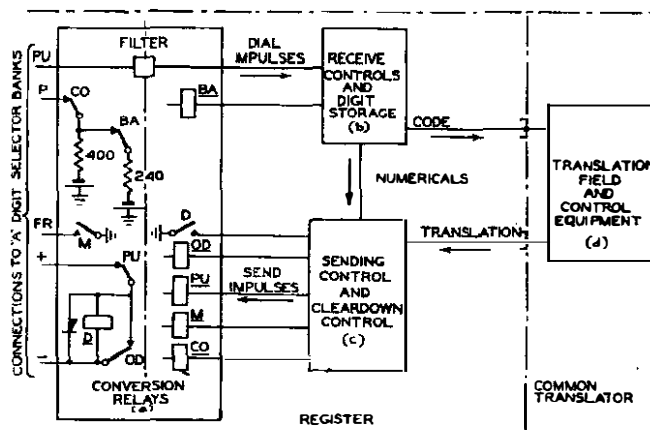

FIG. 1.—BLOCK SCHEMATIC DIAGRAM OF EXPERIMENTAL EQUIPMENT.

The electronic apparatus comprises the incoming digit-storage equipment, Fig. 1 (b), the sending and clear-down equipment, (c), and the translation field equipment (d). Parts (b) and (c) are in use throughout the holding time of the director, about 15 seconds. Part (d) is, however, in use only for the time needed to determine translation information.

To use the translation field more efficiently, it was made common equipment, and with this arrangement less total equipment is necessary for an installation than would otherwise be the case. The individual equipment is now referred to as a "register" and the common equipment as the "translator."

The rest of this article describes the tubes used, the circuit principles adopted and typical circuit elements. In order to simplify this description, only typical values have been quoted, and all potentials are with respect to earth, except where otherwise stated.

† Messrs. Heron and Baker are Executive Engineers, E.-in-C.'s Office, Telephone Development and Maintenance Branch, and Mr. Benson an Assistant Engineer in that Branch.

¹ T. H. Flowers. "Introduction to Electronic Automatic Telephone Exchanges." *P.O.E.E.J.*, Vol. 43, p. 61 and p. 177; Vol. 44, p. 10.

COLD-CATHODE TUBES

General.

Two types of cold-cathode tube are used in the equipment, a three-electrode or triode tube, and a two-electrode or diode tube. Samples of both types are illustrated in Fig. 2. A diode

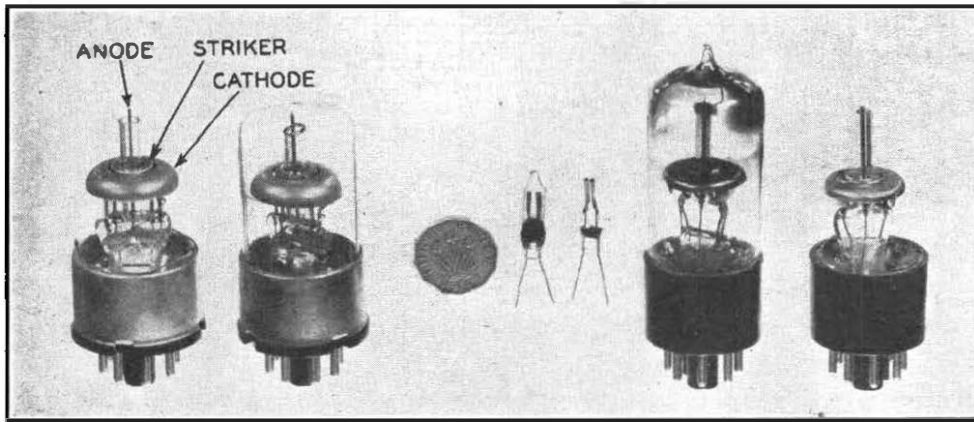

FIG. 2.—TYPICAL COLD-CATHODE TUBES; *Left and Right, TRIODES; Centre, DIODES.*

comprises an anode and a cathode in a glass envelope containing gas, usually neon, at a low pressure. The third electrode in a triode is known as the "striker."

Basic Operation.

Fig. 3 (a) shows the simplest cold-cathode circuit. When

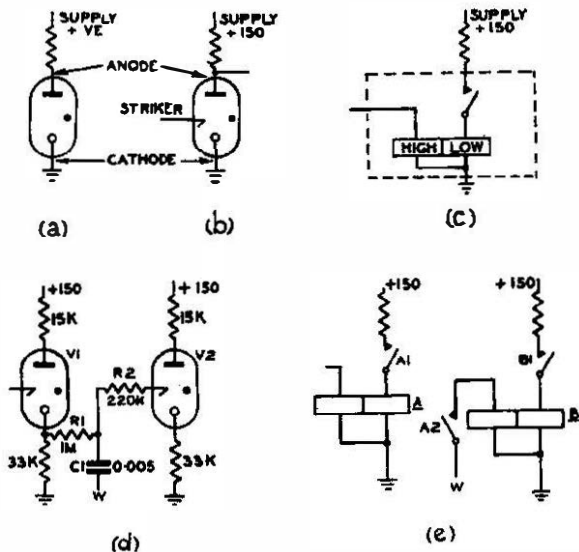

FIG. 3.—SIMPLE COLD-CATHODE CIRCUITS AND THE CORRESPONDING RELAY CIRCUITS.

the supply potential is low (say, below 40V) the tube is non-conducting because the gas in the tube acts as an insulator. If the supply potential is raised to a certain value known as the "breakdown" potential, the tube suddenly conducts (because the gas breaks down and becomes ionised) and a particular potential difference is developed between the cathode and anode. Within the range of currents at which the tube is operated, this potential difference is almost constant and is called the "stabilise" potential. The tube will remain conducting as long as current is supplied by the circuit, i.e. as long as the supply potential is above the stabilise potential.

The stabilise potential is always less than the breakdown potential and thus, if the supply potential is between these

two values the tube can be either conducting or non-conducting. If conducting, the tube can be "extinguished," i.e. switched to the non-conducting condition, by momentarily reducing the anode potential below its stabilise value. If non-conducting, the tube can be made to "strike," i.e.

switched to the conducting condition, by momentarily raising the anode potential above its breakdown value. The striker in a triode is introduced to provide an independent electrode which can be used to strike the tube, i.e. the gas can be ionised by striker-to-cathode breakdown.

For a typical triode, the anode breakdown potential is about 170V and the stabilise potential about 75V. Consequently, this tube is usually operated from a supply potential of 150V. Because the striker is placed near to the cathode (Fig. 2) the striker breakdown potential is low,

being about 70V.

The diode illustrated in Fig. 2 has a breakdown potential of about 70V and a stabilise potential of about 60V.

Cold-cathode Triode Circuits.

Fig. 3 (b) shows the simplest application of a triode. If the tube is non-conducting, the output from the anode will be at the same potential as the supply, i.e. +150V. If the striker potential is raised above +70V, the tube will strike and the output potential switches to the stabilise potential of +75V. This action of the cold-cathode triode is similar to that of the relay circuit shown in Fig. 3 (c), in which the relay operates via the high resistance winding and locks via its own contact to the low resistance winding. The analogy is more correct if a counter-E.M.F. battery of 75V is imagined to be in series with the locking circuit.

One tube can be used to control the striking of another tube by arranging the circuit as shown in Fig. 3 (d). In this circuit, two-thirds of the external resistance is connected between cathode and earth and one third connected between the anode and the supply potential of +150V. The cathode potential will be earth if the tube is non-conducting and +50V if the tube is conducting; (75V is lost across the tube and two-thirds of the remaining 75V appears across the cathode resistor). With both tubes non-conducting the striker of V2 will be at earth potential. A positive pulse of, say, 40V amplitude, applied to the lead W, will raise the potential of V2 striker momentarily to +40V, but this will not strike V2. If, however, V1 is conducting, then the striker of V2 is raised to +50V which, by itself, is unable to strike V2, but if the pulse is now applied to the lead W, the striker of V2 will be raised momentarily to a potential of +90V, causing V2 to strike and conduct. R2 in the striker circuit is necessary as a protective resistor.

Fig. 3 (e) shows a relay analogy of this arrangement in which V1 and V2 are represented by relays A and B respectively. Contact A2 controls the operation of relay B. Additional contacts on the A relay would make it possible to control the operation of other relays and in the cold-cathode circuit described, the equivalent of additional contacts can be obtained by teeing additional V2 circuits to the cathode of V1.

Fig. 4 shows how triode tubes can be arranged as a counter, and how one tube can be used to extinguish

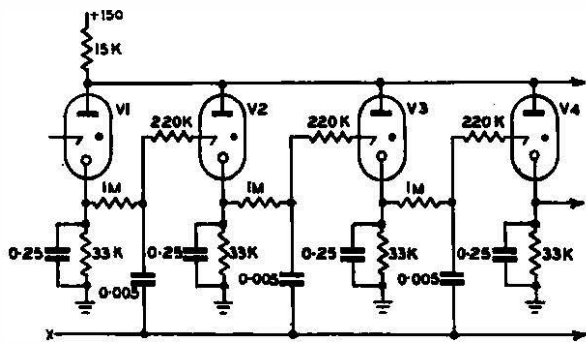

FIG. 4.—COLD-CATHODE TRIODES ARRANGED AS A COUNTER.

another. This is achieved by having a common anode resistor, and by shunting each cathode resistor by a capacitor.

Assume that V1 is the only tube conducting, then V2 will be the only tube with its striker at +50V, other strikers being at earth potential. If a 40V positive pulse is applied to the lead X, this will momentarily raise the potential of each striker by 40V, the striker of V2 will be raised to +90V and V2 will strike. Before V2 strikes, the cathode capacitor of V1 is charged to +50V, the anode will be 75V higher than this and therefore all anodes will be at a potential of +125V. When V2 strikes its anode potential will stabilise 75V higher than its cathode potential, which is earth; thus the potential of the common anode lead is reduced from +125V to +75V and, as the cathode capacitor of V2 charges up to +50V, the anode potential rises to the original +125V. When the anode potential fell to +75V, the potential difference between anode and cathode of V1 was reduced to 25V (+50V at the cathode and +75V at the anode), so that V1 ceased to conduct. This potential difference rapidly increases as the anode potential rises to +125V and the cathode potential dies away to earth. However, before this potential difference has had time to reach 75V (i.e. about four milliseconds), the gas in the tube will have had time to de-ionise so that the tube will remain in the non-conducting condition. It can be seen that after a suitable delay to allow various capacitors to charge to the new potentials, a further pulse applied to the lead X will strike V3 and extinguish V2. This arrangement is a "one up" chain counter, i.e. only one tube conducting at a time, and will count as many impulses as there are tubes in the chain (neglecting the first, or starting tube). The last tube can be connected back to the first tube to make the arrangement a ring counter. All the cold-cathode triode tubes in the translator, and nearly all in the register, are used in circuits which are similar in principle to this counter circuit. The counters operate at speeds up to 90 steps per second. This is nearly the maximum reliable speed possible with the tubes used, but recent tube developments show that very much higher counting speeds will soon be practicable.

Cold-cathode Diode Circuit.

Fig. 5 (a) shows a circuit in which this tube is used as a selective coupling element. The lead C is connected to a control potential such as that supplied by the cathode of a cold-cathode triode. The lead A is connected to a pulse supply which is to be controlled. The operation is very similar to the striking of a cold-cathode triode as already described, i.e. the control potential plus a pulse will ionise the gas and cause the tube to conduct but, in this case, only for the duration of the pulse, because the circuit is arranged so that neither the control potential nor the pulse magnitude by themselves can maintain current through the tube. While the tube is conducting, a potential difference is

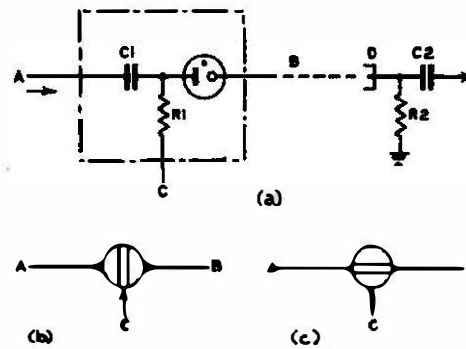

FIG. 5.—(a) GATE CIRCUIT USING A DIODE. (b) AND (c) SYMBOLS FOR CLOSED AND OPEN GATE, RESPECTIVELY.

developed across the cathode resistor R2 and this signal can be used in various ways, for example, to strike a cold-cathode triode. Since the diode is effectively a disconnection when de-ionised, a number can be joined together at the common point D shown in Fig. 5 (a). The diode, resistor and capacitor, each of which is very small, together form an electronic element similar to a single-contact high-speed relay. The element is not exactly equivalent, and it is usual to refer to it as a "gate." The gate is said to be closed when pulses will not pass from A to B (Fig. 5) and open when pulses will pass from A to B. Fig. 5 (b) and (c) show a convenient symbol for this simple gate circuit; the former shows a gate which is normally closed and the latter shows a gate which is normally open. It should be noted that this is not a standard symbol. Consideration is now being given to standard symbols for electronic circuits, and a symbol may be standardised, capable of being applied to all types of gate circuits.

HOT-CATHODE VALVES

The type of hot-cathode valve used is shown in Fig. 6,

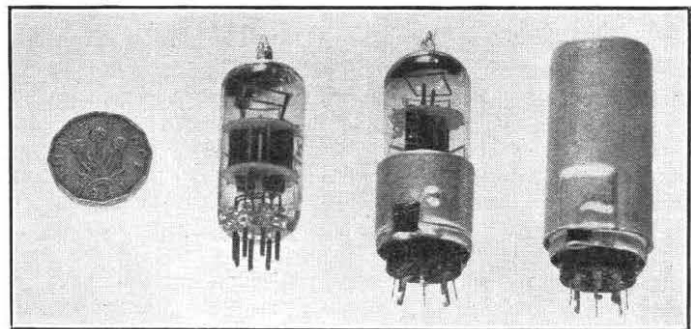

FIG. 6.—HOT-CATHODE VALVE OF B7G TYPE.

which also shows the socket and screening can. The valves are standard miniature triodes and pentodes such as are normally used in radio and transmission equipment, but the method of use in the present equipment is quite different.

Circuit Principles.

If the grid of a triode is held sufficiently negative with respect to its cathode (say, 10V), the valve is "cut-off," no current flows through the anode resistor, and the anode potential is the same as the supply potential, e.g. +100V, as shown in Fig. 7 (a). Alternatively, if the grid is connected to a positive potential via a resistor R2, as shown in Fig. 7 (b), the valve conducts, and it behaves as a simple resistor connecting cathode to anode. The value of this equivalent resistance varies with the value of the positive potential applied to the grid of the valve. With the grid positive to cathode, grid current flows because the grid and cathode act as a diode. If a current-limiting resistor R2

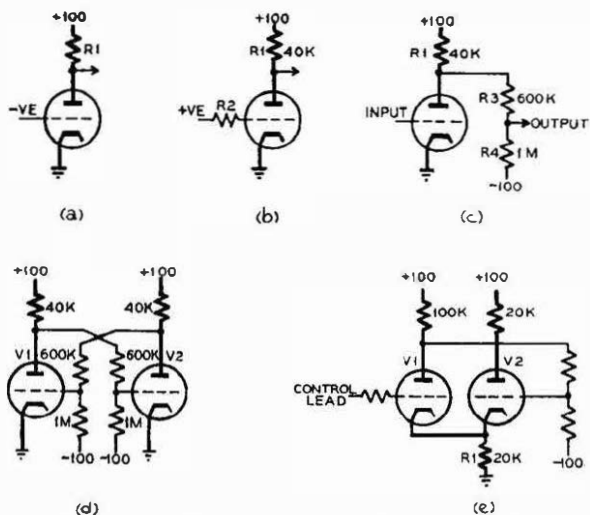

FIG. 7.—CIRCUIT ELEMENTS USING HOT-CATHODE VALVES.

(about half a megohm in value) is inserted in the grid lead as shown in Fig. 7 (b), the diode action prevents the potential at the grid of the valve rising more than a fraction of a volt positive to cathode even though the potential applied to R2 is varied between, say, +5 and +100V. For the particular types of triode valve used in the experimental equipment the equivalent cathode-to-anode resistance, when controlled by R2, is about 10,000 ohms. Using this value of resistance, the valve and anode resistor together may be treated as two resistors in series, i.e. as a simple potential divider and, for the values given, the anode potential is +20V. It follows that if the potential applied to the grid resistor R2 is held either below -10V or above +5V, the anode potential will be either +100 or +20V, respectively. By using hot-cathode valves in this way, i.e. as "on-off" switches, circuit operation can be made largely independent of valve characteristics.

The swing of anode potential, e.g. +20 to +100V, represents the output of the switch. This output may be used to actuate another similar switch, but the input to the grid of the second switch must swing between at least -10 and +5V. It follows that the anode of the first valve cannot be connected to the grid of the second valve without introducing a biasing potential. One typical arrangement is shown in Fig. 7 (c), in which a negative supply of 100V is needed. Resistors R3 and R4 together form a potential divider and are so proportioned that the potential of the output lead swings between -25 and +22V as the valve switches from "on" to "off." Resistors R3 and R4 are high in value compared with R1. This permits the anode of the switching valve to control several other switches in parallel, each with its own potential divider. Moreover, because of its high value, R3 can provide the grid current limiting action of R2 in Fig. 7 (b).

"Trigger" Circuits.

In Fig. 7 (d) two typical "on-off" switches are connected in series, with the output of the second switch connected back to the input of the first switch. Each valve switches the other and without any external connections the circuit will be in one of the two stable conditions:

- (a) V1 conducting, V2 non-conducting,
- (b) V1 non-conducting, V2 conducting.

The circuit can be switched from one condition to the other by forcing the non-conducting valve to conduct or by forcing the conducting valve into non-conduction; in either case, the circuit "triggers" to the other condition in a very short time (about one micro-second), therefore the duration of the

control signal can be extremely short. This circuit element, which was first described by Eccles and Jordan in 1919, is useful where a pulse on one control lead is required to "operate" the element and a pulse on another control lead is required to "restore" the element. The circuit can be modified and adapted in many ways to give a wide range of facilities.

Another trigger circuit with two stable conditions, but having different characteristics is shown in Fig. 7 (e). If the control lead is held at earth potential, then V1 will be cut off, and V2 will conduct. The cathode resistor R1 causes the cathode to assume a potential of +40V, the anode of V2 is at +60V, and the remaining 20V is developed across the valve resistance of 10,000 ohms. Since the cathodes of V1 and V2 are connected together, the grid of V1 is 40V negative with respect to its cathode so that V1 is cut off as stated. The control lead can be held at any potential lower than +37V, without altering this "initial" condition of the trigger. If, however, this potential is raised to +37V, i.e. the grid -3V with respect to its cathode, then V1 starts to conduct, and the circuit triggers to the other condition with V1 conducting and V2 cut off. The anode resistor of V1 is higher in resistance than that of V2; therefore the current through the common cathode resistor R1 is less than with V2 conducting and consequently, the cathode potential is reduced to +15V. The circuit will remain in this "reversed" condition as long as the control lead is held above +10V, but at +10V V1 cuts off and the circuit triggers back to its initial condition. Thus, having raised the potential of the control lead to +37V, in order to operate the trigger, this potential must be reduced by at least 27V (down to +10V) in order to restore the trigger. This difference between the operate and restore voltages is called the "backlash" voltage. The trigger action is independent of the rate at which the control voltage passes through the trigger potentials of +37 and +10V. This circuit can be arranged to function over a range of backlash and trigger voltages.

Gate Circuits.

It has already been explained that a simple gate circuit is one in which a signal is passed from the input to the output under the control of a third connection. Fig. 8 (a)

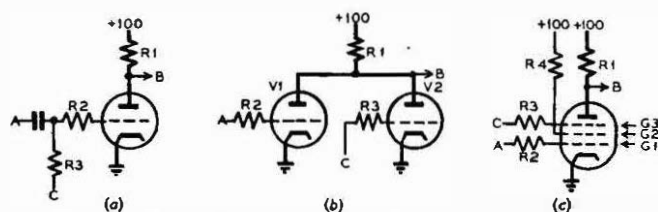

FIG. 8.—GATE ELEMENTS USING HOT-CATHODE VALVES.

shows one of many ways in which a triode can be used for gating. If the potential of the control lead C is -10V and a 20V positive pulse is applied to the input A, the valve conducts and the output is switched to its lower potential for the duration of the pulse. Thus, a negative signal is produced at the output B. If the potential of the control lead C is made -30V or lower, the gate is closed, i.e. a 20V positive pulse applied to the input A cannot make the valve conduct. The same circuit arrangement can be used to gate negative signals if the control lead C is held positive so that the valve is normally conducting. Thus, with the control lead at +5V a 20V negative pulse on the input gives a corresponding positive signal on the output, but if the control lead is held above +25V a 20V negative pulse on the input has no effect.

Fig. 8 (b) shows a gate element in which the input and

circuit can be arranged to meet as wide a range of impulse ratios and impulse speeds as is required.

Reference has been made to the fact that hot-cathode valve circuits can be switched in an extremely short time. This feature produces difficulties when valve circuits are associated with electro-mechanical equipment. This is because the back E.M.F.s produced by magnets and relays releasing, frequently as high as 1,000V, are transmitted around an exchange by the wiring. The five wires con-

necting an A-digit selector to the electronic register conduct these signals into the register, and the signals cause mis-operation unless the electronic circuits are protected. Fig. 1 (a) shows how the electronic equipment has been isolated from the exchange equipment at the conversion relay set. The one "through wire" is filtered at this point, the filter comprising capacitor C1 and resistor R2 in Fig. 9.

(To be continued)

A New Principle for Obtaining Improved Speech Immunity with V.F. Signalling Receivers

Introduction.

THE design of a voice-frequency signalling system for trunk circuits may be considerably affected by the speech-immunity characteristics of the associated V.F. signal receivers. For conventional design receivers these are mainly determined by the signalling frequency, the operate bandwidth and the efficiency of the guard feature. A reduction in the operate bandwidth gives some increase in speech immunity at the expense of adverse signal impulsing characteristics and an increased operate time of the receiver and makes the receiver more critical in operation. Increasing the guard efficiency gives some improvement in speech immunity, but renders the receiver more liable to signal interference. The design, therefore, becomes a compromise and adequate speech immunity is generally obtained by recognising only those signals which operate the receiver for a predetermined, and often rather long, period. This affects the design of the system and makes the discrimination of signals on a time-duration basis unwieldy. 2 V.F. systems overcome some of these difficulties, but even with a 2 V.F. system speech immunity of the V.F. receiver is still important.

A New Means of Signal Discrimination.

An additional means of discriminating between speech and V.F. signals has now been investigated, and is based on the following signal and speech characteristics:—

Pulses of signal of frequency f are always preceded by at least a few milliseconds period in which no frequencies capable of energising the guard circuit are present, and, apart from the introduction of very short transients of other frequencies at the commencement of the pulses, are composed entirely of signals of frequency f ; whereas,

Speech signals of frequency f (above 2,000 c/s) are usually preceded or accompanied by signals of another frequency. It is possible that signals of frequency f will rarely occur at the commencement of a speech sound without other guard frequency signals being present.

Experimental V.F. signal receivers were designed to test the validity of this assumption. Their operation depends on the fact that, whilst it is essential that the guard effect ceases as soon as a signal (speech or of frequency f) ceases, it remains at the maximum value attained as long as the input to the receiver (signal or speech) is above the minimum signal level which operates the receiver. The guard effect is derived from a charge on a capacitor and, provided that the transient guard signals at the commencement of a signal impulse are not allowed to charge the guard capacitor excessively, the operation of the receiver to signal pulses of frequency f is unaffected by preventing the guard capacitor discharging throughout the signal period. When speech signals are applied to the receiver, however, the guard circuit capacitor becomes charged to the maximum guard voltage derived from any part of those speech signals and maintains that voltage until the level of the speech falls below the receiver operate level. If the receiver is of the

limiter type in which the rectified guard and signal voltages are independent of the level of the input to the receiver over a wide range of signal levels, and the guard voltage at guard frequencies is as large as the signal voltage at frequency f , then any guard frequency signal of the limiting level or above will prevent a following portion of speech signal from operating the receiver even if that signal changes to one of frequency f of large amplitude. This may be of particular interest if F.M. picture telegraph signals are likely to be applied to the receiver.

The Discharge Path of the Guard Circuit Capacitor.

The guard circuit capacitor is charged through a thermionic diode so that it cannot discharge through the back impedance of the diode. Its discharge circuit consists of the anode-cathode impedance of a triode, the control grid of which is at cathode potential in the quiescent state. All speech and other signals received are rectified and applied to a resistor-capacitor combination with a time-constant of 3 mS in series with the control grid to bias it negatively, so that if the signals are above the receiver operate level this negative control grid voltage makes the anode cathode circuit completely non-conducting. The guard circuit capacitor now holds its charge until the signal ceases. As soon as this occurs, or the signals fall below the level required to maintain the valve "cut-off," the capacitor is discharged. Complete discharge of the guard circuit capacitor is then obtained in 5 mS after the cessation of a signal.

Speech Imitation Test Results.

Extensive speech immunity tests have been carried out on experimental 2,280 c/s receivers having this long duration guard time-constant feature, using similar-type receivers, but with a fixed guard time-constant of 20 mS as controls. The receivers had operating bandwidths from ± 35 c/s to ± 120 c/s and would operate satisfactorily with a -15 db. level input signal in the presence of interference ranging from -35 db. to -22 db. level, depending on the guard coefficient.

The relative improvement in speech immunity obtained using the new technique was greatest for narrow bandwidth receivers with a large guard coefficient, when less than 0.2 speech operations per speech hour exceeding 10 mS were obtained, but a large improvement was obtained under all conditions. A receiver with a bandwidth of ± 120 c/s operating with a -15 db. input signal with only 2 mS signal distortion in the presence of -26 db. interference, had approximately 0.5 speech operations per speech hour exceeding 20 mS. Such a receiver operates within 3 mS and recovers in 5 mS, and so can be used to receive interrupted signals of 100 i.p.s. or less for signal discrimination purposes and then gives complete speech immunity. A simple relay circuit designed to operate on two consecutive impulses (50 i.p.s.) was unoperated by speech during a period of more than 100 speech hours.

L. E. R.

Detection of Defective Connections in Line Transmission Equipment

N. W. LEWIS, Ph.D.(Eng.), M.I.E.E.†

U.D.C. 621.317.333.4:621.315.682:621.392

The general requirements for testing-apparatus used in the vibration-testing method of locating defective joints and contacts in line transmission equipment are stated. The principles of various possible types of tester are given, and their relative merits discussed, with the conclusions upon which have been based the design of two types of tester intended for field use.

Introduction.

THE adoption of the vibration-testing technique for locating defective connections in line transmission equipment, as described by H. G. Myers,¹ has required the development of special testing apparatus.

Early applications of the technique relied upon the aural observation of a low-level sinusoidal test signal passed through the equipment under test and made audible on a loudspeaker, using some form of frequency translator if necessary. Such an arrangement was relatively insensitive and suffered from the practical disadvantage of continuous sound from the loudspeaker. This was replaced, for temporary use in the field, by an elementary form of the "demodulator" type of tester, based on the principle referred to later and constructed from readily available components.

The development of more sensitive testers covering a wider range of frequency was clearly desirable, and this article records the general considerations which led to the design of two types of tester which it is intended to describe in detail in a later article.

In this article, the term "connection" is used in a wide sense, including the pressure contacts of such items as keys, switches, potentiometers, plugs and jacks, U-links, relays and valve sockets, as well as soldered joints.

GENERAL REQUIREMENTS

Frequencies of Test Signals.

Only single-frequency test signals are considered in this article. Although a single frequency is obviously not ideal for testing a unit such as a filter or equaliser, the provision of double- or multi-frequency test signals for general use in the field is not considered justified in view of the consequent complexity of the testing apparatus. It seems preferable to repeat vibration tests at additional frequencies when the adequacy of a single-frequency test is doubted.

For testing audio-frequency equipment, the frequency of the test signal must be within the range 300-3,400 c/s. The choice depends upon the type of tester, as discussed later, but it may be mentioned here that the range below 1,000 c/s is best avoided because it generally contains the major components of valve microphonic noise.

For testing the transmission paths of carrier-frequency equipment, at least three frequencies are necessary to cater for the "group" bands of 12-60 and 60-108 kc/s, and the "supergroup" band of 312-552 kc/s. The arithmetic mean frequencies, namely 36, 84 and 432 kc/s, have been chosen as convenient. For testing carrier-frequency generating equipment, the normal outputs are regarded as equivalent to test signals; the tester must therefore be able to receive frequencies up to about 4 Mc/s.

Sensitivity.

The essence of the vibration method of testing is that it aims at detecting all varying or unstable connections on the hypothesis that almost any perceptible variation in the

resistance of a connection under vibration indicates a fault condition which may develop if allowed to remain un-cleared. No single criterion as to what constitutes a significant variation can be applied to all of the many types of joint and contact found in transmission equipment, but it is considered that variations of the order of 0.01 ohm, or more, should be regarded as significant in most cases.

There is no difficulty in designing a tester capable of indicating short-period variations of 0.001 ohm, or even less, in a single connection, but the present need is for testers suitable for checking the through transmission paths of complete units of equipment, such as amplifiers. It would, of course, be quite impracticable to connect a tester to each individual joint and contact when overhauling equipment in the field.

The elementary "demodulator" form of tester previously referred to is capable of indicating transmission variations down to about 0.1 db. Such an amount corresponds to that caused by the insertion of 14 ohms of series resistance in a 600-ohm circuit, or 1.8 ohms in a 75-ohm circuit. Bearing in mind that the circuit impedances of transmission equipment range up to a megohm, or more, and that many important connections are remote from the main transmission paths, it would appear at first sight that testers of the type under discussion are rather unpromising. Nevertheless, it is a fact that the elementary testers have already enabled very large numbers of defective connections to be detected and cleared.

On the foregoing considerations it was decided initially to base the designs of new testers on a minimum requirement that they must give clear indications of variations down to 0.01 db. with a target of 0.001 db. Compared with the 0.1 db. sensitivity of the existing detector, these figures represent improvements of 20 and 40 db. respectively. Later, however, trials showed that it is inadvisable to provide a sensitivity much better than 0.01 db. for general work in the field because of the possible misleading effects of microphonic noise produced, during vibration-testing, by such items as quartz crystals and iron-cored transformers and inductors, even when these are free from faults.

It may be remarked here that, in general, the detection of defective connections depends as much upon phase variations as upon amplitude variations of the test signal, but it is convenient to compare testers in terms of their sensitivities to amplitude variations alone.

Another factor bearing on the question of sensitivity is the fact that defective connections under vibration may give rise to variations of only very short duration. Reliable information on the subject not being available, it was arbitrarily decided to aim at obtaining clear indications of variations subsisting for periods at least as short as one millisecond. This means that the effective bandwidth of the testers must be at least 500 and preferably 1,000 c/s.

Levels of Test Signals.

Experience with the vibration-testing method has shown it to be essential that the final indicating device shall be some form of loudspeaker, so that the operator can dis-

† Senior Principal Scientific Officer, Research Station.

¹ P.O.E.E.J., Vol. 42, p. 189.

tinguish aurally the amplitude and time characteristics of intermittent connections and so be enabled to correlate transmission variations with movements or vibrations of parts of the equipment. This rules out testers in which the indicating device is a lamp, cathode-ray tube, buzzer or equivalent, but not necessarily those in which, for example, a single sudden change of level causes a short duration "chirping" or "ringing" sound from the loud-speaker.

The main design problem is that of achieving a satisfactory signal/noise ratio. A variation of 0.01 db. in a test signal is equivalent to the addition or subtraction of another signal of the same frequency but nearly 60 db. lower in level. For 0.001 db. variation, the equivalent "fault signal" is nearly 80 db. below the test signal. The background noise in transmission equipment may consist of a medley of speech-babble, tone and other interference due to crosstalk and battery supply couplings, together with valve microphony and inherent random noise. In some units, the total noise power in a bandwidth of 1,000 c/s may be of the order of 80 db. below the normal channel test level. Assuming that a minimum signal/noise ratio of 10 db. is necessary for satisfactory operation of a tester, it therefore appears that the detection of 0.01 db. variations requires the minimum level of the test signal to be about -10 db. relative to the channel test level. For 0.001 db. variations, the minimum level would be about +10 db.

An opposing requirement arises from the desirability of transmitting the test-signal through the equipment under test at a low level to avoid the electrical breakdown of tarnish and other alien films in connections. The great majority of such films are believed to require a peak potential difference greater than 0.1V to cause breakdown. For this reason, a test signal of -20 db. relative to the channel test level is generally assumed to be desirable: at a zero-level point, it corresponds to 0.11V peak in a 600-ohm circuit, or 0.04V peak in a 75-ohm circuit. This low level is undoubtedly essential when, for example, the long-term stability of undisturbed equipment is checked with a recording instrument. In vibration testing, however, the disturbance of the equipment is expected to be sufficient to leave only a small probability that a defective connection will fail to indicate its presence after being "cohered" by a relatively high-level test signal.

In view of the importance of high sensitivity, it is concluded that the best overall results will be obtained when the level of the test signal is about equal to the normal channel test level. If further experience should prove this conclusion wrong, it may be necessary to double the vibration tests, making a first test with low level and low sensitivity, and a second with high level and high sensitivity.

METHODS OF DETECTION

In this section are given the principles of three methods, distinguished by the terms "bridge," "demodulator" and "sideband." Other methods, e.g. a non-linear bridge, have been suggested but are not considered worthy of further study at present.

Bridge Method.

This is based on the "bridge" principle of opposing the test signal output of the equipment under test with another signal which is initially of equal amplitude and phase, so that the resultant is zero. Any subsequent unbalance caused by a variation of attenuation or phase-shift in the equipment under test gives rise to an output from the bridge which can be made audible on a loudspeaker.

Fig. 1 illustrates the principle as applied to audio-frequency testing. The test signal from an oscillator is

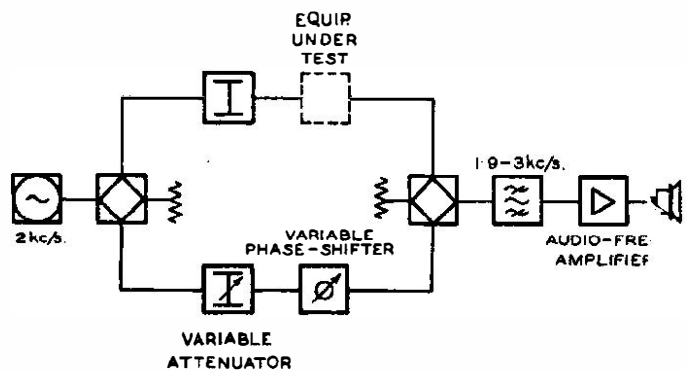

FIG. 1.—PRINCIPLE OF BRIDGE METHOD FOR AUDIO-FREQUENCY TESTING.

divided between two paths, one through the equipment under test and the other through a variable attenuator and a 360° variable phase-shifter. The paths are then combined and the resultant signal passes through a band-pass filter and high-gain amplifier to a loudspeaker. At the commencement of a test, the attenuator and phase-shifter have to be adjusted to give a substantially zero resultant signal, but this operation can be carried out quite quickly if means are provided for approximately equalising the attenuations of the two paths before phase-balancing is begun.

The band-pass filter is necessary to reduce background noise and harmonics of the test signal; its effective bandwidth, as already stated, should be of the order of 1,000 c/s. To obtain the optimum signal/noise ratio under average conditions, the test signal frequency should be located near one end of the pass-band to give an "asymmetric-sideband" effect. The main considerations in the choice of frequency are (a) that the range below 1,000 c/s should be avoided because it contains the major components of valve microphonic noise, and (b) that combined loudspeaker and aural sensitivity characteristics show an advantage in placing the test signal and the chosen sideband in the range 2,000-4,000 c/s. In the diagram, the oscillator frequency is shown as 2 kc/s and the filter pass-band as 1.9-3 kc/s, the upper sideband thus being effective. A lower-sideband alternative, however, would be given by an oscillator frequency of 3.2 kc/s (this particular figure is of interest because it is used in certain circuit monitoring applications) with a filter pass-band of 2.2-3.3 kc/s.

A point of importance is that the oscillator should have a high short-term stability of frequency to prevent the bridge from drifting out of balance during the period of a test. This requirement arises because practicable forms of variable phase-shifter are frequency-dependent to some extent. However, if it is convenient to divide the phase-shifter into two parts (as may be desirable to obtain separate "coarse" and "fine" controls when the simple resistance-capacitance type is used), some advantage may be gained by placing one part in each path of the bridge. The stability requirement may then be relaxed somewhat because the phase-shift in equipment under test is commonly quite small, so that both phase-shifters can be set to about the same angle and tend to be affected equally by changes of frequency.

For carrier-frequency testing, some form of heterodyne detector could be added to a carrier-frequency bridge to make the resultant signal audible, but this arrangement is likely to be unsatisfactory because of phase-shifts resulting from hand capacitance effects during operations on the equipment under test. The difficulty may be overcome by the use of an amplitude-modulated test signal. A convenient practical arrangement might be based on the audio-frequency set merely by (a) preceding the equipment under test by an elementary form of modulator fed with the

desired carrier frequency, and (b) succeeding it with a simple detector. The bridge will respond to variations in the envelope of the test signal but will be relatively insensitive to phase-shifts of the "carrier" within the envelope.

Demodulator Method.

First considering carrier-frequency testing, the principle of this method is that the test-signal output from the equipment under test is passed through a suitable "demodulator" to a loudspeaker so that any modulation of the signal caused by a defective connection can be made audible. The underlying assumption is that, when a connection varies under vibration, the rate of change of resistance is sufficiently high for the spectrum of the modulation envelope to contain substantial components in the audio range, i.e. for the variations to be audible as a "crackle" or series of "clicks."

Fig. 2 illustrates the application of the principle to

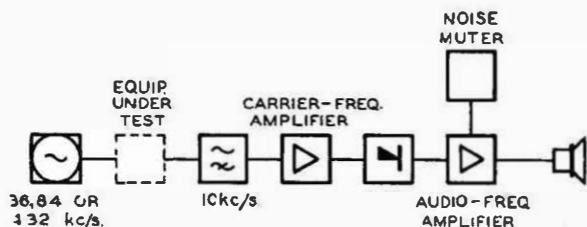

FIG. 2.—PRINCIPLE OF DEMODULATOR METHOD FOR CARRIER-FREQUENCY TESTING.

carrier-frequency testing. The "fault-modulated" test-signal output from the equipment under test passes through a filter and carrier-frequency amplifier to a detector, from which the audio-frequency output passes through an audio-frequency amplifier to a loudspeaker. The detector must, of course, include an elementary low-pass filter to suppress the carrier-frequency products of detection.

The input filter, shown in the diagram as a 10 kc/s high-pass filter, serves to suppress any audio-frequency noise emanating from the equipment under test. A better signal/noise ratio would theoretically be obtained if it were a band-pass filter having an effective bandwidth of about 1,000 c/s., with the test-signal frequency located near one end of the pass-band. Fortunately for the simplicity of the arrangement, it has been found in practice that such band-pass filters offer negligible advantage over the high-pass filter when testing normal carrier equipment. Further, the filter need not be provided as a separate entity if the carrier-frequency amplifier is designed to have sufficient loss at audio frequencies.

A noise-muting circuit of the short time-constant type, preferably in the output circuit of the audio-frequency amplifier, is desirable to reduce or eliminate the usual continuous background noise, which tends to be disturbing to the operator. An adjustable threshold is necessary to cater for the widely varying conditions likely to be met in practice. Loss of sensitivity due to excessive muting may be guarded against by providing means for checking the overall sensitivity immediately before each vibration test is begun. It is to be noted that although a noise-muter gives a very great improvement of the signal/noise ratio in the loudspeaker, its use does not permit of any substantial reduction of the signal/noise ratio at the output of the equipment under test, i.e. it does not enable the level of the test signal to be reduced.

For audio-frequency testing, the arrangement of Fig. 2 could be modified by (a) reducing the oscillator frequency, (b) lowering the cut-off frequency of the high-pass filter to about 2,000 c/s, (c) replacing the carrier-frequency amplifier by an audio-frequency amplifier and (d) inserting a low-

pass filter between the detector and the final audio-frequency amplifier.

The main function of the low-pass filter is to introduce large attenuation at the test-signal frequency and its harmonics so that the loudspeaker is normally silent. Discriminations of the order of 90 db. against the test-signal frequency and 70 db. against the second and third harmonics are required if a sensitivity of 0.01 db. is to be achieved. The filter design is obviously facilitated by choosing a relatively high frequency for the test signal; again, as for the bridge method, 3,200 c/s is a convenient value. It will be appreciated that any practicable design of such a filter requires the imposition of a high-stability requirement on the oscillator frequency.

Sideband Method.

This method, applicable only to audio-frequency testing, is similar to the demodulator method in that any modulation of a test signal by a defective connection is made audible. The principle, illustrated in Fig. 3, is that the

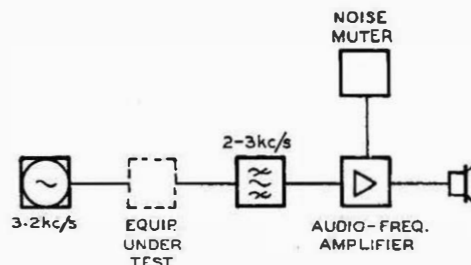

FIG. 3.—PRINCIPLE OF SIDEBAND METHOD FOR AUDIO-FREQUENCY TESTING.

"fault-modulated" test signal is passed through a filter which removes the test signal itself and one sideband, but allows the other sideband to proceed through an audio-frequency amplifier and be heard directly on a loudspeaker.

The main function of the band-pass filter is identical with that of the low-pass filter in the demodulator method, and the choice of frequency is governed by the same considerations. Assuming a test signal frequency of 3,200 c/s, the filter should provide a discrimination of the order of 90 db. against this frequency, and 70 db. against its second and third harmonics. The lower attenuating region of the filter characteristic, i.e. below about 2,000 c/s, is required to discriminate against valve microphonic noise. Again, the oscillator should possess a high short-term stability.

It may be of interest to mention that, if the noise-muter is omitted from the arrangement shown in the diagram, defective connections under vibration generally cause the loudspeaker to produce sounds reminiscent of a hammer on an anvil. The effect of a short time-constant noise-muter is to remove much of the "ringing" quality and make the sounds similar to those obtained with the demodulator method.

COMPARISON OF METHODS

The chief point of difference is that, on the one hand, the bridge method is responsive to slow as well as fast variations in the equipment under test and gives a "permanent" indication of a single change, while, on the other hand, the demodulator and sideband methods are responsive only to fast variations and give only a "transient" indication of a single change. In this sense, the bridge method may be said to offer the greatest possible sensitivity, which is of obvious advantage when equipment is to be tested as critically as possible.

Sensitivity to slow variations must, however, be reckoned as a disadvantage under some conditions of use. For example, the vibration-testing of an amplifier not having

a high degree of negative feed-back would entail frequent re-balancing of the bridge to compensate for small changes of gain caused by power supply and "warming-up" variations or by the mere extraction and re-insertion of a valve. Further, the testing of such an item as a gain control switch would require a separate balancing operation for every setting.

For carrier-frequency testing, the foregoing considerations make it clear that the demodulator method is preferable for general work in the field, its lack of sensitivity to slow variations being outweighed by the fact that it requires no critical adjustments. A further point in its favour is its convenience for testing carrier-frequency generating equipment, a facility impossible to provide with the bridge method.

For audio-frequency testing, the bridge method is

similarly not recommended for general work in the field, but there still remains a choice between the demodulator and sideband methods. These are practically identical in performance, however, and the sideband method is thus naturally preferred because of its relative simplicity.

CONCLUSIONS

The general requirements for testing apparatus used in the vibration-testing method of locating defective joints and contacts in line transmission equipment have been stated. The principles of three types of tester have been given, and their relative merits for field work compared. The results have led to the practical realisation of a demodulator-type tester for carrier-frequency equipment, and of a sideband-type tester for audio-frequency equipment. It is intended to describe the details of these sets in a later article.

Book Reviews

"Voltage Stabilisers." F. A. Benson, M.Eng., A.M.I.E.E., M.I.R.E. Published by "Electronic Engineering." 125 pp. 97 ill. 12s. 6d.

The adequate stabilisation of the output voltage of a power unit which is supplied from the A.C. mains and has to feed electronic equipment, is a problem widely met, particularly in telecommunications, medical physics and the design of electronic instruments. Satisfactory engineering solutions are not easily found, however; few descriptions exist, for instance, of the deficiencies of the key components used to provide the reference voltage.

The monograph goes a long way to filling what was becoming a serious gap in the literature. It pays most attention to the properties of glow discharge tubes and to stabilisers using them. It describes the simplest circuits in which the load shunts the tube, and many of the more complex circuits using series and shunt valves to increase the range of output current over which stabilisation within some small range of voltage is assured. The attention paid to magnetic saturation and to the use of the non-linear relationship between current and voltage of thermistors, lamps and silicon carbide is much less without, however, being merely introductory. Nearly 300 references are quoted; they are probably the best collection on the subject.

J. R. T.

I.P.O.E.E. Library, No. 1972.

"Electromagnetic Waves and Radiating Systems." E. C. Jordan. Published by Prentice-Hall, New York, and Constable. 710 pp. 284 ill. 32s. 6d.

The general plan of this book is the familiar one of an introduction via electrostatic and magnetic field theory, the development of Maxwell's equations and their application to the propagation of electromagnetic waves in free space and in guiding structures such as transmission lines and waveguides. The directional and impedance characteristics of dipole and multi-element aerials, and travelling-wave (long-wire and rhombic) aerials are discussed, also the synthesis of aerials to give prescribed radiation patterns by means of Tchebyscheff approximations. Radiation from electromagnetic horns is analysed in terms of Fraunhofer and Fresnel diffraction theory, and Babinet's principle is applied to the study of slot aerials. Finally, the main characteristics of ground-wave and tropospheric propagation, and sky-wave propagation via the ionosphere, are surveyed.

The treatment of the subject is mainly theoretical and analytical; the material is well organised and clearly presented. Perhaps the main criticism of this book from an engineering standpoint is the academic approach to the subject; however, it is well suited to the needs of graduate and post-graduate students taking a telecommunications course, and engineers requiring a reference book for fundamental theory.

W. J. B.

"Applied Electricity." Edward Hughes, D.Sc., Ph.D., M.I.E.E. Longmans, Green & Co. 412 pp. 10s. 6d.

This is a text book for students preparing for the Ordinary National Certificate in Electrical Engineering and examinations of similar standard. The author starts with an outline of the fundamental properties of magnetic materials, magnetic circuits and electrostatics, and follows with a description of simple D.C. generator and motor theory. The next chapter is on single-phase circuits and their analysis by vectorial methods. After an introduction to 3-phase circuits, he deals with power transformers, alternators, the concept of the rotating magnetic field and induction motors, closing with chapters on thermionics—valves and metal rectifiers—and on the use of the operator "j" in solving circuit problems. A summary of essential formulæ is given at the close of each chapter followed by a long list of examples, to which answers are given at the back of the book.

For the student commencing a career in power engineering this book can be recommended for its clear, concise presentation and up-to-date detail. Telecommunication students will find it a valuable "background" book which contains much that it would be to their advantage to learn.

C. F. F.

"Television Receiving Equipment." (Third Edition). W. T. Cocking. Iliffe. 375 pp. 283 ill. 18s.

Mr. Cocking's book is almost too well known to need any introduction. Since it was first published in 1940, it has come to be regarded as the standard work on British television receiver practice and the high standard set earlier is maintained in this, the third edition. A considerable amount of additional information is now included and the book is presented with an enlarged format.

After describing briefly the general principles of television and the form of the British standard waveform, Mr. Cocking proceeds to deal in detail with the various parts of a television receiver, explaining the function of each and the alternative circuits or methods that can be used. No less than one-third of the book is devoted to synchronising signal separation, time bases and deflection means; and rightly so, for it is mainly in these elements that a television receiver differs from a normal sound set. Synchronising signal separation, in particular, is a detail that can easily mar the performance of a receiver that is otherwise very good, and it is perhaps a little surprising that no mention is made of frame signal separators employing delay lines, for they have been found to give by far the best interlace performance. However, this small omission may be forgiven in view of the general excellence of the book, one praiseworthy feature of which is the relegation of most of the mathematical material to appendices. Here it is readily available for the seeker after detail, while leaving the main body of the text unencumbered for those with a more general interest.

T. K.

Test Equipment for the Teleprinter Automatic Switching System

A. E. T. FORSTER, A.M.I.E.E.†

U.D.C. 621.394.324: 621.394.65

A range of test equipment has been developed for maintenance of the Teleprinter Automatic Switching System and the units concerned are briefly described by the author, attention being drawn to further testing requirements which will have to be met as the system expands.

THE opening of the first stage of the Teleprinter Automatic Switching System¹ in October, 1950, required, as a part of the development programme, the production of a range of test equipment specifically designed for the maintenance of the switching centre and station apparatus. Although, in the normal course of development, the production of test equipment often lags behind the system proper, the importance was recognised of having adequate testing facilities available at the opening, and every effort was made to achieve this. For acceptance testing, use was made of the maintenance testers wherever possible.

The following description covers the testers in the form in which they were introduced and does not include improvements which are being considered as a result of the experience gained to date.

Relay Timing Tester.

In the Teleprinter Automatic Switching System, testing facilities have been provided to enable relay timings to be maintained within well-defined limits. By so doing it is possible to ensure that the circuits will not fail due to a combination of adverse deviations within specified tolerances. A relay timing tester, enabling relays to be adjusted to give the requisite timing performance, is provided at each switching centre. These testers are not provided at teleprinter stations and special arrangements have been made for the centralised maintenance of position relay sets.

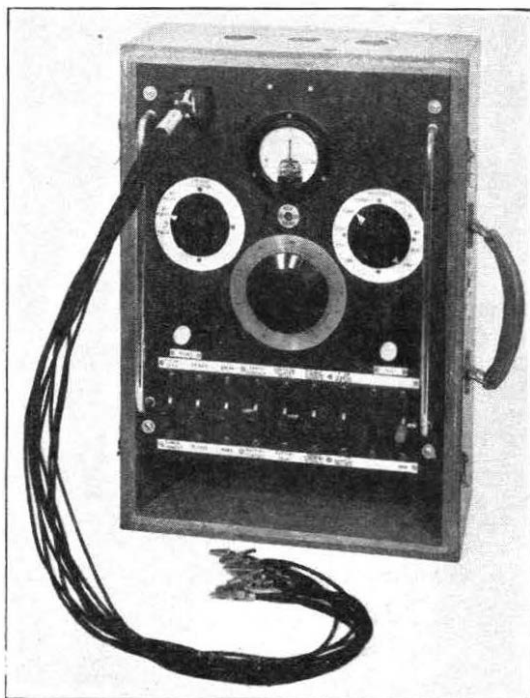

FIG. 1.—THE RELAY TIMING TESTER.

The relay timing tester, which is portable, is shown in Fig. 1, and for its operation requires a power supply which may be either dry batteries or the 80V or 50V switching centre battery supply. Connection with the circuit under test is by means of leads terminated in clips. The tester is arranged to measure operate and release lags with the various contact arrangements and coil energising conditions met in practice. Four timing ranges, 0-100 mS, 0-500 mS, 0-2 secs, and 0-5 secs, are provided, and can be selected by means of a rotary switch. A facility is also provided whereby the first, second or third pulse in a train of either single-current or double-current pulses may be selected and timed.

The circuit is a conventional timing bridge employing a fixed resistor-capacitor series combination as the timing element, a preset resistive potentiometer to produce the comparison voltage and a centre-zero meter as the detecting device. A potentiometer (Timing Scale), calibrated in milliseconds, applies a precharge to the capacitor and so determines the timing interval required to produce the balance potential on the capacitor. To provide the pulse measurement facility a small relay group selects either the first, second or third pulse in a train according to the setting of the 3-position "Impulse Selection" switch. The relays used are the high-speed type to minimise errors.

Engineering Control Board.

To provide test access to the lines connected to a switching centre an Engineering Control Board (E.C.B.) is

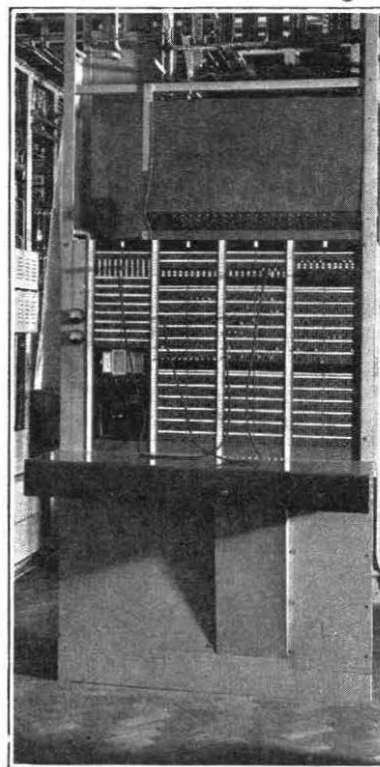

FIG. 2.—THE ENGINEERING CONTROL BOARD.

† Executive Engineer, Telegraph Branch, E.-in-C.'s Office.

¹ Wilcockson, H. E., and Mitchell, C. W. A. The Introduction of Automatic Switching to the Inland Teleprinter Network, *I.P.O.E.E.* Printed Paper No. 195.

provided. Test final selectors are not used. The physical arrangement of the E.C.B., which follows the standard Trunk Test Rack, is illustrated in Fig. 2.

The E.C.B. is used to extend circuits to the test desk and to provide patching facilities. The amount of patching required on automatic circuits is expected to be small, but since non-automatic circuits may be routed via the E.C.B. the provision of patching facilities is essential. To enable circuits to be intercepted without interfering with established connections, and to meet patching requirements, a 6-jack appearance is used, the station line and trunk circuit jacks being wired in such a way that when a circuit is split for testing, the correct busying conditions are applied automatically to the idle side of the circuit. The initial installations are equipped with loose 6-way cords terminated in 6-way plugs for patching and testing, but development of a cord canopy using 6-way cordage is in hand.

Other facilities provided include call circuits; loop, space, mark, and earth jacks for miscellaneous testing; milliammeters for line current measurements; jacks for the distribution of teleprinter test messages and speed test signals; and a motor-driven megger provided on the basis of one per suite. Circuits are provided to the adjacent phonogram installation to permit T.T. working over the teleprinter station lines on a reserve basis, and in addition use is made of the E.C.B. to gain access to circuits for observation purposes.

Speaker and Test Set (Fig. 3).

This test set provides facilities for testing the physical ends of station lines routed over M.C.V.F. channels and will normally be located at the M.C.V.F. terminal at the station

Although the Speaker and Test Set has been introduced primarily for maintenance on the Teleprinter Automatic Switching System, facilities have been included to permit the testing of other types of circuits to reduce the number of test sets required at M.C.V.F. terminals. The range of circuits for which this tester may be used includes manual Telex lines, T.M.S. lines and point-to-point circuits, and for these circuits the facilities provided are similar to those given by the existing Test and Observation sets, viz., monitoring, line current measurements, local record, teleprinting in either direction, clearing on T.M.S. lines, and connection to a synchroscope for teleprinter speed testing. A new facility is an audible alarm connected to the free side of a circuit split for testing, to enable faultsmen to attract the attention of the testing staff.

For automatic circuits, the facilities provided include, in addition to the standard facilities outlined for non-automatic circuits, dial testing in conjunction with either the Tester No. 43, or the Dial Speed/Ratio Tester (Tester TG 5186), calling and clearing (with C.C.I.T. recommended signalling), and a facility for checking the functioning of circuits designed to respond to a 20-40 mS negative pulse. This latter facility enables a check to be made of the performance of a position circuit in response to the proceed-to-dial signal, and of trunk and speaker circuits in response to the test pulse returned on seizure. Provision is made for the Electronic Stop/Start T.D.M.S.² to be switched into circuit for signal distortion and allied tests on all types of circuits.

The Speaker and Test Set is normally fitted adjacent to the S.A.B. in the M.C.V.F. terminal at the station end of the line, and the S.A.B. is used to obtain access to the lines to be tested. Pending the introduction of test desks, Speaker and Test Sets are being used for line testing at switching centres, using the E.C.B. for test access purposes.

Dial Speed and Ratio Tester.

This tester is designed for use with Speaker and Test Sets, and has been fitted initially only at switching centres. It enables control to be exercised over the impulsing performance of station equipment, especially the dial and impulsing relay, to ensure that the impulsing limits of 9-11 i.p.s. and 57-74 per cent. space (or break) ratio, measured

at the zone or Class 1 switching centre, are not exceeded.

The tester comprises a relay group (Fig. 4(a)) and a resistor-capacitor timing bridge, the relay group being arranged to respond to the dialled impulses to feed selected portions of the impulse train to the timing bridge for measurement. The use of a polarised relay to repeat the impulses into the timing bridge ensures low repetition distortion. The indicating device is a centre-zero meter and the measurements are made with respect to fixed limits, i.e. the bridge elements are set to fixed values and the meter indicates whether the interval measured is shorter or longer than that corresponding to the bridge setting.

The time intervals selected for measurement are shown in Fig. 4(b). When a single digit "0" is dialled, five separate timing measurements are taken. Each time interval is measured by allowing a capacitor to charge in series with a resistor for the duration of the time interval, and the voltage built up on the capacitor is checked by comparison

² Wheeler, L. K., and Tissington, R. S. An Electronic Distortion Measuring Set for Start/Stop Telegraph Signals, *P.O.E.E.J.*, Vol. 43, p. 18.

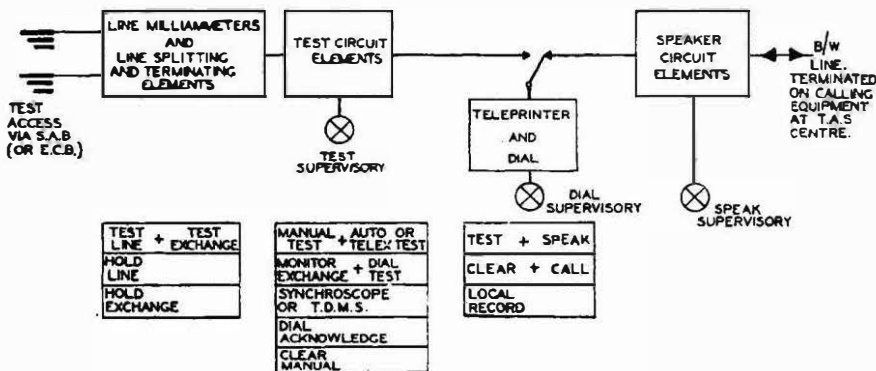

FIG. 3.—BLOCK SCHEMATIC DIAGRAM OF SPEAKER AND TEST SET.

end of the circuit. Speaker communication is by means of a both-way circuit connected to the automatic equipment at the switching centre. Ultimately, the number of Speaker and Test Sets will be such that the dialled speaker network will replace, substantially, the present point-to-point speaker network. The facilities provided for speaker circuits differ considerably from those provided for station lines. There is no automatic starting of the teleprinter motor, and, until the teleprinter motor is switched on, the speaker circuit is automatically busied. A waiting facility is provided whereby the caller receives the *MOM* signal whenever the teleprinter is not available for immediate connection to the speaker circuit (e.g., it may be engaged on testing). In the meantime, the call is indicated by the lighting of a lamp on the Speaker and Test Set, and the operation of the floor alarm in the M.C.V.F. terminal. Overflow, automatic answer back, and paper-fail facilities are not required and are not provided on speaker circuits. Provision is made for an automatic test of the speaker circuit on seizure for an incoming call, the *DER S* signal being returned to the caller if the circuit tests faulty.

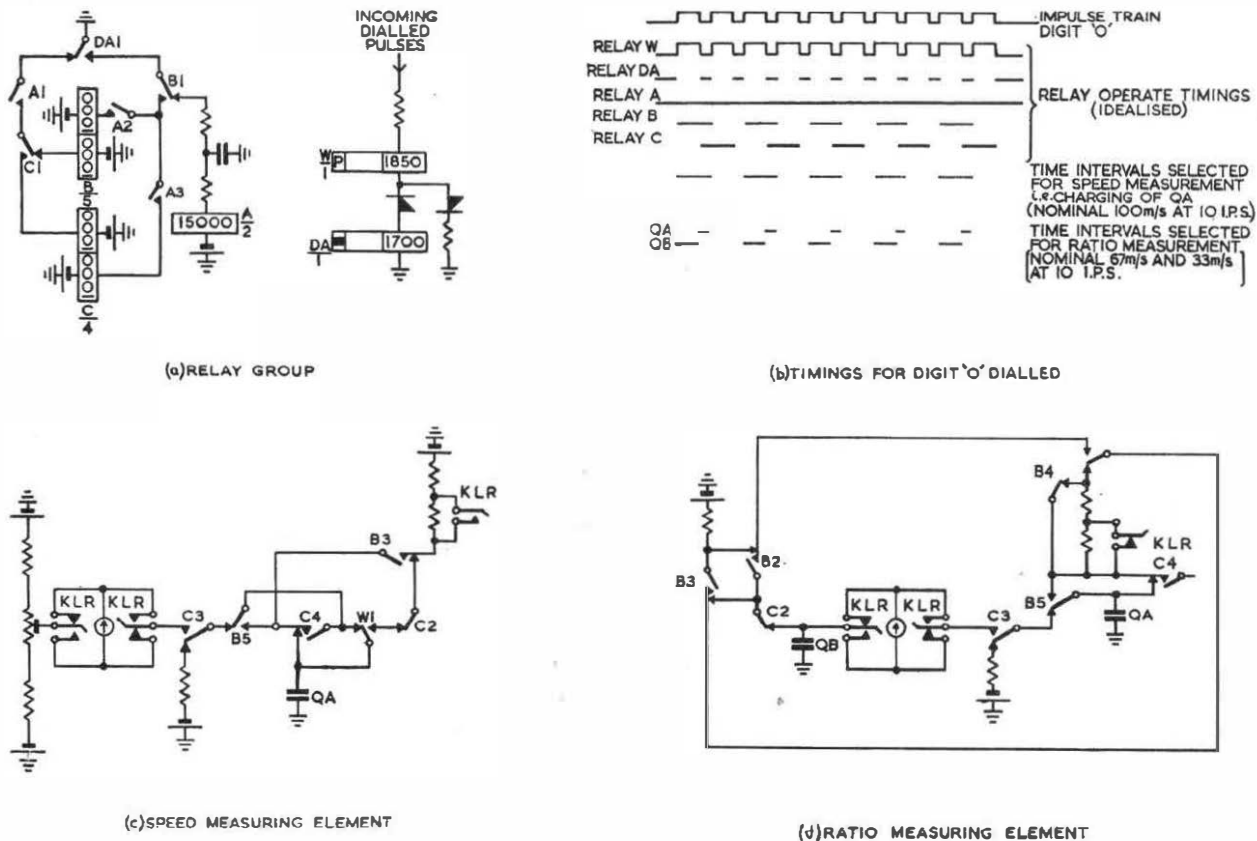

FIG. 4.—ELEMENTS OF THE DIAL SPEED AND RATIO TESTER.

with a resistive potentiometer, using the centre-zero meter as the indicator.

To check the speed of a dial, two separate measurements are necessary: to check (a) that the speed is slower than 11 i.p.s., and (b) that it is faster than 9 i.p.s.; consequently the timing bridge (Fig. 4(c)) is set to balance at time intervals of 90.9 mS and 111.1 mS respectively. The key which changes the bridge settings also reverses the meter connections permitting the meter to be marked to show that a deflection in one direction indicates "within limits" and a deflection in the other direction "out of limits."

For ratio tests (Fig. 4(d)) two resistor-capacitor combinations are used, one capacitor being charged during a break period and the other during the following make period. It may be shown that if the voltages built up on the capacitors are equal, the impulse ratio is equal to the ratio of the CR values. This relationship is independent of the impulse speed, and is the basis of ratio measurement used in the tester. The fixed-limit technique used for speed is also used for ratio measurement.

Calibration of the timing circuits is effected by using the 20 c/s signal from the Signal Generator D.C. No. 3, the speed of which is controlled by a 50 c/s valve-maintained tuning fork. The 20 c/s signal is converted by a relay group into the equivalent of a 10 i.p.s. signal of 50 : 50 ratio, which is fed into the timing bridge to enable the bridge constants to be preset to give a balance. The accuracy of this conversion to 10 i.p.s., 50 : 50 ratio is not affected appreciably by line distortion of 10 per cent. or less (measured on a 50-baud signal), and it is possible to calibrate the tester at a remote station by dialling the Teleprinter Speed Test Signal at the switching centre. The stability of calibration is independent of battery voltage since the circuit arrangement is a bridge. The most likely source of error arising from change in component characteristics is biasing of the polarised relay, and a simple neutrality check for this relay is built into the

tester. Standard ratebook resistors and capacitors are used and an accuracy of the order of 1 per cent. is achieved.

Manual Tester for Teleprinter Stations (Fig. 5).

This is a small portable tester of weight 15 lb. designed for use by engineering staff for fault finding and routine

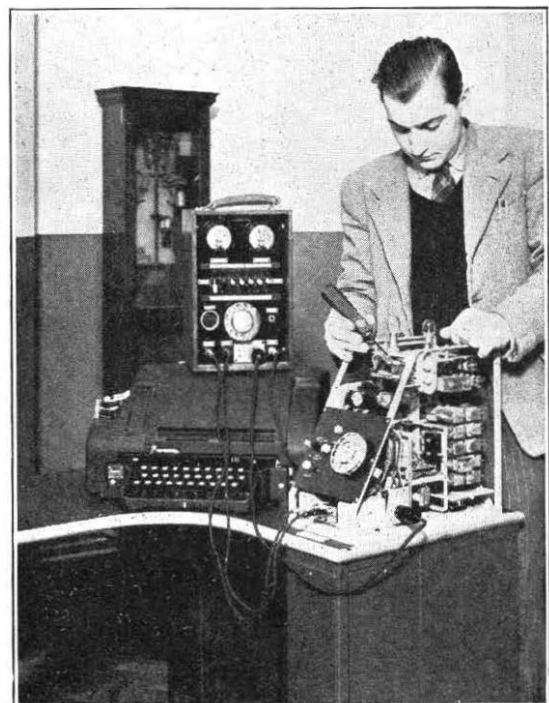

FIG. 5.—MANUAL TESTER FOR TELEPRINTER STATIONS.

maintenance at T.A.S. stations. The basis of provision is one per teleprinter office. The facilities provided include line current measurements, checks of the functioning of calling and clearing operations, and timing checks on relays. A test lamp probe is provided to enable continuity tests to be carried out on the position circuit wiring. The plugs and cords required for connecting the tester to the position equipment are carried in a small compartment at the rear of the tester, and since Control Boards are not required at T.A.S. offices, a pair of jacks is provided on the dialling unit to permit test access to the line conductors by engineering staff. The cover of the dialling unit has to be removed to expose these jacks for use.

In designing the tester use has been made of the teleprinter as a source of pulse signals to provide a means of checking relay performance. Thus, the holding of the supervisory relay (relay RA) is checked by sending into the position relay set a signal of 20 mS negative and 130 mS positive, continuously repeated, obtained by inverting the plugged Letter Shift character.

A similar test is that in which timed pulses are used to check the operate lags of the I and RA relays in the position relay set. A single Letter Shift character is inverted to produce a 20 mS negative pulse to check the maximum operate lag of relay I, and a 40 mS pulse obtained from the inversion of a single "V" character is used to check the minimum operate lag of relay RA.

A check on the maximum and minimum release lags of relay RA is provided by using an 8 i.p.s. dial in conjunction with a relay as a timing device to obtain nominal 350 and 250 mS positive pulses. The higher value corresponds to the maximum release lag, and when a positive pulse of this duration is applied to the R-wire, a clearing condition is set up in the position relay set. A positive pulse of 250 mS duration, similarly applied, corresponds to the minimum release lag and should not set up a clearing condition.

Teleprinter Speed Tester.

The importance of ensuring that the motor speeds of teleprinters connected to the system are maintained within limits is fundamental; consequently the Teleprinter Speed Tester (Tester TG 5181), illustrated in Fig. 6, has been developed.

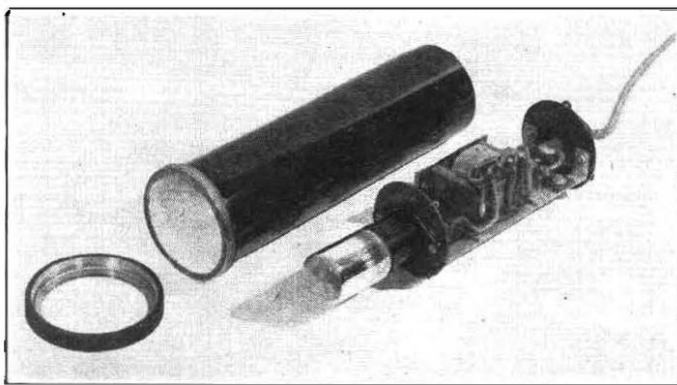

FIG. 6.—THE TELEPRINTER SPEED TESTER.

It comprises a neon lamp and an auto-transformer connected as shown in Fig. 7 (a), and fitted in a portable cylindrical container terminated in a cord which may be plugged into a jack on the dialling unit. This arrangement permits access, by dialling, to a circuit at the switching centre distributing the Teleprinter Speed Test Signal, and so allows a segmented disc on the teleprinter to be illuminated stroboscopically.

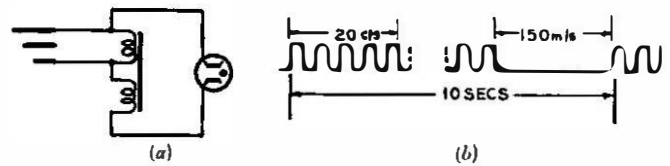

FIG. 7.— TELEPRINTER SPEED TESTER, (a) CIRCUIT, (b) TEST SIGNAL.

The Teleprinter Speed Test Signal (Fig. 7 (b)) consists of 20 c/s reversals interrupted every 10 secs for 150 mS, so that the illumination of the segmented disc is "blacked out" at 10 sec. intervals to provide a means of checking the speed of drift of the pattern. The speed limits chosen correspond to two segments drift in the pattern between successive blackouts.

The timing of the Teleprinter Speed Test Signal is of adequate accuracy since this signal is produced by the Signal Generator D.C. No. 3, which runs in synchronism with the output of the 50 c/s valve-maintained tuning fork.

Relay Set Portable Routine Tester (Fig. 8).

The quantity of switching equipment is insufficient to justify the rack mounting of routine testers, consequently testers of a portable pattern have been introduced, using Testing Stands No. 22 as the basis of the physical design. Access to the relay sets under test is by means of plug-ended cords inserted in the test jacks on the relay sets. A jack on the relay set rack feeds pulses, battery and earth supplies, etc., to the routine tester.

One tester is capable of testing either Relay Sets Outgoing from Group Selector Levels, or Bothway Trunk Relay Sets, the necessary differences in circuit conditions being established by key operation. Each relay set is subjected to 19 tests applied automatically in sequence under the control of uniselectors in the tester, and the tests include, in addition to functional tests of the relay sets, timing tests for relay lags and a test for the holding performance of the B relays.

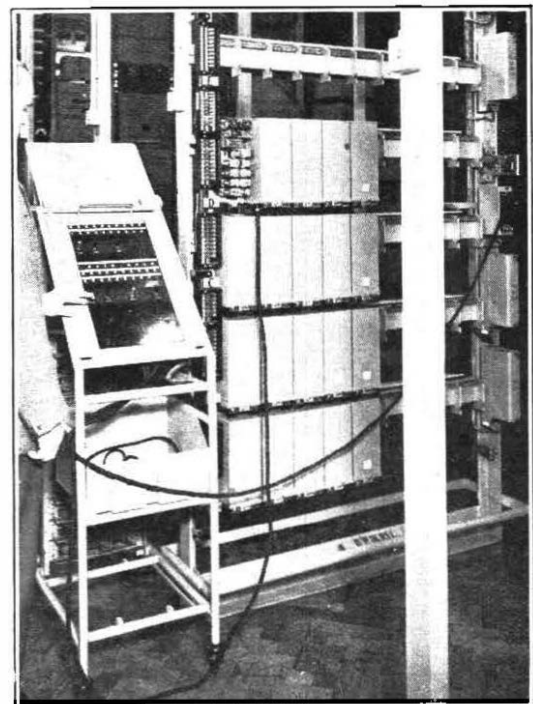

FIG. 8.— PORTABLE ROUTINE TESTER FOR RELAY SETS.

The timing circuit (Fig. 9) is a bridge combination in which a capacitor is allowed to charge in series with a resistor for the period of the time interval to be measured. The voltage built up across the capacitor is compared with that across the potentiometer arm. A polarised relay of the Carpenter type is used as the detecting device to compare the two voltages. Since the timing measurement is made with respect to a predetermined value, it is necessary to carry out two measurements on each relay lag to ascertain that the value lies between maximum and minimum limits.

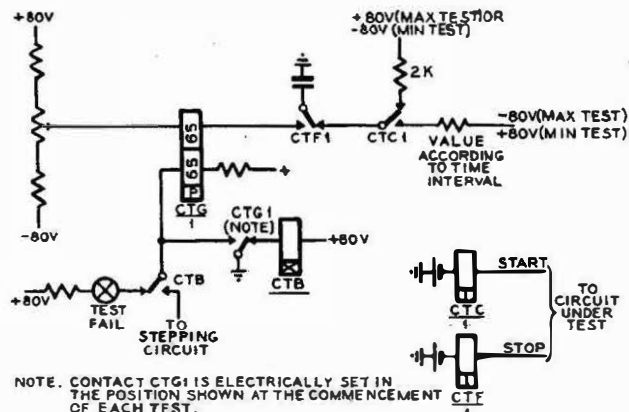

FIG. 9.—THE TIMING ELEMENT OF THE RELAY SET ROUTINE TESTER.

Adjustment of the timing circuit is effected by using a small calibrator unit which injects a pulse of 200 mS into the routine tester. The calibrator may be used to adjust timing circuits in other testers.

The holding test for the B relays is designed to ensure that holding is satisfactory during the transmission of the most onerous teleprinter signal subjected to adverse distortion, and consists of the application to the A relay of a signal of 15 mS negative and 135 mS positive, continuously repeated.

Selector Portable Routine Testers.

Separate testers are provided for the group and final selectors. In physical design and method of access to the

equipment under test, they are similar to the relay set routine tester. The test cycle for group selectors comprises 42 tests and that for final selectors 51 tests.

The tests applied include impulsing at 12 i.p.s. with ratios of 50/50 and 80/20 to prove the performance of the selector mechanism and impulse control relays. The impulses are generated by prototype models of the Impulsing Machine No. 9A, which is being introduced for telephone exchange testing.

The functional tests, relay timing and holding tests are similar to those already described for the relay set routine tester. The group selector routine tester is fitted with a key to establish the conditions required for testing first, second or trunk selectors.

Further Developments.

As previously explained, the items described in this article were those produced for the introduction of the Teleprinter Automatic Switching System. Additional items, necessary to meet requirements as the network expands, have reached advanced stages of development, and include a test desk for switching centre fault control purposes, speaker sets to enable M.C.V.F. terminals to be connected to the network; and a portable, automatic, position relay set routine tester. The last item, which has been developed to facilitate centralised maintenance on position relay sets, applies 97 tests to a position relay set plugged into the tester. A prototype of this tester has operated satisfactorily and was of considerable assistance in testing relay sets manufactured for the initial installation. A minor, but essential, item under development is a test lamp capable of testing, in addition to the 50 V and earth conditions normally found in automatic switching equipment, circuits using ± 80 V signalling supplies.

Acknowledgments.

Acknowledgments are due to those members of the Telegraph Branch who collaborated in the development of the items described, and who also assisted with the material for this article.

Book Review

"Short-Wave Wireless Communication including Ultra-Short-Waves," Fifth Edition. A. W. Ladner, A.M.I.C.E., and C. R. Stoner, B.Sc.(Eng.), M.I.E.E., M.I.R.E. Chapman & Hall, Ltd. 1950. 717 pp. 417 ill. 50s.

In the preface to the fifth edition, the authors claim to have continued their tradition of producing a textbook dealing with the general principles of short-wave wireless communication. In general, they have succeeded, and the book will be of value to students and those interested in a general survey of the techniques used in the field of radio communications.

The authors have been associated with communications work for a long time, and the book, which is well arranged for easy reference, presents a general picture of short-wave communications such as is rarely found in a single textbook. The additional chapter on Vision Intelligence and Wave-Guides indicates the increased attention given to transmission on frequencies above 30 Mc/s. Extensive lists of selected references are associated with each chapter, although few of these are mentioned directly in the text.

Chapter 5, dealing with Propagation through the Ionosphere, gives some fundamental theoretical work on the bending of an electro-magnetic wave in an ionised layer, followed by descriptive sections on the effect of collision and the effect of the earth's magnetic field. The sections dealing with Measuring

the Properties of the Ionosphere and the Structure of the Ionosphere outline the method of measuring layer height and vertical incidence critical frequencies, and are followed by 11 pages of descriptive comment on various aspects, such as fading, attenuation and scattering. In pursuing the question of choice of wave-length, the authors explain that, although recent charts are produced in a different form, Eckersley and Tremellen charts lend themselves better to a general explanation of principles. One is, therefore, disappointed to find that, when the recent charts are mentioned again, they are dismissed in a brief paragraph without a single example.

Whilst the book has been brought up to date in most important respects, students might find the arbitrary classification of radio waves in Table 1 of the Introduction somewhat confusing, in view of the metric classification proposed at Atlantic City in 1947. Some categorical statements have been left in the text which might have been made less specific: for example, on page 3, an upper limit of 25 Mc/s is given for short-waves useful for long-distance services. Again, when dealing with frequency modulation in the chapter on Modulation of an H/F Carrier, a signal/noise improvement of 30 db. relative to an amplitude-modulated transmission of the same peak power is quoted with only two provisos regarding deviation and signal/noise ratio. A more complete outline of the value of frequency-modulation would have been given if the dependence of the signal/noise ratio on deviation ratio had been shown.

A. C.

Kiosk Trailers

J. J. Moffatt, Assoc. I. Mech. E., A. M. I. E. E.,
and A. G. J. Fagg

U.D.C. 656.135:621.395.721.2

By completing the assembly and fitting of kiosks at a central point and transporting to site for immediate installation, ineffective time on site is greatly reduced. This article describes a new trailer designed to meet the transport requirements, i.e. ease of loading and unloading, and protection from damage during transit.

Introduction.

THE question of expediting the installation of new kiosks has been the subject of considerable thought in several parts of the country, and the solution now generally favoured is the assembly, painting and fitting of apparatus at central points and subsequently transporting the completed units to the required operational sites.

The manufacture of kiosks in the form of a kit of parts, although having considerable merit from the viewpoints of manufacture, distribution, storage and replacement of parts, entails a number of disadvantages. The practice in the past has been to convey the kit of parts to the operational site and there to assemble them, apply four coats of paint (each of which needs to be dry before a subsequent coat is applied) and fit the apparatus. Kiosks, however, are very frequently installed on sites at appreciable distances from the headquarters of the staff and a considerable amount of ineffective time is involved in these separate operations.

The scheme of centralised assembly offers advantages by the employment of staff, some of whom may be on light duty due to recent illnesses, in better working conditions unaffected by climatic variations, and also in the elimination of ineffective and costly travelling time. Like so many schemes evolved to eliminate current difficulties, the new ideas are not without their attendant problems, and in this case, it is essential that a simple and ready means be available for transporting the complete kiosk to the operational site without the risk of damage to the unit or its contents.

The development of light trailers for this purpose has been reported earlier in this Journal¹; the following description covers a further type which embodies a number of new features and shows promise of providing a satisfactory solution.

Design and Facilities.

Fundamentally, the trailer consists of a pair of pneumatic-tired road wheels mounted on quarter-elliptic springs and supporting a framework including a pair of rotatable inter-connected radius arms, on the extremities of which is mounted a clamp for gripping a telephone kiosk above the position of its mass centre. The inter-connected radius arms are fixed to a large-diameter pulley sheave and are moved through an arc of approximately 120° by means of a wire rope passing round the sheave from a hand-operated worm winch.

When it is desired to load a kiosk, the trailer is placed around the kiosk (Fig. 1) and the clamp secured in position. The operation of the hand winch then lifts and turns the kiosk (Fig. 2) until it is approximately horizontal and in the travelling position (Fig. 3). Unloading at the operational site is the simple reversal of this method. The placing down of a kiosk in exactly the required position is facilitated by the provision of a plumb-bob line marked on the trailer chassis.

To ensure that the radius arms are in the appropriate position for loading, the words "loading" and "position" have been painted on the moving pulley sheave and the fixed framework respectively, and are positioned so that a

white line between the words becomes continuous and straight when the radius arms are in the correct position.

The weights of the trailer and the kiosk are approximately 11 cwts. and 16 cwts., respectively, and the design must be such that when the hand winch is operated, the lighter unit does not lift towards the heavier unit. This is accomplished by the provision of a pair of jack posts on the rear extremity of the chassis (see Fig. 2), one on each side of the kiosk. It is essential that these jack posts fit snugly to the sides of the kiosk as it is necessary, on occasion, to install a kiosk in a very restricted space near walls or in a suite with other kiosks. As the rear jack posts are fully adjustable it is possible to place the kiosk upon a surface which is either higher or lower than that upon which the trailer is standing, within limits of about 9 in. up or down.

It will be noted from the illustrations that although when travelling the kiosk remains held in its clamp, a safety measure is also provided by means of a removable tie-bar between the rear of the chassis members (see Fig. 3). This tie-bar, which also carries the dummy number plate and the trailer T plate required under the Road Traffic Acts, is secured to the chassis by means of a short length of chain to prevent loss and, during the kiosk-handling operation, is swung round and stowed in a pair of brackets.

To avoid the risk of damage to the finished paintwork, all points where the kiosk touches the trailer are faced with rubber. The resilience of the rubber on the clamp, together with other factors, permits a relative movement of about 2 in. to occur between the clamp and the kiosk, when the weight of the kiosk is first being taken by the radius arms. A short length of balata strip has therefore been secured to the clamp outside the rubber, and this strip transfers the relative movement from the painted surfaces to the area between the balata strip and the rubber-faced members, thereby preventing the risk of disfigurement to the finished paintwork.

When the trailer is unladen, the kiosk-clamping arms are placed and secured in pockets in the back of the kiosk-clamping plate which is stowed across the rear of the chassis.

The sites on which the kiosks are placed are often where direct access by a motor vehicle is not possible, e.g., across pavements (Fig. 4) or grass margins, and in such circumstances, manual manoeuvring of the laden trailer becomes necessary. It is therefore an inherent feature of the design that the balance of the laden trailer about the road wheels is as nearly complete as practicable. At the same time, however, a small downward load on the draw-bar is required from the road-towing aspect. The provision of a readily retractable castor-wheel (fully retracted when on tow) gives the solution to these conflicting requirements and also provides stability to the trailer when standing in a laden or unladen condition. The pair of metal ramps seen in Fig. 4 are provided for use when it is necessary to mount curb stones or similar obstructions and are accommodated in the chassis.

Performance.

During the trial of the prototype trailer, it was noted that without undue exertion the loading of a trailer could

¹P.O.E.E.J., Vol. 42, p. 55 and Vol. 43, p. 53.



FIG. 1.—PLACING TRAILER AROUND KIOSK.



FIG. 2.—KIOSK LIFTED AND BEING TURNED.



FIG. 3.—THE LOADED TRAILER ON TOW.



FIG. 4.—MANŒUVRING TO OPERATIONAL SITE.

be accomplished in $3\frac{1}{2}$ minutes by one man assisted, for convenience in some operations, by a second man. The unloading, again including all operations, also requires $3\frac{1}{2}$ minutes. The actual time required to load the kiosk from its standing position with the clamp in position to its travelling position on the kiosk trailer requires only one minute.

The centre of gravity of the laden trailer is low and this, combined with a wheel track-width of approximately 6 ft. and quarter-elliptic springs, provides, even on bad road surfaces, the extra smooth travelling essential when carrying a thin cast-iron and glass structure.

Conclusion.

In conclusion, it is mentioned that although no finality in the design is suggested, it is considered that a pro-

gressive step has been made in providing a means of expediting this class of work and eliminating a substantial amount of ineffective time, bearing in mind that approximately 3,000 telephone kiosks are erected each year in the British Isles. The psychological effect on the public of the rapid installation of a complete kiosk and having it ready for use in a very short time should not be overlooked. The use of this type of mechanical aid has recently materially assisted the expeditious erection of over 70 kiosks in less than one week for the Festival of Britain Exhibition. Although the trailer was designed for transporting a single kiosk, it is foreseen that it may be utilised for transporting other equipment of comparable weight or shape, e.g., a boxed U.A.X. unit.

It is desired to express appreciation of the co-operation freely given in the production of these trailers by the Low Loading Trailer Company of Bedford, England.

Book Review

"Bibliography Series No. 1, Magnetic Recording, 1900-1949." The John Crerar Library. 60 pp. \$2.

This bibliography covers a half-century of development of magnetic recording from Poulsen's original wire recorder to present-day technique using coated plastic tape. A most comprehensive list of articles is quoted, including the original German references to the Magnetophone and other important writings on the subject.

Unfortunately some difficulty may be caused to users by the method of presentation. References are arranged in chronological order, but no attempt has been made to separate

theoretical articles from a very large number of works concerning applications. Some of these latter are so "popular" as to be of no value to the engineer.

One or two references have by oversight been included twice under slightly different titles. Nomenclature difficulties in the compiler's mind are responsible for about 4 per cent. of the quoted articles being included under the heading of "magnetic recording."

Notwithstanding these criticisms this bibliography, the first of a series contemplated by the John Crerar Library, is a valuable and comprehensive guide to the literature on the subject for the period 1900 to 1949.

F. A. M.

Part 2—General Description of the New Equipment

U.D.C. 621.395.62:621.394.441

The second part of this article deals mainly with the new relay sets designed to work with Signalling System A.C. No. 1. Brief mention is also made of the arrangements for interworking between old and new equipment.

GENERAL DESCRIPTION OF THE NEW EQUIPMENT

The following are the items concerned:—

- (1) A better and cheaper type of V.F. receiver.
- (2) A new "outgoing from selector level" circuit (two relay sets) incorporating a mechanical impulse regenerator.
- (3) A new "incoming to auto" relay set.
- (4) A new "outgoing from sleeve control manual board" relay set.
- (5) A mains-operated power unit to supply power to all the V.F. receivers on a rack.
- (6) Mains-operated oscillators to provide V.F. power for a complete installation.
- (7) Testing arrangements for the above items.

The New V.F. Receiver (AT 4931 and AT 5113).¹

This new type is cheaper and less than half the size of previous receivers. It takes much less power and should be very easy to maintain since there are no adjustments, except for the normal adjustment of the Carpenter-type relays. The receiver has an extremely good impulsing performance which is virtually unaffected by normal changes in battery voltage, signal-tone frequency, signal-tone level, etc. The use of an untuned voice immunity guard circuit working roughly equally at all speech frequencies gives, with the signals employed, satisfactory immunity from false signalling due to speech, whilst also guaranteeing satisfactory signalling under poor signal-to-noise conditions, such as those when signalling in the face of speech or supervisory tones.

Since the X frequency is not used for backward signals, it is unnecessary to have a receiver capable of receiving both frequencies at the outgoing end of a unidirectional circuit. A 1 V.F. receiver (AT 5113) of similar design to the 2 V.F. receiver, but equipped for receiving the Y frequency only, is therefore being introduced for this application.

The New Outgoing Auto-Auto Relay Sets (AT 4909 and AT 4910).

These relay sets are similar except that AT 4909 is for use in battery-testing exchanges, such as the projected London Trunk Auto exchange, whereas AT 4910 is for use in earth-testing exchanges (most existing exchanges are of this type).

Fig. 4 is a simple block schematic diagram showing the essential parts of the relay set and their relation to one another. It will be seen that the relay set incorporates:—

- (i) An Impulse Regenerator² which:—
 - (a) Provides time for seizure of the equipment at the incoming end of the circuit.
 - (b) Makes the impulsing performance of each 2 V.F. circuit independent of the circuits which may have preceded it.
 - (c) Increases the inter-train pause where necessary to ensure that it

is at least the preferred minimum of 800 mS.

(ii) A Stopper Valve. This is the one-way repeater through which supervisory tones are heard on unanswered calls. When the called party answers, relay CT connects the speech path straight through and disconnects the stopper valve. The valve is also used in the two-valve circuit for timing the forward clearing signal. By using an electronic timing circuit the use of a uniselector has been avoided.

The essential parts of the combined circuit are shown in Fig. 5. When the FC relay contacts are operated, VTA

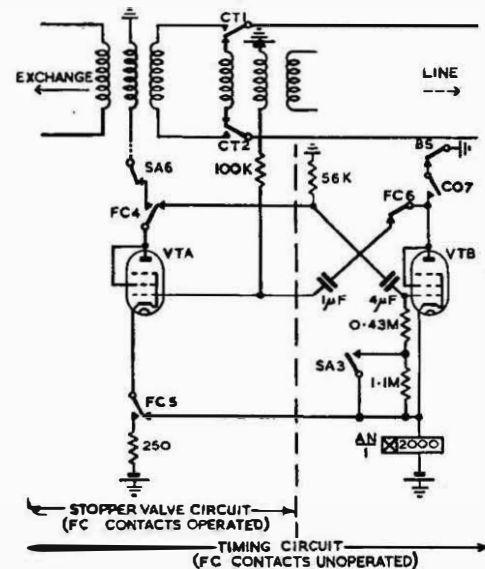

FIG. 5.—STOPPER VALVE AND TIMING CIRCUIT OF OUTGOING RELAY SET.

functions as a transformer-coupled amplifier giving a gain which makes good the loss caused by the attenuator network in the incoming relay set. When the called subscriber answers, relays CT and SA operate, taking the stopper valve out of circuit.

† Executive Engineer, Telephone Development and Maintenance Branch, E.-in-C.'s Office.

¹ See p. 118 of this issue.

² P.O.E.E.J., Vol. 30, p. 261.

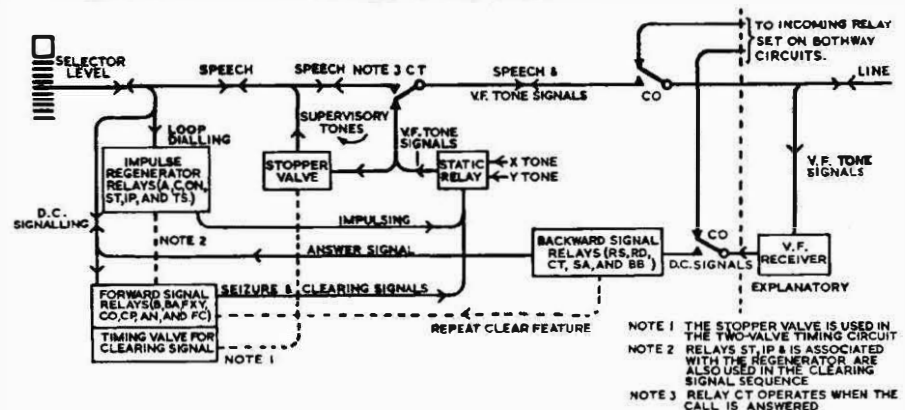

FIG. 4.—BLOCK SCHEMATIC DIAGRAM OF OUTGOING AUTO-AUTO RELAY SET.

When the calling party clears, relay B releases followed by relay FC which connects the two valves, VTA and VTB, together to form the timing circuit. The release of contact B5 causes a small current to flow via CO7 operated and VTB, but this is insufficient to operate relay AN. Release of contact FC6 connects earth to the uncharged $1\mu\text{F}$ capacitor which is unable to change its charge quickly (because of the 0.1 megohm resistor), and the potential of the control grid of VTA is driven upwards towards earth potential causing the valve to conduct (the anode current of VTA is insufficient to operate relay AN at any time). The rise in anode current causes the potential of the anode of VTA to fall and this lowering of potential is transferred by the fully charged $4\mu\text{F}$ capacitor to the control grid of VTB and biases that valve well past cut-off.

The foregoing action is virtually instantaneous and the period to be timed is now determined by the time taken for the $4\mu\text{F}$ capacitor to lose its charge via the 0.43 megohm and 1.1 megohm resistors (the 0.43 megohm resistor only, when a 2-second pulse is to be timed). When this discharge allows the potential of the control grid of VTB to rise sufficiently to allow anode current in VTB, a trigger changeover occurs since the voltage built up across relay AN raises the potential of the cathode of VTA, so reducing its anode current and causing a much larger rise in the anode potential of VTA. This change is transferred by the $4\mu\text{F}$ capacitor to increase the control grid potential of VTB and cause a substantial increase in the anode current of VTB with resultant operation of relay AN. Thus, relay AN operates at least 2 (or 6) seconds after relay FC has released.

The ultimate release of CO7 allows the $1\mu\text{F}$ capacitor to discharge via VTB ready for subsequent use.

(iii) *A Static Relay (rectifier modulator)*. The static relay controls the application of the X and Y tones to line. A double-element arrangement of static relay is used in the outgoing from selector level relay set, but it is simpler to consider first the single-element type used in the incoming relay set and sketched in Fig. 6.

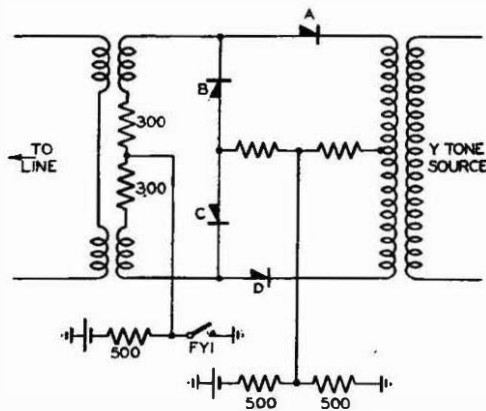

Tone to line—FY1 operated $\left\{ \begin{array}{l} \text{Rectifiers A and D conduct.} \\ \text{Rectifiers B and C biased back.} \end{array} \right.$
 No tone to line—FY1 unoperated $\left\{ \begin{array}{l} \text{Rectifiers A and D biased back.} \\ \text{Rectifiers B and C conduct.} \end{array} \right.$

FIG. 6.—STATIC RELAY, SINGLE-ELEMENT TYPE (USED IN INCOMING RELAY SET).

The action of a static relay depends on the fact that the impedance of a copper-oxide rectifier to small alternating currents varies according to the D.C. bias applied to the rectifier. In the relay the rectifiers are either biased to conduct and carry approximately 10 mA D.C., when their impedance to small alternating currents is about 80 ohms, or back-biased by approximately 10V , when their impedance rises to about $30,000$ ohms.

Thus, in Fig. 6 when rectifiers A and D are biased to

conduct by the operation of contact FY1, they represent a negligible series impedance in the connection between the transformers. Simultaneously, the rectifiers B and C will be biased back and become a shunt of high impedance which may be neglected. With contact FY1 operated, therefore, the tone source (of low impedance) will be coupled to the line, the two 300 -ohm resistors providing the usual line terminating impedance. When FY1 is unoperated, rectifiers A and D become series impedances of high value and severely attenuate the tone. Rectifiers B and C become low impedances and effectively short-circuit the attenuated tone so that there is negligible leakage to line (actually about 60 db. suppression is achieved); they also combine with two 300 -ohm resistors to provide the line terminating impedance.

The double-element type of static relay, shown in Fig. 7, works on the same principles. In the no-tone

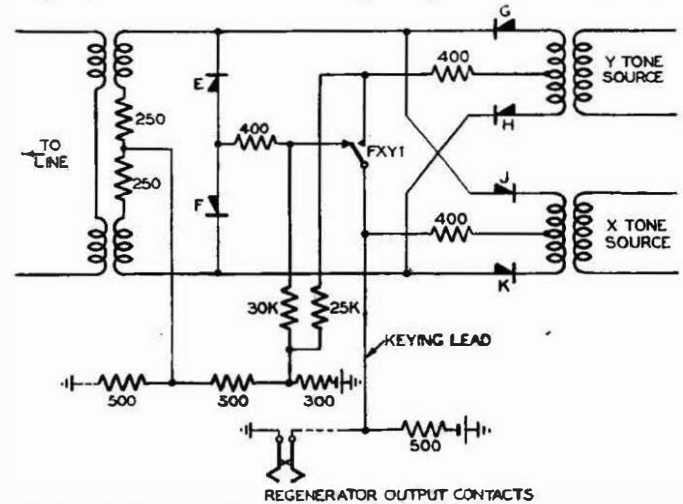

No tone to line—Earth on the keying lead and FXY1 normal; rectifiers E and F conduct, the remainder biased back.
 Y tone to line—Earth on the keying lead and FXY1 operated; rectifiers G and H conduct, the remainder biased back.
 X tone to line—Earth removed from the keying lead, position of FXY1 immaterial; rectifiers J and K conduct, the remainder biased back.

FIG. 7.—STATIC RELAY, DOUBLE-ELEMENT TYPE (USED IN THE OUTGOING FROM AUTO RELAY SET).

condition rectifiers E and F form an effective short-circuit to leakage tone and complete the line termination. Rectifiers G, H, J and K are high impedances and attenuate the tones. When either tone is to be sent, rectifiers E and F are biased by interrupting the earth connection to the 400 -ohm resistor and become a high impedance shunt which can be disregarded. Whenever the earth connection to the control lead is interrupted, X tone will be sent out (irrespective of whether FXY1 is operated or not), since rectifiers J and K will be biased to conduct and will couple the X tone and line transformers. Y tone is sent by operating FXY1, thus causing rectifiers G and H to conduct and coupling the Y tone and line transformers. When either tone is sent the other will leak at approximately 45 db. below signal level because of the absence of the low impedance shunt otherwise provided by rectifiers E and F. This leak tone is of no consequence since the signalling tone masks it.

(iv) *Forward Direction Signal Relays*. These produce the seizure signal and the forward clearing signal. The duration of the 2- (or 6-) second X tone pulse of the forward clearing signal is controlled by a two-valve circuit comprising the timing valve and the stopper valve. The inter-train pause relays associated with the impulse regenerator are used in addition to provide the timing for the Y tone pulse of the forward clearing signal.

(v) *Backward Direction Signal Relays.* These recognise the answer and backward clearing signals and transform them into D.C. signals on the calling line. They include the test-busy relay (BB) which is locked in on completion of the test-busy signal sequence (see Fig. 3 of Part 1 of this article³).

The New Incoming to Auto Relay Set (TL 3014).

A block schematic diagram of this relay set is given in Fig. 8 and anyone familiar with the earlier 2 V.F. relay sets will soon recognise this relay set as the descendant of TL 1754, TL 2754, TL 2854 and TL 2855. It converts the signals received from the line (via the V.F. receiver) into standard loop dialling conditions and sends back V.F. signals to indicate called-party answer and clear conditions.

The V.F. signals are now sent to line under the control of a static relay (rectifier modulator). Test-busy arrangements have been incorporated to provide for the signalling sequence shown in Fig. 3.

As mentioned in Part 1, the end-to-end V.F. signalling feature of the existing system has been dropped and the relay set therefore provides loop (and not earthed loop)

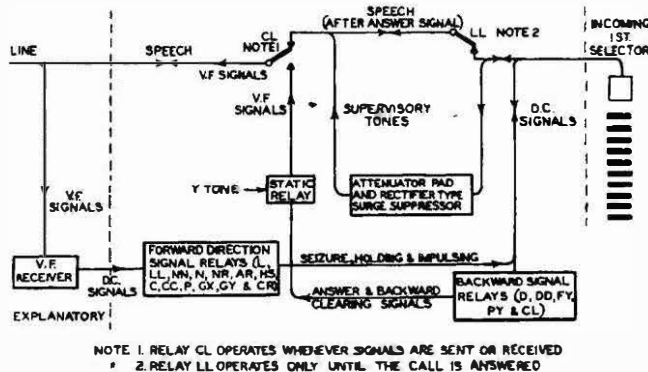

NOTE 1. RELAY CL OPERATES WHENEVER SIGNALS ARE SENT OR RECEIVED
 2. RELAY LL OPERATES ONLY UNTIL THE CALL IS ANSWERED

FIG. 8.—BLOCK SCHEMATIC DIAGRAM OF INCOMING TO AUTO RELAY SET.

seizure conditions to the subsequent D.C. switching equipment. Also as certain subsequent equipment in the local network can give rise to surges which might temporarily paralyse the V.F. receiver and prevent impulsing, surge suppression rectifiers are connected across the line until the the answer signal is received.

The New Outgoing from Sleeve Control Manual Board Relay Set (TL 3055).

This relay set bears little resemblance to the earlier relay sets (TL 1753 and TL 2753) since joint access from selector levels is no longer provided. All signals are derived from relays (and the electronic timing circuit) as in the new outgoing auto-auto relay set. This is different from the earlier relay sets which used a uniselector acting as a sequence switch and a source of signal timings.

Referring to the block schematic diagram, Fig. 9, it is seen that the relay set is generally similar to the outgoing auto-auto relay set already described, and comprises:—

- (i) *The Impulsing Relay.* No impulse regenerator is needed in this case since substantially undistorted impulses are available from the operator's dial, and seizure time is provided by the operator plugging in and throwing her dial key.
- (ii) *The Stopper Valve, Fig. 5.*
- (iii) *The Static Relay (rectifier modulator), Fig. 10.* This later design is basically similar to the arrangement

in Fig. 6, but requires less equipment as the transformer in the tone supply has been made common equipment and serves all the relay sets on a rack. Switching between the X and Y tones is by relay contacts which are "wetted" by the control currents in the static relay.

- (iv) *The Forward Direction Signal Relays* with their associated electronic timing circuit (Fig. 5) for the long X pulse of the forward clearing signal.
- (v) *The Backward Direction Signal Relays.*

A.C. Mains-operated Power Unit (TL 3018).

One unit of this type is mounted on each rack of V.F. equipment and provides the 6.3V A.C. supplies necessary for all valve filaments and the +50V D.C. necessary for the V.F. receiver valve anodes. A -50V D.C. supply is obtained from the exchange battery for operating relays, etc., and this, with the +50V from the power unit, provides the effect of a 100V H.T. supply.

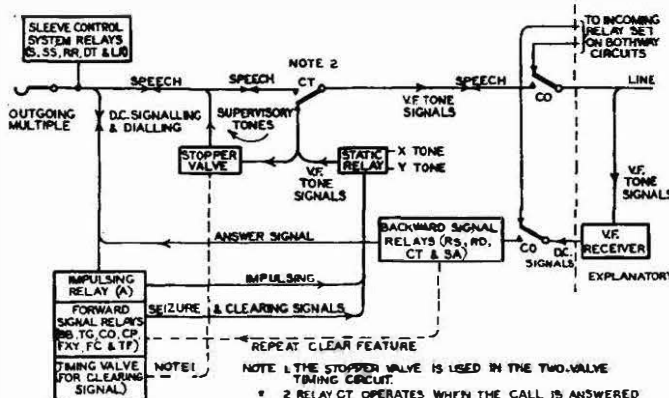

NOTE 1. THE STOPPER VALVE IS USED IN THE TWO-VALVE TIMING CIRCUIT.
 2. RELAY CT OPERATES WHEN THE CALL IS ANSWERED

FIG. 9.—BLOCK SCHEMATIC DIAGRAM OF OUTGOING FROM MANUAL BOARD RELAY SET.

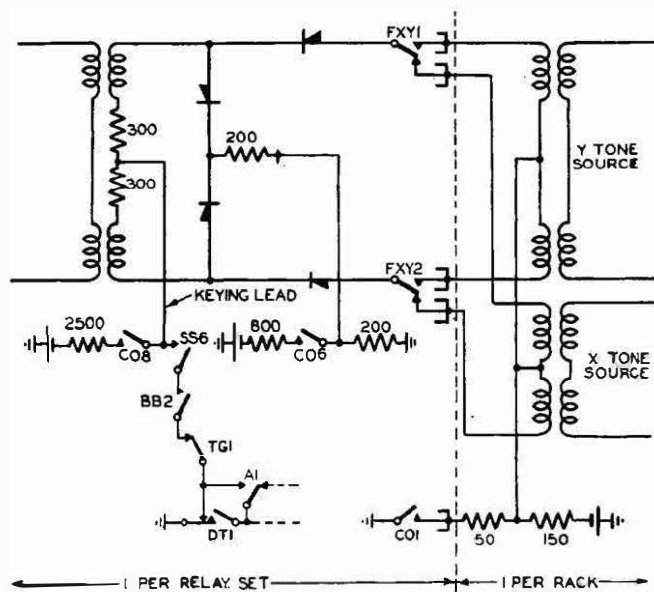

No tone to line—Earth on the keying lead.
 Y tone to line—FXY operated and earth removed from the keying lead.
 X tone to line—Earth removed from the keying lead; FXY un-operated.
 Note.—CO is operated on seizure and remains operated until the end of a call.

FIG. 10.—STATIC RELAY, COMMON TRANSFORMER TYPE (USED IN THE OUTGOING FROM MANUAL BOARD RELAY SET).

³ P.O.E.E.J., Vol. 44, p. 70.

The power unit carries the steady load due to the valves on one rack and can therefore be designed to be an efficient item. The fluctuating load, due to relays, etc., is carried by the exchange battery which is particularly suited to this type of load. Under mains failure conditions an alternative supply of A.C. at mains voltage is provided with a minimum of delay. Calls in progress are not lost, however, as the relays are supplied from the battery.

The power unit is of conventional design with bridge rectification for the +50 V D.C. supply. Selenium rectifiers are used.

V.F. Oscillators (AT 4877).⁴

Each installation comprises a power unit (AT 4812), capable of supplying up to four oscillators, and one oscillator (AT 4877) for each required frequency. Each oscillator has a power output of about 4 W. Installations of this type are also being used in lieu of machines at 4 V.F. keysending centres.

Testing Arrangements.

The principle of testing apparatus *in situ* on the racks has been adopted and routine test relays have been incorporated in the apparatus to connect it to the testing equipment. A range of equipment for thoroughly testing the new apparatus is being developed and will become available in due course. Where the amount of equipment justifies it, there is to be automatic routine testing.

INTERWORKING OF THE NEW AND OLD EQUIPMENT

In general, all variants of the system can be interworked but, owing to mounting considerations, only a limited number of types of terminal are likely to occur. These are illustrated in Fig. 11 (both-way arrangements have been omitted). The test-busy facility will only be available when new equipments are working together, i.e. (c), (e) or (f) working to (k). Where the existing incoming terminations are required to function as any but the last 2 V.F. link in a connection, a small circuit change will be needed to avoid a marginal condition which arises when the V.F. answer signal (a pulse of Y tone) arrives before the D.C. answer signal has been repeated. Without this change the Y tone pulse is converted into an impulse which might be long enough to release the connection.

CONCLUSIONS AND ACKNOWLEDGMENTS

The 2 V.F. system has been re-designed and extended to meet the requirements of trunk mechanisation. The new equipment has been made cheaper, more reliable and easier to maintain. Continued use of the same signalling principles has been thought justified because of the very short development time available and the advantages of flexibility and economies obtained when centres having old and new equipment can freely interwork.

The author wishes to thank his colleagues in the Telephone and Research Branches who have contributed so much to Signalling System A.C. No. 1. Special credit is due to those who in the 1930's originally conceived the 2 V.F. system. Their fundamental ideas have stood the hardest test of all, the test of time.

⁴ To be described in the next issue.

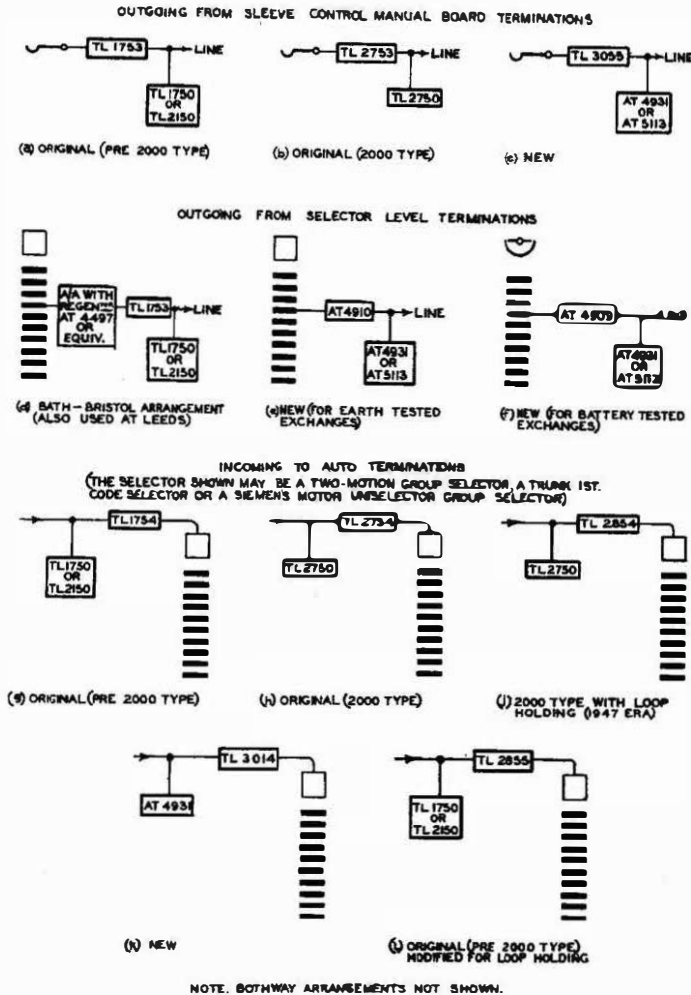

FIG. 11.—TYPES OF TERMINAL LIKELY TO OCCUR.

Book Review

"Electronic Motor and Welder Controls." George M. Chute. McGraw Hill Publishing Co., Ltd., London. 348 pp. 19s. 5s. 6d.

The text of this book consists very largely of detailed descriptions of circuits for controllers for resistance (including spot) welders and electric motors. Arc welding is not mentioned and controls for gas cutting are dealt with incidentally under motor controls.

Since the chief interest to-day is in the reduction of deviation with increased stability, those concerned with design will be disappointed to read, on page 290, "Electrical Engineers now have ways to calculate in advance whether or not a system will hunt. Such methods in detail are beyond the scope of this book."

Presumably the reason for including controls for welding and motors in one volume is that they are respectively examples of open-cycle and closed-cycle systems, but this is

not likely to be apparent to students. The treatment is almost non-mathematical and although the book is completely American, it is very easy to read. The presentation is extremely good and the diagrams, once the reader accustoms himself to the symbols, are easily followed. In choosing his illustrations, the author has not, as is so often the case, limited himself to his own firm's products, but has included a range from various American manufacturers. The reproductions from photographs are not first class and, even if the pictures were clearer, the inclusion of so many electronic controllers with or without their covers, is of very doubtful utility. One reader, at least, was thoroughly distracted by the large number of footnotes, in one of which the decibel is defined as $20 \log_{10}$ gain, but the author does not explain that this is a voltage and not a power gain. The dust cover claims that this book offers the practical assistance needed by the man who must select, install or service Electronic Controls. The installer and service-man should find it very useful.

A. E. P.

Electronic Equipment for Signalling System A.C. No. 1

J. R. TILLMAN, Ph.D., A.R.C.S.†

Part I—The New 2 V.F. Signalling Receiver (AT 4931)

U.D.C. 621.395.62: 621.394.441

Part 1 of this article describes a new V.F. signalling receiver of compact design, low power consumption and high performance. The new receiver, which supersedes the pre-war model, should require only simple maintenance routine at infrequent intervals. In Part 2 will be described a new valve oscillator (Oscillator No. 26) to replace the existing synchronous machine supplying V.F. signalling tones.

Introduction.

WHEN the decision was made to extend the 2 V.F. signalling system, the advisability of continuing to use the existing signalling receivers¹ was questioned. The receivers are large and consume much power (25 W each) from the exchange battery. They use valves which have long been obsolete and for which no modern counterparts exist—bearing in mind their unorthodox operation in the receiver. Maintenance of the receiver has presented some difficulties.

Experience with the design of signalling receivers to be used in international dialling trials had shown that modern receivers can be much smaller, consume less power and should require little maintenance. Accordingly, a specification was drawn up for a new signalling receiver to supersede those designated TL1750 and TL2750.

Performance Requirements.

The receiver must have a low power consumption; its valve heaters can be energised from an A.C. supply. It must accept variations of the voltage of the exchange battery with little change of performance; if any additional power supply is necessary, wide variations (e.g. ± 20 per cent.) in its voltage must also have negligible influence. All components must be in good and assured supply.

The receiver must accept, for signalling purposes, signals of either 600 c/s (Y) or 750 c/s (X) received (each with a tolerance of $\pm 17\frac{1}{2}$ c/s) at levels between +10 db. and -20 db. (All levels quoted are relative to 1 mW into 600 ohms.) Its impulsing performance for X signals received at levels between +10 db. and -12 db. (or preferably lower), at impulsing speeds between 7 and 12 i.p.s., must be very good; distortion should be less than ± 3 mS with any combination of permissible valve, signal level, signal frequency, battery voltages, relay adjustment and line noise (a more stringent requirement than that applying to the current receiver). The transmission loss introduced by bridging the receiver across a 600-ohm circuit must not exceed 0.3 db. at frequencies between 300 c/s and 500 c/s, and 0.25 db. from 500 to 3,400 c/s. The receiver must be adequately guarded against operation by speech currents.

DESIGN

General.

The design of a 2 V.F. signalling receiver for the international dialling trials had already shown the validity of some novel ideas for obtaining good all-round performance. Suitably adapted they were used again.

† Principal Scientific Officer, Research Station.

¹ T. H. Flowers and B. M. Hadfield. "Voice Frequency Signalling on Trunk Circuits." *J.P.O.E.E.* Printed Paper No. 162.

Research Report 9689: "Diode Stabilised Receiver for 2-Frequency Signalling and Dialling on Trunk Circuits."

² In fact they differ, but not so as to invalidate the theory qualitatively.

³ T. H. Flowers and J. R. Tillman. Brit. Prov. Pat. Appln. No. 1298/48.

The conversion of the received pulse of tone to a pulse of direct voltage is made by opposing the rectified outputs of a signal and an aperiodic (i.e. untuned) guard circuit; the time-constants of the build-up and decay of the two outputs and the ratio α between the rectified voltage from the guard circuit and that from the signal can then be so chosen that the conversion, suitably measured, is distortionless over a wide range of received level. α must be independent of the received level, an easy condition to satisfy in practice, and for a substantially aperiodic guard circuit must have a value between 0.5 and 1. Qualitatively, assuming the time-constants of build-up and decay of the rectified signal voltage to be each² t_0 , the time-constant of the build-up of the guard voltage should be less, and that of the decay of the guard voltage more, than t_0 .

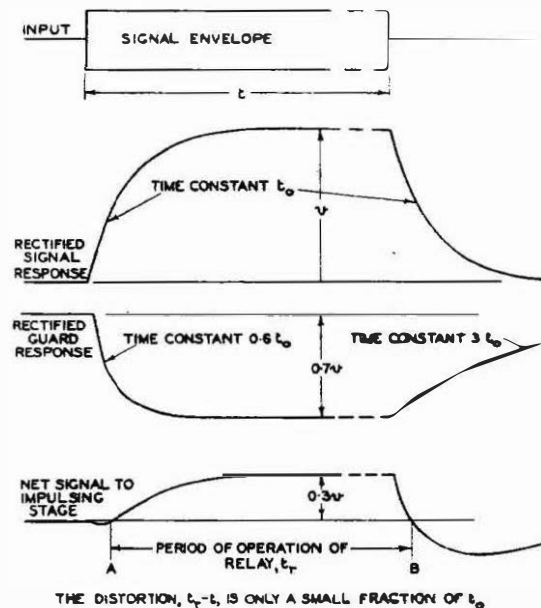

FIG. 1.—RELATIONSHIP BETWEEN INPUT SIGNAL, RECTIFIED SIGNAL AND GUARD RESPONSES, AND NET SIGNAL TO IMPULSING STAGE.

Fig. 1 shows how distortionless conversion can be obtained; here $\alpha = 0.7$, the value chosen for the receiver, and the direct voltage pulse is measured between points A and B. There is in practice a permanent guard voltage (not shown) which is present in the absence of signal or speech currents, but is superseded by any rectified guard voltage which exceeds it. The direct voltage pulse is, however, generated in a high impedance network and could not directly operate a relay. Substantially distortionless operation via an impulsing stage can be obtained provided the direct pulse generated from the lowest level of received V.F. signal is many times that needed to switch the stage, a condition easily fulfilled in many impulsing circuits. The stage designed has two important new features.³ Firstly, the

its heater consumption is less by 0.6 W, it needs no top-cap connector and it takes up less space, its use has been deferred at least until the supply of a thoroughly reliable holder is assured.

Component Layout.

The receiver mounts on a 14-way, 2,000-type relay plate (see Fig. 3). Most of the small components are housed in the pots containing the transformers: all terminals of these components are directly connected to tags on the transformer tag plates, so that individual components can be

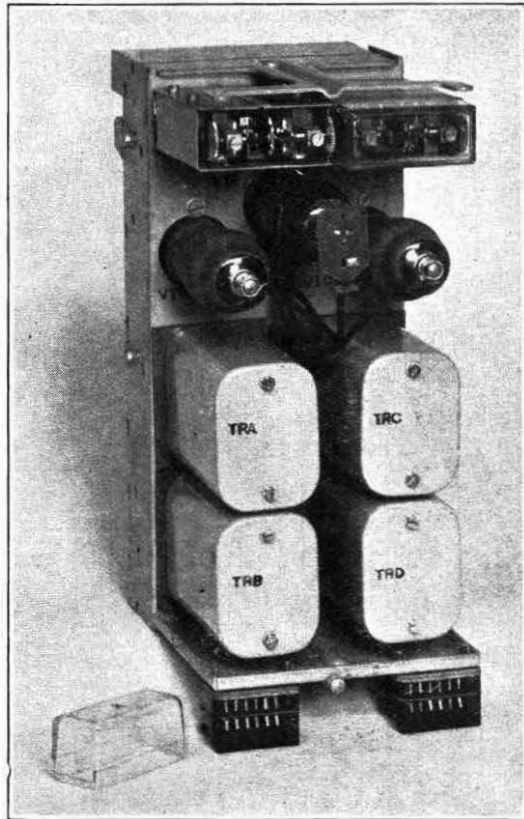

FIG. 3.—THE SIGNALLING RECEIVER AT 4931.

separately tested. The wiring is simple. All transformer, relay and valve tags, the relay contacts and the relay adjusting screws are easily accessible.

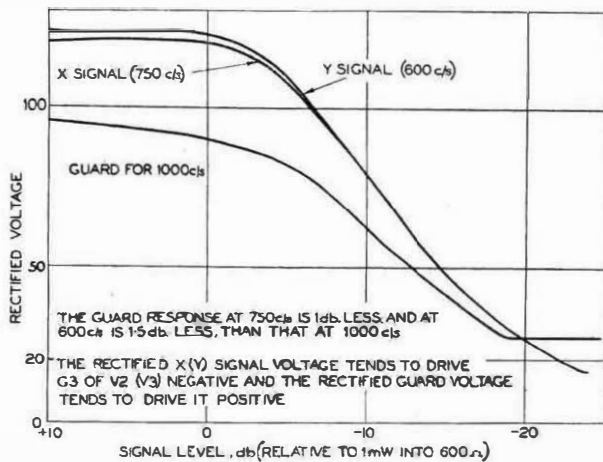

FIG. 4.—STEADY STATE RESPONSES OF SIGNAL AND GUARD CIRCUITS.

PERFORMANCE

Properties not Directly Measurable at the Output Terminals.

The responses of the signal and guard circuits are noteworthy in assisting the explanation of the operation of the receiver. Fig. 4 shows the steady state responses over a wide range of level of input signal. They were measured across the load resistors of the signal circuits and the reservoir capacitor C1 of the guard circuit, with V2 and V3 absent. A "permanent guard" of about 27 V, derived from the junction of R2 and R3 is clearly seen.

The effective ratio, x , of guard/signal rectified voltages, for signals received in the range of level from -15 db. to +10 db., is about 0.7. Fig. 5 shows the net voltage applied

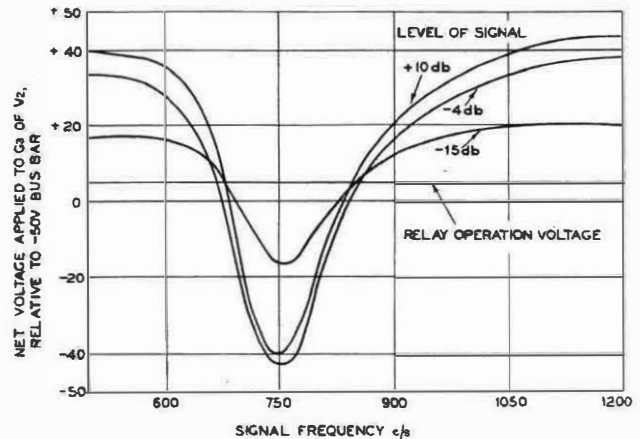

FIG. 5.—NET RECTIFIED VOLTAGE FOR THREE LEVELS OF RECEIVED SIGNAL.

to G3 of V2 with both V2 and V3 present, for three levels of input signal, as the frequency of the X signal is changed; similar curves, centred around 600 c/s, apply to the voltage impressed on G3 of V3. The ratio of the switching voltage to the grid (G3) base of V2 (or V3) is large at, and about, the signalling frequency.

The transient responses of the circuits are as expected; when signal and guard are in opposition, i.e. as they are applied to the impulsing valves, the net responses are as waveforms (b) of Fig. 6.

Effects of Bridging the Receiver Across the Transmission Path.

The input impedance of the receiver introduces the bridging loss shown in Fig. 7. In addition, at high levels of received signal, the bridging introduces amplitude distortion due to the drawing of grid current by V1 during alternate half cycles of the signal; the total harmonic production never exceeds 0.3 per cent. however.

Impulsing in the Absence of Noise.

Fig. 8 shows the impulse distortion produced when trains of, or single, X (750 c/s) impulses (of conventional durations) are received at impulsing speeds between 7 and 12 i.p.s., at levels from -22 db. upwards. Pulses shorter than 20 mS are subject to more distortion.

The distortion varies only ± 0.5 mS over the important range of input level from -12 db. to +10 db., but there is a permanent distortion of 1.0 ± 0.5 mS, a figure chosen to proportion the loss due to transit time of the relay armature equally between the times spent on each fixed contact during impulsing. Curves of impulsing distortion for

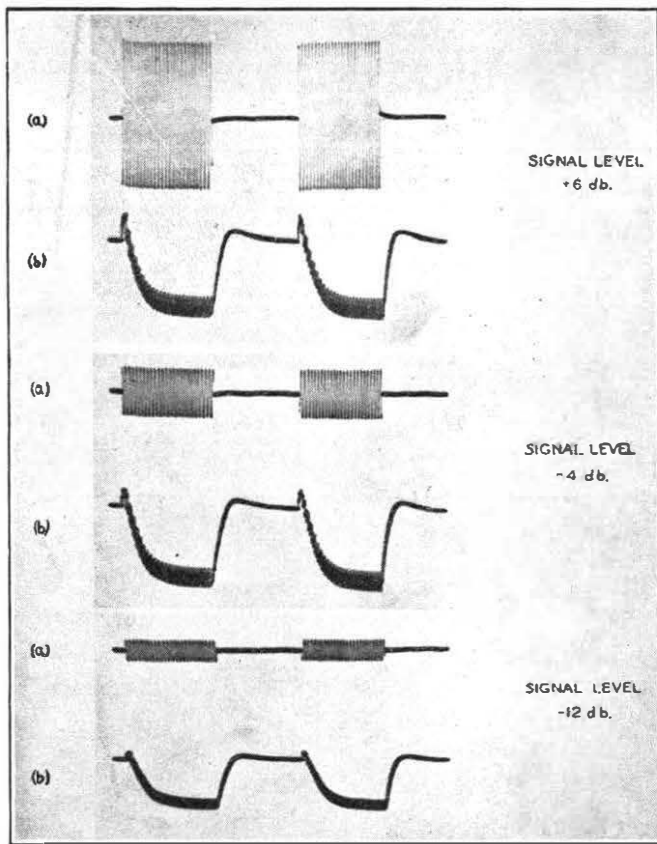

WAVEFORMS AT 15 l.p.s. OF (a) SIGNAL, (b) NET RECTIFIED VOLTAGE.

FIG. 6.—NET VOLTAGES APPLIED TO THE X IMPULSING STAGE.

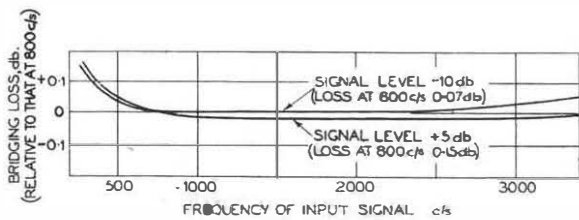

FIG. 7.—BRIDGING LOSSES INTRODUCED BY THE RECEIVER.

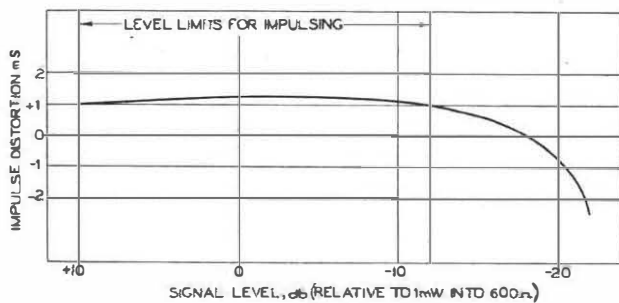

FIG. 8.—IMPULSE DISTORTION—MEASURED AS THE PERIOD THE ARMATURE LEAVES ITS BACK FIXED CONTACT LESS THE DURATION OF THE RECEIVED IMPULSE OF X SIGNAL.

signalling frequencies of 750 ± 17.5 c/s do not differ from that shown by more than 0.2 mS. Fig. 9 shows how greater errors of frequency affect the impulsing performance.

The consistency of the performance of different samples of the valve CV1347 kept the changes of impulsing performance with valve changes to less than ± 0.5 mS. Ageing of V1 to its rejection point causes less than 0.1 mS additional distortion and of V2 less than 0.3 mS. A change of



FIG. 9.—BANDWIDTHS OF THE RECEIVER.

± 6 per cent. on the voltage of the -50 V battery causes about ± 0.1 mS, and ± 20 per cent. on the voltage of the $+50$ V battery up to 0.2 mS. Even the complete failure of the $+50$ V supply, providing an electrical contact is maintained, never introduces more than 3 mS additional distortion.

The variations of impulsing performance, from new receiver to new receiver, increase from ± 0.5 mS in the range of level -15 db. to $+10$ db., to ± 1 mS at -20 db.

The contact between the armature of the X relay and its back stop breaks 10 mS after the reception of an X pulse begins: about half of this delay is accountable for in the impulsing stage itself.

The impulsing performance for Y signals, on which the requirements make no demand, is only a little inferior to that for X signals.

Impulsing in the Presence of Noise.

Fig. 10 shows the effects of continuous noise on impulsing to X signals; results for Y with a "noise" at 600 c/s in place of that at 750 c/s are similar. All expected line noises (including supervisory tones, e.g. dial tone) and signal leaks can be tolerated with large safety margins.

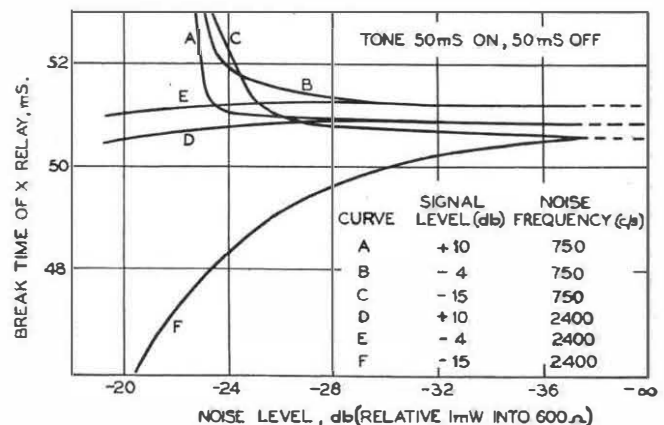

FIG. 10.—EFFECT OF NOISE ON IMPULSING.

The ability of a receiver to recover rapidly from effects produced by high-level line noises (e.g. surges produced in a link using D.C. signalling being transmitted on to the subsequent link using V.F. signalling) is gaining importance in new V.F. systems. As Fig. 11 shows, the present receiver recovers rapidly from paralysis by high levels of noise.

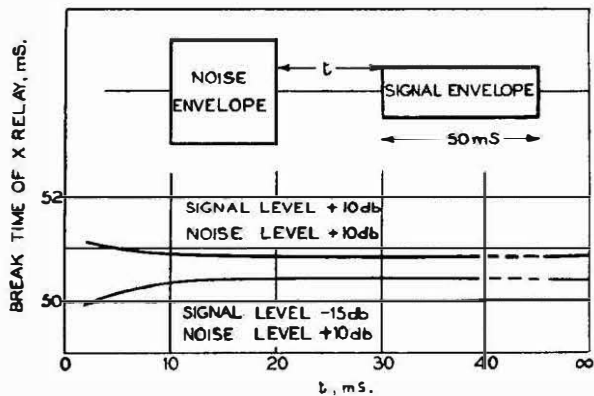

FIG. 11.—EFFECT OF NOISE PRECEDING A SIGNAL.

Overall Impulsing Performance and Sensitivity.

Some assessment of the maximum overall distortion can be made by adding individual distortions of like polarity (thus frequency errors and reduced heater voltages both reduce the time spent by the moving contact off the back fixed contact). Although measurements have shown that some combinations of adverse conditions give slightly more distortion than that so assessed, they have also shown that any receiver, using valves in any "non-rejectable" condition, receiving signals of any expected level, frequency, impulse ratio and impulse speed, and working from supplies of any expected voltages and in the presence of line noise, more intense by up to 20 db. than that normally expected, will not distort signals by more than 2 mS additional to the permanent distortion of 1.0 ± 0.5 mS. Only rarely will the 2 mS be in the same sense as the permanent distortion.

The receiver is sensitive to all true signals of level above -23 db.

The Effectiveness of the Guard Circuit.

It is convenient to show the characteristics of the guard circuit in terms of "guarding factors" (see Fig. 12). The factor for one signalling frequency is measured by applying a composite signal made up of a component at that signalling frequency and a component at a non-signalling frequency; it is the difference in level of these two components when the relay ampere-turns are zero.

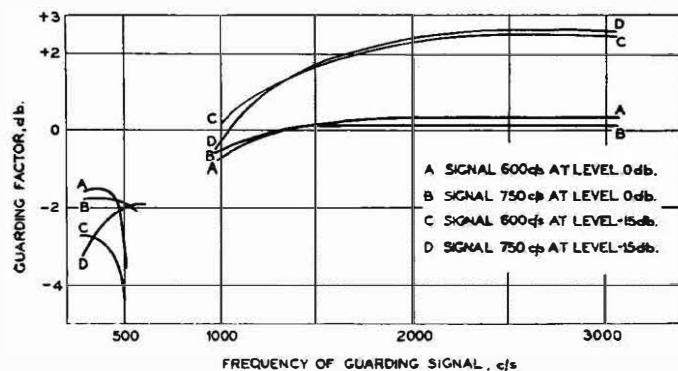

FIG. 12.—GUARDING FACTORS.

No formula exists for determining the effectiveness of a guard circuit from its electrical performance. The information which exists for substantially aperiodic guard circuits suggests that adequate immunity will be obtained with the guarding factors provided, but gives no idea of the frequency with which a Y imitation of 50 mS (or more) can be expected to follow, within 20-900 mS, a similar Y imitation, thereby simulating the "backward clear."

Tests were accordingly made of the speech immunity of the receiver when working on trunk lines having an insertion loss of, nominally, 3 db. Table 1 shows the results obtained (which are not inconsistent with the data given by Flowers and Weir⁴) and some for the signalling receiver TL 2750.

TABLE 1
Speech Immunity

Receiver	Signal imitated	No. of imitations per speech hour exceeding in duration			
		10 mS	50 mS	100 mS	50 mS-gap-50 mS
TL 2750 (best)	600 c/s	10	4	1	0
TL 2750 (worst)	600 c/s	80	33	12	2
New (AT4931)	600 c/s	160	22	4	1.8
TL 2750 (best)	750 c/s	70	16	3.5	—
TL 2750 (worst)	750 c/s	>200	90	18	—
New (AT4931)	750 c/s	90	12	2	—

Contact Pressures and Transit Times of the Relays.

The impulsing stages provide a minimum of 18 ampere-turns in the "back" direction in the absence of a true signal or in the presence of an unwanted signal of frequency 100 c/s or more outside the bandwidths, even when the valves are aged to their rejection points. The nominal ampere-turns are 22. On the reception of a true signal, the armature moves to the forward position; the minimum ampere-turns (now acting in the opposite direction) are 17 and the nominal 19.

The total contact gap chosen originally was 0.002 in. With it, 15 ampere-turns should always provide a contact pressure of 30 grams. This pressure is adequate; the small biases which the relay might assume over long periods are unlikely to reduce the practical pressures below it. The total contact gap may, in practice, be made greater than 0.002 in.; if so the contact pressures will be higher.⁵

The total transit time is nearly 2 mS for all signals.

Power Consumption.

The receiver needs a 6.3 V A.C. supply for the valve heaters, consuming in all 0.8 A. In addition, it draws 10 mA from the -50 V battery and at most 3 mA from the +50 V supply (1.5 mA during the reception of a signal). Thus, in all, nearly 6 W are consumed.

Field Trial.

In a field trial at two zone centres, lasting a year, models made by the Research Branch and others from early production by a contractor showed excellent stability. The variation of impulsing performance with time was not more than 0.5 mS, much less than the resolving power of the testing equipment as ordinarily used. The receivers were given routine tests periodically, but required no attention except to the relay contacts which showed some pitting and growth, due to inadequate quenching circuits and the use of unsuitable contact material—two weaknesses now remedied—and the replacement of two mechanically faulty valves.

MAINTENANCE FACILITIES

The valves and relays require regular inspection. The receiver allows simple, in situ, testing of each valve. When the cathode potential of a valve falls below that of a particular point in the potential divider across the -50 V

⁴ T. H. Flowers and D. A. Weir. "The Influence of Signal Imitation on the Reception of Voice-Frequency Signals," *Proc. I.E.E.*, Vol. 96, Part III, p. 223 (1949).

⁵ H. A. Turner and B. Scott. "A Polarised Relay of Improved Performance," *P.O.E.E.J.*, Vol. 43, p. 85.

supply (the junction of R4 and R5 for V1, and of R3 and R4 for V2 and V3) the valve has reached the end of its useful life. If the heater voltage of a new valve is reduced from its nominal value of 6.3 V, it is not until 3.5 V or lower is reached that the end of useful life is simulated; an average life of several years seems assured in practice. Post Office Research Report 13064 includes a description of a simple portable tester designed to do this, in situ, test; the more comprehensive tester which will be used in exchanges will incorporate the essence of the portable unit, together with a relay tester and impulse distortion measuring equipment.

Test tones, simple and complex (i.e. containing a component at a specified non-signalling frequency) can be conveniently applied to check the satisfactory working of the signal and guard circuits, but the details of how best to do the check have yet to be finally settled.

The design has deliberately avoided electrical controls, thereby easing exchange maintenance; no increase in complexity has resulted, but some resistors have had to have fine, but still commercial, tolerances.

DISCUSSION AND CONCLUSIONS

The impulsing performance of the new receiver is better than that of the receiver TL 2750, particularly when the expected variations of received frequency, of power supply voltages and of impulsing speeds, ageing of the valves and the likely out-of-adjustments of the impulsing relays are taken into account. Line noises have much less detrimental effect and noise preceding a signal cannot cause shortening of the relay response by more than 2 mS, no matter how short the gap between noise and signal (the receiver TL 2750 can easily be paralysed for 100 mS).

The initial performance is not necessarily the best that design can achieve to-day. It is unlikely, however, that systems designers could make much use of better impulsing performance or of a noise immunity greater than that provided. The only performance requirement they are likely to tighten is that of speech immunity.

The small-scale early production and the field trial have given prominence to features of the design which are likely to prove as valuable as the adequate initial performance. Thus, manufacture presents no difficulties, the operation of the receiver depends only on the conventional, specified

properties of its components and the performance is retained for long periods with no more than infrequent, simple routine maintenance.

Signalling System A.C. No. 1 uses only the Y frequency for backward signalling; consequently the receiver at the outgoing end of a unidirectional trunk circuit need not cater for the reception of the X frequency. A separate version of the receiver (AT 5113) is accordingly being produced without T3, V2, X/1, etc.

The Y signalling performance is better than the system demands, but advantage cannot simply be taken of that fact to reduce the initial cost of the receiver—no cheap polarised relay of sufficient sensitivity is marketed. The Y impulsing stage can, however, be modified to drive a Siemens high-speed relay, but the improved stability of the stage is lost.

The receiver is not intended for compound working. If it is ever required to be, some modifications, mainly to resistor values and to the X signal circuit, will be needed before certain, correct reception of compound signals, in which the levels of the two components may differ by up to 3 db., can be assured.

In conclusion, it can be said that the validity of the ideas underlying the design has been demonstrated. In addition, consistency amongst samples and constancy of performance with valve ageing have been ensured, as the field trial showed, by the combination of a little feedback in the amplifying stage, the "constant current" property of the generator feeding the signal and guard circuits, the stabilisation of the total current supplied by each impulsing stage and the use of Carpenter relays. The receiver should have a capital cost less than that of the receiver it supersedes and it is confidently expected that the less frequent maintenance required, the much reduced power consumption (1 W from the exchange battery and 5 W from a mains transformer, instead of 25 W from the battery) and the smaller rack space required, will much reduce running costs. All components are in good supply.

ACKNOWLEDGMENT

An acknowledgment is due to Mr. D. J. Whitehead who much accelerated the work by his assistance in making and testing prototype models.

Book Reviews

"Electrical Communication." 3rd Edition. A. I. Albert, M.S., (E.E.) John Wiley & Sons, Inc., New York. Chapman & Hall, Ltd., London. 593 pp. 429 ill. 52s.

Telecommunications cover such a wide field that a valuable possession for communication engineers and students is a single volume giving concise information on all phases of electrical communication, together with extensive references to the specialised literature covering each phase. Such a book is also of great value to those in the industry employed on administrative duties who wish to obtain a better understanding of the main features of communication engineering. It was these considerations which prompted the publication of Mr. Albert's "Electrical Communication" in 1934.

In the third edition extensive revisions have been made to bring the material up to date (1950) and the chapters have been regrouped to cover first the basic subjects, such as acoustics, electro-acoustics, networks, lines, cables, wave-guides, electronics; and then, complete telegraph, telephone and radio systems. Except in the chapters on Electric Networks and Transmission Lines the use of higher mathematics is sufficiently limited to enable the text to be followed with comparative ease.

For readers wishing to study a particular subject in detail,

extensive references are quoted for each chapter, although almost without exception the references are to American publications. Each chapter is further supplemented by a series of Review Questions to test one's understanding of the subject matter covered; and, finally, by typical problems (without answers).

To summarise: apart from the obvious disadvantage of the limitation on references, this is a very useful book at a not unreasonable price and can be recommended to all having an interest in telecommunications.

G. E. S.

"Radio Valve Data." *Wireless World*. 80 pp. 3s. 6d.

The new edition of this well-known reference book contains the main characteristics of over 2,000 types of British and American radio valves, and over 100 cathode-ray tubes. Eighteen British valve manufacturers alone are represented, all of whom have co-operated with *Wireless World* in ensuring that the tabulated information given is accurate, comprehensive and up to date.

The main tables give the electrical characteristics of each valve, and separate tables show their base connections. Subdivisions of the main tables further classify the valves into obsolete, replacement or current types, as recommended by the makers. An index enables any valve to be found in the tables quickly and without trouble.

Quartz Crystal Vibrators as Circuit Elements

H. E. PEARSON, B.Sc.(Eng.), A.M.I.Mech.E. †

U.D.C. 621.396.611.21

Some typical values are given for the equivalent circuit and other principal parameters of quartz crystal vibrators in the range 1-40,000 kc/s as made by the Engineering Department of the Post Office.

ALTHOUGH piezo-electricity was discovered by the Curies in 1880, and a theory in explanation of the phenomenon was established by Voigt before the end of the last century, the applications of quartz crystals in telecommunications have all been developed this century, most of them, in fact, during the last 25 years. These applications have been many in number and diverse in character, and it is not proposed to enumerate them here. Excellent descriptions of those applications which are of direct interest to the Post Office have appeared elsewhere from time to time, some of which are listed in the bibliography. The purpose of this article is primarily to record the principal characteristics of quartz crystals as made in the Radio Laboratories of the Post Office up to the end of 1950. Brief mention will first be made, however, of some of the factors to be considered in the manufacture of quartz vibrators.

Frequency Range.

Undoubtedly the first property of interest is the frequency of a crystal vibrator. Low-frequency vibrators have a large dimension, high-frequency vibrators have a small dimension, and the lower and upper limits of frequency obtainable are to a large extent determined by the size of raw material available on the one hand, and the thinnest practicable wafer on the other. These limits can be extended by the use of curved or compound vibrators at low frequencies and by overtone operation at high frequencies. Thus, a long low-frequency crystal vibrator, if made as a curved bar subtending an angle of about 350° , has a frequency only about one-tenth that of the longest straight bar which could be cut from the same piece of raw material; or, by cementing together separate pieces of crystal, a compound vibrator of any length can be made. Overtone operation is the direct excitation in the crystal of an overtone of the fundamental frequency to obtain a higher vibration frequency from the same piece of material.

By these various means, and by employing different modes of motion, quartz crystal vibrators have been supplied in the frequency range 1 kc/s to 40,000 kc/s. For any frequency in this range a crystal vibrator of some sort can be made. The same specification in respect of tolerances on frequency adjustment, stability and temperature coefficient cannot, however, be met at all frequencies in this range. Furthermore, it does not follow that the equivalent circuit of a crystal of one frequency will allow of its application in the same manner as is commonly practised at another frequency. As an example of this, crystal filter design may be very different at 10 kc/s or 1,000 kc/s from that which has long been established for 100 kc/s. Some of the limitations are a result of the development of techniques having proceeded at different rates in different frequency bands, but some are due to intrinsic properties of the quartz when used in all known ways.

Modes of Vibration.

Mention was made in the last paragraph of modes of motion. An elastic body can be caused to vibrate in torsional, shear, flexural, or in longitudinal modes. Sup-

posing the body has dimensions x , y , and z in the directions of a chosen set of orthogonal axes X , Y , and Z , then any of the modes may be associated with any of the directions, e.g. twisting about the X , Y or Z axis; shear or flexure in the XY , YZ or ZX planes; extension in X , Y or Z directions. In each case, the magnitude of one (sometimes two) of the dimensions x , y , and z plays the predominant part in determining the vibration frequency. With at least one remaining dimension variable it thus becomes possible, with certain ratios of dimensions, for a certain frequency to be produced by either of two different modes. The vibrator will naturally prefer that mode which is least damped by internal friction, supports, and surroundings, but the alternative mode will remain an interfering influence threatening to predominate should conditions alter.

When a vibrator is made from crystalline, and therefore anisotropic material, the frequency for a given size and mode is affected by the orientation of the piece in the parent crystal. If, as with quartz, the vibrations are maintained piezo-electrically, then the directional nature of the piezo-electric effect introduces a further factor affecting performance. For example, in pieces of quartz cut at some angles, a chosen mode may be excited by such a small piezo-electric component that it is liable to be upset by nearby more strongly excited interfering modes.

The properties of quartz crystal vibrators change with temperature, and the rates of change of different properties vary. Thus, the frequency of an inherent unwanted vibration may rapidly approach the frequency of the required mode as the temperature alters, until finally interference occurs. These then are some of the factors which the crystal manufacturer must consider.

Crystal Equivalent Circuit.

The end product of the quartz crystal manufacturer is (usually) a two-terminal circuit component and as such should allow of description in normal circuit terminology. The familiar concept of an equivalent circuit can readily be applied to the quartz vibrator, and this in its simplest form for a single response is shown in Fig 1 (a).

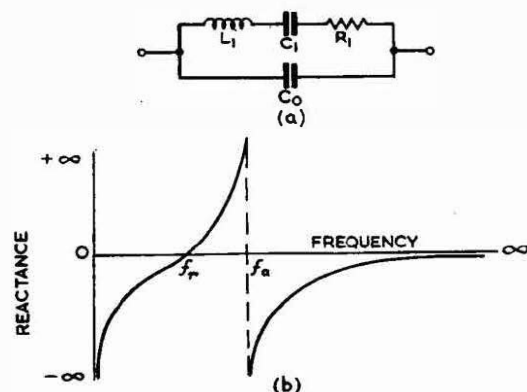

FIG. 1.—SIMPLE EQUIVALENT CIRCUIT AND REACTANCE/FREQUENCY CHARACTERISTIC FOR CRYSTAL VIBRATOR.

† Executive Engineer, Radio Experimental and Development Branch, E.-in.-C.'s Office.

The series arm $L_1 C_1 R_1$ is by itself an inadequate representation because to apply and collect piezo-electric charges the crystal has electrodes, and thus a capacitor is formed of capacitance C_0 . Fig. 1(b) shows the reactance/frequency characteristic of this equivalent circuit. At low frequencies the circuit is capacitive. At the frequency, f_r , at which L_1 resonates in series with C_1 , the reactance of C_0 is much greater in magnitude than the value of R_1 and it is sufficiently accurate to regard R_1 as the series resonant resistance of the vibrator when connected into a low-impedance circuit. This value of resistance is usually referred to as equivalent series resistance (E.S.R.). At frequencies immediately higher than f_r , the equivalent circuit has an inductive reactance rising rapidly to a very high value as $L_1 C_1 C_0$ approach parallel resonance at frequency f_a . Equating reactances, at parallel and series resonance respectively,

$$2\pi f_a L_1 - \frac{1}{2\pi f_a C_1} = \frac{1}{2\pi f_a C_0} \dots\dots\dots(1)$$

$$\text{and } 2\pi f_r L_1 = \frac{1}{2\pi f_r C_1} \dots\dots\dots(2)$$

$$\text{From (2), } L_1 = \frac{1}{(2\pi f_r)^2 C_1}$$

and substituting this value in (1),

$$\frac{2\pi f_a}{(2\pi f_r)^2 C_1} - \frac{1}{2\pi f_a C_1} = \frac{1}{2\pi f_a C_0}$$

$$\text{from which, } \frac{C_1}{C_0} = \frac{f_a^2 - f_r^2}{f_r^2} = \left(\frac{f_a}{f_r}\right)^2 - 1$$

As a property of quartz, C_1 is always small compared with C_0 , from which it follows that f_a is only slightly greater than f_r .

The parallel impedance is

$$Z_o = \frac{L_1}{C_0 R_1} \text{ (very nearly)}$$

$$= \frac{1}{4\pi^2 f_a^2 C_0^2 R_1}$$

If a circuit capacitance C_x is added externally in parallel with the crystal the expression for Z_o becomes

$$Z'_o = \frac{1}{4\pi^2 f_a^2 (C_0 + C_x)^2 R_1}$$

and this quantity is called the equivalent parallel resistance (E.P.R.) of the crystal when associated with load capacitance C_x .

This is the usual treatment of the series and parallel resonant applications of the quartz crystal vibrator for a single response. It is important to remember this premise, for as has already been explained there are many possible ways in which spurious responses can arise, each of which could be represented by a further parallel branch $L_2 C_2 R_2, L_3 C_3 R_3$, etc., added to the equivalent circuit shown in Fig. 1. If the vibrator is to be used for frequency generation only, the crystal manufacturer has some choice of dimensions and can perhaps adjust matters so as to produce only the required response by arranging for R_2, R_3 , etc., to be high and/or that $L_2 C_2, L_3 C_3$, etc., tune to frequencies outside the range of interest. The designer of the crystal oscillator fixes the range of interest and it follows that he should have a good understanding of crystal parameters if the manufacturer is not to be unnecessarily restricted. If, however, the crystal is to be used for frequency selection in a filter, its dimensions are fixed by the filter design. The crystal manufacturer has in consequence no choice in the matter and must confine himself to diminishing the effect of any relevant parallel branches and enhancing the effect of the main series arm

by employing the most suitable mounting methods. This having been done, it is sufficient for most design purposes to use the simple circuit equivalents.

Other Parameters.

The frequency/temperature characteristic of a quartz crystal vibrator may be substantially linear, parabolic, cubic, or not in accordance with any simple law, according to the type of vibrator. All four types of characteristic are met with in current production; the linear one in filter crystal work where the vibrator is designed to be free from unwanted responses rather than of low frequency-temperature coefficient; the parabolic characteristic in most oscillator control applications below 500 kc/s; the cubic characteristic in a few special cases such as standards of frequency and time, and the "non-regular" characteristic for most crystal vibrators having fundamental frequencies above 500 kc/s. Crystal vibrators loosely referred to as having zero temperature-coefficient, or low temperature-coefficient of frequency have characteristics of the second or fourth types referred to and are the most common. Fig. 2(a)

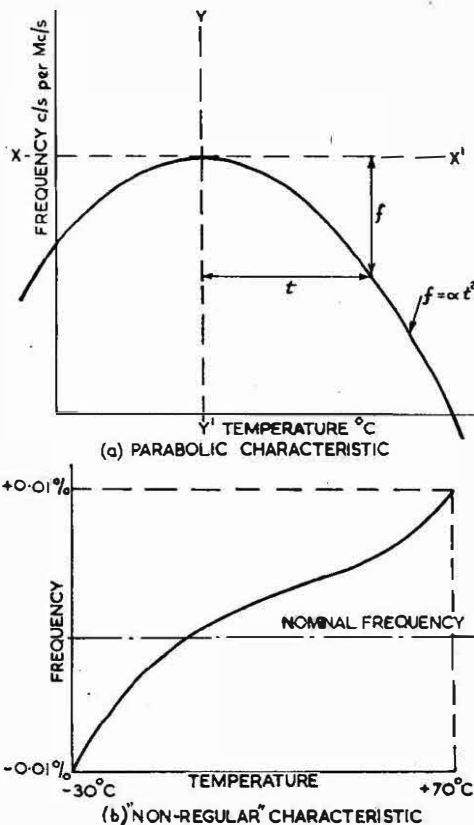

FIG. 2.—FREQUENCY/TEMPERATURE CHARACTERISTICS OF QUARTZ CRYSTAL VIBRATORS.

shows a parabolic characteristic ($f = \alpha t^2$), f and t being measured from axes XX' and YY' passing through the apex of the parabola. It can be arranged during manufacture that the apex occurs at the operating temperature of the crystal vibrator, provided that this is between 10°C and 50°C , and if the units of f and t are cycles per megacycle and $^\circ\text{C}$, respectively, then α will not exceed 0.06 .

Fig. 2 (b) shows a typical "non-regular" frequency-temperature characteristic. As there is no simple equation to this curve it is usual to describe the relationship in terms of percentage frequency variation about nominal, over a given temperature range—in the example ± 0.01 per cent. frequency change between -30°C and $+70^\circ\text{C}$.

TABLE 1
Typical Parameters of Quartz Vibrators.

Frequency range kc/s	Mode of vibration	Type of vibrator	L_1	C_1	E.S.R. R_1	C_0	$Q = \frac{2\pi f_r L_1}{R_1}$	Frequency-temperature relationship	E.P.R. Z_{e1} k Ω ($Cx=30\mu\mu F$)	Typical applications	
			H	$\mu\mu F$	Ω	$\mu\mu F$	$= \frac{1}{2\pi f_r C_1 R_1}$				
1-12	Flexural	Bar	800,000	0.008	400,000	15	23,600	$x = -0.05$	Can be calculated if required $\frac{1}{4\pi^2 f_r^2 (C_0 + 30\mu\mu F)}$	Clocks, counters and carrier generators	
		Gapped ring	7,300,000	0.0015	250,000	10	273,000	$x = -0.1$			
50-150	Longitudinal	Bar	20	0.125	100	25	125,000	$x = -0.1$		Telephony, clocks, sub-standards and primary standards	
	Face Shear	Square plate	31.2	0.081	130	34	150,000	$x = -0.06$			
260-500	Face shear	"Circular"	50	0.05	30	13	1,050,000	$x = -0.03$		Telephony and coastal shipping	
		Square plate	20	0.06	500	13	100,000	$x = -0.06$			
500-1500	Thickness shear	Bevelled disc	5	0.06	100	3.5	250,000	$\pm 0.001\%$ 20°-60°C		300-100	Substandards
2,500-15,000	Thickness shear	Square and circular plates	0.13	0.02	54	8	45,000	$\pm 0.005\%$ 0°-60°C		100-16	Radio transmitter control
80,000-40,000	Overtone thickness shear	Circular plates	Measuring technique not fully developed		30	8	—	$\pm 0.01\%$ 0°-60°C		Can be calculated	Radio transmitter control

The current-carrying capacity of quartz vibrators is sometimes queried by circuit designers. There is some agreement on a breaking current of 16 to 24 milliamps per centimetre of width for the type of plate most used in telephone filters, but the old saying, that a crystal is a source of frequency not power, is a very true one, and measurements have shown that frequency and stability are affected by the power dissipated in the crystal. Generalisation on this subject is perhaps unwise, but for normal applications in communications between fixed stations crystals should not be required to dissipate more than a milliwatt, and in reference standards not more than a few microwatts; frequency ageing rates of crystals thus properly used are measured in parts in a million per year and parts in a hundred million per year, respectively.

Not least in importance to the potential user is a knowledge of the size and shape of the crystal unit and details of its fixing centres and connections. The preferred standard form made in the Engineering Department is a glass bulb $1\frac{1}{8}$ in. diameter, and 2 to 3 in. long either mounted on an octal base with the crystal connected to pins 2 and 8, or clip-mounted with the leads brought out for wiring direct into circuit. Smaller glass envelopes can be used for the smaller crystals but they are always more expensive and sometimes impose undesirable limitations on crystal-manufacturing processes. Larger containers are necessary for some crystals for frequencies below 2 kc/s, and for 100 kc/s primary standards.

Table of Typical Values.

Table 1 shows typical parameters of quartz vibrators designed for use in the frequency range 1 kc/s to 40,000 kc/s. All the values given have been obtained from items which are repeatable. The frequency range has been split into preferred bands in which it is known that quartz crystal vibrators of good all-round performance can be made economically.

From the table can be abstracted the following range of equivalent circuit values for quartz vibrators (it should be remembered, of course, that values cannot be coupled together at will).

- L_1 0.13 H to 7,300,000 H
- C_1 0.0015 $\mu\mu F$ to 0.125 $\mu\mu F$
- C_0 3.5 $\mu\mu F$ to 34 $\mu\mu F$
- R_1 30 Ω to 400,000 Ω
- Q 23,600 to 1,050,000

Considering these in sequence it is of interest to note that equivalent inductance can run into millions of henries, the values of series capacitance being in general much less than 1 $\mu\mu F$. The range of C_0 is more prosaic as would be expected since we are merely concerned here with making quartz dielectric capacitors not differing by many orders amongst themselves in plate area or spacing. Variation in R_1 does not seem very remarkable until considered with corresponding values of L_1 and C_1 , to yield Q values of more than a million. From such figures it can readily be shown that a high- Q crystal can continue to vibrate appreciably for many seconds after the electrical driving forces have been removed.

Bibliography

The list which follows is a short selection of references in which quartz crystals are discussed as circuit elements. The references themselves, in particular the first given, contain many further references of interest.

P. Vigoureux and C. F. Booth. 1950. "Quartz Vibrators and their Applications." H.M. Stationery Office, London.

C. F. Booth and J. L. Creighton. 1946. "Piezo-Electric Quartz and its Use in Telecommunications." I.P.O.E.E. Printed Paper No. 191.

J. L. Creighton, H. B. Law and R. J. Turner. 1947. "Crystal Oscillators and their Application to Radio Transmitter Control." I.E.E. Journal, Part IIIA, 94, 331.

R. L. Corke. 1945. "Crystal Filters." P.O.E.E.J., Vol. 37, p. 113. Vol. 38, pp. 7, 39 and 76.

Miniaturised Testing Equipment for Cable and Pair Identification

W. L. SURMAN, A.M.I.E.E., and
G. W. THOMAS†

U.D.C. 621.315.29

For apparatus to be used in locating cable tracks and identifying particular cable pairs portability is an important requirement. The authors describe equipment of miniature type, designed with this requirement in mind, and outline the method of use.

Introduction.

THE improvement of methods for the location of buried cables and pairs in cables has actively concerned the Post Office for many years, and apparatus has been developed from time to time to meet the several requirements. These requirements can be divided into two main groups, (a) the location of buried cables or the selection of one of several cables of similar appearance in a jointing chamber and (b) the selection of a particular pair of wires in a cable.

Since the labour costs involved in these searches are very high, any improvements in the methods used will result in considerable savings.

Existing Methods.

The methods at present in use for the location of cables employ a Tester SA 9001 with a search coil, or a Tester SA 9077 with a probe or a search coil. With the Tester SA 9001 an A.C. source, provided by a reed generator, is connected between earth and the spare wires in the cable to be located, and by means of the search coil the track taken by the cable can be located and followed. The action when using the Tester SA 9077 is similar except that the tone source consists of a quenched oscillator of 1,000 c/s applied to one pair, the cable being located by a search coil or identified by an inductive probe.

The identification of a pair in a cable is achieved either by the use of a battery and detector (or buzzer and headgear receiver), or by the Tester SA 9003¹ which consists of a single valve amplifier and an A.C. source such as a reed generator or a small acoustically coupled oscillator. The A.C. source is connected to the pair to be located and the tone is picked up by an electrostatic probe, amplified, and detected by headphones.

All the apparatus used in the audio methods of location is fairly bulky and probably its weight alone discourages the more general use of the equipment. It was decided, therefore, that a unit based on existing designs should be produced to cover all the needs mentioned above, with a consequent reduction in the number of types of tester required, and that by miniaturisation such a tester could be made less bulky and so be a very convenient instrument for use in the field.

Design Considerations.

It was apparent that the physical dimensions of the existing testers could not be reduced appreciably unless some material other than wood was used for the cases; aluminium naturally appeared the most suitable choice both from the point of view of lightness and freedom from corrosion, particularly as modern manufacturing techniques of spot-welding aluminium have solved many of the difficulties of fabrication of this material.

The existing headphones are rather cumbersome, although very efficient, and it was decided to use a single earpiece receiver of the type in use for "external" hearing aids. The use of miniature valves of high efficiency enabled

the physical dimensions of the tester to be reduced further, especially as the low current consumption made the use of small H.T. and L.T. batteries possible.

As the tester is intended to be used in conjunction with various tone sources, it was necessary for a fairly wide-band amplification to be available. It was also desirable to have a filter incorporated to enable a particular tone to be identified under electrically noisy conditions, the filter being connected so that it could be switched in or out at will. It was evident that a filter unit of the conventional type having inductors and capacitors would be bulky and the parallel-T resistance/capacitance network was considered the most suitable.

This type of filter relies for its action on selective negative feedback, and consists of resistors and capacitors connected as shown in Fig. 1.

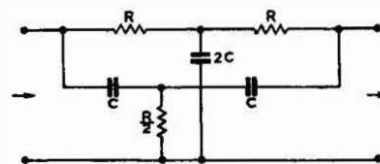

FIG. 1.—CONNECTIONS OF PARALLEL-T RESISTANCE/CAPACITANCE FILTER.

In this filter, at a frequency f_0 which is equal to $1/2\pi CR$ there is very high attenuation between the input and output and it will be clear that if a negative feedback path is provided by a filter of this type the feedback at the critical frequency f_0 will be very small and will rise as frequencies diverge from the critical frequency.

Description of Apparatus.

The new testing equipment consists of an amplifier (Amplifier No. 55A) which can be used with either electrostatic or inductive probes or a search coil of the frame aerial type, a light headgear receiver and two oscillators, one giving a relatively low output of the order of 30 mW at 1,000 c/s for use in pair location (Oscillator No. 24A) and a quenched oscillator of higher output power for cable location (Oscillator No. 23A). Oscillator No. 24A is an existing item and has not yet been redesigned in miniature form.

The amplifier is contained in an aluminium case 6 in. \times 5 in. \times 4 in. This case has been standardised for the amplifier, and for the quenched oscillator, thereby taking advantage of unit construction principles. The case is in the form of an open box having a hinged side, the lid of the case being integral with, and supporting the particular unit contained in the box. A partition extending half way down the box gives rigidity and in the amplifier forms a compartment (visible when the hinged side is opened) to contain the headgear receiver and an electrostatic probe. A loose container fitted in the bottom of the box holds three dry cells of the U2 type and this container is held in place by the H.T. battery on one side and the amplifier framework on the top. The lid forming the chassis is held in place by a single captive screw with a coin slot in the head. The three valves are mounted side-by-side on a web extending from

† The authors are, respectively, Executive Engineer and Assistant Engineer, Subscribers' Apparatus and Miscellaneous Services Branch, E.-in-C.'s Office.

¹ P.O.E.E.J., Vol. 34, p. 169.

the lid, which also supports the output transformer. The resistors and capacitors are of the miniature type.

The lid of the amplifier forms the control panel and contains two sockets, for headphones and input circuits, respectively. The headphone socket is a four-pin type, its two spare connections being included in the L.T. circuit to disconnect the battery when the plug is removed and so

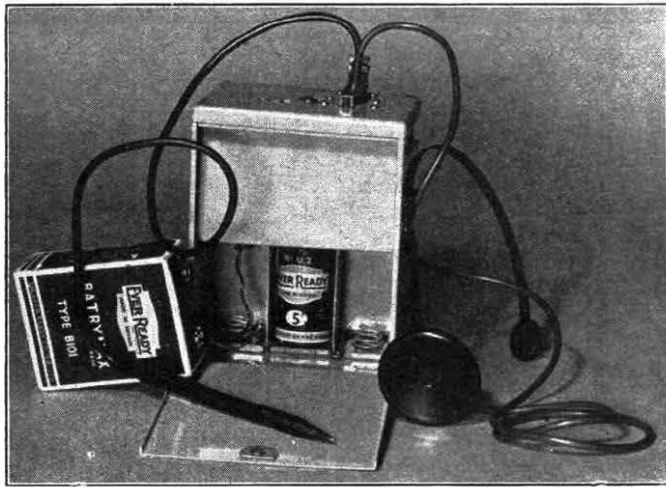

FIG. 2.—THE AMPLIFIER WITH PROBE AND RECEIVER.

avoid the set being packed away inadvertently in the operated condition. The input is a coaxial socket as it is necessary to screen the input circuit completely to avoid positive feed back. A single knob operates the gain control and two switches are fitted, one an on/off switch, and the other controlling the filter circuit. Fig. 2 gives a general view of the amplifier and Fig. 3 the components unit.

In Fig. 4 the amplifier is shown side-by-side with the Testers SA 9077 and SA 9003, which it

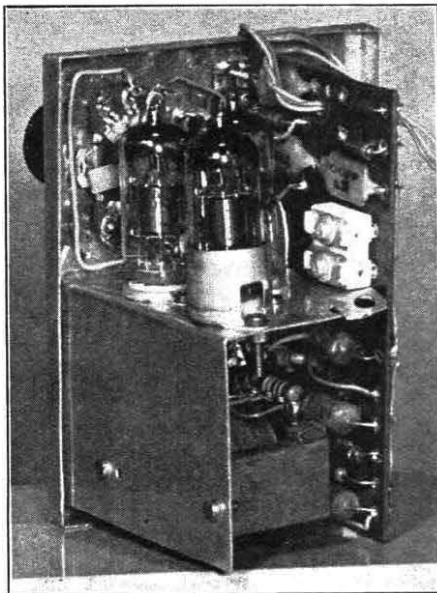

FIG. 3.—THE AMPLIFIER COMPONENTS UNIT.



FIG. 4.—THE AMPLIFIER COMPARED WITH TESTERS SA 9077 AND SA 9003.

supersedes. A circuit diagram is given in Fig. 5. It will be seen that a spare position exists in the filter switch S1 and a small crystal microphone may be fitted in the amplifier at a later date to enable two-way conversation to be carried on when cable pair locations are being made.

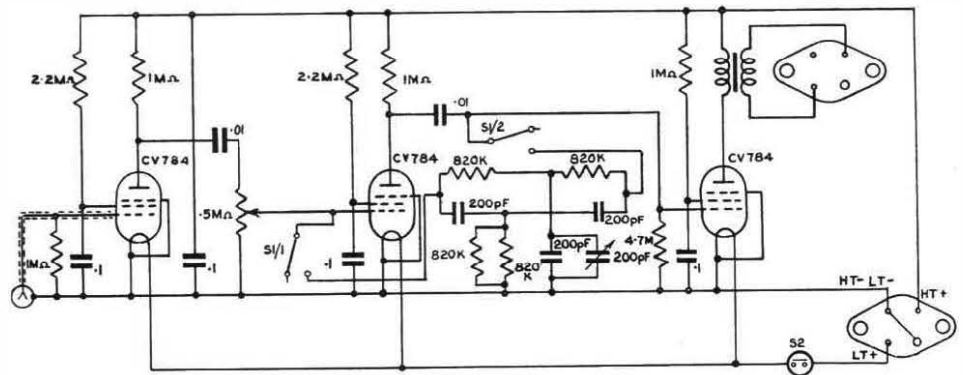

FIG. 5.—CIRCUIT DIAGRAM OF THE AMPLIFIER.

The electrostatic probe (Probe No. 5) consists of a length of coaxially screened flexible cord, at the end of which the centre conductor is extended past the screening and bent back over it. A small metal tip is soldered to the point of bending and the whole moulded in polyvinyl chloride. A longitudinal flat on one side is adjacent to the conductor and the complete probe approximates to the shape of a propelling pencil. The screening of the cord acts as a transverse electrostatic shield and makes the probe very directional in effect. By using a P.V.C. moulding the probe is rendered fairly free from accidental damage and can be distorted, dropped, or trodden on without ill effects. The other end of the cable forming the probe is terminated in a coaxial plug.

The headgear receiver (Receiver, Headgear, No. 10S) is the same type as fitted to the Medresco hearing aid, except that the method of connection has been altered and a more robust cord fitted. The cordage consists of 25 strands of 0.004 in. diameter wire insulated with P.V.C., twinned, and finally extruded with a sheath of P.V.C. The headgear end of the cord terminates in a slotted ferrule which is bound to the cord and an overall moulding of P.V.C. is applied. Two lips in the ferrule slide into the guides of the receiver which normally accommodate the connection plug, and the two leads are extended inside the receiver and

solder-connected. At the amplifier end of the cord a four-pin plug is moulded in P.V.C., the two spare pins being strapped together to provide a battery switch rendering the set inoperative when the plug is removed. This plug, like the probe, can be distorted and subjected to rough usage without damage.

The quenched oscillator has been included in a box of construction similar to that of the amplifier. The power equipment, which is mains-operated, is contained in the lower half of the box and consists of a mains transformer with a half-wave rectifier to supply H.T. of approximately 20 mA at 200V. The oscillator contains two valves, one being a CV133 miniature triode connected as a close-coupled tuned grid oscillator, the grid leak and capacitor having values such that the oscillator is self-quenching at a rate controlled by a variable resistor. This valve is transformer coupled to a CV858 double triode connected in push-pull. The output transformer has two ratios, for use when the oscillator is connected to a pair or between cable and earth. A diagram of the oscillator is given in Fig. 6.

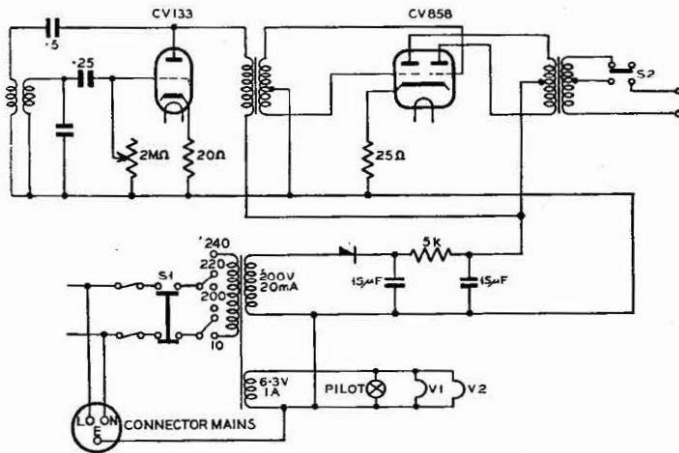

FIG. 6.—CIRCUIT DIAGRAM OF THE OSCILLATOR NO. 23A.

A strap and button fixed to the sides of the case enable a standard carrying strap to be used to sling the amplifier or oscillator over the shoulder. A canvas carrying case has also been designed which will take either the amplifier or the oscillator and includes a compartment for the accommodation of headphone, probes, leads, etc. At a later date it is proposed to provide a lightweight carrying case to hold several different units and thus provide a self-contained testing set which is readily transportable.

Book Review

"Integral Transforms in Mathematical Physics." C. J. Tranter, M.A. Methuen (Monograph series), London. 118 pp. 7 ill. 6s.

This monograph gives an outline of the use of integral transforms for solving problems described by partial differential equations with assigned boundary and initial conditions. The method of integral transforms had its origin in the work of Heaviside (1850-1925) and has certain advantages over the classical method derived from the work of Fourier (1758-1830). Heaviside applied his method to those partial differential equations which arose in transmission problems; and its power was such that he solved many hitherto intractable problems and obtained solutions to problems already solved, in a form better adapted for numerical calculation. Later investigations by Bromwich, Carson and van der Pol have placed Heaviside's integral transform ideas on a rigorous mathematical foundation.

The author of this monograph shows with remarkable ease and brevity that the solution found from Heaviside's calculus is obtained from Laplace's integral equation, and the

Use of Equipment.

(a) *Cable pair location.* Depending on the distance to the point at which location is desired, an Oscillator No. 23A or 24A is connected to the required pair. The probe is inserted into the open joint and by rotation the group of wires containing the wanted pair can be identified; this will be the group on the side of the probe having the flat. This process of selection of a group is continued until the wanted pair is found, when the exposed tip of the probe can be touched against the pair to give a clear indication.

An alternative, and in most cases a faster, method of working is to grip a single pair or a bunch of pairs between the finger tips of both hands with the probe strapped to the wrist or inserted in the breast pocket. In earlier experiments, the input was connected to a metal pad on the headgear receiver band, but it was found that the received signal strength varied with the condition of the finger tips, and the use of a probe was found to be necessary.

(b) *Cable track location.* The Oscillator No. 23A is connected between a pair and earth at one end, the far end of the pair being earthed. The amplifier is then used with a magnetic probe or search coil and the position of the track can be ascertained by listening for the point of maximum sound.

(c) *Disconnected or short-circuited pairs.* The Oscillator No. 23A is connected to the pair in question and the cable is followed using the magnetic probe. At the point at which the tone disappears or diminishes greatly the fault will be found. This method has not proved wholly successful for pairs with only one wire disconnected.

Conclusion.

It is not claimed that the equipment has been accommodated in the smallest possible space, as the dimensions have been chosen to allow for the storage of the headgear receiver and probe and for adequate L.T. and H.T. battery capacity. The use of this equipment is not indispensable for cable and cable pair location, but will be found of great assistance where the number of conductors makes identification of a particular pair difficult and in the location of short-circuits and disconnections in non-ferrous and sheathed cables. It is considered that the apparatus described will be a definite help to all those engaged on cable work, and its portability should encourage wider use, with consequent reduction of time spent in tracing missing pairs.

The authors wish to acknowledge the help given by Mr. P. T. Mercer in the preparation of the photographs.

contour integral appearing in Bromwich's work is the integral in the inversion theorem for the Laplace transform. An engineer reading this monograph will rejoice in its brevity and directness; but a mathematician may not feel so happy, for some of the proofs leave much to be desired from the viewpoint of rigour.

The author shows clearly that the Laplace transform is particularly suitable for use in the solution of problems described by ordinary differential equations, but other integral transforms, such as those due to Hankel and Mellin, may be much more convenient for use in the solution of boundary value problems described by partial differential equations. Several different integral transforms are described, but no mention is made of Hilbert or Stiltje transforms, or those queer topological impulsive transforms used by Heaviside without proof; the author does point out, however, that there is no reason why the calculus he describes should not be extended by the use of special kernels.

This monograph is a valuable addition to the literature of the subject: it is very clearly written and can be recommended to those engineers who enjoy good mathematical reading.

H. J. J.

Sir Archibald J. Gill, B.Sc.(Eng.), M.I.E.E., F.I.R.E.



(Lafayette)

SIR ARCHIBALD GILL, who retired on 1st October from the post of Assistant Director-General and Engineer-in-Chief, received his early engineering training as a pupil with Yarrow & Co., Ltd., engineers and shipbuilders, followed by a period with the British Thomson Houston Company on the design of steam turbines. Not unnaturally he has retained an intense interest in all things connected with ships. The Post Office has been fortunate in his being able to express this in the design of H.M.T.S. "Monarch" and its other cable ships for which he was so largely responsible. His personal interest in the "Monarch" and his extensive knowledge of electrical engineering developments led to numerous interesting innovations in the design of that vessel. In particular the cable paying-out and picking-up machines, as well as the windlass and capstans, are all operated as a constant-current system with amplidyne control. There can be little doubt that the "Monarch" is the largest and best equipped ship of its kind in the world.

Entering the Post Office through the Open Competition as an Assistant Engineer (Old Style) early in 1913, Sir Archibald was appointed to the Radio Branch (then the Wireless Section). He took a prominent part in the design

and construction of the Leafield and Rugby Radio Stations, and was the first (Senior) Executive Engineer to take the Radio Branch Laboratories at Dollis Hill as his sole responsibility, laying the foundation so well that these laboratories duly developed into a separate branch (WE) of their own. After becoming Staff Engineer in charge of the Radio Branch in December, 1932, he was promoted Assistant Engineer-in-Chief in July, 1938. During this period he was largely responsible for the equipping of the first coaxial cable in Britain. Thus in some twenty-five years' service in the Radio Branch Sir Archibald covered a very wide field of high-frequency development, starting from the use of simple crystal detectors and spark transmission. With characteristic humour Sir Archibald now maintains that the modern radio engineer with his crystal diodes and pulse transmission has just reached the point from which he himself started so many years earlier.

Little may be said of Sir Archibald's many and varied adventures during the war, except that he played a large part in the planning and construction of various deep-level tunnels which were made to safeguard communications; that under his guidance a number of new radio transmitting and receiving stations were erected; and that he also found time to apply himself to many other activities on behalf of the fighting and other Services, such as, for example, the provision of plant for the laying of the "Pluto" oil pipes.

It came as no surprise when Sir Archibald succeeded Sir Stanley Angwin as Assistant Director-General and Engineer-in-Chief in January, 1947, having closely shadowed Sir Stanley for so many years, and his many friends were delighted to read of his Knighthood in the New Year's Honours List of 1949. During these last few years he has taken particular interest in the provision of the most modern forms of telephone cable, both land and submarine, and of the special facilities for the extension of the television programme network to the provinces; he was also much concerned over the preparation of many of the clauses relating to the Wireless Telegraphy Act, 1949.

Sir Archibald is well known internationally. He has visited many foreign countries for technical discussions between administrations, and in the course of radio conferences of the I.T.U. It is interesting to recall that one of his earliest visits was to the United States in 1927, in connection with the establishment of the first transatlantic telephone circuit.

Sir Archibald, who is the retiring President of the Institution of Electrical Engineers, and a past Chairman of the Radio Section of that Institution, has also served as a member of the Radio Research Board. He is also a Fellow of the Institution of Radio Engineers of America. It was doubtless much to his liking that in his year of office as President he should be called upon to present a paper on "Applications of Electricity to Sea Transport," at the Joint Engineering Conference of the three main Institutions, civil, mechanical and electrical.

Endowed with the rare qualities of an unusually fertile mind which produces a continuous flow of new ideas, an appropriate puckish sense of humour, and a fixed belief that difficulties are only made to be surmounted, Sir Archibald, a born engineer, will be greatly missed by his colleagues both engineering and administrative. He carries with him the good wishes of all his colleagues in his retirement.

A. H. M.

W. G. RADLEY, C.B.E., Ph.D.(Eng.), M.I.E.E.



THE appointment of Dr. W. G. Radley to succeed Sir Archibald Gill as Engineer-in-Chief is welcomed by his many colleagues both within and outside the Post Office. The extent of his activities in the wider field of service is indicated by the various commitments he has undertaken from time to time. He is chairman of the Materials Committee of the Radio Research Board. During the war he was chairman of the Electro-Acoustics Sub-Committee of the Ministry of Supply on work concerned with improvements of communications in armoured vehicles, and was a member of the Radar and Signals Advisory Board. He was chairman of the committee, formed in 1944, to advise the Medical Research Council on the design and application of electro-acoustic apparatus for the alleviation of deafness, throughout the initial, certainly the most difficult, and probably the most successful period of its existence. He has also served as a member of the Council of the Electrical Research Association and as a member of many technical and inter-departmental committees, as a member of Council of the I.E.E. and as chairman of its Measurements Section; he has been elected Vice-President of the I.E.E. for the forthcoming year. He has represented the British Post Office at meetings of the C.C.I.F. on no less than three of its committees, those concerned with protection against power systems, corrosion and switching.

It is, however, as a member of the Research Branch that Dr. Radley is best known to us. Joining as a temporary Inspector in 1920, he left the Branch 29 years later to take over duties of a more administrative character at Alder House. Before joining he had served with the Royal Engineers in the first world war, had won the silver and gold medals at Faraday House, and had been apprenticed in heavy electrical engineering at Bruce Peebles, Ltd., of Edinburgh. He was with the first contingent of the Research Section (as it then was) to move to Dollis Hill in 1921 and, in the following year, he was successful in the first post-war competition for Assistant Engineers (now designated Executive Engineers).

The Materials Group of the Research Section, to which Dr. Radley was posted, and of which he later took charge, offered opportunities for mastering different problems, each requiring highly specialised, but quite different, methods of technique and mental approach. It is the rare capacity for doing just this, and doing it efficiently, that is one of the outstanding characteristics of the man. In his early work on magnetic and dielectric materials he made use of the (then new) X-ray diffraction methods of studying the structure of materials. His work in co-operation with the Electrical Research Association on interference from power on telephone lines came at the time when the grid system was under construction and included the experiments which confirmed the basis for the calculations of interference effects. For this work he was awarded the Ph.D. degree by London University in 1934. At the same time he was engaged on problems of corrosion of cables and was invited to address a conference on corrosion in Washington in 1937. These investigations of both interference and corrosion required a considerable amount of work to be done on site; they provided opportunities for gaining first-hand experience of the telephone network, above and below ground. As Assistant Staff Engineer at the time when the 2 V.F. system was being introduced, he contributed substantially to the development of long-distance signalling and dialling. More recently he has played an active part in the studies by the C.C.I.F. of signalling and switching over international telephone circuits and in the arrangements for the forthcoming international field trial.

For more than 10 years, from 1939 when he was appointed Staff Engineer, Dr. Radley was in charge of the Research Branch, finally as Controller of Research and a Deputy Engineer-in-Chief. This statement gives perhaps as clear an indication as is possible (so near the event) of the increased value of the work of the Branch during his leadership. The times were not normal and the responsibilities, both technical and administrative, which were carried by Dr. Radley were heavy. Prior to the formation of the Training Branch in 1946, he was responsible for engineering training, and he guided the project which has materialised as the school at Stone. He is the author of many technical papers and has been awarded both the Ferranti and the Fahie premiums of the I.E.E. It is characteristic that he was actively interested in the social activities at Dollis Hill; in this he was ably seconded by his wife (herself the daughter of a Staff Engineer) who holds the affectionate regard of the Branch.

A character of seemingly untiring energy, which spares least of all himself, and of great personal charm, Dr. Radley has achieved much, and we wish him success and well-being in his new appointment.

W. W.

The VIth Plenary Meeting of the C.C.I.R., Geneva, June, 1951

U.D.C. 061.3: 621.396.

It is of interest to recall that at the Vth Plenary Meeting of the C.C.I.R.,¹ held at Stockholm in 1948, decisions of great importance to the future of the C.C.I.R. were taken. At that meeting a full-time Director, Dr. van der Pol, and Vice-Director, Mr. L. W. Hayes, were elected, and a permanent Secretariat was set up. In addition, a large programme of studies was approved and allocated among 13 new Study Groups, each set up under an International Chairman. These Study Groups were concerned with questions dealing with Radio Transmitters (S.G.1), Radio Receivers (S.G.2), Complete Radio Systems (S.G.3), Ground Wave Propagation (S.G.4), Tropospheric Propagation (S.G.5), Ionospheric Propagation (S.G.6), Time Signals and Standard Frequencies (S.G.7), Monitoring (S.G.8), General Technical Questions (S.G.9), Broadcasting (S.G.10), Television (S.G.11), Broadcasting in Tropical Zones (S.G.12) and Operational Questions depending on technical factors (S.G.13).

Immediately following the Vth C.C.I.R., National Study Groups were set up within the United Kingdom to carry out studies and to make technical recommendations to the International Chairmen of the Study Groups preparatory to the VIth C.C.I.R. As a result of these studies, contributions were submitted on the great majority of the questions. In all, a total of 58 contributions were made out of some 250 documents that were either distributed to members as preparatory documents some months before the start of the VIth C.C.I.R. or were distributed in the course of the conference. In general, the work of the International Study Groups was conducted by correspondence, but meetings of Study Group 6 (Ionospheric Propagation) and Study Group 10 (Broadcasting) were held in Washington in March, 1950, and of Study Group 11 (Television) in Zurich, 1949, and London, May, 1950. The latter meeting followed a series of television demonstrations in the United States of America, France, the Netherlands and England.

At the Vth Plenary Meeting of the C.C.I.R. it was agreed to hold the next Plenary Meeting in Prague during the spring of 1951, but, subsequently, the Czechoslovakian Administration found that they were unable to accommodate the conference and it was finally decided to hold the VIth Plenary Meeting in Geneva from 4th June to 7th July, 1951.

The U.K. delegation assembled at Geneva for the formal opening of the VIth C.C.I.R. on 5th June. A total of 41 nations were represented at the meeting, some 300 representatives in all, and Mr. Möckli of the Swiss Administration was unanimously elected to the chair. The Conference was held in the *Salle du Conseil Generale* and simultaneous interpretation facilities in four languages were available at Plenary Assembly sessions, at Study Group meetings and at meetings of main committees.

The work of the conference was carried out by a Heads of Delegation, Budget, Drafting and 15 Technical committees with their associated working groups. The 15 Technical committees covered the 13 Study Groups and two were dealing respectively with a new question of the "Theory of Information" and problems arising in connection with Definitions, Nomenclature, Symbols and allied matters. The Technical committees with their working groups met over the period 4th to 27th June and the period 28th June to 6th July was allocated to Plenary meetings concerned with the acceptance of technical recommendations resulting from the studies; the formulation of questions and a study

programme to be carried out before the VIIth C.C.I.R.; the setting up of the necessary Study Groups; the nomination of the International Chairmen; and the time and place of the VIIth C.C.I.R. At the outset of the conference the Drafting Committee gave consideration to the classification of the documents of the VIth Assembly. It was decided to introduce the following categories of documents: Recommendation, Report, Resolution, Question and Study Programme, and the final documents of the conference are classified accordingly. The studies to be carried out for the VIIth C.C.I.R. fall into the categories of a Study Programme or a Question.

It is not possible here to discuss in detail the Study Group work, but some of the more important items that are included in the 51 Recommendations, 39 Study Programmes, 23 Questions, 15 Reports and 9 Resolutions approved by the Plenary Assembly will be outlined.

On radio receivers, the performance which can be achieved at present was summarised and methods of testing performance were examined; in particular, the "selectivity" factor was considered. In connection with radio transmission the necessary minimum bandwidths for various forms of transmission were discussed, methods of bandwidth measurement and of unwanted harmonic radiation were examined, and preferred values of frequency shift for telegraph channels were proposed.

The studies on propagation have resulted in very useful additions to the literature, and study programmes have been laid down where additional information is required. Increasing attention was paid to the transmission of signals of frequencies exceeding 30 Mc/s, a very important factor in connection with the increasing use of these frequencies for single- and multi-channel systems.

Since the Vth meeting, considerable experimental progress has been made with the transmission of standard frequency and time signals, experimental systems having been set up by several countries. The results of this work were analysed and the scope of future work was outlined.

Several questions bearing on marine radio were examined and, in particular, the form of an automatic distress signal for international use was approved.

On broadcasting, recommendations dealing with the maximum power of transmitters, the directivity of aerials, asymmetrical sideband transmission and sound recording systems were examined.

Many of the technical problems met with in television were examined, and, in particular, the degree to which standardisation of systems could be achieved.

At the final Plenary session a study group structure of 14 Study Groups in all, very similar to the existing one, was set up for the preparatory studies to be carried out for the VIIth C.C.I.R., the additional group being formed to consider a Vocabulary of Definitions, Abbreviations, Terms, etc., Decimal Classification, Signs and Symbols and Measurement Units. The nominated International Chairmen included two from the United Kingdom, one taking Study Group 5 and the other Study Group 9. An invitation to hold the VIIth C.C.I.R. in London during 1953 was unanimously approved.

In conclusion, it can be stated that the VIth C.C.I.R. was successful in reaching technical decisions on a wide variety of questions and that, although much remains to be done, the post-war C.C.I.R. is firmly established and will make an increasingly important contribution to radio-communication.

C. F. B.

Notes and Comments

Roll of Honour

The Board of Editors has learnt with deep regret that the following member of the Engineering Department has died whilst serving with the United Nations Forces in Korea:—
 London Telecomms. Region .. Lewis, J. O. .. Technician IIB Corporal, Royal Ulster Rifles

Birthday Honours

The Board of Editors offers its congratulations to the following members of the Engineering Department honoured by H.M. the King in the Birthday Honours List:—

Bristol Telephone Area	Jones, P. McD., M.M.	Technician, Class I	British Empire Medal
Cardiff Telephone Area	Jones, O. H.	Inspector	British Empire Medal
Engineering Department	Leech, Capt. W. H., D.S.C.	Submarine Superintendent	Officer of the Order of the British Empire
Engineering Department	Merritt, Mrs. L. B. V.	Clerical Officer	Member of the Order of the British Empire
Manchester Telephone Area	Holmes, R.	Mech.-in-Charge III	British Empire Medal

Col. J. Reading, M.B.E., B.Sc.(Eng.), M.I.E.E.

Col. J. Reading, who has been promoted to Assistant Engineer-in-Chief, left St. Marylebone Grammar School in 1916 and served with the London Scottish and Royal Engineers (Signals) until the end of the war. He graduated from the Northampton Engineering College, London, in 1924 and after a brief period in industry entered the Equipment Branch of the Engineering Department as a Probationary Assistant Engineer in 1925.



His immediate concern was with the specification of exchange equipments for C.B. manual extensions and for the early Director auto exchanges in London. On his promotion to Executive Engineer in 1934, his influence was immediately felt in the creation of the new Standards Group and he did pioneer work in devising and introducing routed schematic diagrams to replace the complex wiring diagrams previously employed. Being very concerned with the standardisation of graphical symbols for exchange circuits he was made Secretary of the P.O. "Terms and Symbols Committee" (of which he is now Chairman), and has represented the British Post Office and the British Standards Institution on many International Conferences. Promotion to Assistant Staff Engineer in the Equipment Branch followed in 1937.

In 1935, Col. Reading was appointed Managing Editor of this JOURNAL, the circulation of which increased from 10,000 to 17,000 copies per issue during the four years prior to the war. He was also a most active Secretary of the Institution of Post Office Electrical Engineers from 1935 until September this year.

Col. Reading held a commission in the Supplementary Reserve Royal Signals, and went to France on the outbreak of war as a Captain with the L of C Signals Unit. Leaving France via Cherbourg in 1940, he was posted to the Canadian Divisional Signals, and, in 1941, was appointed a Staff Officer (G II Lines) at G.H.Q. Home Forces. In September, 1941, he left for the Middle East as Second-in-Command of 10 Corps Signals, and spent some six months in Syria until appointed Lines Officer at G.H.Q. Middle East. The withdrawal of our forces to Alamein, and the subsequent advance, entailed considerable planning of line communications, for which he was awarded the M.B.E. and twice mentioned in despatches. In 1943 he was promoted Lieut.-Colonel, and later went to Italy as O.C. 15 L of C Signals. He returned to England in 1945 to take up the appointment of Chief Signal Officer, War Office Signals, with the rank of Colonel.

In 1946 he returned to the Equipment Branch, this time as Staff Engineer, and he applied himself vigorously to the problems of post-war reconstruction and development of both exchanges and repeater stations. His achievements in this field have been accompanied by most cordial and smooth working with the manufacturers.

Not the least of John Reading's characteristics is a straightforward manner and a lively sense of humour, both of which are much appreciated and enjoyed by his staff and by his large circle of friends and colleagues, who all wish him every success in his wider sphere of responsibility and influence.

R. W. P.

Journal Price Adjustment

The Board of Editors has decided, regretfully, that with the present high cost of paper and printing it is necessary to increase the price of the Journal to 2s. 6d. per copy commencing with this issue. Particulars regarding the revised annual subscription rate, supply of back numbers, etc., will be found on p. 145.

As a special concession to readers who are employed in the Post Office, Journals will be distributed to them through the Local Agents at 1s. 6d. per copy. This arrangement will be continued for as long as possible but may have to be reviewed if production costs rise still further.

Retirement of Mr. W. F. Boryer, A.R.C.Sc., M.I.E.E.

Mr. W. F. Boryer, first C.R.E., London Postal Region, retired on 1st October, 1951, after 38 years' service in the Engineering Department. After serving as an apprentice in Portsmouth dockyard, he obtained a National Scholarship and pursued his studies at the Royal College of Science. He entered the service as an Assistant Engineer in 1913. During his early service in the Metropolitan Power District, he was responsible for much of the technical work on E.L. and P. for Post Office buildings in the Metropolitan area and was largely concerned with the equipping of the P.O. (London) Railway. Transfer to the London Engineering District followed in 1928, when he turned his attention to underground construction problems and after successive promotions became Regional Engineer in 1938. His specialised knowledge and experience led to his selection in 1939 for duties in connection with the deep tunnelling projects for the safeguarding of telecommunications in London, work in which he was associated with the Consulting Civil Engineer to the Post Office. The successful completion of the schemes was in no small measure due to the energy and drive with which W. F. B. tackled the many problems involved.

He was appointed Assistant Controller (Engineering) in 1944, and to the newly-created post of Chief Regional Engineer, L.P.R. in 1946. Throughout his career Mr. Boryer had deep concern for the welfare of his staff, latterly being Chairman of the L.P.R. Sports Club. His many friends will wish him well in his retirement.

W. T. G.

R. H. Franklin, B.Sc.(Eng.), M.I.E.E.

Mr. Franklin, who has been appointed Staff Engineer, O. Branch, entered the Department as a Probationary Inspector in 1924, and, after a short period at the Research Branch was transferred to the Equipment Branch. He passed the Probationary Asst. Engineers' examination in 1928, and was later transferred to I. Branch, where he was engaged on cable design. He was promoted Executive Engineer in 1936, and appointed to Lines Branch on the provision of Continental circuits and cable maintenance.

At the outbreak of war, he went to France as a Liaison Officer with the French War Office and, in 1940, on his return to England, went to the War Office. In 1942, he was posted to G.H.Q. Signals, Middle East, where he was responsible for laying, loading, and testing 14/40 cables from Cairo to Palestine, and from Cairo to 8th Army Headquarters at Alamein. It was largely due to the good work of his Company that at the time of Alamein communications from G.H.Q. to 8th Army Headquarters were always maintained. He then went to Burma, and became Deputy Chief Signals Officer, Arakan, where he remained until the end of the war.

He was promoted Asst. Staff Engineer in 1942 "in absentia," and from 1945-1949 in the Lines Branch was concerned with trunk network planning and cable provision. During 1950 he attended the Imperial Defence College, and returned to become the Secretary of the Engineering Panel of the Regionalisation Committee. Mr. Franklin is at present on loan to the Air Ministry, where his unique knowledge of the British trunk network will be invaluable.

J. R.

H. Stanesby, M.I.E.E.

Mr. H. Stanesby, who has taken up the post of Staff Engineer in the Radio Development and Experimental Branch at Dollis Hill, has been closely associated with radio work ever since he entered the Dollis Hill Laboratory as a Youth-in-Training in 1924. He was successful in the Inspector competition in 1925 and in the Assistant Engineer competition in 1930, and was promoted to Executive Engineer in 1938 and to Assistant Staff Engineer in 1947. In the early days, Mr. Stanesby was intimately concerned with the first transatlantic radio telephone circuit and with general receiver development. Later, he played an important part in the development of terminal equipment for multi-channel telephone systems over coaxial cables, and specialised particularly on electrical networks and crystal filters. During a three-year period in the City, he was actively concerned with marine radio and radio aids to navigation. More recently, he controlled the team engaged in the development and equipment of the London-Birmingham television cable system.

Mr. Stanesby is a very active member of the Committee of the Radio Section of the Institution of Electrical Engineers. He has always maintained the refreshing enthusiasm for radio which he brought into the Department—his friends hope that he always will—and it must be a source of considerable pleasure to him that he is now responsible for the direction of the Radio Laboratory which he entered as a Youth-in-Training some 27 years ago. All his colleagues will wish him well in his new responsibility.

C. F. B.

N. W. J. Lewis, Ph.D.(Eng.), M.I.E.E.

Recently promoted to Senior Principal Scientific Officer in the Research Branch, Norman Lewis has travelled a varied road before taking up this appointment. Entering the Post Office in 1926 as a Probationary Inspector, he served in the L.E.D. and in the Radio Branch, and in 1931 as a Probationary Assistant Engineer, returned to the L.E.D., this time in the C.T.O. Section. In 1935 he was transferred to the Lines Branch on provision of long-distance circuits and later he became Executive Engineer on this duty. Meanwhile, his part-time academic studies at Northampton Polytechnic were brought to a climax by the award of a Ph.D. degree.

In 1938, Dr. Lewis was given the job of setting up a new group—later to expand into the "War Group"—dealing with telecommunication facilities for defence. With the cessation of hostilities he was again called upon to form a new group, this time for the development and installation of carrier and coaxial systems, but within a year was promoted to Regional Engineer, S. W. Region. Here he made special studies of the statistics of valve failures and the elimination of faulty joints in transmission equipment and, when he was transferred in 1947 to the newly-formed Line Transmission Division of the Research Branch, found himself dealing with two of his old interests—dry-joint detectors and "waveform" transmission systems.

The basic diversity of these two interests and his valuable contributions to the work of the C.C.I.F., 3rd C.E., underline the versatility of a man who is at once a scientist and an engineer; his many friends wish him every success in his new post.

R. J. H.

G. H. Metson, M.C., Ph.D., M.Sc.(Eng.), A.M.I.E.E.

Mr. Metson joined the Post Office as a Youth-in-Training in 1925 and his subsequent career can be divided into four periods. The first eight years were spent at the Dollis Hill Research Laboratories and for some time he was personal assistant to Dr. Radley in the Physics Laboratory where he received his grounding in Research. In 1933 he passed the Probationary Assistant Engineers' Competition and was posted to the Northern Ireland District. Here he spent the second part of his career and obtained a wide experience of field work. It was during this period that he obtained his M.Sc. and Ph.D. degrees at Belfast University.

Metson was called up for service in the Signals as a territorial officer, was sent to France with the B.E.F., and during the evacuation in 1940, was awarded the M.C. for "gallantry during the final stages of the withdrawal from Boulogne Harbour." In Signals he rapidly rose to Lt.-Colonel rank and commanded a Signal Battalion with both the 1st and 8th Armies in Africa and Italy. He ended this third period of his career in the War Office as General Staff Officer, Class 1.

The present period of his career commenced when he was appointed Principal Scientific Officer in charge of the Thermionics Group at Dollis Hill in 1946. Under his able leadership a group working on the fundamentals affecting the life of oxide-cathode valves has been built up and has already acquired an international reputation for its work in this field. His appointment as Senior Principal Scientific Officer in charge of an expanded Thermionics Group is welcomed by all who appreciate the value of the research work that he is leading.

L. E. R.

E. F. H. Gould, A.C.G.I., B.Sc.(Eng.), M.I.E.E.

Mr. Gould, who has been promoted Staff Engineer (O. Branch), received his technical education at the City and Guilds Engineering College and obtained his Associateship and a 1st class honours engineering degree in 1928. After three years with the

I. T. & T. Laboratories Inc., engaged on research work on telecommunication interference and noise problems, he joined Callender's Cable & Construction Co., and from 1931 to 1933 was in charge of a group studying high-voltage power cables.

In 1933, Gould was one of the five Assistant Engineers selected by Special Competition between candidates from industry and was appointed to the Research Branch, where he again took up work on interference and noise and, in addition, studied cable corrosion problems. Promoted to Executive Engineer, Construction Branch in 1937, on the Interference and Protection duty, he spent a short period in the Radio Branch shortly after the outbreak of war, and returned to the Construction Branch in 1941, there being promoted to Assistant Staff Engineer in 1943. Prior to his eventual transfer to O. Branch in 1948, he was selected to attend a 12 months' course at the Imperial Defence College.

Gould's unflinching sense of humour and his gift of quick repartee will be a great asset to him in the particular difficulties which are associated with Organisation and Efficiency work, and his colleagues extend to him best wishes for his continued success.

F. C. M.

A. E. Penney, M.I.E.E.

Mr. A. E. Penney, after a long association with all phases of power work, has been appointed Staff Engineer of the Power Branch in succession to Mr. W. T. Gemmell.

On leaving Sir Joseph Williamson's Mathematical School in 1921, Mr. Penney was apprenticed on heavy power work; he also attended the Medway Technical College, and in 1926 entered the Department as a Probationary Inspector.

He started his Post Office career in the old L.E.D. (Technical Section) on power work, and after passing the Probationary Assistant Engineers' examination in 1929, took charge of the Group. On gaining promotion to Executive Engineer in 1938, he acted as deputy to the Assistant Controller in charge of all engineering services in the recently formed London Postal Region, including the Post Office (London) railway. In 1944, he was promoted to Regional Engineer, L.T.R. and became responsible for telegraph engineering, radio interference problems, provision of equipment for the B.B.C. in connection with outside broadcasts, and power work.

(It is regretted that pressure on space has made it necessary to omit photographs on this occasion. Ed.)

He served as Vice-Chairman of the London Centre of the I.P.O.E.E. in 1949-50, and took a keen interest in the Junior Section of the Institution, acting as Senior Section Liaison Officer until this year. In addition, he has found time to act as Secretary of the S.P.O.E., Chairman of the L.T.R. Rifle Club, and as a keen supporter of a local dramatic society, for whom he provides lighting effects.

His genial personality, quiet humour and direct approach to any problem, will be missed by his L.T.R. associates who wish him a full measure of success in his new sphere.

G. S. B.

R. S. Phillips, M.I.E.E.

Mr. Phillips, who became C.R.E., London Postal Region on the 1st October, 1951, is a product of the Royal Dockyards. He entered the Engineering Department as an Inspector and two years later was appointed Assistant Engineer as a result of Open Competition. For the first ten years of his career, Mr. Phillips worked in the Research Branch on the provision of power supplies and services for the various laboratories, workshops and offices. The period was one of transition from hutments to a more permanent structure, and Mr. Phillips had the satisfaction of seeing completion of at least part of his planning before leaving Dollis Hill for Manchester, in 1934, to take up duty in the Superintending Engineer's Office. Transfer to Leeds followed in 1936 on promotion to Power Engineer in the experimental N.E. Region. Six years later he was promoted to Assistant Staff Engineer in the Power Branch where, since the end of the war, he has specialised in mechanical engineering activities. He has contributed many articles to this Journal and in 1935 was awarded an Institution Medal for his paper on electric lifts. He is also the author of the standard British work on "Electric Lifts."

Notwithstanding the pressure of official work, Mr. Phillips has found time to go fishing and to be expert in fruit growing. He is also a well-known competitor and prize-winner at the Post Office and R.H.S. Shows.

His long experience and detailed knowledge of accommodation services and postal engineering fit him well for his new job in the London Postal Region.

W. T. G.

Institution of Post Office Electrical Engineers

Secretary to the Institution

On his recent promotion to Assistant Engineer-in-Chief, Col. J. Reading, M.B.E., resigned from the position of Secretary to the Institution, having served in this capacity since 1935.

Readers will wish to note that the new Secretary is Mr. H. E. Wilcockson, and that his official address is Engineer-in-Chief's Office, Telegraph Branch, Alder House, Aldersgate Street, London, E.C.1.

President, Junior Section

Mr. H. R. Harbottle, O.B.E., has been nominated as Chairman of the London Centre and it has therefore been necessary to consider the election of a new President of the Junior Section.

Col. C. E. Calveley, O.B.E., accepted nomination for the Presidency, was duly elected, and has now taken up his new duties. Col. Calveley's official address is P.O.E.D. Central Training School, Stone, Stafford.

H. E. WILCOCKSON,
Secretary.

Technical Periodical Circulation

Many complaints are being received concerning delay in circulation or non-receipt of periodicals, and of the tearing out of items of special interest.

Members are requested, therefore, to co-operate in ensuring that periodicals are forwarded promptly and are not mutilated.

W. D. FLORENCE,
Librarian.

Additions to Library

1984 *Application of the Electronic Valve in Radio Receivers and Amplifiers*. Philips Technical Library (Dutch 1950). (Reviewed in *P.O.E.E.J.*, Vol. 44, p. 34.)

1985 *Calculating Instruments and Machines*. D. R. Hartree (Brit. 1950).

Summarises the progress in the development and use of high-speed computing devices.

1986 *Telephony, Vol. II—Automatic Exchange Systems*. J. Atkinson (Brit. 1950). (Reviewed in *P.O.E.E.J.* Vol. 44, p. 24.)

1987 *Fractional Horse-power Motors*. S. F. Philpott (Brit. 1951). Describes the principles, operating characteristics, construction, application, use and maintenance of each type of small motor.

1988 *Probability Theory for Statistical Methods*. F. N. David (Brit. 1949).

Sets out to state and prove in elementary mathematical language those propositions and theorems of the calculus of probability which have been found useful for students in elementary statistics.

1989 *Trigonometry*. A. Page (Brit. 1951).

Designed to cover the requirements of students taking examinations up to the University Scholarship level, and to be of service to those students preparing for Inter. and Final General Degree examinations.

- 1990 *A Text-book of General Physics*. G. R. Noakes (Brit. 1950).
Deals with the principles of Newtonian mechanics and their application to the study of solids, liquids and gases. Intended for those taking physics at Advanced and Scholarship levels, its outlook is experimental rather than mathematical.
- 1991 *The Mechanism of the Watch*. J. Swinburne (Brit. 1950).
Mainly a reprint of a series of articles in the *Horological Journal*, of a critical character.
- 1992 *Wireless Servicing Manual*. W. T. Cocking (Brit. 1950).
Concerned with purely servicing problems—with the location and cure of the defects which can develop in a receiver and its associated equipment.
- 1993 *Cathode-ray Tube Traces*. H. Moss (Brit. 1949). (Reviewed in *P.O.E.E.J.*, Vol. 43, p. 176).
- 1994 *The Elements of Mathematical Analysis, Vol. II*. J. H. Mitchell and M. H. Belz (Brit. 1950).
A course of mathematical analysis which, while adapted to the particular needs of students of science and engineering, is vigorous and on modern lines so far as mathematical principles are concerned. Little previous knowledge is assumed.
- 1995 *XIIIth Plenary Assembly, 1945—C.C.I.F.*
- 1996 *XIVth Plenary Assembly, 1946—C.C.I.F.*
English translations of the Minutes of Meetings.
- 1997 *Handbook on Electroplating*. "Canning" (Brit. 1950).
Intended to serve as a practical guide to those occupied in the practice of metal finishing in all its phases, and to provide a reference book for those so engaged.
- 1998 *Electric Power Stations, Vol. II*. T. H. Carr (Brit. 1951).
Deals with the general principles governing design, construction and operation.
- 1999 *Electromagnetic Problems of Microwave Theory*. H. Motz (Brit. 1951).
Illustrates the methods of analysis by thoroughly worked examples.
- 2000 *Elements of Electronics*. G. Windred (Brit. 1949).
Surveys the growth of electronics from the original discovery of the electron to the modern applications in radar and electro-medicine.
- 2001 *Transmission Lines and Filter Networks*. J. J. Karakash (Amer. 1950).
Primarily an exposition of elementary theory of transmission lines and electric wave filters.
- 1517 *Quartz Vibrators*. P. Vigoureux and C. F. Booth (Brit. 1950). (Reviewed in *P.O.E.E.J.*, Vol. 44, p. 45.)
- 1052 *Motor Manuals, Vol. I. (Automobile engines)*. A. W. Judge (Brit. 1950).
Gives new information on a variety of subjects, such as the new types of two-cycle and sleeve valve engines.
- 2002 *Telecommunications Principles*. R. N. Renton (Brit. 1950). (Reviewed in *P.O.E.E.J.*, Vol. 44, p. 74).
- 2003 *Electromagnetic Waves and Radiating Systems*. E. C. Jordan (Amer. 1950).
Designed to provide a course on electromagnetic radiation and propagation for electrical engineers and physicists, senior and graduate students.
- 2004 *Gas Discharge Lamps*. Funke and Oranje (Dutch 1951). (Reviewed in *P.O.E.E.J.*, Vol. 44, p. 84).
- 2005 *Cosmic Rays*. L. Leprince-Ringuet (Amer. 1950).
A clear account of modern methods of research in cosmic radiations.
- 2006 *Mathematics for Technical Students, Book II*. J. D. N. Gasson (Brit. 1951).
Provides a complete course of study in mathematics for the second year of the National Certificate in mechanical, structural and electrical engineering; revision problems being introduced at each stage.
- 2007 *Modern Fluorescent Lighting*. A. D. S. Atkinson (Brit. 1951).
Covers the latest developments of fluorescent lighting as applied to shops, factories, public buildings and domestic interiors; together with fundamental principles of light, fluorescence and electric discharge, and the principles and operating characteristics of the fluorescent lamp.
- 2008 *Mathematics for Technical Students, Book I*. J. D. N. Gasson (Brit. 1951).
A complete course of study in mathematics for the first year of the National Certificate in mechanical, structural and electrical engineering; revision problems being introduced at each stage.
- 2009 *Railway Signalling and Communications*. Various (Brit. 1946).
Designed to provide for the need of the lineman, installer, inspector, etc., to possess a sound understanding of the principles underlying their work.
- 2010 *Radio Mains Supply Equipment*. E. M. Squire (Brit. 1948).
Written to assist the practical radio man and radio student to become completely conversant with the principles that govern the design and operation of the supply equipment.
- 2011 *The Calculation and Design of Electrical Apparatus*. W. Wilson (Brit. 1941).
Includes the principles upon which the complete design of switchgear, control gear, protective equipment, instruments, and similar apparatus is based.
- 2012 *The Science of Clocks and Watches*. A. L. Rawlings. (Amer. 1948).
Concerned primarily with the scientific principles of horology, but contains enough descriptive matter to be self-contained.
- 2013 *Magnetic Recording*. S. J. Begun (Amer. 1949).
An engineering treatment of what is known to-day of magnetic recording—theory, various types and makes of recorders, their applications, and performance measurements.
- 2014 *Radio Installations*. W. E. Pannett (Brit. 1951).
Provides an account of the principles of design, construction and maintenance of modern radio transmitting and receiving installations.
- 2015 *Geometry*. H. G. Forder (Brit. 1950).
An expository book for the non-specialist, beginning with elementary geometry, treated in a fresh way, it includes discussions of projective, algebraic, non-Euclidean and differential geometry, the general geometry of higher dimensions, and the logical structure of geometrics.
- 2016 *Analytical Geometry*. R. Walker (Brit. 1950).
An introduction to analytical geometry for students having no previous knowledge of the subject; suitable to meet the needs of those preparing for the mathematics papers of the General Certificate of Education at advanced (but not scholarship) level.
- 2017 *A New Calculus (Parts I and II)*. A. W. Siddons,
2018 K. S. Snell and J. B. Morgan (Brit. 1950/51).
Part I is a preliminary course suitable for students in elementary mathematics; Part II gives a course which should be sufficient for the ordinary scientist and engineer.
- 2019 *Statistics, an Intermediate Text-book, Vols. I and II*. N. L. Johnson and H. Tetley (Brit. 1949/50).
Intended primarily for those studying for the statistical sections of the actuarial examinations, although it should be found useful in a considerably wider field. The standard of mathematics assumed is approximately that of the more advanced papers of the Higher School Certificate or of the Advanced or Scholarship papers in the new school examinations. The emphasis is on the statistical, as opposed to the mathematical, aspects of the problems encountered.

W. D. FLORENCE,
Librarian.

Regional Notes

North Eastern Region

RECONSTRUCTION OF TINSLEY BRIDGE, SHEFFIELD

Tinsley Bridge, on the A630 main trunk road from Sheffield to Rotherham and Doncaster, first crosses the railway line to the north at Tinsley Station, and then the Sheffield and South Yorkshire canal. Its reconstruction was started in 1938 and was planned to be carried out in four sections. One section was completed before the war and this consisted of widening on the right hand side in the Sheffield-Rotherham direction, but over the railway only. At that time the Department laid a 12-way duct in the new portion and drew in the cables from Sheffield to a manhole which, on completion of the scheme, will be half-way across the bridge. On the Rotherham side of the bridge a manhole existed on multiple-way ducts. The present job was to clear the gap between these manholes of Post Office plant, to enable the reconstruction of this section of the bridge to be undertaken. During the last year or so, widening and reconstruction of the two sections of the other side of the bridge has been carried out, and when this was completed in May that half of the bridge was opened to traffic and the side on which the Post Office plant lay was closed.

Between the two manholes there were seven cables which had to be interrupted—3 M.U., 2 C.J. and 2 Local. One of these was the Doncaster-Sheffield No. 4 M.U., (4SP40 + 490/20 P.C.Q.T.), a new cable in course of provision by United Telephones & Cables, Ltd. The contractor, therefore, made an extra length for use as an interruption cable and the permanent length is being stored until required. The cables had to be cleared from the bridge within three weeks of the diversion of the traffic, and it is expected that the bridge will be completed by the end of December, 1951, when the permanent cables can be laid. In the meantime, the bridge is being raised about 5 ft. and surfaced down to the existing road on the Rotherham side where the manhole shaft is to be raised about 2 ft.

Prior to the closing to traffic of this part of the bridge, five stout poles were erected on the land alongside the bridge, but below its level, to form a temporary route arranged to cross, (a) the entrance to the station goods yard (12 yds.); (b) the canal (17 yds.); (c) a side road (18 yds.); and (d) a field (12 yds.). At each end a ramp was constructed of stout poles and arms, the one on the Sheffield side being as illustrated. As soon as this part of the bridge was closed to traffic,



RAMP CONSTRUCTED ON SHEFFIELD SIDE; DRAWING THROUGH OF 3RD CABLE IN PROGRESS.

lengths of 4 W.M.D. (11 yds. and 14 yds. respectively) were laid from each ramp to its corresponding manhole, a non-standard surface box having been constructed at the foot of each ramp.

Four suspension wires were erected and the interruption cables drawn through pulleys by means of a motor cable winch, the rings being fitted afterwards. The handling of the

heavy cables from the drum up to the ramp and the laying out of cables on the ground at the other end was greatly facilitated by the use of pulleys on stands lent by the Electricity Board. One of these is shown in the centre of the photograph. The length of cable from the bottom of each ramp was measured out and then fed into the duct to the relative manhole so that all jointing was confined to the two manholes. The cables were secured to the ramps by soldering to sheet lead wrapped round arms at six-foot intervals, and boxed in for protection.

The circuits were changed over into interruption cables and the existing cables recovered. The Sheffield-Doncaster cables Nos. 1, 2 and 3 are to be lengthened by unidiameter jointing ready to be drawn into the new ducts. The level of the bridge is now being raised and the old duct has been abandoned. A 12-way duct will be laid in the new bridge and the permanent cables drawn in. As mentioned previously, it is expected that the bridge will be finished by the end of the year; the remainder of the work and the recovery of the poles will then be carried out.

E. A. S.

Midland Region

WEEDON TEST HUT

This land mark on the London-Holyhead Road has lost its original outward appearance but has been given a new lease of life as a U.A.X.13X. Standing at the junction of three main overhead routes between London and the North, and an east to west cross country route, it was erected in 1898 to serve as a test point on overhead circuits between London and Coventry, Birmingham, Hanley, Liverpool, Manchester, Leeds, Preston

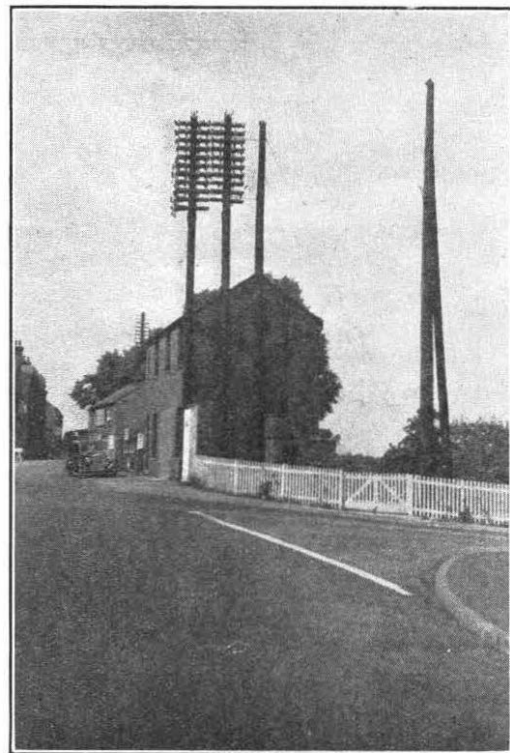

WEEDON TEST HUT.

and Glasgow. The photograph was taken after all the wires and some of the arms had been recovered from the group of 55-ft. stout poles adjacent to the hut. The poles have since been recovered.

The heavy-gauge wires, from 200 lb. to 600 lb., were led in by 14-pair cables to a test frame on the first floor of the brick-built "Test Hut." Two verticals of a later test frame still remain, together with a heavy cast iron "cable connection box" which is a test point on the London-Birmingham No. 1 cable. This cable was laid in 1898, and is the oldest main underground cable in the world.* A recently opened joint on this cable was

* P.O.E.E.J., Vol. 31, p. 147.

in perfect condition and contained two slips of paper signed by the two jointers and two plumbers on the 13th March, 1899.

The linesmen's file of instructions includes Technical Instruction No. 15 of 1896; conversion table from British Association ohms to Standard ohms; and a number of later instructions dated 1897, 1904 and 1912. These will now be supplemented by the duty copies of Engineering Instructions on U.A.X. maintenance, but the Technical Instructions will remind the present-day linemen of the work done in the days when even the value of the ohm was subject to change of policy.

The ground floor of the Test Hut was specially adapted to accommodate the U.A.X. The double doors have been bricked up, the floor levelled with concrete and the walls finished with anti-condensation paint. The windows have been fitted with reinforced glass and the original stove flue has been used for a Hatton ventilator, with two more ventilators fitted in the new brick work.

H. H.

EXCEPTIONAL DAMAGE TO TRUNK POLE

Recently, a laden 30-cwt. truck crashed into a 45-ft. stout pole on the old "Acquired" trunk route south of Coventry. The pole was struck at the 10-ft. mark and was cleanly broken at three points: (a) between the eighth and ninth arms; (b) at a point 4 ft. above ground level where a post box was secured by iron bands; and (c) at a point 2 ft. below ground level where there were signs of decay. The pole was a 1927 "K" type, and was standing in made-up ground on an embankment 12 ft. above normal ground level.

The head of the pole was lifted 11 ft. above the centre of the road, suspended by 34 heavy copper wires and ten 40-lb. wires. Two 7/8 stay wires remained attached to the head of the pole.

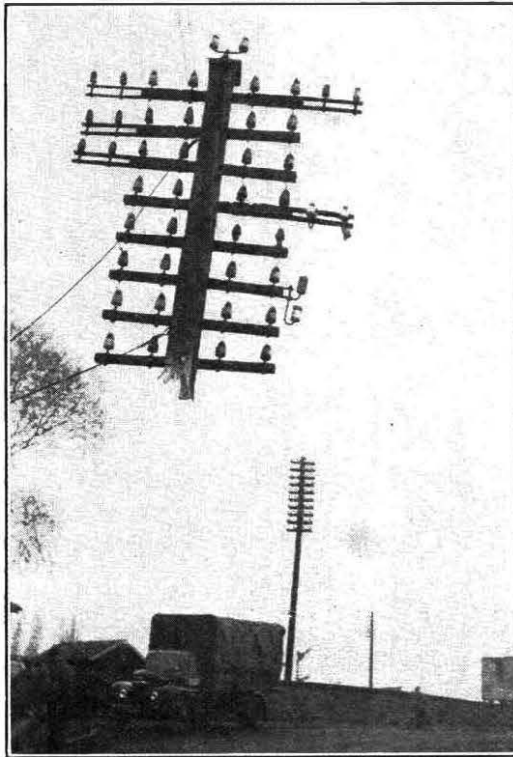

HEAD OF BROKEN POLE SUSPENDED ABOVE ROAD.

A pair of wires from the sixth arm to a pole opposite serve a Police pillar, which remained in service, and was used by the Police patrol to call out the engineering staff.

The accident occurred during a thick mist at night, and the police closed the road to traffic until daylight, when a new pole was erected. The head of the old pole was pulled across and supported on two ladders whilst the wires were transferred one at a time.

The photograph shows the head of the pole suspended over the centre of the road.

H. H.

London Telecommunications Region

BUCKHURST EXCHANGE FESTIVAL OF BRITAIN DEMONSTRATION

A public demonstration of director working has been staged at Buckhurst exchange as a preliminary to visits to the apparatus room. Three separate units were constructed to represent Buckhurst exchange (illustrated in photograph), a distant exchange (Wanstead) and a manual board. Sufficient switching equipment is provided to show the operation and routing of all types of auto calls, including shared service, and

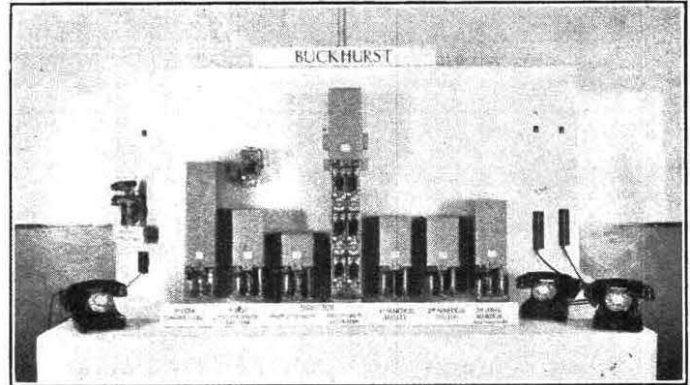

DEMONSTRATION UNIT REPRESENTING BUCKHURST EXCHANGE.

the manual board section demonstrates the "0" level, TOL, TRU and ENG facilities. The demonstration has aroused considerable interest locally, some 800 visitors attending in the first ten weeks.

The units were designed and constructed by the Buckhurst exchange staff, whose courtesy and patience has earned many expressions of appreciation from members of the public.

A. E. H.

EXHIBITION KIOSK

The variety of work required from the L.T.R. Power Section is already well known in the Region, but it is thought that a recent unusual request and our endeavours to meet it may be of interest.

The request came from the Public Relations Department for an Exhibition Kiosk to give overseas telephone and telegraph services at various Exhibitions around the country. The kiosk had to be readily erected, dismantled and transported, to be of first-class appearance and generally in accordance with a small model supplied. The drawings were prepared and the kiosk was constructed entirely in the Power Section within a period of two months from the initial enquiries. The photograph shows it in use at the Business Efficiency Exhibition at Olympia. The kiosk is arranged for fluorescent lighting in the



EXHIBITION KIOSK INSTALLED AT BUSINESS EFFICIENCY EXHIBITION, OLYMPIA.

cubicles and behind the fascia boards, and is finished in polished hardwood and grey with a blue inlaid floor. It can be erected and dismantled without the use of tools and appears to have successfully met the P.R.D.'s requirements in all respects.

R. M. H.

GENERATOR SIGNALLING FROM SELECTOR LEVELS

A recent extension of Toll "A" has provided this country with its first generator signalling circuits trunked from selector levels.

The routes served by this new equipment are those to Canterbury, Portsmouth, Southampton and Winchester. Sufficient relay sets have been provided to serve a total of 276 circuits, and operators having access to Toll "A" can now reach these towns without the assistance of a Toll "A" operator.

C. G. G.

ORSETT U.A.X. 13X

In April, 1951, the first U.A.X. 13X in the L.T.R. was opened for service. This U.A.X., which is situated in rural Essex, replaced a U.A.X.5, and is planned for an ultimate capacity of 400 D.E.L.s.

This building, which is the first of its kind, was designed by the Ministry of Works' architects. The main portion of the building consists of an apparatus room 19 ft. x 31 ft. 6 in., with normal 10 ft. clear height. The flat-roofed part contains a staff room 12 ft. x 12 ft., a W.C. and normal stock room. The apparatus room includes sufficient space for batteries which are of the totally enclosed pattern. The cable trench supports two "C" units and one "D" unit.

In view of the difficulty of procuring suitable flame-proof fibre board for the insulating lining, aluminium-faced plaster board has been installed experimentally.

M. B.

POTTERS BAR EXCHANGE OPENED TO PUBLIC

The North Area contribution to the Festival of Britain was to open Potters Bar 2,000-type non-director exchange for public inspection from 7th to 19th May.

Nearly 1,000 visitors were shown round the building, the peak, 159, being reached on Whit. Saturday when a small queue formed to await opening time. A number of exhibits, some made up locally and others obtained from the Publicity Section, were arranged on the auto floor and in the cable chamber. Included in the latter was a tree of the new London-Leicester composite co-axial cable and a length of 400 lb. copper recovered from the Great North Road, Potters Bar, after being in service 50 years. These items were used to illustrate one of the advances that have been made in long distance communications in the past 50 years. As a result of this the following paragraph appeared in the local press report of the event. "An interesting section of cable in the cable room shows two holes $\frac{1}{2}$ in. in diameter, on which 660 conversations can be carried on at the same time." Whilst this description of coaxial cable would not satisfy the examiners of the City and Guilds Institute, it did arouse the interest of the public, and the "cable room" was a popular feature with all visitors.

W. F. H.

Home Counties Region

ALFRISTON U.A.X. No. 13X

The mobile U.A.X. No. 13 at Alfriston, Sussex, which was brought into use in September, 1948*, was withdrawn from public service on 2nd May, 1951, having been replaced by a permanent installation. The mobile exchange has proved entirely satisfactory.

The permanent building at Alfriston is based on the standard Type B1 design, but has a number of special structural features. It is slightly larger than normal, the extra length being required to cater for ultimate junction requirements. In order to preserve the amenities of this ancient village, and to be in keeping with the surroundings, the exchange, shown in the illustration, is constructed of Sussex flint by local craftsmen who have spent their lives on this type of work. Owing to the flint construction, the walls are not cavity, as normal, so the

inner walls are lined with insulating board. Due to the fall of the land away from the building the cable trench is unusual in depth for this type of exchange, but this feature emphasises the benefits to be gained from having adequate space for cable jointing operations. In this case the jointers were able to work beneath the "C" units, as in a manhole.

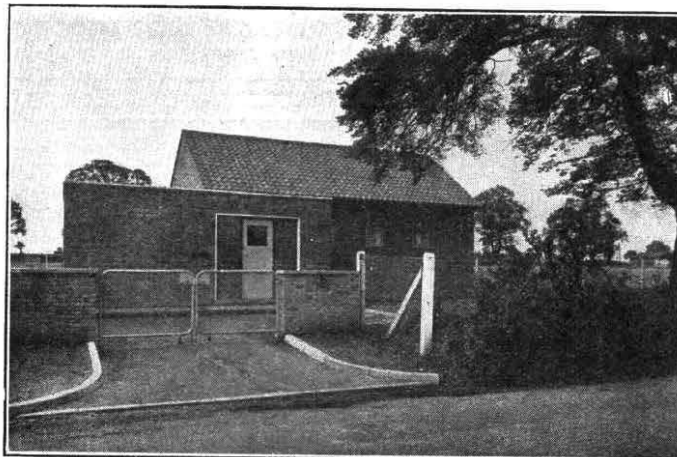

BUILDING FOR ALFRISTON U.A.X. 13X.

The site was obtained by compulsory purchase after High Court proceedings and is considered suitable from the points of view of both the Ministry of Town and Country Planning and the Post Office; moreover the local amenities are not adversely affected.

The new exchange comprises six "A" Units, two "B" Units, two "C" Units and one "D" Unit. F. V. P.

MOLEDRAINING CABLE IN SHINGLE

Some months ago the Ministry of Supply asked the Post Office to provide supervision and technical advice in connection with the laying of cables in a stretch of shingle on the coast in the Colchester Area. The labour, other than that for jointing and testing which was done by Post Office staff, was provided by the Ministry of Supply who also carried out the constructional work for the modification of the appliances used. Although this operation may appear to be of limited interest, it is felt that the experience gained is of sufficient value to place on record.

The prime mover used was a standard model caterpillar tractor, International T.D.14, 60 h.p. The mole plough was of standard type made by Messrs. Ransome, Sims & Jefferies of Ipswich. When first used on the shingle, the 5 in. wide wheels fitted to the plough were found to be of insufficient width to withstand the pull of the mole. By surrounding the periphery of the wheels with 12 in. wide rims of $\frac{1}{8}$ -in. sheet iron, the wheel area then in contact with the shingle was found to be adequate for all purposes. It was then possible to lay cable at any depth from 6 in. to 24 in.



MOLEDRAINING CABLE IN SHINGLE.

* P.O.E.E.J., Vol. 42, p. 113.

It was anticipated that the transport of the drum of cable, which weighed 2 tons 5 cwt. when full, would present some difficulty. This was overcome by the employment of a borrowed ex-R.A.F. crash landing bogey, which was converted into a cable drum trailer by the erection of a steel superstructure to support the drum. The bogey was fitted with 14-in. tracks running on three wheels at each side, and was found to be an ideal vehicle for the fully loaded drum. During the operation it was necessary to traverse both marshland and shingle, which was done satisfactorily.

The cable drawn in was 14-pair P.C.Q.T., with a special alloy sheath, the whole being covered with hessian. Owing to this cable having been in store for some time, it was found that portions of the hessian covering had slightly deteriorated. This led to the only difficulty encountered, in which the hessian covering showed a tendency to strip from the sheath and blocked the guide tube on the mole plough.

The accompanying photograph shows the appliances in use during the operation.

E. J. V. T.

SLIDING A U.A.X. 13

On a recent extension of a U.A.X.13 to a 13X in the Colchester area, it was necessary to move all units (1C, 4A, 5B) en bloc a distance of two feet. This was to accommodate another C unit and a D unit at the side of the existing C unit. The building is a standard B1 type with molar brick inside walls. Owing to inter-unit cabling it was impossible to slacken the cable duct bolts to give a degree of flexibility to each unit.

To slide the units two pieces of 1 in. round iron, $\frac{1}{4}$ in. thick and 16 ft. long, were placed under each row with an additional two pieces 4 ft. long for the larger width of the C unit. To do this the units were lifted singly along each side of the row by the use of "toe" jacks and packing introduced. The "toe" had to bear on the top under-side of the side channels. A length of 1-in. hardwood board across the unit sides prevented the jacks from tilting.

The lift was small, sufficient to insert packing pieces of iron of $\frac{1}{8}$ in. thickness, leaving space for the slide irons. When all units had been raised, the slide irons were placed in position and, using the toe jacks again, the packing removed. To move the two rows of units hydraulic jacks were placed on their sides to bear on the bottom of the vertical angle iron frame, i.e. just above the channel iron, with a thick wood packing piece between the jack head and the unit. The wall behind, being of soft molar or air-cored brick, had a very doubtful strength to take a heavy thrust. However, by the use of stay blocks to distribute the pressure of the jack bases, everything went smoothly. With one man at each jack handle and one making certain that both rows moved at the same speed, the actual movement was completed in half an hour. Stayblocks were used for packing when jacks had been extended to their limits. The two suites of units moved forward easily on the greased iron and in perfect line. This process was repeated until the units were in their final position and the "toe" jacks were used to remove the iron rods. Previously the jointers had lengthened the U.G. cables and no damage was caused by the movement of the units.

J. S.

THANET AUTOMATIC CONVERSION

The Thanet automatic exchange, together with its four satellite exchanges, was brought into service on 31st May, 1951. The official opening ceremony was performed by the Assistant Postmaster-General on 4th June, 1951. The new non-director system serves the towns of Margate, Ramsgate, Broadstairs, Westgate and Birchington. The Thanet area, together with some adjacent U.A.X.s., forms one of the few provincial Group Centres which are entirely composed of automatic exchanges.

The conversion was originally planned to take place in 1940 and building work was put in hand to this end. The four satellite exchange buildings were completed, and the main exchange building was commenced when the outbreak of war caused the work to be deferred. During the war years the telephone requirements of these holiday resorts were considerably reduced, and much of the manual exchange equipment was recovered and transferred to meet the increased demands at other towns. After VE day the telephone requirements in the Isle of Thanet rapidly grew, and the manual exchanges were extended to the limits of the available accommodation in an endeavour to meet the demand, which had

become even greater than pre-war because of the establishment of light industries in the locality. It was therefore decided to proceed with the automatic conversion and, after some difficulties and delays, the construction of the main exchange building was recommenced in 1948.

In the summer of 1948, the Post Office work for the conversion commenced on site with the provision of the necessary new underground duct tracks. It is perhaps worthy of record that this is the first occasion on which the Local Authorities have agreed to the execution of such works during the holiday season. As the new duct tracks were completed the local staff provided additional cables and arranged the diversion of the external plant to the new exchanges, this work being completed by Christmas, 1950. Concurrently a new Canterbury and Margate 542/20 MU cable and a new Margate-Ramsgate 242/20 CJ cable were provided by Siemens Bros.

The new exchange equipment was provided and installed by the General Electric Co. who commenced work on site in August, 1949. The following schedule indicates the capacity of the old and new exchanges.

THANET AUTO AREA					
Exchange	Old		New		
	Type	No. of Subscribers	No. Range	Multiple Capacity	Type
Thanet (Margate)	C.B.10	3,050	20,000-23,999	4,000	Main N.
Westgate	C.B.S.1	709	31,000-32,199	1,200	Satellite
Birchington	Magneto	644	41,000-41,999	1,000	Satellite
Ramsgate	C.B.10	1,869	51,000-53,599	2,600	Satellite
Broadstairs	Magneto	1,528	61,000-62,999	2,000	Satellite

A sleeve control auto-manual board of 50 positions has been provided at the main exchange. Facilities for inter-dialling between Thanet and the London Toll area are given by the use of L.D.D.C. equipment. The equipment at the satellite exchanges includes 1st selectors and discriminators AT 4355 and AT 4356.

The change-over arrangements necessitated the rearrangement and re-routing of a very considerable number of trunk and junction circuits, together with the provision of a complicated switching arrangement for this line network. The strenuous efforts of the Area, Regional and Contractor's staffs were rewarded by a very successful change-over. The new auto system is giving excellent service and many favourable comments have been received from the Thanet subscribers.

CANTERBURY—INTRODUCTION OF MULTI-METERING FACILITIES

In conjunction with a recent major extension of Canterbury non-director auto exchange, multi-metering facilities have been provided enabling the subscribers to have direct dialling access to 20 automatic and 8 manual exchanges. The additional equipment was provided by Ericsson Telephones, Ltd. The associated trunking and circuit rearrangements were carried out by direct labour.

Canterbury is a Group Centre serving a large rural area, and the work involved a change from two- to three-digit dialling-out codes for 25 routes and the provision of 7 new dialling codes. This, in turn, necessitated the rearrangement of multi-metering fee strappings on all junction relay sets at 14 dependent U.A.X.s. After full consideration of several possible methods of effecting the change-over of dialling codes, it was decided to adopt the following procedure as it involved a minimum of engineering costs without causing serious inconvenience to the subscribers:—

- All subscribers (main exchange and dependent U.A.X.s.) were advised that their inter-dialling facilities were temporarily withdrawn while changes were effected, and they must pass inter-exchange calls via the manual board by dialling "0."
- Jumper changes were completed at Canterbury exchange to connect the junction routes to their new levels. All jumpers were run before stage (a). Of the many involved stages, one alone comprised the shifting of six fully-equipped R/S racks with the attendant rearrangement of shelves and jumpering.

- (c) While (b) was in progress the necessary changes were effected to the strappings on the U.A.X. multi-metering relay sets. This work was tested by functional tests carried out jointly by engineering and traffic staffs.
- (d) As soon as (b) was completed, the Canterbury subscribers were advised that new facilities were available and they were supplied with new dial code lists to be gummed into their directories. As individual U.A.X.s were proved to be satisfactory by tests in (c), the subscribers on the exchange were advised and supplied with new dial code lists.

The operation called for close co-ordination between engineering and traffic staffs to ensure that the appropriate letters were despatched at the correct time, and this was achieved without difficulty. The change-over was effected smoothly and the complete operation was carried out in about four weeks.

Scotland

UNORTHODOX METHODS OF LINE CONSTRUCTION

On the 19th March, the North East coast of Scotland experienced another of the severe storms which have been a too frequent feature of the past winter. The storm, which was accompanied by high winds and snow, caused widespread damage of the usual nature, but, in addition, severed the one-pair submarine cable which connects the rock lighthouse at Rattray Head to the shore, disrupting telephone communication.

This lighthouse, sited at an isolated and dangerous spot on the North East point of the Buchan Coast, contributes largely to the safety of shipping in the area and failure of communication with the shore is very serious.

The cable is 560 yds. long and for the major part of its length is buried in the sand and partially anchored by boulders on a rough causeway (see photograph), but for the last 300 odd yards it lies in the deep water which surrounds the rock. Normally the causeway is under water, but at low tide it becomes partially exposed; only occasionally is the low tide of



CAUSEWAY TO RATTRAY HEAD LIGHTHOUSE.

any duration. Tests from the terminal pole at the shore end of the cable proved the conductors to be full earth and a hasty inspection during a very brief low tide on the 20th showed the cable to be severed at a point near the base of the lighthouse. Permanent repair at this time was out of the question because of the time factor and it was decided to give temporary service by running overhead wires from the terminal pole to the lighthouse, a distance of over 500 yards.

Fortunately, there was to be a low tide of two hours' duration during the late afternoon of the 21st March, so the Maintenance Assistant Engineer arranged for two of the local linemen and an Advice Note gang stationed in the locality to be on the spot with the necessary line stores at the appropriate time. It was hoped that by then the weather would have improved, but instead, the men were met by a blinding snow-storm. However, since there was not to be another low tide of reasonable duration for several weeks it was decided to carry on with the repair.

As soon as the tide had receded sufficiently, two men, each with the end of a coil of 70 lb. c.c. wire, set off to pick their way over the slippery boulders and rocks of the rough causeway to the lighthouse, whilst two other men on shore paid off the wire. On reaching the lighthouse, one man made his way up to the balcony and dropped a rope to the base where each wire in turn was fastened to the rope and pulled up to the balcony level. The wires were then tensioned by ratchet and tongs and terminated on Insulators, Stay No. 1, fastened 12 ft. apart to the railings around the balcony. Drop wiring was then used to provide a lead-in. Whilst this operation was in progress, the remainder of the staff had fixed an arm and stay to the terminal pole and terminated the wires. The work was completed well within the available time and the span of wire is still giving service despite further stormy weather.

Further examination of the cable at a later date showed that it would be necessary to renew about 100 yds., so this is to be done by Area staff when the new cable is to hand. Once again renewal of the length, splicing and jointing will all have to be completed in the duration of a low tide which at the maximum is about five hours.

The lighthouse itself was erected on the Ron Rock in May, 1895, and its height to the top of the lantern is 113 ft. The lamp is a pressure oil type and its beam can be seen for a distance of 15½ miles. During the last war the light was "shot up" by enemy aircraft and both the lantern and reflector were damaged—the reflector still bears the scars.

S. T. M.

BRITISH ASSOCIATION MEETING IN EDINBURGH

The meeting of the British Association in Edinburgh was especially notable for the transmission of the proceedings at the McEwan Hall, including the Presidential Address, by television at a frequency of 6,800 Mc/s to the Usher Hall, where it was seen on a full-sized cinema screen by an audience of 3,000. Members of the staff were invited to see the equipment during its initial tests, and also to attend the proceedings which, as will be known from the Press, were a complete success. On Wednesday, 10th August, members of the British Association were invited to visit the joint trunk exchange, George Street director exchange, the repeater station and the Fountainbridge telephone exchange building now under construction, where they were entertained to tea. Twelve parties in all toured the buildings under the care of individual conductors after a welcome from the Telephone Manager.

At various points demonstrations were staged. A special demonstration set was designed by the local staff to show the progress of either director or non-director calls, and manual board terminations including 999 service. Despite the need for keeping to a strict time table, our guests seemed to appreciate their visit as much as we did. In fact, after one demonstration, a youthful member of the party stayed behind to enquire how "back dialling" was performed. We were not able to enlighten him, but he should go far. (We do not know which branch of science he intends to pursue but have certain suspicions).

J. W. B.

Junior Section Notes

Aberdeen Centre

The 1950/51 Session was a very successful one, the programme being:—

October.—Variety Fare No. 3—Various Junior Members.
November.—Telegraphs (Manual and Auto Switching).
Mr. R. Show.

December.—Quiz: Senior Section v. Junior Section.

1951:

January.—Design of P.O. Buildings, Mr. H. J. Revell, B.Sc.

February.—Hydro-Electric Board, Mr. A. W. Perkins, B.Sc., A.M.I.E.E.

March.—A.G.M. Plus—Various Junior members.

The following were elected Office Bearers for 1951/52:—
President, Mr. H. J. Revell, B.Sc., Area Engineer; *Chairman*, Mr. J. D. Thomson; *Vice-Chairman*, Mr. D. S. C. Buchan; *Secretary and Treasurer*, Mr. J. H. Lawrence; *Librarians*, Mr. F. J. S. Marshall and Mr. A. S. Mutch; *Auditors*, Mr. D. D. Milne and Mr. R. W. Lord. *Committee*:—Mr. J. MacLachlan, Mr. G. C. McKee, Mr. F. L. Crabbe, Mr. E. D. Petrie, Mr. N. K. Sutherland, Mr. J. Yale.

At the time of writing, the following lectures are in the process of organisation for 1951/52:—

The Abadan Oil Refinery—Mr. W. H. Buchan.

The Aberdeen City Police Radio System—Mr. E. G. Ingram.

The Postal Side—Mr. J. H. Waterston.

Road Traffic Problems—Ch.-Insp. A. J. Smith,

and we are hoping for two more papers to complete the programme.

There is plenty of seating accommodation at the Aberdeen Centre and the committee are looking forward to record membership and attendances during the 1951/52 Session.

J. H. L.

Cambridge Centre

The Annual General Meeting of the Centre was held in April, 1951, and the officers for the coming year were elected as follows:—*Chairman*, Mr. L. A. Salmon; *Vice-Chairman*, Mr. H. W. Haworth; *Secretary*, Mr. J. P. Wearn; *Treasurer*, Mr. B. S. Cranfield. *Committee*:—Mr. H. P. Brooks, Mr. S. J. Davis, Mr. R. M. Jones. *Auditors*:—Messrs. L. W. Pooley and N. Radford.

The programme for the first part of the Session is as follows:—

October.—Visit to the United Telephone Cable Works at Dagenham, Essex.

October.—"Open Night", Cambridge Automatic Exchange and Repeater Station.

November.—Visit to Sugar Beet Factory at Ely, Cambs.

December.—Lecture: "Photography" Part 2, by Mr. S. J. Davis.

The membership would like to wish our Liaison Officer, Col. T. C. Loveday, every success in his new appointment in London.

J. P. W.

Bishops Stortford Centre

On 4th April a lecture on "Radio Valves" was given by Mr. J. S. Rogers. The next month a talk on "Photography," by Mr. G. Wyer, was made very informative with the help of practical demonstrations. The 1950/51 Session closed with a film show given by the Central Office of Information, followed by the Annual General Meeting. The Chairman, Vice-Chairman and Secretary were re-elected, the Committee also being re-elected en bloc.

A Committee Meeting was held on 30th May at which the following programme for the 1951/52 Session was arranged:—

18th September.—A Film Show by the C.O.I. followed by a lecture given by Mr. G. F. Dann on "Air Navigation."

17th October.—Demonstration on the "Joining and Testing of Coaxial Cable," by Messrs. A. Stanley and R.

Fuller, followed by a talk on "Various Methods of Fault Localisation on Underground Cables," by Mr. G. Wyer.

14th November.—A lecture on "Railway Signalling," by Mr. F. Frecknall.

5th December.—A film show by the C.O.I.

6th January.—A paper on "Simple Radio Circuits," by Mr. J. Poole, with demonstration of fault finding and the alignment of tuned circuits.

February.—It is hoped to arrange visits to the Battersea Power Station and the Ford Motor Works at Dagenham.

12th March.—A paper on "Trunk Mechanisation," by Mr. A. J. Thompson.

9th April.—A lecture by Mr. R. Eves on "The Survey and Provision of Local Lines."

Our membership figure, now 41, shows an encouraging upward trend.

J. S. R.

London Centre

The 1951 Annual General Meeting of the London Centre was honoured by the presence of Mr. W. S. Procter, Chief Regional Engineer. During the meeting Mr. Procter presented

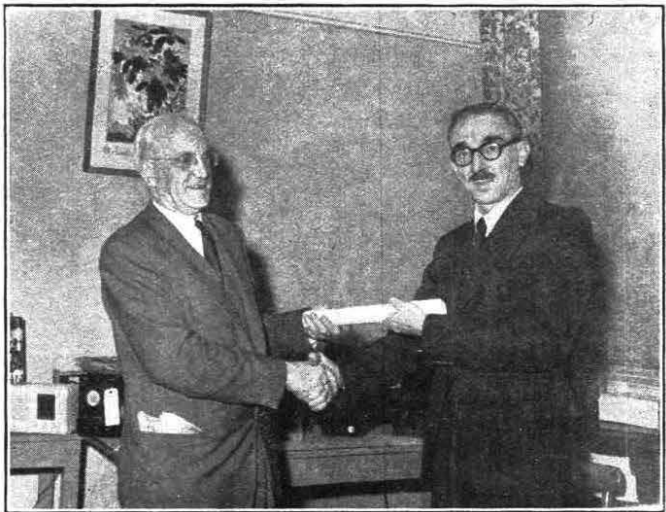

an Institution Certificate to Mr. H. Baines (Technical Officer) for his paper entitled "An introduction to Managerial Co-ordination," and later inspected Radio and Television equipment made by members of the London Centre Radio Group in their off-duty hours.

M. J. G.

Guildford Centre

One of the most interesting visits so far made by members of the Guildford Centre was to the newsprint and fibre board mill of Messrs. Bowaters, Lloyd & Co., Sittingbourne, Kent, on 25th July. It was a matter for some regret that more members were unable to come, for it is doubtful whether another visit can be arranged.

Upon arrival at the Kemsley Mill the party was separated into small groups and conducted by members of the Electrical Drawing Office staff through all departments, where trees are converted into newsprint and fibre board via grinders, pulpers, cleansers and the huge paper-making machines—one of which was said to be the largest in the world—where the liquid pulp was converted into a web of paper 240 in. wide at the rate of 1,100 ft. per minute.

The power plant was on an equally immense scale, some of the machines requiring motors of 2,700 h.p. at 6.6 kV. The power being consumed at the time of the visit was 3.2 megawatts and we were told the plant was only two-thirds in operation.

Future visits are as follows:—

17th October.—Cigarette & Tobacco Production, Carreras, Ltd., Hampstead, London.

17th October.—Food Production: J. Lyons, Ltd., Cadby Hall, London.

(continued on page 145).

Retirements

Name	Region	Date	Name	Region	Date
<i>Snr. Exec. Engr.</i>			<i>Asst. Engr.—continued.</i>		
Lewis, S. G.	E.-in-C.O.	16.7.51	Finch, T. H.	W.B.C. Reg.	2.1.51
			Chapman, C. J. W.	W.B.C. Reg.	1.2.51
			Argile, J. H.	S.W. Reg.	31.3.51
<i>Exec. Engr.</i>			<i>Inspector.</i>		
Spiers, J. C.	Mid. Reg.	8.8.51	Davies, E. S.	S.W. Reg.	28.2.51
Arran, I.L.	L.T. Reg.	30.6.51	Blatchford, R. A.	S.W. Reg.	31.1.51
			Pool, I. C.	L.P. Reg.	26.2.51
<i>Asst. Engr.</i>				Scot.	8.6.51
Wood, J.	N.E. Reg.	12.6.51	Michie, P.	Scot.	8.6.51
Stone, C. H.	L.T. Reg.	10.7.51	De Carle, H. V.	L.T. Reg.	31.5.51
Jones, V. H.	E.-in-C.O.	31.7.51	Edwards, A.	L.T. Reg.	17.7.51
Burke, R.	E.-in-C.O.	31.7.51	Harman, C.	L.P. Reg.	14.2.51
			Faulkner, J. H.	N.W. Reg.	27.8.51

Deaths

Name	Region	Date	Name	Region	Date
<i>Exec. Engr.</i>			<i>Asst. Engr.—continued.</i>		
Wallis, I. H.	H.C. Reg.	14.7.51	Stanesby, R. G. C.	L.T. Reg.	26.7.51
<i>Asst. Engr.</i>			<i>Inspector</i>		
Kendall, H.	Mid. Reg.	7.6.51	Mill, A. E.	Scot.	13.8.51
Ivory, J.	E.-in-C.O.	10.7.51			

◆

CLERICAL GRADES

Promotions

Name	Region	Date	Name	Region	Date
<i>H.E.O. to S.E.O.</i>			<i>E.O. to H.E.O.</i>		
Ford, A. W.	E.-in-C.O.	1.6.51	Mills, S.	E.-in-C.O.	18.6.51

Transfers

Name	Region	Date	Name	Region	Date
<i>E.O.</i>			<i>E.O.—continued.</i>		
Bevans, H. G.	E.-in-C.O. to Min. of Labour	20.8.51	Johnson, D.	E.-in-C.O. to N.W. Reg.	27.8.51

◆

DRAUGHTSMEN

Promotion

Name	Region	Date
<i>Snr. D'man to Chief D'man.</i>		
Ivory, B.	N.W. Reg. to E.-in-C.O.	1.7.51

Resignation

Name	Region	Date
<i>D'man. Cl. II.</i>		
Ayre, J. H. W.	E.-in-C.O.	22.6.51

Retirement

Name	Region	Date
<i>L/D'man.</i>		
Flatt, H. H.	E.-in-C.O. (Health grounds)	6.8.51

JUNIOR SECTION NOTES (continued from page 142).

14th November.—Sugar Refining: Tate & Lyle, Ltd., Silvertown, London.

14th November.—Margarine Production: Van Den Burghs & Jurgens, Purfleet.

Visits for January, February and March, 1952, and the lectures for the Winter Session are in course of preparation and will be announced shortly.

Darlington Centre

The Annual General Meeting was held on 22nd May, 1951. The Secretary reported the completion of a most successful session with a membership of 74, and an average attendance of 28 members at the meetings. The high standard of talks had been maintained. Mr. Midcalf, Treasurer and Librarian made a good report.

Officers for the 1951/52 Session are as follows:—*Chairman*, W. Gosling; *Vice-Chairman*, N. V. Allinson; *Secretary*, C. N. Hutchinson; *Treasurer and Librarian*, B. Midcalf. *Committee*:—R. W. Cowen, P. Dodd, G. A. Garry, E. O. M. Grimshaw, T. L. M. Hebron, F. Moses, R. Moore, H. G. Midcalf, E. Pinkney, A. Snowden. *Auditors*:—D. F. Dodds and A. G. Hyatt.

On 1st July, 1951, several Centre members joined a Middlesbrough party on a visit to a Radar station.

Our Centre extends greetings to the new President—Colonel C. E. Calverley, O.B.E., B.Sc., M.I.E.E.; we had the pleasure of meeting two of his predecessors in Messrs. D. Smith and H. R. Harbottle.

Now for the spade work for the Session 1951/52!

C. N. H.

Middlesbrough Centre

The Annual General Meeting was held in the Canteen, Head Post Office, Middlesbrough, on 10th May, 1951.

The following officers were elected for the forthcoming session:—*Chairman*, D. Paterson; *Vice-Chairman*, W. J. Costello; *Secretary*, J. Brown; *Treasurer and Vice-Sec.*, R. R. Johnson. *Committee*:—A. Bunnis, H. Carr, P. Garrick, J. Mansfield, E. E. Sparkes, D. L. Taman, W. Torbet.

The programme for the winter session is now being arranged and it is hoped that this will include papers by our own members.

BOARD OF EDITORS

H. FAULKNER, C.M.G., B.Sc., M.I.E.E., Chairman.
F. E. NANCARROW, O.B.E., A.R.C.Sc., M.I.E.E.
W. WEST, B.A., M.I.E.E.
Capt. C. F. BOOTH, O.B.E., M.I.E.E.
L. F. SCANTLEBURY, Whit.Sch., A.C.G.I., D.I.C., A.M.I.E.E.
D. A. BARRON, M.Sc., A.M.I.E.E.
E. DAVIS, A.M.I.E.E.
L. CHANT.
G. E. STYLES, A.M.I.E.E., Managing Editor.
W. A. HUMPHRIES, A.M.I.E.E.
J. P. HARDING, B.Sc.(ENG.)
A.M.Inst.C.E., A.M.I.E.E. } Assistant Editors.
A. J. HUTCHISON, Secretary-Treasurer.

Copyright

The entire contents of this JOURNAL are covered by general copyright, and special permission is necessary for reprinting long extracts, but Editors are welcome to use not more than one-third of any article, provided credit is given at the beginning or end thus: "From the *Post Office Electrical Engineers' Journal*."

The Board of Editors is not responsible for the statements made or the opinions expressed in any of the articles in this JOURNAL, unless such statement is made specifically by the Board.

Communications

All communications should be addressed to the Managing Editor, *P.O.E.E. Journal*, Engineer-in-Chief's Office, Alder House, Aldersgate Street, London, E.C.1. Telephone: HEAdquarters 1234. Remittances should be made payable to "*The P.O.E.E. Journal*"

Following Mr. R. R. Johnson's written paper entitled "Radar," read at Middlesbrough and Darlington Centres during the last winter session and later submitted for the Regional Competition, a visit was arranged by Mr. Johnson to a nearby "Radar" station. The 20 Middlesbrough members and 10 Darlington members who attended voted the visit a great success.

At the moment our recruiting drive for members is in progress. Attendance of members at meetings has been most encouraging, and it is hoped that the same support will be given during the forthcoming session.

J. B.

Tunbridge Wells Centre

The Annual General Meeting was held on 25th April, 1951, after a successful 1950/51 Session. The following officers were elected:—*Chairman*, A. E. Chapman; *Secretary*, E. L. English; *Treasurer*, G. Kingswood. *Committee*:—F. W. Archer, J. English, G. Harrison, A. G. Shoebridge, J. Whyte.

The following programme has been arranged for the 1951/52 Session:—

September.—Film Show to be held at Sevenoaks.

October.—Visit to "Siemens."

November.—Paper: "Blasting," by Mr. L. W. Barratt.

December.—Paper: "E/I and Power," by Mr. R. L. Hurst.

January.—Paper: "Letterpress Printing," by Mr. P. L. Triscott.

February.—Paper: "Trunking and Grading," by Mr. S. Buckland.

March.—Visit: Ford Motor Works at Dagenham.

April.—Visit: Kew Gardens and Variety Show.

May.—Film Show and Annual General Meeting.

At a General Meeting held on 5th June, 1951, it was agreed to set up a Radio Section, and the following were elected:—*Secretary*, J. A. Sparrowe; *Treasurer*, J. Whyte; *Committee*, H. W. Avis, R. S. Kemp. The Radio Section hopes to run a series of lectures with the co-operation of a number of Senior members, and a suitable workshop is being prepared.

We feel that we can now say that we are out of the "rut" and are making steady progress, due to the co-operation of a number of Senior members and to the fact that every committee member has done his bit toward building a progressive Junior Centre.

E. L. E.

and should be crossed "& Co."

Binding Cases

Cases for binding are available, and may be obtained from the Local Agents for 2s. Subscribers can have their copies of volumes bound, at a cost of 7s. 6d., by sending the complete set of parts to the Local Agents or to the *P.O.E.E. Journal*, Engineer-in-Chief's Office, Alder House, Aldersgate Street, London, E.C.1. Orders for binding for Vols. 1-19 should indicate whether the original binding case with black lettering, or the later pattern with gold, is required. Cases with gold lettering are the only type stocked from Vol. 20 onwards.

Back Numbers

The price of the JOURNAL, which is published quarterly, is 2s. 6d. (2s. 9d. post free) per copy, or 11s. per annum, post free. Back numbers can be supplied, subject to availability of stocks, at 2s. 6d. each (2s. 9d. post free). Orders for back numbers may be sent to the *P.O.E.E. Journal*, Engineer-in-Chief's Office, Alder House, Aldersgate Street, London, E.C.1, or to the Publishers.

Employees of the British Post Office can obtain the *Journal* through Local Agents at the reduced price of 1s. 6d. per copy.

Advertisements

All communications relating to space reservations should be addressed to the Advertisement Editor, *P.O.E.E. Journal*, Alder House, Aldersgate Street, London, E.C.1. Communications regarding advertisement copy, proofs, etc., should be addressed to the Publishers, Messrs. Birch & Whittington (Prop. Dorling & Co. [Epsom], Ltd.), 49 Upper High Street, Epsom, Surrey.

REMOTE POSITION INDICATION SERVO CONTROL

MAGSLIPS
SIZES: 1½", 2" and 3"
VOLTAGES:
 50V to 150V
 according to type
FREQUENCIES:
 50c/s to 1100c/s
 according to type

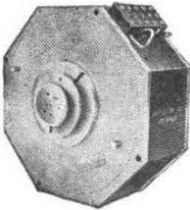
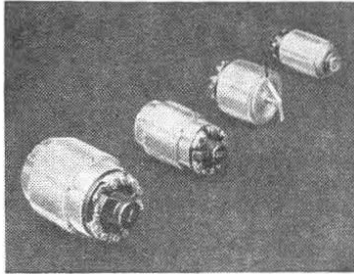

**INDUCTIVE POTENTIOMETER
(IPOT)**

DIMENSIONS: 6½" x 6½" x 3½"

SUPPLY: 50V 50c/s

COMPUTATION POST THIS COUPON FOR DESCRIPTIVE LITERATURE

MUIRHEAD & CO., LTD.
 BECKENHAM · KENT · ENGLAND

Please send me Bulletins B-580 and B-604 fully describing the Magslips and Ipots advertised in the "Post Office Electrical Engineers' Journal"

NAME _____

ADDRESS _____

MUIRHEAD & Co., LTD.
 PRECISION ELECTRICAL INSTRUMENT MAKERS
 BECKENHAM · KENT · ENGLAND
 Phone: BECKenham 0041 Telegrams & Cables: MUIRHEADS ELMERS-END

PRECISION
MUIRHEAD
 ELECTRICAL INSTRUMENTS

284

**ELECTRICAL MEASURING
 INSTRUMENTS
 OF THE HIGHER GRADES**

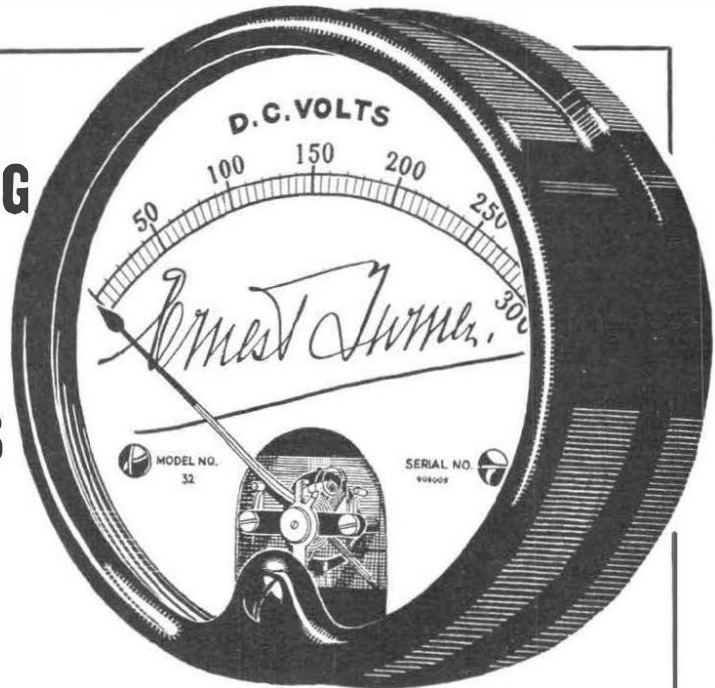

ERNEST TURNER ELECTRICAL INSTRUMENTS LTD.
 CHILTERN WORKS, TOTTERIDGE AVENUE, HIGH WYCOMBE, BUCKS.

Telephone: High Wycombe 1301/2

Telegrams: Gorgeous, High Wycombe



QUALITY

ACCURACY

RELIABILITY

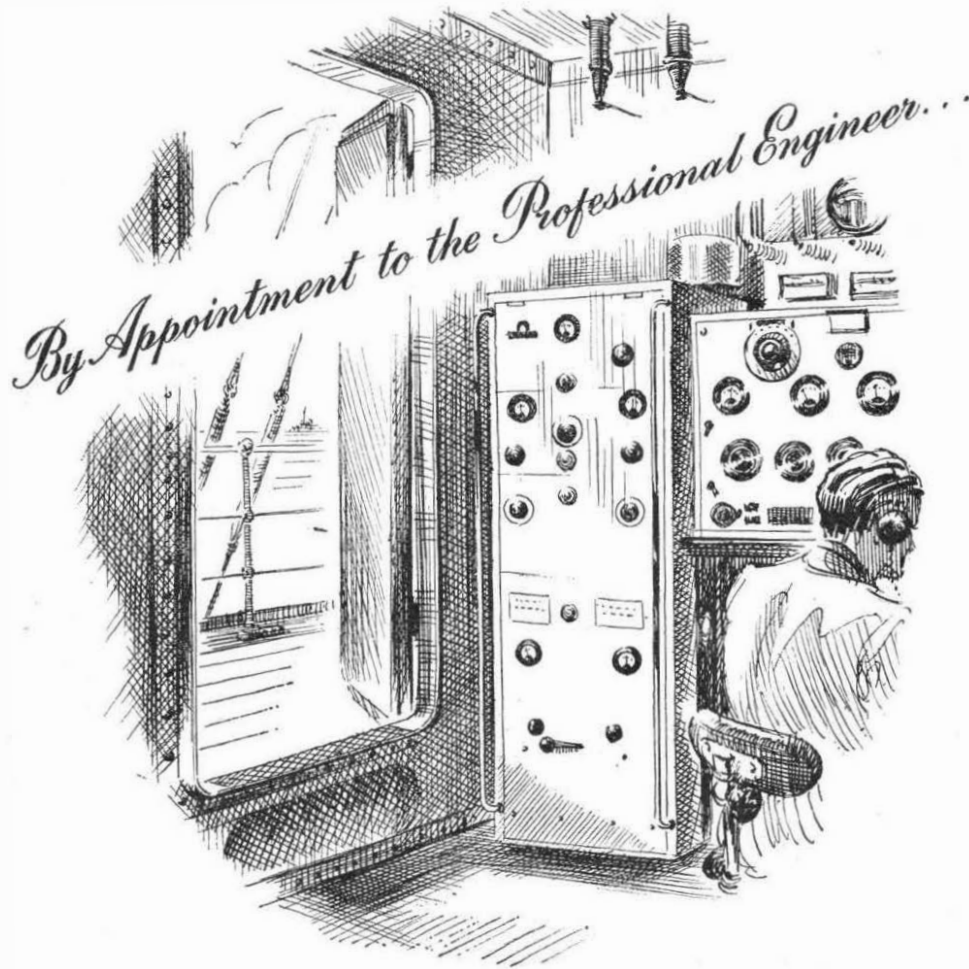

ATTENUATORS · FADERS · SWITCHES · WIREWOUND POTENTIOMETERS · PLUGS
AND SOCKETS · WIREWOUND RESISTORS · HIGH STABILITY CARBON RESISTORS
KNOBS DIALS AND POINTERS · TERMINALS

PAINTON

Northampton England

7-Range CLIP-ON AMMETER Type L

This model is specially designed for use with porcelain clad fuses and heavy duty conductors up to 4" dia. Fully insulated core.

PLEASE WRITE FOR
LIST IN17L.

7 RANGES

0 — 10
0 — 25
0 — 50
0 — 100
0 — 250
0 — 500
0 — 1000
Amperes A.C.



F185



FERRANTI

FERRANTI LTD. HOLLINWOOD LANCS.
LONDON OFFICE: KERN HOUSE, KINGSWAY, W. C. 2.

AUTOMATIC VOLTAGE REGULATORS by B.P.T

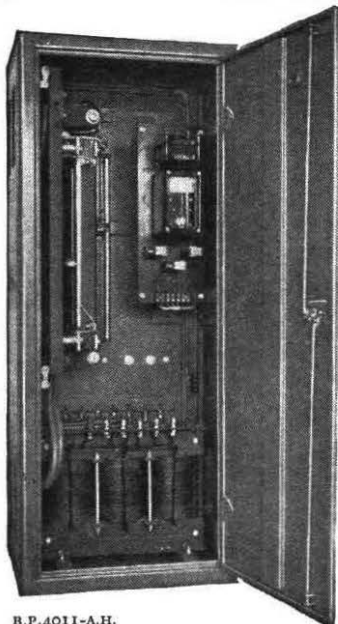

B.P.4011-A.H.

Maintaining a constant voltage unaffected by variation in the supply voltage, frequency, load and load power factor is a problem which can be solved by the aid of our standard range of Automatic Voltage Regulators. For single phase operation there are 11 models from 12½ to 240 amps, for three-phase there are 13 models from 7½ to 150 amps.

Three typical models are illustrated from our standard range of wall or floor mounting types.

- TOP** 3-phase, air cooled, wall mounting model. Input 440V ± 10%, output 440V ± 1%. 7½ amps.
- LEFT** 3-phase, air cooled, floor mounting (cubicle) model. Input 440V ± 10%, output 440V ± 1%. 40 amps.
- RIGHT** Single-phase, air cooled, wall mounting model. Input 250V ± 15%, output 250V ± 1%. 25 amps.

Please write for further information and literature. BP401/9

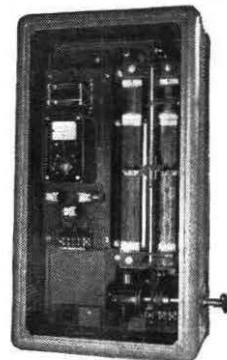
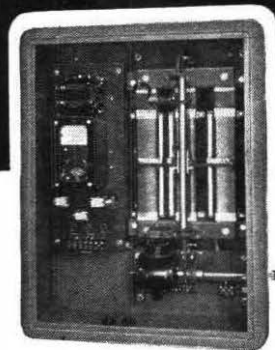

BRITISH POWER TRANSFORMER CO. LTD.

Phone: HOWard 1492 QUEENSWAY, PONDERSE END, MIDDLESEX Grams: "Vitrohm Enfield"

EVERSHED

**SPECIAL DUTY
F.H.P. MOTORS**

**TYPICAL
A.C. MOTORS**

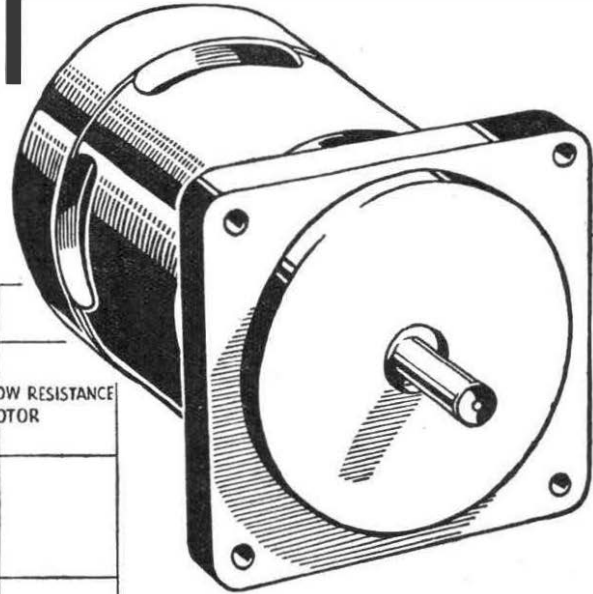

CHARACTERISTIC CURVES FOR
ASYNCHRONOUS MOTORS

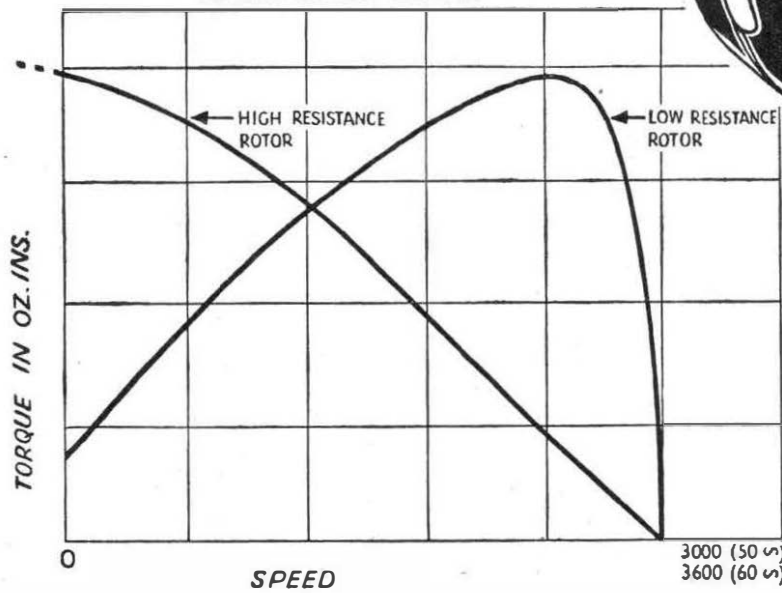

1) The motors may be supplied wound for 60 C.P.S. and other voltages.

2) The asynchronous motors can be supplied with high resistance rotors giving high starting torques.

Frame Size and Symbol	Type	Voltage	Phase	Frequency C.P.S.	No Load Speed r.p.m.	Torque	
						Starting oz. ins.	Running oz. ins.
FC1/O	Asynchronous	230	1	50	2900	2.5	2
FC10/O	Synchronous	230	1	50	3000	0.75	0.75
FE16/C	Synchronous	230	1	50	3000	6	6
FE17/A	Asynchronous	50	3	50	3000	30	9
FE18/C	Asynchronous	230	1	50	2950	11.5	10

*Send for the
Evershed Small Motors'
Data Book X22*

EVERSHED AND VIGNOLES LIMITED

ACTON LANE WORKS · CHISWICK · LONDON · W.4

Telephone: Chiswick 3670

Telegrams: Megger, Chisk, London

Cables: Megger, London

Ericsson

TRANSMISSION EQUIPMENT

For use on open wire lines, cables and radio circuits which may form part of a trunk network or provide point to point working.

The more important products include—

P.O. Amplifier No. 32 for 4-wire repeatered circuits.

P.O. Amplifier No. 35 for music circuits.

Single and 3-channel Carrier System for Open Wires.

Radio—Telephone terminating equipment.

Single Side Band Transmitter Drive Equipment.

Multi Channel V.H.F. Radio Links.

The performance of the equipment is to C.C.I.F. or customer's specification and carries the same quality and finish as the manual and automatic telephone for which the Company is so well known.

***Performance to C.C.I.F. or
customer's specification***

ERICSSON TELEPHONES LTD.

★ This illustration shows a typical 3-Channel Carrier Terminal.

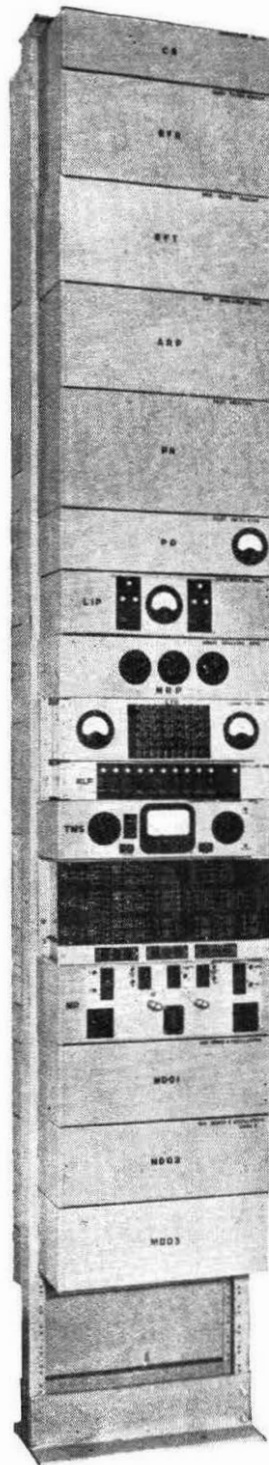

22 LINCOLN'S INN FIELDS · LONDON · W.C.2 · Telephone: HOLborn 6936 · Works: BEESTON · NOTTS

E.4

Cathode ray tube by courtesy of Edison Ltd.

for the best focus on **ECLIPSE**

for **PERMANENT MAGNETS** for television radio and telecommunications

specify **Eclipse**

EM16

JAMES NEILL & CO. (Sheffield) Ltd., SHEFFIELD

VALUABLE FREE BOOK

Tells You How to Pass Your C. & G. or Promotion Exam. at First Attempt!

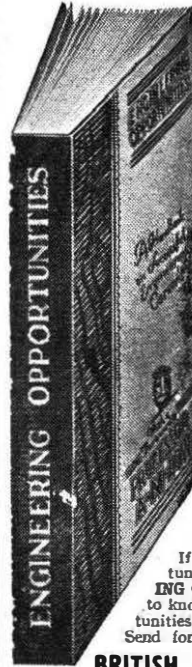

All Post Office Engineering personnel who are anxious to obtain early promotion should at once send for a copy of our handbook "ENGINEERING OPPORTUNITIES," which, among other intensely interesting matter, describes our unique methods of preparation for **TECHNICAL APPOINTMENTS IN THE POST OFFICE** (Assistant Engineer—New Style and Assistant Traffic Superintendent), **CITY AND GUILDS EXAMINATIONS** in Principles of Telecommunications (1-5), Radio (1-4), Telephone Exchange Systems (1-3), Telegraphy (1 and 2), Line Transmission (1 and 2), Lines Plant Practice (1 and 2), Mathematics for Telecommunications (1-5), Electrical Engineering Practice (Prelim, Inter, and Final), and outlines a wide range of non-examination courses in all branches of Electrical, Mechanical, Civil, Automobile, Aeronautical and Radio Engineering.

Assistant Engineer and Assistant Traffic Superintendent. Open competitions now resumed. Age extensions for established Civil Servants. Ask us for full details

We definitely guarantee "NO PASS—NO FEE"

If you intend to make the most of to-day's opportunities, you cannot afford to miss reading "ENGINEERING OPPORTUNITIES." It tells you everything you want to know to secure advancement, and describes many opportunities you may now be missing through lack of information. Send for your copy to-day—FREE and without obligation.

BRITISH INSTITUTE OF ENGINEERING TECHNOLOGY
369 SHAKESPEARE HOUSE,
17-19 STRATFORD PLACE, LONDON, W.1

BIET

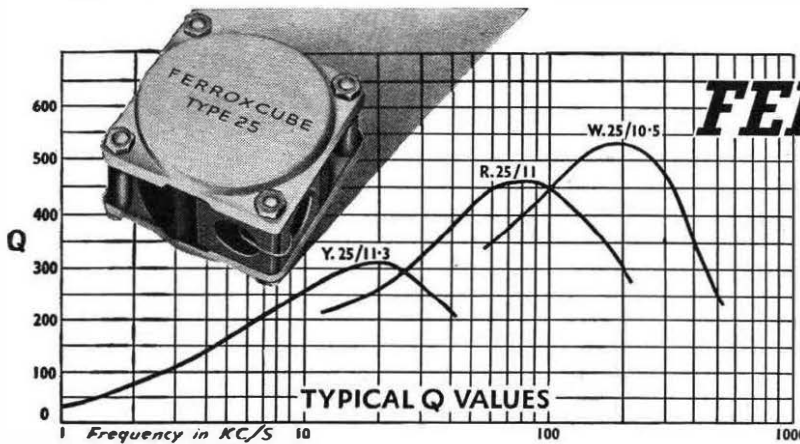

FERROXCUBE

FERROMAGNETIC FERRITE

For Line Communications :

IN THE design of Mullard pot core assemblies type 25 (36) full advantage is taken of the characteristics of Ferroxcube to produce inductances of remarkably high "Q" factors, which, combined with ease of winding, make these cores very suitable for use in filter networks and wherever high quality inductances are required.

Fine adjustment of inductance is obtained by control of the air gap rather than by variation of the turns.

The good screening properties of the Ferroxcube combined with the convenient shape of the assembly, which allows stacking or individual mounting, are features which distinguish these Mullard cores.

- OUTSTANDING FEATURES**
- ★ Low hysteresis coefficient
 - ★ High values of inductance
 - ★ Low self capacitance
 - ★ Controllable air gap facilitating inductance adjustment
 - ★ Self screening
 - ★ Controlled temperature coefficient
 - ★ Operation over a wide frequency range
 - ★ Ease of winding and tapping
 - ★ Easily mounted

PLEASE WRITE FOR FULL DETAILS



Mullard FERROXCUBE

FERROMAGNETIC FERRITE

MULLARD LIMITED · CENTURY HOUSE · SHAFTESBURY AVENUE · LONDON · W.C.2

(MP372)

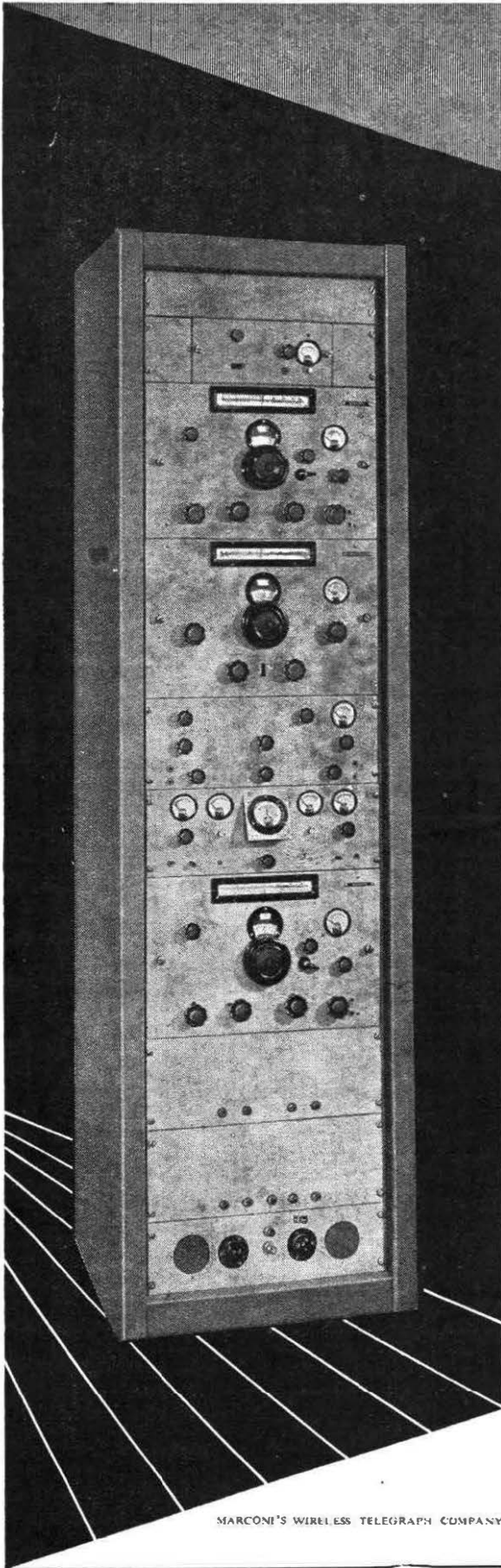

DOUBLE DIVERSITY TELEPHONY RECEIVER

(CRD. 150/22A)

- ▶ Suitable for D.S.B. telephony.
- ▶ Frequency range: 1.5 - 30 Mc/s.
- ▶ Receives: Frequency Shift or On/Off telegraphy or telephony transmissions.
- ▶ Outputs: Telegraphy: Double current or keyed tone.
Telephony: 100 mW into 600 ohms.
- ▶ Supplies: 100 or 200-250 volts, 50 c/s mains, 600 watts consumption.

MARCONI COMMUNICATION SYSTEMS

**SURVEYED · PLANNED · INSTALLED
MAINTAINED**

Components made from DELARON LAMINATED PLASTIC possess insulation properties which remain constant within very close limits. Delaron is tough and durable, easy to machine and punch and the range includes grades which conform to all Industrial, British Standard and Ministry Specifications. Delaron is economical too and is supplied in the widest range of board sizes up to 9' x 4'. Our Technical Service Department will be glad to talk over your problems, or if you will send full details, we will let you have samples by return.

We are indebted to our friends in the Radio and Electric Industry for permission to reproduce these components.

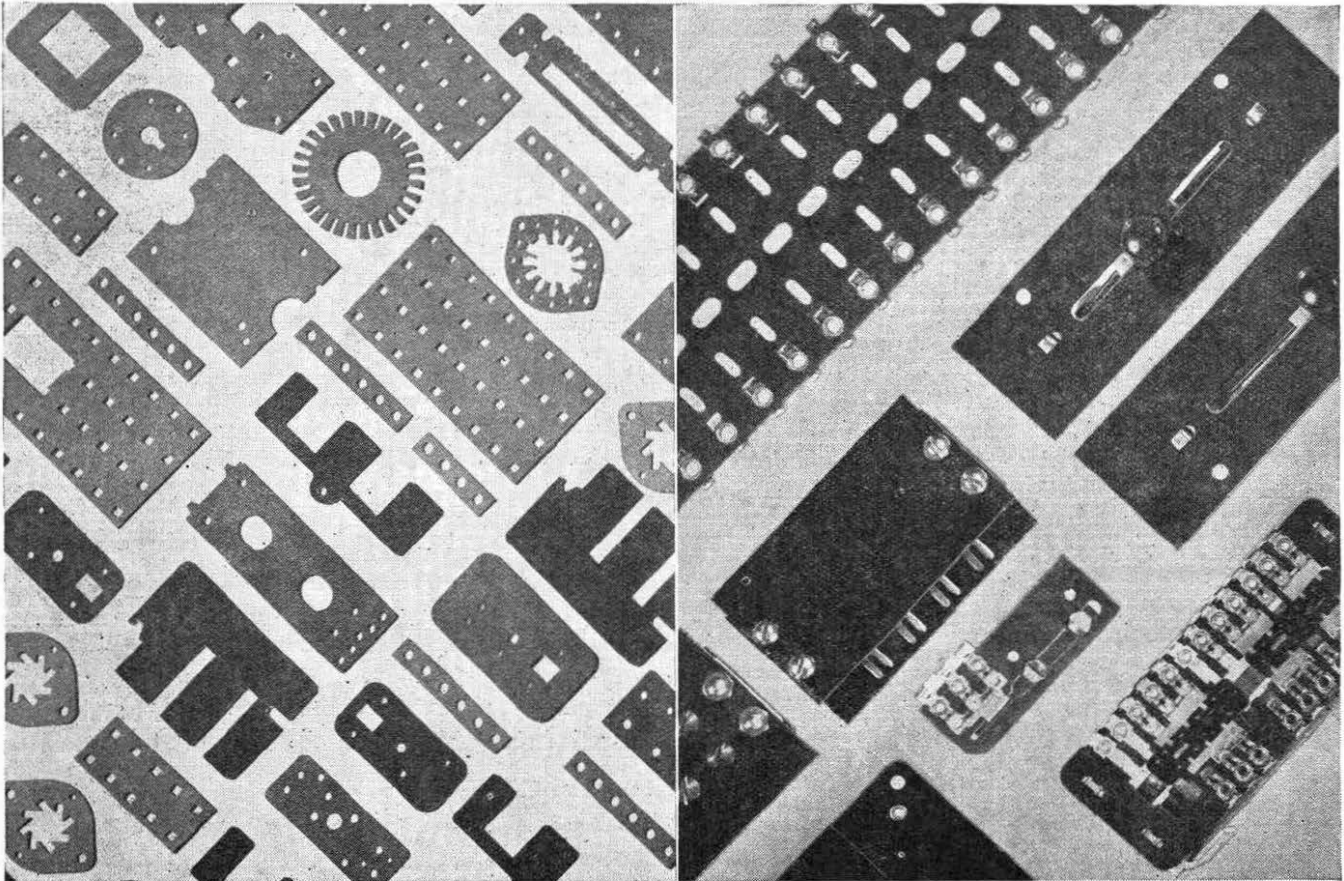

Punched electrical components showing clean finish of edges after machining of intricate parts.

Electrical terminal strips and variable resistors for radio construction.

DELARON

LAMINATED PLASTIC BOARD

THOMAS DE LA RUE & CO. LTD. (Plastics Division),
IMPERIAL HOUSE, 84/86 REGENT STREET, LONDON, W.1. Phone: REGent 2901

CARPENTER POLARIZED RELAY

TYPE 4

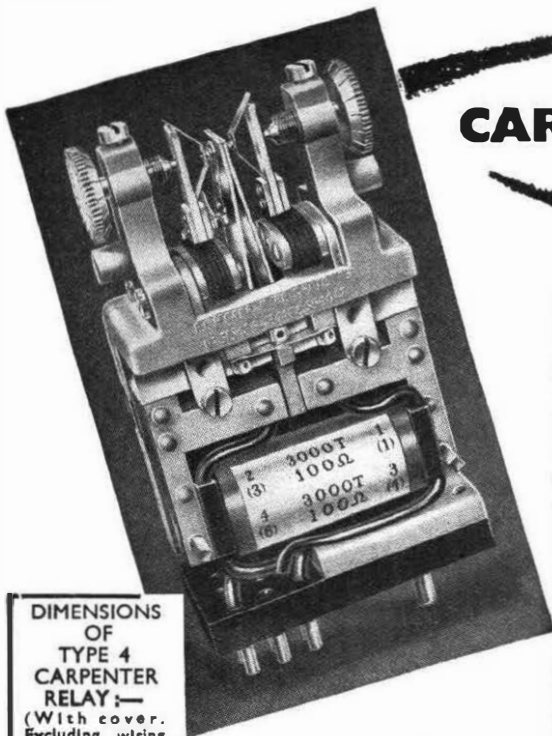

DIMENSIONS OF TYPE 4 CARPENTER RELAY:—
 (With cover. Excluding wiring tags) 3.5 ins. high x 2.2 ins. wide x 1 in. deep. Weight 13 ozs.

THIS is a medium speed, sensitive polarized relay designed primarily as a telephone impulsing relay (D.C. dialling up to 100 miles and V.F. dialling on trunk circuits). It has also been successfully adopted for use in Telex systems, but can be used satisfactorily up to speeds of 100 c/s without contact chatter or serious bias disturbances.

Its sensitivity is such that when the gap is adjusted to .004 in. nominal, the relay will just operate at 50 cycles with 3.5 ampere-turns R.M.S. (corresponding to approximately 2 mVA) or on 4.8 D.C. ampere-turns at low speeds. In service, however, the relay is normally operated at currents substantially larger than the minimum operating current quoted.

Contact chatter is absent if the contact gap does not exceed .005 in. The contact gap is adjustable by means of fine pitch screws with knurled heads marked with .001 in. divisions. Contacts on the armature tongue are insulated from it and thereby from the frame.

The relay has a magnetic screening cover with transparent removable top to facilitate contact adjustment.

Dimensionally the relay is interchangeable with the type "3000" relay and can be supplied to fit directly to the drilling normally provided for the "3000" relay.

Termination can either be made by means of a 12 in. plug base as illustrated, or with soldering tags in place of the pins.

Developed & Manufactured by the Sole Licensees:— Complete details available on request.

TELEPHONE MANUFACTURING COMPANY LTD.

Contractors to the British Commonwealth and Foreign Governments

HOLLINGSWORTH WORKS • DULWICH • LONDON, S.E.21 GIPsy Hill 2211 (10 lines)

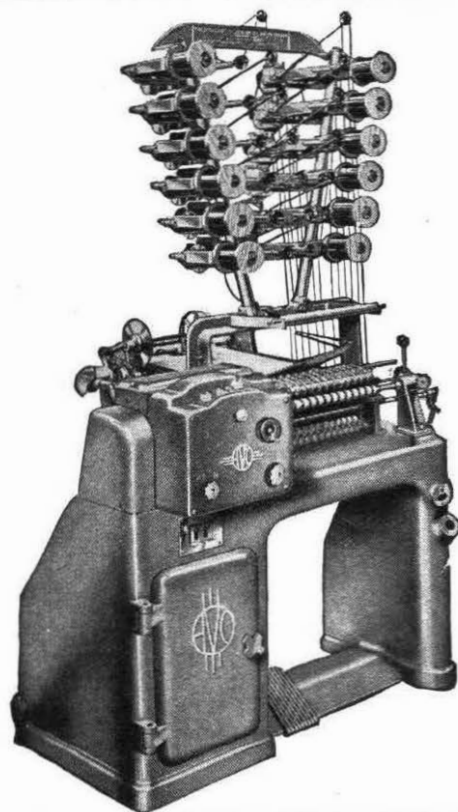

DOUGLAS AND MACADIE

Automatic COIL WINDERS

The large illustration depicts the improved "Douglas" Fully Automatic Multi-Winder, specially developed for the high-speed production of large quantities of coils with or without paper interleaving. It will produce round, square

or rectangular coils up to 6 in. each in length and up to 4½ in. diameter. As many as 12 smaller coils can be wound simultaneously within the total available winding length of 15 in. at headstock speeds of between 600 and 2,000 r.p.m.

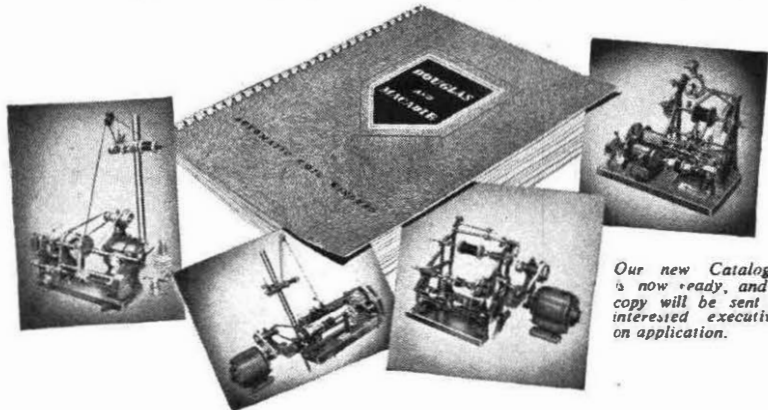

Our new Catalogue is now ready, and a copy will be sent to interested executives on application.

Sole Proprietors and Manufacturers:

The AUTOMATIC COIL WINDER & ELECTRICAL EQUIPMENT CO. LTD.
 WINDER HOUSE • DOUGLAS STREET • LONDON • S.W.1 Telephone: VICTORIA 3401/9

G.N.T.

UNDULATORS MODEL 309 * 310

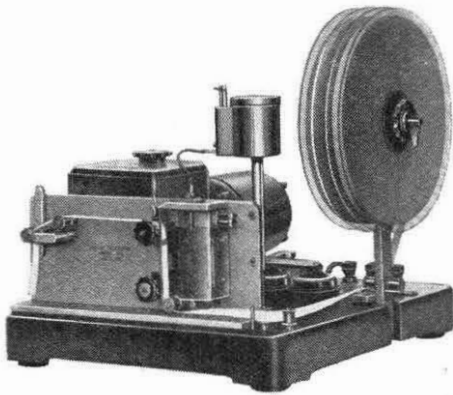

Model 309 is fitted with a single recording part while model 310 has two recording parts and is useful in connection with diversity reception.

Both models can record signals up to 300 w. p. m. Supplied with A. C. or D. C. motors as required.

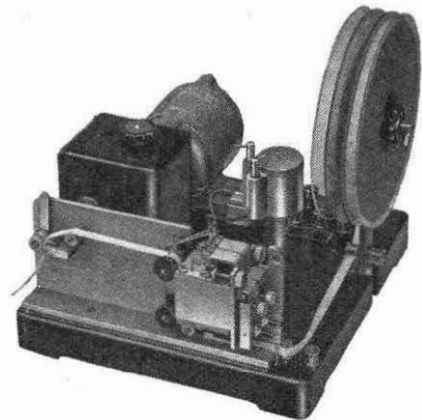

* Write for comprehensive catalogue.

THE GREAT NORTHERN TELEGRAPH COMPANY'S FACTORY

4, SYDHAVNS PLADS
COPENHAGEN SV . DENMARK

LONDON OFFICE: 5, ST. HELENS PLACE
LONDON E.C.3.

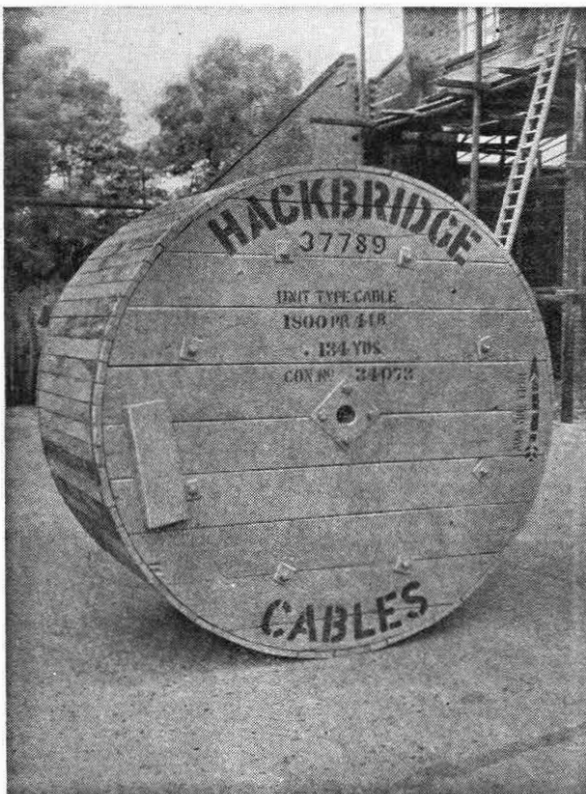

BEYOND THE BUTTON....

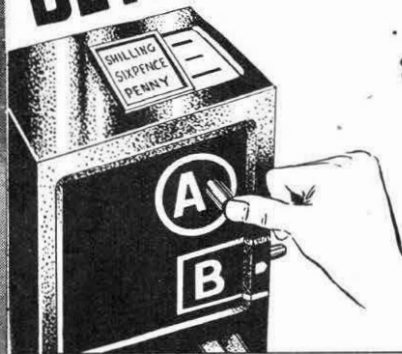

.... Hackbridge underground dry-core air-space lead covered and armoured cable.
Contractors to G.P.O.,
British Railways, British
and Colonial Govern-
ment Departments.



HACKBRIDGE

Cable Company Limited

KELVIN WORKS, HACKBRIDGE, SURREY

In Association with Bryce Electric Construction Company Ltd.

Branches at:

Birmingham, Bristol, Cardiff, Manchester, Newcastle, Sheffield

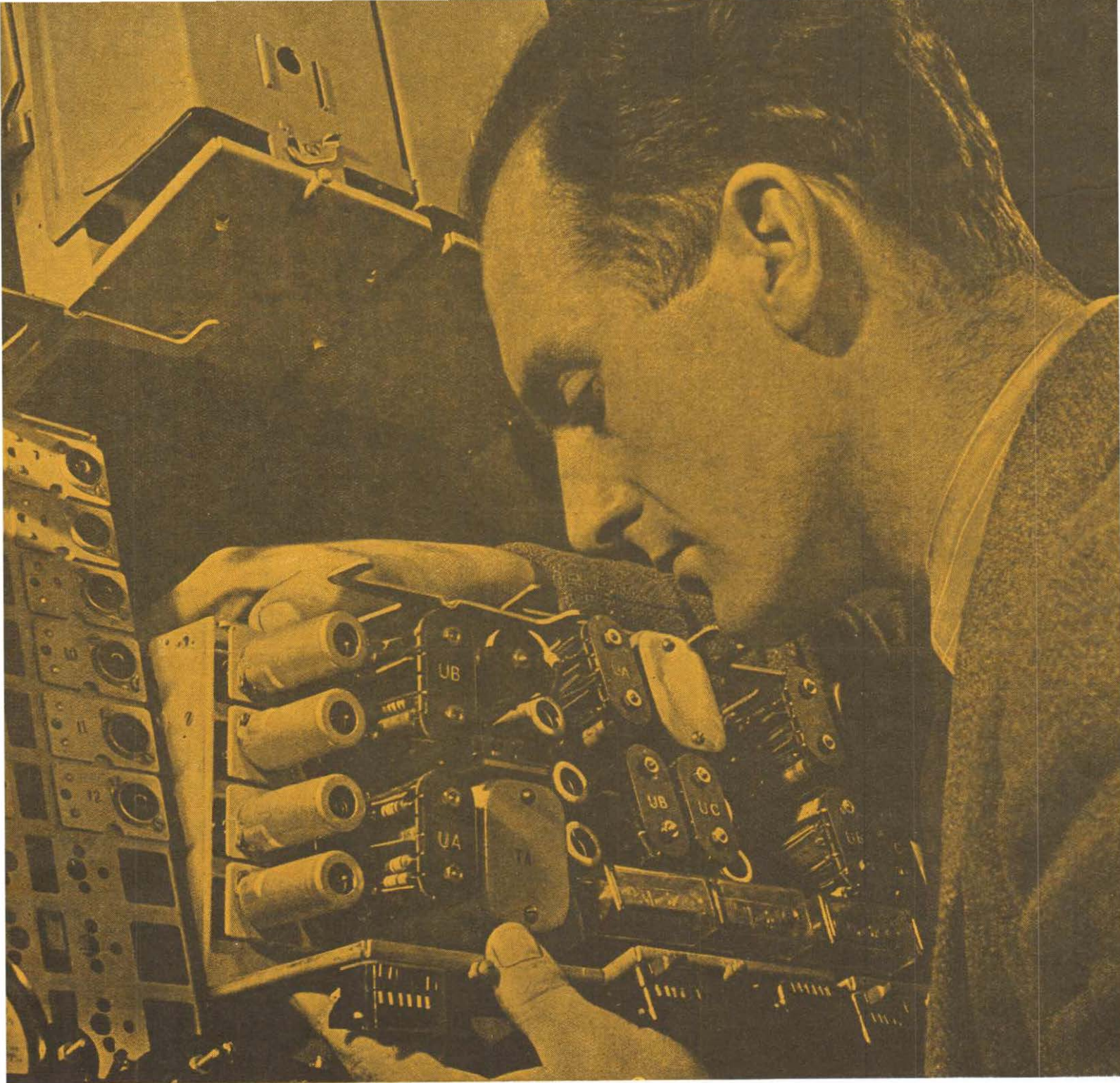

PRODUCTS OF THE COMPANY INCLUDE: DIRECTOR AND NON-DIRECTOR AUTOMATIC TELEPHONE EXCHANGE EQUIPMENT, AUTOMATIC TRUNK EXCHANGES, RURAL AUTOMATIC EXCHANGES, PRIVATE AUTOMATIC EXCHANGES, PRIVATE AUTOMATIC BRANCH EXCHANGES, OPEN WIRE, CABLE AND RADIO TRANSMISSION EQUIPMENT; INTERCOM KEY-CONTROLLED TELEPHONE EQUIPMENT, CENTRALISED SUPERVISORY REMOTE INDICATION AND CONTROL EQUIPMENT; "RYTHMATIC" RIPPLE CONTROL EQUIPMENT; "ELECTRO-MATIC" VEHICLE-ACTUATED TRAFFIC SIGNALS; MINE TELEPHONES AND COLLIERY SIGNALLING EQUIPMENT.

*Inserting a small single frequency
V.F. receiver, incorporating miniature
valves, into a laboratory check position*

Remember



Generously
SAT-NOV 10

From First Principles to Finished Product

The principles of thermionic emission were first studied by Richardson in 1902 and 3 years later were applied in the design of the thermionic valve by Fleming and de Forest. This invention made possible long distance speech communication and to-day is an essential component of all telecommunications equipment. In the special electronic division (Hivac Ltd.) maintained by Automatic Telephone & Electric Co. Ltd., continuous research on valve technique is carried out and new applications are constantly being sought, a recent example being the employment of valves as electronic relays in automatic telephone switching systems.



AUTOMATIC TELEPHONE & ELECTRIC CO. LTD.

Export Department: Strowger House, Arundel Street, London, W.C.2. Telephone: TEMple Bar 9262.

Cablegrams: Strowgerex, London. Strowger Works, Liverpool, England

backbone of Britain's

LIFELINES of Britain's industry and commerce, the cable network throughout these islands forms the basis of the world's finest system of communication, in the development of which *Standard* design, research and manufacturing skill have contributed so much.

Rooted in telephony's earliest days, *Standard's* achievement, which has helped to bring our major communication channels to their present high level of efficiency, has led the way with the first production of the multi-conductor and coaxial cables for carrier telegraphy, telephony, coaxial telephony and television which to-day link our cities and our important towns.



LOCAL OR EXCHANGE AREA CABLES

These cables are used for connecting subscribers to central offices or for junctions between central offices. Cables can be supplied in concentric layer construction for both star-quad and pairs, and in multiple unit formation for paired cables.

LONG-DISTANCE AUDIO-FREQUENCY CABLES

These cables are of the type normally used with loading coil for long-distance voice-frequency operation. They are paper insulated cables in either star-quad or multiple twin formation. Since these cables are used for long distance working, the design is such that the various combinations of capacitance unbalance and resistance unbalance are reduced to a minimum.

MULTI-CONDUCTOR CARRIER-FREQUENCY CABLES

These are paper-insulated lead-covered cables for the provision of 12 or more carrier channels on each pair of conductors. Two cables are required, one for each direction of transmission. The conductors are arranged in star-quad formation and the cable is specially designed to obtain impedance uniformity and minimum crosstalk between the circuits in the cable.

COAXIAL CABLES

For broad-band carrier telephony or television transmission *Standard* have developed the type 375 PDW coaxial cable. The cable is normally used in composite form, 2, 4, 6 or 8 cores being laid up together with paper-insulated quads, the latter being for service and control purposes between the main and unattended intermediate repeater stations.

SPECIAL CABLES

The London-Birmingham Television Cable is an outstanding example of special cables which *Standard* have developed and manufactured. This cable incorporates two 0.975 in. and four 0.375 in. coaxial tubes and may ultimately be equipped to transmit very high definition monochrome or colour television signals simultaneously with present definition television signals.

Standard Telephones and Cables Limited

Registered Office : Connaught House, Aldwych, London, W.C.2

CABLES *by Standard*

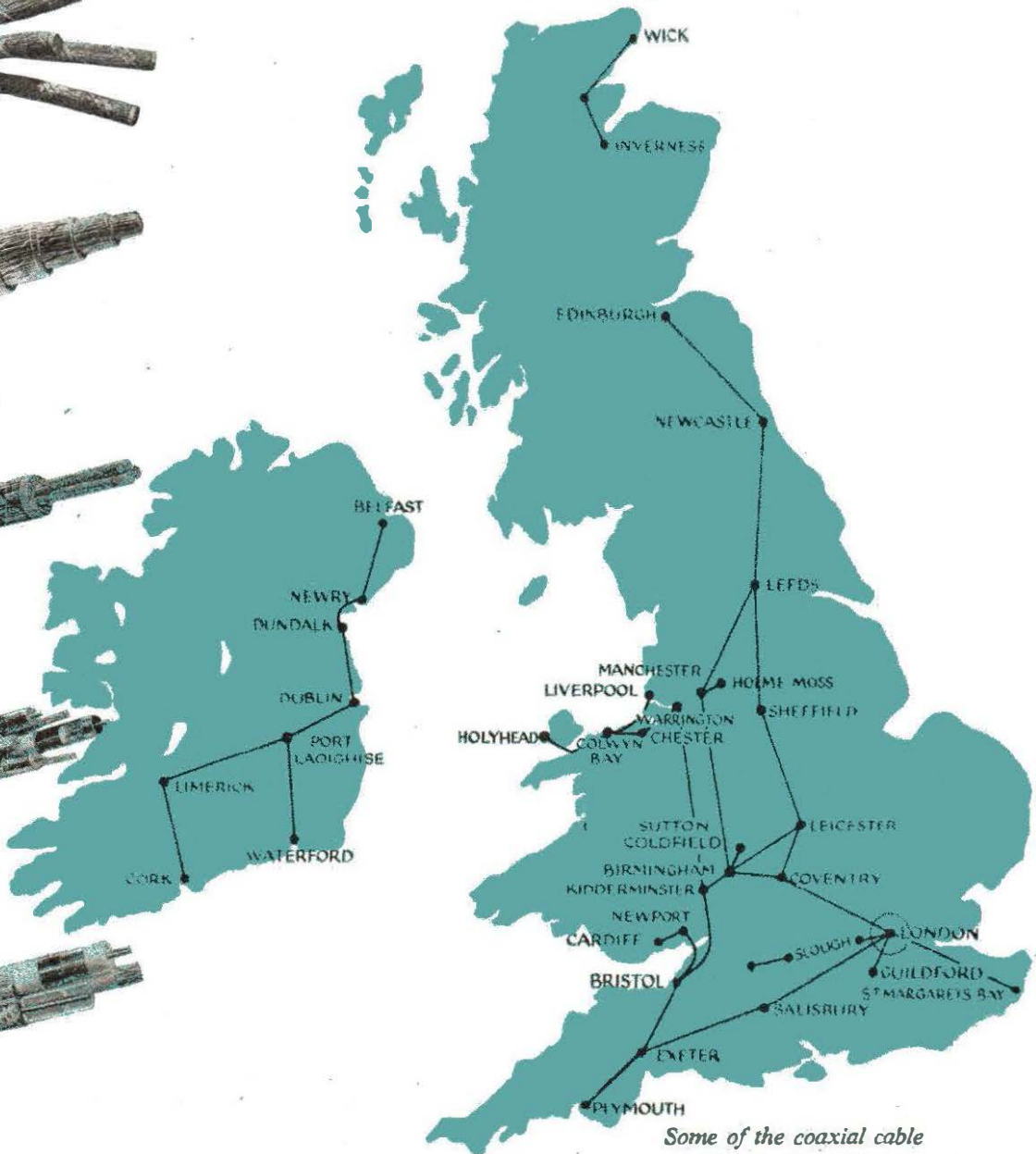

Some of the coaxial cable routes by STANDARD

TELEPHONE LINE DIVISION

North Woolwich, London, E.16 ALBert Dock 1401



- The Anglo-Dutch No. 5 Cable, which spans the North Sea from Aldeburgh to Domburg, has been provided with four submerged repeaters at intervals of approximately 16 nautical miles. This coaxial cable is 80 nautical miles long and normally carried the equivalent of 10 telephone circuits. The addition of these four repeaters increases the traffic capacity of this cable to 60 circuits.
- This is the first coaxial submarine cable from these shores to be fitted with submerged repeaters connected in tandem, and is the first of a number of such projects.
- The construction of the repeaters was undertaken by the Company to the order of the British Post Office whose Research Branch provided the basic electrical designs to meet the cable requirements. The illustration shows one of the units being lowered into a barge moored alongside the wharf at our Woolwich Works, prior to loading on to the P.O. Cable Ship "Alert" which carried out the laying operations.

SIEMENS BROTHERS & CO., LIMITED
WOOLWICH • LONDON • S. E. 18.

MODERN CAPACITOR ENGINEERING

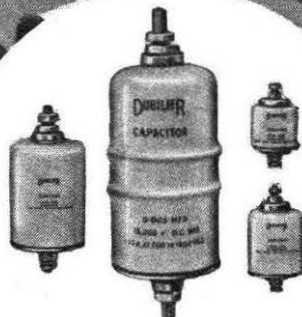
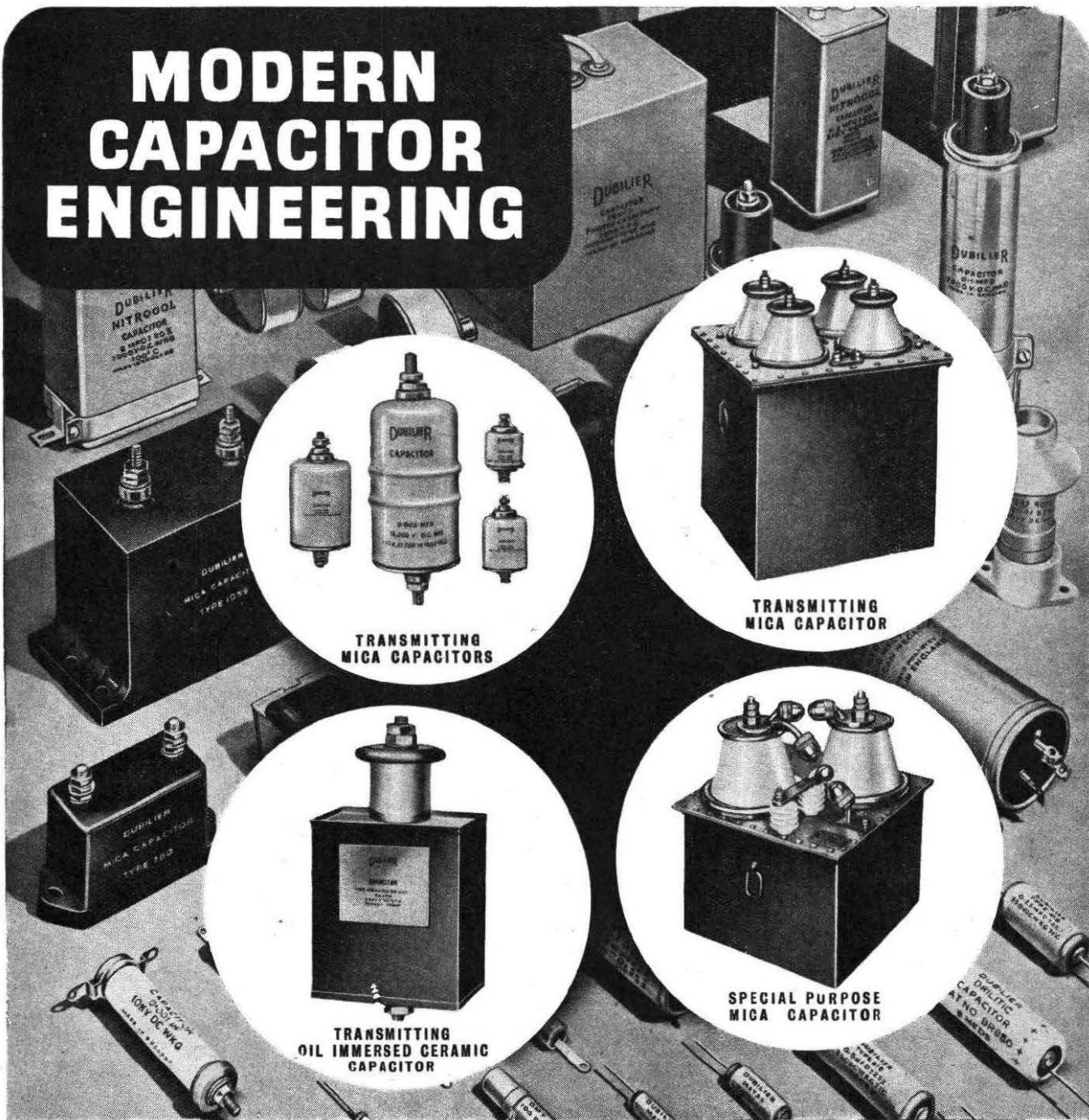

TRANSMITTING
MICA CAPACITORS

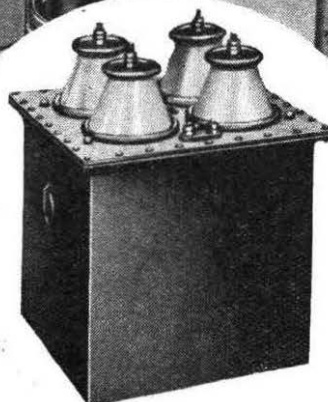

TRANSMITTING
MICA CAPACITOR



TRANSMITTING
OIL IMMERSED CERAMIC
CAPACITOR

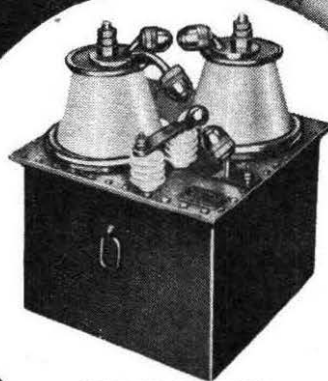

SPECIAL PURPOSE
MICA CAPACITOR

DUBILIER CAPACITORS

Dubilier provide the most comprehensive range of Capacitors available today for Radio Transmitting and Receiving, in addition to Capacitors for Electronic and Industrial engineering.

Dubilier Capacitors are designed and manufactured to

a high standard of specification, suitability of purpose and meticulous capacitor engineering, and they satisfy the exacting demands of the British Postal Authorities whom we are proud to number amongst our customers.

Full details and technical service upon request.

DUBILIER CONDENSER CO. (1925) LTD., DUCON WORKS, VICTORIA ROAD, N. ACTON, LONDON, W.3.

'Phone: Acorn 2241 (5 lines). Cables: Nivoltcon, London. Marconi International Code. 'Grams: Nivoltcon. Wesphone, London.

An announcement of telephone administration

The Strowger selector retained its original form for many years. About fifteen years ago, a new pattern was introduced and became known as the British Post Office Type 2000. The General Electric Company was able to supply either, but immediately after the war, work began on a new design to combine the advantages of both and to incorporate features never before included in a two-motion selector. The result is the new G.E.C. Selector SE50.

The new selector, with its associated relays on a standard plate, jacks in to replace the 2000 type on existing designs of shelf. It therefore has a marked similarity of appearance, but there the similarity ends. The design gives Telephone Administrations the most valuable features in any such mechanism—reliability of operation combined with ease and positiveness of adjustment.

ADJUSTMENTS

With a datum pin inserted in a specially-prepared position, mechanical adjustments are made with an ease and accuracy previously unknown. All operational adjustments are made from the front with the selector in position on its shelf. No adjustment is dependent upon or affected by another; so independent are they, in fact, that each magnet assembly could be removed, adjusted, and replaced without upsetting any other adjustment.



MAGNETS

Vertical and rotary magnets are of the powerful closed magnetic circuit type used so successfully in the new G.E.C. uniselectors.

RELEASE MAGNET

A release magnet is fitted and gives the selector a minimum releasing time, allowing it to be used for digit absorption.

The Largest British Manufacturing Organisation

THE GENERAL ELECTRIC COMPANY LTD. OF ENGLAND.

TELEPHONE RADIS & TELEVISION WORKING CURRENTS, ENGLISH ELECTRIC, FUSION, GAS, HIGH VOLTAGE, LIGHTING & CABLES, INSTRUMENTS, MECHANICAL
WEAR OFFICE, MAINLINE EQUIPMENT, INDUSTRIAL AUTOMATION, AIRCRAFT, MARINE, RAILWAYS, ELECTRICITY, TELEVISION, TELECOMMUNICATIONS, TRANSMISSION, WIRELESS
LONDON, LEITH, NEWCASTLE, GLASGOW

great importance to tions...

THE NEW **G.E.C.** SELECTOR

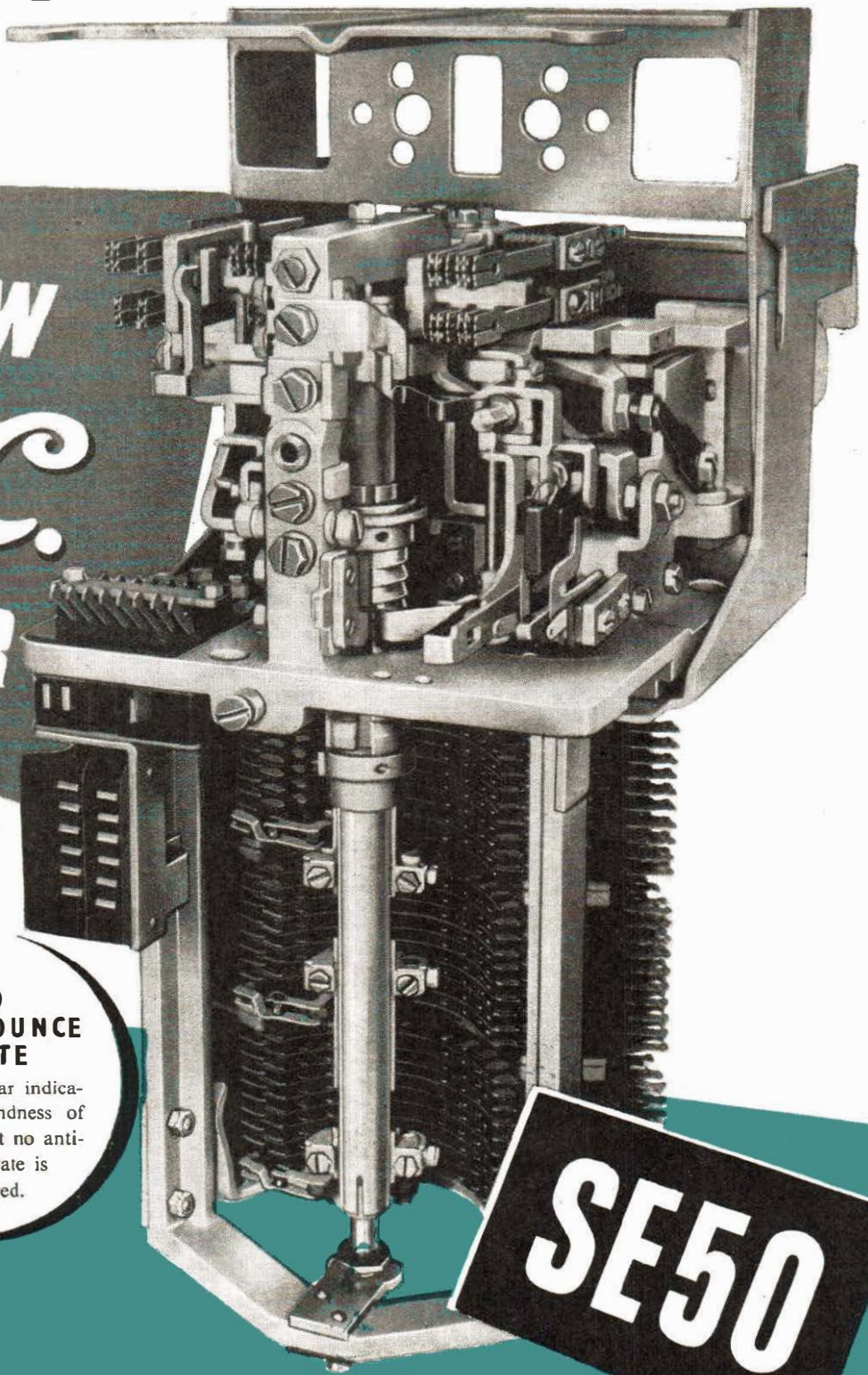

WIPERS

A new design of wiper assembly gives a wiper life of at least 1,000,000 calls with normal maintenance attention.

NO ANTI-BOUNCE PLATE

One particular indication of soundness of design is that no anti-bounce plate is required.

SE50



These and many other features of the new selector are described in Leaflet SEL 1. Copies will be forwarded to Telephone Administrations on request.



Undoubtedly the most dependable source of D.C. power supply, Westinghouse metal rectifiers are applied extensively in communication engineering, where absolute efficiency and reliability is essential. Employed in telephone and telegraph circuits, they are used either for charging the batteries of the apparatus or operating it direct from A.C. mains. They are installed in transmitting and receiving stations, and numerous other applications include spark quenching, rectifying voice and radio frequency currents and for polarising and slugging standard relays in telephone and telegraph circuits.



METAL RECTIFIERS

Write for Publication M.R.9 to Dept. P.O. 10.

WESTINGHOUSE BRAKE & SIGNAL CO. LTD. 82, York Way, King's Cross, London, N.1

DECADE RESISTANCES

in 3 Grades guaranteed

0.01% 0.03% 0.1%

SUPPLIED BOXED OR FOR
CLIENT'S OWN PANEL

HIGHLY LAMINATED BRUSHES

LOWER DECADES OF ABSOLUTELY
CONSTANT INDUCTANCE

EQUALLY SUITABLE FOR HIGH FREQUENCY
LOW FREQUENCY OR DIRECT CURRENT

Electrical Standards for Research and Industry

Testing and Measuring Apparatus
for Communication Engineering

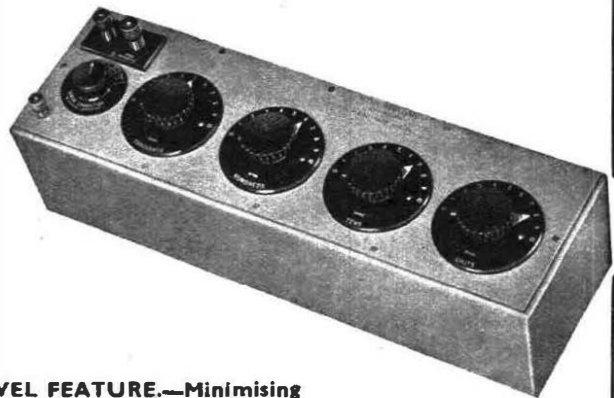

A NOVEL FEATURE.—Minimising the Residual Inductance and High Frequency Resistance Error.

A patented method of reactance compensation is employed on the higher decades which compensates automatically for the screen capacitance and so renders the effective residual inductance sensibly independent of the method of screen connection. In addition, the user may, at will by the simple operation of a switch, adjust the reactance or resistance error sensibly to zero at the higher frequencies.

H. W. SULLIVAN
— LIMITED —

LONDON, S.E.15

Telephone: New Cross 3255 (P.B.X.)

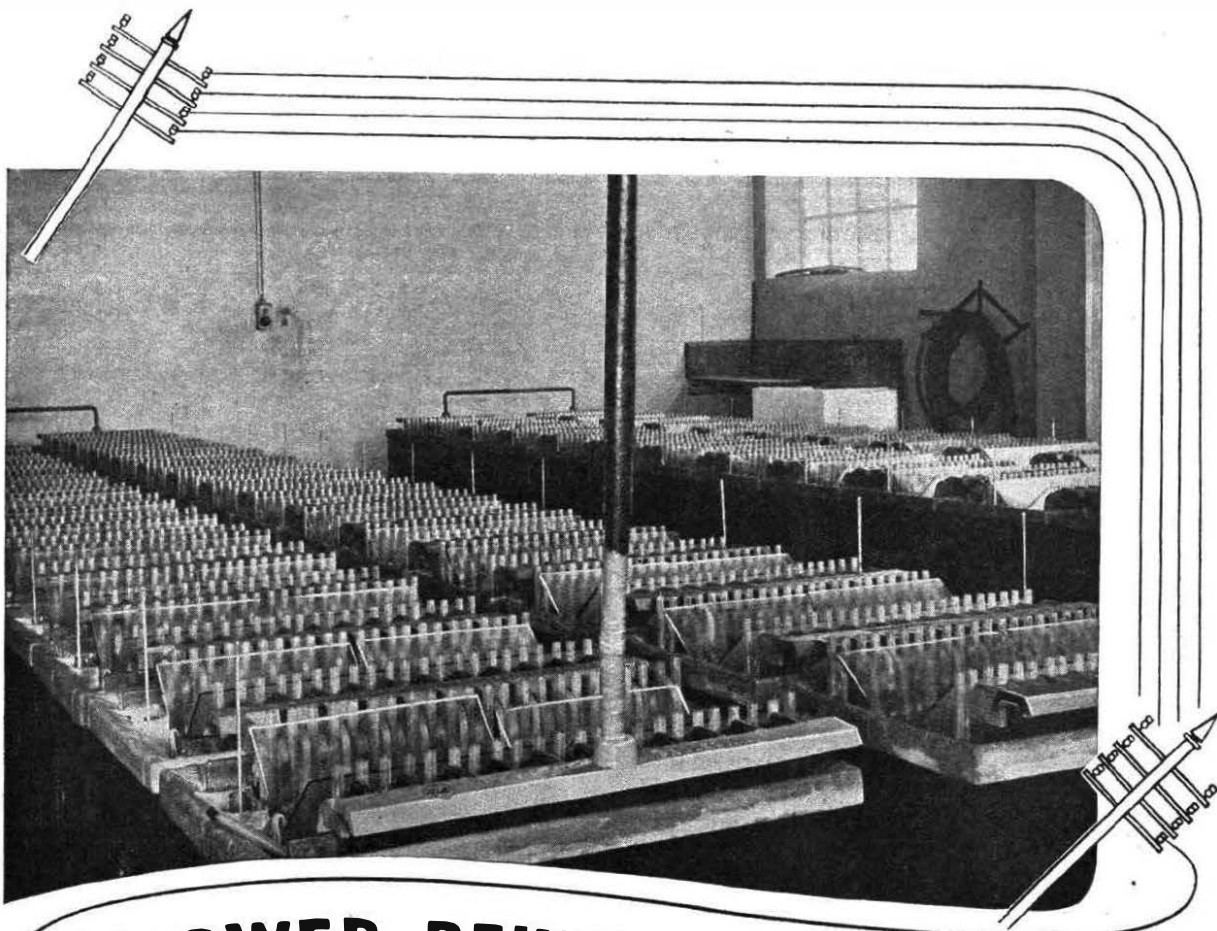

POWER BEHIND THE LINES

TUNGSTONE PLANTÉ CELLS are being supplied to the British Post Office and Post and Telegraph Departments in many countries overseas. They conform fully to G.P.O. and British Standard specifications.

OPEN TYPE CELLS

Similar to the illustration above, these are available in glass and/or lead lined wooden boxes in capacities from 100 a.h. to 500 a.h.

REPLATALS

We are in a position to supply plates for the replating of any existing Planté Battery.

ENCLOSED TYPE CELLS

As illustrated on the right, these are in moulded glass boxes with sealed-in lids. Capacity range from 10 a.h. to 200 a.h.

HIGH VOLTAGE TELEPHONE BATTERIES

Portable Type. Standard layout for 50 volts, in waxed hard wood crates, exactly to the requirements of the G.P.O.

Overseas customers are invited to cable or write their enquiries for batteries or parts. Visitors to London are welcome at our offices.

TUNGSTONE Batteries

For further particulars write : **TUNGSTONE PRODUCTS LIMITED**
10 SALISBURY SQUARE · LONDON · E.C.4 · ENGLAND. Cables: "Dilutum" London.



T.B.12

PITMAN'S

for Technical Books

Electrical Engineering Theory and Practice (3 vols.)

By Philip Kemp, M.Sc.Tech., M.I.E.E.; assisted by over 40 contributors. An up-to-date library of information on all aspects of electrical engineering. Nearly 2,000 quarto pages; over 2,000 illustrations. Per set, £10 net.

Telephony (2 vols.)

By J. Atkinson, A.M.I.E.E., Area Engineer, Post Office Engineering Dept. A standard textbook for post office engineers and students. Over 1,500 illustrations. Vol. I (General Principles and Manual Exchange Systems), 35/- net. Vol. II (Automatic Exchange Systems), 50/- net.

Telecommunications Principles

By R. N. Renton, A.M.I.E.E. A new work covering the syllabus for the City and Guilds examinations in Telecommunications Principles, Grades I, II and III. Illustrated. 37/6.

Transients in Electric Circuits

Using the Heaviside Operational Calculus

By W. B. Coulthard, B.Sc.Eng., A.M.I.E.E., M.A.I.E.E. Second Edition. Illustrated. 32/6 net.

Electrical Measurements and Measuring Instruments

By E. W. Golding, M.Sc.Tech., A.M.I.E.E. A useful textbook covering the syllabuses of the B.Sc.Eng. and other examinations. Third Edition. 27/6 net.

PITMAN, Parker Street, Kingsway, London, W.C.2

SUCCESS?

The demand for qualified technicians to fill well-paid industrial posts grows daily. An E.M.I. course of training is your quickest way to a key position. Our Home Study courses cover all the subjects listed below. As part of the great E.M.I. Group ("H.M.V.", Marconiphone, etc.), we have first-hand knowledge of the Technical Training required in modern industry. No other college can offer you such a practical background of industrial experience.

POST THIS COUPON NOW

E.M.I. INSTITUTES, Postal Division, Dept. 22,
43, GROVE PARK ROAD, CHISWICK, LONDON, W.4.

Please send, without obligation, your FREE BROCHURE
I have marked the subjects which interest me.

Mechanical Eng. Electrical Eng. Draughtsmanship
 Radio Television Production Eng. Automobile Eng.
 Aeronautical Eng. General Cert. of Education (Metric.)
 Civil Service. Also Courses for A.M.I. Mech.E., A.M.I.C.E.,
A.M.Brit.I.R.E., A.F.R.Ae.S., CITY and GUILDS EXAMS. in Mech. Eng.,
Elect. Eng., Telecommunications, etc. Other Subjects.....

NAME (Capitals).....

ADDRESS (Capitals).....

START
HERE



E.M.I. INSTITUTES — The College backed by an Industry

L39A

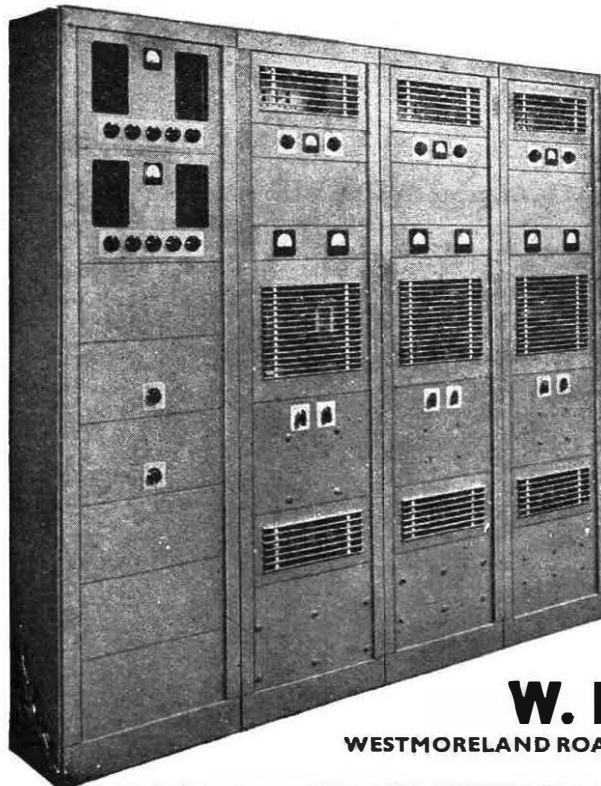

The Mark II series of SAVAGE AMPLIFIERS for Broadcast Relay

● These Amplifiers are examples of what careful design can achieve. A lift-off back panel affords immediate access for maintenance purposes and the removal of six screws releases the side covers of the rack and exposes all the interpanel wiring. Even when the rack is sandwiched between others the side covers can be moved just as easily. All valves are accessible from the front of the rack, and are protected by quick release grilles. The rack is completely flat fronted. The general appearance is further enhanced by the absence of a projecting front foot, and the masking of all panel fixing bolts. Similar racks carrying auxiliary apparatus can be placed side by side with amplifiers so that the whole installation is uniform in appearance.

Complete specifications available on request.

W. BRYAN SAVAGE LIMITED

WESTMORELAND ROAD · LONDON N.W.9 · TELEPHONE: COLINDALE 7131

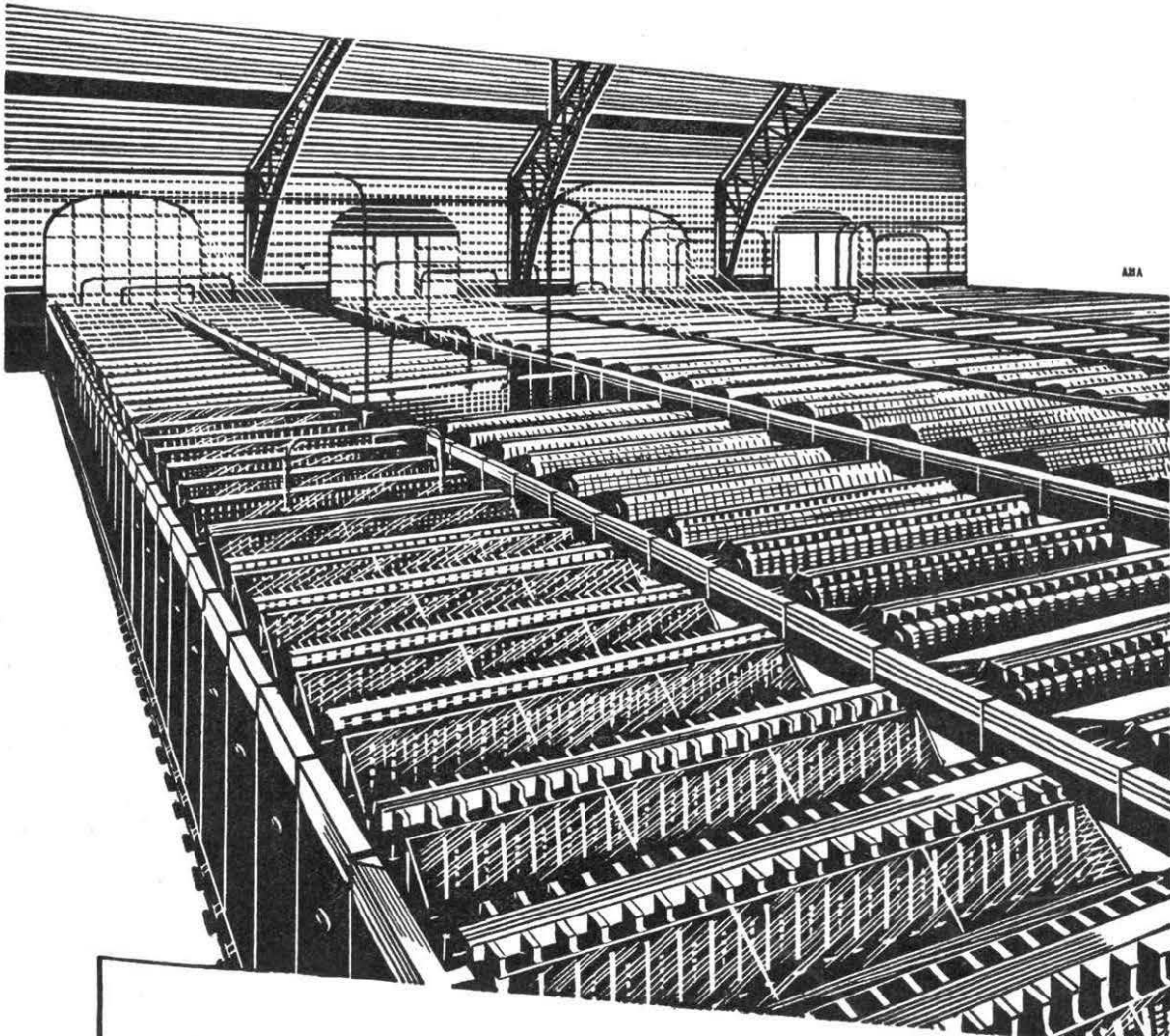

Alton is a big name in the export market. These good batteries, in capacities from 10 to 15,000 ampere-hours, are in service in sixty-five countries. Alton is ready to meet orders from any part of the world and to give firm delivery dates

ALTON

**BATTERIES OF
MERIT**

THE ALTON BATTERY COMPANY LIMITED
Alton, Hants. Telephone: Alton 2267 and 2268
Telegrams: Battery, Alton

Alton can also supply renewal plates for all makes of battery, British & Continental

Creed



No. 47 Tape Model Teleprinter

No. 7 Page Model Teleprinter

**printing
telegraph
systems**

Creed & Company Limited
TELEGRAPH HOUSE · CROYDON · ENGLAND



gives **3-FOLD** Protection for all Metalwork above or below ground.

Denso Permanently Plastic Tape seals pipes, mains, cables and all metal structures—exposed or buried—from the menace of chemical and electrolytical corrosion.

Indispensable for sealing cable ends—the temporary repair of fractured gas-mains—and a real aid to frostproofing.

Full technical details of Denso Anti-corrosive and Sealing Products gladly supplied.

WINN & COALES LTD.

DENSO WORKS, CHAPEL ROAD, LONDON, S.E.27.

Telephone : GIPsy Hill 4247/8.

Telegrams : Denselte, Westnor, London.

SOUND INSTRUCTION by Postal Method

The I.C.S., largest school in the world devoted to spare-time training by the postal method, offers you highly specialised Courses for the following examinations:

- P.M.G. Certificates for Wireless Operators.
- C. & G. Illumination Engineering (Inter.)
- C. & G. Electrical Engineering Practice, Installation and Telecommunications.
- Graduateship of the B.I.R.E.

I.C.S. Examination students are coached till successful.

Other Courses meet the requirements of all who desire to qualify for responsible positions in Electric Power, Illumination, Heating and Traction Systems. Equally successful is our instruction for Telegraph and Radio Engineers, Radio Servicemen, and in Elementary Radar and Electronics, Advanced Short-Wave Radio and Television Technology.

Instruction is by correspondence from textbooks specially prepared by many experts.

WRITE FOR OUR SPECIAL BOOKLET and state the particular subject or Examination in which you are interested.

Generous Discount granted to members of H.M. Forces.

YOU MAY USE THIS COUPON

International Correspondence Schools Ltd.

Dept. 108, International Buildings, Kingsway, London, W.C.2

Please send me, free of charge, your special booklet on

Name

(BLOCK LETTERS, PLEASE)

Age

Address

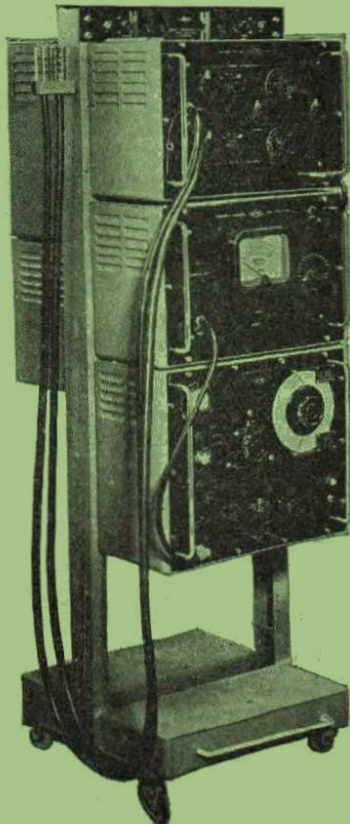

PHASE MEASURING EQUIPMENT

Type RX 103

This equipment, which is based upon a Post Office design, is primarily intended for the measurement of the phase-shift and gain of the $\mu\beta$ characteristics of feedback repeaters, over the frequency range of 50 kc/s to 20 Mc/s. It is also suitable for similar measurements on amplifiers, filters, equalisers and other four-terminal networks.

AIRMEC LABORATORIES LTD

HIGH WYCOMBE · BUCKINGHAMSHIRE · ENGLAND

TEL. HIGH WYCOMBE 2060

CABLES: AIRMEC HIGH WYCOMBE

S.A. (6) 4

TELEPHONE CABLES

OUR TELECOMMUNICATION CABLES CATALOGUE, GIVING INFORMATION AND SPECIFICATIONS FOR A WIDE RANGE OF TELECOMMUNICATION CABLES MANUFACTURED BY US, IS AVAILABLE UPON REQUEST.

TELEPHONE:
SOUTHAMPTON
2141 (5 lines)

IRELLI-GENERAL
CABLE WORKS, Ltd., SOUTHAMPTON.

TELEGRAMS
"PICEKAYBEL"
SOUTHAMPTON

EDISWAN

Telephone Line Protectors

FOR THE PROTECTION OF LINES OF
COMMUNICATION FROM SURGES INDUCED
BY LIGHTNING OR FAULTS ON
NEIGHBOURING POWER LINES

Ediswan Telephone Line Protectors have now been in commission for nearly twenty years. They have proved their worth in all parts of the world and are being called for and installed in ever increasing numbers. Many thousands were employed during the war years for the protection of vital lines of communication and were eminently successful. Reports of their outstanding merit and successful operation continue to reach us and in recent years they have proved of particular interest for protection against surges caused by lightning discharges.

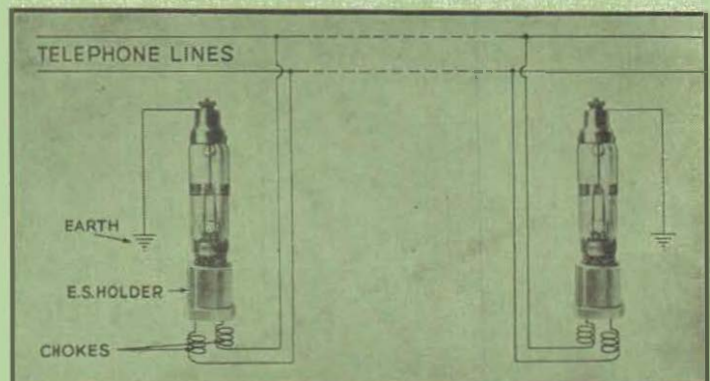

Continued research has enabled us to patent a further improvement which removes any suggestion of delay in operation.

Further information and prices on application.

THE EDISON SWAN ELECTRIC CO. LTD., 155 CHARING CROSS ROAD, LONDON, W.C.2
Member of the A.E.I. Group of Companies

Printed by SANDERS PHILLIPS & CO., LTD., The Baynard Press, Chryssell Road, London, S.W.9. and
Published by BIRCH & WHITTINGTON (Prop. Dorling & Co (Epsom), Ltd.), Epsom, Surrey.

T.E.3