

# THE POST OFFICE ELECTRICAL ENGINEERS' JOURNAL

**VOL. 43**

**APRIL 1950**

**PART 1**

## CONTENTS

	PAGE
A REFERENCE TELEPHONE SYSTEM FOR ARTICULATION TESTS—J. Swaffield and R. H. de Wardt .. .. .	1
IMPROVED METHOD OF CABLE BUOY RECOVERY .. .. .	8
A SURVEY OF MODERN RADIO VALVES—Part 4—Transmitting Valves for use up to 30 Mc/s.—K. D. Bomford, M.Sc., A.M.I.E.E., and A. H. F. Hunt .. .. .	10
THE RECOVERY OF TWO TIMBER LATTICE MASTS—Capt. S. Helm. A.M.I.E.E. .. .. .	16
AN ELECTRONIC DISTORTION MEASURING SET FOR START-STOP TELEGRAPH SIGNALS—L. K. Wheeler, B.Sc.(Eng.), A.M.I.E.E., and R. S. Tissington, B.Sc.(Eng.), A.M.I.E.E. .. .. .	18
TELEVISION RADIO-RELAY LINKS—A. H. Mumford, O.B.E., B.Sc.(Eng.), M.I.E.E., and Capt. C. F. Booth, O.B.E., M.I.E.E. .. .. .	23
TESTING FACILITIES IN H.M.T.S. MONARCH—P. R. Bray, M.Sc.(Eng.), A.M.I.E.E. .. .. .	36
A METHOD OF REDUCING THE VIBRATION FROM DIESEL ENGINE GENERATING SETS—J. H. Alderson, M.A., A.M.I.E.E. .. .. .	43
NOTES AND COMMENTS .. .. .	50
INSTITUTION OF POST OFFICE ELECTRICAL ENGINEERS .. .. .	50
REGIONAL NOTES .. .. .	51
JUNIOR SECTION NOTES .. .. .	54
STAFF CHANGES .. .. .	57
BOOK REVIEWS .. .. .	7, 17, 22, 35, 48

Price 1/6 net

**THE INSTITUTION OF POST OFFICE ELECTRICAL ENGINEERS**



STUDY  
AT  
HOME

You Can Have a College Training  
For a Few Shillings Monthly

IN YOUR  
SPARE  
TIME

## CITY and GUILDS (Telecommunication) EXAMINATIONS

To every student we send  
a written Guarantee of  
Tuition until the  
examination is  
actually  
passed

*The most progressive and most successful  
Correspondence College in the world*

Our  
tuition  
is so graded  
that each stage  
is reached without  
difficulty.

Personal attention is given  
to every student.

FULL PARTICULARS AND  
ADVICE SUPPLIED FREE.  
WE TEACH BY POST IN ALL  
PARTS OF THE WORLD.



Dept. 24, THE BENNETT COLLEGE, SHEFFIELD

## ● PROCESS TIMERS



Spelling and Sequence  
Timers, etc. Cycling  
and Hand or Auto  
Re-setting. Periods  
1/10th second to a week.

Ask for leaflet PT/PO

## ● PHOTO-ELECTRIC APPARATUS

COUNTS  
CONTROLS  
PROTECTS

Ask for leaflet 108/PO



## ● RELAYS

Mercury-Switch, Miniature, Latching, Stepping,  
Differential, Sensitive and other types.

# LONDEX LTD.

Manufacturers of Remote Control Apparatus

207 ANERLEY ROAD, LONDON, S.E.20 Tel.: SYDenham 6258

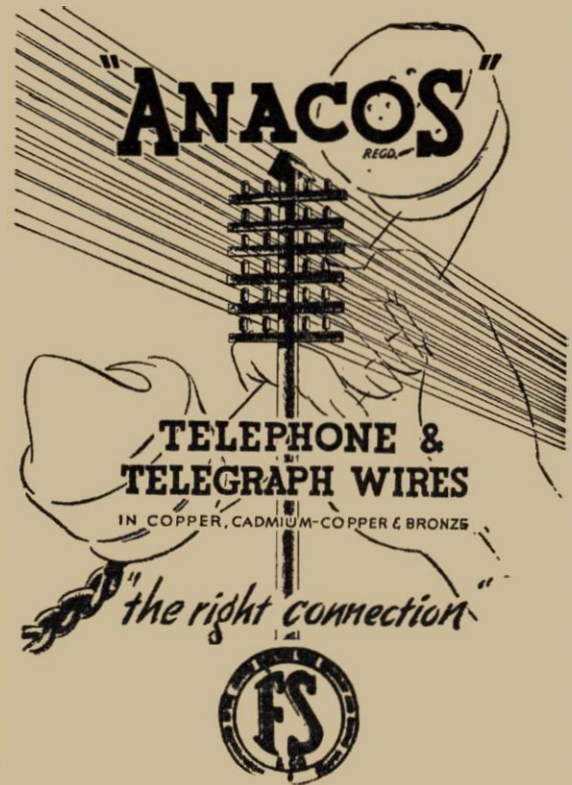

FREDERICK SMITH & COMPANY

(Incorporated in The London Electric Wire Company and Smiths, Limited)  
ANACONDA WORKS, SALFORD 3, LANCs.  
Phone: Blackfriars 8701 (9 lines) • Grams: "Anacoda," Manchester

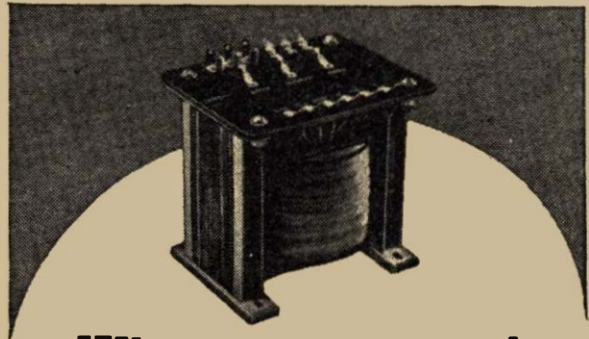

## When an unusual Specification is required.

We can give you the benefit of 20 years' experience  
in transformer construction and design. We manu-  
facture quantities but we do NOT mass produce.  
Every Instrument is built to suit your most exacting  
individual specification.

Send your enquiries for the personal attention of  
our Mr. W. Bryan Savage.



SAVAGE TRANSFORMERS LTD. • NUBSTRED ROAD, DEVIZES, WILTS.

# THE POST OFFICE ELECTRICAL ENGINEERS' JOURNAL

Vol. 43

April, 1950

Part I

## A Reference Telephone System for Articulation Tests

J. SWAFFIELD, and  
R. H. de WARDT

U.D.C. 621.395 : 534.78

The C.C.I.F. is studying the possibility of using ratings based on articulation measurements, as distinct from the volume ratings (reference equivalents) at present in use, for specifying the standard for international telephone transmission. The British Post Office has recently supplied a high quality reference telephone transmission system for use in developing and maintaining such a standard. The reference system and associated apparatus (known collectively as the ARAEN) are now installed and in use at the C.C.I.F. Laboratory in Geneva.

### Introduction.

THE Fourth Commission d'Etudes of the C.C.I.F. is responsible, among other things, for specifying the quality of transmission for international telephone circuits with particular reference to the local network (i.e., speaking and listening conditions, subscribers' sets and local lines) aspects of the problems; it is also responsible for the work of the C.C.I.F. (formerly SFERT) Laboratory. The work of the 4th C.E. in January to June 1949 has already been reported<sup>1</sup> and it will suffice to say here that following the move of the SFERT Laboratory from Paris to Maison des Congrès, Geneva, late in 1948, it was decided:—

- (i) That the SFERT would be set up in the new laboratory and would be used solely for the measurement of Reference Equivalents (i.e., ratings by volume balancing).
- (ii) That a new equipment should be obtained to serve as a reference standard for ratings based on articulation measurements.
- (iii) That, in view of the fact that the SFERT would form only a part of the equipment, the name of the laboratory should be changed to the "C.C.I.F. Laboratory."

The SFERT<sup>2</sup> (*Système Fondamental Européen de Référence Téléphonique*), presented to the Laboratory in 1928 by the American Telephone and Telegraph Co., is a high-quality, stable reference system and has served the purpose of a reference standard for volume measurements satisfactorily for over 20 years. However, the move and the general re-equipment of the Laboratory, together with the increasing difficulty of maintaining the SFERT (much of which is obsolescent) and the decision of the 4th C.E. to pursue the question of rating by articulation, indicated that a good opportunity had arisen for providing a new reference standard.

Ratings based on articulation measurements known as A.E.N. (*Affaiblissement Equivalent pour la Netteté*) ratings have been specified in principle but the method

and various details of the technique require further study (which is in progress) before there can be any question of such ratings superseding Reference Equivalents.

A high-quality transmission reference system of modern design was offered to the Laboratory by the British Administration on loan for an indefinite period for use in further studies of the A.E.N. technique. The offer was accepted and the equipment, which is now installed and in operation in the C.C.I.F. Laboratory, has been named ARAEN (*Appareil de Référence pour la détermination des Affaiblissements Equivalents pour la Netteté*). In addition to the reference system proper (i.e., the transmission part of the apparatus) the complete ARAEN, as installed, includes much auxiliary equipment essential for A.E.N. measurements. The installation at Geneva was carried out in May and June 1949, and two sets of similar equipment are now in use at the Post Office Research Station, Dollis Hill.

The purpose of the present article is to describe the ARAEN itself; it is hoped to publish an account of the development of A.E.N. as a method of rating of transmission equipment as soon as sufficient information has been obtained to permit an exact specification of the technique.

### DESIGN PRINCIPLES OF THE REFERENCE SYSTEM

#### General.

The present techniques of articulation testing (and subjective transmission testing generally) are essentially comparative; they provide a result which expresses only the difference between the transmission characteristics of two or more systems. Thus the technique is obviously more useful if the comparisons are always made against one particular system, which is usually known as a "Reference System." From this aspect the main criterion of choice of a Reference System is stability of transmission characteristics. This leaves a wide choice of possible characteristics, but for various reasons the system will be most useful if it has the best possible transmission characteristics. A free air path remote from all

<sup>1</sup> For references see end of article.

reflections is envisaged as the ideal reference system from these points of view, i.e., stability and transmission quality. There is, however, a practical requirement which must also be satisfied if the system is to be used for articulation testing. The attenuation between the talker and listener must be variable, and it must be possible to increase the attenuation until the received speech signal is nearly inaudible. With an air-path system this could, in theory, be attempted by increasing the distance between the talker and the listener, but the difficulties of obtaining non-reverberant and non-reflecting conditions for the distances required are insurmountable, as are various other difficulties.

The use of variable acoustic noise as a means of simulating attenuation has also to be ruled out for practical difficulties and because it is not possible in this way to simulate non-reactive attenuation over a wide range of attenuations since the natural ear threshold will tend to be effective for low noise and the noise spectrum will provide the threshold for high noise conditions.

The concept of the air path is, however, basically attractive and the system developed by the Post Office has retained the concept, but realised it in a more practical form. The major part of the air path is replaced by an electro-acoustic system having exactly the same characteristics as that part of the air path which it replaces. To obtain a quantitative relationship the whole system is related to an air path of specific dimensions; the transmission characteristics between talker and listener afforded by the system, when used with a specified talking distance and overall gain, are equivalent to those existing when a talker speaks to a listener over a one-metre air path (an air path existing under reflectionless and non-reverberant conditions). This ideal condition is qualified by the fact that the Reference System uses monaural listening; it is therefore convenient to envisage monaural listening for the air path. The use of a system with monaural listening simplifies the equipment, and may perhaps be justified by the fact that it will be used to rate telephones which are themselves invariably monaural.

#### *Electric and Acoustic Requirements.*

The Reference System consists essentially of a microphone connected by a system of amplifiers and passive networks to a set of receivers. The overall performance of the equipment is specified by the requirement that the system must produce in the listener's ear a sound pressure which is an exact replica of that which would occur if the listener used the air path. This actually means that the system should not have a flat frequency response, because the obstructing effect of the human head alters the sound pressure in the entrance of the ear when an actual air path is used. Apart from this effect which must be reproduced in the system, the frequency response should be flat over the range of frequencies required for speech, say 80 to 6,000 c/s. The system should also be free from non-linear distortion, but this requirement presents little difficulty and it has not been found necessary to call for any precise specification of linearity.

To ensure that the system is stable and free from variation, the components and design must be carefully studied to ensure that it has the utmost reliability. The use of the reference system, though supervised by technical staff, is largely in the hands of non-technical operators; hence it should be as robust as possible and the controls should be the simplest that can be devised. For the electro-acoustic components the requirements of stability and robustness are probably best met by moving-coil receivers and microphones. With microphones and receivers high quality can only be obtained by some sacrifice of sensitivity; therefore the system needs several amplifiers whose gain stability can best be adequately ensured by sufficient negative feedback. All the components used in the system should be chosen carefully from the aspect of stability, special attention being paid to switch and relay contacts (particularly those in the main transmission path). Adequate facilities should be provided for testing all parts of the equipment, and some method of dividing the main transmission path is necessary both for testing and for fault location.

#### *Construction.*

The system should be constructed so that it is easily accessible both for general use and for maintenance. In this case the requirements are best satisfied by building the equipment on standard 19-in. panels mounted on apparatus racks, with the panel covers projecting through the racks (back-mounting covers). The layout of the components on the panels should be planned to provide the maximum accessibility; this applies particularly to all controls.

#### THE REFERENCE SYSTEM

A high-quality speech-transmission system, satisfying the requirements outlined above, has been designed in the Post Office Research Branch.

Fig. 1 shows the schematic arrangement of the Reference System consisting of three groups of equipment, the sending end comprising a microphone and amplifier system, the junction which consists of an attenuator and switching system (together with a filter, primarily for use with commercial systems under test) and finally the receiving end which consists of a further amplifier, equalisers and receivers.

#### *The Sending End.*

The design of this part of the system is dependent on two factors, the overall frequency response, and the level required at the output. The design objectives were a flat frequency response and a level of 1V when the microphone was talked into under specified conditions. The microphone (S.T.C. 4021E) used with the system does not have a perfectly flat frequency response, but all microphones exhibit the same characteristic, a gradual rise to a 5 db. peak at 500 c/s. When used with standard speaking conditions\* and a speaking distance of one foot, the microphone output is approximately -85 db. relative to 1V. There is some variation in this figure and therefore it is

\*A convenient speaking level standardised for articulation tests and specified acoustically.

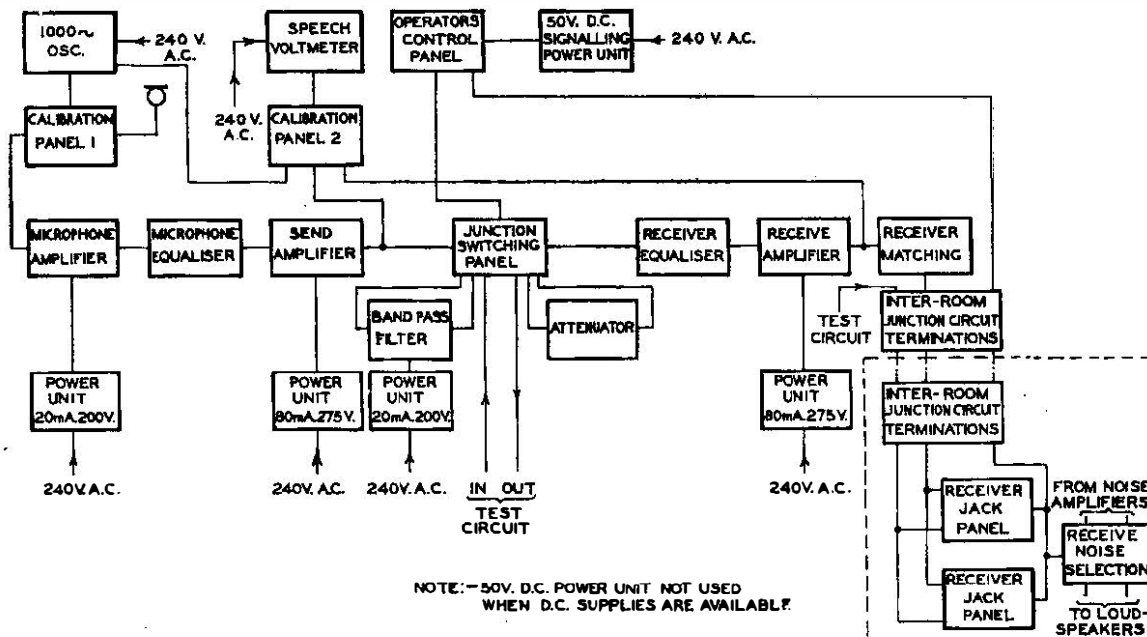

FIG. 1.—ARAEN; BLOCK SCHEMATIC DIAGRAM OF TRANSMISSION PATH.

necessary to provide a variable gain control at some point in the sending end.

The sending end consists of four main components; the microphone connected to the microphone amplifier, which is followed by the microphone equaliser and another amplifier known as the send amplifier. This arrangement was adopted to allow the equaliser to be placed at a point in the circuit where the level was not so low as to cause trouble from induced noise, or so high as to make the design of inductors uneconomical.

The microphone amplifier has two stages and operates at a fixed gain maintained constant by using 20 db. of negative feedback. Both current and voltage feedback are used, the proportions being arranged to make the output impedance 600 ohms. The design is straightforward except where special precautions have been taken to reduce the noise level at the output; these include the use of a special low-noise triode in the first stage, and special earthing precautions particularly on the input circuit. The gain of the amplifier is 47 db. and circuit noise level at the output is better than 85 db. below 1V.

The equaliser which follows the microphone amplifier is a constant impedance network having an insertion loss which is the inverse of the frequency response of an average microphone.

The send amplifier follows the equaliser and feeds directly into the junction; it has three stages, the final one being capable of handling 1.5W. The gain of this amplifier is also stabilised by both voltage and current feedback, proportioned to give an output impedance of 600 ohms. The gain can be varied by two controls; a calibrated potentiometer moving in 2 db. steps, which is placed between the input transformer and the grid of the first stage, and ganged variable resistances in the feedback paths moving in 0.2 db. steps. The amplifier is normally used with a

gain of 42 db., but this can be varied over a range of 20 to 64 db. in 0.2 db. steps by the two controls mentioned previously.

In articulation testing the talker is required to speak at a fixed level and thus some instrument must be provided to indicate the talking level. The characteristics of such instruments are specified by the C.C.I.F.,<sup>3</sup> and the instrument (known as a speech voltmeter) used with this system complies with the specification except in respect of one of the ballistic properties of the indicating instrument. The speech voltmeter is connected across the output of the send amplifier which is the point where a level of 1V should exist when the talker is speaking. A 1,000 c/s oscillator is provided with the speech voltmeter for calibration purposes; this oscillator also has a low-level output (80 db. below 1V) which can be connected in place of the microphone for checking the overall gain of the system. The speech voltmeter can be used as a level-measuring set for these measurements. The various oscillator and speech voltmeter connections are made by rotary switches.

The overall gain of the sending end depends on the sensitivity of the microphone. A mean figure is calculated for each microphone and the gain of the send amplifier is adjusted accordingly. Between microphones the variation of mean sensitivity is of the order of 1 db.

#### The Junction.

The term junction covers the variable non-reactive attenuator and any filters or other equipment connected between the sending and receiving ends. In the Post Office system these are connected to a switching panel which allows the attenuator to be used by both the Reference System and by commercial systems which are being tested. A 300-3,400 c/s band-pass filter is provided with the equipment and

can be included in the junction if required. The attenuator (and filter) are changed from one circuit to another by relays mounted on a switching panel controlled by a key and selector switches placed near the operator at the talking position. The switching panel has U-link break points for inserting special equipment, and the switching arrangements have been designed so that the combination of components (i.e., attenuator, filter, etc.) can be changed when the junction is switched from one circuit to another. The switching is designed to enable two commercial circuits to be compared with the Reference System.

The attenuator panel contains two high-grade H-type 600 ohms variable attenuators, controlled by rotary switches. One attenuator covers the range 0-10 db. in 1 db. steps; the other 0-100 db. in 10 db. steps.

The band-pass filter included in the equipment has been specially designed to have an insertion loss/frequency characteristic of a typical carrier system. (The band 300-3,400 is in accordance with C.C.I.F. recommendations.)<sup>4</sup> The filter consists of separate low- and high-pass sections with an amplifier between

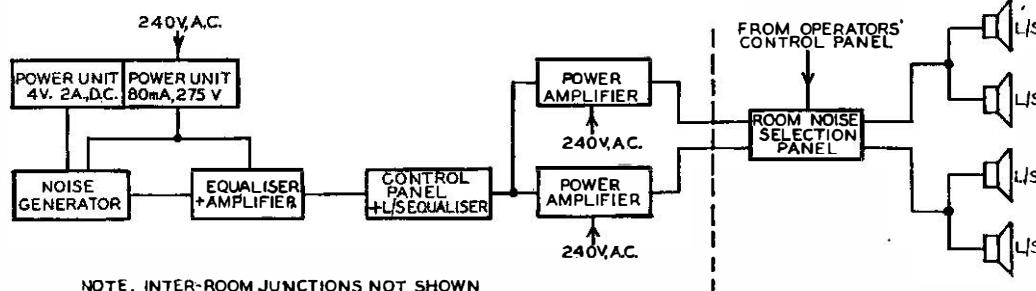

NOTE. INTER-ROOM JUNCTIONS NOT SHOWN

FIG. 2.—ARAEN; BLOCK SCHEMATIC DIAGRAM OF NOISE GENERATION EQUIPMENT.

them. The gain of the amplifier is adjusted so that the overall insertion loss in the pass band is zero.

#### Receiving End.

The most important components are the high-quality moving-coil receivers (S.T.C. 4026A). The frequency response of these is not quite flat, consequently some equalisation is necessary. The overall response of the system also includes the obstruction effect of the human head and it is necessary to introduce a weighting network into the receiving end to allow for this. In practice it was found easier to design one network which both compensated for the response of the receivers and introduced the obstruction effect.

To enable four listeners to listen simultaneously, four receivers are connected in series. This method of connection was chosen as the probability of a receiver circuit fault affecting all listeners is much greater. (The usual receiver circuit faults are high-resistance cords or plugs.) To compensate for the loss of the equaliser network it is necessary to introduce some gain into the receiving end. The requirements call for an amplifier with less gain than the send amplifier but capable of handling the same maximum output level. To avoid duplicating designs, a send amplifier with a different ratio input transformer is used, giving a normal gain which is 20 db. lower.

The receiving end is arranged so that the output of the junction feeds into the receiver equaliser, then through the receive amplifier to a matching transformer and then to the receivers (total impedance of four receivers, 88 ohms resistive). The listeners sit in a sound-proof room remote from the sending end and their equipment is connected to the main equipment by a system of junction cables. The output of the matching transformer is fed to jack-panels at the listening positions, where the receivers are plugged in. All four receivers must obviously be in circuit when the system is in use, irrespective of the number of listeners.

#### EQUIPMENT ASSOCIATED WITH THE REFERENCE SYSTEM Noise Generation and Measuring Equipment.

This equipment provides room noise at the operators' listening position, produced by loudspeakers suspended from the ceiling of the sound-proof room, and facilities for measurement of the level of this noise.

Fig. 2 shows, in block schematic form, the noise generation equipment which consists of a continuous

spectrum noise generator, weighting networks to give the noise the required spectrum and power amplifiers which feed the loudspeakers. The continuous spectrum noise is obtained by amplifying the fluctuation noise produced by a gas-filled triode. This source is eminently suitable as it produces a comparatively high level of noise with a flat spectrum (i.e., the energy per c/s is constant). The noise is then fed through a weighting network to give it the spectrum described by Hoth<sup>5</sup> as that of the average room noise occurring in subscribers' premises. To compensate for the loss introduced the weighting network is followed by another amplifier.

The output of the weighting network amplifier is fed through an equaliser, which compensates for the characteristics of the loudspeakers and listening room, then through variable attenuators to the power amplifiers which supply the loudspeakers. The system is thus designed so that the overall frequency response of the equaliser, power amplifiers, and loudspeakers is flat.

To measure the noise level produced by the loudspeakers in the listening room, a sound-level meter is provided on the racks adjacent to the room-noise level controls. This meter consists of a high-quality moving-coil microphone (S.T.C. 4021E) in the listening room, and a microphone amplifier, weighting net-

work and speech voltmeter on the rack. The complete chain of components complies with the American Standard for sound-level meters.<sup>6</sup> A calibrating oscillator and switching arrangements are included with the system to provide facilities for checking the gain of the microphone amplifier and the sensitivity of the speech voltmeter. The switching arrangements also allow the circuit between the microphone and the microphone amplifier to be run over a cable normally used for an intercommunication circuit.

#### *Intercommunication Equipment.*

When carrying out articulation tests, the operator at the talking position has to pass instructions to the others at the listening position and they have to indicate when they are ready to start. A simple loudspeaking telephone system is installed with the Reference System to provide these facilities. Facilities are provided for holding a conversation between the talking and listening positions, and between the noise-generation equipment racks and the listening position (this facility is useful when adjusting the noise level).

The equipment provided at each position consists of a 3½-in. loudspeaker mounted on a panel together with a change-over key and a volume control. With the key in the normal position the loudspeaker is connected to the output of a three-stage amplifier mounted on the noise equipment racks. When the key is operated the loudspeaker is used as a microphone and is connected to the input of the amplifier feeding the loudspeaker at the listening position. The loudspeaker on the noise equipment racks, though having its own amplifier, is effectively in parallel with that at the talking position. Switching is provided to cut it in and out as required.

#### *Transmission Measuring Equipment.*

The performance of the electrical elements of the system can best be checked by pure-tone transmission measurements. To facilitate these a wheeled rack containing suitable measuring equipment is provided with the system. The equipment consists of a variable-frequency RC oscillator (30 to 30,000 c/s), a level-measuring set and a switching panel which enables a variety of measurements to be made.

The oscillator is essentially a wide-band three-stage amplifier with overall positive and negative feedback paths taken from the cathode of the third stage. The positive path contains the frequency-selective network, which is of the series-parallel resistance-capacitance type. In order to obtain low harmonic content and constancy of output level at different frequencies, amplitude limitation is effected by a number of tungsten filament lamps in circuit with the frequency-selecting network.

The controls of the selective network move in discrete steps and are arranged in decades to cover the range 30 to 3,000 c/s in 1 c/s steps and 3,000 c/s to 30,000 c/s in 10 c/s steps. A continuously variable control, which sweeps over the smallest steps of the decade is also provided. The oscillator is fitted with a temperature-controlled oven for the frequency-selective networks and when this is in use the frequency of oscillation is stable to within 0.04 per cent. (The oven takes roughly 15 minutes to reach

its stable temperature.) A variable non-reactive attenuator is provided in the output giving 1 db. steps over a range of 60 db.

The level-measuring set used with this equipment is the standard Tester RP790. The third panel, which contains the switching arrangements, provides facilities for quickly making overall transmission measurements on the Reference System, measuring the insertion loss of networks (or gain of amplifiers), the gain of microphone amplifiers and various transmission measurements on local telephone circuits. This last facility is useful for checking the performance of the local telephone circuits, which are compared with the Reference System.

The whole equipment is mounted on a standard 6 ft. 6 in. rack (which is fitted with a wheeled chassis).

#### *Acoustic Test Gear.*

The electro-acoustic elements have been chosen for stability but it cannot be assumed that they will not vary during the life of the ARAEN, particularly as a life of at least 15 years has been envisaged. Consequently a set of equipment for checking the performance of both microphone and receivers has been provided.

The check need not necessarily be an absolute calibration and some more convenient method can be used. The method must, of course, be sensitive to any change in the absolute response of the microphone or receiver. These principles have been followed in the design of the test gear, where the microphones are calibrated on a coupler device and the receivers on an artificial ear. The sound pressures inside the coupler and the artificial ear are measured by a probe-tube microphone which must itself be calibrated on some absolute standard of sound pressure. The absolute standard used with this equipment is a stationary-wave tube and Rayleigh disk.

The acoustic equipment is mounted on three racks with a table for the Rayleigh disk apparatus and the stationary-wave tube. The plan of the equipment in Fig. 3 shows the arrangement of the racks and the table for the stationary-wave tube and Rayleigh disk apparatus. A further table is placed between the racks for the convenience of the operator when recording results.

The Rayleigh disk equipment<sup>7</sup> is used solely for measuring the sensitivity of the probe-tube microphones. These consist of a high-quality moving-coil microphone mounted in a heavy metal case, with a hypodermic tube (0.03 in. internal diameter) which forms the path between the microphone diaphragm and the sound field. The particular advantage of this type of microphone is that the tip of the probe causes only a negligible amount of disturbance when inserted in any sound field. The stationary-wave tube used with the Rayleigh disk equipment is a rigid-walled metal tube closed at one end with a moving-coil receiver, and at the other with a plate containing a small opening which will allow the insertion of the microphone probe tube.

If a voltage of suitable frequency is applied to the receiver a stationary sound wave is produced in the tube with a pressure maximum at the plate where the probe tube is inserted and a velocity maximum at the

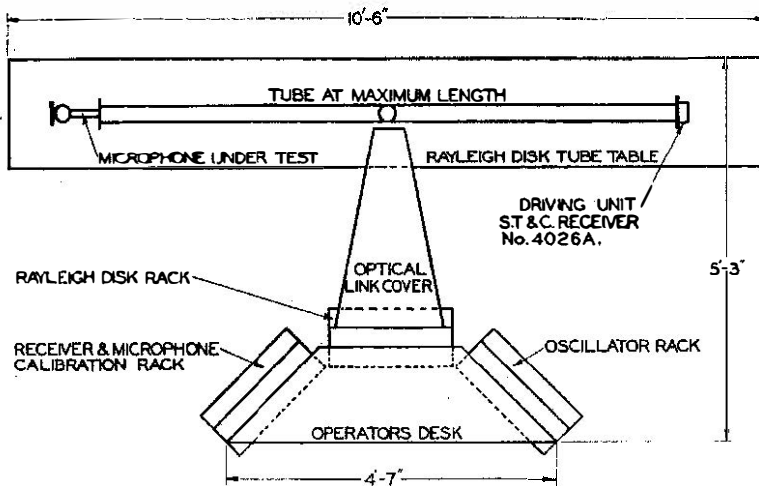

FIG. 3.—PLAN OF MICROPHONE AND RECEIVER CALIBRATION EQUIPMENT.

centre of the tube. The Rayleigh disk is suspended at the centre of the tube with its plane at  $45^\circ$  to the axis. When a sound wave exists in the tube, the disk rotates through a small angle which is dependent on the air-particle velocity, and this is in turn related to the sound pressure at the end of the tube. By a lamp and mirror system the angular rotation is displayed on a screen mounted on the centre rack of the equipment. From the angular displacement of the Rayleigh disk it is possible to calculate the sound pressure applied to the probe-tube microphone. The E.M.F. produced by the microphone can be compared with a known voltage of the same frequency by means of an amplifier and voltmeter system. The known voltage is obtained from an accurate potential divider which is fed from the oscillator supplying the receiver (an oscillator similar to that used in the transmission measuring equipment). The output of the oscillator is itself measured with a thermo-couple instrument which can readily be calibrated against a D.C. sub-standard instrument. The voltmeter associated with the amplifier system (actually the amplifiers used in the Reference System sending end) is a Tester RP790 which in this case is only used as an indicator of equal values. All these operations can be made in a simple manner with the switching arrangements built into the equipment.

To calibrate the microphones used with the Reference System a closed coupler device is employed. This is a small open cylinder with a high-quality receiver (S.T.C. 4026A) clamped on one end as a source of sound, and the microphone under test clamped on the other. (To do this the grille of the microphone has to be removed.) The tip of the probe-tube microphone is inserted through the wall of the coupler and placed in an accurately defined position close to the centre of the diaphragm of the microphone under test. The measurement of the sensitivity of the microphone is made by comparing, at various frequencies, the output of the probe-tube and the test microphones. The comparison is carried out by adjusting an attenuator in the test microphone circuit until both give the same deflection on the Tester RP790. The attenuator readings then

represent the difference in sensitivity of the two microphones and their associated circuits, consequently the calibration of the Reference System microphone when used under the particular conditions imposed by the coupler, can be derived from the calibration of the probe-tube microphone. A calibration under the conditions of the coupler though not the conditions of use is sufficient to check that the microphone has not altered in sensitivity at any frequency.

Receivers are calibrated on the artificial ear, again with the use of the probe-tube microphone. The artificial ear<sup>8</sup> is used to close the receiver with an acoustical impedance which has been designed to lie within the range of impedances observed on male ears. The receiver is placed centrally on the artificial ear and sealed acoustically with a smear of vaseline.

A known voltage is applied to the receiver terminals and the sound pressure developed in the artificial-ear cavity is measured by the probe-tube microphone inserted at a suitable point. The output of the probe-tube microphone is measured in the same way as when it was itself being calibrated. This enables the response of the receiver on the artificial ear to be derived from the probe-tube microphone characteristic. The response obtained depends on the position of the probe-tube microphone and for these measurements the entrance of the probe-tube is placed at the bottom of the artificial-ear cavity.

#### INSTALLATION OF THE EQUIPMENT AT THE C.C.I.F. LABORATORY

Three Reference Systems and two sets of associated equipment were constructed at Dollis Hill, and one of these systems and one set of associated equipment were sent to the C.C.I.F. Laboratory at Geneva.

The equipment was erected in three groups, consisting of the Reference System, the noise and intercommunication equipment, and the acoustic test gear. The first two groups were placed in the room which also contains the old SFERT system, whilst the acoustic test gear was placed in a separate room. The major part of the Reference System is mounted on two standard 6 ft. 6 in. racks, which are placed immediately behind the table used for the talking position (see Fig. 4). The talker sits at this table which contains the stands for the microphone of the Reference System and for handsets of any telephone sets under test; a steel cabinet containing various controls for the system together with a loudspeaker panel for the intercommunication system is mounted beside the operator. The remainder of the Reference System is located at the listening position, which is in a sound-proof room, situated at some distance from the talking position.

Connections between the Reference System and the listening position are made by a number of single-pair cables which are terminated on U-link sockets close to the talking and listening positions. The circuits are



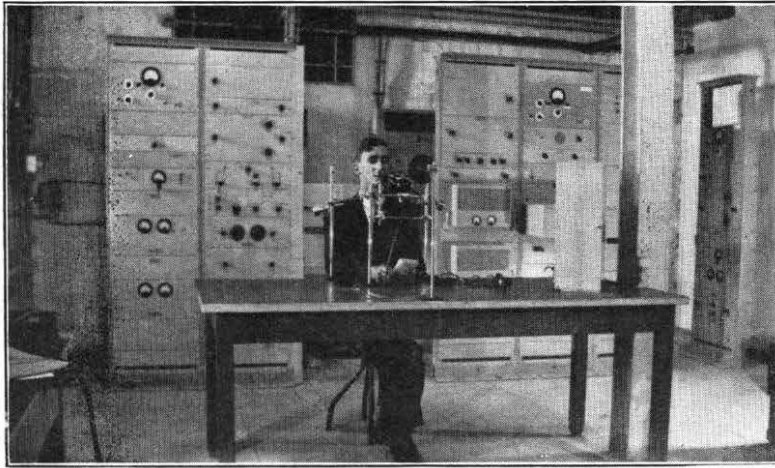

FIG. 4.—THE TALKER'S TABLE AND ADJACENT REFERENCE SYSTEM RACKS.

then wired through a U-link break point to their appropriate apparatus. The local wiring is carried out in special cable with an insulated, braided copper screen.

A number of circuits between the talking and listening positions is also required for apparatus which is being tested against the Reference System. The C.C.I.F. laboratory staff, therefore, installed a 25-pair cable at the same time as the circuits for the Reference System. This cable, which has individually screened pairs, is terminated on the same U-link panels as the others. All these cables are run at ceiling height on light racking which was built in sections at Dollis Hill and then assembled as required on site.

The noise generation and intercommunication equipment is mounted on three racks which are placed close to the talking position. Connections between these racks and the listening position are made in the same way as those for the Reference System.

The acoustic test gear does not require frequent use and has no external connections except one to the A.C. mains supply. As the room containing the Reference System was already full, the test gear was placed in a separate room. The equipment consists of three racks, and a table to contain the Rayleigh disk apparatus. This needs an extremely rigid table of rather unusual proportions and one was made specially from welded stainless steel tube and black plastic sheet. This equipment was more difficult to

erect than the other as both the racks and the table had to be fixed accurately in position.

The whole work of installation was carried out without any major difficulties arising, though the structure of the building caused some minor problems in the installation which were dealt with satisfactorily by the Post Office staff carrying out the work. The staff of the C.C.I.F. laboratory provided valuable assistance both in making preparations before the arrival of the equipment and in assisting the Post Office staff during the installation.

#### Conclusion.

The ARAEN installed at the C.C.I.F. laboratory is at present (January 1950) in use for training C.C.I.F.

laboratory staff on articulation testing in preparation for the 8th Series of Tests of the laboratory which deals with the development of the A.E.N. method of rating. A number of questions on the technique of use can only be finally decided at the stage when the 4th C.E. specifies the complete details of the A.E.N. method; the 8th Series of Tests is itself the main means of providing data on which these decisions can be based. These decisions are concerned with such points as the use of room noise at the receiving end and the precise method of specifying the talking level; they will not involve more than very slight changes in the ARAEN itself.

#### REFERENCES

- <sup>1</sup> "C.C.I.F. Meetings May and July, 1949," *P.O.E.E.J.*, 1949, Vol. 42, p. 168.
- <sup>2</sup> Martin, W. H., and Gray, C. H. G. "Master Reference System for Telephone Transmission," *B.S.T.J.*, 1929, Vol. 8, p. 536.
- <sup>3</sup> C.C.I.F. White Book (1934), Tome IV, p. 263.
- <sup>4</sup> C.C.I.F. "Programme Général d'Interconnexion Téléphonique en Europe (1947-1952)," p. 26.
- <sup>5</sup> Hoth, D. F. "Room Noise Spectra at Subscribers' Telephone Locations," *Journal of Acoustical Society of America*, 1941, Vol. 12, p. 499.
- <sup>6</sup> American Standards Association. "Sound Level Meters for Measurement of Noise and Other Sounds," Standard No. Z24.3—1944.
- <sup>7</sup> West, W. "Acoustical Engineering" (Pitman, 1932), p. 138.
- <sup>8</sup> Medical Research Council, Special Report Series, No. 261. "Hearing Aids and Audiometers" (H.M. Stationery Office, 1947), p. 37.

## Book Review

"Numerical Exercises in Electrical Wiring. W. S. Ibbetson. E. & F. N. Spon, Ltd. 87 pp. 6s.

A companion book to the author's *Electric Wiring Theory and Practice*. In the earlier editions of the latter work, exercises were included, but these have been omitted from the later editions owing to space limitations. The present book fills the gap. The arrangement and numbering of chapters follow that of the parent book and a total of over 400 numerical exercises has been collected from various sources, such as City & Guilds, Ministry of Transport and Institution of Marine

Engineers' examinations. The exercises are essentially practical in character, as would be expected from the nature of the subject, and the student wiremen cannot but profit by working the examples. An introductory chapter of exercises on general mathematical principles should reassure the non-mathematically inclined that only elementary mathematics is necessary for the solution of the wiring problems presented. General data and trigonometrical tables are included and also answers to the problems.

W. T. G.

# Improved Method of Cable Buoy Recovery

U.D.C. 621.315.29

IT may be of interest to readers to learn of a nautical improvement in cable operations which has been satisfactorily developed in H.M.T.S. *Monarch* for the recovery of buoys at sea, in deep water (500 to 3,000 fathoms).

The method in the past has been to approach the buoy to within a distance of about half a cable (100 yards) and then lower a boat which pulled to the buoy, taking with it the end of a  $3 \times 3$  wire rope. This was attached to the buoy moorings (a stray end of which was led to the upper part of the buoy for the purpose). The slip-hook attachment holding the moorings to the buoy was then "knocked up" with a hammer and the buoy was released from the moorings which then led directly on board the cable ship via the  $3 \times 3$  rope previously mentioned. The

overcomes these troubles and has been most successfully used during the past two years in all weather and sea conditions. Briefly it consists of steaming right up alongside the buoy and getting hold of the "tail" with a light grapnel and line from the deck of the ship. This tail is the free end of the buoy moorings extended to a length of about 30 fathoms and fitted with cork floats and metal "pellet" floats, which is left free to float out from the buoy when it is originally streamed, and serves, additionally, as a current direction indicator when approaching the buoy to recover it.

Having recovered the tail with the light grapnel and line it is picked up to the deck and shackled to a heavy wire rope led over specially constructed lifting leads fitted to the bulwarks, and then to the

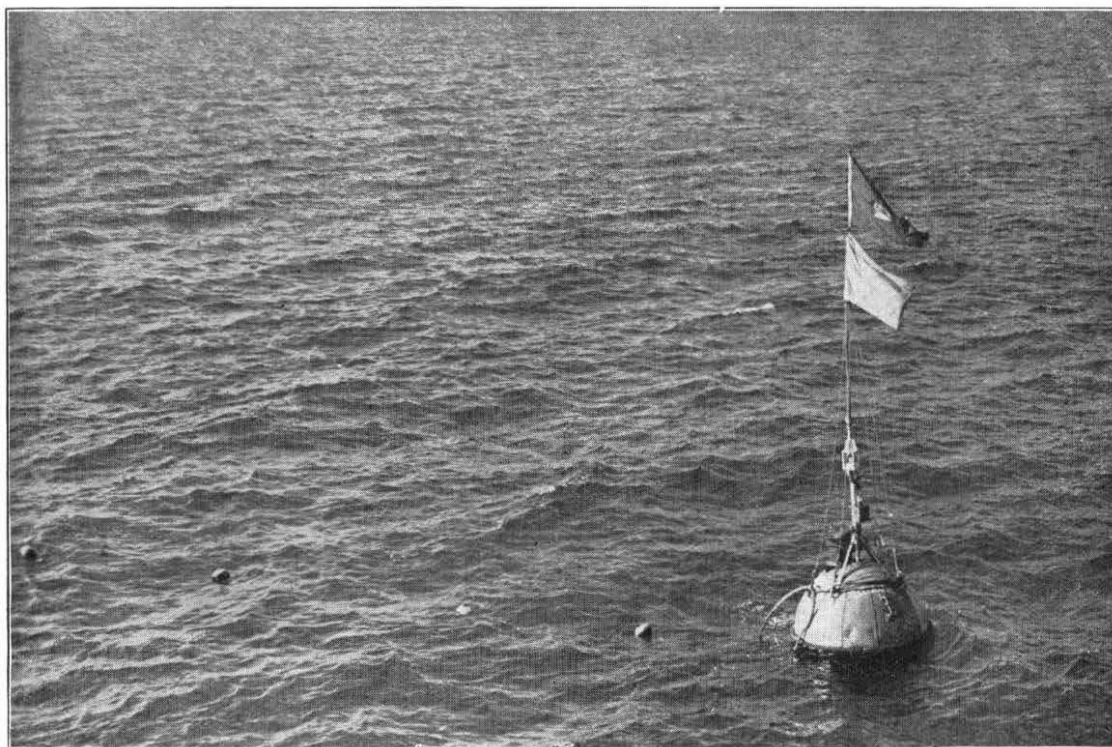

FIG. 1.—CABLE BUOY WITH "TAIL." CURRENT DIRECTION OPPOSED TO WIND DIRECTION AS SHOWN BY FLAGS.

boat then pulled back to the ship towing the cable buoy, and boat and buoy were hoisted on board. The moorings were picked up in the usual manner over the bow sheaves.

This method whilst satisfactory to some extent had many disadvantages, not the least of which were the dangers to the boats' crews encountered in lowering and hoisting boats in bad weather. This factor alone frequently made it impossible to proceed with cable operations until the weather and sea conditions eased, and much time has been lost on this account in the past.

The improved method developed in *Monarch*

forward capstan. Upon heaving away on the capstan the weight of the moorings is taken directly and the buoy comes up on them to deck level. It is then all clear of the seas and can be got at in comparative comfort to shackle on the  $6 \times 3$  rope which has been led from the cable gear to the bow sheaves and then back outboard to the buoy-lifting sheaves.

When this has been shackled up it is slipped from the buoy and on picking up on the cable gear the moorings are transferred to the bow sheaves and picked up and the buoy, which is left at the buoy-lifting sheave, is unrigged and taken inboard.

J. P. F. B.

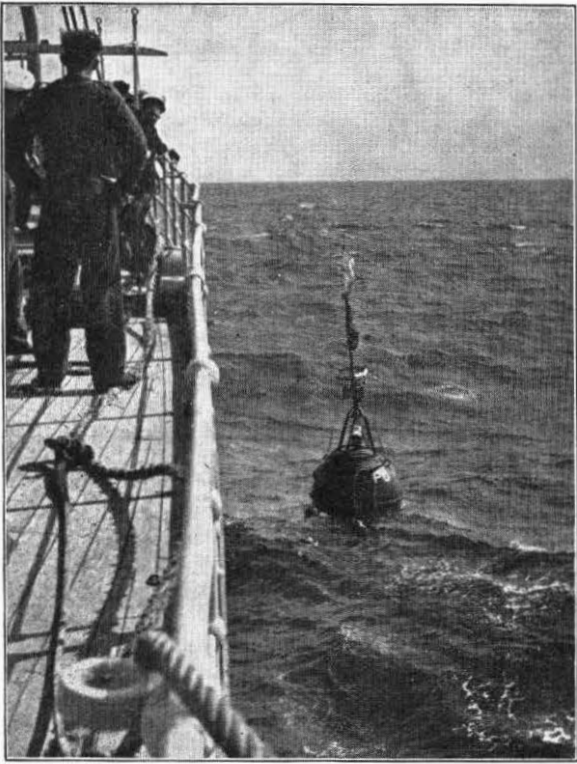

FIG. 2.—APPROACHING BUOY BEFORE RECOVERY

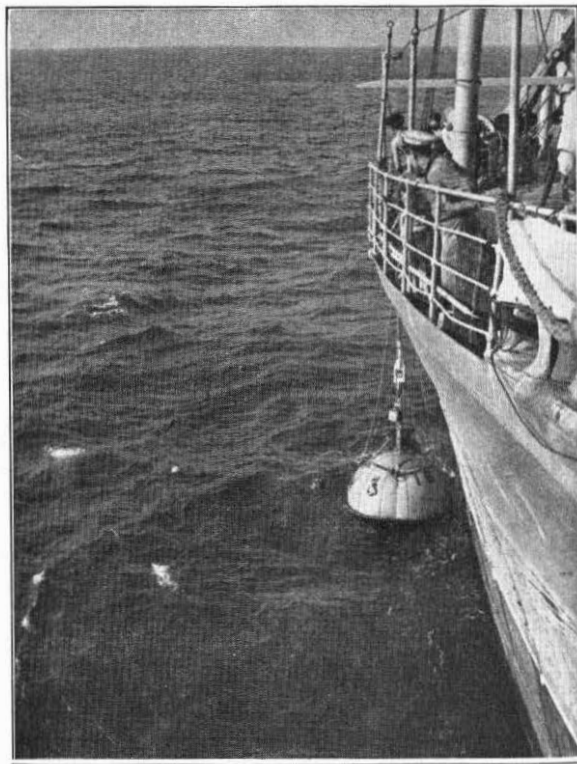

FIG. 3.—VIEW, LOOKING AFT, OF BUOY COMING IN ALONGSIDE SHIP AND SEAMEN HOOKING "TAIL" WITH GRAPNELS.



FIG. 4.—SEAMAN SHACKLING 6 X 3 ROPE FROM BOW SHEAVE BEFORE MOORINGS ARE SLIPPED FROM BUOY AT SIDE SHEAVE.

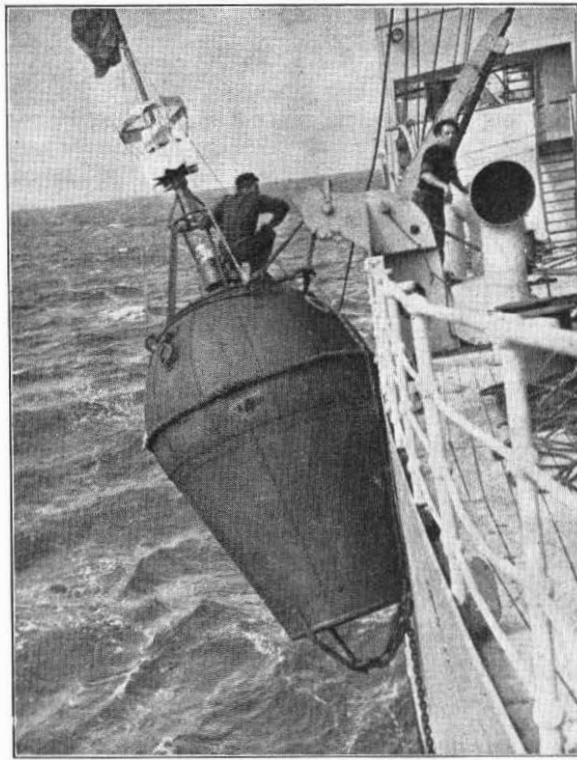

FIG. 5.—BUOY HOISTED TO DECK LEVEL ON SPECIAL SHEAVE.

# A Survey of Modern Radio Valves

K. D. BOMFORD, M.Sc., A.M.I.E.E.,  
and A. H. F. HUNT

## Part 4.—Transmitting Valves for use up to 30 Mc/s.

U.D.C. 621.385

The principles of operation of transmitting valves for use up to about 30 Mc/s are generally similar to those applicable to the corresponding receiving valves. The discussion in this article, therefore, is mainly confined to questions of design and construction, with particular reference to the materials used for envelopes and electrodes and the means adopted for disposal of heat liberated during valve operation.

### *Introduction.*

SOME of the basic phenomena of the primary and secondary emission of electrons, and of electrons in transit have been outlined in Part 2 of this series,<sup>1</sup> in so far as they apply to the behaviour of thermionic valves; and these properties affect the design of high-power transmitting valves just as much as they do that of the receiving valves already considered,<sup>2</sup> although in places the emphasis differs appreciably. This difference of emphasis arises because many of the problems in designing the larger valves are different from those encountered with receiving valves which, in turn, is due to the use of high anode voltages and to the need to dissipate large quantities of heat.

The need to avoid parasitic oscillations and to reduce stray and inherent inductance and capacitance, and considerations of space and general neatness militate against the use of large numbers of valves in parallel for handling high powers. Valves have, therefore, been developed that are individually capable of handling powers of a hundred kilowatts or more.

The development of such large valves for use on frequencies below, say, 30 Mc/s might appear to have been slow when compared with the many different ranges of receiving valves that have been produced. This is because there are many difficulties associated with high-power operation which have no counterpart at low powers, and because high-power valves are expensive and are produced in small numbers so that there is a natural reluctance to depart from a proven design.

The literature of transmitting valves is largely concerned with the need to provide for and dispose of the large quantities of heat liberated at the electrodes, mainly the anode; and the size of a transmitting valve is normally referred to in terms of the rate at which the valve can dissipate heat from the anode, i.e. its "anode dissipation." This is because there is an upper limit to the efficiency with which a valve can convert the D.C. anode supply into radio frequency power, of the order of 70 per cent., and the power handling capacity is usually limited by the anode dissipation. In the smaller valves of this class the anode, and of course the other electrodes, are enclosed in an envelope and the heat liberated must be dissipated almost entirely by radiation. In larger valves the anode forms part of the envelope and is fitted either with cooling fins through which air is forcibly circulated or with a water-jacket connected

to a circulation system. Radiation of heat from the anode is then negligible but from other electrodes remains of primary importance. This subject will, however, be considered in more detail when describing different types of valve.

Transmitting valves for the frequencies concerned in this article are made in the form of triodes, tetrodes, i.e. screen-grid valves, and pentodes, but the first-named include the great majority of valves. The principles of operation are generally identical with those of the corresponding receiving valves except that in transmitting valves the grid must be driven well positive during part of each cycle in order that the peak anode current may approach the maximum available emission from the filament, resulting in the flow of appreciable grid current. To avoid repetition, therefore, it is proposed to discuss only those matters that are peculiar to transmitting valves, questions largely of design and construction.

### CONSTRUCTIONAL FEATURES

#### *Filament Material.*

In high-power valves the large potential difference between the anode and cathode gives rise to much higher positive-ion arrival velocities than an oxide-coated cathode can withstand, and the more robust but less efficient thoriated-tungsten and pure tungsten filament cathodes are therefore used. In recent years the achievement and maintenance under operating conditions of a higher degree of vacuum than has hitherto been possible has led to a rise in the permissible D.C. anode voltage for valves using thoriated-tungsten filaments. Nevertheless, it is still necessary to use pure tungsten for the filament material when anode supply voltages much above 10,000 volts are used. Relating filament material to methods of cooling it usually happens that thoriated-tungsten is used in radiation-cooled valves while pure tungsten is used in valves of such high power that forced cooling is needed.

#### *Glass Envelopes.*

The properties desirable in glass used for the envelopes of transmitting valves are high insulation resistance, low radio-frequency power factor, high resistance to thermal shock, high thermal transparency, low thermal expansion and, last but not least, high softening temperature. Common soft glass, i.e. lead-soda or lead-soda-potash glass, is relatively cheap and has most of these properties, although its softening temperature is only 850°K and its thermal expansion is comparatively high. Such a glass is quite suitable for lower power valves with

<sup>1</sup> P.O.E.E.J., Vol. 42, p. 118.

<sup>2</sup> P.O.E.E.J., Vol. 42, p. 201.

small leading-through wires for the electrodes. The permissible heat dissipation can be increased by the use of either a larger bulb or a harder glass such as pyrex, or borosilicate, with a higher softening point than soda-glass, i.e. about 980°K. Unfortunately, hard glasses have the disadvantage of fairly high annealing temperatures and are more difficult to manipulate; in addition, they are not so transparent to radiant heat as soda-glass. The power factor of glass increases with temperature and in very strong radio-frequency fields the dielectric loss may cause sufficient local heating at frequencies of the order of 30 Mc/s to soften the envelope.

The risk of envelope softening places a limit on the permissible anode temperature in glass valves and restricts the power dissipation by radiation to between 25 and 60 watts per sq. in. of anode surface, depending upon the anode material used. An attempt to increase the power dissipation by an arbitrary increase in anode dimensions leads to difficulties in the design of the filament, which becomes unnecessarily long for the emission requirements. It is therefore unusual for glass envelope valves to have power ratings exceeding about 1.0 kW.

#### *Silica Envelopes.*

An increase in permissible power dissipation to about 5 kW, without forced cooling, is obtained by using silica envelopes in place of glass. The much higher softening temperature of the envelope, in the region of 2,000°K, allows the working temperature of the anode to be raised, and greater powers to be dissipated for the same bulb size; it also allows the valve to be pumped and de-gassed at very high temperatures, resulting in more complete elimination of adsorbed gases and a higher degree of vacuum. One effect of the improved vacuum is to reduce positive-ion bombardment of the filament; this allows a thoriated-tungsten filament to be used when the anode voltage is higher than is permissible with the same type of filament in a glass envelope valve.

For many years, however, a disadvantage of silica valves was the difficulty of producing seals<sup>3</sup> that could withstand the high temperatures due to the relatively large inter-electrode R.F. currents that occur in operation at high frequencies. Reliable direct metal-to-silica joints were made only with difficulty and the earlier silica valves used soft glass seals.

In recent valves this temperature limitation has been overcome by using a seal of tungsten-coated molybdenum with hard glass between the metal and silica and the maximum frequency of operation has been raised to between 20 and 50 Mc/s.

#### *Glass-to-Metal Seals.*

A great advance in the design of high-power valves was made when it became possible to dissipate heat from the anode by bringing a cooling medium into direct contact with it. This can only be achieved conveniently by making the metal anode form part

<sup>3</sup> The junction between the metal of the leading-through connections or the electrodes, and the glass or silica envelope is called a "seal."

of the envelope, and requires a large metal-to-glass seal. In the Housekeeper seal, which was first introduced in 1922, the difficulty of the difference in the coefficients of expansion of glass and metal is overcome by a process that involves machining the end of a tubular copper anode to a fine edge and fusing the glass envelope to the copper, using borax as a flux. The thin copper edge can be made sufficiently flexible to withstand the differential expansion stresses without sacrificing the strength needed to withstand the atmospheric pressure, which may amount to several hundred pounds in the largest valves. The temperature of the Housekeeper type of seal should not exceed about 470°K under working conditions.

An alternative seal has been developed using an alloy ring with a thermal expansion coefficient more closely matching that of the glass. An intermediate alloy ring of copper-plated nickel-iron is sealed to the glass, using borax as a flux, and brazed to the copper anode, and it is interesting to note that the latter joint gave more difficulty in the initial development. The copper plating on the alloy increases adhesion to the glass and lowers the resistance to high-frequency eddy currents which would otherwise overheat the ring. Seals of both types have been made up to rather more than 5 in. diameter.

Protection from strong electric fields and excessive dielectric stresses set up by the sharp metal edge is provided by internal and external guard rings, the external guard ring often serving as an air blast pipe for cooling the seal.

#### *Electrode Materials.*

The materials used for the anodes in transmitting valves depend on whether the valves are radiation-cooled or forced-cooled, i.e. whether the anode is inside the envelope, or forms part of it. In radiation-cooled valves the anodes are commonly made of tantalum or molybdenum as these metals have the advantage of being relatively free from occluded gases. Their radiating properties are often improved by sand blasting the surface of the anode or by providing cooling fins inside the valve. Certain of these metals will, when very hot, absorb gases in sufficient quantity to make them extremely useful for maintaining a high degree of vacuum. This "clean-up" capability is specially desirable because getters such as magnesium and barium cannot be used in transmitting valves on account of their liability to volatilise at the high temperatures involved. Carbon anodes are also used in some cases.

The vapour pressure of the anode material affects the maximum temperature that can be permitted in operation or during pumping, because of the possibility of metal becoming deposited on the insulating surfaces. In this respect tungsten and tantalum are very satisfactory, but nickel, which is otherwise a very suitable material, has a high vapour pressure and its use is therefore restricted to valves of low and moderate ratings. In radiation-cooled valves the anode surface is commonly coated with amorphous carbon to improve the thermal emissivity.

Where the anode forms part of the valve envelope heat is removed from it by conduction to the cooling

fins or the cooling water, and the working temperature is low. In such valves good thermal conductivity is of great importance and the anode material should be suitable for sealing to the glass portion of the envelope; for these reasons copper is used almost exclusively.

The grid material also must be capable of withstanding high operating temperatures, partly because there is appreciable grid current, and partly because of the proximity of the heated filament and the fact that the surrounding hot anode surface impedes heat radiation from the grid. Tungsten, tantalum or molybdenum are commonly used and the surface may be carbonised to improve the heat radiation and also to reduce grid secondary emission. Grid structures using these metals do not distort at high temperatures, while all three are sufficiently ductile for drawing into fine wire for the grid winding.

#### VALVE TYPES

##### *Radiation-cooled Valves.*

As an illustration of modern radiation-cooled valve construction, Fig. 1 shows a 1.5-kW valve in a recently

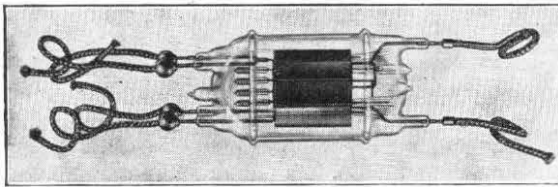

FIG. 1.—1.5-kW SILICA ENVELOPE VALVE.

introduced series of silica triodes for use up to at least 30 Mc/s. Two leads each are provided for the anode and grid to assist in keeping the temperature of the seals low and it will also be noticed that the envelope is shaped so that the seals are spaced well away from the hot anode.

It is worth noting that the development of valves for this range has been stimulated by the widespread adoption of dielectric and induction heating in industrial processes, for which the conditions of operation, being intermittent and not subject to the same rigid control, are generally more severe than in radio transmitters.

##### *Water-Cooled Valves.*

Liquid cooling is the most effective means of transferring large quantities of heat from the anode; and if certain precautions are observed water forms a very convenient cooling fluid and enables anode dissipations exceeding 1 kW per sq. in. of anode surface to be attained. The velocity of the water must be sufficient to ensure turbulence so that any steam bubbles formed do not adhere to the outside of the anode and allow local overheating, and the space between the anode and water jacket may be constricted to increase the water velocity and reduce the thickness of the stagnant layer of water that tends to form at the surface of the anode wall. The rate of flow required is directly proportional to the power dissipation for a given temperature rise. The heat transfer from anode to water is more efficient when

incipient boiling occurs, and the temperature of the anode wall may therefore exceed that of boiling water.

Where the water supply is hard and scale is deposited the anode temperature is liable to rise sufficiently to result in overheating of the anode-to-glass seal. To counteract this the seal is commonly cooled by some auxiliary system, such as a special air blast, and the water supply is required to conform to a minimum standard of purity. A satisfactory standard is that the dissolved solids shall not exceed 10 parts per 100,000 and the conductivity shall not exceed 100 reciprocal megohms per cm. cube, which usually entails the use of distilled water. The rate of flow is usually between 0.25 and 0.4 gal./min. per kW of anode dissipation, which is equivalent to a temperature rise from inlet to outlet jacket of less than 15°C and usually requires a pressure of 40-50 lb./sq. in.

The jacket is sometimes made integral with the valve and may be ribbed laterally to provide a measure of flexibility and reduce mechanical stresses

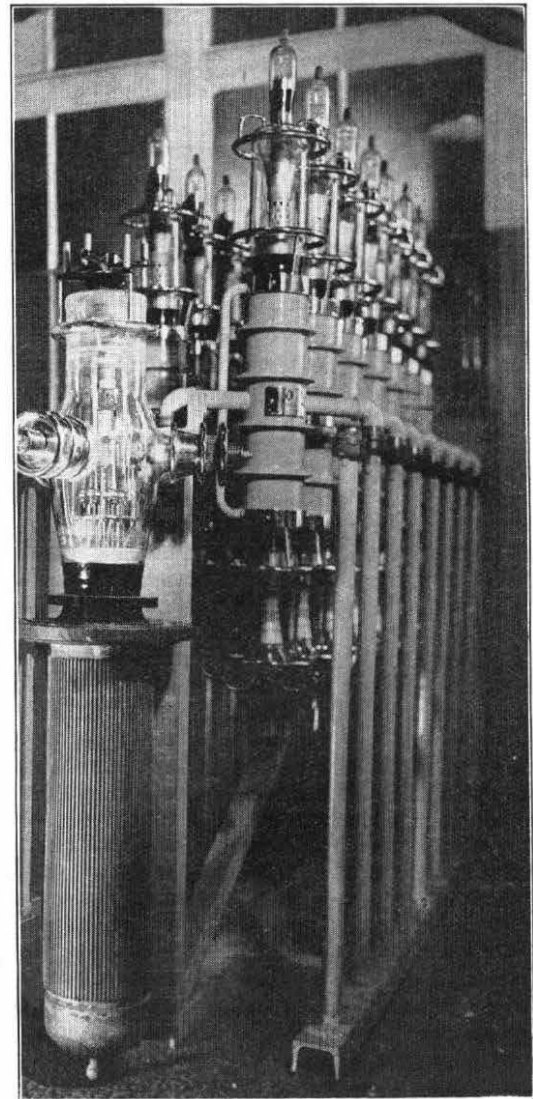

FIG. 2.—160-kW WATER-COOLED TRIODE AND A BANK OF 80-kW DOUBLE-ENDED WATER-COOLED TRIODES.

due to the difference in expansion of jacket and anode. This form of jacket is used on the row of mounted

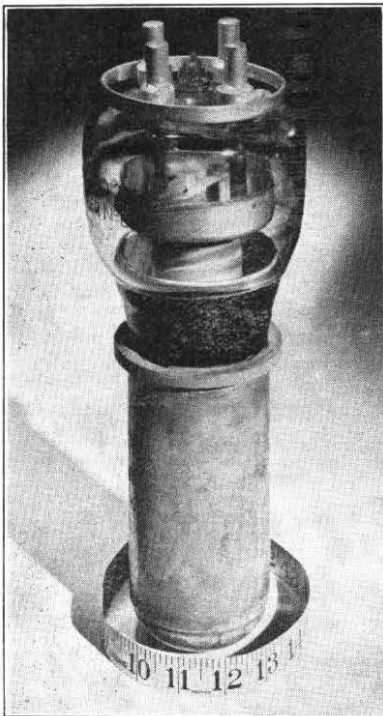

FIG. 3.—SINGLE-ENDED 20-KW WATER-COOLED TRIODE WITH THORIATED-TUNGSTEN FILAMENT.

valves shown on the right-hand side of Fig. 2. These valves are double-ended, that is grid and filament connections are led out at opposite ends, an arrangement that has an advantage from the insulation standpoint and also reduces inter-electrode capacitances, but has been superseded in short-wave valves by the single-ended arrangement which is generally more convenient for circuit layout. The 160-kW single-ended valve shown in the foreground of the photograph has a channelled anode surface to provide a greater area of contact with the cooling water.

The improved vacuum attained in modern valves has, as already mentioned, led to the use of thoriated-tungsten filaments in high-voltage valves and Fig. 3 shows a 20-kW water-cooled triode incorporating such a filament. The valve can be used at frequencies up to 30 Mc/s and has a peak usable emission of 35 amps. obtained from a thoriated-tungsten filament rated at 10V, 80amps. The maximum permissible anode supply voltage is 8 kV when the valve is subject to anode modulation, and 11 kV under other conditions. In valves of this class thoriated-tungsten filaments offer a substantial economy in heating power, equivalent to

a saving of 85 per cent. or more when compared with pure tungsten filaments, and have attendant advantages in respect of the furnace effect on other electrodes and of hum arising from the modulation of the electron stream by the magnetic field due to the filament current. There is, moreover, a reduction in the mechanical forces to which the filament is subject, which are proportional to the square of the heating current, and the problem of supporting the filament is eased. Both types of filament suffer from the disadvantage that their resistance when cold is very much less than when hot, and the voltage applied initially must be reduced considerably below the normal value to avoid mechanical distortion due to excessive current. A limit of 150 per cent. of the normal current is sometimes stipulated for the surge current.

The water-cooled valve on the right-hand side of Fig. 4 is a good example of modern high-power transmitting valve practice and illustrates the general trend of development that has been brought about by the need for extending the upper frequency limit of operation. This limit is determined primarily by two factors, the physical dimensions of the valve and the current-carrying capacity of the grid seal. The construction should be compared with that of the earlier valves of comparable power rating shown in Fig. 5, in which side-entry grid seals are used. In the more modern valve the grid is supported on one end of a cylinder at the opposite end of which there is a metal flange sealed to the glass envelope. This form of construction results in a very low inductance of the grid lead and allows large grid currents to be handled without difficulty. The principle of supporting electrodes directly from the seals is important

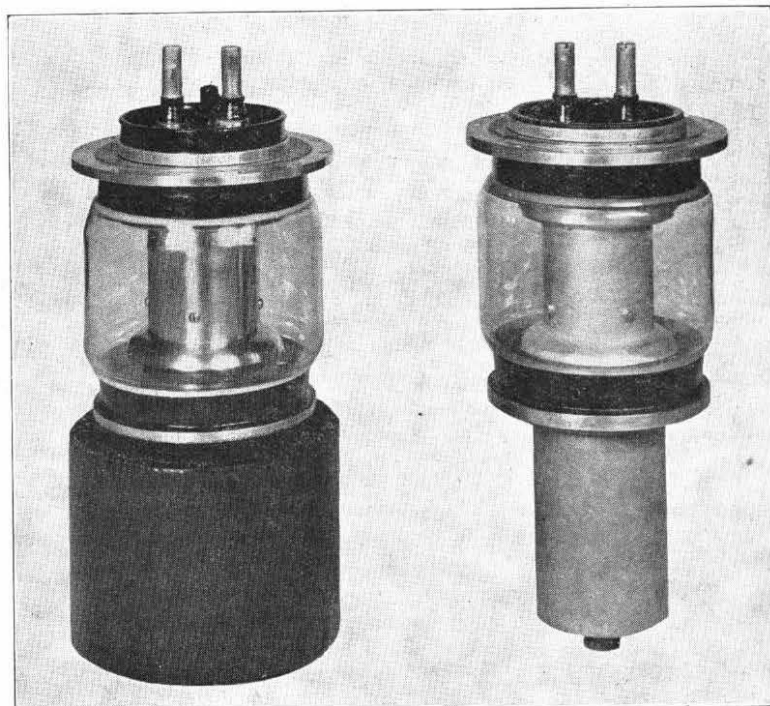

FIG. 4.—RIGHT, 20-KW SHORT-WAVE WATER-COOLED VALVE; LEFT, A FORCED-AIR-BLAST VERSION CAPABLE OF 10 KW ANODE DISSIPATION.

in so far as it dispenses with insulating supports in the more active parts of the valve.

#### *Air-Cooled Valves.*

The larger type of modern forced-air-cooled valve can be regarded as having evolved from the smaller

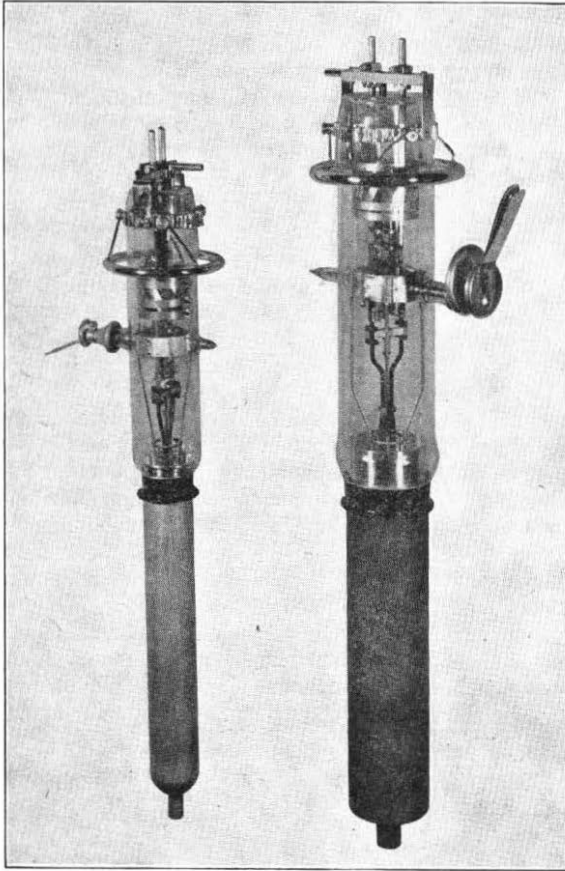

FIG. 5.—18-KW TRIODE (RIGHT) AND 12-KW TRIODE, WITH SIDE-ENTRY GRID SEALS.

single-ended water-cooled valve. The construction is basically the same, the water-jacket being replaced by a radiator or cooler usually of the type shown in Fig. 6 and comprising a copper sleeve to which are brazed a large number of radial, blackened-copper cooling fins. For certain valves the system of cooling is optional in so far as a water-jacket or cooler may be supplied as desired. The radio frequency characteristics of the valve are unaffected by the change, but the large anode structure necessary for air cooling results in a higher anode-earth capacitance. A dissipation of about 4 watts per sq. in. of cooling fin surface is reasonable with a circulating air system, usually suction, of 60-100 cu. ft./min. per kW of total anode dissipation. Such a system keeps the temperature of the cooler below about 160°C, which corresponds to a dissipation of 200-400 watts per sq. in. of effective anode surface, that is, equivalent to a little less than one-half the dissipation that can be allowed with water cooling. The temperature of the outlet air is about 15°C above ambient and the maximum outlet temperature is often specified as 45°C. Valves

of the type shown in Fig. 6 have been developed for anode dissipations up to about 20 kW, which is sufficient for the majority of commercial applications. Another form of cooler sometimes adopted comprises several crimped concentric sheaths.

As in water-cooled valves, the temperature rise of the circulated cooling medium can be used as a measure of the power dissipation at the anode, but it is not practicable to calculate the relationship for air coolers and a calibration is made with the valve running under static conditions with known anode dissipations.

Air-cooling systems of the above types have great possibilities. There appears to be no reason why the same advances should not be made in cooling valves as have been made in the cooling of aero engines by using carefully designed ducts that ensure the maximum heat transfer with the minimum resistance to air flow, and there is no reason why an air-cooling system on these principles should not be extended eventually to valves of the highest power ratings now in use. It may also be applied to relatively low-power valves with advantage if, by so doing, the physical dimensions of the valve can be

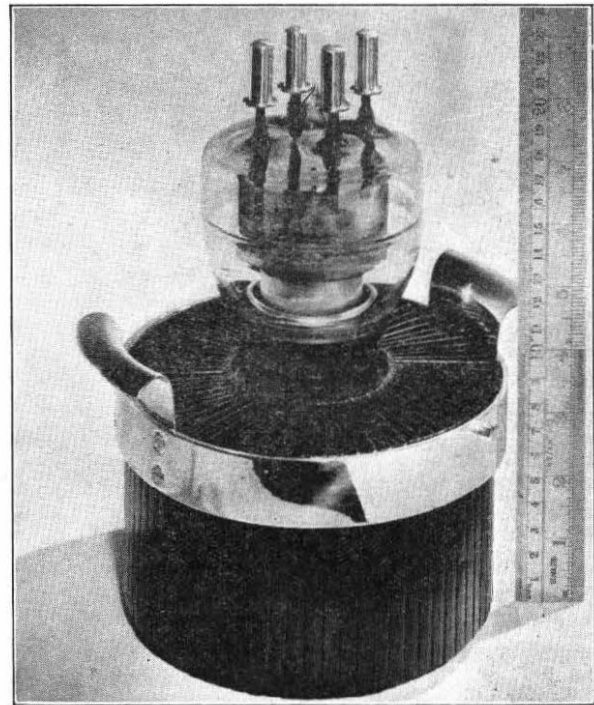

FIG. 6.—FORCED-AIR-COOLED TRIODE, 4.5 KW ANODE DISSIPATION.

reduced and the efficiency at high frequencies raised. Fig. 7 is an example of a valve of 1 kW maximum anode dissipation which by virtue of its small size is capable of effective operation at frequencies up to 100 Mc/s. An open-ended cylinder is used to support the grid and three connections from it are led out to ensure that the inductance is low. The filament in this case is centre-tapped. The valve requires an air-flow of 80 cu. ft./min. at a pressure of 2 in. of water.



High-power valves are relatively fragile, the seals being the weakest points because of the relatively heavy electrode assemblies that they are required to

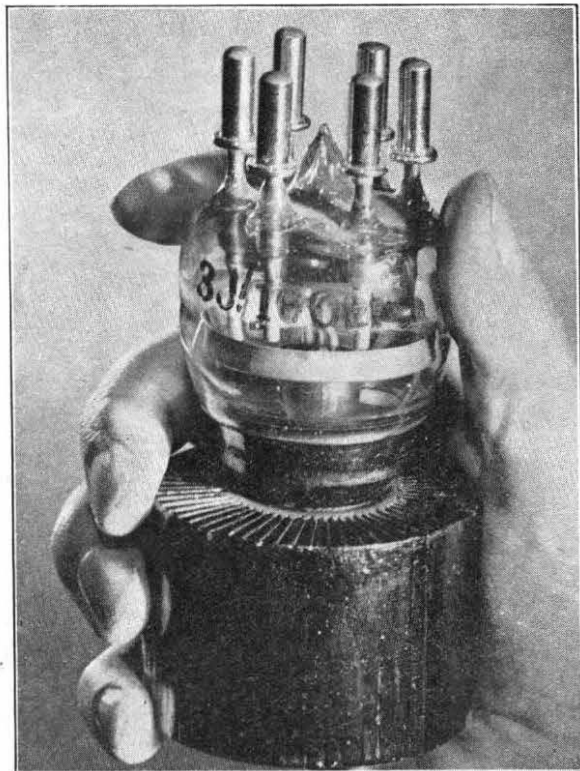

FIG. 7.—FORCED-AIR-COOLED TRIODE, 1 kW ANODE DISSIPATION.

carry. The problem of ensuring safe transport therefore becomes a very real one, especially in view of the rising demand for valves of this category for industrial R.F. heating.

#### VALVE LIFE

The replacement of high-power valves is a major item in the cost of running transmitting stations and the length of life is therefore of great importance. Unlike the receiving type of valve with its random failure characteristics, the life of a transmitting valve can be predicted with considerable accuracy. This is because, neglecting accidents, the life is almost always limited by the evaporation of tungsten from the filament, or thorium, when thoriated-tungsten filaments are used; all other causes of failure have been virtually eliminated by careful design and construction, and by rigid control of materials. Tungsten filaments fail consistently when the diameter is reduced by evaporation to about 90 per cent. of its original value. The actual failure occurs when a short length of the filament locally overheats; the effect is cumulative and rapidly leads to a complete burn-out at this point. The rate of evaporation is independent of the diameter and therefore the life is directly proportional to the diameter of the filament.<sup>4</sup>

<sup>4</sup> "The Development of Large Radio Transmitting Valves." *Marconi Review*, 1936, No. 61, p. 6.

Data are available that enable the life of a filament to be calculated when the dimensions and operating temperature are known and the valve life is therefore predictable and to a certain extent within the control of the designer.

In a given type of valve with a given emission requirement the variables affecting life are therefore filament diameter and temperature. For the same emission a filament of large diameter requires more power to maintain it at the required operating temperature than one of small diameter, but the latter has the shorter life. There is, consequently, an optimum diameter determined by the replacement cost of the valve and the cost of the filament heating power. Practical considerations also influence the final choice of the filament diameter, but, generally speaking, transmitting valves are economic when the designed life is in the region of 5,000-10,000 hours; nevertheless, by carefully regulating the filament voltage on the lines indicated below a life of about 20,000 hours may be nearer the average obtained.

Tungsten filaments are rated on an emission basis, that is the filament voltage is specified for the required emission for each individual valve. It is imperative to adhere strictly to this voltage if the design life is to be achieved, and a 5 per cent. increase in voltage will roughly halve the life; conversely a 5 per cent. decrease in voltage will double the life at the cost of decreased performance. In practice the filament is often under-run slightly during the beginning of its life, and the voltage is increased gradually to maintain constant emission. The life will then be nearly as long as if the filament voltage had been maintained constant and the progressive reduction in emission had been tolerated.

The above considerations do not apply to thoriated-tungsten filaments, which suffer negligible evaporation in the course of their effective life and depend for their operation upon the maintenance of an active surface layer and a balance between evaporation and diffusion of thorium. Operation of the filament at a reduced voltage then has the effect of shortening the life.

#### Future Developments.

It is always difficult to predict the future but there are indications that valves with silica envelopes may become more widely used for radiation-cooled valves.

Improvements in exhaust technique may eventually lead to the use of thoriated-tungsten filaments in transmitting valves of the highest powers and so render the tungsten filament obsolete. The possibility exists also of extending forced-air-cooling systems to such valves but the difficulty of reducing the accompanying noise remains to be solved.

#### Acknowledgments.

The illustrations of transmitting valves used in this article were kindly supplied by Standard Telephones & Cables, Ltd. (Figs. 2, 3, 6 and 7), the General Electric Company, Ltd. (Figs. 4 and 5), and the Mullard Wireless Service Company, Ltd. (Fig. 1).

# The Recovery of two Timber Lattice Masts

CAPT. S. HELM, A.M.I.E.E.

U.D.C. 621.315.668.1

The author gives a brief account of an unusual work entailing the dismantling of two timber lattice masts, one 240 ft. and the other 140 ft. high. The recovery work yielded about 60 tons of good quality timber, suitable for conversion into a variety of line stores.

## Introduction.

TWO wooden self-supporting lattice masts were recently purchased by the Engineering Department for use of the recovered sections for pole-arms, stay-blocks, guards and other line stores. Both masts, which had been erected 7 years, were originally 240 ft. high, but one had been damaged by aircraft and only the lower part, of 140 ft., remained. The masts were 45 ft. wide at the base and tapered to 6 ft. at the top. The wood, which was in good condition throughout, was first quality British Columbian pine, incised and creosoted.

The masts embodied the usual horizontal and vertical bracings fixed externally and internally. Platforms were provided at 30-ft. intervals vertically and were connected by stout ladders which were the normal means of ascent. The mast legs varied in section from 10 in. by 10 in. at the base, to 4 in. by 4 in. at the top. Bracings were  $7\frac{1}{2}$  in. by  $2\frac{1}{2}$  in. at the base but reduced in section in the upper parts of the mast.

Details of typical bracings at the base appear in Fig. 1, which also shows the general form of the 240-ft. mast in the distance.

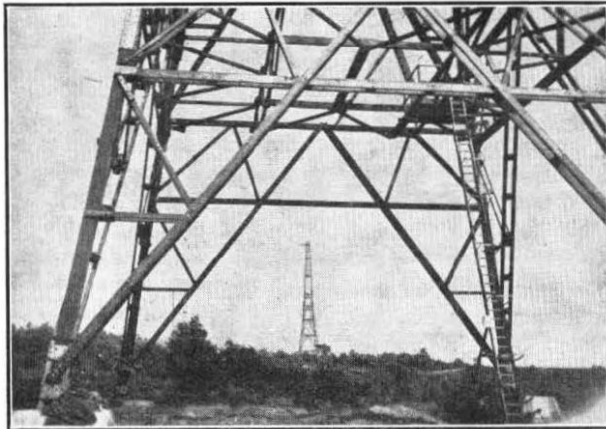

FIG. 1.—BASE OF ONE OF THE MASTS.

## Tackle Used for Dismantling.

The usual rigging tackle used in mast erection consists of a derrick set up centrally inside the mast, luffing being carried out by guys run from the butt and from the derrick centre out to the mast legs. Such an arrangement enables the derrick to be manoeuvred to any position for vertical lifts, but suffers from the disadvantage that the support is rather flexible and may allow the derrick to sag unduly under heavy loads. For this reason, and because the internal bracings of the mast would have prevented

the free use of such a derrick it was decided to employ four separate derricks, one lashed to each leg of the mast. The derricks lashed in position are shown in Fig. 2, and the lashing of a derrick at its butt in Fig. 3.

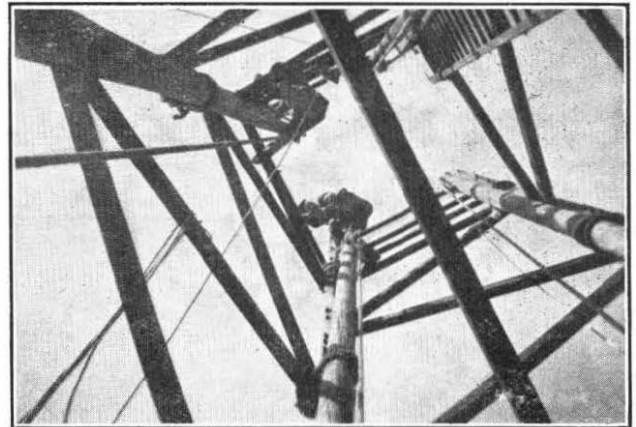

FIG. 2.—DERRICKS LASHED IN POSITION.

Each derrick was fitted with a hauling line and a 3-in. snatch block at its head. The hauling lines were taken to the ground level inside the mast bracings, and thence to guiding pulleys at the mast base. A 30-cwt Morris truck was used for hauling. The lorry traversed backwards and forwards on a straight strip of firm ground which enabled the driver to see the position of the load throughout and to take signals as required.

## Dismantling Operations.

Having set up the derrick and ropes, dismantling of the upper sections was begun, single wooden sections being unbolted and passed down the centre

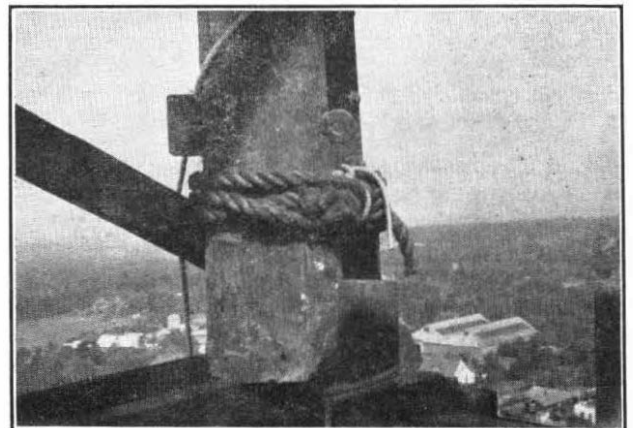

FIG. 3.—LASHING AT BUTT OF DERRICK.

of the mast by light block and line. Bolts were lowered in bags, and tools required by the riggers were sent aloft by the same means. Complete sections were then lifted clear and under the control of a light line were lowered to the ground. A top section being lowered in this manner is shown in Fig. 4. While

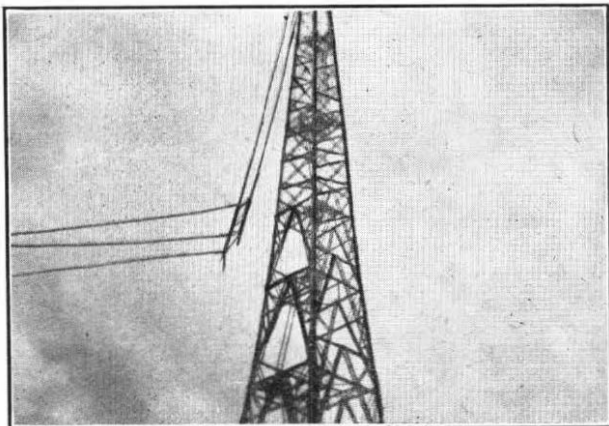

FIG. 4.—LOWERING A TOP SECTION.

overhead work continued ground staff dismantled and stacked the lowered sections. To lower the derricks a light block was rigged, coupled at the top to the highest point of the mast and hooked at the bottom into the eye bolt in the derrick butt (see Fig. 5). The load of the derrick was taken and held by two men on the nearest platform. The lower lashing of the derrick was then removed and the upper lashing slackened to a loop. The derrick was now free to be lowered to the next required position and could be relashed securely to the mast legs and bracings. All bolts were found to be in good condition and no special difficulty was met in their removal. Further, the joints were securely locked by dowels and, the timber having shrunk slightly, removal of the bolts was easily carried out. In addition to lowering the derricks it was necessary at each section to clear the ladders, platforms and internal bracings. The transfer of the ladder from its position on the platform to a lashed vertical position on the side of the mast considerably reduced the time of dismantling.

As the work progressed, the heavier sections necessitated the use of double purchase tackle from the

140-ft. level downwards. This permitted safe loads on the hauling ropes and better control during the initial lifting. When only the last section was left

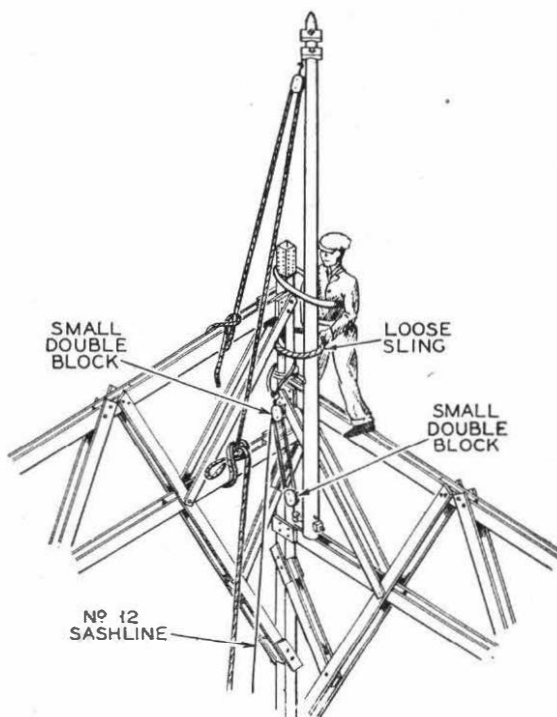

FIG. 5.—LOWERING A DERRICK.

standing the derricks, ladders and internal bracings were recovered and the site cleared.

#### Conclusion.

The masts were in a very exposed position overlooking the Devil's Punch Bowl, Surrey. High winds often made progress aloft arduous, but only on one day was the work suspended by bad weather. The masts yielded about 60 tons of timber which was converted into a variety of line stores as described earlier. Two external gangs from the Guildford Area were employed on the work under the direction of Mr. A. E. Ayers, five men working aloft and five on the ground. The work aloft was carried out by volunteers whose skill and courage are to be highly commended.

## Book Review

"Electric Cables." Frances W. Main, M.I.E.E. Sir Isaac Pitman & Sons, Ltd. 142 pp. 52 ill. 12s. 6d.

This issue is the third edition of Mr. Main's primer on electric cables and has been re-written and brought up to date. The art and science of cable making, testing, and using has been very largely neglected by text book writers and this work fills a need. The materials, manufacture and properties of all types from bell wire to super-tension cables are dealt with, together with much practical information on selection of types, methods of

laying, transmission systems, design considerations, testing and maintenance.

The author is clearly much more at home with power than with telephone cables, but as an introductory survey of a wide field the book can be confidently recommended, although the price is somewhat high for a primer.

Two small points may be mentioned: Unit Type Telephone Cable was evolved in the United States, not in Britain; and it is a pity to continue the use of the term "Polyethylene" now that B.S.I. and other authorities have agreed to call the material "Polythene."

L. G. D.

# An Electronic Distortion Measuring Set for Start-stop Telegraph Signals

L. K. WHEELER, B.Sc.(Eng.), A.M.I.E.E., and  
R. S. TISSINGTON, B.Sc.(Eng.), A.M.I.E.E.\*

U.D.C. 621.394.813 : 621.317.74

The instrument is designed to measure the distortion of teleprinter signals at a speed of 50 bauds. It can be connected to working circuits, and instruments of this type will be installed in the test desks at telegraph switching centres.

## Introduction.

IN teleprinter transmission each character signal comprises seven elements; the first, or start, element is always of spacing polarity, being followed by five elements which denote the character in binary code and finally a stop signal which is always of marking polarity. The first six elements are nominally of the same (unit period) duration, whilst the stop signal may have a nominal minimum duration equal to, or greater than, the unit period according to the system (1.5 units in the British system). A succeeding character may be commenced at any instant after the expiration of the minimum stop signal period.

The cycle of the receiving mechanism of a teleprinter is initiated by the reception of the start element and terminated during the stop signal, the mechanism then remaining quiescent until the advent of the next character. Once the cycle has commenced, the process of sampling the incoming signal at the nominal mid-instants of the code elements is controlled by the machine alone. The accurate registration of the code elements depends upon the correct time relationship of the signal transitions with the start element having been preserved within certain limits during transmission.

It is evident, therefore, that a device which will indicate accurately the timing of the instants of modulation (signal polarity transitions) in a character relative to the start signal of the character, and automatically phase itself with each start signal, will be a useful instrument for the study of start-stop transmission systems and in the maintenance of circuits and equipment.

Up till this time, the only distortion measuring instrument used by the British Post Office suitable for measurement of teleprinter signals, has been the Distortion and Margin Tester (Tester TG 956/958)<sup>1</sup> and this has certain severe limitations. It is quite suitable for local measurements of transmitter distortion when a single character is repeated at machine speed (i.e. "plugged" speed), but its use for the accurate measurement of distortion at the end of a circuit, when fortuitous distortion is present, is difficult, and when the character repetition is at a random rate, it is impossible. This is due to the fact that it was not designed to operate in a start-stop manner, and hence the instant of the start-signal and the zero of the time scale for reading the displacements of the instants of modulation are seldom coincident.

As long ago as 1939, the need for a start-stop distortion measuring set was recognised and work on the development of an electronic instrument had commenced, but was suspended at the outbreak of war in favour of more urgent projects. Recently the development has been continued, advantage being taken of intervening advances in the use of electronic circuit technique, and has resulted in the instrument to be described. Similar measuring sets will be installed in test desks at the switching centres of the telegraph automatic switching system.

## Principles of the Electronic T.D.M.S.

Since the measurement of telegraph distortion is effectively the measurement of the relative times of occurrence of electrical phenomena, an obvious means of measurement is to use a cathode-ray oscilloscope with a suitable time-base and employ means of modifying the trace to indicate the incidence of the phenomena, i.e. the instants of modulation. This is all the more suitable for a start-stop measuring device, as the effects of the inertia of moving parts and the lack of precision in the operation of clutches in an equivalent mechanical device can be avoided. Two methods of indication by varying the trace are available—variation of intensity of the beam and deflection of the beam. As two types of measurement will be required, distortion and transit time, both methods are used. Because the more frequently used facility will be that of distortion measurement, the brightening of the trace has been chosen to give this indication, as the background trace can be suppressed to leave only the bright spots visible to indicate the instants of modulation on the time scale. Deflection of the beam is employed to indicate the instants of commencement and completion of the transit period when making measurements directly on a transmitting contact assembly, i.e. without any other circuit or spark-quench connected to the tongue. Measurement is made by reading the positions of the indications from a graduated scale. This method facilitates the measurement of fortuitous distortion, which is further aided by the use of a cathode-ray tube screen with a moderately long afterglow.

The primary time-base period is made equal to the nominal time of a unit signal element (20 mS for a telegraph speed of 50 bauds) and the cathode-ray traverse is repeated for each possible signal transition during the reception of a teleprinter character (i.e. six traverses). To permit the reading of the distortion of individual instants of modulation in a character, the six traverses are mutually displaced by a suitable vertical deflection circuit, so that the general form

\*Now with Telecommunications Dept., Federation of Malaya.

<sup>1</sup>*P.O.E.E.J.*, Vol. 26., p. 3.

of the working part of the trace is a column of six horizontal lines (see Fig. 1). The repetition rate of the

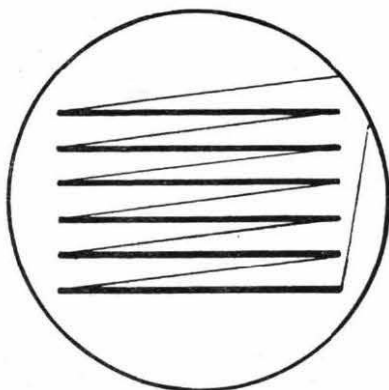

FIG. 1.—CATHODE-RAY TUBE TRACE.

time-base is controlled by an oscillator which is automatically started when the start element of each character is received and stopped when the correct number of beam-traverses has occurred. When just an overall distortion measurement is required, the separation of the individual element traces may be eliminated. To facilitate the reading of the distortion of the instants of modulation, which may be either advanced or retarded relative to their correct times with respect to the start element, the commencement of the time-base cycle is delayed by a period of half a unit element (10 mS for a telegraph speed of 50 bauds), so that undistorted signals are indicated at the centre of each traverse.

The use of a rectilinear beam-sweep entails the provision of means of calibration to ensure that a linear measurement of the horizontal traverse against a fixed scale represents accurately a time interval. This is provided by making the frequency of the time-base controlling oscillator six times that of the time-base itself, so that signal indications which are accurately 0,  $+33\frac{1}{3}$  and  $-33\frac{1}{3}$  per cent. relative to perfect signals can be used to mark the trace (see Fig. 2). By manipulation of the horizontal shift and gain controls, these markers may be positioned to agree with the corresponding points on the fixed scale.

Measurement of the transmission speed can be easily made, if the transmission is at the maximum character repetition rate, by eliminating the separation of the element traces and the automatic start-stop action, so that the primary time-base runs continuously. The indications of the instants of modulation will move across the screen at a rate proportional to the speed error. This is measured by varying the time-base frequency with a calibrated control to attain

synchronism. To ensure the maintenance of accurate measurement, means are provided for checking and

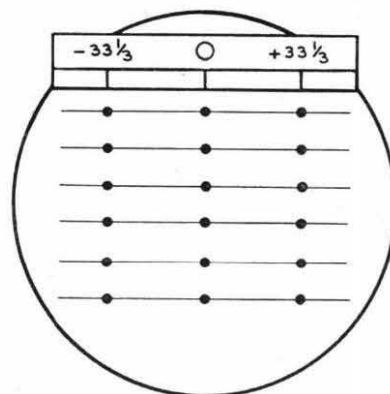

FIG. 2.—CALIBRATION OF SCALE.

adjusting the frequency of the time-base control oscillator against an external standard.

*Description of the Instrument.*

A T.D.M.S. designed on the foregoing principles is shown in Fig. 3.

The C.R. tube has a 6-in. screen and is provided with a scale of length 4 in., graduated over the range  $\pm 40$  per cent. distortion. The calibrated control for direct speed measurement has a range of  $\pm 1.1$  per cent. of the nominal speed. The total

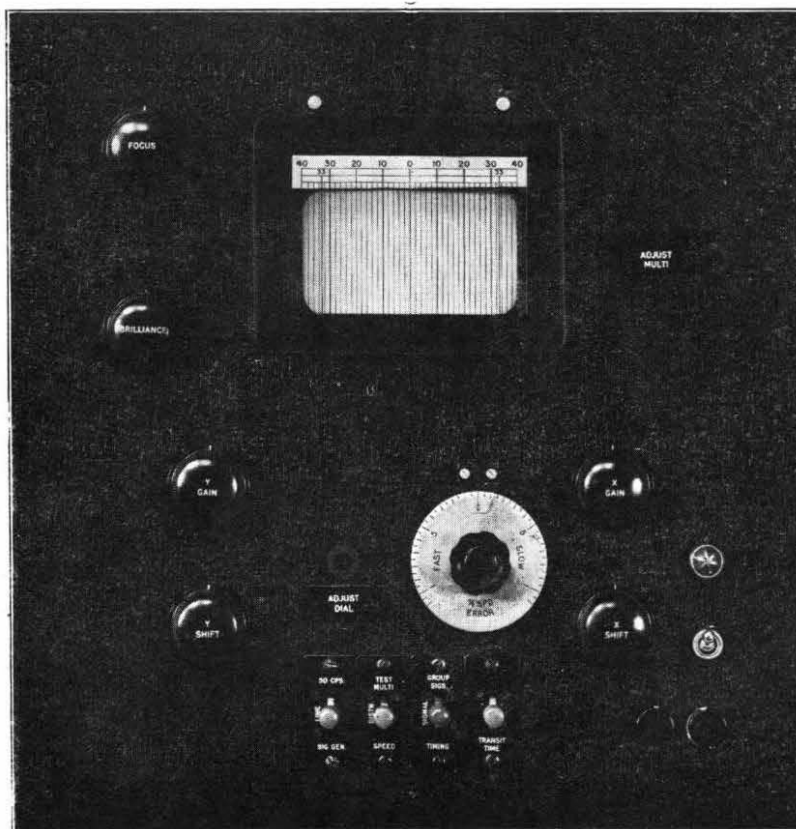

FIG. 3.—FRONT VIEW OF THE T.D.M.S.

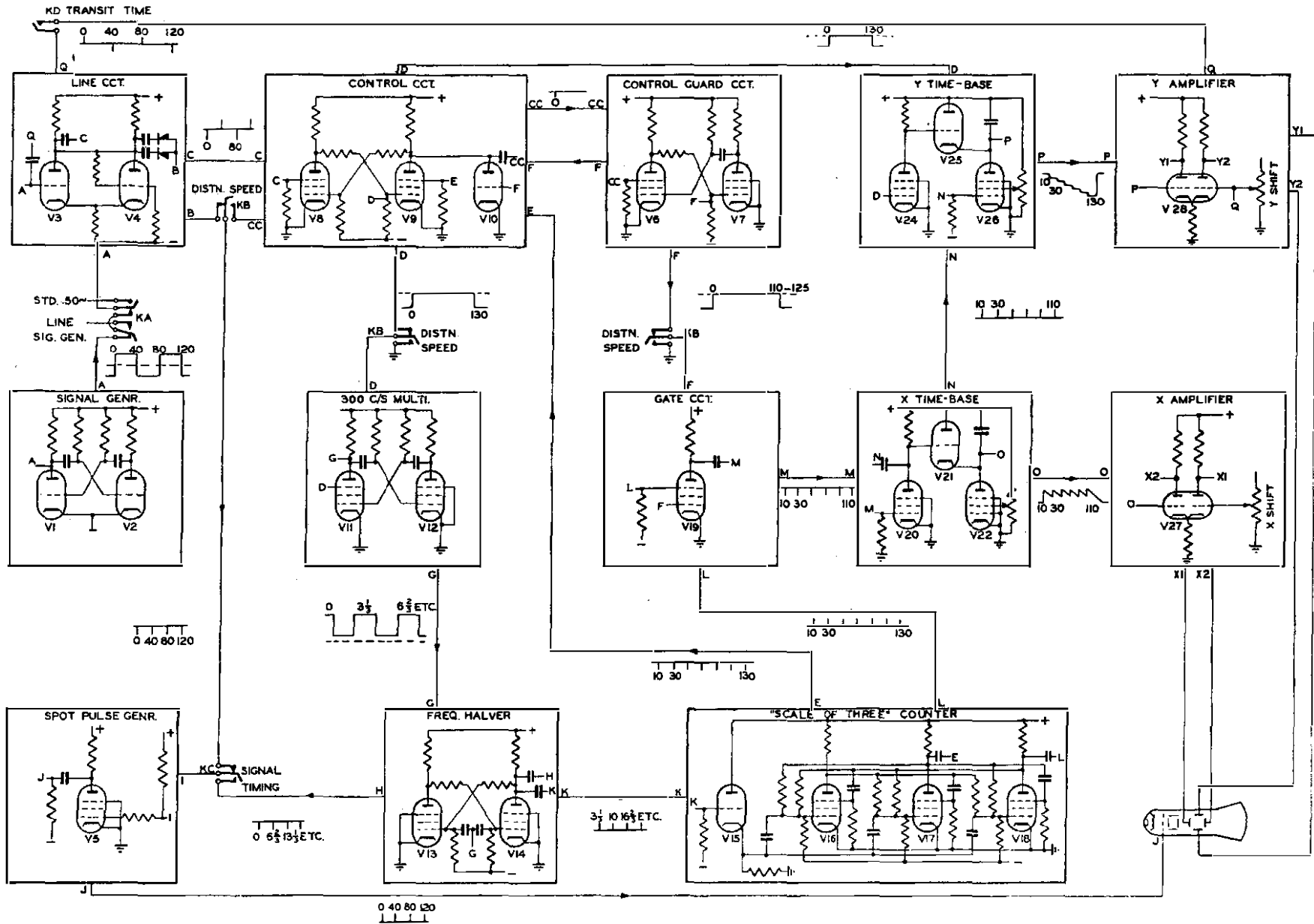

FIG. 4.—SCHEMATIC DIAGRAM OF THE T.D.M.S.

number of valves employed is 34; 26 of these are miniature valves which are used in the switching circuits, whilst the deflection amplifiers and power rectifiers are normal-sized valves.

The overall dimensions are  $14\frac{1}{2} \times 14\frac{1}{2} \times 18\frac{1}{2}$  in., the weight is 60 lb. and the power consumption 140 watts from A.C. mains.

#### *Outline of Circuit Operation.*

The operation of the switching circuits of the electronic T.D.M.S. may be followed by reference to the simplified schematic diagram shown in Fig. 4. The voltage waveforms shown in this diagram are those which exist when the instrument is employed for the measurement of distortion, the input signal being derived either from the local signal generator (V1, V2) or from a teleprinter generating the letter I, depending upon the setting of key KA. The signal generator is for use as a source of signals to assist in setting up the instrument when there are no line signals available, and is a continuously running multivibrator with a relaxation time of 40 mS. It therefore gives reversals at  $t=0, 40, 80$  and 120 mS, simulating the continuous transmission of the letter I in the teleprinter code. The line circuit, which is a Schmitt trigger, acts as a signal shaper and generates a steep-fronted reproduction of the input signal waveform. Differentiation of the waveform at the anode of V3 produces negative impulses at each mark-to-space transition and positive impulses at each space-to-mark transition. Impulses at the same instants, but of the reverse polarity, are produced at the anode of V4. The impulses from V3 are applied over path C to the control circuit. This circuit, a two-position trigger, is operated by the impulse at  $t=0$  and generates a negative impulse at CC, which actuates the control guard circuit, a pulse trigger with a pre-determined period of between 110 and 125 mS. The operated control guard circuit holds the control circuit in its operated condition and also opens the gate circuit, when key KB is set at DISTORTION, over connections F.

The operation of the control circuit permits the 300 c/s multivibrator V11, V12, which is the time-base controlling oscillator, to commence oscillating by applying a positive potential to the latter over path D, when key KB is set at DISTORTION. This multivibrator drives the frequency halver over path G, the negative driving impulses occurring at the instants  $t = 0, 3\frac{1}{3}, 6\frac{2}{3}$  mS, etc. Positive impulses are derived from the frequency halver to drive the scale-of-three counter at  $t = 3\frac{1}{3}, 10, 16\frac{2}{3}$  mS, etc. over path K and negative impulses at  $t = 0, 6\frac{2}{3}, 13\frac{1}{3}$  mS, etc., are taken over path H to the spot pulse generator with the key KC set at TIMING (when calibrating the scale). The scale-of-three counter is stepped on by impulses every  $6\frac{2}{3}$  mS, commencing at  $t = 3\frac{1}{3}$  mS, and produces negative impulses at  $t = 10, 30, 50$  mS, etc., which are applied to the control circuit over path E. The first six of these impulses are ineffective in restoring the control circuit because it is, as already described, biased by the control guard circuit for a period of between 110 and 125 mS from the commencement of the start signal. The seventh resetting impulse, at  $t = 130$  mS, is effective and the

control circuit is restored at this instant. The control circuit therefore remains operated for a period of exactly 130 mS from the commencement of the start signal, after which it restores and prevents further operation of the multivibrator, frequency halver and scale-of-three counter.

The scale-of-three circuit also generates positive impulses which are fed to the gate circuit over path L. The gate circuit is kept open by the control guard circuit over path F for a period of 110-125 mS, and therefore permits the passage of the first six of the impulses from the scale-of-three counter, but rejects the seventh impulse, at  $t = 130$  mS. Therefore, the output of the gate circuit consists of six negative impulses at  $t = 10, 30, 50$  mS, etc., which are transmitted over path M to the X time-base generator. The X time-base circuit generates a linear saw-tooth waveform by charging a capacitor from a constant current source, i.e. the pentode V22. The capacitor is discharged and allowed to recommence charging at the instants  $t = 10, 30$  mS, etc. The charging rate can be controlled by varying the screen potential of the valve, thus controlling the input to the X amplifier and therefore the amplitude of the horizontal deflections of the C.R.T. The output of the X time-base generator is applied to the X amplifier over path O, and thence to the horizontal deflector plates of the C.R.T. From the waveform shown, it is clear that there will be six horizontal traces on the screen of the tube, the spot moving off the screen towards the right on the completion of the last trace.

The X time-base circuit also generates six positive impulses at  $t = 10, 30$  mS, etc., which are fed to operate the Y time-base circuit. This circuit generates a stepped voltage waveform which is applied over path P to the Y amplifier and thence to the vertical deflector plates of the C.R.T. The waveform which is shown at point P is produced by the intermittent charging of a capacitor in the anode circuit of the valve V26 at the instants  $t = 10, 30$  mS, etc. The magnitude of the charging current, and therefore of the voltage steps, is adjusted by means of the potentiometer in the screen circuit of V26. The capacitor is discharged by the action of the control circuit at  $t = 130$  mS over path D, thus causing the spot to move vertically off the screen of the tube at this instant.

The combined effect of the X and Y deflecting voltages is to cause the spot to make six horizontal sweeps across the screen of the C.R.T., there being a vertical displacement between each sweep. These sweeps commence at the instants  $t = 10, 30, 50$  mS, etc., the duration of each sweep being 20 mS. Normally, the BRILLIANCE control is adjusted so that the traces are not visible when making measurements of distortion.

The X and Y time-base amplifier circuits, which are basically identical, are cathode-coupled push-pull amplifiers and give symmetrical deflection voltages to the plates of the C.R.T.

#### *Production of Displays on the C.R.T. Screen.*

With KC set at TIMING, and signals being received from line or the internal signal generator, calibrating impulses derived from the frequency halver at H will

be applied to the spot pulse generator with the result that the trace on the C.R.T. screen will be brightened at instants  $13\frac{1}{2}$ , 20,  $26\frac{3}{4}$  mS, etc., after the commencement of the start element. The X gain and shift controls are then adjusted so that the spots coincide with the  $-33\frac{1}{2}$ , 0 and  $+33\frac{1}{2}$  per cent. scale graduations.

With the key KC set at SIGNAL, the spot pulse generator is connected to B of the line circuit, at which are produced negative impulses at each instant of modulation of the received signal, these impulses being derived by rectification of the differentiated waveforms occurring at the anodes of V3, V4. Taking as example the character I, the spot pulse generator applies positive impulses to the modulator grid of the C.R.T. over path J at the nominal instants of 0, 40, 80, 120 mS. These produce on the second, fourth and sixth traces bright spots, which will be displaced from the centre to the left or right, according to whether they occur before or after their nominal times. The amount of displacement, or distortion, can then be read from the graduated scale as a percentage of the unit element period.

With key KD operated to TRANSIT TIME, the change of potential occurring at the point A in the line circuit, when the transmitting contact commences its transit, is passed over path Q to the Y amplifier to cause a small vertical deflection of the trace at this instant, which may be viewed by increasing the brilliance of the trace (see Fig. 5). The horizontal displacement

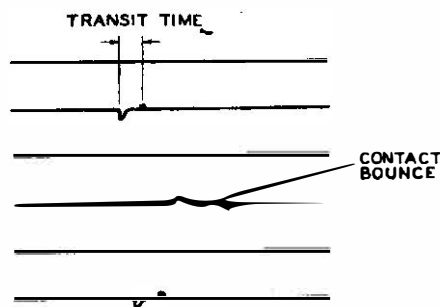

FIG. 5.—C.R.T. DISPLAY SHOWING TRANSIT TIME.

between a deflection and the bright spot on the same trace, which occurs when the contact has completed

its transit, is a measure of the duration of the transit time of the contact. Additional deflections subsequent to the spot indicate the occurrence of contact bounce.

The duration of the transit and of contact bounce is easily resolved from the distortion scale, as 5 per cent. corresponds with a time interval of 1 mS.

#### Measurement of Teleprinter Speed.

When key KB is set at SPEED, the multivibrator is disconnected from the control circuit and runs continuously. The gate circuit is disconnected from the control guard circuit and held open. Thus, the X time-base is permitted to run continuously. Another contact of key KB (not shown) is employed to disconnect the input to the Y amplifier, so that there is no vertical displacement between sweeps. The input of the spot pulse generator is disconnected from the line circuit and connected to the control circuit so that it receives a single negative impulse at the commencement of each character. With  $7\frac{1}{2}$ -unit characters, two spots will now be observed on the screen of the C.R.T., these spots moving across the screen towards the left or right according as the machine speed is fast or slow. The frequency of the multivibrator is now adjusted until the spots become stationary and the percentage speed error of the machine read directly from a graduated dial, which has a range of  $\pm 1.1$  per cent. speed error. (To simplify the diagram, the arrangement for varying the frequency of the multivibrator has not been shown. When key KB is operated, the fixed timing resistors are replaced by variable ones to permit adjustment of the frequency).

#### Conclusion.

The introduction of this instrument into service should greatly facilitate the accurate measurement of distortion in teleprinter systems, and enable measurements to be made during the actual operation of circuits, a process which hitherto has proved to be difficult.

The authors would like to acknowledge the assistance given by other members of the Telegraph Group of the Research Branch in the development of this instrument.

## Book Review

"Fractional Horse Power Motors." C. G. Veinott. McGraw-Hill Publishing Co., Ltd., London. 538 pp. 383 ill. 30s.

The author has taken the opportunity of a second edition to re-write portions of the book and to rearrange the subject-matter dealing particularly with maintenance and the application of fractional horse-power motors. Small electric motors have innumerable uses both in domestic and industrial appliances and this book is a comprehensive survey of present-day practice in the U.S.A. in this field. The fact that it is U.S.A. manufacturers' products which are dealt with is brought out in the first chapter, in which the "Story behind the nameplate" is told, and code letters for various manufacturers are given. The definition of horse-power rating

and of fractional horse-power motors are not those in general use in Great Britain. The greater portion of the book is devoted to A.C. motors, but the treatment of small D.C. and universal motors is adequate.

The purpose of the book is to present comprehensive information which will be of value to practical men dealing with maintenance and repair problems and also to those designers who have to incorporate small motors in machines of one sort or another. This purpose has been fulfilled in a very well-produced and illustrated publication. It can be recommended as being authoritative on U.S.A. practice, but the reader should bear in mind that the descriptions given do not necessarily apply to products of British manufacturers.

W. T. G.



# Television Radio-Relay Links\*

U.D.C. 621.397.743

A. H. MUMFORD, O.B.E., B.Sc.(Eng.), M.I.E.E.,  
and Capt. C. F. BOOTH, O.B.E., M.I.E.E.

Considerable interest has been aroused by the opening of the radio-relay link between London and Birmingham, which is now in everyday use for the exchange of television programme material. The article, having first outlined the transmission characteristics required of long-distance relay links, discusses the radio transmission of video signals, refers to an experimental system in use between London and Cardiff, and then describes, in some detail, the London-Birmingham radio-relay system.

## Introduction.

THE need for an effective network for the relaying of video signals between London and various provincial centres is even more important to the growth of our television service than the corresponding sound network has been to the evolution of sound broadcasting. The reason for this is twofold. Firstly, the costs of "live" studio television broadcasts are very many times greater than for sound broadcasts. Secondly, the range of television stations for a high-grade service is generally considered as limited to about 50 miles, due to the "quasi-optical" propagation of the high radio frequencies necessarily used for the purpose. Thus, to ensure a nation-wide television service, several widely-separated stations are required and, because of the prohibitive costs of live programmes, it is not practicable at present to consider the origination of live studio programmes simultaneously at all the stations.

Two methods of relaying video signals over long distances are practicable at present, the one using coaxial cable and the other radio. In the distant future, long-distance transmission by wave guide may become practicable. The comparative merits of cable and radio systems are being studied in many countries and the Post Office has embarked on a large-scale experiment between London and Birmingham in which radio and cable systems will be compared and their performances assessed. However, it is not proposed in this article to consider both radio and cable systems. Attention will be confined to an examination of the problems involved in the transmission by radio of the video signals employed in the 405-line television system now standardised in the United Kingdom and of the provision of two actual radio systems. One of these is an experimental system which has been set up by the Post Office Radio Development Branch between London and Castleton, near Cardiff. Its purpose is to provide experience of television relaying, and in particular of a relatively simple type of system. The second system connects London and Birmingham and is carrying the video programme for the recently opened B.B.C. station at Sutton Coldfield. This link has been designed and installed by the General Electric Company to a performance specification issued by the Post Office. Both links have been engineered to carry 405-line signals, but their designs differ appreciably because of the very different carrier frequencies employed, some 200 and 900 Mc/s for the Post Office and General Electric Company systems, respectively.

It is of interest to note the development and

\* This article is based on a Paper read by the authors before the Institution of Post Office Electrical Engineers.

<sup>1</sup>For references see Bibliography.

application of radio relay systems in the United States of America. A system<sup>1,2,3,4</sup> carrying two video channels between New York and Boston has been operating since 1948. The 220-mile system is divided into eight links, varying from 11 to 35 miles long. A larger project is the 900-mile system (35 links) joining New York and Chicago, which is now being installed. It is likely eventually that the New York-Chicago system will be extended to San Francisco to give a coast-to-coast system, 2,500 miles long and including some 70 intermediate relay stations.

However, despite the rapid development of broad-band radio relaying systems, it must be stressed that relatively little actual experience is available, in particular of a system containing several links in tandem, and that only as a result of experience over a fairly long period will that necessary fund of operational experience become available to the designer and to the maintenance engineer.

For the sake of completeness it should be recorded that early in 1939 the Post Office placed a contract with E.M.I., Ltd., for an experiment in the relaying of television signals to Birmingham. In this case, the radio signals from Alexandra Palace were to be received at Dunstable and transmitted over a radio link to Sharmans Hill, Charwelton, some 40 miles distant towards Birmingham; thus carrying the signals two-thirds of the way from London to Birmingham. Unfortunately, the war intervened and this early experiment in the radio relaying of television signals necessarily had to be abandoned.

## The U.K. Television Standard.

The present standard,<sup>5</sup> which will be employed for many years in this country is detailed briefly below and the waveform is shown in Fig. 1.

Number of lines	405 (202.5 + 202.5 interlaced).
Number of frames	50 per second.
Number of pictures	25 per second.
Line frequency	10,125 c/s.
Modulation	positive (amplitude).

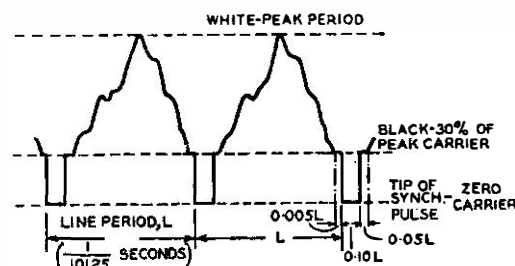

FIG. 1.—405-LINE SIGNALS, U.K. TELEVISION STANDARD  
TYPICAL LINE SIGNALS DURING FRAMES.

The signal carries two sets of intelligence, the pulse synchronising signals which ensure the exact synchronism of the electron beam in the cathode-ray tube at the receiver with the corresponding beam in the television camera at the transmitter, and amplitude-modulated signals conveying the picture detail, the demodulated signals being arranged to control the intensity of the electron beam of the cathode-ray tube at the receiver and hence to build up the transmitted picture with the help of the synchronising signals.

#### SPECIFICATION OF TRANSMISSION CHARACTERISTICS

The specification must be such as to ensure that there is no perceptible degradation of the picture after transmission over the longest distances which may be employed. This definition is a subjective one and its translation into a technical specification is a difficult matter, particularly since the subjective and objective assessments vary for different types of picture and between observers. However, the subjective characteristics must be translated into minimum acceptable electrical requirements which are capable of objective measurement and precise specification. The analysis made in the following paragraphs of this section is based broadly on the specification of the London-Birmingham system, but while it covers the main points it is not complete and is only intended to give a very general survey of what is necessarily a most complex specification. In deriving the limits for a single system it has been assumed that several such systems may be connected in tandem.

As already indicated, actual experience of long-distance television relay systems is not very extensive. In consequence, it is not certain that a correct balance has been struck between the specified electrical characteristics and their subjective result, and, as further knowledge and experience are obtained, modification of such specifications may be necessary.

#### *Frequency Band of Video Signals.*

The frequency band necessary for the effective transmission of a video signal can be determined from a consideration of a picture of black and white squares in which it is assumed that the squares are the smallest elements to be resolved, and that equal horizontal and vertical definition is required. The minimum value of the highest frequency in c/s for the effective transmission of such a picture is equal to half the number of elemental squares scanned per second, and a system with a pass band up to this frequency is satisfactory. Thus, the effective frequency band is a function of the square of the number of lines, the height-to-width ratio of the picture and of the number of pictures transmitted per second. For 405-line signals, assuming equal horizontal and vertical definition, the bandwidth requirement is some 2,800 kc/s, and for effective transmission, frequencies up to this value must be transmitted without serious loss.

The permissible variation in loss within this band is set by considerations of the smallest perceptible brightness changes that are visible in picture areas adjacent to sudden transitions. For example, departures

from a flat characteristic at the lower frequencies will cause black-to-white or white-to-black transitions to be followed by long streaks, while if the departures occur at higher frequencies the streaks become correspondingly shorter. This calls for a substantially flat attenuation/frequency characteristic free from marked changes of level from about 20 c/s to 3,000 kc/s. Over this range the maximum permissible departure from flatness is at the highest frequency where it should not exceed about 1 db. Frequencies below some 20 c/s may be attenuated in part of the circuit provided that they are finally reconstituted in a restoring circuit; this can be accomplished by restoring the bases of the synchronising pulses, i.e., the black level of the picture signal (Fig. 1), to a constant level. The sharpness of the cut-off above 3,000 kc/s is limited by phase linearity requirements, and for this reason a slow cut-off above 3,000 kc/s is usual. If too sharp a cut-off is used the equalisation of the phase/frequency characteristic becomes difficult.

The attenuation and phase characteristics are, of course, mutually dependent and must, in fact, be considered together, particularly in respect of waveform response at low frequency. It is necessary for the phase/frequency characteristic to be substantially linear from 20 c/s to 3,000 kc/s and to pass through zero when extended back to zero frequency. The maximum departures from overall linearity being about 2° between 20 c/s and 500 kc/s and increasing uniformly from 2° to 8° over the frequency range 500 to 3,000 kc/s.

#### *Transient Response and Non-linear Distortion.*

The build-up time, defined as the time taken for the response to a suddenly applied signal to increase from 10 to 90 per cent. of the ideal amplitude, may not exceed 0.2 micro-seconds. The permissible maximum value of overshoot, the amount by which the maximum instantaneous response to a suddenly applied input may exceed the steady-state response, may not exceed 2 per cent. The figures for permissible build-up time and overshoot implicitly set limits to the rate at which the response of the system may fall at above 3,000 kc/s, and the extent to which the phase characteristic departs from linearity in this region.

Considering now the limits of non-linear distortion over the range of levels occupied by the complete signal, i.e., from the tip of the synchronising pulses to peak white, the slope of the curve relating signal level at the output to that at the input of the system should be within the limits of 0.9 to 1.1 relative to the slope of an ideal linear characteristic.

#### *Signal-to-Noise Ratio and Echo Distortion.*

The presence of noise<sup>6</sup> on the video signal shows up as a brilliance modulation on the picture and the permissible amount of noise is dependent on the type of picture and on the regularity and type of the noise.

Random noise gives a non-pattern type of interference over the complete picture, and its effect is perhaps the least objectionable of all types of noise. Impulsive noise as produced by ignition systems of motor cars gives bright spots of light on the picture. These can be very disturbing

to the viewer. Noise caused by interference from other radio signals normally gives a pattern type of interference and can be very troublesome. In considering the permissible values of the several types of noise, both signal and noise will be specified in terms of their peak-to-peak values (D.A.P. values). The D.A.P. signal level is defined as the magnitude of the vision signal voltage lying between black and white, synchronising pulses being excluded. The ratio at the output of the system of the D.A.P. signal level to the D.A.P. level of noise must be not less than 50 db.

The overall gain stability, in terms of output vision signal level relative to input vision signal level, is required to be better than 0.3 db. at a reference video frequency of 10 kc/s, the quoted limit being maintained without readjustment.

The ratio of the D.A.P. signal level to the D.A.P. level of a permanent type of echo signal which is delayed by more than 0.25 micro-seconds must not be less than 40 db.

## RADIO TRANSMISSION OF VIDEO SIGNALS

### Selection of Carrier Frequency.

Perhaps the most important single problem in the engineering of a radio-relay system for television signals is the selection of the carrier frequency to be used. The wide frequency band required for a television system and the urgent needs of other services for frequencies below about 150 Mc/s set this as a lower limit for the carrier frequency of a radio-relay system. The higher limit of some 10,000 Mc/s is set by the absorption of wave energy by water vapour, snow, sleet, hail and rain, and by general fading. Thus, the frequency range which can be considered at the present time is about 150 to 10,000 Mc/s. There are, of course, many other factors which influence the selection of carrier frequency, including propagation, aerial efficiency, valve efficiency and availability, and these factors will now be briefly discussed. It is not proposed to consider the general question of international and national frequency allocation as it is outside the scope of the article, but naturally these allocations do prescribe the frequencies which may be employed.

Considering first the propagation of radio waves in the quoted range, effective transmission is only by the direct wave, ionospheric reflection not being experienced, and so the transmissions are limited to line of sight. The signal-to-noise ratio, neglecting man-made, precipitation and solar noise, for the free-space propagation of electric waves between points separated by an optical path, is proportional to

$$\frac{W_T G_T G_R}{N f^2 d^2}$$

in which  $d$  is the path length.

$f$  is the carrier frequency.

$N$  is the noise factor of the receiver, i.e., the ratio of the signal-to-noise ratio obtained from the receiver to the signal-to-noise ratio of an idealised receiver free from valve noise.

$W_T$  is the transmitted power.

$G_T$  is the power gain of the transmitter aerial with reference to that of a half-wave dipole.

$G_R$  is the power gain of the receiver aerial with reference to that of a half-wave dipole.

In some practical cases the received signal is the resultant of both the free-space wave and a wave reflected at the mid-path as shown in Fig. 2 (a). For

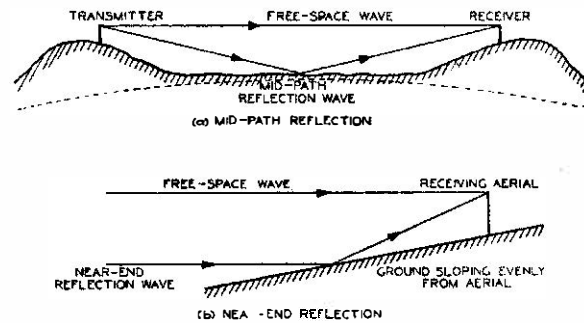

FIG. 2.—PROPAGATION OF FREE-SPACE AND REFLECTED WAVES.

the frequency range under consideration and assuming small angles of elevation at the mid-path reflection, the reflection coefficient can approximate to unity with a phase change of  $180^\circ$ . The power gain due to the reception of the two waves is dependent on the effectiveness of the reflection and on the difference in path length of the direct and reflected waves, and although a theoretical power gain of four is possible, in practice the gain is usually less than two. Similarly, power gains up to four, relative to free-space transmission, can be realised theoretically at both transmitting and receiving terminals by exploiting reflections immediately in front of the respective aerials as detailed in Fig. 2 (b). Here again, however, a more practicable figure is one to two. The efficiency of both mid-path and terminal reflections decreases as the frequency of operation is raised since scattering rather than reflection occurs. In addition, at the higher frequencies, the pronounced directivity of the aerial rejects the locally reflected signals. Nevertheless, it is apparent that, in addition to the provision of aërials sufficiently high above the surrounding terrain to ensure opticality between aërials, it is generally advantageous to adjust the aerial height for optimum signal.

Turning to the question of fading, tests have shown that whereas little fading is experienced on optical links working at the lower end of the frequency band under review, some fading does occur at frequencies above about 1,000 Mc/s which can become very serious on occasion at frequencies approaching 10,000 Mc/s. Also, at the higher frequencies absorption by water vapour, snow, sleet, hail and rain can be very serious. Although, as already stated, there is negligible reflection from the ionosphere of the signals in the frequency band under review, anomalous propagation conditions are sometimes experienced through refraction or reflection on account of irregularities in the refractive index of the atmosphere. At

the higher frequencies the signals may be trapped in a narrow layer of the atmosphere which, acting as a waveguide, transmits the signals over long distances. Anomalous propagation over hundreds, even thousands, of miles has been observed, mainly in tropical areas. Considering radio noise, a general reduction of man-made noise can be expected in the future as the effective suppression of the more noisy electrical devices is achieved. The effect of solar noise can be minimised by the use of very directive aerials. Thus, with reasonable precautions, the planning of systems can be made in terms only of receiver valve and thermal noise.

Turning to aerials, since units large in comparison with one wave-length are practicable (the frequency band 150 to 10,000 Mc/s represents a wave band of 2 metres to 3 cm.), highly directional aerials are available. One common form of directional aerial employs a parabolic reflector to focus the radio waves. It can be shown that for a given size of aerial the power gain increases as the square of the frequency and the beam width varies inversely as the first power of the frequency. Taking a specific example in which the frequency is 3,000 Mc/s ( $\lambda$ , 10 cm.) and the area of the aerial aperture is 9 sq.m., the aerial gain is some 34 db. above that of a half-wave dipole and the beam width is about 3°. If the same reflector is used at 10,000 Mc/s ( $\lambda$ , 3 cm.) the power gain increases to 44 db. and the beam width reduces to 1°. While such a narrow beam width is helpful in restricting trouble due to echo signals and in minimising noise pick-up, it is liable to lead to difficulty in aerial alignment and to occasional loss of gain due to small changes of wave direction caused by variation of atmospheric refractive index. Changes due to this cause of 0.5° are actually experienced. It will be realised from what has been said that a practical upper limit is set to the gain on a link from aerial directivity.

Perhaps the most practical factor influencing choice of frequency is the valve development position. In general, while more or less standard types of valves are satisfactory for frequencies up to a few hundred Mc/s, an upper frequency limit is set by transit-time effect due to the inter-electrode spacing; the less the spacing the higher the upper limit of frequency. Considerable advances have been achieved in this direction, and in the U.S.A. a "close-spaced" triode<sup>7</sup> has been developed which is capable of operation up to some 4,000 Mc/s. It is of interest to note that the grid-cathode spacing of this valve is only 0.0006 in. with a grid-anode spacing of 0.01 in. As a Class A amplifier, it will give a gain up to 10 db. with a bandwidth exceeding 100 Mc/s. No information is available on the valve life and practicability of large-scale production. For frequencies exceeding some 4,000 Mc/s and wide bandwidths it appears that a new type of valve operating on a velocity-modulation principle will be used. This type is known as the travelling-wave valve, and, while very rapid developments have been made, completely satisfactory valves are not yet in large-scale production. Thus, it will be seen that the systems engineer is at present awaiting the provision of completely satisfactory valves before he can utilise fully the possibilities of the higher frequencies. Whatever the type of valve

it is generally true that inherent valve noise, and hence the noise factor of the receiver, increases as the frequency is raised and that the valve efficiency and the radio frequency power output of the transmitter decrease.

Considering now the best actual frequencies of operation of a relay system, it has been stated that the signal-to-noise ratio of a link is inversely proportional to the square of the frequency and directly proportional to the gain product of the two aerials, while the gain of an aerial of constant area is proportional to the square of the frequency. Thus, for aerials of a given size, the signal-to-noise ratio of a link is proportional to the square of the frequency. It would seem, therefore, that the higher the frequency the better the signal-to-noise ratio, but the several other factors already detailed must be considered; thus, fading increases with frequency and full advantage cannot be taken of the narrower beam width of aerials operating at the higher frequencies, absorption occurs at very high frequencies and valve noise increases with frequency while efficiency and radio frequency output both decrease. It will be appreciated from this that there are sound arguments for using frequency allocations in the lower part of the band, 150 to 10,000 Mc/s, for radio-relay systems. In fact, the two U.K. systems utilise frequencies of about 200 and 900 Mc/s, while the U.S.A. systems which have been briefly referred to employ frequencies of about 4,000 Mc/s. It must be envisaged that as the frequency allocations for radio-relay systems in the lower part of the range, 150 to 10,000 Mc/s, are taken up it will be necessary to take up the higher frequency allocations. Before this can be done, however, there is an urgent need for the development engineer to obtain field experience at these higher frequencies, for which purpose he will require reliable and efficient valves.

#### *Type of Modulation.*

The design of a system is simplified considerably if frequency modulation (F.M.) instead of amplitude modulation (A.M.) is employed. Thus, the F.M. signal is not liable to non-linear distortion due to the curvature of valve characteristics, amplitude variations of the signal field at the receiver are removed effectively by the limiter when the minimum incident field is sufficient to ensure full limiter operation and the transmitter design is facilitated by the constant loading of the F.M. system. Finally, even if the frequency swing of the F.M. transmitter is restricted to that of the maximum modulation frequency, a deviation ratio of one, the system gives an effective improvement of about 10 db. over an A.M. system with the same peak power. Possible disadvantages of F.M. operation are the increased bandwidth required and the greater susceptibility of F.M. systems to the effects of echo signals. However, on balance, the F.M. system is to be preferred, as is exemplified by the U.K. and U.S.A. systems to which reference has been made.

#### *Operational Requirements.*

It is, of course, essential that any radio-relay system carrying commercial traffic shall be designed on the

basis of unattended operation of the intermediate relay stations. A similar consideration also applies to the terminal stations if these are not located at premises holding other equipment for which attended operation is necessary. This proviso emphasises the importance of reliability, which can be achieved only by good design and by the sound engineering of that design. Components, and in particular valves, must be of the long-life type. Reserve equipment which can be instantly switched into circuit from a remote control point if the performance of a working unit deteriorates, must be provided. To meet these requirements an adequate monitoring and supervisory system is essential. This system must not by its complexity introduce additional risks of failure of the link, but it must be able to draw attention at the control point to fault conditions which are likely to impair the operation of the system, and also to change over equipment automatically on the occurrence of a major fault. In short, it should enable an effective control of the system to be maintained at all times.

The ultimate performance of a system under traffic conditions is equally dependent on both the supervisory and traffic circuits; neither can be neglected at the expense of the other, but experience does suggest the very minimum complexity of the former for satisfactory operation.

#### THE LONDON-CASTLETON RADIO-RELAY SYSTEM†

When it was possible early in 1946 to return to a consideration of the radio relaying of television signals, the choice of frequency to be used was much more limited by valves than is the case today. Because of this and of the experience already gained in the design of wideband equipment operating on about 200 Mc/s, consideration was given to setting up an experimental system using frequencies about 200 Mc/s. It was felt that the design of a system including several intermediate relay stations would be considerably simplified by restricting the frequency used to a range at which effective amplification could be achieved without recourse to frequency changing to a lower intermediate frequency. It was, in fact, within the bounds of possibility that a "single frequency" relay system in which each repeater merely acts as a "straight" amplifier, could be developed. The simplicity of such a system as compared with that of a link at which frequency changing is required at each intermediate repeater was fully appreciated, as also was the difficulty of ensuring a sufficiently low level of feedback from transmitter to receiver at an intermediate repeater. Finally, it was decided to set up an experimental "single-frequency" system between London and an existing experimental radio laboratory at Castleton, near Cardiff, to give one-way transmission from London to Castleton, using frequency modulation with a maximum frequency deviation of  $\pm 3$  Mc/s about a mean carrier frequency of 195 Mc/s, the system being designed for the transmission of video signals up to a maximum frequency of 3 Mc/s. Pictures were first sent over the complete system on

† The full description and performance of the link, included in the Paper previously referred to, will be given in the next issue of the Journal.

24th March, 1949, and since then a considerable amount of experimental data on the relaying of video signals has been accumulated, the tests still being in progress.

#### THE LONDON-BIRMINGHAM RADIO-RELAY SYSTEM

Sutton Coldfield, the second television station in this country, was formally opened on 17th December, 1949, thereby extending the television service to the densely populated area of the Midlands. Since the operation of this station is dependent upon an exchange of television programme material with London, the Post Office was called upon to provide the necessary relaying facilities for this purpose. Accordingly, a detailed specification was issued in November, 1946, for the interconnection of London and Birmingham by a relay chain of low-power, unattended radio stations as one of the means of relaying television signals between London and Birmingham; satisfactory transmission of video frequencies up to at least 3 Mc/s being one of the requirements. Another requirement of this specification called for the system to be so designed that, even if the system were to be extended up to some 400 miles or so, there should be no noticeable impairment of the television signals. Tenders were invited from a number of manufacturers, the contract being awarded to the General Electric Co., Ltd., in May, 1947. The specification calls for the provision of a radio link providing for the simultaneous transmission in both directions of the 405-line television signals between Museum exchange, London, and Telephone House, Birmingham. However, it was foreseen at the time of placing the contract that it might not be possible to provide the full two-way installation in time for the opening of the public television service from Sutton Coldfield, and arrangements were, therefore, made for one of the channels to be completed before commencing the installation of the other and for the direction of transmission of this one channel to be reversed at will in less than ten seconds. The service is now in operation on this reversible basis and has been provided by supplying just over 60 per cent. of the complete radio equipment, using aerial systems erected on temporary masts provided by the Post Office and equipment installed in buildings at the foot of the masts for the intermediate repeater stations. Whilst the remainder of this article will deal mainly with the radio system as operating at present on the single-channel reversible basis, an outline of the supervisory equipment and full two-way scheme will also be given.

#### *General Outline of the System.*

Previous mention has been made of an experimental system in which not only do the radio transmissions remain on a single but distinct frequency for each direction of transmission throughout the system, but also one in which each radio repeater station operates as a straight amplifier, without recourse to any lower intermediate frequency in the equipment at the repeater stations for securing the required amplification. In the brief discussion on the system the various advantages and disadvantages of the method adopted were mentioned. In the system which is now

operating between London and Birmingham a rather different solution to the problem of relaying television over long distances has been made; due, in part, to the use of a higher carrier frequency of some 900 Mc/s. Thus, at each repeater station the signals are first reduced from their incoming frequency of about 900 Mc/s to an intermediate frequency of 34 Mc/s, at which frequency the necessary amplification of the incoming signals is readily effected, and then re-transmitted on a frequency differing by 20 Mc/s from the frequency of the incoming signals, thereby reducing considerably the risk of interference between the incoming and outgoing signals at repeater stations. It is important to note that the signals are not demodulated to video frequency, except for monitoring purposes, until the receiving terminal station is reached. By this means, the particular difficulties associated with achieving a high degree of linearity, high order of overall frequency stability and accurate D.C. restoration in modulator and demodulator stages are experienced only at the terminal stations and not at each repeater station. An unusual feature of all the transmitters is the use of a frequency changer at the output stage. Only two radio frequencies are required for each direction of transmission, the transmissions alternating from one to the other frequency in successive links throughout the system; the process is illustrated schematically in Fig. 3.

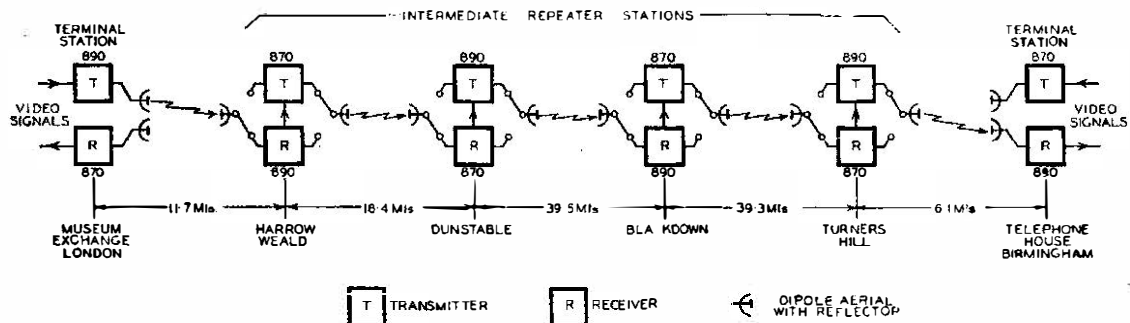

FIG. 3.—SCHEMATIC DIAGRAM OF LONDON-BIRMINGHAM SYSTEM, SHOWING REVERSING SWITCHES SET FOR TRANSMISSION LONDON TO BIRMINGHAM (NUMBERS AGAINST T AND R ARE FREQUENCIES IN Mc/s).

Separate but identically similar aerial systems are used for transmission and reception but both aerial systems are mounted at the top of a common mast, some 100 ft. in height. Each aerial system consists of a paraboloid reflector formed from light alloy tubes, having at its focus a coaxial line fed, horizontal dipole with its associated parasitic reflector; 10 W of radio frequency power being fed into the transmitting dipole. The full diameter of the paraboloid is 14 ft., but its horizontal aperture has been cut to 10 ft. with very little resulting loss of gain. Provision has been made for heating both the dipole head and the tubes forming the reflecting surface of the parabola to prevent the accumulation of ice; up to 6 kW of heating is required for this purpose. The gain of the aerial is 27.5 db. with reference to that of a half-wave dipole, the beam width in the horizontal plane is  $\pm 5.5^\circ$  at half amplitude, and the amplitude of the first side-lobe is less than 10 per cent. of that of the main lobe.

The route of the radio-relay system between London and Birmingham is shown in Fig. 4. Although

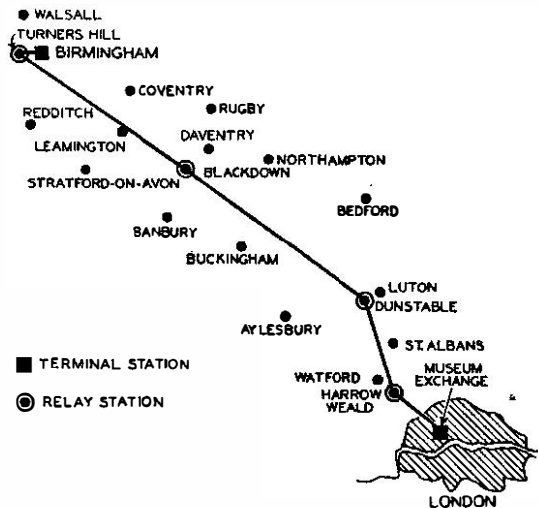

FIG. 4.—ROUTE OF LONDON-BIRMINGHAM TELEVISION LINK.

each station has to be in sight of those on either side of it, only four intermediate repeater stations have had to be provided. Only one site is required at each

repeater station, equipment being installed in buildings at the foot of the single mast used for mounting the aerials (Fig. 5). The sites were, of course, only chosen after an extensive series of trials and in the final choice many factors, other than merely technical factors, had to be taken into consideration, e.g., the preservation of amenities. It will be realised that effective use has been made of natural features, such as the Elstree ridge just north of London, the Chiltern Hills, the Cotswolds, and the high land to the west of Birmingham. The sites have been chosen so that with a maximum aerial height of 175 ft. above ground level, there are clear optical transmission paths between successive stations. This is well illustrated in Fig. 6.

The terminal stations are located in Museum telephone exchange, London, and Telephone House, Birmingham, and, incidentally, the highest aerials are in use at these two stations, the highest parts of the towers being 167 and 196 ft. above street level at

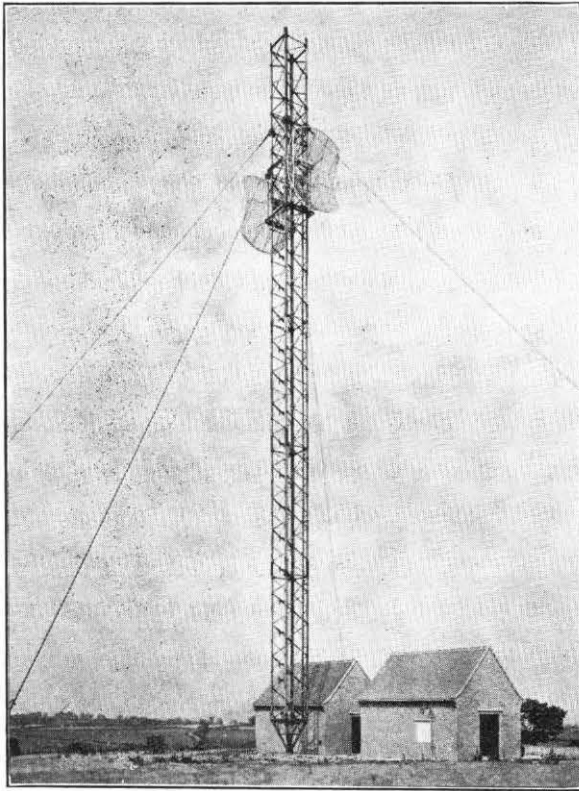

FIG. 5.—THE MAST AND BUILDINGS AT A REPEATER STATION.

used to frequency-modulate an oscillator between 32.5 and 35.5 Mc/s and then this modulated oscillation is amplified and applied, together with the 40-W output of a 900-Mc/s generating chain, to the final stage of the transmitter, which is a frequency changer, the process being outlined in Fig. 8. In this frequency-changer stage, frequencies are produced which differ from that of the radio-frequency generating chain by amounts equal to the frequency of the modulated oscillation. Both these signals, the frequency of one of which is above and the other below that of the radio-frequency generating chain, are frequency-modulated by the vision frequency signal to the same extent as was the original 34-Mc/s oscillator. One of these frequency-modulated sidebands is selected by a filter in the output circuit for transmission, and fed by means of a coaxial feeder to the transmitting aerial; the output power being some 5 to 10 W. The bandwidth of the transmitter frequency-changer and of the transmitter intermediate-frequency amplifier considered together is  $\pm 4.5$  Mc/s at 1.5 db. down.

The F.M. oscillator consists, in principle, of two valves feeding a common anode circuit, flatly tuned to 34 Mc/s, each valve having a feedback path between its grid and the common anode circuit (Fig. 9). The frequency of oscillation is primarily determined by the lengths of the coaxial lines included in the feedback paths. The feedback is applied from the anode through a cathode follower stage, the cathode output of which is connected to the grid circuits of the oscillator valves through a coaxial line so arranged that the electrical length of the coaxial line, at 34 Mc/s,

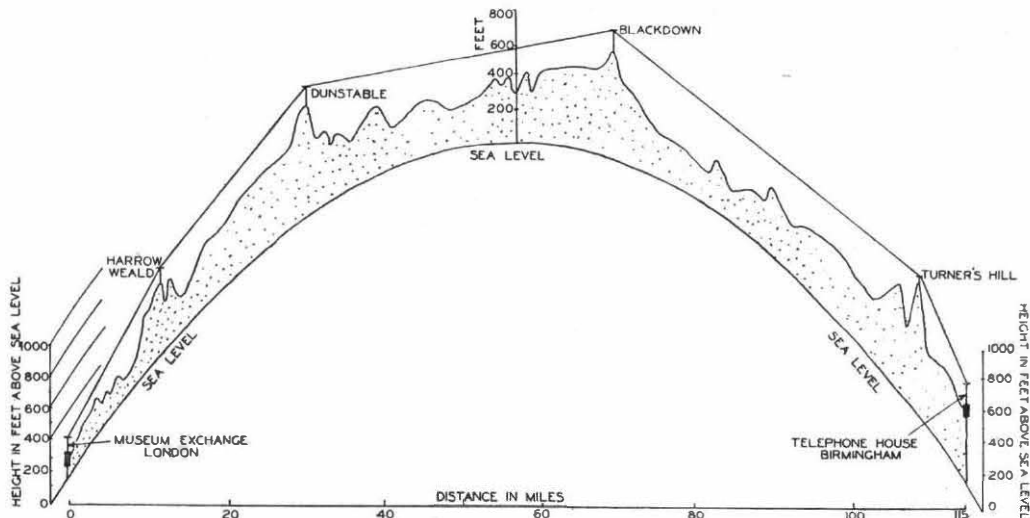

FIG. 6.—PROFILE OF ROUTE LONDON TO BIRMINGHAM (PLOTTED WITH EARTH REPRESENTED AS SECTION OF PARABOLA SO THAT OPTICAL PATHS CAN BE REPRESENTED BY STRAIGHT LINES).

London and Birmingham respectively. The tower at Museum exchange, with its two paraboloid aerial systems, is shown in Fig. 7.

#### Equipment at the Terminal Stations.

The signals to be relayed are fed from the appropriate centre to the terminal station of the London-Birmingham radio-relay link by means of a coaxial cable,<sup>8</sup> thus providing a video signal for modulating the transmitter. The video frequency signal is first

is  $\frac{3}{8}$  wavelength for one valve and  $\frac{5}{8}$  wavelength for the other. In the absence of a vision signal, this circuit will oscillate at 34 Mc/s, as the following consideration of the phase relationships shows. An oscillation at 34 Mc/s, applied round the feedback paths, will produce equal inputs in phase quadrature at the grids of the oscillator valves, since the coaxial lines differ in length by  $\frac{1}{4}$  wavelength. The outputs from the two oscillator valves will also be of equal magnitude and in quadrature phase relationship,

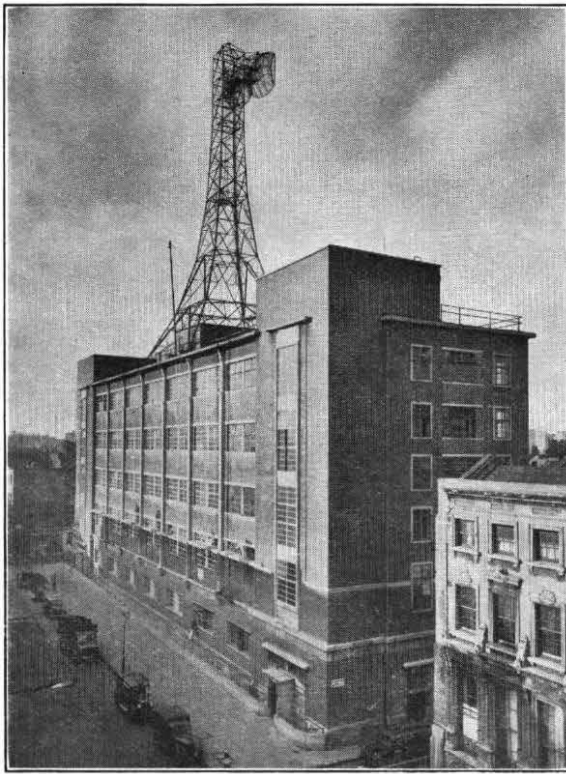

FIG. 7.—THE TOWER AT MUSEUM EXCHANGE, LONDON.

and it will readily be seen, from a consideration of the phase shifts round the feedback path, that the resultant output is in phase with the oscillation

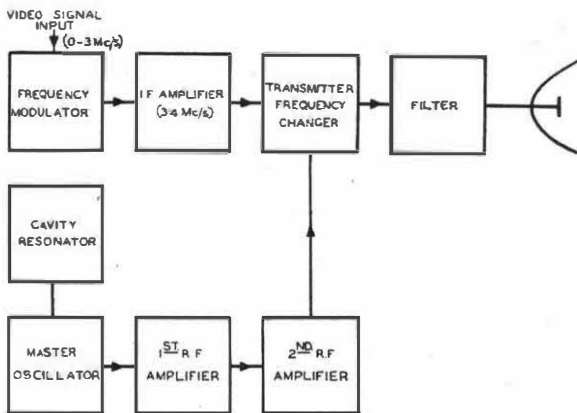

FIG. 8.—BLOCK SCHEMATIC OF TERMINAL TRANSMITTER.

originally postulated; thus oscillation will be maintained at a frequency of 34 Mc/s. When a vision signal is applied, potentials of opposite polarity are impressed on the grids of the two oscillator valves, so that the output due to one of the valves is increased while that due to the other is reduced. These amplitude changes of the two outputs produce a change of phase in their resultant and oscillation can no longer be maintained at 34 Mc/s. The frequency of the oscillator, therefore, alters, and with it the electrical lengths of the coaxial lines, until, at some new frequency, the phase relationships are again

appropriate to maintain oscillation. In this way, the amplitude variations of the vision signal are converted to frequency-modulation of the 34-Mc/s carrier, with

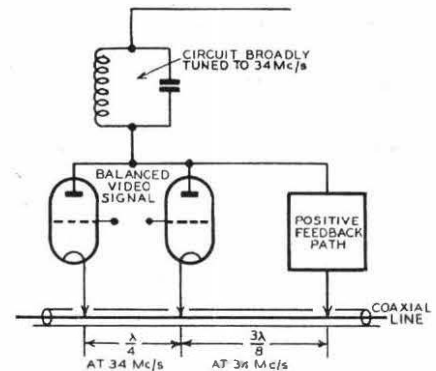

FIG. 9.—SCHEMATIC DIAGRAM OF F.M. OSCILLATOR.

a high degree of linearity. The instantaneous output frequency during the intervals corresponding to the transmission of synchronising pulses is automatically stabilised with reference to a crystal-controlled source.

It will be appreciated that the equipment used in this system necessarily makes use of advanced techniques in valve and circuit design because of the high radio frequency at which it is operating. The radio-frequency equipment is based upon the use of disc-seal triodes and coaxial-line circuits. Each radio-frequency-tuned circuit is essentially a length of coaxial transmission line. The general finish of the radio-frequency circuits is silver plate and a rhodium flash. Air cooling is used in the higher power stages of the transmitter.

The frequency stability throughout the complete system is essentially due to that of the master oscillator at the terminal transmitting station, and since its construction also illustrates the coaxial-line technique, a description of this unit will serve to illustrate the general nature of the design of such high-frequency equipment. A schematic of the circuit arrangement is shown in Fig. 10. The master

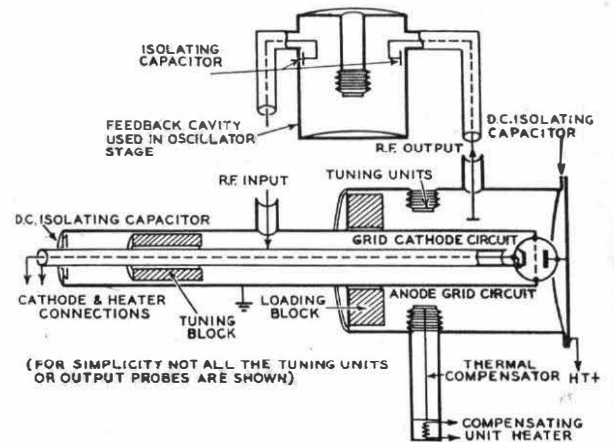

FIG. 10.—MASTER OSCILLATOR (AND 1ST. R.F. AMPLIFIER) SCHEMATIC ARRANGEMENT.



oscillator operates in the 900-Mc/s band, and no frequency multiplication is required in any chain associated with it. The valve used is a disc-seal triode, with a coaxial line connected between the grid and the anode, and another coaxial line connected between the grid and the cathode. The mechanical arrangement is such that these two circuits are themselves coaxial, one of the tubes forming the inner conductor of one circuit and the outer conductor of the other. The anode-grid circuit operates in a three-quarter wavelength mode of resonance with the grid-cathode circuit approximately one and three-quarters of a wavelength long. The heater connection is coaxial with the inner conductor of the grid-cathode line, and is not subjected to any radio-frequency field. Oscillation is maintained by a feedback path, external to the two circuits, which is arranged to include a resonant cavity. Feedback, and therefore oscillation, can only occur at the frequency to which the cavity is tuned. Variations due to temperature changes are minimised by a temperature-sensitive bi-metallic device acting on a bellows tuning unit attached to the outer conductor of the anode-grid circuit. It is of interest to note that the radio-frequency output of the master oscillator is some 4 W, obtained at a D.C. anode efficiency of 22 per cent.

For reception at a terminal station, the received signal is heterodyned by a local oscillator, of the same design as the master oscillator, to give a difference frequency of 34 Mc/s, a silicon crystal being used as frequency-changer. The receiver intermediate-frequency amplifier consists of two stages, each using a pair of low-noise triodes, followed by three automatic gain-controlled stages, each using a pair of pentodes, and two further stages using pairs of pentodes and a cathode-follower output stage. Even if one of the pair of valves used in each stage fails, the amplifier will still continue to work satisfactorily. The action of the automatic gain control is such that a change in intermediate frequency input level of 20 db. is reduced to a change of 0.5 db. in the intermediate-frequency output level. At an intermediate station, this intermediate-frequency output then passes first to higher power intermediate-frequency amplifiers and then to the transmitter-frequency translation stage, as described in the following section, whereas at a terminal station this intermediate-frequency output passes to the terminal demodulators.

The demodulator units include limiters, the discriminator stages and video-frequency amplifiers. Demodulation is achieved by a conventional form of discriminator consisting of two tuned circuits, one tuned above and the other tuned below the intermediate-frequency mid-band frequency. In the interests of stability and linearity, however, conventional lumped circuits are not used but instead, coiled-up sections of coaxial cable are used, end-loaded with small variable capacitors, simulating end-loaded transmission lines. The output vision signal is then passed through amplifiers to the cable-terminated equipment at video frequency.

Fig. 11 is a photograph showing the receivers, waveform and picture monitors and transmitters at the Museum Terminal.

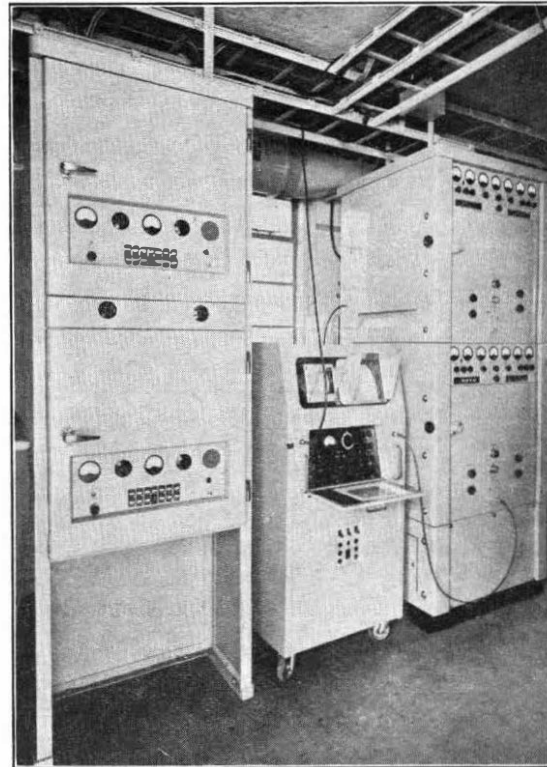
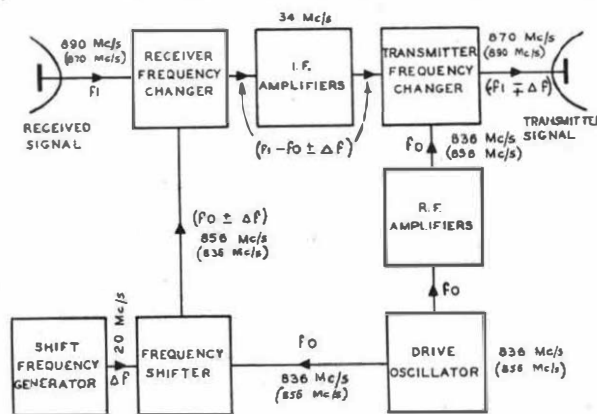

FIG. 11.—RECEIVERS, MONITORS AND TRANSMITTERS AT MUSEUM TERMINAL.

#### Equipment at the Intermediate Repeater Stations.

A schematic diagram of the arrangement and equipment in use at a repeater station is given in Fig. 12. It has been pointed out that the frequency on which the signals are re-transmitted at an intermediate repeater station is not the same as the received frequency, differing by 20 Mc/s, thereby



NOTE —  $\Delta f = 20 \text{ Mc/s}$

FIG. 12.—ARRANGEMENT OF FREQUENCIES AT A REPEATER STATION (FREQUENCIES IN SMALLER PRINT, IN BRACKETS, ARE ALTERNATIVES).

reducing considerably the risk of receiving power from the local transmitter as well as from the previous station. To achieve the frequency translation, the frequency of the local oscillator of the receiver differs from that of the transmitter drive oscillator. From

the point of view of overall frequency stability, it is convenient to derive the local oscillator frequency from the transmitter drive oscillator. This is accomplished by mixing an output from the drive oscillator with that from a crystal-controlled oscillator whose frequency is equal to the difference between the received and transmitted frequencies, i.e., 20 Mc/s. Thus, the transmitted frequency is made independent of the drift of the station drive oscillator and is affected only by the small drift of the crystal-controlled 20-Mc/s oscillator. Since only two frequencies are used for a channel in either direction, the "shift" frequency is the same at all repeater stations, and is alternately added to or subtracted from the station drive oscillator frequency. By this process, the frequency transmitted from all repeater stations is governed by the received frequency only, subject to the small drift of the 20-Mc/s crystal-controlled oscillators, and the transmitting frequencies throughout a channel are, therefore, effectively controlled by the master oscillator at the transmitting terminal. The design of the drive oscillator is the same as that of the terminal master oscillator.

The actual transmitting and receiving equipments (Fig. 13) used at the repeater station are basically the

switch arrangement which changes the capacitance in a series resonant circuit shunted across a suitable stub connection. As has already been stated, two frequencies only are used, alternately, for the transmitters of the channel. The spacing of these frequencies has been chosen to reduce to a minimum the possibilities of second-channel interference, crosstalk between channels, and the effects of all the possible combinations of unwanted frequencies generated in a repeater station. The arrangement is illustrated in Figs. 3 and 14.

#### Miscellaneous Features.

Reliability of service is essential and considerable attention has been paid to this requirement in the design of the equipment and provision of spare facilities. Thus, duplicate signal-channel equipment and power units with changeover switching are provided to maintain the operation of the link in the event of a failure of the working equipment. The equipment, which is not in use, is kept warmed up in a standby condition, so that it is ready for immediate operation. The aerial system and transmitter output filters are not duplicated, and, therefore, a radio-frequency switch has been provided in the output

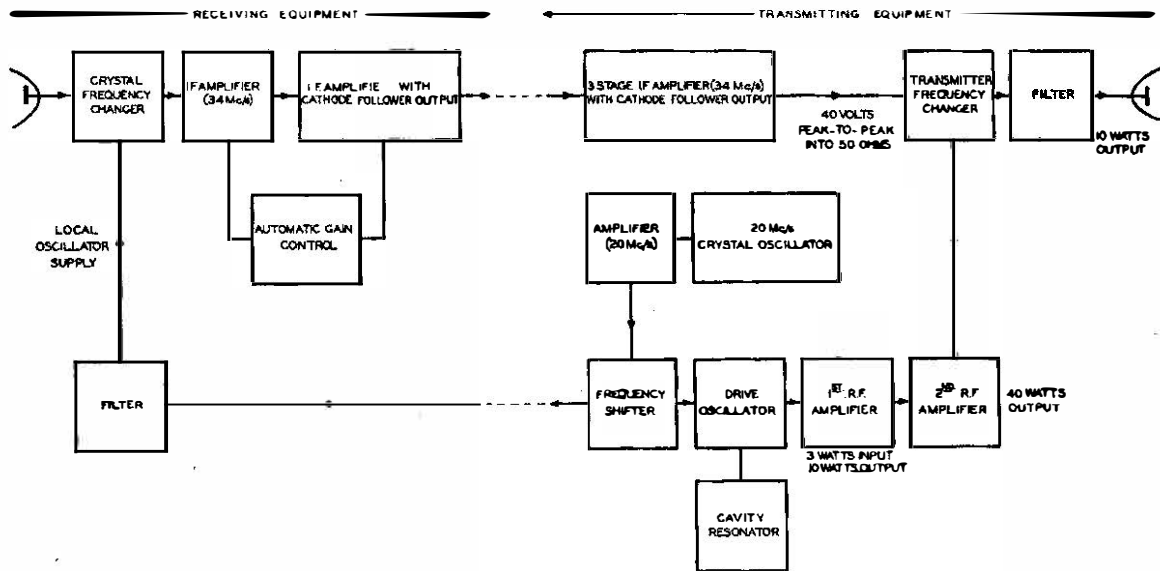

FIG. 13.—BLOCK SCHEMATIC OF REPEATER STATION EQUIPMENT.

same in design as those at the terminal stations, but, of course, the signals being relayed are not demodulated to video frequency until the receiving terminal station is reached. It is of interest to note that the received power for free-space propagation between the paraboloid aerials, over the 40-mile path, is about one microwatt, and since the transmitted power used at each station is some 10 W, the gain required from the equipment (excluding aerials) in such a repeater station is about 70 db.

For the reversible link, now being operated, only two aerials are provided at each repeater station, and since the transmitter and receiver are both connected to each aerial, there is a physical path from transmitter to receiver. The change of direction of transmission is produced by the operation of a contactless

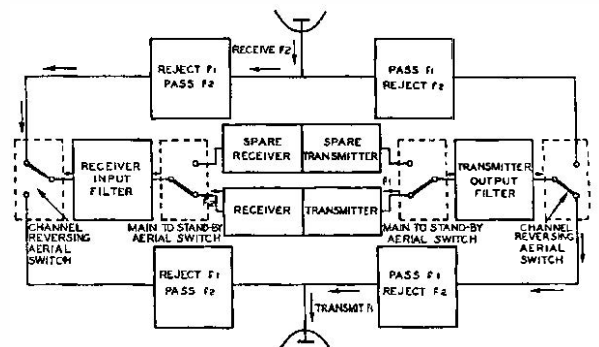

FIG. 14.—ARRANGEMENT OF RESONANT-TEE FILTERS AT A REPEATER STATION TRANSMITTING ON FREQUENCY  $f_1$  AND RECEIVING ON FREQUENCY  $f_2$ .

feeder between each main and standby transmitter and the common output filter. Similar switching and filtering is provided at the input of the associated receiver. Changeover switching between the power units and the signal-channel equipment is so arranged that each channel equipment can be connected to either power unit. The power is normally taken from a public supply, but in the event of a mains failure a 15-kW diesel alternator starts up automatically.

Economic provision of radio-relaying facilities can only be made if the equipment can be operated on an unattended basis with only occasional visits from maintenance staff. The radio system can be fully controlled from either control point, i.e., London (Museum exchange) or Birmingham (Telephone House). Fault monitoring is provided on the units of the equipment and the fault indications are transmitted by a voice-frequency signalling system to the appropriate control point over a four-wire line. This signalling system also conveys the control signals from the control point to the radio stations. Only the essential controls are at present in operation, but eventually the fault indications given at the control point for each radio station will include information on whether the station is working, which channel equipment and power unit have been selected, and the occurrence of a fault and consequent automatic change-over in the equipment. Indication will also be given as to whether the mains supply to the station is on and, in the case of a repeater station, whether the standby generator is working. A fault on the supervisory system will also be indicated at the control point. The system differentiates between major and minor faults and only provides for automatic change-over on major faults. The equipment at all stations can be switched on and off from the control point and a changeover made between working and standby units. If the supervisory system fails to switch on the equipment at the various stations, the stations come into operation on pre-set time switching.

#### *Performance of the System.*

Since the system, although in daily operation on a reversible basis, has not yet been completed by the contractor and, in fact, even the aerials are not mounted at heights which will be used when the towers become available, it is too early to give full details of the performance. Suffice it to say that there is every indication that when all the equipment for the full two-way system is installed, the system will comply with all the main performance requirements specified and detailed earlier in this article. However, the photographs (Figs. 15 and 16), which show signals actually transmitted over the system, will give some idea of the present performance.

#### *The Two-way Installation.*

The conversion of the system from one-way reversible to full two-way operation is necessarily a gradual process and great care has to be taken to ensure that the reliability of the present service is not impaired in the process. The final repeater station towers are now being erected and in due course all the radio equipment will be installed in special cabins at

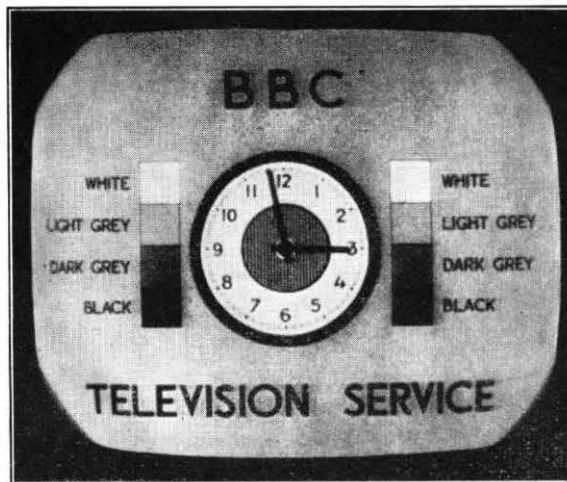

FIG. 15.—TUNING SIGNAL AS RECEIVED AT SUTTON COLDFIELD.

the tops of these towers—see Fig. 17, which is a photograph of a model of the towers. This will eliminate the losses in the present feeders between the aerial systems and buildings, and avoid any possibility of troublesome echoes from mismatch of the aerial and feeder systems. It is estimated that an improvement of as much as 12 db. in the signal-to-noise ratio will



FIG. 16.—PICTURE OF ANNOUNCER AS RECEIVED OVER THE SYSTEM.

result from these changes. The reversibility feature for the existing channel will not be retained when the system is finally completed. An additional pair of frequencies will be used for the second channel, the general arrangement of the full two-way system being shown in Fig. 18.

#### THE FUTURE

It will be appreciated that the long-distance relaying of television signals is still in its early stages and that it is not an easy matter to specify, in the necessary detail, the performance requirements which must be met for the individual systems involved in the relaying over long distances of such signals. Soon,

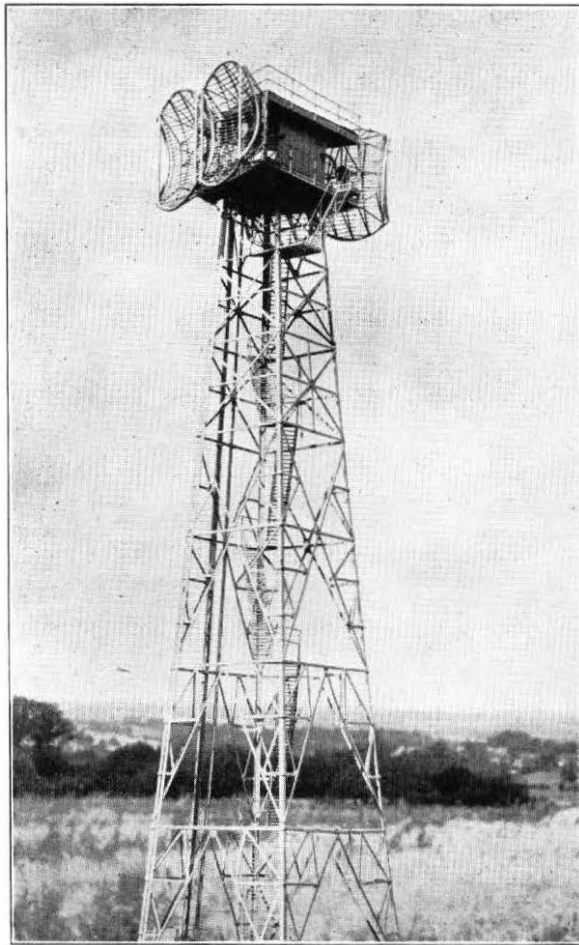

FIG. 17.—MODEL OF REPEATER STATION TOWERS.

practical comparisons of the relaying of television signals by radio and by coaxial cable will become possible in this country, but the results of such comparison cannot be awaited before becoming committed to the actual means of provision for further extensions in view of public demand for the expansion of the television service. Thus, the extension of the television service from Birmingham to the Manchester

area will be accomplished by employing coaxial cables ( $\frac{3}{8}$  in. diameter) and the extension from Manchester to Edinburgh will be by radio; thereby commencing the integration of cable and radio-relay systems. Certain it is that with the extension of television to more and more distant places—and some idea of the expansion proposed for this country of the existing 405-line-type signals is given in Fig. 19—the performance required

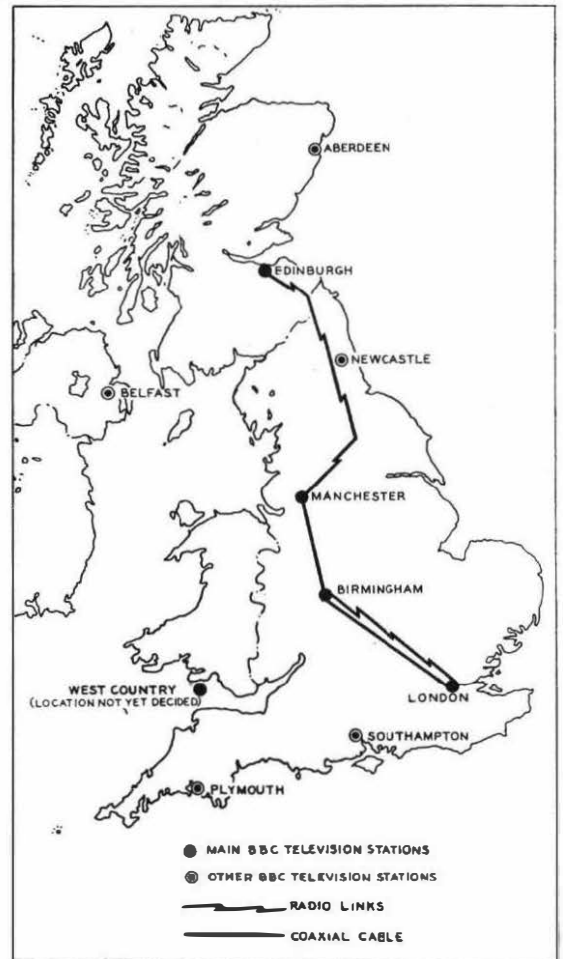

FIG. 19.—EXPANSION OF TELEVISION SERVICE.

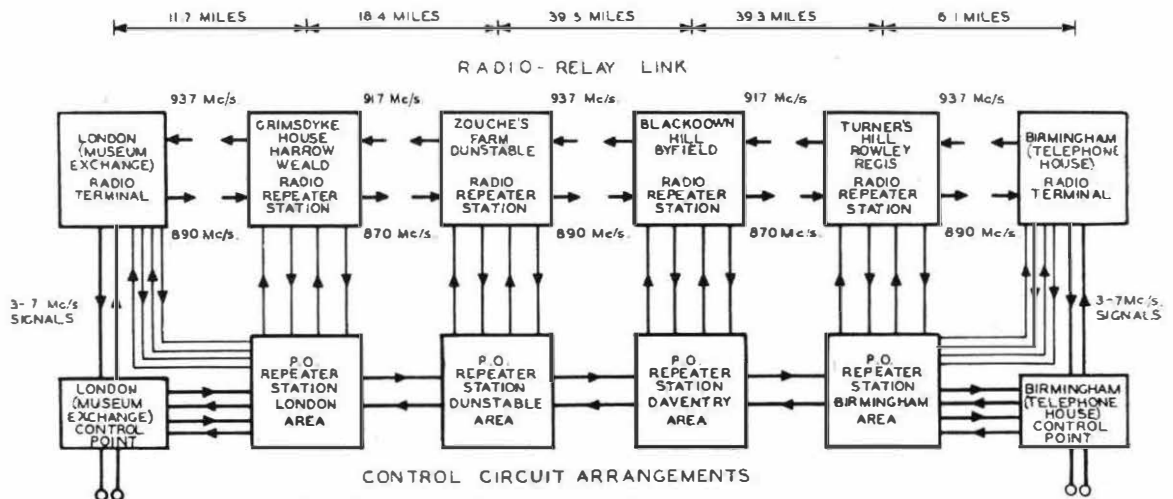

FIG. 18.—BLOCK SCHEMATIC OF FULL TWO-WAY SYSTEM.

from the relay links becomes more and more exacting if the cumulative effects of distortion in the component parts of the overall system are to be kept sufficiently low.

This article has outlined the position of the relaying of the present United Kingdom standard television transmissions. Doubtless at some time in the future a higher definition or, perhaps, colour will be demanded, with a consequent need for the transmission of still wider bands of frequencies to an even more exacting performance specification if the advantage of the higher definition is not to be lost. It seems likely that the advantages of radio will come even more to the fore with the demands for wider transmission bands. If, in the more remote future, the use of still wider frequency bands, maybe several hundred megacycles per second in width, becomes a necessity, it would seem that the waveguide method of transmission in which the signal will be transmitted (or guided) through a hollow metal tube, laid in the ground as coaxial cable is today, will be required. It will be apparent from what has already been said that the radio-relaying of wideband signals, whether using highly directional antennae and free-space transmission or using waveguide transmission, is destined to play an important part in the future.

#### *Acknowledgments.*

The development, production and installation of the London-Birmingham radio-relay system has been carried through by the General Electric Co., to whom we are indebted for much of the information contained in the brief description of the link.

We also wish to thank those many members of the Regional staff who have co-operated so willingly in helping our projects forward in so many different ways, appreciating as we do that the equipment for modern trunk systems is becoming so increasingly complex, whether or not the systems are radio, that they present a serious maintenance problem to the Regional staff.

Finally, we express our grateful thanks to our many colleagues in the Radio Branches whose efforts have contributed to the successful introduction of the television radio-relay link.

#### *Bibliography.*

<sup>1</sup> "A Micro-wave Relay System Between New York and Boston," A. L. Durkee, *Bell Laboratories Record*, December, 1947.

<sup>2</sup> "Terminals for the New York-Boston Radio-Relay System," J. G. Chaffee, *Bell Laboratories Record*, March, 1949.

<sup>3</sup> "New York-Boston Microwave Television Relay," *Electronics*, January, 1948.

<sup>4</sup> "A Broad-band Microwave Relay System Between New York and Boston," G. N. Thayer, A. A. Roetken, R. W. Friis and A. L. Durkee, *Proceedings I.R.E.*, February, 1949.

<sup>5</sup> "The Marconi-E.M.I. Television System," A. D. Blumlein, C. O. Browne, N. E. Davis and E. Green, *Journal I.E.E.* (Proceedings of Wireless Section), 1939, Vol. 14, No. 40, p. 65.

<sup>6</sup> "The Effect of Noise and Interfering Signals on Television Transmission," R. F. J. Jarvis and E. C. H. Seaman, *P.O.E.E.J.*, October, 1939, Vol. 32, p. 193.

<sup>7</sup> "A Microwave Triode for Radio Relay," J. A. Morton, *Bell Laboratories Record*, May, 1949.

<sup>8</sup> "The London-Birmingham Television Cable," H. Stanesby and W. K. Weston, *P.O.E.E.J.*, January and April, 1949, Vols. 41, p. 183 and 42, p. 33.

---

## Book Review

"The Principles of Scientific Research." Paul Freedman, B.Sc., M.I.E.E., F.I.E.S. Macdonald & Co. (Publishers), Ltd., London. 222 pp. 11 ill. 15s.

The word "science" can have various meanings, yet it is evident that possession of knowledge is, by itself, no indication of that capacity for original thought which is an essential for successful scientific research. The author of this book is careful to give reasoned definitions of the meanings he gives to the words "science" and "scientific research" in the introductory part, which occupies the first three chapters. Taken as a whole, these chapters (60 pp.), outline influences of society and philosophy on scientific research, covering the whole span of recorded history and many branches of science. This remarkable feat of condensation is achieved by allowing the essential historical record to run through and by interspersing it with comment to bring out the points the author most wishes to make. It is interesting to note that the landmarks in the history of the methods of scientific research are not necessarily the same as those in the more familiar history of the product, scientific knowledge. A nice sense of proportion is maintained throughout the book and we share the author's regret that in consequence, the historical introduction cannot be given more space.

The remaining chapters contain advice and information concerning scientific research, primarily written for those who are inexperienced. Aspects covered include the

personal qualities most likely to lead to success and lines on which these qualities should be developed and applied; the planning of research in relation to the nature of the problem and the resources and time available; use of the different senses for observations; choice of equipment; the strengths and weaknesses of team-work; relations between senior and junior scientists and between scientists and others concerned in their work (there is a chapter devoted to Patrons of Research); and accuracy of observations and economy of effort, related to which is a special mention of techniques for designing experiments so that the number of essential observations made is a minimum.

The underlying principles, which are the theme of the book could, when generalised to apply to the whole varied field of problems in scientific research, easily appear vague and unsatisfying. As treated, however, they are so well supported by the author's comment and explanation and illustrated by examples, mostly from his own experience, that the book is very readable. It should be read not only by those for whom it is primarily intended, namely young men and women embarking on research, but also by their more experienced colleagues and by those who have financial or administrative control of scientific researches. It is also worthy of notice by others who are interested in the capacity for thinking objectively in other fields of human activity.

W. W.

# Testing Facilities in H.M.T.S. Monarch

P. R. BRAY, M.Sc.(Eng.), A.M.I.E.E.

U.D.C. 621.315.28

For the wide range of submarine cable work undertaken by the *Monarch*, comprehensive testing equipment and associated power supplies are necessary, together with test leads and intercommunication facilities so as to allow for tests to be conducted and controlled from a suitably situated testing room. In this article the author describes the equipment and testing facilities in some detail and outlines possible future developments in submarine cable testing technique.

## Introduction.

SINCE H.M.T.S. *Monarch* was fitted out, experience gained in various aspects of deep-sea telegraph cable laying and repairing has led to modifications in the testing-room apparatus and circuits. That the modifications have, in general, been of a minor nature is a sufficient indication of the excellence of the original installation.<sup>1</sup>

In this article a description is given of the testing facilities as they are at present, without detailing the alterations that have been made, but it may perhaps be mentioned that the largest single change on the D.C. side is the provision of a guarding system, and in the A.C. bridge equipment certain additions and rearrangements have been made, with an improvement in the 230V A.C. power supply.

## General.

The testing room (Fig. 1), measuring 15 ft. × 16 ft., is situated on the port side at the forward end of the shelter deck, with access from the centre castle and a view of the foredeck. The main test table (Fig. 2), accessible on three sides, is 12 ft. × 5 ft., and on this is mounted all the permanent D.C. apparatus. The A.C. bridge, with associated apparatus, is built up on a narrow bench against the after bulkhead.

The fore part of the room contains a desk, settee, filing cabinet and wash basin. Adequate cupboard space is provided for storing spare equipment and accessories.

## Power Supplies.

The ship's supply is 220V D.C. balanced to earth,

<sup>1</sup> Cable Test Report No. 1327 (restricted circulation).

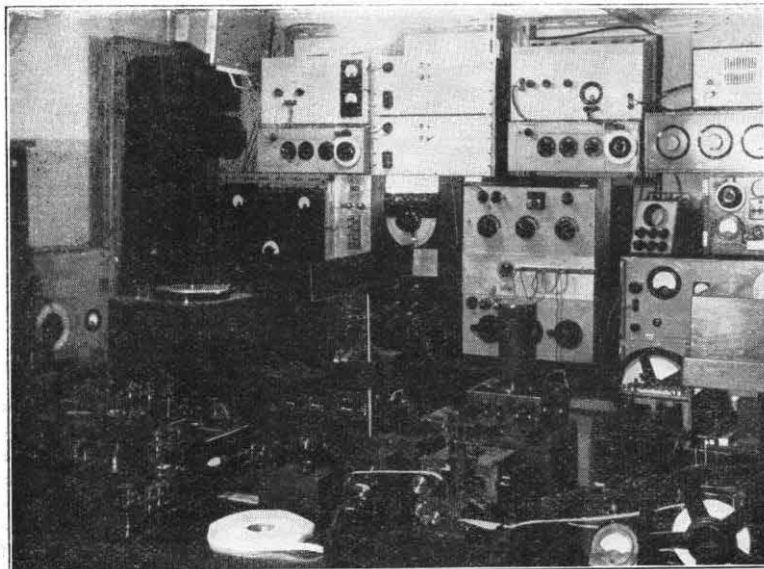

FIG. 1.—GENERAL VIEW OF THE TESTING ROOM.

and an adequate number of points is provided in the testing room. For the battery supplies to the D.C. testing sets, accumulators are used, and these are

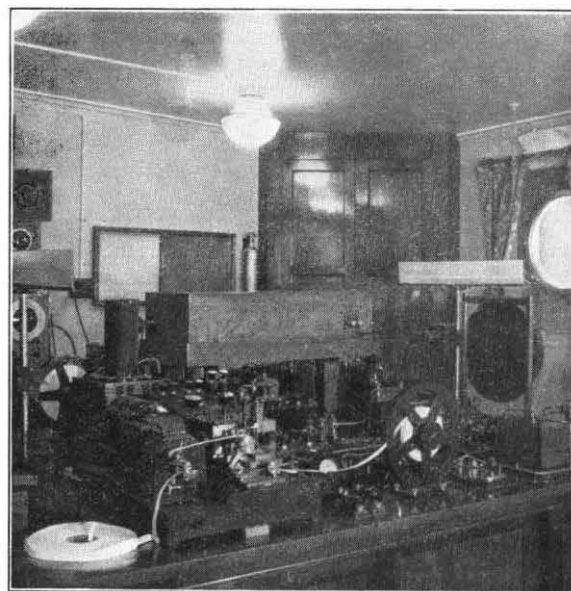

FIG. 2.—THE MAIN TEST TABLE, SHOWING SYPHON RECORDER AND D.R. TEST SET.

charged from the ship's mains in a cupboard adjacent but external to the testing room. Reverse current relays protect the batteries against mains failure.

Two separate motor alternator sets, each of 800 W, provide the 230V A.C. 50 c/s supply needed by the bulk of the A.C. bridge equipment. These sets are housed in the thermo-tank room on the main deck, but apart from isolating switches all the controls are mounted in the testing room. The A.C. output is stabilised against variations on the D.C. side by rectifying a portion of the output and injecting it into the alternator field. Control of the output voltage is also given by means of a variable ratio transformer. Each alternator has its own panel of output sockets and transformer, so that an extra degree of decoupling between high- and low-level mains-driven apparatus can be attained if desired.

## Intercommunication Facilities.

A telephone on the ship's main internal system has five outlets, with push-button selection. These outlets are to the forward and after drum

rooms, the chart room, and to two suites which may be occupied by representatives of concerns chartering the ship. A separate telephone communicates with the bow and stern sheaves.

An audible signal may be made to each of the four cable tanks by means of bell-pushes, and in the reverse direction a bell signal may be received from the tanks, a drop indicator board identifying the tank. This bell system may be used according to any pre-arranged code, to indicate for example that a splice is about to be paid out, or in conjunction with the telephone leads associated with the tank testing leads.

#### *Test Leads.*

Six sets of permanent test leads are provided, connecting the testing room with the forward and after drum rooms, and with test boards adjacent to each of the four cable tanks. Each set consists of eight double-lead-covered rubber-insulated D.C. test leads (150-lb. conductor), two polythene-insulated coaxial cores with centre conductor of 508 lb./n.m. and copper return conductor for A.C. tests, and a 4-core 40-lb. lead-covered cable used chiefly for communication purposes.

At the far end of the leads (i.e., remote from the testing room) each of the D.C. and A.C. test leads terminates in a heavy slotted terminal mounted on an ebonite pillar. The D.C. leads are guarded by brass plates under the pillars, these plates being connected to the intermediate lead sheaths. The outer sheaths are connected together to form the earth return, and this "earth" may be connected to the hull earth as required. The guard system on each set of leads may be isolated from the rest and further sub-divided into two groups, should it be necessary to trace a fault in this system. The screens of the A.C. coaxial leads are brought out separately to terminals closely associated with their appropriate line terminals, in order that connections may be made with the minimum of added inductance.

Two flexible double-screened polythene coaxial leads are employed for connecting from any terminal board to the end of a cable. These leads are used chiefly on the foredeck, to connect cable to the forward drum-room, particularly for tests just prior to a final splice. Similar type leads have been run from the testing room to cable tanks 1, 2 and 3, 4 (shared). These were installed before the guard system had been instituted on the normal test leads, at a time when it was necessary to make insulation tests on a long length of polythene cable with very high intrinsic insulation resistance. They will be useful in the future should it be necessary to make tests at high voltage.

In the testing room, all the sets of normal testing leads and the four-core leads terminate on a Paxolin panel mounted on the main testing table against the inboard bulkhead. Also connected to jacks on this panel are telephone leads from the Senior Testing Officer's cabin and from that of the Leading Joiner. The test board thus provides facilities for connecting up a Telephone "F" in the testing room with other parts of the ship, and also for inter-connecting these places.

As with the terminal boards at the far ends of the leads, two earth terminals (outer sheaths of D.C. leads and the ship's hull) are provided. In addition, a guarded "line" terminal and "low potential" terminal are mounted on the board. The former is connected to the guarded line lead on the testing table, and may be joined to any terminal on the board by means of a flexible guarded lead. The latter is connected to the conductor resistance test set on the table, and may also be connected to any terminal on the board through a flexible lead. Except for loop C.R. tests on tank cable, it is normally connected to earth.

The line lead on the testing table is connected to a series of pillar-mounted sockets, each pillar being guarded. Any particular piece of equipment on the table may be connected to line by inserting a "petticoat" type plug in the appropriate socket. As only one plug is employed it is very unlikely that one test set would inadvertently be connected to line at the same time as another.

### THE CONDUCTOR RESISTANCE TEST SET

#### *General Considerations.*

Fig. 3 is a schematic diagram of the conductor-resistance test set connections. Basically it is a precision 5-dial Wheatstone bridge (thousands to tenths) suitably adapted for the particular nature of submarine cable testing, one of the main requirements being that the testing current should be easily controlled and set. This feature is considered later.

The line is connected to the bridge either directly or through a centre-zero milliammeter (30-0-30), with or without an added resistance, R4. This resistance is used in "overlap" tests when a cable is faulty but not broken. Switch S2 earths the line when the shore station is required to make a C.R. test to the ship. Normally the "low potential" lead is earthed when making single-ended tests, but it may be connected to the other end of the conductor when both ends of the cable are available in the ship, as in the loop tests on stock cable. Should a fault occur in a long length of such cable, S1 is used to earth the battery for a Varley test.

The bridge normally reads in International ohms, but an additional ratio arm has been provided in B.A. ohms\* to give direct answers in these units if desired, the records of some cable systems being based on B.A. ohms.

#### *Galvanometers.*

Two galvanometers are permanently wired to the bridge via the galvanometer key, which short-circuits one when the other is in use. One galvanometer is of the "Unipivot" (pointer) type, with a sensitivity of 1.1 divisions per micro-amp. This is used for obtaining approximate initial balances, for routine C.R. tests when the ship is steady, and for keeping a continuous visual check of balance when picking up to an earth fault. The other galvanometer is more sensitive, being of the reflecting type. The sensitivity of the suspension and coil normally employed in this

\* Resistance in B.A. (British Association) ohms = resistance in International ohms  $\times$  1.0136.

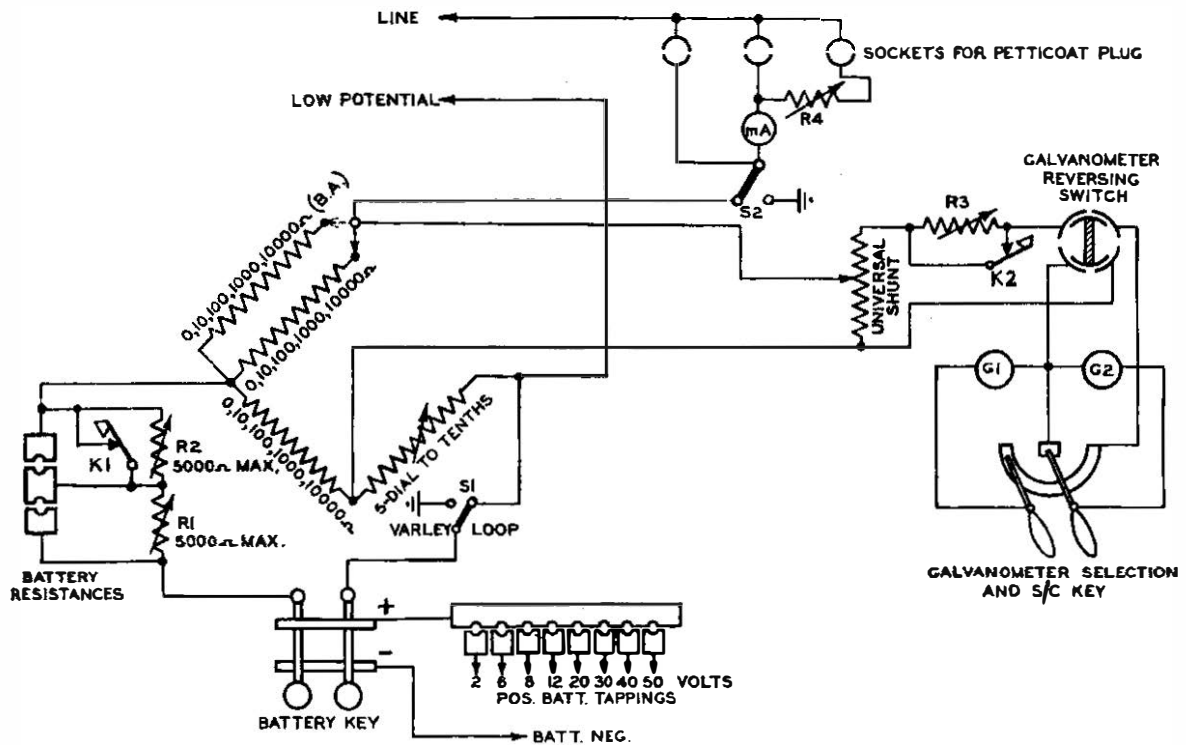

FIG. 3.—CIRCUIT DIAGRAM OF THE CONDUCTOR RESISTANCE TEST SET.

particular instrument is 40 mm. per micro amp. The coil carries small adjustable weights, by means of which the centre of gravity of the coil assembly may be brought exactly in line with the suspension. This ensures that there will be no appreciable rotation of the coil relative to the pole pieces when the ship rolls or pitches. Another important feature of this galvanometer is the wide range of control on the torsion head, which is used extensively in testing to False Zero or in Break tests as described below.

#### False Zero (or Cable Zero) Test.

When measuring the resistance of a single conductor, with one end only available at the testing station, it is necessary to use the earth as a return conductor. With the earth as part of the loop, it is at once apparent that any potential difference existing along the earth circuit will have an effect on the measuring bridge. Unfortunately, such P.D.s do exist, and they may be due to induced E.M.F.s in water moving relative to the earth's magnetic field, to interference from other neighbouring electrical circuits, or to magnetic disturbances. Spasmodic variations in the P.D. have to be tolerated, testing being carried out if possible in the quiet intervals, but the steadier components may be allowed for by observing their effect on the galvanometer deflection, and adjusting the bridge measuring resistance accordingly. Thus, at false zero balance, the deflection is the same whether the testing battery is applied or not.

It is important that the resistance of the network, as seen from the line, should not differ with the change in the battery conditions, and for this reason it is preferred that the resistors R1 and R2 used for controlling the testing current be connected on the

bridge side of the battery key, so that they remain in circuit. It will be noted that in the false zero condition (i.e., battery key not operated) the low resistance battery is replaced by a direct connection, not a disconnection.

It may be found that the reflected spot of light moves off the scale under the influence of the earth P.D.s even with the galvanometer well shunted. As this would lead to an insensitive measurement, the torsion head is operated to bring the spot back on the scale as balance is approached, with the shunt opened up to full sensitivity if necessary. The electrical zero used in balancing may thus be very different from the mechanical or scale zero of the galvanometer. When testing a long line, it is not desirable that the galvanometer should be subject to the changes of charge brought about by the operations of the battery key, and it is short-circuited during such operations. It may sometimes occur that even so the galvanometer has to tolerate quite a violent change of conditions, owing to a big difference between the mechanical and electrical zeros. In such a case the short-circuiting of the galvanometer may be replaced by the opening of key K2, which puts the resistance R3 in series with it. Adjustment of R3 may be made to give a compromise between the two unwanted effects. Whether it is better to use R3 or the short-circuiting key depends on the circumstances, particularly with regard to the effect of galvanometer damping.

#### Testing to a Break.

When the copper conductor is exposed to sea water, it forms a cell with the iron of the armouring wires, the open circuit E.M.F. being about 0.5 V, with the copper positive. This cell polarises when current is



taken from it, so that its E.M.F. is not constant. Also, electrolysis takes place when current is passed through the cell, and the resistance so caused is dependent both on the strength and on the direction of the current.<sup>2</sup>

In order to measure the resistance of the conductor to a break it is necessary, therefore, not only to allow for any earth P.D.s and the E.M.F. at the fault, but also to eliminate the fault resistance from the value obtained on the bridge. Various tests have been devised with this latter object in view, all being based on the assumption that the variation of fault resistance with current may be determined. Resistors R1 and R2 are employed to give control of the current to line. The key K1 across R2 enables the current to be changed quickly from one value to another, and when so employed, with the battery key left down, results in a form of test called "reduced current zero." This is, in effect, a controlled false zero and, strictly speaking, the effect of the line voltages is different in the two positions of K1, owing to the change of resistance involved, but the error from this cause is not normally judged to be significant. For faults close to the ship, the resistance R4 is put in series with the line, as it is more convenient to have the bulk of the line resistance invariable with current.

It should be borne in mind that one effect at least, polarisation, is time dependent. Consequently, the electrical zero at which to balance is the position of the light spot after the initial kick due to inductive effects on changing the battery conditions, but before the spot drifts away under the influence of polarisation change.

#### THE INSULATION (DIELECTRIC RESISTANCE) TEST SET

The circuit is shown in Fig. 4. The resistance to earth from the line terminal is measured by comparing the amount of current flowing with that which is passed by a standard resistance (1 megohm). The simple series circuits such as (a) and (b), shown inset

<sup>2</sup> *Munro and Jamieson's Pocket Book*, p. 331.

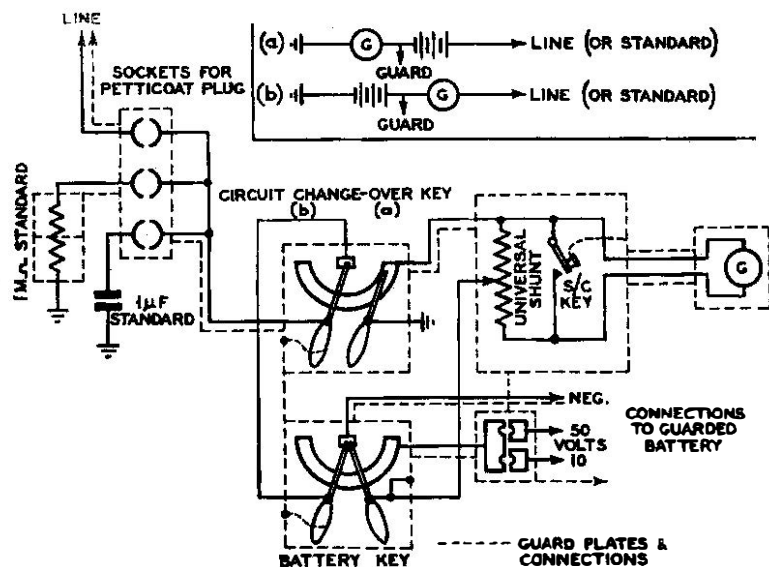

FIG. 4.—CIRCUIT DIAGRAM OF THE INSULATION (DIELECTRIC RESISTANCE) TEST SET.

in Fig. 4, illustrate the principle. In order that apparatus or surface leakages do not affect the reading, it is arranged that all such leakages must take place initially to a conducting guard system, which is connected to the junction of galvanometer and battery. The leakage currents then return to the battery without passing through the galvanometer. Each individual insulating pillar and piece of apparatus is so guarded where necessary.

The screws holding the pillars are tapped where possible through the guard plates, so that the sheet of metal is unbroken, and the metal itself is not lacquered. Surface leakage on the cable end is nullified by a few turns of bare wire (Price's guard ring) round the insulation, the wire being connected to the guard circuit.

A circuit change-over key is provided in order to set up circuit (b), with the galvanometer between battery and line, as this is sometimes requested by representatives of chartering companies. Otherwise, circuit (a) is preferred, because guard plates are of necessity exposed and bare, and any accidental earth on them short-circuits the battery in (b) but merely short circuits the galvanometer in (a). Provided that the battery is a compact unit, circuit (a) is more easily set up in portable equipment for use in situations such as cable huts, because the galvanometer circuit need not be guarded and need have only reasonable insulation.

The dielectric resistance test is made with each direction of current in the line, to allow for the effect of earth P.D.s. The algebraic mean of the deflections is taken when calculating the dielectric resistance, after allowing for the fact that the positive direction of galvanometer deflection reverses with the reversal of current.

It is not correct to calculate the resistances separately and then take the mean. If the two readings be considerably different, the deflection with no battery is taken to check whether the change of reading is due to earth P.D.s.

Much can be learnt from the effect of the line on the D.R. set as to the possible existence of an incipient fault. To allow for the charging of the cable, it is usual to note the deflections at intervals over a period of two to five minutes, and to observe the general behaviour of the light spot over the same period.

On gutta-percha cables two voltages are normally employed, 10 for old and 50 for new. These suffice for obtaining definite insulation values, except on very short lengths. The balanced, reflecting type galvanometer is used with a centre zero scale, and has a sensitivity of 22 mm. per micro amp. Although the galvanometer is not ballistic, it may be used to give reasonable measurement of capacitance by "throws" on lengths up to about 50 nautical miles. The use of the D.R. set for capacitance measurement is particularly useful on very short lengths,

and no throw is obtained from the guarded leads. A standard 1 microfarad capacitor is included for calibrating the galvanometer.

#### D.C. CAPACITANCE TEST SET

The two most generally accepted methods of measuring the D.C. capacitance of long cables are those of Kelvin and Gott. The latter is rather quicker, but has a disadvantage in the way in which the different time-constants of the line and standard capacitor affect the obtaining of a balance. Attempts to make the time-constants more nearly equal may lead to the balance being controlled to a certain extent by the resistances added to the network. It is difficult to see why Kelvin's method of mixtures has tended to be superseded by Gott's method, and the former is the test employed in *Monarch*.

Fig. 5 shows the circuit used. The line is charged

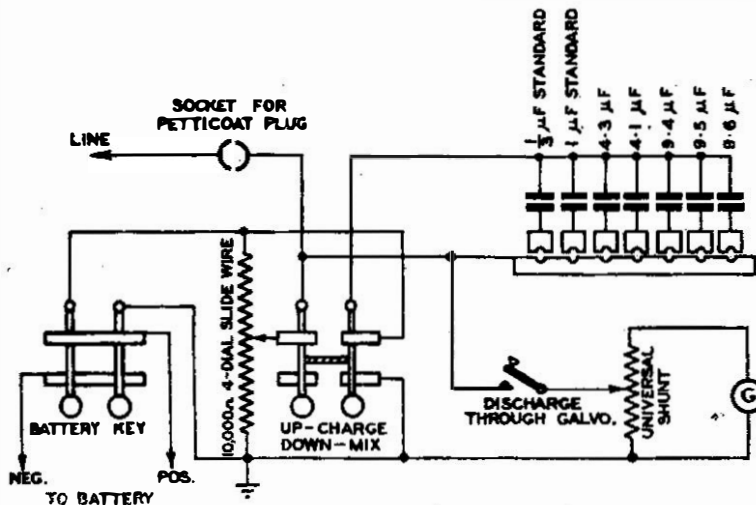

FIG. 5.—CIRCUIT DIAGRAM OF THE D.C. CAPACITANCE (MIXTURE) TEST SET.

from part of the slide wire, and the standard capacitor from the remainder. After 15 to 30 seconds the slide wire is disconnected and the charges allowed to mix for a similar time, the residual charge then being put through a galvanometer. Balance is obtained by varying the slide position until the residual is zero or negligibly small. In practice, the balance point may be accurately estimated once two reasonably close positions have been noted giving residuals of opposite sign and known relative magnitude, as judged by the direction and magnitude of the galvanometer throw. It is usual to make the test with the two polarities of battery (10 V or so) in order to reduce any error due to earth P.D.s.

The reflecting galvanometer employed is more ballistic than those previously referred to, and has a current sensitivity of 380 mm. per micro-amp. It is not balanced, but little difficulty is experienced in observing "kicks" superimposed on slow movements due to the roll and pitch of the ship.

Reference to Fig. 5 will show that the main difference in the circuit compared with the mixtures-test circuit, as usually drawn, is that earth is connected directly to one end of the slide wire (4 dial). The

battery is connected across the slide through the usual type of key, the leads being kept entirely independent of the charge-mix key wiring except at the junctions on the slide terminals. The insulation resistances to earth of the battery and one side of the standard capacitor merely shunt the whole slide wire. The cable insulation shunts the lower end of the slide, and if necessary the value of the standard capacitance may be kept rather low in order that the slide is near the bottom end at balance, thus reducing the shunt error. The insulation to earth of the slider side of the standard capacitor should be good and also, of course, the intrinsic insulation of the capacitor itself. In practice no trouble has been experienced due to low insulation on this part of the circuit. Should this occur, it is possible by the use of a standard, smaller than the capacitance to be measured, to work with the standard right across the slide wire, with only a slight extra complication in the keying arrangements.

Two standard mica capacitors of  $\frac{1}{3}$  microfarad and 1 microfarad respectively are used with the set. Other mica capacitors, which are recalibrated at suitable intervals, enable larger capacitances to be obtained.

#### RECORDER, A.C. BRIDGE AND MISCELLANEOUS APPARATUS

##### Recorder Circuit.

Signalling is carried out by a form of Morse code with "dots" and "dashes" of equal length but opposite polarity, a syphon recorder being used for the reception of signals. This is essentially a moving-coil galvanometer; passage of the signalling current deflects the coil, which in turn causes an ink-carrying glass syphon to mark a trace on a moving slip of paper. The

circuit, shown in Fig. 6, is that of the long-distance recorder. A capacitor may be inserted in series in the receive condition to provide a rough degree of equalisation, to restore signal shape. This is rarely used on the ship, as sensitivity is seriously impaired unless the capacitance is made considerably larger than the 10 microfarads shown. A less sensitive recorder is also available. The circuit is similar to Fig. 6 except that no capacitor is included, and an adjustable resistance is put in series with the line to reduce the current on short cables. Using both recorders is an advantage when testing to stations at both ends before a final splice, as continual adjustment of shunts and battery powers is avoided.

##### A.C. Bridge.

The A.C. bridge is used in the localisation of faults by the impedance/frequency method, and also, when opportunity serves, in determining the constants of various sizes and types of cable.

A schematic diagram of the bridge and associated apparatus is given in Fig. 7, and indicates the facilities available for connecting up the oscillator and detector units to the bridge by plug-ended cords.

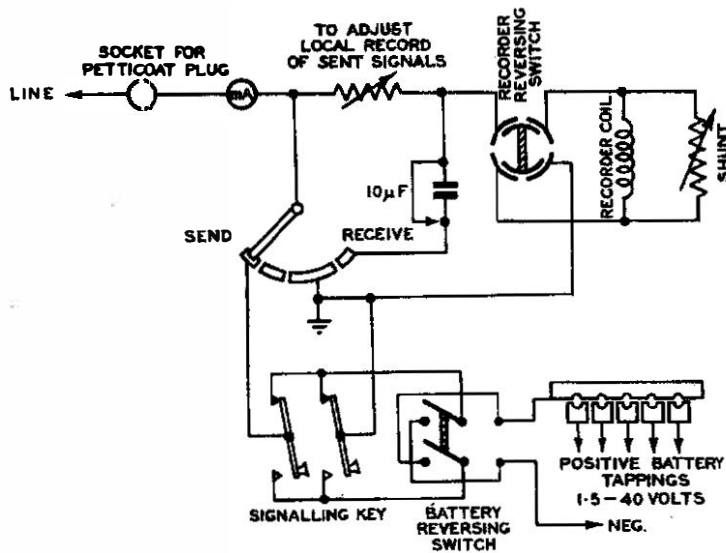

FIG. 6.—CIRCUIT DIAGRAM OF THE LONG-DISTANCE RECORDER.

With the exception of the heterodyne detector all the units are mains driven, the power packs for the sub-audio oscillator and amplifier being of particularly low impedance.

As far as can be foreseen, *Monarch* is likely to have to deal with unbalanced cable only, and the bridge is, therefore, wired with one point earthed. The impedances to be dealt with vary over a wide range of modulus and angle, and a large degree of flexibility of interconnecting components is required. Furthermore, the range of frequency required is also very wide, so that a ratio-arm bridge is preferred. This has the advantage of being satisfactory up to the highest frequency employed (111 kc/s), which has been found

to be adequate, while enabling very low frequencies (down to 1 c/s) to be used if required.

Normally the ratio arms are each of 1,000 ohms, but it is possible to change over to 100 ohms should these give an advantage, such as when making tests at carrier and high audio frequencies where the characteristic impedances of the cables are of the order of 40-60 ohms.

To obtain the flexibility of interconnection already referred to, a system of jacks and low-capacitance keys is used, although this is an expedient that is normally best avoided in precision A.C. bridge work. However, attention has been paid in the wiring layout to reduce to a minimum inductance and capacitance errors. Where accuracy in absolute measurements is required, substitution methods are employed. This is particularly necessary at sub-audio frequencies, where in any case a series-artifice bridge (added capacitance

in series with the line) has to be resorted to in order to measure the large capacitance component of the cable impedance.

In the impedance/frequency method of fault localisation the impedance measured by the bridge will differ from the characteristic impedance, provided that the wave reflected from the fault is not unduly attenuated during its passage back to the sending end. If the received reflected voltage is in phase with the sent voltage, the impedance will be a maximum, and the respective currents are out of phase. When the converse applies, the impedance will be a minimum. The phase is dependent on the total phase-change along the cable to the fault and back, and provided

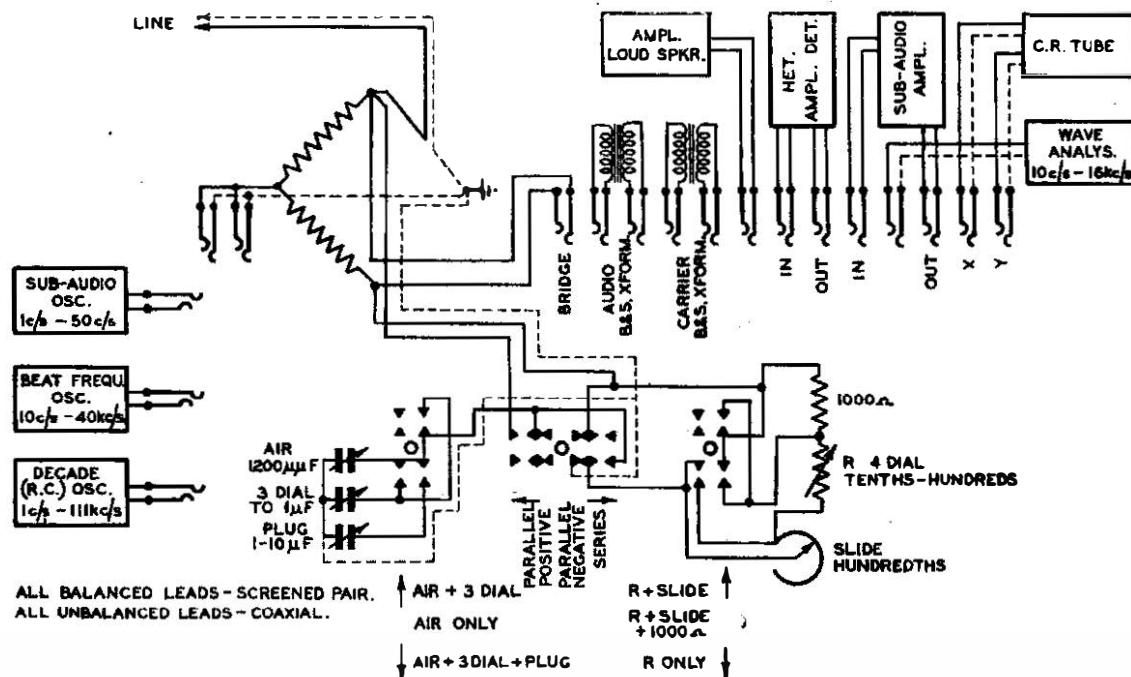

FIG. 7.—SCHEMATIC DIAGRAM OF THE IMPEDANCE BRIDGE.

that the phase constant per unit length of the cable is known, the distance to the fault may be determined once the total phase change has been found. In practice, it is best to observe the alteration in total phase change with frequency by measuring the sending-end impedance over a suitable frequency range, the modulus of this impedance passing alternately through maximum and minimum values. Since the difference in total phase change between successive maxima (or minima) is  $2\pi$  radians, and the corresponding frequencies  $f_1, f_2$  are known, then

$$\beta_2 2x - \beta_1 2x = 2\pi$$

where  $\beta_1, \beta_2$  are the phase constants of the cable in radians per nautical mile at  $f_1$  and  $f_2$  respectively, and  $x$  is the distance to the fault in nautical miles. (It is assumed that the phase change at the fault does not vary significantly with frequency.)

A typical value for the velocity of propagation at carrier frequencies of a gutta-percha submarine cable is 70,000 n.m. per second, and the wavelength in n.m. at 110 kc/s is then about 0.64 n.m. This means that the frequency is adequate to enable a difference of  $2\pi$  radians in phase-change to be measured on 0.32 n.m. of cable, or  $\pi$  radians (working between a successive maximum and minimum, or vice versa, on the sending-end impedance frequency characteristic) on 0.16 n.m. of cable. As the ship would invariably pick up to any fault within this distance, the limiting condition is satisfactory.

It can be shown that, for a fault giving practically a full reflection, the phase-change to the fault and back will always be at least  $2\pi$  radians when the cable attenuation to the fault is 27.3 db. If the bridge and associated apparatus is sufficiently sensitive to detect changes in impedance at this attenuation distance, the corresponding limit of physical distance is governed by the capability of measuring at sufficiently low frequencies.

It is for the purpose of investigating the possibility of localising faults up to 1,000 nautical miles from the ship that the sub-audio apparatus has been installed. The output of the tuned amplifier connected to the bridge is fed to the Y-plate amplifier of the cathode-ray tube, with the oscillator giving a horizontal sweep on the X-plates. At balance there is no vertical movement of the trace, except that due to harmonics (when present) and these are clearly distinguished from the fundamental by the distinctive pattern.

The wave-analyser is used as an amplifier-detector on the bridge for low frequencies above the range of the sub-audio apparatus, and is a useful alternative to the other detecting equipment up to 16 kc/s.

The interpretation of results obtained at very low frequencies, compared with that at higher frequencies, is made more difficult by the rapid change of characteristic impedance with frequency, and by the fact that the velocity of transmission is itself frequency-dependent. Whatever frequency range is involved, however, it is almost always useful to recognise the fact that the phase constant,  $\beta$ , becomes indefinitely small as frequency decreases towards zero, thus giving one known point on all phase-constant/frequency cable characteristics.

#### *Miscellaneous Apparatus.*

Two portable self-contained D.C. testing sets are carried for boat or beach work, in addition to spares for the main components of the D.C. sets in the testing room. These latter components are useful in connecting up for such tests as the Murray, which are required only infrequently.

For the location of the line of a cable, a search coil is available for beach work, and a 17 c/s amplifier-detector for use in the ship when towing electrodes. Satisfactory results have been obtained using standard paragutta 508/690 core with bared ends as electrodes.

Should the ship be required to work on multicore cables, the usual quad-switching and terminating devices are available, and attenuation and crosstalk sets may be built up.

#### *Future Developments.*

One troublesome factor in the measurement of conductor resistance on cable coiled in the tanks is the variable E.M.F. caused by the turns moving relative to the earth's magnetic field, when the ship rolls or pitches. Where possible, separate lengths of cable are joined up so that their induced E.M.F.s are opposing. In order to have a counter E.M.F. available at all times, it is proposed that a single turn of multi-core cable be laid round each tank. The conductors will be joined in series to give an effect similar to many turns of cable. It is not certain how serious residual phase difference will be, but it can possibly be overcome by using both the number of turns of the "ballast" coil and a potentiometer to get the right magnitude of counter E.M.F. The induced E.M.F. in tank cable also makes it more difficult to observe the dielectric resistance in the earlier stages of a long laying operation.

Another improvement, especially when laying a long cable, will be to have the cable engine revolutions repeated to the testing room. With a suitable make and break device, it has been found possible to operate meters of the subscriber's type. It is hoped also to arrange for the temperatures of the tanks to be read at any time on a meter in the testing room.

It is intended that pulse apparatus shall be tried for the quick localisation of faults near the ship. The utility of this type of apparatus will be restricted by the high attenuation of normal sizes of telegraph cable. If, in order to increase the range, lower frequencies than those employed in pulse apparatus designed for land coaxial cables are used, then considerable distortion of the received pulse must be expected, both on account of the attenuation/frequency and the velocity/frequency relationships.

#### *Acknowledgments.*

It is desired to thank the Commander and the Submarine Superintendent for permission to publish this article. Thanks are also due to Mr. W. H. Reynolds, Mr. R. Pharo and other colleagues for assistance at different times, and to the Chief Electricians of Cable and Wireless, Ltd., who have served in the ship from time to time as representatives.

# A Method of Reducing the Vibration from Diesel Engine Generating Sets

J. H. ALDERSON, M.A., A.M.I.E.E.

U.D.C. 621.313.322-84 : 621-752.2

This article describes the various types of objectionable vibrations likely to be set up by a diesel engine driving an electric generator. The problem is considered theoretically and a method of mounting the bedplate on springs or other resilient material in order to reduce the amplitude of the vibrations is described. The article is illustrated by photographs of some recent Post Office standby diesel engine generating sets mounted in this manner.

## Introduction.

THE widespread and increasing use by the Post Office of stationary diesel engine generating sets to provide standby electricity supplies to important buildings has drawn attention to the noise and vibration which such machines cause. This problem has been accentuated by the introduction of engines running at higher and higher speeds, viz. 1,000 r.p.m. and even 1,500 r.p.m. Speeds of this order present very different problems from the 200-300 r.p.m. of the earlier single- and twin-cylinder horizontal diesel engines, which were such a familiar sight in the early repeater stations, where they were frequently the only source of electricity supply. A standby engine can with advantage be designed to run at a higher speed than an engine which is the sole source of power to a building and must be run continuously for long periods. The higher speed enables a more compact engine requiring less accommodation to be installed, but more elaborate measures may be required to deal effectively with the vibration caused by the engine.

This article deals mainly with the case of diesel engine generating sets installed in Post Office buildings, but the methods described below may be extended to apply to all types of rotating and reciprocating machinery and impact machines such as power hammers and drop stamps.

## Vibration.

Vibration is inherent in the design of reciprocating machinery, and is due to the horizontal and vertical forces caused by the unbalanced reciprocating and rotating masses and, in the case of internal combustion engines, to the explosive effects as the fuel is ignited and burnt. Improvement to an extent depending on the number of cylinders in the engine can be effected by means of balancing and this is done as a normal part of engine design. The first harmonic can be eliminated by balancing the rotating masses of the cranks, but the higher harmonics are not normally dealt with as the problem is too involved and costly. The higher harmonics can, however, be avoided, in some cases entirely, by selecting the number of cylinders, e.g. dynamic balance can be obtained with a 6-cylinder engine. In the case of the 4-cylinder engine, there is an appreciable second harmonic, which is not normally balanced, although in very exceptional cases where perfect balance is essential it can be eliminated by incorporating twin rotating masses rotating in opposite directions and driven at twice the speed of the engine through crank shaft gearing.

The problem is accordingly to reduce the inherent

undesirable vibration to an amount that can be tolerated without inconvenience. In extreme cases it will be necessary to reduce the vibration to prevent damage to the surrounding building and the machine itself.

The vibration will be perceptible partly as noise and partly as movement, and may be analysed as follows:—

- (i) Air vibrations are heard as noise and consist of primary and secondary air vibrations. Primary air vibrations are transmitted directly by the machine to the surrounding air and are heard only in the machine room and the immediate vicinity. Secondary air vibrations are caused at any point by the transmitted foundation vibrations.
- (ii) Foundation vibrations are produced in the foundations and transmitted with high efficiency throughout the building, to adjacent buildings and the ground itself, where they may be detected as movement or secondary air vibrations.

## Foundation Vibrations.

The various types of vibration transmitted by a machine not isolated from its foundations are shown in diagrammatical form in Fig. 1. Care must be

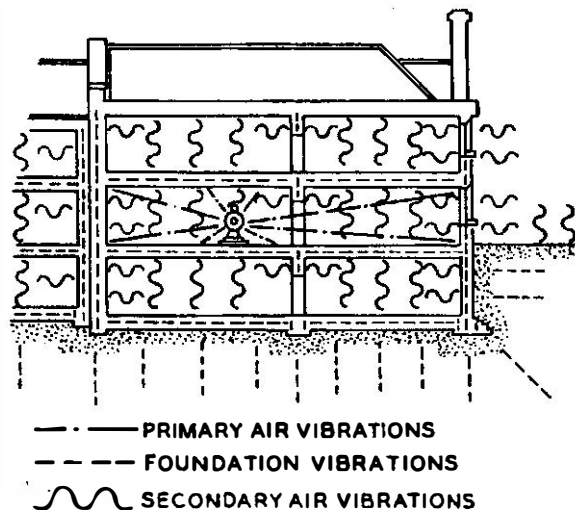

FIG. 1.—VIBRATIONS TRANSMITTED BY A MACHINE NOT ISOLATED FROM ITS BED.

taken not to confuse secondary air vibrations with primary air vibrations when the former happen to be of the same frequency as the latter. Consideration of the layout of the building should enable the two types of air vibration to be distinguished in such

cases. Foundation vibrations may be transmitted long distances and reappear as noise or hum. Measurement of the fundamental frequency will, in most cases, enable it to be traced to its source.

The effect of isolating a machine from its foundations is shown in diagrammatical form in Fig. 2. The

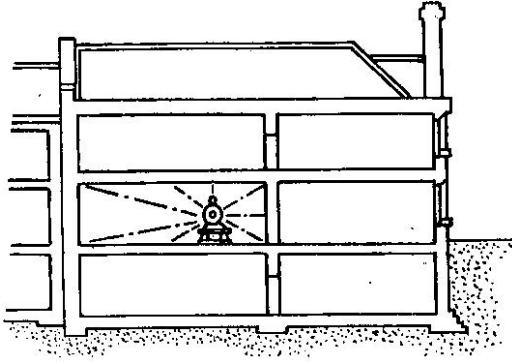

FIG. 2.—EFFECT OF ISOLATING MACHINE FROM ITS BED.

transmission of the foundation vibrations from the machine to its foundations has been stopped and consequently the secondary air vibrations have been eliminated. Further, the intensity of noise in the machine room will have been reduced, and this can be prevented from spreading by suitable sound-proofing of the room if required.

From the foregoing it will be seen that the problem resolves itself into the prevention of the transmission of the foundation vibrations. This can be done to a greater or lesser degree by interposing some form of elastic material between the machine and its foundations. It will be helpful at this point to consider the problem dynamically and determine the equation of motion of a mass supported on a spring subject to a forced vibration.

#### Theoretical Treatment.

Fig. 3 shows a mass  $M$  supported on an elastic

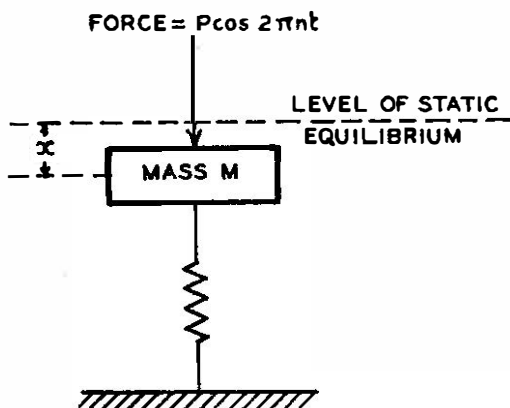

FIG. 3.—FORCED VIBRATION OF A MASS SUPPORTED ON A SPRING.

spring and acted upon by a force  $P$  varying harmonically with a frequency  $n$ .

Suppose that the strength of the spring is such that when the compression is  $x$ , the force in the spring is  $\mu x$ .

Then the equation of motion is:—

$$M \frac{d^2x}{dt^2} = -\mu x + P \cos 2\pi nt$$

$$\text{or } M \frac{d^2x}{dt^2} + \mu x = P \cos 2\pi nt$$

The complete solution of this differential equation is:—

$$x = A \cos \sqrt{\frac{\mu}{M}} t + B \sin \sqrt{\frac{\mu}{M}} t + \frac{P \cos 2\pi nt}{\mu - 4\pi^2 n^2 M}$$

Let  $\sqrt{(\mu/M)} = 2\pi n_0$ , where  $n_0$  is the natural frequency of vibration of the spring and mass  $M$ . This gives

$$x = A \cos 2\pi n_0 t + B \sin 2\pi n_0 t + \frac{P \cos 2\pi nt}{\mu(1 - n^2/n_0^2)}$$

Consider the motion where  $M$  starts from rest from the position of static equilibrium:—

$$(i) \text{ When } t = 0, x = 0 \therefore A = -\frac{P}{\mu} \cdot \frac{1}{1 - n^2/n_0^2}$$

$$(ii) \text{ When } t = 0, \frac{dx}{dt} = 0 \therefore B = 0$$

Now let  $P/\mu = e$ , where  $e$  is the compression of the spring produced by a steady force  $P$ .

Equation of motion now becomes

$$x = \frac{e}{1 - n^2/n_0^2} (\cos 2\pi nt - \cos 2\pi n_0 t)$$

In actual practice the second term, representing the natural frequency of the system, will be associated with a damping factor and will be eliminated after an interval of time. The state of steady motion will, therefore, be represented by

$$x = \frac{e}{1 - n^2/n_0^2} \cos 2\pi nt$$

From this it will be seen that the effect of the spring in reducing the amplitude of vibration of the mass  $M$ , and thus the force tending to cause foundation vibration, will be considerable where  $n/n_0$  is large, i.e. where the natural frequency of the spring and mass is small compared with the frequency of the disturbing force. If  $n$  is less than  $n_0$  the vibrations will be magnified, while if  $n = n_0$  a dangerous condition of resonance will be set up.

#### Reduction of Vibration.

To be of any practical value in reducing the amount of the vibration caused by a machine, therefore, the characteristics of the elastic foundation material must be such that the natural frequency of vibration of the machine on the elastic material is well below the frequency of the forced vibrations. From this it follows that a method of preventing the transmission of the higher frequencies will not necessarily prevent the transmission of the lower frequencies, although a method of preventing the transmission of the lower frequencies will also prevent the transmission of the higher frequencies.

#### Elastic Foundation Material.

Two types of elastic material can be used to isolate a machine from its foundations:—

- (i) A layer of cork, felt or rubber may be placed under the concrete foundation block forming the bed of the machine, or directly under the machine bedplate if this is suitable and stiff enough to withstand any torsional stresses imposed upon it by the machine.
- (ii) Specially designed springs with a low natural frequency of vibration may be used in place of the layer of elastic material to support the machine.

In order to give some idea of the amount by which the transmission of vibration may be reduced by these methods, the two following examples will serve as illustrations.

First, consider a four-cylinder engine running at

large mass, the energy of the unbalanced forces is partially absorbed in moving the mass, thus reducing the amplitude of the transmitted vibrations. The improvement to be gained in this direction, however, is strictly limited by the cost and physical dimensions of the concrete block.

**Anti-vibrators.**

A patented type of spring mounting, designed by the firm of Messrs. W. Christie & Grey, Ltd., has been on the market for a number of years, and is very effective in reducing foundation vibrations produced by all types of machine. This is known as the "Anti-vibrator" and the pedestal type is shown in detail in Figs. 4 and 5.

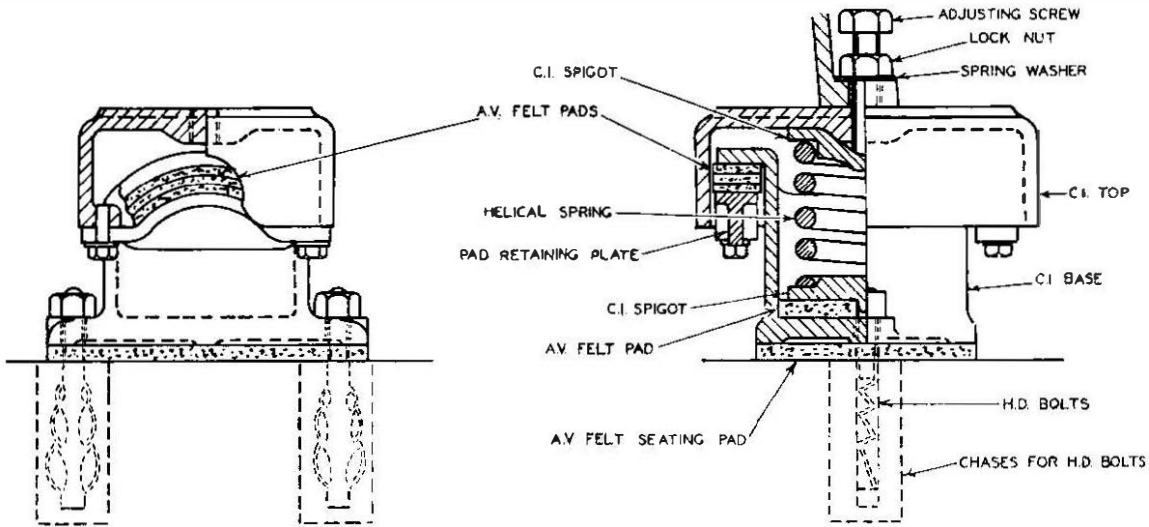

FIG. 4.—CONSTRUCTION OF A TYPICAL PEDESTAL-TYPE ANTI-VIBRATOR.

800 r.p.m. mounted on a layer of cork subjected to a loading of 1 ton per sq. ft. The natural frequency of the cork will be about 1,000 per minute, and the principal frequency to be suppressed will be the second harmonic of 1,600 per minute. The ratio of reduction is

$$\frac{1}{1 - (1,600/1,000)^2} = \frac{1}{1.56}$$

or approximately 35 per cent.

Second, consider a machine with an out-of-balance frequency of 750 per minute mounted on springs having a natural frequency of 150 per minute under a loading of 10 cwt. The ratio of reduction is

$$\frac{1}{1 - (750/150)^2} = \frac{1}{24}$$

or approximately 95 per cent.

In practice the reduction will be less than the calculated value. With the maximum practicable difference between natural frequency and that to be suppressed, reductions of 65 per cent. for cork and 90-95 per cent. for springs may be expected. By mounting the machine on a concrete bed of

The top portion of the anti-vibrator is bolted to the base of the machine and the bottom portion to the floor. The main isolating medium between the two halves consists of a helical spring designed to have a natural frequency under load well below the out-of-

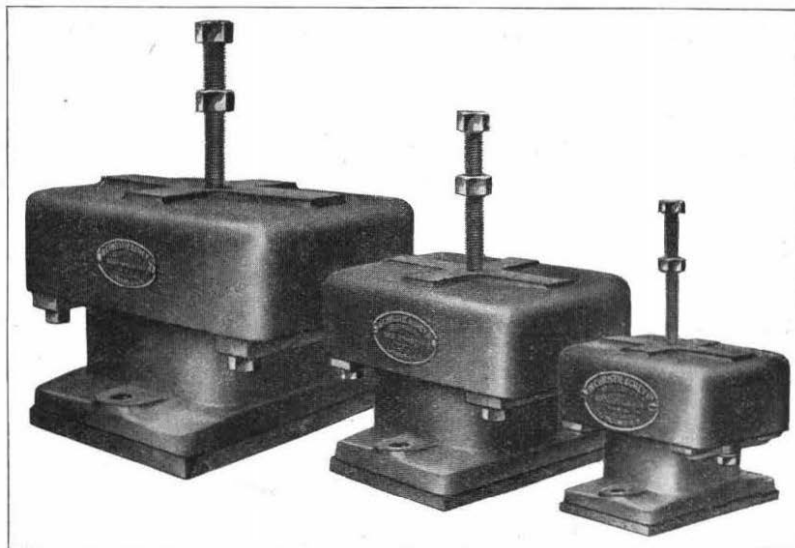

FIG. 5.—PEDESTAL-TYPE ANTI-VIBRATORS.

balance frequencies of the machine. In addition, anti-vibration felt pads are placed beneath the spring and the base of the unit to attenuate any high or audible frequencies which may pass through the spring steel. The two felt pads in the form of an arch at the sides of the unit will look after any horizontal out-of-balance forces. The most efficient adjustment of the anti-vibrator is when the side felt pads are just in contact with the base of the unit.

The bridge-type anti-vibrator, shown in Fig. 6, is

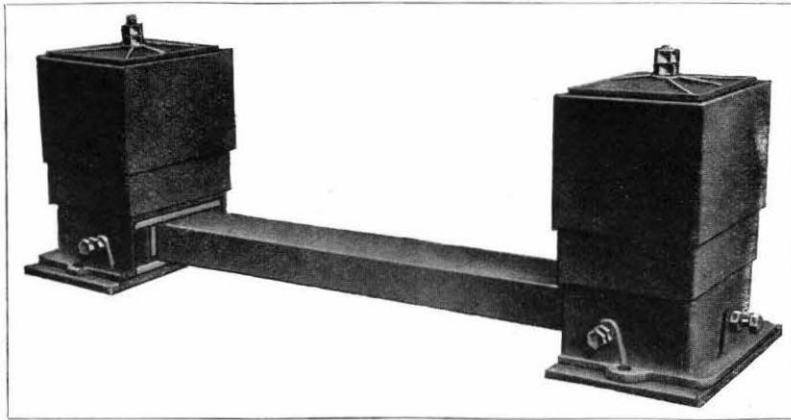

FIG. 6.—BRIDGE-TYPE ANTI-VIBRATOR.

an alternative arrangement which can be used with advantage when headroom is restricted. The machine is bolted to the steel channel section forming the bridge, the ends of which are supported on springs and felt pads operating on the same principle as the pedestal type.

#### *Resonance.*

It will be noted that the machine will pass through the resonant frequency of the springs whenever it is started up and shut down, but provided these operations are performed as quickly as possible no damage will occur. Vibrations of appreciable amplitude will be set up, but these will die away very rapidly as soon as the resonant frequency is passed. Care must be exercised to ensure that the resonant speed is passed through quickly, as vibrations of a dangerous amplitude will be rapidly built up if there is any hesitation near the resonant speed. This should be a most unlikely occurrence, however, as springs should never be used for low-speed machines, and the resonant speed will be only a small fraction of the normal running speed of the machine.

#### *Some Post Office Installations.*

In 1947, it was decided to purchase a number of diesel engine generating sets to serve as standby sources of power to safeguard the services in important buildings in case of power failure or load shedding. Several firms received bulk allocations of steel and

other materials to enable them to make large numbers of standard sets and delivery was obtained more quickly than would have been the case had sets been ordered specially for each requirement. The sets were self-contained, being mounted on a heavy fabricated steel bedplate on which was included a simple switch-board to control the output of the generator.

The Post Office bought forty sets from Messrs. Davey Paxman, Ltd., each consisting of an 80-h.p. 4-cylinder diesel engine running at 1,000 r.p.m. direct-coupled to a 65-kVA, 400-V, 3-phase, 50-c/s, 0.8 power factor alternator with belt-driven exciter mounted upon it.

The sets are transportable as units and do not require specially prepared foundations. This was of considerable advantage as it was desired to have the sets in service as quickly as possible without having to wait for elaborate foundations to be prepared. Another consideration was that a number of the sets would probably be required in the buildings to which they were first allocated for a limited period of time, after which they could be transferred elsewhere.

It was therefore desirable to keep the cost of the foundations to a minimum and their design as simple as possible to facilitate later removal.

Under these circumstances, the use of anti-vibrators had everything in its favour and it was decided to install the whole of the 40 sets on anti-vibrators. The sets weigh approximately 4½ tons and are mounted on 10 anti-vibrators, each capable of carrying a load of 10 cwt. Fig. 7 shows the anti-vibrators installed on the existing basement floor ready to receive the 65-kVA set at Clerkenwell exchange.

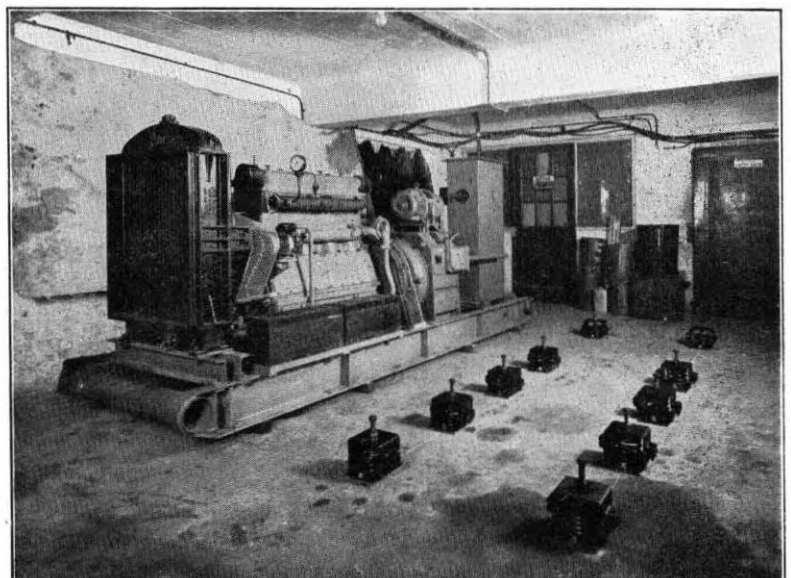

FIG. 7.—DAVEY PAXMAN 65-kVA SET WITH ANTI-VIBRATORS AT CLERKENWELL EXCHANGE.



These anti-vibrators differ from those illustrated in Figs. 4 and 5, being of a simpler prefabricated type, due to the difficulty in obtaining the necessary cast iron castings at that time. The essential components are the same, however, and they are equally effective in reducing vibration from the sets.

A completed installation at Museum exchange is shown in Fig. 8. In addition to the anti-vibrator

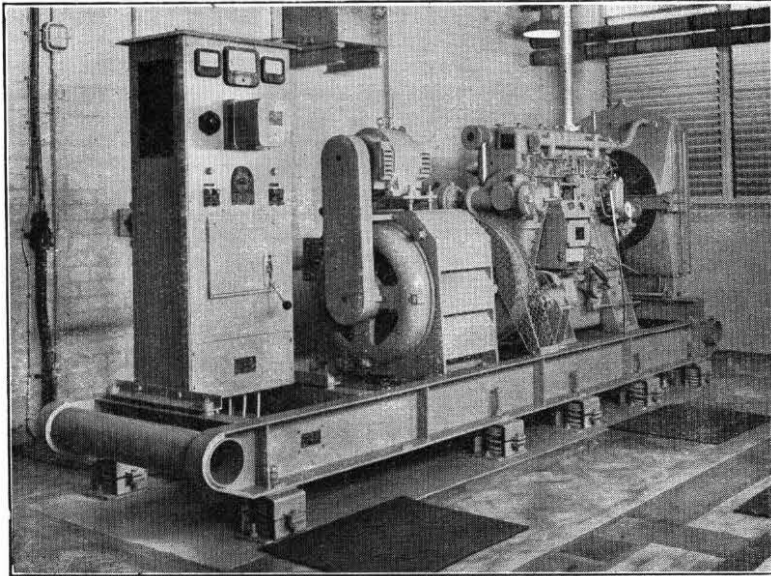

FIG. 8.—DAVEY PAXMAN 65-KVA SET MOUNTED ON ANTI-VIBRATORS AT MUSEUM EXCHANGE.

spring mountings, all connections to the set, i.e., cable in conduit, exhaust, fuel oil and cooling air, are flexible connections to prevent any transmission of vibration. The set runs very smoothly, and the amount of vibration transmitted to the building is negligible. As mentioned earlier, the set does rock noticeably when it passes through the resonant frequency of the springs on being run up to speed or shut down, but the springs are able to look after this transient condition.

For mainly similar reasons the standby sets in the four intermediate relay stations on the London-Birmingham Television Radio-Relay Link have also been mounted on anti-vibrators. Each of these sets consists of a Ruston and Hornsby 30-h.p., 3-cylinder diesel engine, running at 1,000 r.p.m. direct-coupled to a 20-kVA, 0.8 power factor alternator with mains voltage characteristics. Each set is mounted on ten 5-cwt capacity anti-vibrators, and the

complete installation at the Dunstable relay station is shown in Fig. 9.

#### *Early Application of Anti-vibrators.*

When the writer was preparing the material for this article the following very interesting early application of the use of anti-vibrators in the Post Office was brought to light. It appears that in the old Portsmouth T.E. the motor-generator sets for battery charging were installed upon an upper floor of the building and caused a considerable amount of vibration. So many complaints were made locally that in the end the machines were mounted on anti-vibrators. This occurred in 1915 and was apparently completely successful. The reason for the excessive vibration was probably that the speed of the motor generator sets was the same or very close to the natural frequency of vibration of the floor on which they were installed. Isolation of the sets would prevent the floor from vibrating, and in an extreme case would prevent damage being caused to the fabric of the building.

#### *Conclusion.*

In conclusion, the author would like to thank Mr. W. B. Grey of Messrs. W. Christie & Grey, Ltd., for his kindness in providing information and the drawings and photographs for Figs. 1, 2, 4, 5 and 6.

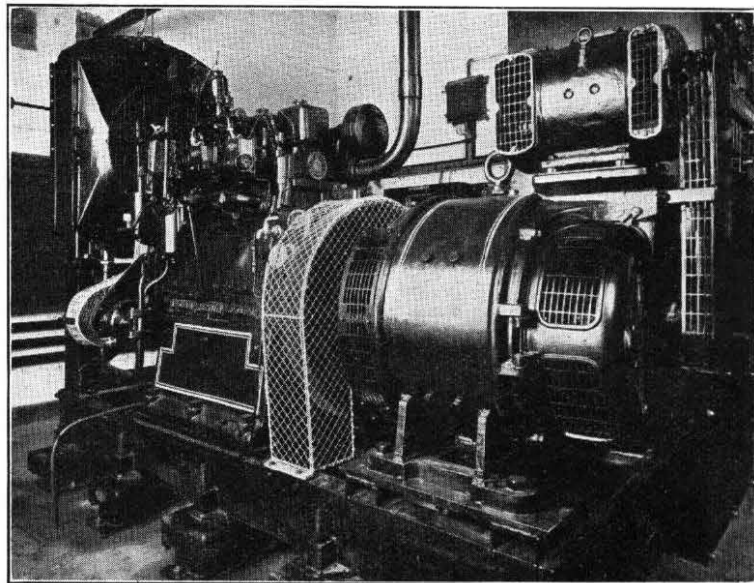

FIG. 9.—RUSTON & HORNSBY 20-KVA SET MOUNTED ON ANTI-VIBRATORS AT DUNSTABLE TELEVISION RELAY STATION.

## Book Reviews

"Aerials for Metre and Decimetre Wavelengths." R. A. Smith, M.A., Ph.D., A.M.I.E.E. Cambridge University Press (Modern Radio Technique Series). 218 pp. 126 ill. 18s.

This book is mainly about aerials for the "metric" (1 m to 10 m) range of wavelengths, but a short chapter on aerials for the range 0.1m to 1.0m is included. Aerials for the "centimetric" range are to be dealt with in a companion volume.\*

Aerials used for the metric range comprise dipoles, used singly and in arrays, Yagis, slots and long-wire aerials such as rhombics and Vees.

Aerials for the metric range of wavelengths are of considerable interest to Post Office radio engineers since many of the Department's single and multi-channel radio telephony links between the mainland and islands, e.g. Chaldon-Guernsey and Holyhead-Douglas, operate in this range.

The present book contains not only the basic theory of metric aerials but also much information of an essentially practical kind derived from the author's wide experience with radar aerials at the Telecommunications Research Establishment, Ministry of Supply. It is perhaps a minor criticism of the book that most of the examples of aerial design selected to illustrate the theory are drawn from radar practice; the book would have been more generally useful had aerials for sound and television broadcasting and for mobile and point-to-point communications systems also been described.

However, the book is thoroughly recommended not only for the clarity of the theoretical treatment, but also for the considerable amount of practical information, much of it hitherto unpublished, which is presented.

W. J. B.

\* "Aerials for Centimetric Wavelengths," by D. W. Fry and F. K. Goward, Modern Technique Series, Cambridge University Press.

"Pulses and Transients in Communication Circuits." Colin Cherry, M.Sc.(Eng.), A.M.I.E.E. Chapman & Hall, Ltd. 317 pp. 129 ill. 30s.

Anyone familiar with Mr. Cherry's works will expect this book to be refreshing and instructive, and they will not be disappointed. The last ten or fifteen years have seen very big changes in telecommunications engineering, due largely to the introduction of television, radar and time-division systems. Where formerly very few of us needed to consider the transient behaviour of networks, nowadays it is often a vital and sometimes a troublesome part of our work—troublesome because, as Mr. Cherry says in his preface, much that has been written on the subject "is in the form and style of professional mathematicians."

Strangely enough, the first chapter, which is devoted to introducing and solving the differential equations that form the basis of network theory, is a little disappointing and the discussions and explanations, so obviously intended to make the treatment simple, are so long that one is liable to lose the thread of the argument.

After considering the frequency spectra of recurrent and non-recurrent waveforms a general study is made of the steady-state properties of two- and four-terminal networks. Having thoroughly prepared the way, the author goes on to discuss the time responses of passive networks to pulses of different shapes and to suddenly applied sinewaves. Although the treatment is generally very good there is one part that is misleading. It is implied on pages 168 and 170 that, in practice, low-pass filters cannot be made to have the same skew-symmetrical

response to a Heaviside Unit Function as an idealised filter that cuts off sharply and has no delay. But low-pass filters are not infrequently designed to have a fairly sharp cut-off with a substantially constant phase delay up to and beyond the cut-off point, and the response of such a filter approaches that of the ideal network very closely. The point that the author and others seem to have overlooked is that if the phase delay of a network is substantial, the main part of the response can be preceded by ripples without requiring the ripples to appear at the output before the stepwave is applied to the input! The whole subject of low-pass networks with linear phase characteristics, i.e. constant phase delay, through the cut-off is of great importance in television.

The treatment of the steady-state and transient behaviour of asymmetric sideband systems is clearer and more comprehensive than in any other book that has come to hand, which is fortunate as the subject is difficult and asymmetric sideband operation is used in this country for relaying television over cables and for television broadcasting itself. Further subjects discussed include the time responses of amplifiers, the effects of echoes, and the estimation of time-response distortion in terms of amplitude and phase distortion using the method of paired echoes, another subject on which most text books are silent. The value of the present publication is increased by the extensive bibliographies, containing 20 to 30 references, that appear at the end of each chapter. The author has carefully avoided making the subject more mathematical than is absolutely necessary; his object was to write a book for television and radar engineers, not for mathematicians, and as an engineer the reviewer congratulates him on his success.

I.P.O.E.E. Library No. 1891.

H. S.

"Principles of Microwave Circuits." Vol. 8 in the Radiation Laboratory Series (Massachusetts Institute of Technology). Edited by C. G. Montgomery, R. H. Dicke and E. M. Purcell. 486 pp., 293 ill., McGraw-Hill Publishing Co., Ltd., 36s.

This book deals with the application of Maxwell's electromagnetic field equations to the analysis of microwave circuit elements such as waveguides with inductive slit and capacitive diaphragms, resonant irises, tuning devices, resonant cavities, waveguide junctions with multiple arms including the "magic" or hybrid T, directional couplers and similar devices. Where possible use is made of the normalised impedance concept and the equivalent circuit representation of microwave circuit elements.

The engineer looking for a ready-made solution to a specific microwave circuit problem will probably not find it in this book; what he will find is a statement of the general theoretical principles from which solutions to specific problems may be derived. Practical solutions of the latter kind are given for example in the "Waveguide Handbook" (Vol. 10 of the Radiation Laboratory Series). It is because of the fundamental nature of the treatment of the subject that the present volume is likely to be of considerable and permanent value to those concerned with the design of microwave equipment; in other words, it provides a basis for tackling new problems not dealt with in text-books of less fundamental scope.

This work has all the clarity of exposition, thoroughness and accuracy that one has come to expect of the Radiation Laboratory Series and is confidently recommended to physicists, engineers and mathematicians interested in electromagnetic field problems at microwave frequencies.

W. J. B.

"Receivers." Stanley K. Lewer, B.Sc. The Radio Society of Great Britain, London, 1949. 96 pp. 98 ill. 3s. 6d.

This small publication, together with a similar volume dealing with transmitting equipment (see below) have both been prepared and published under the general editorship of John Clarricoats, the General Secretary of the R.S.G.B., and are companion volumes to others already produced. The aim of this booklet dealing with receivers is to explain to the novice the general fundamental principles, and to a large extent it succeeds. There are a few criticisms. For instance, on page 14, the term "cross modulation" is suddenly introduced with no explanation as to what it is and reference to the index shows no reference to the term. On page 20, Figures 24 and 25 have been interchanged with unfortunate results. The illustrations are profuse and clear, the inclusion of an occasional photograph being most helpful. An extensive bibliography is provided, but the method of arrangement in chronological order, in which the original articles appear, rather detracts from its utility.

R. J. H.

"Simple Transmitting Equipment." W. H. Allen, M.B.E., and J. W. Matthews. The Radio Society of Great Britain, London, 1949. 44 pp. 20 ill. 2s.

The make-up of this book is similar to that of "Receivers," and again the general editor is John Clarricoats. The aim is to present simple transmitting equipment and associated apparatus in a readable, non-mathematical manner, the method of treatment being to devote the first chapter to fundamentals, the second to aeriels and the remaining chapters to constructional details of specific pieces of apparatus. This method of presentation apparently absolved the authors from the necessity of providing an index. Diagrams and photographs are plentiful and layout drawings are given which enable the would-be constructor to reproduce accurately the various transmitters, etc., described. It is pleasing to see such points as the importance of good earthing arrangements for components stressed and the chapter devoted to aeriels gives the reader a general outline of the subject. Altogether it may be said that this little volume provides much useful information at an extremely reasonable cost.

R. J. H.

"The Mathematics of Circuit Analysis." E. A. Guillemin. John Wiley & Sons, Inc., New York (Chapman & Hall, Ltd., London). 590 pp. 120 ill. \$7.50.

Many branches of communication engineering cannot be adequately studied without the use of mathematical techniques which are outside the scope of most engineering and many mathematical curricula. This book, the fourth in the "Principles of Electrical Engineering" series, by members of the staff of the Massachusetts Institute of Technology, is intended to supplement the normal training of electrical engineers, and the authoritative standing of Professor Guillemin, both as a teacher and as a worker, is sufficient guarantee of a high standard.

The book begins with a study of various advanced algebraic topics associated with linear systems, in four chapters on Determinants, Matrices, Linear Transformations, and Quadratic Forms. A chapter on Vector Analysis follows. The last two chapters, which occupy respectively about a third and a quarter of the book, are on Functions of a Complex Variable and on Fourier Series and Integrals. Each chapter is accompanied by a large number of problems (some 300 altogether), often designed to bring out further theorems not explicitly mentioned in the text.

It will be seen that the subjects treated are comparatively few and can thus be dealt with in fair detail, in as much detail, in fact, as in many of the smaller treatises. The last two chapters, in addition to dealing with general foundations, select various advanced topics which have particular applications to circuit analysis.

Since the book is intended for engineers, mathematical rigour is not insisted upon, but heuristic arguments and appeals to geometric intuition, backed up by the illustrations, are constantly used to make the argument easier to follow; this does not mean, of course, that the various mathematical subtleties associated with limits, convergence, and the like are ignored. Although frequent references are made to practical applications, especially to network synthesis, transients, and potential fields, no attempt is made, either in the text or in the problems, to give a full analysis of any particular practical question.

The various subjects dealt with can, in general, be found in an appropriate mathematical text-book, but the selection of those branches applicable to circuit analysis, and the manner of presentation, will make this book very acceptable to communication engineers.

W. E. T.

"Permanent Magnets." F. G. Spreadbury, A.M.Inst.B.E. Sir Isaac Pitman & Sons, Ltd., London. 280 pp. 173 ill. 35s.

This contains more detail than would be needed in a student's text-book; it may fairly claim to be a work of reference, the first in English on the technical aspects of modern magnetic materials. For this role it is well qualified by excellent contents pages and clear cross-headings throughout the book; on the other hand the index is incomplete, and there is a shortage of references to other books or original papers (there are only 25 such references in the whole book, of which 11 are to the works of one author, Mr. F. G. Spreadbury).

Chapters on the properties and applications of the various alloys, both old and new, are practical in outlook; the alloys are clearly listed and classified, and the scope is broad enough to include oxide magnets and other pressed materials. These chapters would, by themselves, justify the book's existence.

The elementary theory of magnetism is given in the conventional form, with no solution to the usual difficulties—H is "of the same nature as B" so why measure one in oersteds and the other in gauss? The chapter on magnetic measurements makes a rather sudden transition from our old school-friends, the A and B positions of Gauss and the plotting of a B-H loop, to the design of search-coils for testing loudspeaker magnets. On this subject the "Dictionary of Applied Physics," though old, is still excellent, and might well have been quoted as a reference. The discussion of magnetic leakage starts well; but it leads into calculations, based on artificial assumptions, which are of interest chiefly as exercises in the integral calculus; surely empirical methods would be used in practice? A chapter on quantum theory is in strange company; the approach used in academic atomic physics is inconsistent with the engineering outlook of the rest of the book, notably the Preface which says that "magnetism is fundamentally due to electric currents."

Most of the diagrams are good and clear, but they have no titles, and many of them therefore compel a search through the text to discover just what is being illustrated; perhaps this is intentional, but it is irritating in a reference book. The author's English is sometimes careless and sometimes inflated. Here, then, is a book that is worth having, but not as good as it easily might have been.

A. C. L.

# Notes and Comments

## Recent Awards

The Board of Editors has learnt with great pleasure of the honour recently conferred upon the following member of the Engineering Department :—

Lincoln Telephone Area	Jackson, F.	Technician Cl. IIA	Lieut.-Commndr. R.N.V.R.	Officer of the Order of the British Empire
------------------------	-------------	--------------------	-----------------------------	--

## New Year Honours

The Board of Editors offers congratulations to the following members of the Engineering Department honoured by H.M. the King in the New Year Honours List :—

Engineering Department	..	Hillman, W. J.	..	Technical Officer	..	..	British Empire Medal
Engineering Department	..	Unitt, A. T. G.	..	lately Motor Transport Officer, Cl. I	..	..	Officer of the Order of the British Empire
London Telecomms. Region	..	Brockwell, A. H.	..	Inspector	..	..	British Empire Medal
Swansea Telephone Area	..	Coles, W. H. A.	..	Inspector	..	..	British Empire Medal
Tunbridge Wells Telephone Area	..	Scott, F. W.	..	lately Technician	..	..	British Empire Medal

## Sir Thomas Purves

We regret to record the death of Col. Sir Thomas Fortune Purves, which occurred on 29th January, in London, in his seventy-ninth year.

Sir Thomas entered the Civil Service in 1889, and transferred in 1892 to the Post Office Engineering Department, in which he had a most distinguished career, culminating in his appointment in 1922 as Engineer-in-Chief. He held this position for ten years, at a time when rapid technical development was providing the means for linking up distant towns in Great Britain and on the Continent by means of a network of trunk cables, and for setting up a world-wide radio communication service. He will be remembered at home and abroad for the ability with which he directed the application of these developments, as well as for the leading part he played in bringing about the introduction of automatic switching in the local telephone field.

A knighthood was conferred on him in 1929, and in the same year he was elected President of the Institution of Electrical Engineers.

On retirement from the Post Office in 1932, Sir Thomas became Managing Director of United Telephones, Ltd., and later, Director of the Cable Makers' Association, a position which he held until retirement in 1948.

## Mr. L. G. Semple

Mr. L. G. Semple, at one time Chief Regional Engineer, Home Counties Region, was promoted (*in absentia*) to Regional Director, North Eastern Region, in 1945, while seconded to the Control Commission, Germany, as Controller-General, P. & T. Division. It is regretted, therefore, that in the last issue of the Journal a notice appeared indicating that this promotion was of recent date, and apologies are offered for the error.

# Institution of Post Office Electrical Engineers

## SUBSCRIPTIONS DEDUCTED FROM OFFICIAL SALARY

### CHANGE FROM ANNUAL TO MONTHLY DEDUCTIONS

Most members of the I.P.O.E.E. have agreed to avail themselves of the facility afforded by the Department of having their Institution subscriptions deducted from official salary, an arrangement which is of convenience both to individual members and to the Institution as a whole. Under the existing method, members' subscriptions are deducted in one sum annually during the June salary month.

The methods by which subscriptions to various National or Departmental organisations—such as the I.P.O.E.E.—are deducted from pay, have recently been considered by the Treasury, and it has been found that deductions can be more easily dealt with at the pay

centres if the amounts are resolved into monthly sums. To meet the Treasury recommendation, the Council of the Institution has agreed that from the beginning of the 1950/1951 Session, I.P.O.E.E. subscriptions which are deducted from official salaries shall be deducted at monthly rates instead of by one annual sum. The total amount of the annual subscription will remain unchanged for all classes of the membership.

As from the 1st April, 1950, the annual 17s. 6d. subscription due from the class of Member will be deducted at the rate of 1s. during the month of April, and 1s. 6d. each month during the months of May to March inclusive. The annual 15s. subscription due from the classes of Associate Member and Associate will be deducted at the rate of 1s. 3d. each month during the months of April to March inclusive.

(Continued on page 59)

# Regional Notes

## Midland Region

### GROWTH OF TREE ROOTS IN 4-WAY DUCT

Following a fault on the Birmingham-Ashby M.U. cable, an attempt was made to rod a spare way in the 4-way duct preparatory to drawing in a length of cable for the temporary repair. Rodding operations were, however, unsuccessful and an interruption length was laid overground to restore service. When the faulty length was withdrawn further attempts were made to rod. It was found that two spare ways were completely blocked and the way previously occupied by the faulty length was partially obstructed.

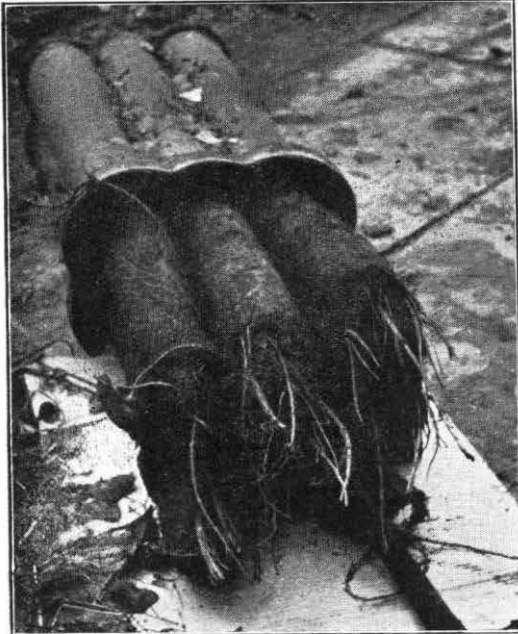

TREE ROOT FORMATION.

The ground was excavated to expose the duct track, one duct removed and the remaining ducts slipped back over the cables one at a time. It was then found that a root of a nearby willow tree had entered the joint between two ducts, grown into all four ways and the firing bore, and filled them with tightly packed fibrous root for a distance of thirty yards. Some idea of the obstruction caused can be obtained from the photograph which shows lengths of the fibrous root actually removed. The lengths have been inserted into a spare 6-way duct for illustration purposes.

E. S. L.

## Scotland

### STORM DAMAGE IN THE HEBRIDES

A snowstorm of unusual severity, accompanied by violent lightning, swept over Lewis and Harris in the Outer Hebrides on Friday, 9th December, 1949. Peat bog is common in the Islands, the result being that with the heavy wind and ice-loading some 200 poles were badly deflected and seven miles of junction route and 200 miles of wire will need complete rebuilding.

Several exchanges were isolated. At Callanish (famous for its Druid Standing Stone Circle), the D.P. snapped

and the leading-in cables pulled the entire window frame out of the Post Office building—much to the consternation of the Postmaster.

The main object of this note is to give some idea of the difficulties to be faced in emergency restoration work on islands. All available Wire, C.C. 70 lb P.V.C. Army-type

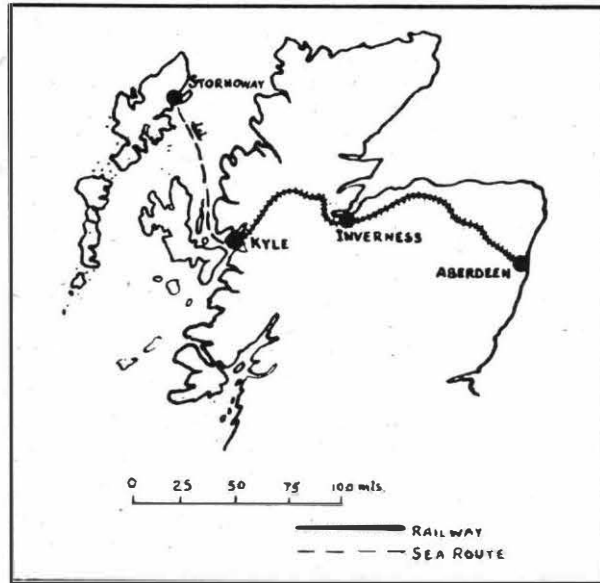

MAP SHOWING ACCESS TO STORM DAMAGE AREA.

and interruption cable was despatched from Aberdeen to Kyle of Lochalsh (200 miles) in two special vans attached to the first available passenger train. A landslide affecting the railway line resulted in the vans being two days en route. Fortunately, 16 miles of P.V.C. had been sent to Kyle of Lochalsh by Departmental road transport and one ton of 150-lb. copper and some interruption cable had reached Kyle by an earlier train from Inverness. This material was shipped to Stornoway without delay and filled the breach until the main consignments arrived. Two external construction gangs working in Skye were transported by road and ferry to Kyle where they were met by an Inspector from Inverness. The party joined the Kyle-Stornoway steamer and embarked upon a rough 70 mile sea journey across the Minch to reinforce the resident maintenance and construction staff in Stornoway.

All stores had to be shipped via Kyle which proved to be a veritable bottleneck—the daily steamer being capable of taking only a limited quantity of freight in addition to its usual cargo of essential foodstuffs, mails, etc., for Lewis. The result was that in spite of strenuous efforts on our part it was the following Tuesday night before any appreciable quantity of interruption cable reached the island and the stores from Aberdeen, together with supplies of cable and wire from Depot, piled up on the dock side. In the end the local staff at Kyle had to sort out the items most urgently required and ensure that they obtained priority of shipment.

The Army-type wire was found to be extremely useful in effecting temporary restoration of service; being wound double with approximately one loop mile per drum, paying out was a speedy process. The joints were kept well clear of the ground. The only difficulty so far experienced has been that the island sheep—voracious animals—seem to have a liking for the P.V.C. insulation.

H. J. R.

## Home Counties Region

### " TESTS AND PESTS "

With the systematic inspection of pole routes and the consequent increase in pole renewals, a great deal of interest has been paid to the decayed portions of timber. On cutting a decayed section from the sound timber, it was noted that the affected portion had been extensively honeycombed. Further examination revealed that a large grub had been thriving on the wood decay and, as a matter of interest, it was passed to the Essex Institute of Agriculture at Writtle, near Chelmsford.

A report has been received from the British Museum that the larva is in the group of the largest British Longhorn beetle, known to zoologists as "Prionus Coriarius." It is uncommon for telephone pole wood to be infected by this larva and doubtless it came from some nearby infected tree stump.

A further item of interest covers the use for odd lengths of stainless steel aerial cable. On a number of occasions the local cabling network at a large well-known factory had been affected by rodents, which damaged the lead cable where it leaves the internal cable chase to a 2-in. pipe leading to a joint box. The damage was always at the point where the cable enters the pipe, which had been effectively sealed, and it was thought that the rats on being poisoned attempted to follow the cable route in search for water.

In spite of the efforts of the management to dispose of the rats, some effective measure was necessary to prevent disruption of the telephone service, and the trouble has been satisfactorily cleared by renewing the faulty cables with odd short lengths of stainless steel aerial cable at the point where the lead cable had been continually affected.

L. G. H.

## South-Western Region

### BOURNEMOUTH AUTOMATIC AREA

The first stage of conversion to automatic working was completed successfully on 30th November 1949. General restriction on new buildings explains a modest commencement with two satellite exchanges and a tandem exchange, the latter installed in the building used for the Telephone Manager's Offices. A third exchange is due for conversion to satellite in 1952. Although plans for solution of a thorny problem at the Central exchange, Bournemouth, are well advanced, the date for completion is in the lap of the Ministry of Works! Bournemouth multi-office area thus becomes the first to be provided with multi-metering on conversion from manual, but as the tandem exchange has no subscribers' multiple the provision of non-metering relay sets is adequate for the equipment fitted in this building; nevertheless, in the allocation of dialling codes the standard arrangement for non-director areas has been made. The absence of multiple at the tandem exchange gave rise to a number of problems affecting the service circuits in the same building, particularly to the maintenance control which was, in common with all other service lines in the building, connected to the Central (Bournemouth) exchange, the latter retaining manual working initially.

The conversions at Boscombe and Canford Cliffs have been effected in each scheme as a turn-round in the existing buildings, and the temporary alterations to manual equipment and cable racking in the apparatus rooms to permit a satisfactory layout of the automatic plant called for much ingenuity. Subsequent to the transfer the maximum precautions were taken to prevent dispersal of dust to the automatic equipment by the use of vacuum cleaners and dust sheets (the close proximity

of new and old equipment prevented the erection of partitions).

Efforts are being made to make the maximum use of the automatic equipment already provided and hopes for further extension are maintained but, with 23,000 working lines within a 5-mile radius of the main exchange, the task ahead remains formidable. M. C. S.

## Welsh and Border Counties Region

### TENBY-CALDY RADIO TELEPHONE LINK

For some considerable time the necessity has been felt for a reliable means of communication between the Island of Caldy and the mainland. Communication has been provided in the past by means of a submarine cable which was abandoned and then by the Coastguards working by medium wave R/T to the Coastguards at Tenby. This method has proved unsatisfactory, due to the difficulty of maintaining a continuous watch.

A decision was made by Headquarters early in 1949 to install, at Tenby and Caldy, terminals of the new V.H.F. inter-island telephone equipment on an experimental basis for six months. If satisfactory operation was obtained, the Area would take over complete maintenance.

A full description of the equipment has been given by Messrs. Hollinghurst and Sowton in the paper on "V.H.F. Communication," delivered to the I.E.E. in 1949. It is sufficient to state that it is entirely battery-operated from dry and wet Leclanché cells which, with normal operating conditions, will give a life of approximately four months. Facilities are provided for C.B. and auto-signalling and supervisory.

The Area was asked to co-operate with the Engineer-in-Chief's Radio Branch on the installation in October, 1949. Equipment accommodation was found at Caldy in the basement of the "Chapel of Our Lady" and at Tenby in the roof space. The aerials, a dipole with reflector at Caldy, were mounted on a 24-ft. medium pole, which forms part of the overhead 2-wire route to Caldy Sub Post Office. At Tenby they are mounted temporarily on a steel roof standard.

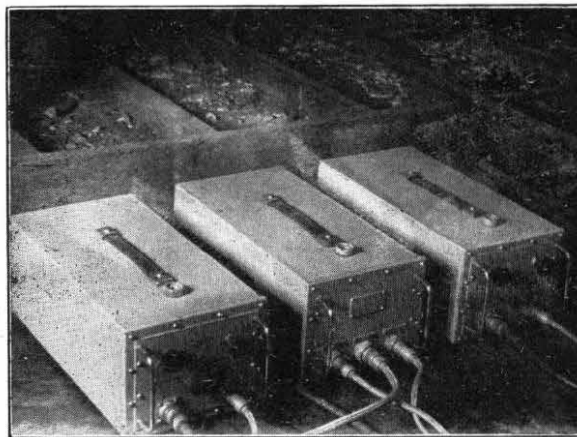

RADIO EQUIPMENT FITTED IN ROOF SPACE.

The installation was completed by the end of October and, after some experimental work, was opened for public service on the 7th November, 1949. The popularity of the circuit has exceeded all expectations, and during the months of December and January, 464 outgoing and 218 incoming calls were passed from and to the Caldy S.O. The signal-to-noise ratio of the circuit is sufficiently high to allow calls to be extended to the

Inland and Continental trunk networks with satisfactory results.

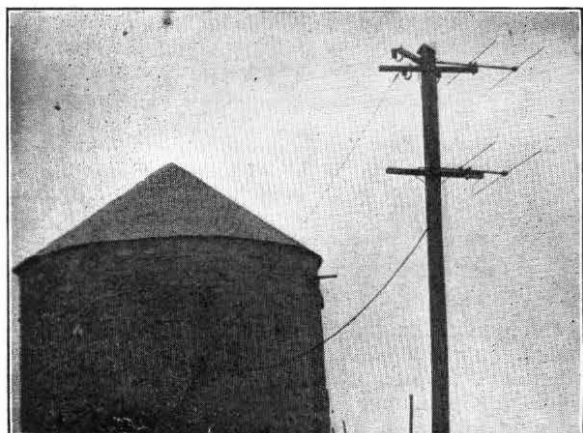

DIPOLE WITH REFLECTOR AT CALDY.

The fault liability of the equipment has proved to be reasonably low and it is expected that maintenance will be handed over to the Area in May of this year.

Caldy is so well known that the successful establishment there of the first-ever public telephone circuit of this type is worth reporting.

E. M. B.

### North-Western Region

#### LIVERPOOL.—KIOSK CONSTRUCTION

Delays in organisation at one time made the provision of telephone kiosks a protracted operation, and at the beginning of 1948 the whole of the arrangements were examined with a view to reducing such delays to a period more in keeping with the length of time it takes to do the actual work. The first stage was in the co-ordination of the siting proposals so that the Sales, Development, and Electric Light and Power Groups could determine the site in conjunction with the Surveyor and the Electricity Authority with a minimum of correspondence.

Originally, after the site was determined, the kiosk fabric was erected and instructions were passed for the connection of electric light cable and telephone wires, and the kiosk was put on the list for painting. In this way, the kiosk would stand idle for three months or more, waiting the provision of services before the equipment could be installed, and the appearance was a direct invitation to the rougher elements to smash the windows. During the course of the investigation, it was also found that as much as thirty-five pounds was charged by the Electricity Authority to arrange for the disconnection and reconnection of the electricity supply when a kiosk was being renewed, due to the special precautions necessary when there is any delay between demolition and reconstruction. It was decided to approach the Local Authority to agree on adopting a new method which would leave the fuse box supported on a template with the fuses withdrawn during renewal.

The ultimate plan, therefore, was to set up a paint factory for the painting of assembled kiosks which, after being fully equipped with electric light and telephone equipment, would be transported to the site and by the use of a rapid hardening cement be brought into service on the same day, whether the site was new or whether the kiosk was to be placed in the same position as one demolished.

This plan was developed in stages. Firstly, the fabric of new kiosks was painted unassembled in the paint shop and transported to the site, where it was erected and finished off with red putty. The Local Electricity Authority received the suggested method of change-over with avidity, and the initial experiment in the centre of Liverpool was an unqualified success. The old kiosk was demolished and the new one erected and brought into service in twelve hours—time being reckoned from leaving headquarters to returning. The staff employed was a three-man kiosk erection gang, installation fitter and E.L. & P. fitter.

The problem of transporting a completed kiosk has not been solved so rapidly. All the known methods of transportation possess some material disadvantage in that the manoeuvrability or safety of the carrier leaves something to be desired. However, a device for lifting cable drums was seen at a local factory and the general principles of its design were put to the mechanics' shop. The mechanics immediately got busy on improving this design and two suggestions were submitted, one of which adopted a form of eccentric loading and shows great promise of ultimate success. The device involves the use of stub axles supporting a trailer framework. The loading platform for the kiosk is L-shaped, the base of the L supporting the base of the kiosk, and the vertical supporting the side of the kiosk. This platform is hinged near the centre of the vertical at the centre of gravity of the combined load, and the hinge is supported by an inverted carriage spring with shackles fixed to the trailer chassis. With the trailer in the horizontal position, the hinge is vertically in line with the stub axles. Lifting the arm of the trailer at the forward end moves the hinge in an arc relative to the axle and so lowers the L-platform

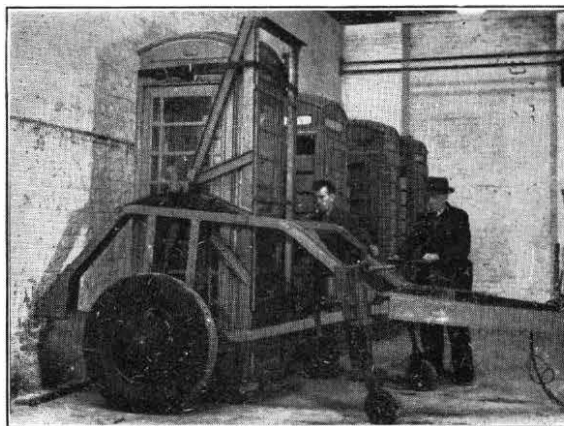

THE KIOSK CARRIER.

about three inches. Restoring the trailer arm to normal thus lifts the platform three inches. If the kiosk is erected on battens, the platform can be pushed under the base and the kiosk lifted for transportation. During transportation, the kiosk is carried at an angle of about 30° to the horizontal with the L-platform locked in that position. Placing the completed kiosk on site should then present little difficulty as the process of loading is simply reversed, and the kiosk can be set down on the foundation bricks prior to cementing.

The trailer has now been completed and preliminary trials on a few kiosks have shown that with an adequate kiosk programme a considerable saving of labour will result.

W. F. D.

# Junior Section Notes

## Bath Centre

On the 12th January, 1950, a Junior Centre was formed in Bath, to cover, Bath, Chippenham and Wells Maintenance Areas. The membership reached the 30 mark immediately and is expected to be higher as the Centre becomes better known. Especially we should like support from the Chippenham, Q.Q.C.C. and Q.S.W.C. staffs.

The officers and committee appointed are :—

*Chairman* : S. A. R. Packer ; *Vice-Chairman* : A. L. Mainstone ; *Secretary* : G. A. E. Buckley ; *Treasurer* : K. H. Wonson ; *Committee* : J. Spicer, W. Read, J. E. Hawker, J. Vranck, R. E. Otridge.

The Committee hope to arrange monthly meetings and visits to places of scientific interest, and to this end contact has been established with a number of firms and individuals in the district.

Your support will make the work of the Committee easier and ensure a varied and interesting programme. All interested should contact a member of the Committee for full details of the Centre's activities. G. A. E. B.

## Bradford Centre

The 1949-50 session opened on the 11th October, 1949, and a survey of the events up to the end of that month has already appeared in the Journal.

On the 15th November, Mr. G. Woodhead read an excellent paper on "Town and Country Planning," which was followed by a lively discussion. The paper was illustrated by lantern slides devised by Mr. Woodhead, and much information about a subject which concerns us all was imparted.

The 17th November, 1949, was the occasion of a Film Show and "Demonstration of a Model Locomotive," built by Mr. J. K. Scarth of the Bradford Model Engineers' Society. Mr. Scarth was assisted in the lecture and demonstration by Mr. C. Thornton, also of the B.M.E. Society. This was one of the most interesting and enjoyable meetings of the session.

On the 15th December a talk and demonstration on "Amateur Radio as a Hobby" were presented by the Bradford Telephone Area Sports and Social Club, Radio Section. This again was a very noteworthy meeting.

On 21st November, visits were made to the Bradford City Police "999" and Radio Central Station. All who attended agreed that "crime does not pay."

A milestone in the Centre's march of progress was reached on the 27th January, 1950, for this was the occasion on which we managed to defeat a very gallant team at Scarborough in a "Quiz Competition" conducted in our respective meeting places over amplified lines. The score was Bradford 31, Scarborough 27; this was really a big surprise to us as we had been given to understand that Scarborough were invincible, but perhaps the fact that, departing from usual procedure, we held this meeting in "The Market Tavern" and had fortified ourselves with sandwiches, etc., had an effect on our team! A very enjoyable evening was spent both by us and Scarborough, and a return match will certainly be one of the attractions of next session's programme. Our thanks are extended to Scarborough for issuing the challenge and for co-operating to give us a jolly evening. Several senior members, including Mr. J. W. Barratt, the Regional Liaison Officer, and the Telephone Managers of Bradford and York came along and joined in the fun. All agreed that Departmental life and terms can have amusing sides even though we are apt to overlook them sometimes. These contests are recommended to other

Centres, and Bradford is willing to challenge any other N.E. Region Centre.

At the time of writing these notes the programme for the remainder of the session was as follows :—

14th February, 1950.—Radio Control for Model Aircraft—Messrs. W. D. Priestly & H. T. Delaney.

16th March, 1950.—The Area Contract as Applied to the Erection of Cabinets and Pillars—Mr. A. Entwistle.

30th April, 1950.—Mechanical Aids—Mr. J. Peace.

31st May, 1950.—Annual General Meeting.

Suggestions for further visits and offers of short papers or talks will be welcomed by the Committee and will assist greatly in planning next year's programme.

A. E.

## Brighton Centre

The following are the officers for 1949-50 :—

*Chairman* : K. W. Chandler ; *Vice-Chairman* : F. G. Anderson ; *Secretary* : R. F. J. Beddis ; *Librarian* : C. James ; *Committee* : Messrs. Beckett, Hulse, Mahood, Moore, Pitt, Pope, Kochelle, Trist.

Three meetings have been held, which have all been satisfactorily attended. Mr. H. M. Wells gave a lecture on picture telegraphy with excellent demonstrations of the apparatus used. Colonel C. E. Calveley's talk on "Staff" produced a very good discussion and Mr. F. T. Carwin, a local member, gave an excellent outline of Local Line Planning.

The remainder of the programme was :—

4th January.—After 25 Years—B. C. A. Stone.

1st February.—Modern Developments in Local Line Planning—R. M. Richards.

1st March.—Future Development in our Area—F. N. Charles.

The Annual General Meeting and Chairman's Address will be on 5th April, 1950.

## Cambridge Centre

The centre was revived at a meeting held on 30th December, 1949, and the following officers were elected :—

*Chairman* : L. A. Salmon ; *Vice-Chairman* : H. W. Haworth ; *Secretary* : J. P. Wearn ; *Treasurer* : B. S. Cranfield ; *Committee* : L. R. Andrews, J. S. Manning, F. J. Davies.

The programme for the opening session was as follows :—Lecture: "Astronomy," by R. C. T. Warboys ; Visits to University Observatories and to University Elec. Eng. Lab.

The Annual General Meeting, with Film Show, will be held in May, 1950.

## Chichester Centre

The officers are as follows :—

*Chairman* : W. C. Jackson ; *Vice-Chairman* : B. G. Ifould ; *Secretary* : R. W. Smith ; *Treasurer* : A. T. Yardley.

The membership is good considering our very scattered area and meetings have been interesting with good discussions. We have had papers on "I.C. Engines," by K. B. Salmon ; "Progress of the Telephone," by Mr. Carr ; "Clocks, Mechanical and Electrical," by N. L. Fletcher ; "Radio Interference," by N. Churcher ; and we are looking forward to a visit to the National Physical Laboratory.

## Darlington Centre

Programme arrangements for the 1949-50 session were completed without difficulty and no excuses were offered by the Committee in submitting the following :—



11th October, 1949.—Carrier, Without Tears—Mr. G. B. Hart, A.M.I.E.E.

8th November, 1949.—Introduction to Atomic Energy—Mr. A. J. Shiell, B.Sc.

13th December, 1949.—U.A.X.s Simplified—Mr. G. Dale.

10th January, 1950.—Development and Planning—Messrs. R. V. Heppinstall and J. W. Brown.

7th February, 1950.—Amateur Radio—Mr. R. Dodds.

7th March, 1950.—The North-Eastern Electricity Board—Mr. T. E. Daniels, M.Eng., M.I.E.E., M.I.Mech.E.

18th April, 1950.—Annual General Meeting.

Expressions of appreciation of the talks given to date—by members and visitors—have been most encouraging to the Committee.

Visits to various works, etc., have also proved to be very popular.

On 9th November, 1949, the Centre arranged for parties to visit three collieries in the district and full advantage was taken by members, and visitors who attend monthly meetings, to whom we extended invitations.

Suitably garbed for the occasion they were conducted into the bowels of the earth and all the hazards of a miner's life below were brought home to them—in fact, one party, including the Area Engineer (Mr. A. C. Pitcairn) had to crawl on all fours through a 2-ft. seam to the coal face. A modern acquisition—the electrical coal cutter—was seen in operation, as also were other devices used in this underground industry. The experience created a profound impression and a higher respect for another man's job—coal mining.

The Darlington Power Station was the next port of call.

Congratulations to Middlesbrough Centre in arranging a visit from our President (Mr. H. R. Harbottle) on 16th February, 1950.

It is regretted that he will be unable to visit the Darlington Centre, too, but it is hoped that a representative number of members will be in attendance, and that it will be as successful as when our previous President (Mr. D. Smith) came to Darlington to mark the first visit of the President to a Provincial Junior Centre.

The recent suggestion to set up a "Junior Section Forum" in the *I.P.O.E.E.* Journal is welcomed, and it is thought that such a departure would lead to an exchange of views by various Centres to the common good of the Junior Section.

The Darlington Centre would like to read in this "Forum" the opinions of other centres as to how they think recognition could be given to a member who gives a talk without a paper—to enable him to participate in the competition sponsored by the Council of the Parent Institution. How could he be assessed and by whom? If this could be decided then the Council could be approached to amend the rules which only allow a paper prepared in advance and read at a meeting to qualify.

The opinion of our Committee, in the light of experience, is that greater credit is due to a member who can say his piece without the written paper.

C. V. H.

### Doncaster Centre

On 1st December a trans-area quiz was held between Lincoln and Doncaster Centres. A 4-wire circuit was used, terminated at each end by microphones and loudspeakers.

Doncaster made off to an excellent start but at the end of the second half Lincoln had drawn equal. Both

teams expressed a desire to play on in the hope of reaching a decision, but after two extended periods the scores were still equal. The match was, therefore, drawn.

It is hoped that the winners of the replay will compete for the Area Championship against the winners of the forthcoming Grimsby v. Scunthorpe quiz.

Mr. J. W. Barratt, A.M.I.E.E., was umpire, and question-masters were Mr. J. Willmot (Doncaster) and Miss Wall (Lincoln).

Teams were, Lincoln: Messrs. R. Found, T. Mullins, L. Reames, L. Burkilt, E. Smith and W. Barnes; Doncaster: Messrs. C. Gaunt, J. Barber, L. Hayes, K. Grainger, D. Perkins and J. I. Lawson. J. I. L.

### Dundee Centre

The first meeting of the 1949-50 session was held on the 8th November in the Conference Hall, Telephone House, Mr. J. Knox, M.Sc., A.M.I.E.E., Area Engineer, giving an interesting and informative lecture, the subject being "The Shape of Things to Come."

At the close of the lecture the Annual General Meeting took place, and the following office-bearers were elected:—

*Chairman*: A. C. Gow; *Vice-Chairman*: W. G. Craig; *Secretary*: D. MacTaggart; *Treasurer*: J. Lettice; *Committee*: D. D. Watson, J. O. Pavey, K. K. Summers, J. A. Lamb and W. T. McCall.

At our last meeting, Mr. D. B. Wright, of Messrs. Larg & Sons (Dundee), Ltd., dealt with the subject of "Television" from its inception to present-day potentialities.

The remainder of the programme was as follows:—

17th January.—Dial 999—Mr. Gamble.

14th February.—Film Show.

14th March.—Quiz.

18th April.—Open Night and A.G.M.

It is pleasing to note that attendances have been good, and it is our intention to increase the interest of the staff in our activities. D. M.

### Maidstone Centre

The following officers were elected at the Annual General Meeting:—

*Chairman*: G. T. Cheeseman; *Secretary*: C. Tame; *Treasurer*: R. W. Wallond; *Committee*: Messrs. Barham, Borrowes, Shaw, Garrod, Lager and Beckett.

The first meeting was a lecture on "Lens manufacture," followed by a visit to the Hanwell Optical Co. works where Mr. Johnson gave a fine insight into the practical side of lens manufacture. The next two meetings were on "Carrier Telephony Systems," by Mr. Regan, followed by Mr. Casey's paper on "Electrical Calculators."

The remainder of the programme comprised: "Main Line Planning," by F. C. Haliburton; "Aircraft Engines" (Piston and Jet); and "Electricity Distribution," by E. G. Pope; the Annual General Meeting will be held on 3rd April.

### Middlesbrough Centre

It is pleasing to note that enthusiasm has been maintained, as shown in the increased attendances at the meetings.

17th November.—"Local Line Planning," by R. V. Heppinstall proved to be a most enjoyable lecture. An introduction by Mr. C. R. Harrison covering the aspect of Sales Division, hitherto an unknown quantity to many

of our members, was a most interesting approach to the subject.

15th December.—“Notes on Sound Reproduction,” by Mr. H. C. Naylor, A.M.I.E.E. He gave demonstrations which included performance of gramophone pickups on test and ordinary records, and the reproduction of sound—with and without frequency restrictions—in a loudspeaker and on an oscilloscope.

19th January.—The lecture on Television, to be given by Mr. B. V. Northall, was postponed until a later date, due to an unfortunate accident involving Mr. Northall. We were fortunate, however, in obtaining the services of Mr. R. Dodds who, at short notice, offered to lecture on “Radar.”

By the time these notes are in print we will have had our President (Mr. H. R. Harbottle) at one of our meetings, 10th February, 1950, to give us a lecture on “The Main Phenomena of Hearing and Their Bearing on the Design of Telephone Communication Systems.” We greatly appreciate his help and interest in us and also the assistance given by our Liaison Officer (Mr. J. S. Gill) in making such a lecture available to us.

In a recent circular issued by the Secretary of the Senior Section it was suggested that the publicity of the Junior Section in the Journal could, with advantage, take the form of a Junior Section Forum. In the October, 1949, issue of the Journal, Mr. Harbottle in his article outlined the Junior Section’s past achievements and future responsibilities. It is not much use dwelling in the past so then what of the future? How are we going to get that desired lively interest and make full use of the opportunities available to us? Plenty will discuss a football match or even an orchestral concert, but not so many are to be found to discuss in the right place—Junior Centre meetings—telecommunications and allied subjects. At a local technical college “Prize Day” one speaker took up the theme of training on the lines of the following:—

1. Character—Human relations.
2. Skill, resulting in pride of one’s work and loyalty to one’s employer.
3. Technology.
4. General education—learn as much as you can about as much as you can.

May it be suggested that we assist in all the four points but by informal means. Whilst Mr. Harbottle emphasises the “Local Centre” aspect of discussions, and we heartily agree, perhaps interest could be created on a “National” basis. As will have been observed in the Journal, we have given information of the activities of our Centre. This may have been of some help to less flourishing centres. We enjoy and look forward to the reading of activities of other centres. The Board of Editors of the Journal has promised us space so long as a regular supply of material is submitted. Why don’t we all take advantage of this opportunity? We would be pleased to correspond direct with other centres on a number of suggestions which we have in mind. We all work for the same firm and have common interests, so why don’t we get to know one another a bit more? Not all of us go on training courses. We could discuss each other’s problems and let each other know the results of our deliberations. Great fun as well as educational benefit is seen in the idea. May we hear from other centres either through the medium of the Journal or direct to J. Brown, c/o Telephone Manager’s Office (Room 100), Marton Road, Middlesbrough.

J. B.

## Portsmouth Centre

The following officers were elected at the Annual General Meeting:—

*Chairman*: V. Trowbridge; *Vice-Chairman*: F. Warner; *Treasurer*: E. D. Koughan; *Secretary*: W. Forward.

An attractive programme was arranged for the second half of the session as follows: Lecture at St. Mary’s Hospital on the apparatus associated with mass-radiography; Visit to Pirelli-General Cable Works; Lecture on “Electronics in Modern Industry,” by W. Bacon and a conducted visit to H.P.O. Auto-Exchange and Repeater Station.

The concluding meetings are: 11th April, Films; and 26th April, Annual General Meeting.

## Scarborough Centre

The Annual Dinner Concert was held on Friday, 9th December, 1949, and a splendid evening was enjoyed by all present.

Among the many senior members who attended were the Regional Director, Mr. L. G. Semple, and the Telephone Manager, Mr. H. A. Clibbon, who both made short speeches which were humorous, instructive and well appreciated. After an excellent dinner, the concert started and the fun was fast and continuous. Eighty-five members and friends attended and the Centre Officers and Committee wish to thank all who contributed to the success of the evening, including the guests who so kindly accepted our invitation and helped us in no small way to make a success of our “Annual.”

On Friday, 27th January, 1950, the first inter-Area quiz competition was staged against Bradford. The Telephone Manager, Mr. H. A. Clibbon, broadcast to Bradford and extended greetings, and amongst other interesting remarks touched upon the work that had obviously been done beforehand by both Areas in connection with the evening’s entertainment, and said that the event could well be described as a “Joint Production.” Mr. H. S. M. Hall, the Telephone Manager, Bradford, responded suitably and the quiz was on.

The competition was eventually won by Bradford, who were worthy winners by a small margin. The evening’s entertainment was finally ended at approximately 10 p.m. with Bradford extending a return date to Scarborough, which was promptly accepted. It was pleasing to see so many Senior members present, and in conclusion may we ask if there are any other Branches or Areas in the Region that would care to accept our friendly challenge to a quiz competition? If so, Scarborough is waiting.

Come on the Junior Section!

A. B. C.

## Tunbridge Wells Centre

The centre has been revived with the following officers:—

*Chairman*: A. E. Chapman; *Secretary*: E. L. English; *Treasurer*: J. P. Lawrence; *Committee*: Messrs. Kingswood, Hasted, Waddell, Shoebridge, Johnson and Edwards.

The programme for the session covered “Trunk Telecommunications in India,” by G. M. Blair; a Visit to Fulham Power Station; “Introduction to Coaxial Transmission,” by G. F. Arnold and A. Peters and a “Scientific Quiz.” The session concluded with a visit to Mount Pleasant Sorting Office.

# Staff Changes

## Promotions

Name	Region	Date	Name	Region	Date
<i>Area Engr. to Asst. Staff Engr.</i>			<i>Prob. Engr. to Engr.—continued</i>		
Couch, P. R. ..	N.E. Reg. to E.-in-C.O.	22.1.50	Horsfield, B. R. ..	E.-in-C.O.	1.12.49
Ward, W. C. ..	Mid. Reg. to E.-in-C.O.	26.2.50	Tattersall, R. L. O. ..	E.-in-C.O.	1.12.49
<i>Area Engr. to Tel. Man.</i>			Froom, R. P. ..	E.-in-C.O.	1.12.49
Mayne, E. A. ..	Stoke	1.12.49	Haworth, J. E. ..	E.-in-C.O.	1.12.49
<i>Engr. to Area-Engr.</i>			May, C. A. M. ..	E.-in-C.O.	5.1.50
Palk, E. ..	L.T. Reg.	4.1.50	Hill, L. W. ..	E.-in-C.O.	5.1.50
<i>Prob. Engr. to Engr.</i>			Burton, R. N. ..	E.-in-C.O.	5.1.50
Bastow, F. J. ..	E.-in-C.O.	17.11.49	Hudson, G. K. ..	E.-in-C.O.	5.1.50
Bishop, D. K. ..	E.-in-C.O.	7.11.49	Vernon, D. H. ..	E.-in-C.O.	19.1.50
Bourne, K. W. ..	E.-in-C.O.	8.11.49	<i>Asst. Engr. to Engr.</i>		
Finnamore, A. J. ..	E.-in-C.O.	5.11.49	House, L. F. ..	S.W. Reg.	3.1.50
Hughes, H. S. ..	E.-in-C.O.	13.11.49	Hutchings, W. S. ..	L.T. Reg.	7.1.50
Lewis, T. A. ..	E.-in-C.O.	2.11.49	Plant, F. ..	N.W. Reg.	21.1.50
Wray, D. ..	E.-in-C.O.	5.11.49	Brown, W. D. ..	W.B.C. Reg. to L.T. Reg.	1.2.50
Wade, C. D. ..	Scot.	24.11.49	Fable, F. P. ..	H.C. Reg.	31.1.50
Partridge, J. G. ..	E.-in-C.O.	1.12.49	Bouquet, H. F. ..	E.-in-C.O.	3.1.50
Tod, D. S. ..	E.-in-C.O.	1.12.49	Lamb, A. H. ..	N.E. Reg. to E.-in-C.O.	3.1.50
Harris, L. R. F. ..	E.-in-C.O.	1.12.49	Batt, T. D. ..	H.C. Reg. to E.-in-C.O.	22.1.50
Baily, N. G. ..	E.-in-C.O.	8.12.49	Coulman, A. H. ..	E.-in-C.O.	1.2.50
Clinch, C. E. E. ..	E.-in-C.O.	1.12.49	<i>Tech. Off. to Asst. Engr.</i>		
Davidson, C. F. ..	E.-in-C.O.	1.12.49	Petchey, R. F. ..	E.-in-C.O.	7.11.49
Forster, A. E. T. ..	E.-in-C.O.	9.12.49	Springett, F. ..	E.-in-C.O.	7.11.49
Cobbe, D. W. R. ..	E.-in-C.O.	1.12.49	Charlton, K. D. ..	E.-in-C.O.	9.1.50
			Thraves, C. M. ..	E.-in-C.O.	23.1.50

## Transfers

Name	Region	Date	Name	Region	Date
<i>Asst. Staff Engr.</i>			<i>Asst. Engr.—continued</i>		
Edwards, J. J. ..	E.-in-C.O. to L.T. Reg.	26.2.50	Gerrard, H. ..	N.E. Reg. to E.-in-C.O.	2.1.50
<i>Engr.</i>			Edwards, H. W. F. ..	E.-in-C.O. to Australian P.O.	12.1.50
Hinchcliffe, J. D. ..	E.-in-C.O. to Min. of Supply	1.12.49	Sims, G. H. ..	E.-in-C.O. to Australian P.O.	24.11.49
Jemmeson, A. E. ..	Scot. to N.E. Reg.	1.1.50	Wright, J. E. ..	E.-in-C.O. to N.E. Reg.	9.1.50
Mayne, R. T. ..	E.-in-C.O. to N.E. Reg.	12.2.50	Butterworth, B. B. ..	E.-in-C.O. to P. & T. Dept. E. Africa (Previously seconded)	19.9.47
Lee, A. ..	E.-in-C.O. to Min. of Supply	15.6.49	Knight, E. D. ..	N.E. Reg. to Colonial Service (Previously seconded)	5.4.46
<i>Prob. Engr.</i>			McPherson, J. W. ..	L.T. Reg. to E.-in-C.O.	6.2.50
Saunders, J. C. ..	S.W. Reg. to Nigeria (Seconded)	17.12.49	Gannon, J. ..	E.-in-C.O. to N.E. Reg.	13.2.50
Burley, N. ..	E.-in-C.O. to N.E. Reg.	1.2.50	Norman, J. M. ..	E.-in-C.O. to P.R.D. ..	18.1.50
<i>Asst. Engr.</i>			Hope, S. ..	E.-in-C.O. to N.W. Reg.	27.2.50
Whitaker, T. H. ..	E.-in-C.O. to N.E. Reg.	9.12.49	Benford, H. ..	E.-in-C.O. to Mid. Reg.	1.12.49
Connell, D. R. W. ..	E.-in-C.O. to S.W. Reg.	1.1.50	<i>Asst. (Scientific)</i>		
Martin, A. C. ..	E.-in-C.O. to Nigeria (Seconded)	21.12.49	Guy, J. A. ..	E.-in-C.O. to Foreign Office	1.2.50
Millson, H. W. ..	E.-in-C.O. to Australian P.O.	18.12.49			

## Retirements

Name	Region	Date	Name	Region	Date
<i>Asst. Staff Engr.</i>			<i>Engr.</i>		
Morrish, H. E. ..	E.-in-C.O.	31.12.49	Humphreys, L. W. ..	L.T. Reg. (Resigned)	31.8.49
<i>Area Engr.</i>			Green, F. C. ..	L.T. Reg.	31.12.49
Gunston, J. A. ..	L.T. Reg.	31.12.49	Smith, J. G. ..	L.T. Reg.	31.1.50
<i>Exec. Engr.</i>			Ferris, J. H. ..	E.-in-C.O. (Health grounds)	19.2.50
Jacquest, A. H. ..	E.-in-C.O.	31.1.50	<i>Asst. Engr.</i>		
			Sands, J. L. ..	Mid. Reg.	31.12.49
			Andrews, H. H. ..	E.-in-C.O. (Health grounds)	3.12.49

**Retirements—continued**

Name	Region	Date	Name	Region	Date
<i>Asst. Engr.—continued</i>			<i>Inspr.—continued</i>		
McNeille, J. L. . . .	L.T. Reg. . . .	31.12.49	Parkinson, J. W. . .	N.E. Reg. . . .	31.12.49
Bouhey, S. H. . . .	L.T. Reg. . . .	31.12.49	McArdle, T. A. D. . .	N.E. Reg. (Resigned)	31.9.49
Levens, T. F. . . .	N.W. Reg. . . .	31.12.49	Oliver, W. . . .	N.I. Reg. . . .	31.8.49
Phipps, F. H. . . .	Mid. Reg. . . .	31.12.49	Heather, W. A. . . .	L.T. Reg. . . .	31.12.49
Taylor, G. W. . . .	Mid. Reg. . . .	31.12.49	Roach, H. C. . . .	S.W. Reg. . . .	31.7.49
Johnson, S. H. . . .	Mid. Reg. . . .	31.12.49	Groves, E. J. . . .	S.W. Reg. . . .	31.8.49
Kershaw, S. . . .	N.E. Reg. . . .	31.12.49	Hollerton, F. . . .	N.W. Reg. . . .	31.12.49
Frost, W. . . .	Mid. Reg. . . .	31.12.49	Moss, J. W. . . .	N.W. Reg. . . .	31.12.49
Prior, G. . . .	E.-in-C.O. . . .	31.12.49	Andrews, H. E. . . .	L.T. Reg. . . .	18.2.50
Norfolk, E. W. . . .	E.-in-C.O. . . .	31.12.49	Richards, C. A. . . .	L.T. Reg. . . .	31.12.49
McNabb, J. B. . . .	E.-in-C.O. (Resigned)	24.1.50	Frood, B. . . .	S.W. Reg. (Resigned)	31.12.49
Beer, T. . . .	W.B.C. Reg. . . .	3.2.50	Foster, A. T. . . .	L.T. Reg. . . .	20.8.49
Goodwin, E. W. . . .	W.B.C. Reg. . . .	31.7.49	Fox, R. R. . . .	L.P. Reg. . . .	23.10.49
Barker, J. . . .	L.T. Reg. . . .	31.1.50	Thatcher, A. C. . . .	L.T. Reg. . . .	18.12.49
Kinsella, L. B. . . .	L.T. Reg. . . .	20.2.50	Robertson, V. G. S. . .	Scot. . . .	20.11.49
Jeffrey, E. . . .	N.E. Reg. . . .	31.3.49	<i>Asst. Exper. Off.</i>		
Brierley, N. . . .	E.-in-C.O. . . .	18.2.50	Clarke, D. T. . . .	E.-in-C.O. (Resigned)	31.12.49
Lamont, K. . . .	E.-in-C.O. (Resigned)	28.2.50	<i>Temp. Asst. Exper. Off.</i>		
Pease, T. B. . . .	N.E. Reg. . . .	27.2.50	Gleed, K. E. . . .	E.-in-C.O. (Resigned)	31.1.50
<i>Inspr.</i>			<i>Asst. (Scientific)</i>		
Isaacs, R. . . .	Scot. . . .	31.12.49	Harrison (Mrs.), M. M. . .	E.-in-C.O. (Resigned)	27.1.50
Rowland, H. . . .	N.W. Reg. . . .	22.2.50			
Chambers, R. G. . . .	W.B.C. Reg. . . .	22.9.49			

**Deaths**

Name	Region	Date	Name	Region	Date
<i>Asst. Engr.</i>			<i>Asst. Engr.—continued</i>		
Cousens, A. J. . . .	L.T. Reg. . . .	12.12.49	Birkenshaw, T. . . .	N.E. Reg. . . .	4.2.50
Leyland, T. . . .	N.W. Reg. . . .	18.1.50	Snowling, J. W. . . .	E.-in-C.O. . . .	13.2.50
Armitage, H. . . .	N.W. Reg. . . .	17.1.50	Laing, D. M. . . .	Mid. Reg. . . .	17.2.50
Checkley, E. W. . . .	Mid. Reg. . . .	3.2.50			

**CLERICAL GRADES**

**Promotions**

Name	Region	Date	Name	Region	Date
<i>E.O. to H.E.O.</i>			<i>C.O. to E.O.</i>		
Ridland, L. . . .	E.-in-C.O. . . .	1.1.50	Gregory, H. I. (Miss) . .	E.-in-C.O. . . .	1.1.50
Duncan, W. B. . . .	E.-in-C.O. . . .	1.1.50			

**Transfer**

Name	Region	Date
<i>H.E.O.</i>		
Goodway, T. C. . . .	E.-in-C.O. to Min. of Fuel and Power	3.2.50

**Retirements**

Name	Region	Date	Name	Region	Date
<i>H.E.O.</i>			<i>H.E.O.—continued</i>		
Warden, J. G. H. . . .	E.-in-C.O. . . .	31.12.49	Ost, H. J. . . .	E.-in-C.O. . . .	31.12.49

## I.P.O.E.E.—(Continued from page 50)

Recent additions to the Institution Library include the following :—

- 1854 *Principles of Radar*. D. Taylor and C. H. Westcott (British 1948).

An exposition and survey of the principles underlying radar design, which indicates the common factors which underline the many types of radar equipment.

- 1855 *Technical Optics, Vol. I*. I. C. Martin (British 1948).

This volume deals with general matters, including a short introduction to the theory of spectacles, and is designed to awaken a living interest in the scientific aspects of the subject.

- 1858 *The Royal Signals Handbook of Line Communication, Vol. I*. (British 1947).

A comprehensive textbook dealing with the basic theory required for study of line communications and including a summary of the mathematics necessary for this. Reviewed in *P.O.E.E.J.*, Vol. 41, p. 233.

- 1862 *Refrigeration and Air Conditioning Guide*. E. P. Anderson (American 1948).

Prepared as a helpful service guide providing useful information covering all phases of modern mechanical refrigeration and air conditioning.

- 1865 *Elementary Telecommunications Practice*. W. T. Perkins (British 1948).

Covers the syllabus of the City and Guilds of London Institute examination. Reviewed in *P.O.E.E.J.*, Vol. 41, p. 227.

- 1866 *Mechanics and Applied Heat*. S. H. Moorfield and H. H. Winstanley (British 1948).

This book's object is to present in one volume a course in engineering science which will prepare a student for entry upon the final year of the Ordinary National Certificate Course.

- 1867 *Your Obedient Servant*. Institute of Public Administration (British 1948).

Being some reflections on correspondence between Government Departments and the Public.

- 1868 *Working Conditions in the Civil Service* (British 1947).

A report by a Study Group set up by the Treasury in 1943 to consider how the efficiency of the Civil Service might be increased.

- 1869 *Technical Literature*. G. E. Williams (British 1948).

This handbook is addressed chiefly to engineers and physicists, to assist them in preparing technical and scientific papers. Reviewed in *P.O.E.E.J.*, Vol. 41, p. 221.

- 1870 *The Presentation of Technical Information*. R. O. Kapp (British 1948).

A guide to the art of exposition.

- 1871 *Telephony, Vol. I*. J. Atkinson (British 1948).

A detailed exposition of the Telephone Exchange Systems of the British Post Office—General Principles and Manual Exchange Systems. Reviewed in *P.O.E.E.J.*, Vol. 41, p. 212.

- 1875 *Mathematics for Technical Students*. A. Geary, H. V. Lowry and H. A. Hayden—Part III (British 1948).

This series is designed to provide the basic mathematical equipment for technical students. Part III covers the third year of the National Certificate Courses in Engineering, Building and Chemistry.

- 1876 *Micro-Waves and Wave Guides*. H. M. Barlow (British 1947).

A special effort has been made in this book to capture the attention and interest in this subject. It is essentially practical, and gives the kind of explanation that is most satisfying and acceptable to the widest possible circle of readers. Reviewed in *P.O.E.E.J.*, Vol. 42, p. 98.

W. D. FLORENCE, Librarian

### BOARD OF EDITORS

- H. FAULKNER, C.M.G., B.Sc., M.I.E.E., Chairman.  
F. E. NANCARROW, O.B.E., A.R.C.Sc., M.I.E.E.  
P. B. FROST, B.Sc., M.I.E.E.  
A. H. MUMFORD, O.B.E., B.Sc.(ENG.), M.I.E.E.  
W. T. GEMMELL, A.C.G.I., B.Sc., M.I.MECH.E., A.M.I.E.E.  
W. WEST, B.A., M.I.E.E.  
D. A. BARRON, M.Sc., A.M.I.E.E.  
A. F. STOLLARD.  
G. E. STYLES, A.M.I.E.E., Managing Editor.  
W. A. HUMPHRIES, A.M.I.E.E.  
J. P. HARDING, B.Sc.(ENG.), } Assistant Editors.  
A.M.INST.C.E., A.M.I.E.E.  
A. J. HUTCHISON, Secretary-Treasurer.

### Copyright

The entire contents of this JOURNAL are covered by general copyright, and special permission is necessary for reprinting long extracts, but Editors are welcome to use not more than one-third of any article, provided credit is given at the beginning or end thus: "From the *Post Office Electrical Engineers' Journal*."

The Board of Editors is not responsible for the statements made or the opinions expressed in any of the articles in this JOURNAL, unless such statement is made specifically by the Board.

### Communications

All communications should be addressed to the Managing Editor, *P.O.E.E. Journal*, Engineer-in-Chief's Office, Alder House, Aldersgate Street, London, E.C.1. Telephone: HEADquarters 1234. Remittances should be made payable to "*The P.O.E.E. Journal*" and should be crossed "& Co."

### Binding Cases

Cases for binding are available, and may be obtained from the Local Agents for 2s. Subscribers can have their copies of Volumes bound, at a cost of 7s. 6d., by sending the complete set of parts to the Local Agents or to the *P.O.E.E. Journal*, Engineer-in-Chief's Office, Alder House, Aldersgate Street, London, E.C.1. Orders for binding for Vols. 1-19 should indicate whether the original binding case with black lettering, or the later pattern with gold, is required. Cases with gold lettering are the only type stocked from Vol. 20 onwards.

### Back Numbers

The price of the JOURNAL, which is published quarterly, is 1s. 6d. (1s. 9d. post free) per copy, or 7s. per annum post free. Back numbers can be supplied, subject to availability of stocks, at 1s. 6d. each (1s. 9d. post free). Orders for back numbers may be sent to the Local Agents or to the Publishers.

### Advertisements

All communications relating to space reservations should be addressed to the Advertisement Editor, *P.O.E.E. Journal*, Alder House, Aldersgate Street, London, E.C.1. Communications regarding advertisement copy, proofs, etc., should be addressed to the Publishers, Messrs. Birch & Whittington (Prop. Dorling & Co. [Epsom], Ltd.), 49 Upper High Street, Epsom, Surrey.

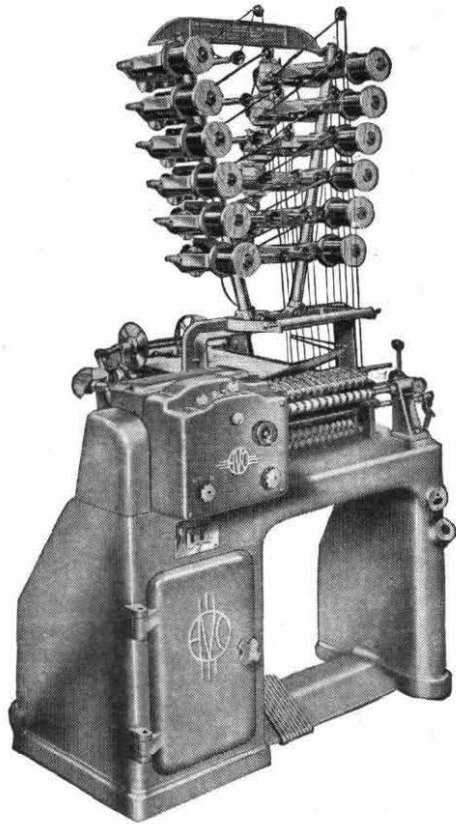

**DOUGLAS AND MACADIE**

*Automatic*  
**COIL WINDERS**

The large illustration depicts the improved "Douglas" Fully Automatic Multi-Winder, specially developed for the high-speed production of large quantities of coils with or without paper interleaving. It will produce round, square

or rectangular coils up to 6 in. each in length and up to 4½ in. diameter. As many as 12 smaller coils can be wound simultaneously within the total available winding length of 12 in. at headstock speeds of between 600 and 2,000 r.p.m.

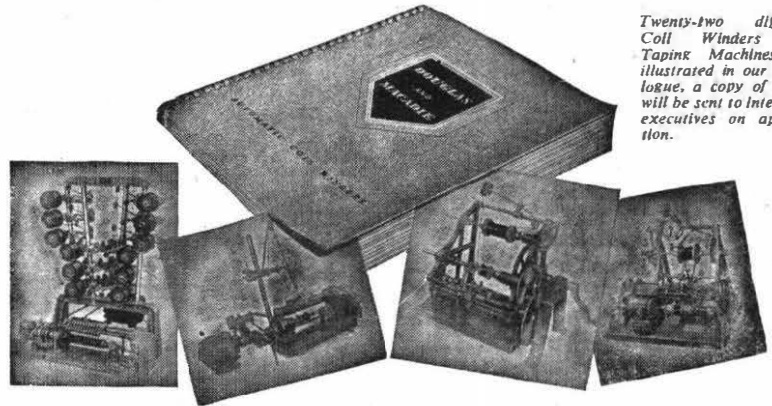

*Twenty-two different Coil Winders and Taping Machines are illustrated in our Catalogue, a copy of which will be sent to interested executives on application.*

Sole Proprietors and Manufacturers :

**The AUTOMATIC COIL WINDER & ELECTRICAL EQUIPMENT CO. LTD.**  
WINDER HOUSE • DOUGLAS STREET • LONDON • S.W.1 Telephone: VICTORIA 3404/9

C.2

*There's more  
in resistance work  
than meets the eye!*

Many have remarked on the fine appearance of Muirhead Decade Resistance Boxes — but we are even more concerned with what we put inside them. Take, for instance, the A-25 series; all resistors are wound on cards by methods that ensure very low time — constants. The internally mounted switches are protected from contamination and have low and constant contact resistance.

*Descriptive literature will be sent on request.*

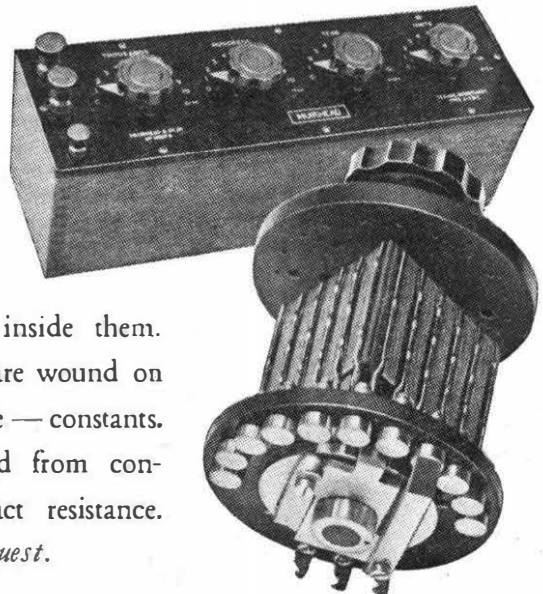

**MUIRHEAD**

Muirhead & Co. Limited, Elmers End, Beckenham, Kent. Tel. Beckenham 0041-2

FOR OVER 60 YEARS DESIGNERS & MAKERS OF PRECISION INSTRUMENTS

## *A Typical Example of* **H.T.A. DESIGN**

Stamp Booklet Vending machines to suit full size and half size booklets, for both indoor and outdoor application, are recent additions to the range of H.T.A. Products. These also include Telephone Coin Collectors, Stamp Selling Machines, Commodity Vending Machines, Ticket Printing and Issuing Machines, etc. etc.

### STAMP BOOKLET VENDING MACHINE.

The model illustrated is suitable for both Indoor and Outdoor use. A smaller machine is available for Indoor use in Post Offices, for Bookstalls and for Hotels to give this service to customers. Both machines can be supplied for either base or wall fixing. The capacity is 120 booklets 1 m.m. thick ranging in sizes from 25 m.m. x 47 m.m. to 50 m.m. x 70 m.m.

Enquiries should include size or samples of booklets in use and the coins required to operate the mechanism.

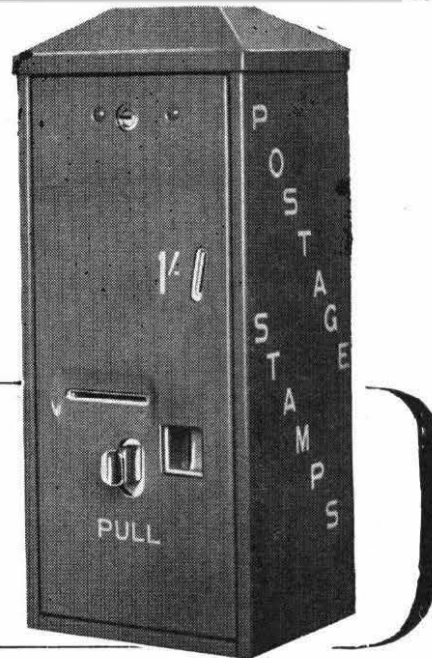

## **HALL TELEPHONE ACCESSORIES LTD**

*Precision Engineers & Instrument Makers*

DUDDEN HILL LANE • WILLESDEN • LONDON • N. W. 10

PHONE: WILLESDEN 9141

**TWENTY YEARS'  
SERVICE, and still  
giving its full output**

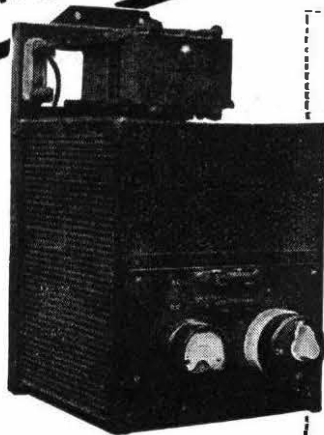

Here is ample proof of the reliability of Westinghouse Metal Rectifiers. This charger was installed in 1929 and has been working constantly ever since on a 110-volt supply.

The customers now require to use it on a 230-volt supply and the set

has been sent in for a transformer rewind. The opportunity of testing the rectifiers and the rest of the components was taken, when it was found that everything was up to standard and the set was still giving its full rated output.

## **WESTINGHOUSE RECTIFIERS**

*withstand the test of time*

**WESTINGHOUSE BRAKE & SIGNAL CO. LTD.**  
82 York Way, King's Cross, London, N.1

The resources of the

**G.E.C.**

**LONDON**

**BIRMINGHAM**

opened for  
daily service –  
17th December  
1949

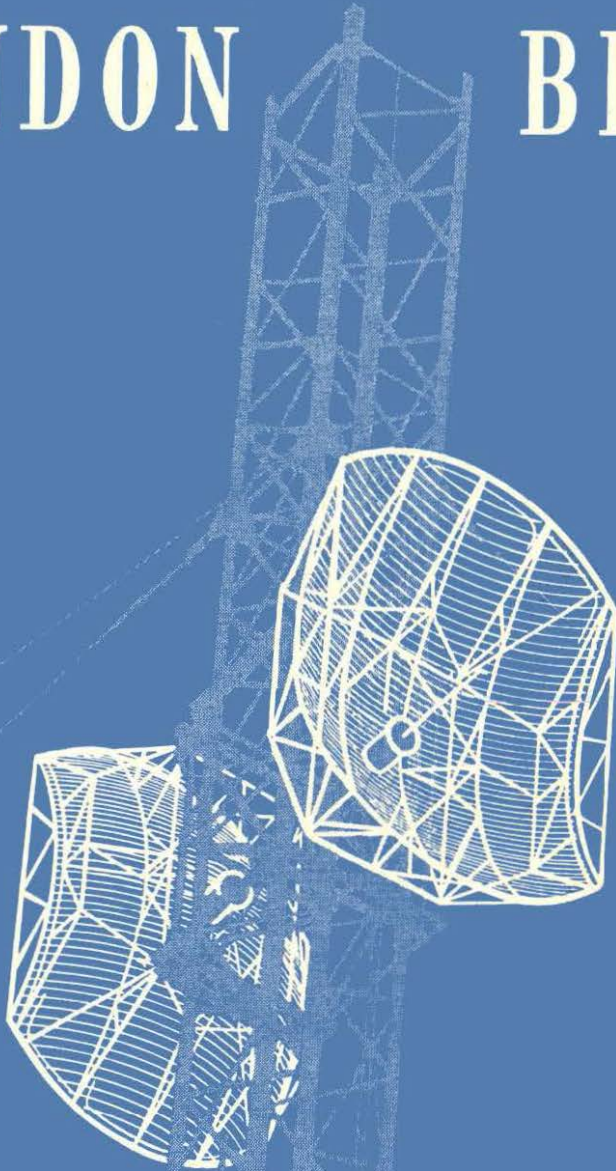

*Exterior of transmitter cabinets, showing alternative transmitter*

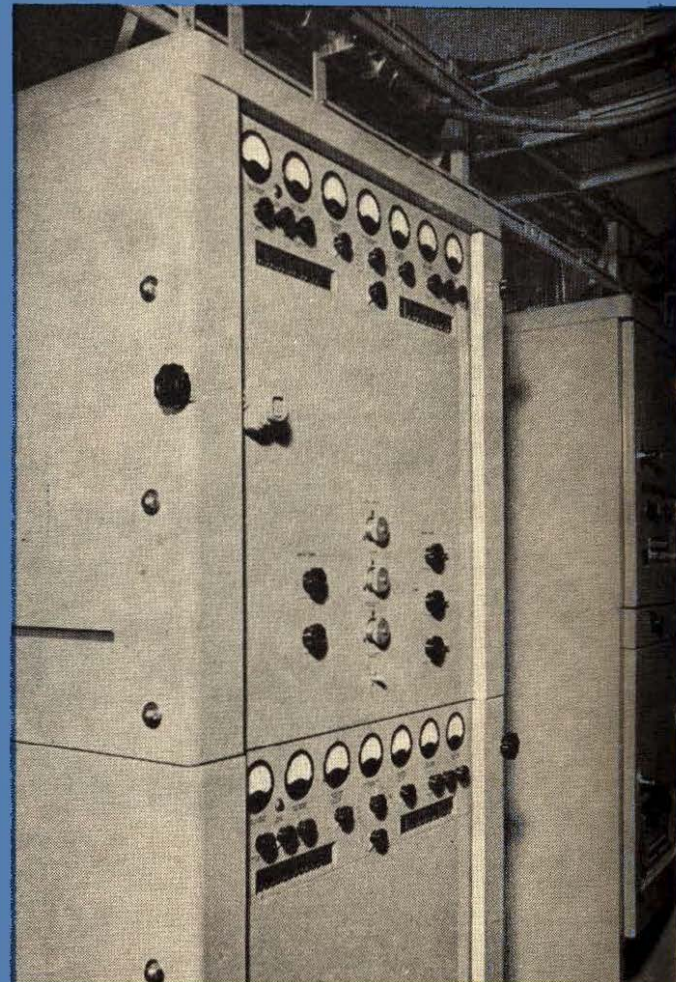

*The associated company, Pirelli-General Cable Works, designed the towers and the special feeder cables used within the equipment.*



were behind the development of the

# TELEVISION

# LINK

The resources of The General Electric Company were behind the design, production, installation, testing and servicing of the London-Birmingham television link. All that could be contrived for wideband U.H.F. transmission by knowledge, ingenuity and skill, in the Research Laboratories at Wembley and the Telephone Works at Coventry, went into the link. Now, after the link has been working for weeks of daily scheduled service, the G.E.C. has reaped the dividend in practical experience of its ideas on propagation, the processes of modulation, demodulation and frequency changing for a relayed U.H.F. system, automatic and almost instantaneous changeover to standby equipment, reversals of direction of transmission, and remote control from the terminals.

*Equipment for phase 2, to give simultaneous bothway transmission, is now in production.*

**For everything in telecommunications consult:—**

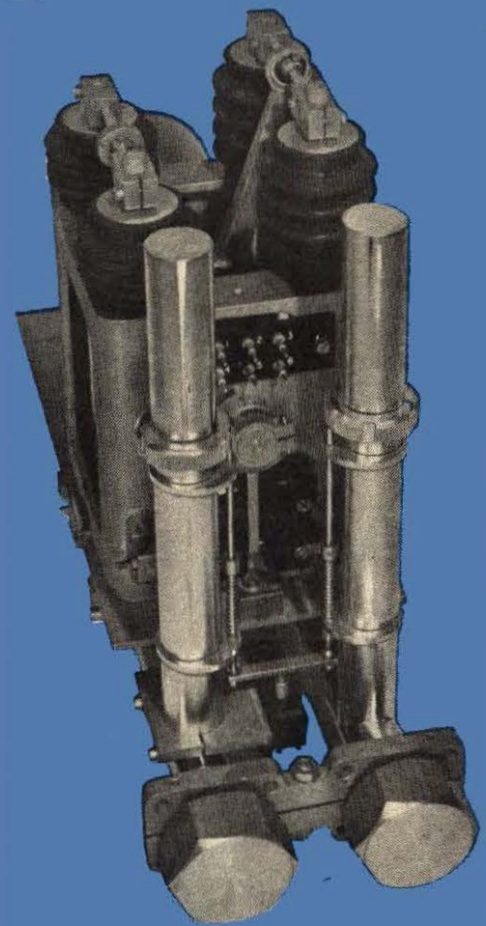

*A radio-frequency contactless aerial switch.*

## THE GENERAL ELECTRIC COMPANY LTD. OF ENGLAND

TELEPHONE, RADIO AND TELEVISION WORKS · COVENTRY · ENGLAND

Telephone : Coventry 4111 (10 lines)

Telegrams and Cables : "Springjack, Coventry"

The largest British electrical manufacturing organisation in the world

HEAD OFFICE · MAGNET HOUSE · KINGSWAY · LONDON · W. C. 2

Temple Bar B000 (90 lines)

"Electricity, Westcent, London"

Cables : "Polyphase, London"

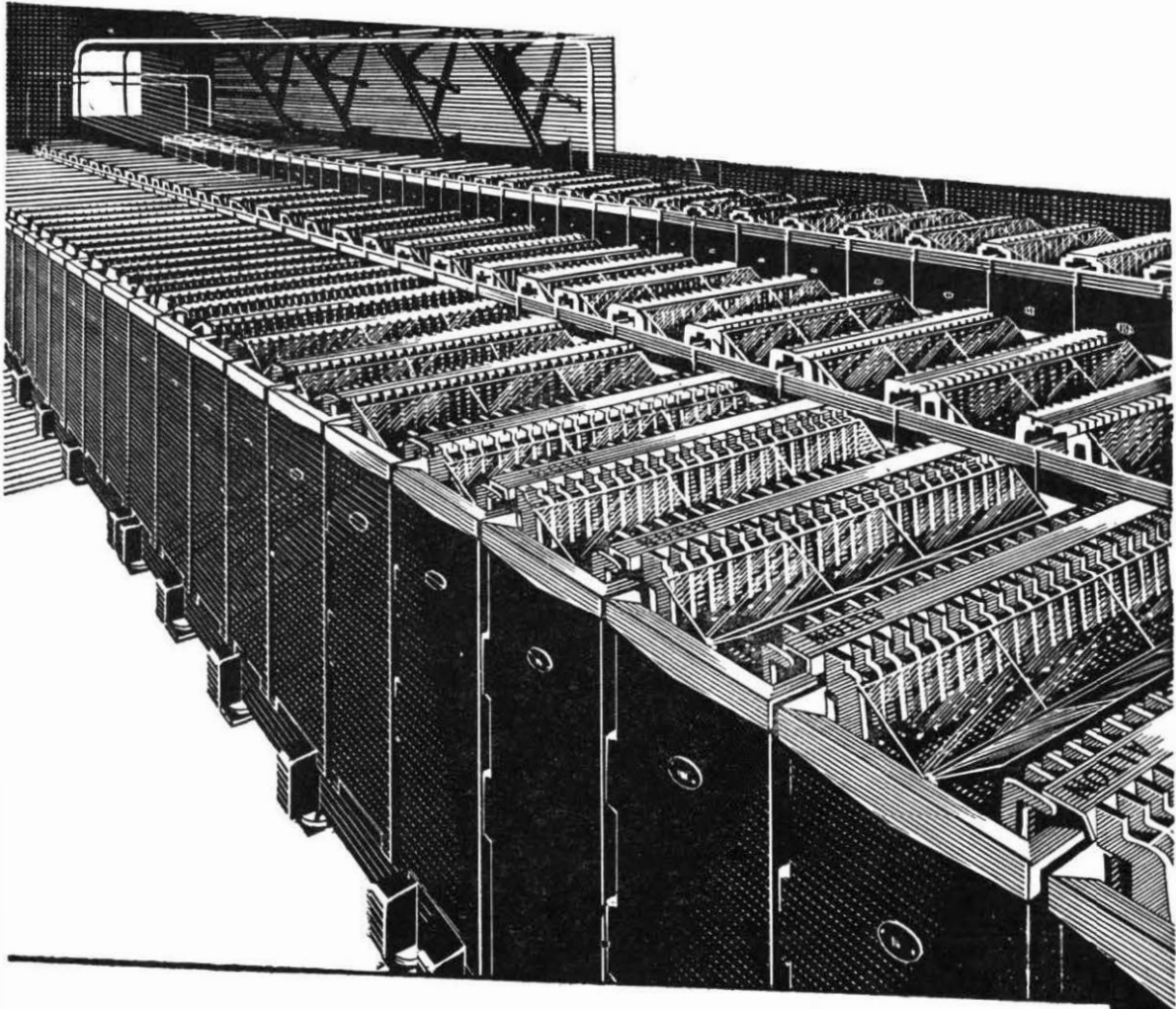

**A**lton Batteries of 10 to 15,000 ampere-hours are in service in sixty-five countries. The batteries now being shipped out all over the world will carry the name of Alton still further afield—Alton, shortest word in any language for good batteries and firm delivery dates.

\*

*Alton can also supply renewal plates for all makes of battery. British and Continental.*

# ALTON

**BATTERIES OF MERIT**

THE ALTON BATTERY COMPANY LIMITED, Alton, Hampshire Telephone: Alton 2267 and 2268 Telegrams: Battery, Alton

# V.H.F. PUSH BUTTON ATTENUATOR



## True V.H.F. loss measurement at last!

An outstanding development which in the first year of production has fully established itself with leading British communication organisations and remains the first and only accurate instrument of its kind.

## Two models available

Type 74600 - A : 0-9 db in 1 db steps

Type 74600 - B : 0-90 db in 10 db steps

Both have a 75-ohm characteristic impedance and will handle inputs up to 0.25 watts.

## 50 Mc/s Performance \*

MODEL	VARIATION BETWEEN 50 Mc/s and D.C.	ACCURACY OF D.C. ADJUSTMENT
0-9 db	$\leq \pm 0.01$ db per step	$\pm 0.05$ db at all settings
0-90 db	$\leq \pm 0.1$ db per step	$\pm 0.03$ db per step

\* Insertion loss relative to zero setting

## Ready for building into your own equipment

Calibration charts for frequencies up to 100 Mc/s for the 0-9 db model or 60 Mc/s for the 0-90 db model can be supplied on request.

## Standard Telephones and Cables Limited

Registered Office: Connaught House, Aldwych, London, W.C.2

TRANSMISSION DIVISION, NORTH WOOLWICH, LONDON, E.16

**Eclipse PERMANENT MAGNETS**

IN  
**TUNGSTEN · CHROME  
COBALT · ALNI · ALNICO  
& ALCOMAX**

Our Technical Development Section will be pleased to advise on any problem connected with applied magnetism.

Made by the manufacturers of  
"ECLIPSE"  
PERMANENT MAGNET CHUCKS

EM 7

**JAMES NEILL & CO. (Sheffield) LTD., SHEFFIELD, ENGLAND**

## VALUABLE FREE BOOK

Tells You How to Pass Your C. & G. or Promotion Exam. at First Attempt!



All Post Office Engineering personnel who are anxious to obtain early promotion should at once send for a copy of our handbook "ENGINEERING OPPORTUNITIES," which, among other intensely interesting matter, describes our unique methods of preparation for **TECHNICAL APPOINTMENTS IN THE POST OFFICE** (Assistant Engineer—New Style and Assistant Traffic Superintendent), **A.M.I.E.E., CITY AND GUILDS EXAMINATIONS** in Principles of Telecommunications (1-5), Radio (1-4), Telephone Exchange Systems (1-3), Telegraphy (1 and 2), Line Transmission (1 and 2), Lines Plant Practice (1 and 2), Mathematics for Telecommunications (1-5), Electrical Engineering Practice (Prelim. Inter. and Final), and outlines a wide range of non-examination courses in all branches of Electrical, Mechanical, Civil, Automobile, Aeronautical and Radio Engineering.

Assistant Engineer and Assistant Traffic Superintendent. Open competitions now resumed. Age extensions for established Civil Servants. Ask us for full details

We definitely guarantee  
"NO PASS—NO FEE"

If you intend to make the most of to-day's opportunities, you cannot afford to miss reading "ENGINEERING OPPORTUNITIES." It tells you everything you want to know to secure advancement, and describes many opportunities you may now be missing through lack of information. Send for your copy to-day—FREE and without obligation.

**BRITISH INSTITUTE  
OF ENGINEERING TECHNOLOGY**  
369 SHAKESPEARE HOUSE,  
17-19 STRATFORD PLACE, LONDON, W.1

# BIET



# Automatic

## TELEPHONE EXCHANGES

### NO. 16 SYSTEM

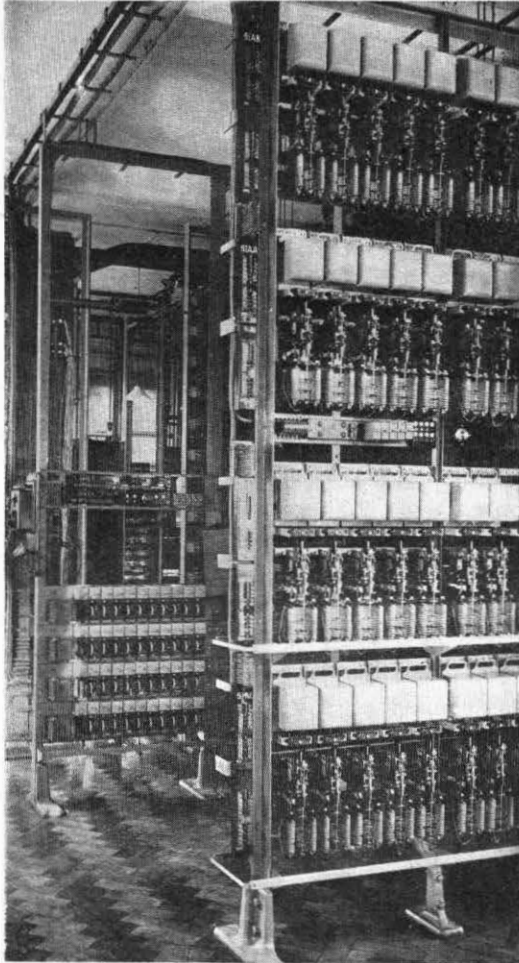

Automatic hooks Preston Exchange,  
Brighton (1927)

### NO. 17 SYSTEM

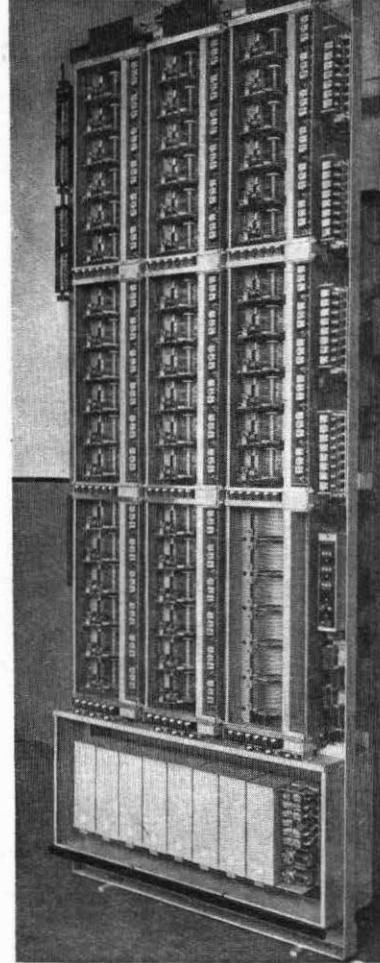

Rock of First Selectors  
with Covers removed (1950)

**PRESTON (BRIGHTON) T.E.**  
 Preston automatic exchange (Siemens 16, installed in 1927) is a satellite on Brighton with 5,200 working lines. Over the past year, the reported exchange faults have averaged about 0.04 faults per telephone per annum. During each of the weeks ending 2nd and 23rd September, 1949, the exchange excelled itself and the number of reported exchange faults was nil. Is this a record?  
 D. C. B.

Extract from Post Office Electrical Engineers' Journal, Jan. 1950 p.237

As in 1927, reliability is still a primary aim, and achievement, of our switching systems

# CARPENTER Polarized RELAY TYPE 4

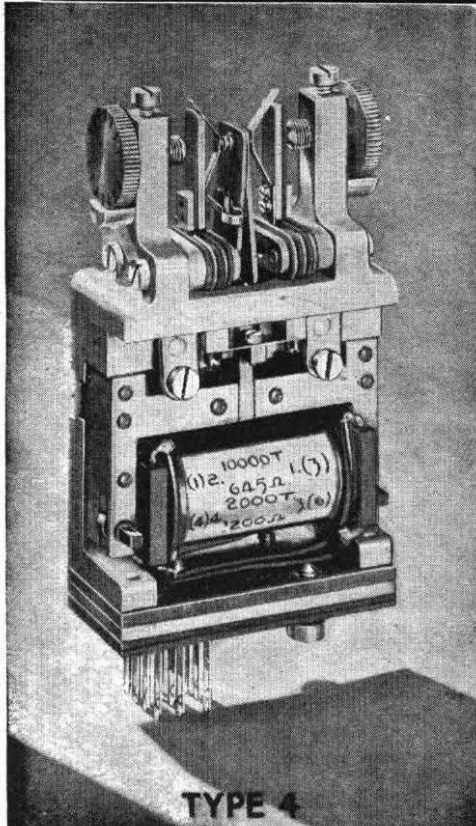

This is a medium speed, sensitive relay with long contact travel designed primarily as a telephone impulsing relay (D.C. dialling up to 100 miles and V.F. dialling on trunk circuits). It has also been successfully adopted for use in Telex systems.

Its sensitivity is such that when the gap is adjusted to .004 in. the relay will just operate at 50 cycles with 4 ampere-turns (corresponding to approximately 1 mVA) or on  $2\frac{1}{2}$  D.C. ampere-turns at low speeds. In service, however, the relay is normally operated at currents substantially larger than the minimum operating current.

Contact chatter is absent if the contact gap does not exceed .004 in. The contact gap is adjustable by means of fine pitch screws with knurled heads marked with .001 in. divisions.

Contacts on the armature tongue are insulated from it and thereby from the frame.

Terminals for soldered connections are fitted as standard.

The relay is supplied with a magnetic screening cover with transparent removable top to facilitate contact adjustment.

Dimensionally the relay is interchangeable with the type "3000" relay and can be supplied to fit directly to the drilling normally provided for the "3000" relay.

**Dimensions of the Type 4 Carpenter Relay are:— (With cover. Excluding wiring tags)**  
 $3\frac{7}{8}$  ins. high  $\times$   $2\frac{7}{8}$  ins. wide  $\times$  1 in. deep. Weight: 13 ozs.

Complete details available on request.

Manufactured by the Sole Licensees:—

## TELEPHONE MANUFACTURING CO. LTD.

Contractors to the British Commonwealth and Foreign Governments

HOLLINGSWORTH WORKS DULWICH LONDON, S.E.21

Telephone: GIPsy Hill 2211 (10 lines)

## HIGH GRADE DECADE ATTENUATORS

0.1% GRADE  
T or H NETWORKS

RANGE 0.1 to 110 db.  
0.01 to 10 nepers

TEMP. COEFF.  
0.0025% C

NO ERRORS UP TO FREQUENCIES OF  
100 Kc/s AND EXTREMELY USEFUL FOR  
FREQUENCIES UP TO 0.5 OR 1 Mc/s

ASSEMBLED INTO A DECADE SERIES  
OR AS PANEL MOULDED UNITS

ALSO SUPPLIED IN PORTABLE  
CARRYING CASES, COMPLYING WITH  
LINE TESTING REQUIREMENTS OF THE  
BRITISH POST OFFICE

## H. W. SULLIVAN

— LIMITED —

LONDON, S.E.15

Telephone: New Cross 3255 (P.B.X.)

## Electrical Standards for Research and Industry Testing and Measuring Apparatus for Communication Engineering

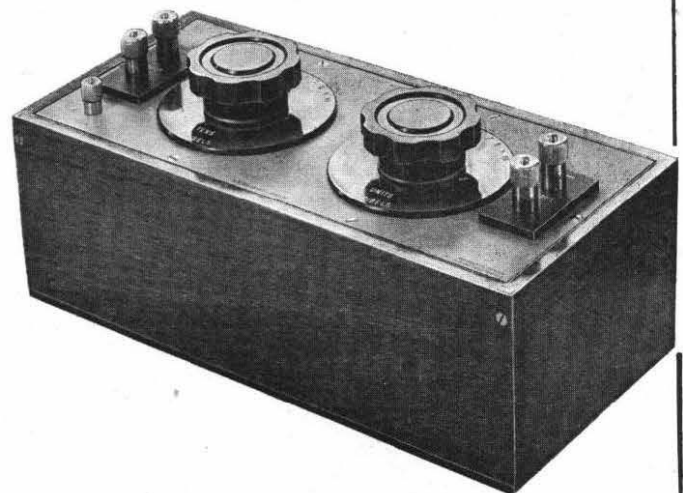

A SERIES OF METAL CASED HIGH FREQUENCY  
UNITS ARRANGED IN DEGREES OF ATTENUATION  
IN ASSOCIATION WITH SPECIALLY DESIGNED  
SWITCHES HAVING FINELY LAMINATED BRUSHES

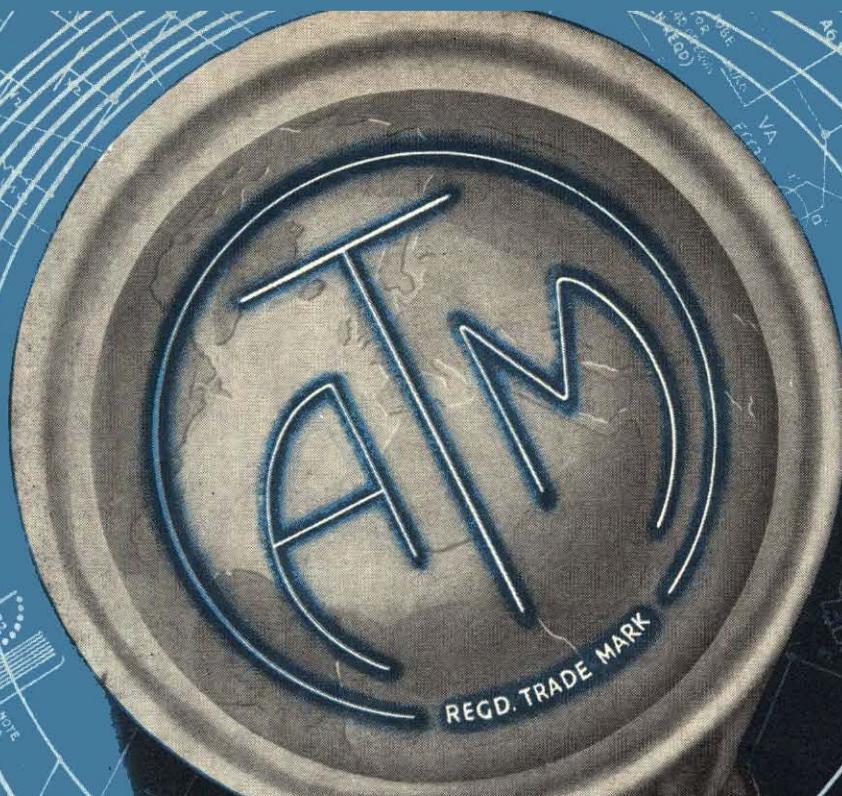

# TRACES THE PATTERN OF WORLD TELECOMMUNICATIONS



**T**HE pattern of world telecommunications is varied and complex. Varied because every problem requires an individual approach, involves a new assessment of available knowledge and a fresh consideration of existing methods of solution; complex because of all branches of engineering it is by far the most abstruse, involving in its approach to world communication problems the profoundest researches into physics and the development of special higher mathematical formulæ. This is the scientific background of the vast A.T.M. organisation which has at its disposal the specialised knowledge of over 50 years' experience in the telecommunication art and which has been responsible for many of the major inventions and discoveries in the subject during this period.

The scope of telecommunications is so vast that it requires the Company to employ the services of a large number of specialists in many subjects including acoustics, thermionics, electronics, piezo-electric and photo-electric phenomena, transmission theory, power engineering and measurement; it follows that such a body of collective knowledge is instantly available to deal with any problem for which the application of one or more of these techniques can provide a solution.



The scientific background of the Company is allied to an efficient organisation producing the following:—

### TELEPHONE EXCHANGES FOR NETWORKS OF ANY SIZE

- Director Exchanges for metropolitan and large provincial areas. Non-director main and satellite exchanges
- Automatic and automanual trunk exchanges
- Manual exchanges
- Private automatic exchanges (P.A.X.)
- Private automatic and manual branch exchanges (P.A.B.X. and P.M.B.X.)
- Calling line identification equipment
- Press Button telephone systems from 5 to 15 lines with or without loudspeaker master stations

### TRANSMISSION EQUIPMENT

- Single, three, twelve and twenty-four-channel carrier telephone systems for overhead lines or underground cables. Six, twelve, eighteen and twenty-four-channel carrier telegraph systems
- Loading coils
- Quartz crystals
- Carrier and audio repeaters
- Transmission testing apparatus

### SIGNALLING EQUIPMENT

- V.F. Systems of signalling and dialling using C.C.I.F. codes
- 500/20 c/s signalling equipment
- Long-distance D.C. impulsing systems
- 50 c/s dialling equipment

### REMOTE CONTROL SYSTEMS

- Systems of remote control with indication and telemetering equipment for the following services:
  - Electricity distribution networks
  - Electric railways; tram and trolleybus transport undertakings
  - Gas distribution networks
  - Water distribution networks
  - Oil distribution networks
- "Rythmatic" ripple control systems for street lighting, selective load control and other operations

### LIGHT CURRENT SIGNALLING SYSTEMS

- Mine telephones and signalling equipment
- "Electro-matic" vehicle-actuated traffic signals for simple and complex intersections. Interlinked systems

### ELECTRONIC DEVICES

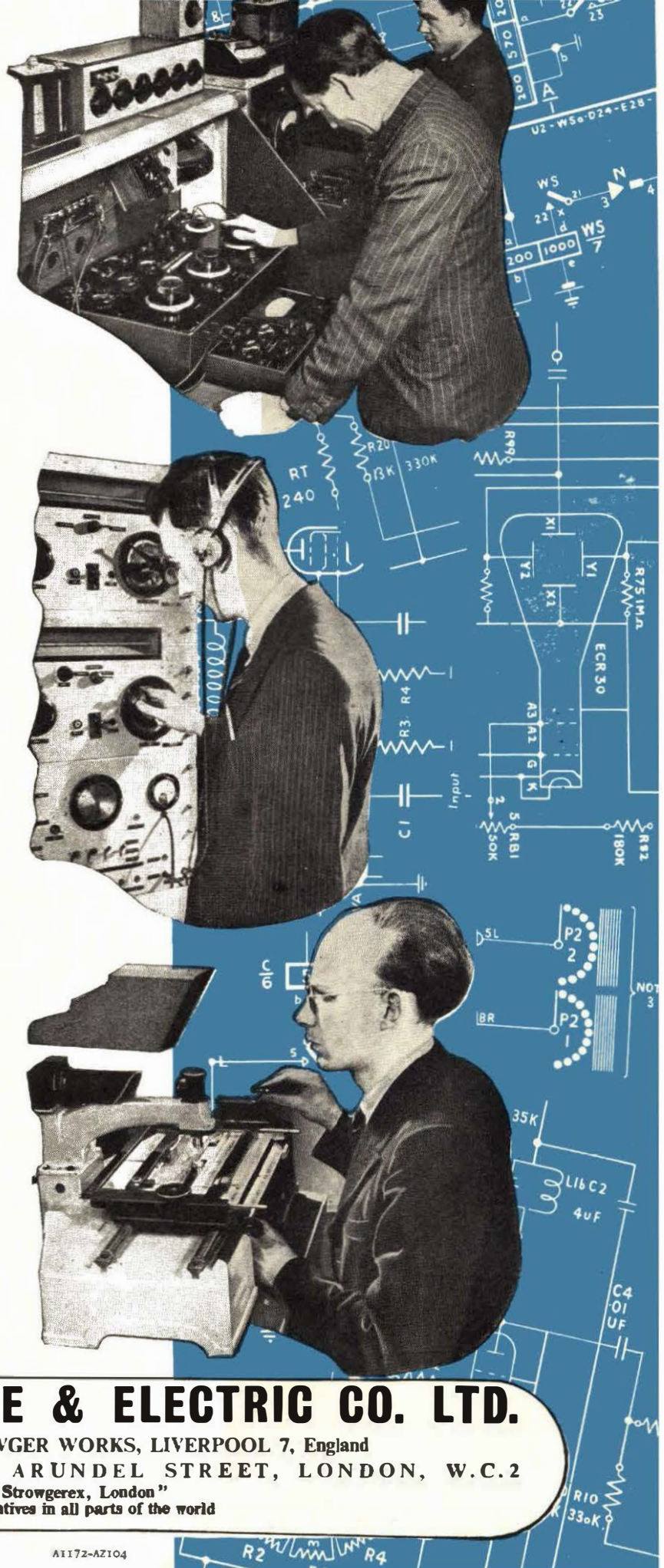

# AUTOMATIC TELEPHONE & ELECTRIC CO. LTD.

Registered Office and Works: STROWGER WORKS, LIVERPOOL 7, England

Export Department: STROWGER HOUSE, ARUNDEL STREET, LONDON, W.C.2

Cablegrams: "Strowgerex, London"

Agents and Representatives in all parts of the world

**Creed**

**TELEPRINTERS**

*Built by specialists  
in machine telegraphy~*



**N° 47 TAPE MODEL**

*Write for  
Bulletin N° 21*

**Creed & Company Limited**

**TELEGRAPH HOUSE  
CROYDON, ENGLAND**





# Our business... Communications

## *Standard* COMMUNICATION & CONTROL SYSTEMS

- Telephone
- Telegraph
- Teleprinter
- Radio Broadcasting
- Radio Communication
- Radio Navigation
- Sound Amplification
- Remote Control
- Remote Indication
- Telemetry
- Railway Signalling
- Railway Control
- Airfield Lighting Control
- Street Lighting Control
- Fire Alarm
- Totalisator
- Public Indicator
- Signalling (Office and Factory)
- Power Cable
- Communication Cable

## *Standard Telephones and Cables Limited*

TELECOMMUNICATION ENGINEERS

CONNAUGHT HOUSE, ALDWYCH, LONDON, W.C.2

Overseas Branch Offices: Cairo · Calcutta · Dublin · Johannesburg · Karachi · Salisbury



*.. and we  
repeat...*

**ERICSSON AUTOMATIC DIALS**  
are British Post Office Standard. Uniform pulsing.  
Impulsing contacts, gold, silver, platinum. Normal  
finish, black with black figures on white ground.  
Normal impulse ratios — 33% make, 66% Break.  
Can be supplied with neat dust cover with stainless  
steel finger plate and with sockets suitable for mounting  
in either the horizontal or vertical plane. Instruction labels  
and number plates can be arranged to suit customers' requirements.

**Ericsson**

**AUTOMATIC DIAL SWITCHES**

ERICSSON TELEPHONES LTD. Head Office: 22 LINCOLN'S INN FIELDS, LONDON, W.C.2 Tel: HOL 6936  
Works: BEESTON, NOTTS.

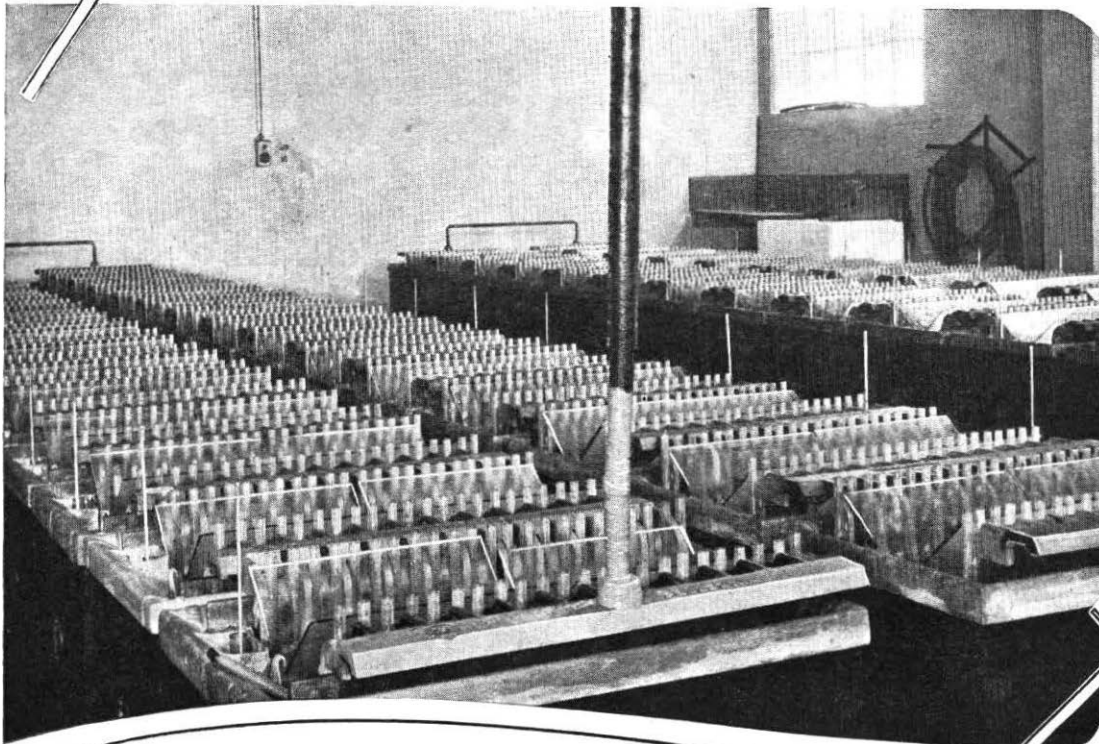

## POWER BEHIND THE LINES

**TUNGSTONE PLANTÉ CELLS** are being supplied to the British Post Office and Post and Telegraph Departments in many countries overseas. They conform fully to G.P.O. and British Standard specifications.

### OPEN TYPE CELLS

Similar to the illustration above, these are available in glass and/or lead lined wooden boxes in capacities from 100 a.h. to 500 a.h.

### REPLATALS

We are in a position to supply plates for the replating of any existing Planté Battery.

### ENCLOSED TYPE CELLS

As illustrated on the right, these are in moulded glass boxes with sealed-in lids. Capacity range from 10 a.h. to 200 a.h.

### HIGH VOLTAGE TELEPHONE BATTERIES

Portable Type. Standard layout for 50 volts, in waxed hard wood crates, exactly to the requirements of the G.P.O.

*Overseas customers are invited to cable or write their enquiries for batteries or parts. Visitors to London are welcome at our offices.*

# TUNGSTONE Batteries

For further particulars write : **TUNGSTONE PRODUCTS LIMITED**  
10 SALISBURY SQUARE · LONDON · E.C.4 · ENGLAND. Cables: "Dilutrum" London.



# How to keep the Night Watchman Awake!

Eversheds are sometimes called upon to supply recorders for strange purposes. Once a firm even purchased an Evershed Recorder to keep the night watchman awake! This particular individual had important duties to perform in processes left unattended during silent hours, and the recorder chart gave the management a precise picture of exactly how well the job was being done. As in many other industries a permanent record was wanted of information normally available for a fleeting second.

Industrial concerns, public undertakings, development engineers and research scientists alike pay tribute to the reliability of Evershed recorders, which can be used without supervision in unattended stations. Abnormal demands, unexpected fluctuations and excessive loads can all be studied, and suitable precautionary measures taken to prevent overloading and reduce unnecessary expenditure. In fact Evershed recorders give a visual picture of exactly what took place, and when it occurred.

*continued in next column*

## EVERSHED TEST THE WIRE!

Infinite care is taken with every detail in the manufacture of Evershed instruments.

Before wire is used, for example, it has to pass through a special 'wire-tester' designed in the Evershed laboratories.

Only then is it handed on to the production department.

## U.S. ADVISED 'USE MEGGER TESTERS'

*The American Associated Factory Mutual Fire Insurance Companies advocate annual check of earth resistances and say "the 'Megger' Earth Tester is easiest, quickest and most accurate method of doing this".*

### EVERSHED

PROCESS CONTROLLERS  
INDICATORS AND RECORDERS  
REMOTE CONTROLLERS  
MEGGER TESTERS

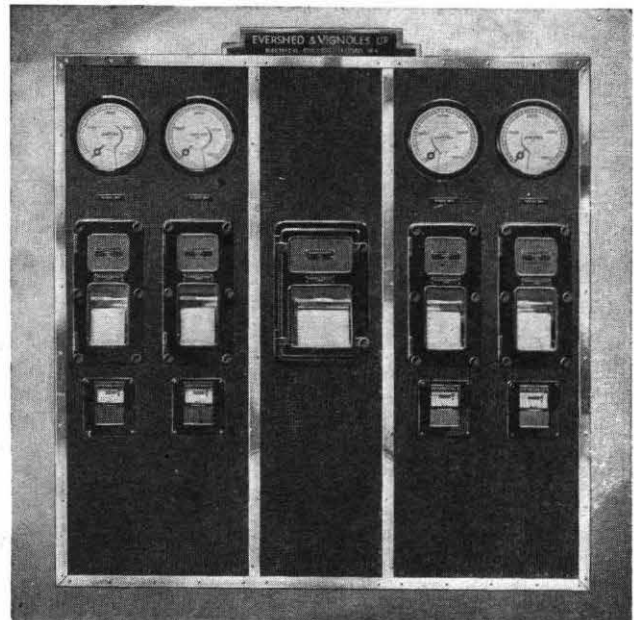

*Evershed Recorder Panel for distant indication and recording of electrical loads in a modern film studio.*

Here are a few of the many purposes for which Evershed recorders are now being used:—

*A cigarette manufacturer uses them to check the weight of packets as they come off production lines.*

*New Zealand railways keep a permanent record of shunting operations and thus study the most efficient methods.*

*The Post Office Engineering Department records the volume of telephone traffic.*

*The British Electricity Authority has Evershed recorders in power stations to record the outputs of generators, consumer demands, purity of boiler feed water and all kinds of valuable data. Portable models are used to obtain information on network conditions.*

*Water and sewage undertakings keep accurate records of the number of pumps in operation at any time.*

*Manufacturing concerns purchasing electrical power have installed Evershed maximum demand recorders for restricting peak loads and avoiding special tariff charges.*

*Railways and tramways carry out traction tests with Evershed recorders.*

And these are only a few applications. If you would like to know more about Evershed recorders, write today for

Publication . . . X 222

## EVERSHED AND VIGNOLES LIMITED

ACTON LANE WORKS · CHISWICK · LONDON · W4

Telephone: Chiswick 3670. Telegrams: Megger, Chisk, London  
Cables: Megger, London

# FERRANTI

## 7-Range CLIP-ON AMMETER



### RANGES

0 - 10 Amps.  
0 - 25 "  
0 - 50 "  
0 - 100 "  
0 - 250 "  
0 - 500 "  
0 - 1000 "



Thumb-operated  
switch

Fully insulated  
Accuracy within  
3% of full scale

Can be applied to  
bare or insulated  
conductors up to  
2½ ins. diameter

Weight...3lbs.

Delivery  
from Stock

FI 09

FERRANTI LTD., HOLLINWOOD, LANCS.

London Office : Kern House, Kingsway, W.C.2

## UNIVERSALLY ADOPTED

### G.N.T.Co. TRANSMITTER MODEL II2

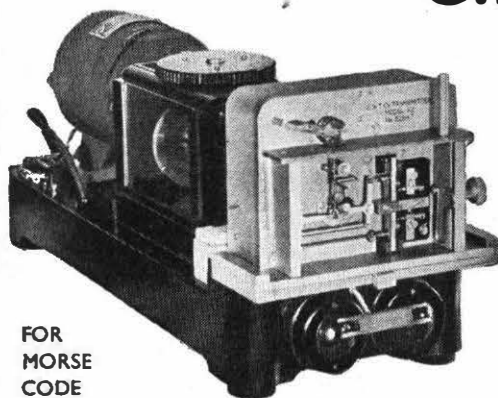

FOR  
MORSE  
CODE

13-250 words per minute without gear changes  
or readjustments.

Absolutely constant speed at all settings not-  
withstanding large voltage variations.

Noted for its easy maintenance.

Supplied with A.C. or D.C. motors as required.

**THE GREAT NORTHERN TELEGRAPH CO. LTD.**  
OF DENMARK

KONGENS NYTORV 28  
COPENHAGEN K. - DENMARK

AND

5, ST. HELEN'S PLACE,  
LONDON, E.C.3

**ELECTRICAL MEASURING  
INSTRUMENTS  
OF THE HIGHER GRADES**



**ERNEST TURNER ELECTRICAL INSTRUMENTS LTD.**

CHILTERN WORKS, TOTTERIDGE AVENUE, HIGH WYCOMBE, BUCKS.

Telephone : High Wycombe 1301/2

Telegrams : Gorgeous, High Wycombe

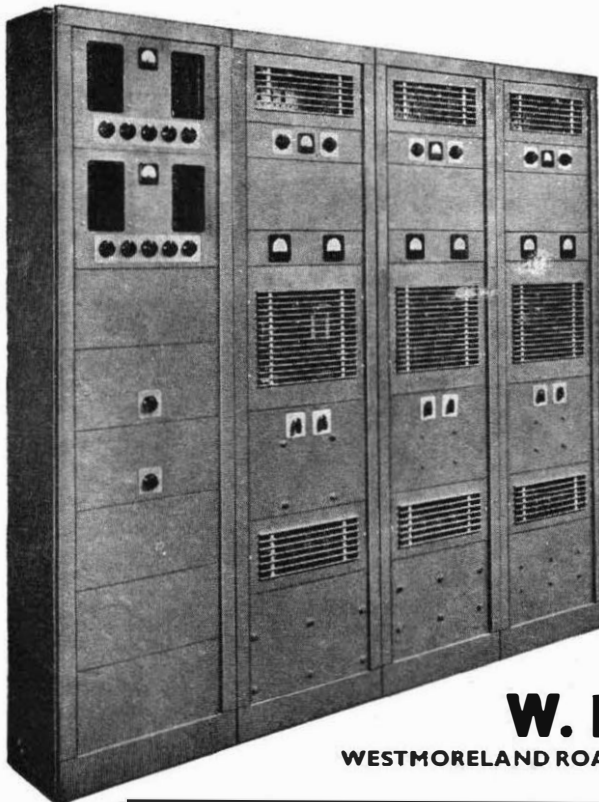

*The Mark II series of*  
**SAVAGE AMPLIFIERS**  
*for Broadcast Relay*

● These Amplifiers are examples of what careful design can achieve. A lift-off back panel affords immediate access for maintenance purposes and the removal of six screws releases the side covers of the rack and exposes all the interpanel wiring. Even when the rack is sandwiched between others the side covers can be moved just as easily. All valves are accessible from the front of the rack, and are protected by quick release grilles. The rack is completely flat fronted. The general appearance is further enhanced by the absence of a projecting front foot, and the masking of all panel fixing bolts. Similar racks carrying auxiliary apparatus can be placed side by side with amplifiers so that the whole installation is uniform in appearance. Complete specifications available on request.

**W. BRYAN SAVAGE LIMITED**

WESTMORELAND ROAD · LONDON N.W.9 · TELEPHONE: COLINDALE 7131

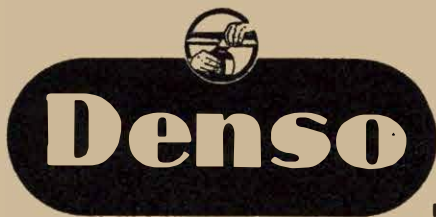

**has your Corrosion Problems**

**TAPED**



Denso Tape protects mains, services and all metalwork, below or above ground, against the menace of chemical and electrolytical corrosion. Ideal for water- and gas-proofing and an aid to frost-proofing. Emergency repairs to gas mains and services. Water-proofing temporary cable openings. Specifications and Price Lists of "Denso" Anti-corrosive and Sealing Products without obligation from :-

**WINN & COALES LTD.**

TERMINAL HOUSE, GROSVENOR GARDENS, LONDON, S.W.1  
Telephone: SLOane 6146/7. Telegrams: DENSELTE, SOWEST, LONDON

## Electronics in Industry

For twenty years our Engineers have been forerunners in the design and manufacture of resistances, anticipating and solving the many problems continually arising in the development of the use of electronics in industry.

That's why engineers today have every confidence in specifying BERCO resistances (fixed, sliding, rotary and wire wound): why they place their problems before us knowing that our years of experience in this branch of electrical products enable us to tackle any job satisfactorily.

May we offer our services to you!

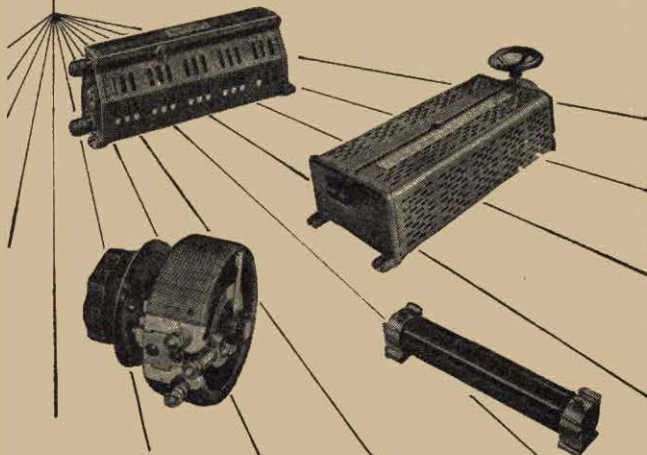

Write for leaflet No. BE102/2

**THE BRITISH ELECTRIC RESISTANCE CO. LTD.**  
Queensway - Ponders End - Middlesex  
Telephone: Howard 1492 Telegrams: Vitrohm Enfield



B.R.1021-A.Q.I

## SOUND INSTRUCTION by Postal Method

The I.C.S., largest school in the world devoted to spare-time training by the postal method, offers you highly specialised Courses for the following examinations:

- P.M.G. Certificates for Wireless Operators.**
- C. & G. Illumination Engineering (Inter.)**
- C. & G. Electrical Engineering Practice, Installation and Telecommunications.**
- Graduateship of the B.I.R.E.**

*I.C.S. Examination students are coached till successful.*

Other Courses meet the requirements of all who desire to qualify for responsible positions in Electric Power, Illumination, Heating and Traction Systems. Equally successful is our instruction for Telegraph and Radio Engineers, Radio Servicemen, and in Elementary Radar and Electronics, Advanced Short-Wave Radio and Television Technology.

Instruction is by correspondence from textbooks specially prepared by many experts.

*WRITE FOR OUR SPECIAL BOOKLET* and state the particular subject or Examination in which you are interested.

**YOU MAY USE THIS COUPON**

**International Correspondence Schools Ltd.**

Dept. 108, International Buildings, Kingsway, London, W.C.2

Please send me, free of charge, your special

booklet on.....

Name..... Age.....

(BLOCK LETTERS, PLEASE)

Address.....



## PITMAN'S for Technical Books



### Power System Interconnection

By H. Rissik. The Second Edition of this important work. Thoroughly up-to-date, it is invaluable to the practising electrical engineer and is a reliable textbook for the advanced student. 25/- net.

### Electric Cables

By Francis W. Main, M.I.E.E. A practical guide to the properties, construction, installation and maintenance of electric cables. The new edition contains up-to-date information on super-tension cables and other modern developments. With 52 illustrations. Third Edition. 12/6 net.

### Electrical Technology

By H. Cotton, M.B.E., D.Sc., M.I.E.E. A standard textbook and reference work for electrical engineers and students, now completely revised and with important new material. Sixth Edition. Illustrated. 18/- net.

**PITMAN, Parker Street, Kingsway, London, W.C.2**

# TELEPHONE CABLES

OUR BROCHURE No. 9E (1949),  
GIVING INFORMATION AND SPECI-  
FICATIONS FOR A WIDE RANGE  
OF TELECOMMUNICATION CABLES  
MANUFACTURED BY US, IS  
AVAILABLE UPON REQUEST.

TELEPHONE:  
SOUTHAMPTON  
2141 (5 lines).

## PIRELLI-GENERAL

CABLE WORKS, Ltd., SOUTHAMPTON.

TELEGRAMS  
"PIGEKAYBEL"  
SOUTHAMPTON



In public address and music relay to various points requiring different levels, the most satisfactory method is to pre-set speaker output on stud faders, either at the control panel or on individual speakers.

Agent in Denmark:  
Janko Kondensatorfabrik A/S,  
Holbergsgade 15, Copenhagen.

IN ANY CASE IT IS MOST DESIRABLE  
TO RELY ON

*Control by* **PAINTON**

PAINTON & CO · KINGSTHORPE · NORTHAMPTON

The advertisement features a central illustration of a control panel with a large knob and a speaker. To the left, a vertical list of room names is shown in boxes: BEDROOM, LOUNGE, FOYER, BALLROOM, TERRACE, and SWIMMING POOL. Lines connect these boxes to the control panel. The background is a dark grid pattern.