

# THE POST OFFICE ELECTRICAL ENGINEERS' JOURNAL

**VOL. 42**

**OCTOBER 1949**

**PART 3**

## CONTENTS

|  | PAGE                    |
|--|-------------------------|
| A SURVEY OF MODERN RADIO VALVES—Part 1—Introduction—<br>H. Staesby, M.I.E.E. . . . .   | 117                     |
| Part 2—The Physical Principles of Thermionic Valve Operation—<br>K. D. Bomford, M.Sc., A.M.I.E.E. . . . .  | 118                     |
| MUSIC CIRCUITS ON THE PHANTOMS OF 12- AND 24-CIRCUIT<br>CARRIER CABLES—H. J. Marchant, B.Sc., A.M.I.E.E., and<br>L. R. N. Mills . . . . .  | 124                     |
| HAMBURG-HANOVER COAXIAL CABLE SCHEME—J. Forrest ..   | 130                     |
| ORDNANCE SURVEY MAPS—F. Summers, M.I.E.E., A.M.I.I.A., and<br>L. Sloman .. . . .   | 133                     |
| CHANNEL ISLANDS COMMUNICATIONS—J. Rhodes, M.B.E.,<br>B.Sc.(Eng.), A.M.I.E.E. . . . .   | 141                     |
| THE WIRE ROPE TRACTION DRIVE—Part 2—Constructional Details<br>and Factors affecting Operation—R. S. Phillips, M.I.E.E. . . . .   | 144                     |
| PHONOGRAM AUTOMATIC DISTRIBUTION—Part 1—Field Trial<br>Installation and General Facilities—H. E. Wilcockson, A.M.I.E.E.,<br>and H. Walker . . . . .  | 149                     |
| SECTIONALISATION OF TELEPHONE REPAIRS—C. E. Lafosse<br>(Factories Department) . . . . .  | 154                     |
| NON-LINEAR INDUCTANCE AND CAPACITANCE AS MODU-<br>LATORS FOR AMPLITUDE-MODULATION SYSTEMS—<br>D. G. Tucker, D.Sc., A.M.I.E.E. . . . .  | 156                     |
| A TESTING AID FOR SUBSCRIBERS' APPARATUS FAULTSMEN<br>—L. A. Missen . . . . .  | 160                     |
| THE CONTRIBUTION OF THE JUNIOR SECTION OF THE<br>INSTITUTION OF POST OFFICE ELECTRICAL ENGINEERS<br>—H. R. Harbottle, O.B.E., B.Sc., D.F.H., M.I.E.E. (President,<br>Junior Section) . . . . . | 164                     |
| THE HIGH FREQUENCY BROADCASTING CONFERENCE,<br>MEXICO CITY, OCTOBER 1948—APRIL 1949 .. . . .   | 166                     |
| C.C.I.F. MEETINGS, MAY AND JULY, 1949 .. . . .   | 168                     |
| THE INSTITUTION OF POST OFFICE ELECTRICAL ENGINEERS  | 172                     |
| NOTES AND COMMENTS . . . . .   | 173                     |
| REGIONAL NOTES . . . . .   | 174                     |
| STAFF CHANGES . . . . .  | 178                     |
| BOOK REVIEWS . . . . .   | 129, 140, 148, 159, 165 |

Price 1/6 net

**THE INSTITUTION OF POST OFFICE ELECTRICAL ENGINEERS**

WITH THE NEW

G.E.C.

TRIGGER DIAL...

## THERE'S A PAUSE BEFORE

THE FIRST  
DIGIT...without a  
slipping cam**Articulated Trigger Action**

This fundamentally simple trigger type action in which a pivoted arm is actuated by the teeth of the impulse wheel, introduces a *completely reliable* method of obtaining a pause before the first digit.

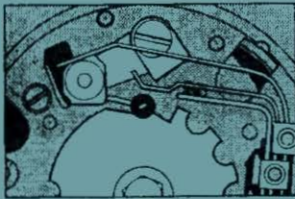

Fig. 1

Respective positions of the impulse springs, impulse wheel and trigger assembly whilst the dial is in the normal position.

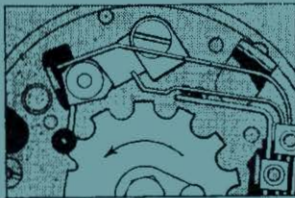

Fig. 2

During the forward motion of the finger plate, the impulse wheel rotates and transfers the trigger to the articulated position.



Fig. 3

When the finger plate is released, the impulse wheel, on the return motion, pick up the trigger and transfers it to the impulsing position. The time taken for the trigger to move from the articulated position to the impulsing position provides the pause before impulsing commences.

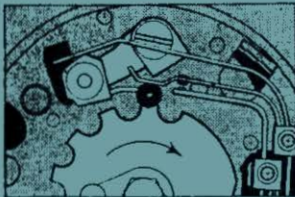
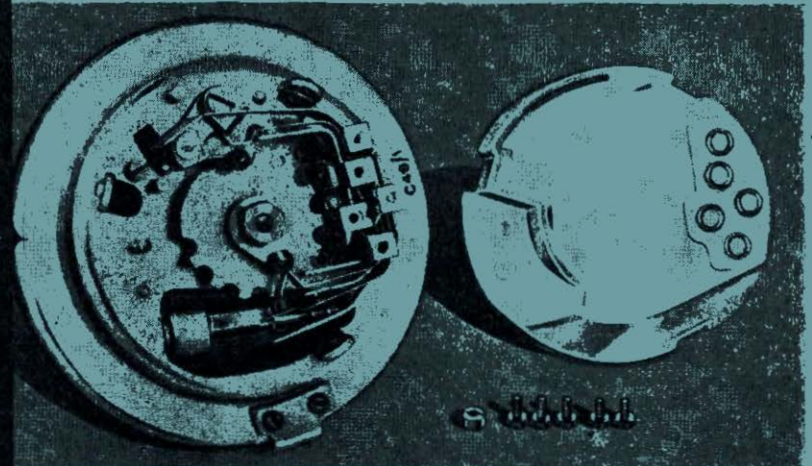

Fig. 4

The trigger rotating over the teeth of the impulse wheel operates the impulse springs, the impulse contacts being broken and re-made a number of times corresponding to the digit dialled.

**Outstanding features of this new dial are:**

- ARTICULATED TRIGGER ACTION.
- Pre-digit pause increased in length.
- Simplified finger stop
- More efficient governor mechanism.
- Still quieter action.
- Effect of wear on impulse ratio minimised.
- No clipped nor additional impulses.
- Improved dust exclusion.
- Sealed rear cover, if required.
- Long and trouble-free service under any climatic conditions.
- Completely interchangeable with B.P.O. standard.

Fitted with any of a wide choice of Number Rings and with Stainless Steel or Black Finger Plates. Supplied independently or in any of the G.E.C. Automatic Telephones.

For further information  
and for all details of  
the most up-to-date  
Telecommunication  
equipment consult:—

THE GENERAL ELECTRIC COMPANY LTD., OF ENGLAND

HEAD OFFICE: MAGNET HOUSE KINGSWAY  
LONDON, W.C.2

# THE POST OFFICE

## ELECTRICAL ENGINEERS' JOURNAL

Vol. 42

October, 1949

Part 3

### A Survey of Modern Radio Valves

Edited and introduced by  
H. STANESBY, M.I.E.E.

#### Part I.—Introduction

U.D.C. 621.385

**So many different types of valve now exist that most telecommunications engineers have difficulty in keeping their knowledge of them up to date, and this series of articles is intended to help them to do so. It outlines certain basic principles common to most valves and then proceeds to discuss the valves that have been developed for use in various frequency bands up to 30,000 Mc/s.**

IT is sometimes said that really important inventions need as much as fifty years before they reach maturity and that later improvements are in matters of detail. In 1904, J. A. Fleming, later Sir Ambrose Fleming, invented the thermionic valve. The first half-century of its existence will therefore have ended in another five years' time. Is it at all likely that by then its development will be more or less complete?

In the first ten years of its life the thermionic valve was used almost exclusively, and rather half-heartedly, as a diode for detecting radio signals, the form in which Fleming invented it. During that period, however, the grid was introduced by de Forest, a development more important perhaps than all that have followed it, because it turned the valve into a device for generating and amplifying oscillations. In the second ten years, the valve came into considerable use, but almost exclusively in the form of diodes and triodes for radio transmission and reception, and in repeaters for amplifying speech signals in audio frequency trunk cables. But little occurred in the development of fundamentally new types of valve. If we compare the progress of the first 20 years with that of the last ten, which have seen the birth of the cavity magnetron, the reflection klystron and the travelling wave tube, to mention only three of the valves invented in this country alone, and have seen valves introduced to such applications as the fusing of shells and the cooking of meals, it is clear that the tempo of development, far from slackening, is speeding up.

Perhaps the reason why the history of thermionic valve development has not traced the same general pattern that most other important inventions have, is that the valve should not be regarded as a particular invention at all, but as a principle that bears much the same relationship to light electrical engineering as, say, heat engines do to mechanical engineering; a principle that can be evolved and used in endless different ways.

Because the rate of development has been so high in recent years, and during the war the developments themselves were hidden from most of us, it has been

difficult, even for engineers associated with telecommunications since pre-war days, to keep informed about the various types of valve that have been developed. And if it is difficult for those who were more or less up to date in 1939, how much more difficult it must be for the new-comer, meeting for the first time such a range of valves that depend on so many different principles and are used in so many different ways.

A series of articles has therefore been written in an attempt to outline in fairly non-technical language the present state of valve development; an attempt that cannot be wholly successful, if only because any survey of developments for the highest frequencies will be out of date before it is published.

Following these introductory remarks is an article on certain principles and phenomena that affect all valves to a greater or lesser degree. This, it is hoped, will avoid the two dangers of taking for granted material that may not be familiar to some readers, and of covering the same ground in several places. The third and fourth articles, respectively, will consider receiving and transmitting valves for use on frequencies below about 30 Mc/s. No doubt older readers will find there much that is familiar to them, particularly on receiving valves, but there have been recent developments, particularly in miniature valves that should interest them. The remaining two articles will describe valves developed, many of them during the war, for use in Bands 8, 9 and 10\* (frequencies ranging from 30 to 30,000 Mc/s).

It may be useful for the reader to bear in mind that the order followed in this series is roughly the same as the time order in the history of the valve. This is not surprising, because for the last 30 years or so the trend in radio and line communication has been towards the use of higher and higher frequencies. The parallel with the history of valve development is useful because as the reader passes from article to article he will see that the time taken for electrons to cross the interelectrode space in a valve was of little importance originally. It was not until the later

\* P.O.E.E.J., Vol. 42, p. 47 et seq.

1920's, when frequencies above a few megacycles per second began to be employed, that the effect of transit time came to be at all noticeable. Rather later, when frequencies of the order of 100 Mc/s came to be studied, transit time, and the reactances introduced by the valves and their holders, were found to limit the highest frequencies at which existing valves could be used. This led to the development of valves with very small electrode spacings to reduce transit time, and short thick leads to reduce capacitance and inductance; but it seemed that a point must soon be reached where the inertia of the electron prevented any upward extension of the frequencies used.

Roughly speaking, this point corresponds to the end of the fifth article in the series.

The impasse was overcome by what virtually amounted to a revolution in technique: the very factor that was impeding progress, electron transit time arising out of the inertia of electrons, became

an essential factor in an entirely new series of valves. Valves were developed whose mode of operation did not depend on accelerating electrons so quickly from a position of rest near the cathode that they could reach another electrode in a fraction of a cycle of the signal frequency. They depended instead on cyclically varying the velocity of electrons already in rapid motion, and relying on their time of transit to electrodes further along their path to change the smooth flow of electrons into one in which they were clustered in bunches. To go further would be to anticipate the last article in the series. It is sufficient to indicate that those factors that appeared to bar the way have been turned so much to advantage that frequencies upwards of ten times those previously employed are now being exploited.

We have not yet answered the question that was posed at the beginning of this introduction. The reply is an emphatic "no."

## Part 2.—The Physical Principles of Thermionic Valve Operation

U.D.C. 621.385

K. D. BOMFORD, M.Sc., A.M.I.E.E.

A survey is made of various factors common to most thermionic valves. The phenomena of primary and secondary emission, space charge and transit time and the functions of various electrodes in the more conventional types of valve are discussed.

### Introduction

IN all its many forms the thermionic valve depends for its action on the passage of free electrons through an evacuated space, and the properties of various types of valve cannot very well be discussed without referring to a number of underlying principles and, if only briefly, to some of the more basic phenomena involved.

The first essential is to outline very roughly the structure of the atom and to give a picture of the way in which substances can be made to emit electrons.

### ELECTRON EMISSION

#### *Electrons and Ions.*

An atom of any particular substance consists of a relatively heavy nucleus and a definite number of electrons that may, for the purpose in view, be regarded as moving in planetary paths round the nucleus. The structure of the nucleus and the number of the electrons normally circulating round it depend upon the element that the atom represents. All the electrons have equal negative charges and the nucleus has a positive charge that is just sufficient to neutralise the negative charges of the normal quota of electrons; so that the complete atom is neutral.

In conductors, some of the moving electrons are so loosely tied to their paths that they are continually changing places with electrons in other atoms, and they can be made to drift in one direction by applying a voltage externally. This drift of electrons constitutes a flow of current through the material in the opposite direction to the movement of the electrons. The velocities of the loosely tied electrons can be increased to such a degree by raising the temperature that electrons break through the surface of the material into the surrounding space. This thermionic emission of electrons is the basis of the thermionic

valve, for once they are an appreciable distance outside the surface the electrons are readily attracted to an adjacent positively charged electrode, e.g. the anode; this produces a flow of current through the intervening space in a direction assumed by convention to be from the positive electrode to the emitting surface.

It may be of interest to note some of the magnitudes associated with an electron. It has a negative charge of approximately  $1.6 \times 10^{-19}$  coulomb and a mass when at rest of only  $9.1 \times 10^{-28}$  gram. It is the smallest known particle, with an apparent radius of about  $1.9 \times 10^{-13}$  cm. and behaves as if it is extremely dense, many thousands of millions of times denser than iron. By comparison, the nucleus is much heavier and largely determines the mass of the atom.

Those atoms that have lost one or more electrons are called ions and obviously have a positive charge equal in magnitude but opposite in sign to that of the missing electrons. Such ions are commonly formed in valves by collisions between electrons in transit and the residual atoms of gas in the inter-electrode space. These collisions detach electrons from the atoms and augment the electron flow but, what is more important, the much heavier positive ions are attracted to the emitting surface and their impact can damage the emitter if the bombardment becomes severe.

#### *Principles of Emission.*

The production of free electrons by raising the temperature of the emitting electrode until the electron velocity is sufficient to break through the surface, is called thermionic or primary emission. Free electrons are also produced by secondary emission when an electron or ion travelling with high velocity bombards an electrode with sufficient force to release electrons from atoms near the surface.

For the application under discussion, primary and secondary emission can only be effective in a relatively high vacuum, because the electrons would otherwise be blocked by collision with atoms of gas; incidentally most emitting substances would oxidise at the operating temperature if heated in air. In some instances, however, traces of gas are deliberately introduced to obtain a specific effect.

The restraining forces opposing primary emission at a surface are a complex combination of attraction and repulsion by adjacent electrons and ions, acting on those electrons that are continually jumping from atom to atom. These electrons can only break through the boundary forces when their velocity is raised beyond a certain value characteristic of the emitting material, and the work per unit charge that must be performed in forcing an electron through the surface is called the work function of the material. The work function is constant for a given material, and, although it is normally expressed in volts, i.e. the potential difference that would accelerate an electron to the requisite speed, the electrons in the cathode of normal valves in fact acquire the necessary velocities from the heat applied to the cathode. Clearly, the lower the work function the greater the emission for a given temperature. Once through the surface, the electron must overcome the force attracting it back to the emitting surface; this force, however, gets progressively weaker the further the electron travels and after only a short distance, it varies inversely as the square of the distance.

#### *Velocity of Emission.*

The electrons are emitted with varying velocities which follow a modified Maxwellian distribution, and when the electron stream is collected by the anode the statistical variation in the rate of arrival gives rise to small variations known as shot noise. This is important in that it places a lower limit to the magnitude of any signal that can be carried by the electron stream, without being overwhelmed by the noise.

#### *The Emission Equation.*

Thermionic emission is thus seen to be dependent upon the temperature and work function of the material, and is actually given by the following equation

$$I = AT^2 e^{-b/T} \quad \text{amps. per square cm.}$$

where

$T$  is the temperature in degrees Kelvin ( $273 + C^\circ$ ),

$A$  is a constant depending upon the material,

$b$  is  $11,600 \times$  (work function in volts),

and  $e$  is 2.718.

The exponential term makes the magnitude of the emission very sensitive to small changes in either the temperature or the work function. By differentiating with respect to temperature it is easily shown that the percentage increase in emission is  $(2 + b/T)$  times the percentage increase in temperature, that is over 40 times as great for the normal oxide-coated emitter. Similarly, the change in current for a small alteration in the work function is magnified  $b/T$  times or about 10 times for the oxide-coated cathode.

The values of the factors  $A$  and  $b$  are such that

there are relatively few materials capable of giving worthwhile emission at temperatures below their melting points, and these fall into three classes (1) pure metals; (2) atomic film emitters; and (3) oxide emitters, in ascending order of emission efficiency.

#### *Emission from Pure Metals.*

Tungsten, and to a lesser extent, tantalum are the only metals of practical importance and both have high work functions, 4.52 volts and 4.1 volts respectively, which are offset by their very high melting points enabling tungsten to be operated at  $3,500^\circ\text{K}$  and tantalum at  $3,100^\circ\text{K}$ . Tungsten has other advantages in that it is very stable and can withstand excessive positive ion bombardment much better than other types of emitter. It is therefore used widely in high-power valves using anode voltages exceeding 4,000 volts, where the velocity of arrival of positive ions at the filament is extremely high. Unfortunately, tungsten has the drawback of being difficult to process into filaments. Although tantalum is much easier to work it is more readily poisoned, i.e. its emissive properties are impaired by the presence of residual gas in the valve, and this is why tungsten is normally used in high-power transmitting valves.

#### *Atomic Film Emitters.*

The improvement in emission obtained by forming a thin surface layer of a particular metal on another metal was discovered by accident when thorium was added to tungsten to improve its mechanical properties. With suitable and somewhat intricate preparation a very thin film of thorium, approximately one atom thick, can be made to diffuse up to the surface of the tungsten, and in this state a working temperature very close to the melting point of thorium can be maintained without evaporating the film. In addition, the work function, 2.6 volts, is lower than that of either pure tungsten, 4.52 volts, or pure thorium, 3.4 volts. The combination of lower work function and relatively high working temperature increases the emission well above that of pure tungsten so that below 4,000 volts but above 1,000 volts on the anode the thoriated tungsten emitter is the best available, and it is competing successfully with pure tungsten at even higher voltages as vacuum technique improves and reduces the positive ion bombardment.

#### *Oxide-Coated Emitters.*

Oxide-coated emitters normally consist of a mixture of barium and strontium oxides on a suitable base metal and are so efficient that they are used to the exclusion of almost all other cathodes for valves in which the anode potential is less than 1,000 volts; above this, they are easily damaged by the bombardment of positive ions. The oxides are used in the form of a coating either on a directly heated filament or on an indirectly heated cathode. The latter arrangement has the advantages that A.C. power can be used for the heater wire and that the cathode is at a uniform potential, not necessarily tied to the heater supply. The filament type of cathode has a voltage

gradient due to the heating current, but the thermal efficiency is of course much greater.

Although it is believed that emission takes place from small particles of the free metal on the surface, the work function is lower than that of the unoxidised metal, being about 1.0 volt. This means that copious emission can be obtained at temperatures of about 1,100°K, at which temperature the oxides are quite stable in a vacuum. The oxides are not stable in air, however, even at room temperature, and must therefore be formed after the valve is evacuated. Usually a coating of carbonate or hydroxide is used; this is then activated by heating, usually assisted by deliberate positive ion bombardment, which at this stage can be tolerated.

The emission characteristics of the three alternative types of cathode are summarised in Table I and illustrate the marked advantage of the oxide coated electrode from an efficiency point of view.

The oxides are affected by residual gases in the valve, particularly by oxygen, which poison the material and restrict its life.

TABLE I  
EMISSION CHARACTERISTICS OF CATHODE MATERIALS.

| Material                   | Work function<br>Volts. | Maximum operating temperature<br>°K | Average emission efficiency.<br>mA per sq. cm. per watt. | Anode voltage range for which filament is used<br>Volts. |
|----------------------------|-------------------------|-------------------------------------|--|--|
| Tungsten                   | 4.52                    | 3,600                               | 5  | greater than 4,000                                       |
| Thoriated Tungsten         | 2.6                     | 1,900                               | 50   | 1,000-4,000*   |
| Barium and Strontium oxide | 1.0                     | 1,100                               | 500<br>(100 for indirectly heated cathode)               | less than 1,000  |

\* Thoriated tungsten may be used at higher voltages when special care is taken to improve the vacuum.

#### Peak Emission.

Oxide-coated emitters have the additional property of giving extremely high peak emissions, of the order of 100 amps. per square cm. for very short periods. The emission rapidly falls from its peak value, but after a short rest period for the formation of further pure metal particles the emission returns to normal and a succession of high energy pulses can therefore be obtained in this way.

#### Secondary Emission.

The magnitude of the secondary emission from the anode and from other electrodes subject to high positive potentials depends, of course, upon the number of bombarding electrons, their velocity of arrival, and upon the electrode material. The ratio of secondary electrons to bombarding electrons can be less or greater than unity and with caesium, for instance, the ratio may approach ten. Other materials yield lower ratios but all conductors and insulators yield secondary emission in some degree.

The metals commonly used in valve construction,

such as copper, nickel and molybdenum, all have a maximum ratio of about 1.4, as shown in the curves of Fig. 1. These curves<sup>1</sup> also show that the secondary

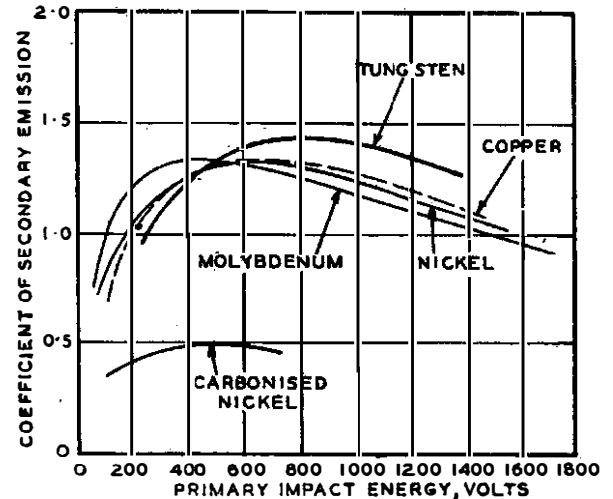

FIG. 1.—SECONDARY EMISSION CHARACTERISTICS SHOWING THE RATIO OF SECONDARY TO PRIMARY ELECTRONS AS A FUNCTION OF THE PRIMARY ELECTRON IMPACT VELOCITIES.

emission passes through a maximum as the voltage is increased, the highest emission normally occurring between 300 and 600 volts.

The condition of the surface has a marked effect on the secondary emission and unless special cleaning methods are employed the effect may be increased as much as five times by such slight contamination as materials may experience during commercial production, and the curves of Fig. 1 only apply to absolutely clean surfaces.

The addition of a carbon black coating reduces the emission and it is therefore common practice to carbonise anodes both for this purpose and to improve thermal radiation.

## THE DIODE

### Electron Movement in the Diode.

After the emission from the cathode the movement of electrons in a diode is governed by the normal laws of motion in a straight line, neglecting the interaction between adjacent electrons discussed in the next section. An electron is attracted to the positively charged anode with a force determined by the product of the voltage gradient and the electron charge. This accelerates the electron from a very low emission velocity at the cathode to a relatively high velocity at the anode. The arrival velocity is readily calculated and is given by:

$$v = 5.9 \times 10^7 \times \sqrt{V} \text{ cms. per sec.}^*$$

where  $V$  is the anode voltage. The emission velocity is assumed to be zero. Thus, an anode voltage of 100 volts will produce an electron arrival velocity of about 3,650 miles per sec., which, although high, still does not approach that of light.

<sup>1</sup> J. H. Owen Harries. "Secondary Electron Radiation" *Electronics*, Sept., 1944, p. 100.

\* This equation ceases to be valid when the velocity approaches that of light, i.e., for extremely high voltages.

The transit time of an electron from cathode to anode may be similarly calculated and is given by

$$t = \frac{3.4 \times S \times 10^{-8}}{\sqrt{V}} \text{ secs.}$$

where  $S$  is the distance from cathode to anode in cms. and  $V$  is the anode voltage.

Transit time begins to affect the performance of a valve slightly when it is of the order of 1 per cent. of the time of one cycle of the applied signal and Fig. 2

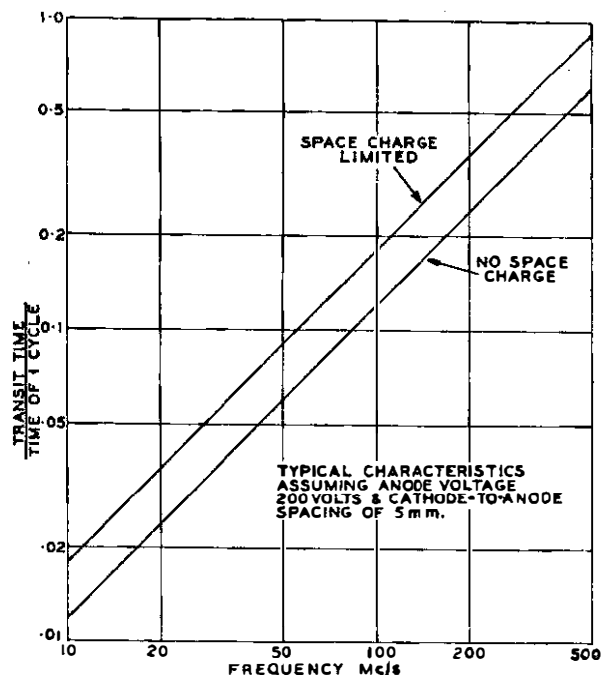

FIG. 2.—ELECTRON TRANSIT TIME/TIME OF ONE CYCLE AT VARIOUS FREQUENCIES FOR A TYPICAL HIGH PERFORMANCE PENTODE.

shows the ratio of transit time to the time of one cycle for various frequencies, taking typical values of  $V = 200$  volts and  $S = 0.2$  cms. As discussed in the next section, space charge, which is normally present under ordinary operating conditions, increases the transit time by 50 per cent. and results in the upper of the two curves of Fig. 2. In this case it will be seen

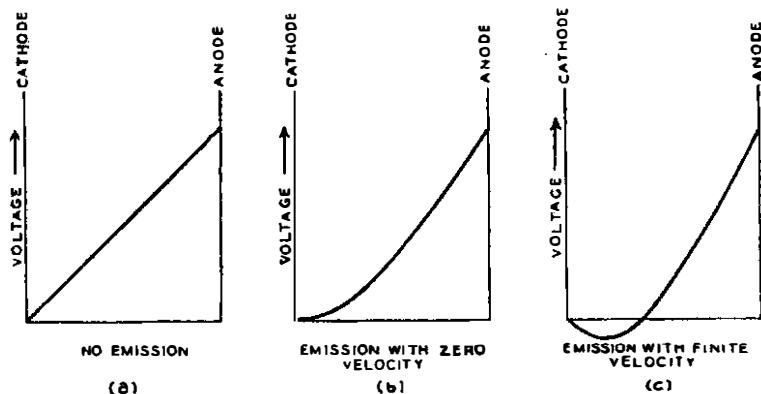

FIG. 3.—POTENTIAL GRADIENT IN THE DIODE VALVE: (a) WITHOUT SPACE CHARGE, (b) AND (c) SHOWING EFFECT OF SPACE CHARGE.

that the ratio of transit time to one period of the applied signal is 2 per cent. at about 12 Mc/s.

#### Space Charge Effects in the Diode.

Assuming a finite anode voltage but an unlimited cathode emission the anode current will be influenced by the presence of the electrons in the cathode-anode space, which constitute a distributed negative space charge modifying the potential distribution in such a way as to reduce the electron flow. The effect of the space charge can be conveniently visualised by considering the potential distribution of an idealised diode with flat parallel electrodes, in the following manner.

These curves of the potential distribution between cathode and anode are shown in Fig. 3: a straight line (a) when there is no emission from the cathode, a curved line (b) when emission is assumed to occur at zero velocity, and a second curved line (c) that dips below the horizontal axis when emission velocity is taken into account. In the case of (b) the presence of the negatively charged electrons depresses the voltage characteristic, but since the potentials of the electrodes are maintained unchanged the curve must assume the general shape shown. The slope of the curve must be zero at the cathode end. It cannot be negative because zero emission velocity is assumed and the emission itself would then cease, and if it were positive more electrons would be emitted until it became zero again. Thus, however great the emission capability of the cathode, the electron flow will limit itself to this equilibrium value.

In the practical case of finite emission velocities the voltage gradient will be negative adjacent to the cathode and will pass through a minimum, as shown in the curve of Fig. 3 (c), known as the potential barrier. Some electrons will not be emitted with sufficient velocity to overcome the retarding force of this negative gradient and will return to the cathode.

If the emission is adequate the electron flow will increase as the anode voltage increases, while the valve is working under space charge conditions. A voltage will eventually be reached, however, where the maximum possible cathode emission is all drawn to the anode and any further increase in anode voltage will produce no increase in current. The

valve is then saturated, or in a temperature-limited condition, and a further increase in anode current can only be obtained by increasing the cathode temperature. This well-known diode characteristic is illustrated in Fig. 4. As already stated, for most applications valves are operated under space charge conditions.

It can be shown that over the normal space charge operating region the anode current varies as the  $3/2$  power of the anode voltage.

#### Additional Effects of the Space Charge.

In addition to modifying the potential distribution the space charge affects the operation of the valve in other ways. It reduces the capacitance between electrodes

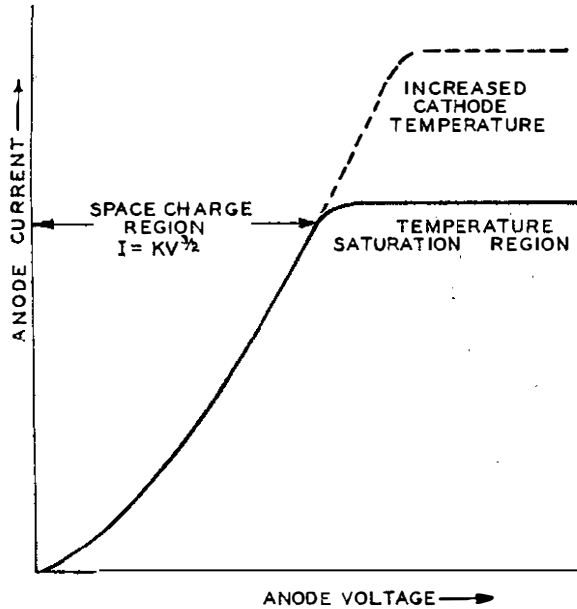

FIG. 4.—ANODE VOLTAGE/ANODE CURRENT CHARACTERISTIC OF THE DIODE.

and smooths out some of the fluctuations in the rate of emission of electrons, thereby reducing the shot noise in the valve. Apart from these two desirable features, it has the undesirable effect of increasing the effective electron transit time by 50 per cent.

### THE TRIODE

#### *Control of Electrons by a Third Electrode.*

The velocities of free electrons, both primary and secondary, and the paths they follow, are influenced by additional electrodes between the anode and cathode, and by the application of an external magnetic field. In the triode valve small variations in the potential of the open mesh grid have a greater effect on the electron stream than do similar variations of the anode potential, because the grid is closer to the cathode where the electron velocity is small, and the electrons are therefore influenced by the electrostatic field of the grid for a longer time. In most small valves the grid potential is never allowed to become positive and there is therefore substantially no grid current,\* but its open mesh allows the electron stream to flow through to the anode. By contrast, however, large transmitting valves are operated so that the grid swings positive during part of each cycle and there is appreciable power dissipated in the grid circuit.

Variations in the grid potential due to an applied signal produce corresponding changes in the anode current, and the resulting voltage variations obtained by passing the anode current through an external impedance can be much larger than the variations applied to the grid. The amplification of a signal in this way is, of course, one of the main functions of a valve.

\* The velocity of emission from the cathode causes a small grid current when the grid is only slightly negative.

The fundamental triode equation is approximately

$$I_a = K \left( V_g + \frac{V_a}{\mu} \right)^{3/2}$$

where  $K$  is a constant depending upon the geometry of the valve,  $V_g$  the grid voltage,  $V_a$  the anode voltage and  $\mu$  the voltage amplification factor of the valve.

#### *Reverse Grid Current.*

In a valve in which the grid is negatively biased, some of the positive ions produced by collisions between the free electrons and the remaining gas molecules in the vacuum are attracted to the grid, and the resultant grid current will reduce the negative bias unless the grid circuit resistance is restricted. If a very high grid circuit resistance is used, the effect may be sufficiently cumulative to swing the grid positive; it is therefore desirable not to exceed the maximum permissible resistance specified by a manufacturer. The magnitude of the reverse grid current is obviously one of the factors determining the degree to which the valve must be evacuated; indeed, it is often used to test the vacuum.

Additional grid current is also caused by grid emission arising from the deposition of active emitting material from the cathode during the formation of the oxide coating from the carbonates, while the valve is being pumped. Despite the greatest care in manufacture this contamination is extremely troublesome, particularly in high performance valves with small cathode-to-grid spacings, and the resulting grid emission can only be limited to a tolerable value by restricting the grid temperature to below about 600°K. For this reason the grid structure must be made of materials with good thermal conductivity and small cooling fins may have to be attached, despite the resulting increase in interelectrode capacitances.

Low insulation can produce a third contribution to the grid current and although pure mica, which is normally used to space the electrodes, has an adequate surface resistivity, it may become contaminated with a conducting element from either the cathode activation or the gettering process. A coating of magnesium oxide is useful in producing a matt surface which tends to break up the deposit and prevent it from forming a continuous conducting sheet on the surface of the mica.

The magnitude of the reverse grid current produced by these combined effects is usually of the order of  $10^{-7}$  ampere, and for a high performance receiving pentode the usual limit to the grid circuit resistance is 500,000 ohms.

### MULTI-ELECTRODE VALVES

The triode finds only limited application because the capacitance between the anode and grid electrodes often provides sufficient feedback to affect the operation of the valve seriously. This led to the introduction of an open mesh electrostatic screen between these electrodes, maintained at a D.C. potential of the same order as the anode. The characteristics of screened grid valves are, however, seriously modified by secondary electrons emitted from the anode and



attracted to the screen. This has been eliminated in the pentode valve by the introduction of an earthed suppressor screen between the anode and screen grid. An effective picture of the voltage gradients between the various electrodes of a pentode valve is provided by the use of potential profiles<sup>2</sup> as shown in Fig. 5.

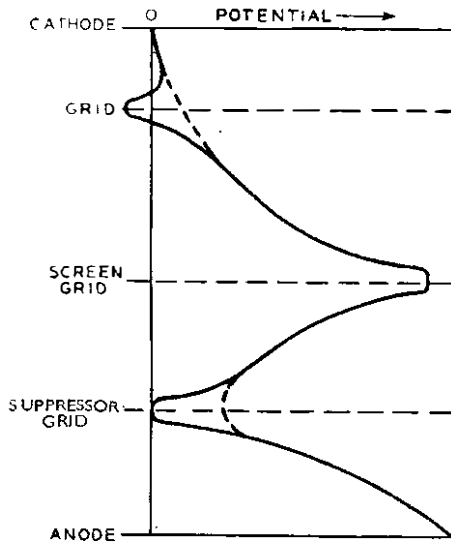

FIG. 5.—POTENTIAL DISTRIBUTION IN A PENTODE VALVE.

The solid lines show the potential distribution on an axis running through the grid wires and the dotted lines on an axis passing through the grid spaces.

For instance, such a diagram illustrates clearly the action of the suppressor grid. Primary electrons are accelerated while travelling from the cathode to the screen grid and they acquire sufficient momentum to carry them through the suppressor grid despite the retarding potential gradient between the screen

and suppressor grids. The electrons are then further accelerated by the positive potential gradient after the suppressor grid until they arrive at the anode, and the impact of the primary electrons on the anode results in the emission of secondary electrons. The movement of the secondary electrons in the direction of the cathode, namely, in opposition to the primary electron stream, is opposed by the potential gradient between anode and suppressor grid and their low initial momentum is not sufficient to carry them through the suppressor grid into what would be an accelerating potential gradient towards the screen grid. Instead they are slowed down and then attracted back to the anode; the secondary emission is thus effectively suppressed.

#### Contact Potential.

Contact potential is another phenomenon that has some effect upon valve performance and is due to the small potential that exists at the junction of two dissimilar metals. The differing work functions of the metals allow electrons to pass more freely across the junction in one direction than the other and the resulting accumulation of electrons on one side and the deficiency on the other give rise to a small potential difference equal in magnitude to the difference in the work functions of the metals concerned.

The potential is usually a fraction of a volt and can therefore only be of importance in the cathode-grid circuit or the anode circuit at very low voltages.

#### Conclusion.

This brief summary of the principles upon which a valve depends for its operation will, it is hoped, provide an adequate theoretical introduction to the more practical aspects of valve use to be dealt with in succeeding articles. For a fuller treatment of the physics of the valve the reader is referred to any of the standard textbooks<sup>3</sup> devoted to this field.

<sup>2</sup> K. R. Spangenberg. "Vacuum Tubes."

<sup>3</sup> e.g., L. R. Koller. "The Physics of Electron Tubes."

### TELEGRAPH AND TELEPHONE STATISTICS—SINGLE WIRE MILEAGES AS AT 31 MARCH, 1949. POST OFFICE MAINTENANCE—EXCLUDING SUBMARINE CABLE

| REGION                    | OVERHEAD              |           |              | UNDERGROUND            |            |              |
|---------------------------|-----------------------|-----------|--------------|------------------------|------------|--------------|
|                           | Trunks and Telegraphs | Junctions | Subscribers* | Trunks and Telegraphs† | Junctions‡ | Subscribers§ |
| Northern Ireland .. .. .  | 6,174                 | 6,314     | 37,900       | 108,406                | 47,068     | 146,975      |
| Scotland .. .. .          | 11,664                | 28,859    | 210,163      | 817,078                | 316,974    | 909,855      |
| Home Counties .. .. .     | 510                   | 13,249    | 385,031      | 1,925,252              | 575,704    | 1,539,655    |
| Midland .. .. .           | 2,198                 | 20,271    | 236,923      | 1,092,280              | 354,649    | 1,101,102    |
| North Eastern .. .. .     | 3,167                 | 13,691    | 204,072      | 889,398                | 311,078    | 1,079,995    |
| North Western .. .. .     | 988                   | 6,015     | 121,528      | 701,270                | 408,357    | 1,302,147    |
| South Western .. .. .     | 1,321                 | 21,813    | 291,663      | 1,023,892              | 230,619    | 858,374      |
| Welsh and Border Counties | 3,497                 | 16,038    | 164,464      | 536,762                | 134,122    | 352,942      |
| Provinces .. .. .         | 29,519                | 126,250   | 1,651,744    | 7,094,938              | 2,378,571  | 7,291,045    |
| London .. .. .            | —                     | 416       | 85,901       | 1,005,792              | 2,278,176  | 4,048,147    |
| United Kingdom .. .. .    | 29,519                | 126,666   | 1,737,645    | 8,100,730              | 4,656,747  | 11,339,192   |

\* Includes all spare wires.

† All wires (including spares) in M.U. Cables.

‡ All wires (including spares) in wholly Junction Cables.

§ All wires (including spares) in Subscribers' and mixed Junction and Subscribers' Cables.

# Music Circuits on the Phantoms of 12- and 24-Circuit Carrier Cables

H. J. MARCHANT, B.Sc., A.M.I.E.E.,  
and L. R. N. MILLS

U.D.C. 621.395.97 : 621.395.4 : 621.315.212

This article outlines the standard of performance required for music circuits and the method now widely used for their provision on the phantoms of 12- and 24-circuit carrier cables. The associated equipment is also described.

## Introduction.

MUSIC circuits as described in this article are those routed over the trunk network and rented by the B.B.C., Wire Broadcasting and Rediffusion services, for the transmission of programme material. At the present time such circuits are usually provided either on lightly loaded, or unloaded screened pairs, or on the phantoms of 12- or 24-circuit carrier cables, and both types of circuit meet the performance requirements for music circuits equally well. The music circuit network has, however, expanded very rapidly in recent years, and the simultaneous development of the carrier cable network has provided a ready means of meeting the growing demand for circuits for this purpose. Music circuits may be provided on these cables by four main methods, namely:—

- (a) Modulation of the programme material into a frequency band within the range of the 12- or 24-circuit system, or other wide band system.
- (b) The split band method.
- (c) Direct transmission of the music band in the range below 12 kc/s.
- (d) Direct transmission of the music band on the phantoms of the carrier cable pairs.

Method (a) has not been developed in the past in view of the complexity of the equipment required and the fact that other methods were more readily applicable, but the development of the coaxial system has led to a reconsideration of the problem, since methods (c) and (d) cannot be used on this system. The design of suitable equipment is now in hand, providing two unidirectional music circuits, one in each direction of transmission, at the expense of three "four-wire" speech circuits.

In method (b) the music band is divided into two or more parts which are transmitted over separate channels in the carrier or coaxial system<sup>1</sup>. The method necessarily degrades the quality of transmission and is used only in exceptional circumstances.

Method (c) has been adequately described elsewhere<sup>2</sup>. The filters required at each station are relatively complex and expensive and only a few systems are in use in this country. These will ultimately be used only on the Bristol-Plymouth carrier route employing the old type multiple twin carrier cables.

Method (d), as described in this article, has been adopted as the standard method for providing music circuits on carrier cables and is suitable for use with any type of 12- or 24-circuit carrier system. It provides twelve unidirectional music circuits in each direction of transmission on one pair of carrier cables.

## Performance Requirements.

The C.C.I.F. have specified certain limits for the performance of music circuits and these limits have been adopted by the British Post Office. A higher standard of performance, however, is frequently asked for by the renters, and although the Post Office only guarantees to provide circuits with performance figures falling within the C.C.I.F. limits, the higher standard is usually attained on carrier phantoms. (The C.C.I.F. have agreed that a larger bandwidth is desirable). The higher standard of performance may be summarised as follows:—

- (a) The circuit should transmit frequencies ranging from 50 c/s to 8,500 c/s with a response variation of not more than  $\pm 2$ db. after the effects due to variation in mean cable temperature have been allowed for. The corresponding variation between 100 c/s and 8,500 c/s should be not more than  $\pm 1$  db.
- (b) The noise level should be at least 60 db. below the maximum useful voltage when measured with a C.C.I.F. broadcast weighting network. The corresponding limit for unweighted noise should be 40 db. The noise should be measured at a point in the circuit where the line characteristic has been substantially equalised.
- (c) The signal/harmonic ratio should be at least 35 db., when a 100 c/s signal is applied to the circuit at a point of zero relative level, and at a level of 10 db. above 1 mW. When a signal of 1,000 c/s is used the ratio should be at least 40 db. For circuits longer than 100 miles these limits may be reduced.
- (d) Crosstalk and non-linear distortion should be negligibly small.

## Line Characteristics.

Twelve unidirectional carrier phantom circuits are obtained on each 24-pair carrier cable. The direction of transmission for the phantom circuits must be the same as that of the carrier circuits in order to minimise side-to-side and side-to-phantom crosstalk in the repeater station equipment. Normally the 24pr/40 lb. carrier cables are in quad formation and the two pairs of each quad are utilised for one phantom circuit.

Double phantom circuits are employed for miscellaneous purposes such as speaker circuits, alarms and supervisorys. When used for 4-wire speech circuits they are normally amplified, the direction of transmission corresponding to the direction of transmission of the phantom and side circuits, i.e., all "go" and "return" circuits will be in separate cables. When used as unamplified 2-wire circuits or for alarms, etc., they are cross-connected from one cable to the other at each repeater station so that in no circumstances are

<sup>1</sup>P.O.E.E.J., Vol. 31, p. 276.

<sup>2</sup>P.O.E.E.J., Vol. 31, p. 280.

low and high level points connected through by a metallic path.

Fig. 1 shows the attenuation characteristic for a

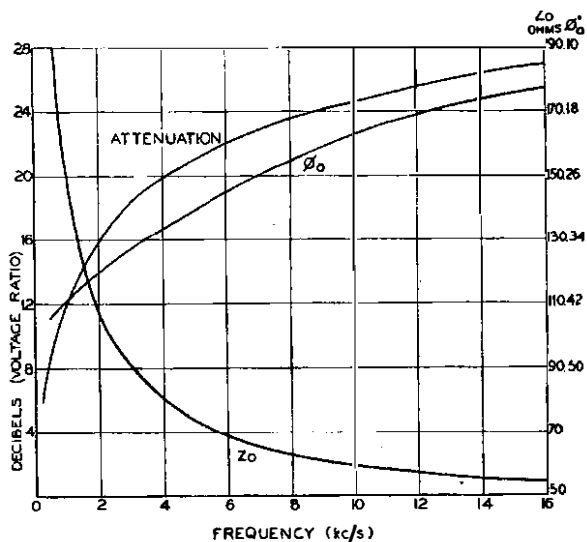

FIG. 1.—ATTENUATION AND CHARACTERISTIC IMPEDANCE OF 14-MILE CARRIER PHANTOM SECTION.

14-mile carrier phantom section. Modulus and phase angle of the characteristic impedance of such a section are also shown. Tests have shown that distant-end cable signal/crosstalk is better than 84 db. for a 22-mile section, at 8 kc/s. Side-to-phantom and phantom-to-side distant-end signal/crosstalk may be as low as 58 db., corrected for impedance differences, at 8 kc/s, which is sufficient to prevent the simultaneous use of the side circuits in the audio range and the phantom circuits for the transmission of music. It has little bearing however, on the simultaneous use of these cables for carrier and music transmission since the frequency ranges do not overlap. The section used for the crosstalk tests is one of the longest obtainable, and figures obtained on shorter sections are likely to be better than those quoted here.

#### REPEATER STATION EQUIPMENT

The repeater station equipment must provide for the derivation of the carrier phantom circuits from the side circuits, line equalisation and amplification and redistribution.

#### Cable Termination Bay.

The cable termination bay provides test tablets for the termination of the carrier cable pairs, and on the later type, cable crosstalk balancing frames. The phantom derivation coils are also provided on this bay. The double phantoms are normally derived from the line transformers on the amplifier equipment, but at stations where the phantom circuits are not amplified, double phantom derivation coils are provided on the cable termination bay. The line winding of Transformers 143AA are used for this purpose. The phantom derivation coils consist of Transformers

48E, the line windings of which are connected across the carrier cable pairs, and the phantom circuits are derived from the centre points of these transformers. The phantom coils may be disconnected if necessary by means of straps on the bay tag strips without interrupting the carrier circuits. In order to meet the more stringent return loss limits of the derivation coils consequent upon the introduction of 24-circuit carrier working, the Transformers 48E will ultimately be replaced by a bridging coil of new design.

#### Equipment, Amplifying No. 35.

The Equipment, Amplifying No. 35 provides amplifiers, equalisers and line transformers for 12 carrier phantom circuits, i.e. one 24-pair carrier cable, on one 10 ft. 6 in. bay side, and is designed to operate from normal repeater station supplies of 130 V H.T. and 21 or 6 V L.T. There are six Panels, Amplifying No. 35, and six Panels, Equaliser RP 1105, per bay side, together with the usual miscellaneous panels. The method of interconnection between the amplifier and equaliser panels and the bay connection strips is shown in Fig. 2. Screened cabling is used throughout and the earthing arrangements for the screens enable earth to be extended to the external cabling. Fig. 3 shows an Equipment, Amplifying No. 35, and Phantom Distribution Frame (referred to later).

*Panel, Amplifying No. 35.*—This consists of two unidirectional negative feedback amplifiers on a standard 19 in.  $\times$  8 $\frac{1}{2}$  in. panel and is shown in Fig. 4. A diagram of the amplifier circuit is shown in Fig. 5. The performance of the amplifier is as follows:—

- The gain of the amplifier is variable in steps of 1 db. from 50 db. to 20 db. The gain control is effected in two steps of 10 db. by means of tappings on the input potentiometer, and by 10 steps of 1 db. by tappings on the feedback resistance. The adjustments are made by soldered connections. The nominal gain with-out feed-back is approximately 90 db.
- The gain of the amplifier does not differ by more than  $\pm 1$  db. from the gain at 800 c/s over the range of frequencies from 30 c/s to 16,000 c/s at all gain settings.
- With an output power of 100 mW, the total harmonic content is not worse than 50 db. below the fundamental.
- The input and output impedances have a return loss against 600 ohms, greater than 20 db. in the frequency range from 500 c/s to 16,000 c/s. From 50 c/s to 500 c/s the input impedance has a return loss greater than 10 db. and the output impedance, greater than 8 db.

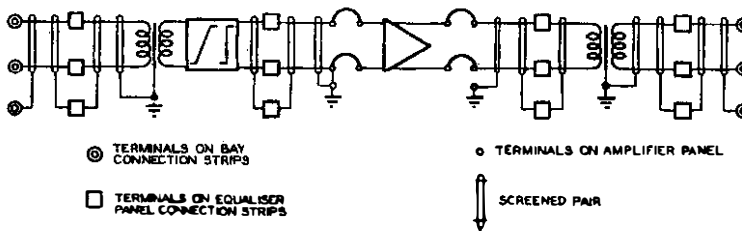

FIG. 2.—INTERCONNECTION BETWEEN PANELS ON EQUIPMENT, AMPLIFYING NO. 35.

- (e) With normal repeater station battery supplies, the amplifier noise output should not exceed 1 mV when measured with a psophometer

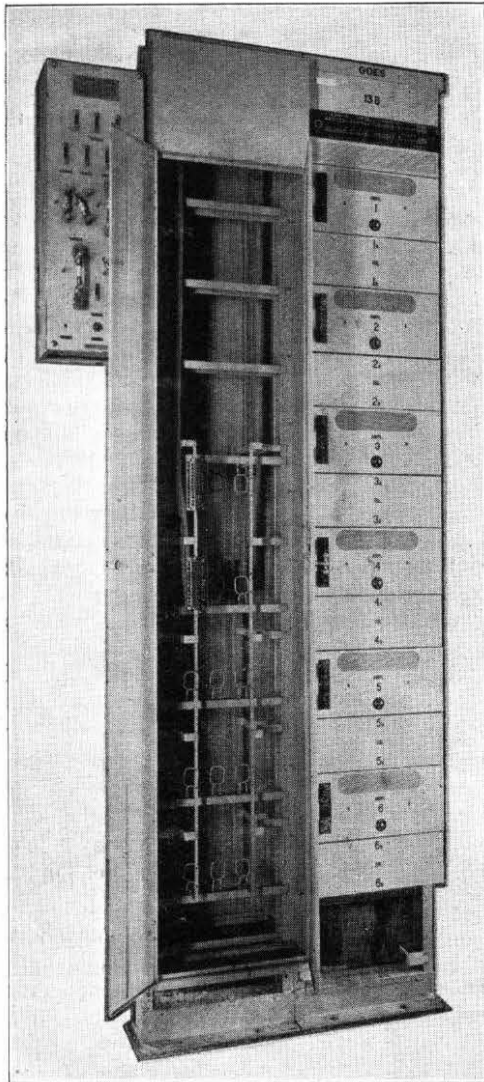

FIG. 3.—EQUIPMENT, AMPLIFYING No. 35 AND PHANTOM DISTRIBUTION FRAME.

incorporating the C.C.I.F. broadcast weighting network. In practice the noise output is usually less than 0.2 mV.

- (f) The crosstalk attenuation at 4 kc/s between the input of the disturbing amplifier and the output of the other is not worse than 40 db.

The input transformer has a 1 : 8 step-up voltage ratio and is double screened. Resistance-capacitance inter-stage coupling is used with a small capacitor across the grid resistor to improve stability at high frequencies. The output transformer has a 6.4 : 1 step-down voltage ratio. A third wind-

ing has a step-down voltage ratio of 160 : 1 from the valve output and provides parallel feedback which, when combined with the series feedback provided by the cathode resistor of the output valve, is applied to the input stage via a resistance-capacitance network. This network provides fine gain control and adjustable low frequency gain correction. The input and output transformers are so designed that their leakage inductances form low pass filter sections with fixed capacitors across the line windings and the distributed capacitances of the windings themselves. This arrangement increases the input and output return losses at the high frequency end of the effective frequency range.

*Panel, Equaliser RP1105.*—Each equaliser panel provides input and output line transformers and equalisers for two carrier phantom circuits, and is normally associated with one Panel, Amplifying No. 35. The panel is known as a Panel, Equaliser RP 1105, and the line transformers are Post Office type 143 designed to give minimum distortion in the music band of frequencies. There are three line/office voltage ratios namely 1 : 1, 1 : 1.87 and 1 : 2.74, and the particular ratio used depends on the length of the adjacent cable section.

The equaliser is made up of Equaliser Units No. 7. These are constant impedance equaliser sections which have been adequately described elsewhere<sup>3</sup>. The combination of units and settings and line transformers required for a particular section length has been standardised from the results of tests carried out on representative cable section lengths for all mileages up to 24 miles. The manufacturing tolerances of the cable are sufficiently close to enable this procedure to be adopted. The equalisation is arranged so that the cable section and associated equipment measured from the output of the corresponding amplifier at the next station will exhibit a constant insertion loss between 600 ohm impedances when the cable conductors are at a mean temperature of 20°C. The characteristics of all cables are substantially uniform and any errors occurring will be of a random nature, including those due to the fact that section lengths are approximated to the nearest mile for the purpose of assessing

<sup>3</sup>P.O.E.E.J., Vol. 32, p. 204.

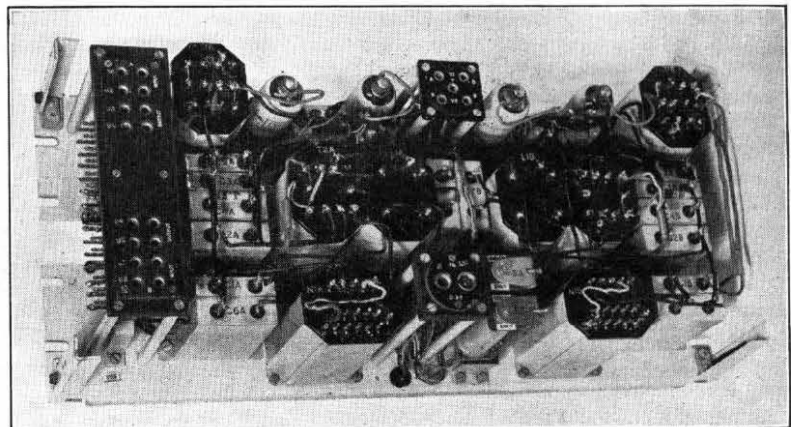

FIG. 4.—PANEL, AMPLIFYING No. 35.



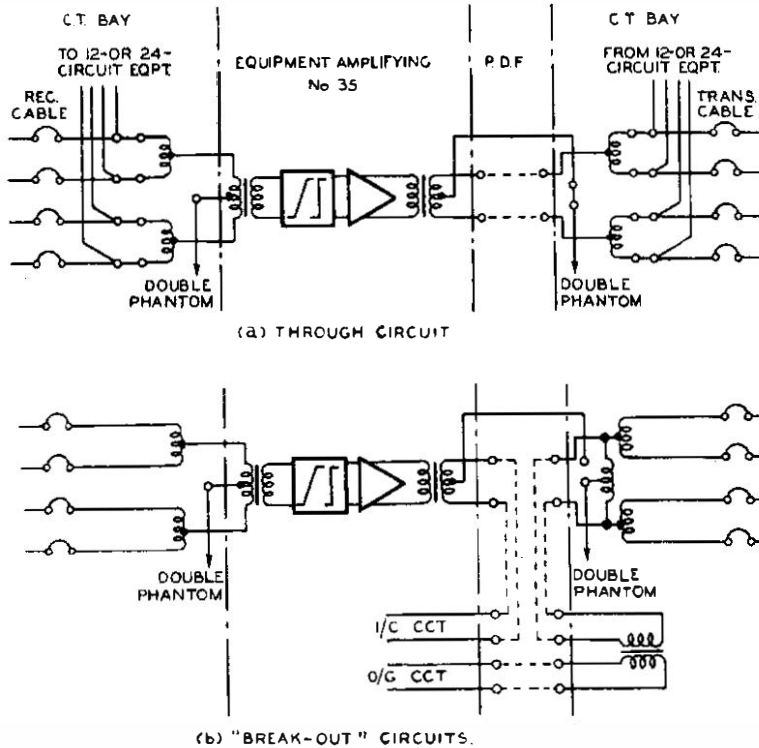

FIG. 7.—TYPICAL ARRANGEMENTS AT A "BREAKOUT" STATION.

In the past equalisation has been effected without correction to a particular temperature and any correction required has been introduced by the renter at his own premises for the complete circuit. The equalisers for all cable section lengths are now standardised and give a uniform insertion loss/frequency characteristic at 20°C, but correction for changes in temperature is still carried out by the renter. This means that the output level of all the intermediate amplifiers will vary with frequency in a manner dependent on the position in the circuit, and is unsatisfactory for the following reasons:—

- (a) A uniform insertion loss/frequency characteristic for all cable sections greatly facilitates maintenance.
- (b) If the circuit has been equalised at a high temperature, then at lower temperatures, the insertion loss of any length of cable will fall at the higher frequencies. Overloading can therefore occur at these frequencies, in the amplifiers at the distant end of the circuit, with a consequent deterioration in quality.

It is intended, therefore, that in the future the Post Office will provide the renter with circuits equalised within

$\pm 2$  db. over the normal frequency band irrespective of cable temperature variations and at the same time will ensure that the circuits are equalised within the same limits at all intermediate repeater stations. The circuits will first be equalised so that they exhibit an insertion loss/frequency characteristic which is constant with frequency at 20°C. For any mean temperature below 20°C, networks will be connected at selected stations on the circuit so that the frequency response at the output of all amplifiers is within the above limits. These networks have been designed to correct for a 20°C fall in temperature on an 8-, 12-, 16- and 20-mile section, and one network will be provided as part of each Panel, Equaliser RP 1105, to be connected in circuit as required, the network fitted depending on the length of the preceding cable section. All networks will be in circuit when the mean cable temperature falls to 0°C. In practice the mean temperature rarely falls outside the range of temperature from 2°C to 20°C. Fig. 9 shows a circuit diagram

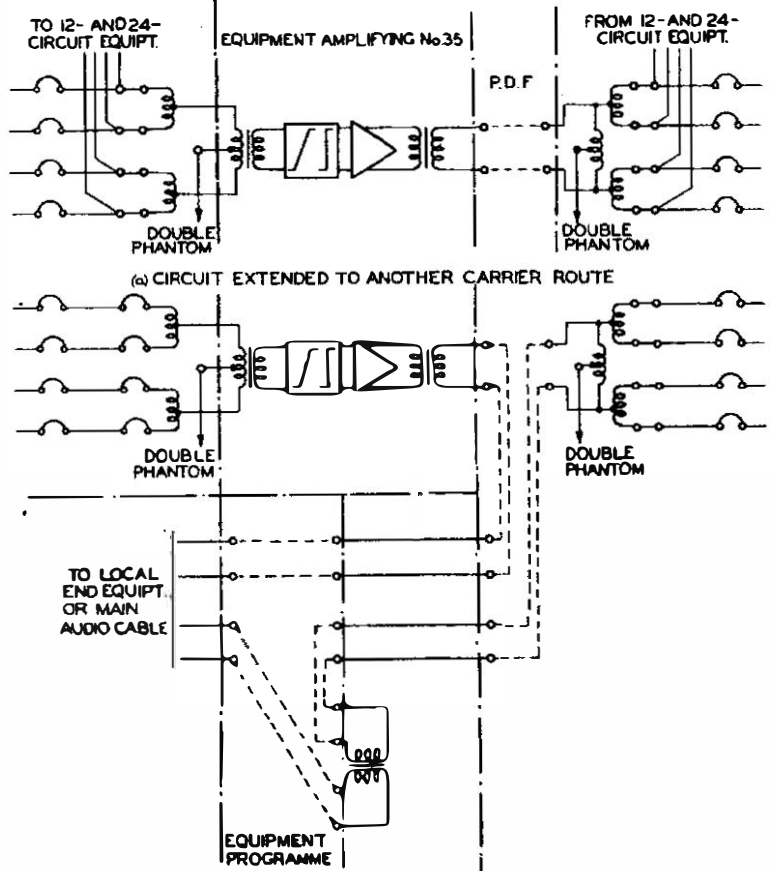

FIG. 8.—TYPICAL ARRANGEMENTS AT A TERMINAL STATION.

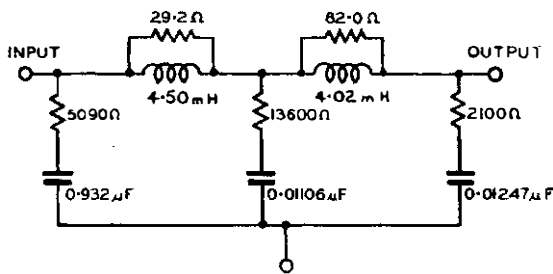

FIG. 9.—CIRCUIT DIAGRAM OF TEMPERATURE EQUALISER FOR 20-MILE CARRIER PHANTOM SECTION.

of a suitable network for a 20-mile section, and insertion loss/frequency characteristics are shown in Fig. 10 for all four types. These networks will be known as Equaliser Units Nos. 14B-14E.

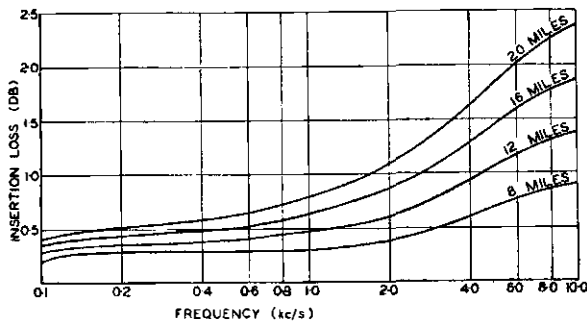

FIG. 10.—INSERTION LOSS/FREQUENCY CHARACTERISTICS OF TEMPERATURE EQUALISERS.

In practice, routine tests will be carried out to determine the insertion loss/frequency response characteristics of the circuits and the best locations for the temperature equaliser units to be wired into the circuit. It will be necessary, however, to distinguish

between changes in the frequency response characteristic due to temperature changes and changes due to a fault condition, and in order to do this the mean temperature of the cable must be determined. The variation of the D.C. resistance of the carrier phantom conductors with temperature is known from cable contractors' data, and the mean cable temperature can be calculated from D.C. loop resistance measurements on selected cable sections on the route. The B.B.C. also conduct daily tests on selected cables throughout the country and these, together with observatory readings on ground temperature, are available if necessary, to confirm Post Office observations on mean cable temperature.

#### Future Development.

The quality and standard of performance obtained with carrier cable phantom circuits is high. These circuits frequently carry B.B.C. programme material for large areas in Great Britain and also for the Continent. It is of the utmost importance, therefore, that the incidence of interruptions and faults be reduced to an absolute minimum, and the enthusiastic co-operation of the maintenance staff is perhaps the most important factor in this effort.

The design of new testing equipment is also in progress, which will enable the special performance of music circuits and the quality of transmission to be computed and intermittent faults rapidly located.

#### Conclusion.

The 12- and 24-circuit carrier cable network offers a ready means of providing circuits of high quality for music transmission on the cable phantoms, and the number of such circuits in use is increasing. It is hoped that this article has given a clear picture of the method used in providing such circuits and the standards of performance required.

## Book Review

"An Introduction to the Laplace Transform." J. C. Jaegar, D.Sc. Methuen's Monographs on Physical Subjects. Methuen & Co. 132 pp. 31 ill. 7s. 6d.

This book contains the substance of a course of lectures delivered by Dr. J. C. Jaegar to engineers at the National Standards Laboratory, Sydney, in 1944. It is intended as an introduction to modern operational calculus based upon the Laplace Transform. It is written for engineers who have a working knowledge of ordinary calculus, but are not familiar with the ideas of contour integration and the calculus of residues.

The book can be recommended to those who wish to acquire manipulative skill in the analysis of circuit problems: it is, in fact, largely a collection of worked examples illustrating the L.T. method of solution. In the first chapter various theorems associated with L.T.s are established and in the second chapter these theorems are used to solve problems which arise in the analysis of vibrating electrical and mechanical systems. These problems involve the transient analysis of bridge and filter networks as well as systems containing vacuum tubes; they also include the analysis of servomechanisms and geared systems, etc. Of course, the engineer who wishes to go deeply into these matters must study the

theory of functions of a complex variable and go far beyond the limits of this little book.

In the third chapter some of Heaviside's theorems are illustrated and the connection between Fourier's integral theorem and the Parseval theorem is described briefly. The fourth chapter contains a rather skimpy discussion of the L.T.s and the partial differential equations associated with continuous systems: this discussion is illustrated by transmission line analysis, and since the argument is from the viewpoint of the earlier chapters, it is consequently vague and inadequate in theoretical detail. The general difficulties attending the L.T. treatment of continuous systems have been discussed at length by Jeffreys and Kryloff; and although Kryloff has tried to formulate a full and rigorous theory of the operational solution of continuous systems his theory is not yet regarded as complete. A book written by Kryloff, devoted solely to an inclusive account of the present state of the operational theory of continuous systems, is greatly needed. It is probable that the preferred approach is through multiple L.T. theory. It is not generally known that Heaviside spent the last few years of his life trying to develop such a theory from the viewpoint of his impulse functions.

H. J. J.

# Hamburg-Hanover Coaxial Cable Scheme

J. FORREST

U.D.C. 621.315.212

The provision of telecommunication services in Germany during the immediate post-war period resulted in many problems for Posts and Telecommunications, Control Commission Germany. In this article the author, formerly with the Control Commission, describes the steps taken to overcome material shortages when additional Hamburg-Hanover circuits were required, by recovering and relaying armoured coaxial cable.

## Introduction.

IN January 1946, as a result of information received by Posts and Telecommunications, Control Commission Germany, it became evident that long-distance communications between Hamburg and other main centres in the British-American Zones of occupation would have to be considerably increased. Due to the Occupation the existing communications in the Westphalian plain area radiate from the Minden trunk exchange, which has a 60-position sleeve-control board installed by the Royal Signals, forming a Group Centre for military, Control Commission, and civil communications.

It was considered that plans should be made to establish an additional 150-200 four-wire circuits which would form a new backbone route and be

capable of extensions to all parts of Germany. Any such scheme required circuits additional to those provided by the existing Hamburg-Hanover main trunk audio cable, a 130-pair cable made up of varying diameter conductors, and the two 14/40-lb. unloaded cables Minden-Hamburg used for carrier working and completed in February 1946 by the Royal Signals. Laying a new cable was out of the question because there were no factories working in the British Zone capable of producing cables; any trunk, toll, or local cable that a rehabilitated factory could produce was required for the re-establishment of the cable network in the Ruhr alone. Thus the possibility of providing a new cable link between Hamburg and Hanover from sources within Germany was extremely remote.

Due to the severity of the winter season in the Northern sector of Germany, it was impracticable to erect and maintain an efficient and permanent aerial carrier route of sufficient size to provide the large number of circuits necessary and with these difficulties in mind it was apparent that recourse would have to be made to improvisation.

At this time information came to hand that portions of the Hamburg-Berlin and the Hanover-Berlin coaxial cables as laid prior to 1939 had been stumped at the boundary of the British Zone and it was proposed to utilise these to form part of a new coaxial link and so provide the circuits necessary for Military Government. Fig. 1 indicates the routes taken by these cables in the British Zone. To complete the new link between Hamburg and Hanover it was eventually decided to recover the Koln - Frankfurt cables between Koln and the French Zone, together with sections of the Hanover-Berlin cables, and relay them between Hanover and Masendorf (see Fig. 1). Additional repeater stations were necessary at Adelheidsdorf and Weyhausen.

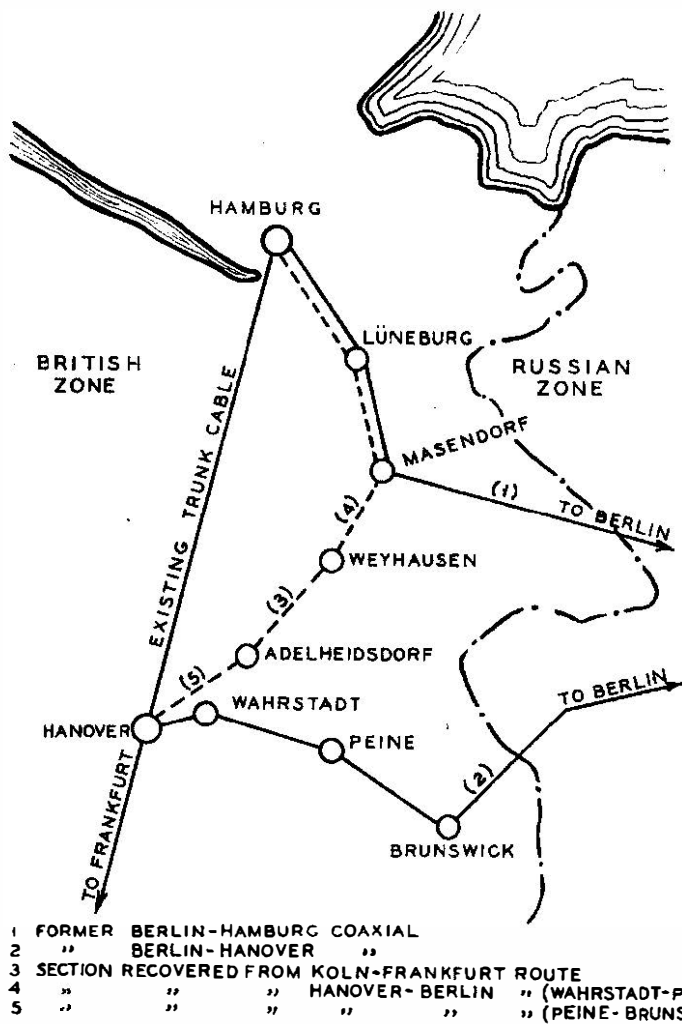

- 1 FORMER BERLIN-HAMBURG COAXIAL
- 2 " BERLIN-HANOVER "
- 3 SECTION RECOVERED FROM KOLN-FRANKFURT ROUTE
- 4 " " " HANOVER-BERLIN " (WAHRSTADT-PEINE)
- 5 " " " " " (PEINE-BRUNSWICK)

FIG. 1.—ROUTES TAKEN BY CABLES IN THE BRITISH ZONE OF GERMANY.

## Types of Cable.

Two main types of cable were dealt with during the operations, one having Styroflex as the insulating material, and the other "Frequenta" disc insulation of the ceramic type; both have cores of rigid construction incorporating additional pairs for music, carrier, and audio working, the whole being heavily armoured for laying direct in the ground.

The general appearance of the two types is indicated in Figs. 2 and 3 and brief



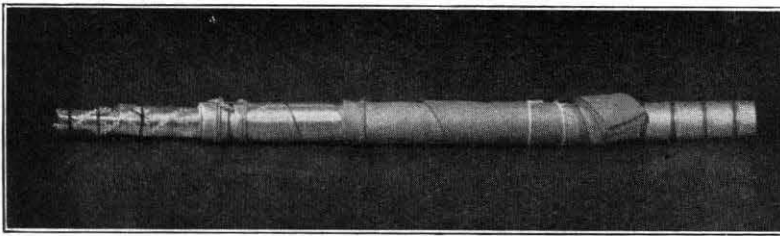

FIG. 2.—STYROFLEX CABLE.

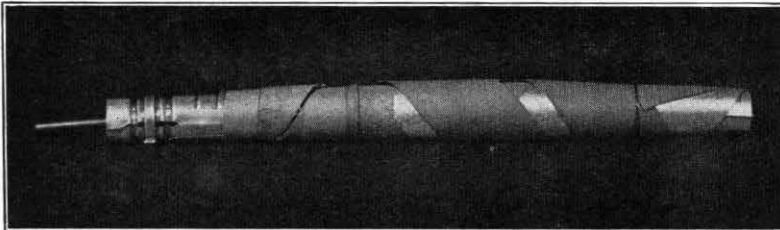

FIG. 3.—"FREQUENTA" DISC CABLE.

details of the constructional features are as follows :—

*Styroflex Cable.* In this cable the inner and outer conductors are insulated by a Styroflex insulant which is of the plastic type. Spirals of Styroflex are wound over the inner conductor followed by successive wrappings of the insulant. Such a method of insulation ensures a uniform temperature dissipation, and also permits the passage of free air along the conductor. This has a distinct advantage over the "Frequenta" disc type insulation, which, due to the uneven temperature dissipation, tends to cause a degree of inner conductor kinking with a possibility of short-circuiting of the two conductors.

The outer conductor consists of several pre-formed copper strips over which are laid two overlapping strips of copper.

*"Frequenta" Disc Cable.* The centre conductor of this cable is insulated by porcelain spacers which, by the design of the outer conductor, are spaced at intervals of 6 cms. Considerable difficulty was experienced in its initial laying due to the tendency of the inner conductor to kink in the unsupported section between the spacers.

In this cable it was found that, due to drumming and undrumming, the centre conductor elongates and special straining devices had to be fitted at the cable ends during manufacture to prevent contacts between the inner and outer conductors.

The outer conductor consists of interlocking linked copper sections over which are wound two copper strips, the whole being enclosed in two overlapping steel tapes.

In both cables, due to the rigid construction of the outer conductor, trouble was experienced when the armouring wires were applied. Under test it was found that the armouring shortens the cable, with the consequent danger that the rigid outer conductor is unable to conform to the stress placed upon it and tends to buckle. This fault was practically eliminated by lengthening the twist of the armouring wires.

Many such problems had been encountered during

the manufacture and laying of the cables, particularly as regards ensuring uniform electrical characteristics of factory lengths. For this reason the German engineers considered that a further drumming operation might damage the cable and seriously impair its electrical characteristics. This was a risk which had to be taken, however, and was justified by the urgency of the work.

#### *Excavating the Cable.*

The trenching and lifting operations were for the most part carried out by locally directed labour and a general survey of the type of cable excavated together with its length is indicated in Table 1. The problem of securing adequate and efficient labour was a continuous source of worry not only to the German Administration but also to the British personnel.

TABLE 1

|  | Section 1.<br>(Köln<br>—French Zone)                               | Section 2.<br>(Wahrstadt-<br>Peine)  | Section 3.<br>(Brunswick-<br>Peine) |
|--|--|--|-------------------------------------|
| Length of cable available for recovery(double track) | 98·821 km.   | 71·692 km.   | 64·190 km.                          |
| Type of Cable  | Styroflex  | Frequenta disc   | Styroflex                           |
| Average Cable lengths                                | 285 m.   | 282 m.   | 282 m.                              |
| Average depth at which the cable was buried          | 1 m. (in some places as much as 2·1 m.)                            | 1 m.   | 1 m.                                |
| Total length of cable lifted                         | 350 individual lengths = 95·297 km.                                | 252 individual lengths = 71·009 km.  | 222 individual lengths = 62·632 km. |
| Faults found during relaying                         | 52 pick punctures. 1 length crushed in 3 places by wheels of lorry | 2 pick punctures. 47 contacts or approaches between centre and outer conductor | 28 pick punctures                   |
| Relaying of cables mainly on sections                | Adelheidsdorf-Weyhausen  | Weyhausen-Masendorf  | Hanover-Adelheidsdorf               |
| Transport distance about                             | 400 km.  | 120 km.  | 70 km.                              |

Much effort was expended in recruiting workers from the area in which the recovery was taking place and even when the men were available they had to be equipped with boots, clothes and tools, all of which were in extremely short supply.

The winter 1946/47 was exceptionally severe. Temperatures in the open fluctuated between +20° and -30°C, and with such a combination of weather and labour it is not surprising that the fault incidence was high; some 82 pick punctures were discovered during the relaying operation. On the Wahrstadt-Brunswick section the cable was frozen into the ground, which delayed operations until the thaw set in. In the circumstances the percentage wastage to the total length of cable involved was extremely small.

The general procedure was as follows. Excavations were first made for the joint sleeves and condenser boxes. One squad of jointers cut the cable on each

side of the fitting and capped it ; during this operation the cable end was laid bare so that the inner conductor projected about 2 cms. beyond the cap and it was then bent over and soldered to the cap. The whole was then sealed by another sleeve. The fittings which were recovered were cleaned and then stored in special depots, but about 10 per cent. of the dismantled lead sleeves had to be abandoned due to damage during recovery. When the cable was uncovered it was lifted from the trench, laid by the roadside and then either coiled at once or, in frosty weather, left until the thaw had set in.

#### *Transport of Cable to New Location.*

Any one who visited Germany during the early period of the Occupation will realise the tremendous difficulties that beset any project involving the removal of heavy stores, either by road or by rail. In this particular instance, the cable had to be removed over distances of between 70 and 400 kilometres and this was in the main carried out by rail transport. Drums were difficult to find, particularly as a minimum diameter of 1.45 metres was considered the smallest that could safely be used. About 300 drums were found in the British Zone, and each drum was used approximately three times. The loaded drum weighed 2.5 tons and the removal from site, loading and unloading were effected without drum battens, a risk enforced by the impossibility of obtaining batten timber.

The loading and unloading of the complete drum were carried out by manual labour and considering the many difficulties the percentage of damage to cable during this operation was extremely low.

#### *Relaying the Cable.*

It was required to lay the following repeater station sections :—

|                         |            |
|-------------------------|------------|
| Hanover-Adelheidsdorf   | 34.934 km. |
| Adelheidsdorf-Weyhausen | 39.348 km. |
| Weyhausen-Masendorf     | 33.341 km. |

On an average between 45 and 55 men were employed in each section, and similar difficulties with labour occurred in the laying of the cable as were experienced in its recovery. In view of the many difficulties it was decided that the cable should be relaid as far as possible in secondary roads. Most of the cable trenching was carried out to a depth of some 30 cm. by a reinforced plough and the trench was then completed by manual labour to a depth of 0.8 metre.

The cable was man-handled from the lorry and laid down in the trench, no attention being paid to the location of joints or of loading coil boxes. The position of the loading coils required was then measured and the cable once again cut. Having determined the new cable lengths the necessary jointing was completed, and the cable pressure-tested at 1 atmosphere for one hour. After faults had been cleared the cable was tested with 1,500 volts D.C., to locate any contact or approaching contacts between the inner and outer conductor. When a fault was indicated, localisation tests were carried out by the Mathieson & Hockin method and the defective piece removed. As each individual length was tested and found in order the

trench was filled in and on completion of each repeater station section, impedance and attenuation measurements were taken.

#### *Test Results.*

Following the completion of the cable, circuits urgently required were routed over the new link immediately and only straightforward D.C. tests proving the cables to be free of contact were made before it was brought into use. Considerable difficulties were encountered in providing adequate audio transmission testing equipment as much was lost as a result of war operations and what little remained was quite often removed by the advancing troops. The position was still worse with regard to measuring equipment for the frequency spectrum required in coaxial working and all equipment that has been used for these tests to date has been built at the new Reichspost Research Station, mainly by cannibalising other equipment. It is for this reason that the test results are extremely limited and the German Communication Authorities are now designing precision equipment which will give more accurately the desired information. Various broad conclusions may be drawn, however, from the information already available and it can be stated that when the line-up of the two cables was completed between Masendorf and Hanover this did not differ unduly from the results obtained when the cables were laid initially. Although the results obtained to date indicate many irregularities as a result of moving the cables, experience in the field indicates that the cables are satisfactory for multi-channel working. It is extremely doubtful, however, with the numerous reflections recorded in the higher frequency spectrum, whether it would be possible to work the former television service over the coaxial tubes.

#### *Conclusions.*

The outcome of the experiment will not be fully revealed until the whole frequency range of the relaid cable can be accurately tested. Preliminary results indicate, however, that even with unskilled labour it is possible to excavate and re-lay armoured coaxial cable with some success. Although the cable is not of the same construction as that used by other Administrations, it is of interest to know that this type of modern cable can stand up to considerable mechanical disturbances, and still retain reasonable characteristics over a wide frequency range.

Since November 1947 the cable has carried 120 circuits between Hamburg and Hanover, which will be increased to 320 on completion of a further project between Hanover and Frankfurt.

#### *Acknowledgments.*

The project was initiated and designed at the H.Q. of Posts and Telecommunications division of the Control Commission Germany, the work being carried out by the Reichspost and the Deutsche Fernkabel-Gesellschaft in conjunction with, and under the general supervision of, British engineers. The author acknowledges with thanks permission of the Controller-General, P & T Division, to publish the results of the work.

# Ordnance Survey Maps

U.D.C. 912

F. SUMMERS, M.I.E.E., A.M.I.I.A.,  
and L. SLOMAN

A complete overhaul of the maps of Great Britain is now being undertaken by the Ordnance Survey and new-style maps are being published. This article describes the new maps and the extent to which the use of maps in the Engineering Department will be affected.

## Introduction.

ORDNANCE Survey maps are widely used in the Engineering Department. Their main use is as the basis of Line Plant Records, showing the geographical layout of the overhead and underground plant, but they are also employed for various other purposes, such as indicating corrosion areas, electricity high tension lines, etc., and for various boundary maps and special items such as Area of Search maps. Altogether the Engineering Department uses a very large number of Ordnance Survey maps—in fact, it uses more than any other body, though the number will probably be surpassed by the Ministry of Town and Country Planning and other new Ministries, in the near future.

The Ordnance Survey is now engaged on a complete overhaul of the maps of Great Britain and is producing new-style maps incorporating the National Grid. In view of the changes that are being made, it may be of interest to give an account of the various scale maps used by the Engineering Department, and to consider what differences will be brought about by the new maps.

### OLD-STYLE ORDNANCE SURVEY MAPS

The following scale maps and plans are now in general use :—

1/63360 or 1 in. to the mile.

1/10560 or 6 in. to the mile.

1/2500 or 25·344 in. to the mile, known as the 25 in. plan.

1/1250 or 50·688 in. to the mile, known as the 50 in. plan.

Various other scale maps are also used to a lesser degree.

The fractions above are known as Representative Fractions in that they give the true scale of the maps, where the numerator is a measurement on the map and the denominator is the corresponding distance, in the same units, on the ground.

In general, the overhead and underground plant owned by the Post Office is recorded on 25 in. plans, though in some built-up areas where the plant is congested the record is kept on 50 in. plans, and in isolated country areas where plant density is low the 6 in. map is found to suffice.

### One Inch Map.

It was in order to prepare a map of Great Britain on a scale of 1 in. to the mile, principally for defensive purposes, that the Ordnance Survey was formed in 1791. The task, since it was a military requirement, was given to the Board of Ordnance and was carried out by military personnel. Eventually the amount of civil work undertaken outstripped the military demands, and now the control of the Survey is with

the Ministry of Agriculture and Fisheries, although it has been with the Office of Works and the Ministry of Health. The military connection of the Ordnance Survey has still been retained, however, and a number of the officers hold military rank.

The 1 in. map in greatest use was known as the Third Edition Standard Map. This became obsolete some years ago but, to tide over the time until the issue of a new edition 1 in. map, reversed linen copies were obtained by the Post Office and these served for maintaining records and for making any prints that were required.

This map was very suitable for Post Office needs, as it was an outline map and was issued in a small sheet series. It had a uniform size and no overlap, and as such was very useful for recording routes of cables. For indexing, the maps were numbered as a series, and the sheet reference and numbers for Post Office purposes were based on these Ordnance map numbers.

### Six Inch Map.

This is the largest scale map which covers the whole of Great Britain. The adoption of this scale was the outcome of a demand, in the early 19th century, for a large scale map of Ireland, and a 6 in. survey of that country was undertaken by the Ordnance Survey. Its usefulness immediately provoked a demand for a 6 in. map of Great Britain and a survey of the Northern Counties of England was started. This was followed by a call for an even larger scale, from which the 25 in. plan emerged. The preparation of the 6 in. maps was continued, however, but they were derived from the 25 in. plans where these were available.

The 6 in. map has all the ground features represented correctly to scale, with the exception of certain streets which have been widened so that street names may be shown. This is the only distortion compelling the use of the term "map," instead of "plan."

This map has proved extremely popular, particularly in connection with engineering projects, where the contour lines have been found to be of great value. It has also been widely used by many bodies where illustrations having a map foundation have been required.

### Twenty-five Inch Plan.

Since the introduction of the large scale plans, the survey for all agricultural and urban areas has been based on the 25 in. scale; mountains and moorlands were treated exceptionally, however, and were mapped at a scale of 6 in. to one mile.

The 25 in. map is a true plan, in that all detail shown is drawn correctly to scale, and each plan covers a territory of 960 acres enclosed by a rectangle  $1\frac{1}{2}$  miles by 1 mile, the actual plan measuring approxi-

mately 38 in. by 25 in. There is no counterpart of this plan anywhere in the world, for no other country publishes nearly the whole of its territory on so large a scale. The number of different 25 in. plans that have been issued is just over 51,000. During the war, certain members of allied armies stationed in this country expressed surprise and admiration on seeing these comprehensive plans.

The method of numbering and indexing these sheets does not treat the country as a whole, but on a county basis. The reason for this is that at the time of the original survey, knowledge of mapping was not so advanced as nowadays, and in order to avoid distorting detail when the curved surface of the earth was depicted on the plane surface of the map, the method of projection then used required each county or group of small counties to be surveyed using a different reference meridian.

When the survey was completed there were 42 of these meridians, but by subsequent amalgamations this number was reduced to 39. Thus, there were published 39 separate county series of plans, each on its own origin, in which work was plotted only up to the boundaries of each area, and the remainder of the sheet left blank. When changes are made in county boundaries, there are difficulties in transferring the detail from a sheet in one series to a sheet in another, since the affected detail cannot be fitted in without recomputation and replotting due to the use of different reference meridians. This is a costly business, and leads to loss of accuracy. Fig. 1 is an

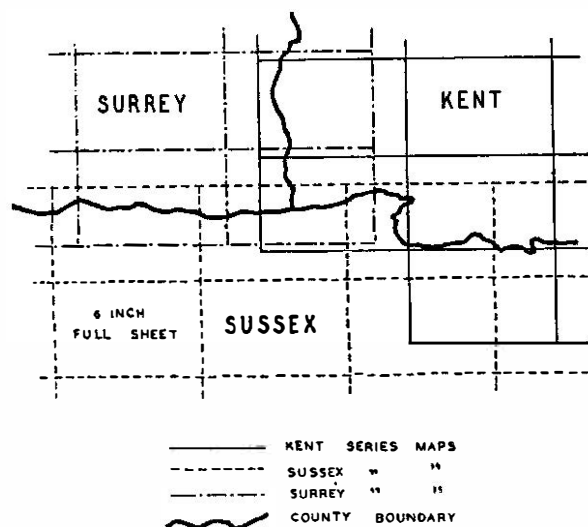

FIG. 1.—INCIDENCE OF ADJACENT SHEETS AT COUNTY BOUNDARIES OF KENT, SURREY AND SUSSEX.

example of the incidence of adjacent sheets at county boundaries.

Through the vagaries of national economy, and the effects of world affairs, these plans have unavoidably suffered from lack of revision, particularly in the areas where there has been a great deal of housing development. As far as possible the local Area Office linen copies of plans used by the Post Office, have been kept up to date by including such information on estates

and new roads that could be obtained from local authorities.

#### *Fifty Inch Plan.*

Plans to a scale of 50 in. to the mile were first produced by the Ordnance Survey as a result of a demand for plans of a larger scale than the 25 in., to be used for land valuation purposes in urban areas. They were printed from photographic enlargements of the 25 in. plans.

Enlargements of the 25 in. plan to 50 in. or to other scales are now undertaken by the Post Office Engineering Department. Firstly, a negative is made from a print of the required area. Next, the negative is projected by an enlarger to the required scale. The enlargement is produced on thin bromide paper which is then used to obtain a linen copy by the true-to-scale process.

As these larger scales are straight unadapted enlargements of the 25 in. plans they have only the same accuracy and detail, and the lines are rather coarse. The chief advantage, however, lies in the provision of more space for recording information, which would be congested at a smaller scale.

Plans have been produced at scales greater than the 50 in., namely, at 5 ft. and 10 ft. to the mile. These plans were of greater benefit to municipal authorities than to the Government or the general public and, as they were costly to produce and maintain, it was agreed that the Ordnance Survey should cease to be responsible for them. Local authorities, however, were given the opportunity of retaining surveys of their areas at these scales, and the Ordnance Survey agreed to carry out the work if the local authorities were willing to defray the cost over and above that of a survey on the 25 in. scale. Some towns availed themselves of this arrangement but many have preferred to carry out their own revisions. Plans of London to a scale of 5 ft. to the mile are available, but these will become obsolete as the new series plans at 50 in. to the mile are issued; reference to these is made later.

#### *Relationship in Sheet Sizes.*

The county series maps, being built up within the limits of what amounts to a local survey, have their vertical sheet lines running almost True North, and there is a set ratio between the areas covered by the sheets of the 6 in. maps and the 25 in. and 50 in. plans.

The original 6 in. sheet covered the same territory as sixteen 25 in. plans and was given a title which consisted of the county name and a Roman numeral (e.g. ESSEX XIX). The 25 in. plans within this area were numbered from 1 to 16 (e.g. ESSEX XIX.2.). Subsequently the 6 in. map was divided into four and issued as quarter sheets (e.g. ESSEX XIX.N.E.). The 25 in. plan is divided into four to produce the 50 in. plans of the same sheet dimensions (e.g. ESSEX XIX.2. N.W.).

A  $\frac{1}{4}$  in. map, having the sheet lines overprinted, is published county by county, for use as an index to the maps described above. Fig. 2 shows how the large scale maps on the county basis are inter-related.

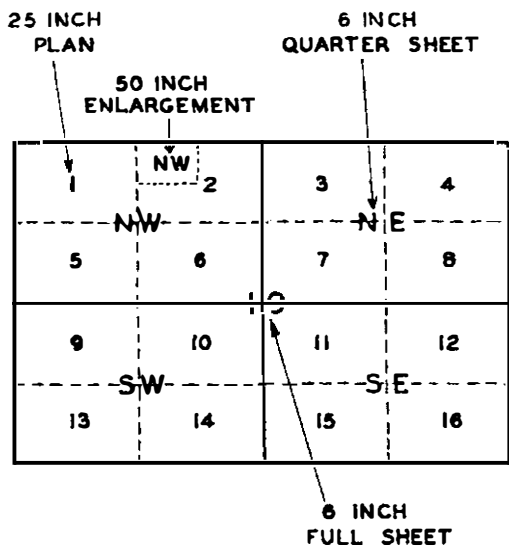

FIG. 2. —RELATIONSHIP BETWEEN LARGE SCALE MAPS ON THE COUNTY BASIS.

DEPARTMENTAL COMMITTEE ON THE ORDNANCE SURVEY

The foregoing gives a brief description of the maps the Engineering Department had in general use at the time a committee, under the chairmanship of the Rt. Hon. the Viscount Davidson, was appointed to consider what could be done to accelerate and maintain the revision of Ordnance Survey maps and to review the scales and styles of the maps.

*Recommendations of the Committee.*

The Davidson Committee produced its final report in 1938, and among its recommendations were the following:—

That the county basis of the 25 in. survey should be recast on a National Projection.

That a National Grid should be superimposed on all large scale plans, and with certain exceptions on smaller scale maps, to provide one reference system for the whole country.

That the grid should be based on the international metre and that medium and large scale maps should be published square in shape.

That a new medium scale map of 1/25,000 should be published.

That the scale of the 6 in. maps should be retained.

That investigations should be made as to whether urban areas require a survey on the 1/1250 scale.

These by no means exhaust the list of recommendations but they indicate to some extent the changes that were to be made.

The carrying out of these recommendations was interrupted by the Second World War, when war maps became the first consideration, and only recently has the transitional stage to normal production been passed.

NEW-STYLE ORDNANCE SURVEY MAPS

*Single Projection.*

The use of a single projection to cover the whole of Great Britain is the foundation on which the current Ordnance Survey programme is built, and the projection known as the Transverse Mercator Projection has been adopted. It is based on a central meridian 2°W with origin at latitude 49°N; the scale on this projection increases slightly to the east and west of the central meridian, and it is the same locally in all directions. Horizontal angles which are observed over distances of local surveys are the same as if they were computed directly from their rectangular co-ordinates and no intolerable distortion is introduced even at large scales.

As the sheet lines are based on the National Grid, with the single projection the departure of the sheet lines from True North will increase with the distance from the reference meridian; and it will vary also with the distance north of the origin. To indicate this variation, the bearing of True North is given on all maps.

*National Grid.*

The National Grid consists of a series of squares superimposed on the maps, the sides of the squares being parallel and at right angles to the central meridian chosen for the Transverse Mercator Projection. The false origin of the grid lies a little to the south-west of the Scilly Isles and the ordinates of the grid are measured in metric units, eastwards and northwards from this false origin.

When the units to be used for the National Grid were determined, it was desired to have a unit that would enable grid squares to be easily subdivided, either by eye or by measurement, for the interpolation of additional grid lines. The metric system was the natural choice, and since all points on the mainland of Great Britain lie within 1,000 kilometres of the origin, the number of figures in each ordinate is limited to six. The northern islands, however, lie outside this range and in cases where the north ordinate is more than 1,000 kilometres the letter N is prefixed.

In the same way that a point on a graph may be described by its co-ordinates, any point in the country can be given by its grid reference, which is an indication of the distance of the point east and north of the false origin. As the same reference system applies to all scale maps any point acquires a unique map reference which remains the same whatever scale of map is in use. The interval between the grid lines shown on the map depends upon the scale, for while it is convenient to show grid lines at 100 metres interval on a 25 in. plan, on a 6 in. map the interval is increased to 1 kilometre to prevent obscuring the topographical detail.

The principle of grid references is illustrated in Fig. 3. To determine the reference number of a given point to the nearest metre, the distance from the origin is given thus, 562,685 E. and 126,897 N.—the former figure is termed the "eastings" and the latter the "northings." On a map where the grid lines are spaced at 1,000 metres, the point of junction of

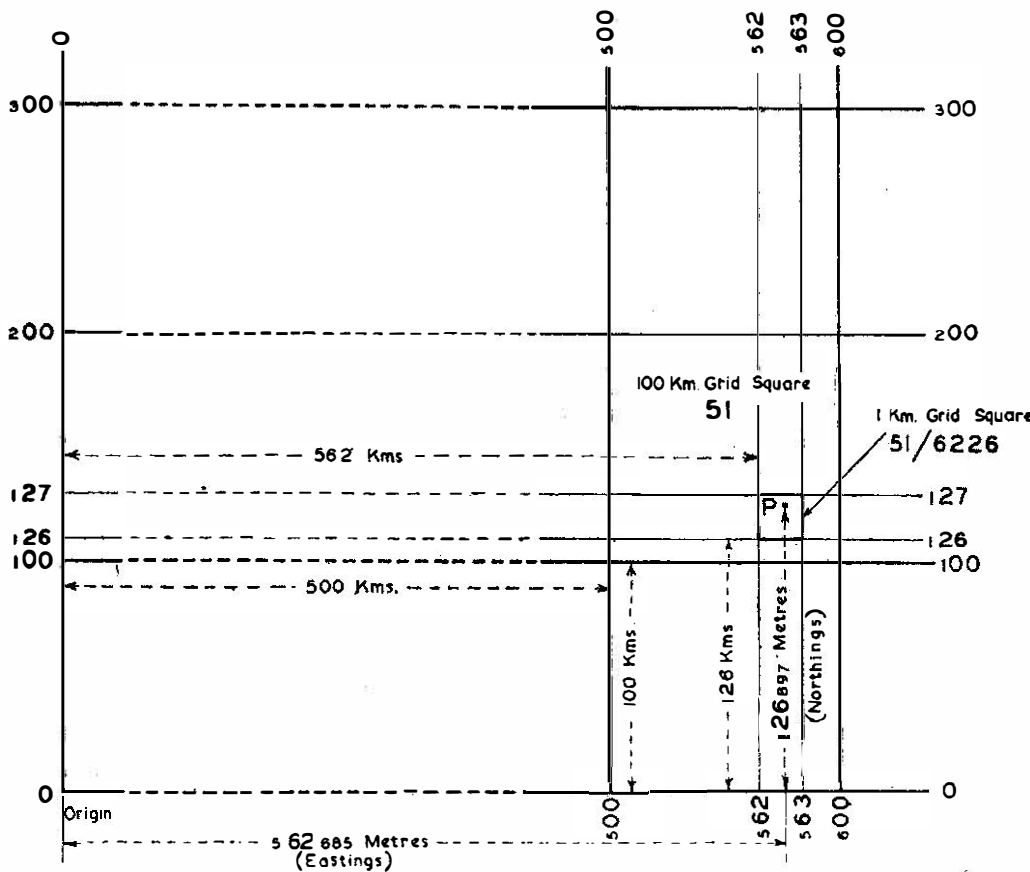

FIG. 3.—LOCATION OF A POINT FROM ITS GRID REFERENCE (NOT TO SCALE).

the lines 562 E. (drawn from the north to the south margins) and 126 N. (drawn from the east to the west margins) would be the bottom left-hand corner of the one kilometre square in which the given point would appear. To locate the point precisely, it is then necessary to measure 685 metres east from the left edge of the 1 kilometre square and 897 metres north from the bottom edge of the square.

On maps and plans every grid line is numbered to facilitate the location of any particular point. By arranging the digits thus, 562,600, the hundreds of kilometres (the first figure in small type) are readily identifiable, as are also the number of metres (the last three digits in small type). On 1 in. and smaller scale maps the lines are numbered in kilometres, i.e., the last three digits in smaller type are not shown.

#### Grid References on Maps.

When applying the system of grid references, if the "eastings" are always given first, the letters E and N may be dropped, thus 562685, 126897. This notation has been adopted as standard practice and the reference is in fact stated as a single number thus, 562685126897, this being to the nearest metre. It is not possible, however, to locate a point to this degree of accuracy on maps of scales under 6 in. to the mile, and where it is sufficient to quote a position, say, to the nearest 100 metres, the last two figures of each ordinate may be dropped thus, 56261268. The number

of digits in the reference therefore will depend upon the degree of accuracy required.

The Ordnance Survey felt that even with this curtailment the reference number appeared formidable, and it was desired to reduce to a minimum, the number of digits contained in a grid reference. To this end it was considered that if the country is first divided into 100 kilometre squares and if the location of a point is known to within a specific 100 kilometre square, the first figure of each ordinate representing the hundreds of kilometres may be dropped, thus 626268; this is known as the Normal National Grid Reference. Such a reference will apply, however, only to within the specific 100 kilometre square and should it be desired to quote what is known as the Full National Grid Reference,

the figures representing the hundreds of kilometres must be inserted; this is done by placing them in front of the reference number but separated by an oblique stroke thus, 51/626268. Fig. 4 shows the 100 kilometre grid lines which cover Great Britain, the numbering of the squares and the reference meridian upon which the grid system is built, i.e. longitude 2° W, which is shown in emphasis.

#### Grid References on Plans.

When it is desired to give grid references precisely, large scale plans are essential. A full reference to the nearest metre such as 51/6268526897 is very cumbersome for ordinary use, however, and since it contains certain figures which specify the particular sheet, they will apply to any point on that sheet. It is convenient in most cases to give a reference which will pertain to a specific 25 in. plan (which is based on an area 1 kilometre square and gridded at 100 metres interval) and therefore the grid reference to the nearest metre, measured from the south-west corner of that plan is expressed thus, 685897. Where the Full One Metre Reference is needed the number of the sheet is prefixed thus, 51/6226/685897. This method of quoting the reference applies only to large scale plans, i.e. 25 in. and 50 in.

A summary of the various forms of the grid references employed on the different scale maps is set out in Table I, the same point being used for each reference.

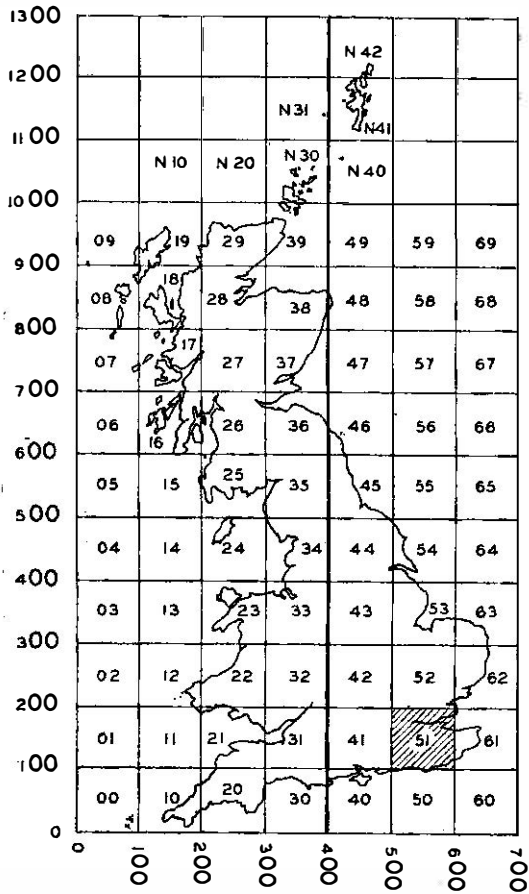

FIG. 4.—100 KILOMETRE SQUARES WHICH COVER GREAT BRITAIN, EMPHASISING SQUARE 51.

TABLE I  
SHOWING THE VARIOUS KINDS OF GRID REFERENCE.

| Degree of Precision  | Scale of Map   | Grid reference | Name of reference                  |
|--|----------------|----------------|------------------------------------|
| 1000 metres square<br>e.g. area covered<br>by a 25 in. plan. | 1", 2½" and 6" | 6226           | Normal Kilometre<br>Reference.     |
|  |                | 51/6226        | Full Kilometre<br>Reference.       |
| 100 metres square<br>e.g. large building<br>or plot of land. | 1", 2½" and 6" | 626268         | Normal National<br>Grid Reference. |
|  |                | 51/626268      | Full National<br>Grid Reference.   |
|  | 25" and 50"    | 68             | Hundred Metre<br>Reference.        |
|  |                | 51/6226/68     | Full Hundred Metre<br>Reference.   |
| 10 metres square<br>e.g. small building                      | 25" and 50"    | 6889           | Ten Metre Reference.               |
|  |                | 51/6226/6889   | Full Ten Metre<br>Reference.       |
| 1 metre square<br>e.g. joint box                             | 25" and 50"    | 685897         | One Metre Reference.               |
|  |                | 51/6226/685897 | Full One Metre<br>Reference.       |

NOTE.—The co-ordinates (in metres) of the point to be located are 562685 E 126897 N.

The grid lines on large scale plans are subdivided decimally at the plan edges and this enables the grid references to be calculated more readily, whether by eye or by measurement.

The use of the grid overcomes the difficulty of measuring accurately the distance between two points on a map when the paper has suffered expansion or contraction due to changeable atmospheric conditions. By fixing the co-ordinates of the points in question a simple calculation gives the distance accurately and can be extended over more than one plan. This has an advantage in Post Office work and will be of value in the measuring and calculation of radial mileages.

#### Indexing of Maps and Plans.

In order to extend the National Grid to a single indexing system it is necessary to make the sheet lines of the maps and plans coincide with grid lines, and to make the maps convenient multiples or sub-multiples of one another. This is done in all scales with the exception of the 1 in. and smaller scale maps, and examples of the indexing applied to the various scale sheets are given :—

- 2½ in. (1/25000) — 51/75
- 6 in. (1/10560) — 51/75 S.E.
- 25 in. (1/2500) — 51/7654
- 50 in. (1/1250) — 51/7654 N.W.

As already indicated, the figures 51 preceding the oblique stroke indicate the particular 100 kilometre square, and the figures following the stroke are the grid reference of the bottom left-hand corner of the map sheet. It will be evident, from previous explanations, that when two figures follow the oblique stroke the number refers to a plan 10 kilometres square; similarly, when four figures follow the oblique stroke it refers to a plan 1 kilometre square. An index to the 2½ in. and 6 in. map is obtained by subdividing the 100 kilometre squares as shown in Fig. 5, and in the

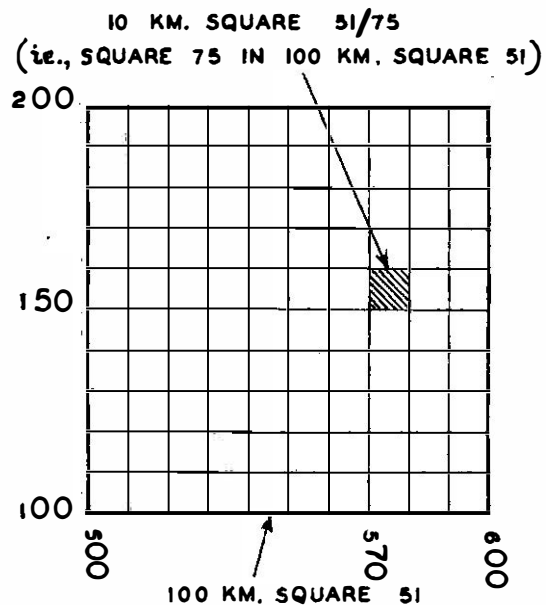

FIG. 5.—100 KILOMETRE SQUARE 51 SHOWING 2½ INCH MAP 51/75.

same way the 2½ in. map is a convenient index to the 25 in. and 50 in. plans.

The 6 in. map takes the same index number as the 2½ in. map, but since the former covers one quarter

of the area of the latter, it is suffixed by one of the following, N.E., N.W., S.E., or S.W. Similarly, the 50 in. plan covering one quarter of the area of its parent 25 in. sheet takes the same number, but with

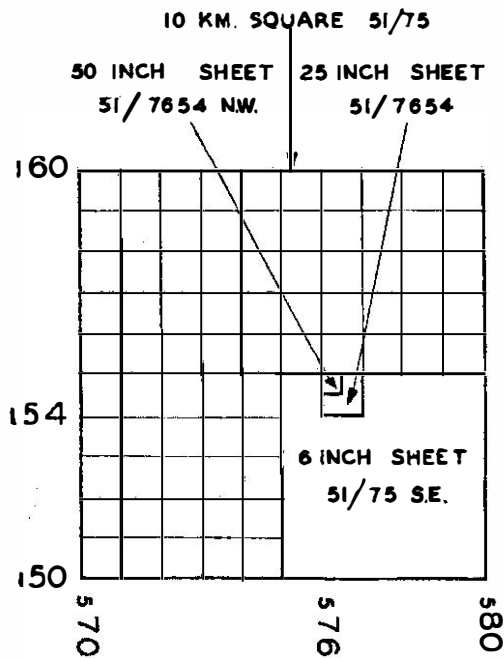

FIG. 6.—SHEET 51/75 OF 2½ INCH MAP INDICATING ITS RELATIONSHIP WITH THE LARGER SCALES.

the appropriate suffix. Fig. 6 indicates the relationship of the 2½ in. map with the larger scales.

On the 1 in. maps the grid lines are 1 kilometre apart and consequently these maps are a complete index to the new 25 in. plans. As the 10 kilometre lines are emphasised they are also a complete index to the 2½ in. maps.

#### One Inch Map.

The 1 in. map as now issued by the Ordnance Survey is the Sixth (New Popular) Edition and all its sheets are of standard size covering an area 40 kilometres by 45 kilometres, which gives the map the following dimensions—24.85 in. west to east and 27.96 in. south to north. Since each map was arranged so as to embrace as much territory as possible there is considerable overlapping of many of the individual sheets. This constitutes a major difficulty when used for plant records. In this connection, reference is given later to the special arrangements made with the Ordnance Survey for supplying a 1 in. map suitable for Post Office purposes.

There are two editions of the New Popular 1 in. map, namely, a coloured edition and an outline edition. The latter is published for those who require an outline for overdrawing and reproduction. This is important when map detail is copied photographically, for if a coloured edition map is used to obtain a linen copy, the roads, which are coloured, reproduce in black, thus making it unsuitable for plant records.

#### Two-and-a-half Inch Map.

Because of the considerable gap between the scales of the 1 in. and 6 in. maps, the Davidson Committee felt that the introduction of a new scale at 2½ in. to the mile would provide a map giving sufficient detail to be of great value to schools and planning authorities, as well as to the general public as a map for use when walking.

During the war a map of this scale was prepared for military purposes and, although hastily produced, it was so favourably received that a decision was made to introduce a specially designed map of the whole country. Until the regular edition of this map can be produced a Provisional Edition is being published, based on the old 6 in. map. The dimensions of the map detail on a normal sheet are approximately 15¾ in. square, which represents an area 10 kilometres square, and thus it covers the same territory as one hundred 25 in. plans. At coastal areas, however, there are some sheets where a few kilometres have been added to economise in the total number of sheets.

The 2½ in. maps have the National Grid lines spaced at 1 kilometre intervals, and they are printed in three editions. These are a coloured edition showing contours, classes of roads, etc., an outline edition showing bare map detail printed in grey and an edition which is similar to the outline map, but has the various local authorities' boundaries overprinted in red.

It is thought that the 2½ in. outline map printed on linen would be of great value as an Exchange Area Key Plan, since, in addition to showing map detail, it is in itself an index to all other plans in the neighbourhood, but special arrangements are necessary in some cases to contain the whole of an exchange area on a single sheet.

#### Six Inch Map.

The Davidson Committee considered the possibility of introducing, in place of the 6 in. map, a new scale map which, whilst retaining the same characteristics, would have a decimal relationship with the 1/2500 scale series. Accordingly, a map to a scale of 1/12500 (approximately 5 in. to the mile) was suggested and maps of this scale, having the same sheet dimensions as the 1/2500 scale, would cover an area 5 kilometres square. However, in spite of the advantages the adoption of this new scale would have given, it was found that there is such a widespread and popular use of the 6 in. map, and objections to a change were so strong, that it was decided to retain the 6 in. scale for the new series of maps. Its size was chosen as covering an area 5 kilometres square and the map detail dimensions are approximately 18 in. square, rather larger than the other standard maps. It covers the same territory as twenty-five 25 in. plans.

Until the survey of the country is completed Provisional Editions of the 6 in. maps, based on the county series maps, are being issued. For the London Area the maps are being produced on the new sheet lines, while for the rest of the country the maps are being printed on the old county sheet lines but with the National Grid added. These Provisional Editions will enable the advantages of grid references



to be had at this scale as early as possible. They contain certain detail which, being added to the map quickly during the war, is not up to the usual high standard of the Ordnance Survey as it is shown in a more generalised form. These areas can be easily recognised.

#### *Twenty-five Inch and Fifty Inch Plans.*

Sufficient has been said to show that for ease in indexing and identification of plans they should be square in shape, with the grid lines coinciding with the plan edges. The new 25 in. plan will cover one square kilometre of country, the plan detail dimensions being approximately  $15\frac{3}{4}$  in. square. The 50 in. plans have the same sheet dimensions, each plan covering an area 500 metres square. The new 50 in. plan will not differ greatly from the old 25 in. series in respect to detail and style, but the larger scale enables clarity to be attained in the densely built-up areas and there is one innovation—the insertion of the names or numbers of individual houses—which will be of great value to the Engineering Department. The high cost of surveys by the engineering staff in the course of providing service for new subscribers is causing some concern, and means are being devised to reduce this expense; the actual identification of premises on plans in the office will assist greatly in this connection. In pursuance of this idea it has been suggested that even where 50 in. plans are not available, the 25 in. plans could be marked up to show the identification of a limited number of houses, as opportunity occurs.

#### *Resurvey of Great Britain.*

It is inevitable that the new survey will take many years to cover the whole of Great Britain and until the new maps are ready certain Provisional Editions are being made available as already explained. For certain areas where maps are very much out of date, rectified air photographs have been prepared at scales corresponding to the 6 in. and 25 in. The photographs are based on the same sheet lines as the new series and are approximately to scale.

In rural areas the 25 in. plans are to be overhauled either by direct survey on the ground or from aerial photography, and the 6 in. and  $2\frac{1}{2}$  in. maps will be derived from these plans. The survey of town areas is now proceeding and 50 in. plans based on this survey are in course of issue. From these plans the 25 in. plans and medium scale maps of the town areas will be derived.

Hitherto, the absence of a scheme for the systematic revision of plans meant that they were often out of date on account of estate developments, new roads and other changes, and the plans as published remained in that condition for many years. The Ordnance Survey now intends to introduce a system of continuous revision of plans, and survey parties will be retained in certain towns, their duty being to keep up to date information on changes in ground features of the areas allotted to them. Changes will be noted as they occur, but new plans will only be issued when sufficient alteration warrants it, or if they should be specially asked for. In this connection

one of the objects in mind when choosing a smaller size map for the new series was that revision to any one map could be effected more speedily.

As there will be new survey centres at various places it should lead to closer co-operation between the Post Office and the Ordnance Survey at Regional level. It might perhaps be mentioned that already there is very close co-operation between Ordnance Survey Headquarters and the Engineer-in-Chief's office.

#### *Supply of Ordnance Survey Maps.*

The majority of line plan records is drawn on linen maps, but if the records are not required for reproduction, e.g. Area corrosion maps and standard route maps, they are kept on mounted paper maps. The linen maps have the map detail printed in reverse on the underside and are known as True-to-Scale Reverse Linens. The plant detail is drawn on the upper surface and thus amendments can be made without affecting the map outline.

Paper maps are supplied to the Post Office on application to agents appointed by the Ordnance Survey. For linen maps, however, the quality of the maps prepared by the Ordnance Survey from the map plates is far superior to that produced by any other process and, accordingly, special arrangements have been made for obtaining requirements from that source.

The New Popular (Outline) 1 in. map is unsuitable for records in the form in which it is normally issued by the Ordnance Survey, for the reasons already explained. The Post Office desired a map which has no overlap and has its sheet edges coinciding with grid lines. As it was not possible to produce a map specially for Post Office use, the Ordnance Survey undertook to supply mounted paper maps of the outline edition cut and made up to the size of a rectangle, representing a coverage of 60 kilometres by 40 kilometres. The overall dimensions of these sheets are approximately  $38\frac{1}{2}$  in. by 27 in. To obtain prints of these paper maps it is necessary to use the photographic reflex process by which a film of the paper map is made. From this film it is easy to obtain prints on paper or linen as required.

#### *Filing and Use of the New Plans.*

The reduction in the size of the 25 in. plan will necessitate somewhat different filing arrangements from the present, and since there will be from 3 to 4 times the number of plan sheets, additional filing accommodation will be required. The filing of prints of the plans should not cause any difficulty, since by folding they can be accommodated in the standard foolscap filing cabinets, which will be an advantage where maps are required for frequent reference, e.g. in installation controls.

On account of its smallness the new plan may be given a rather mixed reception. Whilst it has advantages in that prints will be more manageable in the field, in the Drawing Office and Development Office the reduced coverage means that more plans will have to be handled, which for a specific scheme may break up an otherwise comprehensive picture of the plant, although a complete layout of a scheme may be

obtained by pasting together prints of the same scale. Due to the necessity for restricting to the essential minimum the area covered by the 50 in. survey, there will be cases where only part of the territory covered by a 25 in. plan will be available at the 50 in. scale. The remaining sections can, however, be enlarged to the 50 in. scale by the Department if it is found to be desirable.

The introduction of the National Grid presents an opportunity for extending the Standard Reference numbering scheme, from an Exchange Area basis, to embrace the whole of a Telephone Manager's Area. Such an index would reduce considerably the total number of linen maps required compared with the Exchange Area numbering scheme, since it entails recording on each linen map the plant in the entire territory covered by the map; this would offset to some extent the increase in the number of maps due to the smaller sheet sizes. This arrangement is already in use in some Telephone Areas and it is considered that it has many advantages. The numbering of the linens on a Telephone Manager's

Area basis would not preclude, however, the filing of prints on an Exchange Area basis.

#### *Acknowledgment.*

Much of the information in this article has been obtained from recent Ordnance Survey publications. The new maps are explained in detail in three booklets published by the Ordnance Survey Office, the booklets being entitled "A Description of Ordnance Survey Small, Medium and Large Scale Maps," respectively. Information on the National Grid is contained in an Ordnance Survey Booklet No. 1/45, entitled "A Brief Description on the National Grid and Reference System," published by the Stationery Office. Use has also been made of the material contained in the "Report of the Davidson Committee," which has formed the basis of negotiations between the Ordnance Survey and the Post Office.

The authors express their thanks to the Ordnance Survey Office for their kind permission to reproduce information from the above publications and for the assistance given with this article.

## Book Review

"Electronic Instruments." Edited by Ivan A. Greenwood, Jr., J. Vance Holdom, Jr., Duncan Macrae, Jr. McGraw-Hill Publishing Co., Ltd., London. 708 pp. 463 ill. 13 pp. index. 54s.

This book is No. 21 of the Radiation Laboratory Series issued by the Massachusetts Institute of Technology. It is the combined product of 19 contributing authors, and is divided—somewhat unexpectedly in view of the title—into five main parts:

1. Electronic Analogue Computers, 212 pp.
2. Instrument Servomechanisms, 274 pp.
3. Voltage and Current Regulators, 77 pp.
4. Pulse Test Equipment, 90 pp.
5. Design and Construction of Electronic Apparatus, 41 pp.

Of these sections, only the fourth would normally be classified under "Electronic Instruments," and the fifth is devoted to practical lay-out considerations and factory problems. Illustrative examples are all culled from the war-time work of the Radiation Laboratory on such problems as air navigation, and thus tend to be somewhat limited in scope. Very often, indeed, the authors use a technical "jargon" and assume a prior knowledge of the problem to be solved, neither of which are likely to be familiar to the uninitiated reader, and as a result he is left feeling most frustrated.

Nevertheless, the book forms a most useful catalogue of circuits and other devices forming the tools of the Electronic Research Engineer, and these elemental circuits are treated in detail in a manner which is usually clear and precise, although, of course, the combined work of 19 authors is bound to show differences in both style and clarity. The approach is usually mathematical, and this will appeal to those whose mathematics are sufficient to stand the strain; the second section in particular illustrates the immense power of the Laplace Transform in the analysis of transient phenomena, but we greatly fear that very few engineers possess the specialised knowledge to enable them to appreciate such esoteric treatment.

The first section of the book deals with analogue

computers—that is to say, computers which utilise a mechanical or electrical device the action of which duplicates the mathematical processes required. Large numbers of such analogue circuits and devices are described, and the section concludes with two examples of computer design—always the best way to terminate a thesis, although the examples in this case appear to be rather specialised, and the practical points somewhat confused with those proper to the theoretical design.

The second and longest section deals with servomechanisms—"Power amplifying devices in which the amplifying element driving the output is actuated by the difference between the input and the output." The great point of such devices is their ability to amplify mechanical power, and to transmit information from one place to another; the combination of these properties enables large powers to be controlled remotely, and that without reaction on the controlling element.

The treatment here is very detailed, with the emphasis laid on stability and overall accuracy, particularly as regards transient phenomena. References are many, and one has the feeling that as far as the authors were concerned, this is the book and the rest incidental. Again, though, there is that mixing of practical and theoretical considerations which interferes with smoothness of flow—the section is less a treatise than a report.

Section 3 is a survey of methods of voltage and current regulation. The performance of circuit elements is discussed in detail and many practical circuits are described. It forms a most useful collection of data on this subject.

Section 4 deals with some circuits employed for pulse working, and then goes on to describe various cathode-ray oscilloscopes using such circuits and developed for radar purposes during the war. The final section, as has been said, is devoted to constructional problems.

This is a good book, particularly for reference purposes, but does tend to be fragmentary. The feeling is there that it has been made a receptacle for everything that did not naturally fit anywhere else.

A. W. M. C.

# Channel Islands Communications

J. RHODES, M.B.E., B.Sc.(Eng.), A.M.I.E.E.

U.D.C. 621.39 (423.4)

In an earlier article<sup>1</sup> a brief account was given of the skeleton communications set up on the liberation of the Channel Islands in 1945. Since that time developments have taken place giving greatly improved communication facilities, and the present article records the work carried out and mentions the future developments contemplated.

## Introduction.

A FURTHER stage in the post-war reconstruction of the communications between England and the Channel Islands was recently completed when the bringing into service of the new repeater station at St. Peter Port, Guernsey enabled a new London-Guernsey and a new Jersey-Guernsey 12-circuit group to be set up.

The submarine cable routes to and between the Islands are shown in Fig. 1. All the submarine cables

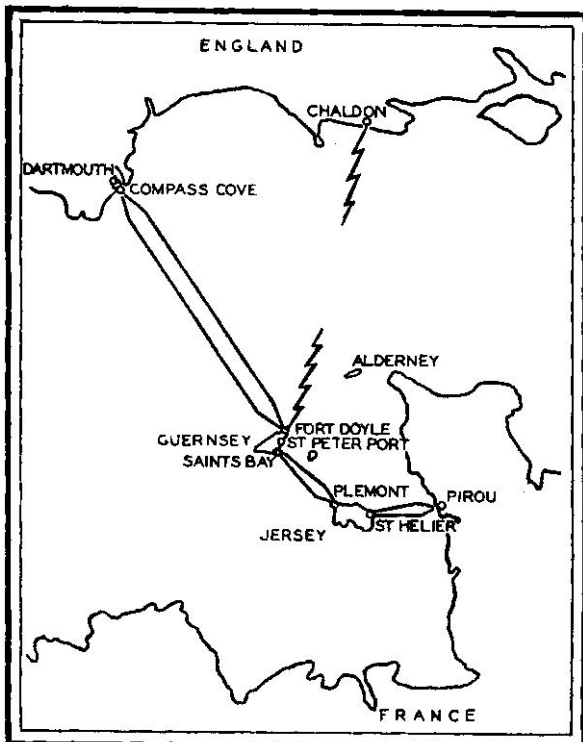

FIG. 1.—SUBMARINE CABLE ROUTES TO CHANNEL ISLANDS.

are of the standard 0.62-in. paragutta insulated coaxial type. The first cable on each route was laid in 1938, and the second cable was laid in 1940 in connection with a scheme to provide a second route to France as an alternative to the Dover-Calais route. However, only part of this latter scheme was brought into service before the occupation of France in May, 1940 brought an end to this route.

The coastal repeater station for the route in this country is situated at Dartmouth and from there to Compass Cove, which is the submarine cable landing point, there is a 4-pair balanced pair cable of special construction. The two submarine cables then run from Compass Cove to land at Fort Doyle, in Guernsey; a length of approximately 67 nautical miles. A repeater station is situated at Fort Doyle and the submarine cables are then extended across Guernsey

to St. Peter Port, the main town, and then to Saints Bay, which is the landing point of the inter-Island submarine cables. These two submarine cables are each approximately 17 nautical miles long and are laid between Saints Bay and Plemont, the landing point on Jersey, and from this point they are extended on balanced pair cable to St. Helier, the main town of Jersey.

## RESTORATION AND DEVELOPMENT OF COMMUNICATIONS

When the Islands were liberated in 1945 it was necessary to provide telephone and telegraph services as quickly as possible. The following account details the preliminary arrangements made and the subsequent developments which have taken place.

### Telegraph Communications.

The need for telegraph communications with the mainland was met by the urgent installation, on a temporary basis, of 6-channel M.C.V.F. equipment of portable type in the Head Post Offices in Jersey and Guernsey. This enabled a 6-channel system to be set up between London and Jersey and another between Jersey and Guernsey.

The equipment employed at the London terminal was of similar type to that installed in the Islands and had been previously installed during the war years for military requirements.

At a later date the V.F. equipment at Jersey and Guernsey was removed from the H.P.O.s to the repeater stations in the Islands, and the London system was rearranged to work to Guernsey instead of Jersey.

To cater for the anticipated expansion in the number of public telegraph circuits required to the mainland, on account of the introduction of automatic teleprinter switching, and also to provide private wire services between the Islands and to the mainland, it was decided to replace the portable type of equipment by permanent installations using standard P.O. 18-channel Type 3 equipment.

The permanent installations cater for an 18-channel system between London and Jersey; a 12-channel system between London and Guernsey and a 6-channel system between Guernsey and Jersey. The first stage of this conversion programme was completed in March, 1947, when the permanent M.C.V.F. terminal was opened in St. Helier repeater station. This installation comprises one 18-channel and one 6-channel V.F. equipment of standard (Type 3) design, with associated generator and test bays, and teleprinter test and monitor sets for both private wires and public circuits. The L.T. and H.T. supplies for these systems are obtained from the repeater station power plant, while the 80 + 80 volt supplies for

<sup>1</sup> P.O.E.E.J. Vol. 38, p. 102.

signalling and running the multi-frequency generator are obtained from a double battery float power plant using constant potential rectifiers of the Westat type.

An installation of a similar nature is in course of provision in the new repeater station in Guernsey and will probably be brought into service about the end of 1949. Meantime the Channel Islands telegraph services consist of the following systems:—

- London-Jersey, 18 channels.
- London-Guernsey, 6 channels (portable equipment).
- Jersey-Guernsey, 6 channels (portable equipment).

*Telephone Communications.*

The temporary arrangements made on the liberation of the Islands were as follows:—

- (a) Dartmouth-St. Helier (Jersey), 1 + 3 Carrier System.
- (b) Dartmouth-Guernsey, 1 + 3 Carrier System.
- (c) Jersey-Guernsey, 1 + 4 Carrier System.

On (a) and (c) the audio channel was used to carry the 6-channel telegraph systems referred to previously.

Although the telephone circuits were quickly established and worked quite satisfactorily they have now been replaced by modern systems giving 12-circuit groups between London-Jersey, London-Guernsey and Jersey-Guernsey respectively, i.e. 24 cable circuits to the Islands and 12 inter-Island circuits. The arrangement of the systems is shown in Fig. 2, in which it will be seen that they form a triangle and so provide a measure of alternative routing in order that one Island will not be completely isolated in the event of a failure of any one submarine cable. It will also be seen from Fig. 2 that at Dartmouth the

12-circuit systems to the mainland are routed directly into the British 12-channel network and have their terminal in London, a feature which is now becoming quite common on many submarine cable systems.

The three submarine cable systems are generally similar to each other in that they carry 12 circuits and occupy the same frequency range. They are group worked (i.e. the Go and Return channels are carried on the same single coaxial cable). The Go channels occupy the frequency range 12 to 60 kc/s and the Return channels the frequency range 72 to 120 kc/s.

A simplified block diagram indicating the circuit arrangements at Dartmouth is shown in Fig. 3. It will be seen from this diagram that in the Go direction the 12-channel group from London, in the frequency range 12 to 60 kc/s, is pre-equalised and amplified at Dartmouth and then passed through directional filters to the balanced pair cable without any frequency change. At Compass Cove, line filters are provided to separate the audio transmission band, 0 to 10 kc/s, from the main carrier transmission band, 12 to 120 kc/s. This is to allow for the provision of the music circuit as described later. From this point, the transmit group passes over the submarine cable to Fort Doyle, where it is amplified and then passed to the balanced pair cable across Guernsey and over the inter-island submarine cable to Jersey, where it is finally demodulated at St. Helier. In the Return direction at St. Helier the group is first modulated into the frequency range 12 to 60 kc/s and is then subject to further modulation with a carrier frequency of 132 kc/s, thus translating it into the frequency range 72 to 120 kc/s. It is transmitted in this frequency range over the submarine cables and across Guernsey to Dartmouth where it is separated from the Go group by directional filters and, after passing through special equalisers and high gain amplifiers, it is translated into the frequency range 12 to 60 kc/s for feeding into the British 12-channel network for transmission to London.

Between Fort Doyle and Dartmouth the total attenuation between the two coastal repeater stations at 120 kc/s is 109 db. This very high attenuation has

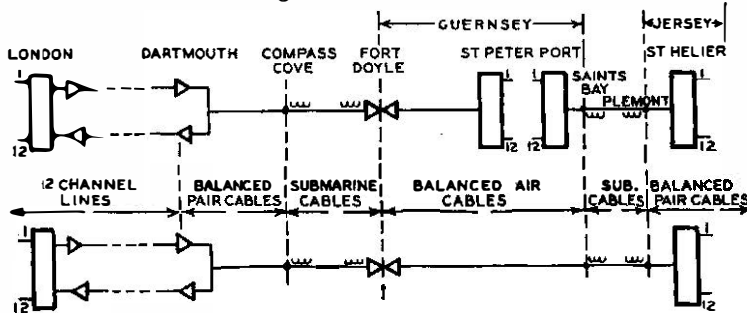

FIG. 2.—ARRANGEMENT OF 12-CHANNEL GROUPS.

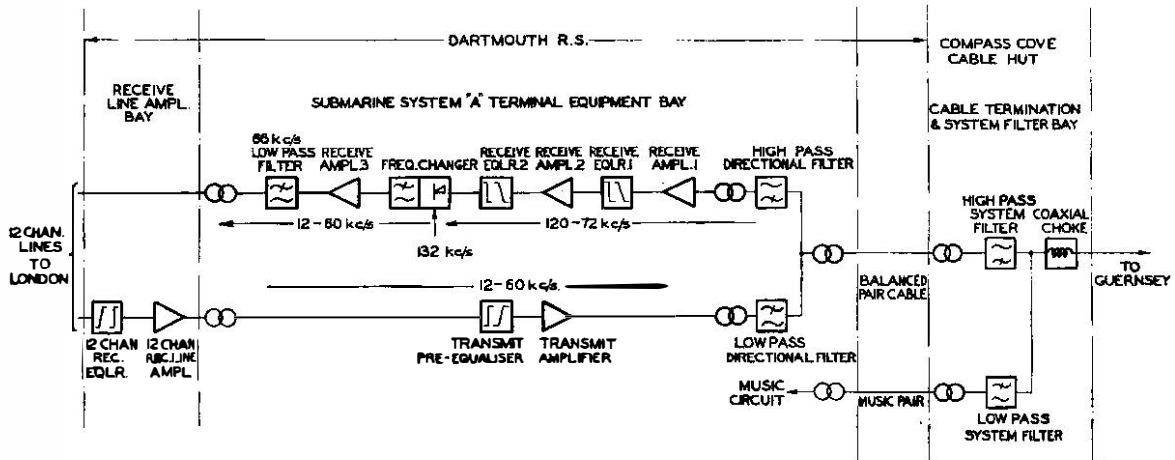

FIG. 3.—SCHEMATIC DIAGRAM OF CIRCUIT ARRANGEMENTS AT DARTMOUTH REPEATER STATION.

required the use of high power transmitting amplifiers at Fort Doyle and even then the incoming level at Dartmouth is of the order of  $-87$  db. on the highest channel, in the frequency range 116 to 120 kc/s. This channel is, therefore, slightly below the normal British standards for basic resistance noise, but is within the international limit and it has not, therefore, been thought necessary to go to the additional complication of the provision of companders to improve this signal-to-noise ratio. The overall of all the circuits has been made 3 db. and, with this overall and the high velocity routing throughout, echo suppressors are not necessary on any of the circuits.

The Channel Islands are favourite places for outside broadcasts by the B.B.C. and opportunity was taken when the new scheme was planned to provide a good quality music circuit from either Island to the mainland. From St. Helier to Plemont and from Saints Bay to Fort Doyle the music circuit is routed on 40-lb unloaded pairs, but on each of the submarine cable links it is transmitted in the frequency band 0 to 10 kc/s, below the frequency band occupied by the speech system. The audio band of the second submarine cable in each link is used for a 2-wire amplified speaker circuit. This speaker circuit is therefore independent of the 12-channel systems.

From Jersey there are two submarine cables to Pirou on the Cherbourg peninsula. These cables were, of course, laid for the alternative route to France mentioned earlier. One has recently been repaired and a direct circuit from St. Helier to Renne in Brittany has been provided. There has always been a strong community of interest between the Islands and the adjacent French coast, and before the circuit was provided, calls had to be routed via the round-about way of London and Paris.

#### Radio Link.

To re-establish the radio link which had existed before the war, it was decided to provide a 6-channel,

frequency modulated system with transportable equipment. Each station was to be completely self-contained in two vehicles with trailer-type engine-alternator power units and transportable aerial systems, as it was necessary to establish communication as soon as possible after the landing. A block schematic of the equipment is shown in Fig. 4. Radio frequencies in the band 45-53 Mc/s were allocated and it was estimated that, with a transmitter power of 100 W, a maximum frequency deviation of  $\pm 300$  kc/s, a modulation depth per channel of 20 per cent. (equivalent to  $\pm 60$  kc/s deviation) and employing a total aerial gain of some 30 db., it would be possible to establish circuits with a signal-to-noise ratio of about 55 db. except under extreme fading conditions.

Rhombic aerials, mains power supply and landlines were provided in advance at the old site near Chaldon, Dorset (see Fig. 1). The mobile equipment was constructed and fully tested under field conditions and held in readiness to move at a few hours' notice.

After the Liberation the mobile station was set up on Guernsey and 6 channels extended to London. The mobile equipment remained until the beginning of this year when it was transferred from the vehicles to permanent buildings.

A single channel V.H.F. radio-telephone link was provided in April between Guernsey and Alderney as a temporary measure and a 6-channel circuit is now being installed.

#### Acknowledgments.

The author acknowledges with thanks information supplied to him by members of the Radio and Telegraph Branches of the Engineer-in-Chief's Office and used in sections of this article. It is also desired to draw attention to the valuable services rendered by staff of the South-Western Region during the restoration and development of communication services to the Islands.

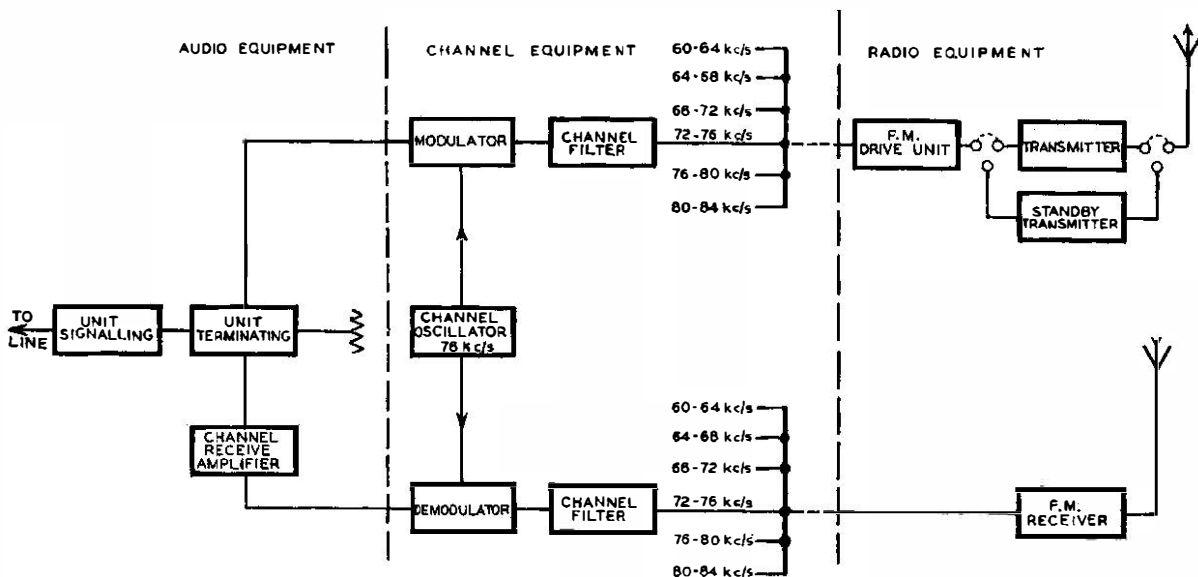

FIG. 4.—SCHEMATIC DIAGRAM OF 6-CHANNEL F.M. RADIO EQUIPMENT.

# The Wire Rope Traction Drive

R. S. PHILLIPS, M.I.E.E.

## Part 2.—Constructional Details and Factors affecting Operation

U.D.C. 621.876 : 621.853

The second and concluding part of this article gives details of the construction of typical wire ropes used for traction drives and summarises the static and kinetic rope stresses experienced. Various other factors to be considered in ensuring the safe and economical operation of such drives are also discussed.

### Rope Construction.

THE rope used has several strands, each comprising a number of steel wires twisted together. The strands are twisted around a lubricated fibre core to form the rope. Many different combinations of number and size of wires and strands are employed and both wires and strands may be twisted clockwise or anti-clockwise. When the wires in the strand and the strands are twisted in the same direction the result is a Lang lay rope and this may be right or left handed according to the direction of twist. In an Ordinary lay rope the wires and the strands are twisted in opposite directions. The Lang lay is more flexible than the Ordinary lay and resists abrasion better as it presents a larger surface to the grooves. It is difficult to handle, however, because it immediately untwists when cut.

The wires used are of tensile strength between 80 and 120 tons per sq. in., although for very flexible ropes, steel of tensile strength less than 80 tons per sq. in. is sometimes employed. These wire tensile strengths are considerably higher than the tensile strength of the steel from which the wire is made and are obtained by cold drawing or a combination of drawing and heat treatment. The range between about 40 and 80 tons per sq. in. is considered by wire manufacturers to be treacherous and unreliable in its properties and for this reason, B.S.329 does not recommend any wire of tensile strength less than 80/90 tons per sq. in.

The wires of the strand are usually all of the same

diameter but in the Seale rope the wires of the outer layer are of larger diameter than the remainder. These larger wires resist abrasion better than smaller wires but result in a stiffer rope. The outer layer of wires in a Warrington rope is composed of wires of alternately large and small diameters and is a compromise between the uniform and Seale constructions. A flattened-strand rope or an oval-strand rope is sometimes adopted with the object of presenting a still greater wire surface to the groove and they are popular for mining purposes. In some constructions the centre of each strand is composed of a fibre core, but usually the strand centre is a single wire.

The strands are twisted around a fibre core, and for lifts the number of strands is usually either six or eight, the latter resulting in the more flexible rope, but the wire size for the same rope circumference must be smaller and hence it does not resist abrasion as well as the six-stranded rope.

Ropes with fibre-centred strands are usually six-stranded, each strand being either one layer of 12 wires (6/12) or 24 wires laid 15 around 9 (6/24). These ropes are very flexible, but the proportion of fibre to wire is high and the breaking strength is necessarily low. Other popular six solid-stranded ropes are 6/19 uniform (12 round 6 round 1), 6/19 Seale (9 round 9 round 1) and 6/37 (18 round 12 round 6 round 1). Some of these constructions are shown in Fig. 8. The 6/19 uniform-wire rope is probably the most common and it is considered sound policy to use

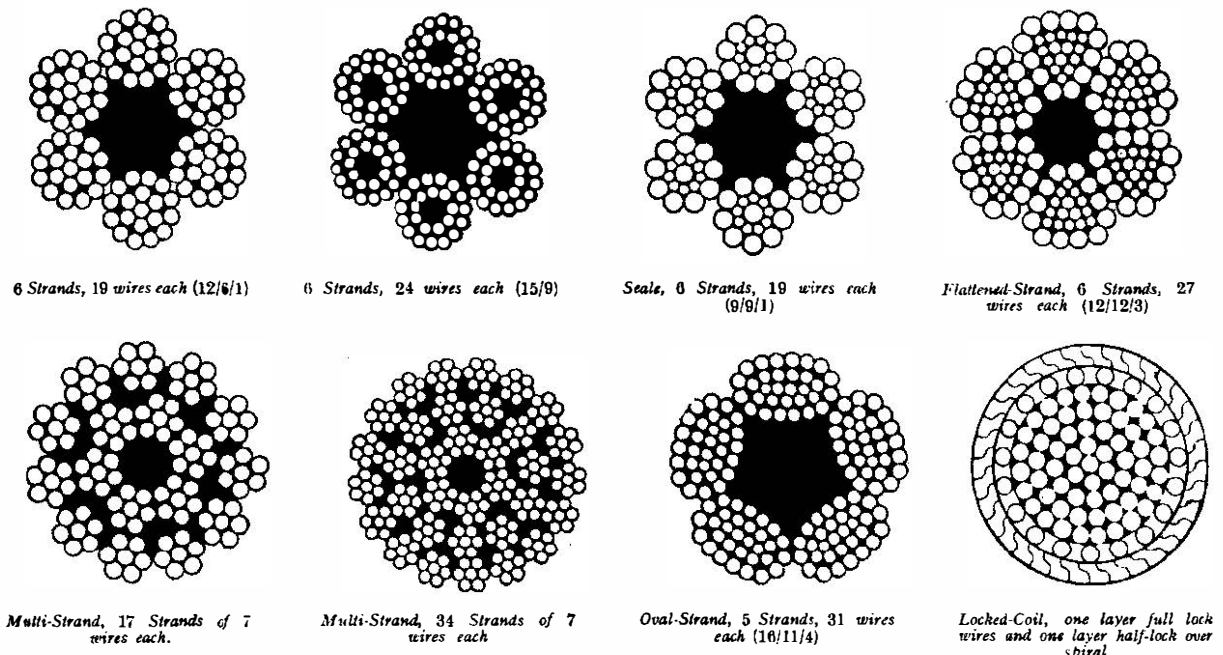

FIG. 8.—TYPICAL ROPE CONSTRUCTIONS.

this rope when in doubt as to the best construction to adopt for a particular purpose. The 8/19 uniform, Seale and Warrington are favoured by some users when flexible ropes are required.

The main types of ropes used for mine winding engines are the six-strand (round or flattened), the non-rotating multi-strand (17 or 34 strands) or the locked-coil rope which has an outer covering of interlocking wires to prevent displacement of the inner wires.

In a pre-formed rope the wires of the strands and the strands are formed during manufacture to their exact final shapes. The internal rope stresses are therefore eliminated, and when cut the rope is "dead" and does not untwist. Wires broken during service retain their positions in the strand and are difficult to detect but do not cause damage to adjacent wires or to the sheave. The life of a 6/19 pre-formed rope has been found to be greater than that of a corresponding normal 6/19 rope particularly with small sheaves and pulleys<sup>6</sup>.

The more common sizes of lift ropes are between 1 in. and 2½ in. in circumference and the diameters of the wires range between 0.021 in. and 0.052 in., respectively, for the uniform 6/19 construction. Mining ropes may be up to 6 in. in circumference and in a few mines are as much as 10 in.

#### Lubrication.

The effect of lubrication on the outer wires of the rope and the sheave groove was dealt with under "Coefficient of friction." The presence of a lubricant lowers the value of the coefficient of friction and hence decreases the value of  $T_1/T_2$  at slipping. It is, therefore, desirable that the grooves and the outer wires be as dry as is practicable.

When a rope is subjected to bending by passing over a sheave or pulley, relative motion takes place between adjacent wires and between the strands, and the presence of lubricant inside the rope facilitates this movement by decreasing the internal friction. Internal lubricant also retards corrosion of the wires and preserves the core, as a dry centre quickly deteriorates and collapses with resulting nicking of the wires. Practical experience indicates that the life of the rope is impaired through insufficient lubricant, whilst laboratory tests<sup>5</sup> have shown that unlubricated ropes gave 40 per cent. of the life given by well-oiled ropes. Some of the Wire Ropes Research Committee tests<sup>4</sup>, however, gave results that tended to contradict the above and are difficult to explain. Except for severe bending on small sheaves the dry ropes which were tested gave a larger number of bends before failure than did the lubricated ropes. This has caused considerable discussion and the only possible explanation has been advanced by Scoble who suggested that the lubricant may act as a carrier of abrasive particles worn from the wires and sheaves. There is, however, considerable evidence to support the view that internal lubrication is beneficial in increasing the flexibility and life of the rope.

The desired conditions, therefore, are a dry exterior and an interior oiled with suitable lubricant, but these are difficult to retain during use.

#### Stresses in the Rope.

The total stress in the rope is made up of a number of individual stresses due to various causes, some direct and others indirect. They are summarised and described below:—

(a) *Static stress.* This is caused by the load and the weight of the rope and is

$$W + wl$$

where  $W$  is the load,  $w$  the weight per unit length of the rope and  $l$  the length of the rope.

This stress is greatest near the sheave and when the load is at its lowest position.

(b) *Kinetic stress.* This is due to accelerating and retarding the load. The maximum value of this stress is  $Wf/g$ , where  $f$  is the maximum acceleration or retardation and  $g$  the acceleration due to gravity. It is important to note that the portion of the rope near the load is subjected to all the accelerating and retarding stresses and must be expected to deteriorate more rapidly than other parts, which are protected from such stresses by the elasticity of the rope. For the same reason a short rope is more heavily stressed by kinetic shocks than a long rope. In this connection the Regulations relating to Safety in Mines<sup>7</sup> state that every winding rope shall be recapped at intervals of not more than six months, and before recapping a length of at least 6 ft. shall be cut off the rope. The object of this is to alter the positions of those parts of the rope which are subject to the most severe deterioration, particularly at the capel and the part that passes over the sheave. It also provides a specimen from which the condition of the rope can be ascertained.

(c) *Bending stress.* This is the stress set up in the rope due to its bending to conform to the sheave groove. It is important because its magnitude is appreciable and may even exceed that due to the load. The problem of determining this stress is very complex as it depends upon a number of variables. The chief of these are the size of the wire used, the diameter and condition of the sheave, the lengths of the lays of the strand and of the rope, and indirectly the condition of the core and its lubricant. The construction of the rope also affects the bending stresses set up, as the stress in a single wire of the rope is greater the farther the wire is from the axis of the rope and the nearer it runs parallel to this axis. In an Ordinary lay this combination of conditions exists but it does not in a Lang lay because where the wires lie parallel to the rope axis they are nearest the axis of the rope and are embedded in the core. For this reason the bending stresses in a Lang lay rope may be taken as approximately 80 per cent. of those of Ordinary lay rope<sup>5</sup>.

Static tests were made by Skillman<sup>8</sup> on ropes of ⅝ in., ¾ in., ⅞ in., 1 in. and 1¼ in. diameter in direct tension and in tension around sheaves of 10 in., 14 in. and 18 in. diameter. The steel was of 115 tons per sq. in. tensile strength. He found that the strength on sheaves was less than that on straight ropes, the ratio being 0.87 for ⅝ in. ropes on 10 in. sheaves and 0.95 for ⅞ in. ropes on 18 in. sheaves. For 1¼ in. ropes the corresponding values were 0.76 and 0.85.

The bending stress,  $f$ , in a single-wire bent to an arc of a circle is quoted in text books as

$$f = E\delta/D$$

<sup>6</sup>For references see end of article.

where  $E$  is the modulus of elasticity of the material,  $d$  the diameter of the wire and  $D$  the diameter of the sheave around which the wire is bent.

This cannot be strictly correct, however, and as shown by the following practical consideration the actual stress must be less than is given by this formula. If a steel wire of 0.07 in. diameter and of tensile strength 80/90 tons per sq. in., for which the value of  $E$  may be taken as 13,000 tons per sq. in., is bent around an 8 in. diameter sheave, the bending stress from this formula will be 110 tons per sq. in., and the wire would break.

Because of the twisting of the wires to form the strand and of the strands in the formation of the rope, the actual bending stress in the rope is smaller than that in a single wire. Many experimenters have assessed values for  $E_R$  in the formula

$$f_R = E_R d / D$$

where  $f_R$  is the bending stress in the rope and  $E_R$  the coefficient of elasticity of the rope.

It is often stated that for a 6/19 rope  $E_R = 0.44E$ , where  $E$  is the coefficient of elasticity of the material. As a result of tests on a large number of ropes, Howe<sup>9</sup> gave values for  $E_R$  of  $12.8 \times 10^6$ ,  $11.4 \times 10^6$ ,  $10.4 \times 10^6$ ,  $10 \times 10^6$  lb. per sq. in. for 6/7, 6/19, 6/37 and 8/19 ropes respectively. Griffiths<sup>10</sup> carried out tests on various types of 6/19 ropes and found that  $E_R$  varied between  $6.3 \times 10^6$  and  $8.9 \times 10^6$  lb. per sq. in. The formula is reasonably correct, however, only when the stresses in the steel are kept within the limits of proportionality. This limit is reached when the stress is approximately 50 per cent. of the breaking stress. If the total stresses exceed this figure, plastic flow in the steel takes place and results in permanent deformation.

Other formulæ have been deduced for calculating the rope bending stress and one given by Chapman states that it is

$$(Ed \cos^2 \alpha \cos^2 \beta) / D$$

where  $\alpha$  is the angular pitch of the strand wires and  $\beta$  the angular pitch of the strands in the rope.

Hardesty<sup>11</sup> contended, however, that the bending stress is

$$(Ed \cos \alpha \cos \beta) / D.$$

Howe<sup>9</sup> developed formulæ for calculating the bending stress in a rope of any construction in terms of the wire and strand sizes and lays.

Most experiments seem to confirm that for six-stranded ropes a value for  $E_R$  of  $12 \times 10^6$  lb. per sq. in. is reasonable for estimating purposes and that the actual value is probably somewhat lower. Moore's tests<sup>12</sup> indicate that there is a big difference between values of  $E_R$  for different size ropes of the same construction and that for small ropes less than  $\frac{3}{8}$  in. diameter the value was greater than  $12 \times 10^6$  lb. per sq. in.

The stress set up due to bending is considerable and to keep the value low the sheaves and pulleys should be as large as practicable. The bending of the rope in the reverse direction should be avoided when possible as it results in a shorter life or alternatively for the same life the working tension will be about  $\frac{3}{4}$  that for bends all in the same direction<sup>6</sup>.

(d) *Centrifugal stress.* When the rope passes round the sheave it is subjected to centrifugal action which results in tensile stress in the rope due to the centrifugal force. If  $f_1$  is the stress in the rope in lb. per sq. in. due to centrifugal force,  $w_1$  lb. is the weight of a cubic in. of the rope and  $v_1$  the rope speed in ft. per sec.

$$\text{then, } f_1 = \frac{12w_1 v_1^2}{g} = \frac{w_2 v_1^2}{g}$$

where  $w_2$  is the weight in lb. of 1 ft. of the rope of 1 sq. in. sectional area.

The tension in the rope due to centrifugal action is, therefore,  $f_1 a$  lb. where  $a$  is the sectional area of the rope in sq. in. This is not of sufficient magnitude to be of practical importance.

(e) *Frictional stress.* The force required to overcome the friction between the car and its guides results in an additional stress in the ropes. In lifts the guides are usually of steel whilst mining shafts are fitted with steel, wood or wire rope guides. When the car or counterweight is travelling upwards this frictional resistance causes an increase in the car or counterweight rope stress, but in the downward direction the friction causes a decrease in the rope stress.

(f) *Windage.* In a similar manner to friction, the wind pressure causes an increase in the rope stress in the upward direction and a decrease when travelling downwards. The values of these resistances depend upon the speed of travel and the sectional areas of the car and counterweight.

(g) *Unbalanced stresses.* In addition to the stresses caused by the load, motion and bending there are other stresses in the wires which are created during rope construction. These are evident when a Lang lay rope is cut and the stresses are released as the rope unwinds. Such stresses are negligible in a pre-formed rope in which the wires and strands are formed to their final shape during manufacture. A pre-formed rope when cut is "dead" and when an individual wire breaks during service it retains its position in the strand. The total stresses are therefore smaller than in the usual type of rope. A pre-formed rope may, therefore, be expected to give longer life and this has been proved in practice.

Laboratory tests on the steel wires of a rope have shown that if the wires are subjected to stresses which exceed about 25 per cent. of their ultimate tensile strength, fatigue is induced in the steel. If the stresses are kept within this fatigue limit they can be imposed many millions of times without failure of the wires. In a similar manner the limiting fatigue stress of about 25 per cent. of the breaking stress applies to the rope as well as to individual wires. The sum of all the stresses in the rope, as enumerated above, must be kept well below this fatigue limit and the ratio between the breaking strength and the total working stresses is a measure of the real factor of safety of the rope.

#### *Sheave or Pulley Diameter.*

The simplest roping system, shown in Fig. 1, requires that the sheave diameter be equal to the distance between the car and counterweight ropes and this is always arranged when possible.



When the rope passes over the sheave or pulley, there is relative movement between the strands, and as the sheave diameter is decreased, there is a critical diameter below which the strands cannot slide further and strand motion becomes restricted. To obtain reasonable rope life it is necessary to use an economical minimum sheave diameter greater than this critical diameter. The more flexible the rope construction, the smaller is the critical diameter and hence also the economical minimum diameter. It has also been noted that the bending stress is inversely proportional to the sheave diameter, and in order to reduce the value of the stress the sheave should be as large as practicable. This is illustrated by tests<sup>5</sup> carried out with 6/19 ropes on a sheave of critical diameter, sixteen times the rope diameter. When this critical sheave diameter ( $16d$ ) was increased by 50 per cent. to  $24d$ , the life of the rope was found to be approximately 500 per cent. greater than that obtained with a critical diameter sheave. By increasing the  $24d$  sheave by 50 per cent. to  $36d$ , the life was 70 per cent. greater than with the  $24d$  sheave. This seems to indicate that the bending stress may not vary directly as the sheave diameter as is generally supposed but that the graph showing the relation between the two may be a curve.

B.S.329 recommends that the minimum ratio of sheave or pulley diameter to rope diameter for lifts and hoists should be 41 for 6/12 and fibre, 6/19 and 6/24 constructions and 47 for 6/19 Seale. Post Office lifts generally use 6/19 uniform Lang lay rope and the minimum sheave or pulley diameter adopted is 55 times the rope diameter. The generally accepted minimum sheave-to-rope ratio for main shaft mining drives is 100 to 1, but where man-riding is forbidden lower ratios are used.

#### *Lap of the Rope.*

For many years it was thought that the bending of a rope through a small angle, i.e., a small angle of lap on the sheave or pulley did not cause such severe bending stress as if the angle of lap were large. This has, however, been proved to be incorrect and except for very small angles of lap the number of bends before failure varies very little with the amount of lap on the pulley. A lap of  $20^\circ$  was found to have the maximum bending effect, which was equal to that with a lap of  $90^\circ$ . In the tests<sup>13</sup> the lay of the rope subtended an angle of  $31^\circ$  on the pulley. The endurance varied little until the lap of the rope was reduced to nearly half the lay of the rope, below which the number of bends before failure increased greatly.

#### *Effect of Speed.*

As the rope speed increases, the stress due to centrifugal force also increases and this tends to cause the rope to leave the groove, and decrease the angle of wrap, although these effects are not of practical importance.

Experience indicates that the destructive effect on a rope is greater if the speed of travel is increased, but the reason for this is not clear. It might be supposed that the number of bends before failure would be less if the rapidity of bending were increased, i.e., the rope speed increased, but actual rope bending tests tend to

contradict this theory<sup>13</sup>. It has been suggested that the reason for this is that at high speeds, the time between the bending and re-bending of the rope is insufficient to allow complete disarrangement of the wires.

It is quite likely that the cause of shorter rope life at high speeds is not associated with bending but is due to the fact that higher accelerations and consequently higher kinetic stresses usually occur with higher speeds. In addition, these kinetic stresses often result in greater slip between the rope and sheave during the acceleration and retardation periods, which is accompanied by more wear on the outside wires.

To compensate for the shorter rope life at higher speeds, B.S.329 states that for each increase in speed of 100 ft. per minute above 400 ft. per minute, the diameter of the sheave should be increased by 2.5 per cent. This of course, is a convenient method of compensating for the greater destructive effect at higher speed, but it would perhaps be more logical to increase the rope factor of safety with an increase of speed, providing the sheave and pulleys are of adequate sizes.

#### *Factor of Safety.*

The factor of safety for ropes is quoted in B.S.329 as the ratio of the guaranteed breaking strength to the maximum "dead" working load and a minimum value of 12 is specified for lifts and hoists providing the specified sheave and pulley sizes are used. The use of this factor of safety is misleading as it does not represent the true margin of safety of the rope which should be the ratio of the breaking strength to the sum of all the ascertainable rope stresses. The latter include the acceleration and bending stresses which are frequently larger than the stress due to the "dead" load. It is usual to assume the maximum tension in the rope as equal to the weight of the car, plus maximum load and to multiply this by 12 to arrive at the minimum breaking load of the ropes, from which the number and size are calculated. It must be borne in mind, however, that the number of ropes required may be even more than this in order to secure a large enough value of  $T_1/T_2$  for adequate traction.

Another interesting fact is that an increase in rope size, in an endeavour to increase the factor of safety, may not always result in a larger value of the true factor of safety defined above. When the sheave diameter is small, the bending stress is high and the direct tensile strength relatively low, and in these circumstances the use of a larger rope increases the bending stress more than it reduces the tensile stress.

#### ● QUOTED REFERENCES.

- <sup>1</sup> R. S. Phillips, "Electric Lifts," Pitman's, 1948.
- <sup>2</sup> D. A. Low, "Applied Mechanics," Longman's.
- <sup>3</sup> David Lindquist, "Modern Electric Elevators," *Transactions of American Society of Mechanical Engineers*, 1915, page 705.
- <sup>4</sup> "Fifth Report of the Wire Ropes Research Committee," *Institution of Mechanical Engineers' Journal*, 1935, page 373.
- <sup>5</sup> C. D. Meals, "Bending Stresses in Wire Ropes," *Transactions of American Society of Mechanical Engineers*, 1929, Vol. 51, MH-51-5.
- <sup>6</sup> "Third Report of Wire Ropes Research Committee," *Institution of Mechanical Engineers' Journal*, 1928, page 353.

<sup>7</sup> "The Examination of Colliery Ropes in Service," H.M. Stationery Office, London, 1937.

<sup>8</sup> E. Skillman, "Some Tests of Steel Wire Ropes on Sheaves," U.S. Bureau of Standards, *Technologic Paper* No. 229, 1923.

<sup>9</sup> James F. Howe, "Determination of Stresses in Wire Ropes as Applied to Modern Engineering Problems," *Mechanical Engineering*, Vol. 40, 1918, page 1043.

<sup>10</sup> Griffiths and Bragg, "Strength and Other Properties of Wire Rope," U.S. Bureau of Standards, *Technologic Paper* No. 121, 1919.

<sup>11</sup> S. Hardesty, "Stresses in Wire Rope," *Mechanical Engineering*, Vol. 41, 1919, page 257.

<sup>12</sup> R. R. Moore, "A Study of the Elastic Properties of Small Size Wire Cable," *Transactions of American Society of Mechanical Engineers*, 1921, page 767.

<sup>13</sup> "Fourth Report of the Wire Ropes Research Committee," *Institution of Mechanical Engineers' Journal*, 1930, page 553.

#### OTHER REFERENCES.

"First Report of Wire Ropes Research Committee," *Institution of Mechanical Engineers' Journal*, 1920, page 835.

A. J. Dixon, "Power Transmission by Wire Rope," *Power*, 1921, Vol. 53, page 893.

"Second Report of the Wire Ropes Research Committee," *Institution of Mechanical Engineers' Journal*, 1924, page 1193.

C. A. Armstrong, "Methods of Rope Drive on Electric Elevator Machines," *Power*, 3rd February, 1925.

H. B. Cook, "Loading of Elevator Cables and Bearings," *Power*, 31st March, 1925.

C. C. Clymer, "Some Factors in Roping Traction Elevators," *General Electric Review*, November, 1927.

H. W. Swift, "Power Transmission by Belts," *Institution of Mechanical Engineers' Journal*, Vol. 2, 1928.

A. J. Morgan, "Proper Wire Rope Lubrication," *Power*, 1933, Vol. 77, page 430.

"Which Wire Rope for Elevators?," *Power*, May, 1939.

J. J. P. Dolan and W. G. Jackson, "An Investigation into the Permissible Load Carrying Capacity of Steel Wire Ropes for Hoisting with Special Reference to Deep Level Winding on the Witwatersrand Gold Field," *Institution of Mechanical Engineers' Journal*, Vol. 142, 1939.

A. J. Morgan, "How to Detect and Cure Wire Rope Troubles," *Power*, January, 1941.

"Elevator Wire Rope Maintenance," *Mechanical Engineering*, February, 1943.

W. I. Lex, "How to Choose the Proper Wire Rope Construction," *Power*, August, 1948.

H. Hitchen, "Deep Shaft Winding Problems," *Mechanical World*, March 18th-April 8th, 1949.

## Book Reviews

"The Elements of Electromagnetic Waves." L. A. Ware. Pitman Publishing Corporation. 203 pp. 69 ill. 20s.

There is an increasing need for telecommunications engineers to study not only circuit and transmission line theory, but also general electromagnetic wave theory, and this book, based on lectures to electrical engineers, has been written to help meet this need.

Although the book is intended to be elementary the author rightly employs vector analysis, but no previous knowledge of this is assumed. In dealing with the addition and subtraction of vectors, the author could, perhaps, have stressed more the conception of a vector as a directed magnitude which can be represented by a rectilinear displacement from one point to another in space.

Following the discussion of vector operators, scalar and vector potentials are introduced, and their application to static electric and magnetic fields. In this part of the book the author does not always make it clear where the laws apply only to static fields and where they apply both to static and dynamic fields. Somewhat sketchy proofs of Gauss's and Stokes's theorems are given and the vector forms of Maxwell's equations are then derived from the line integral forms with the aid of Stokes's theorem. It is assumed that the reader is already acquainted with the line integral forms and their experimental foundation. The book cannot, therefore, be regarded as a complete introduction to electromagnetic theory, but rather as an introduction to the vector form of Maxwell's equations and their application in electromagnetic wave problems. Provided the student fully appreciates this limitation, it may not matter. For the engineer and physicist, rather than the mathematician, it is probably best to study electromagnetic theory along the lines of its historical development, rather than to take Maxwell's equations as the fundamental starting point.

The discussion of plane waves and their reflection provides a good introduction to the impedance of the medium and waves in conductors, and leads naturally to the study of waves between parallel plates and in rectangular guides.

The last chapter is devoted to the study of the dynamic potentials and their application to the determination of the radiation field of simple aerial systems. There are mistakes in the expressions for the potential F.

The now generally preferred rationalised M.K.S. system is used. The book is well reproduced with a set of problems at the end of each chapter. Within the limitations mentioned the book can be recommended as a sound introduction to the subject of electromagnetic waves.

R. F. J. J.

"Power Capacitors." R. E. Marbury. McGraw-Hill Publishing Co., Ltd., London, 1949. 205 pp. 122 ill. 21s.

This book deals with the large capacitors used in connection with electricity mains supplies and distribution systems and covers the history of development, manufacture and employment, as seen from the American standpoint. It does not cover the use of capacitors used for radio interference suppression on mains-connected appliances, or for power factor correction of gas discharge lighting circuits.

On the aspects covered there is abundant and authoritative technical information, but some further discussion on the extent to which it is economical to correct a consumer's power factor and a warning on the effect of series capacitors used for line reactance compensation on the prospective short-circuit current would have been welcomed.

The book is well got up and reasonably free from misprints, but there are certain passages which, if differently worded, might be clearer. The concept of a capacitor supplying reactive kVAr is not likely to be acceptable to readers of this Journal, but this method of presentation may result from an endeavour to make the book as the publishers say, "Readily understood by both Engineers and those who have little technical background."

An extensive bibliography is given.

S. I. B.

# Phonogram Automatic Distribution

H. E. WILCOCKSON, A.M.I.E.E.,  
and H. WALKER

## Part I.—Field Trial Installation and General Facilities

U.D.C. 621.395.341.8 : 621.394

A new type of phonogram equipment, developed within the Post Office, has been installed at Newcastle-on-Tyne and successfully opened for service on the 12th June, 1949. A description is given of this field trial installation and of the facilities provided by the equipment, prefaced by a brief historical survey. Part 2 will describe the basic circuit elements employed in the queueing, storage and distribution of the incoming calls and other elements, including those which provide for the automatic control of the queue size according to the number of available staffed positions.

### Introduction.

THE scheme to be described provides for the automatic chronological distribution of incoming phonogram and telephone-telegram (T.T.) calls in cyclic order to free staffed operators' positions and will, it is thought, be of general interest, having in mind the current trend towards the use of cordless type switchboards. The primary objective of the scheme is the elimination of the "unfortunate" call which is subjected to a time of answer well above average (a condition which is inherent in present forms of lamp signalling ancilliaried switchboards), but the use of automatic equipment in place of plugs, cords and multiple jack-field also enables the phonogram operators to enjoy the more congenial working conditions provided by cordless type operating positions.

A number of novel features have been incorporated in the field trial equipment, the relative values of which will emerge during the course of the field trial, thus enabling the facilities required as standard for subsequent installations to be determined in the light of practical experience.

A general view of the phonogram switchroom at Newcastle equipped with standard double-tier ancillary switchboards as it existed in January 1949, just prior to modification, is given in Fig. 1. A corresponding view of the same operators' positions after modification

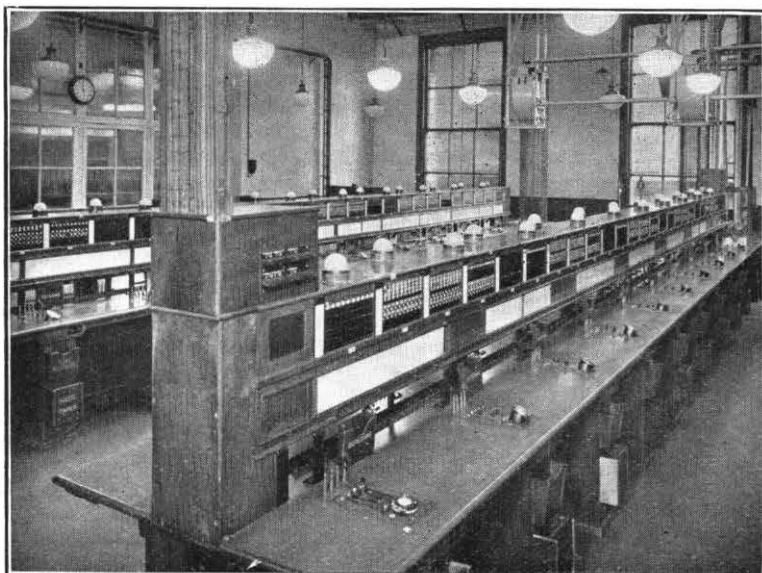

FIG. 1.—THE PHONOGRAM SWITCHROOM AT NEWCASTLE, EQUIPPED WITH DOUBLE-TIER ANCILLIARY SWITCHBOARDS.

for use with the automatic distribution equipment is given in Fig. 2.

The initial experience gained with the operation of the equipment indicates that the reaction of the operating staff is favourable, and that in addition to eliminating the "unfortunate" call, the improved operating facilities should enable the reduction in the average time of answer to be maintained.

### Historical Survey.

The question of the suitability of some form of automatic distribution system for phonogram working, as an alternative to the previous systems of distributing calls—from a manual concentrator or by means of an ancilliaried switchboard—was examined by a Headquarters committee set up in 1928 to consider the type of equipment to be installed in the phonogram office at the Central Telegraph Office (C.T.O.), London. After exhaustive investigation and examination of all known phonogram systems in this and other countries, a report was issued in 1932 recommending the installation of the ancilliaried switchboard system<sup>1</sup> which had been for some time the standard at a few large provincial phonogram offices in this country.

The answering of calling signals in the order in which they originate cannot be assured on an ancillary switchboard, particularly in phonogram rooms, where the operators are unable to keep the calling signals under observation during the writing down or dictation of messages. It is inevitable, therefore, that during pressure periods a certain percentage of calls suffer a time of answer well above the average.

A "Delayed Call Flashing" facility<sup>2</sup> is fitted as a standard arrangement on phonogram ancillary switchboards and provides for the flashing of the lamps of calling circuits not answered within a certain period, usually 15 to 30 seconds, and to which priority is given by the operators. The "unfortunate" call is not, however, entirely eliminated with this facility, as several calls may be flashing simultaneously.

To overcome this undesirable feature consideration was given at a later date to an automatic queueing scheme for delayed-answer calls as an adjunct to the

<sup>1</sup>P.O.E.E.J., Vol. 30, p. 26.

<sup>2</sup>P.O.E.E.J., Vol. 26, p. 7.

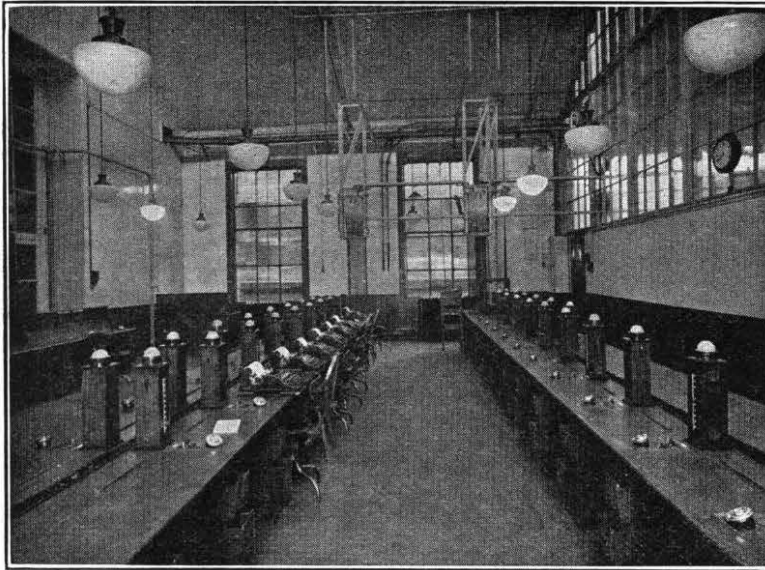

FIG. 2.—NEWCASTLE PHONOGRAM SWITCHROOM AFTER MODIFICATION FOR USE WITH AUTOMATIC DISTRIBUTION EQUIPMENT.

ancillary switchboard system. In this scheme calls were normally to be answered in the ancillary field, but should the calling signal remain unanswered after a pre-determined period, say 10 to 15 seconds, the automatic call queueing equipment operated to connect the call to the queue storage equipment. The calling lamp in the ancillary field remained glowing while at the same time a queue pilot lamp, associated with a queue answering jack, was caused to glow on each position. Priority was to be given to the queue. The insertion of a position answering cord into the position queue answering jack by any operator caused the connection of the first waiting call to the particular operator concerned. The calling lamp in the ancillary field, also the pilot lamp of the answering position, ceased to glow. If other delayed-answer calls were connected to the queue storage equipment, the queue pilot lamps of the positions not connected to a call in the queue remained glowing. When all calls in the queue storage equipment had been answered and discharged, the position queue lamps ceased to glow and calls would then be answered in the normal ancillary field.

A disadvantage of the scheme, unless an excessive provision of equipment additional to the normal ancillary switchboard equipment was to result, was that when the queue storage equipment was occupied to its full capacity, further calls waiting to enter the queue storage equipment did so on a chance basis. Hence, under conditions of heavy delay, when the benefits of the proposed scheme were most needed, the queueing facility for delayed calls was inoperative. The development of the scheme was finally abandoned at the outbreak of war.

In 1943, consideration was again given to the type of equipment to be installed at C.T.●, London, this time to replace the temporary manual concentrator system which had been installed in refuge accommodation when the standard ancillary equipment was

destroyed in December 1940. The question of the automatic distribution of traffic was again raised, but it was decided that the equipment to be installed in the new accommodation at C.T.O., London, should be similar to that in the refuge accommodation, i.e., manual concentrator. It was appreciated, however, that the standard ancillary system was not wholly satisfactory in practice, especially in regard to the speed of answer during busy periods, when calling subscribers may experience inordinate delay in obtaining a reply. For this reason, and because the equipment of the standard ancillary system had become obsolescent and would, in any case, require modernisation for future installations, it was decided that an experiment in the automatic distribution of phonogram traffic was justified as soon as circumstances would permit. The basic facilities to be provided for such a scheme were given further consideration

at a Phonogram Conference held in March 1945, after which active development work was commenced and Newcastle phonogram office was selected for the field trial.

#### GENERAL FACILITIES

The automatic queueing and distribution equipment has been designed to eliminate the "unfortunate" call which is inherent in the present standard phonogram ancillary switchboard system and also the manual concentrator system.

Fig. 3 shows in block schematic form the items of equipment providing the call queueing and automatic distribution facilities, as well as the complementary services for outgoing calls, transfer of calls, etc.

Facilities are provided whereby effects of sudden peaks of traffic are smoothed out by automatically increasing the number of staffed positions to which incoming calls have access, with the possibility of still further increasing the availability of staffed positions by means of a master key under the control of the Chief Supervisor, should the peak be sustained.

Provision is made for the automatic distribution of incoming calls to free staffed positions on a cyclic basis, and for the calls to be connected direct to an operator's headset without the manipulation of keys on the part of the operator. When a free position is not available, calls are queued in the order of arrival and are distributed in that order to positions as they become free. Busy tone is returned to calls arriving at the installation when all available queue positions are occupied.

The range of operating positions is divided into three separate groups, i.e., incoming positions, bothway positions and outgoing positions. The positions are, however, universal and may be included in any of the three separate groups by the strapping of a single tag on a terminal strip, situated on the position apparatus rack, to the appropriate group.

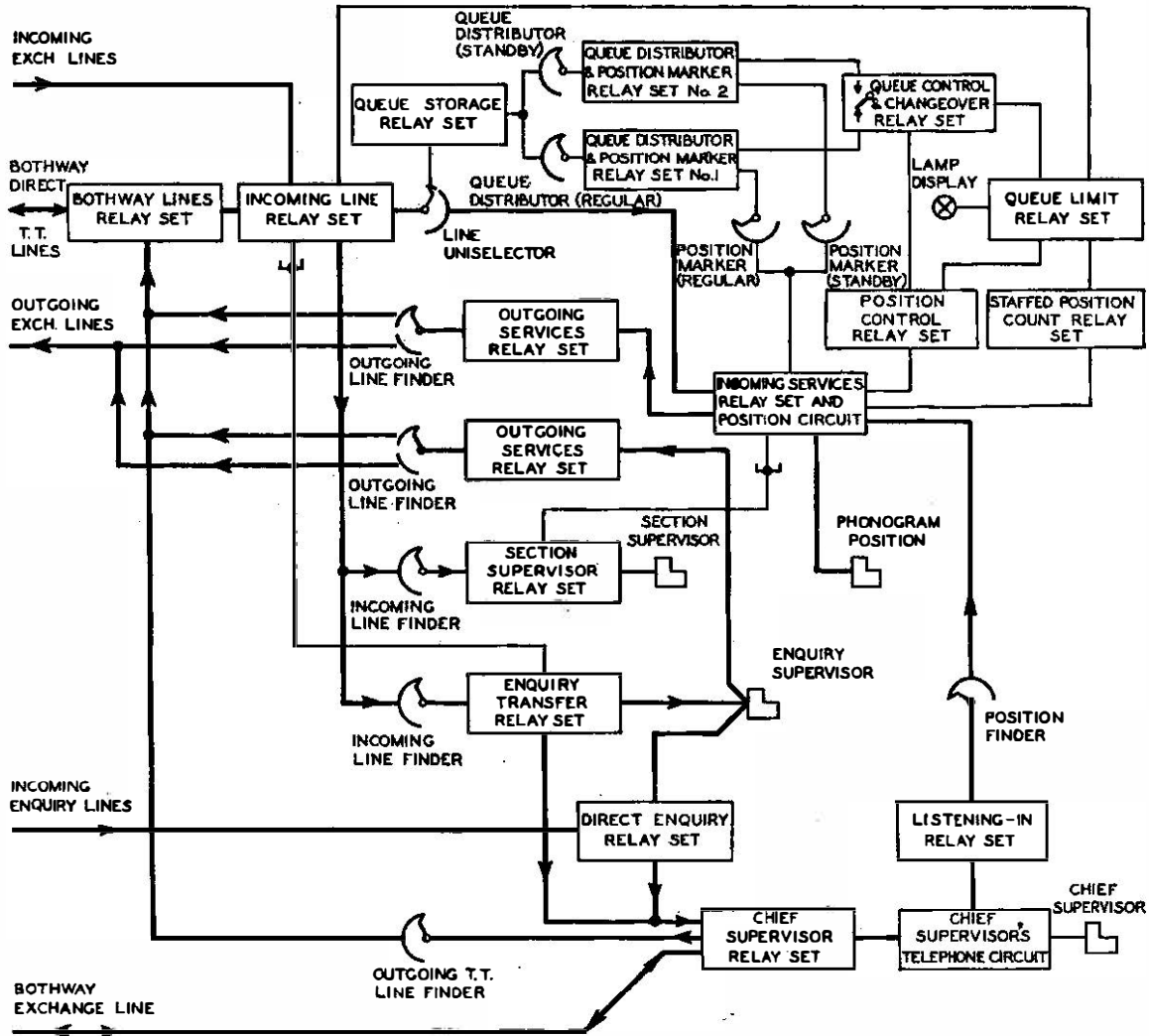

FIG. 3.—BLOCK SCHEMATIC DIAGRAM OF CALL QUEUING AND AUTOMATIC DISTRIBUTION EQUIPMENT.

Incoming calls are presented in the order of arrival to free staffed incoming positions in cyclic order. The bothway positions normally function as outgoing positions, but should all the available incoming positions be engaged and an incoming call be waiting connection, this call is automatically routed to a free bothway position. To meet seasonal traffic or sustained peaks of traffic, all the bothway positions may, at the discretion of the Supervisor, be converted to incoming positions by the operation of a master key. This key, when operated, includes the bothway positions in the cyclic distribution of calls, and calls are presented in due order to free bothway positions, whether or not a free incoming position is available. Following the operation of the master key, individual outgoing positions may also be converted to incoming positions at the discretion of the Supervisor, by the operation of keys provided on the basis of one per outgoing position. Thus all positions may be made available to incoming traffic, if desired.

#### Queue Control.

The number of queue positions available at any

time may be decreased or increased, up to a maximum of 15 positions, according to the number of staffed positions available to incoming traffic. This variation may be carried out manually by the Supervisor, or automatically. In the manual operation the setting of a rotary type switch determines the limit of the queue positions, whereas, for automatic operation, the removal, or insertion, of an operator's headset from the position jack causes a counting device to function. At the conclusion of the counting operation the number of queue positions is automatically limited in accordance with the staffed positions available to incoming traffic. The ratio of queue positions is pre-set, but may be altered from time to time, should the necessity arise, by means of straps on a terminal strip.

#### Lamp Display.

A queue lamp display, easily visible by the phonogram operators, is provided as part of the operator's desk equipment. This display, which is situated between each pair of operators and functions only when all available staffed incoming positions are engaged, gives individual indication of the state of the

first five queue positions and a common lamp for "Over 5" positions. In addition, a "Queue Full" lamp glows when the limit of the queue is reached.

The Chief Supervisor is also provided with a queue lamp display, but in this display individual indication is given for the maximum queue together with an audible alarm whenever the "Queue Full" lamp glows. Independently of the queue lamp display, provision is also made for the number of staffed incoming positions to be indicated automatically to the Chief Supervisor by means of lamps.

#### *Position Lamps.*

A dome-shaped opal cover containing a green and a red lamp is accommodated on each position. These lamps, which glow only when a position is engaged on an incoming call or an outgoing call respectively, facilitate the supervision of the operators by the Section Supervisor and also enable the officer distributing messages for outward transmission quickly to locate a disengaged position.

The green lamp glows steadily whenever the staffed position is engaged on an incoming call. If, however, the operator fails to operate the position release key within 15 seconds after the clear down of the calling subscriber, in order to free the position for the receipt of a further incoming call, the green lamp changes from a steady glow to a flashing signal.

The red lamp glows whenever a position is engaged on an outgoing call.

#### *Transferred Calls.*

Incoming calls to the phonogram operators may be transferred to either the Enquiry positions or the Section Supervisor by operation of the appropriate transfer key on the operator's position. In each instance the phonogram operator may be released from the transferred call and therefore free to accept further incoming calls, by the operation of a "Release" key at the Enquiry or the Section Supervisor's position. Calls transferred to the Enquiry positions may be further extended, if required, to the Chief Supervisor.

#### *Forced Release Calls.*

Calls may be "Forced Released" from an operator's position only by transferring the particular call to the Section Supervisor and the operation by the Section Supervisor of a Forced Release key fitted on her position. The call is then cleared from the operator's position and the Section Supervisor's equipment, and the line relay set concerned holds to the calling or fault condition. An audible and visual alarm is given if the line relay set holds to the calling condition beyond a predetermined period. It will be appreciated that incoming calls to an operator's position can only be released from that position by the clear-down of the calling party or by transfer from the operator's position to either the Enquiry position or the Section Supervisor.

#### *Common Equipment.*

Automatic change-over to standby equipment is provided should the regular common control equip-

ment fail to function correctly. The standby equipment is positioned to agree with that of the regular common control equipment upon taking over. Manual change-over is also provided for maintenance and test purposes.

#### *Outgoing Services.*

Outgoing calls may be originated from any position over the exchange network or to direct telegraph-telegram (T.T.) circuits by the operation of the appropriate outgoing key on the position, which also busies the position to the receipt of incoming calls. The operation of the position "Exchange" outgoing key causes a uniselector associated with the position to hunt over a common group of exchange lines for a free outlet. Busy tone is returned should all outlets be engaged. Direct T.T. circuits are obtained by the operation of the position "Direct T.T." outgoing key and the dialling of a pre-arranged code. Standard tones, indicating the condition of the called line, are given. A common 8-level uniselector is used for both outgoing services. The operation of the particular outgoing key selects the levels of the position uniselector to be brought into service.

#### EQUIPMENT AND INSTALLATION ARRANGEMENTS

The field trial equipment provides for 75 incoming line circuits, a total of 35 operators' positions (these being arranged, initially, to function as 10 incoming, 15 bothway and 10 outgoing positions), and for a maximum of 15 calls to be held in queue storage positions under peak traffic conditions. Provision for two Enquiry positions, three Section Supervisor's positions, one Chief Supervisor's desk and one remote listening-in position, all with key-ended circuit terminations, has also been made.

To avoid any extensive modifications to the existing conveyor belt and pneumatic tube systems, such as would have been necessary had the automatic distribution equipment been sited in new accommodation, it was decided that the field trial equipment should be located in the same accommodation as that occupied by the ancillary switchboard equipment. It was also decided that the revised requirements for the operating positions should be met by modification of the existing desks, thus avoiding the delay which would have been incurred by the design and manufacture of new desk equipment.

Fig. 4 shows the floor layout plan for the field trial equipment. In the Phonogram Room the recovery of the ancillary switchboards, position wiring and cabling, and the subsequent modification and rewiring of the desks was carried out by the local engineering staff who also undertook the recovery from the apparatus room of the apparatus racks associated with the ancillary switchboards. The subsequent installation and cabling of the four 10 ft. 6 in. by 4 ft. 6 in. 2000-type apparatus racks (Fig. 5) required for the mounting of the automatic distribution equipment was carried out by Ericssons Telephones Ltd., who were also responsible for the manufacture of all the automatic equipment required for the field trial.

To enable the phonogram and T.T. services to be maintained during the rearrangements, a manual

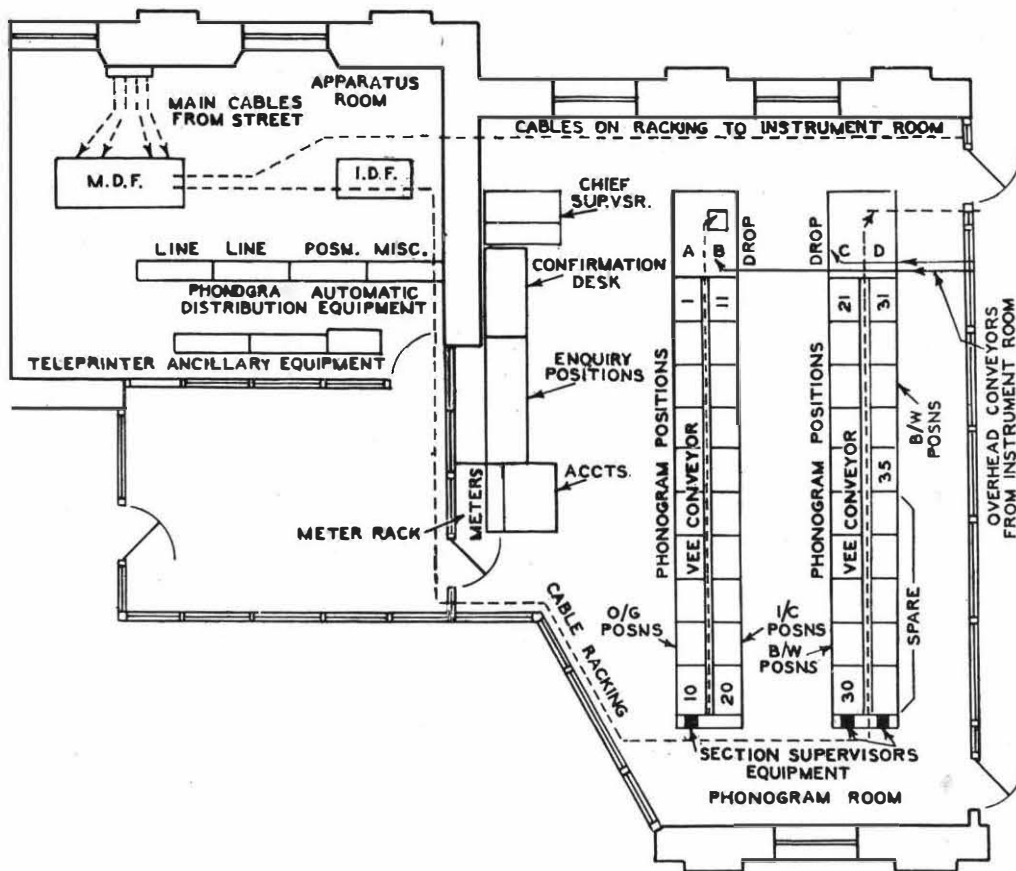

FIG. 4.—FLOOR PLAN OF FIELD TRIAL EQUIPMENT AT NEWCASTLE.

concentrator system, consisting of one concentrator (switchboard) position and 30 operators' positions, was installed by the local engineering staff in temporary accommodation.

The use of automatic switching equipment for the

distribution of calls, in place of plugs, cords and jacks, naturally involves the provision of additional rack-mounted equipment, but allowance should be made for the fact that with ancillary switchboard equipment the position relays were mounted under the desks, whereas with the automatic distribution equipment all the relay equipment is rack-mounted.

The rack-mounted equipment employs standard components as used in automatic telephone practice and, in consequence, requires a 50V power supply. Ringing tone and busy tone, not previously connected at phonogram installations, are also required for the automatic distribution equipment.

To meet these requirements the existing 22V power equipment was moved to temporary accommodation thus permitting the installation of two 50V batteries, each of 200 Ah capacity, motor generators, power panel, ringers, etc. in the permanent accommodation. The 50V power plant is arranged for divided battery float operation, and is connected by cable to the standard 50V busbar distribution arrangements on the 2000-type apparatus racks.

(To be continued).

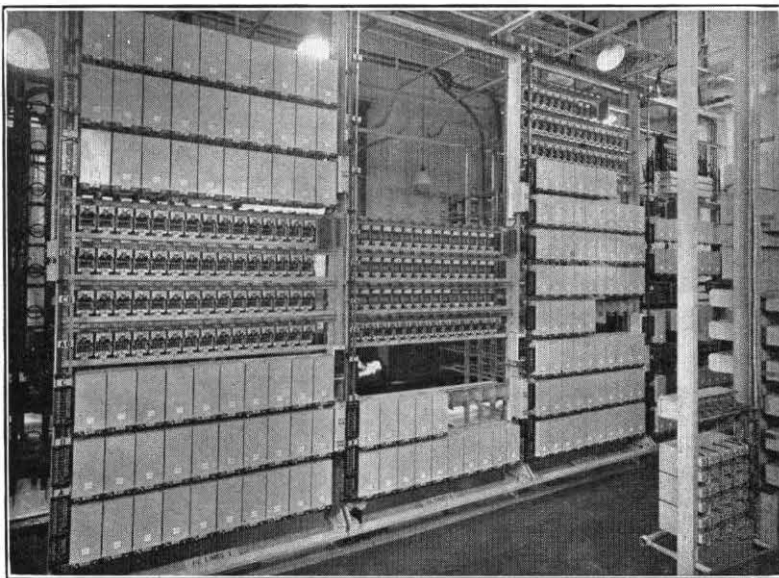

FIG. 5.—FRONT VIEW OF RACKS EQUIPPED WITH AUTOMATIC DISTRIBUTION EQUIPMENT.

# Sectionalisation of Telephone Repairs

U.D.C. 621.395.61.004.67

C. E. LAFOSSE  
(Factories Department)

**Heavy demands made on the Post Office Factories during the war, combined with shortage of skilled operatives, led to the introduction of mass production methods adapted to the repair of telephones. The author describes the scheme evolved and results achieved.**

## *Introduction.*

MASS production, as practised in modern industry, has become so commonplace that its application arouses little interest other than curiosity in the labour-saving devices employed. It has, however, been almost solely confined to construction or assembly of products for which a continuous flow has been guaranteed.

It was, therefore, very much in the nature of an innovation that in the Autumn of 1942 the Post Office Factories Department after agreement with the P.O. Engineering Union, decided to adapt mass production methods to the repair of telephones, and formed production units to develop this scheme which was termed "Sectionalisation." This was so named because the production method separated skilled telephone mechanics' repair work into equal sections for female dilutees, allowing a modified form of mass production methods. To a certain extent the venture was made necessary by the influx of dilutee female labour recruited to meet:—

1. The demands made upon the factory to carry out an extensive programme of construction of special telecommunication equipment for the armed services.
2. The increased output requirements of repaired telephone apparatus due to the wartime curtailment of the telephone manufacturers' production.
3. To offset the effects of mobilisation of skilled male operatives.

The adoption of the sectionalisation scheme released male operatives with the requisite skill needed for the production of the air defence apparatus, mobile army equipment, short-wave radio and carrier equipment constructed in the factory.

## *Accommodation and Layout.*

Operation of the scheme was made possible by the acquisition of part of a modern factory at Bull Lane, Edmonton, which provided the accommodation suitable for adaptation to the required layout. The area of space for the scheme was approximately 6,500 sq. ft. measuring 90 ft. long by 72 ft. wide. This was divided into two repair shops leaving a central portion 90 ft. by 10 ft. for the Engineering Department's Test and Inspection Branch staff and for completed work.

Benches of four work positions were arranged five feet apart at right angles to the central portion. Benches and chairs were designed to allow operatives to sit or stand in comfortable working positions. Test positions were situated in the central portion adjacent to each work bench.

Wooden racks, separated from the work benches by five-foot gangways, lined the outer sides of each shop, providing suitable storage space for replacement parts and work for each operative.

The replacement parts were stored in wooden interlocking component trays, contents being indicated by means of coloured discs on the outside of each tray in accordance with a master key exhibited on a control board in a prominent position in the shop.

This design of layout reduced the length of the factory repair circuit to a minimum, and all unnecessary handling was avoided by the method of repair, to be described later, which combined transport with progress of repair.

To assist the economic handling of telephones within the factory, interlocking wooden transport trays, designed to hold ten telephones, provided a safe and easy method of transportation and facilitated the count of the telephones.

Telephones were packed into empty trays in the old stores section for feeding work into the repair shops and through the various stages of repair to the central test positions where, after approval, the telephones were transported to the dispatch room for packing; the empty trays were then returned to the adjoining old stores section.

This completed the general layout designed to meet the needs for repair or assembly of all types of telephones.

## *Production Method.*

The normal mass production method of one operation for each operative could not be applied to the varying types of telephones likely to be repaired in the factory, for the fluctuating degrees of urgency for each type, representing many short runs, would have involved frequent changes of set-up and consequent loss of production.

Each type of telephone provided a varying proportion of skilled work calling for the experience of a telephone mechanic. It was therefore decided to form complete production units, composed of one telephone mechanic and three women dilutees, capable of dealing with long and short runs of varying work and conforming to the general theory of standardisation for the scheme. Fig. 1 shows two production units with a test position in the foreground.

## *Processes of Production.*

Owing to the varying types of telephones repaired, it is not possible, nor is it considered necessary, to give details of each process here. A general outline describing the standard pattern will suffice.

The work was first performed in correct sequence of repair and divided into four processes according to the time taken. If, after trial, the processes varied due to changing conditions of repair, corrective adjustments were applied. The shop foreman was responsible for the division of the processes and proposing a piece-work price for each. The work generally conformed to the following pattern:—





FIG. 1.—TWO PRODUCTION UNITS WITH A TEST POSITION IN THE FOREGROUND.

- Process 1. Test components and dismantle as necessary.
- Process 2. Clean and repair.
- Process 3. Refit missing parts.
- Process 4. Adjust and test.

Each production unit occupied one bench of four positions. The female operatives performed processes 1, 2 and 3 respectively and the telephone mechanic, occupying the position adjacent to the test position, performed the 4th and final process.

Subsidiary operations such as polishing mouldings and fitting bases after test were performed by female dilutees as separate jobs and dealt with in bulk.

Process 4 was generally decided by the amount of skilled work on the job, which consisted mainly of checking the work already completed, adjusting and testing before passing to the Engineering Department test position for approval.

All component parts that could be cleaned or repaired on the job were dealt with in process 2. Those beyond repair or needing plating, enamelling, polishing, etc., were placed by the operative in wooden chutes attached to the bench, for feeding the parts into their respective trays underneath the bench for collection and treatment in bulk.

#### *Incentive.*

All operatives worked on a piece-work basis ; each process performed by the female operatives carried the same piece-work price, and those by the telephone mechanic an appropriate piece-work price in accordance with his higher hourly rate, with possible additional work. In keeping with factory practice, for certain types of work submitted for test, a premium bonus based on the relative piece-work price was paid to all the members of each unit whose work was approved at first presentation—an incentive which yielded good quality work with speedy production.

#### *Training.*

To determine the most suitable process for each new entrant, training was given on all three processes by four skilled telephone mechanics who had been trained in "Job Instruction" under the Ministry of Labour "Training Within Industry" scheme which has been adopted generally in the London Factory. It was also their responsibility to give operatives help when necessary, to ensure that jigs and fixtures were maintained in good order and correctly used, and to act in the capacity of "trouble shooters." Training timetables were maintained by two shop foremen. Each of these foremen controlled 12 production units, and it was their responsibility to allocate work to the most suitable labour and correctly place operatives in each production unit. The success of their efforts was reflected in the earnings of the entire shop, and also in the few changes of

staff during the 4½ years' occupation of the Bull Lane premises. During this time 120 female dilutees were recruited to set up and maintain the two shops at the full strength of 72 women. The whole of the staff recruited were new to this type of work ; several were between the ages of 55 and 65 and many had domestic ties. Despite this and the effects of wartime strain the few staff changes involved tend to show with what satisfaction the scheme was received.

#### *Conclusion.*

The telephone sectionalisation scheme, constituting approximately 10 per cent. of London Factory activity, is considered small in comparison with the mass production methods employed by large manufacturers, but the fluctuating demands from the Supplies Department and the varying supply of old telephones for repair, together with the concurrent repair and assembly of all types of other Rate Book apparatus, called for something entirely different from conventional standards. It is for this reason that the Factories Department among its various activities can reflect with satisfaction on its achievement during the 4½ years ending March, 1947, when 400,000 telephones of various types, 120,000 Bell Sets and a vast quantity of all types of repaired telephone apparatus were delivered to the Supplies Department from the Bull Lane Factory.

Since the removal from Bull Lane to Perivale, sectionalised shops have been operating on a diminishing scale owing to the reducing numbers of old telephones for repair, but the experience gained will undoubtedly be of value if greater demands be made on the factory in the future.

Meanwhile these notes will serve the dual purpose of describing briefly a small section of the contribution of the Factories Department during a difficult period and of paying tribute to all those responsible for the success of that contribution.

# Non-Linear Inductance and Capacitance as Modulators for Amplitude-Modulation Systems

D. G. TUCKER, D.Sc., A.M.I.E.E.

U.D.C. 621.396.619.2

Theoretical considerations of the performance of modulators utilising the non-linear characteristics of suitable inductors and capacitors are discussed, and it is shown that one disadvantage of such modulators is that the output of any sideband depends on its frequency, and that low-frequency products have a small amplitude. Some practical circuits and measured results are given for a magnetic modulator (i.e. using non-linear inductance).

## Introduction.

APPLICATIONS of non-linear inductance are well known, e.g. magnetic harmonic generators<sup>1</sup> and magnetic amplifiers.<sup>2</sup> Applications of non-linear capacitance are not well known. This is because iron-cored inductors are always non-linear and can easily be saturated, thus giving a large range of inductance, whereas capacitors are usually more or less linear with applied voltage. However, non-linear dielectrics are available now—barium titanate<sup>3</sup> being the best known—so that applications of non-linear capacitance may be expected.

An interesting application of both non-linear reactances is to amplitude-modulation. The reactance can be varied by one frequency applied at large amplitude, thus modulating any other frequency applied to it. The capacitance modulator<sup>4</sup> is useful for detection or frequency-changing at very high frequencies (e.g. microwaves) while the magnetic or inductance modulator<sup>5</sup> offers possible advantages at low frequencies, say, up to 100 kc/s. The frequency limitation is imposed by the difficulty of making a sufficiently large capacitance for convenient circuit arrangements at low frequencies, and the impracticability of making saturable inductors at high frequencies. The advantage of the capacitance modulator is that it is likely to be reliable at frequencies where it is difficult to use reliable rectifiers. The main advantage of the magnetic modulator is that it is likely to be more stable than rectifiers or valves.

The theoretical basis of the modulators is given in the next section; this is then followed by a practical discussion of the magnetic modulator.

## OUTLINE OF THEORY

It will be assumed that only simple circuits are used, where the non-linear reactance is controlled (or "switched") by a local tone and is connected in shunt or in series with a generator (i.e. the input signal) and load. It is quite evident that two extreme cases exist:—

- (a) constant-current generator, the output signal being the voltage across the reactor,
- (b) constant-voltage generator (i.e. zero-impedance), the output signal being obtained from the current through the reactor.

All practical cases give results intermediate between these two, and as only these two cases are easily analysed, the following theory will be restricted to them.

<sup>1</sup> For references see end of article.

## Constant-current Generator.

### (i) Inductance modulator.

Let  $i(t) = I \sin qt$  be the signal current. Let  $p$  be the angular frequency of the local tone. Then the inductance is a function of time

$$L(t) = L_0 + L \sum_{n=1}^{\infty} a_n \sin npt \dots \dots \dots (1)$$

The representation by a Fourier series of this incomplete type is justified if hysteresis is ignored.

Now the voltage across the inductance due to the signal current is

$$\begin{aligned} v(t) &= \frac{d}{dt} [L(t) \cdot i(t)] = i(t) \cdot \frac{dL(t)}{dt} + L(t) \cdot \frac{di(t)}{dt} \quad (2) \\ &= I \sin qt \cdot pL \sum_{n=1}^{\infty} na_n \cos npt + \\ &\quad + Iq \cos qt \cdot \left[ L_0 + L \sum_{n=1}^{\infty} a_n \sin npt \right] \dots (3) \end{aligned}$$

We are generally concerned only with the terms of frequency  $p \pm q$ . These are

$$\begin{aligned} &Ia_1 L (p \sin qt \cos pt + q \cos qt \sin pt) \\ &= \frac{1}{2} Ia_1 L [(p+q) \sin (p+q)t - (p-q) \sin (p-q)t] \quad (4) \end{aligned}$$

### (ii) Capacitance Modulator.

Let the capacitance be represented by  $C(t)$ . In any capacitance, voltage = charge/capacitance

$$\therefore v(t) = \frac{1}{C(t)} \int i(t) dt \dots \dots \dots (5)$$

Here it is convenient to represent  $1/C(t)$  as a Fourier series:—

$$\frac{1}{C(t)} = \frac{1}{C_0'} + \frac{1}{C'} \sum_{n=1}^{\infty} b_n \sin npt \dots \dots \dots (6)$$

$$\text{So, } v(t) = \frac{I}{q} \cos qt \cdot \left[ \frac{1}{C_0'} + \frac{1}{C'} \sum_{n=1}^{\infty} b_n \sin npt \right] \dots (7)$$

The terms in  $p \pm q$  are

$$\begin{aligned} &\frac{Ib_1}{qC'} \cos qt \sin pt \\ &= \frac{Ib_1}{2qC'} \left[ \sin (p+q)t + \sin (p-q)t \right] \dots \dots (8) \end{aligned}$$

## Constant-voltage generator.

### (i) Inductance modulator.

$$\text{From (2), } i(t) = \frac{1}{L(t)} \int v(t) dt \dots \dots \dots (9)$$

and in this case,  $v(t) = E \sin qt$ , say.

$$\text{Putting, } \frac{1}{L(t)} = \frac{1}{L_0} + \frac{1}{L'} \sum_{n=1}^{\infty} c_n \sin npt \dots \dots (10)$$

$$\text{then, } i(t) = \frac{E}{q} \cos qt \cdot \left[ \frac{1}{L_0} + \frac{1}{L'} \sum_{n=1}^{\infty} c_n \sin npt \right] \dots (11)$$

and the terms in  $p \pm q$  are

$$\frac{Ec_1}{2qL'} \left[ \sin (p + q)t + \sin (p - q)t \right] \dots \dots (12)$$

(ii) *Capacitance modulator.*

$$\begin{aligned} \text{From (5), } i(t) &= \frac{d}{dt} [C(t) \cdot v(t)] \\ &= v(t) \cdot \frac{\partial C(t)}{\partial t} + C(t) \cdot \frac{\partial v(t)}{\partial t} \dots (13) \end{aligned}$$

$$\text{This time put, } C(t) = C_0 + C \sum_{n=1}^{\infty} d_n \sin npt \dots (14)$$

$$\begin{aligned} \text{so that, } i(t) &= E \sin qt \cdot pC \sum_{n=1}^{\infty} nd_n \cos npt + \\ &+ Eq \cos qt \cdot \left[ C_0 + C \sum_{n=1}^{\infty} d_n \sin npt \right] \dots (15) \end{aligned}$$

The terms in  $p \pm q$  are

$$\begin{aligned} &Ed_1C (p \sin qt \cos pt + q \cos qt \sin pt) \\ &= \frac{1}{2} Ed_1C [(p + q) \sin (p + q)t - (p - q) \sin (p - q)t] (16) \end{aligned}$$

It can be seen from the above four cases that the sum and difference frequencies have equal amplitudes only when a constant-voltage source is used with an inductance modulator or a constant-current source with a capacitance modulator. In all other cases (i.e. in all practical cases) the amplitudes are unequal, the product of lower frequency always having the smaller amplitude. The maximum ratio of amplitude of the sum and difference frequencies is  $(p + q)/(p - q)$ , attained when a constant-current source is used with an inductance modulator or a constant-voltage source with a capacitance modulator.

The lower amplitude of the difference frequency is often a severe practical disadvantage of these modulators, since it is the difference frequency which is most often required. Obviously the modulators are unsuitable for direct demodulation of a high-frequency signal to audio, say, since, firstly, the output will be low and, secondly, it will vary over the audio frequency-band.

It is interesting to note, in connection with the analysis given above, that the Fourier series used to express the time function of the modulating element in (1) and (14) are not directly convertible to the series used for the reciprocal functions in (6) and (10), although obviously the series are all quite valid. The conversion can be effected quite satisfactorily by graphical means, however. In the case of square half-wave "switching" of the inductance or capacitance (as in Fig. 2) the coefficients  $a_1$ ,  $b_1$ ,  $c_1$  and  $d_1$  are all equal to  $4/\pi$ .

### PRACTICAL DETAILS OF MAGNETIC OR INDUCTANCE MODULATOR

Some experimental work has been done on the magnetic modulator, so that practical details and results can be given. No results are available on the capacitance modulator. Throughout this section, the local (controlling) tone is referred to as the "carrier" in accordance with the usual practice in line communication work.

#### Circuit Arrangements.

Fig. 1 shows the variation of inductance and shunt

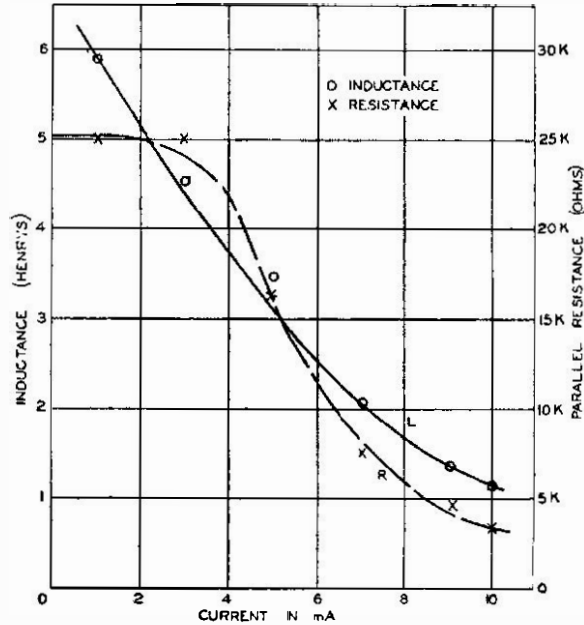

FIG. 1.—VARIATION OF INDUCTANCE AND SHUNT RESISTANCE WITH D.C. FOR SATURABLE INDUCTOR OF 1,000 TURNS, 34 S.W.G. ON MUMETAL CORE  $\frac{3}{8}$  IN.  $\times$   $\frac{3}{8}$  IN., 5-MIL LAMINATIONS. TEST FREQUENCY 50 C/S.

resistance with D.C. in a certain inductor with a mumetal core designed for operation at 50 c/s. It

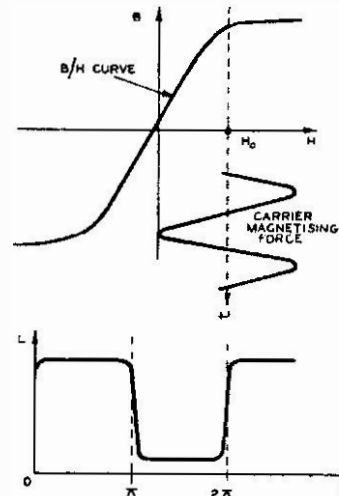

FIG. 2.—B/H CURVE FOR THE INDUCTOR, AND SWITCHING OF INDUCTANCE BY CARRIER MAGNETISING FORCE.

will be seen that a ratio of maximum to minimum impedance of about 10 is likely to be obtained. If such an inductor has a B/H curve as indicated in Fig. 2, and is polarised by a magnetising force  $H_0$ , then it can be "switched" by a carrier (sinusoidal) magnetising force from maximum to minimum impedance on alternate half-cycles of carrier as shown. If the inductor is connected across a transmission circuit (or in series, if desired) as shown in Fig. 3, then

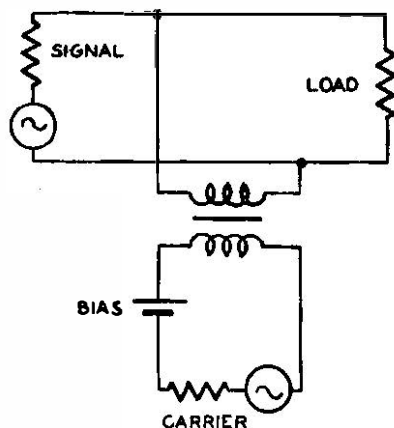

FIG. 3.—UNBALANCED MODULATOR.

evidently modulation of the signal by the carrier will take place, and a range of modulation products will be produced in the load. The circuit can be made balanced to carrier by using two inductors, as shown in Fig. 4, but, in this case, decoupling resistances  $R_D$ ,

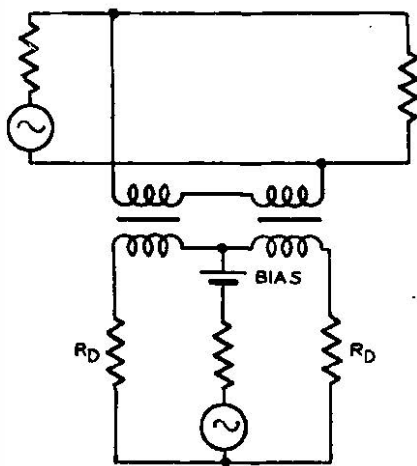

FIG. 4.—BALANCED MODULATOR.

are required to avoid short-circuiting effects due to connecting the two inductor carrier windings in parallel. It is, of course, always necessary for the carrier source impedance to be fairly high to avoid short-circuiting effects.

The use of a bias current in the coils may often be undesirable, mainly because it would prove difficult to maintain constant. The use of a bias is unnecessary if alternate half cycles of carrier are suppressed, and this may be done by the use of a rectifier as shown in

Fig. 5. The decoupling resistance  $R_D$  is required to avoid connecting the rectifier across the transmission

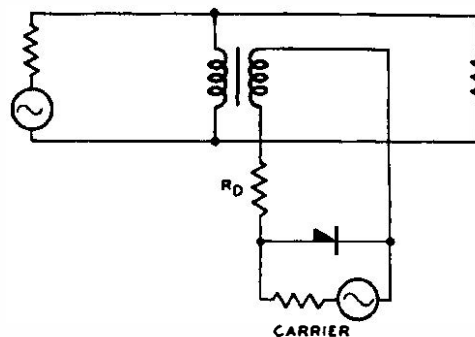

FIG. 5.—MODULATOR WITHOUT BIAS.

circuit, and the method thus requires a high carrier E.M.F. The most satisfactory circuit is probably that of Fig. 6, where a pentode valve is used to drive the

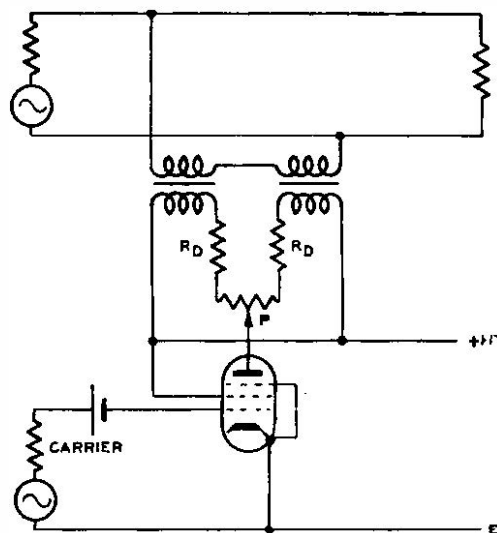

FIG. 6.—BALANCED MODULATOR WITH CLASS B PENTODE SWITCHING CIRCUIT.

carrier current through the non-linear inductors. The valve is biased back somewhat beyond cut-off, so that only positive half-cycles of carrier produce anode current. If the peak value of anode current is well above that required to saturate the inductor, then the efficiency of modulation is independent of changes (if reasonably small) in carrier voltage, grid bias voltage and valve changes. Adjustment of carrier leak can be made by suitable differential resistance and capacitance circuits; the connection of the balancing resistance is shown at P in Fig. 6.

#### Measured Results.

Laboratory tests were made with a carrier frequency of 800 c/s and input frequency of 500 c/s. The inductors (designed for these frequencies) had 700 turns (on each winding) of 36 S.W.G. wire on a bobbin made for a  $\frac{3}{8}$  in.  $\times$   $\frac{3}{8}$  in. core, but only five pairs of 5-mil mumetal laminations were fitted. The transmission circuit had generator and load impe-

dance of 600 ohms. In the circuit of Fig. 6,  $R_0$  was 1,000 ohms and P was 1,000 ohms.

Good modulation was obtained with all the circuit arrangements shown but, to avoid pointless elaboration of results, only tests made with Fig. 6 will be discussed here. To get enough current in the coils (which were originally intended for another circuit) two large valves were used in parallel but, with an increased number of turns on the valve windings, a single H.F. pentode would be adequate.

With the 500 c/s signal applied at a level which gave 775 mV across the termination in the absence of the coils, and with an anode current excursion of 45 mA (i.e. 22.5 mA in each coil) the modulation products shown in Table 1 were obtained:—

TABLE 1

| Frequency (c/s) | Type of product           | Output (mV)                                    |
|-----------------|---------------------------|--|
| 1,300           | $p+q$                     | 102  |
| 300             | $p-q$                     | 82   |
| 2,100           | $2p+q$                    | 47   |
| 1,100           | $2p-q$                    | 35   |
| 2,900           | $3p+q$                    | 9  |
| 1,900           | $3p-q$                    | 24   |
| 500             | $q$ (direct transmission) | 380  |
| 800             | $p$                       | 45   |
| 1,600           | $2p$                      | 28   |
| 2,400           | $3p$                      | 47   |
|                 |                           | With carrier leak balanced by resistance only. |
| 800             | $p$                       | 2—With capacitance balance as well.            |

Under these conditions the modulator is reasonably saturated by the carrier current, since an increase of 5 per cent. in this increases the output of 300 c/s by about 1 per cent. only.

The effect of frequency changes is shown in Table 2 and in these results the input frequency is constant at 500 c/s, but the carrier frequency is varied. The anode current excursion was rather less than in the previous test.

It is quite evident that the output of the difference frequency falls very rapidly as this difference frequency decreases. The amplitude ratio of  $(p+q)$  to  $(p-q)$

## Book Review

"Standard Valves—1947." Published by Standard Telephones and Cables Ltd., London. 300 pp. (approx.). 15s. (15s. 6d. post free).

This well-bound handbook, intended for equipment designers, gives technical information on the "Standard" valves, cathode-ray tubes, gas triodes, vacuum condensers and cold cathode tubes, which appear on the "Preferred" list or are in current production. The information is arranged in numerical order of the commercial code adopted by the manufacturers so that valves of similar type are grouped together. Where a valve is also known by a CV number, this number is given a subsidiary place so that information on a valve cannot readily be found if only the CV number is known: it is necessary first to find, from some other source, the commercial code number corresponding to the CV number.

TABLE 2.

| Carrier frequency (c/s) | Output of $(p-q)$ |      | Output of $(p+q)$ (mV) |
|-------------------------|-------------------|------|------------------------|
|                         | (freq. c/s)       | (mV) |                        |
| 800                     | 300               | 67   | 77                     |
| 750                     | 250               | 62   |                        |
| 700                     | 200               | 54   | 73                     |
| 650                     | 150               | 44   |                        |
| 600                     | 100               | 31   | 65                     |
| 575                     | 75                | 24   |                        |
| 550                     | 50                | 15.5 |                        |
| 525                     | 25                | 5.2  |                        |

outputs is less than  $(p+q)/(p-q)$ , as predicted earlier.

The loss between input and one  $(p \pm q)$  sideband (assuming this is not of very low frequency) is about 20 db. as compared with the 14 db. of a rectifier modulator of the same type (i.e. the Cowan). This high loss is due to the poor ratio between maximum and minimum impedance of the inductors; in the mumetal inductors used the ratio was about 10, compared with 1,000 or more for rectifiers. Whether this ratio can be improved or not has not been investigated.

### Acknowledgment.

The author's thanks are due to Mr. I. F. Macdiarmid for much helpful discussion in connection with this work.

### References.

- (a) Peterson, E. et al., "Magnetic Generation of a Group of Harmonics," *Bell Syst. Tech. J.*, Vol. 16, p. 437 (1937).
- (b) Tucker, D. G., "The Generation of Groups of Harmonics," *Electronic Engineering*, Vol. 15, p. 232 (1942).
- (a) Tweedy, S. E., "Magnetic Amplifiers," *Electronic Engineering*, Vol. 20, pp. 38 and 84 (1948).
- (b) Milnes, A. G., "Magnetic Amplifiers," *Proc. I.E.E.*, Vol. 96, Part I, p. 89 (1949).
- (c) Gale, H. M., and Atkinson, P. D., "A Theoretical and Experimental Study of the Series-Connected Magnetic Amplifier," *Proc. I.E.E.*, Vol. 96, Part I, p. 99 (1949).
- Reddish, W., "Cyclic Variations of Capacitance," *Wireless Engineer*, Vol. 25, p. 331 (1948).
- Van der Ziel, A., "On the Mixing Properties of Non-Linear Condensers," *J. App. Phys.*, Vol. 19, p. 999 (1948).
- Post Office Research Report No. 13005, "Biased Magnetic Modulators: A Preliminary Investigation," May, 1948.

Although the book is a neat and compact file of information, one is led to wonder for how long it will retain its neat appearance, since the Preface states that additional loose sheets will be issued periodically and there is no space within the binding for additional sheets. Moreover, the appearance of the word "Tentative Data" on 20 per cent. of the pages leads to some misgiving.

A useful feature of the book is the collection of information given in the introductory pages. Here is to be found information on ratings, on the various types of cathode, on methods of cooling and on operating conditions for mercury vapour rectifiers and thyratrons. There is also a section on valve bases, giving dimensioned drawings of some American type bases, but for British bases the reader is referred to B.S. 448. M.D.B.

# A Testing Aid for Subscribers' Apparatus Faultsmen

L. A. MISSEN

U.D.C. 621.395.721.1 : 621.317.3

A new multi-purpose test meter for subscribers' apparatus faultsmen is now undergoing field trial, and this article gives an outline of its development and design. The instrument has a more sensitive movement than that of the present standard (Detector No. 4) and in conjunction with a 67·5V flat-cell battery gives direct-reading measurements of insulation resistance. Other facilities include the normal detection of earth and battery conditions, loop resistance and A.C. and D.C. voltage measurements.

## *Introduction.*

TESTING of subscribers' lines and apparatus is, nowadays, often effected from a test desk in an exchange remote from that from which the subscriber is served. This scheme of centralised testing of subscribers' lines is applied wherever the circumstances are favourable, and finds considerable application where a large exchange (the Maintenance Control) is suitably situated to serve a number of small unattended exchanges.

There are many occasions, however, when the centralised testing scheme cannot be employed owing to the lack of spare junctions between controlling and controlled exchanges. Automatic access to subscribers on manual exchanges is not practicable and testing arrangements involving the assistance of the traffic staff at the manual exchange are not used. At the earlier type of U.A.X. no provision has been made for test selectors and, in fact, it would be difficult to find space for this equipment. At the larger U.A.X. 14, test selectors are part of the standard equipment, but the provision of junction pairs (two of which are required) is not justified economically and only where unused pairs exist can the testing equipment be utilised for centralised testing.

Thus the situation arises that, of all the staff employed in the maintenance of telephone equipment, the apparatus and line faultsmen working alone and without the elaborate testing equipment available to his colleague in the exchange or repeater station, is the least equipped for the job of fault clearance. Consideration has been given to various ways of overcoming these difficulties, notably, the development of a test selector capable of operation over a 2-wire junction, and also the possibility of combining testing with trunk offering. It is possible that a solution may ultimately be found in these suggestions. In the meantime, a multi-purpose test meter for the use of apparatus faultsmen is now undergoing a field trial.

## *Existing Testing Equipment.*

At the present time the apparatus faultsmen is equipped with a Detector No. 4, for general measurements, supplemented by a Coil, Testing No. 1 for making tests on primary batteries. This equipment is substantially unchanged from the earliest days of Post Office activity in the telephone field, when a Detector No. 2 was used.

Probably the best feature of the detectors is their robustness. The principle shortcoming is undoubtedly their insensitivity, which makes the tracing of low insulation faults very difficult.

One suggestion to improve the performance when dealing with low insulation faults utilised a hand generator and a voltage-doubling rectifier network to generate a higher voltage testing supply. A D.C. output of 150V at 10 mA could easily be obtained from this combination and the increased deflection resulting from the use of the higher voltage greatly increased the apparent sensitivity of a Detector No. 4. However, the obvious way of overcoming the difficulty is to use a more sensitive instrument, and if additional testing facilities can be added to the instrument at a small extra cost without appreciably increasing its bulk, then the introduction is justified. This principle is followed in the instrument to be described.

## DEVELOPMENT AND GENERAL DESIGN OF NEW TESTER

In any measuring instrument which is to be subjected to a great deal of handling it is essential that the movement should be robust and not easily damaged. These requirements conflict to some extent with those of a sensitive movement, and the instrument under consideration represents a compromise between these conditions. A 1 mA movement was selected as reasonably robust and in good supply, and the required sensitivity is obtained by using a 67·5V battery. This battery also makes possible the customary "ballistic" test of a subscriber's installation.

Until the improved flat-cell type of battery became available, a self-contained tester including a battery of this voltage would have been of such dimensions as to be impracticable. The conventional form of high voltage battery consisting of a number of cylindrical cells assembled in a rectangular container results in a considerable wastage of space as only a relatively low percentage of the volume is occupied by active material. The weight too, is often considerable.

The flat type of cell is constructed with the elements arranged in layers, the sequence being wrapping material, zinc sheet coated on one side with carbon, followed by the electrolyte and depolarising mix. A battery is formed by arranging the cells in pile formation. Cells are connected in series by leaving holes top and bottom, in the wrappings, so that the mix of one cell is in contact with the carbon layer of the adjoining cell. This method of construction gives a very large saving in space and the 67·5V battery used in the tester is only 2 in. × 1½ in. × 3¼ in. with a weight of 13 oz. The maximum discharge rate is 2 mA, and the shelf life is 2 years.

### Testing Facilities.

The testing facilities afforded by the instrument are :—

- (a) A.C. measurements 0 to 250V.
- (b) Detection of earth faults on a subscriber's B line and measurement of their resistance.
- (c) Detection of earth faults on a subscriber's A line and measurement of their resistance.
- (d) Detection and measurement of battery on a subscriber's B line.
- (e) Detection and measurement of battery on a subscriber's A line.
- (f) Direct-reading measurement of insulation resistance.
- (g) Direct-reading measurement of loop resistance.
- (h) Test of primary cells.
- (j) D.C. measurements 0 to 5V.
- (k) D.C. measurements 0 to 50V.

The insulation and loop resistance scales are served by 67·5V and 1·5V batteries respectively.

Consideration was given to the provision of speaking and listening facilities but it was decided that, if these facilities were provided, signalling facilities would also be required. This necessitates the provision of a hand generator and a dial which easily doubles the size of the tester and defeats one of the main objects, that is, convenience and ease of handling. Nevertheless, a tester embodying these features was obtained and given a trial. The results of this trial supported the views expressed above, and it was decided that the speaking and signalling requirements could best be supplied by the Telephone No. 250 as hitherto, and the use of the tester and telephone should be complementary in the location of faults.

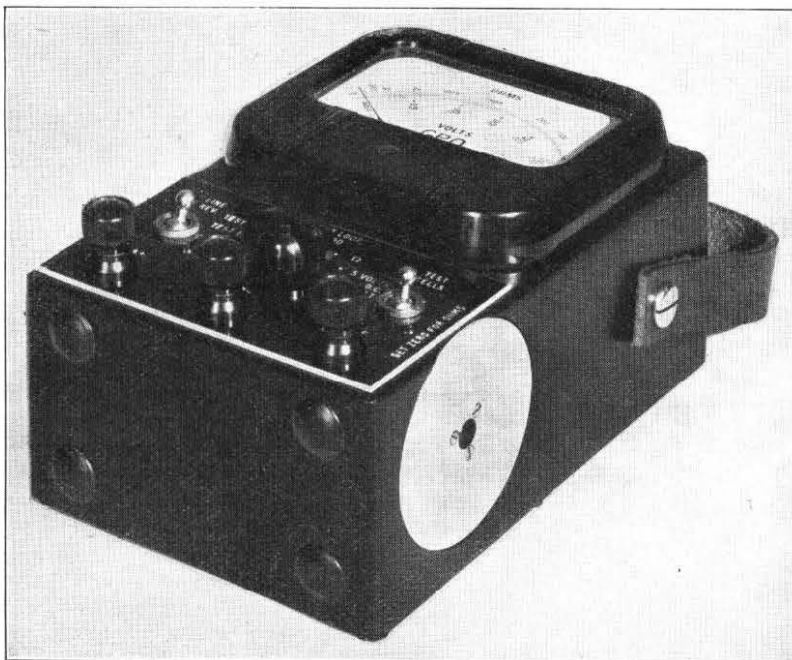

FIG. 1.—PROTOTYPE OF THE TESTER.

### Appearance, Size and Weight.

A general view of the prototype tester is shown in Fig. 1. The overall size of the tester is  $8\frac{1}{2}$  in.  $\times$   $5\frac{3}{8}$  in.  $\times$   $4\frac{3}{8}$  in., and its weight,  $5\frac{3}{4}$  lb.

It is intended that the instrument shall be kept in a leather case of the "ever-ready" type so that the maximum protection can be afforded against rough handling. The leather case is to have a hinged front which will open and fasten back to reveal the whole of the front of the instrument. The leather case will be secured to the instrument, to prevent the latter from falling out when the front of the leather case is opened, and a leather sling will be provided for ease of handling. The tester is contained in a cast aluminium case.

### Layout of Switches and Terminals.

The principle used in multi-range test meters of selecting the ranges by a rotary switch is used to apply the various test conditions. A Yaxley type switch with seven positions is arranged as in Fig. 2.

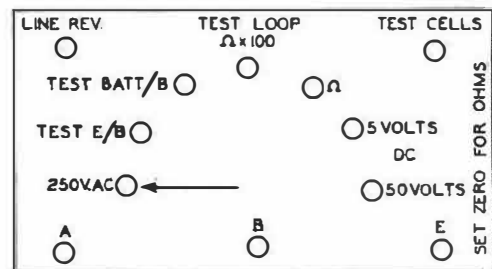

FIG. 2.—ARRANGEMENT OF SWITCHES AND TERMINALS.

In addition, there are two non-locking toggle type switches, one labelled "line reverse" and the other "test cells." Three terminals labelled "A," "B" and "E" are provided for connection to the A line, B line and earth respectively. A milled disc for making the "zero ohms" adjustment is at the side of the case.

### TEST CONDITIONS

It is intended that the test conditions should be applied in cyclic order commencing with 250V A.C. but since the basic circuit arrangement is that used for the "ohms" ranges, it is proposed to start with a description of the relevant tests.

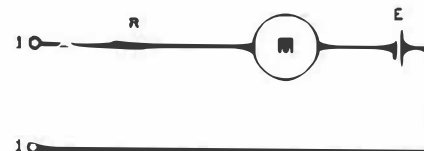

FIG. 3.—SIMPLEST CIRCUIT FOR AN OHMMETER.

The simplest arrangement for an ohmmeter is that shown in Fig. 3. For a fixed calibration, however, this arrangement gives rise to considerable

errors with battery voltage variation, a point which is explained briefly as follows.

If the range of resistance measurement is to start from zero ohms the total resistance of the instrument would be such that, with terminals 1,1 short-circuited sufficient current flows to give a full-scale deflection of the meter. Suppose the meter has a resistance of 100 ohms and requires 1 mA for full-scale deflection. If  $E$  is 1.5V, then to meet the above condition,  $R$  must be 1,400 ohms and an external resistance of 1,500 ohms added between terminals 1,1 will halve the current flowing and give a mid-scale reading. When the battery voltage drops to 1.2V, however, the resistance  $R$  must be reduced to 1,100 ohms for full-scale deflection on short-circuit and the added external resistance then necessary to give mid-scale deflection falls to 1,200 ohms. Thus, by comparison with the calibration on 1.5V the reading at 1.2V is 25 per cent. high.

To reduce this type of error it is necessary to ensure that the total resistance of the instrument is not affected appreciably by the adjustments made to cater for battery voltage variations. A simple means of accomplishing this is to use a fixed series resistance of as high a value as possible compared with the resistance of the meter, and adjust for voltage changes by a variable shunt across the meter; this principle is employed in the design of the "ohms" ranges of the tester as described below.

#### Measurement of Insulation Resistance—"Test Loop $\times 100$ ."

The circuit arrangement for this range is shown in Fig. 4, the component values being selected on the

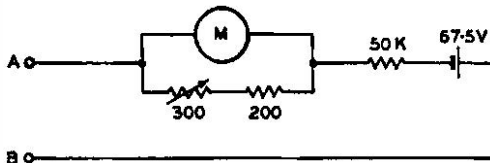

FIG. 4.—CIRCUIT CONNECTIONS FOR "TEST LOOP  $\times 100$ " RANGE.

following basis. When the battery is new, the voltage may be as high as 75 and this must be allowed for in the design. Also, to obtain a reasonable battery life, a fall in voltage must be expected and taken into consideration. Thus, taking 67.5 as a nominal voltage, a variation of  $\pm 7.5$  will give a voltage range of 60 to 75. A value of 50,000 ohms was selected as being the best mid-scale reading when making insulation resistance tests, as this coincides with the minimum permissible value for overhead lines.

Since 50,000 ohms is to be a mid-scale reading, the resistance of the instrument between terminals A and B must be 50,000 ohms and hence the current flowing with the maximum and minimum voltages, respectively, and AB short-circuited will be

$$(1) \quad \frac{75}{50,000} = 1.5 \text{ mA}$$

$$(2) \quad \frac{60}{50,000} = 1.2 \text{ mA}$$

Under each condition, it must be possible to obtain 1 mA through the meter and it is necessary to by-pass the remainder of the current through the shunt which must, therefore, be capable of accepting from 0.2 to 0.5 mA. The values of current to be by-passed by the shunt are  $\frac{1}{5}$  and  $\frac{1}{3}$  of the current in the meter and the resistance values are, therefore, five times and twice the meter resistance respectively, i.e., 500 and 200 ohms. As the minimum value of resistance is 200 ohms, this can be fixed and in series with a 300 ohms variable resistance—the "zero ohms" adjustment. These resistances are in parallel with the 100 ohms of the meter, and since their effective value is negligible compared with 50,000 ohms a series resistance of this value may be used without any appreciable loss of accuracy.

The range of the instrument on this switch position is from 0 to 5 megohms, the scale reading being multiplied by 100.

The accuracy of the instrument is greatest at mid-scale, decreasing to within 5 per cent. of the actual value between the limits of 1/10 to 10 times the mid-scale reading, i.e., 5,000 to 500,000 ohms. Outside this range the indicated values are approximate only. Similar limitations apply also to the "ohms" range.

#### Measurement of Loop Resistance—"Ohms" Range.

In considering the design of the "ohms" range (see Fig. 5) it is desirable, if possible, to use the same

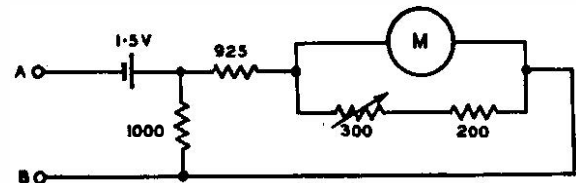

FIG. 5.—CIRCUIT CONNECTIONS FOR "OHMS" RANGE.

meter-shunting resistors for adjusting the current flowing through the meter as are used for the higher range. The 50,000-ohm series resistance is, of course, switched out of circuit.

A suitable value for the mid-scale reading is 500 ohms (the average resistance of a subscribers' line) and this is 1/100 of the mid-scale reading on the high range. A difficulty arises here since the battery voltage must be reduced proportionately, and a cell of E.M.F. 0.675V is not available. A cell of E.M.F. 1.5V is therefore used.

The shunt resistors decided upon for the high range will deal with a maximum current of 0.5 mA when 1 mA is flowing through the meter. Thus, assuming the use of 1.5V, the total resistance necessary to keep the current within these limits is 1,000 ohms.

The meter and shunt resistors have two equivalent values, i.e. 83.3 ohms and 66.6 ohms, according to the extreme settings of the 300-ohm variable resistor. The mean value is 75 ohms and, therefore, an additional 925 ohms is required to keep the current down to 1.5 mA.

This is satisfactory to give a correct maximum current flow, but the resistance of the instrument



between terminals AB is 1,000 ohms or twice the required mid-scale reading. It is necessary to reduce this to 500 ohms and this is done by adding an additional shunt of 1,000 ohms as shown.

The total current flowing is now 3 mA and this is supplied by a separate 1.5V cell of greater capacity than the battery for the higher range. The voltage of this separate cell can fall to 1.2V before the current flowing under short-circuit conditions is insufficient for full-scale deflection of the meter.

The range covered is from 0 to 50,000 ohms.

"Zero ohms" adjustment for both of the ohmmeter ranges and for the earth tests is made by short-circuiting the A and B terminals, or the A or B and E terminals, and adjusting the 300-ohm variable resistor by rotating the milled disc until full-scale deflection is obtained.

#### Test for Earth B and Earth A.

The circuit arrangement to test for Earth B and insulation resistance to earth is similar to that already described for insulation resistance. The resistors across the meter limit the current through the instrument to 1 mA and if the "zero ohms" setting is correct, the resistance measured is that of the line and the earth fault in series. This is also the insulation resistance to earth of the conductor; operation of the line reversing key applies a similar test to the A line.

#### Test for Battery B and Battery A.

For these tests the shunt resistor network across the meter is unnecessary and only the 50,000-ohm series resistance is retained. The instrument functions as a voltmeter measuring up to 50V, needing 1 mA for full-scale deflection. The reversing key is used as before to test the A line. Fig. 6 shows the connections.

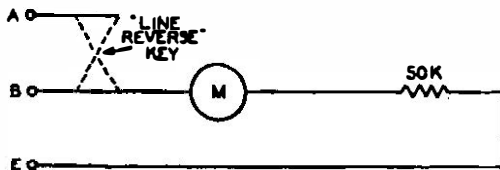

FIG. 6.—CIRCUIT CONNECTIONS FOR TESTS FOR "BATTERY A" AND "BATTERY B."

It is, of course, necessary for the E terminal of the tester to be connected to earth when testing for earth and battery.

#### Other Tests.

For the remaining tests, the instrument functions as a normal A.C. and D.C. voltmeter, but there are additional facilities on these ranges which are described in the following paragraphs.

**250V A.C.** This range is intended primarily to check that no A.C. exists on a line under test and thus avoid damage to the instrument on its other ranges. It is, however, to 1st Grade accuracy for the class of instrument and may be used for voltage measurements. A  $1 \mu\text{F}$  capacitor in series with the input to the rectifier prevents the flow of D.C. and thus avoids errors in measurement.

The rectifier also serves as a damping device to the

movement when the instrument is being transported, by acting as a low resistance shunt across the moving coil.

The circuit element is shown in Fig. 7.

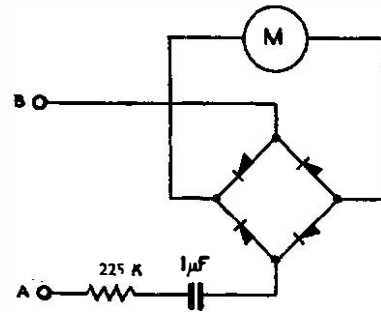

FIG. 7.—CIRCUIT CONNECTIONS FOR 250V A.C. RANGE.

**5V and 50V D.C.** On the 5V and 50V D.C. ranges, the instrument may be used as a voltmeter within these limits, or for testing primary cells, by the familiar method of comparison of voltage readings on open-circuit and under load. Operation of the "test cells" key connects a 2-ohm resistor across the A and B terminals when the Yaxley switch is in the 5V position, to test a single cell, and a 40-ohm resistor to test 20 cells in series when in the 50V position. This feature is designed to dispense with Coil, Testing No. 1 for testing cells, and has only the two values quoted for reasons of economy in space and equipment. With the "test cells" key in the unoperated position, the meter functions as a 1st Grade voltmeter with ranges 0 to 5V and 0 to 50V, according to the position of the switch (Fig. 8).

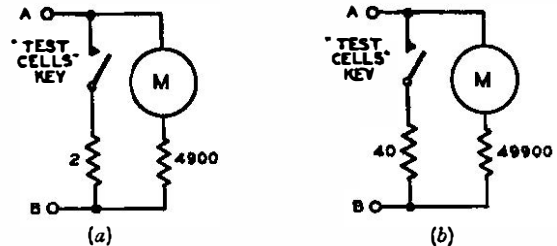

FIG. 8.—CIRCUIT CONNECTIONS FOR D.C. VOLTAGE MEASUREMENTS: (a) 0-5V RANGE. (b) 0-50V RANGE.

#### Conclusion.

The instrument described in this article is still in the experimental stage and changes to the design and in the facilities given may be found necessary as a result of the present field trial.

An instrument of this type, however, should prove of considerable value in the location of low insulation faults and, by the other facilities afforded, enable each equipped faultsmen to be his own test clerk.

#### Acknowledgments.

The design described incorporates numerous ideas and suggestions from interested parties to whom the thanks of the author are due.

Particular mention should be made of Messrs. W. L. Surman and G. G. F. Carter of the Engineer-in-Chief's Office who, at different times, were responsible for adapting these ideas to produce a practical design.

# The Contribution of the Junior Section of the Institution of Post Office Electrical Engineers

H. R. HARBOTTLE, O.B.E., B.Sc., D.F.H.,  
M.I.E.E. (President, Junior Section)

The Junior Section of the Institution of Post Office Electrical Engineers makes an important contribution to the successful working of the Engineering Department, and in these notes the President of the Junior Section outlines its past achievements and future responsibilities.

## *Introduction.*

FOR many years it has been an objective of the Post Office Engineering Department to make available to its minor staff opportunities for them to acquire a wider knowledge of their particular job and of its relation to those performed by their colleagues. In this way the individual finds added interest in his work, and takes a pride in his personal contribution as a member of a very large team.

In addition, some of those now gaining practical experience in the Junior grades will eventually occupy controlling positions in the Department, and it is highly desirable that every encouragement and assistance should be given to these officers to acquire the technical background complementary to their practical experience.

One means by which these objectives can be furthered is through the activities of the Junior Section of the Institution of Post Office Electrical Engineers, which was set up by Council in 1931, and which affords facilities to junior engineering staff for discussion and interchange of information on tele-communications and allied subjects.

The Council rightly considers the successful operation of the Junior Section to be of vital importance to the well-being of the Institution and recent indications of failing interest by Junior Section members have, therefore, given rise to some concern.

With a view to focusing attention on this matter, the following paragraphs give some account of the Junior Section, its inception, growth and activities and may assist existing and potential members to appreciate more readily the value of the facilities offered. At the same time, Senior Section members will be reminded of the essential part they can play in fostering among Juniors the desire to participate in Junior Section activities.

## *Origin.*

During the 1930/31 session, several committee members of the London Centre of the Institution of Post Office Electrical Engineers expressed the opinion at committee meetings that there was a growing desire among minor engineering grades for "Institution" facilities and instanced the number of local societies which were already in being. A sub-committee was appointed, therefore, with the object of preparing a memorandum for submission to the Council of the Institution and their approved memorandum was forwarded to Council on 4th May, 1931, with a covering letter signed by Mr. E. Gomersall, who was then chairman of the London Centre Committee and Superintending Engineer of the London Engineering District.

Council considered this memorandum and, in turn, appointed a committee to examine and report on the proposals it contained. Their report, which was issued on 30th September, 1931, was accepted by Council and has formed the basis of the Junior Section ever since.

## *Objects and Membership.*

Briefly, the report defined "Institution" facilities as "facilities for the interchange of information and ideas on telegraphic, telephonic and allied sciences," and proposed that all junior engineering staff below the ranks of Inspector and Draughtsmen, Class II, should be eligible for membership of the Junior Section which should consist of self-supporting and self-governed Local Centres formed on the initiative of the men themselves; the parent Institution acting as advisor only.

The parent Institution would, however, offer five prizes annually\* for the best papers written and read by members of, and before, the Junior Section and would afford full use of its Central Library to all members of the Junior Section for an annual fee of 6d. per member.

In addition, members of the Junior Section would be entitled to purchase copies of the professional papers of the Institution at the same reduced rates as Institution Members.

Mr. C. W. Brown was elected first president of the Junior Section by the Council in 1931.

## *Growth.*

The response from the men was most encouraging. By the end of the 1932/33 session no fewer than 47 centres had been established with a total membership of 2,200. Publication of reports of the activities of the various centres was commenced in this journal as "Junior Section Notes," and testified to the widespread enthusiasm and interest which had been aroused among the staff concerned. Visits and social events were combined with meetings to form a comprehensive programme for each session.

## *Effect of the Second World War.*

The second world war had a serious effect on the Junior Section. In general, programmes which had been prepared for the 1939/40 session had to be cancelled, although a few centres managed to continue with somewhat curtailed activities. Even before the cessation of hostilities, interest in the Junior Section began to increase and, during the 1944/45 session, 15 new Centres were inaugurated. Council decided, in 1945, that the office of President of the Junior

\*See page 172 of this issue.

Section should be revived, and appointed Mr. D. Smith to the post.

Unfortunately, these early indications of renewed interest were not maintained, and at its meeting at York in October, 1947, Council arranged to call a conference of Junior Section liaison officers and decided that the President of the Junior Section should, in future, be an ex-officio member of Council. The somewhat pessimistic report of the conference was presented to Council in January, 1948. As a result, a committee was formed to "investigate and report on the difficulties at present being experienced in the functioning of the Junior Section, and suggest remedial measures to stimulate the activities of the Section." The committee's findings were discussed at the Council meeting held at Bristol in March this year, when it was decided that all Chief Regional Engineers should be asked to co-operate with Council in a determined effort to restore the Junior Section to its pre-war standard. The subsequent action already taken by certain Chief Regional Engineers is encouraging.

#### *General Survey.*

The number of Local Centres of the Junior Section registered with the Institution is now over 90, but only 20 are functioning to the extent of holding fixtures. The membership is about 2,500 out of a potential total of over 50,000, and it does seem that, even with this comparatively low percentage, the main reason for membership of the Junior Section is the facilities offered by the Central Library of the Institution. Attendances at meetings, visits and social functions are most disappointing. Among the many explanations advanced for this unsatisfactory position is that of greater concentration on technical study.

It must be realised that when the Junior Section was inaugurated the desire for technical knowledge of telegraphic, telephonic and allied sciences was equally as great, if not greater, than at present, but the facilities for obtaining such knowledge were not so widespread or accessible. The rapid advances in communications engineering during recent years and,

in particular, wartime developments have resulted in the publication of more technical literature on the subject and an extension of the curricula of technical colleges. Moreover, the establishment at Stone of a residential Central Training School in the Engineering Department has afforded a limited opportunity for discussion and interchange of information relating to the Department's activities. Again, Regional and Area social and sports organisations should now cater for any demand which the staff may have for meeting socially.

#### *What of the Future?*

It appears that some of the functions previously fulfilled by the Junior Section have been transferred elsewhere. Nevertheless, it still can supply definite needs. The use of the Central Library of the Institution has already been mentioned in this connection.

Residential schools can supplant Junior Centre meetings to only a restricted extent in the opportunities for discussion on day-to-day problems either associated with or outside the job. The important part played by local conditions in a number of these cases can often only be appreciated by those who have an intimate knowledge of the areas concerned. Also, Local Centre meetings afford an opportunity of meeting those engaged on different phases of the same problem of providing and maintaining public communications. Men become persons to each other and the interdependence of all for the success of a satisfactory system will be realised.

#### *Conclusions.*

It is hoped that this brief account will enable the value of membership of the Junior Section to be appreciated more readily. The facilities offered, including opportunities for preparation, reading and discussion of papers with, possibly, experience in Local Centre administration should enable active members to take a lively interest in their own work and that of their colleagues; at the same time valuable experience and knowledge will be gained by members to fit them for the important tasks lying ahead.

---

## **Book Review**

"Electromagnetism." John C. Slater and Nathaniel H. Frank. McGraw Hill Publishing Co., Ltd., London, 1947. 240 pp. 40 ill. 21s.

This book is the second of a set which is intended to replace the "Introduction to Theoretical Physics" written by the same authors in 1933. The authors' aim has been the production of a short introductory text in theoretical physics, containing enough material for a term's work. In achieving this objective they have, on the one hand, excluded details of experiments or applications; on the other, they have avoided digressions of purely mathematical interest and also rigorous discussions of fundamentals. The customary dismissal of pre-Maxwellian "action-at-a-distance" theories still comes, however, as an unpleasant shock, and it is worth while to warn the student against a too ready acceptance of the conventional view. It is apparent on reading the book, that the authors' intention is to

introduce the reader to Maxwell's equations and wave theory in the shortest possible time. To this end, much has, quite rightly, been omitted: no attention is given, for instance, to conventional "lumped constant" circuit theory. About one-fifth of the text is occupied by mathematical topics necessary to an understanding of the rest of the work. Rather less than half of the remainder deals with the elements of the subject, and the rest is devoted to wave theory. Plane and spherical waves are discussed, and accounts are given of reflection, refraction, diffraction and dispersion; a separate chapter is devoted to wave guides and cavity resonators.

The text is readable and pleasantly mathematical: the m.k.s. system of units is employed. Welcome features, especially to the private student, are the inclusion of problems and of a list of books for further reading. The book is well produced and can be recommended. A. F.

# The High Frequency Broadcasting Conference, Mexico City, October 1948—April 1949

U.D.C. 654.19 : 061.3

THE object of the Conference was to make an agreement among all the countries of the world on the allocation of frequencies for high frequency broadcasting within the bands scheduled for this purpose at the Atlantic City Conference<sup>1</sup> in 1947. This was the first time that any attempt had been made to come to an agreement on this question and, since the plan envisaged involved the sharing of frequencies, both on a time and a geographical basis, and the requirements were several times greater than the number of channels in the relevant bands of the frequency spectrum, the inherent difficulties of the problem will be at once apparent.

The delegation had the responsibility for the interests not only of the United Kingdom but also of the Colonies, etc., Ceylon, Southern Rhodesia and the British Zone of Germany. Our newest Dominion was represented by Mr. Jayasekara on the British Delegation as an interim measure pending the admission of Ceylon into the I.T.U.

The frequency bands concerned were the 6, 7, 9, 11, 15, 17, 21 and 26 megacycle bands scheduled for use for broadcasting services at Atlantic City. Frequencies in these bands are used for local broadcasting in tropical or sparsely populated countries where the frequencies normally used for broadcasting are not so convenient, and also for international broadcasting for information and propaganda services over medium and long distances.

The High Frequency Broadcasting Conference at Atlantic City had established certain principles and had arranged for preliminary planning committees to meet at Geneva and at Mexico City before the main High Frequency Broadcasting Conference, and the reports of these committees were available. Unfortunately, they did not include a plan which might have served as a basis of discussion at Mexico City, and to all intents and purposes this conference, therefore, had to start from scratch.

The Conference proper opened in a large modern school building, the Escuela Normal (Fig. 1) at Mexico City on the 25th October, 1948, 68 countries being represented, and lasted for five and a half months until the 10th April, 1949. The meetings were conducted in four official languages, English, French, Spanish and Russian, and the simultaneous system of translation was used to the maximum possibility, three complete installations for this purpose being available. The interpreters' boxes in the Plenary Hall

can be seen in Fig. 2, in which can also be seen some of the members of the U.K., Indian, Indonesian, Italian and Swiss delegations.

The Conference divided its work among ten committees, the chairmanship of the Requirements Committee being allotted to the United Kingdom. This Committee was the first to report, and the fact that its report was accepted unanimously was regarded as an encouragement for the future work of the Conference. The result of its work, however, showed that the total requirements of all countries as modified by the Committee still amounted to over 12,000 channel hours, which had to be fitted into the 5,500 channel hours then thought to be available in the bands; an impossible task if countries were not willing to agree to some reduction in their demands. The General Principles Committee, set up to lay down the principles on which frequency allocations should be made to the different countries, in reality became a political forum in which many long speeches, debating points and points of order were made but which had no material influence on the practical results of the Conference. The U.S.S.R. Delegation pressed strongly for a mathematical formula based on the area, the population and the number of languages of each country to give the number of frequencies to be allocated. The danger of this proposal was that it looked so reasonable at first sight but was so fallacious in actuality, and had it been adopted in a precise form it would have resulted in the United Kingdom being allocated 53 channel hours instead of the 520 $\frac{1}{2}$  channel hours which it ultimately obtained. The Technical Principles Committee did very good work in laying down the ideal technical basis, e.g., bandwidth, frequency tolerance, protection ratios for shared and



FIG. 1.—THE Escuela Normal AT MEXICO CITY.

<sup>1</sup> P.O.E.E.J., Vol. 40, p. 175.



FIG. 2.—DELEGATION MEMBERS AND INTERPRETERS' BOXES IN THE PLENARY HALL.

adjacent channels, O.W.F. and field strength curves to be used, conditions under which more than one frequency could be used for one programme transmitter, power, aerial directivity, etc., on which the plan should be built. The United Kingdom pressed for some elasticity in these conditions in their use in the preparation of the Plan. Our proposals were defeated, but in the event were conceded in the Plan itself without much comment.

The U.S.A. and the U.S.S.R. Delegations both prepared detailed plans which entailed a tremendous amount of labour on the part of their Delegations and each of which resulted in a total allocation of about 5,500 channel hours. The U.S.S.R. Plan and the principles on which it was based were debated at very great length but it was not acceptable to more than a few countries, while that of the U.S.A. proved to be still less acceptable. The Plan Committee set up a Planning Group which attempted to lay down the number of channel hours which it regarded as the proper proportion for each country taking as a basis the possibility of obtaining about 5,500 channel hours in the bands available. These allocations proved to be acceptable to very few countries and although all delegations were asked to make realistic reductions in their requirements, these were not forthcoming and the prospects of arriving at an acceptable plan seemed to be very remote.

However, a small Working Group of the Plan Committee, under the chairmanship of the Argentine, had been formed in order to explore the possibility of a greater sharing of frequencies in the 6 and 7 Mc/s bands. This Working Group, in which the United Kingdom took a major part, decided that in order to carry out their work it was necessary to make a plan. This they did on the basis of finding out the minimum requirements of the different countries and attempting to incorporate these in the frequency space available. In order to decide

on sharing possibilities the world was divided into a number of areas, and calculations made as between the different areas for field strength, thus simplifying the study of sharing possibilities at some expense as regards accuracy. When completed this plan proved to be acceptable to quite a large number of Delegations, in fact about 83 per cent., and therefore it was obvious that the basis for an agreement had been found at last. The U.S.S.R. Delegation objected strongly to making use of this work as it had been prepared without the application of the general principles of area, population and languages which they considered as essential to any successful plan. However, as was pointed out by the United Kingdom Delegation, the justice and equity of any plan in the long run depended upon the amount of acceptance which it received from the different countries and after long debates the Plenary Assembly finally determined to ask

the small Working Group to produce plans for the remaining frequency bands, on a similar basis, and it was in this way that a plan for the June season sun spot intensity of 70 was finally produced. This had the support of 50 countries of the world, though unfortunately the U.S.A. and the U.S.S.R. with their satellites were not included in this number. The Conference then decided to set up a Technical Plan Committee to continue the work in applying this basic plan to other periods of the sun-spot cycle and to other seasons of the year, on a well-defined basis, and this committee met in Paris on 15th June.

Although the Conference lasted five-and-a-half months, the actual planning work took rather less than six weeks. The possibility of the ultimate success of the Conference will probably depend on the extent to which the countries are prepared to cut their coats according to the cloth available, as the conditions in the other periods of the sun-spot cycle are likely to prove more difficult.

The work of the Conference was often very intense, the Plenary Sessions usually carrying on into the early hours of the morning, and we finished up with an all-night sitting of the Drafting Committee prior to the final Plenary Session. The committees and working groups were very numerous and the Delegation was often hard pressed to keep the United Kingdom adequately represented.

As to matters outside the Conference, it should be said that Mexico City itself is some 7,300 ft. above sea level. Living at this altitude had its effects on hearts, lungs and digestive organs in differing degrees and some of us did not become acclimatised before a month or more of residence. With ample food available it was rather distressing to have to leave large quantities untouched, if indigestion was to be avoided, and flights of stairs had to be taken at a very easy pace. The climate, however, was adequate compensation for these effects, and during our five-and-a-

half months' stay we had only about six hours of rain. There was continuous sunshine for the rest of the time, with temperatures one would associate with a very fine May day in England, so that the English "It's a nice morning" became quite superfluous, and one felt lost for a conversation piece. There were, fortunately, interludes from work at Christmas and the New Year, and occasional week-ends, when it was found possible to get some relief from the effects of the high altitude and to see something of the fascinating country outside the City in which the Conference was held.

We shall carry memories for many years to come of the festival of the Virgin of Guadalupe with its troupes of colourful dancing Indians, of the Tule tree 160 ft. in circumference, said to be two thousand years old and the oldest-living thing, the ornate gilt Baroque and

Churrikeresque decorative work in some of the convents and churches, the bull fights, the Pyramids of Teotihuacan, the ruins of Mitla and Monte Alban, the delights of tropical sea bathing at Acapulco, the beautiful narrow cobbled old streets of Taxco, where most of us spent Xmas, and last but not least, our visit, the last part of the way in the pitch dark on horseback up the mountain side, to the new-born volcano of Paricutin, which started life in a corn field in 1943 and is now a mountain over 12,000 ft. high and is still going strong.

So it may be gathered that though Conference life is very strenuous, there are sometimes compensations and the United Kingdom Delegation are unanimous that their stay in Mexico was well worth while from all points of view.

H. F.

---

## C.C.I.F. Meetings, May and July, 1949

U.D.C. 061.3 : 621.395

NINETEEN hundred and forty-nine has been a very busy year as far as the C.C.I.F. is concerned. Technical commissions met in Scheveningen, near The Hague, over a period of three weeks in May, and in July the Plenary Assembly was held in Paris. The Plenary Assembly was preceded by a week in which most of the technical commissions met, in addition to the Operating and Tariffs Commissions, the Mixed Commission for the European Switching Plan and the Sub-Commission on Rapid Operating.

### 1ST C.E.—PROTECTION

The 1st C.E. under the chairmanship of M. Collet (France), in the absence of M. Mikhailov (U.S.S.R.), gave further consideration to the questions discussed in Paris in 1947 and to the draft of Tome II of the Yellow Book. Three new *avis* were prepared and consequential amendments made to the appropriate sections of the Directives and to the form of questions agreed to require further study in 1950-51.

Questions affecting the psophometer which are of mutual interest to the 1st and 4th C.E.s were discussed at a joint meeting. The provisionally recommended essential clauses in the specification for the psophometer were included in a new *avis* (No. 5 *bis*), and a new question was drafted to enable further study to be given to a proposed test designed to ensure satisfactory performance of the measuring instrument with peaky waves.

In 1946 the psophometer line-weighting network given in Engineering Report No. 45 of the Joint Subcommittee on Development and Research of the Edison Electric Institute and the Bell Telephone System was adopted by the C.C.I.F., but because of the absence of information from the U.S.A. on the admissible tolerances for this curve, provisional figures based on those for the existing psophometer were adopted. Recent work (British) on the design of a network to yield the results indicated by the new weighting curve has demonstrated the practica-

bility of using considerably reduced tolerances and it was decided to include the suggested reduced values in a new question for study in 1950-51. The question of how noise at the subscriber's receiver terminals should be measured was also left as a matter for further study, in co-operation with the 4th C.E.

Consequent upon the decision in 1946 that the factor of 0.7 used in calculating maximum reduced voltage had no logical justification, it was decided at the recent meeting to delete the reference to this factor from the next edition of the Directives and to amend the induced voltage limit for bare overhead wires and for cable circuits not terminated on transformers from 300V to 430V. The questions whether any further increase in this limit is practicable and desirable and whether any change in the specified breakdown voltage of protectors is necessary as a result of the present increase were agreed to be questions requiring further study.

On the question of transpositions of power line conductors it was decided that transpositions with the rotation lengths recommended in the Directives were not necessary to achieve the desired balance of harmonic voltages and currents in H.V. power lines, and that only transpositions appropriate to the particular line need be recommended.

### 2ND C.E.—CORROSION

The main work of this Commission since the last Plenary Assembly has been the preparation of recommendations for protection of underground cables against chemical corrosion and the revision of the existing recommendations for protection against corrosion caused by stray currents from traction systems. Two sub-committees under the chairmanship of M. Collet (France) and assisted by representatives of international organisations of power, gas and traction interests have worked on these recommendations at Paris (1947), Stockholm (1948) and Scheveningen (1949), and their work was considered at the recent meeting.

The original intention to draft new recommendations on chemical corrosion, in the form of a companion document to the existing recommendations on electrolytic corrosion, was modified when it became apparent that much of the material prepared in respect of chemical corrosion—i.e. choice of cable sheathing material, conditions of laying, etc.—was of much more general application than the word “chemical” implies. It was, therefore, decided to treat corrosion generally in one document, and protection from stray currents from traction systems only in the revision of the existing document on electrolytic corrosion. The former work was finished and accepted under the title “Recommendations concerning the Protection of Underground Cables against Corrosion.” The recommendations on stray current corrosion have been substantially revised and the most important question remaining for further study is the limiting value to be set on the P.D. between any two points on a traction system.

Questions agreed to require further study include the conditions under which “electric protection” methods—drainage, cathodic protection, etc.—can be applied when one of the systems concerned is a H.V. cable; and the partial or complete replacement of the lead of cable sheaths by plastics or other materials—a subject in which this country is particularly interested.

### 3RD C.E.—LONG DISTANCE TRANSMISSION

A very heavy programme of work was carried through by the 3rd C.E. under the chairmanship of Mr. G. J. S. Little (Assistant Engineer-in-Chief). The following are probably the most important matters discussed.

#### Broadcast Circuits.

For some years it has been represented by broadcasting organisations that the present International Broadcast Circuit which has an effectively transmitted band of 6,400 c/s should be improved. This has led to the agreement on a new specification for a “Normal Broadcast Circuit” for use in the future, which will have an effectively transmitted band of 10,000 c/s (see Fig. 1). The older circuits cannot, of

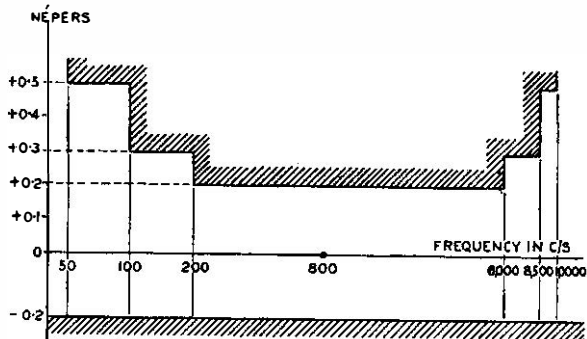

FIG. 1.—VARIATION WITH FREQUENCY OF THE OVERALL EQUIVALENT OF A COMPLETE NORMAL PROGRAMME CIRCUIT REFERRED TO THE 800 C/S VALUE.

course, be upgraded, and the old specification also remains.

#### Wide Band Systems.

Much work was done on specifications for wide band cables and equipment, and complete agreement has been obtained on a number of items. Perhaps the most important are the following.

**Noise.**—The fundamental factor involved in the design of all wide band systems is noise. This is a function of the terminal equipment, the line equipment and the length of the circuit. The British Administration has made proposals with the object of ensuring that a circuit of agreed length will meet certain noise limits by apportioning noise limits to various parts of the system.

**Reference Frequencies.**—For measurements which it is thought will be deemed necessary in the future on 12-channel groups and 60-circuit super-groups, certain reference frequencies have been agreed.

**Broadcast Circuits “Within Band.”**—With the widespread use of wide band systems a new method of providing broadcast channels has had to be developed. This method necessitates the use of three channels of a 12-channel group. It has been agreed that such a circuit will occupy the band either from 64.76 kc/s or 84.96 kc/s (in the 60-108 kc/s range), with a preference for the latter.

**Television Transmission.**—Many questions are being studied relating to the transmission of television signals on coaxial cables. Naturally the matter cannot be carried to finality until,

- (a) it is known definitely what the standards of television signals to be transmitted are;
- (b) what distortion can be permitted in the signals.

Assuming the television organisations wish to use the cables now being laid for telephony a considerable amount of information has been collected to show what can be done, and this may be useful to the authorities dealing with the standards of television. A certain amount of information on (b) was also tabled by the British Administration relative to the standards in use in this country.

**Dialling over the International European Network.**—A considerable amount of work has arisen from the 8th C.E. as a result of the study of semi-automatic working. This includes questions of level of signalling tone, variation of overall net loss and the number of circuits which may be placed in tandem.

**Music Weighting Curve for Psophometer.**—The present curve which has been in use for many years has been adversely criticised by several Administrations as not indicating correctly the effect of noise upon music transmission, and a new curve has been provisionally adopted (Fig. 2).

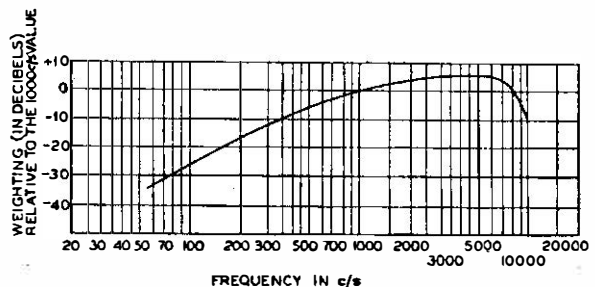

FIG. 2.—CHARACTERISTIC CURVE OF PSOPHOMETER FILTER NETWORK USED FOR MEASUREMENTS ON PROGRAMME CIRCUITS.

*Permanent Maintenance Sub-Committee.*

The Permanent Maintenance Sub-Committee also met under the chairmanship of Mr. J. T. Visser of the Netherlands Administration. A study was made of the results of a recent series of tests taken on continental circuits to determine the magnitude of the variation of overall equivalent with time. The results indicated that the variation was wider than anticipated, and it was agreed to make a more extensive series of tests over a period of six months commencing in September, 1949. It was also decided that further study should be made on the future maintenance methods of long international 12-channel groups.

4TH C.E.—LOCAL TRANSMISSION

The sub-committee for the specification of quality of transmission met in London from 24th to 29th January to make preliminary studies of certain of the questions for the 4th C.E. and of the results of articulation tests by the S.F.E.R.T. laboratory. At about this time also the equipment and personnel of this laboratory were transferred from Paris to occupy accommodation in the same building as the C.C.I.F. headquarters at Geneva. As the laboratory will, in future, contain other equipment (additional to the S.F.E.R.T.) which is usable as a reference telephone system, the name of the laboratory has now been changed to "the C.C.I.F. laboratory." The 4th C.E. met in Scheveningen from 2nd to 7th May, when it continued the study of the questions, agreed the form of replies to be made and drew up a list of questions for future study. The meeting included two sessions held jointly with the 3rd C.E.

The most urgent problem for the 4th C.E. is the devising of a standard of telephone transmission for replacing the present standard of volume efficiency; the new standard has to be acceptable and practicable for international use. Articulation tests by the S.F.E.R.T. laboratory in Paris had been made on a number of local telephone circuits (supplied by the A.T. & T. Co. in 1938) having different characteristics, e.g. in respect of side-tone or frequency limitation. The results of repetition rate tests on these different circuits had also been made available to the C.C.I.F. by the A.T. & T. Co. Relative ratings (in db.) obtained by the technique of articulation testing, now being studied by the C.C.I.F., have come to be known as values of A.E.N. (*Affaiblissement Equivalent pour la Netteté*). These values only need a correction applied to take account of the influence of side-tone on the loudness of talking to convert them into Transmission Performance Ratings, which is the result that is finally required.

Comparison of A.E.N. values, obtained on the telephone circuits from articulation tests, with effective transmission ratings (converted to a uniform level of loudness of talking), obtained from the repetition rate data, showed a close degree of correlation for the set of ten different circuit conditions supplied by the A.T. & T. Co.

Articulation tests had also been made by the S.F.E.R.T. laboratory (as it then was) on telephone sets, representative of current use, supplied by five different Administrations. Relative A.E.N. values

were assessed separately for sending, receiving and over-all, and as there were no other data against which these results could be compared, the detailed test results were subjected to close statistical analysis, which showed up certain inconsistencies and weaknesses.

To ensure obtaining reasonably precise and reliable assessments of ratings for telephone transmission from subjective tests, carried out by only a small testing staff, is not easy, but it is essential to the establishment of an international standard of telephone transmission based on transmission performance. With a view to reducing inconsistencies in test results to a minimum, the proposals resulting from the meetings in London and Scheveningen include a revision of the whole method of carrying out articulation tests by the C.C.I.F. laboratory and provision of new equipment for use as a standard of reference. It is fortunate that there is ample accommodation for the additional equipment in the new premises at Geneva.

The revised method of carrying out the tests is only to be used in conjunction with the new equipment; for the sake of continuity the method hitherto in use will be continued for all tests made with the old equipment (the S.F.E.R.T.). Alterations are proposed in the manner in which logatons are selected and the results checked, and in the method of controlling the loudness with which they are spoken. The most important change, however, is the introduction of the application of statistical methods for designing the test so that the degree of stability attained can be observed at intervals during the progress of the tests.

New equipment is, in any case, needed by the C.C.I.F. laboratory. The old Standard Reference System (S.F.E.R.T.) was presented and installed in Paris by the A.T. & T. Co. as long ago as 1928.<sup>1</sup> It is understood that it was dismantled and removed for safety at one period during the war. That it is still available for use for its original purpose (as the European reference standard for volume efficiency) is a fine tribute to its designers. Most of its components, however, are now of obsolete types, and there is difficulty in making repairs or obtaining replacements which, though seldom, are sometimes needed; this applies especially to the condenser microphones, the moving-coil receivers and the thermophone.

During the visit of the sub-committee to London in January, members took the opportunity of inspecting apparatus in use in this country. The sub-committee agreed that certain of this apparatus would be suitable for use as a new reference system for the C.C.I.F. laboratory and the British Post Office has undertaken to supply and install it in Geneva. A description of the apparatus will appear in this Journal in due course. To distinguish the new reference system from the old, the former is designated "A.R.A.E.N." (*Apareil de Référence pour la détermination des A.E.N.*).

The 4th C.E. also continued studies of long outstanding questions such as those relating to the methods of measurement of, and the effects on,

<sup>1</sup> P.O.E.E.J., Vol. 20, p. 315.



telephone transmission of room noise, circuit noise, non-linear distortion and cross-talk. In conjunction with the 3rd C.E. agreement was reached on the form of modification to be made to the curve relating limitation of frequency bandwidth with impairment.

The 4th C.E. held further meetings in Paris during the period 18th-22nd July; the main purpose of these meetings was the editing of a new C.C.I.F. publication (the Yellow Book). The opportunity was taken of further revising the list of new questions; a question was added to permit the collection of ideas relating to the practical use of transmission performance ratings (when available) in planning telephone networks.

The Plenary Assembly of the C.C.I.F. (Paris, 26th-30th July) subsequently approved the new questions and also approved the new equipment and programme of tests for the C.C.I.F. laboratory.

#### 8TH C.E.—SIGNALLING AND SWITCHING

It will be recollected that at a previous meeting it was decided to operate a field trial of semi-automatic dialling equipment to gain experience and settle some fundamental problems, and a Sub-Commission was set up to deal specifically with this trial.<sup>2</sup>

The Field Trials Sub-Commission met again in Scheveningen and reviewed the Field Trial Specification which had been prepared jointly by the British and French Administrations, certain amendments were made and the final Field Trial Specification was agreed by the 8th C.E. and incorporated in the report of that Commission to the Plenary Assembly. The chief items which provoked discussion included splitting times; establishment of speech conditions; receiver specification; and method of setting up calls involving routing through one or more transit centres.

The 8th C.E. studied the replies to questions dealt with since the previous Plenary Assembly, principal among which were: choice of frequencies for semi-auto working using 2 V.F. and 1 V.F. signal codes; supervisory signals; signal imitation; signal levels; echo suppression; and receiver insertion loss.

Joint meetings were held with the 3rd C.E. and the Rapid Operating Commission in connection with the foregoing and agreed recommendations were included in the final report to the Plenary Assembly, to whom recommendations were made for the study of some 20 new questions during the next two years.

The 8th C.E. also studied and approved proposals for modifications and additions to Tome V of the

Yellow Book, of proceedings so far as signalling and switching are concerned.

#### LETTERS AND GRAPHICAL SYMBOLS

As a result of discussions in the Symbols Committee, recommendations of the C.C.I.F. concerning letter symbols will be submitted to a joint study group of the C.C.I.F., C.C.I.R. and C.C.I.T.

The Symbols Committee proposed that whereas standard letter symbols should be used where possible, it should be permissible to substitute lower- for upper-case letters of the same alphabet and vice versa, and to replace cursive letters or letters of the Greek alphabet by the corresponding Roman letters, where no confusion is likely to arise. This resolution, if adopted, will facilitate the preparation of type-written reports.

Of particular interest is the recommendation that:—

$\Gamma$  or  $\rho$  represents the propagation coefficient.

$\alpha$  or  $a$  represents the attenuation coefficient.

$\beta$  or  $b$  represents the phase coefficient.

$P$  represents the overall propagation.

$A$  represents the overall attenuation.

$B$  represents the overall phase change.

As regards graphical symbols, it was agreed that a joint study group of the C.C.I.F., C.C.I.R. and C.C.I.T. should collate the proposals made by each of these committees on the subject of symbols for telephony, telegraphy and radio and produce a draft for submission to the International Electro-Technical Committee. Many of the proposed additions and modifications are already included in the B.S.I. Publication No. 530 of 1948, "Graphical Symbols for Telecommunications."

#### Conclusion.

The number of delegates to both these conferences was very large, but the administrations of both France and Holland went to great efforts to make the stay attractive, both from the point of view of visits of technical interest, and excursions of general local interest.

We were very glad to see M. Georges Valensi, who has been the Secretary of the C.C.I.F. since its inception, elected Director of the C.C.I.F. under its new Atlantic City Regulations.

The next series of technical commissions of the C.C.I.F. will be held in Geneva in the autumn of 1950. The 3rd C.E. will meet in London in the early spring of 1951, and the next Plenary Assembly will be in Italy in the autumn of 1951.

<sup>2</sup> P.O.E.E.J., Vol. 41, p. 50.

# The Institution of Post Office Electrical Engineers

## Essay Competition, 1949-50

The Council offers five prizes of three guineas each for the five most meritorious essays submitted by members of the Engineering Department of the Post Office below the rank of Inspector. Draughtsmen Class II, with less than five years' service on that grade, are also eligible to compete. In addition to the five prizes the Council awards a limited number of Certificates of Merit.

A prize-winner in any previous competition is not eligible to enter, but this restriction does not apply to a competitor who has been awarded a Certificate of Merit only. An essay submitted for consideration of an award in the Essay Competition and also submitted in connection with the Junior Section I.P.O.E.E. prizes, will not be eligible to receive both awards.

In judging the merits of an essay, consideration will be given to clearness of expression, correct use of words, neatness and arrangement, and although technical accuracy is essential, a high technical standard is not absolutely necessary to qualify for an award. The Council hopes this assurance will encourage a larger number to enter. Marks will be awarded for originality of essays submitted.

Competitors may choose any subject relevant to current telegraph or telephone practice. Hints on the construction of an Essay can be obtained, if desired, upon application to the Secretary at the address given below.

Foolscap or quarto size paper should be used, and the essay must not exceed 5,000 words. An inch margin is to be left on each page. A certificate is required to be given by each competitor, at the end of the essay, in the following terms:—

*"In forwarding the foregoing essay of..... words, I certify that the work is my own unaided effort both as regards composition and drawing."*

Name (in Block Capitals).....

Signature .....

\*Rank .....

Departmental Address.....

.....

Date .....

(\*If a Draughtsman Class II, state date of appointment to that grade.)

The Essays must reach

The Secretary,

The Institution of Post Office Electrical Engineers,  
G.P.O. (Alder House), London, E.C.1.

by the 31st December, 1949.

The Council reserves the right to refrain from awarding the full number of prizes or certificates if in its opinion the essays submitted do not attain a sufficiently high standard.

J. READING,  
Secretary.

## Junior Section

### Baldock Radio Station Centre

The isolated position of the station and consequently small membership has limited the activities of the Centre, but this, our first year, has been most successful. Lectures have been very well attended and our one visit, to Letchworth Power Station in January, surpassed all hopes.

At the annual general meeting in June, the following committee members were re-elected for the 1949/50 session:—

Chairman: J. E. Hewson; Vice-Chairman: A. E. Parker; Secretary: A. Crocker; Treasurer: D. Campbell.

The committee wish to thank our lecturers for the past year for their willing co-operation, and to record our gratitude to Mr. Anderton whose guidance has been mainly responsible for our success. A. C.

### Edinburgh Centre

The annual general meeting was held on 26th May, 1949, and the following office bearers were elected for the next session:—

Chairman: R. A. Notman; Vice-Chairman: J. R. Mackie; Secretary: S. M. G. Geercke; Committee: J. G. Kelly, D. Strachan, W. F. Irvine and R. C. McLean.

The committee are arranging for a series of monthly meetings and visits to local places of engineering interest. The first meeting will be held in October and will include a "Quiz" on technical topics of current interest. It is hoped that activities will be well supported.

S. M. G. G.

### Middlesbrough Centre

The annual general meeting of the Centre took place on 14th April, 1949, and the following officers were elected:—

Chairman: O. G. Prutton; Vice-Chairman: E. P. Smith; Secretary: J. Brown; Assistant Secretary: F. Fountain; Treasurer: A. Bonnier; Committee: D. Watson, R. Robinson, J. C. Hall, G. A. Buckle, C. Allison, P. A. Bulmer; Auditors: R. Hadfield, D. Paterson.

At a committee meeting held on 19th May, 1949, the programme for 1949/50 was outlined and the summer session has now been satisfactorily concluded. Visits were made to Siemens Bros. factory at West Hartlepool; the works of the Cargo Fleet Iron Co., Ltd.; the locomotive works of Messrs. Robert Stephenson & Hawthorn Ltd. at Darlington.

The programme for the winter session is as follows:—  
13th October '49.—Film show arranged by the C.O.I.

17th November '49.—Underground Development—R. V. Heppinstall (with an introduction by Mr. J. Brown of Sales Development).

15th December '49.—Some notes on Sound Reproduction—H. C. Naylor, A.M.I.E.E.

19th January '50.—Television—B. V. Northall.

16th February '50.—To be decided later.

16th March '50.—Radio Interference—P. L. Hall.

20th April '50.—Annual general meeting.

The attendance at the summer meetings has been most encouraging. It is hoped that the enthusiasm will continue during the winter session.

J. B.

(Continued on page 180)

# Notes and Comments

## Recent Awards

The Board of Editors has learnt with great pleasure of the honours recently conferred upon the following members of the Engineering Department :—

|                                  |    |               |    |                               |                             |                            |
|----------------------------------|----|---------------|----|-------------------------------|-----------------------------|----------------------------|
| London Telecomms. Region         | .. | Evans, F. R.  | .. | Skilled Workman,<br>Class IIA | Sergeant,<br>Royal Signals  | Mentioned in<br>Despatches |
| Newcastle-on-Tyne Telephone Area |    | Armstrong, A. |    | Skilled Workman,<br>Class IIB | Corporal,<br>Royal Signals  | Mentioned in<br>Despatches |
| Newcastle-on-Tyne Telephone Area |    | McEwen, J. A. |    | Skilled Workman,<br>Class IIB | Signalman,<br>Royal Signals | Mentioned in<br>Despatches |

## Birthday Honours

The Board of Editors offers its congratulations to the following members of the Engineering Department honoured by H.M. The King in the Birthday Honours List :—

|                         |    |               |                          |    |    |    |  |
|-------------------------|----|---------------|--------------------------|----|----|----|--|
| Coventry Telephone Area | .. | Miller, J. W. | Inspector                | .. | .. | .. | British Empire Medal                                 |
| Engineering Department  | .. | Faulkner, H.  | Deputy Engineer-in-Chief | .. | .. | .. | Companion of the Order of St. Michael and St. George |
| Engineering Department  | .. | Ford, F. C.   | Staff Controller         | .. | .. | .. | Officer of the Order of the British Empire           |
| Engineering Department  | .. | Mack, G. L.   | Technician               | .. | .. | .. | British Empire Medal                                 |
| Engineering Department  | .. | Mayman, A. C. | Executive Engineer       | .. | .. | .. | Member of the Order of the British Empire            |
| Swindon Telephone Area  | .. | Pearce, E. F. | Skilled Workman, Class I | .. | .. | .. | British Empire Medal                                 |

## The Post Office Directorate

Sir Raymond Birchall, K.C.B., K.B.E., retired from the post of Director General on 30th September, and the Board of Editors extends to him best wishes for the future.

The new Director General is Mr. R. A. Little, C.B., who has been succeeded as Deputy Director General by Mr. B. L. Barnett, C.B., M.C. To both these gentlemen we offer sincere congratulations on their new appointments.

## Awards by Institution of Electrical Engineers

The Board notes with pleasure that the following members of the Engineering Department have been awarded I.E.E. Radio Section Premiums for papers read before the Institution during the 1948-49 Session :—

- D. G. Tucker, D.Sc., Ph.D. "Some Aspects of the Design of Balanced Rectifier Modulators for Precision Applications" and "The Effects of an Unwanted Signal mixed with the Carrier Supply of Ring and Cowan Modulators."
- C. F. Floyd, M.A., and R. L. Corke. "Crystal Filters for Radio Receivers."
- Capt. C. F. Booth, O.B.E., and J. P. Johns (Standard Telephones & Cables, Ltd.). "The Development of Quartz Crystal Production."
- H. T. Mitchell and T. Kilvington, B.Sc. (Eng.). "A Time-Multiplex Radio Frequency Phase-Comparison Method for Navigational Systems."
- F. E. Williams, M.Sc.(Eng.). "The Design of a Balanced Armature Cutter-Head for Lateral-Cut Disc Recording."

## Reserves of Officers

The War Office has asked us to draw attention to the fact that opportunities now exist for released officers to join the Regular Army Reserve of Officers or the Army Officers Emergency Reserve. Officers with the requisite qualifications who have been released from the British and Indian Armies are required in various technical corps, including the Royal Corps of Signals.

A leaflet giving details of both Reserves may be obtained from The War Office, London, S.W.1.

## Editorial Appointment

Mr. A. J. Baker resigned from the Board of Editors on 1st September after having served as Secretary and Treasurer for over 16 years. The Board accepted his resignation with considerable regret, and now wish to express their keen appreciation of the excellent services he has rendered during his long association with the Journal.

Mr. A. J. Hutchison has been appointed to fill the vacancy caused by Mr. Baker's resignation.

## I.P.O.E.E. Printed Papers

Many requests are being received for Printed Papers now out of stock, and an attempt is being made to accumulate unwanted copies so that such requests may be met. It would be appreciated, therefore, if copies of Papers, for which members have no further use, could be sent to "The Librarian, I.P.O.E.E., Alder House, London, E.C.1."

Papers particularly requested are Nos. 138, 143, 147, 181, 186 and 188, but any others will also be gratefully accepted.

# Regional Notes

## Home Counties Region

### WAR DAMAGE REPAIRS

On the night of 28th June, 1943, a missile exploded in the switchroom of an important exchange in the Home Counties Region, completely wrecking the switchroom, battery room and telegraph room and partly damaging the apparatus room. Unfortunately, the three night operators on duty were killed.

An emergency scheme had previously been provided, and this was immediately brought into service and all essential circuits were given service. As the apparatus room was almost intact, it was decided to provide a temporary switchboard with full multiple range in the postmen's retiring room and to connect it to the existing plant in the apparatus room. This was done and the exchange was opened for service on 11th July, 13 days after the incident, and in spite of the shortcomings of the accommodation and the limited facilities provided on the temporary boards the exchange has served the area up to 28th June, 1949, six years from the date of the original destruction.

The Ministry of Works commenced rebuilding the damaged portion of the building in September 1947. The Telephone Manager's staff have now installed a new 17-position C.B. No. 10 switchboard, replaced or renovated much of the equipment in the apparatus room and provided a new installation for telegraphs and phonograms. The new switchboard was successfully brought into service on the sixth anniversary of the loss of the old exchange.

The operators, we know, are glad to be back in more congenial surroundings and no doubt the postmen will be glad to have their retiring room back once again.

C. W. C.

### CONSTRUCTION OF NON-STANDARD MANHOLE

Owing to congestion of cables, it was found necessary to demolish two adjacent manholes at the junction of Stour Street and High Street, Canterbury, and build a non-standard manhole 15 ft. x 10 ft. x 7 ft. headroom, as shown in the illustration. To do this, Stour Street had

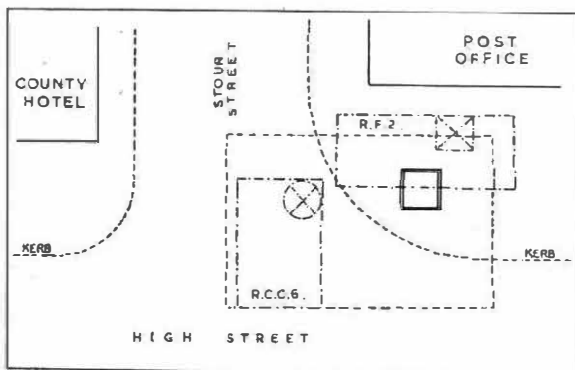

SITE OF NON-STANDARD MANHOLE, STOUR STREET, CANTERBURY.

to be completely closed to traffic at its junction with the main High Street. This was only the first of many difficulties.

It was intended that the work should be carried out by contract, but owing to the insistence of the police that the road should be reopened by 6th June, Whit Monday, there was insufficient time for the contract to be placed. Also it was known that the excavation would

be below the level of the nearby river Stour, so that if the work was postponed until later in the year the level of the river would be higher and conditions generally more unfavourable. It was therefore decided to take advantage of the fine weather, and to carry out the work by direct labour.

The manhole was on the site of an old Jeweller's market and the excavation revealed the existence of an old Roman road and many ancient relics were found, including an old brooch of some rare metal and sundry pieces of pottery dating back to A.D. 50, shown in the photograph.

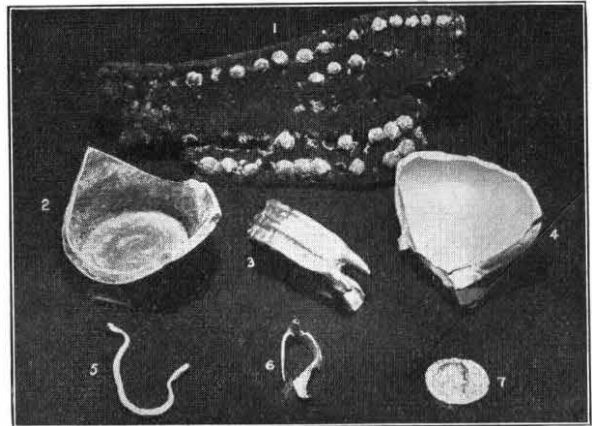

1. SOLE OF ROMAN SANDAL; 2 & 4. BROKEN ROMAN POTTERY, A.D. 100; 3. TOOTH OF AN OX; 5 & 6. BROOCHES OF RARE METAL, A.D. 50; 7. COIN DATED A.D. 79.

Owing to the proximity of tall buildings the excavation had to be close-timbered to prevent subsidence. A wooden bridge was constructed over the excavation to allow perambulators and pedestrians to pass.

Running water was encountered when excavating the last 6 in. and continuous pumping was necessary until the floor and part of the walls were constructed. The manhole was built in 14-in. brickwork and the floor and roof in aluminous cement. Nine 3½-in. steel pipes were stripped longitudinally with a Skilsaw, and the usual diversions of water and electric light mains were necessary.

However, all work was completed by the Saturday before Whit Monday, 6th June, the date specified by the police, the whole operation taking four weeks.

W. A. C.  
A. L. J.

### INSTALLATION OF THE SECOND MOBILE U.A.X. NO. 13

Until the 29th June, 1949, the telephone exchange at Naphill, Bucks, was housed in a provision store. The ownership of this store changed hands in 1949, and circumstances arose in which it became necessary to remove the exchange. Even at the time of writing, it has not been possible to obtain a site on which to erect a U.A.X. No. 13X, consequently on 5th November, 1948, the decision was taken to install a mobile U.A.X. No. 13.

Many and varied difficulties had to be overcome in making the mobile U.A.X. 13 available as only one such unit existed at that time, and that was unlikely to be available for many months. Eventually, by arrangement with the E.-in-C., two suitable vans were delivered to Brighton on 31st March, 1949, to be equipped by the Brighton Area staff. The equipping was satisfactorily carried out and the vans delivered to the Oxford Area by 24th May, 1949.

In the meantime, agreement was obtained to lease a

plot of land 83 ft.  $\times$  23 ft. near the existing exchange. Two concrete runways 3 ft. wide and 6 in. deep were laid 3 ft. apart on 6 in. of hardcore (each van weighs 7 tons and each has a 4-point suspension). A duct was laid from a convenient point in the existing duct line to a suitable point between the concrete runways.



MOBILE U.A.X. NO. 13 AT NAPHILL, BUCKS.

On delivery at Naphill, due to the restricted site, it was necessary to manhandle the vehicles on to the runways, the "B" unit caravan being backed in and the "A" and "C" unit vehicle taken in front first. This operation was not accomplished without difficulty as the road fronting the site is only 21 ft. wide, the vehicles are each 22 ft. long plus a 4 ft. 6 in. towing bar, and 7 ft. 6 in. wide, and the site is located near cross roads, with a bend approximately 100 yds. away on the busiest road. However, with the aid of the local police and some 20 manpower, including two E.-in-C.'s officers and their official driver, the vehicles were eventually lined up on site. It may be mentioned that the leading-in underground cable was run in within half an hour of the vans being positioned on site.

P.V.C. switchboard cable was used for the junction circuit tie cables between the vehicles, and run via the flexible copper tubes, then underground in a length of S.A. duct.

Wiring and testing out was completed by early June and the exchange of 150 subscribers and 16 junctions changed over, without a single fault, to automatic working on 29th June, 1949. The C.B.S. equipment and main frame were removed from the old premises on the day of transfer and the power plant from the battery hut on the following day.

Altogether operation "M.A.X." was carried out very successfully and reflects great credit on all concerned.

T. S. K.

### North-Eastern Region

#### SLEWING AND LOWERING A 3-WAY DUCT ON THE GREAT NORTH ROAD

Due to road alterations at Sinderby on the Great North Road, between Thirsk and Catterick, it was found necessary to slew and lower a 3-way main duct track

from normal cover to a maximum depth of 8 ft., over a distance of approximately 500 yds. The duct contained the Leeds-Newcastle MU cable, the Manchester-Newcastle coaxial cable and several CJ cables. The duct line was partly exposed on one side by work on the road alterations, and adjustable steel tubular scaffolding had to be used on account of the different levels. The cross members were embedded in the bank side and the vertical members were buried 2 ft. in the ground. These were fixed together with the cross members 9 ft. apart, and were struttet at intervals as shown in the illustration.

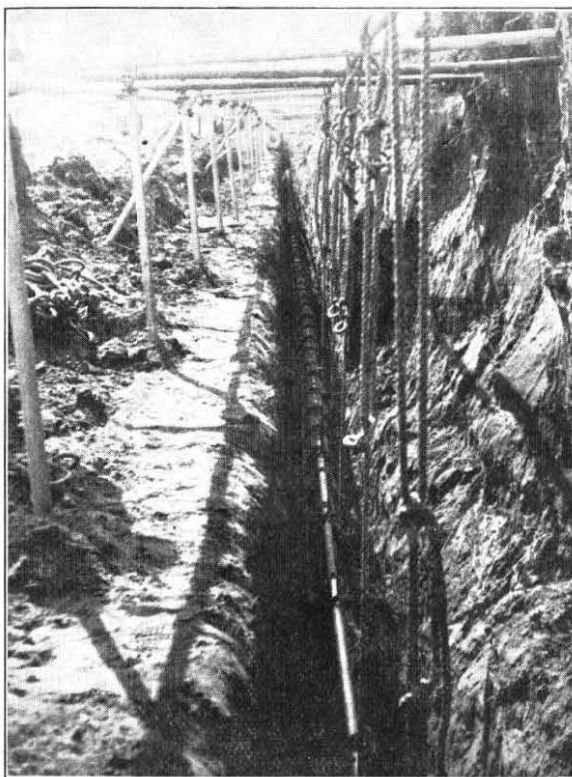

GENERAL VIEW OF METHOD OF SUPPORTING 3-WAY DUCT DURING LOWERING AT SINDERBY.

A continuous length of tubing was laid along the top of the structure at right angles to the cross members and immediately above the existing duct track. A similar length of tubing was lashed to the duct which was then suspended by new lengths of rope at intervals of approximately 6 ft. The new trench excavated was carefully measured and checked to conform to the length of track to be lowered.

*Slewing.* The top longitudinal tube was moved along the cross members to bring the ducts into position immediately above the newly-excavated trench.

*Lowering.* Thirteen men who had previously been drilled in their duties were employed, each man being responsible for two ropes. No. 1 was instructed to lower some 6 in. and refasten the rope, and this was continued throughout the first length of approximately 24 yds. No. 1 shifting to No. 14 position, No. 2 shifting to No. 15 position, and so on. The remaining lengths were dealt with similarly. The lowering was carried out in 10 operations before the ducts were finally bedded in the new trench.

After the lowering was completed the whole length

was inspected and the barrels packed where necessary. It was found that only five collars had been broken during the operation. A buried joint box midway on the section was demolished and the cables and joints lowered without any strain on, or displacement of, the joints.  
C. W. J.

### North-Western Region

#### LOWERING THE A6 ROAD UNDER SKEW BRIDGE, CARNFORTH

Anyone who has travelled along the A6 road north through the Lancaster Area, will have passed under Skew Bridge, which lies two miles beyond Carnforth and carries the main railway line between London (Euston) and Carlisle. The Lancashire County Council has recently lowered the level of the road by 4 ft. in order to give a better clearance for heavy traffic. The bridge is only 25 ft. wide, and before alteration the maximum headroom was only 13 ft. 3 in.

The photograph, reproduced by kind permission of the



SKEW BRIDGE, SHOWING NEW POSITION OF P. O. PLANT.

*Lancashire Evening Post*, was taken from the north side of the bridge and illustrates the final position of the P.O. plant.

The original surface of the road was on a level with the bottom of the third stone course below the arch, and the excavation necessitated the slewing and lowering of the 3-W.M.D. track containing the London-Liverpool-Glasgow, Lancaster-Kendal-Barrow 1 and 2, and the Carlisle-Old Boston carrier cables, for a distance of 500 ft. The maximum slewing was 4 ft. and the maximum lowering 4 ft. 6 in. A feature of the road work is the provision of a 2 ft. 6 in. railed footway on each side, which will be 4 ft. above the road level at the bridge. Opportunity has therefore been taken to provide six additional ways on the opposite side of the thoroughfare, and the end of a section of the pipes in the new footway nearing completion on the left-hand side of the bridge is indicated.

The extension of the footway beyond the bridge forms a retaining wall to the side of the cutting, and incorporates two new manholes on each track. The exterior walls of the manholes are flush with the road side of the buttress, so that in one case the footway manhole entrance is 2 ft. above the road level and the side of the manhole is visible from the carriageway.

A. S. C.  
A. M.

### London Telecommunications Region

#### MANHOLE COVER LIFTING TROLLEY

The illustration shows a lifting trolley designed and built in the L.T.R. Power Section to facilitate the lifting of heavy concrete manhole covers at the London Airport.

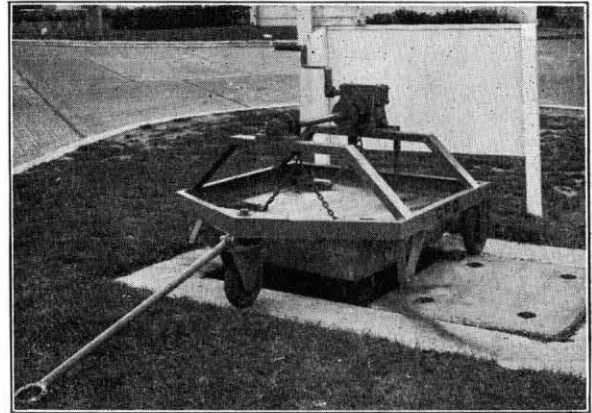

MANHOLE COVER LIFTING TROLLEY.

The covers weigh from  $\frac{1}{2}$  to  $\frac{3}{4}$  ton. As the Airport has a perimeter of about 15 miles, it is necessary for the lifting gear to be easily trailed behind a lorry. The towing bar and swivelling front wheel make this a simple matter.

The main frame is of 3 in.  $\times$  1 $\frac{1}{2}$  in. M.S. channel, welded. The chain slings are shackled to  $\frac{3}{8}$  in. diameter steel wire ropes which in turn are anchored to 5 in. diameter pulleys on the cross shaft which is rotated by means of a 20 : 1 worm gear.

The wheels are 10 in.  $\times$  2 in. Flexelle Anchored Tyre industrial type, with a safe working load of 5 cwt. Before being put into service the lifter was tested and found to lift a ton load with ease. A report received after a month's trial indicated that the device was entirely satisfactory and a further machine to the same design has been requested.  
R. W. H.

#### A NEW AUTOMATIC TOLL B EXCHANGE

On the 27th June, a new Toll B exchange installed by S.T. & C. was opened in Faraday Building for the purpose of carrying traffic from exchanges in the 12 $\frac{1}{2}$ -20 mile belt to the London Director Area, i.e. exchanges inside the 12 $\frac{1}{2}$ -mile circle.

The provision of this exchange will :—

- (a) Give relief to the Toll B manual exchange.
- (b) Permit the closing of the few remaining 7-digit order wire key-sending positions at Holborn Tandem or the "SMT" (Semi-mechanical tandem) positions as they are more familiarly known.
- (c) Release 1st code selectors on the combined Trunk/Toll B director exchange, and thus provide capacity for additional trunk circuits.
- (d) Permit the recovery of a number of 7-digit dialling routes to director exchanges, which were set up as an emergency measure to provide alternative access into the London Director Area.

The new exchange is of the director type with standard 2000-type equipment, but there are only code selectors (1st, 2nd and 3rd) in the switching train. Incoming circuits terminate directly on 1st code selectors and are all worked on a loop/disconnect basis except those from Leatherhead which, because of the existence

of a 10-lb. cable with a resistance above the loop/disconnect limit, are worked L.D.D.C. dialling. Some idea of the size of the exchange will be given by the following equipment quantities—1st code selectors, 1980 (capacity 2200), 2nd code selectors, 2127 (capacity 2880), 3rd code selectors, 630 (capacity 880). The number of calls carried per day is of the order of 50,000.

Although the introduction of full multi-metering facilities for subscriber-dialled traffic from exchanges in the 12½-20 mile belt is dependent on the provision of appropriate metering equipment, the opening of the new Toll B director exchange will enable subscribers to be given the limited facility of dialling to exchanges in a uniform fee area comprising the London 5-mile circle. Calls at the originating non-director exchanges will be routed through to the Toll B director equipment by subscribers dialling "7" as a prefixing digit to an arbitrary code for the required exchange.

An interesting feature of this exchange is the 1st code selector which is a new "Junction" type and is designed to operate on a loop/disconnect basis over a 1,500 ohm loop, and also to give supervisory or metering signals over the incoming junction. This selector has a "split release" which makes it possible for an incoming circuit to be re-seized immediately on clearance of the previous call, dialling tone to be received and dialling into the "A" digit selector and director to commence whilst on the outgoing side of the selector the wipers are still in the process of restoring to normal. This is an important feature as the selector has an 800 mS. releasing lag and, as a guard is not extended during release to the multiple at the calling exchange, seizure during this period is highly probable on such heavily-worked circuits.

R. C. D.

### Scotland

#### EARTH ELECTRODES IN A SCOTTISH LOCH

There is close parallelism between one of the North-of-Scotland Hydro-Electric Board's 132 kV lines and the Post Office overhead route in the Perthshire glen formed by Loch Tummel and Loch Rannoch. The earth fault current on the power system is at present limited by resistance-earthing at the power station. As a preliminary to the development of a 132 kV grid in the Highlands, fed by hydro-electric stations, solid neutral earthing is to be introduced in the near future. Some idea of the potential danger to Post Office linemen working on the route will be gained from the facts that the coupling between the power line and the Post Office junction most seriously affected has been measured under earth fault conditions at 2·18V per amp., and the expected maximum earth fault current will be 690 amps. next year, rising ultimately to 1,670 amps.

Initially it is proposed to provide protection for the Post Office circuits by means of gas discharge tubes connected at suitable intervals between the overhead wires and earth in order to reduce the voltage of the wires to earth under earth fault conditions on the power line. Ultimately it is possible that an A.C. signalling system will be designed so that isolating transformers can be used in the telephone circuits.

The economic provision of earth electrodes of low resistance immediately presented difficulty. The earth resistivity of the soil, mainly rock, in the part of the country concerned was found to be 200,000 ohm-cm. and, as a resistance to earth of not more than 8·5 ohms was required at each gas discharge tube point, it was evident that the provision of a buried earth electrode system would entail extensive trenching.

Fortunately, for a distance of some eight miles along

the portion of most severe parallelism, the Post Office route runs along the shore of Loch Rannoch. It was decided, therefore, to use a wire laid on the bed of the loch as the earth electrode at each of the eight protection points scheduled for this part of the route. Preliminary tests were made with 7/16 s.w.g. soft copper wire, and it was found that 400 yards of wire laid in the loch, at right angles to the shore, gave a resistance to earth of 6·6 ohms. A rough measurement of the resistivity of the water was made by immersing a pair of closely-spaced parallel metal plates, and a value of the order of 100,000 ohm-cm. was obtained—surely denoting a standard of purity for which water of the Scottish Highlands is famed in industries other than the electrical! This value of resistivity applied to the calculation of the resistance to earth of a long buried wire gave a result which agreed fairly closely with the measured value. Lengths of wire from 100 to 600 yds. were used as earth electrodes and it was found that, as predicted by theory, the resistance to earth was approximately inversely proportional to the length.

The top six inches or so of soil cover appeared to have a much lower resistivity than the lower strata. There was hardly any decrease in the resistance to earth as the spike was driven deeper into the loose rock underneath and in some cases the resistance actually increased, presumably owing to the loosening of the soil round the spike as it was hammered in.

The only craft available on the loch were rowing boats incapable of handling the weight of wire required, 19/16 s.w.g. soft copper being used for the permanent electrodes. The wire was, therefore, floated out from the shore on oil drums tied to it at intervals. A few of the oil drums were punctured and the wire sank—the remaining oil drums being crushed by the pressure of water.

Earth electrodes on other portions of the route involved many yards of difficult digging, although an occasional water pipe in the hillside was brought into service.

F. H. G.

#### LIGHTNING DAMAGE TO POWER PLANT

A fault developed at Tynatied repeater station, situated on the Central Highland route north of Pitlochry on the 23rd May, 1949. Enquiries indicated that the fault was coincident with a lightning flash which had put out of order some 150 subscribers' lines in the district and had caused a serious accident on a North-of-Scotland Hydro-Electric Board construction scheme. On inspection of the repeater station it was found that the B cubicle had been on fire, and that the neon lamp was fused into its holder, and the wiring and apparatus in the assembly supply panel was charred and burnt. Flames had spread through the cable-form holes to the inside of the cubicle and had travelled upwards along the wire former, badly burning or charring all wiring on or near the rear of all panels. Heat and some burning had been transmitted to the main contactor panel situated above the assembly panel. The whole of the apparatus in the contactor panel will probably require renewal.

From telephone enquiries it was found that a spare B cubicle was held in the Aberdeen Telephone Manager's Area and with the co-operation of that Area this was prepared and put on the road the following day. The faulty unit was withdrawn, the new unit fitted, and all plant was working normally by 6 p.m. on the day following the fault. The station was not out of service at any time, the standby plant having taken the load on the initial failure and run without interruption or difficulty for the whole period of the operation.

R. A.

# Staff Changes

## Promotions

| Name                                    | Region                                   | Date    | Name                                      | Region                       | Date    |
|---|--|---------|---|------------------------------|---------|
| <i>Exec. Engr. to Asst. Staff Engr.</i> |  |         | <i>Tech Off. to Asst. Engr.—continued</i> |                              |         |
| Rhodes, J.                              | E.-in-C.O.                               | 1.7.49  | Allwood, M. F.                            | E.-in-C.O.                   | 3.8.49  |
| Wood, A. E.                             | E.-in-C.O.                               | 1.7.49  | Bailey, A. H.                             | E.-in-C.O.                   | 3.8.49  |
| <i>Exec. Engr. to Tel. Man.</i>         |  |         | <i>S.W. II A. to Asst. Engr.</i>          |                              |         |
| Gill, C. J.                             | N.E. Reg. to Sheffield                   | 25.7.49 | James, N. S.                              | W.B.C. Reg. to E.-in-C.O.    | 6.8.49  |
| Clibbon, H. A.                          | E.-in-C.O. to York                       | 7.8.49  | Geercke, S. M. G.                         | Scot. to E.-in-C.O.          | 22.8.49 |
| <i>Engr. to Exec. Engr.</i>             |  |         | <i>Sen. Sc. Off. to Princ. Sc. Off.</i>   |                              |         |
| Bealby, G.                              | Scot.                                    | 14.7.49 | Bull, R. L.                               | E.-in-C.O.                   | 9.6.49  |
| Rossiter, G. E.                         | E.-in-C.O.                               | 14.7.49 | <i>Exper. Off. to Prob. Engr.</i>         |                              |         |
| Forty, A. J.                            | E.-in-C.O.                               | 14.7.49 | Cawthra, W. A.                            | E.-in-C.O.                   | 2.8.49  |
| Dye, F. W. G.                           | E.-in-C.O.                               | 20.7.49 | <i>Asst. R.M.T.O. to R.M.T.O.</i>         |                              |         |
| Moxon, T.                               | Scot.                                    | 17.7.49 | Mills, C. F.                              | W.B.C. Reg.                  | 5.7.49  |
| Triffitt, L. A.                         | E.-in-C.O. to N.W. Reg.                  | 26.7.49 | <i>Mech.-in-Charge to Tech. Asst.</i>     |                              |         |
| Spinks, J.                              | E.-in-C.O.                               | 7.8.49  | Palmer, S.                                | S.W. Reg. to E.-in-C.O.      | 2.5.49  |
| Thompson, A. J.                         | H.C. Reg. to E.-in-C.O.                  | 31.7.49 | Rigden, L. G.                             | London to E.-in-C.O.         | 27.8.48 |
| Whitmore, L. H.                         | E.-in-C.O.                               | 31.7.49 | Wilson, H. R.                             | Mid. Reg.                    | 10.8.49 |
| <i>Prob. Engr. to Engr.</i>             |  |         | Webber, A. L. D.                          | E.-in-C.O.                   | 28.4.49 |
| Cooper, R. A.                           | E.-in-C.O.                               | 9.6.49  | Ash, H. V.                                | H.C. Reg. to E.-in-C.O.      | 20.8.49 |
| Allnatt, J. W.                          | E.-in-C.O.                               | 5.6.49  | <i>D'sman Cl. I to Sen. D'sman.</i>       |                              |         |
| Harrison, D.                            | E.-in-C.O.                               | 16.6.49 | Porter, F. V.                             | E.-in-C.O.                   | 1.6.49  |
| Thomas, V.                              | E.-in-C.O.                               | 13.6.49 | <i>D'sman Cl. II to D'sman Cl. I</i>      |                              |         |
| Evans, G. O.                            | E.-in-C.O.                               | 21.4.49 | Macklow, C. D.                            | Mid. Reg. to W.B.C. Reg.     | 4.7.49  |
| Harriss, L. J.                          | E.-in-C.O.                               | 9.7.49  | <i>Exec. Engr.</i>                        |                              |         |
| Brett, G. E.                            | E.-in-C.O.                               | 3.7.49  | Atkinson, J.                              | Scot. to E.-in-C.O.          | 10.7.49 |
| Jones, F.                               | E.-in-C.O.                               | 1.7.49  | Porter, W. F.                             | Scot. to H.C. Reg.           | 17.7.49 |
| <i>Asst. Engr. to Engr.</i>             |  |         | Rule, F. T.                               | E.-in-C.O. to Min. of Supply | 13.7.49 |
| Bass, N. K.                             | E.-in-C.O.                               | 7.7.49  | <i>Engineer</i>                           |                              |         |
| Johnson, H. N.                          | E.-in-C.O.                               | 7.7.49  | Raby, R. E.                               | E.-in-C.O. to L.T. Reg.      | 1.6.49  |
| Pearson, F. C.                          | E.-in-C.O.                               | 7.7.49  | Goford, R.                                | E.-in-C.O. to H.C. Reg.      | 12.6.49 |
| Laver, K. S.                            | E.-in-C.O.                               | 4.8.49  | Marsh, S. B.                              | E.-in-C.O. to Min. of Supply | 27.6.49 |
| Taylor, R. E.                           | E.-in-C.O. (seconded to Factories Dept.) | 2.8.49  | Walker, N.                                | E.-in-C.O. to Scot.          | 28.7.49 |
| <i>Tech. Off. to Asst. Engr.</i>        |  |         | Jordan, T.                                | E.-in-C.O. to N.E. Reg.      | 31.7.49 |
| Garbutt, A. W. N.                       | E.-in-C.O.                               | 28.5.49 | <i>Asst. Engr.</i>                        |                              |         |
| Mathews, L. J.                          | E.-in-C.O.                               | 28.5.49 | Ansell, G. V.                             | E.-in-C.O. to Min. of Supply | 25.6.49 |

## Transfers

| Name               | Region                       | Date    | Name                  | Region                       | Date    |
|--------------------|------------------------------|---------|-----------------------|------------------------------|---------|
| <i>Exec. Engr.</i> |                              |         | <i>R.M.T.O.</i>       |                              |         |
| Atkinson, J.       | Scot. to E.-in-C.O.          | 10.7.49 | Hunt, E. T.           | W.B.C. Reg. to S.W. Reg.     | 5.7.49  |
| Porter, W. F.      | Scot. to H.C. Reg.           | 17.7.49 | <i>M.T.●. III.</i>    |                              |         |
| Rule, F. T.        | E.-in-C.O. to Min. of Supply | 13.7.49 | West, P. S.           | E.-in-C.O. to Min. of Supply | 9.6.49  |
| <i>Engineer</i>    |                              |         | <i>Tech. Asst.</i>    |                              |         |
| Raby, R. E.        | E.-in-C.O. to L.T. Reg.      | 1.6.49  | Leggett, F. W. A.     | E.-in-C.O. to London         | 28.8.49 |
| Goford, R.         | E.-in-C.O. to H.C. Reg.      | 12.6.49 | Kimberley, R. G.      | E.-in-C.O. to London         | 28.8.49 |
| Marsh, S. B.       | E.-in-C.O. to Min. of Supply | 27.6.49 | <i>Exper. Officer</i> |                              |         |
| Walker, N.         | E.-in-C.O. to Scot.          | 28.7.49 | Woodward, J. A. W.    | E.-in-C.O. to Min. of Supply | 9.6.49  |
| Jordan, T.         | E.-in-C.O. to N.E. Reg.      | 31.7.49 | <i>D'sman Cl. I</i>   |                              |         |
| <i>Asst. Engr.</i> |                              |         | Pell, W.              | H.C. Reg. to W.B.C. Reg.     | 4.7.49  |
| Ansell, G. V.      | E.-in-C.O. to Min. of Supply | 25.6.49 | <i>Exec. Engr.</i>    |                              |         |
| Green, D.          | E.-in-C.O. to N.E. Reg.      | 4.7.49  | Atkinson, J.          | Scot. to E.-in-C.O.          | 10.7.49 |
| Jackson, R. A.     | E.-in-C.O. to S.W. Reg.      | 1.7.49  | Porter, W. F.         | Scot. to H.C. Reg.           | 17.7.49 |
| Branston, E. C.    | E.-in-C.O. to L.T. Reg.      | 15.8.49 | Rule, F. T.           | E.-in-C.O. to Min. of Supply | 13.7.49 |
| Fletcher, E. N.    | L.T. Reg. to E.-in-C.O.      | 15.8.49 | <i>Engineer</i>       |                              |         |
| Rae, J. D.         | L.T. Reg. to E.-in-C.O.      | 29.8.49 | Raby, R. E.           | E.-in-C.O. to L.T. Reg.      | 1.6.49  |



**Retirements**

| Name                     | Region                | Date    | Name                     | Region      | Date    |
|--------------------------|-----------------------|---------|--------------------------|-------------|---------|
| <u>Asst. Staff Engr.</u> |                       |         | <u>Inspector</u>         |             |         |
| Morrell, F. O.           | E.-in-C.O. (Resigned) | 30.6.49 | Bennison, R. W.          | L.T. Reg.   | 24.7.49 |
| <u>Exec. Engr.</u>       |                       |         | Oliver, W.               | N. Ireland  | 31.8.49 |
| Carr, A. S.              | N.W. Reg.             | 25.7.49 | Hibbert, J.              | N.W. Reg.   | 31.8.49 |
| Turley, T. G.            | L.T. Reg.             | 31.8.49 | Hyoms, A. J. G.          | L.T. Reg.   | 31.8.49 |
| Shaw, H.                 | N.W. Reg.             | 31.8.49 | McGregor, J. H.          | Scot.       | 28.2.49 |
| <u>Engineer</u>          |                       |         | Turner, A. G.            | Scot.       | 9.3.49  |
| Law, C. V.               | Mid. Reg.             | 30.6.49 | McGregor, J. R.          | Scot.       | 31.5.49 |
| Prosser, P.              | L.T. Reg.             | 7.7.49  | Miller, L. S.            | Scot.       | 31.5.49 |
| <u>Asst. Engr.</u>       |                       |         | Sell, S. F.              | L.T. Reg.   | 9.1.49  |
| Ives, F. M.              | L.T. Reg.             | 3.7.49  | Pearson, T.              | N.E. Reg.   | 26.1.49 |
| Hall, H. C.              | L.T. Reg.             | 30.6.49 | Read, E.                 | W.B.C. Reg. | 31.3.49 |
| Robinson, G. D.          | E.-in-C.O.            | 30.6.49 | <u>Prin. Sc. Officer</u> |             |         |
| Graham, A. W.            | N.W. Reg.             | 18.5.49 | Linch, R.                | E.-in-C.O.  | 8.6.49  |
| Stanfield, J. A.         | N.E. Reg. (Resigned)  | 15.7.49 | Smith, V.                | E.-in-C.O.  | 27.6.49 |
| McIntosh, J. M.          | E.-in-C.O.            | 31.8.49 | <u>R.M.T.O.</u>          |             |         |
|                          |                       |         | Falser, F. D.            | S.W. Reg.   | 31.5.49 |
|                          |                       |         | <u>M.T.O.I.</u>          |             |         |
|                          |                       |         | Unitt, A. T. G.          | E.-in-C.O.  | 31.8.49 |

**Deaths**

| Name               | Region     | Date    | Name                         | Region    | Date    |
|--------------------|------------|---------|------------------------------|-----------|---------|
| <u>Engineer</u>    |            |         | <u>Asst. Engr.—continued</u> |           |         |
| Carr, G. E.        | E.-in-C.O. | 22.7.49 | Hardy, W.                    | L.T. Reg. | 15.7.49 |
| <u>Asst. Engr.</u> |            |         | Basleigh, F. W.              | L.T. Reg. | 23.7.49 |
| Hudson, H.         | N.E. Reg.  | 1.6.49  | <u>Inspector</u>             |           |         |
| Diprose, G. S.     | L.T. Reg.  | 25.7.49 | Caterer, G. S.               | Mid. Reg. | 24.8.49 |
|                    |            |         | Whitehead, E. H.             | H.C. Reg. | 19.8.49 |

**CLERICAL GRADES**

**Promotions**

| Name                    | Region     | Date    | Name                     | Region     | Date    |
|-------------------------|------------|---------|--------------------------|------------|---------|
| <u>H.E.O. to S.E.O.</u> |            |         | <u>C.O. to E.O.</u>      |            |         |
| Glover, G.              | E.-in-C.O. | 6.7.49  | Jones, G. A. C.          | E.-in-C.O. | 17.6.49 |
| <u>E.O. to H.E.O.</u>   |            |         | Barnes, R. J.            | E.-in-C.O. | 17.6.49 |
| Page, E. A.             | E.-in-C.O. | 6.7.49  | Pollock, K. J. M. (Miss) | E.-in-C.O. | 6.7.49  |
| Craik, A.               | E.-in-C.O. | 26.7.49 | O'Brien, R. J.           | E.-in-C.O. | 12.8.49 |
|                         |            |         | Spencer, W. S.           | E.-in-C.O. | 21.8.49 |

**Transfers**

| Name          | Region                       | Date   |
|---------------|------------------------------|--------|
| <u>E.O.</u>   |                              |        |
| Carter, L. A. | E.-in-C.O. to Board of Trade | 9.6.49 |

## JUNIOR SECTION

(Continued from page 172)

### Darlington Centre

The proposals for the 1949/50 session programme at present being discussed augur well for another successful session.

Arrangements have been made for visits to the Billingham Works of the I.C.I., a power station and a steam locomotive works to take place prior to the winter meetings.

The officers elected at the annual general meeting are:—

*Chairman*: E. O. M. Grimshaw; *Vice-Chairman*: E. Pinkney; *Secretary*: C. N. Hutchinson; *Treasurer*: B. Midcalf; *Committee*: J. Ainsley, G. C. Beggs, T. L. M. Hebron, J. Hewett, B. V. Northall, A. Snowden; *Auditors*: J. D. Benjamin, H. Richmond.

The officers are representative of the staff and were elected only after lengthy deliberations—approximately two hours was spent on this item—so that whatever programme is finally decided upon we can be confident that it will meet the requirements of the customer.

C. N. H.

### Oxford Radio Centre

The Section was formed on 1st January, 1949, and the following officers were elected:—

*Chairman*: J. L. Hyatt; *Secretary*: A. R. Jobling; *Treasurer*: D. G. Ward; *Senior Section Liaison Officer*: W. H. Lee.

The primary motive in forming the Section was to enable the staff to avail themselves of the excellent library facilities provided by the Institution. However, there was soon a demand for a programme of lectures

and a winter's programme was arranged accordingly. This proved so successful that the Committee arranged a much more ambitious programme for the 1949/50 session as follows:—

September '49.—Visit to the B.B.C. Transmitting Station at Brookmans Park, followed by attendance at a live broadcast in London.

November '49.—“The Television Receiver,” by T. Kilvington, B.Sc., of the Radio Experimental Branch.

7th December '49.—“The Principles of Radar,” by Professor A. Lee, Ph.D., of the Royal Military College of Science, Shrivenham.

January '50.—“High Voltage Distribution in the B.E.A.,” by J. L. Taylor, A.M.I.E.E., M.Am.I.E.E., A.M.I.I.A., Distribution Manager for the Oxford Area.

February '50.—“The Diesel Engine,” by S. W. Wain.

March '50.—“Matrices and their Application to Network Problems” by S. Munday, M.A., Mathematics Department, Royal Military College of Science, Shrivenham.

A. R. J.

### Sheffield Centre

Since the revival of the Centre, it is pleasing to be able to record a continuation of the enthusiasm by members, of whom there are now 65, with every indication of a further increase.

A successful summer programme included visits to:—

British Railway Control Room, Rotherham; Ladybower Dam; Ericsson's, Beeston; B.T.H. Lamp Factory, Whittington; Callender's Cables, Prescott.

Attendance at the visits and lectures has been good but it is hoped to see greater numbers, including more Youths-in-Training, in the future.

G. F.

### BOARD OF EDITORS

H. FAULKNER, C.M.G., B.Sc., M.I.E.E., Chairman.  
F. E. NANCARROW, O.B.E., A.R.C.Sc., M.I.E.E.  
P. B. FROST, B.Sc., M.I.E.E.  
A. H. MUMFORD, O.B.E., B.Sc.(ENG.), M.I.E.E.  
C. W. BROWN, A.M.I.E.E.  
W. T. GEMMELL, A.C.G.I., B.Sc., M.I.MECH.E., A.M.I.E.E.  
W. WEST, B.A., M.I.E.E.  
G. E. STYLES, A.M.I.E.E., Managing Editor.  
W. A. HUMPHRIES, A.M.I.E.E. } Assistant Editors.  
J. P. HARDING, B.Sc.(ENG.) }  
A.M.INST.C.E., A.M.I.E.E. }  
A. J. HUTCHINSON, Secretary-Treasurer.

### Copyright

The entire contents of this JOURNAL are covered by general copyright, and special permission is necessary for reprinting long extracts, but Editors are welcome to use not more than one-third of any article, provided credit is given at the beginning or end thus: “From the *Post Office Electrical Engineers' Journal*.”

The Board of Editors is not responsible for the statements made or the opinions expressed in any of the articles in this JOURNAL, unless such statement is made specifically by the Board.

### Communications

All communications should be addressed to the Managing Editor, *P.O.E.E. Journal*, Engineer-in-Chief's Office, Alder House, Aldersgate Street, London, E.C.1. Telephone: HEADquarters 1234. Remittances should be made payable to “*The P.O.E.E. Journal*” and should be crossed “& Co.”

### Binding Cases

Cases for binding are available, and may be obtained from the Local Agents for 2s. Subscribers can have their copies of Volumes bound, at a cost of 7s. 6d., by sending the complete set of parts to the Local Agents or to the *P.O.E.E. Journal*, Engineer-in-Chief's Office, Alder House, Aldersgate Street, London, E.C.1. Orders for binding for Vols. 1-19 should indicate whether the original binding case with black lettering, or the later pattern with gold, is required. Cases with gold lettering are the only type stocked from Vol. 20 onwards.

### Back Numbers

The price of the JOURNAL, which is published quarterly, is 1s. 6d. (1s. 9d. post free) per copy, or 7s. per annum post free. Back numbers can be supplied, subject to availability of stocks, at 1s. 6d. each (1s. 9d. post free). Orders for back numbers may be sent to the Local Agents or to the Publishers.

### Advertisements

All communications relating to space reservations should be addressed to the Advertisement Editor, *P.O.E.E. Journal*, Alder House, Aldersgate Street, London, E.C.1. Communications regarding advertisement copy, proofs, etc., should be addressed to the Publishers, Messrs. Birch & Whittington (Prop. Dorling & Co. [Epsom], Ltd.), 49 Upper High Street, Epsom, Surrey.



# R.F. ATTENUATOR TYPE D-239

## BRIEF SPECIFICATION

ATTENUATION RANGE : TYPE D-239-A : 0—61.5 db variable in steps of 0.5 db. TYPE D-239-B : 0—80 db variable in steps of 1 db. CHARACTERISTIC IMPEDANCE : 75 ohms ("T"-network). PERFORMANCE : At frequencies up to 5 Mc/s and for any setting of the switches the error in attenuation will not exceed  $\pm 0.2$  db. Reasonable accuracy is maintained up to 10 Mc/s. TERMINATIONS : Coaxial connectors. INPUT : 3 volts maximum. DIMENSIONS :  $6\frac{1}{2}$  in.  $\times$   $2\frac{3}{8}$  in.  $\times$   $5\frac{1}{4}$  in. WEIGHT :  $2\frac{1}{2}$  lbs. Manufactured to a design of the Radio Branch of the Post Office Engineering Department.

Full details are given in Bulletin B-562-B, a copy of which will be sent on request.

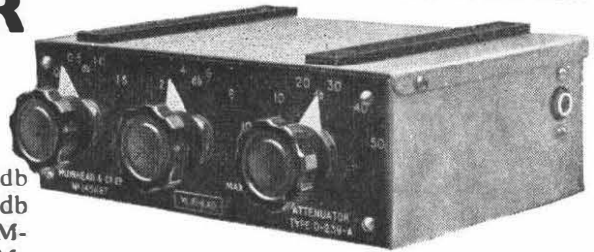

THIS small compact attenuator is characterized by a wide range of attenuation and outstanding accuracy at high frequencies. Wire wound resistance elements ensure accuracy, good stability and freedom from noise. It can be used as a bench instrument or for incorporation in other apparatus where its small size is a considerable asset. Two types, giving alternative values of total attenuation, are available.

## MUIRHEAD

Muirhead & Co. Ltd., Elmers End, Beckenham, Kent. Telephone: Beckenham 0041-2.  
FOR OVER 60 YEARS DESIGNERS AND MAKERS OF PRECISION INSTRUMENTS.

C.R.C. 69b

## UNIVERSALLY ADOPTED

# G.N.T.Co. TRANSMITTER MODEL II2

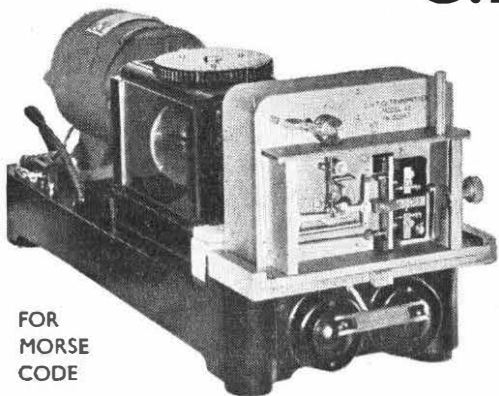

FOR  
MORSE  
CODE

13-250 words per minute without gear changes or readjustments.

Absolutely constant speed at all settings notwithstanding large voltage variations.

Noted for its easy maintenance.

Supplied with A.C. or D.C. motors as required.

**THE GREAT NORTHERN TELEGRAPH CO. LTD.**  
OF DENMARK

KONGENS NYTORV 28  
COPENHAGEN K. - DENMARK

AND

5, ST. HELEN'S PLACE,  
LONDON, E.C.3

# American Insurance Companies advise regular use of "MEGGER" EARTH TESTERS

## *Lightning Damage caused by High Earth Resistance*

THE INSPECTION DEPARTMENT of the Associated Factory Mutual Fire Insurance Companies, of Boston, Massachusetts, issues a Bulletin of Loss Prevention. No. 15.66 contains a word of warning about Lightning damage and an indirect tribute to British testing equipment.

The Bulletin points out that "in spite of good lightning arrestors and similar devices, lightning will frequently cause severe damage if high earth resistance hampers its dissipation in the earth."

It advocates that earth resistances should be checked annually, and points out that "the 'Megger' Earth Tester is the easiest, quickest and most accurate method of doing this, and should be employed wherever possible."

"Megger" Earth Testers are used to test the soil resistivity as a guide to the position, size and type of earth

electrode: after installation, to see that the initial resistance is sufficiently low: and to check periodically this resistance to see that its low value is maintained. They enable the resistance to earth of an earth plate or structure to be measured directly in just as simple a manner as insulation can be measured with a "Megger" Insulation Testing Set. The Earth Testers are so designed that any electrolytic or back E.M.F. or stray currents in the soil do not affect the test in any way.

"Megger" Earth Testers comply with the testing requirements laid down in the I.E.E. Regulations. Each consists of an ohmmeter and generator of special type, so designed that alternating current is used in the testing circuit in the soil, while direct current is used in both coils of the ohmmeter.

Full details are available in Publication X 217, a copy of which will be sent on request.

## THUNDERSTORM FORECASTING IS POWER STATION SAFETY AID

An Evershed chart recorder is used in conjunction with a Ferranti calibrated radio receiver to give warning of approaching thunderstorms.

A continuous record of atmospheric is obtained, and it is claimed that the approximate distance of the storm centre can be deduced from the chart record. In some instances several hours warn-

ing may be obtained so that operating staff may, where possible, take appropriate precautionary measures to safeguard the electrical supply.

Eversheds make recorders for all kinds of special requirements and many strange purposes.

### EVERSHED

PROCESS CONTROLLERS  
INDICATORS & RECORDERS  
REMOTE CONTROLLERS  
MEGGER TESTERS

## MEGGER TESTERS CAN TAKE IT

"For 25 years the writer has professionally used a hand 'Megger' Set throughout the Philippines. The Set 'Evershed & Vignoles, 100-Meggohm—Serial No. 59289' has withstood successfully the harshness of Philippine trail and transportation service without renewal or changing Megger parts and the still excellent condition of its wooden container box, free from checks or climatic cracks is frequently commented upon by those interested in the conditioning of wood containers for longevity of life under tropical conditions."

—from a customer in the Philippines.

PLEASE —

*I'm registered!*

No need to introduce myself. I'm a Megger. Every electrical engineer knows me.

That's half the trouble. You all know me so well — wouldn't be without me, most of you — that some of you are inclined to forget who I really am.

It is nice being popular, and I don't want to stand on my dignity with friends. But the Law doesn't like me being taken so much for granted.

The Law recognises me as a registered Trade Mark. It says my name must only be used for the products of Evershed and Vignoles. That suits me — they're the best, anyway. The Law even says I'm an adjective, and must not be used as a noun.

So please remember that I'm not just a "Megger," but quite definitely a "Megger" Earth, or Insulation or Earthometer Tester — and that Evershed's made me.

BRABAZON I. Britain's largest landplane has been fitted with Evershed engine throttle controls. Engineers report: "Trouble free service . . . no difficulties or complaints."

## EVERSHED AND VIGNOLES LIMITED

ACTON LANE WORKS · CHISWICK · LONDON · W4

Telephone: Chiswick 3670    Telegrams: Megger, Chisk, London    Cables: Megger, London

# CARPENTER Polarized RELAY TYPE 4

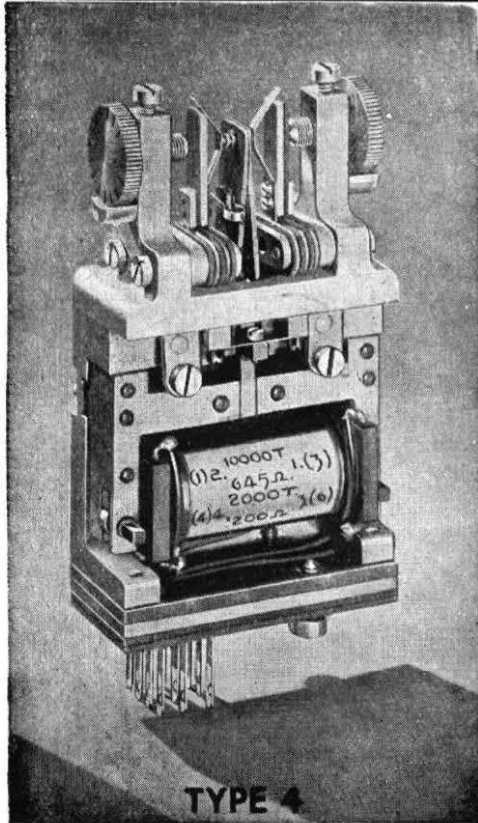

This is a medium speed, sensitive relay with long contact travel designed primarily as a telephone impulsing relay (D.C. dialling up to 100 miles and V.F. dialling on trunk circuits). It has also been successfully adopted for use in Telex systems.

Its sensitivity is such that when the gap is adjusted to .004 in. the relay will just operate at 50 cycles with 4 ampere-turns (corresponding to approximately 1 mVA) or on  $2\frac{1}{2}$  D.C. ampere-turns at low speeds. In service, however, the relay is normally operated at currents substantially larger than the minimum operating current.

Contact chatter is absent if the contact gap does not exceed .004 in. The contact gap is adjustable by means of fine pitch screws with knurled heads marked with .001 in. divisions.

Contacts on the armature tongue are insulated from it and thereby from the frame.

Terminals for soldered connections are fitted as standard.

The relay is supplied with a magnetic screening cover with transparent removable top to facilitate contact adjustment.

Dimensionally the relay is interchangeable with the type "3000" relay and can be supplied to fit directly to the drilling normally provided for the "3000" relay.

Dimensions of the Type 4 Carpenter Relay are:— (With cover. Excluding wiring tags)  
 $3\frac{3}{8}$  ins. high x  $2\frac{1}{8}$  ins. wide x 1 in. deep. Weight: 13 ozs.

Complete detail available on request.

Manufactured by the Sole Licences:—

## TELEPHONE MANUFACTURING CO. LTD.

Contractors to the British Commonwealth and Foreign Governments

HOLLINGSWORTH WORKS • DULWICH • LONDON, S.E.21

Telephone: GIPsy Hill 2211 (10 lines)

"We wonder how we managed before"



**LIFT-LOAD-CARRY**  
1-2-3 TON

at less cost with the

**STANHAY**  
ASHFORD LTD

**PNEUMATIC MOBILE CRANE**



SEE ALL ITS TECHNICAL ADVANTAGES BY SENDING TODAY FOR THIS



FREE BROCHURE TO STANHAY LTD. ASHFORD, KENT



**FREDERICK SMITH & COMPANY**

(Incorporated in The London Electric Wire Company and Smiths, Limited)  
ANACONDA WORKS, SALFORD 3, LANCs.  
Phone: Blackfriars 8701 (9 lines) • Grams: "Anaconda," Manchester

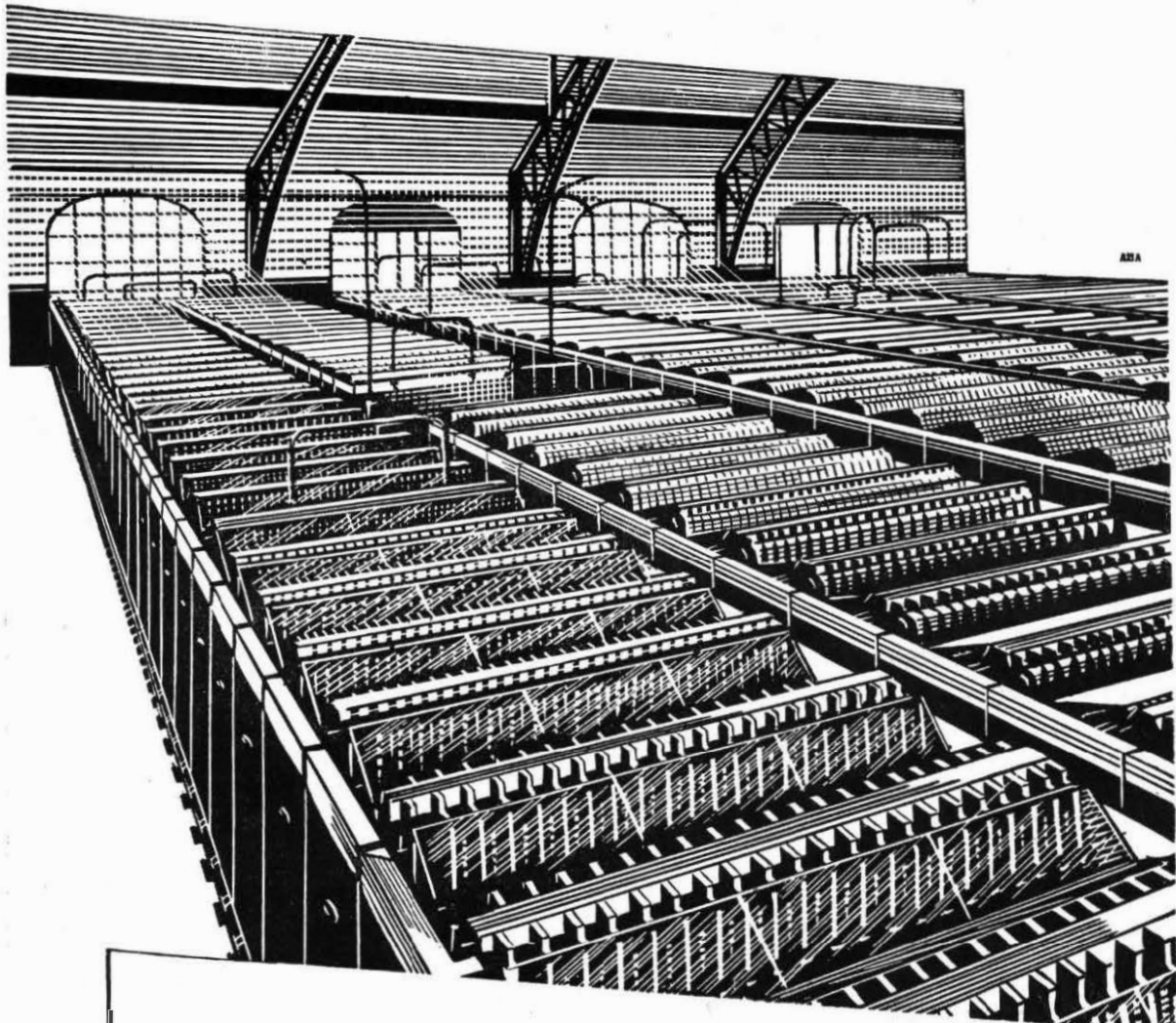

Alton is a big name in the export market. These good batteries, in capacities from 10 to 15,000 ampere-hours, are in service in sixty-five countries. Alton is ready to meet orders from any part of the world and to give firm delivery dates

# ALTON

## BATTERIES OF MERIT

THE ALTON BATTERY COMPANY LIMITED

Alton, Hants. Telephone: Alton 2267 and 2268

Telegrams: Battery, Alton

*Alton can also supply renewal plates for all makes of battery, British & Continental*

**Eclipse** PERMANENT MAGNETS



IN  
**TUNGSTEN · CHROME  
COBALT · ALNI · ALNICO  
& ALCOMAX**

Our Technical Development Section will be pleased to advise on any problem connected with applied magnetism

Made by the manufacturers of  
"ECLIPSE"  
PERMANENT MAGNET CHUCKS

MM7

JAMES NEILL & CO. (Sheffield) LTD., SHEFFIELD, ENGLAND

STUDY  
AT  
HOME

You Can Have a College Training  
For a Few Shillings Monthly

IN YOUR  
SPARE  
TIME

**CITY and GUILDS**  
(Telecommunication)  
**EXAMINATIONS**

To every student we send  
a written Guarantee of  
Tuition until the  
examination is  
actually  
passed

*The most progressive and most successful  
Correspondence College in the world*

Our  
tuition  
is so graded  
that each stage  
is reached without  
difficulty.  
Personal attention is given  
to every student.

FULL PARTICULARS AND  
ADVICE SUPPLIED FREE.  
WE TEACH BY POST IN ALL  
PARTS OF THE WORLD.

*The* **Bennett College** *Limited*



Dept. 24, THE BENNETT COLLEGE, SHEFFIELD

*For reliable, continuous and quiet service . . .*

**"SPEEDIVAC" Rotary Pumps**

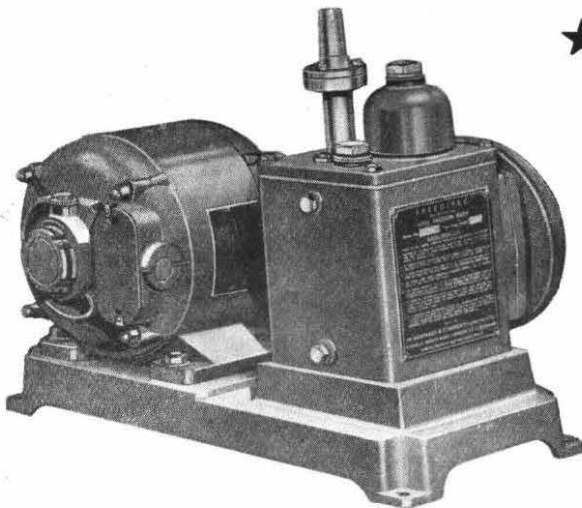

Electronic industries throughout the world are being well served by all models of the famous "SPEEDIVAC" range of rotary pumps. Specially designed for instructional, research and production work connected with the manufacture of discharge tubes, valves and lamps, cathode ray tubes, metallic coatings in the production work of quartz crystal, condensers, resistors, etc.

**The MODEL 2S20 (illustrated)**

is a brilliant newcomer to the laboratory—and the "SPEEDIVAC" range—with an ultimate vacuum of 0.0001 mm. Hg. and a displacement of 20 litres/min.

*. . . For Better Vacuum Service . . .*

**W. EDWARDS**

Telephone : SYDenham 7026 (8 lines)

**& COMPANY (LONDON) LTD.**  
LOWER SYDENHAM, LONDON, S.E.26

Telegrams : EDCOHIVAC, Souphone, London



13

# Creed

## TELEPRINTERS

*Built by specialists  
in machine telegraphy~*



N° 47 TAPE MODEL

*Write for  
Bulletin N° 21*

**Creed & Company Limited**

TELEGRAPHY HOUSE  
CROYDON, ENGLAND

# EDISWAN

## Telephone Line Protectors

FOR THE PROTECTION OF LINES OF COMMUNICATION FROM SURGES INDUCED BY LIGHTNING OR FAULTS ON NEIGHBOURING POWER LINES

Ediswan Telephone Line Protectors have now been in commission for nearly twenty years. They have proved their worth in all parts of the world and are being called for and installed in ever increasing numbers. Many thousands were employed during the war years for the protection of vital lines of communication and were eminently successful. Reports of their outstanding merit and successful operation continue to reach us and in recent years they have proved of particular interest for protection against surges caused by lightning discharges.

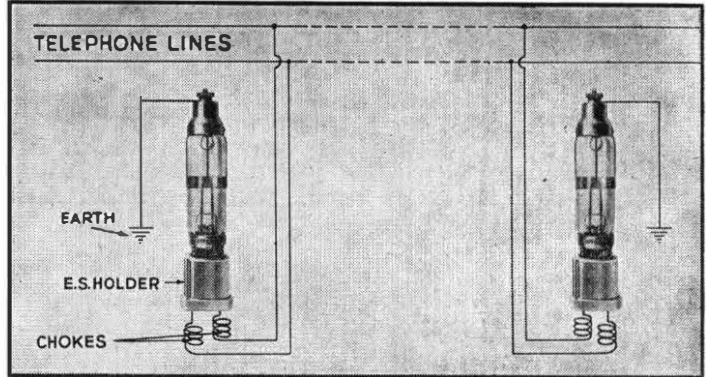

Continued research has enabled us to patent a further improvement which removes any suggestion of delay in operation.

Further information and prices on application.

THE EDISON SWAN ELECTRIC CO. LTD., 155 CHARING CROSS ROAD, LONDON, W.C.2

T.E.3

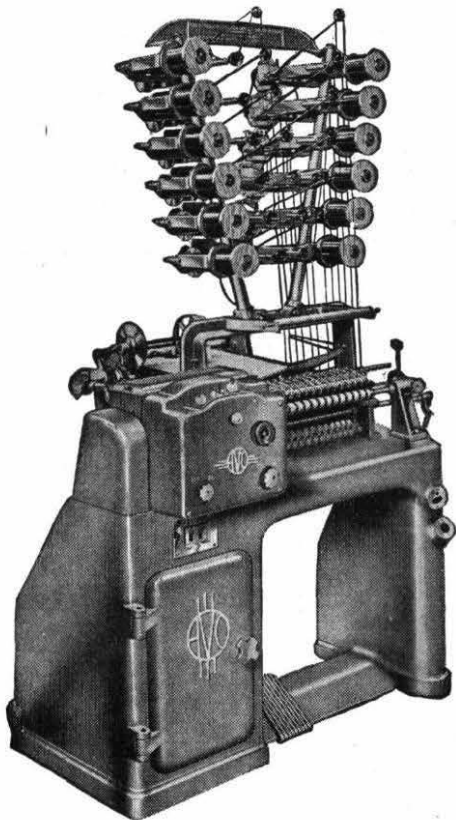

## DOUGLAS AND MACADIE

### Automatic COIL WINDERS

The large illustration depicts the new improved "Douglas" Fully Automatic Multi-Winder, specially developed for the high-speed production of large quantities of coils with or without paper interleaving. It will produce round, square

or rectangular coils up to 6 in. each in length and up to 4½ in. diameter. As many as 12 smaller coils can be wound simultaneously within the total available winding length of 12 in. at headstock speeds of between 600 and 2,000 r.p.m.

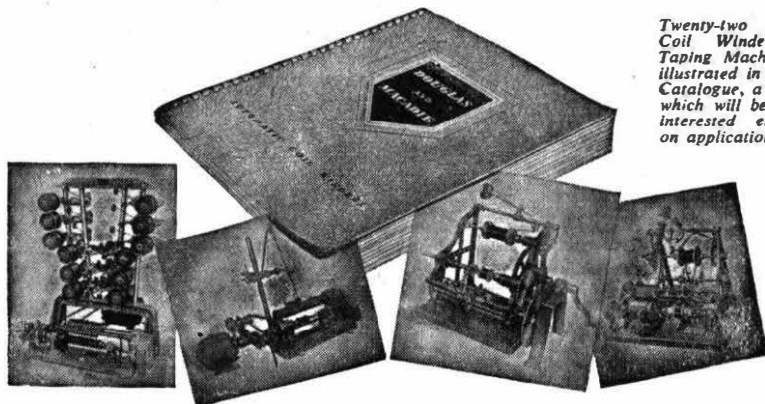

Twenty-two different Coil Winders and Taping Machines are illustrated in our new Catalogue, a copy of which will be sent to interested executives on application.

Sole Proprietors and Manufacturers :

The AUTOMATIC COIL WINDER & ELECTRICAL EQUIPMENT CO. LTD.  
WINDER HOUSE • DOUGLAS STREET • LONDON • S.W.1 Telephone: VICTORIA 3404/9

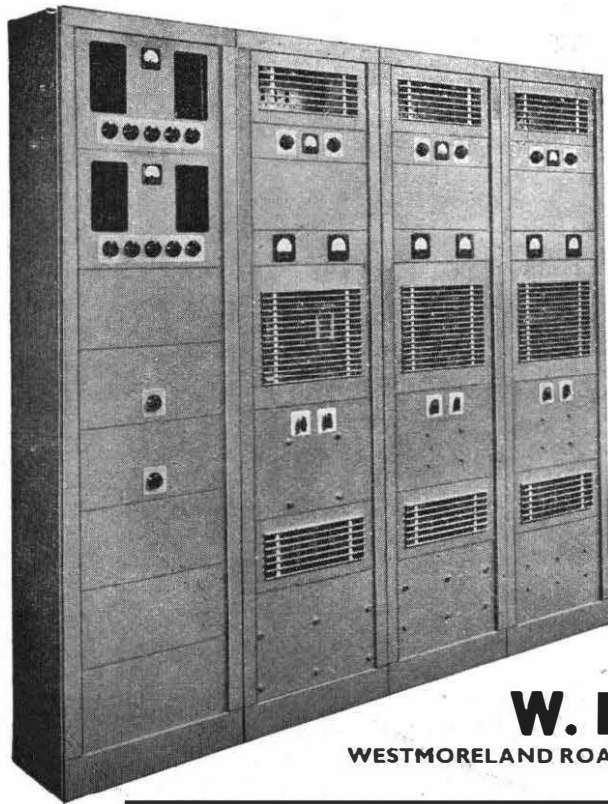

*The Mark II series of*  
**SAVAGE AMPLIFIERS**  
*for Broadcast Relay*

● These Amplifiers are examples of what careful design can achieve. A lift-off back panel affords immediate access for maintenance purposes and the removal of six screws releases the side covers of the rack and exposes all the interpanel wiring. Even when the rack is sandwiched between others the side covers can be moved just as easily. All valves are accessible from the front of the rack, and are protected by quick release grilles. The rack is completely flat fronted. The general appearance is further enhanced by the absence of a projecting front foot, and the marking of all panel fixing bolts. Similar racks carrying auxiliary apparatus can be placed side by side with amplifiers so that the whole installation is uniform in appearance. Complete specifications available on request.

**W. BRYAN SAVAGE LIMITED**

WESTMORELAND ROAD · LONDON N.W.9 · TELEPHONE: COLINDALE 7131

200100 NON-LOCKING  
200101 LOCKING

ALTERNATIVE CONTACT ARRANGEMENT

200104 NON-LOCKING

OPERATING ALLOWANCE

5/8 AF

1/8

1 1/32 + 3/32 + 5/16

3/8

3/8

3/4

NOW AVAILABLE FOR EARLY DELIVERY

1 2 3 4

miniature  
 PUSH BUTTON SWITCH  
 A TYPE APPROVED COMPONENT

control by **PAINTON**

⚡ RATING 250V AT 0.1 AMPS  
 ⚡ CONTACT RESISTANCE 0.1 ohms  
 ⚡ BERYLLIUM COPPER CONTACTS

**1 CENTRALISED**  
RESEARCH, DESIGN, MANUFACTURE



**2 WORLD-WIDE**



*A.T.M. Products include:—*

Complete Strowger automatic telephone exchange equipment for networks of any size; Strowger automatic or key-controlled telephone equipment for private use; Electromatic vehicle-actuated road traffic control equipment; A.T.M. selective supervisory remote control, indicating and telemetering equipment for power networks; A.T.M. mine telephones and colliery signalling equipment; single and multi-channel (Carrier) transmission systems and associated apparatus; Rythmatic centralised ripple control equipment.

**ORGANISATION, DISTRIBUTION, APPLICATION**

**FIRST**—a modern telecommunications factory, containing the most scientific research equipment, machine tool, assembly, finishing and inspection departments. Within it are employed expert designers, technicians, and many thousands of highly-skilled workpeople.

**SECOND**—an organisation with many branches throughout the world which bring the knowledge and resources of the Company to all those seeking a solution to any telecommunication or light current signalling problem.

# **STROWGER TELECOMMUNICATIONS EQUIPMENT**

for all communities—large or small



**AUTOMATIC TELEPHONE & ELECTRIC CO. LTD.**

Regd. Office and Works:—Strowger Works, Liverpool, 7, England.  
Export Dept.:—Strowger House, Arundel Street, London, W.C.2. Cables: "Autelco, London."

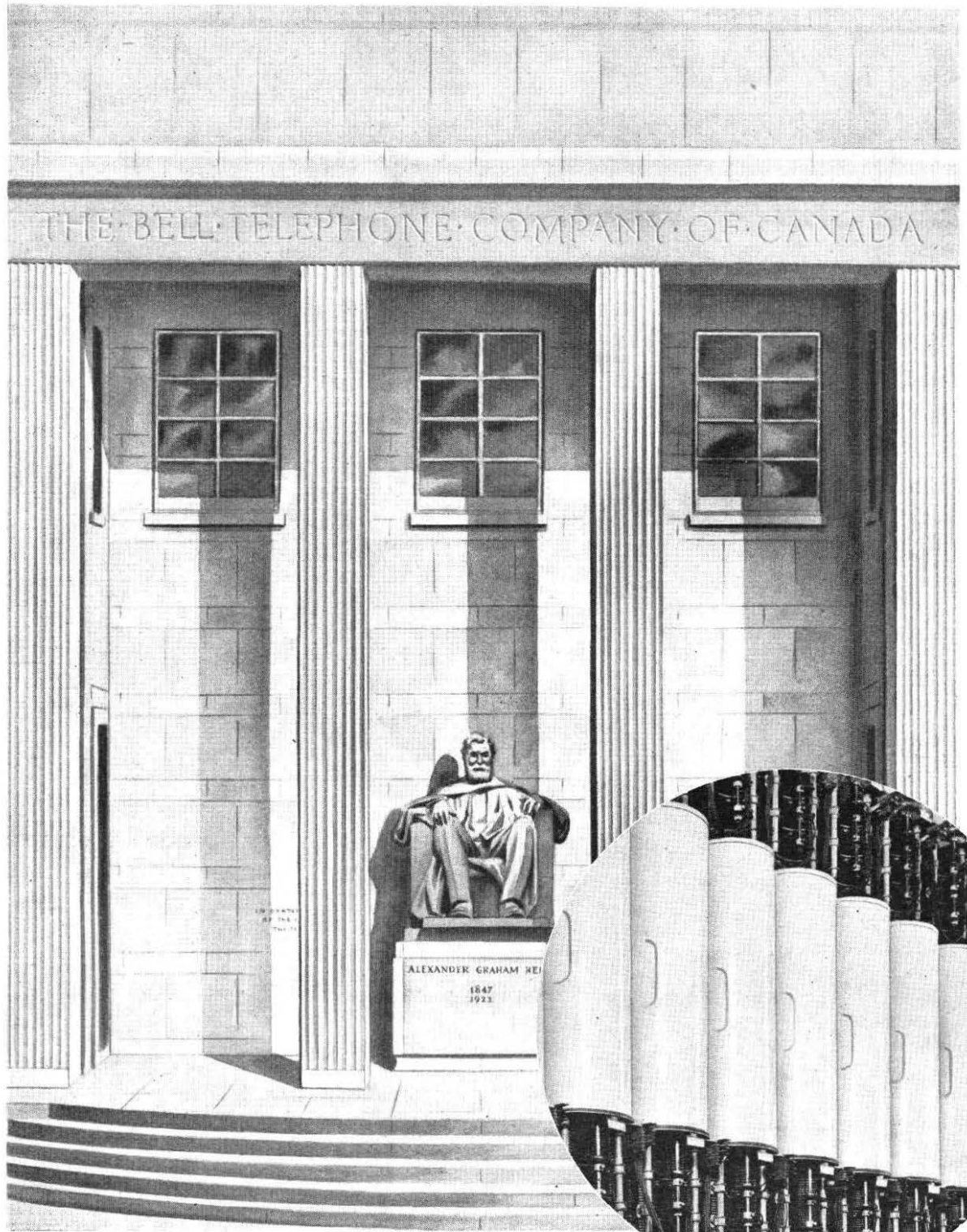

## "CANADA'S TELEPHONE CITY GOES DIAL"

**T**HROUGHOUT the years of the development of the telephone art, communication engineers everywhere have had a sentimental link with Brantford, Ontario, birthplace of the telephone and scene of the earliest work of the first pioneer Dr. Alexander Graham Bell.

It is fitting, therefore, that **Standard**, pioneers of the public telephone in Great Britain, were chosen to provide the first dial exchange in the "Telephone City".

Installation was carried out in association with the Northern Electric Company for the Bell Telephone Company of Canada in their new exchange building which forms the site of the recently unveiled memorial statue of Alexander Graham Bell.

This contribution to the country's export drive in hard currency areas is also a testimony to the quality and reputation of British Workmanship.

# **Standard Telephones and Cables Limited**

TELEPHONE DIVISION

Oakleigh Road, New Southgate, London, N.11

# SIEMENS

## VOICE-FREQUENCY DIALLING AND TANDEM SWITCHING EQUIPMENT

TOLL TO  
AUTO LINES

2-VF OSCILLATORS  
& INTERRUPTERS

2-VF RECEIVERS

INCOMING SELECTOR  
RELAY SETS

INCOMING SELECTOR  
SWITCHES

TEST PANEL

TRUNK LINE  
RELAY SETS

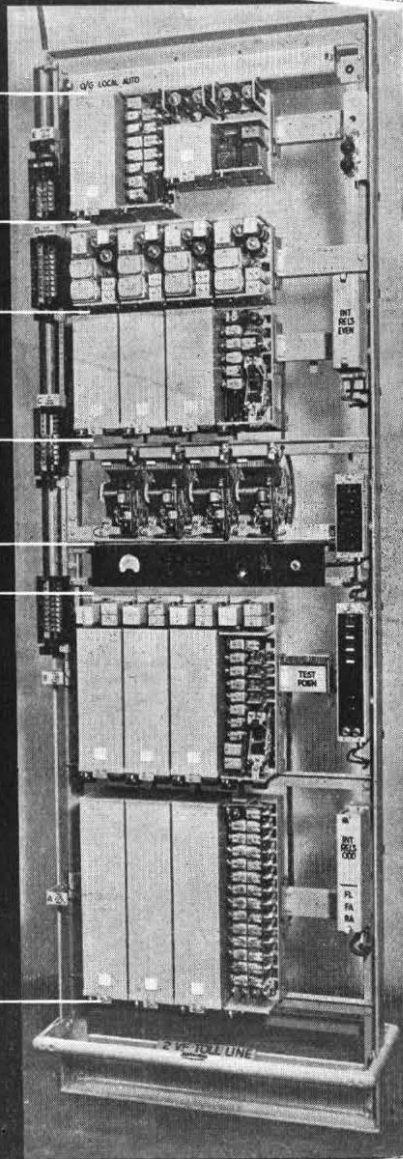

*for  
Canada*

THE illustration shows the advance equipment supplied by us for use at Calgary to effect tandem switching on long distance traffic between Red Deer and Winnipeg, prior to the installation of a complete Automatic Trunk Exchange at Winnipeg.

Facilities are provided for VF dialling, direct to auto subscribers, between Winnipeg, Calgary and Red Deer.

In addition to the Winnipeg equipment the Company has in course of manufacture Automatic Trunk Exchanges for Brandon (Manitoba), Edmonton (Alberta) and Halifax (Nova Scotia)

**SIEMENS BROTHERS & CO., LIMITED**  
WOOLWICH · LONDON · S. E. 18.



# MIGHTY midget . . .



The Ericsson **ALNICO** **GENERATOR** illustrated is a robust yet elegant example of Ericsson practice. Has an output equivalent to the old 4-Bar unit but is less than half its size and weight. Certified safe for use in mines, and can be supplied unmounted or without the moulded bakelite case. Our heavy duty **ALNICO** generator is slightly larger but uses the same case.

THE

**Ericsson**

**ALNICO GENERATOR**

# *A Typical Example of* **H.T.A. DESIGN**

Included in the range of H.T.A. Products are Telephone Coin Collectors, Stamp Selling Machines, Autodials, Commodity Vending Machines, Coin Operated Mechanisms, Kitchen Control Units, Gas Leak Indicators, Ticket Printing and Issuing Machines, also Coin Operated Totalisator Ticket Issuing Machines of which a model is illustrated here.

This machine is an independent ticket printing and issuing unit, constructed to operate on the insertion of a 2/- (two shilling) piece or other denomination of coin. Runner numbers can be varied from 1-99, which enables the machine to be used for both dog and horse betting.

The machine is portable and can, therefore, be moved from one track to another and run from power mains or portable accumulators.

It has two slots, one for "Win" bets and the other for "Place" bets. There are no buttons or other complications on the front of the machine: the public merely have to insert a coin.

The tickets are printed from plain rolls of paper and a warning light is shown when the roll reaches a predetermined minimum—diameter usually equivalent to 100 tickets.

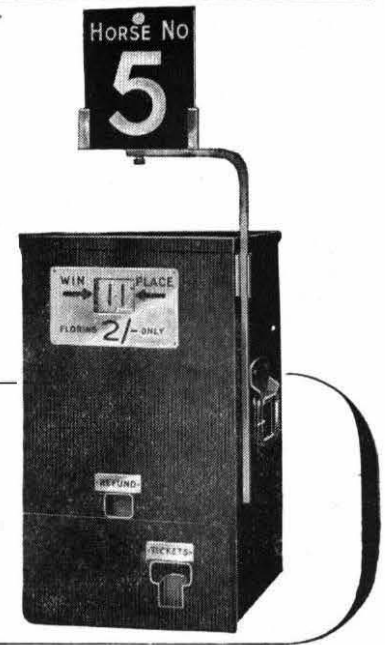

## **HALL TELEPHONE ACCESSORIES LTD**

*Precision Engineers & Instrument Makers*

**DUDDEN HILL LANE • WILLESDEN • LONDON • N. W. 10**

PHONE: WILLESDEN 5141

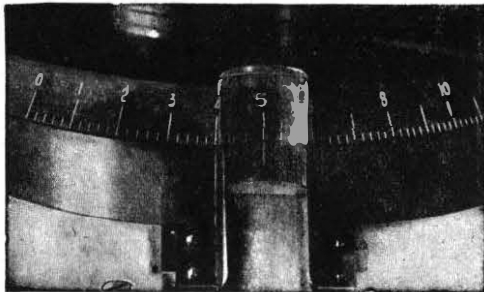

THE ACCURATE READING OF LOW CAPACITANCES ON A WIDE RANGE VARIABLE AIR CONDENSER, HAVING A CAPACITANCE RANGE 0 — 11,000 $\mu\mu$ F, IS ADMIRABLY SHOWN IN THE ABOVE ILLUSTRATION. THIS UNIQUE FACILITY CAN BE OPERATED ONLY ON:—

## **Electrical Standards for Research and Industry**

**Testing and Measuring Apparatus  
FOR COMMUNICATION  
ENGINEERING**

INVALUABLE AS GENERAL  
PURPOSE DIRECT READING  
BRIDGE STANDARDS  
OR AS BEAT FREQUENCY  
CALIBRATED CONDENSERS OF  
HETERODYNE OSCILLATORS

SULLIVAN-GRIFFITHS

WIDE RANGE

LOGARITHMIC

**VARIABLE CONDENSER STANDARDS**

**H. W. SULLIVAN  
LIMITED**

**LONDON, S.E.15**

Telephone: New Cross 3225 (P.B.X.)

FIFTEEN MODELS AVAILABLE COVERING THE  
FOLLOWING RANGES:—  
CAPACITANCE:

FROM 0 — 30 $\mu\mu$ F to 0 — 11,000 $\mu\mu$ F  
ACCURACY 0.01 $\mu\mu$ F or 0.1%

BEAT FREQUENCY:

FROM 0 — 1,200 c/s to 0 — 16,000 c/s  
ACCURACY 0.02 c/s or 0.2%

# POWER BEHIND THE LINES

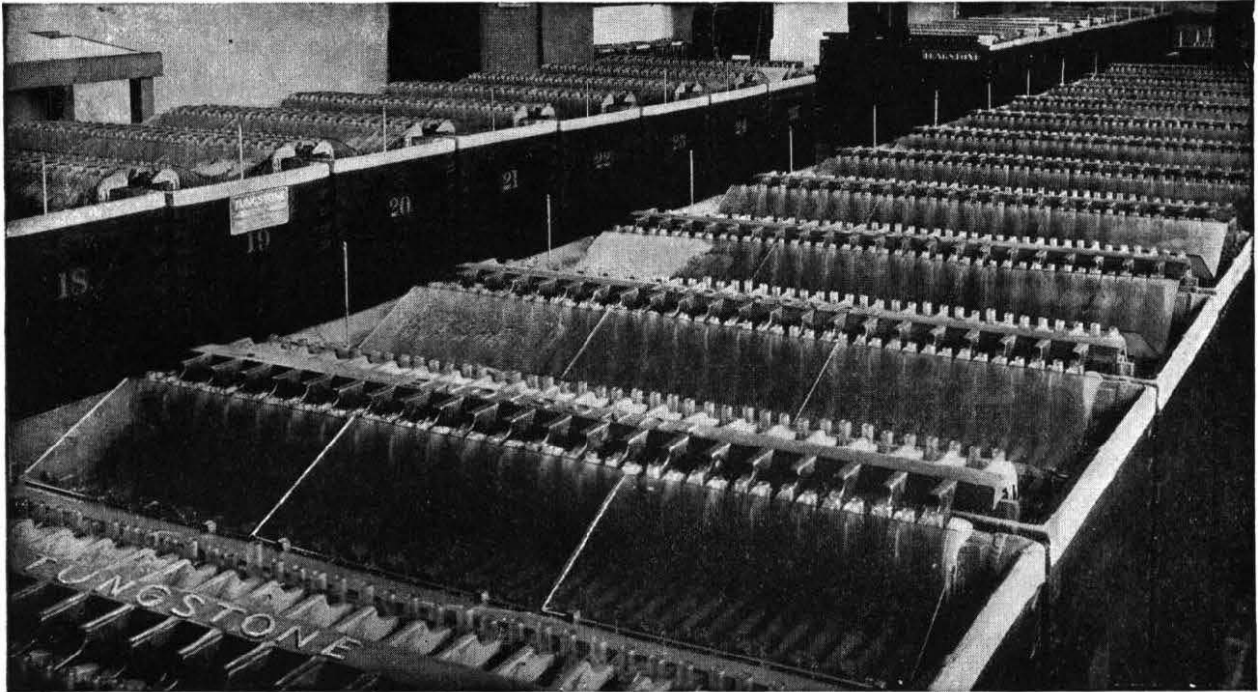

Tungstone Planté cells are being supplied to the British Post Office and to Posts and Telegraph departments abroad and conform fully to G.P.O. and *British Standard* specifications. Delivery is reasonable on all types and sizes.

#### *Open type cells*

Similar to the illustration above, these are available in glass and/or lead-lined wooden boxes, in capacities from 100 a.h. to 5000 a.h.

#### *Replatal*

We are in a position to supply plates for the replatal of any size of existing Planté batteries.

#### *Overseas Enquiries*

Export customers are invited to cable or write their enquiries for batteries or parts. Visitors to London are welcome at our offices.

#### *Enclosed cells*

Illustrated on the right, these are in sealed glass boxes, in capacities from 10 a.h. to 200 a.h., delivered in the U.K. filled and charged.

#### *Technical Service*

We are glad to advise on most suitable types and layouts for any installation and for any purpose.

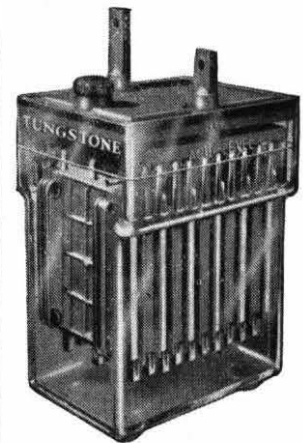

ENCLOSED TYPE CELL

## TUNGSTONE *Batteries*

For further particulars write: **TUNGSTONE PRODUCTS LIMITED,**

St. Bride's House, Salisbury Square, London, E.C.4. Telephone: CENTral 8156 (4 lines.).

Cables: DILUTUM, London Works: Market Harborough, Leicestershire.



# RECTIFIERS

for ALL PURPOSES

## TELEGRAPHY & TELEPHONY POWER SUPPLY

### DIRECT OPERATION

- Constant voltage rectifiers
- Teleprinter operation
- V.F. signalling
- Carrier telephony
- Amplifiers

### BATTERY CHARGING

- Single battery working
- Westat constant voltage chargers
- Constant current system
- Resonant relay control system
- Small magneto and C.B.S. exchanges
- P.B.X. systems
- Automatic telephone exchanges
- Portable chargers
- Repeater station equipment
- Two battery system

## TELEGRAPHY & TELEPHONY CIRCUIT APPLICATIONS

- Relay operation
- Rectifiers as variable impedances
- Measurements
- Rectifiers for use at radio frequency

## RADIO COMMUNICATION POWER SUPPLY

- H.T., L.T. and G.B. rectifiers
- Multi channel supply units

**WESTINGHOUSE**  
**WESTALITE**

# THE ALL-PURPOSE RECTIFIERS

Write for details to Dept. P.O.E.E.J.10

**WESTINGHOUSE BRAKE & SIGNAL CO. LTD.**  
82, York Way, King's Cross, London, N.1

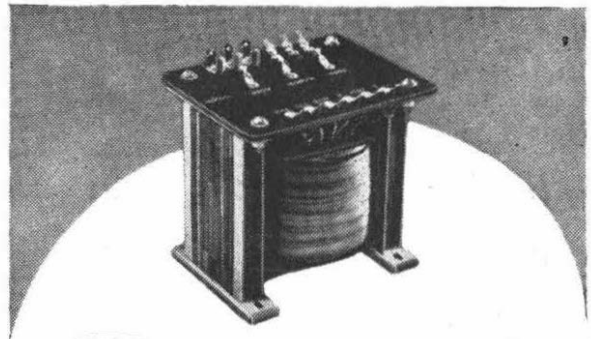

## When an unusual Specification is required.

We can give you the benefit of 20 years' experience in transformer construction and design. Whilst we manufacture quantities we do NOT mass produce. Every Instrument is built to suit your most exacting individual specification.

Send your enquiries for the personal attention of our Mr. W. Bryan Savage.



SAVAGE TRANSFORMERS LTD. ● NURSTED ROAD, DEVIZES, WILTS.

## A PRACTICAL PLAN for EARLY PROMOTION



Valuable Free Handbook Tells You How to Pass Your C. & G. or Promotion Exam. at First Attempt!

All Post Office Engineering personnel who are anxious to obtain early promotion should at once send for a copy of our handbook "ENGINEERING OPPORTUNITIES," which, among other intensely interesting matter, describes our unique methods of preparation for **TECHNICAL APPOINTMENTS IN THE POST OFFICE** (Assistant Engineer—New Style and Assistant Traffic Superintendent), **A.M.I.E.E., CITY AND GUILDS EXAMINATIONS** in Principles of Telecommunications (1-5), Radio (1-4), Telephone Exchange Systems (1-3), Telegraphy (1 and 2), Line Transmission (1 and 2), Lines Plant Practice (1 and 2), Mathematics for Telecommunications (1-5), Electrical Engineering Practice (Prelim. Inter. and Final), and outlines a wide range of non-examination courses in all branches of **Electrical, Mechanical, Civil, Automobile, Aeronautical and Radio Engineering.**

**We definitely guarantee "NO PASS—NO FEE"**

If you intend to make the most of to-day's opportunities, you cannot afford to miss reading "ENGINEERING OPPORTUNITIES." It tells you everything you want to know to secure advancement, and describes many opportunities you may now be missing through lack of information. Send for your copy to-day—**FREE** and without obligation.

**BRITISH INSTITUTE OF ENGINEERING TECHNOLOGY**  
369 SHAKESPEARE HOUSE,  
17-19 STRATFORD PLACE, LONDON, W.1

# BIET



## PRECISION CAPACITORS

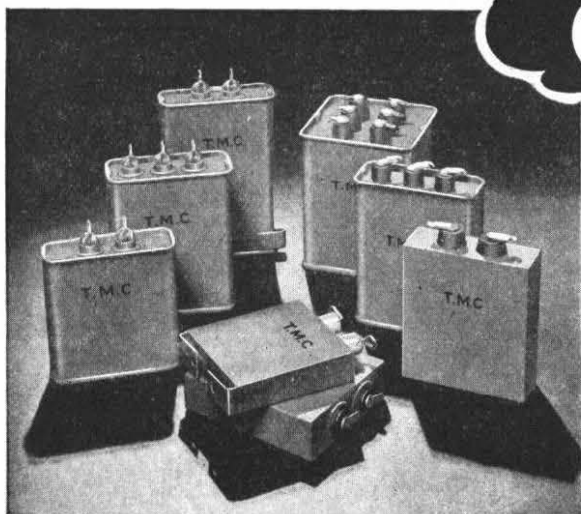

T.M.C. Capacitors for general use in Radio, Television, Electronic, Telecommunications, and Public Address equipment are made in a wide range of capacitances for working voltages up to 10,000 D.C.

Send for Descriptive Brochures F.1003 F. & K.

Engineers speak with no small pride when they say that their apparatus is to "Communications Standards."

We feel equal pride in the ever-increasing number of Engineers who specify their requirements from our comprehensive range of high grade "Precision" capacitors.

To Designers who must have the best we offer :—

### PAPER DIELECTRIC TYPES—

*for the not so exacting conditions.*

### CLAMPED MICA DIELECTRIC TYPES—

*for heavy current duty.*

### SILVERED MICA DIELECTRIC TYPES—

*for use where small size and weight are important.*

*Special types available for the most exacting temperature conditions.*

## TELEPHONE MANUFACTURING COMPANY LIMITED

Capacitor Dept., St. Mary Cray, Orpington, Kent. Telephone: Orpington 2650

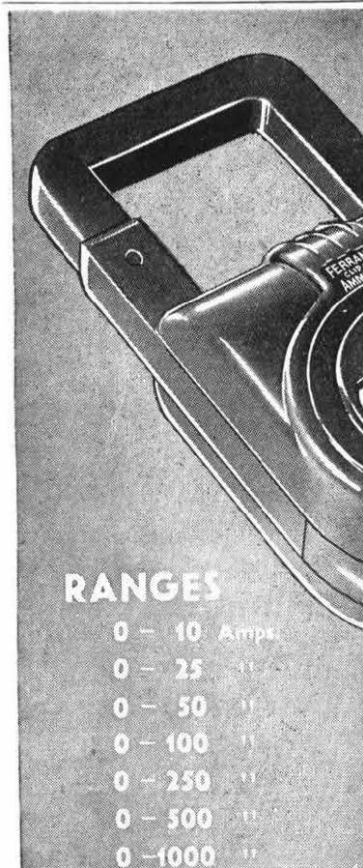

### RANGES

0 - 10 Amps.  
 0 - 25 "  
 0 - 50 "  
 0 - 100 "  
 0 - 250 "  
 0 - 500 "  
 0 - 1000 "

# FERRANTI

## 7-Range CLIP-ON AMMETER



Thumb-operated switch

Fully insulated

Accuracy within 3% of full scale

Can be applied to bare or insulated conductors up to 2¼ ins. diameter

Weight... 3 lbs.

Delivery from Stock

FERRANTI LTD., HOLLINWOOD, LANCs.

London Office: Kern House, Kingsway, W.C.2

**ELECTRICAL MEASURING  
INSTRUMENTS  
OF THE HIGHER GRADES**

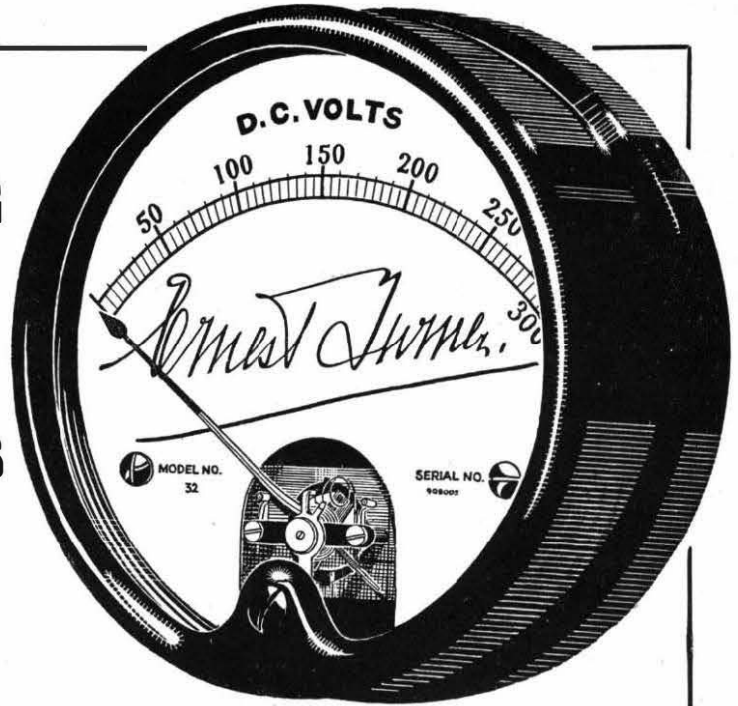

**ERNEST TURNER ELECTRICAL INSTRUMENTS LTD.**  
CHILTERN WORKS, TOTTERIDGE AVENUE, HIGH WYCOMBE, BUCKS.

Telephone: High Wycombe 1301/2

Telegrams : Gorgeous, High Wycombe

**THE INSTITUTION OF POST OFFICE ELECTRICAL ENGINEERS**

**PRINTED PAPERS**

The following papers contributed to the proceedings of the Institution have been printed by the authority of the Council and may be obtained, if still in print, from

**"THE LIBRARIAN, THE INSTITUTION OF POST OFFICE ELECTRICAL ENGINEERS, G.P.O. (ALDER HOUSE), LONDON, E.C.1."**

The prices do *not* include postage. Members, Associate Members, and Associates have the privilege of purchasing copies at two-thirds the stated price.

- |           |  |         |
|-----------|--|---------|
| No. 174.  | "METALLURGY AND COMMUNICATIONS."—E. V. WALKER, B.Sc., A.R.S.M. 1940  | 6d.     |
| No. 177.  | "RECENT APPLICATIONS OF THE QUARTZ AND X-RAY SPECTROGRAPHS TO POST OFFICE PROBLEMS."—R. TAYLOR, M.A., Ph.D., B.Sc. 1941                                    | 1s.     |
| No. 180.  | "SUBSCRIBERS' CABLE DISTRIBUTION—SOME FURTHER CONSIDERATIONS."—F. SUMMERS, A.M.I.E.E. 1944   | 1s.     |
| †No. 182. | "LONDON INLAND TRUNK SERVICES."—W. H. SCARBOROUGH, A.M.I.E.E. 1943   | 1s. 6d. |
| †No. 183. | "FREQUENCY MODULATION."—J. H. H. MERRIMAN, M.Sc., A.Inst.P., A.M.I.E.E., and R. W. WHITE, B.Sc., F.Inst.P., A.M.I.E.E. 1945                                | 1s. 6d. |
| †No. 184. | "THE FUNDAMENTALS OF DIRECT CURRENT IMPULSING IN MULTI-EXCHANGE AREAS."—S. WELCH, M.Sc.(Eng.), A.M.I.E.E. 1944   | 1s. 6d. |
| †No. 185. | "THE OPERATION OF VALVE OSCILLATORS AND THEIR SYNCHRONISATION."—A. C. LYNCH, M.A., J. R. TILLMAN, Ph.D., and D. G. TUCKER, Ph.D., A.M.I.E.E. 1944          | 1s.     |
| †No. 187. | "CABLING PROBLEMS IN SUBWAYS AND TUNNELS."—T. G. TURLEY, A.M.I.E.E. 1945   | 1s.     |
| No. 188.  | "POWER SUPPLIES FOR TELEGRAPHS."—G. N. DAVISON, B.Sc.(Eng.), D.I.C., A.M.I.E.E. 1945   | 1s. 6d. |
| †No. 189. | "DEVELOPMENT OF TELEGRAPH SWITCHING IN GREAT BRITAIN."—J. A. S. MARTIN, A.M.I.E.E., and J. W. FREEBODY, Whit. Schol., B.Sc.(Eng.), D.I.C., A.M.I.E.E. 1944 | 1s. 6d. |
| †No. 190. | "WIDEBAND TRANSMISSION OVER COAXIAL CABLES."—R. A. BROCKBANK, Ph.D., B.Sc., A.M.I.E.E., and C. F. FLOYD, M.A., A.M.I.E.E. 1946                             | 1s. 6d. |
| No. 191.  | "PIEZO-ELECTRIC QUARTZ AND ITS USE IN TELECOMMUNICATIONS."—C. F. BOOTH, M.I.E.E., and J. L. CREIGHTON, A.M.I.E.E.  | 1s. 6d. |

† The Council have awarded Institution Medals for these papers.

Take **YOUR** word for it

**“Denso**  
will be used  
exclusively”

An enlightening series of candid opinions of the efficacy of Denso Anti-corrosive and Sealing Products expressed by “Men on the Job.”

★ Report by a Cable Contractor dealing with the use of Denso for sealing cable ends:

★ “. . . Instructions have been received that in future Denso will be used exclusively for protecting cable ends and leaks. This will obviate carrying fires for melting bitumen — and should save valuable time.”

#### WHAT WE SAY

**DENSO TAPE**—a permanently plastic wrapping of open-weave textile impregnated and coated with a formula based upon a protective medium known through the centuries for its water and rust-proofing qualities.

**USRS**—Protects Services, Mains, Cables and Metalwork below and above ground against Chemical and Electrolytical corrosion and corrosive atmosphere.

Temporary repairs. Frost, Water and Gas-proofing. Sealing temporary cable joints.



Regd. Products

INDUSTRY'S SEAL AGAINST CORROSION  
Write for Specification and Price List

**WINN & COALES LTD.**

Terminal House, Grosvenor Gardens, London, S.W.1.  
Telephone: Sloane 6264 Telegrams: DENSELTE, SOWEST, LONDON

## SOUND INSTRUCTION by Postal Method

The I.C.S., largest school in the world devoted to spare-time training by the postal method, offers you highly specialised Courses for the following examinations:

**P.M.G. Certificates for Wireless Operators.  
C. & G. Electrical Engineering Practice, Installation and Telecommunications.  
Graduateship of the B.I.R.E.**

*I.C.S. Examination students are coached till successful.*

Other Courses meet the requirements of all who desire to qualify for responsible positions in Electric Power, Illumination, Heating and Traction Systems. Equally successful is our instruction for Telegraph and Radio Engineers, Radio Servicemen, and in Elementary Radar and Electronics, and Advanced Short-Wave Radio.

Instruction is by correspondence from textbooks specially prepared by many experts.

**WRITE FOR OUR BOOKLET “ELECTRICAL ENGINEERING”** and state the particular subject or Examination in which you are interested.

**YOU MAY USE THIS COUPON**

**International Correspondence Schools Ltd.**

Dept. 108, International Buildings, Kingsway, London, W.C.2

Please send me, free of charge, your special booklet on \_\_\_\_\_

Name \_\_\_\_\_ Age \_\_\_\_\_  
(BLOCK LETTERS, PLEASE)

Address \_\_\_\_\_



# PITMAN

## BOOKS

★ **A Useful Selection**

### METER ENGINEERING

By J. L. Ferns, B.Sc.(Hons.), M.I.E.E., A.M.C.T., A.M.I.I.A.  
Covers the theory, testing, installation and maintenance of electricity supply meters. With 194 illustrations. Fifth Edition 18/- net

“The meter engineer requiring a comprehensive textbook on every phase of his work—the principles, construction, design, installation and servicing of meters—cannot do better than secure a copy of this book.”—*Electrical Times*.

### PHOTOELECTRIC CELLS IN INDUSTRY

By R. C. Walker, B.Sc.(Lond.), A.M.I.Mech.E., A.M.I.E.E.  
A comprehensive treatise on the industrial uses of these cells. Profusely illustrated 40/- net.

### SWITCHGEAR HANDBOOK Vol. II

(Application)

Edited by W. A. Coates, M.I.E.E., Fel.A.I.E.E., and H. Pearce, B.Sc.(Eng.), M.I.E.E.; assisted by expert contributors. A revised reprint of this authoritative work, which provides a mass of information for users of switchgear, designers and students 30/- net.

### ELECTRICAL MEASUREMENTS AND MEASURING INSTRUMENTS

By E. W. Golding, M.Sc.Tech., A.M.I.E.E. A useful textbook covering the syllabuses of the B.Sc.(Eng.) and other examinations. Third Edition 25/- net.

### TELEPHONY Vol. I

By J. Atkinson, A.M.I.E.E., Area Engineer, Post Office Engineering Dept. The first volume of a completely revised edition of Herbert and Procter's great work, universally recognized as the standard guide to telephony. This volume deals with general principles and manual exchange systems, 694 illustrations 35/- net.

**SIR ISAAC PITMAN & SONS, LTD.,** Parker Street, Kingsway, London, W.C.2

# TELEPHONE CABLES

OUR BROCHURE No. 9E (1949),  
GIVING INFORMATION AND SPECI-  
FICATIONS FOR A WIDE RANGE  
OF TELECOMMUNICATION CABLES  
MANUFACTURED BY US, IS  
AVAILABLE UPON REQUEST.

TELEPHONE:  
SOUTHAMPTON  
2141 (5 lines).

**PIRELLI-GENERAL**  
CABLE WORKS, Ltd., SOUTHAMPTON.

TELEGRAMS  
-PIGEKAYBEL  
SOUTHAMPTON.

## DECADE SWITCH

A Precision Component Embodying  
All The Best Design Features

Very low contact resistance. Sturdy action.  
Positive location. Twelve positions—providing two extra contacts  
—30° angular spacing simplifies dial calibration.  
Two types available—416A (Shorting) and 416B  
(Non-Shorting).

PRICES ON APPLICATION

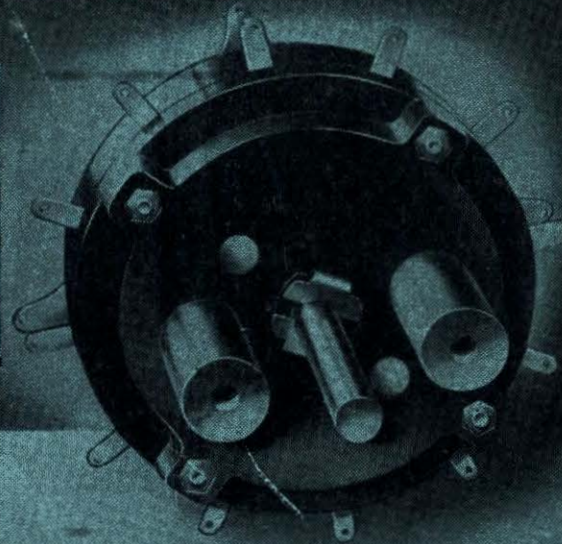

**G.E.C.**

**PRECISION CONTROLS** FOR COMMUNICATIONS & MEASURING EQUIPMENT

**SALFORD ELECTRICAL INSTRUMENTS LTD.**

PEEL WORKS SALFORD 3

Phone: BLA. 6688 (6 lines) Grams & Cables "Sparkless, Manchester"

Proprietors: **THE GENERAL ELECTRIC CO. LTD.** England