

# THE POST OFFICE ELECTRICAL ENGINEERS' JOURNAL

**VOL. 41**

**OCTOBER 1948**

**PART 3**

## CONTENTS

	PAGE
CRIGGION RADIO STATION—A. Cook, B.Sc., A.M.I.E.E., and L. L. Hall, A.I.E.E., A.I.R.E. . . . .	123
STANDARD FREQUENCY TRANSMISSIONS IN GREAT BRITAIN	129
DUCT RODDING WITH A CONTINUOUS ROD—R. Goford, A.M.I.E.E., and N. K. Bass . . . . .	130
RENOVATION OF TELEPHONE SWITCHBOARD SECTIONS—A. C. Hales, B.Sc., E. H. Brown and D. Harrison . . . . .	134
H.M.T.S. "ALERT" ; EX-GERMAN CABLESHIP "NORDERNEY"	138
SHARED SERVICE—C. J. Cameron, A.M.I.E.E., and W. A. Humphries, A.M.I.E.E. . . . .	139
REORGANISATION OF POST OFFICE RESEARCH . . . . .	147
A MULTI-CHANNEL RADIO TELEGRAPH EQUIPMENT—G. N. Davison, B.Sc.(Eng.), D.I.C., A.M.I.E.E., and R. J. Pickard, B.Sc.(Eng.), Grad.I.E.E. . . . .	148
C.C.I.(F.) MEETING, STOCKHOLM, JUNE 1948 . . . . .	154
FIFTH PLENARY MEETING OF THE C.C.I.R., STOCKHOLM, JULY 1948 . . . . .	155
TELECOMMUNICATIONS FOR THE 1948 OLYMPIC GAMES—E. R. Smith, A.M.I.E.E., and C. W. Sallnow . . . . .	157
CENTRALISED FIRE CONTROL SWITCHBOARD FOR LONDON FIRE BRIGADE—W. T. Wooding, A.M.I.E.E. . . . .	163
A HIGHLY-SELECTIVE TRANSMISSION MEASURING EQUIPMENT FOR 12- AND 24-CHANNEL CARRIER SYSTEMS—D. G. Tucker, D.Sc., Ph.D., and J. Garlick, B.Sc. . . . .	166
NOTES AND COMMENTS . . . . .	170
HEADQUARTERS NOTES . . . . .	171
REGIONAL NOTES . . . . .	175
STAFF CHANGES . . . . .	180
INSTITUTION OF POST OFFICE ELECTRICAL ENGINEERS . . . . .	182
BOOK REVIEWS . . . . .	133, 169, 170

Price 1/6 net

**THE INSTITUTION OF POST OFFICE ELECTRICAL ENGINEERS**

## DECADE SWITCH

*A Precision Component Embodying  
All The Best Design Features*

Very low contact resistance. Sturdy action.  
Positive location. Twelve positions - providing two extra contacts  
—30° angular spacing simplifies dial calibration.  
Two types available—416A (Shorting) and 416B  
(Non-Shorting).

PRICES ON APPLICATION

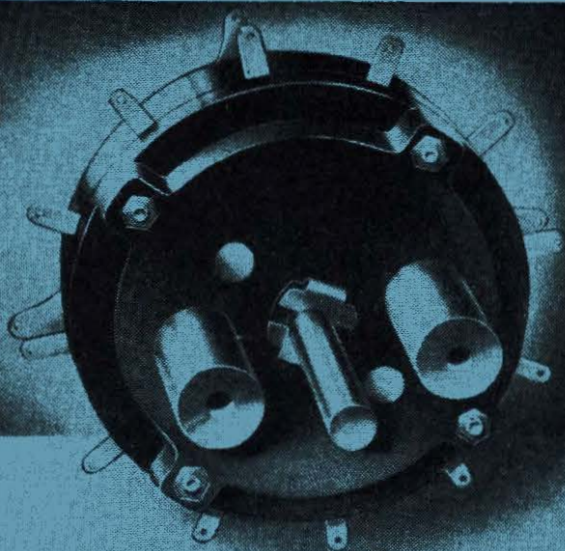

# G.E.C.

**PRECISION CONTROLS** FOR COMMUNICATIONS & MEASURING EQUIPMENT

**SALFORD ELECTRICAL INSTRUMENTS LTD.**  
PEEL WORKS SALFORD 3  
Phone: BLA. 6688 (6 lines) Grams & Cables "Sparkless, Manchester"  
Proprietors: **THE GENERAL ELECTRIC CO. LTD.** England

# EDISWAN

## TELEPHONE LINE PROTECTORS.

FOR THE PROTECTION OF LINES OF COMMUNICATION  
FROM SURGES INDUCED BY LIGHTNING OR FAULTS  
ON NEIGHBOURING POWER LINES.

Ediswan Telephone Line Protectors have now been in commission  
for nearly twenty years. They have proved their worth in all parts  
of the world and are being called for and installed in ever  
increasing numbers.

Many thousands were employed during the war years for the protec-  
tion of vital lines of communication and were eminently successful.  
Reports of their outstanding merit and successful operation  
continue to reach us and in recent years they have proved of  
particular interest for protection against surges caused by  
lightning discharges.

Continued research has enabled us to patent a further improve-  
ment which removes any suggestion of delay in operation.

*Further information and prices on application.*

**THE EDISON SWAN ELECTRIC CO., LTD.**  
155 CHARING CROSS ROAD, LONDON, W.C.2

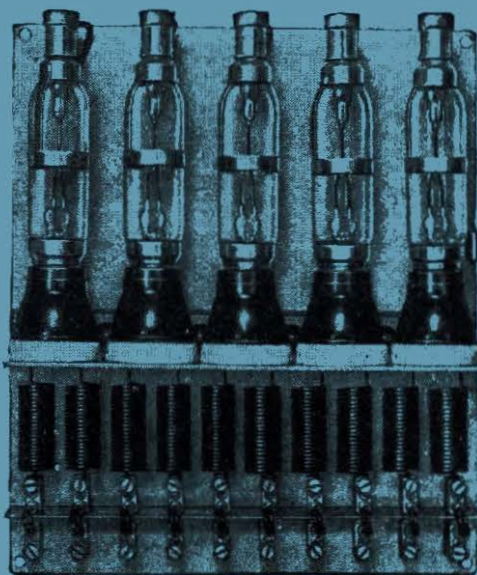

Prov. Patent  
25850/45.

5-circuit  
panel for  
overhead  
lines incor-  
porating  
choke  
coils, spark  
gaps, etc.

T.H.2

# THE POST OFFICE ELECTRICAL ENGINEERS' JOURNAL

Vol. 41

October, 1948

Part 3

## Criggon Radio Station

U.D.C. 621.396.7

A. COOK, B.Sc., A.M.I.E.E.  
and L. L. HALL, A.I.E.E., A.I.R.E.

Criggon radio station was built during the war to provide primarily an alternative V.L.F. transmitter to maintain essential services in the event of damage to the P.O. radio station at Rugby; H.F. and L.F. transmitters were also provided subsequently which, together with the V.L.F. transmitter, were used mainly for single-channel telegraphy services. This article outlines the planning and equipping of the station.

### Introduction.

IN view of the vital importance in wartime of the service given by the high-power, very low frequency telegraph transmitter at Rugby (GBR 16 kc/s), urgent consideration was given in the summer of 1940 to the establishment of a reserve station which could carry on the service in the event of damage to GBR. The first essential for a V.L.F. transmitter is an extensive aerial system supported as high above the earth as possible, and as no suitable structures were available for the support of the aerial system, and new structures could not have been made quickly enough, contour maps of an area which was considered to be as safe as possible from enemy action were inspected in an endeavour to discover two or more steep-sided mountains, from the summits of which an aerial could be suspended. A satisfactory solution to the project appeared difficult to realise, but at this stage three 600-ft. self-supporting steel towers were made available to the Post Office. By themselves these structures were inadequate for the support of a V.L.F. aerial as large as was considered necessary, and a site was sought whereon a high cliff or steep hillside bordered a plain so that the masts could be erected on the plain in a line parallel to the cliff and a large aerial could be suspended between the masts and the cliff. In addition to this prime requirement, it was also desirable that adequate power and cooling water supplies should be available, general transport facilities and a town of reasonable size should exist at no great distance from the site, and the provision of land lines over alternative routes to London should not entail undue expenditure of material and time.

After further search, a site at Criggon (about 15 miles west of Shrewsbury) was discovered which fulfilled the aforementioned requirements as well as could be hoped. A plan of the site as developed later is shown in Fig. 1. The site is generally flat, Breidden Hill rising 800 ft. steeply from the plain on the east side, and the River Severn bordering the plain on the west side. A road (Back Lane) passes through the site, rail facilities exist four miles away and an 11-kV power line crossed the site. At this stage interest was mainly confined to the portion of the site lying between Back Lane and Breidden Hill.

Initial enquiries elicited the information that the site was subject to rather serious flooding by the River Severn, the level of which varies by 20 ft. at

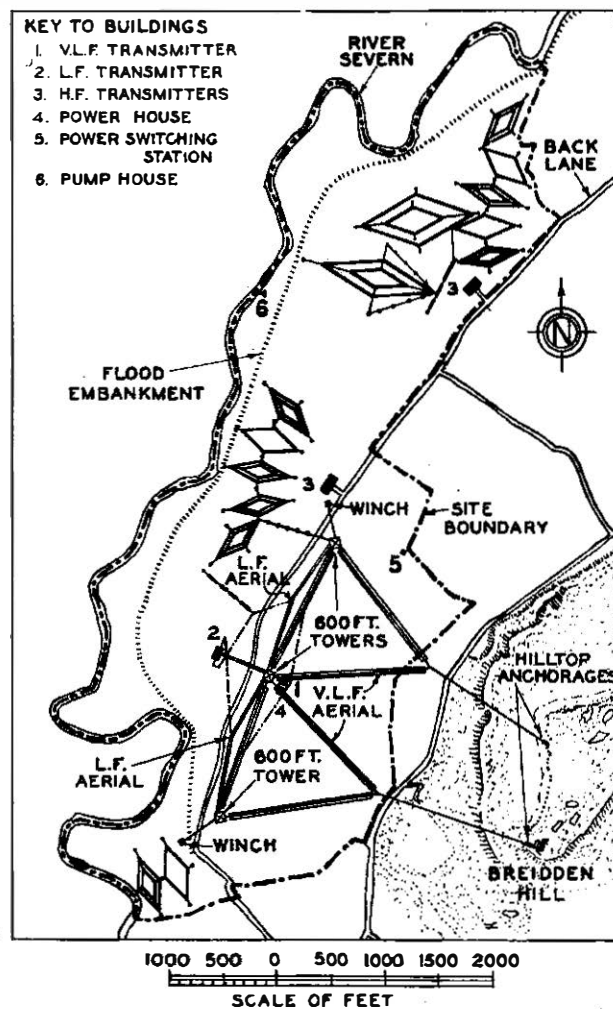

FIG. 1.—PLAN OF SITE.

this part of its course. The normal river level is some 15 ft. below site level, but when in flood the river is

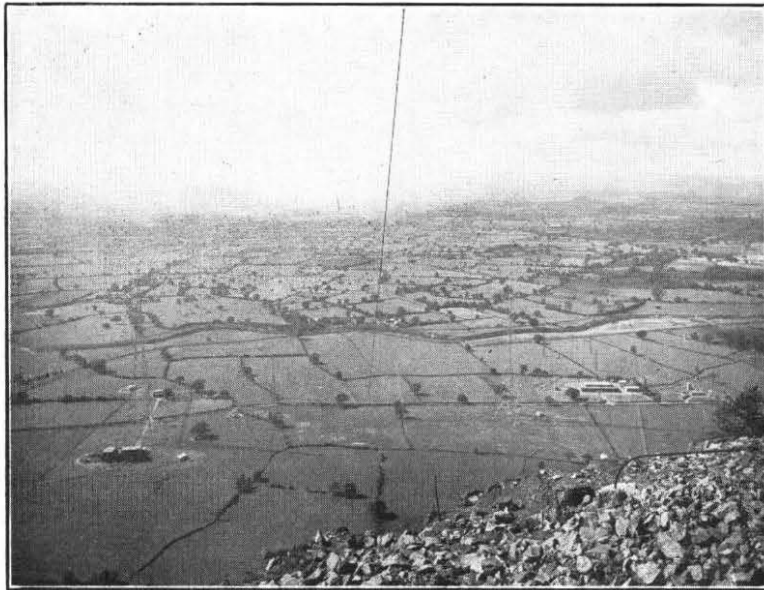

FIG. 2.—VIEW OF SITE FROM A HILLTOP ANCHORAGE.

constrained by embankments 8 to 10 ft. high. These have, on occasions, been overtopped and broken, and when the Rivers Severn and Vyrnyw rise simultaneously the flood waters spread back over the site from the confluence of the rivers, which is only four miles away. It was obvious that the floor levels of any buildings and all apparatus which would suffer damage by flooding would have to be kept at least 3 ft. above general site level, i.e. above the worst flood level which might be expected. During abnormal floods in the last few years<sup>1</sup>, the water has reached within a few inches of floor level in some buildings.

#### General Design and Layout.

In the design of the V.L.F. aerial, apart from the prime necessity of obtaining the largest top which it was possible to suspend between the hilltop and the three 600-ft. masts, consideration had to be given to the safety of the aerial from the effects of enemy action. As far as the aerial was concerned, the effects of damage to any of the supporting structures or part of the aerial itself would be minimised by adopting a multi-unit form, so that part of the complete aerial could be damaged and by some repair or modification the service could still be carried on the remainder.

No such measures could be adopted, however, with the transmitter, and some consideration was given to the possibility of installing it in an excavation in the hillside. If the aerial tuning coils had been located in the hill with the transmitter, the excavation into the solid rock (Dolerite) of the hill, would have taken a long time and the aerial up-leads would have been in close

<sup>1</sup>P.O.E.E.J., Vol. 40, p. 37.

proximity to the hillside, which it was feared would have resulted in a considerable loss of effective height and efficiency. Alternatively, locating the tuning coils out on the plain to keep the aerial up-leads as remote as possible from the hillside would have resulted in relatively difficult feeding arrangements and exposure of the coils to the danger of enemy action. It was decided, in order to get the quickest provision, to take the risk of installing the transmitter and tuning coils in a special building out on the plain. The building can be seen on the left of Fig. 2 at the foot of the middle 600-ft. tower. (An H.F. transmitter building is visible on the right, and the black line in the centre of the illustration is one of the hilltop halyards).

The aerial top consists of 8-wire "sausages" (as adopted for the GBR aerial at Rugby<sup>2</sup>) arranged in the shape of two equilateral triangles of 1,400 ft.

side, supported at an average height of 560 ft. between the three masts and two hilltop anchorages. This was the largest aerial that could be suspended from the available supports without undue sacrifice of height, and the capacity achieved by this form of construction is nearly as great as with a complete roof aerial. The design of the aerial was also influenced by maintenance considerations, and a scale model of the site, hill and aerial system was made to ensure that the aerial could be raised and lowered without fouling the hillside or obstructing the road along the foot of the hill. A general view of the aerial system with Breidden Hill on the right is shown in Fig. 3.

<sup>2</sup>Hollinghurst, F., and Mann, H. F. "Replacement of the Main Aerial System at Rugby Radio Station," P.O.E.E.J., Vol. 33, p. 22.

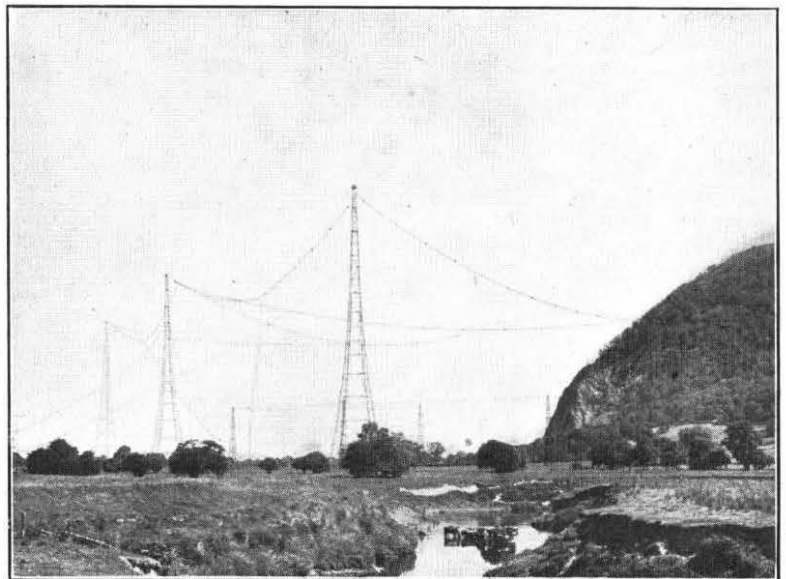

FIG. 3.—VIEW OF AERIAL SYSTEM.

The best position for the transmitter building was obviously on the axis of symmetry of the aerial, and twin up-leads had to be connected to the aerial top at the mid-points of the bases of the triangles so that the up-leads were kept as far from the masts as was practicable. The calculated capacitance of the aerial was 25,000 pF and, for tuning to a frequency of 16 kc/s, an inductance of 4 mH was required. Low-loss aerial tuning and intermediate circuit coils of the type used at Rugby<sup>3, 4</sup> constructed of Litzendraht cable (6,561 strands of 36 S.W.G. insulated copper wire) wound on wooden spiders up to 15 ft. diameter were designed, and when arranged for adequate spacing between the aerial tuning inductance and intermediate circuit coils required a room space of 55 ft. × 30 ft. × 32½ ft. high.

The circumstances of the provision of the transmitter did not permit of any development work being done and the design had essentially to be a copy of GBR, except for the incorporation of newer type components where available. To accommodate the transmitter, which consists of a crystal oscillator in duplicate, a low-power amplifier, an exciter (2 kW and 20 kW amplifier stages in separate enclosures) and the high-power stage (two panels each with 18 valves), power switchgear control table, etc., a room 55 ft. × 27 ft. × 15 ft. high was required.

The apparatus layout in the building is indicated in Fig. 4.

Since the building had to be proof against blast and incendiary bombs, the walls had to be thick and a considerable amount of steel was required in the roof. Special screening arrangements were therefore necessary to avoid losses in the building materials due to the magnetic fields surrounding the inductance coils, and a special form of lead-out for the aerial which would be safer from the effects of blast and splinters than that at Rugby (the insulation there being provided mainly by a large plate glass window) was designed for the V.L.F. aerial system. An extensive earth system consisting of about 50 miles of copper wire ploughed into the ground was also required, since the resistance of the earth system is the major component of the overall aerial circuit resistance, and every endeavour has to be made to minimise it.

The power required for the transmitter was 400 kW, and as the sole existing 11-kV line was controlled from Oswestry, 16 miles away, a locally generated reserve of power was desirable. The only engine generators available at that time were two 120-kVA

sets and a separate building was designed to accommodate these, together with water-cooling plant for the cooling of the transmitter valves. It was considered at that time that as the transmitter was for emergency purposes only and a pipeline from the Severn would be very vulnerable, local air-blast coolers were the safest and most economic proposition.

In late 1940 and early 1941 requirements for several H.F. services and two L.F. services arose and these radically altered the scope of the station planning. At that time it was impossible to foresee all the services which might be required, so plans were made to provide 12 transmitters and a number of aperiodic aerials for fairly wide geographical coverage so that services could be operated at short notice on any frequency between 4 and 22 Mc/s to any part of the world to which such services were likely to be required. The shape of the site and the proximity of Breidden Hill necessitated the layout of the aerial system in two main groups. Therefore, to minimise the lengths of the transmission lines and disperse equipment, it was decided to provide two buildings, half a mile apart, each designed to accommodate six 60-kW transmitters.

Satisfactory L.F. aerials could be suspended from the 600-ft. masts only, so to reduce coupling between the V.L.F. and L.F. aerials, avoid interfering with

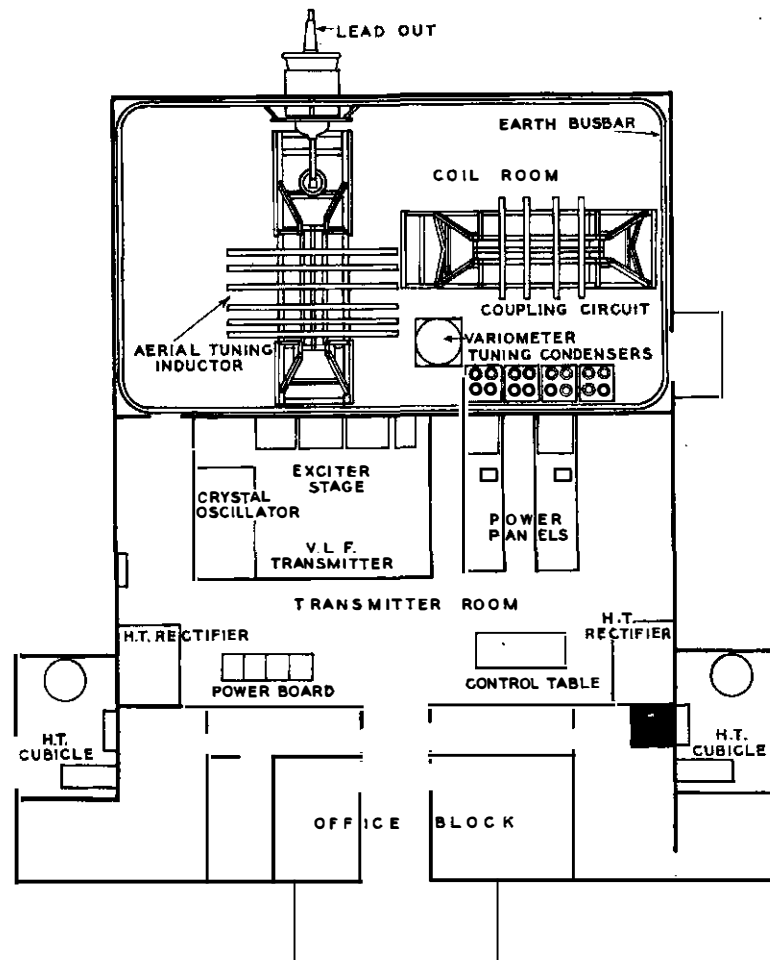

FIG. 4.—LAYOUT OF V.L.F. TRANSMITTER BUILDING.

<sup>3</sup>Shaughnessy, E. H. "The Rugby Radio Station of the B.P.O." *J.I.E.E.*, Vol. 64, p. 683.

<sup>4</sup>Hansford, R. V., and Faulkner, H. "Some Notes on Design Details of a High Power Telegraphic Transmitter using Thermionic Valves." *J.I.E.E.*, Vol. 65, p. 297.

the V.L.F. building and to disperse apparatus on the site, the building for the L.F. transmitters was located by the middle 600-ft. mast but on the opposite side to the V.L.F. building. One L.F. aerial could thus be suspended in each main mast span, and led down to the building as far from the structures and V.L.F. aerial as practicable. The arrangement of L.F. aeri- als between the 600-ft. masts and below the V.L.F. aeri- als can be seen in Fig. 2.

The supply of power then became a larger problem, for the estimated maximum demand rose from 400 to 1,000 kVA. The original 11-kV line which supplied Newtown from the substation at Oswestry ran across the site with a spur line to a quarry at Breidden Hill; the regulation of this line was not very good and without modification the line was incapable of carry- ing the additional load of the radio station. It was therefore necessary to raise the operating voltage to 33 kV and reroute the line clear of the radio station. The supply to the radio station was required at 11 kV and had to be distributed to the four transmitter buildings by a circumferential H.V. feeder from a switching station. To allow for damage to any section of the feeder, power could be fed either way round the feeder. The two 120-kVA engine sets were now totally inadequate to meet the station demand, but fortunately a 1,000-kVA engine generator set became available, so the plans of the power house adjacent to the V.L.F. building were revised to allow for the accommodation of this new set and its auxiliary gear<sup>5</sup>.

#### PLANT DETAILS AND CONSTRUCTION.

##### *V.L.F. Aerial System.*

Trial holes excavated by the Ministry of Works to determine the sub-soil conditions revealed that the earth consisted of a compact silt for a depth of several feet and the bearing capacity of this was perfectly satisfactory for the buildings. The foundations of the 600-ft. masts when designed in the normal way for firm earth conditions would have been approximately 10 ft. square at a depth of 8 ft. for each of the tower legs, so trial borings were commenced to greater depths. At a depth of about 12 ft. it was found that the compact silt changed to a soft grey-blue clay, and although the boring was continued to about 90 ft., no firm stratum was encountered; from the geological survey it was then found that this clay, which is a glacial drift, probably extends down to about 300 ft. Since no more than 1 in. of non-planar differential settlement of the foundations could be tolerated the foundations of the masts had to be piled. The piles had to be dependent upon the adhesion of the soil and not upon termination in a firm bed for their stability. For each leg of each tower 12 vertical piles 18 in. in diameter and varying from 60 to 93 ft. in length, and eight shorter

raking piles, were driven by the West Piling Co. using the Rotinoff method. The groups of piles were capped with concrete and the four cappings for a mast were connected by reinforced concrete tie bars. Measurement of foundation settlement over three years has shown a maximum sinkage in one case of approximately 3 mm. and a maximum rise of  $\frac{1}{2}$  mm., the worst non-planar differential movement for any one tower being less than 1 mm.

The towers were erected by Callender's Cable & Construction Co., the first tower being completed by September, 1942, and the others by the following March. By this time the hilltop anchorages and the construction of the V.L.F. aerial had been completed and the aerial was raised by a tractor and tackle, the final halyard load in calm weather being about 9 tons. Power-driven winches fitted with tension-limiting gear, in a previous description of which<sup>6</sup> reference was made to aerial load conditions, were ultimately provided. The masts were fitted with aircraft obstruction lights at the 200-ft., 400-ft. and 600-ft. levels, the power being conveyed by Pyrotanax cable.

##### *V.L.F. Transmitter.*

To expedite provision of the transmitter, part of which is illustrated in Fig. 5, two panels comprising the final stage and equipment for the exciter were transferred from Rugby, where they were not immediately required. Major changes from the design of the Rugby transmitter are the substitution of quartz crystal oscillators for the tuning fork drives and the elimination of motor generator sets for priming the valves. Two crystal oscillators are provided, one working and one standby, their stability being  $\pm 1 \times 10^{-7}$  over a period of one to four months. D.C. supplies are obtained from rectifiers, and as much of the oil-filled apparatus as possible is housed in external cubicles to minimise the fire risk. Incidentally, the

<sup>6</sup>Hall, L. L., and Watt-Carter, D. E. "Tension Limiting Gear for a Power Driven Winch," *P.O.E.E.J.*, Vol. 40, p. 86

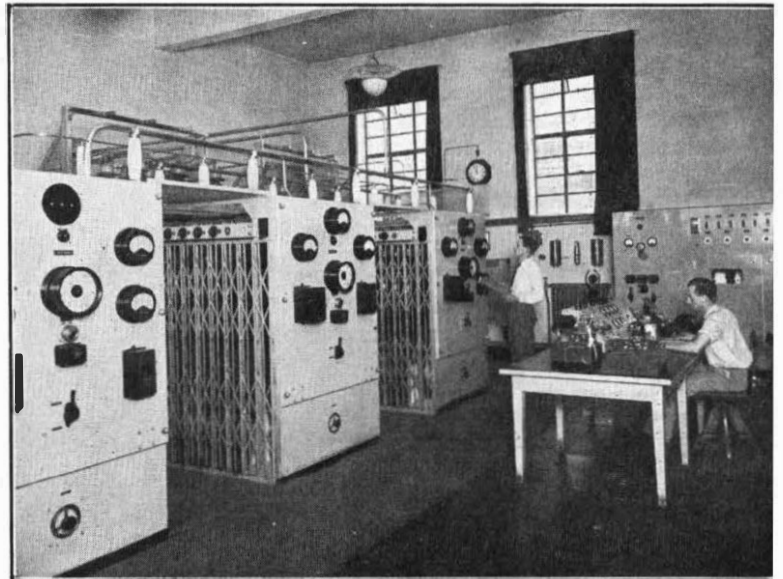

FIG. 5.—HIGH-POWER AMPLIFIER STAGE OF V.L.F. TRANSMITTER.

<sup>5</sup>Hall, L. L., and Rattue, P. J. "A 1,000-kW Diesel Generating Installation." *P.O.E.E.J.*, Vol. 37, p. 75.

effects of fire in the inductance room would be so great that special smoke-detection apparatus, developed by the Research Branch and working on the photo-electric principle, has been installed. Special precautions were taken in the control circuits of the

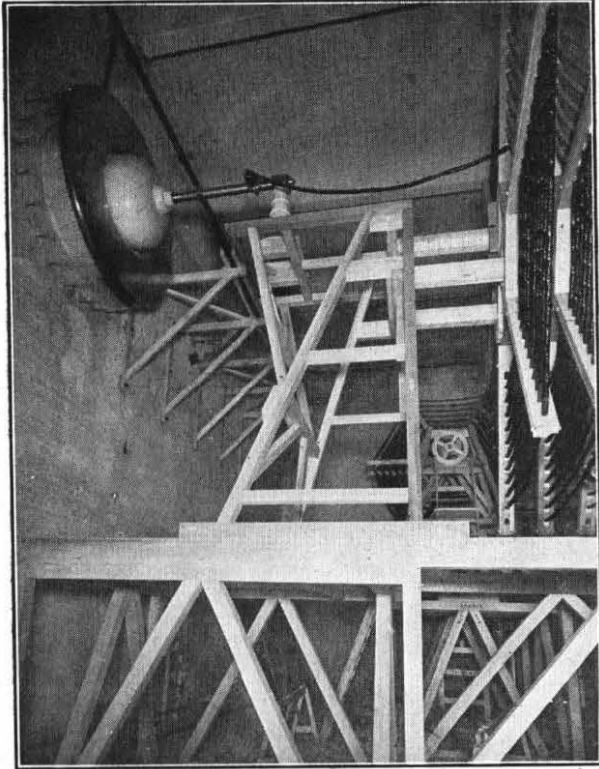

FIG. 6.—H.V. LEAD-OUT.

transmitter to ensure safety of personnel and apparatus.

The H.V. lead-out (the indoor end of which is seen in Fig. 6) consists of a horizontal torpedo-shaped copper conductor, approximately 1 ft. in diameter, supported concentrically within a tubular outer conductor 6 ft. long and 3 ft. 6 in. diameter, by a dome-shaped insulator. This outer conductor is held by a reinforced concrete tube built into the wall and acts as an electrostatic screen. The reinforcement of the concrete tube is electromagnetically screened by a number of copper wires passing through the walls and joining the inside and outside ends of the tubular conductor. The dome insulator is fixed to the indoor end of the reinforced concrete tube.

Flashover is likely to occur between the inner and outer conductors when the aerial current exceeds about 400 amps, which corresponds to a peak voltage of 220 kV. Prior to the design of this lead-out, a power-type H.V. bushing was tested but it was found that the loss at 16 kc/s was intolerably high.

The V.L.F. transmitter was completed and undergoing tests when a fire at Rugby Radio Station put GBR out of action on the 30th March, 1943. The testing was therefore hastened and the Criggion transmitter took over the service on the 2nd April; subsequently the frequency of the Criggion transmitter was changed to 14.46 kc/s and the call-sign GBZ allocated to it.

#### L.F. Equipment.

The first of the L.F. transmitters was installed in January, 1943, and the second in July, 1943. No. 1 is a CW telegraphy transmitter comprising a triode master oscillator and a signalling stage followed by two stages of Class C amplification and is capable of operating on any frequency between 40 and 150 kc/s with a power input at the final stage of 40 kW. No. 2 is a Marconi telegraphy transmitter type TFL76/1A which gives a maximum power output to the aerial of 40 kW on any frequency of 40 to 150 kc/s. One aerial is provided for each transmitter and these are suspended from the 450-ft. levels of the 600-ft. masts. The up-leads are 6-in. diameter cages and the tops 2 ft. diameter cages. The up-leads are anchored at the building on poles, and small versions of the V.L.F. lead-out are employed for leading out of the building. The R.F. field is sufficient to cause burning of the pole tops and it was found necessary to screen the poles with a cage of copper wire. The earth systems are similar to, but smaller than, that for the V.L.F. system.

#### H.F. Equipments.

The two buildings housing the H.F. transmitters are similar in design and a plan showing the layout of apparatus is shown in Fig. 7. The transmitter room

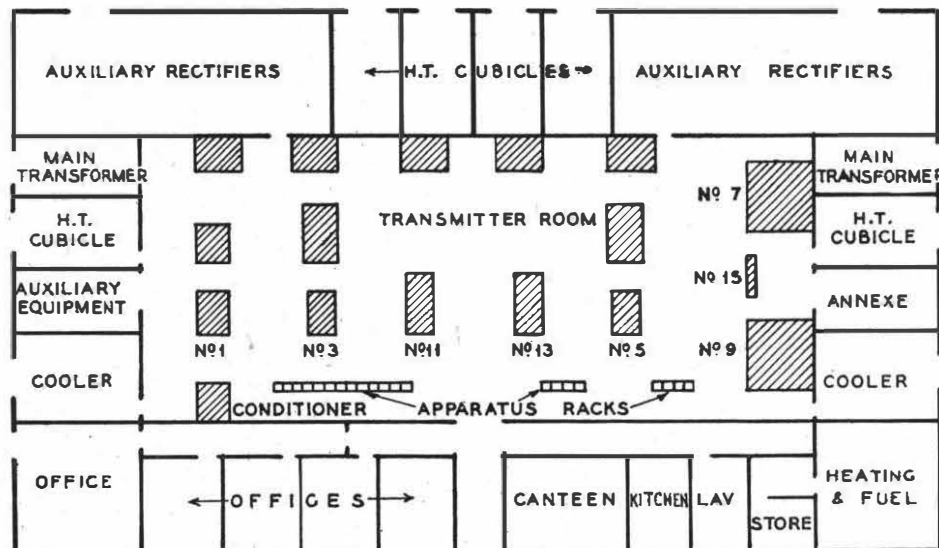

FIG. 7.—LAYOUT OF H.F. TRANSMITTER BUILDING.

measures 110 ft. × 47 ft., and is 5 ft. 7 in. greater in height than the rest of the block. High-level windows at the back of the transmitter room are used for lead-outs for the aerial transmission lines. The cubicles surrounding the transmitter room are laid out so that common equipments for the building, i.e. coolers, main power transformers and switchgear are installed in duplicate, one at each end of the building, in order to reduce the risk of damage to any part putting all the transmitters out of action. The buildings were designed to accommodate six of the latest type of Post Office high-power transmitters, but the actual provision, dictated by subsequent circumstances, is somewhat different. In Fig. 7, Nos. 1, 3, 11, 13 and 5 are Post Office transmitters, Nos. 7 and 9 Standard Telephones & Cables transmitters (Types CS3B and CS5B) and No. 15 a Western Electric transmitter Type "D" 156000. Transmitter No. 1 is a telegraphy transmitter contained in two separate frameworks, one housing the amplifier stages and harmonic generators to the penultimate (20 kW input) stage and the other the final (120 kW maximum D.C. input) stage of two demountable valves Type 43 with pumping equipment. Transmitters 3 and 5 differ from No. 1 in that the final stage is of 200 kW maximum D.C. input using two demountable valves Type 45. Transmitters, Nos. 11 and 13 are of lower power, approximately 40 kW, and are intended essentially for single-sideband working (SSB) for which service they develop a peak envelope power output of 30 kW.

Rack-mounted equipment comprising land line terminating and testing equipment, amplifiers, crystal oscillators with distribution panels for feeding the output by coaxial cable to the harmonic generator stage of any of the transmitters, SSB drive and monitoring receiving units is installed near the wall on either side of the entrance door to the transmitter room. The transmission lines from the aerials are terminated on the high-level windows opposite the transmitters and connection is made between the transmitters and lines by plug-and-socket connectors. Some extra flexibility of connection is provided by internal lines run along the length of the building near the windows.

It was originally proposed that the aerial system should consist of a number of Koomans arrays suspended on 180-ft. steel towers. During planning, however, investigations into the performance of rhombic aerials for transmitting indicated that although the gain and width of beam vary with wavelength, the salient features of aperiodicity and ease of construction and maintenance justified the use of rhombic aerials instead of Koomans arrays, at least for this emergency station which was planned for general rather than specific services. The layout of the aerial system as installed is shown in Fig. 1, and two of the aerials can be seen in Fig. 2, supported between the small lattice masts and poles. To maintain geographical coverage on all frequencies, the rhombic aerials were erected in pairs, one being half the size of, and suspended within, the other. Some omni-directional dipole aerials are also provided for emergency services.

#### *Water-Cooling System.*

At the time when the cooling system for the station was planned, it was not known how many high power transmitters would, in fact, be installed in each H.F. building, so the system was therefore designed to cater for the full complement. The cooling plant in each building is provided in duplicate at opposite ends of the building and consists essentially of heat exchangers, pumps and motors for distilled water circulation and storage and reservoir tanks. The heat dissipated by the radio valves into the distilled water is transferred in the heat exchangers to the river water. The collection and pumping of river water is done at the pumphouse (Fig. 8) on the river

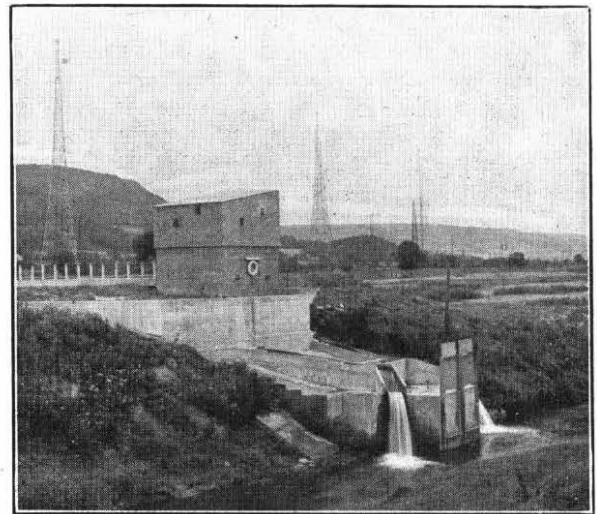

FIG. 8.—THE PUMPHOUSE.

bank at a point equidistant from both H.F. buildings. As the variation in height of the river is about 20 ft. at this point, the pumps are sunk some 4 ft. below low-water level and the pump chamber consists of a vertical watertight shaft 11 ft. square with pumps and valves installed at the bottom, but operated by motors and controls at the upper floor level which is 1 ft. above high-water level. The whole under-water system of intake chamber settling pipes, sumps, screens and pumps is in duplicate to enable maintenance to be given to one part while the other is in use. Each of the two pumps is capable of delivering 800 gallons per minute against a head of 40 ft. and can thus serve both H.F. buildings simultaneously. The return flow from the heat exchangers empties into the river through open channels at the pumphouse.

#### *Power System.*

The circumferential feeder serves six substations, one each at the V.L.F. and L.F. buildings and two each at the H.F. buildings. Complete control of the main and standby power is centred in the power house, where remote operation and indication of the incoming circuit breaker at the mains switching station is provided. The switch at the power house controlling the circuit breaker in the switching station is inter-



locked with the alternator circuit breaker and bus section switch in such a manner that any two, but only two, of the three switches can be closed at one time. Thus the whole station may be served from the mains or from the alternator, or the V.L.F. transmitter load may be taken on the alternator and the rest of the station on the mains.

*Land Line Equipments.*

The normal control of the transmitters was exercised from London and land lines were provided by alternative cable routes to the station. The V.L.F., L.F. and four H.F. transmitters were used exclusively for single-channel telegraph signals, but the remainder of the H.F. transmitters were likely to be used for single-channel telegraph services, multi-channel telegraph services or speech transmissions. To meet the telegraph requirements an 18-channel V.F. system was installed, equipment for 9 channels being in each of the H.F. transmitter buildings. Fifteen of the channels were used as transmitter controls and three as bothway order wires. Two 4-channel V.F. systems were also installed (one in each building) with a view to setting up controls from centres remote from London should the need arise. For the speech signals racks of terminal repeaters, equalised to 6,000 c/s, were provided.

*Conclusion.*

The Criggion Radio Station was started to provide an essential wartime reserve on the Rugby transmitter GBR, and was extended to include valuable low- and high-frequency transmitters. It has been retained in full working order to meet some of the Admiralty and Post Office needs for radio transmitters. Since 1945, the Post Office has reintroduced all the radiotelephone services operated before 1939 (with the exception of direct service to Tokio) and in addition opened several new services. The number of circuits to Australia, Canada, Cairo, South Africa and the United States has also been increased, and multi-destination Press Services have been maintained on a considerable scale. The station at Criggion is now carrying an appreciable amount of civilian traffic.

*Acknowledgments.*

The planning and equipping of the Criggion Radio Station involved the Lines and Telegraph Branches of the Engineer-in-Chief's Office in addition to the Radio Branch. Much of the work was undertaken on behalf of the Admiralty. Acknowledgment is made of the co-operation of the Ministry of Works and various contractors and of the assistance given by the Welsh and Border Counties Region.

**Standard Frequency Transmissions in Great Britain**

The question of radiating standard frequency transmissions from Great Britain has recently been under consideration by a committee of the Department of Scientific and Industrial Research representing all Government Departments concerned, including the General Post Office. Such transmissions are of great value in connection with the calibration of industrial and scientific frequency sub-standards, with work on radio wave propagation,<sup>1</sup> and also for survey purposes. Standard frequency transmissions of guaranteed accuracy are at present emitted from station WWV of the U.S.A. National Bureau of Standards<sup>2</sup> on frequencies of 2.5, 5, 10, 15, 20, 25, 30 and 35 Mc/s, continuously. On account of propagation conditions it is often difficult to make use of any of these transmissions in Europe and farther east. At the International Telecommunications Union Conference (Atlantic City, 1947) it was agreed that the first six of these frequencies should be allocated on a world-wide basis for future standard frequency services. Hence, if interference between such services is to be avoided very careful co-ordination will be required.

In existing circumstances the provision in Great Britain of a comprehensive service will take some

considerable time, but arrangements are now being considered whereby a limited service on three frequencies will be operated by the General Post Office. Such a service should enable the degree of interference from and with the WWV service to be experimentally determined and also demonstrate the feasibility and value of United Kingdom and European coverage.

It may be of interest that the following United Kingdom transmitters are maintained at their nominal frequencies to a tolerance of better than  $\pm 1 \times 10^{-6}$ .

Station Call Sign	Nature of Service	Location	Nominal Frequency in kc/s
GBR	Telegraph	Rugby	16
—	Broadcast	Droitwich	200
GMT	Standard Frequency <sup>3</sup>	Royal Observatory, Abinger	2,000
GRO	Broadcast	Skelton	6,180
GSB	Broadcast	Daventry	9,510
GSV	Broadcast	Daventry	17,810

Many of the B.B.C. medium wave transmissions also maintain their nominal frequencies to a tolerance of approximately  $\pm 1 \times 10^{-6}$ .

<sup>1</sup>P.O.E.E.J., Vol. 43, p. 153.

<sup>2</sup>National Bureau of Standards (U.S.A.), Letter Circular LC 886, 30.1.48.

<sup>3</sup>Wireless World, Vol. 53, p. 439.

# Duct Rodding with a Continuous Rod

U.D.C. 621.315.29

R. GOFORD, A.M.I.E.E.,  
and N. K. BASS

Experiments in rodding with continuous 600-ft. lengths of steel rod are now in progress and this article describes the equipment used and technique employed.

## Introduction.

TO overcome wartime shortages, experimental rodding was conducted with a continuous length of steel wire. Poor results were obtained at first since the wire available was at best only that produced by "patenting" (a fairly high temperature heat treatment) and hard drawing, which only resulted in a work-hardened wire whose tensile strength was easily reduced to a low figure at points where the wire became stressed, for example, at kinks which developed at the duct mouth when feeding the wire in. Also, the wire was not sufficiently rigid and took a set in reeling.

It is now evident that success in rodding with a continuous length of wire or rod can be achieved only by the use of rod which is virtually straight. This necessitates a tensile strength of an order which can be obtained only by hardening and tempering a fairly high carbon steel and not by work hardening or patenting. No suitable material was available initially since the industry did not produce anything for the required purpose.

The function which the rod must fulfil is somewhat unusual and involves certain bending stresses in normal use. The rod has to be coiled for transport and handling and the largest convenient diameter of the coil for that purpose is about 4 ft. 6 in. In use the rod is likely to be bent and stressed to smaller radii. It is essential that after coiling and uncoiling many times and being subjected to some abuse, the rod should still remain virtually straight when laid out above the ground. This result has not been completely achieved but the experimental rod now in use and described later is quite capable of withstanding the coiling stress, and careful heat treatment of the rod should overcome the more severe stress resulting in kinking.

## Initial Experiments.

The first continuous rodding apparatus (not of British manufacture) comprised a 600-ft. length and a 300-ft. length of  $\frac{5}{8}$  in. diameter rod, each housed on a revolving reel within a framework. Initial results were good, particularly when rodding over existing cables, but the heat treatment the rod had received left much to be desired and after considerable use kinks formed at various points. Ultimately, so much resistance was set up that only relatively short distances could be rodded.

Further, the rod was weakened by the formation of flats at the kinks, and even when restraightened, did not stay in this state for long.

At this stage national conditions prevented further outfits being obtained from the original source and efforts were commenced to find a wire drawer willing to undertake production of a number of rod lengths for larger scale trials.

## Equipment used for Later Tests.

A manufacturer (John Rigby & Sons, Ltd.) was eventually found who was prepared to produce 600-ft. lengths of  $\frac{5}{8}$  in. heat-treated steel rod and an outline of the method adopted in heat treatment is shown in Fig. 1.

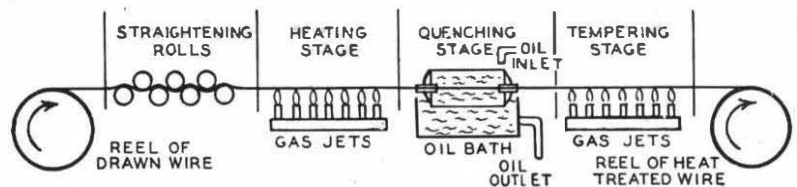

FIG. 1.—HEAT TREATMENT OF CONTINUOUS ROD.

The drawn rod is fed from a reel through straightening rolls, passed over a line of gas jets to obtain the necessary temperature for quenching, then through a continuously circulating oil bath for quenching purposes and finally over another series of jets to obtain the necessary tempering heat before being recoiled. Control is maintained by varying the speed of travel of the rod and the temperature of each series of jets.

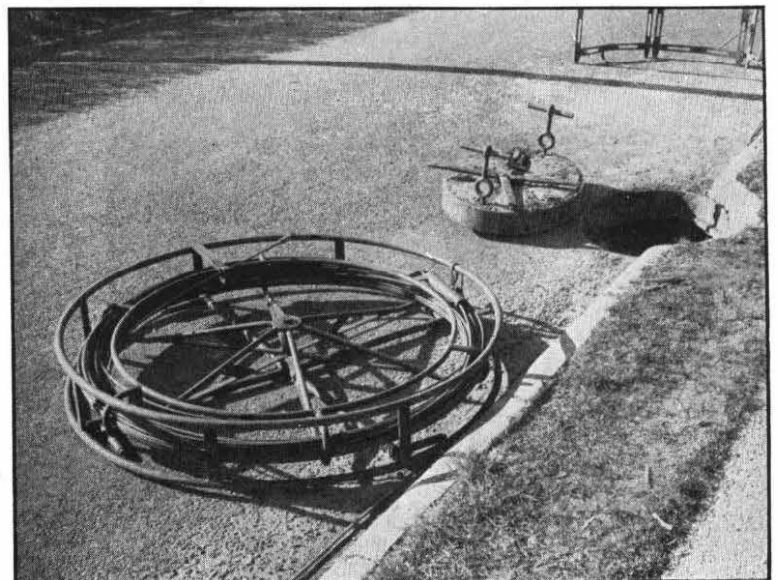

FIG. 2.—THE REEL OF ROD.

The steel used for the rods has the following analysis :—

Carbon content ..	0.70-0.75 per cent.
Silicon .. .. .	0.3 per cent. max.
Phosphorus .. .	0.05 per cent. max.
Sulphur .. .. .	0.05 per cent. max.
Manganese .. .	0.8 per cent.

It is recognised that the method as described, although effective in the hands of a skilled operator, does not afford such close control of temperature and quenching as is desirable and an alternative and much

mental reels were fitted with legs to raise them off the ground when used in a horizontal position, and with stands to allow operation in a vertical position. It was found, however, that a reel when so supported horizontally was liable to rock, and in the vertical position control was difficult. Such legs and stands are now omitted and the reel is always used horizontally.

The accessories provided with the rodding outfit are illustrated in Figs. 3, 4, 5 and 6, which indicate the use of the various adaptors. The hand grip shown is necessary when a sufficiently firm hold on the rod cannot be obtained by hand. This item will shortly be

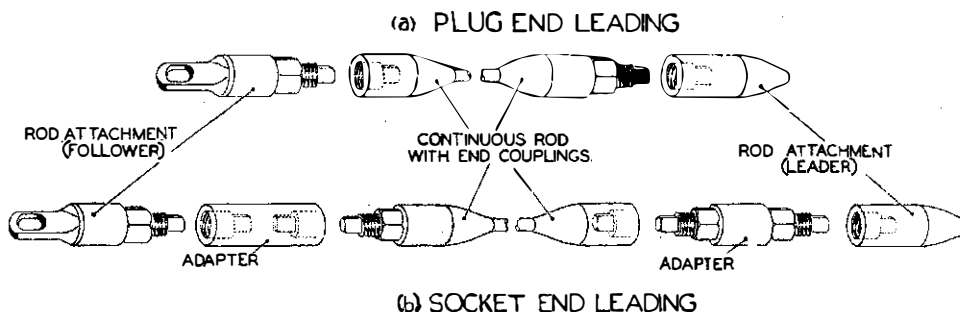

FIG. 3.—STRAIGHTFORWARD RODDING.

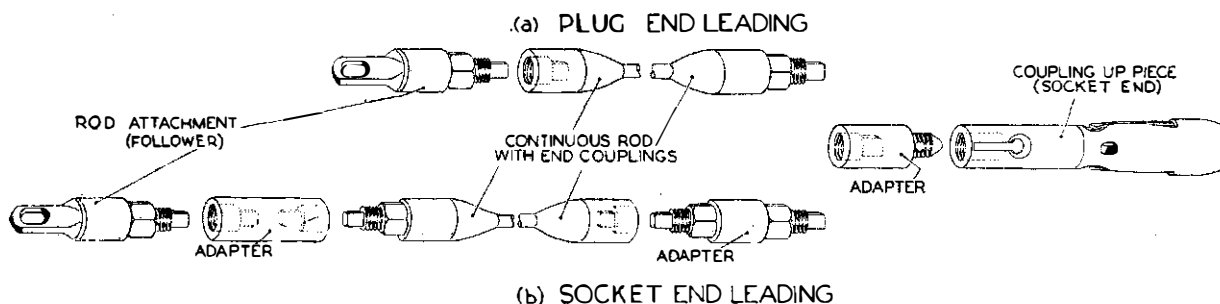

FIG. 4.—RODDING WITH SOCKET-END COUPLING-UP PIECE LEADING.

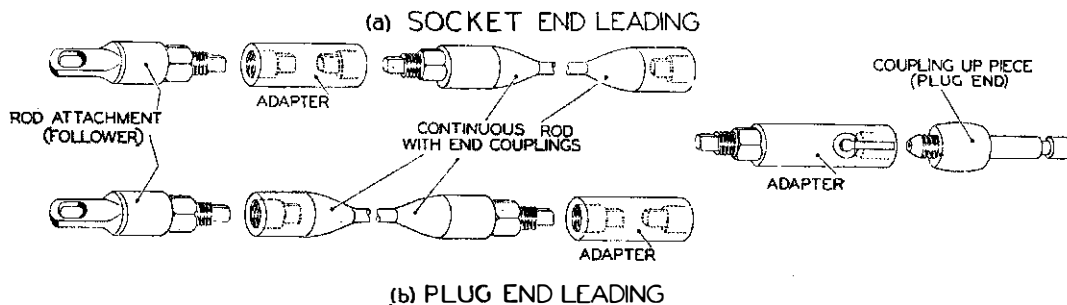

FIG. 5.—RODDING WITH PLUG-END COUPLING-UP PIECE LEADING.

superior plant ("Trauwood Process") has recently been installed by the manufacturer which should result in the production of rod with greatly improved properties.

Fig. 2 shows a reel containing a length of the continuous rod. The inner end is housed in a cup on the circumference of the reel on the stationary housing. The rod is reeled up by passing it through an eye. Straps are used to clamp both the stationary and rotating portions of the reel to give a rigid assembly when rolling from place to place. The early experi-

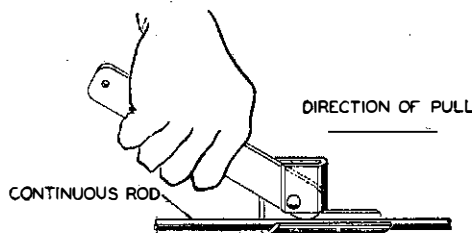

FIG. 6.—HAND GRIP.

superseded by an improved tool now being developed. In addition to the standard rodding outfit a gang should possess a small supply of ordinary sweeps' rods to permit connecting up in difficult cases and for use when rodding in short lengths where the use of a continuous rod would not be justified.

*Method of Use.*

Fig. 7 is illustrative of the method used when either



FIG. 7.—ROD IN USE.

pushing the rod into the duct or pulling it out. It is important to note that the two men should be as close as possible to each other with their hands near the duct mouth, since it is only here that the maximum pressure can be applied. One man is needed at the reel to control it and prevent it from jerking and whipping when a sudden pull or push is exerted.

When pulling the rod out of the duct, the pull should be exerted from immediately in front of the duct mouth. The pull required is considerably

increased if the rod bears on the edge of the duct mouth or on the edge of the box or manhole entrance. The reel should be placed as close to the edge of the hole as possible to avoid this. The man controlling the reel should count the number of revolutions so that the length of rod inserted may be calculated. A revolution counter on the reel may later be employed to determine the length of rod paid out.

Fig. 8 (a) shows how, when rodding through a manhole, it is possible to work with the rod passing across the chest. This is a very easy method to employ when possible and a very rapid performance may be set up. Rodding through a joint box may be carried out in a somewhat similar manner.

Fig. 8 (b) shows the method of using the hand-feeding grips which should be kept as close to the duct mouth as possible. They may also be used in withdrawing the rod with considerable advantage in certain circumstances. The grips are retained on the rod as it is fed into or out of the duct, the motion of the hands being sufficient to make them grip in a forward direction and slide in a backward direction.

*Organisation of Gang.*

Circumstances will decide the advisability of setting up rodding parties, but if a lot of rodding is to be carried out in empty duct this would undoubtedly be preferable since progress could then be planned. A three man party equipped with rodding apparatus and drawing-in wires or ropes ahead of the cabling gang would permit good progress. This would also be possible in occupied duct although the cabling gang would probably catch up with the rodding party when difficult duct sections were encountered. In such cases the two gangs could then join together and overcome the difficulty by opening up or by other means after which the rodding party would go ahead again

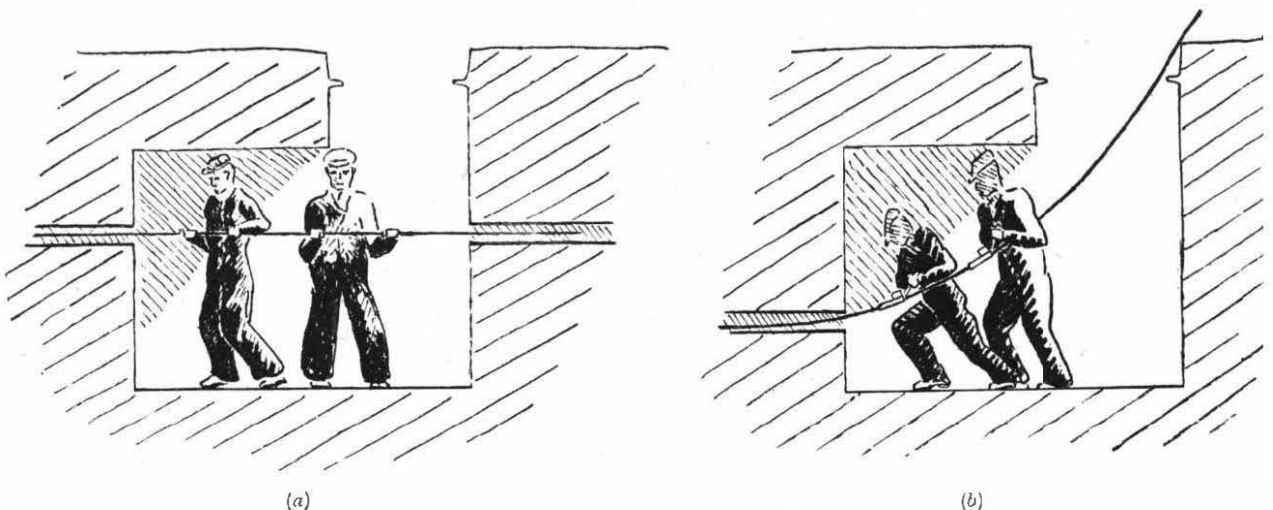

FIG. 8.—(a) RODDING THROUGH A MANHOLE. (b) RODDING WITH THE AID OF HAND-FEEDING GRIPS.

It is generally found that rodding is the most uncertain part of cabling work. If rodding goes well, the rods are idle for a large part of the gang's time, and if badly, some of the men are unoccupied for long periods while obstructions are overcome. In any event the time spent in assembly and taking apart of P.O. standard rods is avoided by using a continuous rod and if the work is suitably organised and the method of working thoroughly understood by gangs, familiarity with the new method and specialisation by the rodding party should lead to a considerable improvement over existing practice.

#### Practical Experience.

The results of the first trials of the equipment are summarised in Table I which has been compiled from reports submitted by various Regions. A more detailed and precise summary will be possible later.

#### Conclusion.

It has been established by shining a light along the duct from the duct mouth, that the continuous rod follows a spiral course and in view of the constant diameter of the continuous rod, and its freedom from intermediate couplings and irregularities, consistent performance in empty ducts should be obtained. In occupied ducts, however, the rod, in following the cable lay, will inevitably run into difficult points and try to burrow under the cables as do sweeps' rods. These factors are receiving attention and there is hope that the difficulties may be overcome. An important advantage of the continuous rod is that, because the

diameter is constant throughout its length, a machine drive becomes possible. A compact device for this purpose is at present being developed.

TABLE I

Type of Duct	Details of cables in Duct	Length rodded (yds.)	Distances rodded if marrying necessary (yds.)
3-in. S.A.D.	None	156	—
3-in. S.A.D.	None	190	—
3-in. S.A.D.	None	176	—
4-way M.D.	None	145	120+25 (Silted duct)
3-in. S.A.D.	3 cables. 50 pr., 74 pr., and 75 pr.	160	100+60
4-in. S.A.D.	2 cables. 74/20 and 160/20	178	100+78 (Bend in track)
3-way M.D.	3 cables. 38 pr/64, 4/40 and 80/120	180	160+20
3-in. C.I. pipe	3 cables. 150/10 100/10. 75/10	95	60+35
3-in. S.A.D.	1 cable 75/10	145	—
2-way M.D.	None	175	160+15
2-way M.D.	None	156	—
3-in. C.I. pipe	None	135	—

It is considered from the experience gained with continuous rods that further large-scale field trials are fully justified.

#### Acknowledgment.

Thanks are due to Messrs. J. Rigby & Sons for information supplied on the heat treatment of the rods.

## Book Review

"Frequency Modulation," Vol. 1. By Staff of R.C.A. Laboratories. Published by R.C.A. Review, Princeton, N.J., U.S.A. 515 pp. 307 ill. Price \$2.70, post free to U.K.

The preface to this book states that 'Volume 1 is the seventh volume in the R.C.A. Technical Book Series, and the first on the subject of F.M.', and that 'the papers in this volume cover the period 1936-1947.' The general format of this volume is thus similar to that of the preceding six volumes in that it consists of reprints of papers on frequency modulation published by members of the R.C.A. organisation during that period.

To those well versed in the art of V.H.F. communication, the book can be recommended as a convenient summarising reference volume on frequency modulation theory and practice. Unless the student reader is equipped with a very adequate knowledge of fundamental theory, he would be advised not to attempt to use it in the manner of a text-book, for the very reasons which apply to any summarising volume of this nature. This is particularly applicable to the field of frequency modulation in which development has been rapid during the period under review. It is thus not surprising to find incorrect conclusions quoted in some of the earlier papers, and amended by subsequent workers. For example, in the paper by Crosby on p. 85 it is concluded that distortion arising from multi-path propagation is greatest

'at the lower modulation frequencies,' whereas in the paper by Corrington on p. 274 the correct and antithetic result is given.

It is, however, refreshing to read a book titled "Frequency Modulation" and which contains, out of a total of some five hundred pages, but twenty allocated to V.H.F. aerial systems and none at all on V.H.F. propagation. These twenty pages can be forgiven when the magnitude of F.M. broadcasting in the U.S.A. is remembered, and the specialised aerial problems associated therewith visualised.

This volume can claim to be the first anthology of F.M. As such, it is contended that the paper by Giacometto, summarised on p. 84, ought to have been included in full, at the expense, say, of the omission of the paper on pp. 164-177, with its intriguing but uninformative photographs and the paper on p. 305 which has no special information on F.M. techniques. The arrangement of papers dealing with F.M. station coverage is at first sight illogical and a separate sub-section would have considerably aided reference.

It is considered that this volume is suitable and valuable as an anthology of F.M. development for specialist use but that its general usefulness is limited by the necessarily disjointed nature of its contents and its lack of, say, a critical commentary interlinking the various articles.

J. H. H. M.

# Renovation of Telephone Switchboard Sections

A. C. HALES, B.Sc.,  
E. H. BROWN and  
D. HARRISON  
(Factories Department)

U.D.C. 621.395.65

To assist in meeting present day demands for telephone service use is being made of manual switchboards of the C.B. No. 1 type recovered from old exchanges. In general the sections need to be completely dismantled, renovated and rebuilt to make them fit for reissue and this article describes the procedure set up by the Post Office Factories Department to handle the work involved.

## Introduction.

SECTIONS, Switch, C.B. No. 1 were introduced into telephone exchanges in this country in 1901. A section has a multiple capacity of 10,000 lines and comprises three operating positions, each with a maximum capacity of 17 cord circuits.

The Post Office Factories Department is familiar with the repair of these switchboards, as it has been responsible for renovations and modifications ever since the switchboard was introduced. It has been found desirable to centralise all work on these switchboards at the Birmingham factory because of the extreme lack of space at the London factory. As this type of switchboard is no longer purchased from the main telephone contractors, the Birmingham factory is now the sole source of supply. Renovations have, up till now, been specially designed for a particular telephone exchange and switchboards have been equipped to meet individual requirements. This has been necessary because the different manufacturers who have been responsible for equipping telephone exchanges have been allowed a certain amount of freedom in detail of manufacture of switchboards, provided the electrical performance was satisfactory. This has led to differences in physical dimensions between the switchboards in different exchanges and has necessitated individual "tailoring" so that the renovated switchboards will match those already in existence. With the need for rapid extension of the telephone service, and the necessity to replace telephone exchange equipment damaged during the war, the Post Office decided that temporary extensions to manual exchanges were necessary to tide over the period until new automatic exchanges could be built. Thus arose the need for the present programme of renovations.

To simplify the work, a series of specifications based on careful and detailed examination of a large number of existing switchboards, was prepared by the Engineering Department. This has enabled the factory to turn out a standard switchboard having certain important dimensions uniform, so that there is a good chance that switchboards supplied for an extension to an exchange will line up with the existing switchboards. The production of a standard switchboard has been achieved by ensuring that the heights of the keyshelves, plugshelves, multiple shelves and associated jackfields are the same, and by taking care that the depth of the switchboard (from front to back) is never less than an agreed minimum.

During the process of renovation, which will now be described, the old switchboards are stripped down

to the framework, which is rebuilt, fitted with the necessary woodwork, equipped and wired.

## Framework.

Frameworks are usually in a dilapidated condition when received in the factory and it is not unusual for much of a framework to be completely rebuilt, the work being done in the fitting shop. Old frames are not treated very kindly during transport and are often badly damaged. Where details (such as the keyshelves, stile bars and top frames) are not fitted in the correct position, they have to be completely reconstructed to meet the requirements of the specification. As far as possible all the old metal work is used again, but the amount of new material used in repair is considerable. Fig. 1 shows a typical framework as received in the factory.

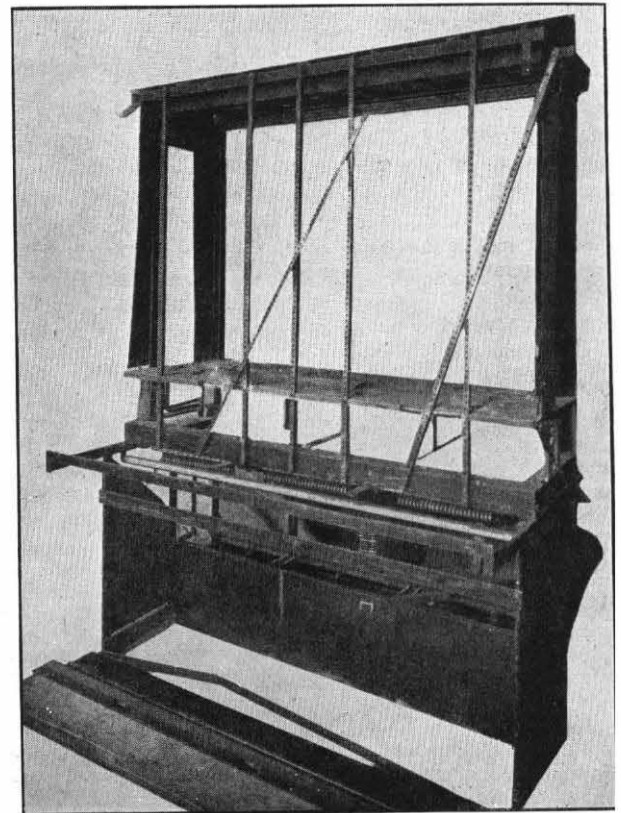

FIG. 1.—FRAMEWORK OF TYPICAL SECTION FOR RENOVATION.

The introduction of 3,000-type relays to replace obsolete types of relay, has necessitated fitting standard relay mountings which were not usually fitted

when the switch sections were new. These have had to be made in the factory owing to supply difficulties.

After the frameworks have been repaired, they are sent to the finishing shops, where dirt and grease are removed, and are then sprayed with grey enamel.

#### Woodwork.

When the framework has been enamelled, it is passed to the cabinet shop where all the necessary woodwork is made and fitted. Generally it has been found impracticable and uneconomical to repair any of the existing woodwork, but where there is no alteration in size needed, front and back covers are repaired and used again. It was customary until a few years ago to finish all woodwork by french polishing, but as this is a somewhat lengthy and costly process, it has been abandoned in favour of spray polishing. This gives a finish which is quite as attractive in appearance although less glossy and slightly less durable than a true french polish.

One of the more interesting operations carried out in the cabinet shop is the manufacture of new key-shelves

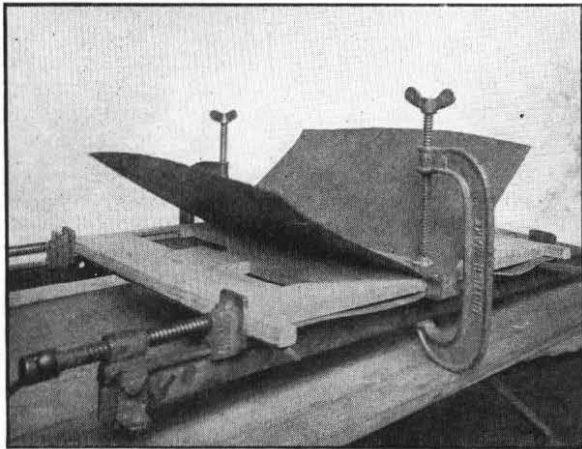

FIG. 2.—EARLY STAGE IN KEYSHELF MANUFACTURE.

and plug-shelves. It is the practice to make new key-shelves and plug-shelves for all renovated sections and the process is worth describing in detail. First a wooden frame is constructed of hard wood; mahogany is used wherever possible. This frame is finished to  $\frac{3}{4}$  in. thickness and is designed to have a space in the centre to accommodate the necessary number of keys. (This is more economical in the use of timber than a plain board with clamped ends which would require the centre to be cut away to accommodate the keys). The front of the frame is nosed, or rounded, and is then ready to receive the familiar red fibre.

A sheet of red fibre, cut to a suitable size, and the wood shelf are "toothed" (i.e. roughened to form a key for the glue). The fibre is then soaked in water, glued, and fitted to the nosing, after which the whole assembly is placed in a wooden frame, cramped up and allowed to dry (See Fig. 2, which shows a key-shelf in the cramp). The top and bottom are next glued (without being soaked in water), and a number of shelves are placed in a veneering press having heated

platens. When the glue has set and the shelves are dry, the holes for the lamp jacks, meter keys, etc., are drilled, all key apertures are finished to the correct

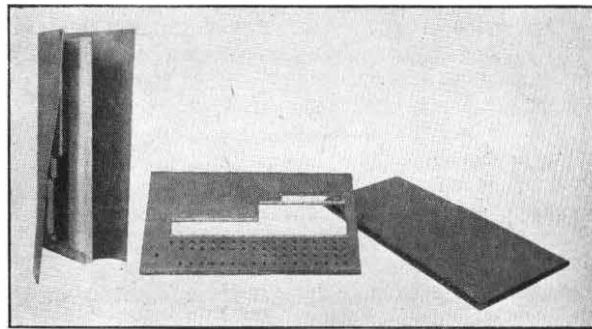

FIG. 3.—COMPLETED KEYSHELF.

size and the metal key mountings fitted. Fig. 3 shows on the left a keyshelf ready for the final gluing operation; on the right, the keyshelf is seen after removal from the veneering press, and in the centre it is shown completed and ready for fitting to the section. A  $\frac{1}{8}$  in. fibre fillet is fitted to the right-hand edge of the keyshelf which marks the dividing line between it and the next keyshelf. The surface is then carefully smoothed with sandpaper and the final finish is imparted with a good wax polish.

A similar procedure is adopted for the plug shelves, which are also faced with red fibre. These, however, are made up as plain boards and holes are drilled for

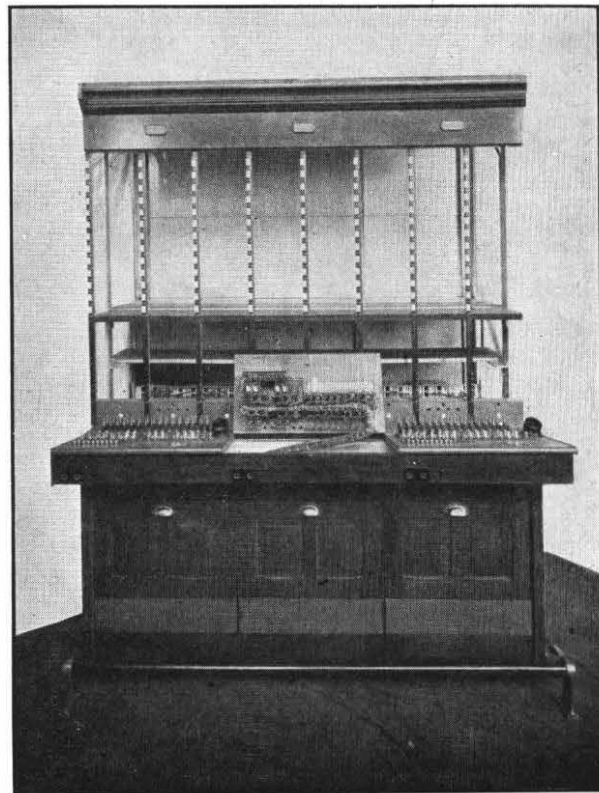

FIG. 4.—A RENOVATED SECTION.

the cords after the fibre has been glued. The finish is the same as that given to the keyshelves.

#### Assembly.

The sections next pass to the assembly shop, where the necessary components are fitted to the framework. These consist of key mountings, keys, relay mountings, relays, resistors, condensers and connection strips. Jacks, plugs and cords are not fitted, although plugs are assembled to cords and supplied separately with the section, together with pulley weights. The whole of the jack field is normally fitted by the Area Staff on site and they are usually responsible for providing the multiple (referred to later). The sections are assembled with either "A" or "B" type cord circuits. There are also other slight differences in equipment fitted due to the fact that some sections have to operate from a 22-volt and others from a 40-volt supply. Fig. 4 shows the front view of a completed section (including wiring).

To give an idea of the magnitude of the task, a list is given in Table I of some of the items which are required in "A" and "B" type sections. In column 4 are given the total quantities of those particular items which have to be provided to complete the total order of sections which the factory has in hand at present; i.e. for 80 "A" position and 20 "B" position sections.

TABLE I.

Item (1)	"A" position (2)	"B" position (3)	Total (4)
Lamp Caps, various ..	135	20	11,200
Clocks 44 .. ..	12	—	960
Retardation Coils ..	44	—	7,520
Condensers, various ..	145	27	12,240
Plugs & Swbd. Cords ..	96	102	9,720
Lamp Jacks .. ..	134	128	13,280
Keys .. ..	144	138	14,280
Key Mountings .. ..	39	54	4,200
Pulleys .. ..	96	102	9,720
Pulley Weights .. ..	96	102	9,720
3,000-type Relays & Covers .. ..	153	18	12,600
Resistors .. ..	253	26	17,400
Labels, various .. ..	68	85	7,440

Owing to the difficulty of purchasing all the relays needed, the Factories Department undertook to produce three-quarters of all the relays and retardation coils needed for the whole job.

#### Wiring.

The interconnection of the various components is carried out by means of a cable form specially made for the job. It is built up in stages on a wooden board 7 ft. long by 6 ft. wide in which are drilled a number of holes. Metal pegs about 2 in. long are fitted into these holes and a pattern is made which conforms to the shape the cable would have if it

were laid out quite flat. Slotted wooden slats may be used instead of metal pegs, as will be seen from an examination of Fig. 5, which shows a cable partially

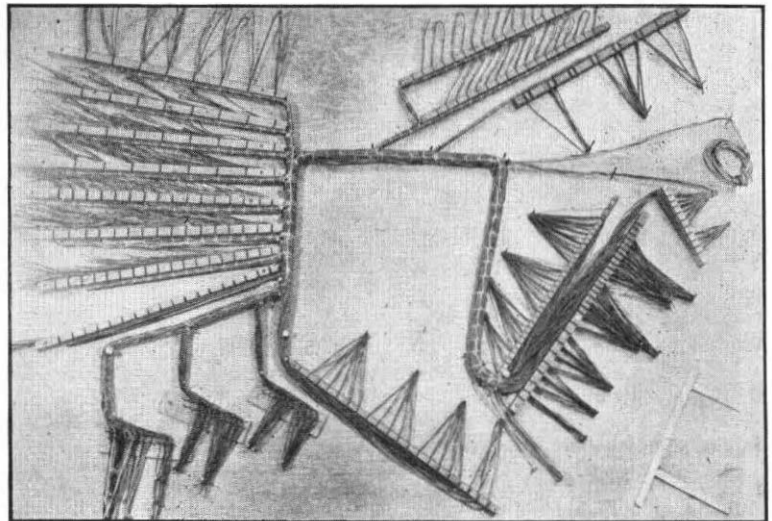

FIG. 5.—CABLE FORM PARTIALLY LACED.

laced. The shape is such that the finished cable can be fitted to the assembled switch section and the various runs correspond with the framework, key-shelf, cord-shelf and the relay, condenser and connection strip assembly.

In forming the cable it is the practice to start and finish each separate colour of wire completely, commencing with the generator feed to all the keys, then the calling cord lamp circuit, next the speech circuits, and so on until the cable is complete. The cable is then laced and removed from the forming board and after drying, is impregnated by immersion in a bath of molten wax. The cable is removed from the wax bath, allowed to drain and cool, and is then ready for fitting to the assembled switch section.

Those employed on wiring sections have had many years experience. It will be appreciated that it is essential to avoid having to find mistakes on a job in which each section uses 3,000 yards of wire and contains 4,000 soldered joints. (These figures refer only to the work done by the Factories Department, and exclude the wire and soldering done on site when the multiples and jack fields are added.)

After the wiring has been finished, the section is tested by the Engineering Department's Test Section who check in detail the operation of each circuit and every function of the section, working to the relevant performance specification. After it has been approved, the section is held by the Stores Department until required.

#### Manufacture of Cable Multiple.

Many multiples have been made for supply to the Regions and it may be of interest to describe the method.

The cable used is 60 wire/9½ flat switchboard cable, and it is first cut into lengths depending on the desired spacing of the multiple, for example 6 panel or 8 panel. The outer covering of the ends of the cable is stripped



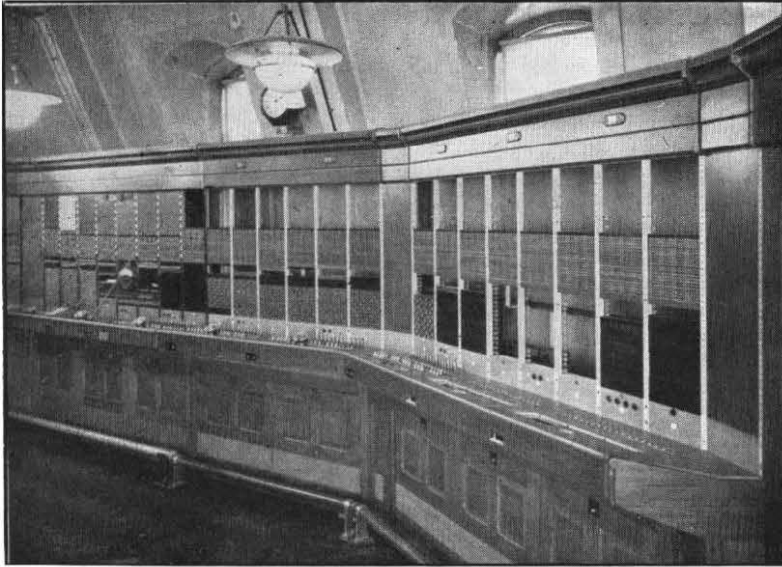

FIG. 6.—RENOVATED SECTIONS IN BRENTWOOD EXCHANGE.

off as required for the length of skimmers and the exposed ends immersed in beeswax after being thoroughly dried. This is necessary to seal the end of the outer covering and prevent the covering of the individual wires from fraying.

The wire ends are then tied out in a former, after being arranged according to the colour scheme required. The left-hand end of the piece of cable is called the "A" end, and the right-hand end the "B." The "A" end of one piece and the "B" end of the next piece are then placed together in another former which also carries the jack, and the wires are connected to the jack. This process is repeated until the required number of jacks has been connected, when the cable butts are placed in a press to bring the size of the form to the standard size of the finished multiple. The form is then brushed to remove superfluous wax and the butts of the two forms tied together. The complete multiple is then tested for continuity and insulation.

If so required, the "growing" end of the multiple is formed but not connected to jacks; the form is sleeved and taped and will be coiled up in the cable storing section on site.

#### *Installation.*

As a matter of interest, it may be stated that the installation of Switch Sections, C.B. No. 1 has been undertaken as well as their complete renovation. Edinburgh Central relief exchange consists of a number of sections which were recovered from Kingston-on-Thames exchange by the Factories Department, transported to Edinburgh and renovated on site as no major renovations were required. The recovery and installation were carried out in co-operation with the respective local staffs. Edinburgh, Leven, is a new relief exchange which will shortly be equipped entirely by staff of the Birmingham factory, using renovated sections which were also recovered from Kingston-on-Thames.

#### *Conclusion.*

Besides the standard sections described above, sections have recently been renovated for exchanges at Maidenhead (including supply of the multiple), Scarborough, Westbourne, Warrington, Brentwood, Birkenhead and Northampton in accordance with exchange specifications, i.e. "tailored" to individual requirements. Requisitions are now being met for standard sections of the type just described for installation at Fleetwood, Worthing, Huddersfield, Morecambe and Carlisle.

Fig. 6 shows part of the switchboard in Brentwood exchange which has been extended by the addition of one 2-position section and one 3-position section, seen in the centre and to the right-hand side of the illustration respectively. Fig. 7 shows a view of the rear of the new sections and illustrates how it has been possible to utilise sections which are more shallow than those forming the existing suite. One cover has been omitted from the new sections to show the relay assembly (pre-3,000 type in this case).

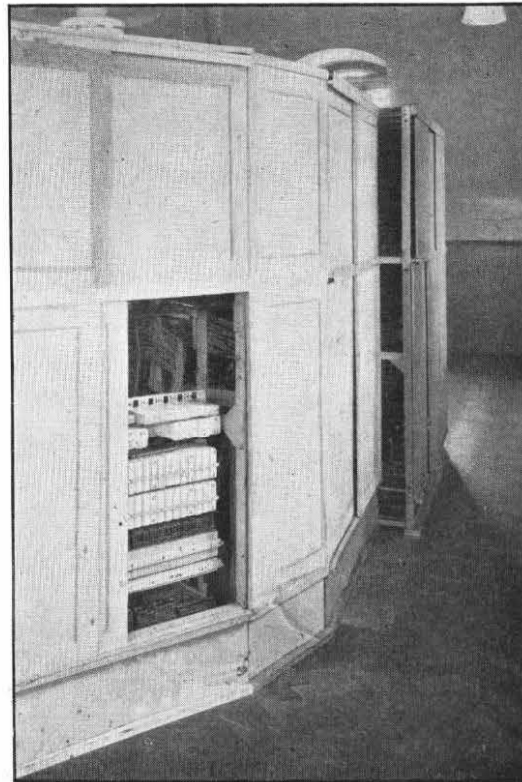

FIG. 7.—REAR OF SECTIONS SHOWN IN FIG. 6.

#### *Acknowledgments.*

The authors desire to thank members of the staff at Birmingham Factory for much help in preparing this article, and in particular, Mr. A. F. Bliss.

## H.M.T.S. "Alert"; ex-German Cablesheet "Norderney"

The grievous loss of H.M.T.S. *Alert*, as a result of enemy action in February, 1945, was the worst blow suffered by the Submarine Branch of the Post Office during the late war, and although the loss of this gallant ship's company can never be made good, the story of *Alert's* successor will be of interest.

In June 1945 the German cablesheet *Norderney* was brought over from Germany by her German crew to Methil on the Firth of Forth, together with other seagoing German ships which were being taken over as prizes. Upon arrival there the German crew were sent to an accommodation ship, for transfer back to Germany, and *Norderney* was taken over by the captain and crew of the Post Office cablesheet *Monarch*, which had also been lost by enemy action in the North Sea on 16th April, 1945.

boilered by the Germans and in 1941 the officers' accommodation was rebuilt as a result of damage suffered during an air raid. The boat-carrying arrangements did not comply with British requirements, and to provide for this the boat deck forward of the navigating bridge has been extended. There is a good clear deck space for the working of submarine cable below this boat deck. The foremast has been considerably shortened and the German mainmast has been removed and has been replaced by a light signal mast at the after end of the bridge house.

The navigational equipment of the vessel is very complete and includes an Anchutz gyroscopic master compass and repeaters in addition to British magnetic compasses. An echo-sounding apparatus of the latest British design has been fitted, and a German sub-

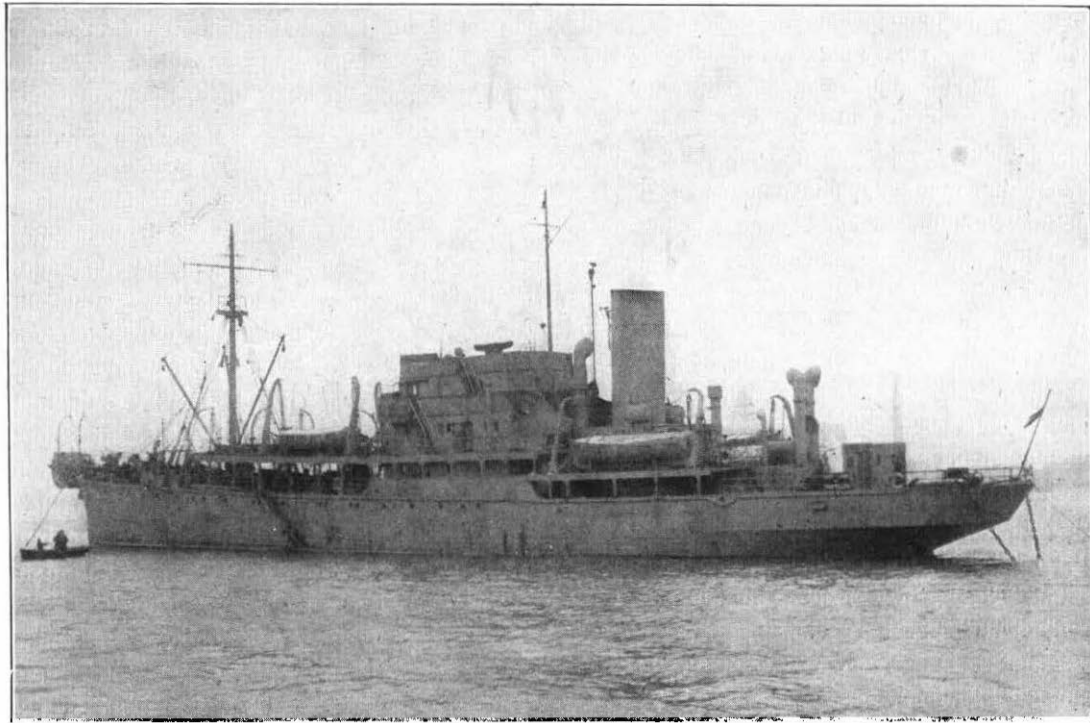

FIG. 1. H.M.T.S. "ALERT."

*Norderney* then proceeded from Methil to the Post Office cable depot at Woolwich, where all the prize cable which was on board was landed, and on completion of this work she was taken to Southampton and put into the hands of Messrs. J. & I. Thornycroft for a major refit and overhaul. This involved a considerable amount of structural alteration to the vessel in order that she should be brought up to the standard required by the Post Office, and Fig. 1 shows the ship on completion of this work.

She has been re-named *Alert*, and is a twin screw steamship of 1,487 tons gross. Her length is 255 ft. and beam is 35 ft. In 1938 she was re-engined and

marine signalling gear, working in conjunction with a wireless direction finder, is also part of the equipment carried. A British Admiralty pattern radar set has been added, and wireless telegraphy and telephony are, of course, available.

*Alert* is capable of carrying about 600 tons of submarine cable in her three cable holds. She has now taken up her duties, together with H.M. Telegraph Ships *Ariel* and *Iris*, in the maintenance of the network of submarine telephone and telegraph cables around the coasts of the British Isles. Her base is the G.P.O. cable depot at Woolwich.

W. H. L.

# Shared Service

U.D.C. 621.395.331.3

C. J. CAMERON, A.M.I.E.E.  
and W. A. HUMPHRIES, A.M.I.E.E.

To assist in reducing the present long waiting list for telephone service attention has been directed to schemes in which two subscribers share a single exchange line and equipment. The authors outline earlier forms of shared service and detail the facilities which are now considered necessary to give an acceptable service. The circuit arrangements for manual and automatic systems are covered and particulars given of shared service applied to extension plan installations.

## Introduction.

**S**HORTAGES of telecommunications plant and equipment, a legacy of the war years, and deferment of any full-scale replacement programme, has made it more than ever necessary for a service whereby, fundamentally, two subscribers share a single exchange line and equipment, to be viewed as a major project rather than a temporary expedient for giving telephone service as was originally intended. The present situation may be ascribed to national economic difficulties which have given rise to curtailment of capital expenditure and diversion to export of more than 50 per cent. of the country's telecommunications manufacturing capacity, apart from general labour difficulties. Telephone service on a sharing basis, whilst only a very small fraction of the total service, was expanded during the war years, primarily as a means of giving service to specially graded applicants for whom no spare wires were available, or where the provision of exclusive line service would have involved work in excess of prescribed limits. Present policy dictated by existing circumstances is now such that this form of service is to be used to the maximum practical extent. The following review of the various forms of giving service on a sharing basis and their application to present-day needs, may, apart from general interest, appropriately serve to indicate developments completed or in hand to provide an acceptable service, which for satisfactory operation requires a minimum of special apparatus and equipment. Throughout the developments, it has been appreciated that a service applicable to all existing types of exchanges is required, which as far as possible should remove any prejudice to shared service, imaginary or otherwise; it should be acceptable to both existing exclusive line subscribers and new applicants for service.

## Early Forms of "Shared" or Party-Line Service.

Briefly, the various forms whereby one exchange line can be made to serve two or more subscribers are as follows:—

*Rural Party-line Service (Manual).*—A service originated long before 1920, mainly for farmers, in which as many as twelve subscribers have been catered for by teeing to a single exchange line. Subscribers were divided into two groups for ringing purposes; a call for any subscriber in either group resulted in the bells of all subscribers of the group being rung, the wanted party being distinguished by a system of code ringing. The service was non-secret, and all calls were ticketed, a special tariff being fixed under which the party-line subscribers were allowed free calls to all other subscribers connected to the exchange serving the party-line. American practice

is somewhat similar and from published references appears to be a recognised and welcomed form of providing scattered rural communities with a means of "free-for-all" gossip. Somewhat more elaborate arrangements are, however, available to the American public as regards selective ringing, but for lack of the facility mentioned above would seem to find little favour in scattered farmstead areas.

*Group Service (Manual and Automatic Exchanges other than U.A.X.s)*<sup>1</sup>.—This service was introduced in 1934 to serve up to eight subscribers by means of a single exchange pair and two control wires. Certain restrictions were imposed as regards the relative geographical position of the subscriber and the exchange, but apart from this, service was given at a rental less than that for a direct exchange line. Each subscriber was rung independently of the other parties of the group, separate metering in automatic areas and secrecy being features of the scheme. Special equipment was necessary at the exchange and at the subscriber's end where a control point relay set serving the eight subscribers was fixed to a convenient pole or pillar. The service, although an improvement on the old rural party-line arrangement, had disadvantages in that it was only suitable for subscribers with low calling rates, and in the event of the line being in use by any party of the group precluded use of the telephone, in an emergency, by the sharing partners. Intercommunication between subscribers of the group was possible with the aid of the exchange operator but without secrecy. The small difference in rental as compared with exclusive line service was such as to attract few subscribers and the service has fallen into disuse and is not now provided.

*Country Satellite Exchanges (Manual and Automatic)*<sup>2</sup>.—This service was introduced in 1935, to serve up to ten subscribers in a rural district remote from an existing exchange, where the cost of providing direct exchange lines to each subscriber was prohibitive. Prior to the advent of the country satellite scheme, service in such cases was given by a small manual exchange, or by a small unattended automatic exchange, or alternatively by party-line, all of which gave grounds for objection, either on the score of the need for operator attendance, or special buildings and power plant, or on the grounds of lack of secrecy. Special discriminatory equipment was necessary at the parent exchange and at the subscriber's end, that required at the latter being housed in weatherproof containers fixed to a convenient pole or pillar. Whilst arrangements were such that intercommunication was possible between subscribers of the group, a high

<sup>1</sup>P.O.E.E.J., Vol. 26, p. 278.

<sup>2</sup>P.O.E.E.J., Vol. 26, p. 125.

calling rate was a disadvantage. Nevertheless, this and the inability to use the telephone in the event of an emergency should the line be in use, assumed insignificant importance in giving service to a group of subscribers centred around a village or hamlet and a number of these installations are in service. Increase of their number is, however, limited as there are few equipments now available.

*Party-line Service by means of Extension Plans.*—Simple party-line service can be given by means of internal or external extensions depending on the precise situation of the sharing parties. Such a service, however, makes it necessary for all incoming calls to be received by one party and for that party to monitor all calls. Alternatively, the bells of both installations can be rung simultaneously, signalling intercommunication being arranged between the two parties. Apart from the obvious disadvantages of such a system, the service necessitates the acceptance of joint accounts. Generally this service is one offering engineering advantages only where there is a shortage of spare exchange multiple.

*Two-Party Line Service (Automatic and Manual).*—Under this heading two distinct forms of service are concerned, i.e. that of service to (a) manual, and (b) automatic subscribers. Manual service is merely a form of rural party-line restricted to giving service to two subscribers only. The automatic service was introduced to continue party-line service when an exchange was converted from manual to automatic working. It required special equipment at the exchange to give meter discrimination, the appropriate meter selection being made by loop calling for one subscriber and by earth, applied either as a fleeting contact or during dialling, for the other subscriber. Ringing discrimination was achieved by ringing over the A line and earth in the one case and over the B line and earth in the other. The service was non-secret; separate accounts were, however, rendered. With revision of telephone rentals in 1934 the service fell into disuse and few, if any, installations now exist.

*Joint User (Automatic).*—This service was introduced in 1942 as a temporary expedient and differed from that of automatic two-party line service in that special equipment was not provided. A single calling equipment at the exchange was used, but two multiple appearances were provided for selective ringing. All calls with the exception of those via the manual board were recorded on a single meter, a joint account being rendered in respect of these calls. The rental for this service was the same as that for exclusive line service.

#### *Post-War Considerations.*

Difficulties in the provision of telephone service since the end of the war have necessitated from time to time review of the foregoing forms of giving service on a sharing basis. As a result of deliberations, agreement was reached that special equipment for separate metering on the scale required for the old two-party scheme in automatic areas could not be justified. There was however, support for the view that the joint-user service introduced as a temporary expedient was giving reasonable service and that there was a

definite potential market for shared service as a whole. Accordingly, it has been decided that shared service is to be developed on the following lines :—

1. A flat rate tariff cannot be adopted to avoid the necessity for separate metering at automatic exchanges.
2. A separate metering scheme using two subscribers' calling equipments and little, if any, special equipment is to be introduced forthwith at standard uniselector and 2000-type line finder exchanges and at U.A.X.s No. 14; also, subject to satisfactory development, at U.A.X.s Nos. 5, 6, 12 and 13. At other, non-standard, automatic exchanges the need for shared service is, for the time being, to be avoided by providing additional line plant.
3. A separate metering system using a single subscriber's calling equipment is to be developed as a matter of urgency and is to embrace Siemens No. 16 exchanges.
4. Action is to be taken to remove the possibility of false rings and bell-tinkling.
5. All potential sharing subscribers are to be provided with handsets without extra charge, and as soon as supplies permit, all such installations are to be wired in readiness for shared service.
6. The range of Extension Plan installations available to sharing subscribers is to be increased.
7. Service is to be given on a sharing basis by means of Extension Plan working in certain cases.
8. Local line plant schemes are, for the time being, to be planned on current development forecasts as heretofore.

The standard forms of shared service which are or which will ultimately be available to the public, carry for the time being the following titles :—

- |                                        |                        |
|----------------------------------------|------------------------|
| (a) Shared Service (Manual)            | } (Automatic Systems.) |
| (b) Shared Service (Common Metering)   |                        |
| (c) Shared Service (Separate Metering) |                        |

Services (a) and (b) are in fairly common use while (c) is undergoing field trial in a number of specially selected director and non-director areas, and its use is now being extended.

#### *General Principles of Shared Service Working.*

Two subscribers share a single exchange line and where possible a single calling equipment. A separate exchange number, necessitating the use of two multiple appearances, is allocated to each of the two sharing subscribers except where service is given by Extension Plan working. Selective ringing is a standard feature of the scheme and is achieved by ringing over the A line for one subscriber and over the B line for the co-partner. Sharing subscribers' installations carry the designations X and Y. The X installation is that at which ringing is effected by applying ringing conditions at the exchange as for a direct exchange line, and for the common metering scheme is that against which outgoing dialled calls from either installation are metered on a "joint account" basis. The Y installation is that which is rung by reversing the ringing conditions applied at the exchange. Standard apparatus and equipment with minor

changes and additions are used on the manual and common metering systems. Telephones with special

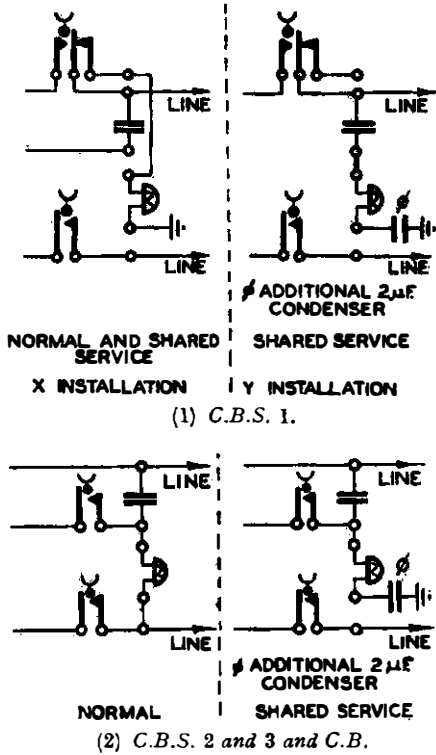
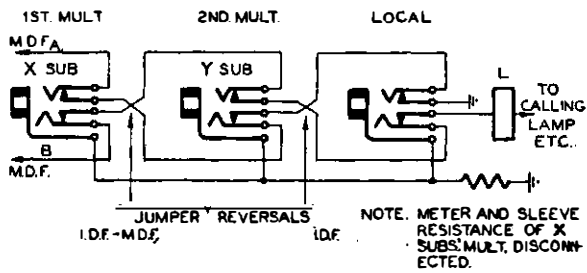

FIG. 1.—MANUAL WORKING—ALTERATIONS AT SUBSCRIBER'S PREMISES.

push-button calling facilities are required in the separate metering system. From the functional point of view there is little change from normal instrument and exchange working; such differences as there are are specifically referred to later. Listening-in is possible with all the three standard types of shared service should one of two sharing subscribers pick up the telephone to originate a call whilst the other is using the line; on average this it is estimated is unlikely to occur more than ten times in a year. Inter-communication between the two sharing subscribers is possible with the assistance of the operator. The foregoing principles apply to the three specific forms of shared service, descriptions of which follow.

*Shared Service (Manual).*

This service is applicable to manual exchanges of all types; it is, however, necessary when providing shared service in magneto areas to convert the subscriber and exchange terminations, and a proportion of the cord circuits, to C.B.S. No. 1 working. This is necessary to avoid false rings which would otherwise arise when signalling from the subscriber's installation to the exchange. In these circumstances the D.C. loop call, A wire earth clear method of working replaces the A.C. generator signalling of the magneto system. At the subscribers' premises standard instruments of the one-piece or two-piece type are used throughout; it is, however, necessary to add a  $2\mu\text{F}$  condenser and to make a small wiring change at each installation with the exception of that of the C.B.S. No. 1 X station. The changes necessary are shown in principle in Fig. 1. The additional  $2\mu\text{F}$



(1) C.B.S. 1 Multiple Exchanges.

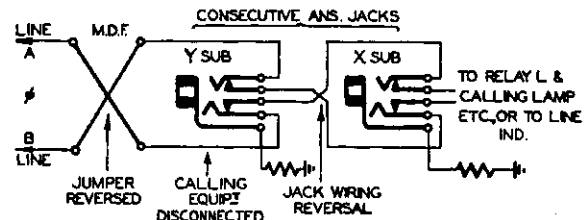

(2) C.B.S. 1 and 2 Non-multiple Exchanges.

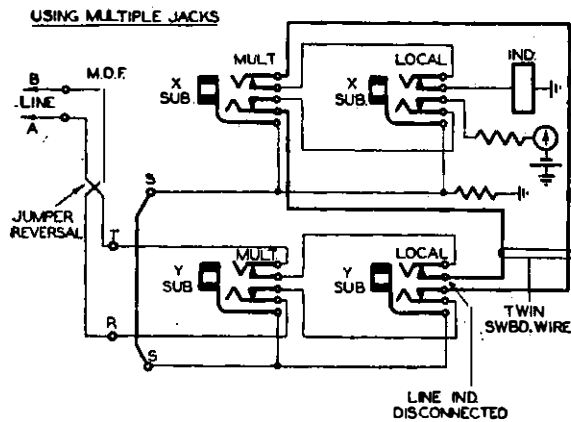

(3) C.B.S. 2 with Restricted Multiple.

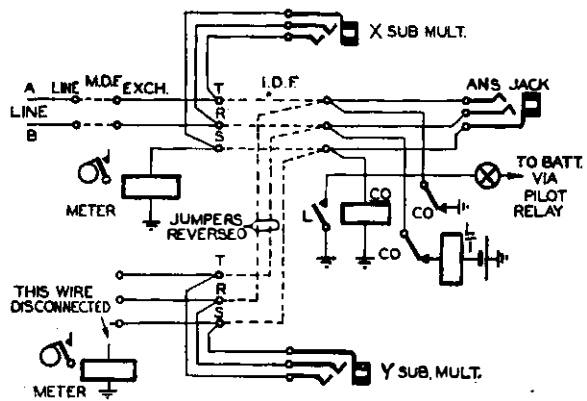

(4) C.B. Exchanges.

(5) C.B.S. 2 Exchanges without Multiple Jacks. At 3-position exchanges two consecutive jacks on the central position are used if convenient, the arrangements being as for (2).

FIG. 2.—MANUAL WORKING—ALTERATIONS AT EXCHANGE.

condenser is provided to prevent earth being connected directly to line during speaking conditions, thus minimising the possible disturbance effects of line unbalance and earth currents. At the exchange, selective ringing necessitates wiring changes but no additional equipment. The necessary changes are shown in Fig. 2.

With the expansion of shared service working, the alterations to the permanent wiring and loss of calling equipments at C.B.S. non-multiple and restricted

multiple exchanges with the arrangements depicted in Fig. 2 (2) and (3) are not tolerable, and in future the two sharing subscribers will be terminated on one jack and calling equipment. A ringing reverse key will be fitted on the switchboard and used when calling the Y subscriber. The Y subscriber will be given the same exchange number as the X subscriber, but with a special prefixed digit to place it outside the normal exchange numbering range. For magneto exchanges the complications of associating a ring reverse key

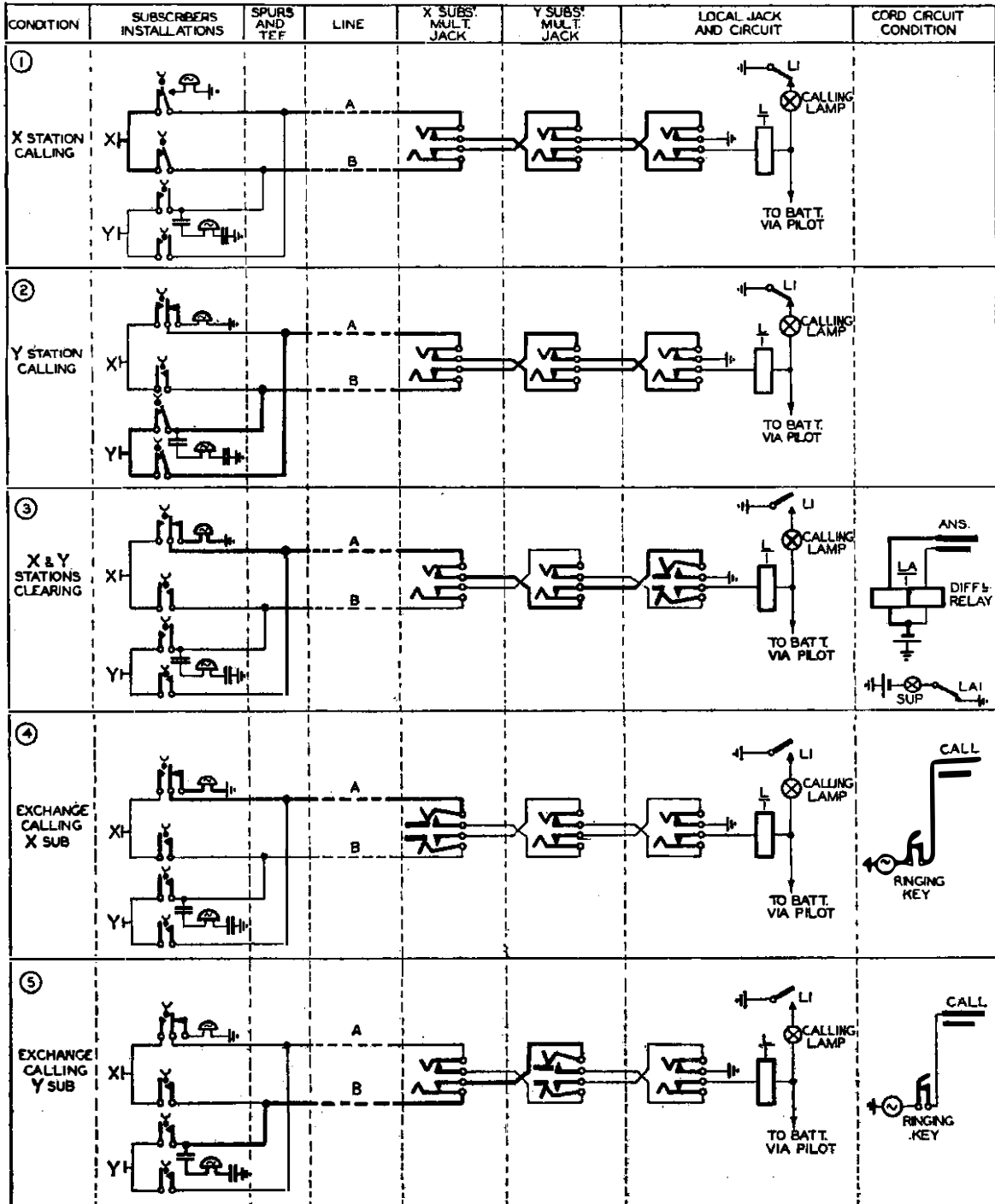

FIG. 3.—CALLING AND CLEARING CONDITIONS FOR C.B.S. 1 INSTALLATION.

with special cord circuits and the small number of exchanges involved does not justify a change in the method of providing shared service. The foregoing sets out the whole of the changes necessary to afford shared service facilities in manual areas. The actual calling conditions to and from the exchange and the clearing conditions to the exchange for a typical C.B.S. 1 installation are shown in Fig. 3, which should be considered in conjunction with the explanations so far given.

In C.B.S. No. 1 areas (including magneto areas) where one sharing subscriber is more than 2 miles farther from the exchange than the other, the more remote station must be made the X station to avoid the possibility of false clears. Two points only remain to be covered and are referred to hereunder.

*Ring Trip.*—Answering by the called party while the operator has her ringing key operated results in extending the ringing current over that subscriber's loop to the bell of the sharing partner, the latter being called to the telephone unnecessarily. This trouble can be minimised by operators giving rings of short duration on shared service installations, but a much better solution is to be found in fitting, whenever possible, ring trip relays in the position ringing leads. This can be done without much difficulty at C.B. exchanges and will shortly be introduced as the standard arrangement. It is not practicable, however, where machine ringing and secondary cells are not available. The design of a suitable ring trip relay for use with C.B.S. working presents some difficulty even when a ringing machine and secondary cells are available and further investigation of the C.B.S. case is in hand.

*Bell-tinkling.*—Tinkling of the bell is caused by current surges due to the inductive effects of the line relays during flashing (and also during dialling in automatic areas, which are considered later but which from the tinkling aspect can be conveniently considered here). Hitherto, bias springs have been used to suppress tinkling; their use has, however, been restricted to shared service on automatic working. The adjustment of bias springs is critical and such that suppression of tinkling is achieved only at the expense of some degradation in the ringing efficiency of the bell. Under the conditions of varying line characteristics that have to be catered for, it is not surprising that their use has not given complete satisfaction. Thermistors, small glass-enclosed resistors having a negative temperature coefficient, offer a possible cure for tinkling, but their adoption ultimately will depend on experience of their behaviour in use, details of which at the moment are lacking. At present, a cure is to be found in the use of a bridge-rectifier relay unit, a contact of the relay being used to isolate the installation bell except under ringing conditions. As a matter of policy this bridge-rectifier relay unit will replace the bias spring as soon as it is available in quantity and will ultimately be fitted as standard at all shared service installations with the exception of C.B.S. No. 1 X installations where it is essential to retain the A line earth connection. The case of the C.B.S. No. 1 X installation is under review. Typical arrangements

for installations using instruments of the one- and two-piece types are shown in Fig. 4.

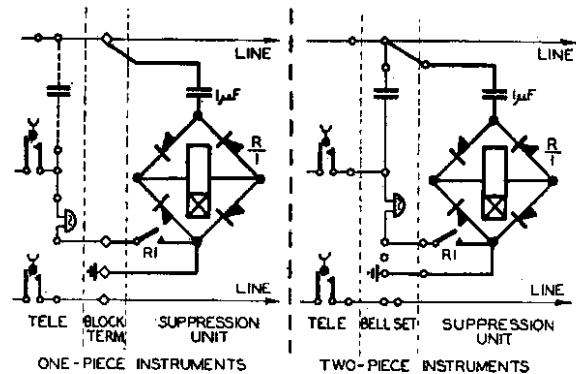

FIG. 4.—TYPICAL ARRANGEMENTS FOR SUPPRESSION OF BELL-TINKLING.

Ringing current applied to the appropriate line at the exchange initially finds a path via the  $1 \mu\text{F}$  condenser, full-wave bridge rectifier, and slow-to-operate relay, to earth. The relay operates to ringing current after a short interval of time and at R1 connects the bell and condenser of the telephone instrument in parallel with the bridge rectifier, etc., to earth and the installation bell is rung. The slow-operate feature of the bridge rectifier relay guards against false operation and unwanted bell response likely to arise from short duration current surges but is designed to respond to interrupted ringing currents.

#### Shared Service (Common Metering).

This service is applicable to all types of automatic exchanges except U.A.X.s Nos. 9, 10 and 11 and any non-standard exchanges at which circuit changes would be necessary. As distinct from the manual and separate metering schemes, all calls with the exception of those via the manual board, are recorded on a *single meter*, joint accounts being rendered in respect of these calls. Two subscribers share a single line and single calling equipment but have individual multiple appearances. At the subscribers' premises standard instruments of the one- and two-piece types are used throughout; it is, however, necessary to add a  $2 \mu\text{F}$  condenser and make a small wiring change at each installation. The changes necessary are as for those of the shared service manual scheme referred to under that heading, and shown in principle in Fig. 1 (2). At the exchange, selective ringing necessitates reversed jumpering between the Y subscriber's final selector multiple and the line. Apart from the additional condenser no extra apparatus or equipment is required. A typical installation and exchange termination is shown in Fig. 5.

As will be seen, either subscriber calls the exchange by looping the A and B lines in normal manner, the calling equipment functioning as for standard automatic working. Seizure of the calling equipment connects earth to the P wire and busies both final selector multiples. The jumpers of the Y subscriber are reversed at the M.D.F. and this, in conjunction with the reversal of the A and B lines of the Y sub-

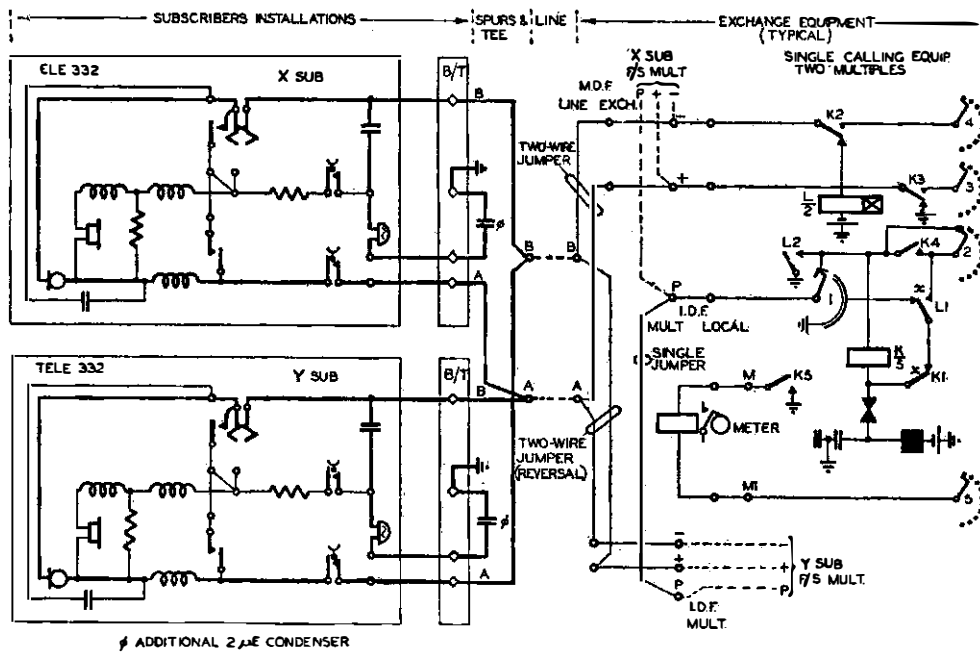

FIG. 5.—TYPICAL ARRANGEMENTS FOR SHARED SERVICE WITH COMMON METERING.

scriber at the tee point, caters for selective ringing. A cure for bell-tinkling is to be found in the ultimate standard use of the bridge-rectifier relay unit referred to earlier, this unit replacing bias springs and the additional condenser at both subscribers' installations shown in Fig. 5, the arrangements being as shown in Fig. 4. This scheme has the advantage in that use is made of a single calling equipment, thereby effecting economies in plant utilisation; it suffers, however, from the subscriber's point of view in that it entails the acceptance of joint accounts for all calls other than those obtained via the manual board.

*Shared Service (Separate Metering).*

In the form that this service was available before 1939 a fairly large auxiliary relay set was required at the exchange. Because of the shortage of exchange equipment it would not therefore have been possible to achieve the required large-scale extension of shared service by using the pre-war design of equipment, and simpler methods of obtaining separate metering were sought.

The first scheme devised did not require any auxiliary relays at the exchange, separate metering being achieved by giving each subscriber a separate calling equipment and providing a calling button on each subscriber's telephone. Depression of the calling button at the X subscriber's installation connected earth to the B wire of the line and depression of that at the Y installation connected earth to the A wire of the line. At the exchange the X calling equipment had its L relay connected to the B wire and the Y calling equipment had its L relay connected to the

A wire. Thus, depression of the calling button by the subscriber ensured that the call was connected via the correct calling equipment and that the appropriate subscriber's meter was taken into use. The scheme was devised for use at standard uniselectors exchanges, 2000-type linefinder exchanges and U.A.X.s No. 14, and is shown in principle in Fig. 6.

It will be observed in Fig. 6 that earth must be disconnected from the positive wire of each subscriber's

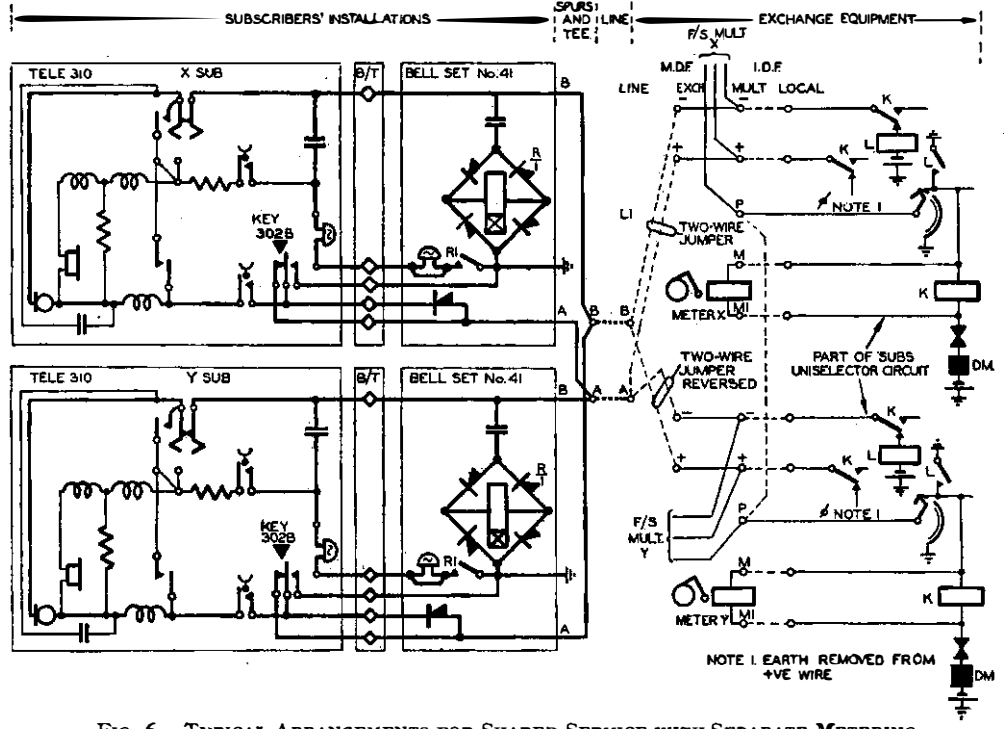

FIG. 6.—TYPICAL ARRANGEMENTS FOR SHARED SERVICE WITH SEPARATE METERING.



calling equipment to prevent the L relays operating via the reversed jumper connections inserted in the Y subscriber's circuit at the M.D.F. to provide selective ringing. At the subscriber's premises a telephone of the one-piece type (Tele. No. 310), which includes a push-button and a special bell-set (Bell-set No. 41) were fitted. The special bell-set included a rectifier used in conjunction with the push-button change-over spring-set of the telephone instrument for calling purposes, and also apparatus for bell-tinkling suppression. It will be seen from Fig. 6 that depression of the calling button with the handset off its cradle connects earth via the telephone instrument to the B wire for the X subscriber and to the A wire for the Y subscriber. The rectifier associated with the calling button prevents the calling earth from being extended to the A wire (X subscribers) and B wire (Y subscribers). The rectifier is necessary to maintain a holding loop to the 1st selector A relay at the exchange irrespective of the position of the calling button and so prevent a false impulse to the selector during the release of the button after dial tone is received.

The arrangement shown in Fig. 6 has the drawback that a plain loop across the A and B wires does not operate either of the calling equipments. Loops can occur in this way due to line faults or a subscriber failing to replace his handset when the caller has cleared after an incoming call, or if a subscriber lifts his handset without pressing his calling button. Should the other subscriber depress his calling button while such a loop is across the line, the earth from the calling button is connected to both the A and B wires; in these circumstances both subscribers' L relays operate and the line is connected to two 1st selectors. The A relays of the two selectors then lock in the operated position via the jumper reversal on the M.D.F. and remain held until the "lock-up" is cleared by hand at the exchange. It was considered that the frequency of occurrence of this lock-up would be too great to permit the satisfactory introduction of service by this method and a circuit consisting of the addition of two relays per shared service line was designed to prevent "lock-ups". These relays are connected in the circuit at the I.D.F. between the line and the two subscribers' calling equipments.

Because of the time required to provide relays, the scheme illustrated in Fig. 6 was re-examined, and it was decided that lock-ups occurring due to nearly simultaneous origination of calls by the two subscribers could be reduced to negligible proportions by instructing the subscribers to depress their calling button before lifting the handset from the cradle, and field trials of the scheme with this method of operation by the subscriber are in progress. The information obtained to date from these trials is insufficient to determine exactly the conditions under which the relays to prevent lock-ups are essential, but have indicated that a reasonable service can be given without relays, at least at exchanges where regular maintenance attendance is available for some part

of the day. Authority has therefore been given for the provision of the shared service (separate metering) scheme without anti-lock-up relays at standard unselector and 2000-linefinder exchanges and U.A.X.s No. 14 at the discretion of Telephone Managers, wherever the availability of subscribers' calling equipments permits it to be used. A decision as to the conditions under which anti-lock-up relays should be used has been deferred until more experience has been obtained as to the service given without the use of these relays. The shared service (separate metering) scheme using two calling equipments but without auxiliary relays at the exchange cannot be used at pre-2000 type linefinder exchanges because the normal busy condition to the final selector during an outgoing call is a disconnection of the P-wire and so cannot be used to busy the final selector multiple of the other subscriber. A scheme has been devised using two relays per shared service line as shown in Fig. 7. The subscriber's apparatus is the same as for the separate metering scheme already described.

It will be seen from Fig. 7 that the subscriber's calling earth is extended to the L relay in the appropriate calling equipment and that relay KX or KY is

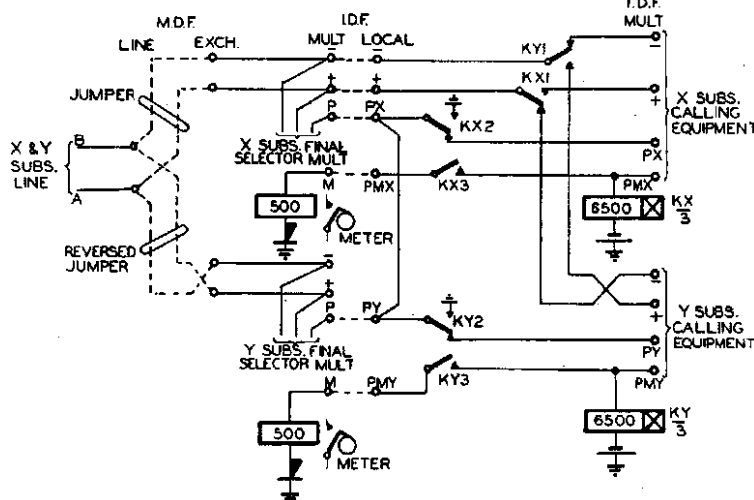

FIG. 7.—CIRCUIT FOR SEPARATE METERING SYSTEM ON PRE-2000 TYPE LINEFINDER EXCHANGES.

operated to busy both final selector multiples and disconnect the unwanted calling equipment when a linefinder switches to the calling subscriber. Busying of the final selector multiples is thus deferred until a linefinder switches to a calling line but this is not expected to cause any serious difficulty as shared service subscribers will have comparatively low calling rates. This scheme has two restrictions:—

- (a) It cannot be used with pre-2000-type linefinders having pre-3000-type relays because relays PA and PB in the linefinder are so sensitive as to switch to the battery via KX or KY when they should hunt over a shared service line.
- (b) Shared service subscribers must not be connected to both odd and even outlets of the same position on a linefinder bank as the linefinder can then switch falsely to battery via two KX or KY relays in parallel.

This method of providing shared service (separate metering) at pre-2000-type linefinder exchanges is to be introduced when the relays are available.

Methods of providing separate metering by using two subscribers' calling equipments but without any auxiliary relays at U.A.X.s Nos. 5, 6, 12 and 13 have recently been proposed and arrangements are being made for field trials of these schemes.

A method of preventing lock-ups at 2000-type linefinder exchanges without using relays has also been suggested and a field trial of the proposal is in progress.

It is appreciated that all the methods of providing separate metering which have been described so far are restricted in their application to exchanges which have sufficient spare calling equipments to permit one being allotted to each subscriber. The development of simple relay sets which can be used to provide separate metering when associated with a single standard subscriber's calling equipment is therefore in hand and for uniselectors and 2000-type linefinder exchanges and U.A.X.s No. 14 development has reached an advanced stage. For Siemens No. 16 exchanges the relay set required to provide separate metering using two calling equipments would be as big as that for use with a single calling equipment and development has therefore been confined to the single calling equipment case. For all schemes envisaged for separate metering, push-button calling, using Teles. No. 310, and Bell-set No. 41 has been adopted as standard. The development of separate metering schemes for manual exchanges has been considered but the additional equipment or changes to existing equipment required to provide a satisfactory scheme are not justified, in view of the small saving in operating time that would accrue from the avoidance of ticketing.

#### Shared Service (By means of Extension Plan Working).

In addition to the three forms of service described, a simple Extension Plan has been devised for use in cases where there is a shortage of spare exchange multiple. Two subscribers are connected in parallel to a single line, use being made of a single exchange number common to both subscribers. Incoming rings are received simultaneously at both subscribers' installations, simple signalling intercommunication being provided between the two stations. The arrangement can be provided using standard instruments of the one- or two-piece types, a typical installation of the latter type being shown in Fig. 8.

#### Supplementary Facilities on Shared Service Lines.

Extension Plans 1, 1A, 1B, 4, 5, 5A, 7 and 7A are now available as standard installations with the exception that the last four are not permitted (a) on local battery systems or (b) on C.B. and automatic systems using Bell-set No. 20; in the latter case service is given using Bell-set No. 39. Increase in the number of Extension Plans for shared service working has been undertaken with the object of increasing the scope of shared service both as regards existing exclusive line subscribers willing to share their line, and new applicants for telephone service. In ex-

tending the number of standard arrangements, changes to the permanent wiring of telephone instruments and subsidiary apparatus have been avoided and have been restricted to Extension Plans for which there is a popular demand. Requirements for installations other than those referred to are dealt with on a non-standard basis. The subscriber's operating procedure referred to under the separate

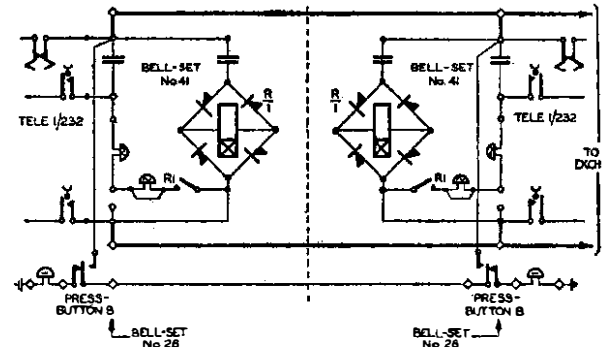

FIG. 8.—SIMPLE PARALLEL EXTENSION FOR USE WHERE EXCHANGE MULTIPLE IS EXHAUSTED.

metering scheme has made it desirable where possible for the calling button to be an integral part of the telephone instrument. At the moment, with Extension Plans 5, 5A, 7 and 7A it is necessary for a separate press button B to be provided as part of the installation at the main station. Whilst there is little prospect of effecting any change as regards Extension Plans 5 and 5A, the case of 7 and 7A is somewhat different in that it is a much more popular service and moreover the left-hand extension call button of Bell-set No. 39 is not required on these installations. In these circumstances development is in hand to replace the simple make-contact spring set of Bell-set No. 39 by a change-over set and minor cable form to permit the left-hand button on the bell-set to be used for calling the exchange on Extension Plans 7 and 7A.

#### Listening-in on Shared Service Lines.

Several schemes for providing secrecy on shared service have been considered. In all cases additional apparatus is required and in nearly all, additional wiring between the subscribers' premises is involved, factors which cannot be readily overlooked in the light of the present restricted programme. Moreover, it has been questioned if secrecy is really desirable with shared service, particularly with residential installations. A secret service has objections on the score that it would deprive one party of telephone service, even for emergency calls, while the sharing partner was using the line and would also prohibit calls between the sharing partners. By special arrangements and additional equipment the foregoing objections can in part be overcome but not with entire satisfaction. The general conclusions reached in considering this question were that the proposals to overcome bell-tinkling would in a large measure reduce complaints of lack of secrecy in that sharing partners would have no indication of the use of the line by the other and any listening-in would arise

from pure chance. For the reasons mentioned it has been decided that the development of a secret shared service is unnecessary for the present.

#### *Conclusion.*

Developments other than those already described are in hand, typical among which are those of a wall-set equivalent of Telephone No. 310, that of a simplified version of Bell-set No. 41, and the association of the components required for bell-tinkling suppression as an integral part of the telephone

instrument. Consideration of many problems, some still unsolved, has fallen to the lot of the various Headquarters Engineering Branches, and to mention only a few are those of local line plant, three-wire wiring, faultsmen's telephones and ring-back facilities, burglar alarm and deaf-aid telephone installations.

Meanwhile the number of shared service stations in the U.K. has risen from approximately 10,750 at the end of 1946 to 80,000 at the present time and there are indications that the 100,000 mark will be passed by the time this article appears in print.

## Reorganisation of Post Office Research

IN 1945, a Government White Paper, Cmd. 6679, was published. This outlined plans for the future employment of scientific research workers in the Civil Service. Reorganisation, into two main classes, commonly known as the "Scientific Officer" and the "Experimental Officer" class was indicated. These would be common to all Government Departments. The structure of the first of these, in particular, differs quite markedly from that of the Administrative Class in the Civil Service, and from that of the Post Office Engineering Class, as it allows suitable officers holding senior posts to continue their individual scientific work without undertaking administrative responsibilities. The staff at other Government research and experimental establishments, such as those belonging to the Ministry of Supply and the National Physical Laboratory, have now been mostly absorbed into the various grades of the new classes. These new classes include engineers as well as chemists and physicists working in the more remote fields of scientific research.

In 1945, also, proposals were first put forward for a substantial increase in the Research Branch so as to enable it to play a greater and appropriate part in the future development of the Post Office system. Indirectly the activities of this Branch may assist British manufacturers to sell improved telecommunication apparatus abroad. Apart from a comparatively small number of officers classified as Chemists or Physicists, the technical staff in the Research Branch had hitherto been carried on the normal Post Office Engineering grades. The advantages of such a method of staffing are obvious; it permits free interchange between the laboratories of the Research Branch, other Headquarter Branches, such as Transmission and Main Lines, and Telephone, where future developments of the Post Office system are planned in the field. The other advantages of the common "Scientific Officer" and "Experimental Officer" classes, however, were such as to justify including within them not only the existing Chemist and Physicist staff, but also engineers engaged on objective fundamental research in such fields as electronics.

The present authorised complement of fully qualified research workers, scientists and engineers, is approximately 50 per cent. greater than in 1945. About one-third of these are scientists, the remaining two-thirds being engineers. Much of the complement in the new grades has been filled by officers in the

Branch whose duties have not been appreciably changed by the fact of reorganisation. As the process of reorganisation has been spread over a considerable period of time (it is not yet quite complete), no dislocation of work has been caused. Shortage of accommodation and the difficulty of getting alterations made to existing buildings so as to make them suitable for the increased staff and the work to be done have been greater embarrassments and of a kind common to other Branches and Departments.

Under the Controller of Research the Branch now has five Divisions. Two of these are "Engineering" Divisions, each directed by a Staff Engineer. In very general terms their respective fields of work are:—

- (i) telephone and telegraph apparatus and mechanisation of postal services [Division R/A],
- (ii) long-line transmission, including communication by submarine cables [Division R/C].

The other three are "Scientific" Divisions, each directed by a Senior Principal Scientific Officer. The work of these Divisions is indicated by:—

- (iii) electronic devices and associated circuitry [Division R/B],
- (iv) materials [Division R/D],
- (v) mathematical and basic physical research; patents [Division R/E].

The general functions of the Research Branch in relation to the Engineering Department as a whole have not been changed; nor does its constitution in five Divisions imply any lack of unity. The organisation has, in fact, been made as flexible as possible so that it may be able to cope efficiently with new and, as yet, unforeseen problems with which it will have to deal, or with changes in emphasis on the different requirements of work to be done.

The activities of the Post Office Research organisation have always extended into fields of national interest allied to communications but not necessarily of direct application to Post Office requirements. Some of these fields have recently been centralised in a separate division, named R/S Branch, under the control of a Staff Engineer, and while not being within the organisation of the Research Branch proper, this Branch enjoys, through the common direction of the Controller of Research, certain common services and facilities, and also has the opportunity for close liaison on matters of mutual interest.

W. G. R.

# A Multi-Channel Radio Telegraph Equipment

G. N. DAVISON, B.Sc.(Eng.), D.I.C., A.M.I.E.E. and  
R. J. PICKARD, B.Sc.(Eng.), Grad.I.E.E.

U.D.C. 621.396.3 : 621.394.441

The latter part of this article is devoted to a description of a two-tone multi-channel voice-frequency telegraph equipment developed by the Post Office for use by the Services on single-sideband H.F. radio circuits employing triple space-diversity reception. A preliminary section of the article tells something of the earlier experiments and development work, and describes briefly the advantages of two-tone and diversity operation.

## *Introduction.*

IN 1941 the Post Office was faced with the problem of providing an alternative to the submarine cable telegraph circuits to North America, to cover their possible loss. A suggestion was made that the required number of telegraph channels could be provided on the Rugby V.L.F. single-sideband radio-telephone connection by the use of standard multi-channel voice-frequency telegraph equipment, operating in much the same way as on a landline, that is, each channel transmitting a tone for a (teleprinter) marking signal and no-tone for a spacing signal. Although multi-channel voice-frequency radio-telegraph operation had only previously been attempted by the Post Office in tests on transmissions over relatively short distances, for example between the Orkney and Shetland Isles, the idea was adopted and, after preliminary tests simulating the conditions of transatlantic operation had been made to test the practicability of the suggestion, the co-operation of the American Telephone and Telegraph Co. was obtained in further experiments.

These experiments, in which the standard European channel spacing of 120 c/s was used, showed that, on the basis of 6-channel operation, Wheatstone and even teleprinter operation was practicable except when the noise crashes experienced on V.L.F. circuits were bad. It was also demonstrated that a further appreciable margin against noise could be achieved by adopting two-tone operation in which two tones having differing but near frequency are transmitted, the one for marking signals and the other for spacing signals.

## *Two-Tone Experiments on H.F. Radio Circuits.*

Early in 1942, with the entry of the U.S.A. into the war, it was decided to extend the experiment to the use of H.F. S.S.B. transmissions and to carry out transatlantic tests with two-tone operation. Tests of Wheatstone operation on six channels proved sufficiently encouraging to allow of channels being set up for traffic within a short time from starting the tests.

The real objective, however, was teleprinter operation, imposing, unfortunately, more severe conditions than Wheatstone working for comparable accuracy. It was found that this accuracy could be achieved under unfavourable radio conditions only by using diversity operation. Four-tone frequency diversity was used, in which each channel transmits two tones simultaneously for marking signals and two others for spacing signals, the diversity depending upon the two tones of a pair being separated as far apart in the V.F. spectrum as the overall design will allow. The first four-tone teleprinter channels were handed over to the service of the U.S. Army late in 1942.

In the middle of 1943 a complete 6-channel, 4-tone equipment of American design, adapted from their standard landline equipment, was shipped to England on behalf of the U.S. Army. This was installed by Post Office staff in Faraday Building V.F. Telegraph Terminal, and, going into the service of the U.S. Army before the end of 1943, continued satisfactorily in use until it was recovered when the U.S. Army left this country after the end of the war.

## *Development for the British Fighting Services.*

In March, 1944, the Post Office began the development, on behalf of the Air Ministry, of the two-tone equipments which are the subject of this article. The design was based on the use of triple space-diversity radio reception, instead of frequency-diversity operation, and was modelled on the two-tone detector already developed by the Post Office Research Branch. The first equipments were required urgently, and had therefore to differ as little as possible from standard M.C.V.F. telegraph design in order to facilitate manufacture. Thus, for instance, the tones were derived from standard multi-frequency generators, and most of the power equipment was provided by the adaptation of available standard plant. The Post Office assumed technical responsibility for the project up to the point of installing the home terminals of the links in a R.A.F. wireless station and co-operating from mid-1945 in tests to Cairo and Delhi, where the installations had been carried out by the R.A.F. in accordance with Post Office instructions. The R.A.F. operated the services on H.F. S.S.B. radio links, the transmitter drive units and the radio receivers being designed and provided by the Post Office Radio Branch. For the further requirements of the Air Ministry, a completely new M.C.V.F. equipment, incorporating oscillators and built-in power packs, was developed for manufacture in bulk. Standard Telephones and Cables, Ltd., have supplied these equipments, to the order of the Post Office, for the War Office as well as for the Air Ministry, and further equipments are now on order for the Admiralty.

## *Principle of the M.C.V.F. S.S.B. System.*

The single-sideband method of radio-telephony and its advantages are well known. One sideband and the carrier are suppressed at the transmitter (or the carrier may be re-injected and transmitted at very low power) so that the remaining sideband conveys the whole of the speech intelligence. If the speech frequencies of telephony are replaced at the sending end by a series of keyed V.F. tones, then the S.S.B. radio receiver will reproduce a similar series of tones, wholly separable by standard M.C.V.F. filters. This

is the basis upon which the system under discussion operates.

#### The Advantages of Two-tone Operation.

In single-tone M.C.V.F. telegraphy, in which the receiving relay is operated by the rectified marking tone opposing a fixed spacing bias, variation of the rectified current causes distortion of telegraph signals. Thus the A.G.C. in the amplifier-detector of the standard landline M.C.V.F. telegraph equipment used in this country enables slow variations of level of the received signals within  $\pm 7.5$  db. of normal to be accepted without the signal distortion becoming intolerably large for teleprinter operation. It was found that this standard equipment could be used for Wheatstone operation, on V.L.F. S.S.B. circuits which are little, or not at all, subject to fading during much of the 24 hours, provided only that the level of noise interference was not too high.

However, in the case of long-distance H.F. transmissions, whilst noise may be less troublesome, very deep fading occurs owing to multi-path reception (with transmission times differing by as much as 2 mS) and to variations in these paths. What is worse, the fading is usually frequency-selective, that is to say at a given instant the signal strength of a particular narrow band of frequencies—say 100 c/s wide—may be of the order of 30 db. less than that of neighbouring bands. The rate of general fading varies considerably but is usually quite slow, whilst the selective fades may occur as frequently as once per second and therefore traverse the pass band of a channel filter in, perhaps, 50 mS. Correction applied in the radio receiver is capable of compensating for general, i.e. unselective, fading, but the effects of selective fading can only be counteracted in the individual telegraph channels.

Two-tone operation offers the following advantages:

- (a) Noise is likely to be approximately equally received in the closely spaced marking and spacing channels, so that a measure of compensation results.
- (b) A.G.C. of the amplifier-detector is simplified as a controlling tone is always present. A common A.G.C. can be designed for the marking and spacing tones, having a wide range of control of the order 50 db. and a very short time-constant, such as 10 mS, to enable it to follow deep and rapid fading. It is arranged that when, for instance, a strong marking signal is being received, the common A.G.C. reduces the gain of the marking channel and at the same time reduces that of the corresponding spacing channel to suppress noise in it.
- (c) As the corresponding marking and spacing tones are closely spaced, say for example, 660 c/s and 780 c/s respectively, they are likely to be similarly affected by moderate selective fading, and this is borne out in practice.

#### Diversity Operation.

The simple two-tone arrangement is satisfactory in most circumstances for Wheatstone operation, but when the selective fading is very severe, that is when

the depressed frequency band at any instant is very narrow and the fading deep, diversity operation has advantages. In four-tone operation one or other of the diversity-pair of tones, for example, 660 c/s and 1380 c/s, is always likely to be sufficiently strong for good reception, and can be arranged to take charge for the time being and suppress the amplifier of the weaker frequency which otherwise would amplify unwanted noise at high gain. It will be apparent that this improvement, which makes satisfactory teleprinter operation realisable, is only achieved by halving the number of complete channels that can be accommodated in a given frequency band.

Another way in which similar advantages in quality of reception can be obtained, using only the bandwidth of two-tone operation but complicating the radio receiving equipment, is the employment of double or triple space-diversity radio reception, in which two or three widely spaced antennæ with separate radio receivers are required. Each receiver is connected by a separate landline to a two-tone M.C.V.F. telegraph receiving equipment, and (considering any one channel of a triple-diversity system), the M.C.V.F. detector receiving the strongest signal at a given instant controls the telegraph receiving relay, and the weaker signals in the other two detectors are rejected. The necessity for three independent lines between the radio receivers and the M.C.V.F. equipment is a slight disadvantage if they are situated far apart. Triple space-diversity operation was adopted for the Services system.

#### Development of the Two-Tone Detector.

The first two-tone detector developed by the Post Office for the V.L.F. tests had A.G.C. with a time-constant of 150 mS and covered level changes of 30 db. This of itself was not thought adequate to deal with the depth of fading expected on H.F. reception, and it was decided, for the early H.F. tests, to precede the detector by an amplifier-limiter of a type proposed by the A.T. & T. Co., necessitating the use of additional filters. The general arrangement is shown in Fig. 1. It was found in practice that the

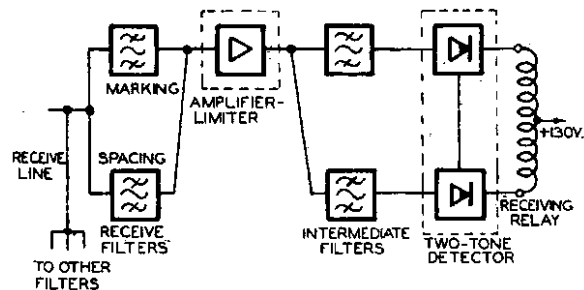

FIG. 1.— EARLY TWO-TONE ARRANGEMENT FOR H.F. TESTS.

presence of pre-limiting, even in local test, caused the telegraph distortion to be high—of the order of 10 to 12 per cent.—although there was little further increase with severe fading and, moreover, the pre-limiting is of advantage when the signal-to-noise ratio is very low. In view of the objection to the high distortion, however, the first two-tone channels set up for H.F. morse operation in July, 1942, employed the

two-tone detectors only, the general arrangement being as shown in Fig. 2, and it was decided to proceed

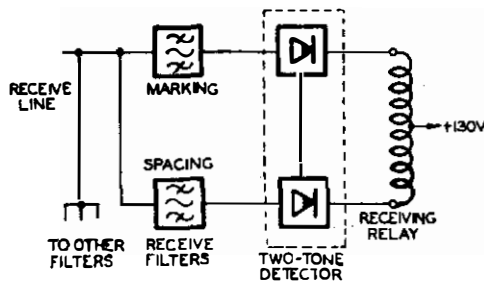

FIG. 2.—ARRANGEMENT OF EXPERIMENTAL H.F. TWO-TONE OPERATIONAL MORSE CHANNELS.

with the development of this arrangement. A new design of amplifier-detector was produced having A.G.C. with a time constant of 10 mS, capable of handling fades of 50 db. This detector has remained virtually unchanged in the latest equipments, except for the introduction of automatic grid bias. A description of the detector is given later.

#### Present Two-Tone Triple-Diversity Equipment.

As mentioned earlier a number of 6-channel equipments were manufactured urgently for the Air Ministry and an interim design had to be used, description of which would be superfluous.

As soon as the manufacture of these early equipments had been started, a completely fresh design was begun. The design was again for a 6-channel, two-tone, triple space-diversity equipment, but one employing oscillators, self-contained power packs for A.C. mains and more appropriate testing equipment. The best possible layout on 7 ft. 6 in. high bays, for both ease of maintenance and economy of space, was sought, and tropical finish was specified. The sending and receiving channel equipment for a complete system was accommodated on three bays, and an additional common equipment and test bay was designed to serve two such equipments in anticipation of there being many stations requiring two systems. Hermetically sealed filter units were adopted, which occupy little space and are also free from the troubles caused by humidity in tropical countries. A careful study was made of the temperature/frequency stability of these filters, and also of the channel oscillators, since signals generated at one station under a rising tropical sun might well have to be received half way round the world under an icy moon with, however, the reasonable expectation that the conditions inside the buildings would never be extreme. The desirability of locking the channel oscillators to a common master oscillator was also studied. It might appear that by using frequency-locking only the master oscillator need have the desired stability. But to cover its failure, either a second master

oscillator would have to be switched into use, or the channel oscillators themselves must have the requisite stability. It might also appear that with frequency-locking it might be possible to eliminate the worst peaks in the composite wave-form of the six channel audio outputs. This would allow the power of the radio transmitter to be used to best advantage. However, no such advantage can be guaranteed due to phase changes arising in the audio line to the transmitter. Relative phase shifts can also occur between the channel oscillator outputs, due to the drift of their natural frequencies from those to which they are locked. The latter difficulty might have been overcome by providing phase-, as well as frequency-locking, but it was decided that free oscillators would suffice.

The connections required between the V.F. equipment and the telegraph instruments, radio transmitter and radio receivers are shown in Fig. 3. It was expected that the V.F. equipment would usually, though not necessarily, be accommodated at the

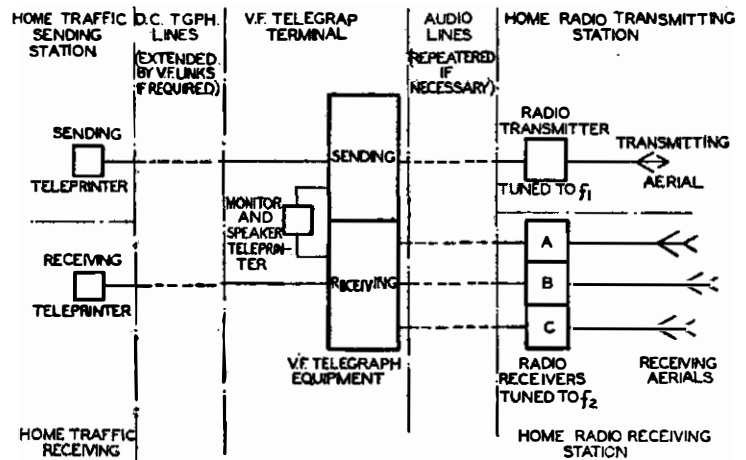

FIG. 3.—LAYOUT OF SINGLE-SIDEBAND RADIO TELEGRAPH SYSTEM.

radio receiving site. For the maximum economy in lines with all possible arrangements it would have been necessary for the V.F. sending and receiving equipments to be separable, but a decision was taken to keep them always together for ease of control and maintenance.

A block schematic diagram of the V.F. telegraph equipment is shown in Fig. 4. On the sending side each of the six sending instruments, usually teleprinters, controls the output of two oscillators by means of two modulators, connected in opposite sense so that while one passes tone the other suppresses it. The Morse relay, controlled by a Morse key, can be made to short-circuit the send transformer secondary, a facility required in lining up the radio circuit but also available for providing Morse signalling as a last resort when radio conditions are too bad for any kind of teleprinter sending. The 16 db. pads at the sending and receiving ends are used in connection with the reduction of the number of working channels from six to one under bad radio conditions, the one selected channel transmitting at increased power.

On the receiving side, it is not until after the

rectification of the three diverse signals by diodes in the three separate two-tone detector panels that they are united for amplification by a common pair of D.C.

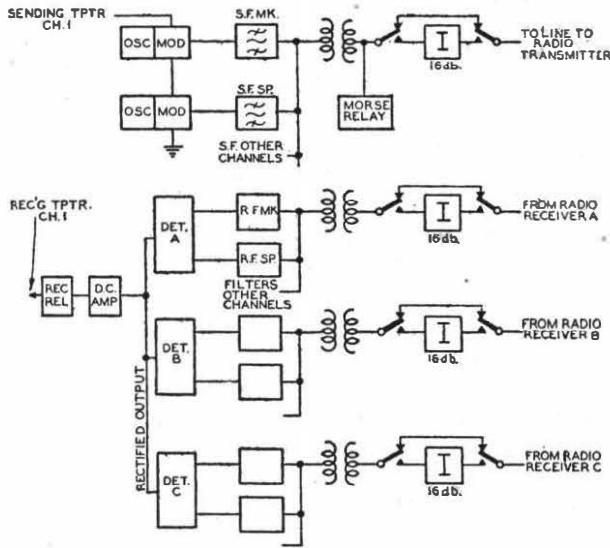

FIG. 4.—BLOCK SCHEMATIC DIAGRAM OF V.F. TELEGRAPH EQUIPMENT FOR TRIPLE-DIVERSITY S.S.B. OPERATION.

amplifier valves in push-pull to drive a single receiving relay.

Fig. 5 shows the front of the common bay and three

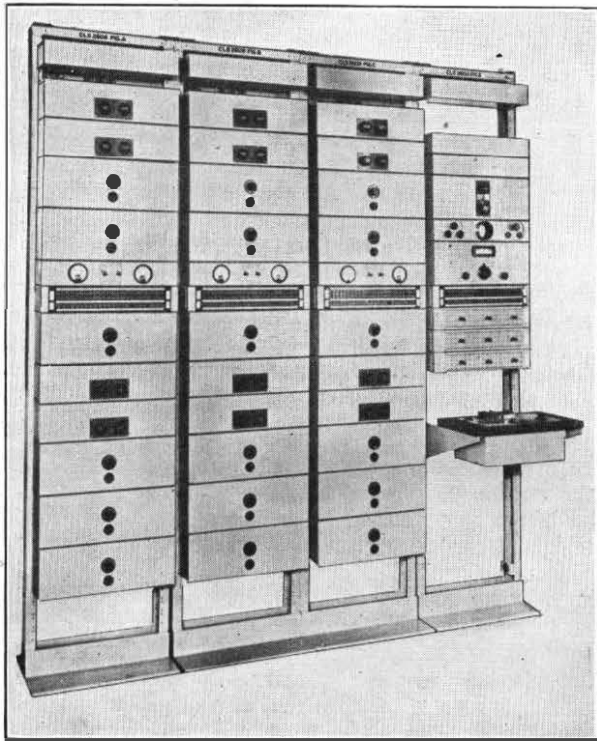

FIG. 5.—FRONT VIEW OF EQUIPMENT.

channel bays which together form a complete system. The common bay, which will serve two systems and then becomes the central bay of seven in line, accom-

modates not merely the test gear but also the line transformers, attenuators, etc., for the two systems. Each channel bay accommodates the complete triple-diversity equipment for two channels, a more convenient arrangement than that which was used for the earlier generator-type equipment. The compact layout of the panels can be seen from Fig. 6

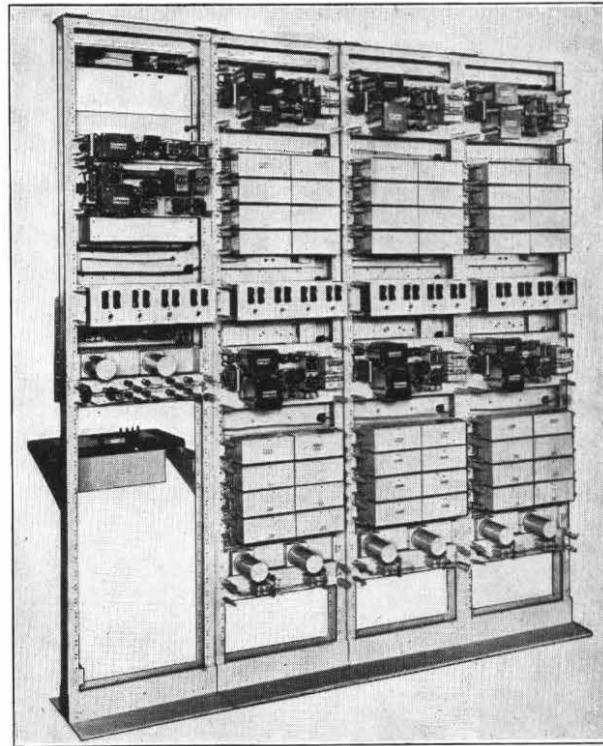

FIG. 6.—REAR VIEW OF EQUIPMENT.

which shows the rear of the equipment with dust covers removed. The following are brief details of the apparatus:—

*Power Units.* Each channel and, in general, each item of test gear is provided with a separate power unit. The power units are of conventional design and incorporate selenium rectifiers.

*Oscillator-Modulator.* The channel oscillator and modulator occupy a single panel, shown diagrammatically in Fig. 7. The oscillator valve is a pentode, type EF.37. The fine control C2 provides 10 steps each effecting a frequency change of approximately 2 c/s. The output waveform is roughly square, a feature which results from the design for stability, but this is unimportant as the send filters attenuate unwanted harmonics.

The double-current D.C. signals from the sending instrument are applied to terminals 1 and 2 of the modulator. When terminal 1 is negative with respect to 2, bridge W2 conducts tone from transformer T2 to transformer T3, while bridge W1 forms a high impedance across transformer T2. Conversely, when terminal 1 is positive bridge W1 becomes conducting to the A.C. tone and applies practically a short-circuit to transformer T2, while at the same time bridge W2 offers a high impedance to the passage of

tone to transformer T3. The suppression is at least 35 db., and usually over 50 db. for any value of D.C. control current between 15 and 25 mA. A complete

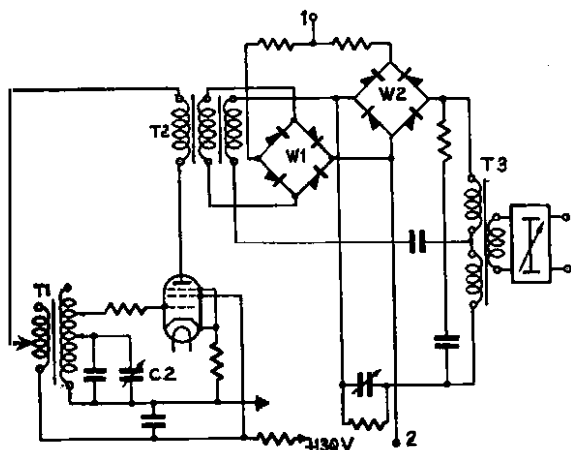

FIG. 7.—OSCILLATOR MODULATOR.

channel equipment comprises two oscillator modulators, the D.C. control circuits of the two modulators being connected in opposite sense in series.

**Detector.** The circuit of the two-tone detector is shown in Fig. 8. Valves V1 and V2 are Class A ampli-

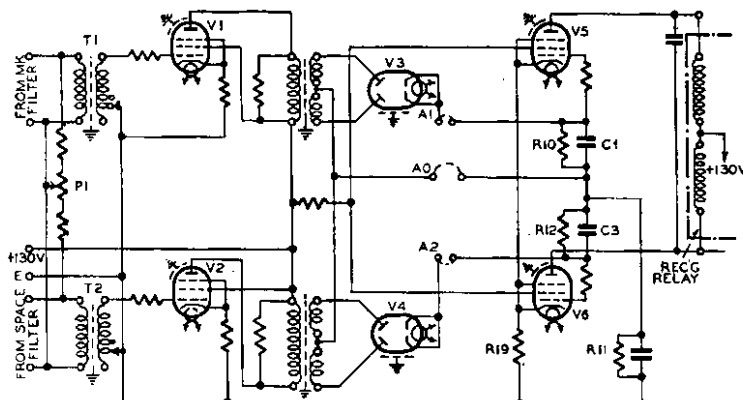

FIG. 8.—TWO-TONE DETECTOR.

fiers (type S.P.41), with a small degree of negative feedback in that their cathode resistors are unshunted. In the absence of noise in the received signals, tone is applied to V1 or V2 but not to both simultaneously. Valves V3 and V4 are double-diode detectors (type E.B.34), with load circuits R10, C1, and R12, C3, respectively. For a normal marking signal, rectified current from V3 flowing in R10 applies a positive potential to the control grid of the D.C. amplifier valve V5 (type S.P.41), causing V5 to conduct and grid current to flow. The anode current flowing in R19 provides automatic bias for V5 and cut-off bias for V6. Grid current flowing in R11 limits the anode current in V5 and biases V6 beyond cut-off to ensure that any noise in the spacing side does not cause anode current in V6, except when the noise is so great that the input to T2 exceeds that to T1. The anode current in V5 operates the receiving relay to the marking

condition. The limiting action of the grid current in R11 permits satisfactory operation being obtained with signals varying from +5db. to -45db. relative to 1 mW.

Potentiometer P1 is used to correct for bias in the receiving circuit, including the detector itself. Three detectors are combined to make a triple-diversity set by commoning points A<sub>0</sub>, A<sub>1</sub> and A<sub>2</sub> on all three detectors and using valves V5 and V6 in only one of the three. The double-diode producing the greatest signal at any instant assumes control of the output stage.

**Receiving Relay.** The receiving relay is similar to the Post Office Relay No. 299AN but has tropical finish and a radio interference suppressor incorporated.

**Test Gear.**

**Standard Oscillator and Oscilloscope.** The use of channel oscillators demands frequency checking facilities. The sub-standard for the check is a 120 c/s oscillator, which provides a circular time base for a small oscilloscope, the whole being mounted on the common bay. The oscillator is of the lamp-bridge design first described by L. A. Meacham<sup>1</sup> and having the advantages of great stability of both frequency and amplitude of output, and also of almost purely sinusoidal output wave-form. In the present application the stability of amplitude is not important, but the pure sine-wave output is necessary for a simple circular time base, and frequency stability is obviously essential. The latter was achieved by careful design of a stable coil and condenser combination. As the frequencies to be checked are all odd multiples of 60 c/s, a 60 c/s test oscillator would have been preferable, but it could not be simply designed to have the requisite frequency stability. The channel frequency under observation modulates the trace in the oscilloscope, and a stationary figure indicates correct frequency.

**Transmission Measuring Set.** A transmission measuring set of conventional design is provided for the purpose of measuring signal levels at various test points in the system.

**Relay Test and Signal Generator Panel.** A test panel is provided on the common equipment rack, serving the double purpose of enabling the receive relays to be tested and accurately adjusted and of generating telegraph reversals at approximately 34 bauds for channel testing. The circuit of the tester is extremely ingenious, but a description of it would necessarily be very lengthy. Therefore only an indication can be given of the facilities provided. In testing a relay the following sequence of tests is applied in the twelve positions of a rotary switch, the observations being made on a meter:—

1. Operate to mark.
2. Hold to mark (with a very small spacing current).

<sup>1</sup>B.S.T.J., Vol. 17, No. 4.



3. Saturate to mark.
4. Operate to space.
5. Hold to space.
6. Saturate to space.
- 7 to 12. All of the above repeated.

For adjusting relays a self-vibrating "bias" test is available. While the relay reverses continuously by the interaction of its contacts and a resistance-condenser network its magnetic circuit can be adjusted to neutrality. Neutrality alone is not a sufficient criterion, and a "frequency" test is also provided. This test covers the adjustment of the magnetic flux, and to pass the test the pole-pieces must be set near to their optimum positions.

To transmit reversals an adjusted relay is placed in the tester, set for the "bias" test, and the output from the relay is connected by plug and cord to the relay under test. Received reversals can be patched for observation on the meter of the tester, simultaneously with transmission of reversals if desired.

#### *Testing and Maintenance.*

A detailed statement of the testing and maintenance arrangements is outside the scope of this article, but a few points of interest are described in the following paragraphs.

*Six-Channel and Single-Channel Facility.* The facility of transmitting only one tone, or channel, instead of six, and of raising the level of this tone by 16 db., is useful for purposes other than that of gaining a higher signal-to-noise ratio in times of bad radio propagation. One tone is transmitted for the lining-up of the radio transmitter; and one tone is also better suited to Morse working than six tones as it is a much more usual signal for the recipient to interpret. In a single-sideband system, however, where the transmitter power is governed by the signal power, precautions must be taken in changing from six- to single-channel working, or vice versa. The five unwanted tones must be suppressed before the level is raised, or conversely the level must be lowered before the five extra tones are added, in order that the transmitter shall not be overloaded.

The recommended order of operating as the radio link deteriorates is (1) 6-channel teleprinter, (2) single channel teleprinter, and (3) Morse. Condition (2) is found to be little used in practice, but the single-tone facility is justified as it is used for both (2) and (3). This, however, presents the problem of preventing the idle teleprinters in the five unused channels from "chattering" due to spurious operation of the detectors on radio noise. If single-channel working is in use both ways on the same channel, this is easily overcome by the operation of the other five mark-space keys which "loop" the D.C. send and receive lines. But if six channels are in operation in one direction and only one in the other, as sometimes occurs, then the chattering must be stopped by other means. In this case the flow of current in the spacing coils of the appropriate receive relays is prevented by disconnection plugs in the "rectified current" jacks.

*Distortion Tests.* Partly because it is more economical of circuit time, and partly because there is little,

if any, advantage to be gained from the practice, the telegraph equipment is not tested over the radio link. All the tests are made "in local". To do this a system-looping network is provided which divides the sent signal equally between the three receiving equipments.

As with most A.C. telegraph systems the only distortion which can be corrected in the normal course of maintenance is bias distortion. The detector panels with their range of about 50 db. require a wide variation of input level to ensure a real test, but to avoid additional test gear the 16 db. pads already provided are used to give an input range of 32 db. The detectors are tested separately and the bias potentiometers adjusted with one 16 db. pad between send and receive sides. The panels are then checked to ensure that no serious bias is introduced either when the level is raised or lowered 16 db., or when the three panels proper to a channel are combined.

*Oscillator Checks.* A facility which though seldom required may occasionally be invaluable, is that of a station-to-station frequency check. A certain station may suspect its 120 c/s standard oscillator, or the frequencies being transmitted to it by a distant station. In such a case, a received signal may be patched from the output of the receiving filter to the oscilloscope, and the design of this tester is such that the signal will give a readable modulation under average radio conditions. By transmitting a "guaranteed" 1,020 c/s signal (over channel 3 "space") for example, the distant 120 c/s oscillator can be checked. Alternatively any incoming signal may be observed for frequency on the receiving-end oscilloscope.

#### *Conclusion.*

As radio circuits vary so much, according to the relative geographical positions of the stations and to the prevailing propagation conditions, it is impossible to generalise upon the proportion of the day in which the system is likely to be fully effective on all channels, but at least the multi-channel S.S.B. system compares well with competing methods of operation. For the transatlantic system, operating with frequency diversity, an extract of the log was made for two weeks in every three months over a period of fifteen months, and the average daily record of these six periods was 19.3 hours service on all six channels plus 1.2 hours on one channel only, the circuit being closed for a fixed two-hour period every morning. The authors have not access to similar information for any of the circuits operating with the triple space-diversity equipment, but it can be safely assumed that their performance would be not worse under similar conditions.

#### *Acknowledgments.*

It will be realised that many officers of the Research, Radio and Telegraph Branches of the Engineer-in-Chief's Office have been concerned with this development and have contributed directly or indirectly to the material of this article. Thanks are also due to Standard Telephones and Cables, Ltd., for help given and for permission to use their photographs of the equipment.

# C.C.I.(F.) Meeting, Stockholm, June 1948

U.D.C. 061.3 : 621.395.06. 620.193

A NUMBER of Commissions of the C.C.I.(F.) met in Stockholm over the period 7th-22nd June, 1948. The discussions covered a wide field, including administration, operating and tariff matters as well as many engineering questions. These notes review the matters of direct engineering interest which were dealt with. The matters fall into two classes, the first being concerned with the European Switching Plan and the second with questions of cable corrosion.

## *The European Switching Plan.*

It will be recollected that the development of this plan is entrusted to a Mixed Commission<sup>1</sup> which unifies the activities of the 3rd, 6th and 8th Commissions, and the Sub-Commission for Demand Working. One of the main outstanding problems is to agree upon a signalling system, and arrangements are being made to hold a field trial<sup>1</sup> to give guidance on some outstanding points of difficulty, and, in particular, to enable a choice to be made between a system employing one frequency only, and a system making use of two signalling frequencies. At Stockholm it was hoped to obtain agreement between all parties on the facilities to be given for the field trial, and especially on the following points:—

- (a) the method of dealing with *pré avis* calls,
- (b) the extent and method of use of alternative routing,
- (c) the methods to be employed for delay working,
- (d) the facilities and signals required when it is necessary for an operator setting up a call under semi-automatic conditions to make use of the services of another operator at another point in the connection.

Common discussions took place at Stockholm on the above questions. A strong feeling emerged that there was an urgent need (in view of the difficulty of obtaining qualified operators and accommodation) for relieving incoming operators and freeing incoming positions, by providing dialling facilities from a switchboard at one international centre merely to subscribers in the local area of a second international centre directly connected to the first. It was also felt that in view of the lack of experience of semi-automatic working in the international field, it was not possible at this stage for definite decisions to be made regarding operator methods and facilities required where a comprehensive tandem switching scheme is in question. It was finally decided that the equipment for the dialling trials should be designed with the main object of bringing about as rapidly as possible the standardisation of signalling and switch-

ing equipment for direct operator-dialling as defined above. This does not rule out the provision in the trial equipment of means for trying out more extensive facilities if these can be included without appreciable additional complication or delay.

Operating and other questions on which decisions could not be reached at Stockholm were left for consideration by the appropriate Commissions. For example, on the question of alternative routing, it seems possible that considerable economies can be effected by allowing two transit centres in an international call instead of one as at present laid down. This was one of the points made by the American Telephone & Telegraph Co. during the 1947 study trip.<sup>2</sup>

During the Stockholm meeting, a decision was taken by the Administrations of Sweden, Denmark and Norway, to put in hand a series of dialling trials on lines connecting these three countries. This development will be watched with great interest, and arrangements have been made for the working party concerned with the trials to be extended to include representatives of Norway and Denmark (Sweden was already represented).

## *Cable Corrosion.*

The 1st C.R. did not meet this year as further time was needed for progress to be made with the questions discussed in Paris in 1947.

The work of the 2nd C.R. was confined to that of the committee undertaking the preparation of recommendations for Protection against Chemical Corrosion. The provisional plan agreed upon in Paris in 1947 envisaged seven chapters dealing with different kinds of corrosion and the mechanism of corrosion; cable sheaths; coverings and armouring; conduit systems; means of distinguishing between different kinds of corrosion; and the physico-chemical and bacteriological characteristics of soils. The first drafts of these chapters—three of which were prepared by the British Post Office—were discussed and co-ordinated and a good measure of agreement reached on the revised drafts which are to be further studied for discussion.

Our Swedish friends did everything possible to ensure the delegates' comfort and interest. An excursion was organised to the L. M. Ericsson works in Stockholm which was most enjoyable and instructive. A further trip to Mariefred and Västerås included a visit to the old castle of Gripsholm, and an inspection of Västerås automatic exchange which is interesting in that crossbar-type registers are being fitted in a 500-point selector exchange. Many thanks are due to the Swedish Administration for the excellent and complete arrangements made for the Reunion.

H. W.

<sup>1</sup> P.O.E.E.J., Vol. 41, p. 50, and C.C.I.F. Document, "Programme Général d'Interconnexion Téléphonique en Europe."

<sup>2</sup> P.O.E.E.J., Vol. 41, p. 50.

# Fifth Plenary Meeting of the C.C.I.R., Stockholm, July, 1948

U.D.C. 061.3 : 621.396

THE duty of the International Radio Consultative Committee (C.C.I.R.) is to study technical radio questions and operating questions, the solution of which depends principally on considerations of a technical radio character, and to issue recommendations on them. Thus the terms of reference differ from those of both the C.C.I.T. and C.C.I.F. since they are confined to technical matters and do not include operating and tariff questions. The fourth plenary meeting of C.C.I.R. took place at Bucarest in 1937 and it was proposed that the fifth meeting should be held at Stockholm in 1942. However, the intervention of the war made such a meeting impracticable and it was not possible to hold the fifth meeting prior to the International Telecommunication and the Radio Regulations Conferences held at Atlantic City in 1947.<sup>1</sup> This was

radio noise, standard frequency and time signal transmissions, international monitoring of radio transmissions, marine radio, radiophoto transmission and broadcasting. Reports outlining the conclusions reached were circulated to the Chairmen of the six international study groups and the U.K. delegation travelled to Stockholm for the formal opening of the fifth C.C.I.R. on 12th July, 1948. A total of 34 nations was represented at the meeting which was held in a hotel in the centre of the capital. The accommodation included two lounge rooms provided with simultaneous translation facilities and several smaller rooms for which successive translation facilities were available. The proceedings were under the able chairmanship of Dr. Sterky, Swedish Administration, and the work was carried out by ten committees as outlined in Fig. 1. These comprised organisation,

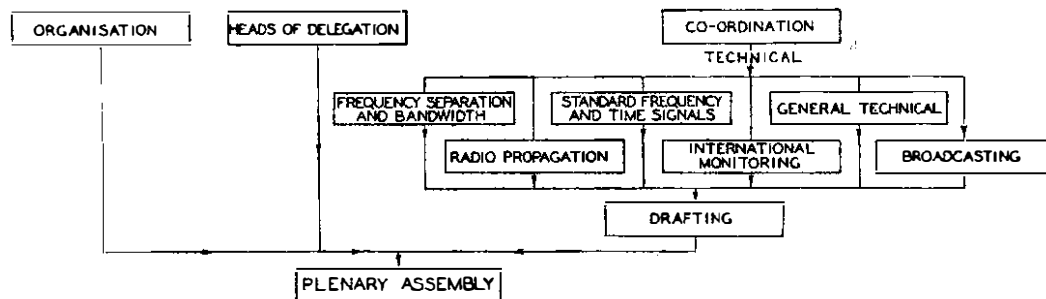

FIG. 1.—ORGANISATION OF COMMITTEES.

unfortunate since it was not possible in the Atlantic City deliberations, during which the reallocation of the radio frequency spectrum was undertaken, to take full advantage of up-to-date C.C.I.R. studies. The importance of such studies was fully appreciated at Atlantic City where it was recommended by the International Telecommunications Conference that the fifth C.C.I.R. should be held at Stockholm in 1948. In addition, it was decided to strengthen the C.C.I.R. by the election of a full-time Director and Vice-Director and by the provision of a permanent secretariat. The period of eleven years which had elapsed since the Bucarest meeting was one in which major advances were achieved in radio communication and, in consequence, the fifth C.C.I.R. was important in respect of the resulting technical advice which could be made available to members of the International Telecommunications Union (I.T.U.), to the International Frequency Registration Board (I.F.R.B.) and to the Provisional Frequency Board (P.F.B.).

Preparatory study groups were set up in the United Kingdom in February, 1948, to examine the outstanding Bucarest questions requiring further study and also the new questions posed at Atlantic City. All aspects of radio communications were concerned and the six study groups considered respectively the bandwidths of transmissions, radio propagation and

heads of delegation, co-ordination and drafting committees and six technical committees. The six technical committees, on which fell the burden of making the technical recommendations, were in general under the chairmanship of the chairman of the international study groups who had been nominated at Atlantic City. Their work was broken down into sections for study by sub-committees and working groups and these were fully occupied in making technical recommendations for submission to the drafting committee and then to the plenary assembly. Simultaneously the other committees were concerned with the organisation of the fifth C.C.I.R., the election of the Director and Vice-Director and with the organisation of the preparatory studies for the sixth C.C.I.R.

It is not possible in this brief survey to discuss in detail the work of the technical committees and it is proposed merely to outline some of the more important items. Some progress was made on the effective bandwidths required for the various types of transmission on which more detailed information is required in connection with the reallocation of the radio frequency spectrum now being undertaken by the P.F.B. and I.F.R.B. at Geneva.

Several problems associated with the accurate forecasting, over the complete sunspot cycle, of the optimum frequencies for all types of radio links were examined. Recommendations on the provision and

<sup>1</sup>P.O.E.E.J., Vol. 40, p. 175.

siting of additional ionospheric recording stations throughout the world were made and the need for additional measurements of radio noise was stressed. The exchange of information on ionospheric data and noise on an international basis will be facilitated by proposals to standardise the nomenclature.

The form of standard frequency and time signal transmissions for future use was generally agreed. The difficulties in connection with the simultaneous operation of several transmissions on the same nominal frequency were analysed and a preliminary study was made of the number and siting of the stations necessary to provide a world-wide service of high accuracy. It is proposed to carry out international tests before the sixth C.C.I.R. to provide practical information on the limitations set to simultaneous operation on a common frequency by

recommendations on the words to be used as signals of distress and urgency were approved. The design of an automatic distress watch receiver was not completely evolved and it was decided to make field trials of two sets, developed by the United States and the United Kingdom respectively, before making a final recommendation.

Several questions on sound and television broadcasting were examined, but in general it was not possible to make final recommendations and they were remitted for further study.

As a result of the work of the technical committees a large number of technical recommendations and new questions were approved. The elections of the Director and Vice-Director were carried out, Dr. Van der Pol will take up the post of Director on 1st January, 1949, and Mr. L. W. Hayes that of the

#### INTERNATIONAL STUDY GROUPS

No.	TITLE	CHAIRMAN
1	Radio Transmitters .. ..	Dr. E. Metzler (Switzerland)
2	Radio Receivers .. ..	Dr. P. David (France)
3	Radio Systems .. ..	Dr. H. C. A. van Duuren (Netherlands)
4	Ground Wave Propagation ..	Professor L. Sacco (Italy)
5	Tropospheric Propagation ..	Dr. R. L. Smith-Rose (United Kingdom)
6	Ionospheric Propagation ..	Dr. J. H. Dellinger (United States of America)
7	Standard Frequency and Time Signal Transmissions ..	Dr. B. Decaux (France)
8	International Monitoring ..	M. J. Ehrlich (Czechoslovakia)
9	General Technical Questions	Mr. C. F. Booth (United Kingdom)
10	Sound Broadcasting ..	Mr. Burton (United States of America)
11	Television Broadcasting ..	M. E. Esping (Sweden)
12	Operation (Depending on technical factors) .. ..	M. J. D. H. van der Toorn (Netherlands)
13	Tropical Broadcasting ..	M. M. S. S. Rao (India)

impairment of accuracy of the received signal due to mutual interference. It was also decided that whatever the finally agreed form of transmission, the transmission should cease for a few minutes every hour to enable radio noise measurements to be made on all standard frequency allocations, and thereby to provide the additional noise data so urgently required for circuit planning.

In discussion on the international monitoring of frequency transmissions, so important to the effective exploitation of the radio frequency spectrum, agreement was reached on the accuracy and technique of frequency measurement. Further studies will be made of the problems associated with field strength and bandwidth measurements.

On the standardisation of radiophoto equipment it was agreed that sub-carrier frequency modulation should be used but the question of drum size and speed, together with associated factors was referred back for study in co-operation with the C.C.I.T.

Among the marine radio questions, technical

Vice-Director. At the final plenary session 13 international study groups were created in accordance with the table, to carry out studies preparatory to the sixth C.C.I.R.

The United States of America, France, Netherlands and the United Kingdom have each provided two chairmen, and Czechoslovakia, India, Italy, Sweden and Switzerland one each.

At the closing session it was agreed to accept the invitation of the Czechoslovakian Administration to hold the sixth C.C.I.R. at Prague in the late Spring of 1951.

In conclusion it should be recorded that the Swedish Administration assured the success of the fifth C.C.I.R. by the excellent organisation preparatory to, and during, the meeting. This organisation included both the technical and social side, and the Administration proved a perfect host, taking care that delegates found some time to enjoy the renowned Swedish hospitality in the very beautiful capital city.

C. F. B.

# Telecommunications for the 1948 Olympic Games

E. R. SMITH, A.M.I.E.E.  
and C. W. SALLNOW

U.D.C. 654.1 621.394/7 796/8

A brief description of the communications provided by the British Post Office for the XIV Olympiad.

## Introduction.

THE XIV Olympiad held in London during August, 1948, called for considerable effort on the part of the Post Office to provide communication facilities for the management and control of the "Games", the rapid distribution of the results of events and for postal, telephone and telegraph services for contestants and the general public.

Facilities were required at Wembley, the main venue, and at the White City, Earls Court, Herne Hill, Finchley Baths, Harringay Stadium, Windsor Great Park, a number of football grounds in London and at centres in the Home Counties and South-Western Regions. Communication services for the use of contestants housed in camps and billets in various parts of the country were also needed.

The work involved included the provision of a new telephone exchange operating as a P.M.B.X. for the main venue; Continental and Overseas booking suites; an International telex service for the Press; local networks for the control of events by the Arena Manager; a teleprinter network for the circulation of results; a large number of programme circuits, control circuits and microphone points for the B.B.C. for audio and vision broadcasts; and additional exchange lines, private wires, kiosks and call offices at all venues for the use of the organisers, other interested bodies and the general public.

It was realised at an early stage that the requirements were such that concentration of circuit ter-

minations would result at Wembley and in Central London and that existing equipment and line plant would need augmenting.

## Corinthian Exchange.

The main structure of the building for Wembley automatic exchange was well advanced by January, 1947, but it was evident that the automatic equipment could not be installed and ready for use in time for the relief of Wembley manual exchange. It was decided, therefore, to install a temporary manual relief exchange in the semi-basement of the automatic exchange building. Requirements for the Olympic Games rapidly took the form of firm demands and it was considered that one large P.M.B.X. with full exchange facilities would be preferable to a number of separate switchboards for each organisation concerned. Exchange line accommodation on the already overloaded local exchange was impracticable and it was decided, therefore, that the temporary exchange in the automatic exchange building should be equipped for Olympic Games requirements. Subsequently, the temporary exchange was to be used to provide relief to the Wembley exchange area.

The exchange, aptly named Corinthian, was installed by local Post Office staff and has a multiple capacity of 2,800. The general layout and face equipment of the switchboard is shown in Fig. 1. Calling equipments for 1,200 subscribers were provided initially, the switchboard consisting of 21 C.B. No. 1 positions including 3 C.C.I. positions. 260 o/g and 181 i/c junctions, a supervisor's desk, two monitoring positions and a test desk were provided.

The whole of the installation, the equipment for which had to be reconditioned, was completed in nine months and the exchange successfully brought into service on the 10th May, 1948. Apart from a few public circuits, service was given to 356 exchange lines associated with the Olympic Games. In addition, a block of 20 auxiliary numbers on Corinthian 2,000 was provided for use as an official enquiry bureau. A large number of the enquiries dealt with were from overseas visitors wishing to locate competitors and officials associated with events.

## LINE PLANT AND CIRCUITS

The exceptionally heavy demands for circuits made necessary, in addition to the utilisation of spare plant, the provision of new cables, and rearrangements of existing cables, to make pairs



FIG. 1.—CORINTHIAN EXCHANGE—PART OF SWITCHBOARD

available where required for B.B.C. programme transmission and control circuits, telephone and telegraph private wires and continental, overseas and telex circuits.

In the light of the known circuit requirements and from an examination of the available plant on the cable routes concerned, it was seen that additional local line plant would be required in the Wembley and Central London areas, and additional junction cable pairs between Wembley and Central London.

*Local Line Plant.*

To cater for the B.B.C.'s circuits terminating in Broadcasting House, cable pairs already provided for the Langham exchange transfer scheme were extended into Broadcasting House, making available 200 outlets to Museum which, together with existing spare pairs to other exchanges and the normal service on Welbeck exchange, were considered sufficient.

At Wembley, approximately 3.4 miles of duct (varying in size from single-way to nine-way) was laid on the cable route from Corinthian exchange to a building known as the Civic Hall and for distribution to other buildings in the Stadium grounds. Two main cables were provided from the exchange to the Civic Hall, one 1100 pair/10 and one 540 pair/20. These cables together with the local cables to other buildings were terminated on a distribution frame to provide a flexibility point for the distribution of

circuits as required. Arrangements will later be made to utilise a large proportion of this plant for subscribers' services.

Small construction works were also necessary in other localities, including the rearrangement of junction cable pairs and the provision of three 14-pair buried cables in Windsor Great Park, the latter for use in connection with the Cycle Road Race.

*Trunk and Junction Line Plant.*

Preliminary planning of a new junction cable between Museum exchange and Wembley automatic exchange had commenced in 1946, the cable being required for Wembley transfer and for the relief of existing junction plant. As the B.B.C.'s requirements included the provision of circuits from Wembley to Museum and Faraday Building for television broadcasts, it was decided to provide both audio pairs and coaxial tubes in one cable and the audio pairs were distributed so that on completion of the Games they would be available at exchanges on the route to meet junction circuit growth.

A 2/370 D.T.I. + 16/20 P.C.Q. + 468/20 P.C.Q.T cable, 308 pairs of which were loaded, was supplied and installed by Standard Telephones and Cables Ltd., between Museum and Corinthian exchanges and a 2/370 + 16/20 P.C.Q. cable from Corinthian exchange to the Royal Tunnel, Wembley Stadium. One of the tubes was extended from the Stadium to the Empire Pool. Spur cables were provided into Cun

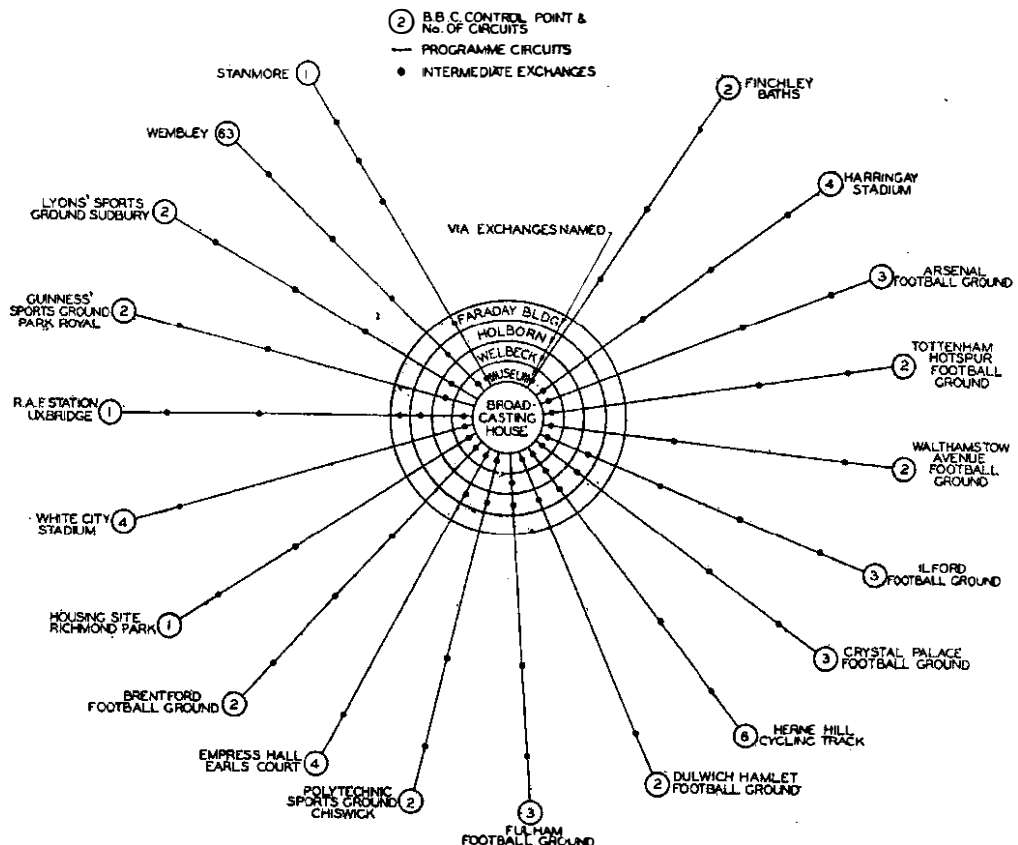

FIG. 2.—B.B.C. PROGRAMME CIRCUITS (NON-AMPLIFIED).

ningham, Ladbroke and Elgar exchanges so that the coaxial tubes (plus a number of audio pairs) could be taken in and out of these intermediate exchanges for the insertion of mobile repeater equipment. A network of coaxial and balanced pair cables was provided between the Stadium, Pool and the B.B.C.'s control room in the Palace of Arts for television control. To afford protection against the weather the coaxial tubes were terminated in the Royal Tunnel and at the Empire Pool in specially designed terminating boxes. For the vision broadcasts the circuits were repeated at Museum, Ladbroke and Corinthian exchanges, this repeater equipment, the amplifying and modulating equipment at the Palace of Arts and the modulator at Museum exchange being provided by the Post Office.

The demands for circuits to be routed via the trunk network and from various locations to Press and cable companies' offices in the City required more than the existing number of spare high-grade conductors between Museum exchange and Faraday Building; 308 20-lb. loaded pairs were therefore included in the Faraday-Museum section of the new London-Birmingham coaxial cable and arrangements were made for the contractor to complete this particular section of the cable in time for routing Olympic Games circuits.

**Circuit Provision.**

Included in the work carried out to enable the B.B.C.'s extensive programme circuit arrangements to be set up—Figs. 2 and 3 show the programme

networks; similar networks for control circuits were provided also—was an extension of the programme circuit provision frame in Trunk Test, North Block, Faraday Building. This frame provides a terminating and flexibility point for all programme transmission circuits set up on the trunk network. In addition a special jack field was provided in Continental Test designed for a maximum of 20 simultaneous broadcasts to the Continent. A number of screened-pair tie cables between the various Blocks was also provided.

A measure of the work involved in the provision of the B.B.C.'s circuits required for programme transmission and control may be gauged from the following table which indicates the number of circuits provided in the three Regions concerned.

	L.T.R.	H.C.R.	S.W.R.
Programme circuits	171	40	5
Control circuits	145	34	3

All the above were provided as temporary private wire circuits with the exception of those in the South-Western Region, which were dealt with on an "outside broadcast" basis. The programme circuits were set up to transmit over the frequency range of 50-5,500 c/s with freedom from noise. To cover breakdown contingencies alternative routings were effected and a limited number of "reserves" were available between the switching points.

As will be realised, there was a considerable amount of work in the field, including the provision of temporary cables, music amplifiers and switching panels, all of which was completed and handed over for test

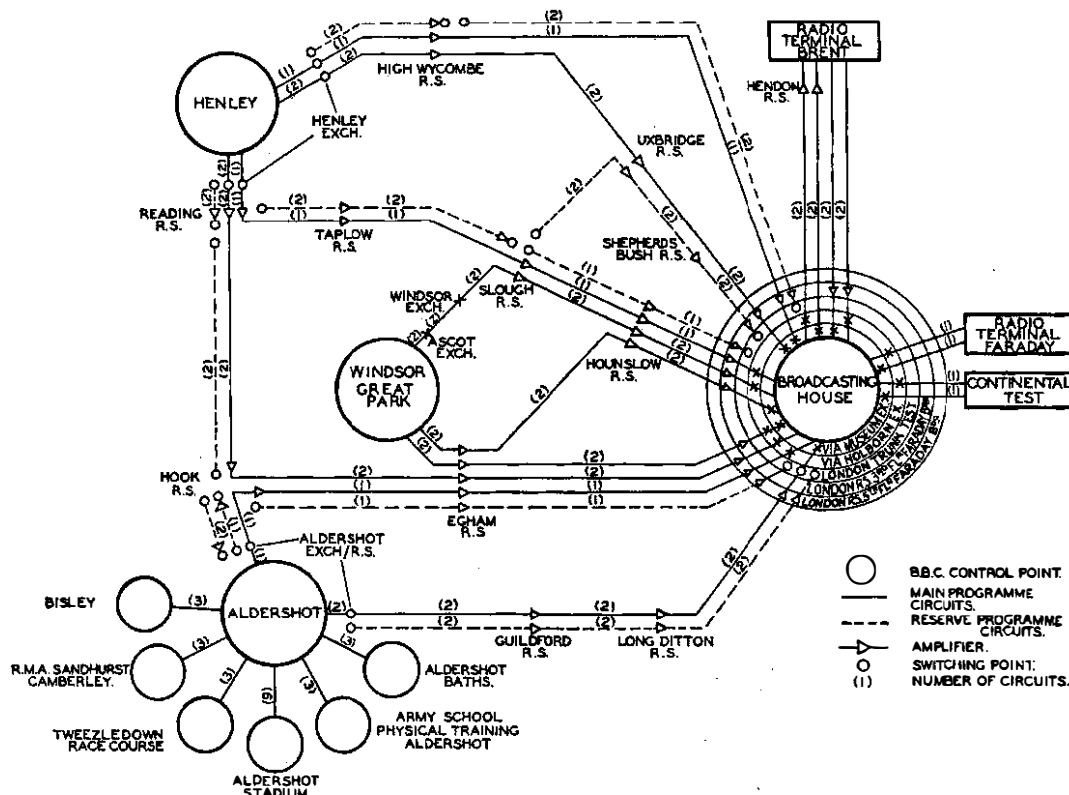

FIG. 3.—B.B.C. PROGRAMME CIRCUITS (AMPLIFIED).

and operational trials by the B.B.C. two weeks before the opening of the Olympiad.

The main control of all programme transmissions was centred on the B.B.C. control room at Broadcasting House which may rightly be described as the "hub" of the Olympiad broadcast network. A second and equally important control room was established in the Palace of Arts at Wembley for the initial control of transmissions from all arenas at Wembley. At this latter point, in addition to officers from the Inland Telecommunications and Engineering Departments dealing with the administrative aspect, an officer of the Engineering Department co-operated with B.B.C. personnel in the allocation of circuits for Overseas broadcasts which went out in many different languages. It is of interest to note that to near continental countries 511 speech broadcasts and 709 picture transmissions were handled via Continental Test; 355 additional speech broadcasts to more distant countries were routed via the radio telephony terminals and the Post Office radio stations at Rugby and Criggon, the majority of which were to the Western Hemisphere. Listeners in Britain already know of the many broadcasts in the Home and Light Programmes.

#### ARRANGEMENTS AT WEMBLEY

Although a number of field, water and indoor events were held at subsidiary venues, the communications for which involved the Post Office in a considerable amount of work, the main interest was centred in the arenas at Wembley. A brief description of some of the facilities provided follows.

##### *Arena Manager's Telephone Networks.*

The main function of the Arena Manager was the control of all events at the Stadium and his position was virtually the key point of the Games. The communications for this important post consisted, mainly, of two telephone networks:

- (a) *Administrative Network.* A 10-line multiphone switchboard was installed in the Arena Manager's office at the side of the track, with extensions to key points in the Stadium for the general co-ordination of activities in the Stadium during the Games. Over this network instructions were given during the opening ceremony, competitors were located and special announcements given for transfer to the public address system. The

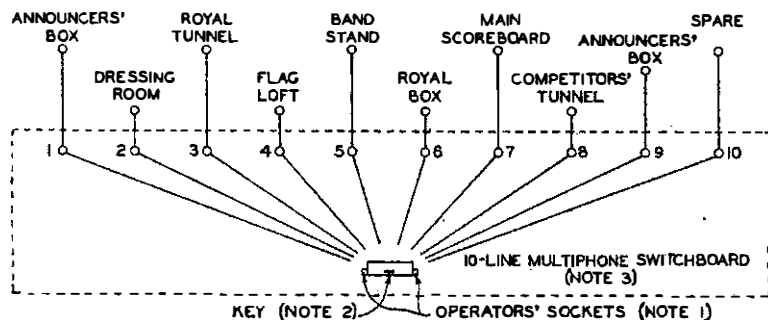

- Note 1: Two operators, each with double headgear receivers and transmitter.  
 Note 2: Key to provide complete control by one or both operators.  
 Note 3: Magneto calling to and from switchboard.

FIG. 4.—ADMINISTRATIVE TELEPHONE NETWORK.

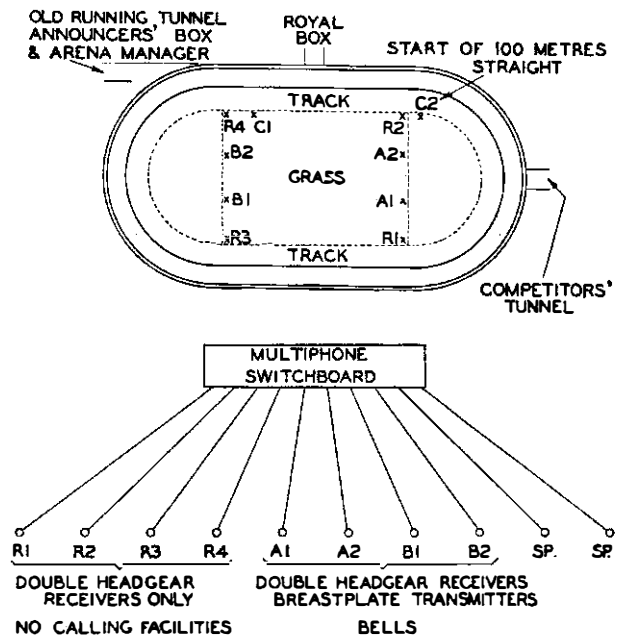

FIG. 5.—FIELD EVENTS NETWORK.

transmission of these messages to the various points was carried out by the switchboard operators on direct verbal instructions from the Arena Manager. A plan of the network with details of the equipment is shown in Fig. 4.

- (b) *Field Events Scoreboard Network.* It was necessary to provide for the audience in the Stadium, announcements of progress and results but as track and field events were often being contested simultaneously, a public address system for both might have caused confusion. It was decided, therefore, to use a public address system for the track events and a telephone network for passing all information concerning field events to an operator for visual display on the main and subsidiary scoreboards. For this purpose a second 10-line multiphone switchboard was installed in the Arena Manager's office with extension telephones at various points in the arena (see Fig. 5). These telephones were American army type field telephones fitted with breastplate transmitters, headgear receivers and nippon waterproof plugs and sockets. Some difficulty was experienced at first in working these circuits in the rain, but liberal use of adhesive tape over the cords overcame the trouble.

Recorders stationed at points marked A and B reported times, distances, etc., to the scoreboard operators who passed the information forward for visual display on the scoreboards at points R1-4, and telephones at points C1 and C2 were used for intercommunication between camera locations on the field and the photo-finish point.



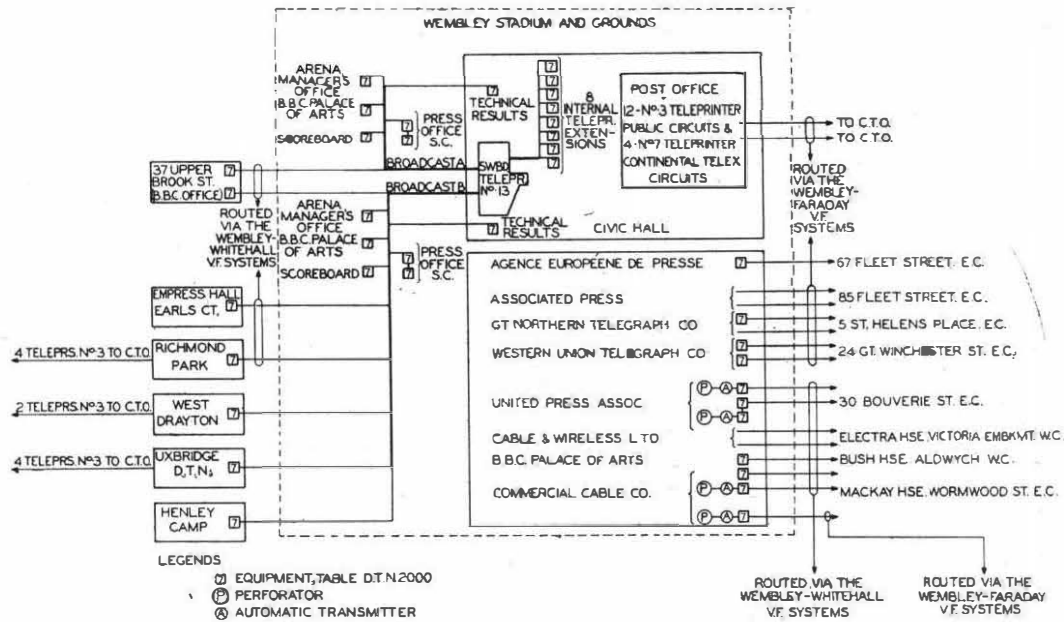

FIG. 6.—TELEPRINTER NETWORK.

*Teleprinter Network.*

This network (Fig. 6) was provided for administrative requirements of the Games, the distribution of results and public telegraph needs, and comprised two systems arranged for simultaneous broadcasts.

The facilities included a Switchboard Teleprinter No. 13 and eight local teleprinters as illustrated in Fig. 7; 12 teleprinters No. 3 for public telegraph transmissions and four teleprinters No. 7 providing an international telex service for Press representatives. The machines marked S.C. in Fig. 6 were arranged for stencil cutting and from these stencils the results broadcast were duplicated for distribution to the Press and other interested bodies. Very little difficulty was experienced with clogged typeheads on the stencil-cutting machines which were standard teleprinters No. 7. On some days the machines were working more or less continuously for about 12 hours, but it was found unnecessary to clean the typeheads more often than once every 3-4 hours.

The majority of the telegraph circuits were set up on three 12-channel V.F. systems, two to Faraday Building and one to Whitehall, operated by a mobile V.F. unit at Wembley. As a safeguard against power failure two Westat power packs in a separate lorry and a standby 6 kV generator set were held on site and cabled to the V.F. unit via change-over switches. It was not necessary, however, to use these reserves of plant.

*Telephone Service for the Press.*

This service included the provision of two 10-line switchboards, one in the Press Centre and one in the Press

Gallery, for continental and overseas bookings and for incoming foreign calls. These boards accommodated ten lines to Continental exchange and ten extensions to booths or cabinets to which calls could be switched. Booking circuits for the operators were provided on separate telephones, and language interpreters were available at each centre. When a call matured the caller or called party was announced by microphone in the Press Centre, but advised by messenger in the Press Gallery. Two minutes only was allowed for this operation, but, in spite of dense crowds at certain times, this procedure was found to be quite efficient. Fig. 8 shows the layout in the Press Centre of the booths used for trunk and local calls, the Inter-



FIG. 7.—TELEPRINTER POSITIONS FOR DISTRIBUTION OF RESULTS.



FIG. 8.—PRESS CENTRE FOR INTERNATIONAL CALLS.

national call booking table, and the suite of cabinets used by the caller on receipt of a booked continental call. In addition, some 70 private wires and 60 D.E.L.s, most of which were switchable to the Pool, were provided in the Press Gallery for various newspaper companies in order that results of events at both the Stadium and Pool could be reported.

#### *Telephone Service for the Public.*

To meet the anticipated increase in services required by the contestants and the public, 124 C.C.B.s were installed, of which 37 were kiosks No. 6 in the Stadium grounds and 87 were temporary call offices in the Stadium, the Empire Pool building, the Palace of Engineering and the Post Office. Those in the Stadium and Pool were in temporary cabinets and those in the Palace of Engineering and Post Office in temporary booths. The layout of the booths provided in the Post Office is shown in Fig. 9.

#### *Maintenance.*

The world-wide extent of the telecommunications provided for the Games will be appreciated from the foregoing description, and special maintenance arrangements were made to ensure that interruptions or breakdowns should be avoided as far as humanly possible.

Although the normal fault control procedure was adopted, it was considered advisable to introduce additional features to achieve rapid reporting and clearance of faults. The scheme included the following :—

- (a) Day-to-day inspection of apparatus and the attendance at Wembley of staff available for maintenance from 8.00 a.m to 11.30 p.m.
- (b) The preparation of plans showing details of the routing of all B.B.C.

programme and control circuits. The fault control centres were also indicated on these plans and copies were supplied to the B.B.C., who were requested to report any faults to the relevant fault control centre.

- (c) Attendance for the period of a broadcast at normally unattended repeater stations, at which programme or control circuits were amplified or switched.

In addition, to assist rapid fault location, an engineering speaker network was provided, independent of the public system.

In spite of inclement weather and the magnitude of the job, no serious faults were encountered.

#### *Conclusion.*

It is pleasing to relate that provision of plant from the planning stages to completion in the field was such that all circuit requirements were met ; there

is also evidence that the whole scheme gave every satisfaction in operation. This successful provision and operation of the telecommunications network was in no small measure due to the enthusiasm and co-operation so freely displayed by all Post Office staff concerned.

Mention should also be made of the Ministry of Works who completed the building for Corinthian exchange in advance of the scheduled date.

#### *Acknowledgments.*

The authors express their thanks to the various members of the Engineer-in-Chief's office and London Telecommunications Region who kindly provided information of assistance in the preparation of the article.

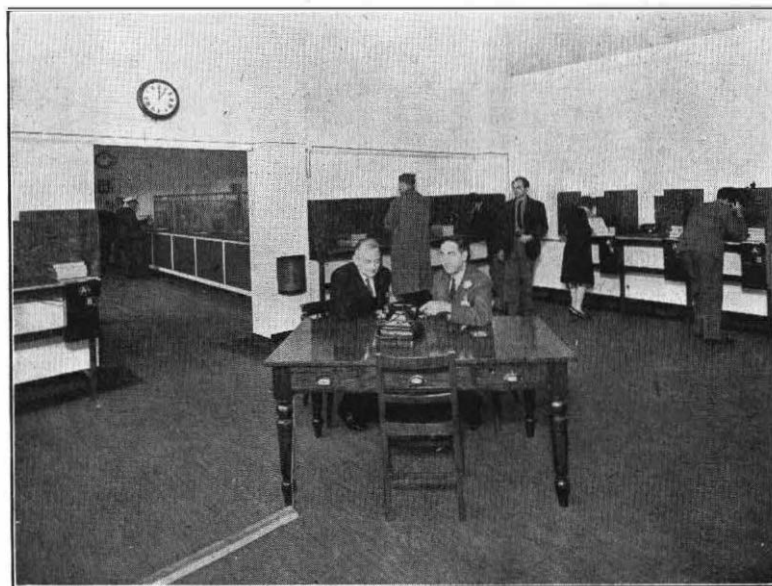

FIG. 9.—PUBLIC TELEPHONE BOOTHS IN POST OFFICE.

# Centralised Fire Control Switchboard for London Fire Brigade

W. T. WOODING, A.M.I.E.E.

U.D.C. 621.395.655.2 : 614.842

A special switchboard has been installed at the Lambeth Headquarters of the London County Council Fire Brigade giving centralised control of the 58 fire stations in the L.C.C. Area. This article describes the switchboard and facilities provided.

## Introduction.

SINCE the introduction of the "999" facility in London in 1937, the public have made full use of this service, and calls for the Fire Brigade are a very important part of the traffic received on these lines. Until April this year, the operator receiving a "Fire" call extended the caller to the fire station over an exchange line; this line, "2222", had joint access from the auto-manual board and the final selector multiple. If the line was engaged, alternative means of extension via other exchanges were available.

As the fire calls were passed to one of five Divisional Stations a considerable number of these lines were out-of-area circuits. To provide for emergency the fire telephone in the exchange was arranged to intercept the "2222" line. This arrangement continued during the war, and when preparations were being made to hand back the Fire Service to County Authorities, the London Fire Brigade approached the Regional Director with a suggestion that a centralised fire control switchboard for the L.C.C. area would be an advantage over the existing arrangement.

## General Requirements.

As a result of discussion it was agreed that the following facilities were necessary to provide for a scheme of this nature:—

- (a) A 6-position fire control switchboard; two of the positions to be placed one each side of the mobilising officer for dealing with the movement of supplementary fire appliances; the remaining four positions to be in one suite and normally used for answering fire calls on lines from exchanges and ordering out the required fire appliances.
- (b) Direct connection from auto-manual switchboards and manual exchanges to the fire control switchboard for extending calls received on the "999" service.
- (c) Private wires from the fire control board to each fire station in the L.C.C. area with a facility for switching on the station alarm bells by the fire control operator.
- (d) Special group of exchange lines to terminate on the fire control switchboard for emergency purposes.

- (e) Private wires to other Fire Authorities, Police and Ambulance services, etc.
- (f) Calling signals to be provided for each circuit at each answering position including the mobilising positions.

The scheme was quite sound, provided the Divisional Stations would accept fire calls if contact with the fire control was interrupted in any way. The Chief Officer agreed to this and pointed out that the Fire Brigade would gain many advantages with this new method of working.

## Switchboard Arrangements.

In view of the short time available for installation, the non-standard requirements of the Fire Brigade and the need for close liaison, it was agreed with the Engineer-in-Chief's office that the switchboard be designed at Regional Headquarters. Obsolete No. 9 sections were used for both the operating and dummy positions. The design of the new switchboard was agreed with the Chief Officer who kindly arranged for the wooden part of the structure to be altered by Fire Brigade staff.

*Main suite.*—The height of the new board was limited by the fact that it is necessary for the operator to see the tally board fitted to the wall at the rear of the switchboard as illustrated in Fig. 1. As a further aid in this respect, the top of the board slopes down to the rear very

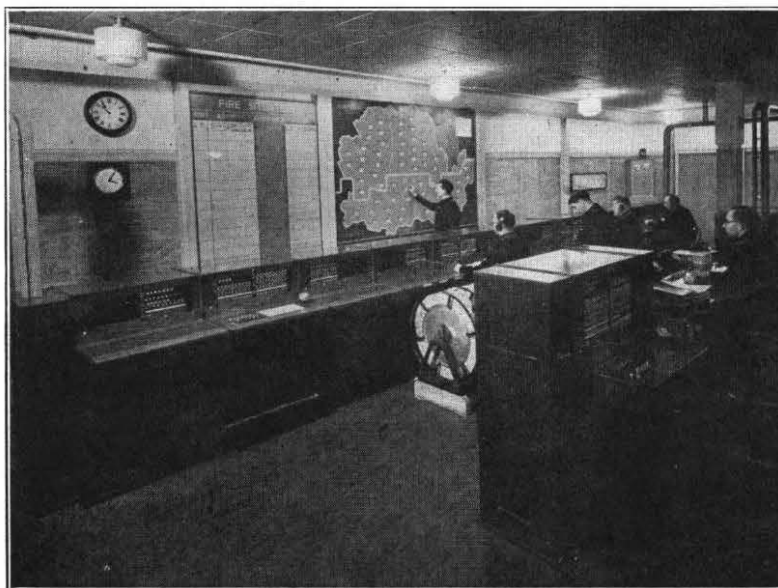

FIG. 1.—GENERAL VIEW OF SWITCHROOM.

slightly and was made to slide out to facilitate wiring operations. A 4-panel parallel multiple is provided and to ensure a minimum answering time, the Fire Brigade suggested that the layout of the face equipment should be such that any one of the six operators could answer any calling signal. This was met by providing a multiple lamp appearance in addition to the multiple jacks. This also provides against the possibility of a faulty lamp during the period between routine tests. Being an operational switchboard, the number of cord circuits has been reduced to six; this is adequate for normal purposes as it is not proposed to extend calls from one fire station to another except in special circumstances.

The cord circuits are similar to those used in No. 10 B.E.C.B. type switchboard, but with the ringing keys omitted. To meet the requirements of the miscellaneous circuits and extensions, press-buttons are associated with these lines in the multiple to apply ringing current for calling purposes.

An interesting feature of this control is a development by the London Fire Brigade of a rotary card-index system designed to give full information regarding fire appliance requirements for any street or large building in the L.C.C. area. Two rotary files—one can be seen in the centre of Fig. 1—will form a complete index with a total capacity of 24,000 cards. One rotary file is placed each side of each operator on the four main answering positions, and to accommodate these files and part of the multiple it was necessary to provide dummy positions as seen in Fig. 1.

*Mobilising Positions.*—When a fire call is received the control operator refers to the rotary file and orders out the appliances indicated. This is known as the first attendance and invariably involves two or three stations. For a serious fire it may be necessary to supplement the first attendance with additional pumps or other equipment; also, a considerable

movement of appliances may be necessary on occasion to avoid stations remaining depleted. This work is carried out from the two mobilising positions which have been built slightly higher than the main suite to accommodate the whole of the multiple in two panels as seen in Fig. 2. These two positions were provided mainly for mobilising work but in an emergency they can, of course, be used as ordinary answering positions.

#### *Outline of Circuit Operation.*

With the exception of lines from manual exchanges, the calling signal at the fire control is operated automatically when the exchange operator plugs in. Uni-directional service is provided and this ensures that they are used only for extending calls received on the "999" service.

There are 69 exchanges in the L.C.C. area but 20 of these have remote manual boards or share with other exchanges. To meet the traffic requirements, however, a total of 66 lines was provided from manual boards. A private wire is provided to each of the 58 fire stations and special attention has been given to the routing of all lines terminating at the fire control, to ensure minimum interference in the event of a cable breakdown.

Automatic signalling is also provided on the private wires to fire stations. These are both-way working and in addition to the normal speech facility, an arrangement is provided whereby it is possible for the fire control operator to ring the fire bells at the fire station. To do this, the operator presses a button immediately above the fire station jack in the multiple. This ensures a prompt answer from the fire station and enables the fire appliances to be started and manned ready for despatch. A general idea of the arrangements can be seen from the schematic diagram, Fig. 3, but a brief outline of the circuit operations may be of interest to those concerned with the design and operation of installations of this type.

A "999" call is received at the manual board on positions earmarked for this purpose, and assuming the Fire Brigade is wanted, the operator plugs into the fire control line jack. A uni-directional generator-signalling relay set is associated with this line, and when the fire control operator answers, the ringing is tripped and reverse battery conditions operate the **D** relay in the uni-directional relay set at the exchange to give the correct supervisory conditions to the "999" operator. On receipt of the call, the fire control operator ascertains the location of the fire and, with the help of the rotary index file, determines the fire station best suited to deal with the call. The operator then plugs into the jack connected to this fire station and presses the fire bell "call" button PB. (Fig. 4). The calling lamp at the fire station lights when L relay operates from earth on the B wire. The

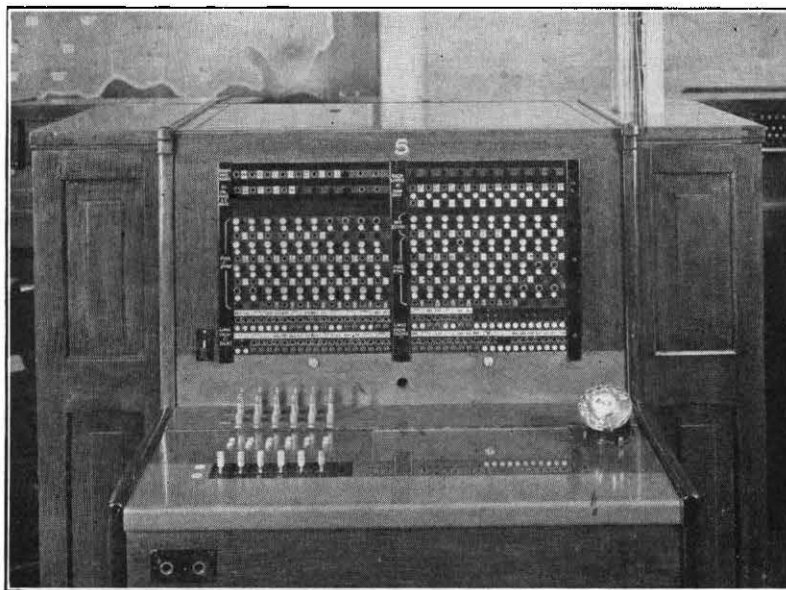

FIG. 2.—MOBILISING POSITION.

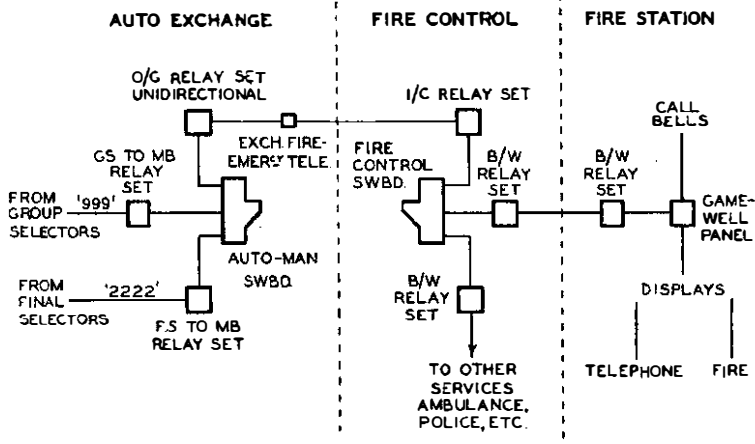

FIG. 3.—OUTLINE OF CIRCUIT ARRANGEMENTS.

press-button operates relay FC which connects the positive battery to the A wire operating FB relay at the fire station. Relays AB and FFL are then operated bringing in the fire station bells and the fire flash signal on the Gamewell panel. In view of the importance of this feature, it was necessary to guard against false operation of FB relay by providing

*Transfer Arrangements.*

The Area staff had to work at high pressure to enable the switchboard to be ready for service on 1st April, the date set by the Home Office for handing over the fire service to County Authorities. The transfer from the old to the new system was carried out on an L.F.B. area basis, the area covered by the

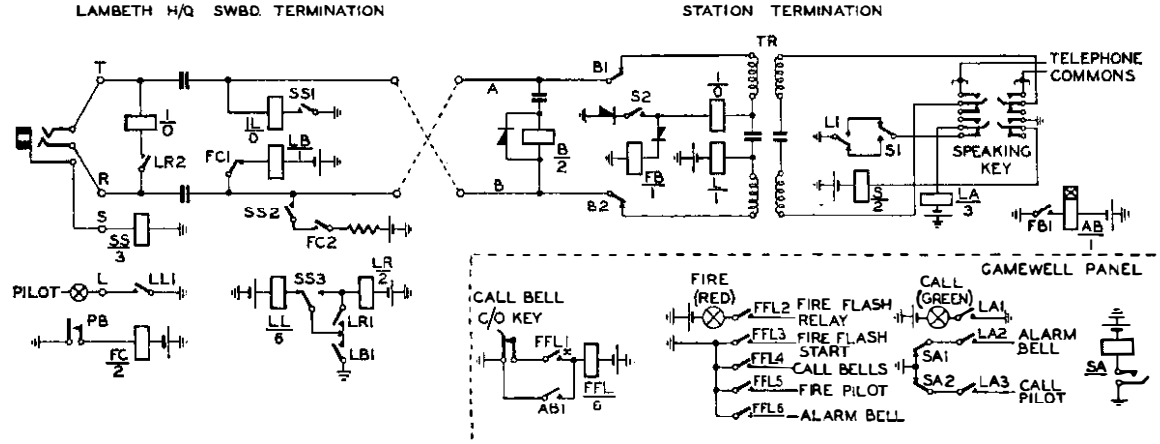

FIG. 4.—SIMPLIFIED CIRCUIT SHOWING HEADQUARTERS AND STATION TERMINATIONS.

relay B to prevent false operation due to ringing current on the line, and in addition relay AB (slow-to-operate) is provided to guard against operation of the fire flash relay FFL due to line surges. These precautionary measures have been found to be very effective in preventing false rings on the fire station bells.

It is necessary to have both-way communication on this line, and when the speaking key is thrown on the Gamewell panel, automatic signalling is provided to call the fire control. To provide the standard supervisory conditions, an earth is applied to the A wire by S2 contact and a rectifier is connected in series with the earth to offer a high resistance path to the positive battery fire bell "call" signal should this be applied whilst the speaking key at the fire station is thrown.

The "2222" exchanges lines to the Divisional fire stations have been recovered, but in view of the possibility of fire calls still being received on

these lines, arrangements have been made to reterminate them for the time being on the auto-manual board. Calls received on these lines are extended to the fire control over the direct circuit and to ensure prompt attention by the exchange operator, the calling signals are associated with the "999" exchange alarm.

The exchange fire telephone arrangements have been revised to take advantage of the new scheme. Previously this telephone intercepted the "2222" exchange lines to the fire station, but it is now designed to intercept the direct line from the manual board to the fire control. At those exchanges with the manual board remote, the fire telephone intercepts the 3rd choice "999" circuit from that exchange to the manual board.

Manchester Square Divisional Station being satisfactorily transferred on 1st April, with 25 lines to exchanges, 15 lines to fire stations and tie lines to police, ambulance and other fire services. Within a few weeks the whole of the L.C.C. Area was centralised on the fire control switchboard.

*Conclusion.*

The Fire Brigade report that so far the Control has met every demand that was envisaged when design details were decided.

The ready for service date for this installation could not have been met without the full co-operation of the Area staffs; also very valuable assistance was given by the London Fire Brigade, both at the Lambeth Headquarters in modifying the switchboards to make them suitable for this purpose, and at the fire stations to provide for the termination of the private wire from the fire control switchboard.

# A Highly-Selective Transmission Measuring Equipment for 12- and 24-Channel Carrier Systems

D. G. TUCKER, D.Sc., Ph.D.,  
and J. GARLICK, B.Sc.

U.D.C. 621.317.34 : 621.395.44

**A new method of making transmission measurements, using a test tone modulated by a very low frequency (e.g. 33 c/s) and direct demodulation of the test signal in the receiver with filtration following the demodulation enables the transmission efficiency of carrier systems to be measured without removing traffic. Experimental equipment employing this method is described.**

## *Introduction.*

IT has been thought in recent years that an effort should be made to measure the transmission efficiency of a carrier system without removing it, or even a channel, from service. The use of high-level tones which can be detected above traffic signals on a voltmeter connected across the line has given a temporary means of doing this, but the method cannot be regarded as suitable for permanent adoption because of its low accuracy and the severe loading of common amplifiers which the high-level tone produces. Consequently, an investigation has been made of the possibility of making the measurements by the selective reception of normal-level test tones transmitted in the small frequency gaps between speech channels.

The specification for the performance of equipment to make such selective measurements includes a requirement for an accuracy of  $\pm 0.25$  db. at the sending and receiving ends. When it is realised that this figure must include the effect of interference from the traffic circuits, and from channel carrier leak which comes in the narrow frequency bands available for measurement, and moreover that the whole equipment must be preset, without fine tuning, it can be seen that this accuracy of  $\pm 0.25$  db. is a very severe requirement. As a basis of design it was decided to aim at a maximum error of 0.1 db. in any one of the factors which are liable to produce error, it being assumed that the probability of the overall error at one end exceeding 0.25 db. is then small.

To achieve the required performance, some new principles have been introduced, the two main ones being (1) the use of a modulated test signal to overcome the effect of channel carrier leak, and (2) direct demodulation of the test tone by means of a local oscillator synchronised to it. It is hoped that measuring equipment working on this basis will eventually be designed for use on coaxial systems up to a frequency of about 4 Mc/s, but the equipment to be described in this article is designed for use on 12- and 24-channel systems, with a choice of two test frequencies, 36 and 84 kc/s. The effective bandwidth of the receiver is about 20 c/s, and the accuracy is thought to be better than  $\pm 0.25$  db. on a short-term basis. The long-term accuracy should also be as good as this, even without regular checks of calibration, but only experience of the operation of the equipment in service can give confirmation.

The equipment to be described is a laboratory production only, and if it is produced in quantity for use in repeater stations, it may have a rather different

appearance and mechanical design. An outline description is published now because of the interest of the new methods adopted.

## *The General Principle of Measurement.*

The general principle of the system has already been described elsewhere<sup>1</sup>; it is to use a test tone of frequency equal to one of the channel carriers—this choice being made for convenience since the carrier frequencies are already available in terminal repeater stations, and in spite of the fact that an unsymmetrical layout of the frequency gap between channels results—and to modulate this to a depth of about 30 per cent. by a low frequency, ultimately fixed at 33 c/s. Since the receiving equipment is arranged to measure only the sidebands of this modulation, no direct interference from channel carrier leak can result.

The receiver consists of a modulator of switching type operated by a local oscillator, synchronised to the test tone. The input of the modulator is connected (via an amplifier) across the carrier system at the point where the level is to be measured. The test-tone carrier is thus demodulated to a frequency of zero, i.e. to D.C., but the sidebands accompanying the test tone are demodulated to 33 c/s. The modulator is followed by a band-pass filter passing the 10 c/s band from 28 c/s to 38 c/s. It is evident that only the sidebands of the test tone produce signals on demodulation which can pass this filter; all products from the speech circuits are rejected (except for an effect noted below). Thus, the effective bandwidth of the receiver is 20 c/s, made up of a 10 c/s band on each side of the test tone frequency. The 33 c/s output from the filter is measured by a suitable valve voltmeter, and the reading gives the transmission measurement of the carrier system.

This system of reception is based on exactly the same principle as the Synchrodyne radio receiver<sup>2</sup> which is by now fairly well known.

In the original publication<sup>1</sup> of the proposed method of measurement it was pointed out that since the phase angle between the test tone and the local oscillator could vary between  $-90^\circ$  and  $+90^\circ$  over the synchronising range of the oscillator, and any change in this phase angle causes a variation in the level of the 33 c/s output, it was necessary to compensate for the phase angle by an automatic circuit of some sort, and a suitable method was described. It has since been found much better not to compensate for the phase angle, but instead to control it to an almost constant value of zero by an automatic control circuit of the servo type; the principle has

been published<sup>3</sup> in connection with the Synchrodyne radio receiver.

The choice of 33 c/s for the test-tone modulation was dictated by interference from speech signals on the adjacent traffic channels. Speech signals contain envelope frequencies<sup>4</sup> from zero up to 20-30 c/s which can be demodulated by the measuring receiver in the same way as the test tone modulation, if the speech itself is close enough in frequency to the test tone to get into the output of the synchronised oscillator. Thus the modulation should be of frequency above, say, 30 c/s. But speech also contains fundamental frequencies down to perhaps 80 c/s, and there is generally some 50 c/s interference from the mains; 33 c/s seemed a good compromise, and has been found satisfactory in practice. The originally proposed 20 c/s modulation was found unsatisfactory.

#### *Sending-End Equipment.*

The sending-end equipment comprises a special modulator for producing the envelope-modulated test signal, a 33 c/s oscillator, and equipment to enable the various other frequencies required to be obtained from the carrier generating equipment of Carrier Systems Nos. 5, 6 or 7. The test tone frequencies required are 36 and 84 kc/s (i.e. one tone in the middle of each of the two working group frequency bands) and the special modulator generates the test signal always at 84 kc/s, the 36 kc/s signal being obtained from this by modulation in the usual way with either 48 or 120 kc/s. Fig. 1 (a) shows a block schematic diagram of the equipment.

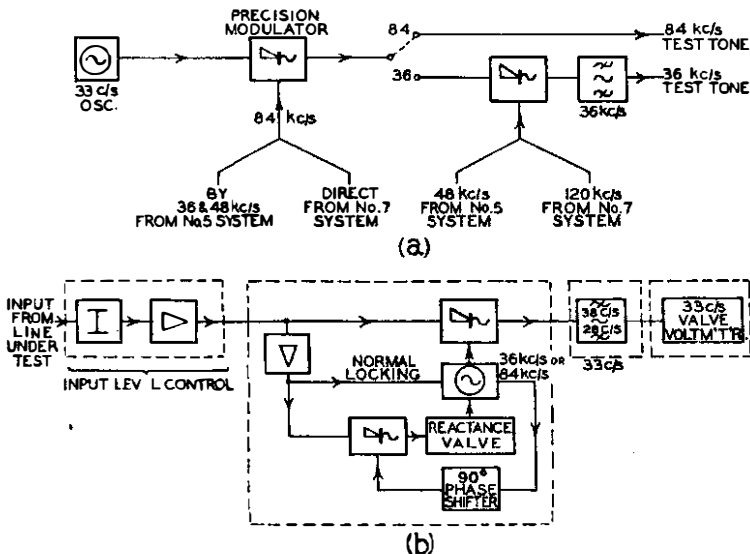

FIG. 1.—BLOCK SCHEMATIC DIAGRAM OF SET :

(a) SENDING END EQUIPMENT. (b) RECEIVING END EQUIPMENT.

The only part of the sending-end equipment which involves any circuits which are not standard types is the special modulator. This has requirements which are not all met by a normal multi-electrode valve modulator, which is probably the standard type for envelope modulation; they are :

- (1) The sideband level (which forms the basis of the transmission measurement) must be measurable to 0.1 db. and the depth of modulation

should be reasonably constant—the level of the carrier is not, of course, important in the same sense as that of the sidebands.

- (2) The modulation should be sinusoidal (i.e. the modulator should be linear) up to, say, 35 per cent. depth.
- (3) The modulation should be a fairly pure amplitude-modulation, i.e., the phase angle of the carrier should be correct to within about 5° (this limit will be explained in the next section).

The method adopted is as follows:—The basic principle is to generate a suppressed-carrier modulated signal by applying the 33 c/s to the input terminals of a balanced rectifier modulator, switched by the 84 kc/s carrier. The output of this modulator, after it has been adjusted for minimum carrier leak, should contain only the two sidebands of the carrier frequency and of each odd harmonic of it. The carrier frequency is then injected into the output to give the required depth of modulation, and the sidebands of the carrier harmonics are filtered out. It is obvious that this arrangement meets requirement (1), since the carrier or the sidebands can be removed without affecting the level of the signal which remains. It also meets requirement (2), since the input level can be reduced until the modulation is linear, and then the carrier reduced to maintain the required depth of modulation.

The main practical difficulty has been in meeting requirement (3). It is very difficult to measure the phase of a carrier relative to its sidebands, and certainly an inspection of the modulated waveform

helps very little. When transformers are used in the modulator circuit, the phase relationships are not accurately predictable, and a variable phase-shifter has to be fitted, and a method devised of determining when the phase of the carrier is correct. One such method consists of increasing the level of the 33 c/s applied to the modulator by an amount sufficient to bring the depth of modulation to very nearly 100 per cent.; the troughs of the modulated envelope then leave a very small amplitude of the wave, and this is a minimum when the phase of the carrier is correct. The accuracy of adjustment of phase then depends on the closeness to 100 per cent. of the depth of modulation, since small changes in amplitude are most easily detectable when the amplitude is itself small.

Recently some balanced rectifier modulator circuits have been developed which use no transformers, and these enable the envelope-modulating unit to be made with only resistance-capacitance couplings. Such couplings can readily be made to have effectively zero phase-angle, and the need for adjustment is eliminated. The method described above is then used merely as an initial acceptance test.

#### *Receiving-End Equipment.*

As Fig. 1 (b) shows, the main signal path at the receiving end consists of a demodulator which extracts

the modulation from the test-tone, a 33 c/s band-pass filter, and finally a valve-voltmeter which indicates directly the sideband level. In the final design, the valve voltmeter will be calibrated over a range of 10 db., extensions of the range of the equipment being provided by suitable attenuator pads and amplifiers connected between the input to the demodulator and the line under test.

The switching voltage for the signal demodulator is provided by a local oscillator having a natural frequency approximately that of the test-tone, and synchronised to it by injecting into the oscillator a fraction of all the line signals. The level of this injected tone is important<sup>3</sup>, since too high a level of synchronising signal will produce unwanted line frequencies in the oscillator output, causing interference to the final reading. On the other hand, too low a level of injected signal may prevent synchronisation to the test tone being effected if the natural frequency of the local oscillator should have drifted due, for example, to component ageing or temperature changes, some way from its nominal value. The level of synchronising signal is maintained constant at its required value by feeding from the line to the local oscillator through a constant voltage amplifier which maintains a constant output over a suitable range of input levels.

The output of 33 c/s from the demodulator is dependent on the phase angle<sup>†</sup> between the carrier of the test tone and the switching voltage applied to the demodulator. This phase angle is dependent on the phase-shift,  $\theta$ , of the synchronised oscillator, which can be kept constant either by the use of a high level of synchronising signal, or by ensuring that the oscillator natural frequency is maintained almost identical with the test tone frequency. The former is not possible because of interference considerations, and a control circuit<sup>3</sup> is therefore associated with the oscillator so that changes in the oscillator phase angle,  $\theta$ , indicating departures in its natural frequency from the test tone frequency, produce a corresponding D.C. voltage which is applied to the grid of a reactance valve connected across the oscillator tuned circuit. The sense of this control voltage is such that changes in the oscillator natural frequency are reduced by a factor equal to the gain of this phase-control loop, which operates as a type of servomechanism. This loop gain can conveniently be made of the order of several hundred.

The D.C. control voltage dependent on the phase angle between the synchronised oscillator input and output signals is produced by modulating the two voltages together. The main outputs of this modulator are the sum and difference of the two applied frequencies, which are in this case equal; the sum is a high frequency which can readily be filtered out,

<sup>†</sup> It can easily be shown that the wanted output is proportional to the cosine of this phase angle. Thus, if the normal operating condition is with this cosine equal to unity, an error of 0.1 db. will be introduced by a change of angle of about 8°.

while the difference is a D.C. voltage dependent in magnitude on the phase angle between the applied voltages. To ensure that this D.C. voltage has a sense dependent on the sign of the difference between the synchronising and natural oscillator frequencies, a 90° phase-shift is introduced into the path of one of the signals to the control modulator, so that its D.C. output is proportional to an odd function (in this case the sine) of  $\theta$ .

The reactance valve to which the D.C. is applied is of the type commonly used in F.M. transmission. A simple C-R phase-shifting network connected between anode and grid provides a largely reactive output impedance with a negative angle, and of magnitude dependent on the valve mutual conductance, which in turn depends on the grid voltage. This output impedance is connected across the oscillator tuned circuit, so that control of its natural frequency is obtained by variation of the reactance valve grid voltage.

It can be seen that one of the effects of the frequency control circuit will be to increase greatly the pull-out range of the synchronised oscillator. Provided the time-constant of the D.C. path to the reactance valve is high, the pull-in range is substantially that of the simply-synchronised oscillator, which can be made as small as the stability of the oscillator will permit, by a suitable choice of locking level. Thus, the possibility of pull-in to an unwanted frequency is negligible, while not only will the oscillator, once synchronised, remain in lock, but its natural frequency will remain close to that of test tone, thereby keeping  $\theta$  approximately zero. In the event of a circuit fault causing  $\theta$  to depart appreciably from 0°, a misleading reading would be obtained on the final meter. Facilities for monitoring the phase angle of the synchronised oscillator to simplify detection of such errors can easily be provided by a D.C. voltmeter in the reactance valve grid circuit, and limits for the D.C. voltage marked, corresponding to any given error on the final reading. A centre-zero voltmeter for indicating this voltage can be seen in the photograph of the main receiving panel (Fig. 2).

The 33 c/s band-pass filter, with a bandwidth of

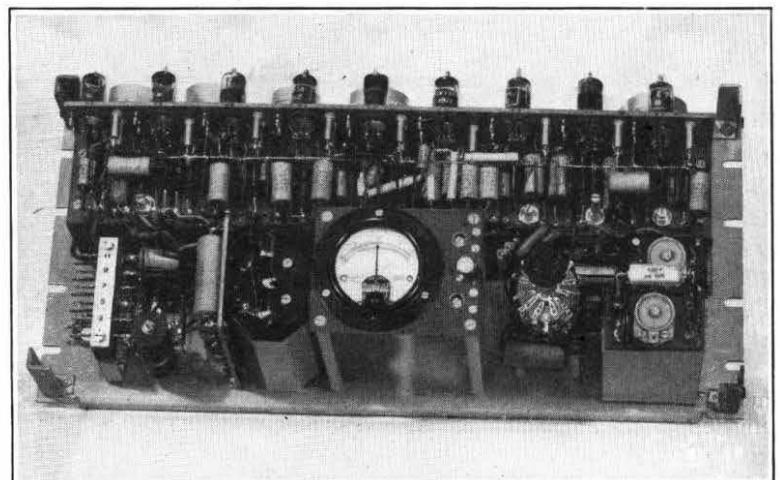

FIG. 2.—MAIN RECEIVING-END (DEMODULATING) UNIT.



about 10 c/s is fitted after the signal demodulator to prevent speech frequencies which are demodulated in the signal modulator from affecting the measuring set reading. Some tuning is provided in the valve-voltmeter and tests so far suggest that a constant-k single section will be adequate for the filter.

The valve-voltmeter (Fig. 3) consists of a two-stage negative feedback amplifier with a full-wave diode

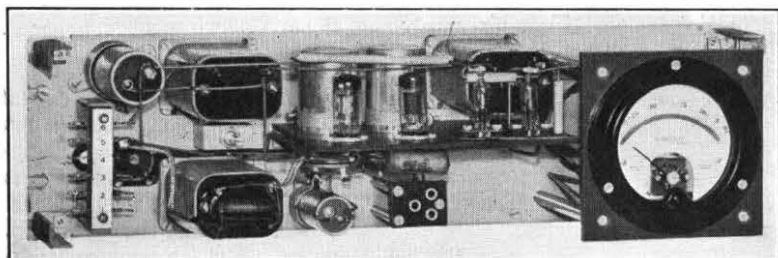

FIG. 3.—VALVE VOLTMETER.

rectifier bridge connected in the anode circuit of the last valve. The rectifier circuit operates a D.C. milliammeter calibrated directly in decibels.

#### Calibration.

It can be seen that the nature of the receiving-end equipment does not readily permit an absolute calibration against a single frequency which has been checked by comparison with a standard such as a thermocouple. However, as shown previously, the method of generation of the test tone enables the two sidebands to be obtained alone without the carrier. The absolute level of the generated sidebands can thus be measured directly, and an absolute calibration of the receiving end carried out by the application of a modulated test tone for which the sideband level is accurately known. The receiving equipment response with a double sideband test-tone will be 6 db. higher than with one sideband, and a correction must

therefore be made if the meter used for the sideband measurement is other than a peak-reading instrument. If a R.M.S. meter is used for the absolute measurement, for instance, a 3 db. correction will be necessary.

#### Performance.

Models of the selective measuring equipment, working at 36 and 84 kc/s have been constructed and tested under laboratory and repeater station conditions. These tests have confirmed that the principle adopted is capable of meeting the required specification in respect of accuracy of reading and freedom from interference due to traffic on the system under test. The main receiving unit, without preliminary amplifiers and attenuators, if calibrated at one level, is accurate to  $\pm 0.1$  db. over a 20 db. range, while interference from traffic signals does not in general exceed  $\pm 0.1$  db. Very occasionally,

peaks of interference may exceed this, but even these do not prevent a measurement being obtained to within 0.1 db.

The long-term stability of the equipment has not yet been fully determined, but it is anticipated that no recheck of calibration will be necessary over periods of several months.

#### References

- <sup>1</sup> Tucker, D. G., "Highly-Selective Transmission-Measuring Equipment for Communication Circuits," *J.I.E.E.*, Vol. 94, Part III, 1947, pp. 211-216.
- <sup>2</sup> Tucker, D. G., "The Synchrodyne," *Electronic Engineering*, Vol. 19, 1947, pp. 75-6, 241-5, 276-7.
- <sup>3</sup> Garlick, J., "The Synchrodyne: Control of the Phase Angle between the Output and Injected Signal of the Synchronised Oscillator," *Electronic Engineering*, Vol. 20, 1948, pp. 49-50.
- <sup>4</sup> Dudley, H., "The Carrier Nature of Speech," *B.S.T.J.*, Vol. 19, 1940, p. 495-515.
- <sup>5</sup> Tucker, D. G., "Nonlinear Regenerative Circuits," *Wireless Engineer*, Vol. 24, 1947, pp. 178-184.

## Book Review

"Radio Laboratory Handbook." 4th Edition. M. G. Scroggie, B.Sc., M.I.E.E., 430 pp., 215 ill. Iliffe & Sons, Ltd. 12s. 6d.

When a book reaches its fourth edition in ten years as this has done there can be little doubt about its success; at the same time it is felt that the success is in a direction slightly different from that suggested by the title. The book begins by considering how one should set about establishing a small radio laboratory and goes on to describe the apparatus with which it might be equipped and the methods that might be adopted for measuring various quantities. The general treatment, which is discursive and largely qualitative, is excellent for the progressive amateur with some money to spend, and for the student, but the book is much more descriptive and contains less scientific and technical data than might be expected from its title. The style is informal and much sound advice and many useful warnings are tucked away in various parts of the book; in particular, the reviewer likes the emphasis put on the need for

caution and healthy scepticism in making measurements and interpreting the results of experiments.

The book contains a number of misprints and one or two obscure abbreviations. For example, one may not disapprove of "Z.F. voltage" once one knows that it replaces the hybrid expression "D.C. voltage," but how is one to guess that "Z.F." stands for "Zero Frequency"?; it also needs some intuition to know that "A.A.C." stands for "Automatic Amplitude Control." It would appear from p. 122 that the author is uncertain why, when two smoothing condensers are connected in series across a source of higher voltage than each can withstand separately, the condensers are separately shunted by leaks of the same resistance value. It is, of course, to make sure that the condenser having the higher insulation resistance is not subject to the greater stress. In spite of these and one or two other minor blemishes the book can be recommended unreservedly to those beginning careers in radio laboratories and to students in technical colleges.

H. S.

# Notes and Comments

## Recent Awards

The Board of Editors has learnt with great pleasure of the honour recently conferred upon the following member of the Engineering Department :—

Liverpool Telephone Area .. Vaughan, G. W. Technician Private, R.A.M.C. British Empire Medal

## Birthday Honours

The Board of Editors offers sincere congratulations to the following members of the engineering staff honoured by H.M. the King in the Birthday Honours List.

Blackburn Telephone Area	.. Shaw, H.	.. Area Engineer	.. ..	Member of the Order of the British Empire
Engineering Department	.. Legg, Capt. J.	Assistant Engineer-in-Chief	..	Companion of the Imperial Service Order
Gloucester Telephone Area	.. Alder, S. F.	.. Skilled Workman, Class I	..	British Empire Medal
H.M.T.S. Monarch	.. Brennan, E. T.	Cable Foreman	..	British Empire Medal
London Telecomms. Region	.. Clover, H. E. T.	Skilled Workman, Class I	..	British Empire Medal
London Telecomms. Region	.. Sellar, W. G., M.M.	Inspector	.. ..	British Empire Medal
Sheffield Telephone Area	.. Proctor, G. A.	Technician	.. ..	British Empire Medal

## Commendation by H.M. The King

The Board of Editors has learnt with pleasure that Mr. G. Cristie, S.W. II B, of Taunton, has been commended by H.M. the King for brave conduct during the severe storms early in 1947.

## Post Office Telecommunications Journal

We understand that the first number of this new official quarterly (32 pages and cover) will appear early in November, and we wish for it all success. The *Post Office Telecommunications Journal* will deal in the main with non-engineering topics which have a bearing on the administration and operation of telecommunications, but it will no doubt have an interest to many readers on the engineering side.

The new journal is to be published in November, February, May and August at 1s. per issue and copies may be ordered through the local sales organiser.

## G. F. O'dell, C.B.E., B.Sc., M.I.E.E.

Most readers will be aware that Mr. O'dell, formerly an Assistant Engineer-in-Chief and now Director of Contracts, spent many years in the Engineering Department before transfer to the Contracts Department.

It is with pleasure, therefore, that we note his appointment as a Commander of the Order of the British Empire announced in the Birthday Honours List.

## Book Review

"Electronics." F. G. Spreadbury, A.M.Inst.B.E.  
London. Sir Isaac Pitman & Sons, Ltd. 698 pp.  
398 ill. 55s.

Electronics, as the author indicates in his preface, now covers a very wide field, and it is difficult for one man to do justice to all the principal applications. Mr. Spreadbury has concentrated on what may be termed pure electronics in the first ten chapters, or nearly half the book. This forms an excellent textbook for the student of electron physics or the telecommunication engineer who desires to know more about the fundamentals of electronic theory.

The approach to the subject is, in general, mathematical, and the first chapter covers electrons and the fine structure of matter, the kinetic, quantum and atomic theories and the atomic structure. Following chapters deal with the electron and gaseous electrical conduction, electrons in metals, insulators and semi-conductors, X-rays, electron optics, luminescence and high vacuum diodes, triodes and multi-electrode valves.

The second half of the book deals with the application of electronic devices; it is not up to the standard of the first part. Telecommunication applications are described

in two chapters of only 60 pages and are treated entirely mathematically. No practical design of an amplifier or oscillator is described and no mention is made of the limitation in amplification imposed by the random fluctuations of the inter-electrode electron stream. The H.F. requirements of a valve, either as an amplifier or an oscillator, are neglected. The telecommunication engineer will find these chapters of little use as a guide to the design and development of his equipment; and the bibliography is very meagre.

It is apparent that the author is more familiar with lighting and power applications of electronic devices than with high frequency and telecommunication applications. The chapters on electronic rectifiers, grid-controlled rectifiers, inverters and frequency changers cover these power applications in considerable detail. Electronic measuring instruments are also described with power applications in mind.

If the first part of this book were published separately and at a reduced price, it could be recommended to the telecommunication engineer; if he buys the present book it will be largely for the first part and the price paid will be somewhat high.

L. E. R.

# Headquarters Notes

## Equipment and Accommodation

### MOBILE 24-CIRCUIT CARRIER TELEPHONE REPEATER STATIONS.

The programme of the conversion of selected carrier cable routes from 12-circuit to 24-circuit operation has been delayed due to the restrictions affecting the provision of new intermediate repeater stations. Under present circumstances, it may well happen that conversion of a route may be held up for many months by one or two such buildings. Arrangements have accordingly been made for the construction of two mobile stations to provide all the essential facilities to enable the conversion to proceed. Each station comprises four trailer vehicles, two to house the repeater apparatus, one to house the centralised power plant, and one to provide welfare accommodation for the maintenance officer. The mobile station operates from the public supply mains with short-term battery standby.

The construction of the mobile stations is due to be completed shortly, and they may be employed initially on the Oxford-Birmingham route at Enstone and Henley-in-Arden.

### POWER SUPPLY FOR AMPLIFIER STATIONS.

Consideration has been given to the integration of the "A" supply of amplifier installations with the 50-volt telephone exchange power plant where these are housed in the same building, with consequent part saving in cost both of the normal "A" supply power plant and the accommodation necessary to house it. Suitable modifications can readily be effected to standard amplifier equipment to make it suitable for efficient operation on a 50-volt basis.

Trial installations are being arranged in the L.T.R. at Eltham, Tideway and Uplands. Depending on the success of these installations the question of the adoption of the scheme as a standard method of operation in telephone exchanges will be considered.

### P.O. ENGINEERING EXHIBIT IN PARIS.

The most recent exhibition, in which the Post Office participated, opened up new territory for the Engineer-in-Chief's Publicity Group in that, for the first time, the G.P.O. sent an engineering exhibit to an overseas exhibition.

During the run of Radiolympia, 1947, the Director of the Palais de la Découverte of the University of Paris saw the Post Office stand, and was so impressed as to ask for the section dealing with the British system of automatic telephony to be sent over to France for an exhibition which he was organising in Paris to commemorate the lives and work of Sir Humphry Davy and Michael Faraday.

The exhibit (see Fig. 1) is a full-size model of parts of a 10,000-line automatic exchange consisting of meter rack, unselector, 1st and 2nd group, and final selector racks, and two working telephones. The racks are of plywood with photographic treatment, but have several working switches of each type and are arranged so as to represent an automatic apparatus

room, additional depth and perspective being obtained by a large photographic back scene showing a general view.

Visitors were able to dial numbers for themselves, watch the switches in operation, note the various tones and the stages at which they are received, see the meters working, and speak over the lines thus selected.

As similar apparatus had been previously exhibited by the G.P.O. the exhibit itself provided no new departure in display technique.

Transporting the bulky and fragile equipment to Paris with the risk of delay and damage attendant upon repeated loading and unloading for Customs examination presented a problem which was effectively solved by the Motor Transport Branch undertaking the unusual task of loading up in Liverpool and carrying right through to Paris without intermediate unloading.

For this purpose one of the 2-ton Albion vehicles of the road haulage fleet was selected. This van before being completely reconditioned was an R.A.F. ambulance and it is of interest to note that its first operation in civilian guise was to revisit France on yet another mission of good will between the Allies.

Arrangements were made with H.M. Customs and Excise, and with M. le Directeur Générale des Douanes with a view to facilitating the van's passage through Customs.

The Albion, with its exhibition load, crossed from Dover to Dunkirk on the train ferry ship *Shepperton*, and their safe arrival at the Palais de la Découverte in Paris completed another interesting and unusual transport job.

The automatic telephone system of Paris and its environs is Western Electric Rotary and few French telecommunication engineers are familiar with the Strowger system or have worked on 2000-type equipment. It was therefore necessary for an officer of the Publicity Group to supervise the installation of the display and train the French engineers to maintain and demonstrate the British Post Office exhibit.

Apart from the novelty of negotiating with architects, builders, carpenters, electricians, painters, signwriters and journalists in a foreign language, the

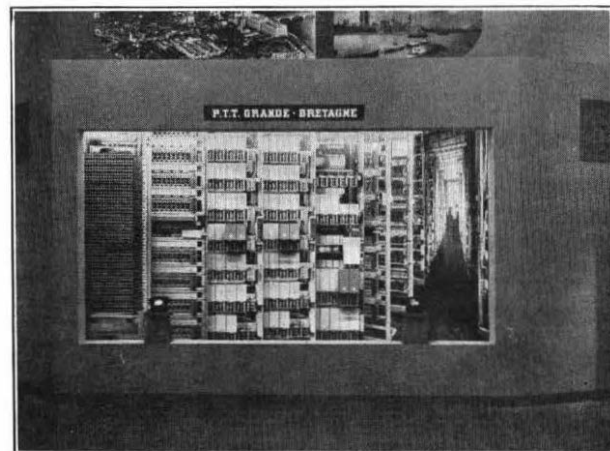

FIG. 1.

installation presented no unusual difficulty. The Exhibition was opened by Monsieur Depreux, Minister of Education, in the presence of a gathering of distinguished scientists.

### **Training**

#### **CORRESPONDENCE COURSES IN TELECOMMUNICATIONS ENGINEERING.**

Three of the fourth year subjects in Telecommunications Engineering, namely, Mathematics for Telecommunications IV, Telecommunications (Principles) IV and Telephone Exchange Systems III, are being prepared for inclusion in the correspondence courses for the 1948/9 session. Owing to staff and production difficulties it has not been found possible to include the outstanding subjects of the fourth year, and those of the fifth year, in the above session. These are, however, expected to be available within the next two or three years.

Every effort is being made to ensure that no delay will occur in the issue of lesson papers, but no definite guarantee can be given at this stage in respect of the subjects mentioned above. An improvement in both rate of issue and freedom from typographical and other errors is expected during 1948 in all correspondence course lessons.

### **Research and Radio Development**

#### **"OPEN DAY" AT THE RESEARCH STATION.**

For the first time for many years an Open Day was held at the Research Station at Dollis Hill on 1st July, 1948, between the hours 2 and 7 p.m. More than 400 visitors from universities, Government research establishments, industry, the Post Office and other bodies with telecommunications interests attended. Each visitor was presented with a little booklet which served as a guide and contained a brief description of the Station and of each of the staged exhibits.

Exhibits and demonstrations were arranged in the various laboratories and workshops of the Research and Radio Development Branches to illustrate the range of problems investigated and some of the special experimental techniques employed. Demonstrators were at hand to discuss any item in as much detail as visitors wished.

On the following day the event was repeated for the benefit of the staff and their friends and of colleagues in other branches. The rare opportunity was thus given to each member of the staff to see something of the work of all the others. Demonstrators were, of course, not wholly free to leave their exhibits, but they were available in sufficient numbers to give as much personal attention as possible to visitors on the first day, and to relieve each other for touring the Station on the second day.

There is not space here to give any account of the items exhibited and demonstrated. Mention of some has been made in the technical press and the occasion has been marked by the appearance of an article about the Research Station and its work in *Nature* (Vol. 162, p. 51, 10th July, 1948).

### **Telephones**

#### **EXCHANGE MAINTENANCE—PIECE-PART REPLACEMENTS.**

During the past year or so an extensive programme of overhaul of exchanges has been undertaken in an attempt to overtake the arrears of maintenance which, due to labour and stores shortages, were allowed to accumulate during the war years. This has resulted in demands for hundreds of thousands of relay and mechanically operated spring-sets and other piece-parts, which has necessitated expansion in manpower and/or accommodation in the London and Birmingham depots.

The reconditioning and repair of non-standard piece-parts by the Factories Department has effected considerable economy as well as relieving the manufacturers of the necessity of making new parts. The magnitude of this undertaking may be gauged from the fact that 40,000 relay spring-sets are being re-contacted and several hundred relay coils rewound per month.

It is estimated that the reconditioning and repair work undertaken during the year ending 31st March, 1948, resulted in a saving to the Post Office of approximately £10,000.

#### **"ENG" SERVICE.**

An economic study has been made regarding the application of a "Filtered ENG" scheme to maintenance controls. The scheme provides for complaints being first dealt with by a monitor who decides whether or not engineering attention is required, thus ensuring that engineering staff handle genuine complaints only and obviating the need for subscribers to distinguish between various types of faults. Arrangements are in hand for a field trial of the scheme at one or two suitable maintenance controls.

#### **AUTOMATIC EXCHANGES FOR SMALL RURAL COMMUNITIES.**

With a view to providing economically for telephone service in small rural communities consideration is being given to the possibility of employing a 10-20 line automatic exchange with reduced subscribers' facilities permitting the use of simple equipment requiring a minimum of maintenance attention.

Manufacturers' existing designs are being studied in respect of their suitability together with preliminary consideration of possible new designs.

#### **UNIT INSTALLATION OF NON-DIRECTOR EXCHANGES.**

With a view to simplification of equipment, consideration is being given to the possibility of unit installation of non-director exchanges with a multiple range of 400-2000 and suitable for replacing the larger types of U.A.X.

### **Main Lines**

#### **CONVERSION OF 12-CIRCUIT CARRIER ROUTES TO 24-CIRCUIT WORKING**

Most of the 12-circuit carrier routes are scheduled for conversion to 24-circuit working and in April,

1947, this work was commenced on the London-Derby Nos. 2 and 3 and the Derby-Manchester Nos. 4 and 5 cables. The conversion of the line amplifier equipment was completed on the latter route in August, 1948, and the London-Derby route finished in September. The provision of the necessary group combining and separating filters, amplifying and channel equipments at London, Derby and Manchester is in hand, and it is anticipated the circuit capacity of these two routes will be doubled by the end of this year, followed closely by Derby-Birmingham, London-Oxford, London-Southampton and Bristol-Salisbury.

As is well known, 12-circuit working employs line frequencies from 12 kc/s to 60 kc/s and the maximum spacing between adjacent repeater stations is 22 miles. For 24-circuit working the frequency range will be extended to 108 kc/s and due to the higher attenuation of the cable pairs at this frequency the repeater station spacing must be reduced, the maximum being 15.5 miles. The conversion of the lines, therefore, consists of the provision of new repeater stations (and on some routes the removal from circuit of certain existing stations) in order to provide amplifying equipment within the new limit of 15.5 miles. In addition, as most of the routes to be converted were equipped initially with carrier system No. 5 or No. 6 type amplifiers—capable of amplifying only the 12-60 kc/s band—these have to be replaced with the more modern No. 7 type amplifier which is satisfactory up to 108 kc/s. Most of the converted routes will, therefore, have new amplifying equipment at all stations.

The cut-in of a new station on a working route has presented some interesting problems. The carrier cables are intercepted and extended into the new building and terminated on standard cable terminating bays equipped with D.E.X.T. balancing frames. Continuity between the two ends of each cable is maintained by a short length of cable connected pair-to-pair at the rear of the test tablets. The D.E.X.T. condensers are all set to zero. The amplifying equipment is now installed and cabled to the cable terminating bays, the equipment U-links having first been removed. The actual insertion of the equipment requires merely the removal of the pair-to-pair connection at the rear of the test tablets and the insertion of the U-links. In the early planning stages it was envisaged that excessive group-to-group cross-talk would exist during the cut-in period of the amplifiers, due to the level difference between amplified and unamplified pairs and the "skip" path provided by the latter, and that in consequence the whole route would have to be released from traffic as each station was dealt with. In practice this forecast has proved to be unfounded, no serious cross-talk having been observed during the cutting in of any station to date. Wherever possible, the new equipment at the station adjacent to the new one is brought into use at the same time as the new station itself. The correct equaliser and amplifier settings for both stations are determined in advance by measurements on a spare cable pair, the characteristics of all 24 pairs being so consistent that it is found possible to apply the settings thus obtained to each of the 24 equipments at any one station. After both cables have been

measured and the equipments adjusted accordingly, the cut-in is performed, pair-by-pair, one cable at a time. By means of patching cords on the cable test bays at the stations on either side of the new one, the spare pair is used to make good each working group in turn whilst the pair proper to the group is being dealt with. By this means it is found possible to cut in all 48 equipments, i.e. both cables, at a new station and change to new equipments at the adjacent stations in less than two hours, this time including a single-frequency check-test on each pair prior to its return to traffic. A break of very short duration is, of course, made in each working group during the patching operations. The work is planned to be carried out during periods of light traffic and no serious inconvenience is caused on speech channels, but to avoid possible complaints from V.F. telegraph users any such systems in the cable are switched to their reserve prior to a new station cut-in. Synchronisation of the patching operation at the two stations concerned is obviously important and this is accomplished by both stations, together with the new one, being provided with a loudspeaker telephone connected at all three stations to a double-phantom circuit, the operation being controlled from the new station.

The introduction of a new repeater station destroys the cross-talk balance of the cables and each new repeater-section will need rebalancing. This operation will be made with test frequencies outside the normal carrier range and will not necessitate the removal of the groups from traffic.

The new repeater station buildings are of very pleasing design. They will accommodate equipment sufficient for two 24-circuit systems and one co-axial cable and will be provided with unattended type automatic power plant. To avoid delays to route conversions, due to buildings not being ready in time, two mobile stations similar to those constructed during the war are in hand and will be completed shortly.

It has been stated that most of the routes, when converted, will have new equipment at all stations. In every case the new "vibration testing" technique has been applied as part of the acceptance tests. It is confidently expected, therefore, that 24-circuit conversion will not only provide 576 circuits on a complete system but also a very reliable service on the circuits themselves.

#### A NEW DESIGN OF COAXIAL CABLE

In furtherance of the programme for providing a nation-wide coaxial cable network, a new cable is now being planned for a Birmingham-Manchester link via Stoke-on-Trent.

This cable will differ from the standard coaxial cables now being laid on many routes in containing six 0.370 in. coaxial tubes instead of the normal two or four. Four of the tubes will be used initially to provide long-distance telephone circuits, and the two additional tubes are being included to cater for future development.

As indicated in the illustration the six coaxial tubes will be laid up around a core of audio pairs, and the interstices between the tubes will also be filled

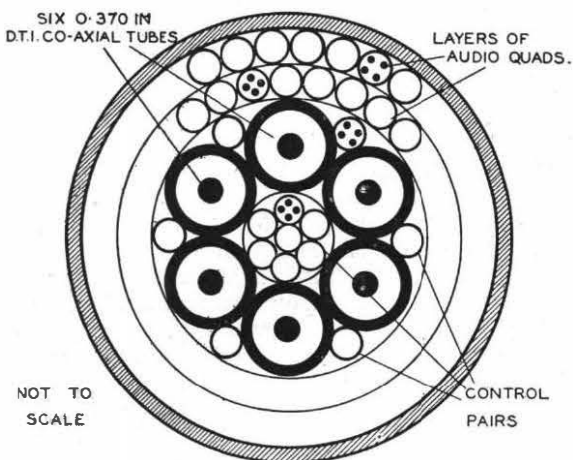

with audio pairs which will be used for the control of the intermediate amplifiers. Layers of quads will also be provided around the tubes to cater for short-distance audio circuits on the route.

### Radio Development

#### TELEVISION CIRCUIT FOR THE OLYMPIC GAMES.

The recent televising of the Olympic Games from Wembley gave a considerable boost to British television in the eyes of the many foreign visitors and it is interesting to note that the Post Office was responsible for the cable circuits and the associated equipment used for conveying the picture signals from Wembley to the television transmitter at Alexandra Palace. For previous television broadcasts from Wembley the signals have always been transmitted by the B.B.C. using their outside broadcast radio link but for this occasion, in view of the importance of the broadcast and the considerable number of hours of programme material to be provided, a cable link was sought by the B.B.C. This was provided by laying a coaxial cable from the special television control room at Wembley to the new Wembley exchange building, thence via Elgar, Ladbroke and Cunningham to Museum exchange; from here the signal was passed to Broadcasting House and then over the existing balanced pair cable to Alexandra Palace. The cable between Wembley (Corinthian) and Museum exchanges was the first example of coaxial tubes being included in a junction cable, the composite cable comprising two 0.370-in. coaxial tubes with 16/20 P.C.Q. interstice pairs surrounded by 468/20 P.C.Q.T. junction pairs. Between the television control room at Wembley and Broadcasting House transmission was carried out using the double-sideband carrier

system previously described in the Journal<sup>1</sup>, with intermediate repeaters at Wembley, Ladbroke and Museum exchanges. The signal was demodulated at Broadcasting House and passed forward at video frequency in the usual way. Altogether some 100 hours of programme material were passed over the new cable circuit during the course of the Olympic Games.

#### A NEW RADIO TELEPHONY TERMINAL

The expansion of the overseas radio telephony services has made it necessary to replan and extend the technical control terminal for these services, and the present terminal at Faraday Building will eventually be replaced by a new one, at Brent Building, which will cater initially for 48 circuits. At the terminal (where the technical operator controls the radio circuit) the lines to the radio transmitting and receiving stations are combined and extended as 2-wire circuits through Overseas exchange to the inland telephone network.

The new equipment is to include automatic level adjusting devices which will make continuous monitoring and manual gain control of circuits unnecessary. In addition, circuits can be extended to a concentrator position which can monitor any working circuits in a group of 24. The operating positions will be remote from the apparatus bays and an operator will be able to control more than one circuit.

In addition to the equipment mentioned above, the Brent terminal will have three programme positions with facilities for handling the complex circuit arrangements required when broadcast programmes are relayed over radio telephone circuits. A programme position made by the Post Office Factories Department

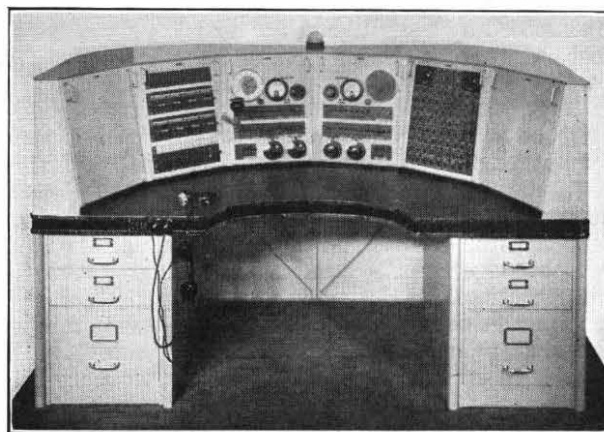

is shown in the photograph. A fully equipped studio will also be provided, from which broadcasts may be originated or which may be used for recording purposes.

<sup>1</sup> P.O.E.E.J., Vol. 40, p. 33.

# Regional Notes

## Midland Region

### MECHANICAL AID FOR CABLE LAYING

The provision of telephone service to farmers by normal methods in these days of restricted labour and materials is slow and costly but some improvement has resulted from the use of mechanical aids.

It has been found possible in the Leicester Area to hire a trench excavator—the "Roteho"—with driver, for short periods between works on land drainage schemes. The chief features of the "Roteho" are:

- (1) It is designed to be fitted to the standard Red Spot Fordson Tractor (24 h.p.) only.
- (2) It is supplied complete with tractor reduction gear-box and power take-off.
- (3) Machine requires tractor driver only to operate.
- (4) Standard width of cut is 7 in.
- (5) Depth from 20 in. to 36 in.
- (6) Working speed 220 yards per hour.
- (7) Depth control is simple and positive.
- (8) Cutting blades can be re-dressed at small cost.
- (9) By simple movement of lever on reduction gear-box standard travel gears on tractor are restored.
- (10) All bearings are heavy duty ballraces and all working parts are entirely enclosed and running in oil.

The machine as illustrated is intended for use in clay subsoils but it will, nevertheless, operate satisfactorily in soils containing a fair percentage of gravel or small stone, or in boulder clay and chalk. The overall width



of the machine is 6 feet and it will operate on reasonably level ground. The excavated soil is deposited along the side of the trench within the width of the machine; thus it does not cause any objectionable obstruction to other road users.

It can be operated along grass verges and tar-paved footpaths from 3 ft. upwards in width (dependent upon the stipulation of the road surveyor as to the distance between the trench and the metalled roadway). The digging unit consists mainly of a wheel 5 ft. in diameter, to which are attached 12 equally spaced blades bolted to the outer flange of the wheel.

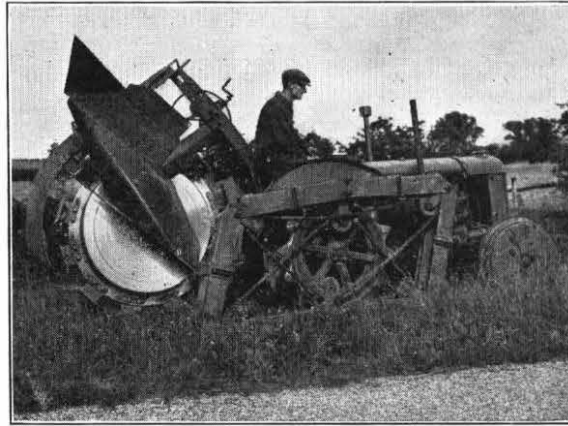

The scheme selected for trial would have involved the erection of approximately 5,000 yards of aerial cable on existing pole routes which required strengthening, but this was revised to provide for ex-Army cable laid direct in the trench dug by the Roteho at a depth of 24 in.

At the time of writing, 3,971 yards of trench has been excavated, cable laid, and trench filled in, in 14 days. The Post Office labour involved 1,206 manhours, i.e., .3 manhours per yard. The filling-in of the trench created some difficulties. By hand the progress is far too slow and a local device, using existing transport on site, was used and proved to be very effective, 80 per cent. of the excavated soil being replaced by this means.

On the last day of the trial, whilst filling-in was in progress on the last section of the cable direct in ground, a further trial was made on the use of the machine for laying duct. A section of 208 yards of 3 in. S.A.D. was selected and the machine excavated the trench 24 in. deep in 3 hours. The ducts were laid with 21 in. cover without difficulty from a handling point of view, but the standard rate of progress using this type of duct could not be improved upon; consequently, if the machine is used to its full extent, long sections of trench would have to remain open. This, of course, is undesirable. However, by using 2 in. or 3 in. asbestos cement ducts, the rate of progress could be considerably improved.

Engineers engaged on planning will realise the economic possibilities to be obtained from using this type of machine for laying cable direct in the ground in lieu of aerial cable, and from its use on duct work in suitable localities. On the scheme described approximately 100 poles will be made spare and recovered; in addition there is saving in line stores and maintenance costs.

G. A. P.  
G. A. Y.

[Note.—The E.-in-C. has ascertained that the manufacturers ceased production some time ago and do not propose to re-commence. The further use of such machines is therefore now dependent on ability to obtain the loan or hire of machines already in use for agricultural purposes during times when they would otherwise be out of use.

The foregoing should therefore be regarded in the nature of an isolated trial pending the development of similar machines.]

## South Western Region

### SHAFTESBURY AUTOMATIC EXCHANGE

History attributes great antiquity to the ancient market town of Shaftesbury. Situated on a high hill in the northern extremity of Dorset, it commands extensive views over the fertile farmlands of Dorset, Somerset and Wilts. King Alfred rebuilt the City after it was destroyed by the Danes, the buildings being generally of stone dug out of the hill. The most recent addition to the town is an imposing stone-faced building, of architecture in keeping with the best traditions, housing the new automatic telephone exchange.

The exchange, which replaces the old C.B.S. No. 2 exchange, is equipped with 600 multiple and 460 calling equipments and acts as parent for East Stour, Fontmell Magna, Donhead and East Knoyle U.A.X.s, the last two being recently converted to U.A.X.13 type as part of the transfer scheme. The U.A.X.s have access to the Shaftesbury subscribers and inter-dialling facilities via the Shaftesbury equipment, as well as access to certain of the adjacent manual exchanges. The 2,000-type non-director equipment and 11-position manual board were installed by Ericsson Telephones Ltd.

A regrouping of the surrounding exchanges was made and Shaftesbury converted to a group centre for traffic routing. Existing junction routes were augmented and some new routes set up.

The 104-pr. Shaftesbury-Salisbury and the 122-pr. Shaftesbury-Yeovil cables now terminate in the new exchange, and the Salisbury-Yeovil cable has been intercepted and 152 pairs led into Shaftesbury. At East Stour repeater station the Shaftesbury-Yeovil cable was cut in and 100 pairs terminated. Additional amplifiers have been installed at East Stour in order that a maximum of 48 4-wire circuits could be provided. To allow the new Sturminster Newton-Shaftesbury route to be set up with amplifiers at East Stour a 74-pr. spur of the Salisbury-Yeovil cable was terminated at Sturminster Newton.

On 25th June, 1948, the auto-manual board was opened with the U.A.X.s and a proportion of the manual junction traffic transferred to it. Tie circuits were provided between the old and new exchanges.

On the 9th July, the Shaftesbury subscribers and the remainder of the junctions were transferred to the new exchange; the transfer was smooth and no difficulty was experienced. The official opening ceremony, held on the 13th July, was attended by the Mayor of Shaftesbury and members of the Council, the Head Postmaster, the Telephone Manager, and a representative gathering of P.O. officials. After the company had been entertained to lunch, the Mayor made a token call to the Mayor of Dorchester, the conversation being broadcast to the assembly.

Thus one of the oldest centres of our farming communities, on which the need for increased production is so strongly stressed by present conditions, is now served by modern communication equipment.

### MAJOR TURN-ROUND SCHEME AT GLOUCESTER EXCHANGE

Installation of equipment to effect a turn-round at Gloucester under a contract extension has been completed satisfactorily. A new building on the same site as the old was erected prior to the outbreak of the war; access between the buildings was provided at certain points on the stairway.

The equipment in the old building consisted of 3,200 multiple automatic equipment on line and final units with double-sided selector racks, 38 auto-manual switchboards, relay sets, two M.D.F.s, two I.D.F.s, two test

desks and power plant.

The extension (all of 2,000-type equipment) includes equipment for replacement of all relay set racks, tandem switching, main and intermediate distribution frames, and an additional automatic multiple of 1,600, new power plant and a testing suite. For economic reasons it was considered desirable to retain the subscribers' equipment in use for a few more years and temporarily the subscribers' multiple is spread over two types of equipment. To give full flexibility of line plant, the old final units have been recabled to the new M.D.F. It is hoped to replace the remainder of the old equipment under a subsequent extension.

The old 1st selectors have a digit absorbing feature operative on level 2. Prior to the extension, the numbering scheme was of 4 digits so that the feature was effective on 25 per cent. of all calls. Conversion to a 5-digit scheme, to permit greater flexibility in the numbering scheme without introducing a mixed 4- and 5-digit scheme, has increased the effective use of digit absorbing to all local numbers. The increase from 4 to 5 digits was actually effected by prefixing digit 2, without addition to the old type of equipment. Arrangements were made to change the discriminating selectors at a satellite exchange to convert to 5-digit working.

The auto-manual switchboard had already been extended as a separate suite into the new building, but was cabled from the suite of 38 positions in the old building. The multiples were cut at a point where they were bridged, between two cable-turning sections, and the two portions terminated as separate suites on the I.D.F. Associated lamp racks, relay sets and miscellaneous services were diverted to the new exchange at the same time.

It would not be within the scope of these notes to describe the difficulties associated with a scheme of this magnitude or to detail the careful planning necessary to overcome or avoid them but it is gratifying to record completion of the work without interruption to the service. The Telephone Manager's staff which made all arrangements necessary on the trunking of the old equipment, including transfer of external plant, and the contractors, Automatic Telephone & Electric Co., Ltd., are to be congratulated on the co-operation and planning which has given such a satisfactory result.

M. C. S.

## Home Counties Region

### AN UNUSUAL SUBSCRIBER

When it became necessary over 30 years ago to provide a telephone in the lighthouse at Beachy Head, a very different problem arose from that of an ordinary subscriber on *terra firma*. For one thing, the length of the span to the lighthouse and the exposed position were a little out of the ordinary, and the question of a suitable metal for brackets to withstand the corrosive action of the sea had to be considered.

The span is approximately a quarter of a mile long and is of 300 lb. copper. For the fixing at the lighthouse a bronze spindle was made and cemented in the stonework immediately below the gallery. It has been in use for 30 years or more and is still good for another 30. At the shore end, a 38-ft. medium pole (with transverse and back stays) was erected at the top of the cliff, 20 yards from the edge at a point where a concrete parapet was built to lower the materials to the foot of the cliff for building the lighthouse. Aerial type insulators are used and the fixings on the pole consist of two U-shaped brackets connected by an arm bolt through the pole.

The circuit was originally a private wire to the signal station about  $\frac{1}{2}$  mile distant, but recently it was converted to a direct exchange line. The circuit between the light-



house and the signal station is single wire, earth return and a Unit A.A. No. 18 at the signal station converts to a two-wire unit to Eastbourne exchange.

During the war the span was brought down two or three times by aircraft without injury to the latter. When erecting a new span the end of the wire is lashed to an oil drum, and is paid out over the cliff and floated to the lighthouse. This can, of course, only be done at low tide when access to the base of the cliff is possible but even then the time is limited, and a  $\frac{1}{2}$ -mile walk is necessary before a path is reached which gives access to the top of the cliffs.

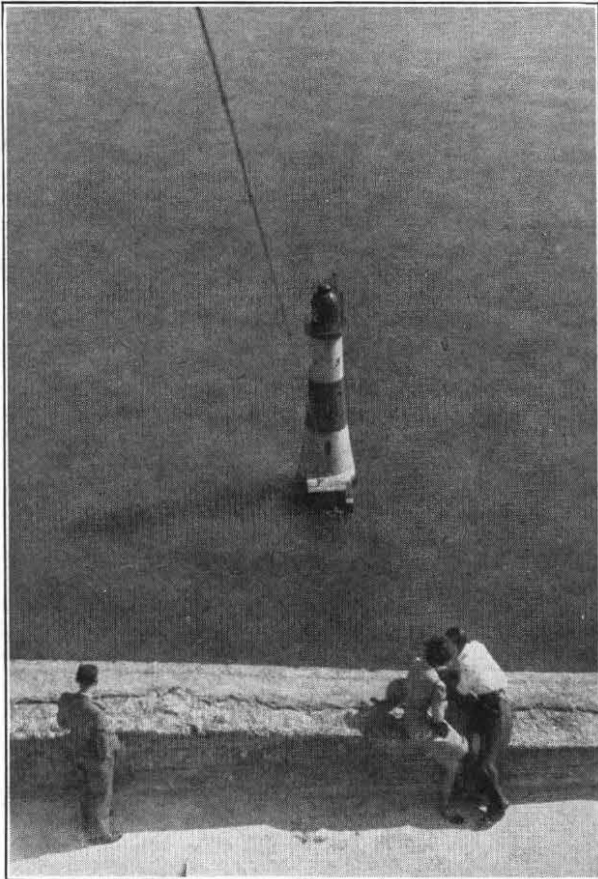

The accompanying photograph taken from the pole gives some idea of the abnormal conditions which had to be met.

#### THE "CABLE SPECIAL"

Many visitors to the Isle of Wight will remember the "main" railway line from Ryde to Newport, much of it single-track. A pole route, originally built for telegraph purposes, jointly used by the old Isle of Wight Railway Company and the Post Office, has been in existence along this line for over fifty years. As a good proportion of the original poles were still in service, it is not surprising that some of them proved "suspect" on a comprehensive examination. The long-term plan for the elimination of this route involves the provision of a considerable amount of duct-work, and under prevailing conditions it was decided to defer the provision of the duct by laying a temporary cable at the side of the footpath beside the permanent way.

After admirable co-operation from the British Railways (Southern Region) a special train was arranged, consisting of engine, three 10-ton open type goods wagons, and a brake van. Eight cable drums each containing 1,000 yards of cable (28/20 or 14/20 according to requirements) were mounted in the wagons with battens removed and ready for jacking-up. The cable was ex-Army surplus, A.S.P.C. with tarred hessian lapping over the lead sheath as a protection. Two portable electric lighting plants of the "Tiny Tim" variety were provided on one of the wagons, as the operation had, naturally, to be carried out during night hours when the line was reasonably free from traffic. Careful preliminary organisation was necessary to draw up a running time-table, and definite stops were arranged for the purpose of cutting the cable at level crossings (where a duct for protection of the cable will be provided), points frames, signal operating gear and similar obstacles to continuous cable laying. Similarly, stores such as ducts, markers and steel capping were arranged in the wagons so that they could be dropped off where required according to a pre-arranged schedule.

On the evening of 22nd July, 1948, the supervising officers and the working party, consisting of two foremen, five men, a jointer and mate, assembled at Newport station and took possession of the "Cable Special." The train crew consisted of driver, fireman and guard, and it should be stated here that the clever handling of the train on gradients and curves, so that "shunting shocks" were practically eliminated, contributed materially to the success of the operation. The train ran to Wootton Bridge station, where cable laying began at 10.20 p.m.

The cable as it came from the drum, was led out through the side of the truck, the side-flap being dropped to afford a clear exit space. The operation proceeded without a hitch throughout the night, interrupted only by the planned stops previously referred to, for cutting and sealing the cable, and by two retreats to sidings to leave the line clear for night trains. The cable came steadily and safely off the drums, and although at times the workers on the line side had to display some extra agility to dispose of the cable bight as it left the train, no undue difficulty was experienced. It was noticed that the chalk-powder from the cable protection was inclined to cause some discomfort to the eyes of those stationed at the drums in the wagons, but this contingency had been foreseen by the Planning Group, and a supply of ex-A.R.P. eye-shields was available for those requiring them.

By 5.0 a.m. on the morning of 23rd July, the train arrived at Ryde, St. John's station, some 5 miles of cable having been laid during the night. About  $1\frac{1}{4}$  hours were gained on the scheduled time-table, time being saved on long straight runs where no cuts of the cable were necessary. The average laying time for 1,000 yards was 37 minutes, the best time recorded being 20 minutes for this distance.

Had it been necessary to man-handle this cable along the railside, a costly and protracted operation would have been unavoidable, in view of the difficulty of access for normal cabling operations on embankments and in deep cuttings. Some £130 in labour costs alone have been saved by the methods adopted.

F. J. G.

#### EQUIPMENT FOR VIBRATION TESTING OF REPEATER STATION APPARATUS

The recent development by the Transmission and Main Lines Branch of the Engineer-in-Chief's Office of the vibration method of testing repeater station equipment created the need for the urgent supply of high-gain

loudspeaker amplifiers. The transmission staff at Guildford had previously constructed suitable, if somewhat elaborate, equipment for this purpose and 15 further sets of simpler design have now been made in the Guildford workshops. The design of the amplifiers was evolved by the Guildford staff under the guidance of the Area Transmission Officer; Regional transmission staff also co-operated, especially in testing the suitability of the amplifiers. The first nine were completed and distributed within a few weeks and have been in use for some months.

The amplifier is mains operated and contains two high-slope pentodes and a beam tetrode output. Careful screening and placing of components was employed to obtain a satisfactory signal/noise ratio and to reduce instability. The gain is such that a tone at -90 db. is clearly audible in the loudspeaker which is a Goodman 5 in. (permanent magnet) mounted in a standard wooden battery box. To reduce coupling between input and output circuits, screened flexible leads are used for all external connections.

To employ the vibration testing technique at carrier frequencies (e.g. 40 kc/s) simple modulators and demodulators were also constructed, using small metal rectifiers (Westectors). The demodulator, which consists of a full-wave rectifier bridge, has the additional property of very considerably reducing the tendency to howl, which is otherwise caused by acoustic coupling between loudspeaker and the carrier amplifier under test.

C. J. S.

### London Telecommunications Region

#### UNUSUAL WORK FOR POWER SECTION WORKSHOPS

One of the functions of the Power Section workshops is to provide those engineering items required in the Region which cannot be purchased by the time they are needed and which are required in small numbers only. The output of the workshops, therefore, has always been of an extremely varied character. Now that contractors, for reasons largely beyond their control, are showing an increasing reluctance to undertake single items outside their normal range of products, the workshops are being called upon for work far more exacting than anything contemplated previously.

A jig which would normally be ordered from a firm equipped with high-grade precision machines of tool room standard and which had to be made in the Power Section workshops is shown in the accompanying photograph.

This jig will be used in the Region's Piece Part Depot

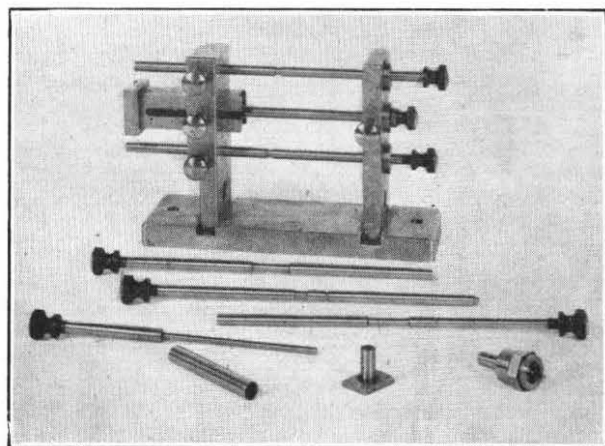

when rotary line switches are re-assembled after dismantling for overhaul and repair. It will accommodate switches of three different makes and the tolerance allowed on many of the dimensions was as little as .0001 in.

#### MIDDLESEX HOSPITAL P.A.B.X.

In response to a request from the Middlesex Hospital for additional auto extensions to their P.A.B.X., it was decided to replace the existing 110-line R.A.T. equipment by a 400-line P.A.B.X. with linefinders manufactured by the A.T. & E. Company. Such an equipment was found to be available in a disused Royal Ordnance factory in Wales and this was transferred by Departmental road haulage and duly installed after cleaning up on site.

Due to the design of the auto equipment it was necessary for each auto extension to have an answering appearance in the manual board and, having regard to the personal nature of the traffic at the hospital, the auto-manual board originally designed for this equipment was unsuitable. It was accordingly decided, with the Engineer-in-Chief's approval, to install a suite of four P.M.B.X. 1As as a manual board, giving multiple repetition every four panels and using standard 1A equipment for exchange lines. Two separate single-float battery installations are employed, one of 24 volts for the 1A equipment and one of 48 volts for the auto equipment.

The use of two different battery voltages called for special circuit arrangements in order that the standard engaged test could be given. This also involved the fitting of metal rectifiers to prevent the immediate operation of the calling lamp on the manual board when the extension user lifted the receiver. The change-over from the old to the new equipment took place at 1.30 p.m. on Saturday, 19th June, 1948, to the satisfaction of all concerned.

A. E. L.

#### MULTI-METERING AT DIRECTOR EXCHANGES TO AUTO. EXCHANGES IN 12½-20 MILES BELT

Subscribers connected to most London director exchanges already have the facility of dialling to all automatic and manual exchanges inside the director area (12½ miles circle). There are, however, a number of automatic exchanges in the 12½-20 miles belt to which director subscribers cannot dial. These exchanges are all within 4th fee range of director exchanges in the 5 mile circle and only a few are beyond 4th fee range of some director exchanges in the 5-12½ miles belt.

It has recently been decided to introduce a scheme so that subscribers at most director exchanges can dial to any of the automatic exchanges mentioned which are within 4th fee range. The scheme required the provision of routes to Toll "A" (N.D.) automatic exchange from code levels of director exchanges, with Toll "A" functioning as a tandem exchange. The outgoing routes at Toll "A" to the automatic exchanges in the 12½-20 miles belt have already had regenerators provided as this traffic was previously "tandem-dialled" via Toll "A" by the director exchanges' auto-manual board operators. Dialling-out by subscribers to manual exchanges in the 12½-20 miles belt is not included in the scheme because "guarded metering" conditions cannot be given satisfactorily without providing separate "guarded metering" and "full supervisory" routes outgoing from Toll "A" to each manual exchange concerned.

Initially the scheme has been introduced, experimentally, at a few director exchanges in the 5 miles circle and these exchanges are Cunningham, Kensington and Waterloo. It will also be introduced at Terminus

later and then further extension of the scheme will be the subject of review after six months' experimental working at the director exchanges mentioned.

There are 25 automatic exchanges in the 12½-20 miles belt and they consist of 24 non-director, and 1 U.A.X. No. 14. All have 4-digit numbering schemes except Slough which has 5 digits (commencing with the digit 2).

Dialling-code cards were issued to the director exchange subscribers and the codes chosen consist of the first two letters of the objective exchange name followed by an arbitrary digit, e.g. AS-9 for Ashford (MX). In the exceptional case of Slough, a two letter code—SL—was published, but the code received by the A-digit selectors and directors will include the wanted subscriber's initial digit 2, e.g. SL-2.

R. C. W. W.

### Welsh and Border Counties Region

#### C.B.10 EXCHANGES—IMPROVISATION IN CONSTRUCTION

Several C.B.10 exchanges are in process of construction in this Region and difficulties of supply have led to the adoption of some interesting expedients.

One of these concerns the provision of combined distribution frames. The Stores Department's stock being exhausted, the whole manual relief exchange programme would have been delayed but for the offer of frame units made available by the disposal of semi-automatic emergency equipment. The I.D.F. portion of these frames was designed for three instead of the usual four tagblocks and were modified by the provision of a bar welded to the ends of the three horizontal members so as to allow four tagblocks to be fitted in the space intended for three, thus permitting standard cabling arrangements to be employed. Three exchanges with a total of 108 verticals have been equipped in this way.

Standard cable racking, also available from semi-auto stock, has been adopted and used on these installations. No bends were available, but these were manufactured from locally purchased steel, using slats from the standard racking.

To economise in switchboard cable one exchange has been laid out so that the switchboard positions on the first floor are in line with the C.D.F. on the ground floor. A slot in the first floor underneath the length of the suite of positions allows a series of very short vertical runs for cables from the answering jacks to the connection strips on the C.D.F. below.

S. E. N.

#### DAMAGE TO POLES BY WOOD-BORING BEETLE LARVÆ

During pole testing operations near Cardigan, a new enemy was discovered. Measuring about ½ in. overall, he is a handsome fellow of light brown colour, striped and clouded with black. Each elytron or wing casing is crossed by two curving bands of yellow. Entomologists know him as *Rhagium Bifasciatum*, one of the great family of Cerambycidae or Long-Horned Beetles. *Rhagium* usually confines his attentions to decaying pine stumps, and telegraph poles appear to be an unwelcome departure from normal diet.

Mr. E. B. Britton, of the Department of Entomology, British Museum, assures us that *Rhagium* would not attack a sound pole. There is evidence, however, that the female beetle will enter freshly-bored holes that extend beyond the creosoted wood, especially in poles that have been *in situ* for some years and have become weathered. Once inside, Mrs. *Rhagium* deposits her eggs that will emerge as larvæ, ready and willing to consume prodigious amounts of timber before undergoing metamorphosis to the stage of the pupæ.

So far, only "K" poles have been found affected and these are confined to a relatively restricted area. It is, however, too early to conclude that other poles are not prone to attack, or that beetle damage will not be found in other parts of the Area. Attacks can be prevented in sound poles by a liberal application of creosote and tar to all fresh cuts or bores, and by plugging all bore-holes and arm slots.

The accompanying photograph shows the extent of damage to a pole that has been attacked.

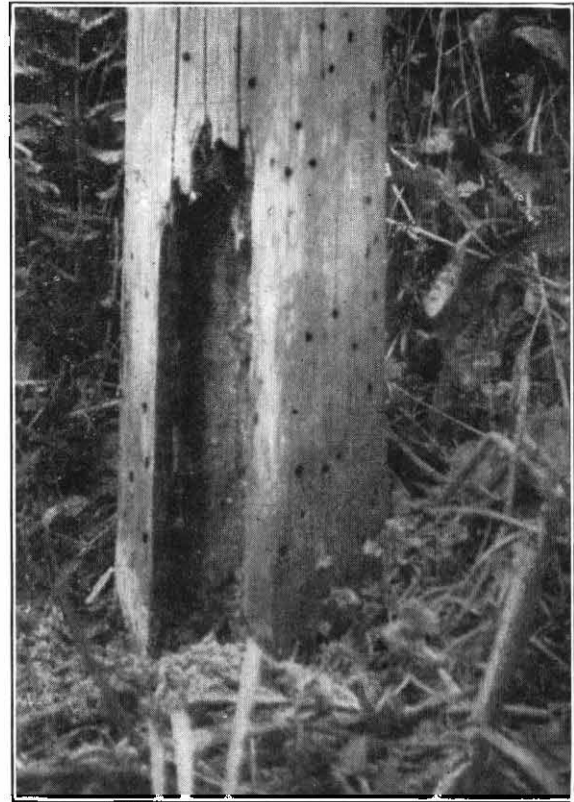

In a few short weeks, the larvæ of *Rhagium* can transform a pole classified as "S" into a potential accident trap for an unwary lineman.

J. S.

### Scottish Region

#### THE HIGHLAND SHOW

"The Highland Show" was held in Inverness from the 22nd to 25th June.

As was anticipated, a number of exhibitors required temporary exchange lines before and during the Show. Inverness has very little spare plant but a main underground cable within half a mile of the show ground permitted the connection of approximately 50 circuits of various types. In addition to the mobile Post Office with two teleprinters and two call offices, a suite of 12 cabinets for public call offices was provided. Seven direct exchange lines and thirty-eight shared service circuits were provided for the exhibitors. In addition, three Press, two B.B.C., and two service circuits were in operation. Distribution to the various stands and the satisfactory coupling up, from the exhibitors' point of view, of the shared service lines, presented many difficulties, but these were overcome and a satisfactory service maintained during the period of the Show.

W. H.

# Staff Changes

## Promotions

Name	Region	Date	Name	Region	Date
<i>Exec. Engr. to A.S.E.</i>			<i>Asst. Engr. to Expt. Off.</i>		
Brett, S. I. .. ..	E.-in-C.O. .. ..	1.6.48	Allen, T. R. .. ..	E.-in-C.O. .. ..	1.8.48
Gill, O. W. .. ..	E.-in-C.O. .. ..	13.5.48	Burralls, W. .. ..	E.-in-C.O. .. ..	7.6.48
Hayes, H. C. S... ..	E.-in-C.O. .. ..	12.6.48	Butterworth, J. .. ..	E.-in-C.O. .. ..	24.5.48
Knox, A. H. C. .. ..	L. T. Reg. to H.C. Reg.	18.6.48	Campbell, D. A. .. ..	E.-in-C.O. .. ..	24.5.48
<i>Engr. to Exec. Engr.</i>			Cawthra, W. A. .. ..	E.-in-C.O. .. ..	14.6.48
Billen, J. C. .. ..	E.-in-C.O. .. ..	12.6.48	Cole, J. F. .. ..	E.-in-C.O. .. ..	24.5.48
Bomford, K. D. .. ..	E.-in-C.O. .. ..	12.6.48	Ephgrave, E. V. .. ..	E.-in-C.O. .. ..	7.6.48
Crow, D. A. .. ..	E.-in-C.O. .. ..	29.5.48	Frost, E. J. .. ..	E.-in-C.O. .. ..	24.5.48
Ireland, J. C. .. ..	E.-in-C.O. .. ..	1.6.48	Hayward, G. O. .. ..	E.-in-C.O. .. ..	24.5.48
Rattue, P. J. .. ..	E.-in-C.O. .. ..	1.6.48	Hewlett, F. M. .. ..	E.-in-C.O. .. ..	7.6.48
Saville, W. .. ..	E.-in-C.O. .. ..	13.5.48	Kauffman, B. .. ..	E.-in-C.O. .. ..	1.8.48
Webber, F. W. J. .. ..	S.W. Reg. to E.-in-C.O.	16.8.48	Milne, F. A. .. ..	E.-in-C.O. .. ..	24.5.48
Smith, C. N. .. ..	L. T. Reg. .. ..	18.6.48	Steed, C. A. .. ..	E.-in-C.O. .. ..	1.1.46
<i>Asst. Engr. to Engr.</i>			Thompson, J. .. ..	E.-in-C.O. .. ..	7.6.48
Harden, P. .. ..	L. T. Reg. .. ..	26.7.48	Yemm, H. .. ..	E.-in-C.O. .. ..	24.5.48
Ingram, E. A. .. ..	E.-in-C.O. .. ..	26.7.48	<i>Tech. to Expt. Off.</i>		
Orde, J. R. .. ..	N.E. Reg. to N.W. Reg.	14.8.48	Hollins, G. T. .. ..	E.-in-C.O. .. ..	24.5.48
Sharpe, H. N. .. ..	Mid. R. .. ..	26.7.48	Johnson, C. B. .. ..	E.-in-C.O. .. ..	7.6.48
Teale, J. C. C. .. ..	N. E. Reg. .. ..	26.7.48	<i>E. O. to Expt. Off.</i>		
Willson, J. C. .. ..	E.-in-C.O. .. ..	5.6.48	Lovegrove, E. A. .. ..	L.P. Reg. to E.-in-C.O.	1.6.48
<i>Insp. to Asst. Engr.</i>			<i>Fifth Engr. to Fourth Engr.</i>		
Stears, A. D. S... ..	E.-in-C.O. .. ..	12.4.48	Talbot, F. C. .. ..	H.M.T.S. <i>Monarch</i> ..	13.5.48
<i>Technician to Asst. Engr.</i>			<i>D'man Class II to D'man Cl. I</i>		
Ash, B. .. ..	Mid. Reg. to E.-in-C.O.	21.6.48	Armstrong, W. J. .. ..	E.-in-C.O. .. ..	27.6.48
Banham, H. .. ..	N.W. Reg. to E.-in-C.O.	4.7.48	Key, H. J. L. .. ..	E.-in-C.O. .. ..	1.6.48
Officer, J. E. .. ..	N.W. Reg. to E.-in-C.O.	4.7.48	Manners, H. F. .. ..	E.-in-C.O. .. ..	1.6.48
<i>Engr. to Sen. Expt. Off.</i>			Kendall, E. C. .. ..	E.-in-C.O. .. ..	20.6.48
Chandler, W. W. .. ..	E.-in-C.O. .. ..	24.5.48	Race, C. .. ..	N.W. Reg. .. ..	27.6.48
<i>A.T.S. to Sen. Exp. Off.</i>			Jones, H. E. .. ..	N.W. Reg. .. ..	27.6.48
Griffiths, D. C. .. ..	W. & B. C. Reg. to E.-in-C.O.	14.6.48	Blaylock, A. C. .. ..	N.W. Reg. .. ..	25.4.48

## Transfers

Name	Region	Date	Name	Region	Date
<i>Prob. Engr.</i>			<i>Asst. Engr.—continued</i>		
Garlick, J. .. ..	E.-in-C.O. to Min. of Transport .. ..	26.7.48	Eades, R. A. .. ..	E.-in-C.O. to Min. of Supply .. ..	8.6.48
<i>Asst. Engr.</i>			Elliott, R. L. .. ..	E.-in-C.O. to Min. of Supply .. ..	8.6.48
Cheek, P. .. ..	E.-in-C.O. to Min. of Supply .. ..	25.7.48	Blanchard, A. J. .. ..	E.-in-C.O. to Min. of Supply .. ..	8.6.48
Stone, K. A. .. ..	W. & B.C. Reg. to N.E. Reg. .. ..	1.6.48	Bryan, B. H. .. ..	E.-in-C.O. to Min. of Supply .. ..	8.6.48
McDaid, N. F. .. ..	E.-in-C.O. to Scot. Reg.	1.6.48	Enwright, J. A. .. ..	E.-in-C.O. to Min. of Supply .. ..	8.6.48
Benson, T. A. .. ..	E.-in-C.O. to Scot. Reg.	13.6.48	Wright, A. .. ..	E.-in-C.O. to Min. of Supply .. ..	8.6.48
Wilson, J. .. ..	Seconded to Malaya ..	6.7.48	Garnett, W. H. .. ..	E.-in-C.O. to Min. of Civil Aviation ..	8.6.48
Partridge, J. E. .. ..	Mid. Reg. to E.-in-C.O.	5.7.48	Rowlands, E. J. .. ..	E.-in-C.O. to N.W. Reg.	8.8.48
Allen, W. G. .. ..	N.E. Reg. to Min. of Supply .. ..	8.6.48	Harris, J. C. .. ..	E.-in-C.O. to N.W. Reg.	1.8.48
Fish, A. J. .. ..	L.T. Reg. to Min. of Supply .. ..	8.6.48	<i>D'man Cl. I.</i>		
Walker, B. A. .. ..	E.-in-C.O. to Min. of Supply .. ..	8.6.48	Watson, W. A. .. ..	H.C. Reg. to L.T. Reg.	23.5.48
Preece, G. H. .. ..	E.-in-C.O. to Min. of Supply .. ..	8.6.48	Guthrie, D. E. .. ..	H.C. Reg. to L.T. Reg.	14.6.48
Roberts, T. N. D. .. ..	E.-in-C.O. to Min. of Supply .. ..	8.6.48	Nicols, D. J. .. ..	N.I. Reg. to H.C. Reg.	14.6.48
Supper, J. B. .. ..	E.-in-C.O. to Min. of Supply .. ..	8.6.48			

### Retirements

Name	Region	Date	Name	Region	Date
<i>Asst. Staff Engr.</i>			<i>Asst. Engr.</i>		
Marr, H. R.	E.-in-C.O.	31.5.48	Hewer, A. G.	L.T. Reg.	4.6.48
Mitchell, C. A.	E.-in-C.O.	9.6.48	Huckle, M. N.	E.-in-C.O. (Resigned)	2.7.48
Ritter, E. S.	E.-in-C.O.	31.8.48	Barrett, H.	L.T. Reg.	21.7.48
<i>Area Engr.</i>			Wooster, C. B.		
McNeill, A.	H.C. Reg.	31.5.48	H.C. Reg. (Resigned) 14.2.48		
<i>Engineer</i>			<i>Inspector</i>		
Bingham, A. H.	S. W. Reg.	31.5.48	Penfold, C. A.	L.T. Reg.	12.4.48
Scott, W. F.	L.T. Reg.	31.5.48	Pollard, A. C.	L.T. Reg.	17.7.48
Neal, N. W.	E.-in-C.O. (Resigned)	31.7.48	Sketcher, J. H.	N.W. Reg.	2.5.48
Williams, C. E.	H.C. Reg.	30.6.48	Snelling, R. C.	H.C. Reg.	30.6.48
Pierson, J. H.	N.I. Reg.	20.7.48	Sanderson, W.	N.W. Reg.	3.6.48

### Deaths

Name	Region	Date	Name	Region	Date
<i>Asst. Engr.</i>			<i>D'man.</i>		
Clarkson, W. J.	N.W. Reg.	22.7.48	Manners, H. F.	E.-in-C.O.	8.7.48

### CLERICAL GRADES

#### Promotions

Name	Region	Date	Name	Region	Date
<i>C.O. to E.O.</i>			<i>C.O. to E.O.—continued</i>		
Bugg, G. L.	E.-in-C.O.	1.7.48	Laidlar, F. E.	E.-in-C.O.	31.7.48
Dudbridge, Miss J.	S.B.D. to E.-in-C.O.	24.5.48	Langfield, F. J.	E.-in-C.O.	1.9.48
Nutter, A. F.	E.-in-C.O.	11.6.48	McEvoy, E. M.	S.B.D. to E.-in-C.O.	15.8.48

#### Transfers

Name	Region	Date	Name	Region	Date
<i>E.O.</i>			<i>E.O.—continued</i>		
Hoare, E. R.	E.-in-C.O. to Min. of Agri. & Fisheries	15.3.48	Ellingham, F. B.	E.-in-C.O. to Min. of Works	3.8.48
Waller, T. W.	E.-in-C.O. to Home Office	8.6.48	<i>C.O.</i>		
Lambert, F.	E.-in-C.O. to Min. of Agri. & Fisheries	16.8.48	Gebbeth, M. G.	E.-in-C.O. to Board of Trade	5.7.48
			Woodford, G. G. R.	E.-in-C.O. to Dept. of Sc. & Ind. Res.	5.7.48

#### Retirements

Name	Region	Date	Name	Region	Date
<i>E.O.</i>			<i>E.O.—continued</i>		
Crossley, L. J.	E.-in-C.O.	30.6.48	Stoner, A. L. W.	E.-in-C.O.	31.8.48

# The Institution of Post Office Electrical Engineers

## London Centre

### PROGRAMME OF MEETINGS—SESSION 1948-49 ORDINARY MEETINGS

To be held at The Institution of Electrical Engineers, Savoy Place, Victoria Embankment, W.C.2, commencing at 5.0 p.m.

Monday, 8th November.—“The Possibilities of Super-H.F. Radio and Wave Guide Systems for Telecommunications,” W. J. Bray, M.Sc., A.C.G.I., D.I.C., A.M.I.E.E.

Monday, 6th December.—“The Cables of the Inland Long Distance Telecommunications Network and their Maintenance,” H. C. S. Hayes, A.M.I.E.E., and E. D. Latimer, A.M.I.E.E.

### INFORMAL MEETINGS

To be held at the L.T.R. Headquarters Refreshment Club, 8th Floor, Waterloo Bridge House, S.E.1, commencing at 5.0 p.m.

Wednesday, 27th October.—“Investigation of Exchange Maintenance and Service Conditions.” S. New.

Wednesday, 24th November.—“The Use of Gas Pressure in Cables.” J. P. Harding, B.Sc., A.M.Inst. C.E., A.M.I.E.E.

Wednesday, 19th January.—“Current Telephone Switching Practice in the U.S.A.” J. A. Lawrence, A.M.I.E.E.

### BOARD OF EDITORS

H. FAULKNER, B.Sc., M.I.E.E., Chairman.  
F. E. NANCARROW, O.B.E., A.R.C.Sc., M.I.E.E.  
P. B. FROST, B.Sc., M.I.E.E.  
A. H. MUMFORD, O.B.E., B.Sc.(ENG.), M.I.E.E.  
C. W. BROWN, A.M.I.E.E.  
C. E. C. SKUSE.  
G. E. STYLES, A.M.I.E.E., Managing Editor.  
J. P. HARDING, B.Sc.(ENG.),  
A.M.Inst.C.E., A.M.I.E.E. } Assistant Editors.  
F. WARREN, A.M.I.E.E.  
A. J. BAKER, Secretary-Treasurer.

### Copyright

The entire contents of this JOURNAL are covered by general copyright, and special permission is necessary for reprinting long extracts, but Editors are welcome to use not more than one-third of any article, provided credit is given at the beginning or end thus: “From the *Post Office Electrical Engineers' Journal*.”

The Board of Editors is not responsible for the statements made or the opinions expressed in any of the articles in this JOURNAL, unless such statement is made specifically by the Board.

### Communications

All communications should be addressed to the Managing Editor, *P.O.E.E. Journal*, Engineer-in-Chief's Office, Alder House, Aldersgate Street, London, E.C.1. Telephone: HEADquarters 1234. Remittances should be made payable to “*The P.O.E.E. Journal*” and should be crossed “& Co.”

A limited number of advance copies of papers to be read at Ordinary meetings will be available a few days before each meeting and application should be made to the Local Secretary, W. H. Fox, Tp. Branch, Alder House (Telephone: MON 1802).

The remainder of the 1948-49 Programme will be published in the next issue.

### Essay Competition, 1947/48 Results

Prizes of three guineas each and Institution Certificates have been awarded to the following competitors:—

K. E. Parish, Technician, Wembley. “Some Considerations of the Application of Television to the Cinema.”

S. L. Taylor, Technician, Southport. “Trunking and Grading (Theory and Practice).”

M. N. Denny, Technician, Carnforth. “Tricks of the U.A.X. Trade.”

K. Tiddy, S.W.II A., Truro. “Radio Communication—Radio Telephone Systems.”

Institution Certificates of Merit have been awarded to T. M. Turner, Technician, Glasgow. “Industrial Psychology.”

A. L. Deighton, Technician, Grimsby. “Radio Interference.”

J. G. Knapp, Technician, Nottingham. “The Design of a Medium Fidelity T.R.F. Receiver.”

The Judges report that the general standard of the essays was not sufficiently high to merit the award of the full number of prizes; the Council hopes that efforts will be made by the Local Centre Committees and supervising officers generally to foster greater interest in the next competition, particulars of which were given in the previous issue.

### Binding Cases

Cases for binding are available, and may be obtained from the Local Agents for 2s. Subscribers can have their copies of Volumes bound, at a cost of 7s. 6d., by sending the complete set of parts to the Local Agent or to the *P.O.E.E. Journal*, Engineer-in-Chief's Office Alder House, Aldersgate Street, London, E.C.1. Order for binding for Vols. 1-19 should indicate whether the original binding case with black lettering, or the late pattern with gold, is required. Cases with gold lettering are the only type stocked from Vol. 20 onwards.

### Back Numbers

The price of the JOURNAL, which is published quarterly is 1s. 6d. (1s. 9d. post free) per copy, or 7s. per annum post free. Back numbers can be supplied, subject to availability of stocks, at 1s. 6d. each (1s. 9d. post free). Order for back numbers may be sent to the Local Agents or to the Publishers.

### Advertisements

All communications relating to space reservation should be addressed to the Advertisement Editor, *P.O.E.E. Journal*, Alder House, Aldersgate Street London, E.C.1. Communications regarding advertisement copy, proofs, etc., should be addressed to the Publishers, Messrs. Birch & Whittington (Prop. Dorlin & Co. [Epsom], Ltd.), 49 Upper High Street, Epsom Surrey.

# MODEL ANSWERS

## TO

### CITY AND GUILDS OF LONDON INSTITUTE EXAMINATIONS

#### TELECOMMUNICATIONS (PRINCIPLES) I and TELEPHONE EXCHANGE SYSTEMS I

A limited number of these books is still available and orders should be placed at an early date to avoid disappointment.

#### TELEGRAPHY I and RADIO I

These new publications are now in stock and immediate delivery can be made.

#### TELECOMMUNICATIONS (PRINCIPLES) II and TELEPHONE EXCHANGE SYSTEMS II

Orders are invited for the further publications in this series as mentioned above, which are expected to be available by January, 1949.

Orders may be placed with the JOURNAL LOCAL AGENTS or with THE MANAGING EDITOR, POST OFFICE ELECTRICAL ENGINEERS' JOURNAL, ALDER HOUSE, ALDERSGATE STREET, LONDON, E.C.1. Books are price 2/6 each (2/9 post free).

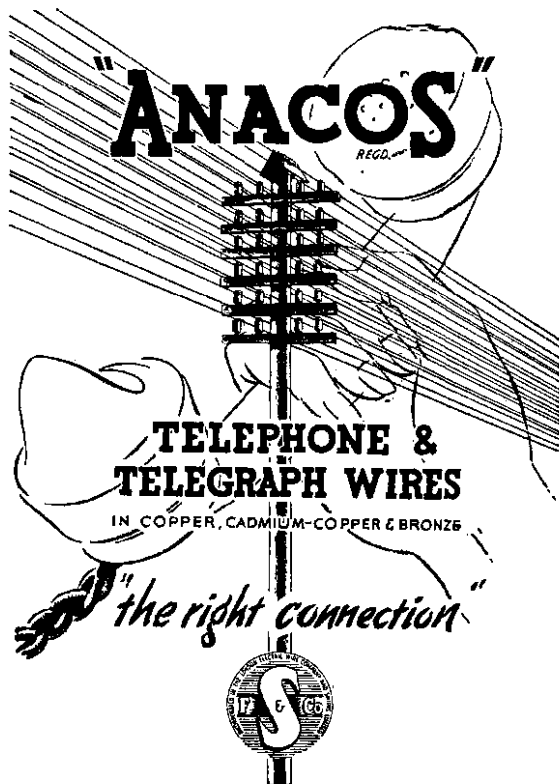

#### FREDERICK SMITH & COMPANY

(Incorporated in The London Electric Wire Company and Smiths, Limited)

ANACONDA WORKS, SALFORD 3, LANCs.

Phone: Blackfriars 8701 (9 lines) • Grams: "Anaconda," Manchester

### INDEX TO ADVERTISERS

	<i>Page</i>
Alton Battery Co., Ltd., The .. .. .	xxi
Automatic Coil Winder & Electrical Equipment Co., Ltd. ..	xxii
Automatic Telephone & Electric Co., Ltd. .. .. .	xiv, xv
Bennett College, The .. .. .	xviii
British Institute of Engineering Technology .. .. .	iv
Creed & Co., Ltd. .. .. .	ix
Edison Swan Electric Co., Ltd., The .. .. .	ii, viii
Ericsson Telephones, Ltd. .. .. .	xix
Evershed & Vignoles, Ltd. .. .. .	v
Ferranti, Ltd. .. .. .	xii
General Electric Co., Ltd., The .. .. .	ix
Great Northern Telegraph Co., Ltd., The .. .. .	xii
H. T. A., Ltd. .. .. .	xvi
International Correspondence Schools .. .. .	iv
Muirhead .. .. .	x
Neill, James, & Co., Ltd. .. .. .	xviii
Neosid, Ltd. .. .. .	x
Painton .. .. .	xxii
Parmeko, Ltd. .. .. .	xviii
Pirelli-General Cable Works, Ltd. .. .. .	xxiv
Pitman, Sir Isaac, & Sons, Ltd. .. .. .	vii
Salford Electrical Instruments, Ltd. .. .. .	ii
Savage, W. Bryan, Ltd. .. .. .	xvi
Siemens Brothers & Co., Ltd. .. .. .	vi
Smith, Frederick, & Co. .. .. .	iii
Standard Telephones and Cables, Ltd. .. .. .	xiii, xvii
Sullivan, H. W., Ltd. .. .. .	xxiv
Telephone Manufacturing Company, Ltd. .. .. .	iv
Tungstone Products, Ltd. .. .. .	xxiii
Turner, Ernest, Electrical Instruments, Ltd. .. .. .	xx
United Insulator Co., Ltd. .. .. .	xx
Westinghouse Brake & Signal Co., Ltd. .. .. .	viii
Winn & Coales, Ltd. .. .. .	vii

# CARPENTER Polarized RELAY TYPE 4

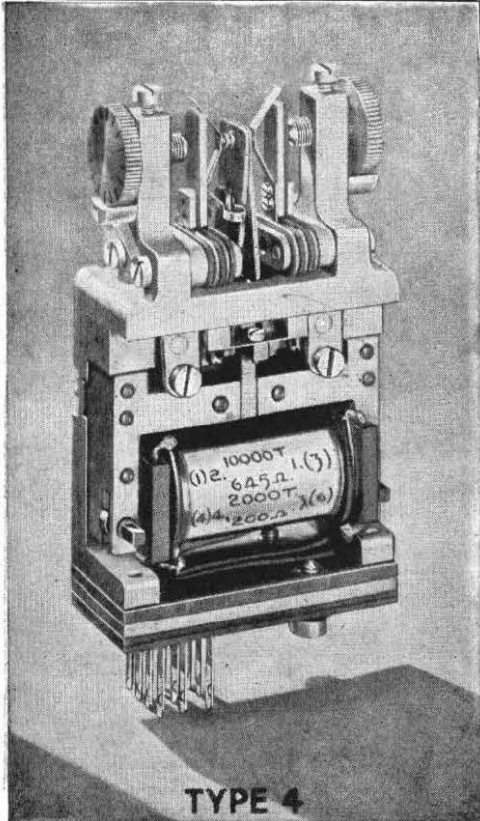

This is a medium speed, sensitive relay with long contact travel designed primarily as a telephone impulsing relay (D.C. dialling up to 100 miles and V.F. dialling on trunk circuits). It has also been successfully adopted for use in Telex systems.

Its sensitivity is such that when the gap is adjusted to .004 in. the relay will just operate at 50 cycles with 4 ampere-turns (corresponding to approximately 1 mVA) or on  $2\frac{1}{2}$  D.C. ampere-turns at low speeds. In service, however, the relay is normally operated at currents substantially larger than the minimum operating current.

Contact chatter is absent if the contact gap does not exceed .004 in. The contact gap is adjustable by means of fine pitch screws with knurled heads marked with .001 in. divisions.

Contacts on the armature tongue are insulated from it and thereby from the frame.

Terminals for soldered connections are fitted as standard.

The relay is supplied with a magnetic screening cover with transparent removable top to facilitate contact adjustment.

Dimensionally the relay is interchangeable with the type "3000" relay and can be supplied to fit directly to the drilling normally provided for the "3000" relay.

**Dimensions of the Type 4 Carpenter Relay are:— (With cover. Excluding wiring tags)**  
3 $\frac{3}{8}$  ins. high x 2 $\frac{1}{8}$  ins. wide x 1 in. deep. Weight: 13 ozs.

Manufactured by the Sole Licencees for the Eastern Hemisphere

## TELEPHONE MANUFACTURING CO. LTD.

Contractors to the British Commonwealth and Foreign Governments

HOLLINGSWORTH WORKS • DULWICH • LONDON, S.E.21

Telephone: GIPsy Hill 2211 (10 lines)

## A PRACTICAL PLAN for EARLY PROMOTION



**Valuable Free Handbook Tells You  
How to Pass Your C. & G.  
or Promotion Exam. at First Attempt!**

All Post Office Engineering personnel who are anxious to obtain early promotion should at once send for a copy of our handbook "ENGINEERING OPPORTUNITIES," which, among other intensely interesting matter, describes our unique methods of preparation for **TECHNICAL APPOINTMENTS IN THE POST OFFICE** (Assistant Engineer—New Style and Assistant Traffic Superintendent), **A.M.I.E.E., CITY AND GUILDS EXAMINATIONS** in Principles of Telecommunications (1-5), Radio (1-4), Telephone Exchange Systems (1-3), Telegraphy (1 and 2), Line Transmission (1 and 2), Lines Plant Practice (1 and 2), Mathematics for Telecommunications (1-5), Electrical Engineering Practice (Prelim. Inter. and Final), and outlines a wide range of non-examination courses in all branches of Electrical, Mechanical, Civil, Automobile, Aeronautical and Radio Engineering.

**We definitely guarantee  
"NO PASS—NO FEE"**

If you intend to make the most of to-day's opportunities, you cannot afford to miss reading "ENGINEERING OPPORTUNITIES." It tells you everything you want to know to secure advancement, and describes many opportunities you may now be missing through lack of information. Send for your copy to-day—**FREE** and without obligation.

**BRITISH INSTITUTE OF ENGINEERING TECHNOLOGY**  
369 SHAKESPEARE HOUSE, 17-19 STRATFORD PLACE, LONDON, W.1

## SOUND INSTRUCTION by Postal Method

The I.C.S., largest school in the world devoted to spare-time training by the postal method, offers you highly specialised Courses of Instruction for the following Examinations:

**P.M.G. Certificates in Wireless Telegraphy  
Associate Membership of I.E.E.**

**C. & G. Electrical Engineering Practice, Installation and Telecommunications.**

**Graduateship of the B.I.R.E.**

Other Courses meet the requirements of all who desire to qualify for responsible positions in Electric Power, Illumination, Heating and Traction Systems. Equally successful is our instruction for Telegraph Engineers, Radio Engineers and Radio Servicemen.

Instruction is by correspondence from textbooks specially prepared by many experts,

**WRITE FOR OUR SPECIAL BOOKLET** and state the particular subject or Examination in which you are interested. *I.C.S. Examination students are coached till successful.*

..... **YOU MAY USE THIS COUPON** .....

**International Correspondence Schools Ltd.**

Dept. 108, International Buildings, Kingsway, London, W.C.2

Please send me, free of charge, your special  
booklet on .....

Name .....

Age .....

Address .....





# EVERSHED RECORDERS

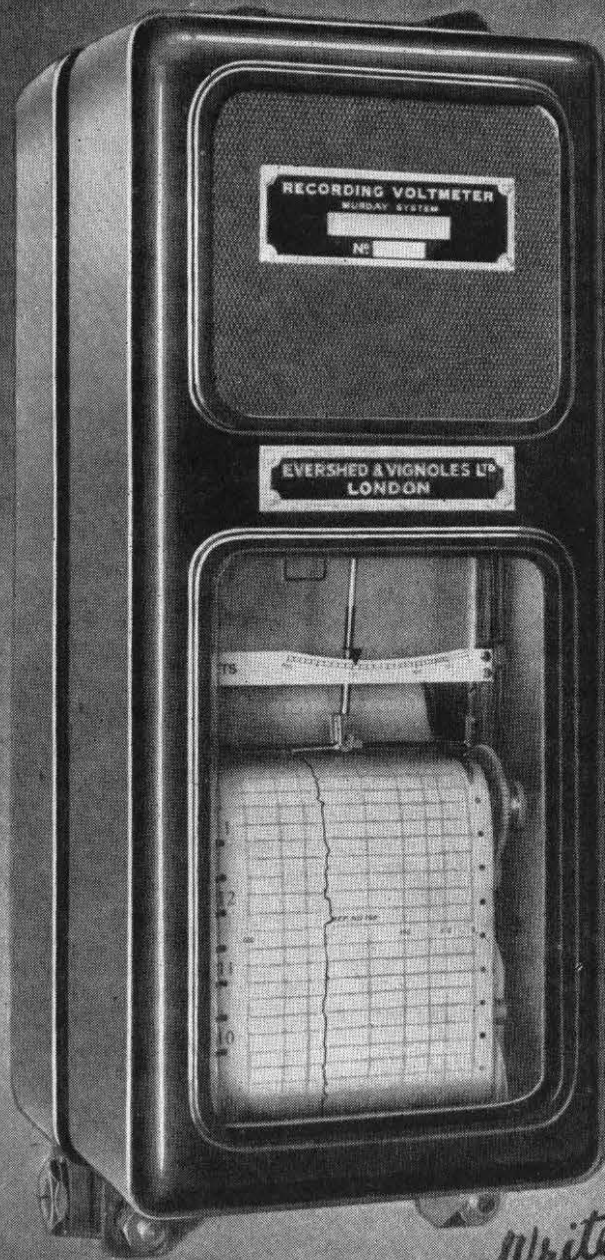

*Write for illustrated  
List number 213*

**EVERSHED & VIGNOLES, LTD.,**  
**LONDON, W.4.**

TELEPHONE: CHISWICK 1370 ★ TELEGRAMS: "MEGGER", CHISK, LONDON.

# SIEMENS

## NO. 17 SYSTEM

## DIGIT SWITCH

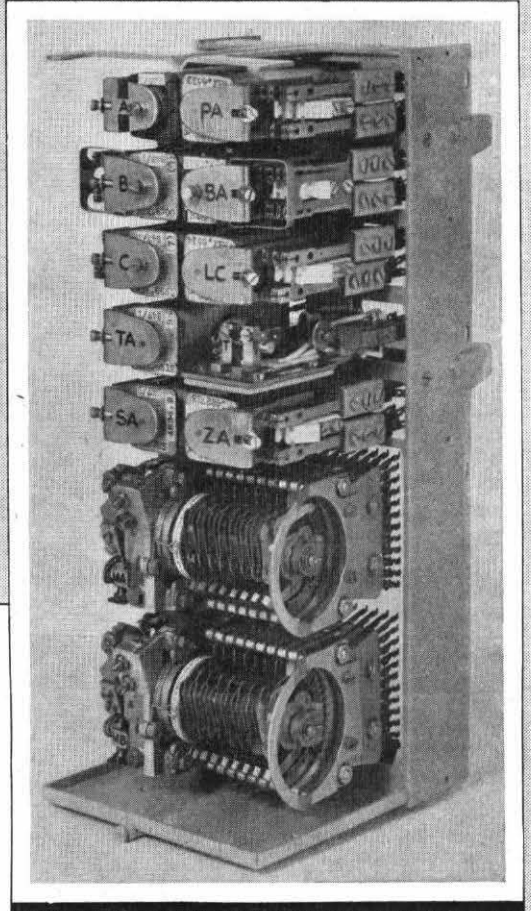
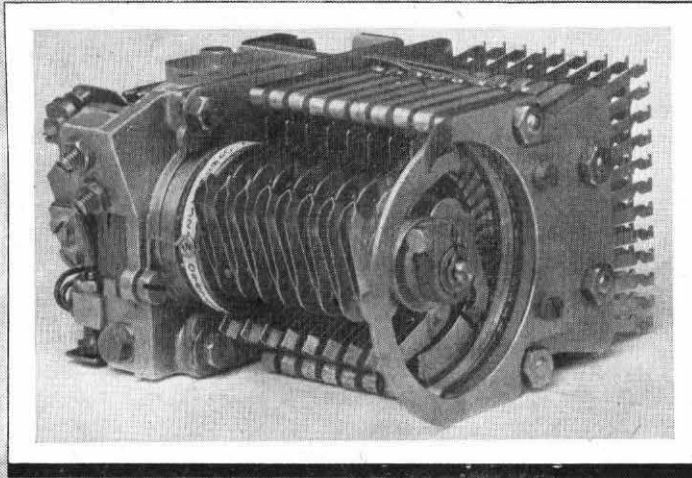

**T**HE Digit Switch records dial-impulses and marks the particular outlet group in which motor-uniselector search is to take place. It has a remarkable durability and sets a high standard of impulse-receiving performance.

All adjustments are carried out from the front of the switch. It has a reverse-drive action and there are no feeder springs between wipers. This switch has a tag field which is flat, thus enabling wiring and marking cross-connections to be done with ease.

**SIEMENS BROTHERS & CO., LIMITED**  
 WOOLWICH • LONDON • S. E. 18.

## **The MAINTENANCE ELECTRICIAN'S Handbook**

By D. J. Hartshorne. In this useful new book the author lays down practical methods of working for the maintenance electrician, and shows how to solve problems which are commonly encountered. Contains a wealth of useful data and is well illustrated.

Recently published. 8/6 net

## **STEEL FILES**

### *Their Manufacture and Application*

By Eric N. Simons. No single book has ever contained so much practical information on the history, manufacture, maintenance and the future of steel files. It explains how to select the right file for any particular work, and how it should be handled. Profusely illustrated. 15/- net

## **Pitman Books**

*Parker Street, Kingsway, London, W.C.2*

DENSO *at the service of the*  
ELECTRICAL ENGINEER

**"I** honestly find that Denso is the greatest boon and blessing to Mainsmen ever invented . . . .

. . . As a matter of National importance all Mains Engineers should be informed of the usefulness of Denso, particularly for waterproofing temporary openings during fault location, even on 11,000 volt cables."

These are two extracts taken from a letter sent to us by a District Mains Engineer. They are spontaneous and represent the opinion of a man who knows the materials to meet the job.

"DENSO"  
Regd.



PRODUCTS

IMITATED BUT NOT EQUALLED

*Write for Specification and Price List*

**WINN & COALES LTD**

TERMINAL HOUSE, GROSVENOR GARDENS, LONDON, S.W.1

Telephone: Sloane 6264    Telegrams: Denselte. Sowest. London

# **Up-to-date PITMAN BOOKS**

## **The Calculation of Fault Currents in Electrical Networks**

By R. T. Lythall, A.M.I.E.E. This is a sound introduction to the subject of circuit-breaker selection, embodying useful methods of calculation requiring the minimum of complicated theory. Second Edition. 12/6 net

## **Elementary Vectors for Electrical Engineers**

By G. W. Stubbings, B.Sc.(Lond.), F.Inst.P., A.M.I.E.E. A useful guide to the fundamental principles of vector theory for those who do not take kindly to the mathematics of electrical technology. Anyone knowing the rudiments of geometry, algebra and trigonometry can understand this book without difficulty. With graphs and diagrams. Third edition. 7/6 net

**PITMAN,** Parker Street, Kingsway, London, W.C.2

## ★ **Photoelectric Cells in Industry**

By R. C. Walker, B.Sc.(Lond.), A.M.I.Mech.E., A.M.I.E.E. A comprehensive treatise for all electrical and mechanical engineers whose work demands a knowledge of some of the industrial uses of these cells. Profusely illustrated. 517 pages.

**40/- net**

"An enormous amount of careful study on a highly technical level has gone into the compilation of this volume, which is packed with circuits, diagrams, and illustrations throughout its 500 pages."  
—British Journal of Photography.

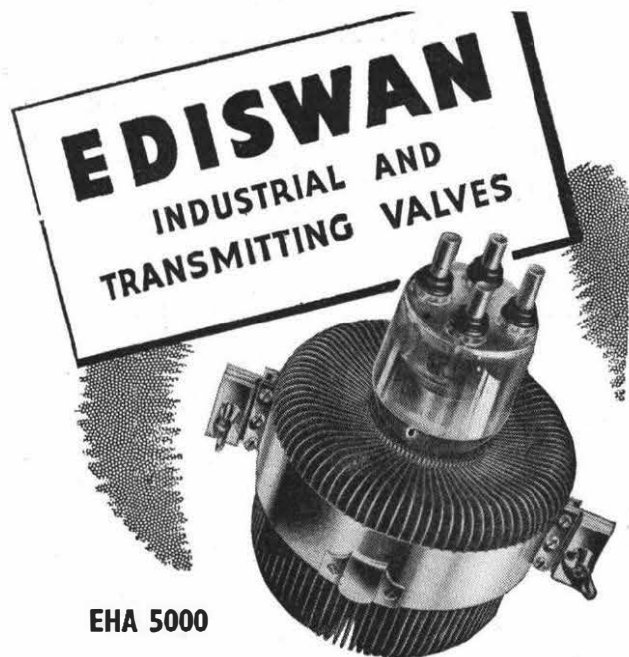

EHA 5000

The EHA 5000 is a forced air cooled triode valve for use as an R.F. Amplifier or Oscillator.

The design minimises lead inductance and makes the valve particularly suitable for H.F. applications. This valve is the direct equivalent of the American type 889R.

**RATING**

Filament Voltage	...	...	11 volts.
Filament Current	...	...	125 amperes
Maximum Anode Voltage	...	...	8.5 KV.
Maximum Anode Dissipation	...	...	5 KW.
Amplification Factor	...	...	20
Mutual Conductance	...	...	*10 MA/V.
Impedance	...	...	2,000 ohms
Maximum Operating Frequency	...	...	†25 Mc/s.
Power Output	...	...	8 KW.

\* Taken at  $V_a = 5$  KV.  $I_a = 1$  amp.

† May be operated at higher frequencies provided the maximum values of anode voltage and power input are reduced.

**INTER-ELECTRODE CAPACITANCES**

Anode-Grid	...	20.7 $\mu$ F.
Anode-Filament	...	2.5 $\mu$ F.
Grid-Filament	...	19.5 $\mu$ F.

**AIR FLOW**

500 cu. ft./min.

Further details on request

A catalogue giving details of other Ediswan Industrial and Special Purpose Valves will be supplied on request.

**EQUIVALENTS**

EDISWAN	U.S.A.
EHW 5000	889
ESA 892	892R
ESW 892	892
ESW 207	207
ES 204A	204A
ESU 400	575A
ESU 866	866/866A
68506	18049 G.E.
68510	2000 RCA
	12x825

**THE EDISON SWAN ELECTRIC CO. LTD.**  
155 Charing Cross Road, London, W.C.2.

(RM 65)

# The WESTINGHOUSE STABILISTOR

## for stabilising AC supplies

Type "A" provides an AC voltage of good waveform substantially independent of load current and/or variations in the AC supply voltage.

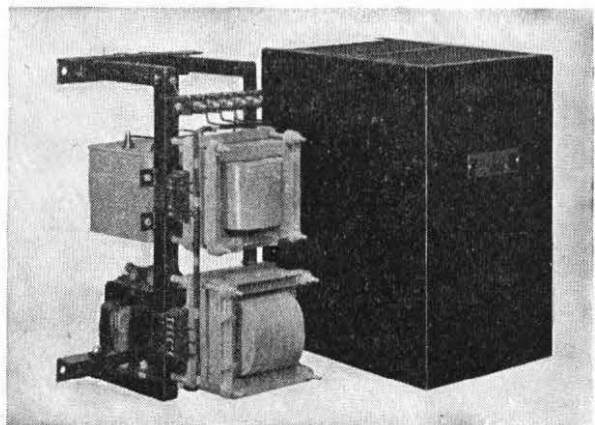

TYPE "A" STABILISTOR WITH COVER REMOVED

Type "B" (dual purpose) has two outputs, which are available alternatively, but not simultaneously. Output No. 1 is frequency and voltage-compensated. Output No. 2 is voltage and load-compensated.

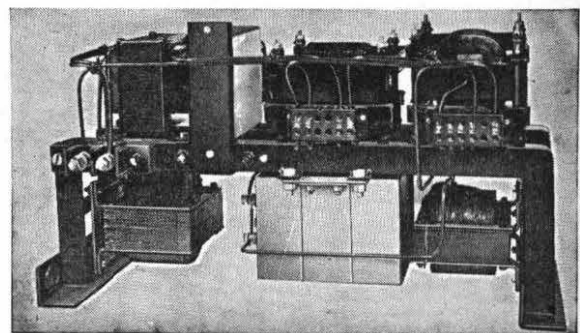

TYPE "B" STABILISTOR WITH COVER REMOVED

For full details of Types A and B write for PUBLICATION EE.2 to Det. P.O.E.E.J.10

**WESTINGHOUSE BRAKE & SIGNAL CO., LTD.**  
82 YORK WAY, KING'S CROSS, LONDON, N.1

TELEPHONE TRANSMISSION EQUIPMENT  
SUBSCRIBERS' TELEPHONES • LOADING COILS  
AUTOMATIC AND MANUAL EXCHANGES  
TRUNK AND LOCAL CABLES • OVERHEAD LINES  
TEST EQUIPMENT OF ALL KINDS

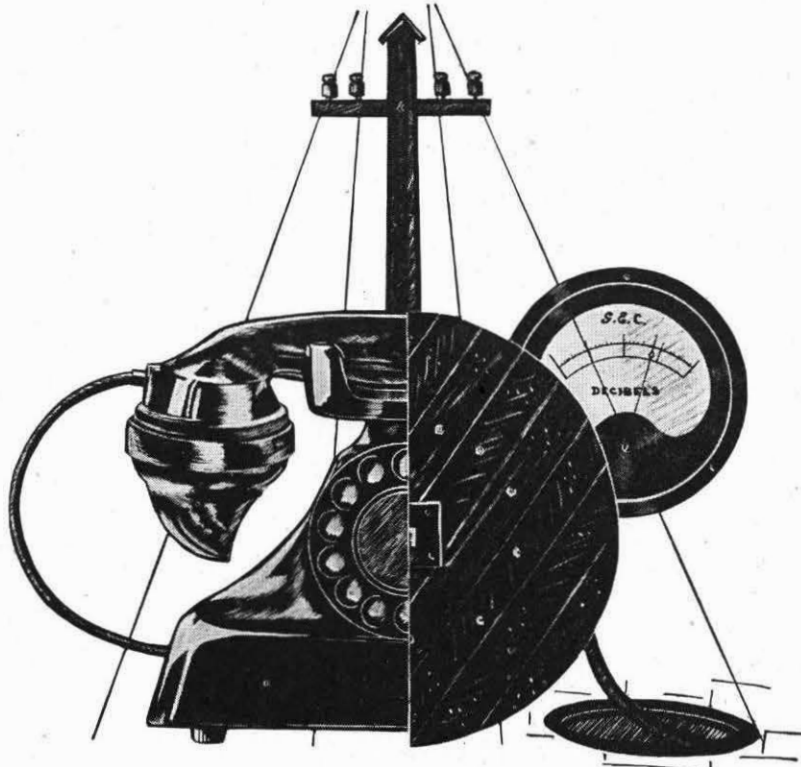

*Telecommunication  
Equipment  
by G.E.C.*

THE GENERAL ELECTRIC CO. LTD. OF ENGLAND  
HEAD OFFICE: MAGNET HOUSE, KINGSWAY, LONDON

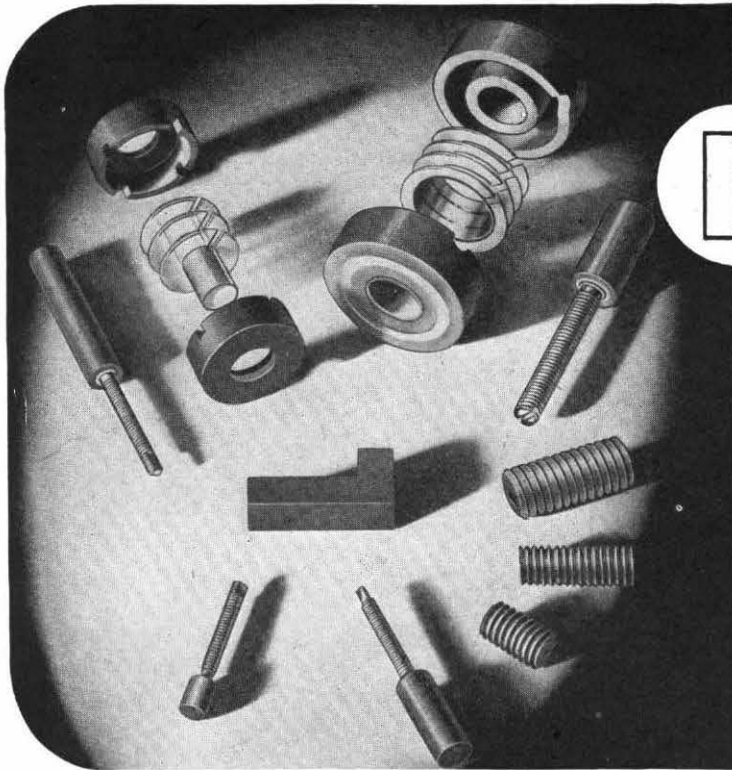

# neosid

## IRON DUST CORES

High performance : Strength : Stability  
Close electrical and mechanical tolerances  
Grades to suit various applications

**neosid** *limited*

23 and 25 Hyde Way, Welwyn  
Garden City, Herts.

Tel : Welwyn Garden 925

 P.O.J.6.



TYPE D-197-A

## MEASURE YOUR COMPONENTS

on the

## MUIRHEAD IMPEDANCE BRIDGE

*It gives answers without ambiguity*

**RANGES:** D.C. RESISTANCE: 0.001 ohm to 1.11 Megohms.

**CAPACITANCE:** 1  $\mu\text{F}$  to 100  $\mu\text{F}$ .

**DISSIPATION FACTOR:** 0-1.2.

**INDUCTANCE:** 1  $\mu\text{H}$  to 1000 H.

**MAGNIFICATION FACTOR:** 0-60.

### FEATURES: BUILT-IN

Provision for use of external generator for A.C. measurements up to 10 kc/s.

Provision for use of external galvanometer.

Mechanical interlock between dials displays only one answer.

Electronically operated Wagner earth.

All-mains operation.

Resistance and reactance standards.

1 kc/s oscillator and bridge amplifier for A.C. measurements.

Rectified A.C. source and sensitive centre-zero galvanometer for D.C. resistance measurements.

Full details in publication C-104-A — which will gladly be sent on request.

Muirhead & Co. Limited, Elmers End, Beckenham, Kent. Tel : Beckenham 0041-2

FOR OVER 60 YEARS DESIGNERS AND MAKERS OF PRECISION INSTRUMENTS

# No. 47 TAPE MODEL TELEPRINTER

FOR —

MODERN TELEGRAPHY—

A NEW PRODUCT

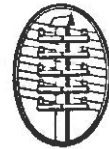

*Creed*



- Printing point is in ideal position on left side.
- Receiving cam orientation device facilitates optimum adjustment.
- Conforms to C.C.I.T. recommendations.
- Tape and ink ribbon are replenished without removing cover.
- Accessible printing unit using typewriter ink ribbon.
- Answer-back unit (20 characters).
- A cover attachment for accommodating message forms, etc., can be provided for handling heavy traffic.
- Simplified maintenance with unit construction.
- Quiet in operation.

*Creed and Company Limited*

TELEGRAPH HOUSE • CROYDON • ENGLAND

TELEGRAMS : "CREDO, TELEX, CROYDON."  
TELEPHONE : CROYDON 2121 (7 lines).

● CABLES : "CREDO, CROYDON."  
● TELEX : CROYDON, TELEX 1082

# FERRANTI

## 7-Range CLIP-ON AMMETER



### RANGES

- 0 - 10 Amps.
- 0 - 25 "
- 0 - 50 "
- 0 - 100 "
- 0 - 250 "
- 0 - 500 "
- 0 - 1000 "



Thumb-operated switch

Fully insulated

Accuracy within 3% of full scale

Can be applied to bare or insulated conductors up to 2 1/4 ins. diameter

Weight... 3 lbs.

Delivery from Stock

FERRANTI LTD., HOLLINWOOD, LANCS.

London Office: Kern House, Kingsway, W.C.2

FI 69a

## UNIVERSALLY ADOPTED

### G.N.T.Co. TRANSMITTER MODEL 112

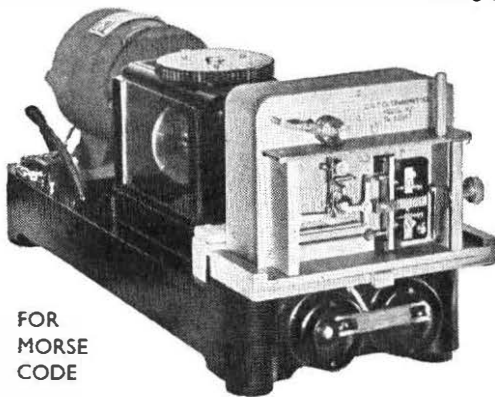

FOR MORSE CODE

13-250 words per minute without gear changes or readjustments.

Absolutely constant speed at all settings notwithstanding large voltage variations.

Noted for its easy maintenance.

Supplied with A.C. or D.C. motors as required.

**THE GREAT NORTHERN TELEGRAPH CO. LTD.**  
OF DENMARK

KONGENS NYTORV 28  
COPENHAGEN K. - DENMARK

AND

5, ST. HELEN'S PLACE,  
LONDON, E.C.3





## *SenTerCel* SELENIUM RECTIFIERS

### AUTOMATIC BATTERY CHARGING

Re.5.

POWER supplies for telephone supervisory and signalling systems are usually provided by batteries, the voltage of which must be kept within closely controlled limits if the equipment is to operate satisfactorily. Battery maintenance, therefore, is of the greatest importance.

The SenTerCel Automatic Charger maintains battery voltages within  $\pm 2\frac{1}{2}\%$  of their nominal value and needs no maintenance whatever, control being obtained from the battery voltage itself by means of vacuum tube thermal relays.

Bulletin SRT.37 gives details of the standard range and special designs can be produced to individual requirements

## *Standard Telephones and Cables Limited*

Selenium rectifiers of all types including Uniplate, tubular and spindle mounted stacks. Equipments for stationary or vehicle battery charging, electrostatic precipitation, aircraft and vehicle engine starting, electro-plating and similar electrolytic processes. Power supplies for circuit breaking and other operations.



RECTIFIER DIVISION · OAKLEIGH ROAD · NEW SOUTHGATE · LONDON · N.11

# Why do we advertise in the 'P.O.

Present circumstances, arising out of the national need, prevent us from devoting more than a fixed proportion of our output to fulfilling the demands of the home market, but as the largest manufacturers of Strowger Automatic Telephone Equipment—standardised by the British Post Office—we consider it important to keep British Post Office engineers informed as to our development and production achievements.

A second and perhaps more important reason why our announcements appear in these pages is that we know that the Journal is subscribed to by the telephone authorities of other countries and we wish to address the following appeal to their engineers:—

“If you will specify British-made Strowger equipment you will be amply repaid. Firstly, you will be assisting your own country's trade, for Britain—having sold—can buy. Secondly, you will be providing your subscribers with the most efficient telephone service and in the process be making a genuine contribution, through such efficiency, to world recovery.”

**STROWGER Telecommunications Equipment**



**AUTOMATIC**

EXPORT DEPT:—

# E.E. Journal' ?



**British-made STROWGER Main Automatic Telephone Exchanges are providing service in or are on order for ...**

Argentine  
Australia  
Bahamas  
British West Indies  
Brazil  
British East Africa  
Canada  
Egypt  
Great Britain  
Hong Kong

India  
Iraq  
Japan and Manchukuo  
Netherlands and D.W.I.  
New Zealand  
Pakistan  
Poland  
Portugal  
Portuguese East Africa  
Rhodesias

★ **75% of the World's automatic telephone subscribers use STROWGER equipment**

South West Africa  
Sudan  
Union of South Africa  
U.S.S.R.  
Venezuela

*... and similar equipment is installed in many other countries*

## TELEPHONE & ELECTRIC CO. LTD.

NORFOLK HOUSE, NORFOLK STREET, LONDON, W. C. 2  
Cables: Autelco, London  
STROWGER WORKS LIVERPOOL 7 ENGLAND

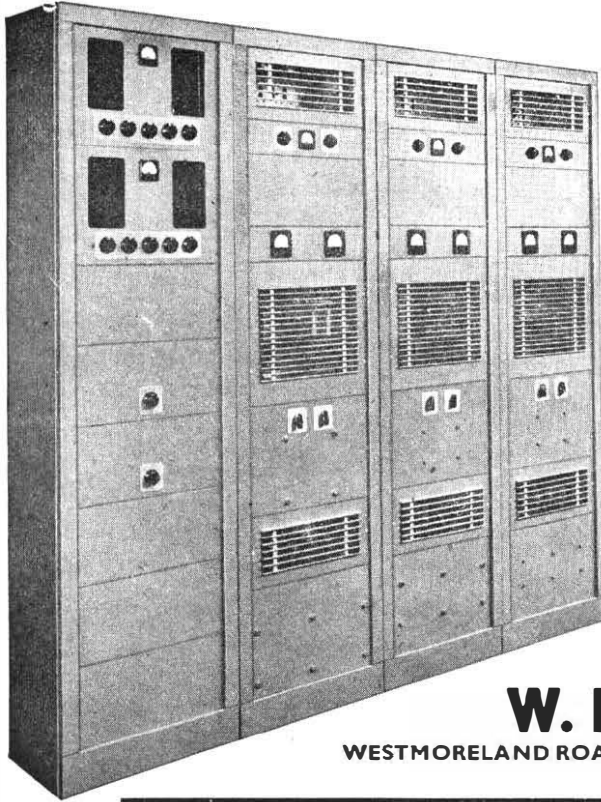

*The Mark II series of*  
**SAVAGE AMPLIFIERS**  
*for Broadcast Relay*

● These Amplifiers are examples of what careful design can achieve. A lift-off back panel affords immediate access for maintenance purposes and the removal of six screws releases the side covers of the rack and exposes all the interpanel wiring. Even when the rack is sandwiched between others the side covers can be moved just as easily. All valves are accessible from the front of the rack, and are protected by quick release grilles. The rack is completely flat fronted. The general appearance is further enhanced by the absence of a projecting front foot, and the marking of all panel fixing bolts. Similar racks carrying auxiliary apparatus can be placed side by side with amplifiers so that the whole installation is uniform in appearance. Complete specifications available on request.

**W. BRYAN SAVAGE LIMITED**

WESTMORELAND ROAD · LONDON N.W.9 · TELEPHONE: COLINDALE 7131

*A Typical Example of*  
**H.T.A. DESIGN**

Included in the range of H.T.A. Products are Telephone Coin Collectors, Stamp Selling Machines, Autodials, Commodity Vending Machines, Coin Operated Mechanisms, Kitchen Control Units, Gas Leak Indicators, Ticket Printing and Issuing Machines also Stamp Emitters of which a model is illustrated here.



This New H.T.A. Stamp Emitter is invaluable for issuing, under controlled conditions, in Post Offices and Commercial Undertakings, postage, insurance and other perforated adhesive stamps from a roll. One or any number of stamps can be issued very rapidly and the quantity is automatically recorded on a check counter. It is designed so that it can be used on a desk or for more permanent installation it can be let into the desk or counter so that the top surface of the unit is flush.

**HALL TELEPHONE ACCESSORIES LTD.**

*Precision Engineers & Instrument Makers*

DUDDEN HILL LANE · WILLESDEN · LONDON · N.W. 10

PHONE WILLESDEN 5141

TL.4



# TELEVISION CABLES

THIS 4-core, Type 375DS coaxial cable will provide on two of the cores 960 "4-wire" speech channels and the other two cores will carry a two-way television channel with a band width of 4 mc/s. In addition up to 196-20 lb. star quads plus some screened "music" pairs or quads may be supplied for toll circuit application.

Technical details on this and on other similar cables in the *Standard* range will be provided on request.

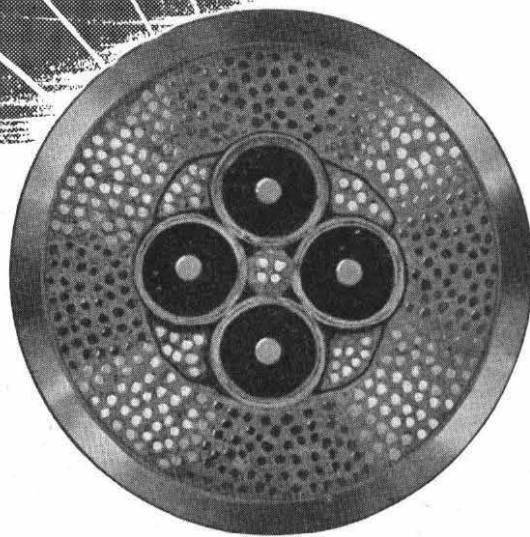

## COAXIAL CABLES

by

*Standard Telephones and Cables Limited*

NORTH WOOLWICH, LONDON, E.16 Telephone: Albert Dock 1401



**Eclipse** PERMANENT MAGNETS

IN  
**TUNGSTEN · CHROME  
COBALT · ALNI · ALNICO  
& ALCOMAX**

Our Technical Development Section will be pleased to advise on any problem connected with applied magnetism

Made by the manufacturers of  
"ECLIPSE"  
PERMANENT MAGNET CHUCKS

EM 7  
**JAMES NEILL & CO. (Sheffield) LTD., SHEFFIELD, ENGLAND**

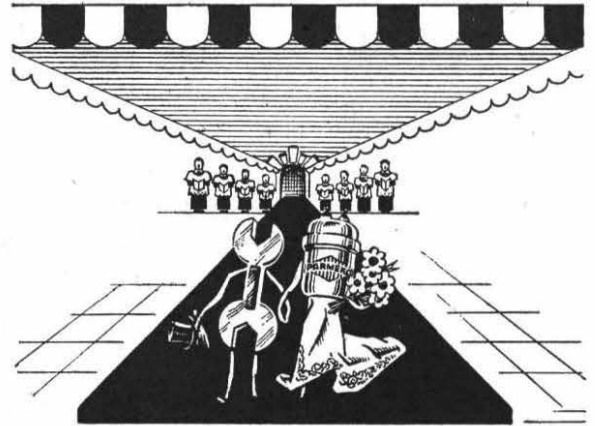

AT THE WEDDING OF  
PARMEKO TO INDUSTRY . . .  
This happy day is the culmination of many troubles - as schoolboy and girl they hated each other like poison. As they grew into the teenage they took more notice of one another - flirted a little and then fell out. Grew up a little more and their feelings developed with purpose and they were constantly seen about together.

When times of trouble and war came they plighted their troth and resolved to work together hand in hand.

This has now developed further into a sense of mutual trust and respect where each recognises the other as a partner, where . . . Oh, let's stop talking in riddles. Just think of us at Parmeko as a wife and partner in your Transformer troubles, we are there to help in times of difficulty. Use us and don't worry . . . let's live happily ever after.



★ Makers of Transformers for the Electronic, Signal, Luminous Tube, Oil Ignition Industries, etc. Ⓞ

STUDY  
AT  
HOME

You Can Have a College Training  
For a Few Shillings Monthly

IN YOUR  
SPARE  
TIME

FOUNDED 1900                      40 YEARS OF SUCCESS

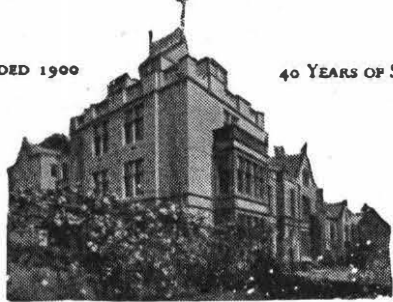

**CITY and GUILDS (Telecommunication) EXAMINATIONS**

To every student we send a written Guarantee of Tuition until the examination is actually passed

Our tuition is so graded that each stage is reached without difficulty.

Personal attention is given to every student.

FULL PARTICULARS AND ADVICE SUPPLIED FREE.

WE TEACH BY POST IN ALL PARTS OF THE WORLD

*The most progressive and most successful  
Correspondence College in the world*



Dept. 24, THE BENNETT COLLEGE SHEFFIELD

# LOUD RINGERS . . . .

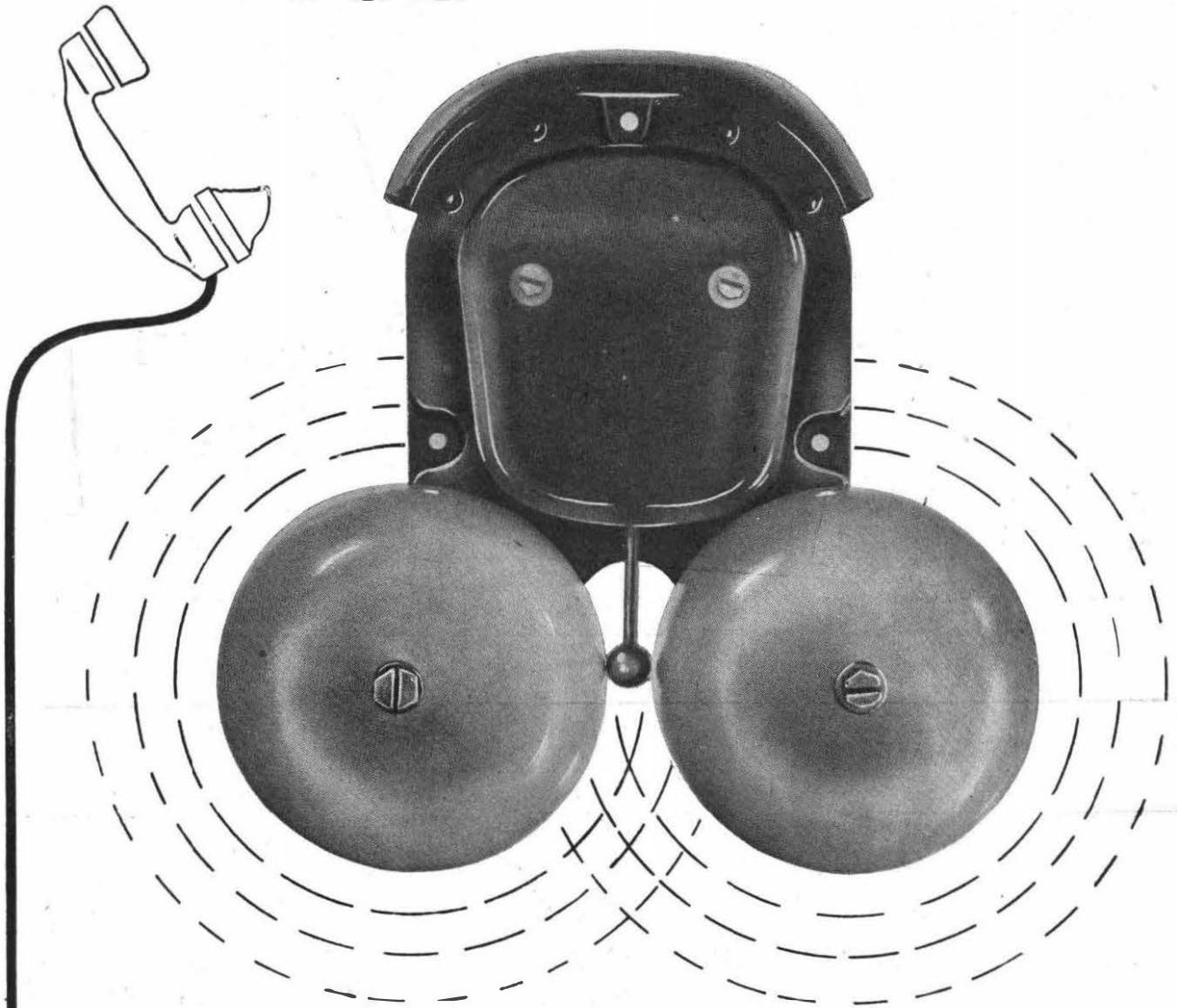

The Ericsson N 3111 Magneto Extension Bell shown here is British Post Office Standard. All metal case. 6" gongs and weighs 8 lbs. Strong clear sustained ring. Moisture proof. Ideal for Factories, Railway Yards, Warehouses, etc. Models supplied certified safe for use in Petroleum and Acetone Vapours.

# *Ericsson*

## MAGNETO EXTENSION BELLS

ERICSSON TELEPHONES LTD. · Head Office: 22 LINCOLN'S INN FIELDS, LONDON, W.C.2. · Tel.: HOL 6936  
Works: BEESTON, NOTTS.

**NEW DESIGNS**  
 in the range of  
**U.I.C**  
*High Stability*  
**CAPACITORS**

**2**

**U.I.C. SILVERED N**

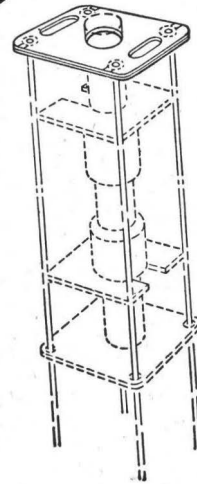

←  
 Type SMS.  
 suitable for mir  
 I.F. transform  
 square.

Type SMS  
 suitable for st  
 I.F. transform  
 square.

This new  
 Capacitor  
 been specifi  
 for use as  
 base on l.  
 part of the  
 to the coil  
 materials  
 capacitor  
 eddy curr  
 evitable  
 to suit ir

**UNITED INSULATOR CO. LTD. OAKCROFT RD.**  
 Telephone : Elmbridge 5241 (6 lines) Telegr

**ELECTRICAL MEASURING**







A16

## FARM OF THE FUTURE

*'Gad, Braithwaite, this would have shaken your old father, eh? Turning night into day . . .'*

*'Turning loss into profit, Colonel. I'll have saved the whole of my wheat, if the rain holds off till dawn.'*

When present electrification plans mature, and heat and light and power flow out to the four corners of Britain, this old country of ours will stir with a new life. No battles lost, on the farming front, that power and light can win. No winter-long household drudgery in the half-dark of lamplit, wood-fired kitchens. Better days will come for all of us. Busier days than ever, here in Alton, where we make the batteries for power stations all over the world. Hydro-Electric, Atomic or what you will, the new power stations will all need batteries. Good batteries. The kind we have always made at Alton.

# ALTON

## BATTERIES OF MERIT

THE ALTON BATTERY COMPANY LTD · ALTON · HANTS

*Sole Suppliers of Fuller Stationary Batteries*

Phone: ALTON 2267 & 2268 · Grams: 'BATTERY, ALTON'



PRICE  
**£19: 10s.**

## The H.R. AVOMETER

THIS recently developed High Resistance Avometer has a sensitivity of 20,000 ohms per volt on the D.C. voltage ranges and 1,000 ohms per volt on the A.C. ranges.

It is a compact and portable multi-range instrument having many advantages which will commend it for use in laboratory or workshop. A 5-inch clearly marked scale with an anti-parallax mirror is used for the following ranges of readings:—

D.C. CURRENT:  $50\mu\text{A}$  to 1,000 mA. A.C. VOLTAGE: 10v. to 2,500v.  
D.C. VOLTAGE: 2.5v. to 2,500v. RESISTANCE: 0.1 ohm to 5 megohms.  
(with internal battery).

The instrument can be supplied, if required, fitted with magnetic screening for protection against stray magnetic fields. It will stand up to heavy overload and is protected by an automatic cut-out.

In addition to its multi-range facilities, it can be used as a Galvanometer, for which purpose the zero can be offset to the extent of 30 per cent. of full scale deflection by a simple knob adjustment.

Size:  $8" \times 7\frac{3}{8}" \times 4\frac{1}{2}"$ . Weight:  $7\frac{1}{2}$  lbs.

Sole Proprietors and Manufacturers

**The AUTOMATIC COIL WINDER & ELECTRICAL EQUIPMENT CO. LTD**  
WINDER HOUSE • DOUGLAS STREET • LONDON • S.W.1 Telephone: VICTORIA 3404/5

HR.1



*Miniature*  
RESISTORS **PAINTON**

Wherever the engineers of electronics are gathered together, and the subject of miniature resistors crops up, the air is certain to be thick with phrases such as "No Voltage limitation," "Full-rated wattage over the complete range," "No side protuberances," "Axial Copper Leads," "Quality construction and proved reliability," and there is sure to be someone in the know who will sum up neatly by saying: "Precisely, Painton's."

Painton's miniature resistors, of course, have no voltage limitation and will withstand full-rated wattage over the complete resistance range; also they have axial copper leads without side protuberances. In fact, they have all the best features—including Quick Delivery.

PAINTON & CO. LTD.  
KINGSTHORPE • NORTHAMPTON

# POWER BEHIND THE LINES

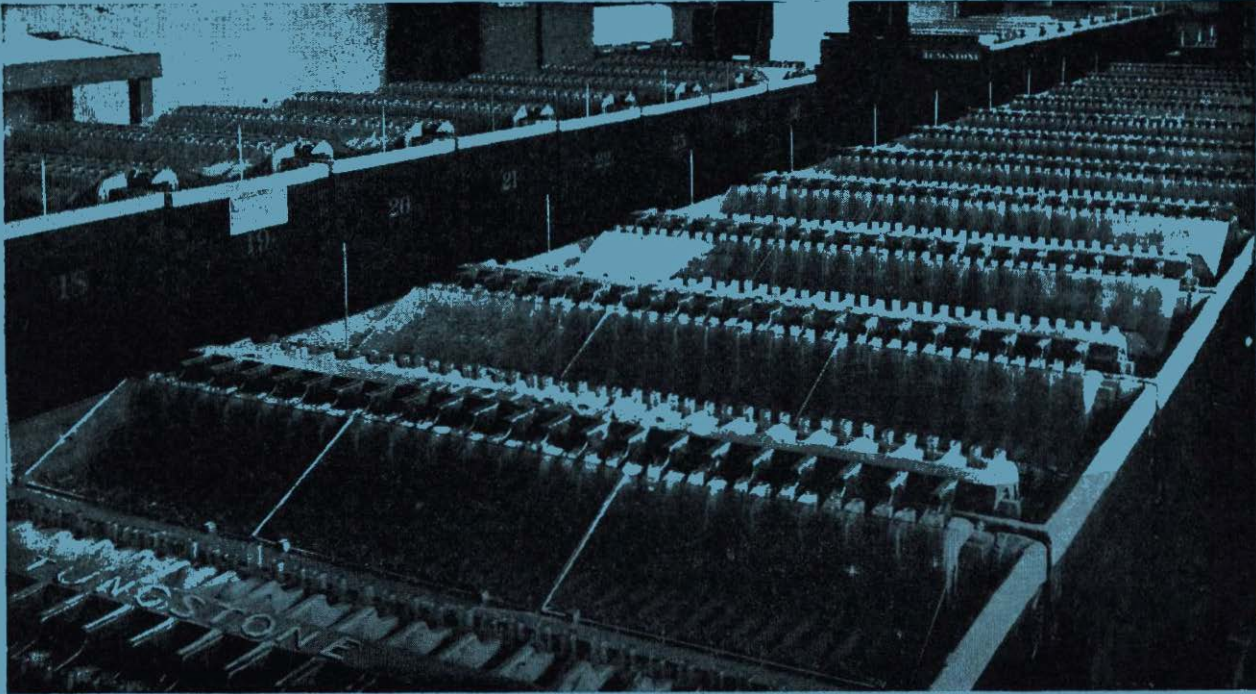

Tungstone Planté cells are being supplied to the British Post Office and to Posts and Telegraph departments abroad and conform fully to *G.P.O.* and *British Standard* specifications. Delivery is reasonable on all types and sizes.

#### *Open type cells*

Similar to the illustration above, these are available in glass and/or lead-lined wooden boxes, in capacities from 100 a.h. to 5000 a.h.

#### *Replatais*

We are in a position to supply plates for the replating of any size of existing Planté batteries.

#### *Overseas Enquiries*

Export customers are invited to cable or write their enquiries for batteries or parts. Visitors to London are welcome at our offices.

#### *Enclosed cells*

Illustrated on the right, these are in sealed glass boxes, in capacities from 10 a.h. to 200 a.h., delivered in the U.K. filled and charged.

#### *Technical Service*

We are glad to advise on most suitable types and layouts for any installation and for any purpose.

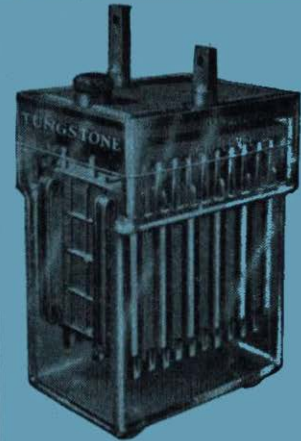

ENCLOSED TYPE CELL

# TUNGSTONE *Batteries*

For further particulars write: **TUNGSTONE PRODUCTS LIMITED,**

St. Bride's House, Salisbury Square, London, E.C.4. Telephone: CENTral 8156 (4 lines.).

Cables: DILUTUM, London Works: Market Harborough, Leicestershire.

# TELEPHONE CABLES

OUR LATEST BROCHURE No. 9E (1947)  
IS NOW AVAILABLE, GIVING INFOR-  
MATION AND SPECIFICATIONS FOR A  
WIDE RANGE OF TELECOMMUNICA-  
TION CABLES MANUFACTURED BY US.  
COPIES WILL BE SENT ON REQUEST.

TELEPHONE:  
SOUTHAMPTON  
2141 (5 lines).

**PIRELLI-GENERAL**  
CABLE WORKS, Ltd., SOUTHAMPTON.

TELEGRAMS  
"PIGEKAYBEL"  
SOUTHAMPTON.

SULLIVAN-GRIFFITHS  
TEMPERATURE COMPENSATOR  
(Patented)  
for  
CONDENSERS, OSCILLATORS, FILTERS  
AND RESONANT CIRCUITS

**Electrical Standards for  
Research and Industry  
Testing and Measuring Apparatus  
FOR COMMUNICATION  
ENGINEERING**

Continuously adjustable degree of compensation of either algebraic sign in a single compact unit without appreciable augmentation of capacitance or losses.

Action perfectly cyclic to within measurable accuracy and perfectly linear over a wide range of temperature.

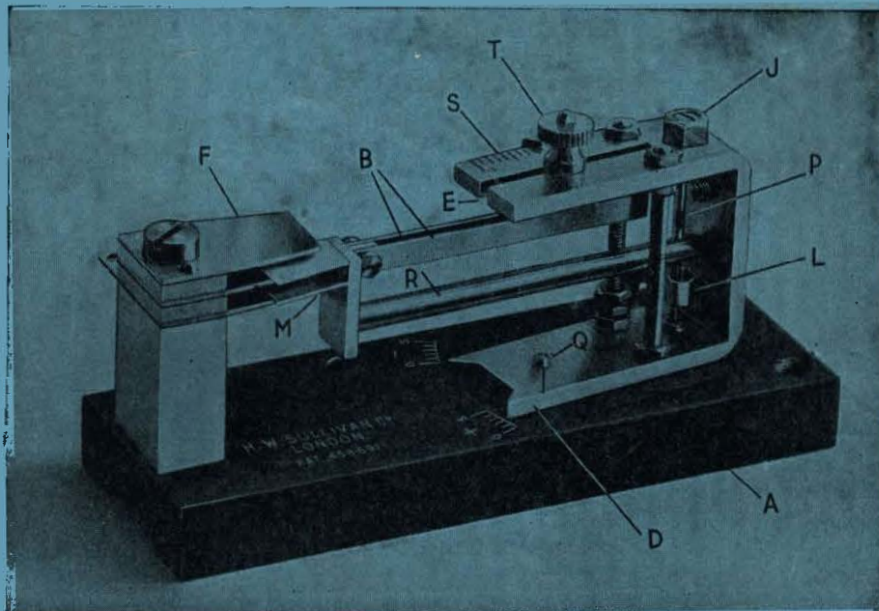

Equally free from losses at all frequencies.

Measures only  $3\frac{1}{2}'' \times 1\frac{1}{8}'' \times 1\frac{1}{8}''$ . Weighs only  $1\frac{1}{2}$  ozs. and may readily be fixed to any existing apparatus.

Special designs and quotations for quantities.

H. W. SULLIVAN LTD., LONDON, S.E.15 - Phone : New Cross 3225 (P.B.X.)