

# THE POST OFFICE ELECTRICAL ENGINEERS' JOURNAL

**VOL. 39**

**APRIL, 1946**

**PART 1**

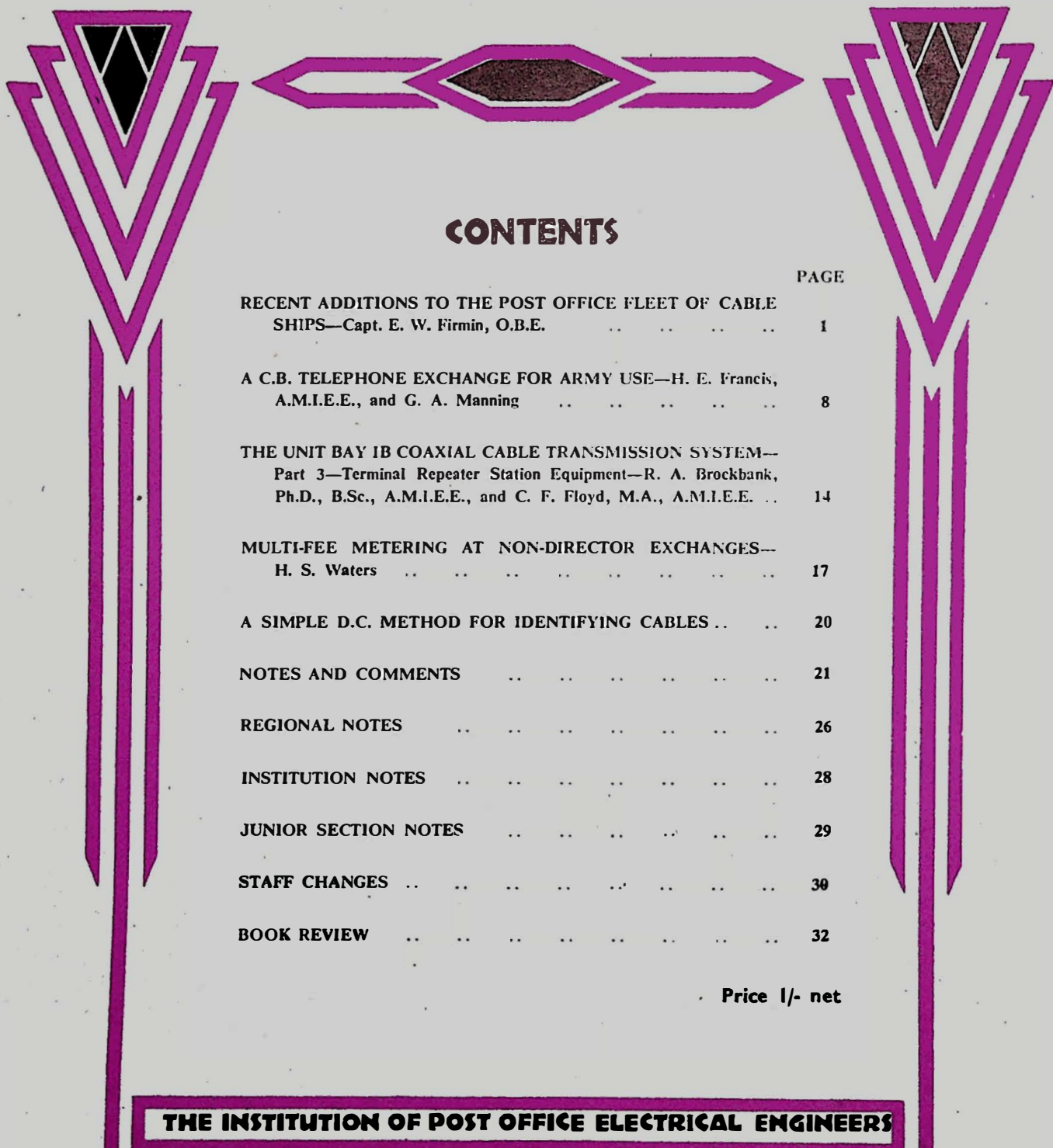

## CONTENTS

	PAGE
RECENT ADDITIONS TO THE POST OFFICE FLEET OF CABLE SHIPS—Capt. E. W. Firmin, O.B.E. . . . .	1
A C.B. TELEPHONE EXCHANGE FOR ARMY USE—H. E. Francis, A.M.I.E.E., and G. A. Manning . . . . .	8
THE UNIT BAY IB COAXIAL CABLE TRANSMISSION SYSTEM—Part 3—Terminal Repeater Station Equipment—R. A. Brockbank, Ph.D., B.Sc., A.M.I.E.E., and C. F. Floyd, M.A., A.M.I.E.E. . .	14
MULTI-FEE METERING AT NON-DIRECTOR EXCHANGES—H. S. Waters . . . . .	17
A SIMPLE D.C. METHOD FOR IDENTIFYING CABLES . . . . .	20
NOTES AND COMMENTS . . . . .	21
REGIONAL NOTES . . . . .	26
INSTITUTION NOTES . . . . .	28
JUNIOR SECTION NOTES . . . . .	29
STAFF CHANGES . . . . .	30
BOOK REVIEW . . . . .	32

Price 1/- net

**THE INSTITUTION OF POST OFFICE ELECTRICAL ENGINEERS**

# QUARTZ PLATES

*Standard Crystals cover 3-5/10 Mc/s. — but can be supplied for other frequencies and for a wide range of frequency-temperature characteristics.*

*Made in hundreds of thousands per annum for the services all over the world.*

*Made by*

**SALFORD ELECTRICAL INSTRUMENTS LTD.**

PEEL WORKS, SALFORD, 3.

Proprietors: **THE GENERAL ELECTRIC Co. Ltd., of England**



*for  
Communication  
Equipment*

# EDISWAN

## TELEPHONE LINE PROTECTOR PANELS

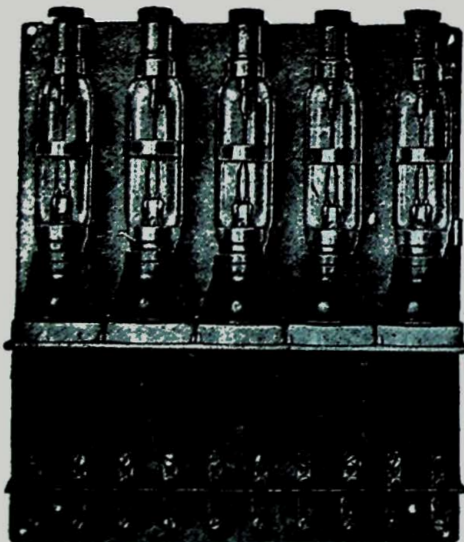

5-circuit panel for overhead lines incorporating choke coils, spark gaps, etc.

EDISWAN-SHOTTER-GREETHAM PATENT

(British Patent No. 353924)

**for the protection of telephone systems against surges induced by faults on neighbouring power lines**

Of the difficulties attendant upon the employment of overhead systems one of the most serious is to ensure uninterrupted working of the telephone system, by providing adequate protection against induced surges caused by switching or line faults in adjacent power lines or by lightning.

The Ediswan Patent Protectors provide the solution. They are inert at the normal working pressure of the telephone line, they keep the voltage on the line down to a pre-determined figure by providing a path of low resistance to earth whereby the surge is cleared and they again become inert immediately the surge is cleared.

They ensure simultaneous discharge of both lines and are capable of clearing heavy discharges without detriment to the system or the protector.

**Ediswan Telephone Line Protectors have now been in use by Supply Companies for many years.**

THE EDISON SWAN ELECTRIC CO. LTD., 155 CHARING CROSS ROAD, LONDON, W.C.2

# THE POST OFFICE ELECTRICAL ENGINEERS' JOURNAL

Vol. XXXIX

April, 1946

Part I

## Recent Additions to the Post Office Fleet of Cable Ships

U.D.C. 621.315.284 : 629.123.24

A description is given of two of the latest additions to the Post Office fleet of cable ships, H.M.T.S. *Ariel* and *Iris*. These ships each have a gross tonnage of 1,478, a service speed of 12 knots and a cable tank capacity of 16,000 cubic feet, sufficient to hold about 73 nautical miles of standard concentric submarine cable.

### Introduction.

**D**URING the war in Europe, two cable ships, H.M. Telegraph Ships *Ariel* and *Iris* were added to the fleet of Post Office cable ships. Both ships are identical in their main essentials and general appearance. They were built by Messrs. Swan, Hunter and Wigham Richardson, Limited, at their Neptune Works, Walker, Newcastle-on-Tyne, *Ariel* in 1939 and *Iris* in 1940.

The ships were built under the special survey, and to the requirements of Lloyd's Register of Shipping for their Class  $\star$  100.A1. "with freeboard."

The principal particulars are as follows:

Length overall .. ..	250 ft. 6 in.
Length between perpendiculars .. ..	228 ft. 9 in.

Moulded breadth .. ..	35 ft.
Moulded depth .. ..	24 ft. 4 in.
Gross tonnage .. ..	1,478
Net registered tonnage .. ..	486
Deadweight tonnage (includes cable, fuel, fresh water, stores, crew, etc.)	1,152 tons
Displacement: light ship	1,290 tons
Displacement: loaded .. ..	2,442 tons
Draft, loaded .. ..	16 ft. 4 in.
Twin triple expansion steam engines .. ..	1,400 I.H.P.
Service speed .. ..	12 knots
Cable tank coiling capacities	
No. 1 .. ..	4,990 cubic feet
No. 2 .. ..	5,630 cubic feet
No. 3 .. ..	5,490 cubic feet

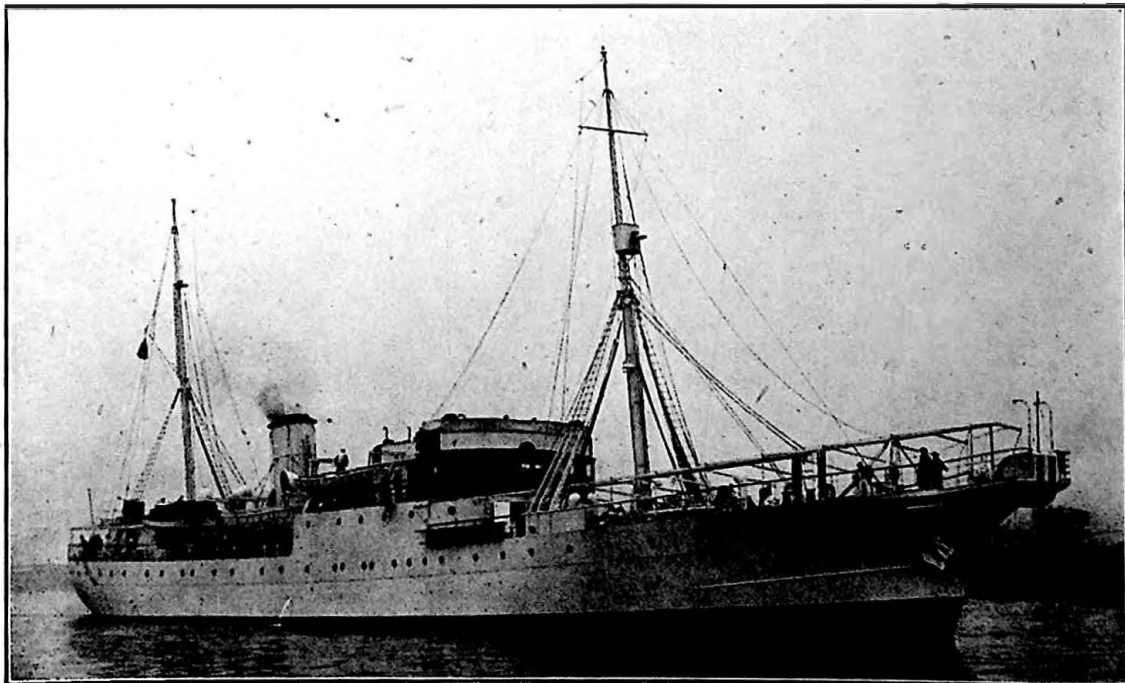

FIG. 1.—H.M. TELEGRAPH SHIP "ARIEL."

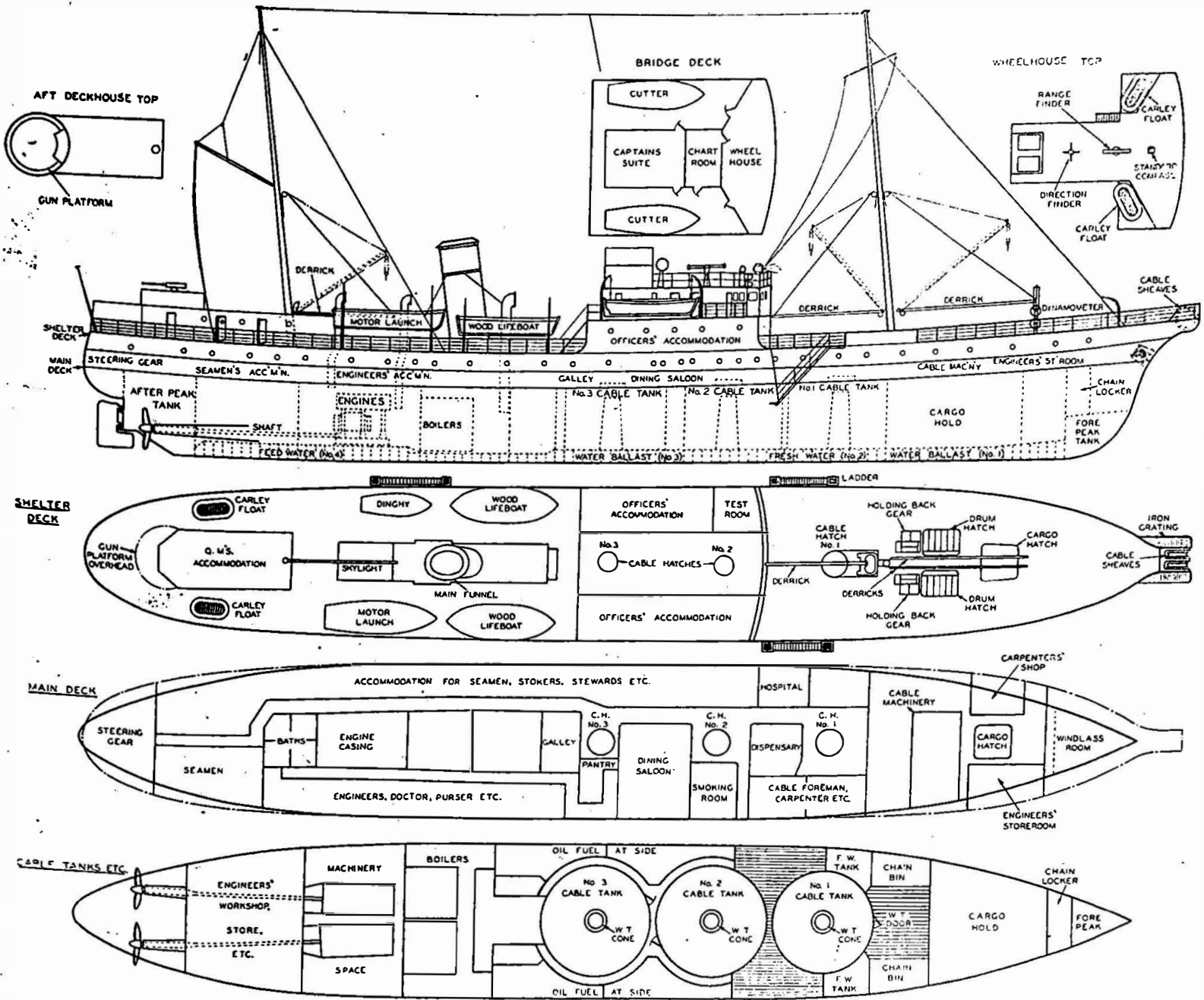

FIG. 2.—H.M.T.S. "Iris." GENERAL ARRANGEMENT (SCALE 1/32 IN. = 1' FT.).

Oil fuel capacity .. ..	248 tons
Domestic fresh water capacity .. ..	85 tons
Boiler feed water capacity	90 tons
Water ballast capacity ..	184 tons
Galley coal .. ..	10 tons

Each ship has an overhanging bow (Fig. 1) adapted for carrying two cable sheaves; a cruiser stern of normal design and semi-balanced double plate rudder of extra large surface for quick manœuvring. Stockless anchors and chain cables are provided one grade heavier than classification.

#### *Water Fuel and Cable Tanks.*

A cellular double bottom extends between the fore peak and after peak bulkheads (Fig. 2) except under the boilers, where open floors are fitted. The double bottom is divided into four water tanks, No. 1 tank being the only tank not having a centre-line watertight division. Nos. 1 and 3 double bottom tanks are fitted for water ballast, No. 2 double bottom tank for domestic fresh water and No. 4 double bottom tank for boiler feed water. The fore peak tank is used for domestic fresh water and the after peak tank is fitted for water ballast, reserve boiler feed water or reserve domestic fresh water. Deep tanks are also fitted between the forward cable tank and the ship's side for domestic fresh water and oil fuel is carried in two side bunkers on each side of the after cable tanks.

There are three cable tanks: No. 1 being 23 ft. in diameter and 15 ft. deep, Nos. 2 and 3 cable tanks are each 25 ft. in diameter by 14 ft. deep. The tanks are of welded construction and present a flat surface on the inside of the tank. The cable tanks are mounted on and welded to the double bottom tanks and are fitted with pump suction. A watertight cone is fitted in the centre of each cable tank.

Hinged watertight doors are fitted in the upper part of each tank. The door in No. 1 tank opens into the forehold and the doors in Nos. 2 and 3 tanks open into a cofferdam between these tanks. A crinoline for controlling the cable during paying out operations is fitted in each cable tank.

The hatchways are circular and over the centre of each tank. The main deck hatchways are 6 ft. in diameter and are fitted with a portable thwartships beam incorporating a bellmouth fairlead for use while laying cable. The shelter deck hatchways are 4 ft. 6 in. in diameter and are fitted with sockets to take portable spectacle leads.

The maximum cable carrying capacity represents a weight of about 700 tons or about 73 nautical miles of the Post Office standard concentric submarine cable.

Forward of No. 1 cable tank is a hold space for cable buoys, grapnels, mushroom anchors and stores, with a chain bin port and starboard on the lower (spar) deck for stowage or working chain. The hatchway is in the fore part of the hold and is served by two 2-ton derricks on the fore side of the foremast.

#### *Deck Equipment.*

All decks are of steel. The bridge deck, shelter deck and deck house tops are sheathed with teak where exposed. The living accommodation on shelter, bridge, and main decks is sheathed with Oregon pine excepting in accommodation on the main deck over the oil fuel bunkers, where the deck plating is covered with composition decking. The dining saloon and smokeroom decks are laid with hardwood parquet flooring. All exposed doors on the shelter and bridge decks are of teak. Teak storm rails are fitted at the sides of the deck houses on the shelter and bridge decks.

The boats are of specially strong construction and are fitted with Mill's patent disengaging gear and were manufactured by Messrs. Thornycroft and include:—

- One 25 ft. general service launch powered by a Thornycroft petrol engine.
- Two 22 ft. cable cutters.
- Two 25 ft. lifeboats, fitted for cable work.
- One 16 ft. sailing and pulling dinghy.

The dinghy is stowed under radial davits and the other boats are stowed under patent davits. Four Carley floats are provided as emergency life-saving appliances. An outfit of specially fitted bearers and planks, etc., is carried for constructing a raft in conjunction with the two lifeboats for laying shore ends of cables.

The two pole masts are of steel and are 74 ft. high above the shelter deck. The foremast is fitted with a Gibbins patent electric signalling lamp on the truck and two 500 W floodlights for lighting the foredeck. There are three 2-ton steel tube derricks on the foremast, two being on the foreside and serve the forehold and main working part of the foredeck, with the third derrick stepped on the after side of the foremast. A further 2-ton steel tube derrick is fitted to the fore side of the main mast for handling raft gear and any emergency lifts which have to be made for the engine room.

Cable buoy skids of timber shod with cope iron are fitted in the foremast shrouds, port and starboard, together with the necessary tackles and shiphooks for handling cable buoys.

#### *Accommodation for the Crew.*

To accommodate a large crew in a small ship always presents a problem and in this instance it has been possible to provide a reasonable standard of accommodation for a crew of 65 officers and men in peace time, which during the war has been increased to a total complement of 72 officers and men.

The public rooms in the officers' quarters are comfortably furnished, the dining saloon (Fig. 3) on the starboard side of the main deck is very commodious. The smoke room leads off from the forward end of the saloon and a small messroom for the use of duty engineer officers is provided adjacent to the saloon.

At the after end of the saloon is a fully equipped officers' pantry and a galley provided with a coal fired cooking range by the Carron Company, and also



FIG. 3.—H.M.T.S. "IRIS." OFFICERS' DINING SALOON.

a bread oven. A steam-heated boiler is fitted to provide a hot water supply.

The captain's suite is on the bridge deck abaft the chartroom and comprises a day room, bedroom and bathroom, and is comfortably furnished in accordance with modern practice. The officers' cabins, though small, are comfortably furnished and are situated on the shelter deck and the starboard side of the main deck. Petty officers' cabins are fitted as two-berth rooms with the exception of the cable foreman's cabin, which is fitted on the same plan as a junior officer's cabin. The crew's cabins are fitted as two-, three- and four-berth rooms.

Separate mess rooms are provided for petty officers, quartermasters, seamen cable hands, stokers and stewards. A well-fitted-out dispensary and hospital with two cots are provided. Ample bathroom and lavatory accommodation is provided for officers and ratings with salt water supply to baths through steam and water mixers. All officers' cabins are fitted with wash basins with fresh water laid on.

The Captain's suite and chartroom are provided with rectangular brass framed windows; brass framed circular sidelights of swivel pattern are fitted in officers' accommodation. All other sidelights are of the brass framed hinged pattern, and all sidelights on the main deck are fitted with deadlights.

A refrigerated store room is arranged on a flat below the main deck aft and includes a cold store room, a vegetable room and a handling room. The insulating medium is slab cork faced with cement. The cold chamber is served by an electrically driven, automatic control, Hallmark Methyl Chloride machine by J. & E. Hall, Ltd.

Storerooms are arranged for stewards' stores, bonded stores, boatswain stores, paint locker and cable stores. Fully equipped workshops are provided for the joiner and carpenter.

#### *The Bridge.*

The navigating bridge (Fig. 4) at the forward end of the bridge deck is enclosed in a teak wood house with large windows, a proportion of which are of the frameless, sliding type. Two Kent clear view screens are fitted on each side of the bridge front. The navigational instruments include a "Huson" vertical card reading steering compass; Chadburn's revolution indicators; Chadburn's mechanical telegraphs, one to the engine room and a steering telegraph to the bow baulks, so that when on cable work the cable officer forward can control the course. Engine room telegraphs are also fitted forward at the bow baulks for use when on cable

work. A Siemens' rudder indicator is provided and a large helm indicator geared to the steering telemotor is fitted to the bridge front for use on cable work. Telephones by Siemens Bros. are fitted for communication to engine room and bow baulks. In addition voice pipes are used for communicating with the radio office, crow's nest and poop. A folding chart table is also provided. An "Ardente" loud hailer is fitted for direct communication over short distances and two "Aldis" lamps are supplied for visual signalling. Control switches for de-gaussing coils are also fitted.

The chartroom opens off the bridge house; it is fitted with the usual chart table with stowage for charts, chronometer box, bookcase and wardrobe. The navigational instruments include a Marconi

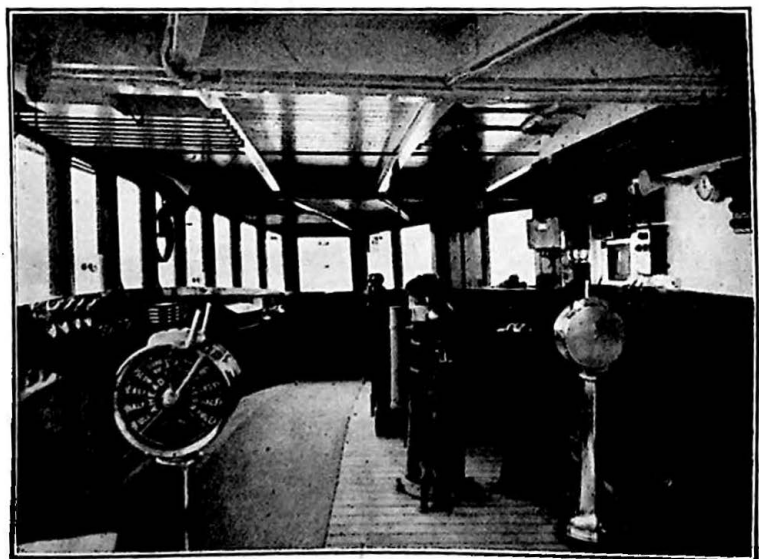

FIG. 4.—H.M.T.S. "IRIS." NAVIGATING BRIDGE.

type 579 direction finder with separate goniometer; two Husun echo sounders; one Challenger type for deep watersounding and one Universal type, sounding in feet, for shallow water work. A Husun hand sounding machine is fitted aft as emergency equipment and for use in obtaining bottom samples. A Pitometer log, type MM, is provided, giving speed in knots and distance run; also a Walker's trident electric log towed from aft with a recorder in the chartroom. The usual outfit of chronometers, clocks, aneroid and mercurial barometers is provided. In addition a Barr & Stroud 80 cm. base navigational range finder is provided for ranges below those measured by the large instrument and also for use in boat work; also a special survey sextant, and a high grade station pointer.

On the upper bridge are fitted the Husun standard compass; a Barr & Stroud 6 ft. base navigational range finder; two 16 in. searchlights fitted with signalling shutters and a chart table with folding hood. Due to war conditions the compass outfit was changed and Admiralty compasses, fitted with compensating coils for the degaussing system were provided instead.

In general the ships are provided with the normal outfit of fire fighting appliances, including perforated steam injection pipes in the forehold and storerooms.

#### *Electrical Equipment.*

The radio outfit comprises direction finding equipment as mentioned above. The main installation is a Siemens type S.B.402 combined transmitter and receiver of 100 W output capable of sending on two wavebands; 500 kc/s to 375 kc/s and 3,000 kc/s to 1,500 kc/s on I.C.W. and C.W. also on telephony. The receiver operates from 3,000 kc/s to 166 kc/s. There is in addition a Marconi type 730 all wave receiver. For ship's broadcast entertainment a Rees-Mace M.N. 100A broadcast receiver is provided serving five loudspeakers throughout the ship.

The test room is on the port side at the forward end of the bridge house on the shelter deck and is panelled in polished mahogany-faced plywood. The furniture is of mahogany and includes a test bench on the forward bulkhead with storage lockers under, knee-hole writing desk and chair, and a cabinet with filing compartments and bookshelves in the upper part for storage of cable records, and drawers in the lower part for the storage of cable charts.

The ship's testing equipment is for D.C. testing only and includes two main sets with permanent wiring. For communication with the shore there is a telephone and also a telegraph set for double current simplex working and a morse inker. The testing battery, made up of DS.5 Leclanché cells, is stowed in a locker under the test bench and tappings are taken to an 8-way plug switch on the bench top, so that varying battery powers from 5 cells to 60 cells can be obtained with ease. The testing leads (8 core 107/150 G.P.) are of sufficient length to extend to the bow baulks and are terminated on a testing board fitted with jacks and terminals mounted on ebonite. The telephone and telegraph sets also terminate on the board for ease in connecting up to the cable end. There is an earth connection on the

board, the earth being taken from a bolted connection to the ship's hull. A battery change-over switch is also fitted to the board for the supply of power to either main set as may be required. The testing board is mounted on the bulkhead forward of the testing bench and is easily accessible.

The main testing sets are all precision instruments manufactured by H. W. Sullivan, Ltd., unless otherwise stated. The first set is for measurements of conductor resistances and general testing and consists of a Wheatstone bridge with seven dial rotary switches, two for the ratio arms and five for the variable resistance to one decimal place on even ratio arms. A battery reversing switch is fitted at the side of the bridge case and there is also a rotary quadrant switch for use in taking Varley tests. The main galvanometer is a Sullivan marine type, but the usual galvanometer used with this set is a Galvanometer No. 25A or a Tinsley moving coil reflecting galvanometer, pattern S.S.1, type 580. A rotary switch universal shunt is used in this circuit. There are two wandering leads, from the line and earth terminals on the bridge for plugging into the required positions on the testing board.

The second set is mainly used for determining insulation resistance and capacitance by comparison with standard instruments which consist of a standard megohm resistance and a standard condenser of a fixed value of  $1/3 \mu\text{F}$  capacitance, together with a four-dial universal shunt. Incorporated in the circuit is a galvanometer short-circuiting key, a battery reversing key and a Rymer-Jones charge and discharge key. This set can be used with either the main Sullivan marine galvanometer or a Tinsley reflecting galvanometer. One wandering lead is provided from the shunt of this set for normal working.

Other testing equipment provided includes a Sullivan's portable combination cable test set made up of a precision four-dial Wheatstone bridge, Sullivan's marine galvanometer, rotary switch universal shunt incorporating a standard 100,000 ohm resistance and a standard condenser of  $1/3 \mu\text{F}$  capacitance, together with a Rymer-Jones charge and discharge key, and a plug switch for selecting the circuit required. This set is used when a testing party has to proceed ashore to test submarine cables. A Sullivan's simple capacitance test set is used mainly for locating disconnections in multi-core G.P. cables. A Wheatstone bridge with a five-dial variable resistance and plugged ratio arms, two galvanometers (No. 25A) and one Tinsley (patt. S.S.1, type 580) reflecting galvanometer are provided as spares and for making up testing sets as may be required; an Ohm-meter No. 5 is provided for tests on paper insulated cables.

Other special apparatus includes electrode detector gear for the location of earth faults in submarine cables. A scissors transformer is used in conjunction with a 2-valve amplifier and a reed hummer to provide tone; this equipment is used to identify submarine cables of similar type of armoring lying in close proximity to each other where the positions of the cables are not known with sufficient accuracy. A search coil (No. 1) and a tester (S.A. 9001) are also provided for searching for buried shore ends of cables.

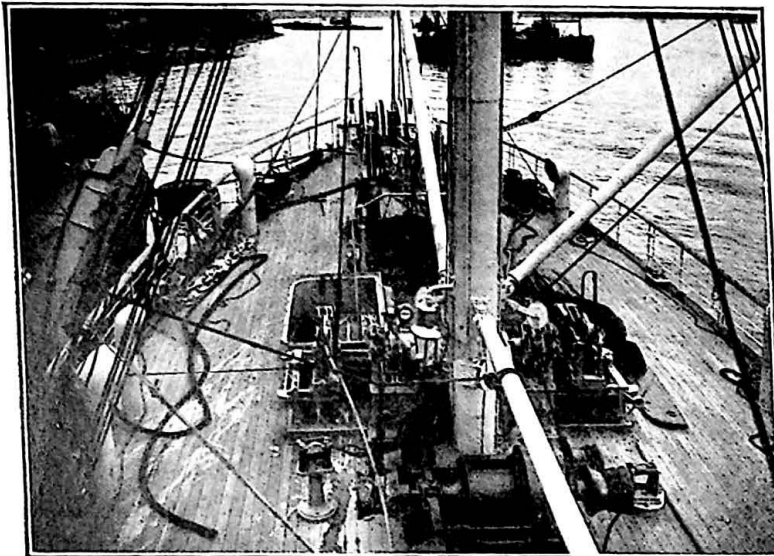

FIG. 5.—H.M.T.S. "IRIS." GENERAL VIEW OF FORE DECK—LOADING CABLE AT DEPOT.

#### *Cable Machinery.*

The cable machinery was manufactured by Messrs. Johnson & Phillips and, in addition to the double combined picking up and paying out gears (Fig. 5), includes a two sheave bow gear with sheaves 4 ft. 6 in. in diameter on flat treads and 14 in. wide between flanges, the bow gear being fitted with two swinging davits for handling mushroom anchors, grappels, etc. Two dynamometers are provided, one on each side, for indicating the strain on the gear from 7 cwts. to 30 tons, together with their associated span lead sheaves. Cable deck leads with vertical and horizontal rollers and spectacle leads are provided as necessary between the cable engines and the cable tanks.

The double combined picking up and paying out gear is mounted on a welded steel frame and fitted with two overhung drums each 6 ft. 6 in. diameter on the tread, 7 ft. diameter on the flange and 22 in. wide between flanges fitted with renewable cast steel brake treads. Each drum is fitted with a screw brake which has a steel strap lined with elm blocks. The brake is controlled by two hand-wheels on the shelter deck; one hand-wheel gives quick action and the other gives a slow but much more powerful effect. This arrangement, which is easy to manipulate, gives quick action and fine adjustment for paying out cable and a large reserve of power for holding the load. Water from the ship's wash deck supply is fed at the surface of the brakedrum and provides for lubrication and cooling.

Each drum is provided with two fleeting knives for fleeting the cable on the drum with either an inside

or outside lead. The hauling-off and holding-back gear is mounted on the shelter deck abaft the drum and provides for the proper tension of the cable on the drum when picking up or paying out. A Harding six-figure counter with quick zero-resetting device, indicating in fathoms, is fitted to each drum.

The gear is driven by two Clarke Chapman & Company's 3-cylinder, vertical type steam engines, each developing 110 B.H.P. at 260 r.p.m. with a working pressure of 200 lb./sq. in., exhausting to the main condensers. The control gear is situated on the shelter deck adjacent to the brake wheels, where the cable engine driver has full control, and at the same time is able to keep the dynamometers and bow baulks under his observation. The gearing of the machinery is so arranged that:—

- (a) Either engine can drive both drums to give the following maximum working loads on each drum:—  
7.5 tons at 100 ft. per minute.  
2.5 tons at 250 ft. per minute.
- (b) The after engine can drive the starboard drum while the forward engine is driving the port drum to give either of the under-noted maximum working loads on each drum:—  
15 tons at 100 ft. per minute.  
5 tons at 250 ft. per minute.  
This is the normal working condition.
- (c) Both engines can drive either drum to give the maximum working load on the drum in gear of:—  
30 tons at 100 ft. per minute.  
10 tons at 250 ft. per minute.



FIG. 6.—H.M.T.S. "IRIS." ENGINE ROOM (LOOKING AFT).



(d) To obtain the maximum braking effect the brakes can be interconnected through the gearing, so the pressure of both brakes can be applied to either drum. The brakes can work independently on the drum to which they are attached.

A portable cable transporter driven by an 8 H.P. electric motor and manufactured by Johnson & Phillips is provided for handling cable between tanks and on occasions when the main cable machinery is not essential.

#### Propelling Machinery.

The propelling machinery consists of two triple expansion, direct acting, surface condensing steam engines (Fig. 6) taking steam at 200 lb. per sq. in. working pressure from two single-ended, cylindrical, multi-tubular boilers fitted with Howden's system of forced draught. The boilers are oil fired on the Wallsend-Howden system; two Weir's oil fuel pumps are included, as well as four Auto-Klean strainers. An oil-fired vertical Cochran boiler working at 100 lb. per sq. in. is provided for port use.

The H.P. steam chest on each main engine is fitted with a Cockburn-MacNicoll combined regulating throttle and emergency valve connected to an Aspinall governor. The front and back columns are of cast iron. The cross heads are fitted with ahead and astern guide shoes. The air pumps are Weir's "Monotype" and the circulating pumps are Drysdale's centrifugal type. Weir's feed pumps are fitted and also a Weir's surface feed heater. The feed water filter is by Carruthers. The bilge, ballast, sanitary and general service pumps are all of Thom, Lamont & Co.'s vertical duplex type. The fresh and salt water pumps by Thom, Lamont & Co. are in a special pump room on the port side between Nos. 1 and 2 cable tanks and are electrically driven. The oil fuel transfer pump is by Weir's and of vertical simplex type. A Weir evaporator with capacity of 15 tons a day and a Caird & Rayner distiller with a capacity of 500 gallons a day are provided.

All the shafting is of forged Siemens-Martin ingot steel. The thrust block is of the latest Michel type. The cast iron stern tube is fitted with brass bushes

lined with lignum vitæ. The propellers are of Stone's manganese bronze, four-bladed, solid type 9 ft. 6 in. in diameter with a pitch of 10 ft. 3 in. and fitted with cone covers.

The electrical installation comprises a Bellis & Morcom turbine driving a 30 kW, 110 V D.C. Lawrence Scott generator and as an auxiliary a Lister diesel driven 15 kW, 110 V D.C. generator. In addition a generator of 15 kW output at 110 V D.C. and driven by a steam-reciprocating engine is provided for extra loads due to the degaussing equipment.

The steering gear is by Brown Brothers and is their direct geared steam tiller operated by Brown's telemotor control. Other deck machinery comprises a Clarke Chapman steam driven windlass fitted in a compartment at the forward end of the main deck, with a warping capstan on the shelter deck above and driven from the windlass engine through gearing. The capstan is controlled from the shelter deck. Two steam driven Clarke Chapman single and double purchase winches complete the deck machinery; one winch is fitted on the foredeck to serve the foremast derricks and for general work on deck and the other winch is fitted aft to serve the mainmast derrick and for warping purposes. The whipping drums are capable of being fitted with 18 in. diameter driving wheels of "V" section for taking 3 in. manilla rope whips used for driving cable transporters when loading from the cable factories.

The engine-room workshop is well equipped and is provided with a lathe with 3 ft. between centres, a shaping machine, an emery grinder and a grindstone, all belt driven by a 5 H.P. electric motor.

During the war both ships have carried various types of defensive equipment, including a 12 pdr. HA/LA gun, 4 Oerlikon guns, twin Lewis guns, 4 P.A.C. rocket projectors and were fitted for balloons.

#### Conclusion.

Since this article was prepared a further, and much larger cable ship, H.M.T.S. *Monarch*, has been launched. It is hoped to describe this latest ship in a subsequent article.

TELEGRAPH AND TELEPHONE STATISTICS—SINGLE WIRE MILEAGES AS AT DECEMBER, 1945  
THE PROPERTY OF, AND MAINTAINED BY, THE POST OFFICE

REGION	OVERHEAD			UNDERGROUND		
	Trunks and Telegraphs	Junctions	Subscribers *	Trunks and Telegraphs †	Junctions ‡	Subscribers §
Home Counties .. .. .	14,285	45,740	346,688	1,782,104	409,478	1,437,761
South Western .. .. .	6,642	39,120	262,167	928,452	174,764	794,176
Midland .. .. .	6,053	35,088	205,710	1,023,015	300,686	1,049,458
Welsh and Border Counties	7,583	29,255	146,806	524,791	80,359	327,307
North Eastern .. .. .	10,068	22,278	173,140	826,395	238,976	1,013,891
North Western .. .. .	923	9,213	109,197	651,041	371,085	1,267,241
Northern Ireland .. .. .	9,816	11,251	34,449	109,880	43,518	142,516
Scottish .. .. .	21,984	34,374	184,184	767,426	248,086	857,646
Provinces .. .. .	77,354	226,319	1,462,341	6,613,104	1,866,952	6,889,996
London .. .. .	467	1,545	74,742	915,169	1,771,165	3,775,473
United Kingdom .. .. .	77,821	227,864	1,537,083	7,528,273	3,638,117	10,665,469

\* Includes all spare wires.

† All wires (including spares) in M.U. Cables. ‡ All wires (including spares) in wholly Junction Cables.

§ All wires (including spares) in Subs. and mixed Junction and Subs. Cables.

# A C.B. Telephone Exchange for Army Use

H. E. FRANCIS, A.M.I.E.E., and  
G. A. MANNING.

U.D.C. 621.395.72

The article gives details of a new C.B. exchange designed for Army use. Ease of installation is the keynote of the design, all components to which connection has to be made on site being wired to terminal strips. A universal type of relay set is provided for junction working to automatic, C.B. and magneto exchanges.

## Introduction.

TOWARDS the end of 1943 the War Office decided that a switchboard was required with a capacity for a larger number of lines than that given by any existing Army equipment, and asked the Post Office to assist in its development as a matter of urgency.

A small Development Committee was formed with members from the Post Office, the War Office, the Ministry of Supply and the Automatic Telephone and Electric Co., Ltd., and the first drafts of the manufacturing specifications and drawings were available in less than three months. Standard Post Office items, suitably finished to meet tropical conditions, were used wherever possible so that manufacture could commence without delay.

## Requirements.

The War Office stipulated that the design should be for a C.B. type exchange capable of serving 1,000 extensions and 200 junctions. An average exchange would probably need six positions and serve 300 extensions, but they saw the need for easy extension up to at least 18 positions. Meters would be required on extensions in some cases. It was anticipated that unskilled labour might have to be used

for the installation of the exchange and that therefore the design would have to ensure that only simple operations were required on site. Speed of installation was also important.

It was expected that the equipment would have

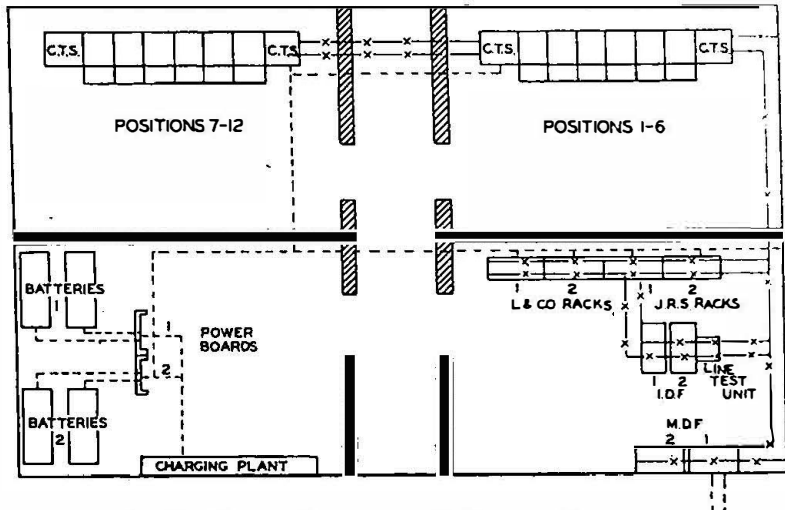

FIG. 2.—TYPICAL LAYOUT FOR 12-POSITION EXCHANGE.

to be housed in any building or hut that might be available, so that flexibility in lay-out was essential. In particular, it was anticipated that a switchboard with say 18 positions might have to be divided into three 6-position boards in separate rooms.

The exchange would have to work to magneto, C.B. and C.B.S. exchanges and to automatic exchanges as well, if this were possible without undue complication.

Line conditions were expected to be considerably below normal Post Office standards, and insulation resistance as low as  $5,000 \Omega$  was to be assumed with the loop resistance of extensions and junctions as high as  $1,000 \Omega$  and  $5,000 \Omega$  respectively.

The whole of equipment was to be so finished as to be capable of transportation to and operation in tropical climates.

## Outline of Exchange.

With these requirements in mind, it was decided to design the equipment as far as possible as a number of self-contained units to give flexibility in the layout and size of exchanges. For some purposes, e.g. the power plant and the M.D.F., it was necessary to

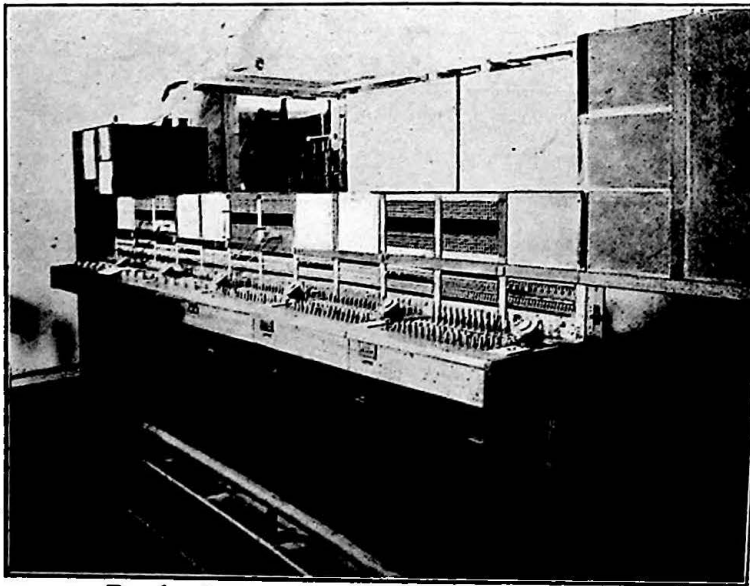

FIG. 1.—GENERAL VIEW OF 6-POSITION SWITCHBOARD.

decide on the size of an average exchange so that the capacity of the various component units could be co-related. This "average" size was fixed as a 6-position exchange serving 300 extensions and 40 junctions and was built up of 6 switch sections, 3 multiple units, 2 cable terminating sections and 1 each of the M.D.F., I.D.F., L. & K. relay rack, junction relay set rack, testing and miscellaneous equipment, cable and cable racking, meter rack, and power units. Other size exchanges can be built up by selecting the correct number of each type of unit. The general view of a 6-position switchboard is given in Fig. 1, and Fig. 2 shows a typical layout for a 12-position exchange in a four-roomed house.

#### Facilities.

The following is a summary of the main features of the equipment and of the facilities given:—

1. Any even number of positions can be installed, and can be divided into several small suites if desired. Angle sections are not provided.
2. A maximum multiple of 1,200 is allowed for and can be allocated between extensions and junctions as required. The multiple is in the form of units which can be easily fitted together on site.
3. 60 answering lamps and jacks are provided per position. 50 are normally allocated for extensions and 10 for junctions, but a different allocation can be made at the installation stage, if desired.
4. 16 universal cord circuits are provided per position. These cord circuits allow for ringing on both cords.
5. A small battery-driven ringer is fitted to each position, and adequate standby arrangements provided.
6. Junctions can be worked on a generator, C.B., or dialling basis by different strapping conditions on a universal relay set.
7. The equipment is designed to work from a 48 V supply.

#### Switch Sections.

The switch sections, which are 3 ft. high by 2 ft. wide, are constructed in a similar manner to the new P.O. sleeve control section, except that the face equipment provides for the answering field and miscellaneous circuits only. The answering field is equipped with 60 lamps and jacks, which are wired to tag blocks at the rear of the position. The large number of 10 plugging-up jacks per position is provided for use with double-ended cords, as it was thought that they may be required under emergency conditions.

The keyboard is fitted with 16 pairs of connecting cords and associated supervisory lamps, speak, ring and

meter keys. A double-ended cord is also provided for test purposes. Other equipment includes a dial and a ringing changeover key, and on the later models three traffic meters, operated by keys near to the

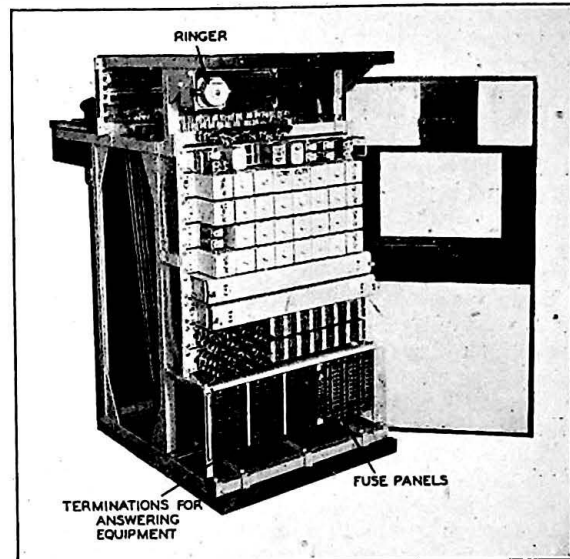

FIG. 3.—REAR OF SWITCH SECTION.

dial, are fitted in the lock rail. Two operators' telephone jacks are provided, one a Post Office standard and the other of the four-pin type so that an army pattern headset can be used if desired.

The cord circuit relays are of the 3,000-type and are mounted in the rear of the section as shown in

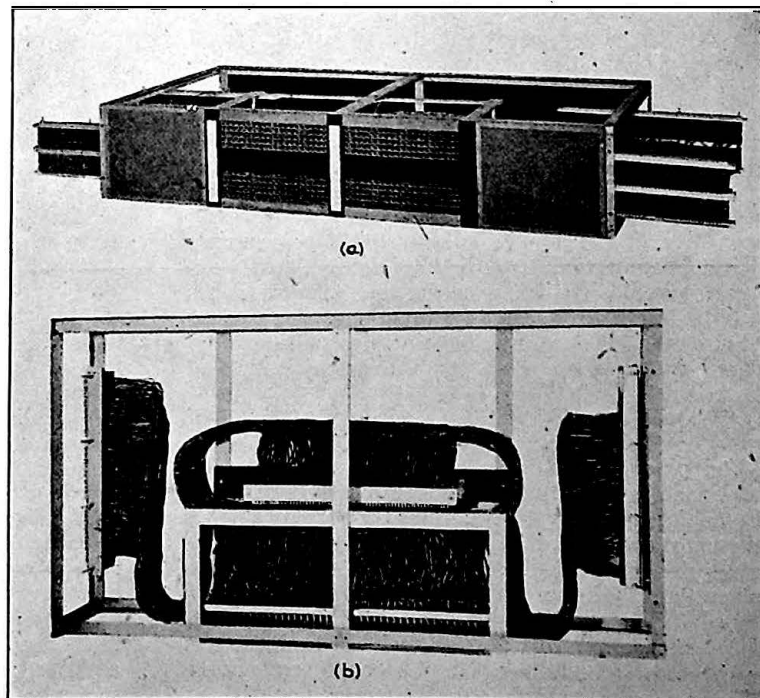

FIG. 4.—MULTIPLE TURRET UNIT.

Fig. 3. Each position has fuses for its own cord circuits, lamps, and miscellaneous equipment, with a fuse alarm lamp on the front of the board.

A small battery-driven ringing machine is provided in each position with a key for coupling to the position either to the right or left in case of failure. By this arrangement each operator has the equivalent of two standby ringing supplies with the exception of those on the end positions, and a hand generator was therefore considered superfluous. The ringing machine has an output of  $2\frac{1}{2}$  W at 75 V and is worked on a stop start basis, reaching full output within 40 mS. Its percentage harmonic output is small.

#### *Multiple Turret Unit.*

This consists of a rectangular iron frame which fits on top of a pair of switch sections. It has four panels, of which the two centre ones carry a total of 400 outgoing multiple jacks; the end panels are blank and are intended for use as bulletin boards. (Fig. 4 (a)).

Behind the blank panels are accommodated pinch type tag assemblies for connecting the multiple unit to adjacent multiple units or to the cable terminating section (C.T.S.). The pinch type tag assemblies are similar to those employed for the commoning of selector bank multiples in the earlier type of automatic exchanges, and are made up of strips of insulation threaded across with 60 flexible brass tags. Each jack is wired to three tags (T, R and S), so that one strip carries connections for 20 jacks. The strips are mounted in assemblies of 10 serving 200 jacks. Connection to adjacent multiple or C.T.S. units is made by dismantling the assemblies and interleaving the tag strips with those of the adjacent unit. The ends of the tags are subsequently soldered to ensure a good contact. The multiple can be extended in this manner to cover as many positions as desired.

For transport, tag strip assemblies are turned inside the unit and fixed securely, as shown in Fig. 4 (b).

Up to three multiple units can be placed one on top of another, so that a total of 1,200 multiple can be obtained. It is possible to use any multiple jack for connection to either a junction or an extension circuit, but it is usual for one or more blocks of 100 jacks to be allocated for junctions. The various junction routes are marked by designation pegs placed in the jack preceding the first junction of the route.

#### *Cable Terminating Section.*

The pinch type tags mentioned are not suitable for connecting directly to switchboard cable, so a C.T.S. (Fig. 5) is provided which contains tag strip assemblies wired to ordinary tag blocks for terminating the cables from the I.D.F. (see Fig. 1). It is equipped to take the maximum of 1,200 multiple, and also houses the fuse and night alarm bells. A C.T.S. is placed at each end of a suite and the multiple can be extended to another suite by coupling from the C.T.S. at the end of the first suite to the C.T.S. at the beginning of the second suite. The C.T.S. is

fitted with removable metal covers, so that normally the whole of the equipment is totally enclosed.

#### *M.D.F. Unit.*

The main distribution frame is a single-sided frame of seven verticals designed with both floor and wall fixings. The lower half of the frame carries the fuse

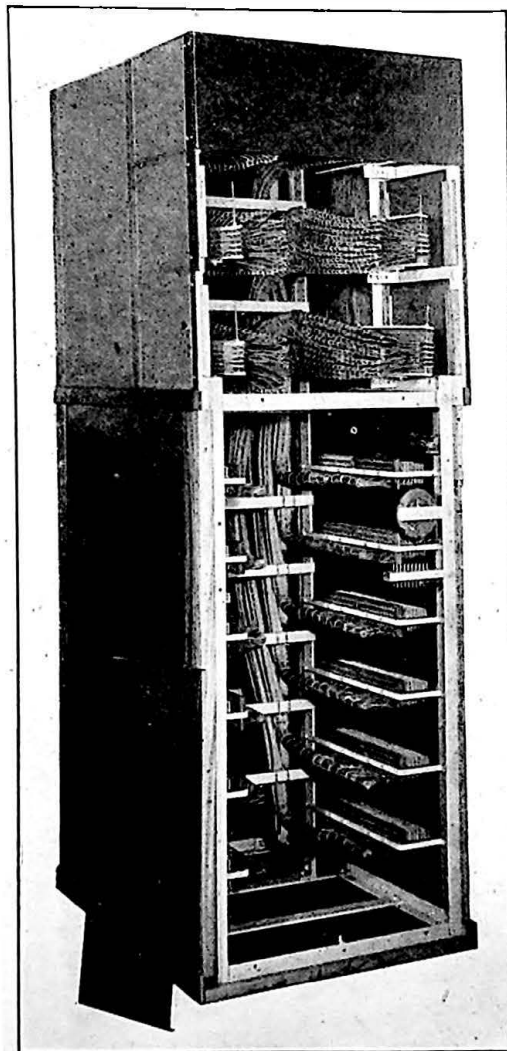

FIG. 5.—CABLE TERMINATING SECTION.

mountings with a capacity for a total of 560 lines. The protectors are fitted on the upper half of the frame and have a total capacity for 420 circuits.

#### *I.D.F. Unit.*

The intermediate distribution frame is of similar construction to the standard P.O. type, but is of reduced height. The local side is fitted with 18 tag blocks for connection to 360 answering jacks, and on the multiple side 20 tag blocks are fitted for connection to the multiple field of 400 jacks. In addition, four tag blocks are fitted on each side of the frame for terminating the incoming and outgoing side of 80 junction relay sets.

A six-way tag block is used on the multiple side of the I.D.F. for the termination of the circuits from the M.D.F. and the multiple jacks. The M.D.F. circuits are terminated on Tags 2 and 4 (marked A and B), and the multiple jacks are terminated on Tags 1, 3 and 5 (marked T, R and S). When meters are used, they are connected to the sixth tag marked M. When a multiple jack is used for an extension, Tags T and A, Tags R and B, and Tags S and M are strapped and the circuit jumpered from Tags T, R and S to the answering equipment in the usual way. For junction working these straps are omitted, and separate jumpers run from Tags A, B and S to the incoming side of the relay set, and from Tags T and R to the answering jack. The outgoing side of the relay set is terminated on a separate four-way tag block and jumpered to the answering lamp and jack.

#### L & K Relay Rack.

This rack (Fig. 6) is equipped with 300 pairs of L & K

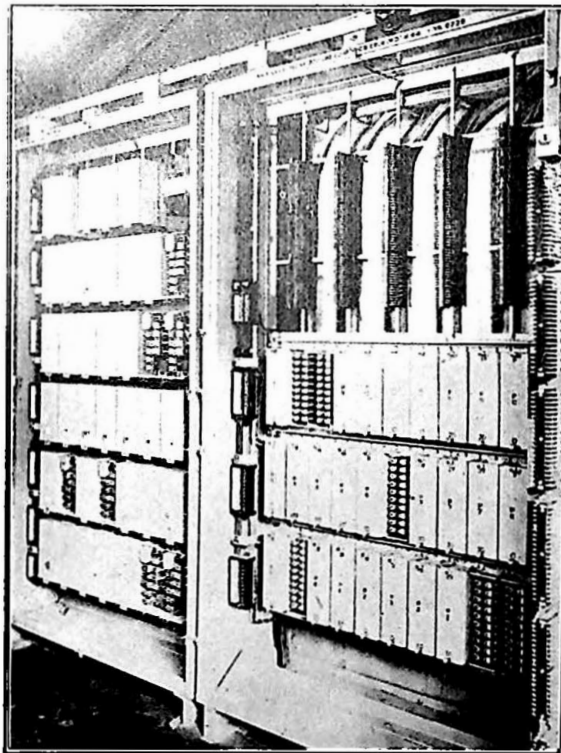

JUNCTION RELAY SET RACK. L AND K RELAY RACK.  
FIG. 6.—APPARATUS RACKS (COVERS REMOVED).

relays of the 600 type. They are mounted on the lower part of the rack and wired out to tag blocks mounted above. The battery supply is connected via fuse panels from busbars mounted on the left-hand side of the rack, and the fuse alarm equipment which is individual to each rack is located on the right-hand side.

The whole rack is enclosed in a sheet metal case similar to that employed for the small type U.A.X. equipment. It is provided partly for protection against mechanical damage, but chiefly to enable the humidity to be controlled by inserting a small electric heater in the bottom of the case.

#### Junction Relay Set Rack.

The junction relay set rack (Fig. 6) is of similar construction to that used for the L & K relay rack, but is fitted with six shelves accommodating a total of 40 relay sets. The relay set jacks are wired to a tag block mounted at the rear of each shelf. Battery supply and alarm equipment is similar to the L & K rack.

The relay set is of the 2,000 type, with a total of nine relays. It is designed to terminate junction circuits for C.B. working, generator working or automatic working, each condition being given by different strappings on a small 50-point tag block mounted beside the relays.

The strappings have been arranged to present a regular appearance, so that the type of facility provided is easily apparent. When the relay set is manufactured, all tags points are commoned vertically and the wires are cut on site to conform to the desired method of working, a soldering operation being unnecessary.

#### Cable Runways and Cabling.

Owing to the various conditions under which the exchanges are to be installed, it is necessary to provide a flexible cabling scheme. Flexibility in the cable runways is provided by supplying a number of 6 ft. lengths which can be fastened together by special brackets to give any desired layout. To simplify the work, each rack and frame is equipped with a length of cable runway along its top.

To prevent trouble from low insulation in cable runs, which may have to go through walls or along corridors, P.V.C. covered switchboard cable is used. It is pre-waxed and supplied in 4 sizes, viz., 21, 41, 61 and 81 wire. All the cables are connected on site to either tag blocks or fuse mountings, so that the work of lacing-out and terminating is not difficult.

#### Testing Equipment.

Sufficient testing equipment is provided to enable the exchange to be adequately maintained. The line testing equipment was designed separately by the Ministry of Supply and gives facilities comparable with the normal test desk. It is mounted on a test rack which also holds a unit equipped with 10 generator signalling answering circuits for use as faultsmen's lines and one or more units of test jacks. These test jacks are included in the wiring of all junction circuits between the I.D.F. and the incoming side of the junction relay set.

The cord circuits and the L and K relays on the extension circuits can be tested for correct operation under onerous conditions by equipment fitted in each switch section. For junctions, however, a relay set tester is provided (Fig. 7). This tester has space for a relay set to be jacked in and the various methods of working and junction conditions can be simulated by the operation of keys. The tester is fitted with lugs for mounting on the rear of the test rack if required.

#### Power Plant.

24 V charging equipment and batteries were already Ordnance items, which it was desired to use for this exchange. This meant that the equipment

would have to be designed to work from a voltage of either 24 or 48 if the battery was split for charging purposes. A 48 V supply was eventually decided upon as it would enable higher resistance extension circuits to be worked without local batteries, and,

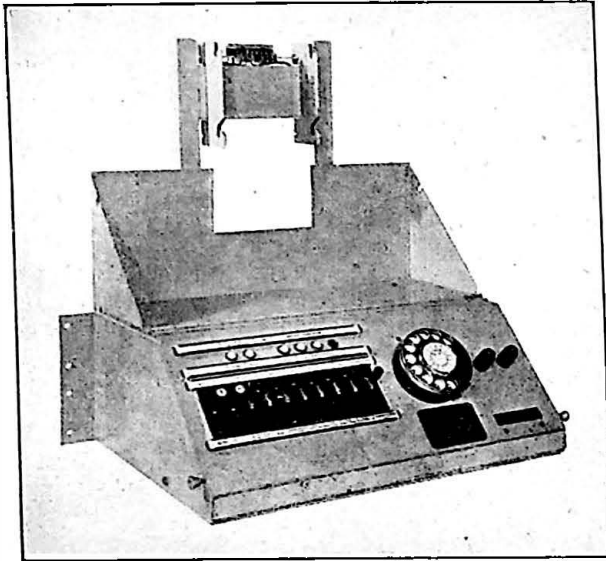

FIG. 7.—JUNCTION RELAY SET TESTER.

in addition, it was hoped to make use of existing designs of 600 and 3,000 type relay coils if possible. The batteries available are of the enclosed type with a capacity of 170 Ah. The chargers give an output of 10 A and incorporate a metal rectifier. Two or more such chargers can be paralleled for larger outputs. A small petrol engine set is also available for those places where there is no A.C. supply.

Owing to the many sizes of exchange likely to be encountered, it was decided to supply one power plant for every 6-position exchange, but the busbars would be commoned on the larger exchange. A normal power plant consists of two batteries worked on the charge-discharge basis, together with the charging equipment and the power board. The power board (Fig. 8) employs a totally enclosed iron-clad switch for each battery, and in one position puts the two halves of the battery in series and connected to the exchange load, whereas in the other position the two halves of the battery are paralleled and connected to the charging switch. The charging switch is also iron-clad and enables either of two charging plants to be selected, or in the centre position to disconnect the circuit altogether. The distribution leads to each rack and switch section are fed from connecting points, suitably labelled, at the bottom of the power board. By this method, it is hoped to overcome any difficulties which might arise due to overloading the distribution leads if a commoning system from rack to rack, or switch section to switch section, were employed.

#### *Junction Working.*

Owing to the uncertainty of the conditions under which the exchange will have to work, a universal relay set has been used which can be easily arranged

to work to any type of distant exchange likely to be met with in practice. C.B. and generator are standard methods of signalling, but on calls to automatic exchanges several methods are used, and it was not practicable to meet all conditions. It has therefore been arranged that lines to automatic exchanges are terminated on subscribers' calling equipment at the distant end as a normal method of working, but other facilities can be given if the equipment exists at the distant automatic exchange.

The circuit of the junction relay set is given in Fig 9, and the method of operation is outlined below.

#### *(a) C.B. Working.*

The B line is connected to the L relay for the receipt of calling signals via contacts S2 normal, and both lines are switched direct to the jacks via S2 and S3 whenever a plug is inserted. Calling and supervisory signals are then controlled by the cord circuit.

#### *(b) Generator Working.*

The exchange side of the transformer is connected to I/C and O/G jacks and the cord circuit supervisory control is provided from the A relay.

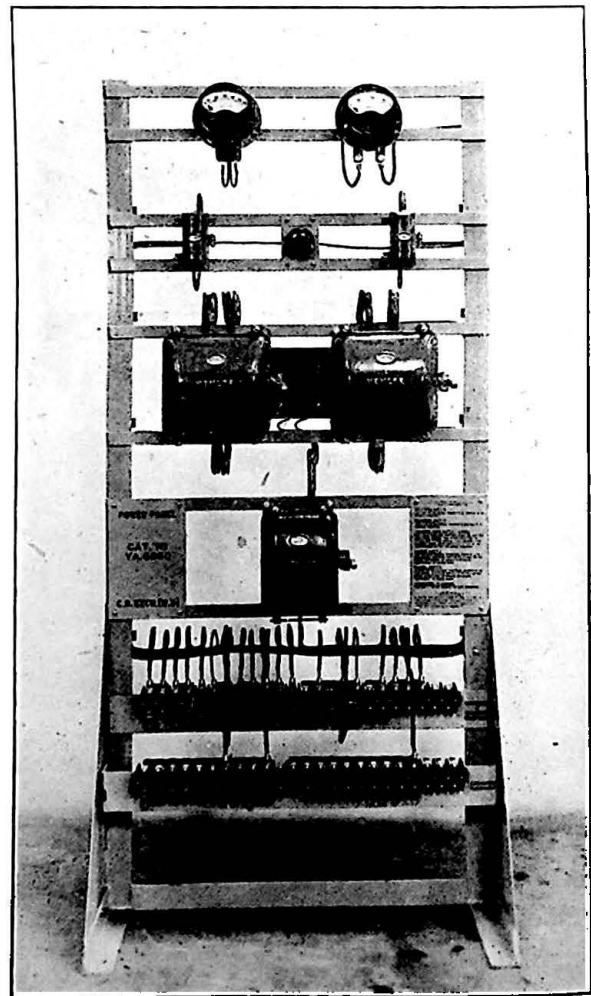

FIG. 8.—POWER BOARD.

The line side of the transformer is connected to the A and B wires when S relay is operated by the insertion of a plug in either the I/C or O/G jack. When the ring call key is operated, relays RR and RX operate and connect ringing current direct from the cord circuit to the line.

The L relay, which is permanently connected across the line, operates to an incoming A.C. signal and, in conjunction with LR and LD relays, completes the circuit for the calling lamp or supervisory relays in the cord circuit. These signals are permanent until the call is answered or the supervisory signal is released. The supervisory signal on an incoming call may be either a clear or a recall, and if the operator wishes to darken the signal without clearing the connection he may do so by ringing on the answering cord. False clear signals to the distant exchange are prevented by contact SS4.

transmits loop impulses to line. With the key restored, and on receipt of the subscriber's answer reversal from the auto exchange, relay LA operates disconnecting relay LD, which in turn connects supervisory battery to the tip of the plug at LD1. On I/C calls, an automatic ringing signal from a final selector will operate relay L, which in conjunction with relay LR provides a permanent glow on the calling lamp. When a plug is inserted in the answering jack the loop trips the auto ringing and speaking conditions are established. Contact SS4 disconnects LD relay, and the cord circuit supervisory lamp is darkened. In some cases it will be possible by suitable jumpering arrangements at the automatic exchange to provide a reversal for an incoming call, i.e. LA will operate to the auto final selector bridge and not to the subscribers' equipment. Full supervision can be given in these cases.

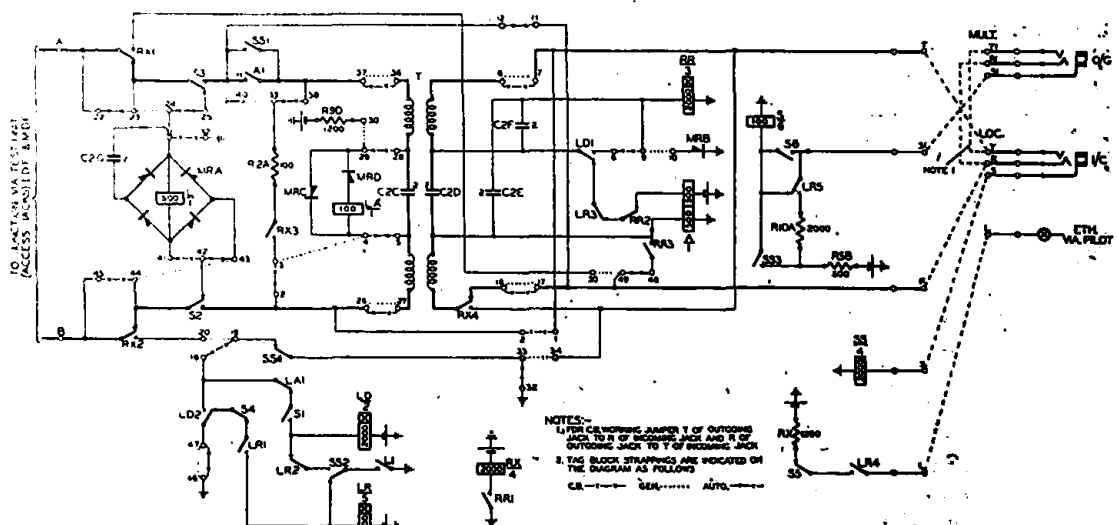

FIG. 9.—CIRCUIT OF JUNCTION RELAY SET.

### (c) Automatic Working.

The exchange side of the transformer is connected to the jacks and the cord circuit supervisory control is provided from the A relay.

Under normal conditions, the line relay L is connected to the A and B wires. When a plug is inserted in either the I/C or O/G jacks, relays S, SS and A are operated, and the line relay is replaced by relay LA and the transformer bridge, which present a loop to the auto exchange equipment.

When a plug is inserted in the O/G jack relay LA is not operated, but relay LD operates and connects relay RR to the tip.

When the dial key is operated RR and RK relays operate and connect one coil of A relay to the ring, and provide a 100 Ω shunt across the line transformer bridge.

The operation of the dial causes relay A to respond to battery impulses from the cord circuit, and A1

Junctions can be worked battery dialling on O/G calls and C.B. signalling on I/C calls by strapping the relay set for C.B. conditions.

### Conclusions.

A C.B. type exchange has been produced to meet the special requirements of the War Office, and the adoption of the unit principle of construction has given the necessary flexibility to the equipment. A number of these exchanges is now working and giving satisfactory service. In some of the exchanges the construction staff consisted mostly of unskilled labour; but little difficulty was encountered during installation.

The authors wish to acknowledge the assistance given by the Ministry of Supply and the Automatic Telephone and Electric Co., Ltd., in making available the photographs included in this article.

# The Unit Bay IB Coaxial Cable Transmission System

R. A. BROCKBANK, Ph.D., B.Sc., A.M.I.E.E., and  
C. F. FLOYD, M.A., A.M.I.E.E.

## Part 3.—Terminal Repeater Station Equipment

U.D.C. 621.395.44

The Unit Bay IB System can transmit 660 circuits in the frequency range 60-2,852 kc/s over two  $\frac{3}{8}$  in. diameter coaxial tubes. The terminal stations contain H.F. repeaters and equalisers similar to those at any intermediate station in addition to the supervisory and control equipment for the whole route.

### Functions of Terminal Stations.

THE terminal stations on a Unit Bay IB route have three main functions:—

- (a) To terminate the H.F. transmission path in a suitable manner for connecting to the modulating or demodulating equipment.
- (b) To control the characteristics of the H.F. transmission path.
- (c) To serve as a focal point for the indication and location of any fault arising in the system.

The two terminal stations on a route are referred to as the Control and Remote terminals; although the main H.F. transmission equipment is similar at each, they differ in that most of the control and supervisory facilities are grouped at the Control terminal, which is, therefore, invested with the responsibility of initiating all fault clearing and maintenance and, in general, ensuring efficient operation of the system.

### Layout of Terminal Stations.

The layouts of the two terminals have been made uniform on all standard Unit Bay IB routes. Fig. 1 shows a Control terminal installed at the P.O. Training School at Cambridge; it comprises three 10 ft. 6 in. high bays, which are generally described as the H.F. bay, the Control bay, and the Supervisory bay respectively. Each bay is fitted with its own power panel and the H.F. bay can feed power over the coaxial tubes in a similar manner to an intermediate power-feeding station. The Remote terminal contains only two 10 ft. 6 in. bays, consisting of an H.F. bay identical to that at a Control terminal and a Supervisory bay, somewhat similar to its counterpart.

#### H.F. CIRCUIT

A block diagram of the complete H.F. circuit over a route is shown in Part 1.<sup>1</sup> The main H.F. circuit at the two terminals is shown in more detail in Fig. 2 and is similar to that at an intermediate station with the addition of Send and Receive H.F. control panels.

<sup>1</sup> P.O.E.E.J., Vol. 38, p. 45.

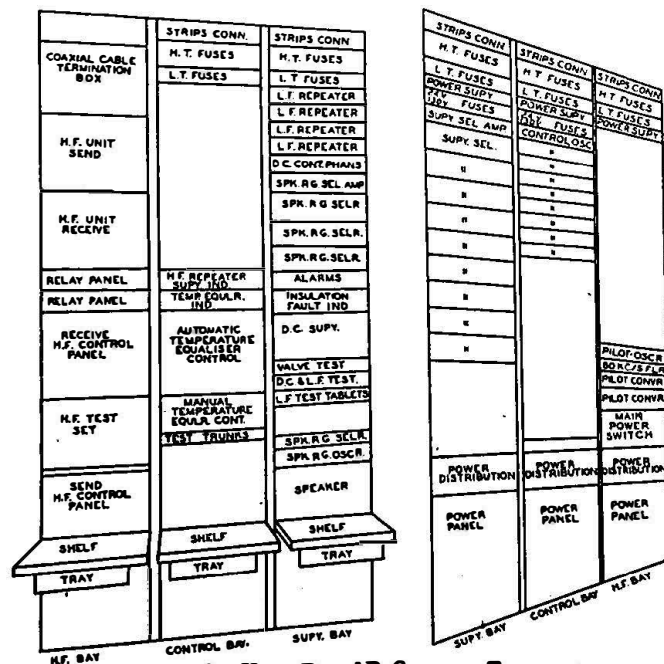
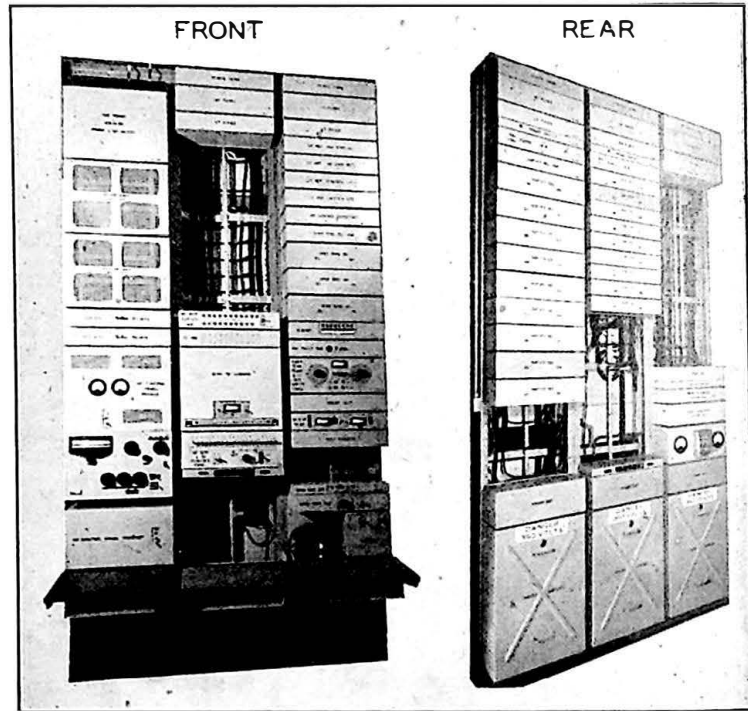

FIG. 1.—UNIT BAY IB CONTROL TERMINAL.



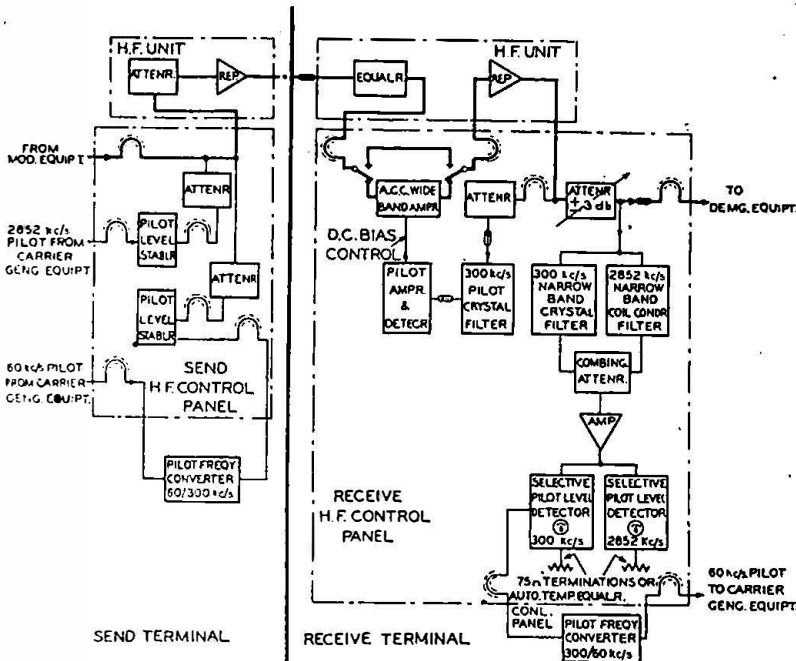

FIG. 2.—BLOCK SCHEMATIC OF H.F. CONTROL PANELS.

*Send H.F. Control Panel.*

The 300 kc/s and 2,852 kc/s pilots from the frequency generating equipment are here superimposed on the H.F. signals after passing through individual pilot stabilisers consisting of automatic gain control amplifiers, which give almost constant output levels for input variations up to  $\pm 6$  db.

*Receive H.F. Control Panel.*

This terminates the H.F. circuit, provides the outgoing coaxial connection to the demodulating equipment and carries receive pilot level indicators and pilot output points. The wideband automatic gain control amplifier, also fitted on this panel, has a gain of  $0 \pm 3$  db. and is looped into the low level circuit preceding the final repeater, to maintain constant to  $\pm 0.2$  db. the overall gain of the incoming transmission path in response to the received level of the 300 kc/s pilot. The A.G.C. amplifier is automatically rejected and an alarm is given if pilot level variations in excess of  $\pm 3$  db. occur.

**SUPERVISORY CIRCUITS**

The supervisory facilities on the system have already been illustrated in Fig. 4, Part 1. They are designed to indicate the condition of the H.F. circuits and equipment along the route and to give visible and audible alarms at the Control terminal if abnormal conditions arise. They can be grouped as follows:—

*(a) H.F. Repeater Supervisory Signal.*

This operates at the Control terminal. The L.F. tone from each repeater station operates one of a bank of rectified-reaction selectors, which in turn is connected to a lamp on the H.F. repeater supervisory indicator panel. When, at an intermediate station,

either the Go or Return "A" repeater fails and its "B" repeater is brought into circuit, the appropriate lamp for this station glows on the repeater supervisory panel at the Control terminal.

*(b) D.C. Supervisory Signal.*

The primary duty of the D.C. supervisory signal is to locate a power failure on the route, since when this occurs, the other supervisory circuits cease to function. It is also used to locate a valve failure in the L.F. repeaters and to measure the average temperature of the cable along the route to serve as a guide in temperature equalisation. The D.C. supervisory panel at the Control terminal operates in conjunction with two interstice pairs over the whole route and in the "waiting" condition has two alarm relays in series with the "A" legs of these pairs. The "B" legs are looped at the remote terminal and earthed on this panel. A power failure or L.F. repeater valve fault

at any station connects the appropriate A and B legs and operates the alarm relay. In the "Locate Fault" condition, which can then be set up, by throwing a key on the D.C. supervisory panel, a simple Wheatstone bridge circuit using a null galvanometer locates the fault on a dial engraved directly with the station names. The relative temperature is obtained in a similar manner by balancing the bridge with a dial calibrated in  $^{\circ}$ C. This fault locating circuit is self-compensating for resistance temperature changes in the interstice pairs.

*(c) Speaker Circuits.*

The ringing frequencies for calling intermediate power-feeding stations over the 4-wire speaker are obtained from an L.F. oscillator, fitted with a selector switch to set up the frequency corresponding to the name of the station to be called. Incoming ringing signals enter a bank of selective detectors each of which corresponds to a lamp on the speaker indicator panel, so that the identity of the calling station is indicated.

*(d) Pilot Level Indicators.*

These have already been referred to above. The 300 and 2,852 kc/s pilots are stabilised at the Send terminal, and at the Receive terminal the levels of these pilots are given on pilot indicator meters mounted on the Receive H.F. control panel, so that the route performance can be continuously observed and temperature equaliser adjustments made as demanded.

*(e) Insulation Fault Indicator.*

This panel operates between the conductors of an interstice pair and earth. It consists of a circuit comprising a single valve whose bias is derived from

a resistance potentiometer in which the insulation resistance between the conductors form one arm. Any ingress of moisture into the cable reduces the insulation resistance, and when this decreases to about 50 megohms an alarm is given.

#### CONTROL CIRCUITS

These, as distinct from supervisory circuits, control the operating conditions and performance of the H.F. transmission path. A functional description of the control transmission circuits has already been given in Part 2.<sup>2</sup>

##### (a) *Switching of "A" or "B" Repeaters.*

This facility is provided on the manual temperature equaliser control panel in order that the Control terminal can test the "B" repeaters on the route and may also switch out of service any "A" repeater suspected of faulty performance, e.g., excessive noise generation. The station at which "B" repeaters are required in circuit may be selected by depressing the appropriate station keys and the actual switching operation is then performed by operating the "Lock-in B Repeater" key; the former key transmits the voice frequency (V.F.) tone corresponding to the station required over the temperature equaliser control pair and the latter applies a D.C. potential to the same pair to initiate the correct switching function. The V.F. and D.C. potentials must be maintained for a few seconds to complete the switching operation. The tones are then removed and the Go and Return "B" repeaters at the selected station remain locked in circuit, the H.F. repeater supervisory circuit, meanwhile, indicating that the appropriate station has changed to the "B" repeaters. The "A" repeaters can be restored into circuit by a non-selective condition set up by depressing the "Lock-in all 'A' Repeaters" key. This restores all stations to their "A" repeaters, irrespective of the presence of the 300 kc/s pilot or the state of the "A" repeaters.

##### (b) *Manual Temperature Equaliser Control.*

This is accomplished from the manual temperature equaliser control panel by the two combinations of V.F. and D.C. potentials in a manner similar to repeater switching. As temperature equalisers may be switched only one station at a time and this in a prescribed order on each route, a mechanically delayed selector switch is fitted which can only be moved in single steps. This prepares the circuit to send out the V.F. tone corresponding to the station required. A key is then moved to either "Temperature Equaliser In" or "Temperature Equaliser Out," as desired, and a second key "Operate Temperature Equaliser" causes the selective potentials to be transmitted along the two interstice pairs. The system of key operation and tone switching has been designed and interlocked in a manner which makes the unintentional or incorrect changing of temperature equalisers practically impossible. Each route is designed to a temperature equaliser schedule which lays down the order in which stations are

actually to be switched. The step-by-step rotation of the selector switch follows this order and the schedule number prevailing appears at a window over the dial.

A "check-back" condition is included in the system whereby during the few seconds occupied by the temperature equaliser switching cycle, lamps light on the temperature equaliser indicator panel corresponding to each station at which the equalisers are in circuit. This indicator is operated by the V.F. tones of the H.F. repeater supervisory system which for this short time is automatically switched to give indications for the temperature equalisers instead of the repeater changeover.

The V.F. tones required for the control circuit selecting signals are generated in a bank of fixed frequency oscillators having standard V.F. telegraph frequencies. Their outputs are relay controlled from the selector switch.

##### (c) *Automatic Temperature Equaliser Control.*

A fully automatic control unit has been designed as an addition to the manual temperature equaliser control panel. It represents an operational refinement which it is intended to fit to standard routes as required, although at present the panel is regarded as experimental.

The 300 kc/s and 2,852 kc/s pilots from the receive H.F. control panel provide thermal control of the resistance balance of two metal filament lamps in a bridge circuit energised from a balanced 50 c/s half-wave source. The phase of the half-wave 50 c/s output, therefore, reverses as the relative levels of the pilots pass from positive through zero to negative, and the amplitude of this output is proportional to the relative signal levels for small differences. A high gain feed-back audio amplifier applies this out-of-balance signal to a pair of thyratrons in push-pull with pre-set bias, so that either one or the other will ionise and operate an anode relay as the relative levels of the 300 kc/s and 2,852 kc/s pilots change by more than a predetermined amount e.g., 1.5 db. Fairly complex relay and uniselector trains then perform the correct selection of the V.F. tones and D.C. potentials normally done by the maintenance man on the manual temperature equaliser control panel.

The unit is arranged to reject itself from circuit and give an alarm when sudden abnormally large changes in pilot levels occur, or if both pilots fail. There is thus no danger of the H.F. circuit being upset by excessive temperature equalisation caused by pilot failure.

##### (d) *Automatic Gain Control.*

The temperature equaliser correction is only concerned with maintaining the "slope" of the gain-frequency characteristic within desired limits, and it is no preventative against level changes of the whole frequency band. The A.G.C. device operating from the 300 kc/s pilot has already been described (Fig. 2) and maintains constant overall gain of the system at this frequency to within  $\pm 0.2$  db.

<sup>2</sup>*P.O.E.E.J.*, Vol. 38, p. 85.

#### MISCELLANEOUS PANELS

A few additional panels to which reference has not yet been made are fitted at the terminals.

##### *Pilot Frequency Convertors.*

These panels effect the conversion of the 60 kc/s pilot, required for locking the frequency generating equipment at the terminals, to the 300 kc/s required as a pilot on the Unit Bay 1B system. At the Send terminal the 60 kc/s is passed into a distorter valve followed by a 300 kc/s selector amplifier which then passes the output to the 300 kc/s stabiliser on the Send H.F. control panel. At the Receive terminal

the 300 kc/s is mixed with a 240 kc/s tone, derived from itself to give a 60 kc/s output which is selected and amplified by a narrow band amplifier.

##### *Trunk Test Panel.*

This is a small panel used for making connections between the front and back of the terminal bays. It terminates six pairs and two coaxial cables and may also terminate any remote test pairs which may be required.

##### *Rack Mounted Tester.*

This will be described in Part 4.

## Multi-Fee Metering at Non-Director Exchanges

H. S. WATERS

U.D.C. 621.395.36

This article describes the general principles of a scheme to enable non-director subscribers to complete calls automatically up to a chargeable distance of four unit fees where the required exchange is directly connected.

### *Introduction.*

PRIOR to the war a scheme was being developed to cater for non-director subscribers dialling to all exchanges within the multi-fee range, i.e., up to a call charge of 4-unit fees and was described in the article by F. Wilson and G. R. Sudell entitled "Multi-Fee Call Dialling and Registration at Non-Director Exchanges."<sup>1</sup> This scheme was not introduced, however, owing to labour shortages and manufacturers' commitments occasioned by the war.

For dialling to exchanges reached via tandem exchanges the original scheme included a discriminator

- (a) to discriminate between calls to the various exchanges reached over an outgoing route to the tandem exchanges in order to apply the correct number of metering pulses, and
- (b) to provide translation facilities so that the subscriber would not need to dial long trains of routing digits when dialling via intermediate exchanges.

### *Calls to Directly-connected Exchanges.*

Special fee determining equipment is not required on calls terminating at directly connected exchanges as a fixed fee applies to each route. Nor is translation required, as a 2- or 3-digit code suffices for routing purposes. Consequently it is possible to provide multi-metering facilities on calls to directly connected exchanges simply by arranging for the auto-relay sets on each route to give a fixed fee of 1, 2, 3 or 4 units. Moreover, in general, the traffic to directly connected exchanges forms the majority of multi-fee traffic (probably about 90 per cent.) and this traffic can thus be completed automatically

by subscribers without using the complicated and expensive discriminating and translating equipment which is necessary only for dealing with tandem traffic.

### *Tandem Traffic.*

The small proportion of traffic to indirectly connected exchanges can continue to be handled manually, subscribers being instructed to dial "0." Where this traffic is appreciable it may be economical to provide a comparatively small amount of the discriminating and translating equipment on a 2nd selector level, the subscribers dialling 4-digit codes, of which the last two operate the discriminator. (In the original scheme the discriminating equipment was connected to a 1st selector level, the subscribers dialling 3-digit codes.) The dialling of 4-digit codes for the tandem traffic is acceptable in view of the small proportion of traffic affected. An additional factor is that even if the discriminating and translating equipment were provided, its usefulness at the outset would be limited by the fact that many of the tandem routings are via manual exchanges and it would be necessary for these exchanges to be converted to automatic working before the fullest measure of tandem dialling could be achieved.

### *Satellite Exchanges.*

The multi-fee traffic originated by satellite exchange subscribers is routed to the main exchange over a single group of junctions, which also carries traffic to the other exchanges in the linked numbering scheme. As this group of junctions carries traffic of varying fees it is necessary to discriminate for metering purposes at the satellite exchange and

<sup>1</sup> P.O.E.E.J., Vol. 31, p. 5.

this is achieved by the same discriminating equipment that was designed for the original scheme and which is described in the article by F. Wilson and G. R. Sudell already referred to.

Briefly, this equipment provides all the facilities formerly performed by the discriminating selector, e.g., digit absorption on calls to other subscribers connected to the same satellite exchange, discrimination for calls to other exchanges in the linked numbering scheme, and to assistance and other service points at the main exchange. In addition, the

subscriber from using the multi-metering codes used by local subscribers and thus obtaining tandem calls at an incorrect fee, i.e., at the route fee applicable to terminating calls.

In future, all exchanges in a linked numbering scheme will, as far as possible, have a common charge list so that, as a common fee will apply, other non-director exchanges can have access to the whole of the linked numbering scheme. Where a satellite exchange has its own charge list, however, its fee from another non-director exchange may not

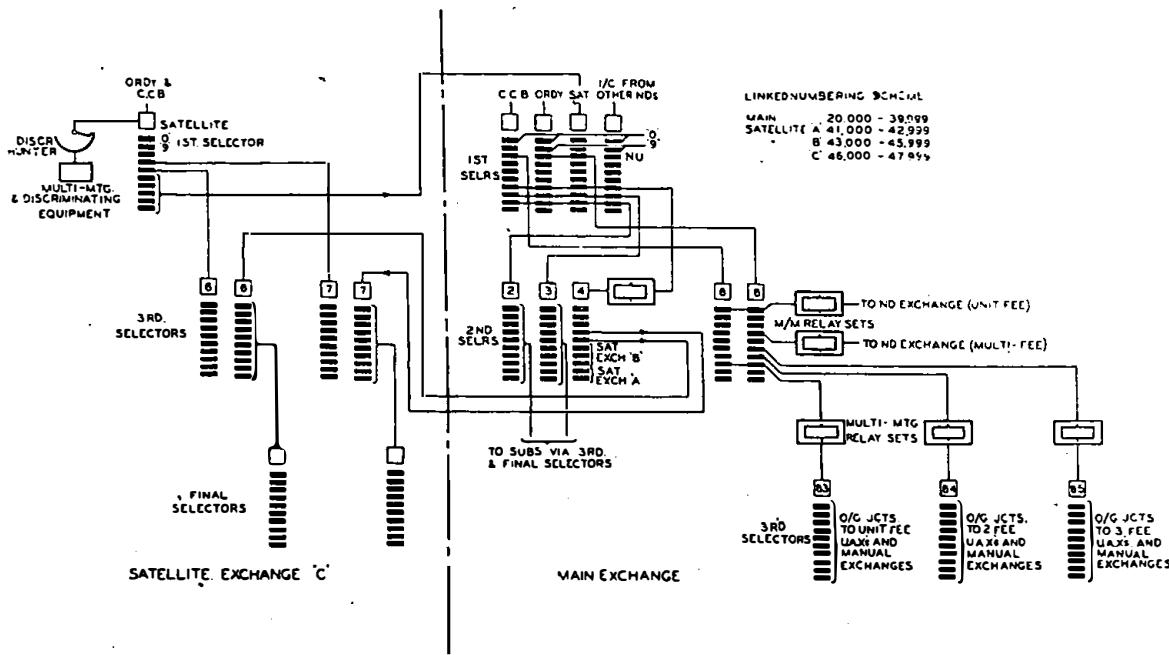

FIG. 1.—TYPICAL TRUNKING ARRANGEMENTS.

discriminator provides for discrimination when the codes for exchanges in the multi-fee area are dialed, and causes the subscriber's meter to be operated, the appropriate number of times, when the called subscriber answers.

**Trunking Arrangements.**

Typical trunking arrangements are shown in Fig. 1. The same numbering scheme as that used in Fig. 3 of F. Wilson and G. R. Sudell's article has been employed.

On routes outgoing from the main exchange to other non-director exchanges, the auto-auto relay sets are fitted on the junctions. 2nd selector levels, and therefore 2-digit codes, are used for the larger routes. U.A.X.'s and small manual exchanges are grouped according to their fees on the levels of 3rd selectors, i.e., a separate group of 3rd selectors is provided for each fee. This permits the auto-auto relay sets to be fitted between the 2nd and 3rd selectors and reduces the number of relay sets required.

On routes incoming from other non-director areas, the incoming selectors have the multi-metering level connected to N.U. tone to prevent a distant sub-

be the same as the route fee, i.e., the fee between the two main exchanges. Where there are these fee differences, calls to the satellite exchanges concerned will be treated as tandem calls and will be handled manually. Subscribers can be instructed to dial "0" for such calls, as satellite exchanges with their own charge lists always have individual names.

Coin box users are instructed to dial only to automatic exchanges within unit fee. They are prevented from dialing beyond the unit fee area at the main exchange by connecting N.U. tone to the multi-fee levels of the coin box group of 2nd selectors and at satellite exchanges by discrimination in the satellite exchange discriminator.

The number of codes available with the scheme herein described is the same as with the original scheme, i.e., 100 3-digit codes or their equivalent in 2-digit codes. (In both schemes the use of a 2-digit code results, of course, in the loss of 10 3-digit codes.)

Should it be decided to cater for tandem dialling to indirectly connected exchanges, the discriminating equipment fitted on a 2nd selector level will provide for 100 4-digit codes—with the loss of 10 3-digit

ones. The total code capacity would thus be 190, comprising 90 3-digit codes and 100 4-digit ones.

*Circuit Arrangements of Multi-Metering Relay Sets.*

The circuit of a multi-metering relay set is shown in Fig. 2. Essentially the relay set gives the same facilities as those given by the standard auto-auto relay set used on junctions between a main exchange

the number of calls completed automatically by subscribers. Hitherto this has been obtained in non-director areas by a summation of the readings of the subscribers' meters, as all calls completed automatically were unit fee calls. Under multi-metering conditions, however, this summation will not give the total number of calls but the total units at which the calls were metered. It is necessary,

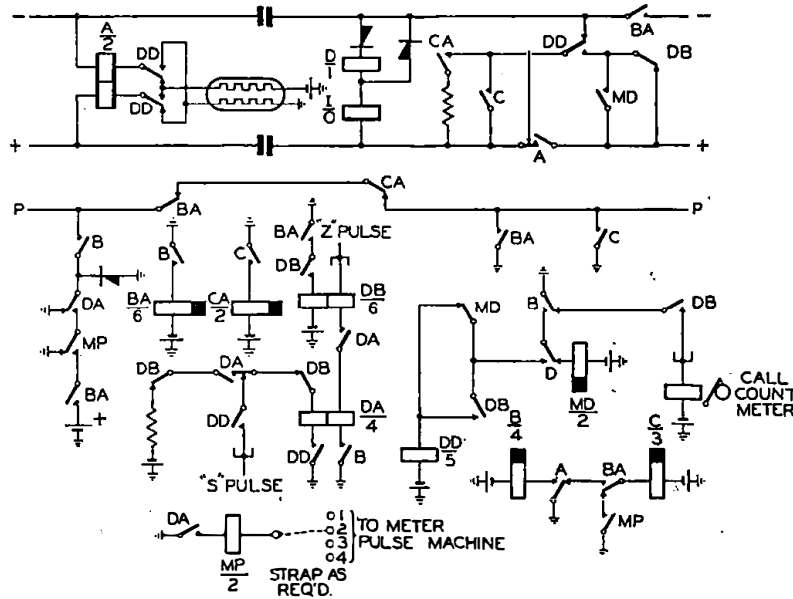

FIG. 2.—AUTO-AUTO RELAY SET WITH MULTI-METERING.

and its satellite, but with facilities for strapping to cause metering to be effected at 1, 2, 3 or 4 units as required. The requisite metering pulses, under the control of S and Z pulses, are obtained from a standard meter pulse machine as used at director exchanges. The relay set is used only on calls from subscribers and accordingly it does not cater for the repetition of busy flash which, of course, is useful only to operators. The multi-metering relay set includes an impulse regenerator when the resistances of the junctions are such as to require regeneration of the dialled impulses.

For statistical purposes it is necessary to know

therefore, to provide counting meters in association with the relay sets on the multi-metering level to determine the total number of units at which the multi-fee calls were metered and to use this figure to reduce the grand total of the subscribers' meter readings from units to calls.

*Conclusion.*

The scheme described in this article provides means for dealing with the large majority of multi-fee traffic originated by non-director subscribers by using equipment that is little more complicated than that required for unit fee traffic.

# A Simple D.C. Method for Identifying Cables

U.D.C. 621.315.232 : 621.317.44

**B**EFORE the diversion or repair of a cable is undertaken it is, of course, necessary to confirm the identity of the cable. This may be difficult when the cable is lying among several externally identical cables. It is also particularly important in multi-tube coaxial cables, to be able to distinguish the particular tube concerned. The outer

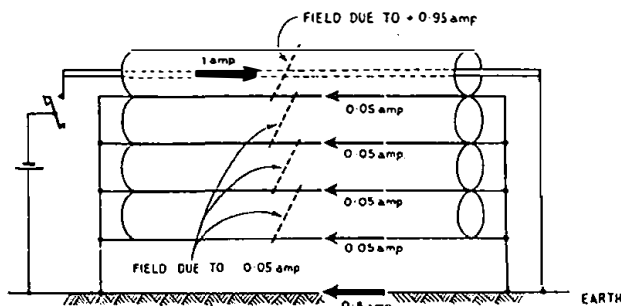

FIG. 1.—DIAGRAM ILLUSTRATING CURRENT FLOW.

conductors are all similar, and, being in metallic contact throughout, cannot be "marked" by battery, or distinguished by an audio frequency test using the probe tester (S.A. 9003).

A satisfactory and simple method to achieve identification is to connect an earthed battery to the centre or a selected conductor within the required cable at a terminal station; this conductor is earthed at the far end. The current flowing in the inner conductor is divided on its return between the earth and all the cable sheaths on the route, as shown in Fig. 1. Most of the return current usually flows in the earth, and the current in the inner conductor therefore greatly preponderates over that in its own surrounding sheath. The magnetic field due to this current can, therefore, be detected at any manhole on the route without opening any of the cables or coaxial tubes.

As shown in Fig. 2 a closed iron core, bearing a coil, is arranged to be hinged so that it can close around the cable or coaxial tube being tested; the coil is connected to a sensitive moving-coil galvanometer. The direct current is keyed very slowly while the iron core is closed around each cable in the route, in turn, and the galvanometer observed for one minute. When the iron core is around the "wanted" cable, deflections result which are associated with each "make" and "break" in the current; no noticeable deflections result on the other cables.

In an actual test on the London-Birmingham 4-tube coaxial cable (two tubes were working with power on and could not be interrupted) 0.8 A was

passed between stations eight miles apart, and momentary scale deflections of about 1 cm. were obtained when the core was around the coaxial tube required to be identified. This deflection was the result of a current surge in the galvanometer circuit; calculation shows a maximum value of 150 mA attained in  $1 \mu\text{S}$  with a tail lasting 100 mS. The iron core and coil used were part of a Ferranti standard 0-10-50 A size clip-on ammeter, and the galvanometer was of the portable Tinsley differential reflecting type (Post Office No. 27A).

This method of identifying one of a group of lead sheathed cables is capable of being utilised on coaxial, balanced-pair or any other type of cable. The results are not seriously affected by light armouring; insulating gaps in the sheath have no effect. Ordinary pairs, screened pairs and wires within cables can also be identified if necessary. The method has an im-

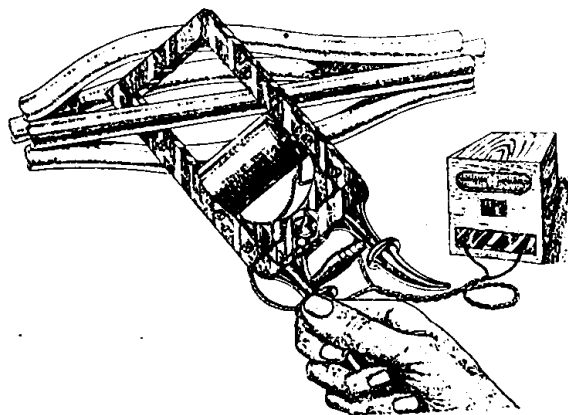

FIG. 2.—METHOD OF TEST

portant application when submarine cables are repaired at sea, although a more sensitive detector than has been described would be required because of the very heavy armouring wires. It has been the practice of the Post Office Cable Ships to carry a "Scissors-type Cable Detector" to check whether the cable picked-up is working and carrying D.C. telegraphs or other L.F. signals. A two-valve amplifier is associated with a robust design of clip-on core. Although the accuracy of navigation now possible with radio aids is very high this device is well worth using especially in areas where a large number of cables of similar armouring are close together, or where cables are liable to movement, in view of the additional confidence obtained that the correct cable is being cut.

J. P.

## Notes and Comments

### Roll of Honour

The Board of Editors deeply regrets to have to record the deaths of the following members of the Engineering Department :—

*While serving with the Armed Forces.*

Aberdeen Telephone Area ..	Montgomery, J. S.	Skilled Workman, Class II ..	Signalman, Royal Signals
Belfast Telephone Area ..	George, D. B. ..	Unestablished Skilled Workman	Flight Sergeant, R.A.F.
Birmingham Telephone Area	Beck, J. T. ..	Skilled Workman, Class I ..	L/Sergeant, Royal Signals
Blackburn Telephone Area ..	Ball, T. B. ..	Unestablished Skilled Workman	Corporal, Royal Signals
Bournemouth Telephone Area	Windus, E. ..	Unestablished Skilled Workman	Flight Sergeant, R.A.F.
Bradford Telephone Area ..	Moran, S. ..	Skilled Workman, Class II ..	L/Corporal, Royal Signals
Bradford Telephone Area ..	Redman, J. M. ..	Unestablished Skilled Workman	Signalman, Royal Signals
Brighton Telephone Area ..	Browne, W. J. ..	Skilled Workman, Class II ..	C.Q.M.S., R.A.S.C.
Brighton Telephone Area ..	Muggeridge, D. W.	Skilled Workman, Class II ..	Flight Sergeant, R.A.F.
Canterbury Telephone Area	Dean, W. T. ..	Unestablished Skilled Workman	Sergeant, R.A.F.
Canterbury Telephone Area	Patterson, A. F.	Labourer .. ..	Stoker Petty Officer, R.N.
Edinburgh Telephone Area..	Burnett, S. A. W.	Skilled Workman, Class II ..	L/Corporal, Royal Signals
Engineering Department ..	Aylett, C. H. ..	Clerical Officer .. ..	Driver, R.A.S.C.
Engineering Department ..	Gilbert, J. G. ..	Clerical Officer .. ..	Signalman, Royal Signals
Engineering Department ..	Jones, D. D. ..	Mechanic .. ..	Sergeant, R.A.F.
Engineering Department ..	Jones, J. A. ..	Adult Messenger .. ..	Stoker, 1st. Class, R.N.
Engineering Department ..	Welch, H. ..	Motor Cleaner .. ..	Lance Bombardier, Royal Artillery
Engineering Department ..	Wilde, G. M. ..	Mechanic .. ..	Corporal, R.A.F.
Glasgow Telephone Area ..	Griffin, G. ..	Unestablished Skilled Workman	L/Corporal, Royal Signals
Glasgow Telephone Area ..	Lawson, A. ..	Unestablished Skilled Workman	Signalman, Royal Signals
Glasgow Telephone Area ..	McClymont, H. M.	Skilled Workman, Class II ..	Flight Sergeant, R.A.F.
Gloucester Telephone Area..	Moulden, E. H. ..	Unestablished Skilled Workman	Flight Sergeant, R.A.F.
Guildford Telephone Area..	Jones, N. G. ..	Clerical Officer .. ..	Aircraftsman, Class II, R.A.F.
Leeds Telephone Area ..	Wood, T. A. ..	Unestablished Skilled Workman	Signalman, Royal Signals
Leicester Telephone Area ..	Ireland, P. ..	Skilled Workman, Class I ..	Flying Officer, R.A.F.
Lincoln Telephone Area ..	Bradley, H. ..	Skilled Workman, Class II ..	Signalman, Royal Signals
Liverpool Telephone Area ..	Dixon, J. F. ..	Tradesman .. ..	Gunner, Royal Artillery
Liverpool Telephone Area ..	Morton, C. G. ..	Unestablished Skilled Workman	Flight Sergeant, R.A.F.
London Telecommunications Region	Barrett, G. F. ..	Inspector .. ..	Captain, Royal Signals
London Telecommunications Region	Bouchard, H. R.	Unestablished Skilled Workman	Sub. Lieutenant, Fleet Air Arm, R.N.
London Telecommunications Region	Boys, J. R. ..	Unestablished Skilled Workman	Able Seaman, R.N.
London Telecommunications Region	Bristow, F. G. ..	Unestablished Skilled Workman	Signalman, Royal Signals
London Telecommunications Region	Cameron, C. S. ..	Unestablished Skilled Workman	Flight Sergeant, R.A.F.
London Telecommunications Region	Carr, S. R. ..	Unestablished Skilled Workman	Signalman, Royal Signals
London Telecommunications Region	Dorkins, H. G. ..	Skilled Workman, Class I ..	Corporal, Royal Signals
London Telecommunications Region	Farrance, D. A. ..	Unestablished Skilled Workman	Signalman, Royal Signals
London Telecommunications Region	Hill, B. ..	Unestablished Skilled Workman	Lance Corporal, Royal Signals
London Telecommunications Region	Howard, L. A. M.	Unestablished Skilled Workman	Signalman, Royal Signals
London Telecommunications Region	Howes, W. F. ..	Skilled Workman, Class II ..	Signalman, Royal Signals
London Telecommunications Region	Mayhew, H. J. ..	Unestablished Skilled Workman	Lance Bombardier, Royal Artillery
London Telecommunications Region	Mears, J. R. ..	Skilled Workman, Class II ..	Flight Sergeant, R.A.F.

London Telecommunications Region	Miller, H. E.	..	Skilled Workman, Class II	..	Flight Lieutenant, R.A.F.
London Telecommunications Region	Nash, G. E.	..	Unestablished Skilled Workman		Corporal, Royal Signals
London Telecommunications Region	Pearson, N. C.	..	Unestablished Skilled Workman		Signalman, Royal Signals
London Telecommunications Region	Perry, R. C.	..	Skilled Workman, Class II	..	Signalman, Royal Signals
London Telecommunications Region	Pulham, J. W. C.		Unestablished Skilled Workman		Flight Sergeant, R.A.F.
London Telecommunications Region	Wright, W. G.	..	Unestablished Skilled Workman		Sergeant, Beds. & Herts. Regt.
Newcastle - on - Tyne Telephone Area	Edmondson, J. P.		Unestablished Skilled Workman		Sergeant, R.A.F.
Nottingham Telephone Area	Ellis, J. C. H.	..	Skilled Workman, Class II	..	L/Corporal, Royal Signals
Peterborough Telephone Area	Gill, J. A.	..	Unestablished Skilled Workman		Signalman, Royal Signals
Portsmouth Telephone Area	Jones, D. R.	..	Unestablished Skilled Workman		Sergeant, R.A.F.
Preston Telephone Area	Kay, J.	..	Unestablished Skilled Workman		Signalman, Royal Signals
Scotland West Telephone Area	Bell, W.	..	Skilled Workman, Class II	..	Signalman, Royal Signals
Scotland West Telephone Area	Graham, A. S.	..	Skilled Workman, Class II	..	Lance Corporal, Royal Signals
Scotland West Telephone Area	McGuire, J.	..	Unestablished Skilled Workman		Gunner, Royal Artillery
Scotland West Telephone Area	McMinn, G. F.	..	Unestablished Skilled Workman		Signalman, Royal Signals
Scotland West Telephone Area	Reid, E.	..	Unestablished Skilled Workman		Signalman, Royal Signals
Sheffield Telephone Area	Bateman, F. J.	..	Clerical Officer	..	Corporal, Royal Signals
Sheffield Telephone Area	Cowen, H.	..	Skilled Workman, Class II	..	Signalman, Royal Signals
Sheffield Telephone Area	Jack, A. D.	..	Skilled Workman, Class II	..	Sergeant, R.A.F.
Sheffield Telephone Area	Usher, K., D.F.C.	..	Unestablished Skilled Workman		Flight Lieutenant, R.A.F.
South-Western Region	Bucklitsch, E. K. F.	..	Chief Inspector	..	Major, Royal Signals
Southampton Telephone Area	Spencer, A. J.	..	Unestablished Skilled Workman		Flight Lieutenant, R.A.F.
Stoke-on-Trent Telephone Area	Smith, H. V.	..	Skilled Workman, Class II	..	Lance Corporal, Hussars

### Recent Awards

The Board of Editors has learnt with great pleasure of the honours recently conferred upon the following members of the Engineering Department:—

*While serving with the Armed Forces.*

Birmingham Telephone Area	Daffron, T. J.	..	Skilled Workman, Class II	Sergeant, Royal Signals	British Empire Medal
Birmingham Telephone Area	Freeman, G.	..	Skilled Workman, Class II	Signalman, Royal Signals	Mentioned in Despatches
Birmingham Telephone Area	Gosling, J. C.	..	Skilled Workman, Class I	C.Q.M.S., Royal Signals	British Empire Medal
Birmingham Telephone Area	Hammond, A. G. W.	..	Inspector	Lieut. Col., Royal Signals	Officer of the Order of the British Empire and Mentioned in Despatches
Bradford Telephone Area	Crotty, T. C.	..	Skilled Workman, Class II.	Bombardier, R.A.	Military Medal
Bradford Telephone Area	Speechley, E.	..	Inspector	Major, Royal Signals	Member of the Order of the British Empire
Bristol Telephone Area	Newman, H. F. A. J.	..	Skilled Workman, Class II	Lieutenant, Royal Signals	Mentioned in Despatches
Cambridge Telephone Area	Allen, D. W.	..	Skilled Workman, Class I	Captain, Royal Signals	Member of the Order of the British Empire
Cambridge Telephone Area	Huggins, J. C.	..	Skilled Workman, Class II	R.Q.M.S., R.A.	Mentioned in Despatches



Canterbury Telephone Area	Walters, A. A. . .	Skilled Workman, Class II	Signalman, Royal Signals	Mentioned in Despatches
Chester Telephone Area . .	Davey, W. A. T.	Skilled Workman, Class II	Sergeant, Royal Signals	British Empire Medal and Mentioned in Despatches
Edinburgh Telephone Area . .	Allan, R. . .	Skilled Workman, Class I	Sergeant, Royal Signals	Mentioned in Despatches
Edinburgh Telephone Area . .	Hogart, J. F. . .	Skilled Workman, Class I	Lieutenant, Royal Signals	British Empire Medal
Edinburgh Telephone Area . .	Slater, W. . .	Skilled Workman, Class I	C.O.M.S., Royal Signals	Mentioned in Despatches
Edinburgh Telephone Area . .	Stevenson, H. C.	Assistant Engineer	Major, Royal Engineers	Member of the Order of the British Empire and Mentioned in Despatches
Engineering Department . .	Barnett, W. J. G., M.B.E.	Inspector . .	Major, Royal Signals	Croix-de-Guerre with Silver-Gilt Star
Engineering Department . .	Biddlecombe, C.	Skilled Workman, Class I	Sergeant, Royal Signals	Mentioned in Despatches
Engineering Department . .	Brookes, A. A.	Assistant Photo- printer	Lieutenant, R.A.S.C.	Mentioned in Despatches
Engineering Department . .	Carr, H. . .	Motor Cleaner . .	Corporal, R.A.C.	Mentioned in Despatches
Engineering Department . .	Cheyney, C. E. . .	Inspector . .	Major, Royal Signals	American Bronze Star
Engineering Department . .	Coates, G. H. . .	Executive Engineer	Major, Royal Signals	Member of the Order of the British Empire
Engineering Department . .	Croisdall, A. C.	Inspector . .	Major, Royal Signals	Member of the Order of the British Empire
Engineering Department . .	Dean, C. . .	Skilled Workman, Class I	Flying Officer, R.A.F.	Distinguished Flying Cross
Engineering Department . .	Dibsdale, A. T. D.	Inspector . .	Major, Royal Signals	Mentioned in Despatches
Engineering Department . .	Franklin, R. H.	Asst. Staff Engineer	Major, Royal Signals	Mentioned in Despatches
Engineering Department . .	Garnett, W. H. . .	Inspector . .	Wing Commander, R.A.F.	Officer of the Order of the British Empire, American Bronze Star and Mentioned in Despatches
Engineering Department . .	Godwin, R. . .	Motor Mechanic . .	Sergeant, Queens Bays	Distinguished Service Medal
Engineering Department . .	Hankin, B. D. . .	Inspector . .	Major, Royal Signals	Mentioned in Despatches
Engineering Department . .	Harper, S. D. . .	Assistant Engineer	Lieut. Commander, R.N.	Mentioned in Despatches
Engineering Department . .	Langfield, F. J.	Clerical Officer	Cadet Officer, Royal Signals	Mentioned in Despatches
Engineering Department . .	Leckenby, A. J., M.B.E.	Executive Engineer	Major, Royal Signals	Croix-de-Guerre with Silver-Gilt Star
Engineering Department . .	Mitchell, M. . .	Inspector . .	Lieut. Colonel, Royal Signals	Member of the Order of the British Empire

Engineering Department ..	Morgan, J. L. W.	Inspector ..	Major, Royal Signals	Member of the Order of the British Empire
Engineering Department ..	McDonald, A. G., T.D.	Chief Motor Transport Officer	Colonel, R.E.M.E.	Officer of the Order of the British Empire
Glasgow Telephone Area ..	Jeffrey, D. C. ..	Skilled Workman, Class II	Captain, Royal Signals	Member of the Order of the British Empire and Mentioned in Despatches
Lancaster Telephone Area ..	Bushby, J. H. ..	Skilled Workman, Class II	Warrant Officer, R.A.F.	Distinguished Flying Cross
Leicester Telephone Area ..	Gargrave, C. C.	Skilled Workman, Class II	Major, N. Staffs Regt.	Mentioned in Despatches
Liverpool Telephone Area ..	Ferguson, A. W.	Skilled Workman, Class II	L/Sergeant, Royal Signals	Military Medal
London Telecommunications Region	Battles, J. P. ..	Labourer ..	Sergeant, R.A.C.	Military Medal
London Telecommunications Region	Clarke, R. W. ..	Inspector ..	Captain, Royal Signals	Mentioned in Despatches
London Telecommunications Region	Dawson, E. D.	Skilled Workman, Class II	Corporal, R.A.F.	Mentioned in Despatches
London Telecommunications Region	Gardiner, R. J.	Skilled Workman, Class II	Sergeant, R.A.F.	Mentioned in Despatches
London Telecommunications Region	Harrod, J. T., M.M.	Skilled Workman, Class I	Captain, Royal Signals	Member of the Order of the British Empire
London Telecommunications Region	Hudson, J. B. ..	Skilled Workman, Class II	Lance Corporal, Royal Signals	Mentioned in Despatches
London Telecommunications Region	Jennings, W. F.	Skilled Workman, Class II	Corporal, Royal Signals	Military Medal
London Telecommunications Region	Jessop, J. P. ..	Skilled Workman, Class II	L/Corporal, Royal Signals	Mentioned in Despatches
London Telecommunications Region	Jones, R. E. ..	Executive Engineer	Lt. Col., Royal Signals	American Bronze Star
London Telecommunications Region	Pocock, D. G. ..	Assistant Engineer	Major, Royal Signals	Mentioned in Despatches
London Telecommunications Region	Searle, H. R. ..	Skilled Workman, Class II	Flying Officer, R.A.F.	Distinguished Flying Cross
London Telecommunications Region	Thomas, D. R. W.	Skilled Workman, Class II	Major, Royal Signals	Member of the Order of the British Empire and Mentioned in Despatches
Manchester Telephone Area	Crook, F. ..	Skilled Workman, Class II	C.Q.M.S., Royal Signals	British Empire Medal and Mentioned in Despatches
Manchester Telephone Area	Moore, J. ..	Skilled Workman, Class II	Sergeant, Royal Signals	Mentioned in Despatches
Midland Region Headquarters	Grieve, J. W. ..	Inspector ..	Major, Royal Signals	Mentioned in Despatches
Newcastle-on-Tyne Telephone Area	Sedgwick, V. H.	Skilled Workman, Class II	Wt. Offr., Class II., Royal Signals	Member of the Order of the British Empire
Northern Ireland Region ..	Sommerville, H. B.	Chief Engineer ..	Colonel, Royal Signals	Officer of the Order of the British Empire
Norwich Telephone Area ..	Oliver, W. L. ..	Skilled Workman, Class I	Sergeant, R.A.F.	Mentioned in Despatches
Scottish Region ..	Watt, J. P. ..	Inspector ..	Major, Royal Signals	Member of the Order of the British Empire

Sheffield Telephone Area ..	*Usher, K ..	Unestablished Skilled Workman	Flight Lieutenant, R.A.F.	Distinguished Flying Cross
Shrewsbury Telephone Area	Cook, J. ..	Unestablished Skilled Workman	Flying Officer, R.A.F.	Distinguished Flying Medal
Shrewsbury Telephone Area	Statham, H. W.	Skilled Workman, Class I	Sergeant, Royal Signals	Mentioned in Despatches

\* The announcement of Mr. Usher's death appears in the Roll of Honour in this issue.

### New Year Honours

In addition to awards to Engineering Department personnel serving with the Armed Forces which are included in the above list the Board of Editors was pleased to note that the New Year Honours List included the following honours to members of the Department serving in a civilian capacity:—

Chester Telephone Area ..	Capner, C. L. (Miss) ..	Female Assistant, Grade I ..	British Empire Medal
Engineering Department ..	Coopersmith, M. ..	Inspector .. ..	British Empire Medal
Engineering Department ..	Firmin, E. W. ..	Submarine Superintendent ..	Officer of the Order of the British Empire
Engineering Department ..	Mumford, A. H. ..	Staff Engineer .. ..	Officer of the Order of the British Empire
Engineering Department ..	Radley, W. G. ..	Controller of Research ..	Commander of the Order of the British Empire
Engineering Department ..	Rhodes, J. .. ..	Executive Engineer .. ..	Member of the Order of the British Empire
Guildford Telephone Area ..	Moody, M. F. (Mrs.) ..	Female Assistant, Grade I ..	British Empire Medal
H.M.F.S. <i>iris</i> .. ..	Smith, W. N. ..	Wireless Telegraphist ..	British Empire Medal
Home Counties Region ..	Nye, E. W. .. ..	Inspector .. ..	British Empire Medal
Home Counties Region ..	Waters, F. J. ..	Skilled Workman, Class I ..	British Empire Medal
London Telecommunications Region	Adams, W. ..	Skilled Workman, Class I ..	British Empire Medal
London Telecommunications Region	Bunker, T. .. ..	Skilled Workman, Class I ..	British Empire Medal
London Telecommunications Region	Gauld, L. L. E. (Mrs.)	Female Assistant, Grade I ..	British Empire Medal
North-Eastern Region ..	Windass, E. S. ..	Skilled Workman, Class II ..	British Empire Medal
North-Western Region ..	Quest, I. S. K. ..	Skilled Workman, Class I ..	British Empire Medal
Preston Telephone Area ..	Campsey, M. E. (Miss)	Female Assistant, Grade I ..	British Empire Medal
Scottish Region .. ..	Johnston, F. S. ..	Skilled Workman, Class II ..	British Empire Medal
Sheffield Telephone Area ..	Ascombe, M. E. (Mrs.)	Female Assistant, Grade I ..	British Empire Medal
South-Western Region ..	Shaw, J. .. ..	Chief Inspector .. ..	British Empire Medal
Southampton Telephone Area	Yeatman, H. G. ..	Chief Inspector .. ..	Member of the Order of the British Empire
Welsh and B.C. Region ..	Smith, H. T. ..	Skilled Workman, Class I ..	British Empire Medal

The Board was also pleased to note the inclusion in the list of a number of members of the telecommunications industry, among whom were:—

Mr. T. G. Spencer (S.T.C.) and Mr. F. J. E. Brake (Creeds) on whom knighthoods were conferred; Mr. J. C. Wade (G.E.C.), who received the O.B.E.; and Messrs. J. G. Flint (T.M.C.), W. H. Grinsted (Siemens Bros.), P. B. Healey (T.M.C.), V. T. Jones (A.T.E.), G. R. Polgreen (S.E.I.), E. A. Richards (S.T.C.), M. Smith (Ericssons), and E. S. Wright (S.T.C.), who were awarded the M.B.E.

### Col. J. Reading

The Board of Editors offers its congratulations to Col. J. Reading who, on return from the Army, has been promoted to Staff Engineer. Col. Reading

takes charge of the Equipment Branch of the Engineer-in-Chief's Office in succession to Mr. H. G. S. Peck, who has transferred to the Efficiency and Organisation Branch.

Col. Reading has also resumed his duties as Secretary of the Institution of Post Office Electrical Engineers, but has relinquished his post of Managing Editor of the *P.O.E.E. Journal*.

### Errata

In Part IV of the article on Crystal Filters, published in the October, 1945, issue of this JOURNAL, the following errors occurred:—

Page 78. In Fig. 7 (d)  $2C_3$  should read  $C_1 + 2C_3$ .

Page 79. In Fig 10 (d)  $L=L_1=L_2$  should read  $L=L_0=L_1$ .

# Regional Notes

## London Telecommunications Region

### LONDON TRUNK—TOLL B AUTO NETWORK.

The development of dialling over trunk lines has produced a new maintenance problem, viz., that of ensuring that the local automatic networks are maintained to a degree that will ensure efficient operation with distant calling centres.

The London Trunk Auto Fault Control has to accept faults from the following:—

- (1) 2 V.F. engineering staff (the 2 V.F. fault maintenance officer accepts faults on incoming trunks from the distant zone engineering staff and when proved clear of the 2 V.F. apparatus passes the fault to the auto fault control. The auto maintenance staff are responsible for the first code and subsequent switches).
- (2) Toll B testing telephonist (faults from exchanges in the toll area controlled by London).
- (3) Trunk testing telephonist (faults on manual board first code selectors).
- (4) Engineering staff at distant group automatic exchanges in the toll area, who control their own outgoing lines (viz., Slough and Hertford).
- (5) Engineering staff at all local exchanges where incoming lines terminate (chiefly permanent glow faults on incoming lines at local exchanges).

A central auto fault control has been established to accept these faults from the various groups. Faults accepted are dealt with as in normal automatic exchanges.

The difficulties which have been encountered are:—

- (1) Approximately 50 per cent. of the faults cleared are proved to exist at the called exchanges. This, employing the normal fault procedure of an automatic exchange, would mean that trunk and toll lines have to be held for trace, to enable faults to be cleared in the local exchanges.
- (2) All faults on first code selectors and relay sets must receive immediate attention, for until the fault is cleared a trunk or toll circuit is out of service.
- (3) The common apparatus, A digit switches and directors, must be maintained at a very high standard to offset loss of margin due to line distortion.
- (4) When a fault occurs on any common piece of apparatus, faults are received from all sources, as all the traffic originates from manual boards. This results in a greater number of registered faults being reported as compared with a local exchange of the same capacity, and produce peak periods on the fault control.
- (5) There are three extended busy periods, in the morning, afternoon and evening. This reduces considerably the time available for normal routines.

These difficulties have been met by:—

- (1) More concentrated and frequent routines, particularly functional testing.
- (2) Continuous routine testing by selected operators, who pass test calls via manual board first code

switches, thus obviating the necessity of holding trunk and toll lines for trace. These operators are in direct communication with the engineering staff and concentrate on any level or group of circuits where difficulty is being experienced.

- (3) By the provision of a number of first code selectors wired to patching jacks so that when a first code selector has to be withdrawn from service for routine or replacement of worn parts, the line is connected to another switch until the original is again ready for service. (The first code switches are pre-2,000 type and therefore have to be re-adjusted whenever removed from their normal position.)
- (4) The use of modified 2,000-type box testers which ensure that the common apparatus operated with a high degree of efficiency and will respond to a 50/50 and 80/20 ratio impulse. (This has now been extended to other exchanges.)

G. A. A.

### LOCATION OF AN OBSCURE FAULT

The use of barretter resistors in the circuit of first code and final selectors has brought to notice a fault liability which is expensive from the maintenance point of view.

The fault which occurred was of an intermittent nature and was brought about by a 250 volt A.C. lighting circuit coming into contact with an exchange line. The subscriber's line equipment was operated and the first code selector seized. The 250 volts burned out the barretter in the first code selector in question, which dropped out. The subscriber's uni-selector then stepped on and a similar cycle of events occurred. If an incoming call happened to be in progress at the moment the fault came on, then the ballast resistor in the final selector would burn out. The faulty barretter resistors were not indicated by an alarm and could only be found out by testing. Replacement is not a simple matter. The maintenance staff called in the Special Investigation Inspector, who realised that something out of the ordinary was happening.

The first point considered was that neither the fuses nor protectors on the main frame were affected and although afterwards, when the faulty circuit was located, it was found the heat coils were slightly scorched, they were still operative and the offending circuit could not, therefore, be readily identified. A complete test of the subscribers' lines thought to be concerned failed to reveal the fault and an examination of the subscribers' cards did not help. It was then decided that a process of elimination was required, and the method adopted was as follows.

A number of subscribers' circuits was selected and the fuses on the main frame of these circuits were replaced by Resistors Barretter No. 1. An hourly inspection of the barretters on the main frame was made and after a short time the faulty circuit was definitely located and clearance of the actual fault was quite a simple matter. It is of interest to note that out of a total of 32 Resistors Barretter No. 1 burned out, 31 were destroyed before the barretters were placed on the main frame.

The method adopted was the only one that was readily available, but it is felt that a cheaper means could be equally effective, and consideration is being given to this point.

## Midland Region

### FLOOD DAMAGE, FEBRUARY, 1946.

*Stoke Area.*—The floods in North Staffordshire and South Cheshire, described locally as the worst in living memory, caused considerable damage to telephone plant in the Stoke-on-Trent Telephone Area.

The average annual rainfall for the area is 30 inches, but during the first nine days of February 4.47 inches fell, and during the 24 hours ending 9 a.m. on the 8th, the rainfall in the northern part of the area was 2.13 inches—the highest recorded since 1878.

The city of Stoke-on-Trent stands on high and hilly ground near the source of the river, and, except for local incidents, escaped the worst of the flood damage.

To the north, the ground falls steeply to the Cheshire plain, and drains into the River Weaver, which, owing to its low storage capacity and the already waterlogged nature of the ground, rose rapidly and flooded many towns and villages to a depth of several feet. The flooding was severe in Nantwich, and manholes which for years have been dry, were flooded, and unsuspected corrosion faults in many cables were thereby revealed. The heavy mud penetrated terminal blocks on D.P.'s, and also showed up cracks in aerial cable sheaths.

To the south, the Trent falls 600 feet in 10 miles and leaves the city boundary in a narrow valley at Tittensor. Here the full force of the flood waters was felt, and a road bridge carrying a spur to the Stoke-Stafford cable was carried completely away on the night of February 8th, the adjacent main road and main cable track being also undermined by the flood waters. Further down the valley, the road bridge over the Trent at Sandon disintegrated, and the junction cable to Sandon exchange was carried away.

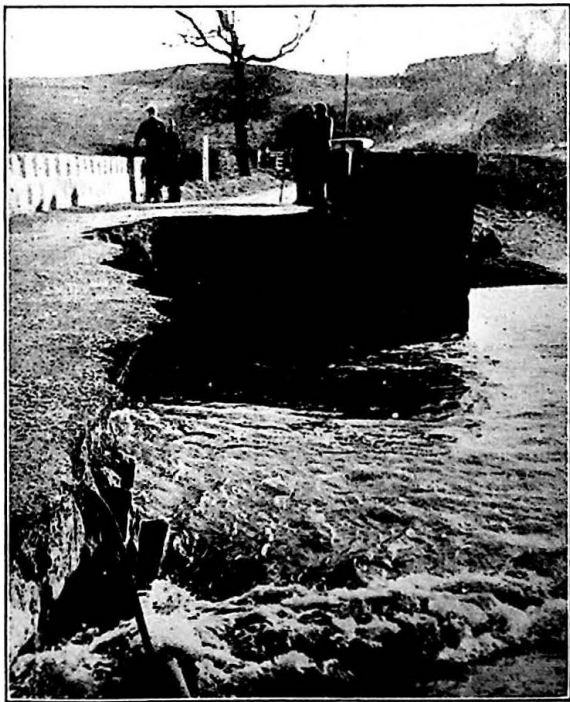

Photo: Staffordshire Chronicle.

ROAD BRIDGE OVER RIVER TRENT AT SANDON. P.O. JUNCTION CABLE, LEFT FOREGROUND.

In the southern portion of the area, Stafford stands on comparatively low ground and experienced serious flooding for four days. The lower part of the town and the railway station were continuously under water, but the main sorting office, which is adjacent to the railway station, escaped damage, except for the basements, which included a Works Order stores. The electricity supply was cut off and this affected both the telephone exchange and the sorting office. At the former a 2 kW emergency set maintained the service, and at the sorting and customs office an 8 kW, 240 V A.C. set was brought into use and coupled up to the main supply. At the worst period eight exchanges were isolated and approximately 1,000 subscribers' circuits affected. In addition to the flood damage, overhead wires and aerial cable were brought down by trees which had had their roots undermined, but the whole of the damage was repaired by the normal staff, with the assistance of Homelite and trailer pumps, within 10 days.

For some time many exchanges were inaccessible, due to flooded roads, and although water rose in cable chambers, no exchange plant suffered damage. The cables which were carried away with the bridges were replaced by temporary aerial cables, as it will be a long time before the bridges can be replaced.

N. V. K.

*Nottingham Area.*—The flood waters of the Trent reached Nottingham on Saturday, 9th February, and were at their height on the following morning. Many of the streets of West Bridgford on the south side of Trent Bridge were under water, and as a result, the main roads from Grantham, Leicester, Melton Mowbray and Loughborough which enter Nottingham from the south were for a time impassable.

At one time the town's electricity supply was threatened on account of the floods gaining access to the Wilford power station, and although Nottingham Central exchange and repeater station have their own standby plant, the satellite exchanges and the main Post Office buildings in the town would have been without light and power. A number of emergency generating sets at distant centres were earmarked for this possible emergency, but fortunately the threat did not materialise.

All the cable tracks and manholes in the flooded areas were inundated, and a number of cable faults resulted. Two trunk and two junction cables and some 2,000 subscriber's circuits were affected in Nottingham, mainly in West Bridgford, with a further 200 subscribers' circuits at Long Eaton.

The main factor giving rise to this damage was cracked cable sheaths. This was particularly so in the West Bridgford area, where some cables were faulty in as many as three places. This area, just south of Trent Bridge, suffered some bombing during the war, and it is probable that in many cases the damage was caused at that time, remaining undetected until the coming of the flood water.

Repairs were delayed on account of many of the manholes being submerged; the water also entered branch cables in inundated premises, and owing to the extended period of the flooding, had time to find its way into the joints of the main distribution cables. However, with the assistance of jointing parties loaned by the nearby telephone manager's areas, the bulk of the faults were cleared by the following week-end.

Some flood damage was also experienced at Matlock on the 8th February, when the Derwent overflowed and flooded the Town Square. Here a number of subscribers' cables were affected and service to 430 sub-

scribers was interrupted. The chief cause of the faults on these cables was sheath corrosion. Two days elapsed before the floods subsided sufficiently to gain access to the affected plant, but all the faults were rectified within six days.

Floods in surrounding areas caused faults on three junction and one trunk cables. W. C. W.

### Welsh and Border Counties Region

#### FLOOD INCIDENTS. SHREWSBURY AND CHESTER AREAS.

Very severe floods, reported to be the worst for nearly a century, affected the northern half of the Region during the period 8th to 10th February, 1946. Of a number of incidents, the following have been selected as of special interest.

The Ironbridge C.B.S.2 exchange is situated in a house facing the river Severn with a roadway between it and the river. This roadway became impassable for several days and on the 9th February water began to rise through the switchroom floor and it was evident that immediate steps would have to be taken to safeguard the equipment.

Access to the house was obtained by climbing over neighbouring property and the engineering staff decided that the switchboards should be raised 24 inches. Heavy stayblocks and planks were obtained and a platform built, upon which the switchboards and operators' chairs were placed. Relay sets, electricity meters and fuses were also raised and the work was completed by the time the water had reached a height of 17 inches above floor level and 7 inches from the top of the batteries.

Following the bursting of the banks of Bala lake and the flooding of the town, water commenced to enter the Bala C.B.S.2 exchange. In a short time the switchroom floor was under water and the N.F.S. and engineering staff were called out. Despite continuous pumping the water continued to rise rapidly and a foundation of bricks to support a plank platform was erected to raise the switchboard to ceiling height. Other equipment was also removed to a position above water level.

On the 8th February the emergency lineman was called out at 5 a.m. to Headquarters, Western Command, Chester. He found water to a depth of 18 in. in the apparatus room and 12 in. in the switchroom. The maintenance inspector, who arrived on the scene at 6 a.m., called on the N.F.S. for aid and also arranged for as much departmental pumping gear as

was available to be brought into use. At about 10 a.m. it was seen that the combined efforts were beginning to take effect, and by about mid-day the apparatus and switchroom were pumped and baled out. It was discovered that water had entered the apparatus room, which is at a lower level than the switchroom, via the Electricity Company's lead-in duct, and that this was caused by the failure of the main drain carrying surface water away to the River Dee to cope with the abnormal volume of water. No water entered via the Department's ducts. The extent of the damage in this incident was not very great; the wiring of some calling and clearing equipments was damaged, but was dried out during that day and the next. Several P.W.s were reported out of order the same morning, but these were due to local cable faults in the same vicinity.

Much of the work had to be carried out under conditions of extreme discomfort and in water knee deep, but the operating and engineering staffs by their continuous efforts to deal with the situation, were able to maintain service throughout the flood period.

H. C. A. I.

### North-Eastern Region

#### OLD WHITTINGTON EXCHANGE TRANSFER

The above C.B.S.1 exchange was transferred to automatic working on Saturday, 17th November, 1945.

The new exchange is of the standard non-director 2,000-type and is a satellite on Chesterfield automatic exchange. The old C.B.S. exchange has, therefore, lost its identity and the subscribers are included in the Chesterfield linked numbering scheme.

The equipment was installed by the A. T. & E. Co., and is the first of its kind in the country to utilise the new satellite 1st selector with an associated discriminator in place of the usual discriminating selector. Multi-metering facilities are provided and these will be used as soon as multi-metering can be introduced in the area and a regenerator is included in the discriminator circuit.

As Chesterfield is a Siemens No. 16 exchange, one of the features is the use of battery dialling over junctions, and, to enable standard equipment to work with it, relay sets were designed and installed at Chesterfield to convert leg to loop and loop to leg impulsion on the outgoing and incoming junctions respectively. These relay sets incorporate high speed relays and have proved satisfactory in operation.

W. N. B.

## Institution Notes

Recent additions to the Library include the following :

1667 *Radio Engineers' Handbook*.—F. E. Terman (American, 1943).

Summarises the body of engineering knowledge that is the basis of radio and electronics. Comprehensive and well documented it covers circuit elements and theory, vacuum tubes and electronics, vacuum tube amplifiers, oscillators, modulation and demodulation, power supply systems, radio transmitters and receivers, propagation of radio waves, antennas, radio aids to navigation, measurements.

1668 *Properties of Matter*.—Champion and Davy. (British, 1944.)

A book for the advanced student. Matter treated from a physical standpoint. Covers

units and dimensions, acceleration due to gravity, Newtonian constant of gravitation, elasticity, compressibility of solids and liquids, seismic waves, capillarity, surface films, kinetic theory of matter—osmotic pressure, diffusion, viscosity, errors of measurement, methods of determining Planck's constant.

1669 *The Universe Around Us*.—Sir James Jeans. (British, 1944.)

An account written in simple language intelligible to readers without special scientific knowledge, of the methods and results of modern astronomical research both observational and theoretical. Completely revised following the latest discoveries of knowledge of atomic nuclei.

- 1670 Modern Industrial Lighting.—G. B. Hughes. (British, 1945.)  
Designed specially to co-ordinate facts on the most recent discoveries in industrial researches on lighting. Requirements of new Factory Lighting Regulations. Covers maintenance, electrical wiring, recommended minimum operating foot candles and right use of backgrounds.
- 1671 Photographic Optics.—A. Cox. (British, 1945.)  
Deals thoroughly with optics of photography in language which the ordinary photographer can understand.
- 1672 Institution of Electrical Engineers: Associate Membership Examination Papers—May, 1945.
- 1673 Electron Diffraction.—R. Beeching. (British, 1936.)  
Covers wave properties of the electron and the crystal as a grating, diffraction by transmission through thin films, diffraction by reflection, apparatus and technique and applications.
- 1674 Electro-mechanical Transducers and Wave Filters. W. P. Mason. (American, 1942.)  
Contains fundamental analogies and inter-connections between electrical theory and mechanical theory. Its scope covers electrical network theory, application of network theory to lumped mechanical systems, acoustic equations and networks, vibration of membranes and plates, electromechanical converting systems, designs of electromechanical systems, application of electromechanical impedance elements in electrical wave filters.
- 1675 University of London.—B.Sc. Engineering Internal Examination Papers—June, 1945.
- 1676 University of London.—B.Sc. Engineering External Examination Papers—July, 1945.
- 1677 University of London.—Inter Engineering Internal Examination Papers—June, 1945.
- 1678 Electronic Equipment and Accessories.—R. C. Walker. (British, 1945.)  
Concise introduction to principles of electronics and their applications in industry for those who have acquired the elements of electricity and magnetism but who are not specialists in the use or design of electronics apparatus. Covers thermionic valves, fundamental characteristics and applications. Gas-filled valves and application, application of thermionic valves, light sensitive devices and methods of applying light cells, cathode ray tube, fundamental principles and methods of use. Miscellaneous electronic devices, small switchgear, delayed action devices, impulse recording or counting, miscellaneous circuit accessories.
- 1679 List of Post Office Green Papers.
- 1680 University of London.—Inter Engineering External Examination Papers—November, 1945.
- 1681 The Technique of Radio Design.—Zepler. (British, 1945.)  
A practical guide to development and testing of radio receiving apparatus of all types. Complicated mathematics avoided.
- 1682 Photography in Engineering.—C. H. S. Tupholme. (British, 1945.)  
Photographic technique in engineering described and well illustrated.
- 1683 Radio Designers' Handbook.—Edited by Langford Smith. (Australian, 1945.)  
Prepared expressly for the radio set designer. Covers audio and radio frequencies, rectification, filtering, hum, receiver components, tests and measurements, valve characteristics and general theory.

## Junior Section Notes

### Salisbury Centre

The session 1945-1946 has seen the Salisbury Centre stronger than ever before, and several novel meetings have been held on an inter-centre basis with the adjoining centres of Bournemouth and Southampton in the form of a "Quiz" or "Bee."

With the Southampton Centre home and away meetings were held; but with Bournemouth, due to transport difficulties, the joint meetings took the form of an "Inter-Area Call," similar to the B.B.C. "Trans-Atlantic Call." This was achieved by using amplified, equalised carrier cable pairs between Salisbury and Bournemouth and public address equipment at either end.

It is hoped that during the next session further meetings of this type may be held with centres further afield, because, due to the wide range of questions covered, the interest is greater and much can be learnt by all.

Secretaries of other local centres who are interested in this form of meeting are invited to contact the Salisbury local centre.

Normal papers by members have been enjoyed at

other meetings, which have been interspersed with visits to outside undertakings of interest.

N. H. R. Y.

### 1945-46 Sessions

Successful sessions have been reported by the following local centre secretaries. All are looking forward to the 1946-47 session and would like to hear from prospective members and members willing to contribute a paper or open a discussion.

Darlington—C. W. Hitchinson.

Derby—W. A. Mead.

Grimsby—C. S. Green.

London—E. L. Tickner.

London (Long Distance)—F. J. Mutter.

Maidstone—F. P. Walland.

Manchester—E. G. Owen.

Middlesbrough—W. E. Torbet.

Norwich—E. W. Mason.

Rochdale—N. Leach.

Salisbury—N. H. R. Yeate.

Shrewsbury—Ed. Jones.

Swansea—L. Gray.

# Staff Changes.

## Promotions

Name	Region	Date	Name	Region	Date
<i>Asst. Staff Engr. to Staff Engr.</i>			<i>Insp. to Chief Insp.—continued</i>		
Reading, J. ..	E.-in-C.O. ..	1.1.46	Bailey, E. A. ..	L.T.R. ..	8.6.45
<i>Asst. Engr. to Asst. Insp.</i>			Goulden, C. J. ..	N.W. Reg. ..	21.11.45
Billington, R.M. ..	E.-in-C.O. to W.T.S.	2.9.45	Gooch, J. V. L. ..	L.T.R. ..	1.1.46
<i>Insp. to Chief Insp.</i>			<i>Insp. to A.T.S.</i>		
Phipps, G. R. ..	L.T.R. ..	24.9.45	Parr, F. D. ..	E.-in-C.O. to H.C. Reg.	5.12.45
Andrewartha, C. J. ..	L.T.R. ..	19.9.45	<i>S.W.I. to Insp.</i>		
Clark, E. A. ..	N.E. Reg. ..	12.10.45	Baird, D. W. G. ..	Scot. Reg. to E.-in-C.O.	1.2.46
Fox, J. ..	N.E. Reg. ..	1.1.46	Yeo, B. F. ..	S.W. Reg. to E.-in-C.O.	1.2.46
Johnston, T. D. ..	Scot. Reg. ..	23.9.45	Broomfield, C. T. ..	E.-in-C.O. ..	17.11.45
Malyon, J. ..	H.C. Reg. ..	1.10.45	Deag, J. R. W. G. ..	E.-in-C.O. ..	29.12.45
Hood, J. B. ..	Mid. Reg. ..	5.11.45	<i>Draughtsman, Class I, to Senior Draughtsman</i>		
Lamping, C. T. ..	Mid. Reg. to E.-in-C.O.	25.11.45	Dickson, J. A. ..	N.W. Reg. ..	1.1.46
Cooper, H. L. ..	H.C. Reg. ..	27.1.46			

## Retirements

Name	Region	Date	Name	Region	Date
<i>Asst. Staff Engr.</i>			<i>Chief Insp.</i>		
Smith, H. A. ...	E.-in-C.O. ..	31.12.45	Minns, R. W. ..	W. & B.C. Reg.	17.12.45
Harding, R. W. ..	E.-in-C.O. ..	31.12.45	Clyma, H. P. ...	Mid. Reg. ..	31.12.45
Rumley, B. C. H. ..	S.W. Reg. ..	31.12.45	Moore, A. E. ..	N. Ire. Reg. ..	31.12.45
Crompton, W. W. B.	N.E. Reg. ..	31.12.45	Bradman, A. R. ..	L.T.R. ..	31.12.45
<i>Exec. Engr.</i>			Cleary, H. ..	N.E. Reg. ..	31.12.45
Worthy, L. F. ..	L.T.R. ..	31.12.45	Maltby, A. G. ..	L.T.R. ..	31.12.45
Frost, J. ..	H.C. Reg. ..	31.12.45	Smith, H. G. ...	H.C. Reg. ..	31.1.46
Storey, W. J. ..	H.C. Reg. ..	31.1.46	<i>Insp.</i>		
Pope, G. F. ..	W. & B.C. Reg.	12.2.46	Rositer, G. W. ..	L.P.R. ..	31.8.45
Cresswell, W. H. ..	E.-in-C.O. ..	31.1.46	Pool, H. A. ..	H.C. Reg. ..	7.9.45
Cosh, L. G. ..	E.-in-C.O. ..	28.2.46	Mickley, T. ..	S.W. Reg. ..	5.10.45
<i>Asst. Engr.</i>			Lee, W. ..	N.W. Reg. ..	31.10.45
Furieux, E. G. ..	E.-in-C.O. ..	31.12.45	Lane, R. W. ...	W. & B.C. Reg.	28.11.45
Smith, G. ..	L.T.R. ..	31.12.45	Sumner, F. ..	L.T.R. ..	23.12.45
Lynn, B. ..	E.-in-C.O. ..	31.12.45	Lane, A. E. R. ..	Cable Test Section	31.12.45
Eaton, H. ..	N.W. Reg. ..	31.12.45	Darby, T. F. ..	L.T.R. ..	31.12.45
Nichols, E. H. ..	L.T.R. ..	31.12.45	Devereux, S. T. W. ..	L.T.R. ..	31.12.45
Colston, A. S. ..	N. Ire. Reg. ..	31.12.45	Maynard, G. W. J. ..	L.T.R. ..	31.12.45
Sinclair, R. ..	L.T.R. ..	31.12.45	Faithfull, A. J. ..	S.W. Reg. ..	31.12.45
Parton, J. E. ..	E.-in-C.O. ..	31.12.45	Coupland, C. E. ..	N.W. Reg. ..	31.12.45
Beazer, F. C. ..	L.T.R. ..	27.1.46	Payne, C. F. ..	N.W. Reg. ..	31.12.45
Hodge, H. R. ..	Mid. Reg. ..	3.2.46	Bedson, J. H. ..	N.W. Reg. ..	31.12.45
Kennard, E. G. ..	Test Section, London	9.2.46	Dodds, E. ..	N.E. Reg. ..	11.1.46
<i>Chief Insp. with Allee.</i>			Thorn, R. ..	S.W. Reg. ..	25.1.46
Jennings, J. ..	Scot. Reg. ..	30.11.45	Hughes, E. J. ..	L.T.R. ..	5.2.46
Knott, L. F. H. ..	H.C. Reg. ..	31.12.45	Endacott, J. ..	L.T.R. ..	9.2.46
Morphev, R. O. ..	L.T.R. ..	31.12.45	<i>Draughtsman, Class I.</i>		
Cockshott, W. E. ..	L.T.R. ..	17.2.46	Waddington, A. ..	E.-in-C.O. ..	30.11.45
Hill, C. H. ..	N.W. Reg. ..	28.2.46	Payne, R. P. ...	E.-in-C.O. ..	31.12.45

## Resignations

Name	Region	Date	Name	Region	Date
<i>Insp.</i>			<i>Insp.</i>		
Message, R. O. ..	N.E. Reg. ..	6.10.45	Andrews, G. L. ..	N.E. Reg. ..	3.1.46
Kelsey, T. G. ..	E.-in-C.O. ..	30.11.45	Bywater, L. E. ..	E.-in-C.O. ..	28.1.46
Barnes, H. ..	E.-in-C.O. ..	8.12.45	Boundy, J. R. ..	E.-in-C.O. ..	4.3.46
Cummins, P. A. ..	S.W. Reg. ..	31.12.45	Penfold, F. L. ..	L.T.R. ..	31.1.46



**Transfers**

Name	Region	Date	Name	Region	Date
<i>Exec. Engr.</i>			<i>Chief Insp.</i>		
Bevis, W. F.	.. N.E. Reg. to H.C. Reg.	9.12.45	Rowe, J. F.	.. E.-in-C.O. to S.W.Reg.	1.1.46
Jeffs H.	.. N.E. Reg. to H.C. Reg.	13.1.46	<i>Insp.</i>		
<i>Asst. Engr.</i>			Gerton, W. H.	.. L.T.R. to S.W. Reg.	15.10.45
Trussler, H.	.. Scot. Reg. to L.T.R.	10.2.46	Owens, J. J.	.. E.-in-C.O. to N.Ire. Reg.	1.1.46
Robertson, C. D. S. G.	E.-in-C.O. to L.T.R.	11.2.46	Barnett, W. J. G.	.. Scot. Reg. to E.-in-C.O.	7.1.46
Turtle, G. R.	.. Mid. Reg. to W. & B.C. Reg.	25.2.46	Tarbet, A. G.	.. E.-in-C.O. to Scot. Reg.	9.1.46
			Wyatt, E. J. R.	.. E.-in-C.O. to L.T.R.	1.2.46
			Teale, J.	.. E.-in-C.O. to N.E. Reg.	17.2.46
			Honeyman, J. B.	.. E.-in-C.O. to Scot. Reg.	7.3.46

**Deaths**

Name	Region	Date	Name	Region	Date
<i>Asst. Staff Engr.</i>			<i>Insp.</i>		
Barnes, E. J.	.. E.-in-C.O.	1.2.46	Lewis, F. G.	.. L.T.R.	31.1.46
<i>Chief Insp.</i>					
Bucklitsch, E. K. F.	.. S.W. Reg.	2.12.45			

**CLERICAL GRADES**

**Promotion**

Name	Region	Date	Name	Region	Date
<i>E.O. to S.O.</i>					
Walker, F. H.	.. E.-in-C.O.	7.1.46			

**Retirements**

Name	Region	Date	Name	Region	Date
<i>S.O.</i>			<i>E.O.</i>		
Bishop, H. G.	.. E.-in-C.O.	31.12.45	Winfield, A. L.	.. E.-in-C.O.	31.12.45
Harrison, F. A.	.. E.-in-C.O.	31.12.45	Howlett, T.	.. E.-in-C.O.	31.12.45
			Shanks, T. H.	.. E.-in-C.O. (Loaned to Home Office)	28.2.46

**Transfer**

Name	Region	Date	Name	Region	Date
<i>E.O.</i>					
Sellars, G.	.. E.-in-C.O. to N.E. Reg.	9.12.45			

**Deaths**

Name	Region	Date	Name	Region	Date
<i>E.O.</i>			<i>E.O.—continued</i>		
Devonshire, A. E.	.. E.-in-C.O. (Loaned to Ministry of Supply)	24.11.45	Fraser, W. M.	.. E.-in-C.O. (Loaned to War Office)	31.12.45

## Book Review

"The Decibel Notation and its Applications to Radio Engineering and Acoustics." 179 pp + 50 ill.  
By V. V. L. Rao, B.E., D.I.C., A.I.R.E. Addison & Co., Ltd., Madras, 1944. 8s. 6d.

Part I of this book describes the numerical basis of the db. notation, its origin and general use in telecommunications engineering. Part II deals with its special application to acoustics and the expression of the loudness of sound in terms of the phon. Part III is concerned with numerous practical applications of the db. technique to radio and acoustic engineering matters. Part IV consists of some appendices, which include tables of logs. and antilogs, as well as a bibliography and a useful index.

In regard to Part III, the numerical examples are set-out in detail and deal with a wide range of plant items, including audio amplifiers, radio receivers, gramophone record cutters and pick-ups, microphones, loud-speakers, transmitters, transmission lines and feeders, aerials, studio acoustic devices, attenuators and filters. The brief reference which, in many instances, is made to testing methods, adds considerable interest to these examples; the benefits accruing to students who devote time, thought and care to working through them, will, to a considerable extent, offset the shortcomings of the other sections of the book.

In the band-pass filter example, the calculations are very fully outlined. They are based upon the usual filter theory and enable the attenuation/frequency characteristic to be computed. There appears, however no special reason for the inclusion of this example, since the calculations throughout are in terms of nepers, conversion to db. being effected as a final operation

by the use of the usual multiplying factor. Nevertheless, since the calculations are followed by an outline of the method of measuring, in db., the insertion loss of a filter, this is possibly justification enough; in any case, the example typifies the industrious attention which the author has lavished upon the book.

Despite this expenditure of labour and painstaking care, it is a matter of regret that the book is vague in places owing to inexactness of wording and confusion of statement; many of the defects are due, perhaps, to imperfect English. So far as Parts I and II are concerned, the imperfections considerably obstruct the achievement of the author's objective. In fact, the author has the reader in difficulty from the outset; the first sentence of the book states that: "The most widely used unit in telecommunications engineering is the 'decibel'." A few sentences later one reads: "Strictly, it would be more rational to use the term 'decibel notation' rather than 'decibel unit'."

The text is amply illustrated by circuit diagrams and charts; some of the former are rather small and in some cases the figuring is difficult to read. There are a few misprints and there is an error in each of two column headings of Table 10.

In the foreword to this volume the author's treatment of this subject is described as "masterly." This is an exaggeration. The accurate presentation of a technical subject necessitates a command of the language employed for the purpose; the blemishes will constitute a severe drawback so far as elementary students are concerned.

A. M.

### BOARD OF EDITORS

A. J. GILL, B.Sc., M.I.E.E., F.I.R.E., Chairman.  
F. E. NANCARROW, O.B.E., A.R.C.Sc., M.I.E.E.  
P. B. FROST, B.Sc., M.I.E.E.  
A. H. MUMFORD, O.B.E., B.Sc.(ENG.), M.I.E.E.  
C. W. BROWN, A.M.I.E.E.  
G. H. S. COOPER.  
H. LEIGH, B.Sc.(ENG.), M.I.E.E., Managing Editor.  
G. E. STYLES, A.M.I.E.E., Assistant Editor.  
A. J. BAKER, Secretary-Treasurer.

### Copyright

The entire contents of this JOURNAL are covered by general copyright, and special permission is necessary for reprinting long extracts, but Editors are welcome to use not more than one-third of any article, provided credit is given at the beginning or end thus: "From the *Post Office Electrical Engineers' Journal*."

The Board of Editors is not responsible for the statements made or the opinions expressed in any of the articles in this JOURNAL, unless such statement is made specifically by the Board.

### Communications

All Communications should be addressed to the Managing Editor, *P.O.E.E. Journal*, Engineer-in-Chief's Office, Alder House, Aldersgate Street, London, E.C.1. Telephone: HEADquarters 1234. Remittances should be made payable to "*The P.O.E.E. Journal*" and should be crossed "& Co."

### Binding Cases

Cases for binding are available, and may be obtained from the Local Agents for 1s. 9d. Subscribers can have their copies of Volumes bound, at a cost of 3s., by sending the complete set of parts to the Local Agents or to the *P.O.E.E. Journal*, Engineer-in-Chief's Office, Alder House, Aldersgate Street, London, E.C.1. Orders for binding for Vols. 1-19 should indicate whether the original binding case with black lettering, or the later pattern with gold, is required. Cases with gold lettering are the only type stocked from Vol. 20 onwards.

### Back Numbers

The price of the JOURNAL, which is published quarterly, is 1s. (1s. 3d. post free) per copy, or 5s. per annum post free. Back numbers can be supplied, subject to availability of stocks, at 1s. each (1s. 3d. post free). Orders for back numbers may be sent to the Local Agents or to the Publishers.

### Advertisements

All communications relating to space reservations should be addressed to the Advertisement Editor, *P.O.E.E. Journal*, Alder House, Aldersgate Street, London, E.C.1. Communications regarding advertisement copy, proofs, etc., should be addressed to the Publishers, Messrs. Birch & Whittington (Prop. Dorling & Co. [Epsom], Ltd.), 49 Upper High Street, Epsom, Surrey.



The AvoMeter is one of a useful range of "Avo" electrical testing instruments which are maintaining the "Avo" reputation for an unexcelled standard of accuracy and dependability—in fact, a standard by which other instruments are judged.

**ONE INSTRUMENT** measures:—  
 Current, A.C. and D.C. (0 to 10 amps.)  
 Voltage, A.C. and D.C. (0 to 1,000 v.)  
 Resistance (up to 40 megohms)  
 Capacity (0 to 20 mfd.)  
 Audio-frequency Power Output (0 to 2 watts)  
 Decibels (—25 Db. to +16 Db.)

Write for fully descriptive pamphlet.

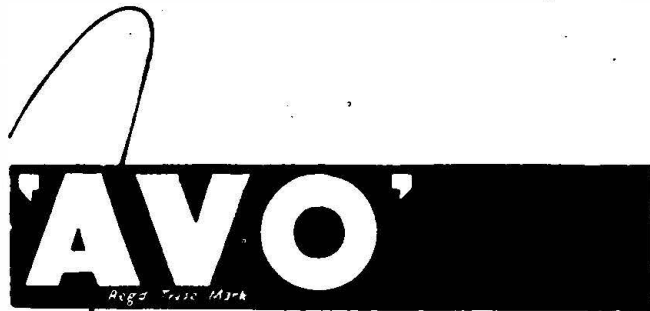

*Meters that Matter*

**THE Model 7 Universal AvoMeter** is the world's most widely used combination electrical measuring instrument. It provides 50 ranges of readings and is guaranteed accurate to B.S. first grade limits on D.C. and A.C. from 25 to 100 c/s. It is self-contained, compact and portable, simple to operate and almost impossible to damage electrically. It is protected by an automatic cut-out against damage through severe overload, and is provided with automatic compensation for variations in ambient temperature.

Sole Proprietors and Manufacturers

THE AUTOMATIC COIL WINDER & ELECTRICAL EQUIPMENT Co. Ltd.  
 Winder House, Douglas Street, London, S.W.1 Phone: Victoria 3404-B

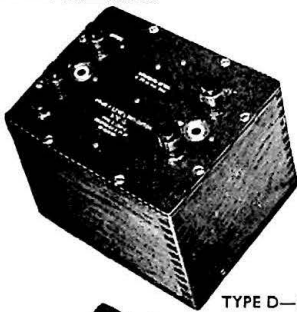

TYPE D-152-A

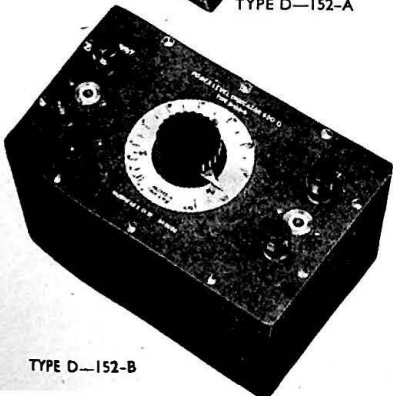

TYPE D-152-B

## POWER LEVEL INDICATORS

**POWER LEVEL INDICATORS**—TYPES D-152-A and D-152-B

Embodying a simple resistance bridge, self balancing at a predetermined power level—Robust—Accurate—Inexpensive.

Type D-152-A indicates a fixed power level; D-152-B is variable over a limited range.

Equally accurate on D.C. or A.C. Accuracy is independent of wave form and frequency up to 50 Kc/s.

With A.C., telephones will indicate balance to better than 0.1 db; a reasonably sensitive galvanometer (e.g. 100-0-100 $\mu$ A) gives equivalent discrimination with D.C.

Cannot be damaged by overloads up to 1,000 %.

Indispensable to Transmission Engineers, Meter Manufacturers, and others requiring a standard power level.

### STANDARD TYPES

TYPE NUMBER	POWER INDICATION Ref. 1 mW	INPUT RESISTANCE	DIMENSIONS	WEIGHT
D-152-A	+20 db $\pm$ 0.1 db	600 $\mu$ $\pm$ 1%	6" $\times$ 5" $\times$ 5 $\frac{1}{2}$ "	3 lbs.
D-152-B	+10 to +22 db $\pm$ 0.2 db	600 $\mu$ $\pm$ 5%	8" $\times$ 5" $\times$ 5 $\frac{1}{2}$ "	4 lbs.

Full particulars are given in Bulletin B-540-A a copy of which will gladly be sent on request.

**MUIRHEAD & CO. LTD., ELMERS END, BECKENHAM, KENT**  
 Beckenham 0041-0042  
 FOR OVER 60 YEARS DESIGNERS & MAKERS OF PRECISION INSTRUMENTS.

**MUIRHEAD**

*Clip-on*

# FOR EASY CURRENT MEASUREMENTS

in Busbars, Fuses and Cables up to 2½" diam.

- DUAL RANGE WITH SELECTOR SWITCH
- FULLY INSULATED CORE AND HANDLE

# FERRANTI

DUAL RANGE

## Clip-on AMMETER

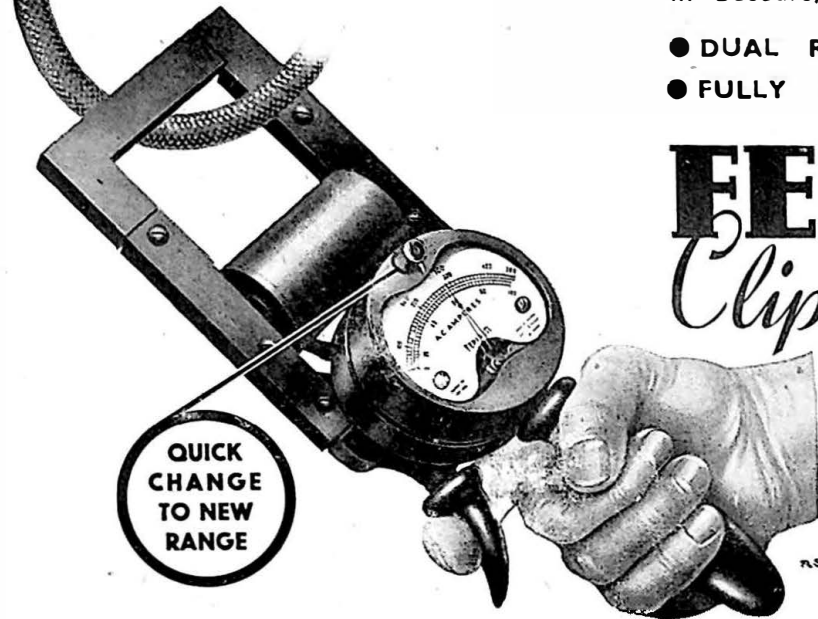

### RANGES

- 0—10—50 Amps.
- 0—20—100A mps.
- 0—50—250 Amps.
- 0—100—500 Amps.
- 0—200—1000 Amps.

F150a

FERRANTI LIMITED, Hollinwood, Lancs.

London Office: Kern House, Kingsway, W.C.2

## TURNER DIFFERENTIAL MILLIAMMETERS G.P.O. No. 17 & No. 18

Meet the most exacting demands for balancing currents in multiplex telegraph circuits.

— A quality product of outstanding merit —

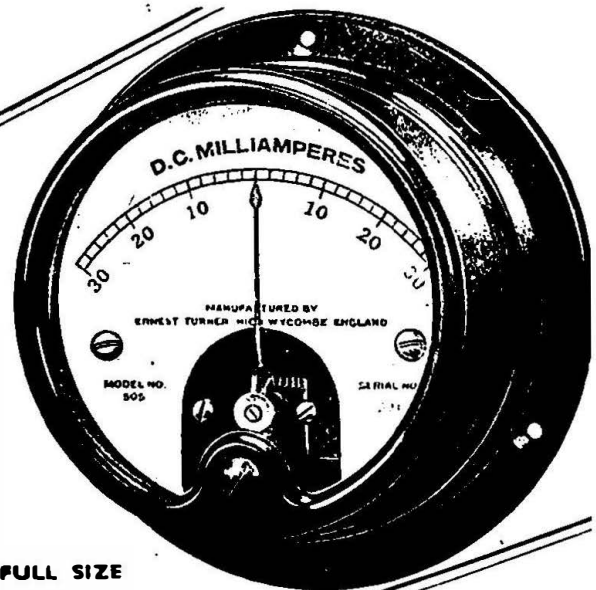

FULL SIZE

Also manufacturers of G.P.O. Detector No. 4, and a comprehensive line of instruments for precision electrical measurements.

### ERNEST TURNER ELECTRICAL INSTRUMENTS, Ltd.

CHILTERN WORKS,  
49-73 TOTTERIDGE AVENUE,  
HIGH WYCOMBE,

BUCKS. ENGLAND

Telephone: High Wycombe 1301, 1302.  
Telegrams: Gorgeous, High Wycombe.

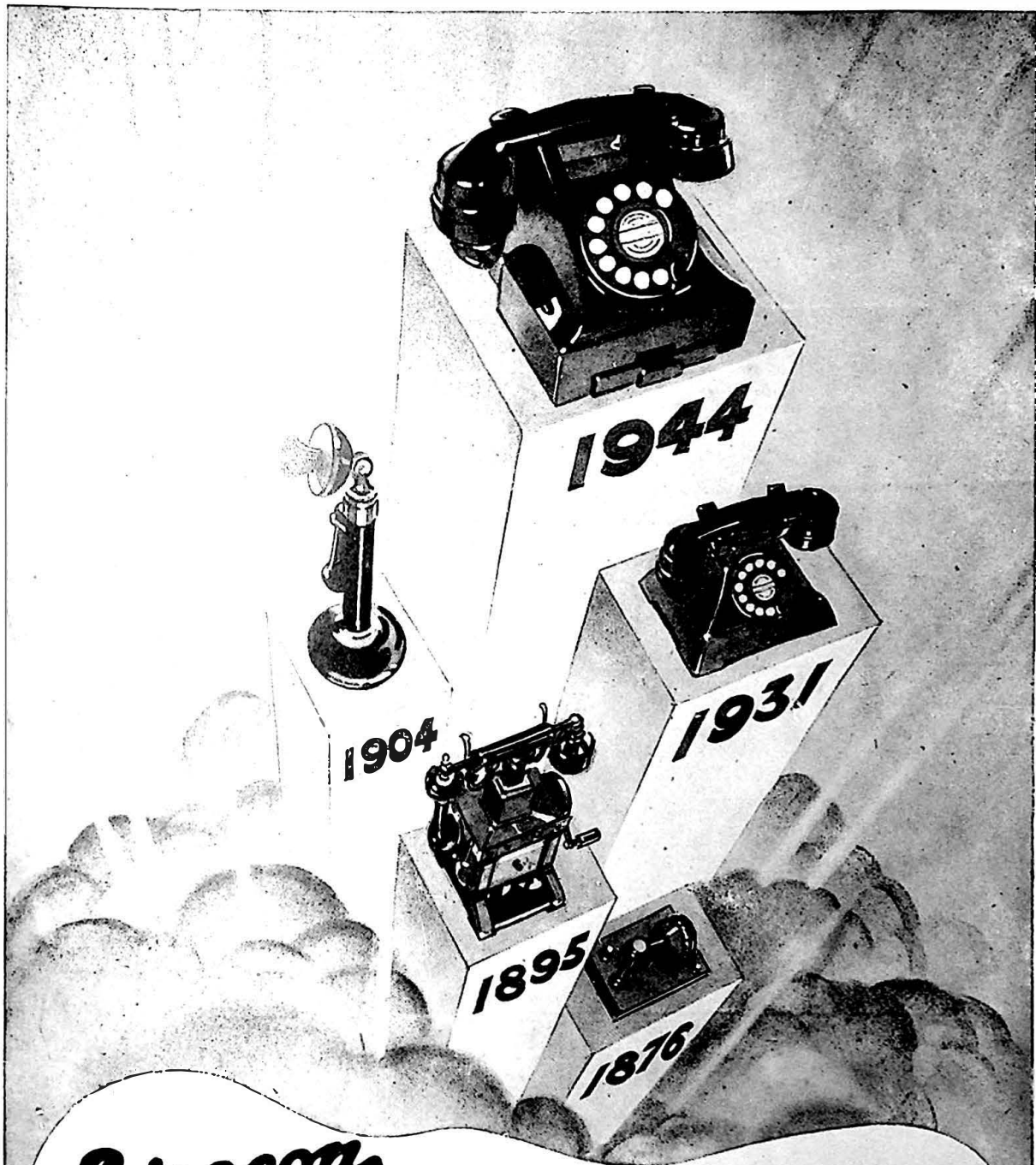

**Ericsson**

66 years of steady progress in telephony and its applications sees Ericssons in their extensive plant to-day utilising Modern Plastics for the improvement of telephone design and efficiency. Ericssons have unrivalled experience in

the production of telephone equipment required to function under tropical and similar extreme conditions—taking full advantage of the application of Plastics in this connection. Enquiries welcomed.

ERICSSON TELEPHONES LTD., Head Office: 56, Kingsway, London, W.C.2. Tel.:—HOL. 6936. Works Beeston, Notts.

# METAL RECTIFIERS

for use in Repeater Stations

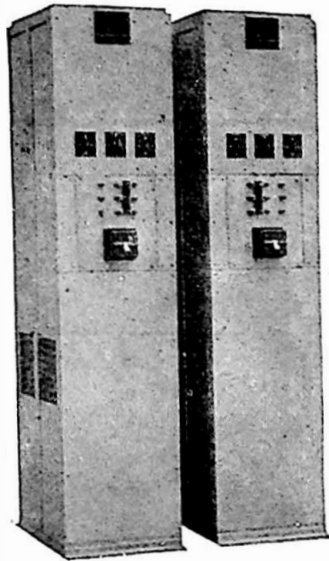

Rectifiers have been designed on the Moving-coil Voltage Regulator principle to "float" small H.T. and L.T. batteries in Repeater Stations, a large capacity "stand-by" battery being brought into service in the event of a mains failure.

Housed in the same cubicle as the "float" rectifier is a rectifier and transformer for recharging the stand-by battery, this circuit also acting as a stand-by to the "float" rectifier.

Also included is a trickle-charge rectifier to maintain the "stand-by" battery in good condition.

A typical equipment is illustrated, and consists of (a) rectifier and transformer for floating the L.T. battery, rectifier and transformer for recharging the "stand-by" L.T. battery and rectifier and transformer for trickle-charging the stand-by battery; and (b) identical equipment for use with the H. T. battery.



*the versatile rectifier  
of outstanding reliability*

**WESTINGHOUSE BRAKE & SIGNAL CO., LTD.**  
Pow Hill House, Chippenham, Wilts.

How much can you  
condense a condenser

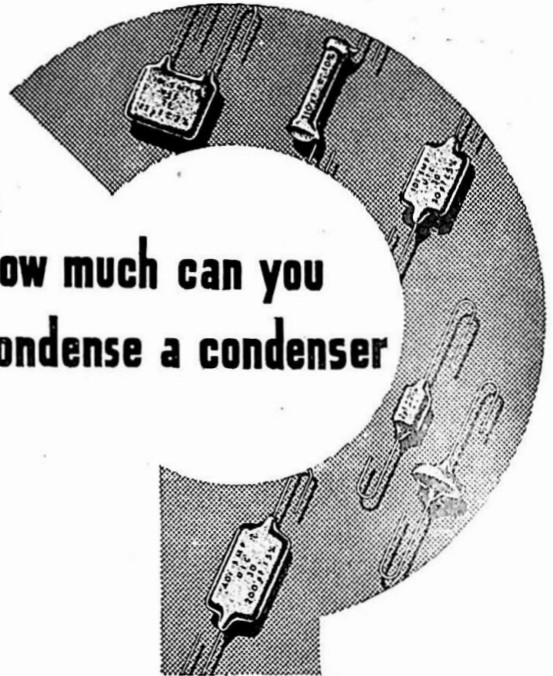

## *Midget Condensers*

Midgets in size but giants in performance are these U.I.C. Miniature Condensers. Especially suitable for use in the latest design of miniature radio transmitters and receivers, they are efficient and dependable under all climatic conditions. Made to specification K.110. Type approved. Full details on request.

**UNITED INSULATOR CO. LTD.**  
12-22 LAYSTALL ST., LONDON, E.C.1  
Tel: TEAmirus 7387 (5 lines) Grams: Colonel, Smith, London

THE PIONEERS OF LOW-LOSS CERAMICS

# SIEMENS

## TELECOMMUNICATION EQUIPMENT

AUTOMATIC TELEPHONE EXCHANGES  
including the following types

Trunk	T.A.X.
Main	M.A.X.
Rural	R.A.X.
Unit	U.A.X.
Private	P.A.X.
Private Branch	P.A.B.X.

MANUAL EXCHANGES  
of all types

CARRIER TRANSMISSION EQUIPMENT

TELEPHONE INSTRUMENTS  
of all types

TELEPHONE SWITCHING EQUIPMENT

PROTECTIVE DEVICES

RELAYS

TELEPHONE CABLES, WIRES & CORDS

LOADING COILS

MARINE RADIO EQUIPMENT

SHIPS' TELEGRAPHS & TELEPHONES

CELLS & BATTERIES

Dry, Fluid and Inert



*Designed for service  
in all parts of the world*

BY close attention to technical detail the Company has maintained its position in the forefront of Telecommunication Engineers throughout its long experience. Its products enjoy a world-wide reputation for sound design and technical excellence.

The Company undertakes the supply and installation of complete Automatic and Manual Telephone Exchanges for Public and Private service, Automatic and Manual Trunk Exchanges, all types of Telephone Cables for Trunk and Local Service, Carrier Transmission Equipment and Ship's Radio Equipment for Ships.

## SIEMENS BROTHERS

& CO., LIMITED

WOOLWICH

LONDON, S.E.18

# UNIVERSALLY ADOPTED

## G.N.T.Co. TRANSMITTER MODEL 112

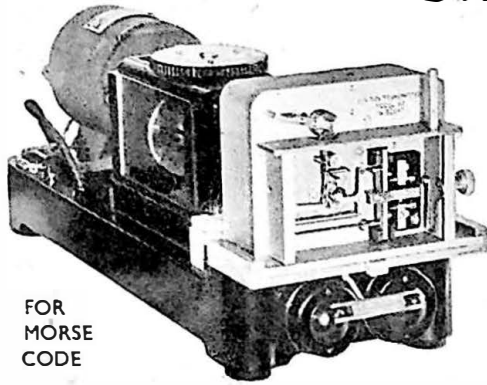

FOR  
MORSE  
CODE

13-250 words per minute without gear changes  
or readjustments.

Absolutely constant speed at all settings not-  
withstanding large voltage variations.

Noted for its easy maintenance.

Supplied with A.C. or D.C. motors as required.

**THE GREAT NORTHERN TELEGRAPH CO. LTD.**  
OF DENMARK

KONGENS NYTORV 28  
COPENHAGEN K. - DENMARK

AND

5, ST. HELEN'S PLACE,  
LONDON, E.C.3

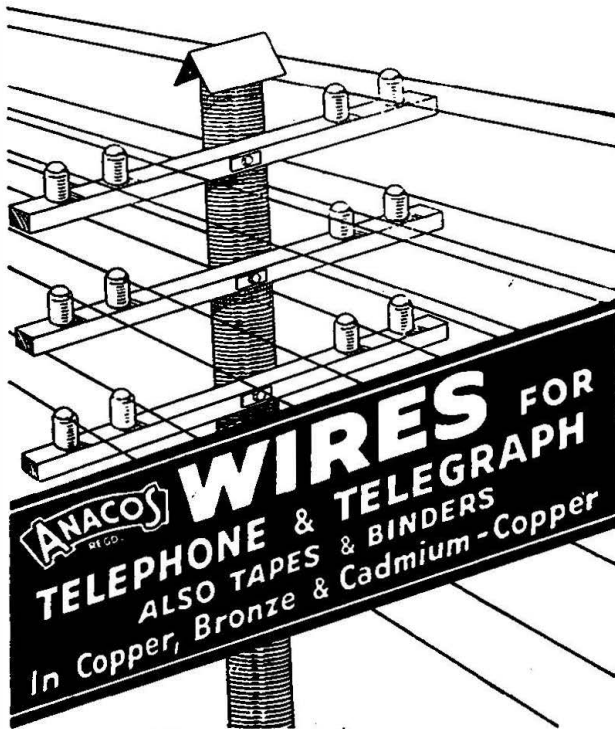

**FREDERICK SMITH & CO. LTD.** (Incorporated in The London Electric  
Wire Company and Smiths, Limited.)  
ANACONDA WORKS, SALFORD, 3. LANCs.  
Telephones: BLACKFRIARS 8701 (9 lines)  
Telegrams: "ANACONDA" MANCHESTER

## H. T. A. LIMITED

Formerly Hall Telephone Accessories (1928) Limited.

Contractors to H.M. Post Office, Admiralty,  
M.A.P., M.O.S., and Dominion and Foreign  
Administrations.

*Precision Engineers & Instrument Makers*

Manufacturers of Prepayment Telephone Multi-  
Coin Collectors, Gas Leak Indicators, Automatic  
Stamp Selling and Ticket Selling Machines,  
Automatic Slot Machines and Fire Alarm  
Apparatus.

*Enquiries Invited.*

Registered Office and Works:—

**DUDDEN HILL LANE, WILLESDEN,  
LONDON, N.W.10**

Tel. WILLESDEN 5141, etc. Also DOWLAIS, GLAM.



## LINK THE WORLD'S RESOURCES . . .



### IN THE RURAL AREAS

The two essentials upon which civilisation depends, firstly to exist and secondly to progress, are man's ability to toil and Nature's provision of material. This association is seen in its closest form in the rural areas . . . the plough lands, the corn belts and the plantations; for there are the soil and the fruits of the soil. It is their cultivation which meets the first need of mankind in food and subsequent requirements in the form of natural materials such as timber, rubber, cotton and the like. The inhabitants of such areas are comparatively few, widely distributed and occasionally isolated. Telephone service is very desirable and must cover internal connection between members of a perhaps tiny local community with facility for through-calling both to nearby townships and distant cities. It should also be available by day and at night. Strowger Unit Automatic Exchanges have been designed for just such circumstances; in result they enable operating authorities to provide service of a standard as high as that in any city at rates which are remunerative to themselves yet within the limited means of subscribers.

WITH

# STROWGER

## TELECOMMUNICATIONS

**AUTOMATIC TELEPHONE & ELECTRIC CO. LTD**

Export Department

NORFOLK HOUSE, NORFOLK STREET, LONDON, W.C.2 TEMple Bar 9262  
STROWGER WORKS • LIVERPOOL 7 • ENGLAND



A7051-Ba

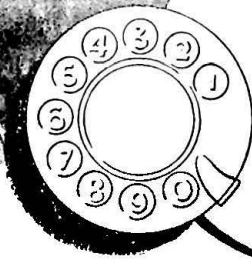

### UNIT AUTOMATIC EXCHANGE

- has been designed to serve small communities such as occur in rural areas.
- has the facility of functioning automatically and unattended.
- has a "24-hour"—that is day and night range of service.
- has unit construction; additional units can be added as the area develops.
- has means for the existence of faults to be checked by an operator at the parent exchange whilst serious fault alarms can be extended immediately.
- has switch-hook supervision for the manual operator at the parent exchange.
- has facility for calls to be made to subscribers on the parent exchange whether that be manual or automatic.
- has a dial speed range of 8 to 12 impulses per second and a voltage range of 46 to 52 volts.
- has automatic metering for local calls.
- has application to coin box working.
- has a special signal for the parent exchange operator when a call is made from a call office.
- has power supplied by accumulators with either a rectifier or dynamotor for charging.



# G.E.C.

*supply & install Everything for*

**ELECTRICAL COMMUNICATIONS**

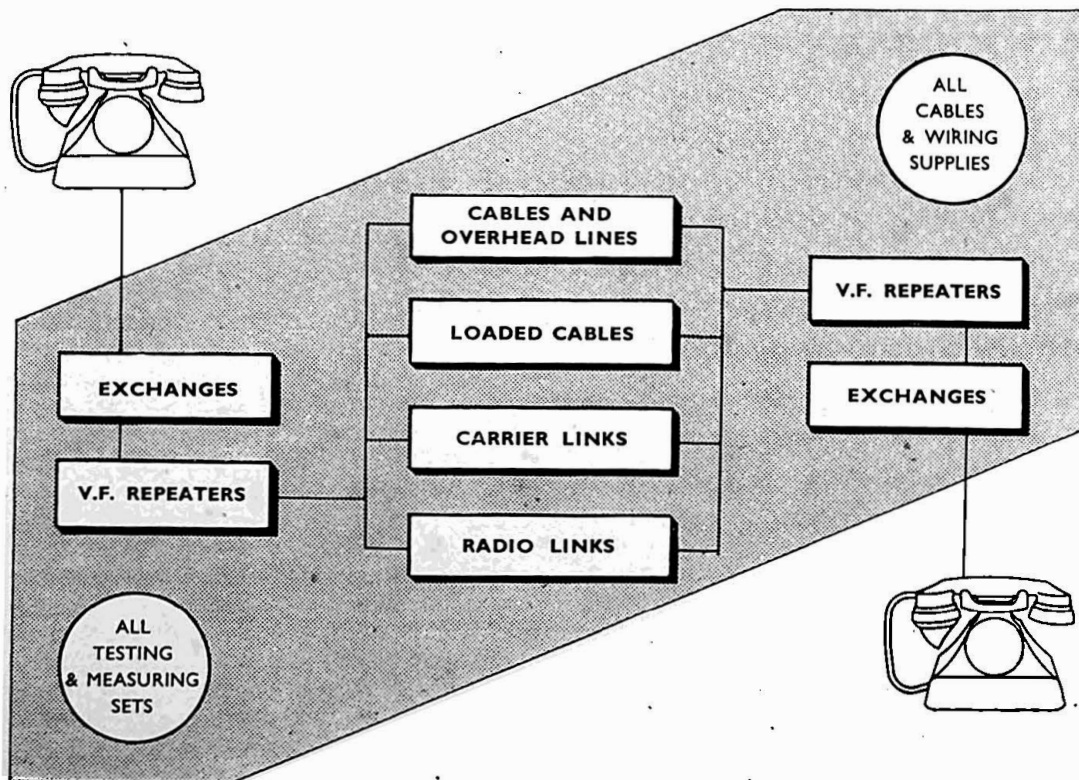

**THE GENERAL ELECTRIC CO. LTD. OF ENGLAND**

**Head Office: MAGNET HOUSE, KINGSWAY, LONDON, W.C.2, ENGLAND**

WAVEMETERS

OSCILLATORS

CONDENSERS

INDUCTANCES

RESISTANCES

BRIDGES — Capacitance  
Inductance  
Resistance

**H. W. SULLIVAN**  
— LIMITED —

London, S.E.15

Tel. : New Cross 3225 (P.B.X.)

ALL TYPES — ALL FREQUENCIES — ALL ACCURACIES

# ELLIOTT

MEASURING

*Instruments for Telecommunications Equipment*

**MOVING COIL,  
RECTIFIER AND  
THERMAL TYPES**

The instrument illustrated is a D.C. Differential Milliammeter. We also make . . . . . a four-range, rectifier-operated Milliammeter or Millivoltmeter for A.C. measurements at power and audio frequencies . . . . . and Telegraphic Transmitting, Receiving and Testing Equipment.



*Accurate & Reliable*

**ELLIOTT BROTHERS (LONDON) LTD. CENTURY WORKS, LEWISHAM, S.E.13**

# MAINTAINING EFFICIENCY

THE HIGH STANDARD OF EFFICIENCY  
OF PIRELLI - GENERAL TELEPHONE  
CABLES IS MAINTAINED BY THE  
CONTINUOUS RESEARCH WORK OF  
AN EXPERIENCED TECHNICAL STAFF.

TELEPHONE:  
SOUTHAMPTON  
2141 (5 lines).

**PIRELLI-GENERAL**  
CABLE WORKS, Ltd., SOUTHAMPTON.

TELEGRAMS  
"PIGEKAYBEL"  
SOUTHAMPTON "



*It's always there!*

Do not jeopardise production by taking the risk that the core of flux may be missing from the solder-wire you use. Be safe. Use Multicore 3-Core Solder. You will have, **always**, three cores of Ersin Flux—the fastest-action, non-corrosive, safety flux which makes "dry" or "H.R." joints impossible. Multicore is approved by A.I.D. and G.P.O. If you are engaged upon Government contracts write for technical information and samples.



## ERSIN MULTICORE

The Solder Wire with 3 Cores of Non-Corrosive Ersin Flux

**MULTICORE SOLDERS LTD., Mellier House, Albemarle Street, London, W.1.**

Telephone:  
REGent 1411 (P.B.X. 4 lines)