

THE POST OFFICE ELECTRICAL ENGINEERS' JOURNAL

VOL. 38

OCTOBER, 1945

PART 3

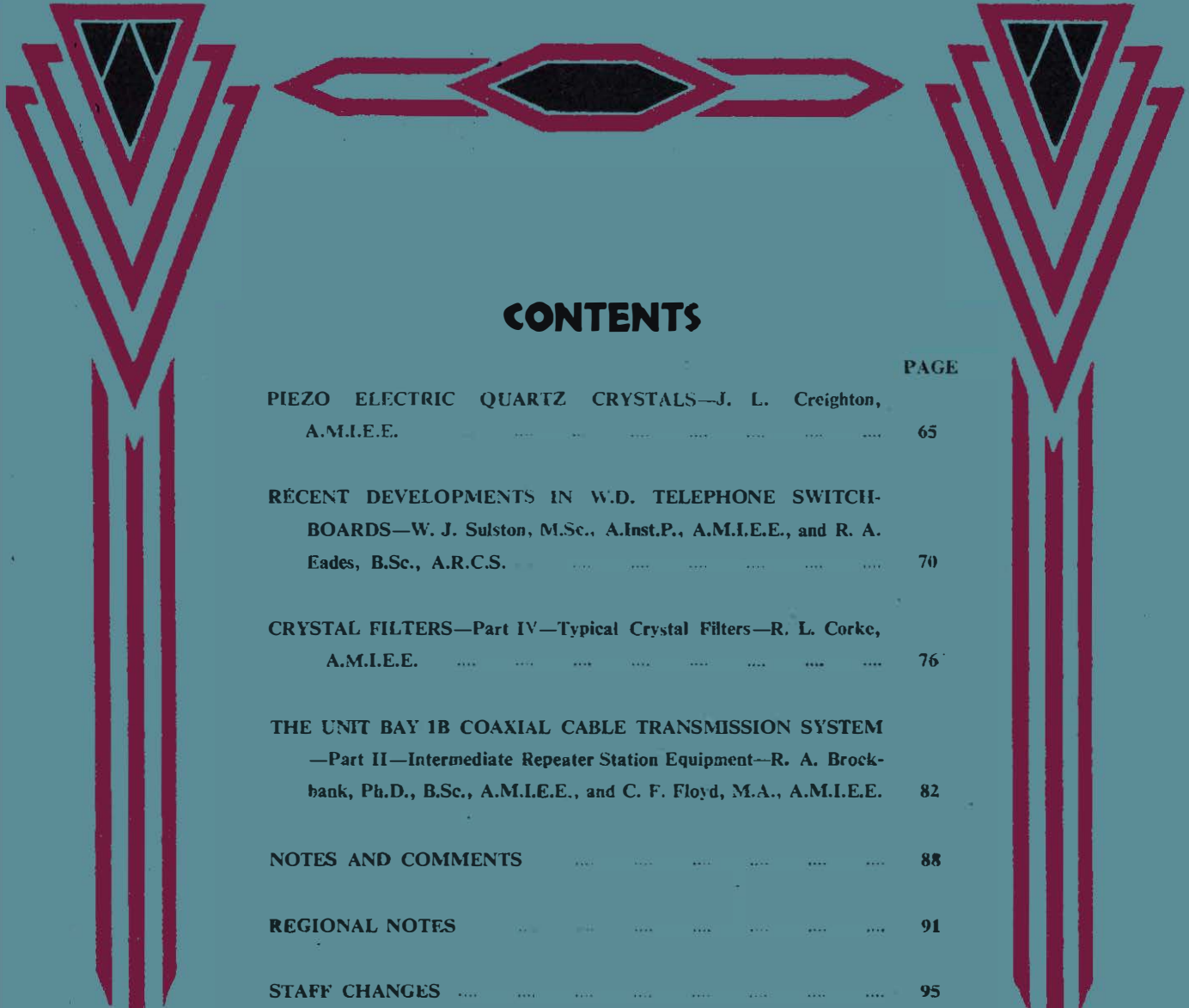

CONTENTS

| | PAGE |
|---|------|
| PIEZO ELECTRIC QUARTZ CRYSTALS—J. L. Creighton, A.M.I.E.E. | 65 |
| RECENT DEVELOPMENTS IN W.D. TELEPHONE SWITCHBOARDS—W. J. Sulston, M.Sc., A.Inst.P., A.M.I.E.E., and R. A. Eades, B.Sc., A.R.C.S. | 70 |
| CRYSTAL FILTERS—Part IV—Typical Crystal Filters—R. L. Corke, A.M.I.E.E. | 76 |
| THE UNIT BAY 1B COAXIAL CABLE TRANSMISSION SYSTEM—Part II—Intermediate Repeater Station Equipment—R. A. Brockbank, Ph.D., B.Sc., A.M.I.E.E., and C. F. Floyd, M.A., A.M.I.E.E. | 82 |
| NOTES AND COMMENTS | 88 |
| REGIONAL NOTES | 91 |
| STAFF CHANGES | 95 |
| JUNIOR SECTION NOTES | 96 |

Price 1/- net

THE INSTITUTION OF POST OFFICE ELECTRICAL ENGINEERS



GE CALLOY

RADIO CORES

Send for
New List
1944

SALFORD ELECTRICAL INSTRUMENTS LTD.

PEEL WORKS, SALFORD, 3. Telephones : BLAckfriars 6688 (6 lines). Telegrams and Cables : "Sparkless, Manchester"

PROPRIETORS: THE GENERAL ELECTRIC Co. Ltd., OF ENGLAND

EDISWAN

TELEPHONE LINE PROTECTOR PANELS

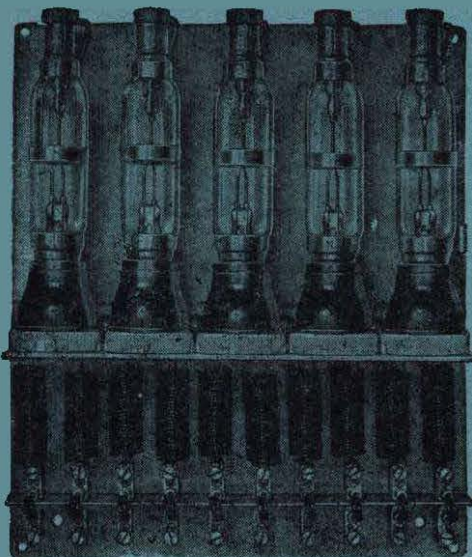

5-circuit panel for overhead lines incorporating choke coils, spark gaps, etc.

EDISWAN-SHOTTER-GREETHAM PATENT

(British Patent No. 353924)

for the protection of telephone systems against surges induced by faults on neighbouring power lines

Of the difficulties attendant upon the employment of overhead systems one of the most serious is to ensure uninterrupted working of the telephone system, by providing adequate protection against induced surges caused by switching or line faults in adjacent power lines or by lightning.

The Ediswan Patent Protectors provide the solution. They are inert at the normal working pressure of the telephone line, they keep the voltage on the line down to a pre-determined figure by providing a path of low resistance to earth whereby the surge is cleared and they again become inert immediately the surge is cleared.

They ensure simultaneous discharge of both lines and are capable of clearing heavy discharges without detriment to the system or the protector.

Ediswan Telephone Line Protectors have now been in use by Supply Companies for many years.

THE EDISON SWAN ELECTRIC CO. LTD.,  155 CHARING CROSS ROAD, LONDON, W.C.2

THE POST OFFICE ELECTRICAL ENGINEERS' JOURNAL

Vol. XXXVIII

October, 1945

Part 3

Piezo Electric Quartz Crystals

J. L. CREIGHTON, A.M.I.E.E.

U.D.C. 549.514.1 : 537.228.1

The author explains how the grouping of the constituent atoms in quartz gives rise to its piezo-electric effect and how the phenomenon is applied by the telecommunications engineer to produce resonant circuits of high Q value. Mention is made of the different modes of vibration and of how the variation of frequency with temperature is minimised.

Introduction

THE piezo-electric effect in quartz and in other crystals has been known since its discovery in 1881 by the Curie brothers, and has been applied in telecommunications as a means of frequency stabilisation since 1918. In more recent years the piezo-electric effect of quartz in particular has had greater and greater application and has been a major contributing factor in many of the great advances in the communications art.

physical properties. In quartz, silicon and oxygen atoms are so arranged with respect to each other as to lead to the chemical constitution SiO_2 . Although growth conditions may lead to the unequal development of faces or to the non-appearance of possible faces, within similar crystals of the same substance the atoms are always arranged in identical ways. Fig. 1 illustrates the appearance of idealised quartz crystals, i.e. similar faces are shown as equally developed, and Fig. 2 for comparison shows two natural crystals: The bases of the latter crystals have been cut for ease of mounting. The faces marked "m" in Fig. 2 are not the true m faces of Fig. 1, but slope as a result of growth conditions, leading to a gradual fattening of the crystals away from the pyramid ends.

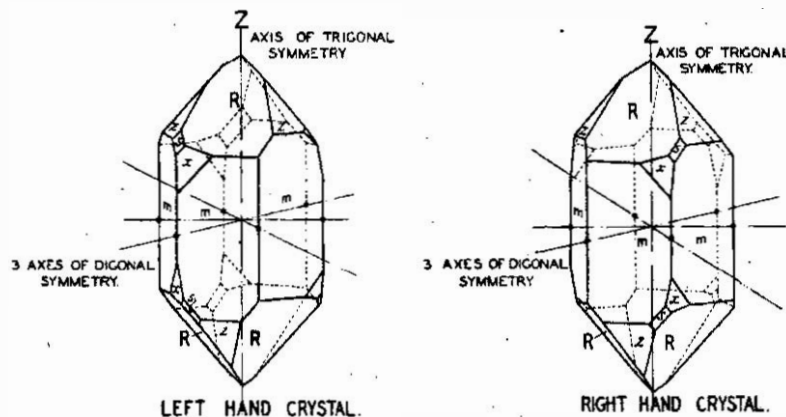

FIG. 1.—CLINOGRAPHIC VIEWS OF DOUBLY TERMINATED L.H. AND R.H. CRYSTALS.

A simple treatment of the piezo-electric phenomenon in quartz and of some of the applications is given in this article, which it is hoped will be of interest to those whose primary concern is the application of finished crystal units.

Crystalline Form

The piezo-electric effect (Greek *piezein*—to squeeze) is manifested by the appearance of electric charges at the exterior boundaries of crystals under certain conditions of stress, and the effects for any given material are the result of its particular crystalline structure. To call any substance crystalline is to imply a regularity of structure which usually manifests itself to the eye as a geometrical configuration of flat faces bounding the crystal. Inside the crystal the constituent atoms are arranged in a definite pattern which is repeated at distances of atomic dimensions, the symmetry of the pattern resulting in an external symmetry of shape and in internal symmetry of

Symmetry

For convenience in dealing descriptively with the crystalline properties of quartz the three axes which are shown as horizontal and parallel to prism faces in Fig. 1 are known as X axes, three Y axes at right angles to corresponding X axes are added, and the axis which passes through the apexes of the crystal is known as the Z axis. Thus each set of X and Y axes with the shared Z axis constitutes an orthogonal co-ordinate system. One such set is shown in relation to the crystal in Fig. 3. It is necessary to realise that the axes as described are not unique lines in the crystal but serve as identifying directions only. Thus any line parallel to the X axis direction may be used as the X axis.

It may be easily seen from Fig. 1 that if a crystal undergoes successive rotations of 120° about the vertical axis its appearance is unchanged. Also, if the crystal is rotated 180° about any of the three X axes the same result obtains. Thus quartz possesses threefold or trigonal symmetry about the Z axis, and twofold or digonal symmetry about each of the X axes. The Y axes are not axes of symmetry. This symmetry of external shape is of course obvious only when all similar faces are equally developed and is not always recognisable in natural crystals. However, the symmetry is always applicable to the

physical properties, e.g. the piezo-electric constants of quartz measured in a plane normal to the Z axis have equal maxima at intervals of 120° , so that the symmetry applies to any natural crystal. It will be noted that the faces at opposite ends of any line passing through the centre of the crystal are different,

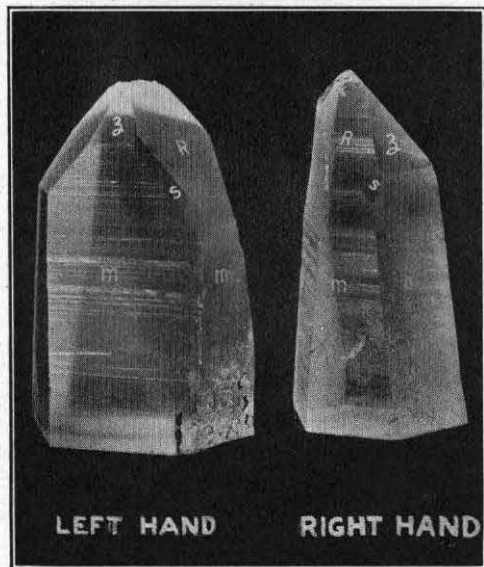

FIG. 2.—QUARTZ CRYSTALS (BASIS CUT SQUARE).

e.g. an R face at one end is opposite a z face at the other in this sense. The crystal has thus no centre of symmetry, since a centre of symmetry implies that no separation of electric charges is possible in any direction.

It will be seen that the crystals of Fig. 1 are mirror images and bear the same relation to each

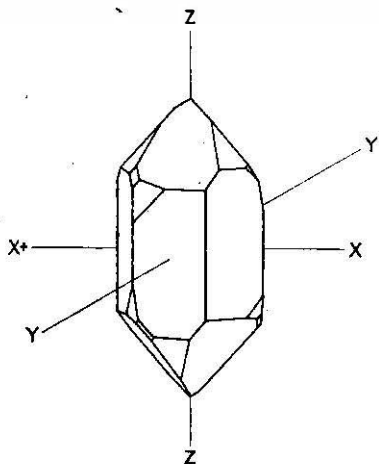

FIG. 3.—X, Y AND Z AXES

+ Indicates Sign of Charge for Compression along X Axis for L.H. Crystal.

other as do a pair of gloves. A crystal in which s and x faces occur under the right hand corner of an R face is known as "right" quartz, the mirror image being known as "left" quartz. The adjectives "right" and "left" also describe the behaviour of quartz to polarised light, right quartz rotating the plane of

polarisation of light in a clockwise direction to an observer facing the light source, and left quartz having the opposite effect.

Piezo-Electricity

For ease of describing the piezo-electricity of quartz it is convenient to adopt symbols for mechanical stresses and electric polarisations. Thus longitudinal stresses along the axes may be symbolised as X_x , Y_y , or Z_z stresses, and shear stresses as Y_x , Z_x , or X_y stresses. The generalised symbol A_i indicates a stress resulting from a force acting in the direction of the

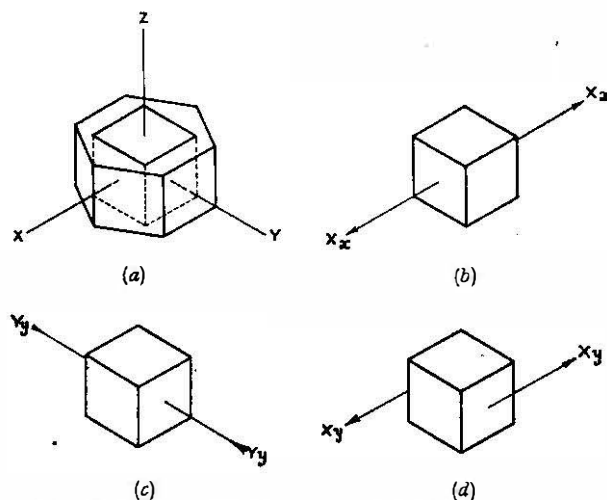

FIG. 4.— X_x AND Y_y DIRECT AND X_y SHEAR STRESSES.

A axis on a plane normal to the B axis. Fig. 4 will help to fix this convention in mind and shows a cube of quartz with faces cut normal to the X, Y, and Z axes. Fig. 4(a) shows the block in relation to the three axes and to a prism section of quartz, Fig. 4(b) the direction of an X_x tensile stress, Fig. 4(c) the direction of a Y_y compressional stress, and Fig. 4(d) the direction of an X_y shear stress. Electric polarisation, i.e. charge per unit area, may be represented by the symbols P_x along the X axis and P_y along the Y axis; in quartz there is no piezo-electric effect along the Z axis. The piezo-electric effect in quartz was first discovered in 1881 by the Curie brothers by the detection of electric charges at the ends of X axes (also known as electric axes) when X_x or Y_y stresses were applied to the crystal, the charges being equal and opposite in sign for the two conditions for similar stresses. Soon afterwards it was postulated and experimentally verified that the effect was reversible and that the application of electric stress resulted in mechanical strain. Later work showed that P_x polarisation was also produced by Y_y shear stresses and that P_y polarisation was produced by X_x and Z_z stresses, and that these effects were also, of course, reversible.

To obtain a physical explanation of the piezo-electric effect in quartz, it is convenient to consider a symbolic arrangement of the constituent silicon and oxygen atoms in a plane normal to the Z axis, i.e. containing the X and Y axes. Fig. 5 is such an arrangement due originally to Lord Kelvin, and illustrates also the orderly and symmetrical

arrangement of atoms typical of crystalline structure. Each small circle marked with a negative sign is to be regarded as a negatively charged double oxygen atom and each small circle marked with a positive sign as a positively charged silicon atom. The X axes of the quartz lie in the directions joining circles of opposite

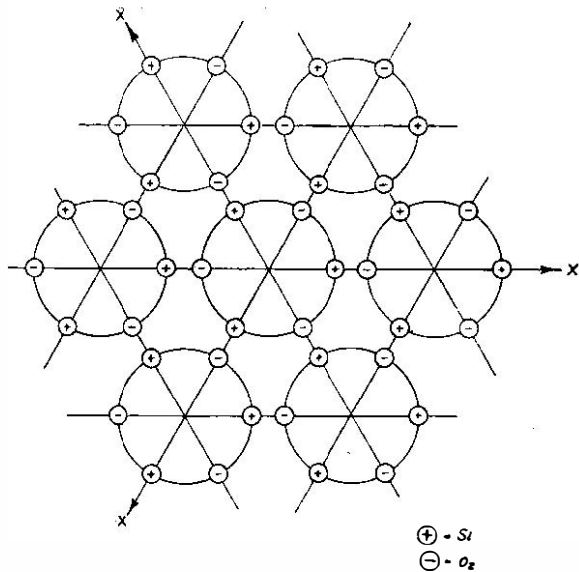

FIG. 5.—SYMBOLIC GROUPING OF ATOMS LOOKING ALONG Z AXIS (AFTER KELVIN).

polarity, and the diagram clearly shows the trigonal symmetry of the material about the Z axis which lies at right angles to the plane of the paper. A necessary assumption is made in using the configuration of such a diagram to explain the piezo-electric phenomenon, viz. that the atoms of each grouping, or crystal molecule, remain on the circumference of a circle and that positive and negative atoms remain at the opposite ends of a diameter when stressed.

Fig. 6 represents one of the self-contained groups or crystal molecules of Fig. 5. In Fig. 6 (a) the group

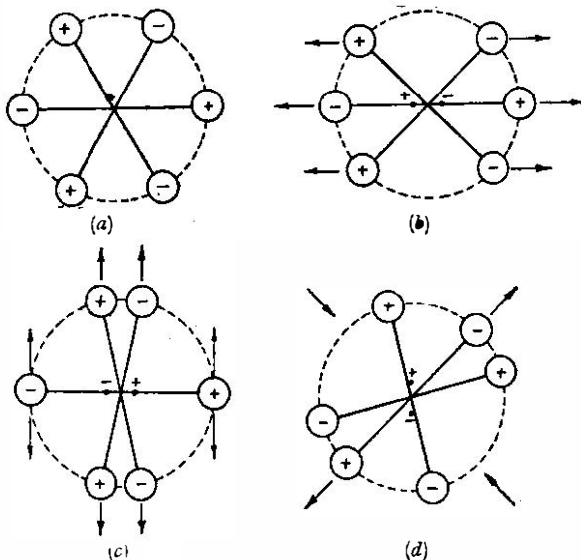

FIG. 6.—SEPARATION OF CHARGES UNDER STRESS

⊕ Resultant Charges.

is unstressed, the centres of gravity of the positive and negative atoms coincide, and no charge may be detected at the external boundaries of the crystal. In Fig. 6 (b) the crystal, and hence each unit within it, is to be considered as tensionally stressed along an X axis (+ X_x stress) when the atomic charges will be displaced from their original positions as shown in an exaggerated manner. The centres of gravity of the charges no longer coincide, but occupy positions such as to produce an electric moment. This separation of charges exists for all the atomic groups within the crystal and the net result is the appearance of charges at the external boundaries of the X axis. It is obvious that a compressive ($-X_x$) stress will produce opposite results. Fig. 6 (c) depicts the effect of a + Y_y stress, and again a separation of charges results but of opposite sign to that of the + X_x stress of Fig. 6 (b). Fig. 6 (d) illustrates the effect of an X_y shear. Such a pure shear is produced in practice as the result of two simple shears which inhibit rotation of the body as a whole and may be resolved along two directions at right angles. Thus the resultant of the shear is two longitudinal stresses, one compressional and one extensional, in directions 45° from an X axis, which distort the crystal molecule as shown so as to produce a separation of charges along a Y axis. Obviously an opposite effect is produced by a shear stress of opposite sign. These effects may be displayed by connecting a sensitive meter between electrodes in contact with surfaces cut normal to X or Y axes and applying appropriate stresses. On application of the stress a surge of current will be observed in a direction indicated by the foregoing treatment, and on releasing the stress a surge in the opposite direction will be seen. Although moderate stresses produce quite large voltages in certain other piezo-electric materials, the effect in quartz is not great. If the cube of quartz of Fig. 4 (b) be regarded as of one centimetre side and be stressed by 1 kg. in the X axis direction, a potential difference of approximately 55 V will appear across the X faces. Conversely, the application of a potential difference of 1 V will cause a change of length of approximately 2×10^{-10} cm.

Applications

An early application of the piezo-electric effect in quartz by the Curie brothers was to the determination of potential differences by measuring the distortion caused by their application across a special quartz unit. This unit was in the form of two thin bars the thickness being in the X direction and the length in the Y direction, the bars being cemented together with a strip of foil interposed and so poled that the outer faces had the same polarity to a similar stress. The outer faces were covered by foil electrodes connected together and the application of a potential difference between the inner and outer foils caused one element to expand and the other to contract along the Y axis. The net result was a bending of the bimorph element which could be measured by a system of levers, the amount of bending being proportional to the potential difference. It is recorded that by this means a potential difference of 50,000 V was measured to an accuracy of 200 V.

The application of the phenomenon to produce resonant elements follows quite simply from the static treatment. By virtue of its elasticity any arbitrarily cut element of quartz will have natural frequencies of vibration determined by its linear dimensions, density and the value of the elastic constant concerned in the particular mode of vibration. If an alternating electric field with a component in the X or Y direction is applied to the quartz element via a suitable electrode system the quartz will be driven with low amplitude into forced vibrations at the frequency of the applied field. If the frequency is varied so as to approach a natural resonance frequency of the quartz element the amplitude will increase and reach a maximum when the two frequencies coincide. Close to resonance the mass, stiffness and mechanical dissipation of the element may be converted into equivalent electrical

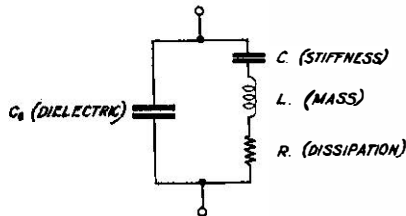

FIG. 7.—EQUIVALENT CIRCUIT OF QUARTZ ELEMENT.

elements, and Fig. 7 shows the equivalent circuit of a resonant element so derived. In addition to the mechanical equivalences there is a parallel capacitance C_0 which is the pure electrical capacitance of the quartz considered as a dielectric. In quartz the equivalent inductance is so high and the dissipation so small that the Q value is very high and depending on the mounting system usually lies between 10,000 and 500,000. The excellence of quartz as compared with tuned circuit elements is very marked even at the lower figure.

The equivalent circuit of Fig. 7 shows that there are two frequencies of resonance; the first, f_1 , occurs when, neglecting the effect of the very low resistance, the reactances of L and C are equal, and the second f_2 when the reactance of L and C combined equals the reactance of C_0 . At f_1 the resistance between terminals is $R \Omega$ and at f_2 it is equal very closely to $1/\omega^2 C_0^2 R$ i.e. to a very high impedance. The frequency difference between f_1 and f_2 varies according to the orientation of the crystal element, but in general is of the order of a fraction of 1 per cent. In using quartz elements as frequency controlling devices the commonest oscillator circuits are those in which the element operates at high impedance and Fig. 8

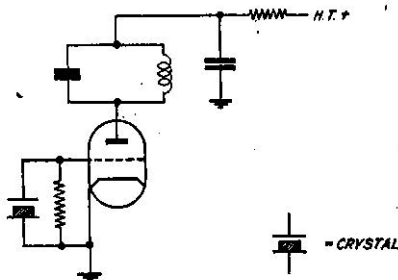
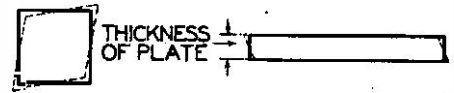
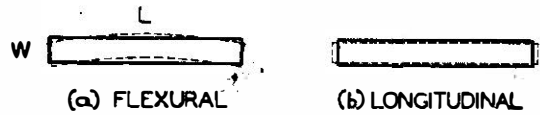

FIG. 8.—SIMPLE CRYSTAL OSCILLATOR DRIVE CIRCUIT.

shows a typical circuit of this type. Since the leads to the crystal and the grid-cathode capacitance add capacitance in parallel with C_0 , the frequency of oscillation will be lower than f_1 of the crystal alone. It may be shown that in such a circuit the crystal must oscillate at a frequency between f_1 and f_2 ; thus the range of frequency variation is restricted to a small value by the crystal constants alone and this, in conjunction with the high Q value, produces a frequency controlling device of high inherent stability.

In the design of quartz crystal units the particular type of crystal cut to be used is largely determined by the frequency of operation, since for practical reasons one cut, or mode of vibration, cannot be used over the whole range of some 4 kc/s to 20,000 kc/s over which quartz elements are practically realisable at the present time. The reason for this may be made clear by reference to Fig 9; Fig. 9 (a)



(c) FACE SHEAR (d) THICKNESS SHEAR

FIG. 9.—DEFORMATION ASSOCIATED WITH VIBRATION MODES.

shows the type of motion associated with a long bar vibrating flexurally, the frequency being proportional to W/L^2 . At 4 kc/s suitable dimensions of a quartz element of this type may be 6.25 cm. \times 0.3 cm. and at 100 kc/s some 1.4 cm. \times 0.4 cm. A reduction of frequency below 4 kc/s is difficult due to the smallness of the width and the largeness of the length dimensions. The first consideration renders electrode and holding arrangements very difficult and the second implies the use of very large raw quartz crystals and both result in an element difficult to handle in production. Above 100 kc/s the unit becomes very small in all dimensions and again difficult to mount and handle. However, by utilising a longitudinal mode of vibration with frequency inversely proportional to length, it is possible to cover a frequency range of 50 kc/s to 200 kc/s with practicable sizes of element. Fig. 9 (b) shows the type of motion associated with such a mode. From 100 kc/s to 1,000 kc/s a mode becomes practicable with frequency inversely proportional to length and width in which an approximately square plate distorts in the manner shown in Fig. 9 (c). This is known as a face shear or contour mode, and it is possible to drive this mode by reason of a piezo-electric shear effect similar to that illustrated in Fig. 5 (d). From 500 kc/s to 20,000 kc/s another type of shear mode, the thickness shear mode, with frequency inversely proportional to thickness, becomes practicable and the type of motion is shown in Fig. 9 (d). The modes of Fig. 9 (a)

and 9 (b) are driven by cutting elements in such a way as to allow the application of a component of the voltage in the X direction, whereas the modes of Fig. 9 (c) and 9 (d) utilise a component in the Y direction. The actual angles at which these elements are cut from the raw crystal are bound up with the demand for high stability of frequency when operating over a wide range of temperature. Change of frequency with temperature is partly due to the frequency/temperature coefficient of the elastic constant concerned with the particular mode of vibration adopted and this quantity varies with direction in the crystal. From both practical and theoretical considerations certain angular orientations have been worked out for all the modes of vibration mentioned, so as to give minimum frequency variation with temperature. The relationship is usually a close approximation to a parabola, so that the slope of the curve, i.e. the frequency/temperature coefficient, varies with temperature and is zero at one temperature in the working range. By a suitable choice of angle and also, in the case of certain of the modes, of dimensional ratios, it is possible to locate the temperature of zero coefficient at the mid-point of any normal temperature range and thus to obtain a minimum frequency variation over a very wide temperature range. It is possible by these means to produce without special effort quartz crystal units whose frequencies will remain within a tolerance of ± 0.02 per cent over a temperature range of -20°C to $+70^{\circ}\text{C}$. Much closer tolerances can be worked to at the expenditure of greater effort, and by utilising well designed drive circuits and temperature control of the crystal element it is possible to produce frequency standards the frequency stability of which is better than 1 part in 10^8 over a period of months and having a minute-to-minute stability of some 1 part in 10^{10} .

Suspension

To secure the best performance from any quartz oscillator the mounting arrangements require quite as careful consideration as the quartz element itself. Many different methods of suspension and of applying the driving voltage to the crystals have been adopted in the past. At the present time it appears possible to apply a universal technique to crystals covering the whole practicable frequency range by making use of a recent development. Briefly, this consists of applying to the quartz surface a silver paste containing also a compound such as lead borate. The crystal and paste spot are fired at around 550°C when the paste fuses and bonds strongly to the quartz. It then becomes possible to solder thin phosphor bronze leads to the silver spot and finally to coat the appropriate crystal surfaces with metallic electrodes by a cathode sputtering or an evaporation process. To reduce

mechanical damping to a minimum it is necessary to apply the spots either to vibration nodal regions or to inactive portions of the surfaces, when the lead wires may act both as electrical connectors and mechanical supports. The wires are proportioned to a length such as to minimise dissipation of energy from the vibrating system, and the free ends soldered to supports. Apart from the advantage of being almost universally applicable to all types of crystal element this method of suspension lends itself very readily to the assembling of the completed unit in a standard valve envelope assembly and by evacuating the envelope the damping due to the air is reduced and the effect of temperature variations minimised. Fig. 10 shows a crystal oscillator of 80 kc/s frequency

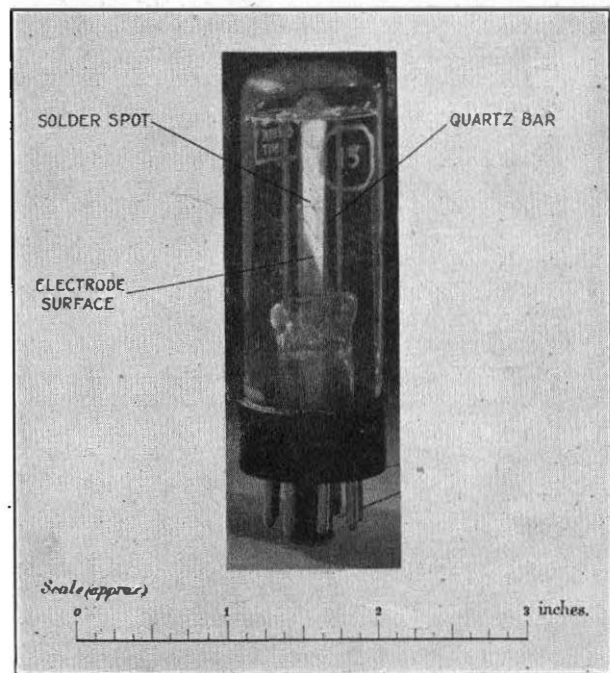

FIG. 10.—MOUNTED CRYSTAL OSCILLATOR—80 kc/s.

which utilises such a method of assembly and present development suggests that it may be possible to accommodate crystals covering the whole frequency range in this way.

Conclusion

In conclusion it must be emphasised that there are many more problems in the production of quartz crystal units than can be touched upon in this brief treatment and that as closer and closer tolerances are demanded each new requirement brings its own problems to be solved, there being no universal treatment of the whole field of quartz crystal usage.

Recent Developments in W.D. Telephone Switchboards

U.D.C. 621.395.33

W. J. SULSTON, M.Sc., A.Inst.P., A.M.I.E.E., and
R. A. EADES, B.Sc., A.R.C.S.
(Signals Research and Development Establishment).

This article gives a brief review of developments in W.D. telephone switchboards during the war and a more detailed description of the latest 10- and 50-line magneto boards.

Introduction

DURING the European and African campaigns from 1939 onwards the following switchboards were used:—

- (a) *Switchboards U.C. 10-line and 6-line* are portable switchboards designed for mobile operations. The 10-line switchboard is suitable for use in divisional signals and the 6-line switchboard for battalion and artillery requirements. The switchboards are constructed on the unit principle and comprise an operator's unit, 10- or 6-line units and a common apparatus unit. Connections are made by double plug-ended cords which are carried, together with pulley weights, operator's microphone and receiver, etc., in a separate box. The complete 10-line switchboard weighs $47\frac{1}{2}$ lb.

Each line unit includes a sensitive relay which operates via a bridge rectifier from either generator (17-25 c/s) or buzzer (300-700 c/s) signals. A current of about 1 mA is required to operate the relay, which lights a calling lamp supplied from a local battery.

Line fuses and lightning protectors are not included in the switchboard but are mounted in rigidly constructed frames known as "Frames D and P, 10-wire." Two frames are required for 10 lines and weigh 18 lb. 14 oz. complete with carrying case.

- (b) *Switchboards F and F* are designed for fixed exchanges and for field use. They are constructed on the unit principle to provide self-contained switchboards of 20- 40- or 60-line capacities. A maximum of three switchboards may be placed side by side to form a non-multiple exchange accommodating up to 180 lines. A teak case (Unit D) is used as a stand for the switchboard and a teak desk (Unit C) contains the operator's equipment, cords, keys and clearing indicators.

Five-line circuits are mounted on a framework (Units A and A/J). Units A are for magneto lines and Units A/J are for civil exchange lines. The exchange line circuits may be connected for any type of civil exchange by a plug and socket arrangement in the A/J Unit. Four Units A are mounted in a teak case with doors to form a Unit B, while three Units A and one Unit A/J are similarly mounted to form a Unit B/J.

A complete switchboard comprises a Unit C mounted on a Unit D. One Unit B/J and two Units B are mounted in that order on the Unit C, thus catering for five exchange lines and 55 extensions.

For transport Unit C packs into Unit D, forming a convenient load for two men, flush folding handles being provided for carrying. The doors of Units B and B/J close to provide protection during transport.

- (c) *Switchboard, Command, 200-line*, is designed for use at Army Headquarters and is constructed on the unit principle for transportation in enclosed units. Five switchboard positions are provided, and the exchange caters for 180 extension lines and 20 exchange lines. The answering and multiple equipment is contained in a single unit ("A"), 9 ft. 6 in. long which extends over the whole length of the switchboard when installed. Each operator's keyboard and cord equipment is contained in a "Unit B." Unit C is a trestle on which the exchange is mounted. All units are constructed of waxed teak woodwork of substantial design, and Unit A, which weighs 750 lb., has a robust steel framework.

The face equipment of Unit A comprises hand-restored drop indicators which are mounted above the multiple jacks. There are three appearances of the complete multiple over the nine panels of the Unit. A Line Test Panel is also provided. The exchange line circuits work to any type of exchange.

In addition to the above Army switchboards, extensive use has been made for fixed installations of a number of Post Office boards, including Switchboards AT3796, P.M.B.X. No. 1A and standard sleeve control switchboards.

The above switchboards cover a large field of Army requirements. The extension of the war to the Far East led to the need for a 10-line switchboard which could be carried by one man through the jungle for fairly long periods. The weight of the Switchboard 10-line U.C. ($47\frac{1}{2}$ lb.) is too great, and this switchboard is not suitable for use in tropical theatres owing to the severe climatic conditions. A maximum weight of 25 lb. is reasonable, and to achieve this the new switchboard is designed to work with a field telephone as the operator's instrument. To avoid the use of a separate mounting to carry line fuses and protectors the switchboard itself is fitted with protectors. Buzzer calling is dispensed with and the switchboard is designed for generator signalling only. The equipment developed is known as Switchboard, Magneto, 10 Line (W.D.); further details are given in this article.

A further requirement arose for a magneto multiple exchange to replace the Post Office N.T.7 equipment which was obsolescent. The equipment was required for home and overseas military installations of a

static nature. The General Electric Company, Ltd., had developed a switchboard which, with certain circuit changes, met Army requirements. The equipment is known as Exchange, Magneto (W.D.) Unit Type "N" Positions and is described below.

Another exchange equipment developed by the Automatic Telephone and Electric Co. and the Signals Research and Development Establishment, in collaboration with the Post Office, is known as "Exchanges, C.B. Multiple, Unit Type, N Positions," and this will form the subject of a separate article.

SWITCHBOARD, MAGNETO, 10-LINE (W.D.).

General

The switchboard is designed to work in the open in any part of the world. In tropical forest areas, such as Malaya, Burma and the East Indies, the rainfall is constantly heavy on most days in the wet season and the day air temperature may rise to 40° C. Relative humidities from 80 to 100 per cent. are common. Under such conditions of high humidity and relatively high temperature, fungus growth may be prolific. The main effects on electrical equipment are to promote the collection of moisture and produce a deterioration in the properties of insulating materials.

In desert regions as encountered in North Africa the air temperature may rise to 60° C. during the day and fall to freezing point at night. Perhaps the most severe hazard in such areas, however, is the dust and sand storms; the continual abrasion produced by swiftly moving particles may result in severe damage to equipment. Low extremes of temperature are reached in exposed arctic regions in Siberia, Alaska and North-Eastern Europe, where temperatures of -55° C. are relatively common.

The wide range of conditions which equipment must withstand imposes severe limitations in the choice of materials. The main components of the Switchboard, Magneto, 10-line have been designed specially for the job, and all materials have been carefully chosen and specially finished.

The general arrangement of the switchboard is shown in Figs. 1 and 2. A web-carrying strap, which

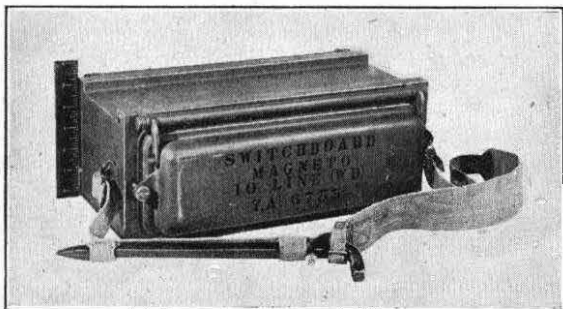

FIG. 1.—SWITCHBOARD, MAGNETO, 10-LINE (CLOSED FOR TRANSPORT).

is specially rot and fungus proofed is provided, and a small earth pin is attached to it during transport. The weight (including earth pin) is 23 lb., and the dimensions 14 $\frac{1}{2}$ in. \times 9 $\frac{1}{2}$ in. \times 5 $\frac{1}{2}$ in.

The outer case, which is shown closed for transport

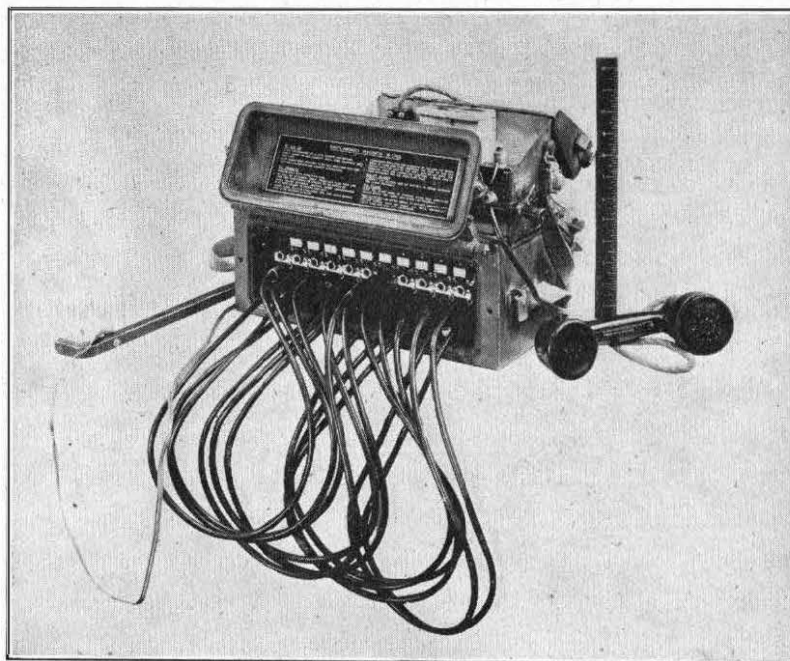

FIG. 2.—SWITCHBOARD, MAGNETO, 10-LINE (TELEPHONE SET READY FOR USE).

in Fig. 1, is constructed from No. 20 S.W.G. mild steel and is welded. All fixtures are welded to the case, so that apart from the main openings for the front and rear panels of the switchboard, it is sealed. The slot in the top of the case is a sliding fit for a field telephone (Telephone Set J or L), which is shown mounted ready for operation in Fig. 2. The front and rear openings are covered with lids, also made of No. 20 S.W.G. mild steel and provided with rubber gaskets $\frac{3}{8}$ in. square cross section, which fit tightly into channels in the lids. Each lid is secured to the case by a loose hinge and is closed by two brass captive screws which engage with tapped brass bushes secured to the inside of the case. When the lid is closed the gasket forms a sealed joint with a raised portion of the case. A plate of high grade synthetic resin paper laminated sheet engraved with brief working instructions is held in the front lid and a similar plate engraved with the circuit diagram in the rear lid. The front lid provides storage space for the cords when the switchboard is closed and the rear lid carries a small buzzer which is used as an alarm. The copper earth braid which is shown connected to the earth pin in Fig. 2 is wound round cleats on the rear of the case for transport and is covered by the rear lid when this is closed.

The circuit diagram of the equipment is given in Fig. 3. Each line circuit comprises a two-point jack, an indicator and a cord which is terminated in a plug. Protectors are connected between each line and the earth terminal of the switchboard.

The indicator is connected permanently across the line so as to eliminate faults due to dirty contacts on the jack and to facilitate the design of the jack. The insertion loss due to a standard indicator across a 600 ohm circuit is 0.15 db. at 300 c/s, 0.1 db. at 500 c/s and less at higher frequencies. Since the line attenuation is lowest at low frequencies the effect of two drop indicators across a connection is negligible. The alarm contacts of the indicators are connected to two "Alarm" terminals on the

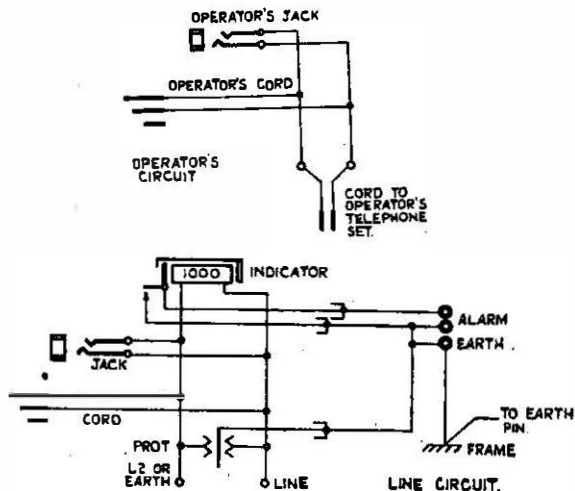

FIG. 3.—CIRCUITS OF SWITCHBOARD, MAGNETO, 10-LINE.

back panel and provide night alarm facilities when the buzzer, which is carried in the rear lid, is connected in series with one or two dry cells across the alarm terminals. Spare batteries carried with the field telephone are used for this purpose. The earth braid is permanently attached and is electrically connected with the case; a short end connects to the earth terminal of the switchboard and a 5 ft. length terminates in a tag for connection to the earth pin. The operator's circuit consists of a

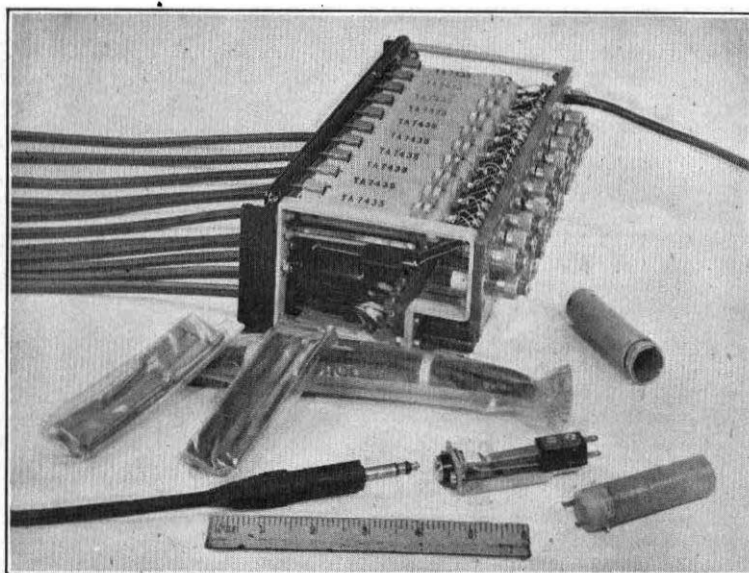

FIG. 4.—SWITCHBOARD, MAGNETO, 10-LINE. CHASSIS AND COMPONENTS.

jack, single plug ended cord which is provided with a removable red rubber sleeve to distinguish it from the line cords and a telephone cord which is used to connect the switchboard to the telephone set.

Chassis Assembly

The layout of equipment is seen in Fig. 2 and the chassis assembly is shown in the background of Fig. 4. The 18 S.W.G. mild steel front mounting plate carries the main components. The ten line cords and one operator's cord pass through rubber grommets at the bottom of the panel and the plugs are normally placed in "parking" sockets which are moulded in phenol-formaldehyde. Above the parking sockets are the jacks and indicators which are so designed that insertion of a plug into a jack restores the associated indicator by an auxiliary spring on the jack. The operator's circuit is on the left of the panel and no indicator is required in this position. Calls are normally answered by inserting the operator's plug into the jack of the calling line, but an operator's jack is provided for emergency use if the operator's cord fails. Unit construction has been sacrificed to achieve compactness, but the components of each line circuit are in one column. During transport the indicator shutters would tend to move about, and to prevent this a locking bar, which is spring loaded, is provided; it is readily moved from the locking to the working positions. The method of operation is standardised and is simple, but it should be observed that "conference" facilities are available, since any number of circuits may be connected together.

The terminal panel at the rear is $\frac{1}{4}$ in. thick synthetic resin paper laminate of the best electrical quality. A high resin content is essential to ensure that the material does not support fungus growth. The ten pairs of line terminals and the earth terminal are slotted so that Army line wires may be connected direct to them. A large size is used to facilitate operation with gloved hands in cold areas. The alarm terminals also are mounted on the terminal panel and the telephone connector passes through it. The holes seen above the line terminals are to facilitate adjustment of the indicators which are provided with a screw at the back to alter the sensitivity. This screw may be adjusted without opening the switchboard by passing a suitable screwdriver through the holes in the terminal panel.

The twenty pairs of protector carbons are mounted below the terminal panel. Nickel-silver springs which are held under the terminals make contact with the upper protector of each pair. A plate made of nickel-plated brass provides the common earth connection. Screw terminals, to which the line and telephone cords are connected by spade terminals, hold and make contact with an intermediate point of the springs. The systematic connection of lines is essential when using earth return circuits, and the top row of terminals is labelled "LINE" and the bottom row

"L2 or EARTH." To ensure correct connections inside the switchboard, both during initial assembly and during maintenance, 4 BA screw terminals are used for the ring connections, and 6 BA for the tip. Corresponding spade terminals on the line connectors are provided. The tops of the nickel silver spring contacts take the form of soldering tags and connections to the indicator coils and jacks are made from these points, using 14/0076 stranded wire with slack between the spring and the indicator. The use of stranded wire with some slack in it is necessary to eliminate damage due to bumping and vibration, which all Army equipment is liable to encounter during transport.

Components

The main components used are shown in Fig. 4. Conditioning at 60° C, 95-100 per cent. relative humidity revealed the following sources of insulation breakdown in standard telephone type jacks:—

- (a) The use of laminated insulating wafers in the spring pile-up,
- (b) Surface leakage from spring to spring on the outside of the spring pile-up,
- (c) The existence of a short leakage path from spring to spring along the holes used for the fixing screws.

The connection of the indicator permanently across the line enables a two-point jack with no inner springs to be used and increases the distance between adjacent springs. The tip and ring springs are moulded in a block of high grade phenol formaldehyde and all metal parts have a high resistance to corrosion. A third spring which is coupled to the "ring" spring is so positioned that it automatically restores the indicator shutter when a plug is inserted in the jack.

The line connectors are carried in the front lid of the switchboard and must, therefore, be as small as possible. Braided cords are ruled out owing to the difficulty in making them mould and rot-proof and to the danger of erosion when they are used in a sandy or dusty environment. Rubber-covered cords are therefore used. Tests made on standard plugs indicated that low insulation resistance was caused mainly by leakage inside the plug. The outer cover is dispensed with and the body of the plug is moulded in rubber, which is bonded to the rubber sheath of the cord. The conductors are tinsel and each is rubber-covered.

The telephone connector is also rubber-covered, but 55/42 S.W.G. copper wire conductors are used. There is of course relatively little movement of this connector. The ends which connect to the field telephone are stripped and soldered to facilitate easy connection.

The indicator used is developed from the Army type MR3, which is of robust construction. The coil is constructed by winding on a polythene moulded bobbin and then moulding a layer of polythene over the winding to form a seal with the cheeks of the bobbin. After exposure to 10 damp heat cycles to Specification W.T. Board No. K110 the insulation resistance of six samples ranged from 11 megohms to 18,400 megohms.

The use of this type of protection, however, reduces the space available for winding, and the minimum number of turns for the tropical type (Indicator MR4) is 9,450 as compared with 12,150 for the normal type. The sensitivity is somewhat less, the A.C. (16½ c/s) operate voltage being 15 V instead of 12 V.

Two spare line connectors and 20 protector carbons are carried in a spares compartment in the case. Each line connector and each group of 10 protectors are provided with a polyvinyl chloride (P.V.C.) bag (Fig. 4)—which is heat sealed round the edges. The spares are thus protected from damp and fungus until they are actually required.

Luminising

To facilitate operation of the switchboard in the dark, luminous paint is provided on the indicator label holder underneath the label, which is moulded in a transparent material, such as methyl methacrylate, with the back concave to leave space for the paint and the front matt to allow it to be written on. The labels below the jacks are also treated with luminous paint. To make the luminosity independent of an external source of light, which would be required every 8 to 10 hours with phosphorescent paint, a radioactive paint which contains radium is employed. The radiation from the radium causes fluorescence of a suitable material in the paint, which is therefore luminous in the dark until one of the materials is used up. An effective life of two to four years is anticipated.

Performance

Comprehensive climatic and other tests indicate that the complete switchboard will stand up well to the most severe conditions it will encounter. The grade of the components is such that the chassis, out of the case, may be rinsed in water to clean out dirt and sand. It functions normally as soon as surface water has been removed.

EXCHANGES, MAGNETO (W.D.), UNIT TYPE "N" POSITIONS.

General Description

This exchange is designed for permanent installations of 50 to 300 extensions and 10 to 60 exchange lines. Each position ("Switchboard, position, magneto 10 + 50/60 No. 1") accommodates 10 exchange line circuits—which may work to magneto C.B.S. 1, 2 and 3, C.B. and automatic exchanges—and 50 extension circuits working to magneto telephones. The weight and dimensions are given in Table 1:—

TABLE 1

| Equipment | Weight lb. | Height in. | Breadth in. | Depth in. |
|-------------------------|------------|------------|-------------|-----------|
| Switchboard position .. | 420 | 48 | 26½ | 31½ |
| Multiple Unit | 180 | 18 | 53½ | 17 |

An exchange may consist of one, two, four or six positions. A multiple unit ("Units, switchboard, magneto, multiple, 360 line, No. 1") is fitted over each pair of positions in four and six position exchanges. One and two position exchanges do not require a multiple unit. Fig. 5 shows two positions

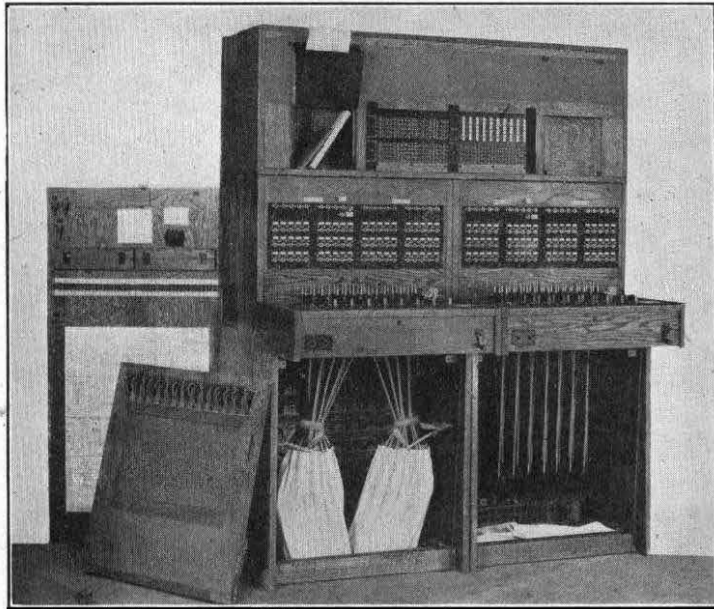

FIG. 5.—SWITCHBOARD POSITION, MAGNETO 10 + 50/60, AND SWITCHBOARD UNIT, MAGNETO MULTIPLE, 360 LINE.

and a multiple unit which is fitted for illustration only.

Standard Post Office "Frames, M.D. 0/240", are used for the M.D.F. and the I.D.F. Table 2 shows the constitution of exchanges of various sizes.

TABLE 2

| Extension lines | Exchange lines | Positions | Mult. Units | Frames 0/240 | | Rectifiers No. 38B | Battery Capacity |
|-----------------|----------------|-----------|-------------|--------------|--------|--------------------|------------------|
| | | | | M.D.F. | I.D.F. | | |
| 50 | 10 | 1 | 0 | 1 | 0 | 1 | 85 Ah |
| 100 | 20 | 2 | 0 | 2 | 0 | 1 | 85 Ah |
| 200 | 40 | 4 | 2 | 3 | 2 | 2 | 340 Ah |
| 300 | 60 | 6 | 3 | 4 | 3 | 2 | 340 Ah |

Constructional Details

The positions and multiple units are constructed of teak and the components have the normal tropical finish provided by the manufacturers for equipment which is to be used in protected places. The whole of the signalling equipment is mounted in the positions and no apparatus rack is required. The answering jacks are combined with Indicators MR3, which are jack restored, as already explained.

The key shelf is lower than is normal in multiple switchboards in order that ordinary chairs may be used by the operators. The cords, however, are of such length that each may reach the furthest jack in the multiple. This is made possible by the use of double-pulley cord weights. Each key shelf is equipped with 15 cord circuits, which include supervisory lamps, "dial and ring answer" keys and "speak and ring call" keys. A night alarm key, a position coupling key and a dial are also provided per position.

The multiple unit contains standard type jacks wired to connection strips and is constructed to fit over two positions as seen in Fig. 5. A strip of linoleum is fixed above the jack field for pinning notices, and a pigeon-hole is provided on each side.

Each position is provided with spare lamps and fuses and a set of labels marked 50-99 (the answering indicators being labelled 0-49 as despatched) for use on the even-numbered positions. Space is left for the hundreds digit if required. These spares are carried on the rear panel of the position.

Two operator's jacks, connected in parallel, are provided on each position. One is Post Office "Jack No. 20" and may be used with P.O. head and breast sets, the other is the standard Army operator's jack (equivalent to P.O. Jack No. 8).

During transport the cord weights are held in strong canvas bags which are anchored to the floor of the position.

Installation

The switchboard is designed for operation from a 24 V power supply obtained by rectification of the mains, using a "Rectifier No. 38B" with floating secondary batteries. It is possible, in the event of the mains failing, to use the operator's circuit with 3 V dry cells by altering a strap in the rear of the switchboard. Supervisory signals are not given during emergency working.

Ring current is normally provided by a ringing vibrator which works from the exchange battery and has an output comparable with that of a hand generator. A hand generator (similar to P.O. "Generator No. 26A") is fitted in each position as a standby.

"Cable, switchboard, enamelled" is used for cabling from the M.D.F. and I.D.F. to the multiples and to the positions. P.V.C. insulated wire is used for jumpering on the M.D.F. and I.D.F.

Facilities and Circuits

The main circuits are shown in Fig. 6. The extension calls the switchboard by turning the generator handle, and the corresponding drop indicator operates. While a plug is in the jack relay SA is operated to the 400 ohm earth in the extension circuit so that when the handset is replaced on the extension telephone the release of relay A lights the supervisory lamp.

The exchange line circuit enables the switchboard to be connected to automatic, C.B., C.B.S. 2 or 3, and magneto exchanges or, by a change in the strapping, on a tag-strip at the back of the position, to C.B.S.1 exchanges. A slow releasing relay S operated by the auxiliary springs of its exchange jacks practically eliminates the possibility of false calling signals being given when clearing a connection. No supervision is provided on exchange line circuits.

Two groups of conference jacks are fitted above the answering jacks and indicators. For the purpose of setting up lengthy conferences without using up

the normal cord circuits, 30 double-ended cords are stored behind the kicking panel in such a manner that they are accessible to the operator. Conferences may be set up by means of these cords connected from the conference jacks to either the answering jacks or the multiple jacks. One normal cord circuit

in many respects than the conditions met in civil practice. The wide range of climatic conditions met and rough handling during transport necessitate the best possible finish to all parts and a sturdy construction. Poor lines, which are frequently unavoidable under battle conditions, unskilled labour

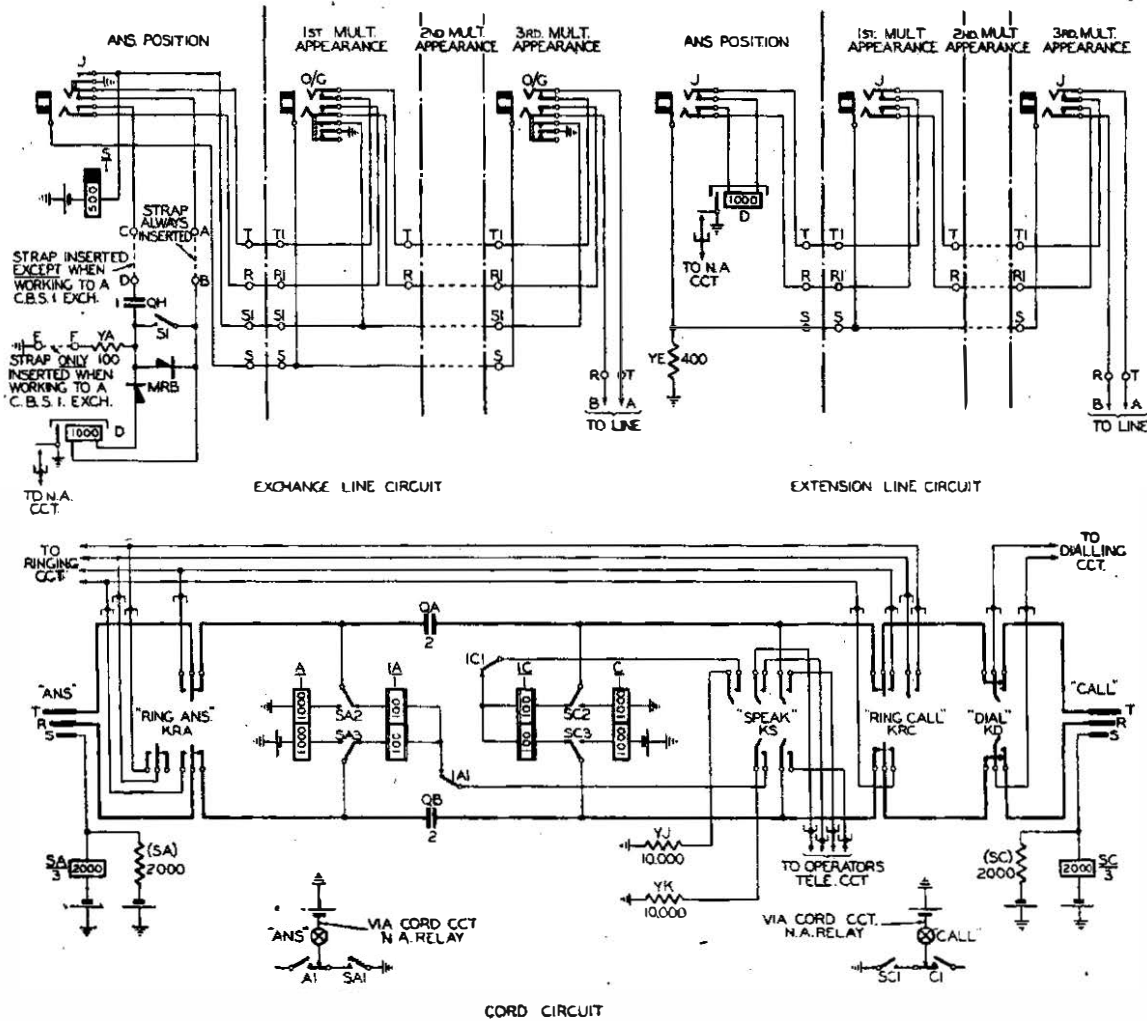

FIG. 6.—MAIN CIRCUITS OF W.D. MAGNETO MULTIPLE EXCHANGE.

at least must be used for each conference for supervisory purposes. Two conferences may be set up simultaneously on each position.

When the Night Alarm key is operated an audible signal is given whenever an indicator operates or a supervisory lamp glows. The same audible signal is given if a fuse blows (irrespective of the Night Alarm key), but a visual signal is also given. Temporary operation of the Alm. Dis. key stops the bell but leaves the fuse alarm lamp glowing until the fuse is replaced.

Conclusion

In conclusion it is stressed that W.D. conditions of use of communications equipment are more varied

for installation and varied accommodation impose further limitations in design. When portability is necessary requirements become conflicting and an agreed compromise may be the only solution.

Acknowledgments are due to the Telephone Manufacturing Co., Ltd., who first put the Switchboard, Magneto, 10-line (W.D.) into production and effected improvements in the design, and to the General Electric Co., Ltd., who developed the Switchboard, Position, Magneto 10 + 50/60 No. 1 and the Unit Switchboard, Magneto, Multiple, 360 line No. 1 and provided the photograph in Fig. 5. The authors wish also to thank the Chief Scientific Officer, Ministry of Supply, for permission to publish this article.

Crystal Filters

R. L. CORKE, A.M.I.E.E.

Part IV.— Typical Crystal Filters

U.D.C. 621.318.7 621.392.52

This final article of the series describes a selection of crystal filters representing current practice.

A Simple Crystal Filter

IN Part III a simple lattice section consisting of two resonators and capacitors is shown to yield a narrow pass-band with one frequency of peak loss which can be in either attenuation band. In a design summarised in the appendix to Part 3 the element values and the resonator dimensions are worked out for a filter with its pass-band centred on 60 kc/s and with a frequency interval of 118 c/s between the design cut-off frequencies. The single peak of loss is located at 61.8 kc/s. A filter to this basic design has been constructed, but the circuit actually used, Fig. 1, differs somewhat from the

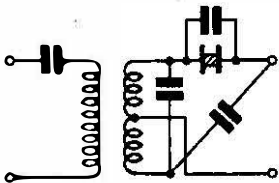

FIG. 1.—CIRCUIT OF SIMPLE BAND-PASS CRYSTAL FILTER.

symmetrical lattice form of the theoretical design, though the two are substantially electrically equivalent to each other.¹ A tuned differential transformer is used in conjunction with one series arm and one lattice arm of the original design. This modification has marked advantages over the lattice form, for only one resonator is required and the input and output circuits can be made unbalanced to earth

¹ W. P. Mason, "Electromechanical Transducers and Wave Filters," 1942, p. 262.

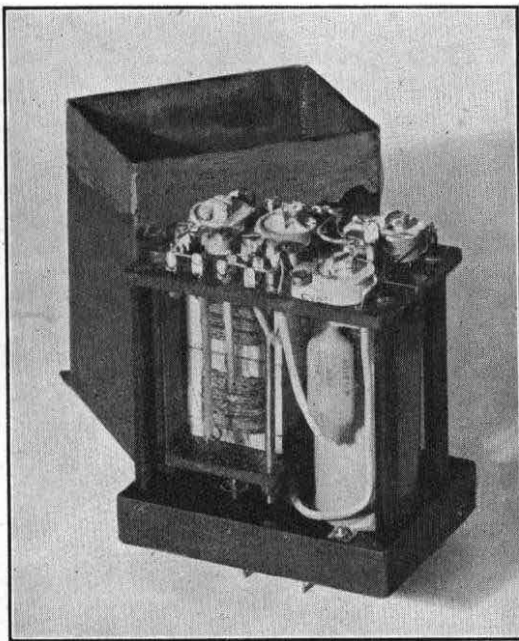

FIG. 2.—CONSTRUCTIONAL DETAILS OF SIMPLE BAND-PASS CRYSTAL FILTER.

if desired. The transformer is designed as a band-pass filter with a mid-band frequency of 60 kc/s, but its bandwidth, some 10 kc/s, is very much greater than that of the crystal filter section.

The appearance of this filter is shown in Fig. 2. The components can be seen mounted inside the lid of the filter case with the tubular resonator holder fitted underneath a platform and adjacent to the dust cores and bobbins of the tuned transformer. The platform also serves as a mounting for four preset capacitors. Two of these are used for the transformer and the other two are associated with the crystal filter section. These capacitors enable the filter to be accurately adjusted to make allowance for stray capacitances and small manufacturing tolerances in the filter components so that the filter can be made to have the correct bandwidth and the frequency of peak loss can be made to occur at the design frequency. The curve in Fig. 3 shows the theoretical insertion loss of the crystal section alone compared

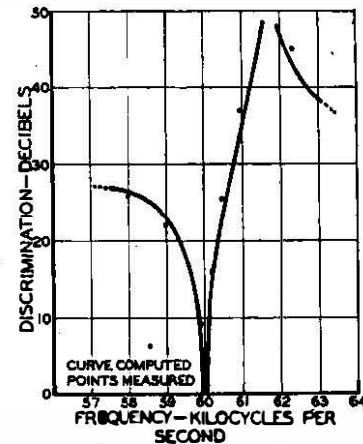

FIG. 3.—THEORETICAL AND MEASURED DISCRIMINATION OF SIMPLE BAND-PASS CRYSTAL FILTER.

with the measured discrimination, that is, the insertion loss plotted in relation to the loss at 60 kc/s; the curve has been computed using a method described elsewhere.² "Insertion loss" means the additional loss placed in a circuit when the filter is inserted. The term is fully defined in the first of the articles to which reference has just been made.

A Lattice Filter with Four Resonators

The simple type of filter just described is somewhat limited in its usefulness since, as has been explained in Part III, the bandwidth cannot in practice exceed about 0.3 per cent. of the mid-band frequency because of the restriction by the resonator and the presence of stray capacitances. It is frequently

² P.O.E.E.J. Vol. 35, pp. 88 and 111.

desirable to use a filter with an insertion loss characteristic which has a somewhat wider pass-band. Such a filter can be made by using a resonator in each of the four arms of the lattice network with the circuit shown in Fig. 4 (a). The reactance characteristics of the series and lattice arms, Fig. 4 (b),

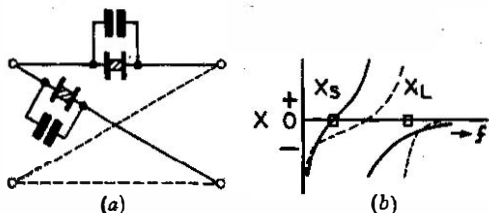

FIG. 4.—LATTICE SECTION EMPLOYING FOUR RESONATORS.

are arranged so that the anti-resonance of the series arm has the same frequency as the resonance of the lattice arm. This results in a band-pass filter with two intervals in the pass-band and therefore two frequencies of peak loss. The maximum width of the pass-band for a filter of this type is about twice as great as that for the first example chosen since both frequency intervals in the pass-band can have a percentage bandwidth of up to 0.4 of the mid-band frequency with, therefore, a total maximum percentage bandwidth of about 0.8 for the complete pass-band. As with the previous filter, it is desirable to make some allowance in the design for the effects of stray capacitance appearing across the resonators, and the widest bandwidth for which the filter may be designed is about 0.6 per cent. Applications of this type of filter are for the selection of single frequencies, e.g. to select a carrier system pilot frequency or to isolate a particular harmonic frequency from a series in the output of a harmonic generator.

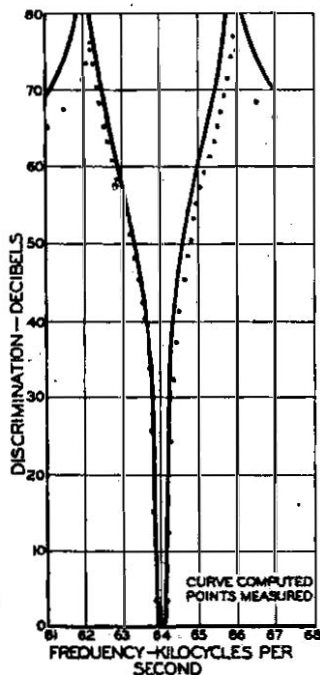

FIG. 5.—MEASURED AND COMPUTED DISCRIMINATION OF LATTICE FILTER EMPLOYING FOUR CRYSTAL RESONATORS.

In these applications it is usually desirable that the insertion loss characteristic should be approximately symmetrical for frequencies below and above the frequency to be selected; this is done by placing the peaks of loss symmetrically on each side of the pass-band. A typical insertion loss curve of this form is shown in Fig. 5 for a filter with a mid-band frequency of 64 kc/s; the curve has been computed and the points measured. As with the simple type of crystal filter, the four-crystal lattice network can be realised in an economical manner, using an equivalent network consisting of a differen-

tial transformer and one each of the series and lattice arms, i.e. only two resonators. In the practical design the capacitance required across each resonator is provided in part by small preset capacitors which can be set during the adjustment of the filter.

A variation of this type is to arrange for the two parts of the pass-band to be separated by making the anti-resonance of the series arm occur at a frequency a little lower than the resonance of the lattice arm, Fig. 6 (a). Thus two pass-bands are to be found separated by a frequency interval in which loss can develop. With a small interval between the pass-

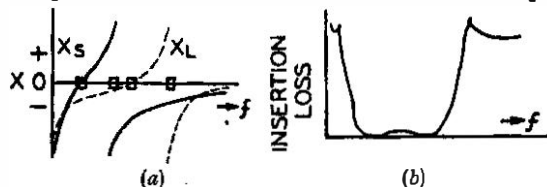

FIG. 6.—ALTERNATIVE ARRANGEMENT OF SECTION SHOWN IN FIG. 4 (a)—SOMEWHAT WIDER PASS-BAND.

bands the rise of insertion loss between the two pass-bands is small and the net result is a characteristic with effectively one single pass-band, Fig. 6 (b), with two frequencies of minimum insertion loss and between them a frequency of slightly greater loss. Since the two pass-band intervals still exist, though separated, there are two peaks of infinite loss which can be located, for example, one on each side of the main pass-band. For moderate separations the useful pass-band tends to have a more uniform loss over a wider range of frequency than can be obtained from the type where the two pass-bands are confluent. The disadvantage of this double pass-band design is that, for given frequencies of peak loss, the loss at frequencies well away from the pass-band tends to be less than that provided by the form with one theoretical pass-band.

A Simple Bridged-T Crystal Filter—Bartlett's Bisection Theorem

A filter section which includes only one resonator bridged across an equal winding transformer, Fig. 7 (a), forms a simple high impedance band-pass filter which is useful as an I.F. filter for use in a radio receiver. For the purpose of explanation and design this network can be turned into the symmetrical lattice form by the application of Bartlett's Bisection Theorem,³ the use of which will now be explained. By replacing the resonator in Fig. 7 (a) with its equivalent circuit and by replacing the transformer (which has self-inductance L for each winding and mutual inductance M between the windings) by its equivalent T network, the circuit of Fig. 7 (b) is obtained. A line is now drawn through the network, which is bisected along this line, so that the two parts are identical. The dividing line passes through the points 1, 2, 3 and 4, Fig. 7 (c), which points will here be referred to as "terminals of symmetry." Bartlett's Theorem states that having bisected a network and severed the connections between the two halves of the network at the terminals of symmetry (at 1, 2, 3 and 4 in this example)

³ *Phil. Mag.*, Vol. 4, pp. 902-907, Nov., 1927.

the series arm of the lattice equivalent is found by short-circuiting all the terminals of symmetry of one half and viewing the network from the terminal pair of that half. Thus the series arm in the equivalent lattice network for the example chosen is as shown in Fig. 7 (d). Using the theorem the lattice arm is found by open-circuiting the terminals of symmetry and viewing from the terminal pair of one half of the network. In the example this leads to the simple lattice arm circuit shown in Fig. 7 (d).

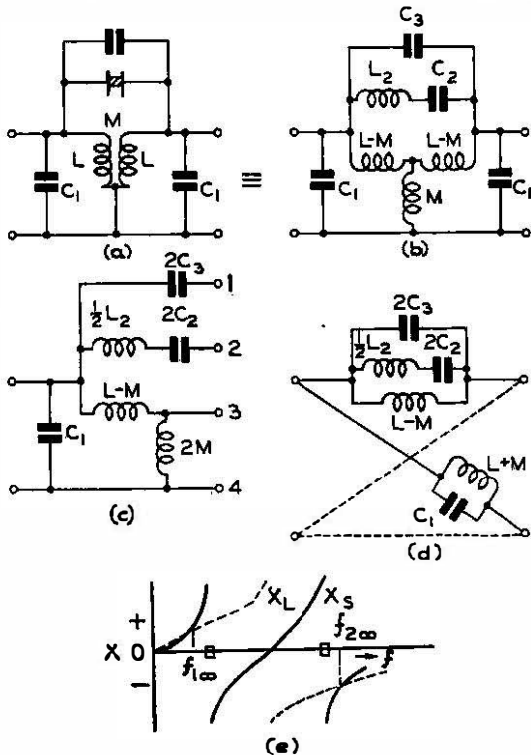

FIG. 7.—BRIDGED-T CRYSTAL FILTER AND EQUIVALENT LATTICE NETWORK FORMED BY APPLICATION OF BARLETT'S BISECTION THEOREM.

The reactance curves (see Parts 1 and 2) corresponding to these arms are related to each other, as shown in Fig. 7 (e). This arrangement yields a band-pass filter having a mid-shunt constant-K type of

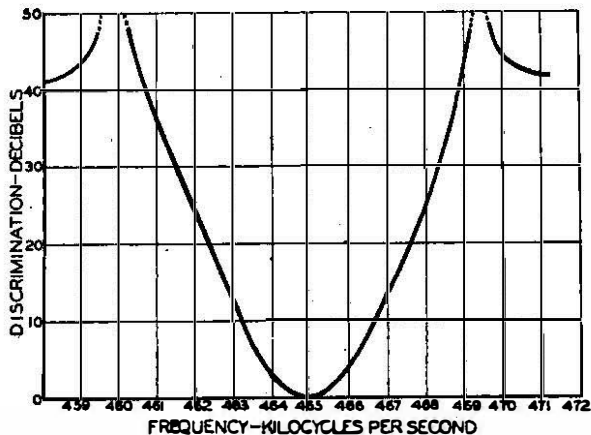

FIG. 8.—MEASURED DISCRIMINATION OF 465 KC/S I.F. CRYSTAL FILTER.

impedance and two peaks of loss. A measured characteristic of a filter is shown in Fig. 8. This filter, designed for use as an I.F. filter in a radio receiver, has a mid-band frequency of 465 kc/s and a bandwidth of about 1 kc/s and requires resistive terminations of about 250,000 Ω . The type can be designed to have a somewhat wider band if desired. Fig. 9 shows a view of the component

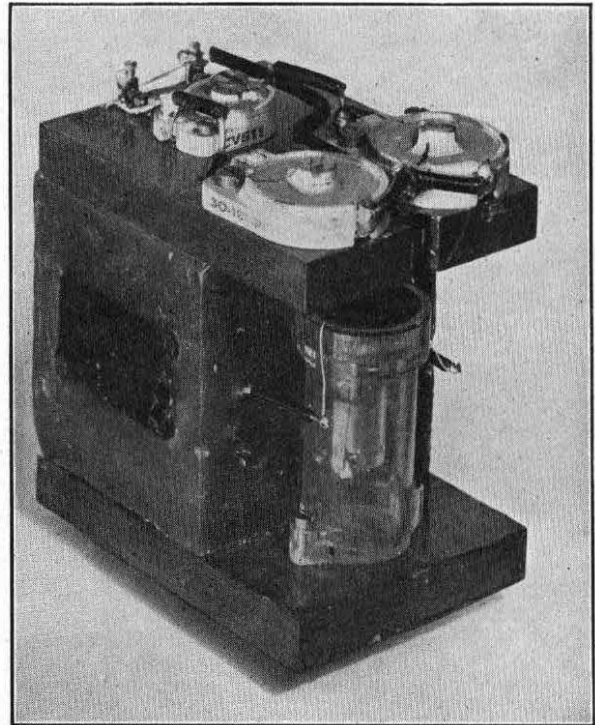

FIG. 9.—INTERMEDIATE FREQUENCY CRYSTAL FILTER (465 KC/S) FOR RADIO RECEIVER.

assembly removed from its screening case, for a filter having a loss characteristic similar to that shown in Fig. 8. The dimensions of the X cut resonator is about 0.5 cm. and the resonator is clamped within the transparent holder. The transformer and fixed capacitors are embedded in the wax between the two platforms. Three preset ceramic capacitors fitted to the upper platform are for adjustment purposes. The overall height of the assembly is 8 cm.

Crystal Filters with Wider Pass-bands — Channel Filters

An important use of crystal filters is as channel filters for carrier and radio telephone systems. For these purposes the pass-bands are usually required to be about 3 kc/s wide and to have an insertion loss which is very constant over the greater part of the band, combined with a rapid rise of insertion loss at frequencies outside the band. In carrier systems employing crystal channel filters the channels occupy the band of frequencies between 60 and 108 kc/s in which a group of 12 channels are accommodated. The filter sections so far described are not capable of yielding sufficient bandwidth for this class of work for which the so-called channel filter

has been developed. The necessary bandwidth is achieved by connecting an inductor in series with a resonator in each arm of a lattice network. The effect on the arm reactance of an additional inductor in series with a resonator is to introduce a second resonant frequency so that the reactance curve for each arm is of the form shown in Fig. 10 (a). By

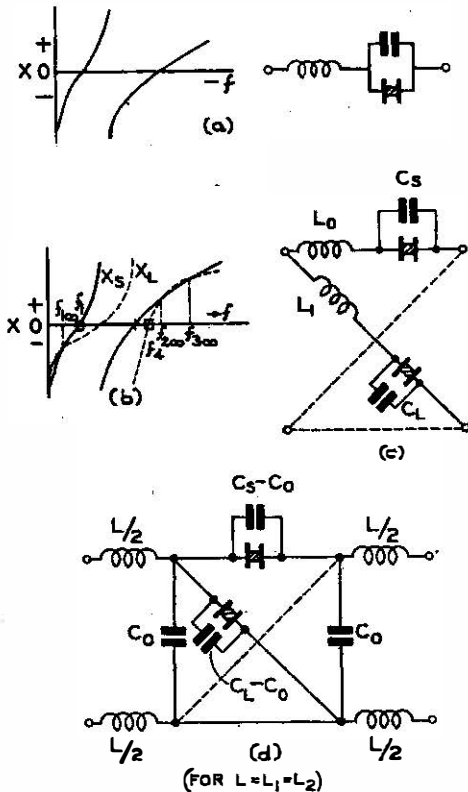

FIG. 10.—DEVELOPMENT OF CHANNEL FILTER SECTION.

associating two such curves together in the manner shown in Fig. 10 (b) a continuous pass-band can be produced between the cut-off frequencies f_1 and f_2 . Examination of Fig. 10 (b) using the principles set out in Part 2 shows that a lattice section with arms having these reactances would have a mid-series constant-K type of impedance and up to three peaks of attenuation. The network corresponding to Fig. 10 (b) is shown at (c). A total of four separate inductors is required for this circuit, but by making the inductors in each of the four arms equal to L considerable simplification and economy may be effected. Applying the transformation illustrated in Part 1 when the inductors are all equal the lattice network can be reduced to the equivalent circuit shown in Fig. 10 (d), in which four equal inductors are connected in series with the terminals of a lattice network containing four crystals. Adjacent coils can be wound together on the same core and therefore only two separate inductor cores, each with two windings, are required for a section. A theoretical analysis of the channel filter section has been published⁴, in which it is shown that to make

⁴ P.O.E.E.J., Vol. 31, p. 254.

the inductors equal in order to carry out the rearrangement shown in Fig. 10 (d) all that is necessary is to place one of the three frequencies of peak loss at infinite frequency. In the usual application of the channel filter the remaining two peaks are placed one on each side of the pass-band to give an insertion loss curve of which Fig. 11 is typical of a single section for a filter in the band 76 to 80 kc/s.

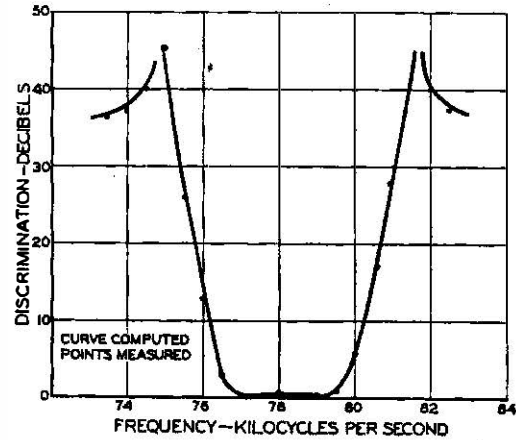

FIG. 11.—MEASURED AND COMPUTED DISCRIMINATION OF CHANNEL FILTER SECTION.

A further point of interest in the circuit of the channel filter section is the way the capacitance C_0 is removed from the series and lattice arms (after the inductors have been extracted) and placed across the terminal pairs of the lattice portion of the circuit,

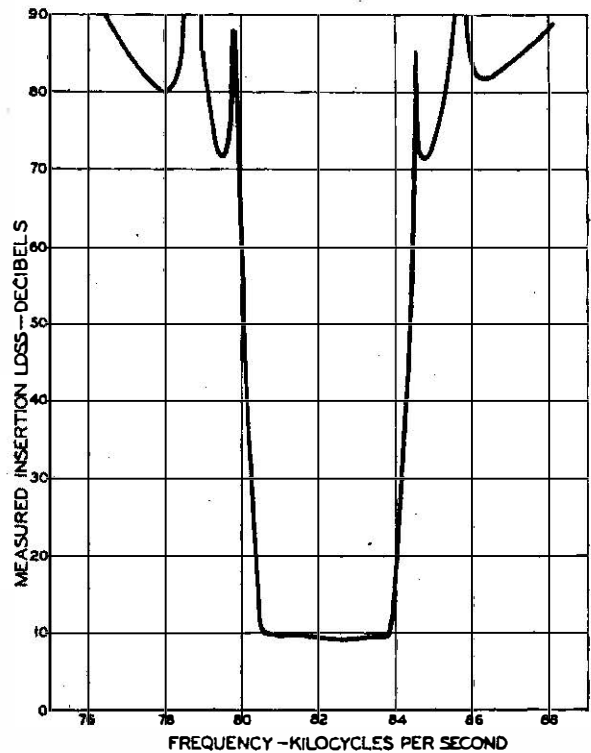

FIG. 12.—MEASURED INSERTION LOSS CURVE OF CHANNEL FILTER FOR 80 TO 84 KC/S BAND.

Fig. 10 (d). This is an example of the circuit transformation shown in Part 1. A practical advantage of this is that two instead of four relatively large capacitors are required for each section.

Channel filters, as used in coaxial systems, consist of two sections connected in tandem. The two peaks of loss of the sections are staggered so that the filter has two peaks of loss on each side of the pass-band. A measured insertion loss curve of a channel filter in the band 80 to 84 kc/s is shown in Fig. 12.

A channel filter of the same type, but with two available peaks of loss in each of the three sections placed on the same side of the pass-band, has been designed for use in a single sideband radio receiver. The typical loss curve, Fig. 13, shows the pass-band

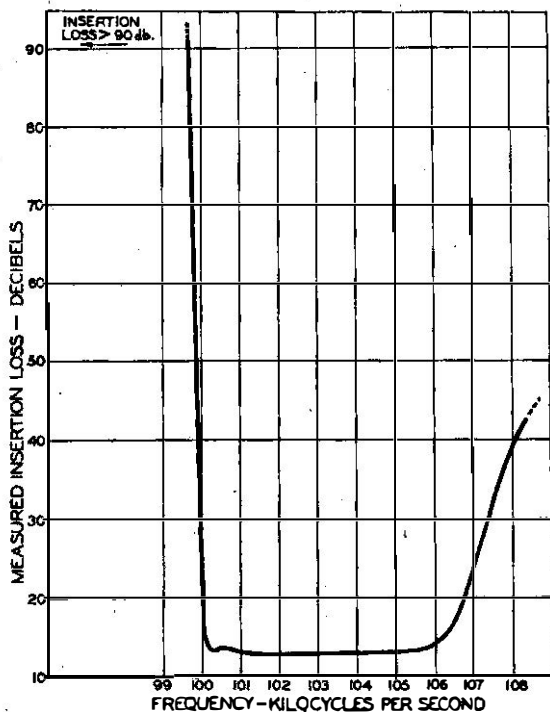

FIG. 13.—CHANNEL FILTER FOR SINGLE SIDEBAND RADIO RECEIVER—MEASURED INSERTION LOSS CURVE.

nearly 6 kc/s wide and the loss rising sharply at 100 kc/s. A tandem connection of three sections was necessary in this application to build up sufficient discrimination against frequencies below 100 kc/s, where, if desired, a second channel can be located and selected with a similar filter in which the peaks of loss are at the upper edge of the pass-band.

Resistance in the inductors of the channel filter is allowed for⁴ by making the effective series resistance of the inductors form part of the terminations for the section. When two or more sections are connected in tandem, allowance for inductor resistance at the junction of two sections is made by connecting a suitable resistance in shunt at the junction so as to form with the resistance of the coils an H pad of suitable impedance. Both methods of allowing for resistance introduce a nearly constant loss of 4 to 5 db. per section, but the dissipation of the coils is prevented from disturbing appreciably the shape of the

insertion loss characteristic which is sensibly the same as for the computed curve of an ideal filter. Measured and computed discriminations for a single section are compared in Fig. 11.

A Wide-band Crystal Filter

The last filter to be described is a wide-band pass filter, which is made of high-pass sections having a cut-off frequency of 60 kc/s connected in tandem with low-pass sections cutting off at 108 kc/s. The filter, called a through group filter, has been designed for use in coaxial carrier systems to enable a group of twelve channels to be routed from one system to another at carrier frequencies. Its use provides an economical alternative to making the connections between the systems at audio frequencies when it would be necessary, with channel filters and modulators, to translate each channel from its position in the 60 to 108 kc/s band into the audio band 0 to 4 kc/s and, after connection to the second system, to return each channel to its position in the band 60 to 108 kc/s, with more channel filters and modulators. Briefly, the through group filter must have a practically uniform loss over the greater part of the band 60 to 108 kc/s, and outside this band the loss must rise rapidly in very much the same way as does the loss of the channel filter outside its pass-band. The curve in Fig. 14 is a measured insertion loss curve of a through group filter with loss plotted with respect to the pass-band loss, which is brought up to 29 db. by added pads. The filter insertion loss is allowed to fall at frequencies well away from the pass-band; this is because other filters in the systems support the through group filter in these frequency regions.

The circuit of the low-pass sections is a lattice form, Fig. 15 (a), with resonators inductively coupled to the arms. The reactance curves of the filter arms are as in Fig. 15 (b), which illustrates one of several possible ways of assembling the reactance curves to obtain a low-pass characteristic. These curves show that there are three frequencies of peak loss in addition to two corresponding to the impedance controlling frequencies in the attenuation region and that the characteristic impedance of this filter is the same as that of a series mm' derived low-pass filter.⁵ The high-pass sections are very similar to the low-pass sections; the lattice arms have the same configuration as the low-pass sections, but in the series arms of the high-pass section the windings of the transformer connected to the terminals of the lattice networks are tuned by parallel connected capacitors instead of the series capacitors of the low-pass sections.⁶

The through group filter consists of two low-pass and two high-pass sections connected in tandem. Each

⁵The mm' derived filter bears the same relationship to the m derived as the latter does to the constant-K (see Part 2). The mm' type illustrated is characterised by two impedance controlling frequencies in the attenuation band (instead of one as in the m derived type, footnote 4 of Part 2) and the impedance/frequency curve may be made to have a nearly constant value over the greater part of the pass-band. The filter is then able to give an exceptionally uniform pass-band response.

⁶B.S.T.J., April, 1940, pp. 221-248.

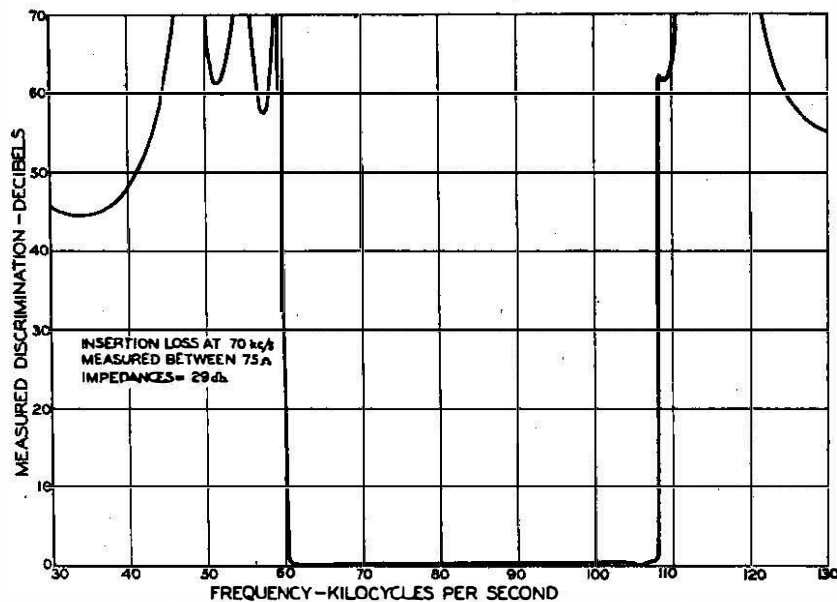

FIG. 14.—MEASURED LOSS CURVE OF THROUGH GROUP FILTER.

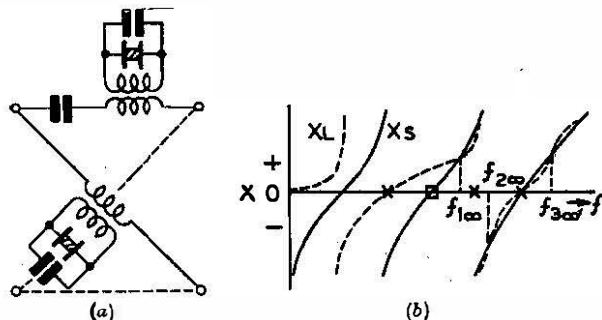

FIG. 15.—CIRCUIT AND REACTANCE CURVES OF MM' DERIVED LOW-PASS CRYSTAL FILTER.

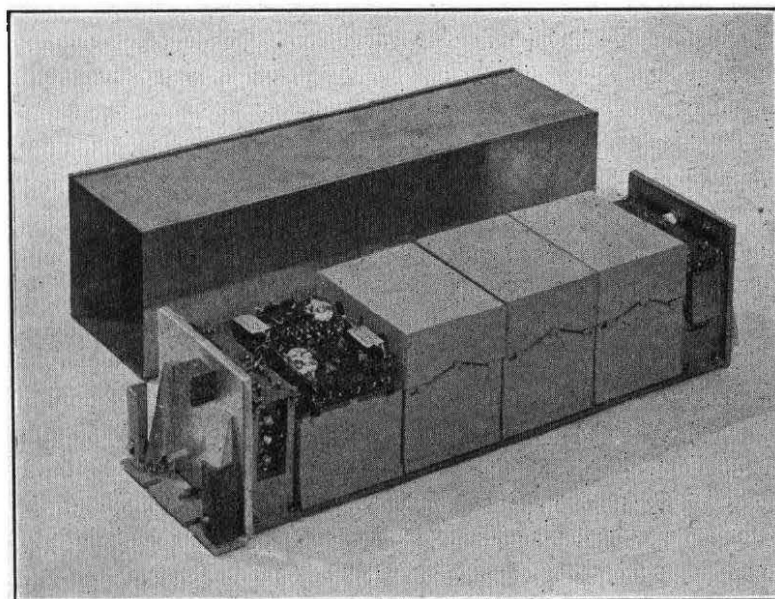

FIG. 16.—THROUGH GROUP FILTER WITH SEALING TUBE AND ONE SECTION COVER REMOVED.

section includes only two resonators, since by magnetically coupling the inductor connected to the resonator to both series arms or to both lattice arms, Fig. 15 (a), one resonator can be made to suffice for the series arms and another for the lattice arms. The appearance of a through group filter is shown in Fig. 16. The sealing tube is withdrawn and the lid of one section assembly is removed to show the general mechanical features of the filter. After the filter has been assembled and electrically adjusted the sealing tube is pushed over both end plates and soldered in position, so that both ends are airtight. Connection to the filter is made at each end by a 75 Ω coaxial cable which is terminated inside a small screening box attached to the end plate. From here a wire is passed through and soldered to a silvered ceramic bush which is itself soldered to the case. This enables the whole filter to be hermetically sealed. A small nozzle is provided on each end plate for the purpose of passing dry air or gas through the filter assembly to remove traces of moisture. When this has been done the nozzles are sealed with solder and the filter is then completely immune from the effects of atmospheric humidity.

Conclusion

The absence of any reference to ladder crystal filters in this series of articles is not to be taken as an indication that they are not used. Because of the less general nature of ladder sections relatively few have been designed. Any portion of a ladder filter section having the same configuration as the equivalent circuit of a resonator may, however, be replaced with a resonator provided the design parameters for the section are chosen to yield a resonator with practicable dimensions. Apart from this the design methods follow normal ladder filter practice.

Acknowledgments

The author is indebted to Messrs. E. R. Broad, H. Lewis and H. A. Wales for their co-operation in the electrical and mechanical design of the filters described in this article and to Mrs. J. M. Clarke for her work in computing element values, resonator dimensions and insertion loss curves for most of the designs described.

Correction.

In Part III of this series (Vol. 38, p. 40) expression $\sqrt{1/2\pi L_1 C_1}$ should read $1/2\pi\sqrt{L_1 C_1}$

The Unit Bay 1B Coaxial Cable Transmission System

R. A. BROCKBANK, Ph.D., B.Sc., A.M.I.E.E., and
C. F. FLOYD, M.A., A.M.I.E.E.

U.D.C. 621.395.44

Part 2. Intermediate Repeater Station Equipment

This is the second of a series of four articles dealing with the Unit Bay 1B Coaxial Cable Transmission System and gives a description of the more important panels of the Unit Bay used at intermediate repeater stations.

Layout

THE 660 telephone circuits carried on the standard Unit Bay 1B system are transmitted in the frequency band 60-2852 kc/s over two $\frac{3}{8}$ " diameter coaxial tubes repeatered at intervals not exceeding six miles.

These coaxial cables enter an intermediate station in ducts from below and are carried up the inside wall, where each cable is divided into its two constituent tubes and an interstice pair tail. The four coaxial tubes enter the cable termination box on the Unit Bay from overhead. The bay is connected to a normal repeater station earthing system.

At power feeding stations a power supply unit is also provided. This is arranged for mounting against the wall, and carries the incoming power supply mains-switch, meters, and a 350 V step-up transformer for connecting the mains to the coaxial power system. Unless installation charges are excessive the local

power supply is led into each station for lighting and plug points, and also to operate the Unit Bay under cable fault conditions. The provision of a telephone connected to the local exchange is a desirable facility.

The repeater equipment is mounted on a 7 ft. 6 in. high bay, as shown in Fig. 1. The panels are mounted on both sides of the bay and have dust covers 6 in. deep, finished in light grey enamel. At dependent repeater stations the panels indicated are omitted and an interlocking power switch for closing down the station in emergencies is fitted to the side of the bay. The earth system is provided by a $\frac{3}{8}$ in. diameter copper rod fixed inside the bay channel with a suitable connection to the repeater station earth.

THE H.F. CIRCUIT

The paths taken by the H.F. signals are shown by heavy lines in Fig. 2. The Go and Return circuits

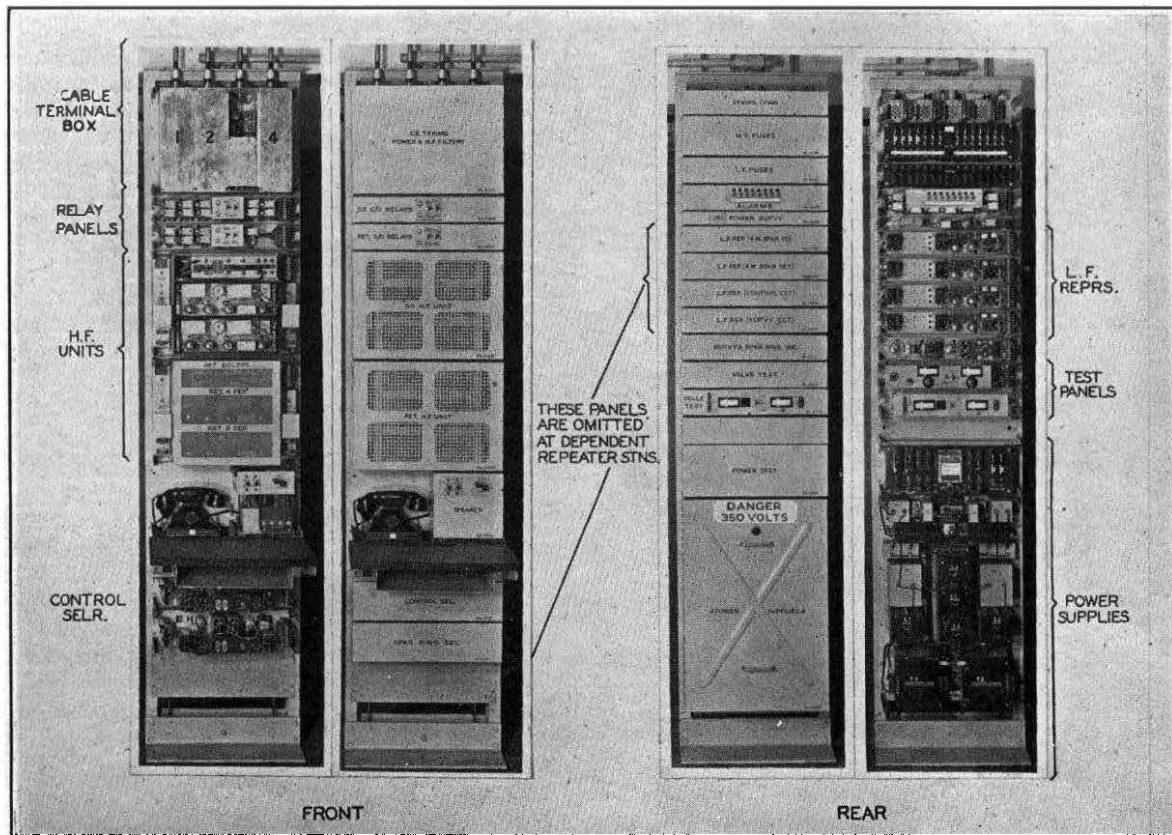

FIG. 1.—COAXIAL REPEATER EQUIPMENT. UNIT BAY 1B SYSTEM.

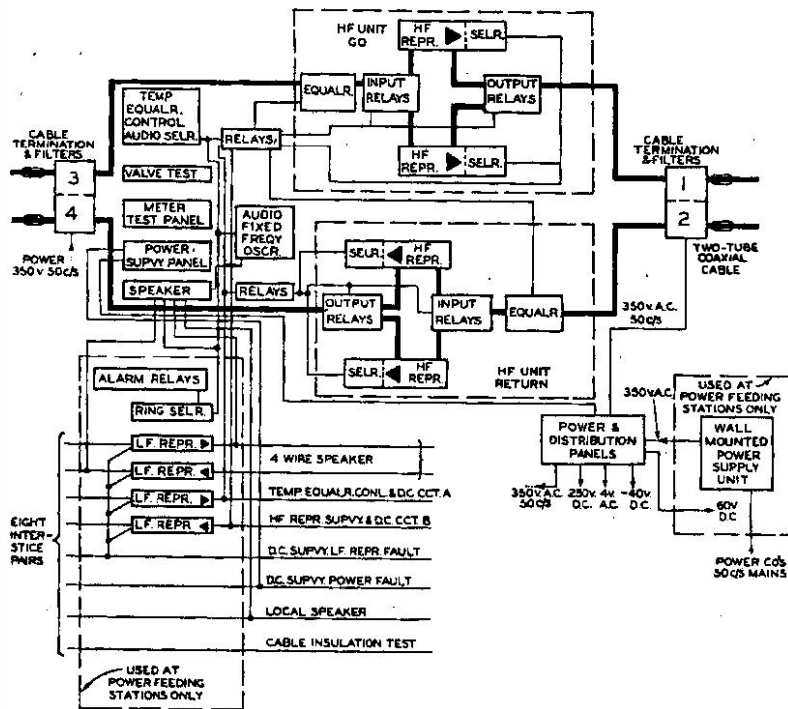

FIG. 2.—BLOCK SCHEMATIC FOR INTERMEDIATE REPEATER STATION.

are identical in design. H.F. connections are normally made with flexible double-screened coaxial cable of 75 Ω characteristic impedance. It will be seen that the H.F. circuits are entirely restricted to the termination box and the two H.F. units.

Cable Termination Box

The cable termination box, in addition to supporting and terminating the four coaxial tubes, houses filter networks, which enable 50 c/s power at 350 V A.C. to be superimposed on the inner conductors of the tubes without affecting the H.F. transmission path. The box is divided vertically into four identical compartments each containing a similar filter network. This network consists of teed high- and low-pass filter sections presenting very low attenuation to the H.F. signals and 50 c/s power respectively. Considerable care is needed in the design and construction of these filters, since at 50 c/s the two tubes are in parallel, whereas at high frequencies a crosstalk attenuation of 110 db. is required between the tubes. The loss through the H.F. filter section is less than 0.05 db. over the range of 60 kc/s to 3,000 kc/s. A screen divides each compartment and the upper section which carries 350 V A.C. is enclosed by a sliding safety cover that cannot be opened until a rotary plug has been moved to a position where it earths the centre conductor of the appropriate tube. A "U" link is fitted in each compartment at the cable head for cable testing purposes.

H.F. Unit

In any coaxial transmission equipment, freedom from mutual interference with neighbouring H.F. circuits and avoidance of unpredictable frequency

errors can be ensured only when a coaxial form of construction is maintained throughout. This is difficult to achieve in a practical form when repeaters and relays are included in the H.F. path, but a satisfactory approximation to a continuous coaxial path has been obtained by mounting the whole of the H.F. equipment for each direction of transmission on one panel and also incorporating the majority of the units inside a screened, but ventilated, copper box. The changeover relays are mounted outside the box under separate copper dust-covers. The complete unit is shown in Fig. 3.

Standard Equaliser Unit

The standard equaliser unit contains (a) the line equaliser, which consists of networks for correcting the attenuation slope of the previous cable section, (b) pads for adjusting the nominal output level of the repeater, and (c) the temperature equaliser, a network used for correcting for the variation in the attenuation characteristic of the cable due to temperature changes. The complete unit consists of a copper box, which is screwed to two long earth bars in the top compartment of the H.F. unit.

Line Equalisation.—The "slope" corrector of the line equaliser comprises five separate screened bridged T networks of 75 Ω impedance, each designed to provide correction for the frequency-attenuation characteristic of a definite length of standard $\frac{3}{8}$ in. diameter coaxial tube, and these lengths are so chosen that combinations can be connected together to equalise any cable section length between 2.8 and 6.0 miles to ± 0.1 of a mile (except at 4.4 miles, where ± 0.2 mile obtains). The average equaliser error per repeater station is about 0.1 db. Each network is built as a separate screened unit with its own soldering connection tags and is then assembled in the equaliser case. Fig. 4 shows the complete equaliser unit. The repeater output level is adjusted to the nominal value by the 2, 4, 8 and 16 db. pads.

Temperature Equalisation.—The effect of duct temperature changes on the coaxial tubes is not negligible as their attenuation is subject to a temperature coefficient of +0.28 per cent. per $^{\circ}\text{C}$. Experiments have shown that the seasonal change in temperature on a normal underground route may be as much as 20 $^{\circ}\text{C}$, which means that the electrical length of a 100 mile route may vary by the equivalent of nearly six miles of cable in a year. On the Unit Bay 1B system, the method of compensation adopted is to maintain the electrical length of the cable constant at the value corresponding to its highest temperature by adding or subtracting networks of artificial cable as the average temperature of the cable route

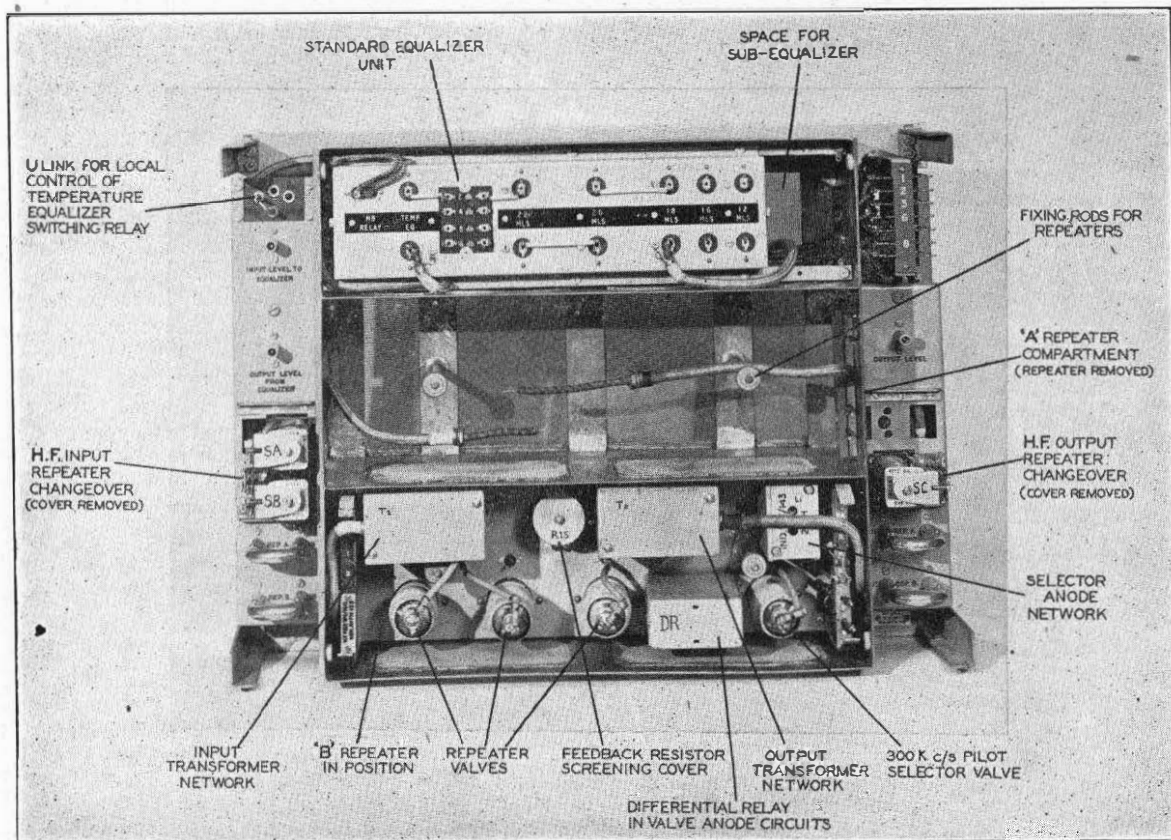

FIG. 3.—H.F. UNIT ("A" REPEATER, DUST COVERS, SCREEN AND RELAY COVERS REMOVED).

decreases or increases respectively. Each of these networks has a loss equivalent of 0.38 miles of coaxial tube, and one network is included in each equaliser unit with an H.F. relay to switch it into or out of circuit. The switching of this temperature equaliser

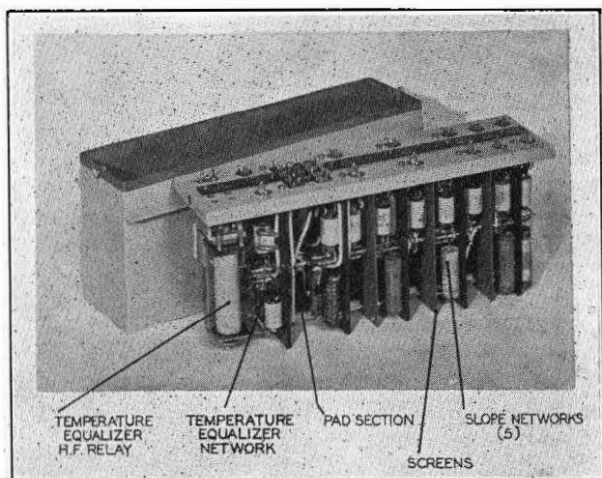

FIG. 4.—STANDARD EQUALISER UNIT.

at each station is normally carried out from the control terminal, in accordance with a pre-arranged schedule which minimises level variations along the route. This step-by-step temperature correction allows the overall level of the highest frequency

channel to vary by ± 1.5 db. if no further compensation is effected at the terminals.

H.F. Repeater

The middle and lower compartments of the H.F. Unit contain the main (or A) and standby (or B) repeater chassis respectively. Both chassis are identical and either can be removed by unsoldering the connecting leads and then unscrewing the two knurled nuts. Each repeater chassis contains a 3-valve repeater with a single-valve pilot selector teed across its output. The repeater is the result of a lengthy and complicated design process and meets the following conditions:—

- (a) The nominal gain is 48 db. and it is constant over the range 60-2,852 kc/s to ± 0.10 db.
- (b) The change in gain with 20 per cent. change in both supply voltages is less than 0.05 db.
- (c) With a 1 mW output tone the second harmonic is better than 80 db. and the third harmonic better than 100 db. below the fundamental.
- (d) Overload occurs at about 100 mW output.
- (e) The degrading of the input-signal/noise ratio due to valve noise is 3 db.
- (f) There is no perceptible change in the gain/frequency characteristic due to valve replacements.

These results are obtained by a constant loop feedback of 32 db. in the transmission band and an additional 5 db. feedback on the output valve.

Final adjustments for flatness are carried out on the components of the input and output transforming networks, which are located under the top covers of the two transformer cans, T.1 and T.2 (Fig. 3). The input and output impedances of the repeater are reactive and their values are not of importance, since the repeaters are always tested and operated between 75Ω resistive impedances.

Because of the large amount of feedback on the repeater, the gain will remain substantially unaltered, even if the emission in any valve falls to a very low value. Other characteristics of the repeater would, however, be seriously degraded, e.g. intermodulation distortion would be noticeable on the system, and to overcome this difficulty a differential relay DR. (Fig. 3) is fitted in the anode circuits of the valves, so that if the anode current of any valve in a repeater decreases appreciably the automatic repeater change over will operate.

It is important to note that a satisfactory gain/frequency response test on the repeater is no criterion that (a) it is not liable to oscillate, (b) the gain will not vary with supply volts, (c) the harmonic production may not be serious and (d) the overload point may not be low. Repairs or adjustments to repeaters should therefore be carried out only by trained staff with suitable test gear.

Pilot Selector

A pilot selector is teed on to the output of each repeater and operates from a 300 kc/s pilot tone which is transmitted over the system in each direction. If this tone fails to emerge from the "A" repeater, the selector releases and switches the "B" repeater immediately into circuit. If the selector on the "B" repeater also fails to operate, it indicates, provided the selector itself is satisfactory, either that the "B" repeater is also faulty, or that the original fault was in the cable section, termination box, or equaliser preceding the repeaters. The selector circuit is of the rectified-reaction type, using a Westector to produce the D.C. controlling voltage. Adequate selectivity against operation by traffic signals is provided by the single tuned anode circuit and by the fact that the 300 kc/s pilot level is + 3 db. relative to 1 mW, whereas each channel level is - 13 db. relative to a zero level point.

Valves, H.F. Relays and Test Points

Only one type of valve is employed throughout the whole bay. This is the long-life V.T.150, having a slope of about 8.0 mA/V with a normal anode current of 10 mA and heater consumption of 0.95 A at 4.0 V.

The "A" or "B" repeaters are switched into circuit by modified 3,000 type relays. The spring assembly, which carries the H.F. signal, consists of well-spaced 18 mil springs with twin platinum contacts and a pressure of 50 grammes. Complete reliability has been obtained over many years' service with these relays without any D.C. wetting of the contacts. It is necessary, however, to exclude dust and each relay is enclosed by a tight copper cover, which also provides adequate screening. To avoid crosstalk via the relay drive circuits, small

capacitors are connected across the tags of the coils. A similar type of relay is employed for switching the temperature equalisers in the standard equaliser unit. Fig. 5 shows an H.F. relay with its cover removed.

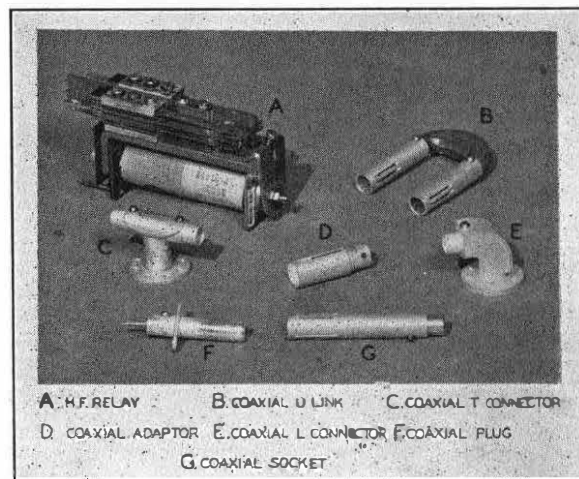

FIG. 5.—H.F. RELAY AND VARIOUS COAXIAL CONNECTORS.

Level test and disconnection points for maintenance and fault location are provided by Coaxial Plugs and Sockets (No. 1) and Coaxial U links (No. 1) (Fig. 5).

THE H.F. CONTROL SYSTEM

There are three fundamental H.F. control circuits which are included at every repeater station, viz. :—

- (a) Automatic repeater changeover in the event of failure of the "A" repeater.
- (b) Terminal control to switch into circuit any "A" or "B" repeater on the route.
- (c) Terminal or local control of temperature equalisation.

Repeater Changeover

The pilot selector which is connected to the "A" repeater monitors the output level of a 300 kc/s pilot which is transmitted over the route in each direction of transmission. The selector operates a chain of relays mounted on the relay panel above the H.F. unit. The release of the selector is taken as an indication that the "A" repeater has failed and the "B" repeater is then switched into circuit in approximately 170 mS. The circuit is, however, so arranged that if repeater changeover is caused by the failure of the pilot external to the "A" repeater, with the result that the pilot is not present at the output of the "B" repeater when this comes into circuit, then the "A" repeater is automatically restored to service if the pilot subsequently reappears at the output of the "B" repeater. The circuit thus guards against a permanent rejection of a good "A" repeater because of the failure of the pilot earlier in the system, and it is the application of this principle that restores successive "A" repeaters

into circuit when a preceding "A" repeater has failed. In short, provided the "B" repeater is not faulty on any reapplication of the pilot the "A" repeater is momentarily tested for continuity, and if found to be satisfactory, the "A" repeater is returned into circuit; if not, the "B" repeater remains in circuit. The various fault conditions are indicated by lamp signals on the bay itself and a distant alarm is registered at the control terminal against the name of the faulty station. Keys on the relay panel enable the changeover circuit to be tested and the "A" repeater locked-in at will. The Go and Return changeover circuits are quite independent at each station.

Terminal Switching of Repeaters

This facility is provided for maintenance purposes, e.g. to locate a noisy repeater, and it enables the staff at the control terminal to operate keys which change over repeaters, Go and Return together, at any repeater station on the route, or to lock-in all the "A" repeaters so that the automatic changeover is temporarily inoperative. These remote control circuits are integral with the temperature equaliser switching.

Temperature Equaliser Switching

The control terminal can switch the temperature equalisers at any repeater station into, or out of, circuit according to a prearranged schedule, by a voice-frequency selective system, operated over two interstice pairs in the cable. A different frequency chosen from the sequence 300, 420, 540 . . . 3,060 c/s, is allocated to each repeater station and a temperature equaliser selector panel, which comprises a rectified-reaction selector circuit preceded by a narrow band filter, is included on each Unit Bay. The appropriate tone from a bank of voice-frequency oscillators at the control terminal can be transmitted along a supervisory pair, which is repeated at power-feeding stations, to operate the correct station selector. This provides the means for choosing the required station on the route. The precise function which has to be performed must also be signalled and this is done by applying one or two D.C. signals from the control terminal over two D.C. circuits which are superimposed on the temperature equalisation (D.C. circuit "A" Fig. 2) and H.F. repeater supervisory (D.C. circuit "B," Fig. 2) repeated pairs. These D.C. potentials are also repeated at each power feeding repeater station. Relay circuits on each Unit Bay can then set up the conditions necessary for the required type of H.F. switching to occur. The voice-frequency signals, together with the appropriate D.C. combination, must then be applied together for about 3 seconds to effect the H.F. switching, and as soon as the signals are removed all the circuits become locked and are immune from any normal interference on the interstice pairs.

The facilities obtained and the appropriate circuit arrangements are as follows:—

- (1) To switch Go and Return Temperature Equalisers in at any one station. Voice Frequency selects the station concerned. D.C. on Circuit "B."

- (2) To switch Go and Return Temperature Equalisers out at any one station. Voice Frequency selects the station concerned. D.C. on Circuits "A" and "B."
- (3) To change from "A" to "B" repeaters at any selected station. Voice Frequency selects the station. D.C. on Circuit "A."
- (4) To lock in all "A" repeaters simultaneously independent of the 300 kc/s pilots. D.C. on Circuit "B."

SUPERVISORY SYSTEM

The large number of repeater stations on a coaxial system makes centralised fault signalling desirable and on the Unit Bay system all control facilities and supervisory indications are located at the control terminal, which is thus fully aware at all times of the condition of the route and can originate any necessary maintenance work.

Repeater Changeover

An L.F. oscillator is provided on each Unit Bay and is given the same frequency as has already been allocated to the station for the temperature equaliser selector. When both Go and Return "A" repeaters are working the output of this oscillator is fed into the H.F. repeater supervisory pair, which is repeated for the transmission of the band 300 to 3,000 c/s from remote to control terminals. Changeover of either repeater at a station cuts off this outgoing tone and at the control terminal a bank of tuned selectors similar to those used for temperature equaliser selection interprets the loss of tone as a repeater fault at that station and indicates the condition on a lamp. Three features of this system are that (a) a unique indication is given for each station, (b) any type of fault in the supervisory equipment and transmission path will call attention by giving a repeater fault alarm and (c) only one interstice pair in the cable is needed for all repeaters on the route.

Power Supervisory

Every repeater station signals an alarm to the control terminal should any one of the supply outputs from the power panel fail. This alarm is originated by the small power supervisory panel, shown at the rear of the bay in Fig. 1, which consists of a single valve with an anode relay held operated when the heater volts, anode volts and grid volts on the valve are normal. Should any one or more of these fail, the relay releases and places a short-circuit on a non-repeated interstice pair allocated to the function of power supervision for the whole route. An alarm relay operates at the control terminal and the faulty station is then located by a calibrated bridge circuit provided on the D.C. supervisory panel. The power supervisory panel is fitted with a plunger key which simulates a power fault condition for testing the D.C. supervisory circuit.

Speaker Circuits

Two speaker circuits are provided on the system. The first is a 4-wire high-grade circuit repeated at power-feeding stations which provides normal

communication with selective ringing between these stations. The ringing tone is obtained from the same oscillator that provides the H.F. repeater supervisory tone. At dependent stations a receiver and a transmitter can be connected across the circuit with a reversing key for UP or DOWN communication and the attention of the control terminal is obtained by operating the plunger key on the power supervisory panel. This 4-wire speaker from dependent stations is primarily used for reporting maintenance to the control terminal. Communication between intermediate stations is normally effected by the second speaker circuit, which is an omnibus 2-wire circuit with hand-generator ringing and dry cells for the transmitter. Communication is possible over about 30 miles.

L.F. Repeaters

The functions of the four L.F. repeated circuits required for supervisory transmission can be seen in Fig. 2. The 2-valve feedback repeaters covering the band 300-3,000 c/s are only fitted at power-feeding stations and are preceded by Equalisers No. 9A. The valves are fitted with monitoring anode relays which, in the event of valve failure, place a short-circuit on an interstice pair. This enables the fault to be located on the D.C. supervisory panel at the control terminal.

POWER SYSTEM

Power-feeding stations obtain power directly from the local Power Companies' mains. Each of these stations is, however, provided with an Austin-lite standby power plant consisting of a high speed Diesel engine coupled to a 5 kW, 50 c/s alternator. The plant is started by a motor operated from a 15 cell battery and the alternator automatically takes over the coaxial power load within 15-20 seconds of the failure of the main power. Alarm extensions are provided, but the plant is capable of running for 24 hours without refuelling.

Power Panel

Fig. 6 shows the power equipment which is mounted on the rear of the bay (Fig. 1) for providing the following supplies to the Unit Bay :-

- (a) 250 V D.C. 0.45 A.
- (b) 4 V A.C. 31 A.
- (c) 40 V. D.C. 0.25 A.
- (d) 60 V. D.C. 60 mA.

The corresponding loads for (a) and (b) at dependent stations are about 30 per cent. less than these figures. The 60 V supply, which is balanced to earth, is only required at power-feeding stations, where it energises the superimposed D.C. control circuits. An improved

reliability is obtained by working all components considerably below their specified voltage and wattage limits. The ventilated dust cover which carries a danger notice and a red lamp power indication is attached by two screws, which prevent its casual removal.

Distribution Panel

This panel carries the bay distribution points and fuses for the 250 V, 4 V, 60 V and 40 V supply circuits and the 350 V fuses to the supply transformers and the four coaxial tubes. It also contains the link box in which power connections are made to the UP and DOWN tubes; insulating dummy links are fitted where power connections are not required and in either case individual links are clearly engraved to show their specific functions. It is very important when power is removed during the clearing of a cable fault that incorrectly marked or substitute links should not be employed.

Fuse Panels

Separate 250 V and 4 V panel fuses are employed so that all panel power distribution is made from individual fuses at the top of the bay. These provide the power isolating points necessary during the clearing of bay faults.

TEST PANELS

A valve test panel operating from a 50 c/s input signal and calibrated on mutual conductance and anode current is provided at each station. An L.F. and D.C. test panel is fitted to measure power and L.F. supplies.

Two power outlets are mounted on the bay for feeding portable test equipment.

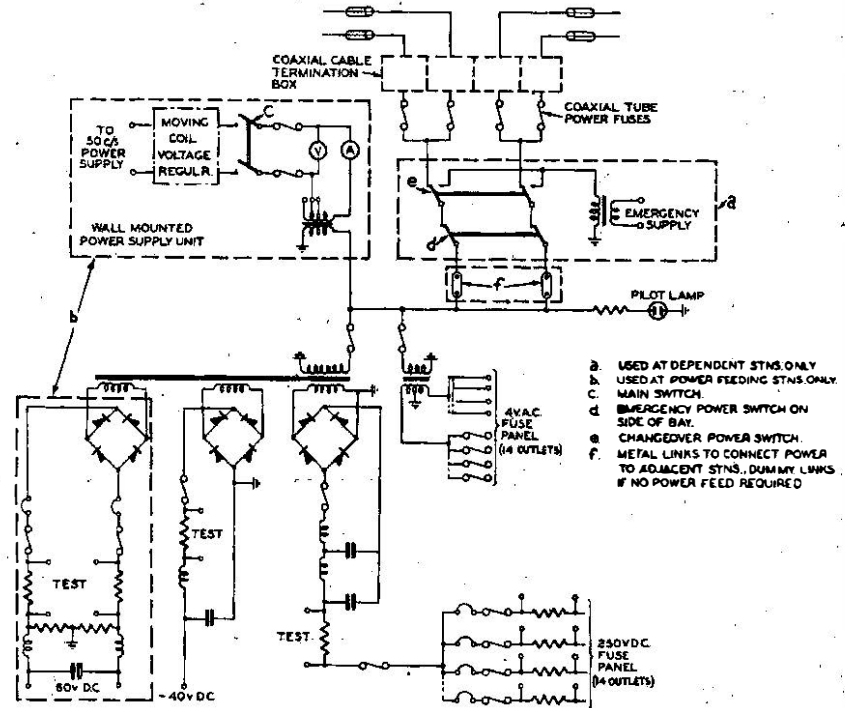

FIG. 6.—POWER DISTRIBUTION ARRANGEMENTS.

Notes and Comments

Roll of Honour

The Board of Editors deeply regrets to have to record the deaths of the following members of the Engineering Department :—

While serving with the Armed Forces.

| | | | |
|-------------------------------------|------------------------|-------------------------------|--|
| Bedford Telephone Area .. | Patmore, G. H. .. | Unestablished Skilled Workman | Gunner, Royal Artillery |
| Birmingham Telephone Area | Bishop, A. W. .. | Skilled Workman, Class II .. | Pilot Officer, R.A.F. |
| Birmingham Telephone Area | Dawson, P. J. .. | Unestablished Skilled Workman | Sergeant, R.A.F. |
| Birmingham Telephone Area | Green, T. W. .. | Skilled Workman, Class II. .. | Sergeant, R.A.F. |
| Birmingham Telephone Area | Lewis, J. F. .. | Skilled Workman, Class II .. | Flight Sergeant, R.A.F. |
| Birmingham Telephone Area | Sandall, B. .. | Unestablished Skilled Workman | Sergeant, R.A.F. |
| Birmingham Telephone Area | Twining, S. G. .. | Unestablished Skilled Workman | Pilot Officer, R.A.F. |
| Bournemouth Telephone Area | Patch, J. W. .. | Unestablished Skilled Workman | Petty Officer Airman, R.N. |
| Brighton Telephone Area .. | Rollison, C. F. .. | Skilled Workman, Class II .. | Captain, Royal Signals |
| Bristol Telephone Area .. | Apperley, W. W. .. | Skilled Workman, Class II .. | Driver, R.A.S.C. |
| Bristol Telephone Area .. | Curtis, W. F. T. ... | Unestablished Skilled Workman | Signalman, Royal Signals |
| Canterbury Telephone Area | Coleman, R. F. .. | Skilled Workman, Class II .. | Sergeant, R.A.F. |
| Engineering Department .. | Frobisher, E. F. H. .. | Skilled Workman, Class II .. | Lieutenant, Royal Signals |
| Engineering Department .. | Stringer, R. .. | Unestablished Skilled Workman | Flying Officer, R.A.F. |
| Glasgow Telephone Area .. | Winter, J. .. | Skilled Workman, Class II .. | Sergeant, R.A.F. |
| Guildford Telephone Area.. | James, A. E. .. | Skilled Workman, Class II .. | Lance Corporal, Royal Signals |
| Guildford Telephone Area.. | King, R. J. .. | Skilled Workman, Class II .. | Flight Sergeant, R.A.F. |
| Liverpool Telephone Area.. | Davey, J. E. .. | Skilled Workman, Class I .. | Signalman, Royal Signals |
| Liverpool Telephone Area.. | Hall, L. A. .. | Unestablished Skilled Workman | Aircraftsman, Class II, R.A.F. |
| Liverpool Telephone Area.. | Turner, L. C. .. | Skilled Workman, Class II .. | Flying Officer, R.A.F. |
| London Telecommunications Region | Armitage, H. .. | Skilled Workman, Class II .. | Signalman, Royal Signals |
| London Telecommunications Region | Bailey, F. C. .. | Skilled Workman, Class II .. | Sub-Lieutenant, Fleet Air Arm, R.N. |
| London Telecommunications Region | Butcher, K. H. .. | Skilled Workman, Class II .. | Sergeant, R.A.F. |
| London Telecommunications Region | Callen, E. R. .. | Unestablished Skilled Workman | Driver, R.A.S.C. |
| London Telecommunications Region | Derrett, D. S. B. .. | Skilled Workman, Class II .. | Flight Sergeant, R.A.F. |
| London Telecommunications Region | Dibsdall, W. J. L. .. | Skilled Workman, Class II .. | Signalman, Royal Signals |
| London Telecommunications Region | Evans, W. R. .. | Skilled Workman, Class II .. | Signalman, Royal Signals |
| London Telecommunications Region | Harrison, E. H. ... | Skilled Workman, Class I .. | Flying Officer, R.A.F. |
| London Telecommunications Region | Herbert, F. W. .. | Unestablished Skilled Workman | Sergeant, R.A.F. |
| London Telecommunications Region | Hollow, G. S. .. | Unestablished Skilled Workman | Driver, R.A.S.C. |
| London Telecommunications Region | Langston, F. A. ... | Skilled Workman, Class II .. | Sergeant, Beds. & Herts. Regiment |
| London Telecommunications Region | Lindsay, J. J. .. | Labourer | Private, Essex Regiment |
| London Telecommunications Region | Marjoram, W. A. .. | Skilled Workman, Class II .. | Lieutenant, King's African Rifles |
| London Telecommunications Region | Mooring, K. A. .. | Skilled Workman, Class II .. | Flight Lieutenant, R.A.F. |
| London Telecommunications Region | Parker, E. W. .. | Youth-in-Training | Sergeant, R.A.F. |
| London Telecommunications Region | Trant, A. D. .. | Unestablished Skilled Workman | Signalman, Royal Signals |
| London Telecommunications Region | Worts, R. J. .. | Unestablished Skilled Workman | Leading Aircraftsman, R.A.F. |

| | | | |
|--------------------------------------|-------------------|-------------------------------|-------------------------------|
| Newcastle - on - Tyne Telephone Area | Browne, W. N. .. | Skilled Workman, Class II .. | Flying Officer, R.A.F. |
| Norwich Telephone Area .. | Bryant, P. .. | Skilled Workman, Class II .. | Sergeant, R.A.F. |
| Norwich Telephone Area .. | Waddington, S. A. | Inspector | Flight Lieutenant, R.A.F. |
| Portsmouth Telephone Area | Morrison, R. M. | Unestablished Skilled Workman | Warrant Officer Pilot, R.A.F. |
| Scotland West Telephone Area | Murray, G. A. B. | Skilled Workman, Class II .. | Signalman, Royal Signals |
| Sheffield Telephone Area .. | Hardy, L. .. | Unestablished Draughtsman .. | Sub.-Lieutenant, R.N. |
| Tunbridge Wells Telephone Area | Fayers, R. C. .. | Skilled Workman, Class II .. | Flight Sergeant, R.A.F. |

Recent Awards

The Board of Editors has learnt with great pleasure of the honours recently conferred on the following members of the Engineering Department :—

While serving with the Armed Forces, or on Post Office Duty.

| | | | | |
|------------------------------|--------------------------|-------------------------------|-------------------------------|---|
| Aberdeen Telephone Area .. | Leith, W. F. .. | Unestablished Skilled Workman | Lance Corporal, Royal Signals | British Empire Medal |
| Aberdeen Telephone Area .. | Neilson, J. D. .. | Skilled Workman, Class I | On Post Office Duty | British Empire Medal |
| Belfast Telephone Area .. | Ferguson, C. H. | Draughtsman, Class II | Corporal, Royal Signals | Mentioned in Despatches |
| Belfast Telephone Area .. | McKeown, R. M. | Skilled Workman, Class II | L/Sergeant, R.E. .. | British Empire Medal |
| Birmingham Telephone Area | Cooper, H. .. | Chief Inspector .. | On Post Office Duty | British Empire Medal |
| Birmingham Telephone Area | Yerbury, R. A. | Skilled Workman, Class II | Signalman, Royal Signals | Mentioned in Despatches |
| Bournemouth Telephone Area | Faithful, A. J. .. | Inspector .. | On Post Office Duty | British Empire Medal |
| Bradford Telephone Area .. | Speechley, E. .. | Inspector .. | Major, Royal Signals | Mentioned in Despatches |
| Canterbury Telephone Area | Martin, L. J., B.E.M. | Skilled Workman, Class I | On Post Office Duty | Commended by P.M.G. |
| Cardiff Telephone Area .. | McCarthy, A. L. | Unestablished Skilled Workman | Flying Officer, R.A.F. | Distinguished Flying Cross |
| Cardiff Telephone Area .. | Rowell, P. D. .. | Skilled Workman, Class II | Sergeant, Royal Signals | British Empire Medal |
| Colchester Telephone Area .. | Williams, N. R. | Inspector .. | Captain, Royal Signals | Military Cross |
| Edinburgh Telephone Area | Macpherson, C. J. | Skilled Workman, Class II | Signalman, Royal Signals | Mentioned in Despatches |
| Edinburgh Telephone Area | Mann, J. .. | Skilled Workman, Class II | Flight Sergeant, R.A.F. | British Empire Medal |
| Engineering Department .. | King, R. E. .. | Skilled Workman, Class I | Corporal, Royal Signals | Mentioned in Despatches |
| Engineering Department .. | Leckenby, A. J. | Executive Engineer | Major, Royal Signals | Member of the Order of the British Empire |
| Engineering Department .. | Robbins, R. A. D. | Inspector .. | Captain, Royal Signals | Mentioned in Despatches |
| Lancaster Telephone Area .. | Chew, T. E. .. | Skilled Workman, Class II | Sergeant, Royal Signals | British Empire Medal |
| Lancaster Telephone Area .. | Grundy, F. E. .. | Skilled Workman, Class I | On Post Office Duty | British Empire Medal |
| Leeds Telephone Area .. | Smith, C. D. .. | Skilled Workman, Class II | Flying Officer, R.A.F. | Distinguished Flying Cross |
| Leeds Telephone Area .. | Taylor, G. N. .. | Skilled Workman, Class I | Captain, Royal Signals | Member of the Order of the British Empire |
| Lincoln Telephone Area .. | Wilkes, W. D. G., D.F.M. | Skilled Workman, Class II | Flight Lieutenant, R.A.F. | Mentioned in Despatches |

| | | | | |
|-------------------------------------|----------------------------|------------------------------|-----------------------------------|---|
| Liverpool Telephone Area .. | Burfitt, F. W. .. | Skilled Workman, Class II | Chief Petty Officer, R.N. | British Empire Medal |
| London Telecommunications Region | Brownrigg, D. W. P. | Skilled Workman, Class I | Warrant Officer, R.A.F. | Mentioned in Despatches |
| London Telecommunications Region | Chandler, D. C. | Skilled Workman, Class II | Corporal, Royal Signals | Mentioned in Despatches |
| London Telecommunications Region | Dyer, L. J. .. | Inspector .. | On Post Office Duty | British Empire Medal |
| London Telecommunications Region | Harnden, A. B. | Area Engineer | Lieut.-Colonel, Royal Signals | Mentioned in Despatches |
| Manchester Telephone Area.. | Connoly, C. F. | Skilled Workman, Class II | Sergeant, Royal Signals | Croix de Guerre with Bronze Star and Mentioned in Despatches |
| Manchester Telephone Area | McGosh, H. .. | Skilled Workman, Class II | C.Q.M.S., Royal Signals | British Empire Medal |
| Manchester Telephone Area | Scanlan, W. .. | Skilled Workman, Class II | Sergeant, Royal Signals | Mentioned in Despatches |
| Midland Region | Bish, T. A. .. | Inspector .. | Lieut.-Colonel, Royal Signals | Mentioned in Despatches |
| Midland Region | Harris, L. H., C.B.E. | Chief Regional Engineer | Brigadier | Officer of the Legion of Merit (U.S.A.) |
| Norwich Telephone Area .. | Drane, L. G. .. | Labourer | Sergeant, Royal Signals | British Empire Medal |
| Portsmouth Telephone Area | Lockwood, R. A., B.E.M. | Chief Inspector .. | On Post Office Duty | Member of the Order of the British Empire |
| Reading Telephone Area .. | Bluring, J. .. | Skilled Workman, Class II | Flying Officer, R.A.F. | Distinguished Flying Cross |
| Reading Telephone Area .. | Brown, R. .. | Skilled Workman, Class II | Sergeant, Royal Signals | British Empire Medal |
| Reading Telephone Area | Fripp, W. A. .. | Skilled Workman, Class II | Pilot Officer, R.A.F. | Distinguished Flying Cross |
| Reading Telephone Area .. | Goff, G. .. | Skilled Workman, Class I | On Post Office Duty | Royal Victorian Medal (Silver) |
| Scotland West Telephone Area | Knox, J. .. | Assistant Engineer | Major, Royal Signals | Mentioned in Despatches |
| Scottish Region | Barnett, W. J. G. | Inspector .. | Major, Royal Signals | Member of the Order of the British Empire |
| Southend-on-Sea Telephone Area | Anderson, R. H., D.F.C. | Skilled Workman, Class II | Flight Lieutenant, R.A.F. | Bar to Distin- guished Flying Cross |
| Southend-on-Sea Telephone Area | Tricker, E. C. .. | Inspector .. | On Post Office Duty | British Empire Medal |
| Swansea Telephone Area .. | Gallaghan, T. G. | Skilled Workman, Class II | Captain, Royal Welsh Fusiliers | Military Cross |
| Swansea Telephone Area .. | Williams, J. H. | Skilled Workman, Class I | On Post Office Duty | British Empire Medal |

Appointments

The Board of Editors offers its congratulations to:

Brigadier L. H. Harris, C.B.E., Chief Regional Engineer, Midland Region, who has been appointed Regional Director, Scottish Region, as from 1st November, 1945, and to:

Mr. W. T. Gemmell, who returns from the Ministry of Aircraft Production to take up duty as Staff Engineer in charge of the Power Branch of the Engineer-in-Chief's Office.

Back Numbers

The Board of Editors recently invited subscribers in the Post Office to return certain back numbers of the JOURNAL to meet demands received from subscribers returning from the Forces. The Board wishes to thank subscribers and local agents for the good response to their appeal. A reasonable stock of all parts is now held, which it is hoped will be adequate in meeting demands for back numbers, and further copies are not required at present.

Regional Notes

London Telecommunications Region A NOVEL FLOOR COVERING

The leakage of water into underground reinforced concrete structures is a familiar problem to G.P.O. engineers in spite of the stringent conditions of the relative specifications. The method adopted to counter such leakage at a large Defence Station in the London Telecommunications Region during the installation of equipment will, it is thought, be of interest.

Installation was well advanced when a pool of water appeared overnight in the power room and, later, other pools appeared in the apparatus room. As the builders sealed off one section of the floor area, using special cements, water appeared in another section. Eventually installation was suspended and the following method was adopted to prevent water affecting the equipment. The feet of apparatus racks already installed and the sites for additional racks were filled with bitumastic compound, the remainder of the floor area being covered by 4 in. square red tiles, set in cement, with 2 in. spaces between them. The tiles were then covered with waterproof building paper and on the top of this 6 in. square tiles, set in bitumen, were placed so that the corners lay over the centres of the 4 in. tiles below the waterproof paper. Waterways, thus formed, were extended through holes cut at floor level in the partition walls to sumps in the corridor, where water could be carried away.

G. A. T.

UNUSUAL REPAIR TO MOTOR GENERATOR SET

Recently when a motor generator set was in course of removal a roller supporting it slipped from under the base plate and allowed the set to fall about 2 in. The jar badly cracked the base plate. The cracked base plate is shown at the top of the photograph and its

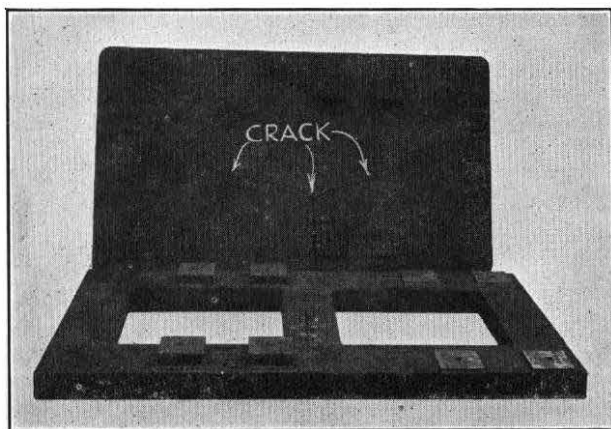

nature is indicative of a previous fault in the casting. The crack "opened-up" considerably, and as a result disturbed the fixing centres of the machines.

As a new casting was not readily obtainable, a firm specialising in welding repairs to castings was asked to estimate for the repair of the base plate by welding, and what was thought to be a very high figure was quoted. It was decided, therefore, to see what could be done in the way of fabricating a new base plate from standard M.S. sections. This was done, and the result is seen in the lower part of the photograph.

The cost of the work was considerably less than half the estimated cost of repairing the cast iron base plate. The new base was designed in the Power Section Drawing Office and built up by the arc welding process in the Section Workshops.

C. P.

UAX NO. 13 IN A TEMPORARY WOODEN BUILDING

The Shorne manual exchange (CBS No. 2) was converted to automatic working on August 29th, 1945, when 115 subscribers were transferred to a Unit Automatic Exchange Type 13, installed in a wooden hut.

It was necessary to remove the CBS2 exchange from the Post Office at short notice. The estimated ultimate growth in the exchange area required a UAX14, but in present circumstances it would have been a year, or two, before a standard UAX14 building would have been completed. As, however, the 10-year development could be met by a UAX13, for which a suitable wooden hut was available, it was decided to install a UAX13.

The hut was erected on a concrete raft on the exchange site clear of the permanent building position. Fig. 1 illustrates the methods of construction used

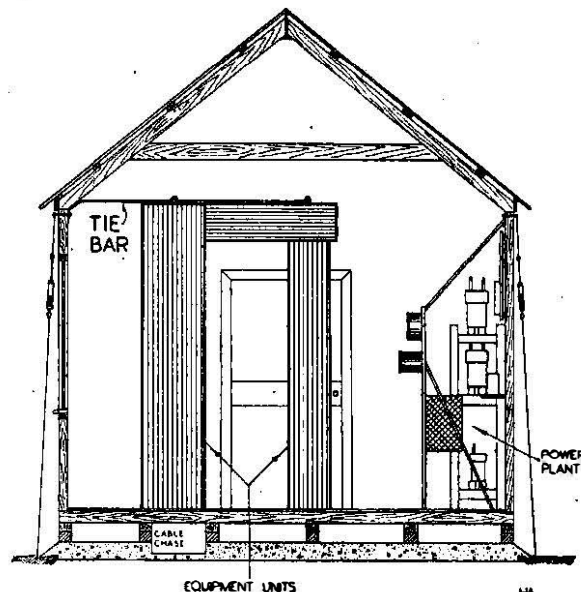

FIG. 1.

and Fig. 2 shows a general view of the hut. The fabric of the hut is wooden planking and is lined on the inside with uralite. The roof is covered with tarred felt. The floor is mounted on brick piers in the line of the apparatus racks and is covered with lino. The stay wires, shown in the diagram, are to anchor the hut securely to the concrete raft.

The equipment installed comprises 4 subscribers' units, 5 junction units and the main frame unit, together with the standard UAX 13 power equipment, which gives a capacity of 200 subscribers' lines. A total of 23 unidirectional junctions with associated route discriminating and multi-metering equipment was accommodated in the junction units.

The hut is fitted with tubular heaters of 1.5 kilowatts total capacity, with a humidistat control. The site is fairly well drained, but the position is very exposed.

There has, however, been no evidence of any dampness inside the hut and the normal insulation standards have been fully maintained.

This is the first UAX which has been installed in a temporary building in the London Region and it is thought in the country. The result appears most



FIG. 2.

satisfactory, and no doubt considerable use can be made of similar temporary buildings in other cases when the building position is likely to delay seriously the conversion or provision of new unit automatic exchanges.

S. M. E. R.

North-Western Region

THE ROYAL VISIT TO MANXLAND

The recent visit of Their Majesties the King and Queen to the Isle of Man in July was of historical importance for the island, as over 500 years have elapsed since a King presided over the ancient Tynwald ceremony. This open-air ceremony, which takes place at the Tynwald Hill at St. Johns on July 5th each year, marks the opening of the Manx Parliament. All the laws which have been enacted during the previous year are "proclaimed to the people" in the English and Manx languages.

The Royal visit also made history for the Engineering Department and the Press, as it was the first occasion on which successful "picture transmissions" had been carried out from the Isle of Man. Actually, the first picture was transmitted on Sunday July 1st, 1939, for the *Daily Mirror*.

Something like 30 newspaper reporters and photographers were covering the Royal visit and three mobile picture transmission sets were employed. As only 11 trunk circuits are available between the island and the mainland, a press conference was held to arrange the call bookings. It was agreed that two circuits would be made available for picture transmissions when required. One circuit (Douglas-Manchester) was to be used for the Manchester offices of the *Daily Mail* and *Daily Express*, and the remaining circuit, which had to be extended to London for the *Daily Mirror*, consisted of a Douglas-Liverpool and a Liverpool-London trunk switched 4 wire at Liverpool. The *Daily Mail* and *Daily Express* representatives agreed that they would alternate first and second choice for each daily series of transmissions to Manchester. This meant that at Manchester repeater station the local ends to the respective newspaper offices had to be switched as soon

as a picture transmission had been completed, and at Liverpool the Douglas circuit had to be extended, when required, to London for the *Daily Mirror*.

The booking and switching arrangements worked without a hitch. Arrangements were made for the trunk circuits to be brought out on flexible connections at the repeater rack test jacks at Douglas exchange and the mobile transmission sets were placed on tables facing the rack. Thus, the sets could be connected in a matter of seconds when transmissions were required, as speed is essential in setting up the circuits when the calls mature, and the exchange equipment cut out of circuit.

Picture transmission usually took place about mid-day and between 6 to 7 p.m., and on these occasions the *Daily Mirror* set would be transmitting simultaneously with the *Daily Mail* or *Daily Express*.

Accommodation was provided for the photographers and "telephoto" operators in a portion of the exchange outbuildings, in which they erected their portable dark rooms for developing their plates and making 8 in. by 5 in. enlargements required for the portable sets. It might be of interest for amateur photographers to know that the developing and enlarging process was usually completed within 10 minutes. Also, the transmission of a picture takes approximately 10 minutes. Thus, exposed plates brought into Douglas exchange were developed, printed and reproduced as positive prints in London in just over 20 minutes.

During the Royal visit 57 pictures were transmitted and not one failure was experienced.

A further point of interest is the manner in which the pictures of the Royal visit were printed in *The Isle of Man Weekly Times*. Due to local difficulty in obtaining "blocks" for the half-tone reproduction in the newspaper, arrangements were made whereby the *Daily Mirror* in London agreed to make the blocks from the pictures transmitted by the mobile set at Douglas. The blocks were flown back by the normal civil air lines to Liverpool and then to the Isle of Man and were in possession of the *Isle of Man Times* in less than 24 hours after the pictures were taken.

In addition to the picture transmission aspect of the Royal visit the Department's staff carried out the wiring from the various microphone points for the B.B.C. recording unit at the Royal Tynwald ceremony. Also, additional teleprinter P.W.'s were provided between certain points on the island and between the island and the mainland.

H. G. C.

CUTTING DOWN 65 FT. STOUT POLE.

WIGAN, ASHTON-IN-MAKERFIELD OLD TRUNK ROUTE.

While engaged on the recovery of spare wires from the old Wigan, Ashton-in-Makerfield trunk route, it was found that one 65 ft. stout pole was badly decayed from a point 38 ft. above ground level to the top of the pole. The pole, carrying 10 arms, fully equipped with spindles, insulators, and 150 lb. copper wire, was unsafe to climb. It was situated on the narrow foot-path on the main North to South road, close to the side of a dwelling house. To erect derricks would have involved diverting all road traffic. Various methods of tackling the job were considered and turned down because of the risk of accident.

Acting on a suggestion made by the local inspector the N.F.S. were approached and they agreed to loan the turntable fire escape ladder. At first the N.F.S. conditions of the loan included that the N.F.S. men should cut down the decayed portion of the pole, but when the difficulties of the job were realised, they

agreed to allow the Post Office engineers to climb the ladder, much to the satisfaction of the gang. The gang, consisting of four men, fixed blocks and tackle to the top of the ladder. Two men were stationed near the top and two men on the ground operated the rope. Before cutting began, working wires were pieced out and reterminated on new arms fitted lower down the pole. The other wires were recovered. Four N.F.S. men came with the fire escape and were employed as follows: one man stood by a nearby telephone, ready for any emergency fire call; another controlled and directed the traffic, which was very heavy and the N.F.S. vehicle occupied half the available road space; the other two men manipulated the ladder. The wiremen took a little time to become accustomed to using the telephone at the top of the ladder and frequently followed the normal practice of shouting directions to the men below. Repeated changes in the position of the ladder had to be made. It had to be raised to allow the men to attach the rope to the piece being cut, then lowered to enable the cut to be made. The men below had carefully to take up slack or pay out rope on each change of position. The first piece was sawn off and lowered without difficulty. It was hollow, only the outside shell and knots in the wood remaining intact. There was a bird's nest in the cavity. The second piece was fully equipped with eight arms and fittings, which were in such a condition that it was impracticable to dismantle them before recovery. The men had to use the saw left-handed, and it jammed frequently. When the piece was about to break off, the N.F.S. were asked to raise the ladder to enable the rope to take the strain. At the moment when the break occurred there was a gust of wind and the top of the ladder whipped sharply and the men below had difficulty in holding on to the rope. After this, it was found that there was a winch on board the vehicle which assisted materially in the later operations.

The operations commenced at 2.30 p.m. and were completed satisfactorily at 5 p.m.—a very risky job completed in good time with a four-man gang. The N.F.S. charged a nominal fee of 11s. 6d. A letter expressing appreciation for the co-operation was sent to the officer in charge of the fire station.

Welsh and Border Counties Region PAINT SPRAYING MACHINE.

The Regional Repair Depot staff in this Region has constructed an efficient paint spraying machine, mainly from old spare parts and at very little cost. The idea originated in the Bristol Repair Depot, and an effort was made to emulate the Bristol example. Briefly, the apparatus employed consists of:—

- (a) An air compressor recovered by the Motor Transport staff from a 3-ton Albion lorry scheduled for scrapping. These air compressors were used in this type of vehicle for tyre inflation when thrown into gear with the engine flywheel. The air compressor has been geared down for use with the spraying apparatus to limit its maximum output to approximately 60 lb. per sq. in. pressure.
- (b) A $\frac{1}{4}$ h.p. stamp cancelling machine electric motor of an obsolete pattern for driving the air compressor via suitable gearing. The gear wheels were part worn items recovered from stamp cancelling machines during overhaul.
- (c) An air receiver comprised of a fire extinguer container. This is fitted with a safety valve, releasing at 40 lb. to the sq. in., together with a pressure gauge obtained from scrapped items.
- (d) A paint spraying gun purchased locally at a cost of £6 16s. This has been connected to the

air receiver with some 14 ft. of partially worn rubber hose thrown spare by renewal of the hose on the lead burning plant in use at the Depot.

The whole of the equipment has been mounted on a steel plate with framework and bolted to a small bogey chassis to give mobility. Approx. 50 ft. of 3-core V.I.R. cable is attached for connecting the set to the nearest power point. This permits spraying to be done in the yard outside the workshop when necessary.

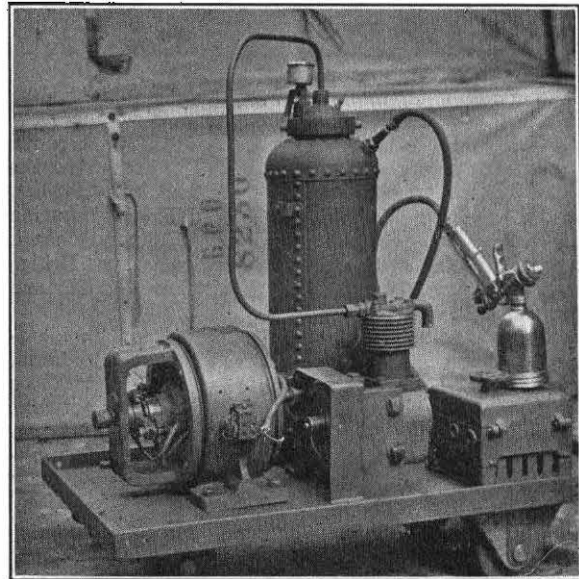

This apparatus has been found extremely useful and economical in manpower in spraying office machinery after overhaul and steel framework, panels, etc., constructed in the workshop. R. R.

Home Counties Region

"A SATISFIED SUBSCRIBER."

It should not, of course, be suggested that a satisfied telephone subscriber is a rarity, but it may be that the extreme satisfaction reflected by the following incident is unusual.

A fault docket received in the Portsmouth Area Maintenance Control bore this rather equivocal statement—"Please overhaul, as telephone has not been seen for 17 years."

It was found on investigation that the subscriber concerned (on the Petersfield C.B.10 exchange) had not had a visit from anyone connected with the telephone service since the instrument was installed in 1929. It transpired that this circuit sustained two interruptions in 1930, one being a cable fault and the other an exchange fault, both of short duration. There was one exchange fault in 1932 and another in 1935 and none since that date, despite the almost universal "freeze-up" in the locality early in 1939, and the unwelcome but happily infrequent attentions of the Nazi Luftwaffe during the war years. Obviously, a visit to the subscriber's premises was unnecessary on any of the faults recorded.

The sequel is that the premises were visited early in 1945 as a result of the report referred to above, and the installation was found in perfect order. The subscriber said that he had nothing to complain of, but thought that as he had seen no Post Office people for so long a period, it might be a good thing to get his instrument overhauled. F. J. G.

North-Eastern Region
MANCHESTER-LEEDS-NEWCASTLE COAXIAL
CABLE

(Type 4 × 375 D.T. + 10 pr/25 P.C.Q.T.)

Fault of 25 January, 1945

The extremely cold weather experienced early this year was responsible for the above cable breakdown which is considered unique. The initial report of the failure indicated that all conductors—coaxial and interstice—were faulty between Rushyford R.S. and Sunderland Bridge R.S. (Croxdale), both of which are situated in the county of Durham, just off the Great North Road, along which the cable is routed. Tests revealed that, although the four coaxial conductors were faulty, the interstice quads were up to standard in all respects. This condition was rather exceptional, and led to the assumption that collapse of the coaxial tubes had occurred without failure of the sheathing. Location tests on the faulty coaxial conductors indicated that a fault existed some 400 yards south of Sunderland Bridge R.S. in a 259-yard length of cable. This was confirmed in the normal way.

Restoration of service being the immediate consideration, temporary repairs were effected by special coaxial interruption cable, plus a length of paper core cable to cater for the interstice quads. On completion, it was decided to withdraw the faulty length of cable and, if necessary, replace it with a new length. Efforts to withdraw the cable at points A and D (Fig. 1) respectively

distance between them are in horizontal formation. This, together with the facts that the pipe was laid at a depth of 4½ in. for the greater part of its length across the bridge, and only 2 in. at places from the underside, appeared to indicate that the extremely cold weather which prevailed, plus inadequate protection of the pipe against such extreme weather conditions, had resulted in the water in the pipe becoming frozen, and in the process of freezing and the consequent expansion, the cable was flattened and its withdrawal prevented.

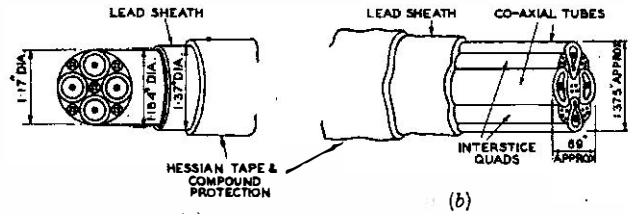

FIG. 2.—(a) BEFORE, (b) AFTER DAMAGE.

Rodding over the cable between B and C was attempted, but obstructions were encountered 15 yards from each of the jointing chambers. Excavations were carried out at the points of obstruction and the expedient of heating the steel pipe with blowlamps was tried. This, however, was of little avail, and as prospects of withdrawal of the cable appeared very remote, operations were abandoned. On resumption of operations

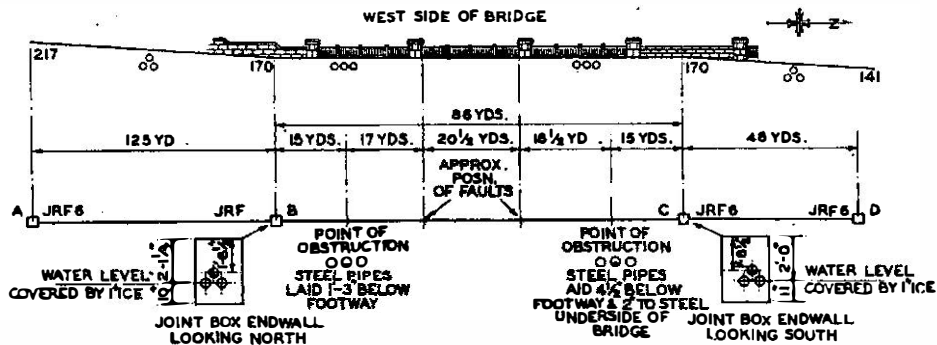

FIG. 1.—SITE OF CABLE DAMAGE.

were unsuccessful. It was thereupon decided to cut the cable at B and C, and withdraw it in three sections. No difficulty was experienced in withdrawing two of the sections, but that between B and C could not be drawn-out in spite of repeated and prolonged efforts. When the jointing chambers at B and C were opened, a layer of ice 1 in. in thickness existed on top of the water present in the boxes. The level of the water was not, however, up to the level of the pipe which contained the faulty section of cable. In view of this and the varying levels of the track, it was assumed that water had, at some time previous to the fault, lodged in the three steel pipes between B and C, at which points they are in the formation of a three-way duct, but for the larger portion of the

at a later date, no difficulty was experienced in drawing-out the remaining section of cable. After withdrawal of the cable, it was observed that two portions, one 3 ft. in length and the other 2 ft. in length, were flattened. Fig. 2 indicates the damaged cable, and, for comparative purposes, the cable as it was originally is also shown.

Before drawing-in the new length of cable, a brush and mandrel were drawn through the section of pipe in which the trouble occurred. No obstructions were encountered, but it was noted that there was a considerable flow of water from the pipe as the brush and mandrel progressed from one end to the other.

All observations indicated that the damage was due entirely to the formation of ice in the pipe. J. A.

Staff Changes

Promotions

| Name | Region | Date | Name | Region | Date |
|----------------------------------|----------------------|----------|--|-------------------------|---------|
| <i>A.S.E. to Dep. C.R.E.</i> | | | <i>Mech. Grade I to Tech. Asst.</i> | | |
| Harbottle, H. R. | E.-in-C.O. to L.T.R. | 1.7.45 | Worthington, J. S. | Mount Pleasant to Leeds | 8.7.45 |
| <i>Asst. Eng. to Exec. Engr.</i> | | | ** White, N. C. | Plymouth | 14.6.45 |
| Riley, C. | H.C. Reg. | 1.6.45 | Elder, D. | Bristol to London | 14.6.45 |
| Langford, L. C. | L.T.R. | 7.6.45 | <i>Draughtsman, Class I, to Senior Draughtsman</i> | | |
| <i>Insp. to A.T.S.</i> | | | **Stewart, R. J. | Scot. Reg. | 2.8.42 |
| Hickey, J. T. | L.T.R. | 11.4.45 | Hind, B. C. | E.-in-C.O. | 1.6.45 |
| Glaysheer, R. E. | L.T.R. | 18.4.45 | <i>Draughtsman, Class II, to Draughtsman, Class I.</i> | | |
| <i>S.W.I. to Insp.</i> | | | **Daggett, T. K. | E.-in-C.O. | 22.7.45 |
| Blunden, R. M. | E.-in-C.O. | 20.8.44 | Eakin, G. W. A. | E.-in-C.O. | 22.7.45 |
| Bubb, E. L. | E.-in-C.O. | 10.12.44 | | | |

** In absentia.

Transfers

| Name | Region | Date | Name | Region | Date |
|--------------------------------|--------------------------|---------|------------------------------|---|---------|
| <i>Asst. Engr.</i> | | | <i>Chief Insp.</i> | | |
| Lyddall, A. G. | E.-in-C.O. to S.W. Reg. | 1.6.45 | Venus, W. A. H. | L.T.R. to Tech. Costs Officer, Contracts Dept. | 25.9.44 |
| Jemmeson, A. E. | E.-in-C.O. to Scot. Reg. | 25.6.45 | Pollard, A. J. | E.-in-C.O. to L.T.R. | 22.6.45 |
| Glover, R. P. | S.W. Reg. to E.-in-C.O. | 1.7.45 | <i>Insp.</i> | | |
| Wells, H. G. | L.T.R. to E.-in-C.O. | 1.8.45 | Willoughby, E. | E.-in-C.O. to Cable Test | 7.5.45 |
| <i>Chief Insp. with Allee.</i> | | | Fleming, J. M. | E.-in-C.O. to N.E. Reg. | 12.8.45 |
| Spiers, J. C. | N.E. Reg. to Mid. Reg. | 8.6.45 | <i>Draughtsman, Class I.</i> | | |
| | | | Bailey, C. | Scot. Reg. to H.C. Reg. | 13.8.45 |

Retirements

| Name | Region | Date | Name | Region | Date |
|--------------------------------------|--------------|---------|-------------------------------|--------------------|---------|
| <i>Exec. Engr.</i> | | | <i>Chief Insp.—continued.</i> | | |
| Campbell, P. J. | N. Ire. Reg. | 2.5.45 | Croughton, G. F. | Test Sect., London | 22.8.45 |
| Vause, A. H. | L.T.R. | 31.7.45 | Penny, S. A. D. | L.T.R. | 31.8.45 |
| <i>Asst. Engr.</i> | | | <i>Insp.</i> | | |
| Mabey, H. | E.-in-C.O. | 30.6.45 | Ogburn, G. G. H. | H.C. Reg. | 4.2.45 |
| <i>Chief Insp. (with Allowance).</i> | | | Sugden, L. C. | N.E. Reg. | 25.5.45 |
| Morvan, A. R. | Mid. Reg. | 7.6.45 | Gregory, J. | L.T.R. | 2.6.45 |
| <i>Chief Insp.</i> | | | Davey, W. C. | L.T.R. | 11.6.45 |
| Parker, T. T. | H.C. Reg. | 31.3.45 | Bailey, A. P. | W. & B.C. Reg. | 28.7.45 |
| Mylius, W. A. J. | L.T.R. | 7.6.45 | Langford, F. J. | L.T.R. | 31.7.45 |
| Driver, E. G. | L.T.R. | 21.6.45 | Pond, G. M. | L.T.R. | 2.8.45 |
| Mann, F. | H.C. Reg. | 31.7.45 | Hogarth, R. N. | Scot. Reg. | 3.8.45 |
| | | | Lowrey, F. C. | L.T.R. | 4.8.45 |
| | | | Bagnall, G. W. | L.T.R. | 31.8.45 |

Resignations

| Name | Region | Date | Name | Region | Date |
|---------------|------------|---------|-------------------------|------------|---------|
| <i>Insp.</i> | | | <i>Insp.—continued.</i> | | |
| Rogers, F. E. | E.-in-C.O. | 10.8.45 | Carter, W. A. | E.-in-C.O. | 31.8.45 |

Deaths

| Name | Region | Date | Name | Region | Date |
|--------------------|---------------------------------|---------|--------------------|-----------|--------|
| <i>Chief Insp.</i> | | | <i>Insp.</i> | | |
| Heenan, J. P. | Killed while Prisoner of War | 14.4.45 | Riddle, H. | S.W. Reg. | 2.7.45 |
| | | | Thompson, W. H. S. | L.T.R. | 4.8.45 |

Clerical Grades—Promotion

| Name | Region | Date | Name | Region | Date |
|------------------------------------|------------|--------|------|--------|------|
| <i>Prin. Clerk to Staff Contr.</i> | | | | | |
| Ford, F. C. | E.-in-C.O. | 9.7.45 | | | |

Junior Section Notes

Aberdeen Centre

The Annual General Meeting was held on Thursday, May 24th, but the attendance was rather disappointing. At the conclusion of the financial statement the election of office bearers was proceeded with and resulted as follows:—

Chairman : Mr. D. S. C. Buchan.

Vice-Chairman : Mr. W. J. Cowie.

Hon. Secretary and Treasurer : Mr. S. D. F. Buchan.

Librarian : Mr. W. B. Davidson.

Committee : Messrs. D. F. M. Peters, N. Johnston, J. L. McLachlan, J. R. Tulloch, J. P. McGregor, J. Yule, C. L. Bannerman and J. A. W. Mann.

Auditors : Mr. C. P. Milne and Mr. F. L. Dignan.
S. D. F. B.

Brighton Centre

A General Meeting was held at Brighton on June 13th with the object of reforming the Local Centre, the activities of which had been suspended with the outbreak of hostilities in 1939. As a result of this meeting, which was very well attended, the following Officers were elected:—

Chairman : K. W. Chandler.

Treasurer : F. G. Anderson.

Secretary : G. J. Pearce.

A Committee was also elected and the gratifying result of their keenness is a membership of approximately one hundred to date.

The programme for the first half of the Winter Session has been arranged in the following manner:—

October 3rd.—“Traffic Problems,” G. Calcutt.

November 7th.—“U.G. Maintenance,” H. E. J. Huggins.

December 5th.—“Automatics—Past, Present and Future,” E. J. T. Hitchen. G. J. P.

Dundee Centre

With the approach of normal conditions and the welcome return of our serving members the Dundee Centre look forward to a happy and successful session during 1945-46.

An interesting programme has been arranged:

September.—“House Exchange System,” Mr. N. Chalmers.

October.—“Power,” Mr. J. M. Milne.

November.—“Amplification,” Mr. D. E. Kinnear.

December.—Film Show. D. A. B.

Sheffield Centre

The Sheffield Junior Section of the I.P.O.E.E. was revived on January 24th, 1945, and now has a membership of over 70.

The following programme has been arranged for the first half of the 1945/46 session:—

September 7th.—M.O.I. Film Show.

September 21st.—“V.F. Telegraphy,” H. S. Beddoes.

October 5th.—“P.M.B.X.1.A.,” F. Sellars.

October 19th.—“House Exchange System,” N. J. R. Hocker.

November 2nd.—Film Show.

November 16th.—“Photography,” W. C. Boston.

December 7th.—“Outline of Carrier Telephony,” G. E. Richardson.

December 21st.—Pie Supper and Social Evening.

T.O.R.

BOARD OF EDITORS

A. J. GILL, B.Sc., M.I.E.E., F.I.R.E., Chairman.

F. E. NANCARROW, O.B.E., A.R.C.Sc., M.I.E.E.

P. B. FROST, B.Sc., M.I.E.E.

A. H. MUMFORD, B.Sc.(ENG.), M.I.E.E.

C. W. BROWN, A.M.I.E.E.

G. H. S. COOPER.

H. LEIGH, B.Sc.(ENG.), A.M.I.E.E., Acting Managing Editor.

G. E. STYLES, A.M.I.E.E., Acting Assistant Editor.

A. J. BAKER, Secretary-Treasurer.

Copyright

The entire contents of this JOURNAL are covered by general copyright, and special permission is necessary for reprinting long extracts, but Editors are welcome to use not more than one-third of any article, provided credit is given at the beginning or end thus: “From the *Post Office Electrical Engineers' Journal*.”

The Board of Editors is not responsible for the statements made or the opinions expressed in any of the articles in this JOURNAL, unless such statement is made specifically by the Board.

Communications

All Communications should be addressed to the Managing Editor, *P.O.E.E. Journal*, Engineer-in-Chief's Office, Alder House, Aldersgate Street, London, E.C.1. Telephone: HEADquarters 1234. Remittances should be made payable to “*The P.O.E.E. Journal*” and should be crossed “& Co.”

Binding Cases

Cases for binding are available, and may be obtained from the Local Agents for 1s. 9d. Subscribers can have their copies of Volumes bound, at a cost of 3s., by sending the complete set of parts to the Local Agents or to the *P.O.E.E. Journal*, Engineer-in-Chief's Office, Alder House, Aldersgate Street, London, E.C.1. Orders for binding for Vols. 1-19 should indicate whether the original binding case with black lettering, or the later pattern with gold, is required. Cases with gold lettering are the only type stocked from Vol. 20 onwards.

Back Numbers

The price of the JOURNAL, which is published quarterly, is 1s. (1s. 3d. post free) per copy, or 5s. per annum post free. Back numbers can be supplied, subject to availability of stocks, at 1s. each (1s. 3d. post free). Orders for back numbers may be sent to the Local Agents or to the Publishers.

Advertisements

All communications relating to space reservations should be addressed to the Advertisement Editor, *P.O.E.E. Journal*, Alder House, Aldersgate Street, London, E.C.1. Communications regarding advertisement copy, proofs, etc., should be addressed to the Publishers, Messrs. Birch & Whittington (Prop. Dorling & Co. [Epsom], Ltd.), 49 Upper High Street, Epsom, Surrey.

NOTE.—The fact that goods made of raw material in short supply owing to war conditions are advertised in this Journal should not be taken as an indication that they are necessarily available for export.

50-range Model 7
Universal AvoMeter

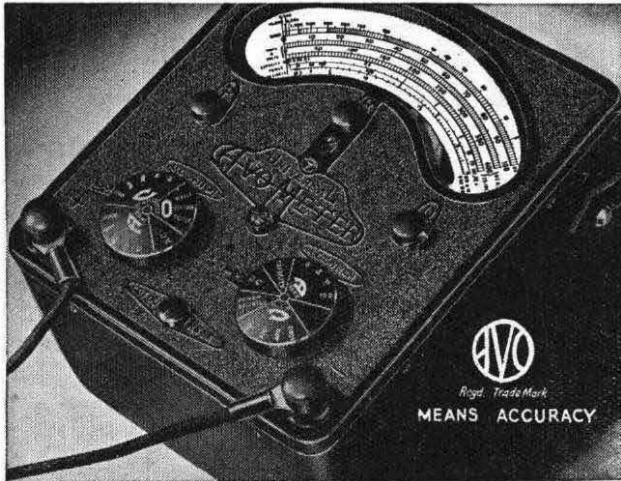

'AVO'
Regd. Trade Mark

Meters that Matter

THE world-wide use of "AVO" Instruments is striking testimony to their outstanding versatility, precision and reliability. In every sphere of electrical test work, they are appreciated for their dependable accuracy, which is often used as a standard by which other instruments are judged.

Sole Proprietors and Manufacturers

THE AUTOMATIC COIL WINDER & ELECTRICAL EQUIPMENT Co. Ltd
Winder House, Douglas Street, London, S.W.1 Phone: VICTORIA 3404-8

These dials will interest you:—

DIALS & DRIVES: TYPES D-115-A & D-206-A.

TYPE D-115-A employs a 20:1 worm reduction gear providing a right-angle drive for two components. TYPE D-206-A employs a 20:1 spur reduction gear providing a single in-line drive.

OUTSTANDING FEATURES:—

- High reading and setting accuracy by means of a dial embodying an adding mechanism—effective scale length over 12 ft. with 500 divisions.
- Gears spring-loaded to reduce backlash.
- Rugged die-cast construction and substantial bearings for long and continuous service.
- Shafts: $\frac{1}{4}$ in. diameter and $\frac{9}{16}$ in. projection.
- Finish: gunmetal with engraving filled white.
- Weight: 2½ lb.

Dial manufactured under licence from the Sperry Gyroscope Co. Ltd.
Pat. No. 419002.

Full description in

Bulletins I-532-B and B-556-A

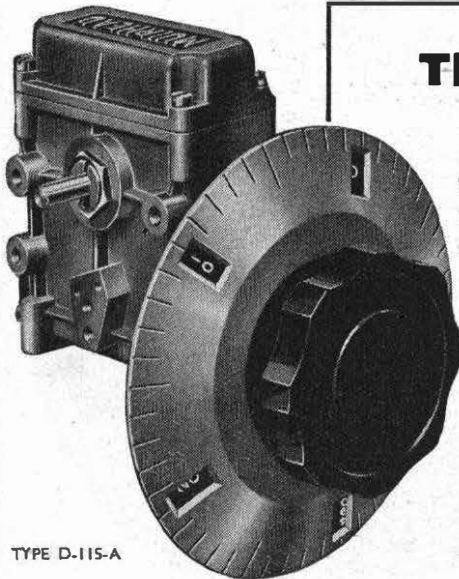

TYPE D-115-A

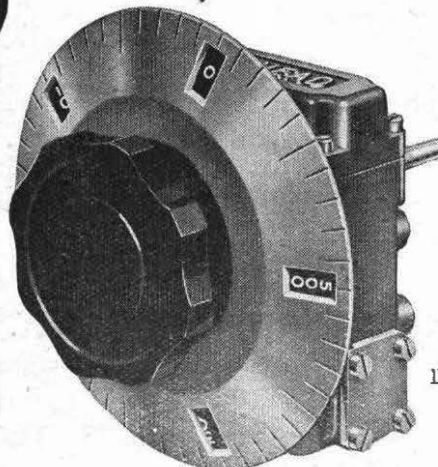

TYPE D-206-A

MUIRHEAD

MUIRHEAD & COMPANY, LTD., ELMERS END
BECKENHAM, KENT BECKENHAM 0041-2

FOR OVER 60 YEARS DESIGNERS AND MAKERS OF PRECISION INSTRUMENTS.

© 1941 G.F.

Clip-on

FOR EASY CURRENT MEASUREMENTS

in Busbars, Fuses and Cables up to 2 1/8" diam.

- DUAL RANGE WITH SELECTOR SWITCH
- FULLY INSULATED CORE AND HANDLE

FERRANTI

DUAL RANGE

Clip-on AMMETER



QUICK CHANGE TO NEW RANGE

RANGES

- 0—10—50 Amps.
- 0—20—100 Amps.
- 0—50—250 Amps.
- 0—100—500 Amps.
- 0—200—1000 Amps.

FI 60a

FERRANTI LIMITED, Hollinwood, Lancs.

London Office : Kern House, Kingsway, W.C.2

TURNER DIFFERENTIAL MILLIAMMETERS

G.P.O. No. 17 & No. 18

Meet the most exacting demands for balancing currents in multiplex telegraph circuits.

— A quality product of outstanding merit —

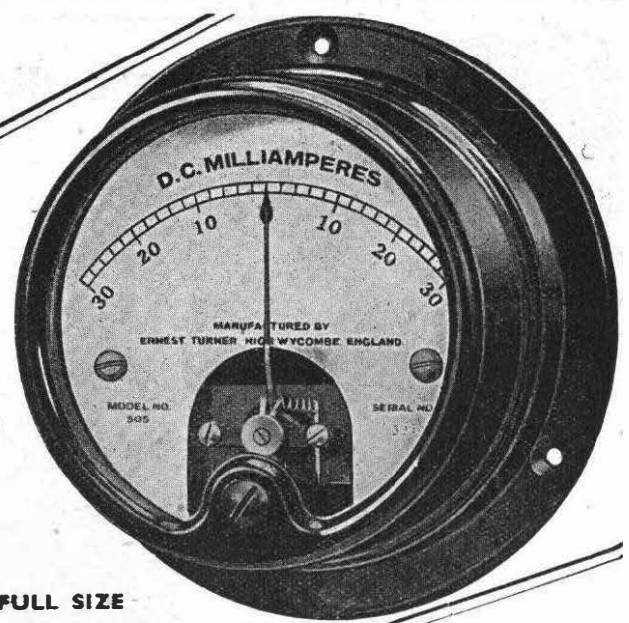

FULL SIZE

Also manufacturers of G.P.O. Detector No. 4, and a comprehensive line of instruments for precision electrical measurements.

ERNEST TURNER ELECTRICAL INSTRUMENTS, Ltd.

CHILTERN WORKS,
49-73 TOTTERIDGE AVENUE,
HIGH WYCOMBE,
BUCKS, ENGLAND

Telephone : High Wycombe 1301, 1302.
Telegrams : Gorgyous High Wycombe.

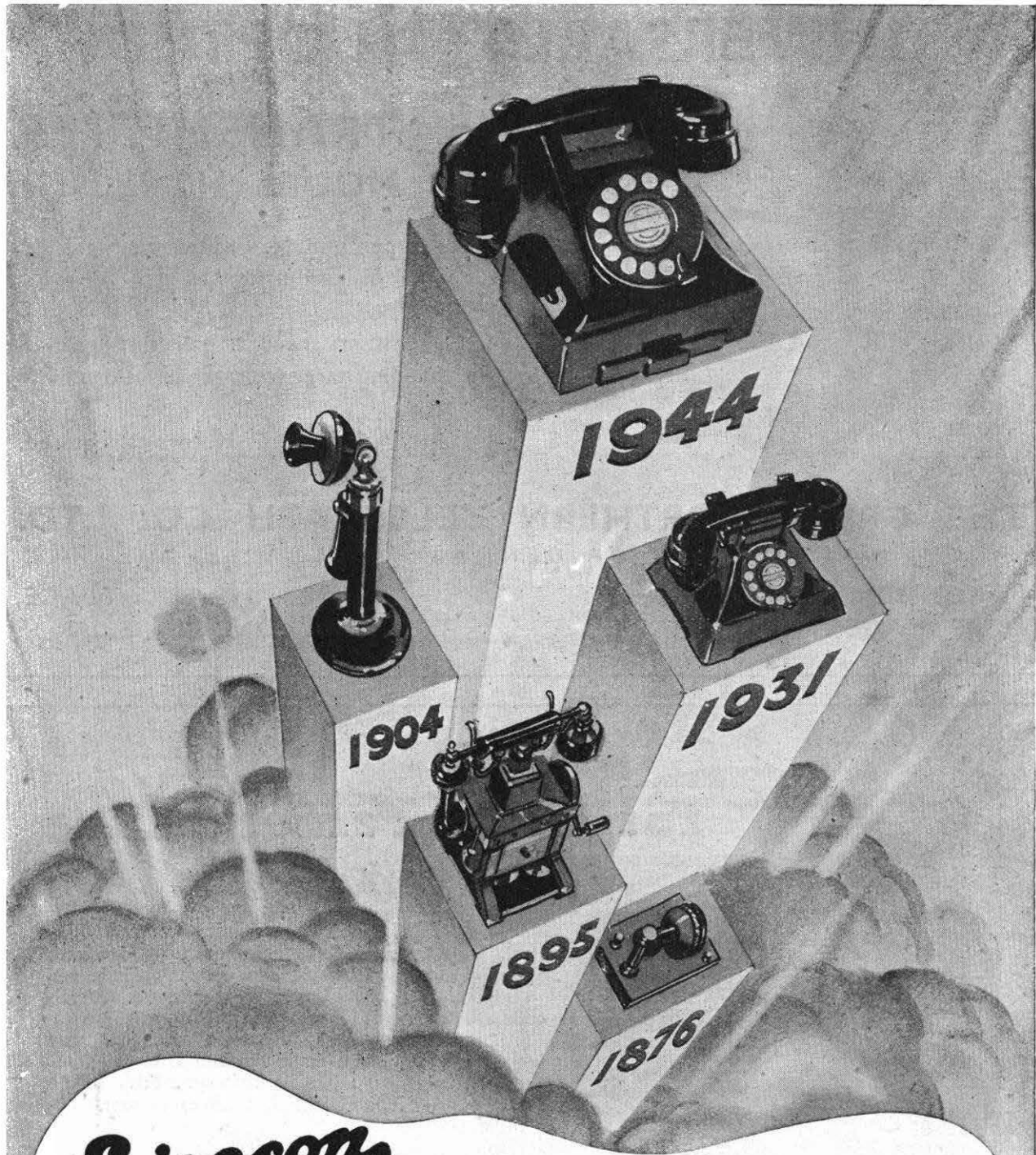

Ericsson

66 years of steady progress in telephony and its applications sees Ericssons in their extensive plant to-day utilising Modern Plastics for the improvement of telephone design and efficiency. Ericssons have unrivalled experience in

the production of telephone equipment required to function under tropical and similar extreme conditions—taking full advantage of the application of Plastics in this connection. Enquiries welcomed.

ERICSSON TELEPHONES LTD., Head Office: 56, Kingsway, London, W.C.2. Tel.: -HOL. 6936. Works Beeston, Notts.

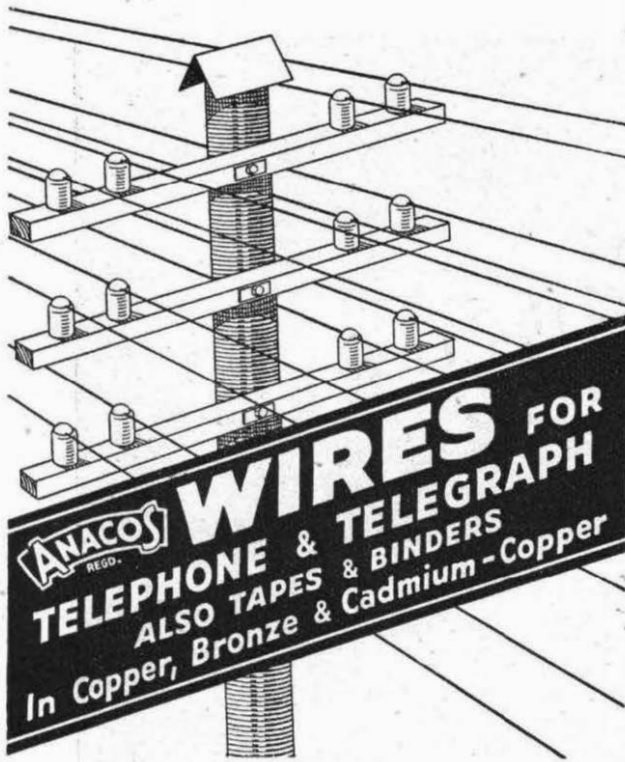

FREDERICK SMITH & CO. LTD. (Incorporated in The London Electric Wire Company and Smiths, Limited.)
ANACONDA WORKS, SALFORD, 3, LANCs.
 Telephone : BLACKFRIARS 8701 (9 lines)
 Telegrams : "ANACONDA" MANCHESTER

H. T. A. LIMITED

Formerly Hall Telephone Accessories (1928) Limited.

Contractors to H.M. Post Office, Admiralty, M.A.P., M.O.S., and Dominion and Foreign Administrations.

Precision Engineers & Instrument Makers

Manufacturers of Prepayment Telephone Multi-Coin Collectors, Gas Leak Indicators, Automatic Stamp Selling and Ticket Selling Machines, Automatic Slot Machines and Fire Alarm Apparatus.

Enquiries Invited.

Registered Office and Works :—

**DUDDEN HILL LANE, WILLESDEN,
LONDON, N.W.10**

Tel. WILLESDEN 5141, etc. Also DOWLAIS, GLAM.

Specially designed for operation under
ADVERSE ATMOSPHERIC CONDITIONS

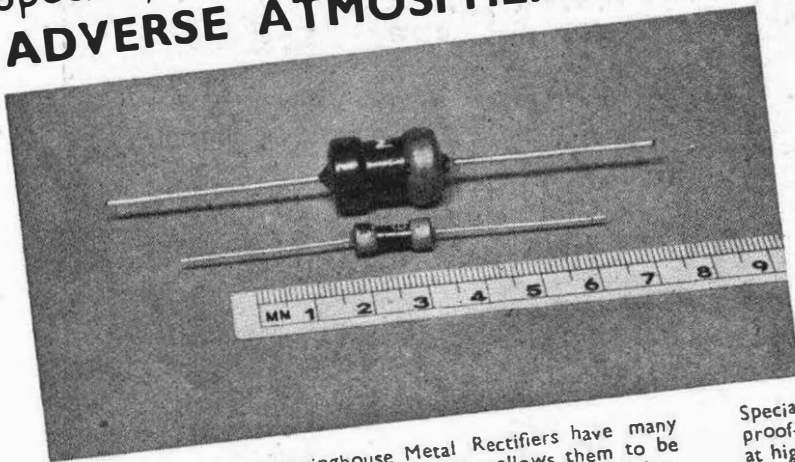

These new miniature Westinghouse Metal Rectifiers have many advantages over the older types. Their size allows them to be suspended in the wiring of the apparatus, or they may be fixed on a "group board." End wires are provided for soldered connections.

KH (Miniature H type) unit.
Available with up to six series elements.

Miniature W or WX Westector.
Available with up to six series elements.

Specially sealed for use in damp atmospheres—"fungus" proof—and can be treated to provide stable characteristics at high temperatures.
We shall be pleased to send you full details.

WESTINGHOUSE
METAL RECTIFIERS
 WESTINGHOUSE BRAKE & SIGNAL CO. LTD.,
 Pew Hill House, Chippenham, Wilts.

LINK THE WORLD'S RESOURCES - - -

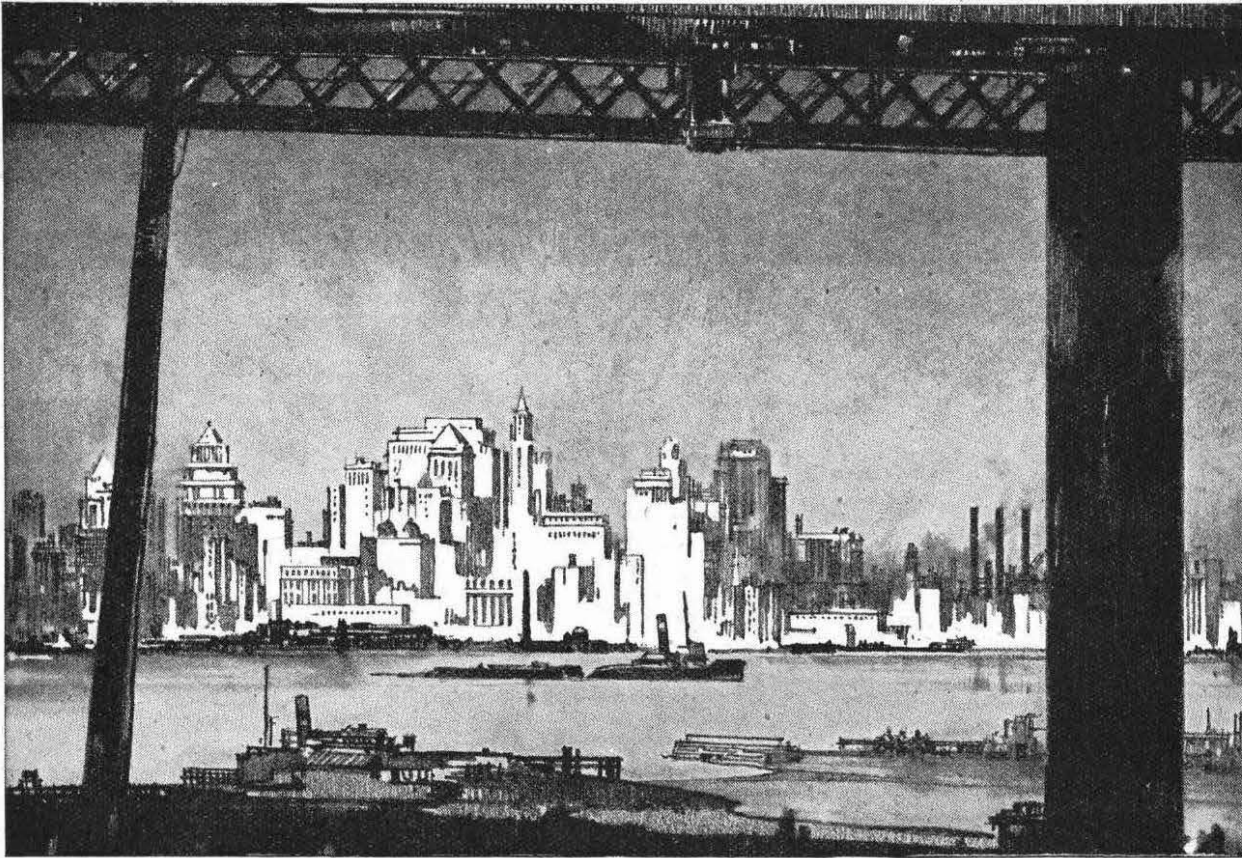

IN THE METROPOLIS

Nature has provided a wealth of raw materials but man himself must prize them from the grip of the earth, transport, process and finally fashion them into articles to be utilised by the peoples of the world. Where this activity is most concentrated and reaches its highest pitch a great Metropolis springs up, having in addition to its own internal affairs, the function of control and co-ordination of widespread outlying areas. Efficient telecommunications are an essential need . . . but many operating problems arise; the vastness of subscriber-totals, the multiplicity of exchanges, the high calling-rate, the 'busy-hour' periods and the constant demand for long-distance and special service calls. The Strowger Automatic Telephone Director-System was specially evolved to solve these operating problems and has for many years been performing efficiently and economically in London and many other of the World's largest cities.

with **STROWGER**
TELECOMMUNICATIONS

AUTOMATIC TELEPHONE & ELECTRIC CO. LTD.
NORFOLK HOUSE, NORFOLK ST., LONDON, W.C.2. TEMple Bar 9262
STROWGER WORKS, LIVERPOOL, 7, ENGLAND

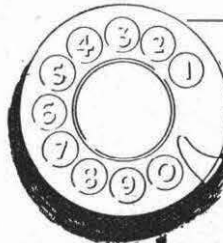

The Strowger Selector

- has a wiper carriage of light construction, thus reducing its inertia and ensuring maximum speed.
- has self-aligning contact wipers which ensure equality of pressure on the upper and lower bank contacts.
- has spring sets with twin contacts on wide centres giving maximum visibility and designed to eliminate contact bounce.
- has the same horizontal mounting centres, and front and rear projection as for relay sets, enabling composite racks of the utmost compactness to be used.
- has the vertical and rotary magnet assemblies fitted with toggle type interrupters which ensure more positive 'make' & 'break' action than could be obtained with conventional type interrupters.





FOR ALL
TELE-COMMUNICATIONS
& LIGHT-CURRENT SIGNALLING REQUIREMENTS

| | |
|---|--|
| TELEPHONE EQUIPMENT | Public Telephone Exchange Systems, Automatic and Manual. Private Telephone Systems, Auto, C.B. Manual and Magneto. Railway Telephone Systems, Code and Selective Ringing. Mining Telephone Systems. Telephone Instruments, Telephone Repeaters, etc. |
| CARRIER EQUIPMENT | Aerial Line Carrier Telephone Equipment, 1 to 12-Channel. Cable Circuit Carrier Telephone Equipment, 1 to 24-Channel. Voice-Frequency and Carrier Telegraph Equipment, Multi-Channel. Power Line Carrier Equipment for Telephony, Protection, Supervisory Control and Metering. |
| RADIO EQUIPMENT | Police Radio, Fixed and Mobile Working. Point to Point Links. Railway Communication Networks. Aircraft Radio. Aircraft to Ground Communication. Radio Remote Control. Emergency Communication Systems. Communication Receivers. Broadcast Radio Receivers |
| SOUND REPRODUCTION EQUIPMENT | Sound Reproduction Equipment for Factory Control and Staff Location. Railway Station Announcing Systems. Sound Reinforcement Equipment. |
| LIGHT-CURRENT SIGNALLING EQUIPMENT | Supervisory Control Equipment for Power Distribution Control, Industrial Process Control, etc. Ripple Control Equipment for Signalling over Power Networks. Railway Train Describers. Automatic Equipment for Control, Indication, Calculation, Testing, etc. |

THE GENERAL ELECTRIC CO. LTD.
OF ENGLAND
Telephone and Radio Works — Coventry, England.
Head Office — Magnet House, Kingsway, London, W.C.2.

WAVEMETERS

OSCILLATORS

CONDENSERS

INDUCTANCES

RESISTANCES

Electrical Standards for Research and Industry

Testing and Measuring Apparatus for Communication Engineering

H. W. SULLIVAN
— LIMITED —

London, S.E.15

Tel. : New Cross 3225 (P.B.X.)

BRIDGES — Capacitance
Inductance
Resistance

ALL TYPES — ALL FREQUENCIES — ALL ACCURACIES

ELLIOTT

MEASURING

Instruments for Telecommunications Equipment

MOVING COIL, RECTIFIER AND THERMAL TYPES

The instrument illustrated is a D.C. Differential Milliammeter. We also make a four-range, rectifier-operated Milliammeter or Millivoltmeter for A.C. measurements at power and audio frequencies and Telegraphic Transmitting, Receiving and Testing Equipment.

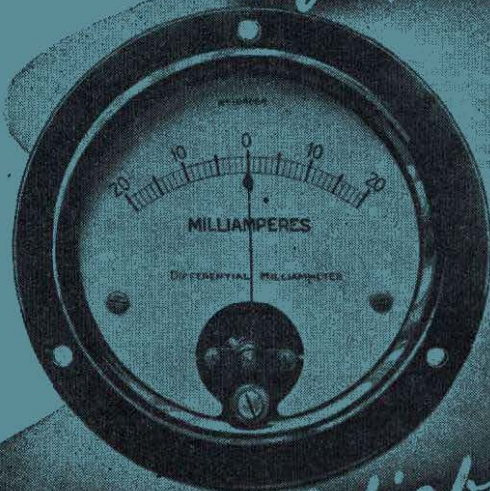

Accurate & Reliable

ELLIOTT BROTHERS (LONDON) LTD. CENTURY WORKS, LEWISHAM, S.E.13

MAINTAINING EFFICIENCY

THE HIGH STANDARD OF EFFICIENCY
OF PIRELLI - GENERAL TELEPHONE
CABLES IS MAINTAINED BY THE
CONTINUOUS RESEARCH WORK OF
AN EXPERIENCED TECHNICAL STAFF.

TELEPHONE:
SOUTHAMPTON
2141 (5 lines).

PIRELLI-GENERAL
CABLE WORKS, Ltd., SOUTHAMPTON.

TELEGRAMS
"PIREKAYBEL"
SOUTHAMPTON.

60/40
45/55

WHAT'S THE DIFFERENCE ANYWAY?

Government reduction of tin content of alloys often means the increase of soldering temperatures if satisfactory soldering processes are to be achieved. But what increases are necessary? How will the components be affected by increased heat? These and other technical queries are answered in "Technical Notes on Soldering," issued by the manufacturers of Ersin Multicore the A.I.D. and G.P.O. approved three core Solder Wire. Firms engaged on government contracts are invited to write for a copy of this reference sheet and samples of Ersin Multicore Solder Wire.



ERSIN MULTICORE

THE SOLDER WIRE WITH 3-CORES OF NON-CORROSIVE ERSIN FLUX

MULTICORE SOLDERS LIMITED, BUSH HOUSE, W.C.2. 'Phone Temp.Bar 5583/4