

THE POST OFFICE ELECTRICAL ENGINEERS' JOURNAL

VOL. 38

JULY, 1945

PART 2

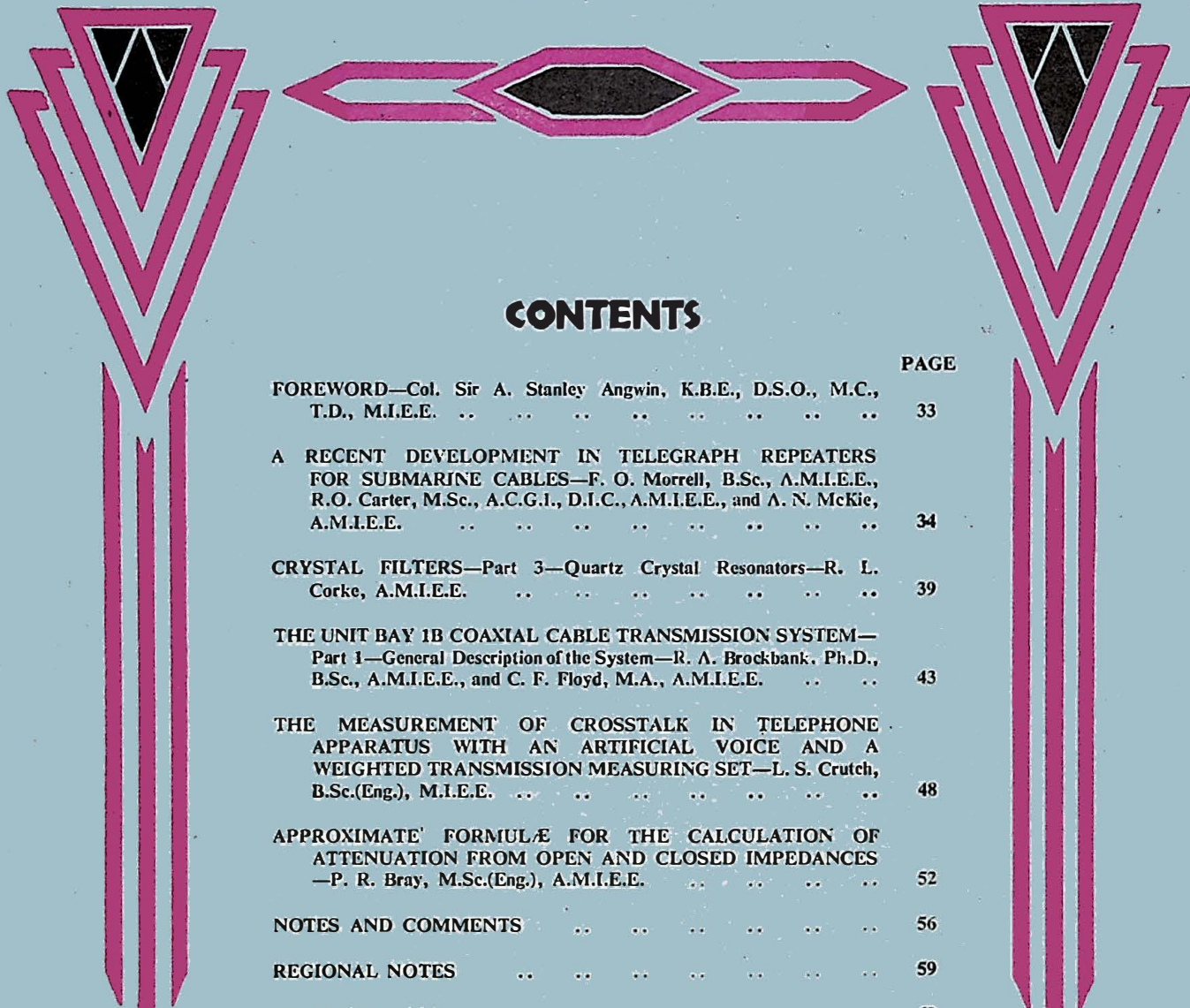

CONTENTS

	PAGE
FOREWORD—Col. Sir A. Stanley Angwin, K.B.E., D.S.O., M.C., T.D., M.I.E.E.	33
A RECENT DEVELOPMENT IN TELEGRAPH REPEATERS FOR SUBMARINE CABLES—F. O. Morrell, B.Sc., A.M.I.E.E., R.O. Carter, M.Sc., A.C.G.I., D.I.C., A.M.I.E.E., and A. N. McKie, A.M.I.E.E.	34
CRYSTAL FILTERS—Part 3—Quartz Crystal Resonators—R. L. Corke, A.M.I.E.E.	39
THE UNIT BAY 1B COAXIAL CABLE TRANSMISSION SYSTEM—Part 1—General Description of the System—R. A. Brockbank, Ph.D., B.Sc., A.M.I.E.E., and C. F. Floyd, M.A., A.M.I.E.E.	43
THE MEASUREMENT OF CROSSTALK IN TELEPHONE APPARATUS WITH AN ARTIFICIAL VOICE AND A WEIGHTED TRANSMISSION MEASURING SET—L. S. Crutch, B.Sc.(Eng.), M.I.E.E.	48
APPROXIMATE FORMULÆ FOR THE CALCULATION OF ATTENUATION FROM OPEN AND CLOSED IMPEDANCES—P. R. Bray, M.Sc.(Eng.), A.M.I.E.E.	52
NOTES AND COMMENTS	56
REGIONAL NOTES	59
STAFF CHANGES	62
JUNIOR SECTION NOTES	64

Price 1/- net

THE INSTITUTION OF POST OFFICE ELECTRICAL ENGINEERS



GE CALLOY

RADIO CORES

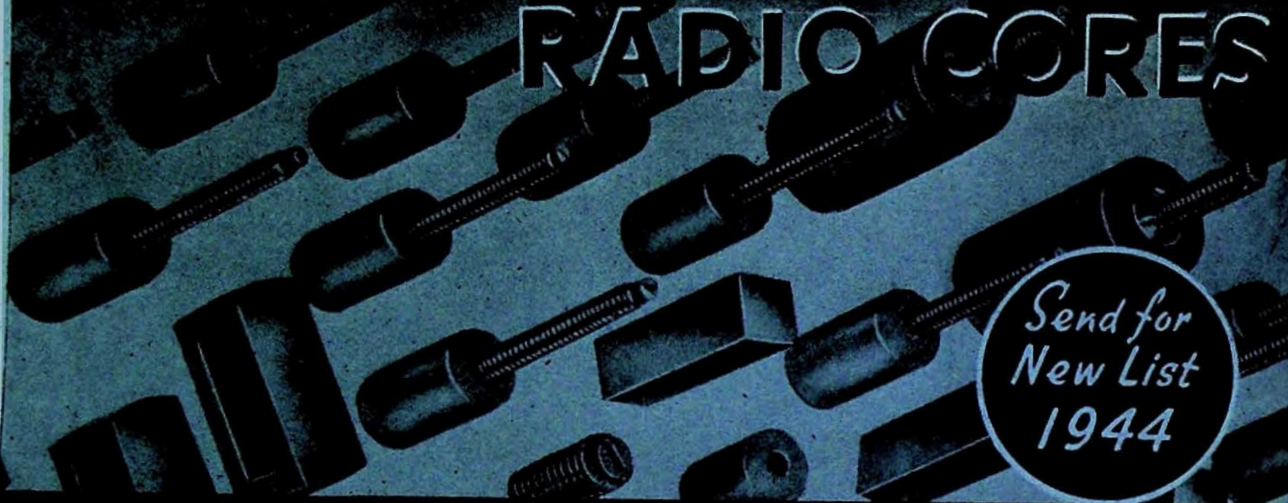

Send for
New List
1944

SALFORD ELECTRICAL INSTRUMENTS LTD.

PEEL WORKS, SALFORD, 3. Telephones : BLAckfriars 6688 (6 lines). Telegrams and Cables : "Sparkless, Manchester"
PROPRIETORS: THE GENERAL ELECTRIC Co. Ltd., OF ENGLAND

*For large scale
Electrical
Purposes*



It is noteworthy where Tudor accumulators are to be found fulfilling the most important duties: over 500 British Power Stations installed Tudor. Many Tudor installations rank among the largest in the land and have an enviable reputation for long-lived reliability. No matter whether they were installed only yesterday, or over thirty

years ago—as many of them were—they are to-day functioning with consistent efficiency.

SAFETYLYTE (Patent No. 313248) is the Tudor Emergency Lighting System, which is automatic and instantaneous in operation. It is installed in thousands of schools, hospitals, factories and other large buildings.



TUDOR ACCUMULATORS

THE TUDOR ACCUMULATOR CO. LTD
50 GROSVENOR GARDENS, LONDON, S.W.1

THE POST OFFICE

ELECTRICAL ENGINEERS' JOURNAL

Vol. XXXVIII

July, 1945

Part 2

FOREWORD BY

COL. SIR A. STANLEY ANGWIN, K.B.E., D.S.O., M.C., T.D., M.I.E.E.

Engineer-in-Chief to the British Post Office.

NOW that hostilities in Europe are over it is an appropriate time to put on record in this journal of the Post Office Electrical Engineer, some of the work performed during the war years by all members of the engineering staff of the Post Office.

Of a peace-time staff of approximately 50,000, over 8,000 were mobilised on the outbreak of war, and a further 8,000 have since been released for service with the Armed Forces, mostly as technical staff in the Royal Corps of Signals or for flying duties with the Royal Air Force. Over 300 men have also been released for service in a civilian capacity with the Service and Supply Departments, etc. 620 members of the Engineering Department made the supreme sacrifice.

At home, a large proportion of the energies of the Department has been devoted to providing and maintaining service for the numerous naval, military and air force establishments in this country and for key industries. This involved the provision of a private wire network, mostly between sparsely telephoned localities, greater in extent than the pre-war trunk network and the extension of certain of the public services. All lines and equipment have had to be maintained in a high degree of efficiency with a diluted staff and in face of sustained enemy aerial bombardment. At sea, too, our routes to allied countries have had to be maintained in service and new routes provided. High praise is due to the staffs of our cable ships on whom this task fell and who suffered grievous casualties in carrying out the work.

A further load which has been willingly shouldered by the Engineering Department has been assistance to the Fighting Services in the design and production of all types of telecommunications equipment. The Post Office Research Station and the Post Office factories have been almost entirely employed on work of this nature, and the Post Office also undertook the purchasing of vast quantities of signals equipment on behalf of the three Fighting Services. The Engineering Department co-operated whole-heartedly in the work of the various inter-service technical and production committees and was responsible for the control of the production of most telecommunications equipment and cable.

In the months to come it may be possible to lift the curtain gradually on these war-time activities and to describe in this Journal some of the enormous tasks that were undertaken. In the meanwhile, members of the Engineering Department may rest content in the knowledge that the vital tasks allotted to them have been well and truly done.

In giving this brief summary of Post Office engineering war work, I should like to express my confidence that the same spirit of comradeship and co-operation which has contributed so largely to the success of our war-time tasks will enable the goal now confronting us of bringing the Japanese war to an early conclusion, of effacing the ravages of war in this country and of reharnessing our energies to the peace-time services to be speedily and smoothly attained.

A. S. Angwin

A Recent Development in Telegraph Repeaters for Submarine Cables

F. O. MORRELL, B.Sc., A.M.I.E.E.,
 R. O. CARTER,
 M.Sc., A.C.G.I., D.I.C., A.M.I.E.E., &
 A. N. MCKIE, A.M.I.E.E.

U.D.C. 621.394.641

This article describes a modern type of telegraph repeater designed for Wheatstone or teleprinter operation on submarine cables. The repeater comprises an attenuation equaliser followed by a push-pull amplifier working on a modified impulse basis, with a special circuit to restore the D.C. and low frequency components of the signal. Duplexing facilities are provided.

Introduction.

Between 1930 and 1940 the telegraph system of Great Britain underwent a striking change; before 1930 the system which had grown from the earliest days of telegraphy comprised a wide assortment of all types of equipment, whereas after that date a simple, uniform scheme consisting of multi-channel voice-frequency circuits and direct current extensions covered practically the whole country. The D.C. extensions were of the simplest kind, worked on a two-line simplex double-current basis, with a few types of standard terminations to cover the whole range of line characteristics. For the most part the lines were short, and although the longer circuits were terminated with a line relay, and could therefore be considered as repeated, the standard duplex repeater previously used had practically ceased to exist in the Post Office network. The result was that when in the early part of the war a need arose for a duplex telegraph repeater to be used for Wheatstone or teleprinter operation on submarine cables, it became necessary to design and build apparatus suitable to be maintained by staff not familiar with the older types of telegraph equipment. In particular, the standard submarine cable repeaters were considered quite unsuited to present-day conditions in this country. The equipment was to be housed in multi-channel voice-frequency telegraph stations, which made it desirable to use rack-mounted apparatus and components with which the present staff would be familiar.

In consequence the equipment differed entirely, as regards both the circuit design and layout from that used hitherto for such circuits, and it is considered to be of general interest to describe it here.

General Design Principles.

The cables over which these repeaters were expected to operate were not long enough to make the normal methods of telegraphy technically very difficult, and consideration was given to the relative merits of Gulstad circuits and valve amplifiers used in conjunction with the commoner items of telegraph apparatus. The famous Gulstad circuit has, indeed, much to recommend it, but it has one serious disadvantage. It is a species of locked relaxation oscillator, with the result that the frequency response is poor, and for a given set of component values, benefit is obtained over a narrow band of frequencies, or range of speeds, only. Furthermore, the optimum speed of working is dependent on the characteristics of the circuit elements—e.g. on relay adjustments and other factors likely to vary from day to day.

One of the first cables on which the apparatus was to be used was known to be subject to severe earth currents, the effects of which it was proposed to avoid by the use of series condensers or a transformer between the cable and the receiving apparatus. Under these conditions a Gulstad circuit cannot be fully effective. It was therefore decided to use a push-pull amplifier preceded by a transformer which served the double purpose of eliminating the effects of earth current and providing a voltage step-up to the grids of the valves.

The use of a transformer is commonly referred to as impulse working. It is a generally agreed principle in telegraph apparatus design that to avoid characteristic distortion the disturbance introduced into a circuit by a changeover from Mark to Space or vice versa shall have been substantially completed before the next changeover takes place. In a changeover from Mark to Space takes place in a circuit consisting of a transformer inserted between the transmitting tongue and the receiving relay there follows in the secondary circuit—which normally includes the receiving relay—an impulse whose duration is a function of the time-constant of the circuit, i.e. of the L/R ratio. If this time-constant is considerably shorter than the unit element, the impulse will have died away before the next changeover occurs, and theoretically transmission can be distortionless. If, on the other hand, the time constant is long, there will be interference between the disturbances created by successive changeovers and distortion will result. It would appear, therefore that in all impulse circuits component values should be chosen so that the impulse has substantially died

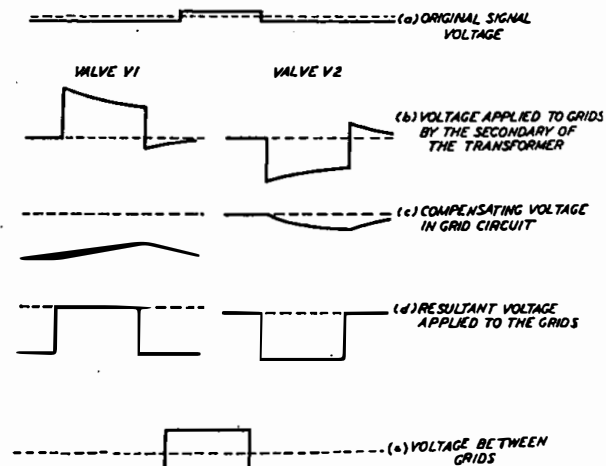

FIG. 1.—RESTORATION OF THE D.C. VOLTAGE.

away in the period of the unit element. Unfortunately the relay is then without appreciable holding current, and is subject to false operation by interference due to crosstalk and imperfect balance in duplex circuits.

The alternative scheme of a long time-constant has the advantage that if it is sufficiently long a holding current is in fact available over a period of several elements, but the adverse effects of the long transient must be avoided by introducing, after the relay has operated, an equal and opposite disturbance to balance out the tail of the first. This is equivalent to the restoration of the D.C. and low frequency components cut out by the transformers. The total effect is shown in Fig. 1, which illustrates by way of example the transmission of an isolated dot signal.

- (a) Shows the original signal.
- (b) Shows the signal in the transformer secondary.
- (c) Shows the compensating voltage.
- (d) The sum of (b) and (c), which is in effect the same as (a).

It will be noted that in the ideal case the wave-forms of both the originating and compensating disturbances are exponential in shape and can be reproduced with great accuracy by the use of suitable reactors and resistors.

In this repeater a long time-constant has been employed. It requires a transformer having a uniform insertion loss from the highest relevant signal frequencies down to about 1 c/s.

The complete repeater can conveniently be divided into three parts: (1) signal shaping network; (2) amplifier and D.C. restoring circuit, and (3) duplexing facilities.

Signal Shaping Network.

If the circuit is to have no characteristic distortion, the attenuation and phase must be approximately equalised at least up to a frequency equal to the fundamental frequency of reversals at the highest

Constant impedance equalisers of the type familiar in telephone line practice are used, the basic network being shown in Fig. 2. In this network, provided Z_1 and Z_2 are inverse, such that $Z_1 Z_2 = R_0^2$, the input impedance of the network is equal to R_0 , a constant pure resistance, at all frequencies.

Since the characteristic impedance of an unloaded cable varies rapidly with frequency, and has a large negative angle, no particular advantage is gained by the use of constant impedance equalisers as regards reflections. Their use does, however, simplify the design. The insertion loss-frequency characteristic of the cable is calculated for a pure resistance termination R at the receiving end. For simplex operation and for minimum loss, the value of R should be approximately equal to the modulus of the cable

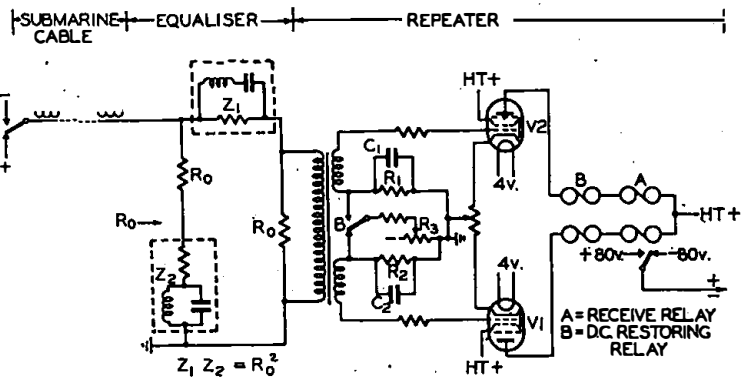

FIG. 2.—SUBMARINE TELEGRAPH CABLE REPEATER—BASIC CIRCUIT.

impedance at the highest frequency to which equalisation is to be carried out. If now a constant impedance equaliser is inserted having a design impedance R_0 equal to this terminating resistance R , the loss of the equaliser can be directly added, since the insertion loss of the cable will remain unaltered. This simplifies the work considerably, as owing to the fact that the cable is electrically short, and

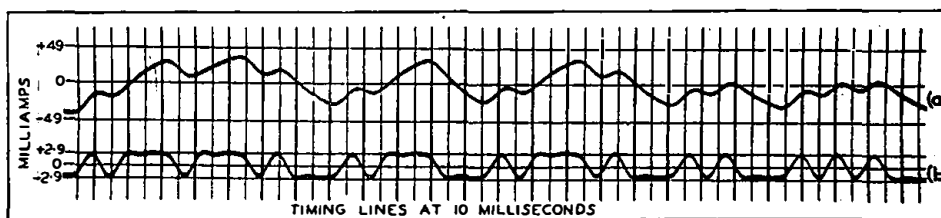

FIG. 3.—SIGNALS RECEIVED OVER ARTIFICIAL LINE REPRESENTING SUBMARINE TELEGRAPH CABLE—(A) BEFORE EQUALISATION. (B) AFTER EQUALISATION. TEST WORD: PARIS. (RESISTANCE, 1,550 OHMS. CAPACITANCE, 120 MICROFARADS. SPEED, 90 BAUDS.

signalling speed to be used. Preferably the equalisation should be carried to about 20 per cent. above this frequency. In the practical applications so far encountered, the attenuation equalisers have also equalised the phase with fair accuracy, and no special phase compensating networks have been necessary.

reflections at both ends are far from negligible, the calculation of insertion loss characteristics is laborious. Fig. 3 shows a typical example of the signal current received in a non-reactive resistor termination with and without the equaliser. The different scales of the two oscillograms should be noted.

Application of Duplex.

The particular type of constant impedance network used, i.e. the type in which the first arm is a shunt impedance, was chosen to facilitate duplex working. A balanced form of the network is used, as shown in Fig. 4. The transmitter is connected to the mid-point of the shunt inductor, the two halves of which

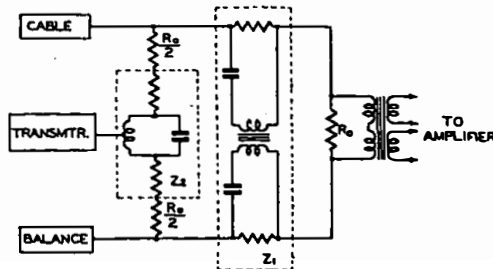

FIG. 4.—BALANCED EQUALISER FOR DUPLEX OPERATION.

replace the bridge arms of the traditional bridge duplex arrangement. As the mid-point is the centre point of the inductance coil of this shunt impedance, the coil is non-inductive for transmission and the only added impedance is therefore the resistance of half the shunt arm, which in practice, owing to the invariably high basic loss of the section, is very nearly equal to $R_0/2$. For duplex operation, R_0 , the design impedance of the equalisers will of course be twice that for simplex operation, due to its connection to line and balance in series.

The type of artificial line used for the duplex balance was suggested by J. W. Milnor in 1922. It is made up of a number of T sections with resistance elements in series and capacitance in shunt as shown in Fig. 5.

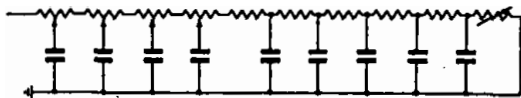

FIG. 5.—TYPICAL ARTIFICIAL LINE PROVIDING A DUPLEX BALANCE.

The majority of the sections of the balance can be fixed, but the first few must be variable to enable an accurate balance to be obtained. The variable sections simulate about ten miles, and the fixed sections about forty miles of cable each. A variable resistor terminates the network. The component values of the individual sections are derived from the cable splice list. For the cables so far provided with these balance networks, it has been possible to determine the ratios of the sections with reasonable accuracy and adjustments in the field have been confined to the variable sections and the terminating rheostat.

Amplifier and D.C. Restoring Circuit.

The basic circuit of the amplifier is shown in Fig. 2. It consists of an input transformer followed by two valves in push-pull, the normal relay receiving A, being in the anode circuits of the two valves. This

amplifier has a pass-band extending from approximately 1 c/s—100 c/s, which is considerably more than the highest signalling frequency.

The time-constant of the input circuit is of the order of half a second, and, therefore, a signal changeover in the primary winding of the input transformer produces an impulse in the secondary, i.e. the amplifier grid circuit, which dies away very gradually. To compensate for this die-away, an equal and opposite voltage is introduced into the grid circuit by the additional relay B in the valve anode circuits. This relay, having operated to the signal, applies a voltage to the appropriate grid circuit through resistor R_3 , and across C_1 , the voltage of which gradually rises to compensate for the gradual fall of potential across the secondary of the transformer. In the other grid circuit the potential across C_2 falls at very nearly the same rate as it rises across C_1 . The algebraic sum of the voltages across C_1 and C_2 is the required compensating voltage illustrated in Fig. 1(c).

The time-constants of the CR networks in the grid circuits can be made equal to that of the LR network consisting of the input transformer and the equaliser terminating resistor. At frequencies of one or two c/s. the impedance of the equaliser, which is in parallel with the terminating resistor, is so high that its effect on the time-constant is negligible.

The amplifier including the D.C. restoring circuit is a unit independent of the cable on which it is worked. The equaliser is designed to suit the cable with which it is associated, and experience has shown that this can be done accurately and without great difficulty. Across the resistor terminating the equaliser it is assumed that there exist substantially perfect signals. To set up the amplifier, the D.C. restoring circuit is first cut out, and the bias adjusted on high speed reversals. Continuously repeated signals, consisting of one element space followed by five elements mark are then applied to the amplifier and the D.C. restoring voltage adjusted for minimum distortion. No other adjustments are required.

Typical System.

Fig. 6 shows the bay layout and Fig. 7 the schematic diagram of the circuit of the terminal equipment for a cable of total resistance 1,550 Ω and total capacitance 102 μF (i.e. a value of capacitance \times resistance, or "KR," of 158,000 $\Omega\text{-}\mu\text{F}$). The equipment is mounted on standard 19 in. panels on a single 6 ft. 6 in. bay. The equipment of conventional design which it replaced was table mounted and occupied an area of 5 ft. \times 2 ft.

The cable is operated with a receiving termination of 120 Ω . The calculated insertion loss of the cable with this termination with and without equalisation, is shown in Fig. 8. The oscillograms of Fig. 3 also refer to this cable. The receiving amplifier, equaliser and duplex balance are constructed as separate units with the monitoring circuits brought out to a jack field on a control panel. A single meter on this panel provides facilities for checking the neutrality of the signals at essential points in the circuit. Communication between the repeater and

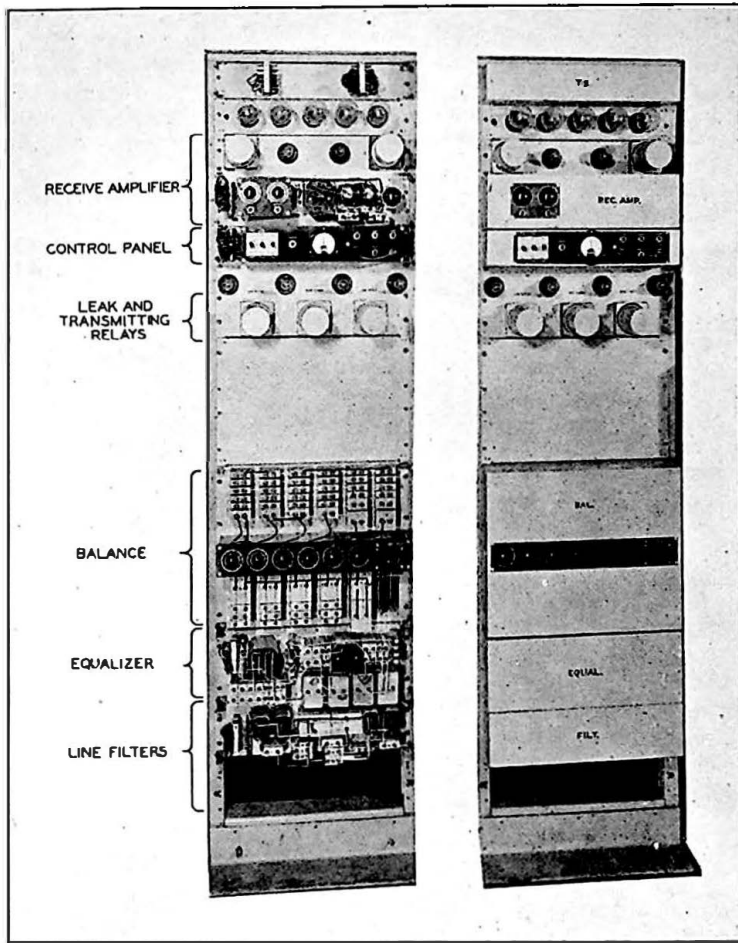

FIG. 6.—TERMINAL EQUIPMENT.

the distant cable and extension terminals is controlled by keys mounted on the control panel. A relay is provided for transmitting to the cable to ensure similar conditions for signals transmitted

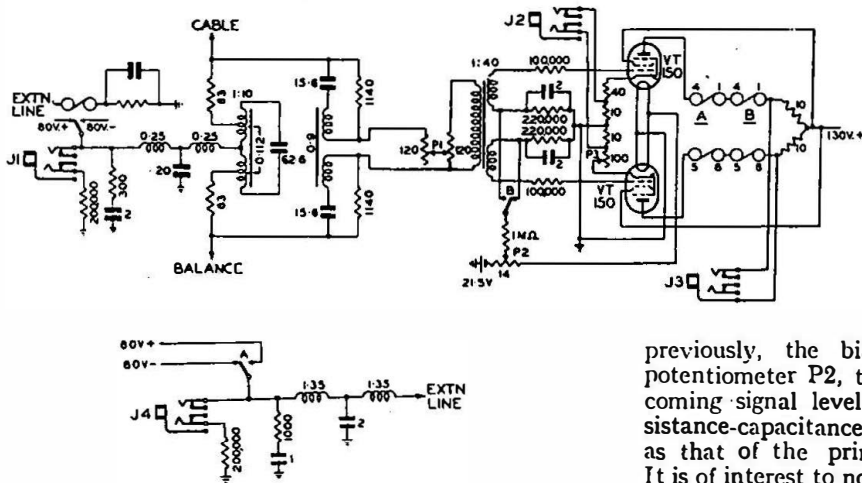

FIG. 7.—SCHEMATIC CIRCUIT DIAGRAM OF TERMINAL EQUIPMENT.

either from a distant station over the extension line, or from a local transmitter used for testing. A special low-impedance transmitting filter is provided on the cable side, and a standard Filter Frequency 4B in the extension line. These filters and the spark quenches for all the relay contracts, and the shunted condenser terminations for the extension line and leak relays (D and E) are mounted on the filter panel at the bottom of the bay.

It will be seen from Fig. 7 that the equaliser is balanced, and the shunt coil is in the form of an auto-transformer to reduce the tuning capacitance required to a convenient value. To obtain the required degree of balance, this coil is twin wound on a two-section bobbin, the windings on the two sections being in opposite directions. The construction of the series coil is similar. Both coils have a mumetal core of about one square inch cross-section with an air gap of 10 mils.

The construction of the balance is evident from Fig. 6. The potentiometers, fixed resistors and rheostats are wire wound. These and the capacitors are standard commercial components.

The push-pull amplifier is designed to provide double current signals of ± 8 mA for operation of the telegraph relays. The received signal is applied to the grids of the valves via an input transformer which is connected across the equaliser terminating resistor. The transformer has a primary inductance of 120 H and the turns ratio (primary to secondary) is 1:40. It is wound on a mumetal core of approximately one square inch cross-section.

The loss of this transformer when connected across the equaliser terminating resistor is approximately 1.5 db at 1 c/s.

The variable input control is in the form of a ganged potentiometer (P1) as shown, in order that the variation of the input control does not affect the value of the resistance terminating the equaliser and at the same time the resistance of the source to which the transformer is connected remains nearly constant.

The restoration of the D.C. component which is not transmitted by the transformer is effected by the telegraph relay B, as described

previously, the bias voltage being adjusted by potentiometer P2, to a value appropriate to the incoming signal level. The time-constant of the resistance-capacitance networks is 0.44 sec., the same as that of the primary circuit of the transformer. It is of interest to note that when the D.C. restoration circuit was not used the distortion of 5:1 signals at 80 bauds was 25 per cent., but with the D.C. restora-

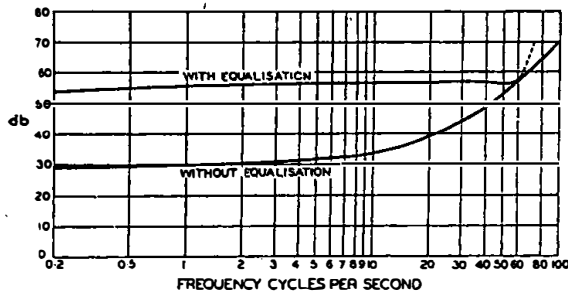

FIG. 8.—CALCULATED INSERTION LOSS OF CABLE WITH TERMINATING EQUIPMENT.

tion circuit connected this distortion was reduced to 2 per cent. One cathode resistor is made variable to compensate for difference in valve characteristics, and it also may serve to a limited extent as a means for correcting bias on the received signals. The cathode resistors also provide a suitable connection point for a cathode-ray oscilloscope for observations of the waveform of the received signals. The jack j2 is provided for this purpose.

The telegraph relay A provides the double current output signals for transmission to the extension line. A jack (J4) is connected in leak on the tongue of this relay to provide a connection point for the meter or a distortion measuring set to monitor the output signals.

The complete bay, when operated from A.C. mains via rectifiers, consumes about 200 W.

As finally set up, distortion on mixed signals at all speeds up to 80 bauds was between 5 and 8 per cent., without change of adjustments. These figures refer to simplex operation. For comparison, the distortion was measured on a cable having a lower KR of 86,000 Ω - μ F operated with equipment of older design with a modified Gulstad circuit. Over the range 50 to 80 bauds the maximum distortion on mixed signals could not be reduced below 15 per cent. with any fixed adjustment of controls, although by appropriate readjustment it could be reduced to 5 per cent. at any one speed.

Installation in Service.

Experience during the installation and setting up of circuits and the subsequent maintenance over a period of two years has demonstrated the simplicity of adjustment and the stability of the equipment.

The first installation of this type of equipment was at one end of a cable, KR 86,000 Ω - μ F, the apparatus at the remote end being of the conventional type. The remote station in addition to transmitting direct signals, also repeats signals from

a second and longer cable. The direct transmission from a Wheatstone transmitter at this intermediate station was satisfactory, good signals being received over a range of 50 to 80 bauds without change of adjustment on the receiver and with the designed termination. For this test the receiver was lined up at the higher speed. The signals repeated from the second cable however, were distorted and it was necessary to modify the component values of the valve receiver before good signals at a speed of 56 bauds were obtained. At this time an undulator was the only instrument available for monitoring the signals and, as this instrument does not show distortion below 20 per cent., it was not possible to measure the distortion accurately. This limitation was overcome later by the provision of a distortion measuring instrument at the valve receiver terminal, and it was then possible to determine the difference in distortion between the direct and repeated signals and to assist the intermediate station in reducing the distortion in the repeated signals.

The equipment provided on two other cables is installed adjacent to the M.C.V.F. telegraph terminals and the lining up and maintenance of the cable circuits are carried out with the distortion measuring sets provided on this equipment. One of the cables provides a teleprinter duplex point-to-point circuit and the other is a Wheatstone duplex circuit. These cables have KR values of approximately 30,000 and 50,000 Ω - μ F respectively. The use of distortion sets and the fact that similar types of terminal equipment are used at both ends of these cables greatly facilitated the installation. Balancing was carried out initially with a centre-zero voltmeter connected across the balance points of the termination, the ratio of resistance and capacitance of the balance sections being adjusted until the voltmeter was unaffected by the signals from the local transmitter. It was generally found possible to reduce the duplex distortion by this method to about 10 per cent. Final adjustment of the balance was, however, made with the aid of the distortion set. By adjustment of the first sections of the balance, i.e. the potentiometer controls, the duplex distortion over the speed range 0-80 bauds was then reduced to less than 5 per cent.

These circuits were adjusted initially by experienced officers, but three of the terminals are maintained by staff with no previous experience on submarine telegraph circuits. The Wheatstone circuit provided serves as a link in a long duplex circuit, which includes two other submarine cables and three V.F. telegraph links. The fact that such a circuit can be satisfactorily maintained without difficulty demonstrates the soundness of the design method.

Crystal Filters

R. L. CORKE, A.M.I.E.E.

Part III.— Quartz Crystal Resonators

U.D.C. 621.318.7 621.392.52

A brief description is given of the X-cut quartz crystal resonator with a simple explanation of its operation as an element of a filter.

THE X CUT RESONATOR

QUARTZ crystal resonators are prepared from native quartz crystals using a highly specialised manufacturing technique that has been described elsewhere.¹ In this article the interest is centred on the finished resonator and how it operates as a filter element, but it is desirable to describe briefly how the resonator is prepared in order to show the relationship between the resonator and the crystal from which it is made.

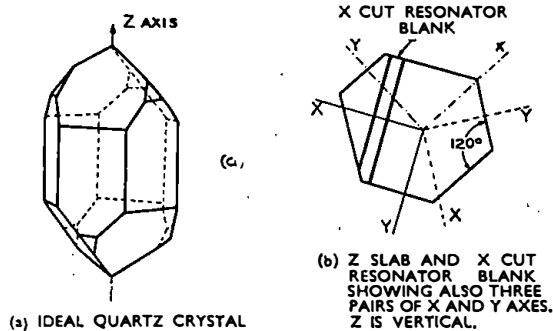

FIG. 1.—IDEAL QUARTZ CRYSTAL AND THE DIRECTIONS OF CUTS TO PRODUCE AN X-CUT RESONATOR BLANK.

An ideal quartz crystal has the form shown in Fig. 1 (a). Rarely are crystals found with this perfect shape; irregularities of growth, breakage during mining and erosion due to water are factors which reduce the quartz specimens available to shapes often very different from that depicted. Photographs of typical crystals are to be found in the article referred to above. The perfect crystal has the general appearance of a hexagonal prism terminated in a pyramid at each end. A piece called a Z slab sawn from such a crystal with both saw cuts perpendicular to the line joining the tips of the pyramids has the shape shown in Fig. 1 (b) when seen in plan. The angles between adjacent sides of this prism are always 120° so that opposite edges of the hexagonal face are parallel to each other. There are three sets of axes which are used as reference directions for defining the way the resonator is cut from the Z slab. The so called Z axis is perpendicular to the hexagonal face of the Z slab and is parallel therefore to the original datum line joining the tips of the pyramids. There are three Y axes, each at right angles to a pair of sides of the prism, and with each Y axis and the Z, there is a third called the X axis forming a set of three axes mutually at right angles to each other. There are thus three possible sets of axes, Fig. 1 (b), with Z common to all and any one set can be used for defining direction. The reason for these three sets of axes is simply that the

¹ P.O.E.E.J., Vol. 31, Part 4, p. 245 (January, 1939).

crystalline structure has “three-way” symmetry as the crystal is turned on its Z axis.

The resonator frequently used for filters is made from a slice sawn from the Z slab, with two saw cuts, Fig. 1 (b), perpendicular to any one of the X axes. This direction of cut is called the “X” cut. The slice of quartz, roughly rectangular in shape, is known as a resonator blank; this is later ground to a rectangular solid of the required size.

Piezo-Electric Properties.

The piezo-electric properties of crystalline quartz give rise to the following effects: When the resonator is mechanically compressed in the direction of the Y axis equal electric charges of opposite sign appear on the two larger surfaces, i.e. those parallel to the ZY plane, and the magnitude of the charge is proportional to the mechanical pressure. On releasing the compression the charges disappear, but reappear with signs changed when the resonator is subjected to a tension in the direction of the Y axis. This electro-mechanical coupling is reversible for when the resonator is placed between the plates of

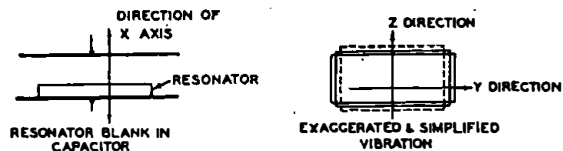

FIG. 2.—TO ILLUSTRATE VIBRATION OF X-CUT RESONATOR UNDER INFLUENCE OF ALTERNATING ELECTRIC FIELD.

a capacitor so that it rests on the lower plate, Fig. 2, then upon establishing a difference of potential from a direct current source between the plates so that an electric field traverses the quartz in the direction of the X axis, the quartz will expand or contract in the direction of the Y axis and at the same time contract or expand in the direction of the Z axis.² When the difference of potential is made zero the resonator assumes its original shape and upon reversing the sign of the applied potential the direction of the mechanical distortion changes sign. The amount of distortion is proportional to the potential.

The application of an alternating potential will cause the resonator to vibrate at the frequency of the applied potential. The simple arrangement of a capacitor for vibrating the resonator would not be satisfactory in practice since friction between resonator and plate would damp the vibration unduly. By replacing the capacitor electrodes with very thin conducting films of metal (usually gold)

² The mechanical distortion of a resonator under these conditions is more complicated than this, for other contractions and expansions occur. The simple conception will, however, suffice for the present description.

on both ZY surfaces and by holding the resonator in a clamp at its centre so that the clamp makes electrical contact with the metal films, but does not materially damp the vibration, an efficient resonator can be made. Under the influence of applied potentials the resonator and its electrodes are then free to vibrate in the direction of the Y axis with the ends of the resonator at any moment moving in opposite directions but with no movement along the centre line. The line of zero movement is called a nodal line. Due to the presence of other modes of vibration in the X cut resonator the nodal line is not parallel to the Z axis, but is inclined to it at an angle. A description of these extraneous modes of vibration and the methods used to reduce their effects to a minimum is described elsewhere.³ A generally satisfactory method which gives reasonable freedom from unwanted modes for an X cut resonator is for the dimension in the Z direction to be half the dimension in the Y direction.

Equivalent Circuit of Resonator.

If a resonator in a clamp is connected in a test circuit, as shown in Fig. 3 (a), and the meter readings are plotted against the frequency of the oscillator,

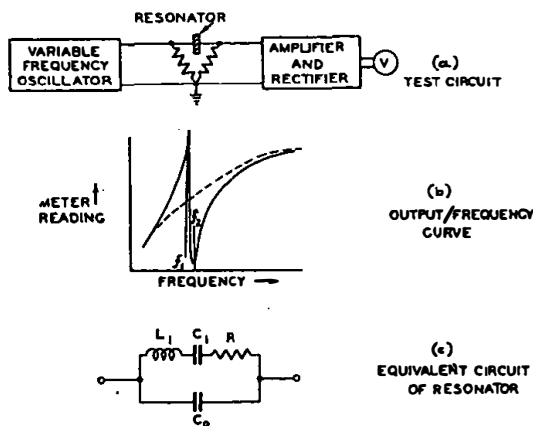

FIG. 3.—BEHAVIOUR OF RESONATOR IN TEST CIRCUIT.

the curve will have the general shape shown in Fig. 3 (b). At the frequency f_1 the resonator evidently has a low impedance, but at f_2 the impedance is high and the tendency of the curve is for output to increase with increased frequency as shown by the dotted line in the figure. This observed behaviour of the resonator can be simulated (see Parts 1 and 2) by replacing it with a circuit of the form shown in Fig. 3 (c). The resistance R represents the damping to which the resonator is subject. The components L_1 , C_1 and part of R do not exist as electrical elements; they are a convenient way of representing electrically the behaviour of the resonator in the test circuit. The capacitance C_0 , however, is the self-capacitance of the resonator when it is restrained from vibrating. The current passed by the resonator is the sum of two currents. One is the current in the capacitance C_0 and the other is the current which

neutralises the charges set free by the vibration of the quartz. The latter current reaches a relatively large value at the frequency f_1 since the resonator then vibrates strongly and the piezo-electric charges, being proportional to the mechanical displacement, are larger than at other frequencies for the same applied potential. The total current passed by the resonator at this frequency has thus a maximum value and this is interpreted as a state of low impedance or resonance which is simulated by L_1C_1 in the equivalent circuit. Therefore $\sqrt{1/2\pi L_1C_1}$ is equal to f_1 , the frequency of mechanical resonance in the Y direction.

Determination of the values of the elements forming the equivalent circuit may be made by a capacitance bridge and a test circuit similar to that shown in Fig. 3 (a). The frequencies f_1 and f_2 are found using this test circuit and the capacitance C_0 is measured with the bridge at a frequency of about 1 kc/s. The resonator is restrained from vibrating when the capacitance is measured. The elements L_1 , C_1 may be calculated from these results. The manner in which the elements and the frequencies vary with resonator dimensions is as follows:—

- (i) The frequency f_1 is inversely proportional to the length y measured in the direction Y; that is, $L_1C_1 \propto y^2/4\pi^2$.
- (ii) The equivalent inductance L_1 is proportional to the length x measured in the direction X, provided the ratio z/y is constant. The dimension z is measured in the direction of the Z axis.
- (iii) The ratio f_2/f_1 is constant for all X cut resonators if z/y is constant.
- (iv) The capacitance C_0 is the capacitance existing between two rectangular plates area zy separated by distance x with quartz dielectric. The expression (for x , y and z in cms.) is:

$$C_0 = 40.2 \times 10^{-14} zy/x \text{ Farad.}$$

The values of the elements L_1C_1 in the equivalent circuit of a resonator have extreme values judged by normal circuit standards. For instance, an X cut resonator with x , y and z respectively 0.1, 1.0 and 0.5 cm. would have the following equivalent values approximately:

$$L_1 = 23 \text{ Henrys, } C_1 = 0.016 \text{ pF, } C_0 = 2 \text{ pF, and } R = 3,000 \text{ ohms.}$$

The frequencies of this resonator would be:

$$f_1 = 264 \text{ kc/s and } f_2 = 265.06 \text{ kc/s}^4.$$

The efficiency of such a resonator operating in air at atmospheric pressure can be judged by the following comparison. The Q value of the resonator ($2\pi f_1 L_1/R$) is at least 10,000; it can be 10 or more times as great for resonators vibrating in a vacuum. An exceptionally good electrical circuit may not reach Q values greater than 350.

It is the high efficiency of the quartz crystal resonator that enables filters incorporating resonators to have a performance which cannot be equalled by coil-condenser filters.

³ B.S.T.J., July, 1934, p. 405.

⁴ See the Appendix to this Article.

Limitations Imposed by Resonators.

The use of resonators in filters imposes some severe limitations upon filter design. The most important limitation is that the ratio f_2/f_1 can never be greater than 1.004. The effects of this will be considered briefly towards the end of this article.

It is not practicable to manufacture resonators of the types described outside the range 50 to 600 kc/s approximately. The dimension y for 50 kc/s is about 5 cms. and it is difficult to find crystals large enough to enable such sizes of resonators to be made. At the higher frequency the resonator becomes so diminutive (y is about 0.4 cm. for f_1 equal to about 600 kc/s) that the manufacturing processes are difficult. However, by using different arrangements of electrodes and different cuts this range of frequency can be greatly extended in both directions.

Typical Resonators in Holders.

Quartz crystal resonators used in filters have, in the past, been mounted in a clamp type holder, Fig. 4, which illustrates a holder used for resonators in the frequency range 60 to 120 kc/s. The resonator (that in Fig. 4 has a resonant frequency of about 62 kc/s) is gripped along the nodal line by double springs fitted with hemispherical contacts at their extremities, which are inclined at an angle of 19° to suit the angle of the nodal line. This assembly is locked in the tubular case and sealed with wax. Connections are made to the electrodes by the spring contacts and the springs extend through the insulating disc to form soldering tags.

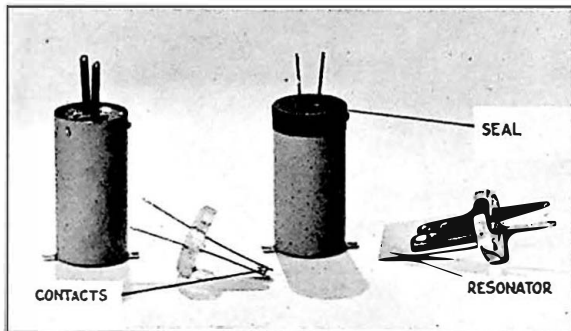

FIG. 4.—HOLDER FOR RESONATORS IN FREQUENCY RANGE 60-120 KC/S. LARGEST DIMENSION OF RESONATOR SHOWN IS APPROXIMATELY 4.25 CMS.

An improved technique is to solder wires to the surface of the quartz, to use these wires for support and for connection to the electrodes, and to mount the resonator within an assembly like a thermionic valve, as in Fig. 5, in which the resonator has a resonant frequency of 420 kc/s with the dimension y equal to 0.6 cm. approximately. A minute spot of metal is fired to the centre of each ZY surface of the resonator before the electrodes are applied. A fine wire (normal to the surface) is soldered to each spot and then gold is sputtered over both major surfaces to form the electrodes. The wires are secured to suitable supports carried in a valve type pinch and

the assembly is enclosed in a glass envelope which is evacuated and sealed and provided with a valve base. The advantages of this method of mounting and assembly are that the resonator is more posi-

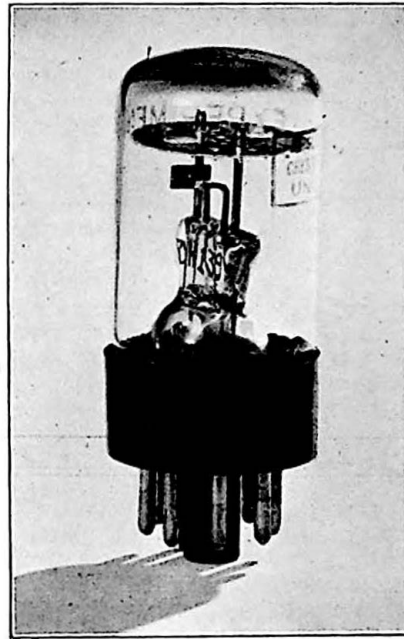

FIG. 5.—RESONATOR WITH WIRES SOLDERED TO QUARTZ. ILLUSTRATION APPROXIMATELY FULL SIZE.

tively held than in a clamp and it is completely protected from the effects of atmospheric humidity. High Q values are attainable due to the removal of air from the holder.

Simple Filter Application of the Resonator.

The use of resonators in lattice filters can be illustrated by a simple example which is intended to summarise the principles of lattice filters and resonators already described in this series of articles and to emphasise how the use of resonators limits the range of application of the particular type of section.

The most simple lattice filter in which quartz crystal resonators can be used has the circuit shown in Fig. 6 (a) with identical resonators in each series arm and equal capacitors in each lattice arm. The first step in a qualitative analysis of this circuit is to replace the resonators by their equivalent circuit (ignoring any resistance), Fig. 6 (b), and then to sketch the reactance curves of the arms, Fig. 6 (c).

An inspection of these curves shows that a pass band must exist between the frequencies f_1 and f_2 since, as explained in Part 1, the reactances are opposite in sign in this range. Also, since there is one interval in the pass band (see Part 2) there is one frequency of infinite loss. The lower cut-off frequency f_1 of this simple band pass filter is thus determined by the resonant frequency of the resonators and the upper cut-off frequency f_2 by their anti-resonant

frequency. It has already been stated that the X cut resonator of the type described has a maximum value of 1.004 for the ratio f_2/f_1 , which is therefore the maximum bandwidth ratio attainable

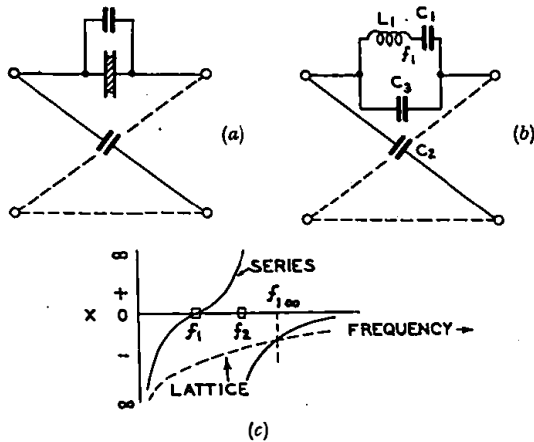

FIG. 6.—SIMPLE BAND PASS CRYSTAL FILTER—EQUIVALENT CIRCUIT AND REACTANCE CURVES.

by this filter with X cut resonators. It is, however, possible to design a filter of this type with a band width less than this ratio, for if each resonator has a capacitor connected across it the frequency f_1 is thereby unchanged but f_2 is moved towards f_1 and as the value of the capacitor is increased f_2 approaches more closely to f_1 . The thickness x of the resonator is proportional to the equivalent inductance L_1 , and in the design of a filter it is necessary to choose the nominal impedance of the filter section so that the value of x is suitable for resonator manufacture. In the appendix to this article a summary is given of a design of a simple filter of the type described.

APPENDIX

Design of a simple band pass crystal filter.

Analysis

The section is shown in Fig. 6. In the equivalent circuit (b) the capacitance C_3 is the sum of the self-capacitance C_0 of the resonator and the added capacitance. Using the numbering of Fig. 6 (c) the series and lattice arm impedances at frequency f are by Foster's Theorem (See Part 2) respectively:

$$Z_s = \frac{1}{j2\pi f C_3} \cdot \frac{f_1^2 - f^2}{f_2^2 - f^2}$$

and $Z_L = \frac{1}{j2\pi f C_2}$

The characteristic impedance is

$$Z_0 = \sqrt{Z_s Z_L} = \frac{1}{j2\pi f \sqrt{C_3 C_2}} \sqrt{\frac{f_1^2 - f^2}{f_2^2 - f^2}}$$

which at $f = \sqrt{f_1 f_2}$ becomes the nominal impedance

$$R_0 = \frac{1}{2\pi f_2 \sqrt{C_3 C_2}}$$

There is one peak of loss at f_∞ which is given by the equation $Z_s = Z_L$, that is

$$\frac{1}{j2\pi f_\infty C_3} \cdot \frac{f_1^2 - f_\infty^2}{f_2^2 - f_\infty^2} = \frac{1}{j2\pi f_\infty C_2}$$

Therefore $\sqrt{\frac{C_2}{C_3}} = \sqrt{\frac{f_2^2 - f_\infty^2}{f_1^2 - f_\infty^2}}$

(which for brevity will be called m .)

But $\sqrt{C_3 C_2} = \frac{1}{2\pi f_2 R_0}$

Hence $C_2 = \frac{m}{2\pi f_2 R_0}$ and $C_3 = \frac{1}{2\pi f_2 R_0 m}$

The remaining elements may be found in terms of C_3 , f_1 and f_2 by applying Foster's Theorem. Thus

$$L_1 = \frac{1}{4\pi^2 C_3 (f_2^2 - f_1^2)} \text{ and } C_1 = C_3 \frac{f_2^2 - f_1^2}{f_1^2}$$

The elements in terms of R_0 , m and the cut-off frequencies are therefore

$$L_1 = \frac{m R_0 f_2}{2\pi (f_2^2 - f_1^2)} ; \quad C_1 = \frac{f_2^2 - f_1^2}{2\pi f_1^2 f_2 m R_0}$$

$$C_2 = \frac{m}{2\pi f_2 R_0} ; \quad C_3 = \frac{1}{2\pi f_2 m R_0}$$

Design

The filter is required to have a pass band not more than 200 c/s wide centred on 60 kc/s and to provide a high loss to the frequency 61.8 kc/s.

Choice of cut-off frequencies f_1 and f_2

Put $\sqrt{f_1 f_2} = 60 \times 10^3$ c/s; let $f_2/f_1 = 1.001$.

Then $f_1 = 59.942 \times 10^3$ and $f_2 = 60.060 \times 10^3$ c/s

Frequency of infinite loss

Let $f_\infty = 61.8 \times 10^3$ c/s.

Element values in terms of R_0

Substituting the above values for f_1 , f_2 and f_∞ in the equation for m gives

$m = 0.967696$, and therefore $L_1 = 0.6427 \times 10^{-3} R_0$

$C_3 = 2.7384 \times 10^{-6}/R_0$; $C_2 = 2.5643 \times 10^{-6}/R_0$

Choice of R_0

Let $L_1 = 20$ H. This will lead to a resonator with a reasonable dimension x and makes $R_0 = 31,119$ ohms. Then $C_3 = 88$ pF; $C_2 = 82$ pF.

Resonator dimensions

For an X cut resonator with $z/y = 0.5$ resonant at f_1 the dimensions are found from the following equations:

$x = L_1/227$ cm; $y = 265/f_1$ cm. (for f_1 in kc/s).

From these equations for the values of L_1 and f_1 given above:

$x = 0.0881$ cm.; $y = 4.421$ cm; $z = 2.211$ cm.

The self capacitance of the resonator is:

$C_0 = 40.2 \times 10^{-14}$ yz/x Farad.
= 45 pF.

The added capacitance across the resonator is thus

$C_3 - C_0 = 37$ pF.

(Further reference to this design will be made in Part 4.)

The Unit Bay 1B Coaxial Cable Transmission System

R. A. BROCKBANK, Ph.D., B.Sc., A.M.I.E.E., and
C. F. FLOYD, M.A., A.M.I.E.E.

Part I. General Description of the System

U.D.C. 621.395.44

This is the first of a series of four articles describing the Unit Bay 1B coaxial cable transmission system which is being installed throughout this country to provide multi-channel telephone circuits on trunk routes.

History.

IN 1935, the Post Office undertook the design of the first coaxial cable system to be installed in this country. The route chosen for this full-scale trial was from London to Birmingham, and by early 1938 the cable had been laid, repeater equipment installed, and initial overall tests completed. Several demonstrations of the performance of the system were given, and it was then handed over to part-time traffic on April 12th, 1938. The system and its initial performance have been described by Mr. A. H. Mumford¹ in a paper which covered the whole equipment involved in the link between the audio-frequency terminations. The system was shortly afterwards brought into full-time traffic, except for a short daily test period, and it has continued in service throughout the war. The present traffic loading is 160 speech circuits.

As soon as initial tests on this system had indicated that coaxial cable transmission was a workable and economic proposition, the Post Office decided to extend the system to Manchester. The same type of equipment was used as on the London-Birmingham route, and the system was introduced into traffic in January, 1940.

When the design of the London-Birmingham system was commenced in 1935, very little was known of the art of wide-band transmission at these relatively high frequencies (2 Mc/s), but by 1939 theory and technique had shown great advances. The performance and testing of the London-Birmingham system had also added valuable information which could not have been obtained without a full field trial. As a result, therefore, it was concluded in 1939 that the London-Birmingham equipment, although it was performing very satisfactorily as an initial experiment on wide-band transmission, was not suited to meet the high standard of transmission and reliability which it was then desired to obtain on new trunk circuits. It was considered undesirable that this type of equipment should be installed on any further systems and, since it was evident that policy, strengthened by urgent war developments, would require the extension of the coaxial cable network, it became necessary to make available at the very earliest moment an improved design of equipment which would meet all anticipated requirements.

Standardisation of Coaxial Cable Systems.

It was evident that if the coaxial cable network of the country for multi-channel telephony was

to develop economically and flexibly standardisation of equipment would be essential. This would automatically involve the fixing of the bandwidth, the type of cable, the maximum repeater spacing and the overall noise output. All these factors are interdependent and a careful study was conducted to select an optimum design. The following characteristics were finally fixed for the standard system:

- (a) An air-spaced coaxial tube with copper conductors having an internal diameter of outer conductor of $\frac{3}{8}$ in.
- (b) A working bandwidth of 60-2,788 kc/s giving a capacity of 660 circuits with a 4 kc/s spacing between channels, and
- (c) A repeater spacing not exceeding 6 miles.

The design of this standard equipment was put in hand but, before it was completed, war demands necessitated a temporary change in policy. New systems had to be provided as a matter of urgency, and since only comparatively small batches of circuits were required immediately, it was considered to be a justifiable if not an essential economy to increase the spacing between repeater stations, thereby saving equipment and buildings and reducing installation and maintenance work. A 12-mile spacing has, therefore, been generally employed, though in one instance the spacings varied between 15 and 25 miles. Most of the systems with 12-mile repeater spacings will be suitable for conversion to the standard 6-mile system when conditions permit.

It was found that with the new design all the equipment required at each repeater station could be contained on a single 7 ft. 6 in. bay unit in contrast to the three bays which were involved on the London-Birmingham equipment. The title of Unit Bay 1B was given to the standard bay of repeater equipment which would be installed in each 6-mile repeater station. Although the term Unit Bay 1B applies specifically only to the standard 6-mile system, it has become common practice to use this term also for non-6-mile systems utilising modified Unit Bays 1B. Differences between the 6-mile Unit Bay 1B and modifications thereof must not be overlooked, and it is hoped that the modified versions now extant may later be replaced. Since this article is concerned chiefly with the 6-mile Unit Bay, it will be desirable on occasion to differentiate between 6-mile and non-6-mile versions, and, for this purpose, the prefix "standard" will be introduced when the 6-mile system is explicitly concerned. Due to the change in policy dictated by the war, it has not yet been possible to bring a standard system into traffic, though it is expected that this will be possible in the near future.

It should be noted that a Unit Bay 1B system

¹ P.O.E.E.J., Vol. 30, pp. 206 and 270, and Vol. 31, pp. 51 and 132.

I.P.O.E.E. Printed Paper No. 164.

consists of the wideband transmission link only and does not include any frequency translating equipment at the terminals.

Comparison with the London-Birmingham System.

A certain amount of publicity was attached to the design and performance of the original London-Birmingham equipment in 1938. As it has not, until now, been possible to publish further information regarding coaxial cable development in this country, it is of interest to compare very briefly the standard Unit Bay 1B system with the early experimental repeater equipment. The Unit Bay 1B equipment represents an entirely new constructional design and many improvements and refinements have been incorporated, a few of which are given below.

The most outstanding improvement in the H.F. circuit is the new compact repeater which has a performance virtually independent of all normal power supply variations and temperature changes. The H.F. equalisers are now more accurate and stable, and the temperature equalisers are switched automatically from the control terminal instead of requiring manual operation at each repeater station. An automatic gain control device ensures that the overall gain of the system remains constant. The scope of the supervisory and control circuits has also been considerably extended, e.g., in addition to the automatic changeover it is now possible to changeover any repeater to its standby from the control terminal. From the operational aspect, perhaps the most striking improvement is in the signal/noise ratio, which is at least 12 db. better than on the London-Birmingham system. It has been recorded that when a 110 mile system was recently completed and handed over to the local staff, observers thought it was disconnected because of the absence of any background noise.

The Coaxial Cable.

The Unit Bay 1B repeater system operates over two coaxial tubes and requires a minimum of eight telephone pairs to provide the full supervisory and control facilities. The type of cable and its gain/frequency characteristics, for which the repeater equipment has been designed to operate, are shown in Fig. 1. Each tube in the cable consists of a $\frac{3}{8}$ in. internal diameter copper cylinder formed by a spiral of interlocking copper tapes overlaid with two 5 mil steel tapes; the inner conductor of each tube is a copper wire 0.104 in. diameter, which is held centrally at intervals of a few inches by insulating disc spacers slotted to enable them to be forced on to the wire. The two coaxial tubes are laid up together with twelve 20 lb. telephone quads in the interstices, to form a circular section which is then lead sheathed

overall to a diameter of 1.14 in. The use of 2-tube cables has certain advantages over the earlier 4-tube cables, e.g., crosstalk requirements are less severe and the cable forms a self-contained system which is independent of faults or conditions which might occur between systems on contiguous tubes.

The stability of the electrical characteristics of tubes having an outer conductor of spiral tapes has, unfortunately, not been entirely satisfactory in practice. Variations in contact resistance between the tapes result in the current taking a more or less spiral path, and the longitudinal component of the resultant magnetic flux is a source of increased loss and crosstalk. To overcome this trouble and, incidentally, produce a cheaper cable, an American development is to construct the outer conductor of a single longitudinal tape bent round the circumference to form a cylinder with a longitudinal butt joint. Experimental lengths of such cable have been laid in this country, and the first results are encouraging, though the flexibility of the cable has been considerably reduced. The characteristic impedance of both this and the interlocking copper tape type is 75 Ω .

The supervisory system of the Unit Bay 1B has been designed to operate over the interstice telephone pairs provided in the cable and it is not, in general, satisfactory to attempt to operate the system over any other type of circuit.

Joining faults have, on occasion, given rise to considerable trouble. The recent fault liability is however satisfactory, and it should still further be improved by a stronger joint which is being introduced.

Repeater Station Buildings.

Three new types of building have been introduced for housing intermediate repeater stations on coaxial

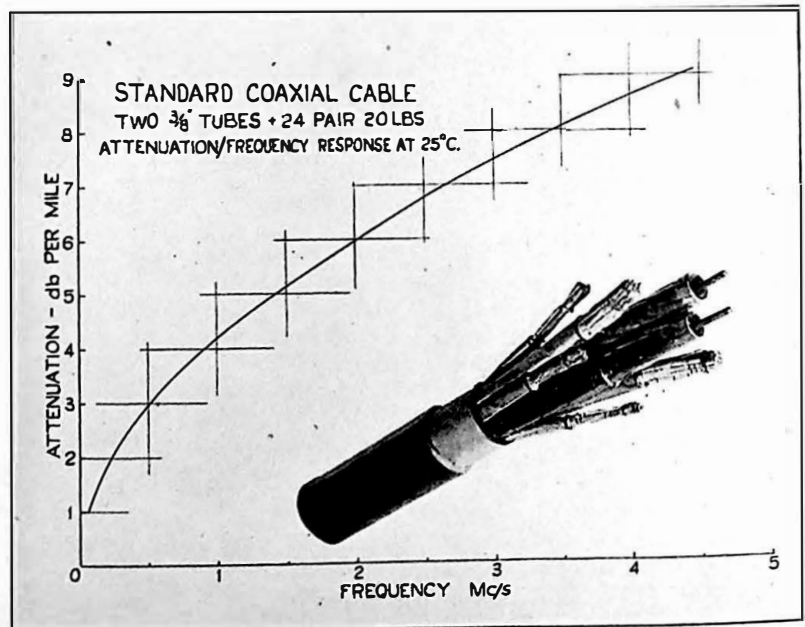

FIG. 1.—TYPE OF CABLE AND GAIN/FREQUENCY CHARACTERISTIC.

routes. The smallest, type "CR1" (8 ft. \times 7½ ft. \times 9 ft. high), is suitable where standby power plant is not required, that is, at dependent stations. For power-feeding stations where local standby engine-generator plant is necessary the type "CR3" (27½ ft. \times 10½ ft. \times 9 ft. high) is used and this contains an apparatus room and an engine room. The type "CR2" (22 ft. \times 10½ ft. \times 9 ft. high) consists of an engine room only and is added to existing buildings where additional power plant cannot be accommodated but where an apparatus room already exists. Oil storage is available external to the engine room. The normal accommodation in each of these buildings permits installation of two 7 ft. 6 in. high bays, although type "CR3" could contain four if necessary. An electric light supply from the nearest local mains is generally installed and where possible a telephone extension to the local exchange is a great convenience in emergencies.

There is no standard design for coaxial terminal station buildings. These must be able to contain a number of 10 ft. 6 in. high bays of frequency translating and carrier generating equipment as well as the terminal repeater equipment bays and are therefore usually large buildings in or near centres of considerable telephone traffic density. Often a single new building houses a variety of carrier equipment in addition to the coaxial terminal, and this is an advantage as it

The High Frequency Circuit.

A simplified block schematic of the H.F. transmission path is shown in Fig. 2.

In each direction of transmission the H.F. signals produced by the modulating equipment are transmitted over the H.F. repeater system, and demodulated at the receiving terminal. The two pilot frequencies, which are transmitted continuously over the H.F. circuit, are necessary for the control and supervision of the cable and repeater equipment, and are obtained from the carrier generating equipment. One of these pilots is also used to synchronise the carrier frequencies at the two terminals.

The method of equalising the H.F. circuit is different from that employed on the London-Birmingham system. In the standard Unit Bay system, all repeaters have a gain of 48 db. which is constant from 60-2,852 kc/s, and as the equalisation is effected at the input of each repeater, the repeater output level is constant for all channels. This level on the standard equipment is -13 db. relative to the sending 2-wire level, and the level of each pilot is +3 db. relative to the same zero level point. Since the repeaters at the terminals are exactly similar to those at intermediate repeater stations, the maximum channel level available to the demodulation equipment is -13 db. At the transmitting terminal the minimum channel level required from the modulating equipment is -45 db.

The circuit for a typical intermediate repeater station is included in an elementary form in Fig. 2, and consists essentially of an input equaliser followed by a repeater. The equaliser consists of the line equaliser unit, which compensates for the normal gain/frequency characteristic of the previous cable section, and a smaller temperature equaliser unit which is used to compensate for the small variations which occur in the cable due to seasonal temperature changes. The repeater unit actually consists of two identical repeaters, one of which is usually termed the main (or A) repeater, and the other the standby (or B) repeater. The latter is brought into circuit automatically if the main repeater fails. The coaxial cables are led into the repeater equipment at each station through filters (not shown in Fig. 2) which separate the H.F. signals from the 50 c/s power which is also superimposed on the coaxial tubes.

The circuits at the terminals are complicated by the pilot equipment. Consider first the circuit of the lower frequency pilot: this is obtained from the carrier-generating equipment at a frequency of 60 kc/s which is then passed into a frequency converter and level stabiliser unit from which it emerges as a 300 kc/s pilot at a predetermined level which remains constant and independent of small variations in the level of the 60 kc/s input.

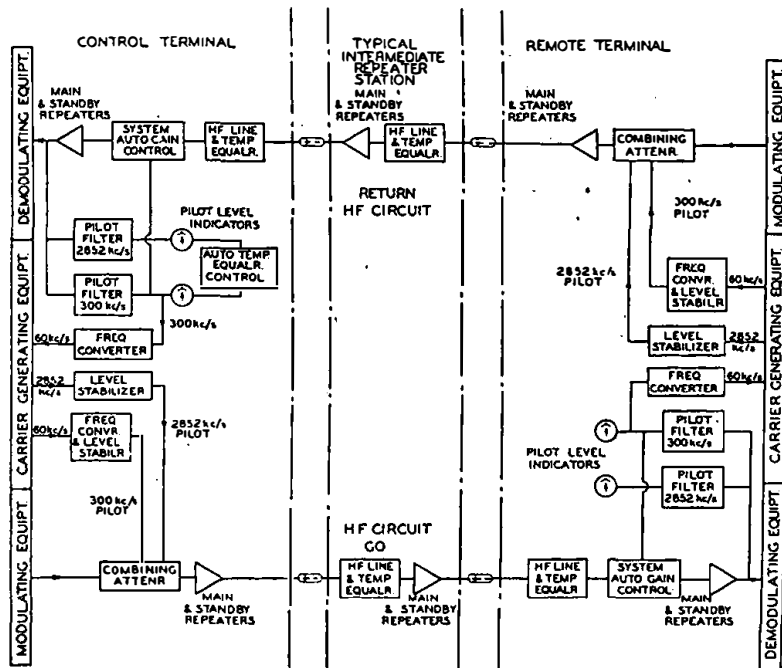

FIG. 2.—BLOCK SCHEMATIC OF H.F. TRANSMISSION PATHS.

permits better maintenance staff arrangements. Standby power plant is needed for the coaxial terminal supply and as all the major alarms for the whole system are extended to the terminal stations no additional alarm extensions are normally needed at any other repeater stations on a route.

This 300 kc/s signal is then teed on to the line at the transmitting terminal. At each repeater station along the route this pilot is used to indicate a break in the H.F. circuit, and also to switch automatically from main repeater to standby if the former fails. At the receiving terminal, it is selected from the line and used:—

- (a) to indicate the 300 kc/s level;
- (b) to operate an automatic gain control device which is inserted before the terminal repeater;
- (c) to operate, in conjunction with the high frequency pilot, a circuit for providing automatic temperature equalisation of the route;
- (d) to be re-converted to 60 kc/s for the purpose of synchronising the carrier generating equipments at the two terminals.

The high frequency pilot is accepted at 2,852 kc/s from the carrier-generating equipment, stabilised and teed on the line. It performs no major function along the route, and at the receiving terminal it only operates a level indicator and the automatic temperature equaliser circuit.

The pilot arrangements are identical in each direction of transmission except that the automatic temperature equaliser is operated only from the return direction.

Power Distribution.

The repeater system is fully A.C. mains operated on all major equipment, power for this purpose being taken from power supply companies' single-phase 50 c/s mains. It is evident that the reliability of the power supply is of the utmost importance, and a standby self-starting engine-generator set is, therefore, necessary at each power feeding point to cover failure of the mains supply. A great increase in reliability and saving in initial power plant costs has resulted from the method of feeding power from a single supply point to groups of repeater stations using the coaxial tubes as power cables. This power feeding arrangement has been perpetuated from the London-Birmingham system, where it proved to be very satisfactory, and it now permits up to five repeater stations to be fed from one power supply point. Fig. 3 illustrates the power transmission arrangements on a typical portion of a Unit Bay 1B coaxial route comprising one terminal feeding one dependent station, and one power-feeding intermediate station feeding two dependent stations on one side and one dependent station on the other side. Power is supplied to the cable at 350 volts 50 c/s, which is the maximum safe operating value permitted, and at this voltage the potential drop in the tubes prohibits the feeding of more than two dependent stations in series on each side of a power feeding station with the standard cable and with 6-mile repeater section lengths.

Great care has been taken to provide high-voltage protection on the Unit Bay and to prevent cable repairs being undertaken without first removing

power. All high-voltage power filters in cable-termination boxes are enclosed and access cannot be obtained to them or the cable head for testing purposes

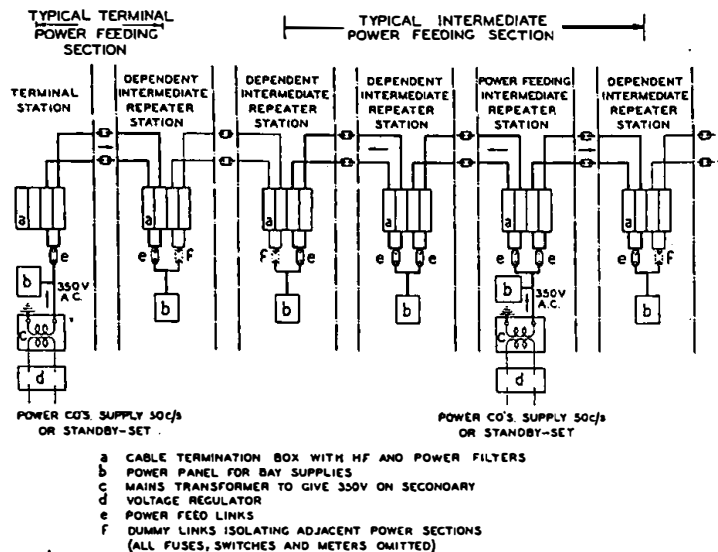

FIG. 3.—BLOCK SCHEMATIC OF POWER TRANSMISSION ARRANGEMENTS.

until isolating plugs are moved which place short-circuits on the tubes before the termination boxes can be opened. The links (e) and (f) are contained under a padlocked cover, and access to them can be obtained only when the power is switched off. Each link is also individually engraved with the name of the feeding and fed stations, so that while the officer in charge of the cable repair holds the appropriate link in his possession, he is assured that the power supply over the particular section has been removed.

Considerable loss of traffic time can usually be saved when a cable fault occurs without seriously affecting H.F. signals, by changing over the dependent repeater stations in the damaged section to local emergency sources of power, e.g., the local lighting mains or a portable petrol-electric set, and thus maintaining the H.F. circuit without power on the cables. Arrangements whereby this can be done are installed in all dependent stations as standard fittings on the Unit Bay 1B system. The power consumption per system of a dependent station is approximately 250 watts, of a power feeding station about 350 watts, and of a terminal station about 1,000 watts, so that allowing for cable transmission losses the maximum load on the supply mains at any power-feeding station will not exceed 1,600 watts.

Each Unit Bay 1B contains a power panel capable of operating from 250 to 350 volts A.C., and from which is derived the various A.C. and D.C. supplies necessary to energise the valve and relay circuits on the bay, together with external outlets for operating portable test equipment.

The Supervisory and Control System.

The comprehensive supervisory and control system provided on the London-Birmingham route has proved to be fully justified and the basic methods have been incorporated in the Unit Bay 1B system.

The general principles which have governed the design of the present supervisory control system are:—

- (a) Unified route control vested in the control terminal.
- (b) Rapid analysis and location of faults.
- (c) That breakdown in a supervisory or control circuit should not interrupt the H.F. transmission and should provide its own alarm if possible.

The first principle has been carried much further than on the London-Birmingham system; for

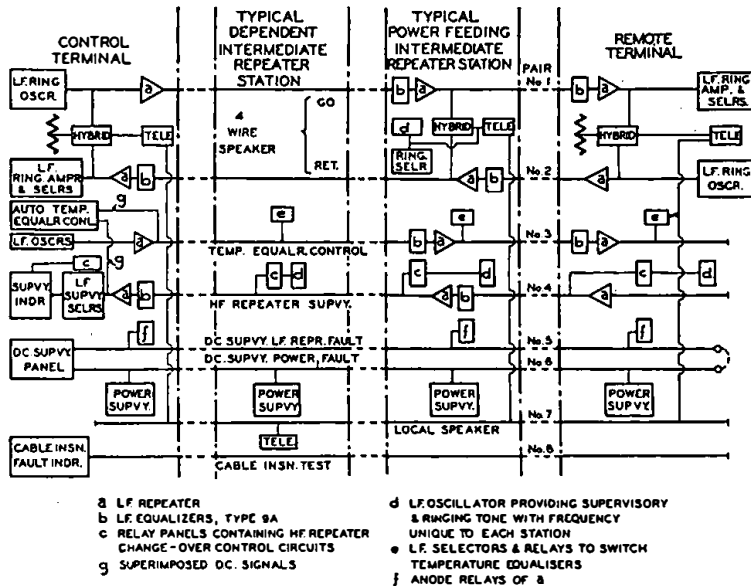

FIG. 4.—BLOCK SCHEMATIC OF 8-PAIR SUPERVISORY SYSTEM.

example, the temperature equalisation is effected completely from the control terminal and the officer at this station also has the facility of changing over any main or standby repeater on the route.

The supervisory and control circuits require the use of eight of the interstice pairs laid up in the 2-tube cable. These telephone pairs are brought out separately from the cable at every repeater station and terminate on test tablets in close proximity to the Unit Bay to which they are wired.

Fig. 4 indicates in a simple block form how the eight pairs are utilised to provide the following facilities:—

- (a) A 4-wire repeated speaker circuit with voice-frequency selective ringing which is brought out at power-feeding and terminal stations.
- (b) A temperature-equaliser control circuit and switching indicator. Correction for the effect of temperature changes in the transmission response is done from the control terminal by a voice-frequency selective system which

switches temperature equaliser networks as required along the route.

- (c) An H.F. repeater supervisory circuit with a repeater fault indicator panel at the control terminal. This has a separate indicating lamp for every repeater station on the route and the changeover of any main repeater causes the appropriate lamp to glow and also raises an audible station alarm at the control terminal.
- (d) A control circuit to enable any main repeater to be changed to its standby by remote switching from the control terminal. This provides a rapid means of testing standby repeaters without visiting individual repeater stations.

- (e) A L.F. repeater valve failure alarm with location facilities at the control terminal. This D.C. supervisory circuit informs the control terminal of the failing emission of any valve in the L.F. repeated circuits.

- (f) A power failure alarm with location facilities at the control terminal. The failure of any one of the 4 V A.C., 250 V D.C., 40 V D.C. or 60 V D.C. supplies on any bay, operates an alarm at the control terminal and the faulty station is located by a calibrated dial and meter on a D.C. supervisory circuit.

- (g) A cable insulation fault alarm. Warning is given of the ingress of moisture to the telephone pairs of the cable by a circuit which operates when the insulation resistance falls below 20 M Ω.

- (h) A local 2-wire speaker circuit with magneto-generator ringing which is available at all repeater stations.

The two system pilots provide certain additional control facilities as indicated in Fig. 2, viz. :—

- (a) Terminal pilot level indicators. The received levels of the lower and higher frequency pilots are shown on meters, thus giving a continuous indication of the performance of the H.F. circuit.
- (b) Automatic temperature regulation. The received pilots also serve to operate a device which automatically carries out the temperature equaliser switching referred to in (b) above. The same equalisation is applied in both directions of transmission, though the control is only operated from the return direction.
- (c) Automatic gain regulator. The received lower frequency pilot operates a variable gain device which maintains a constant gain on the system at 300 kc/s.

The Measurement of Crosstalk in Telephone Apparatus with an Artificial Voice and a Weighted Transmission Measuring Set

L. S. CRUTCH,
B.Sc.(Eng.), M.I.E.E.
(Siemens Brothers & Co. Ltd)

U.D.C. 621.395.8 621.317.341.1

The article describes a method of crosstalk measurement on multi-channel carrier equipment which utilises an artificial voice in conjunction with a weighted transmission measuring set. The use of an artificial voice as the disturbing source enables standard test conditions to be reproduced more rapidly than is possible with normal methods employing the human voice, a feature which is important in connection with large-scale production testing. As a standard transmission measuring set is normally available for other purposes use is made of this apparatus, suitably weighted, and a psophometer is not then required.

Introduction.

CROSSTALK in telephone apparatus can arise from several causes, and the ultimate effect on the listener must be considered for all circumstances. Simple overhearing and external noise are the only effects arising in audio telephone systems; but new effects occur with multi-channel carrier telephone equipment.

To ensure satisfactory operation of equipment it is usual to specify conditions of speech input to certain channels and place a limit on the disturbance which can be permitted on the remaining channels. Some of the test conditions specified and the method of obtaining results have been tedious, and the large-scale production of multi-channel carrier equipment for war purposes emphasised the need for a quick and reproducible method of carrying out this work.

A psophometer is used for measurements on equipment at the factory testing stage and also on complete systems after installation. In this way it provides a convenient and reproducible method of measurement, but it lacks a corresponding source of interference which is equally stable. It is obvious that the measurements are only reproducible if the source is stable. It has been recognised that the human voice is not ideal as a stable source, and a number of proposals have been made for sources which did not suffer from the defects of a single frequency measurement, and yet had the reproducible character which the voice lacks.

Furthermore, when the source is the human voice, it is necessary to specify the type of telephone to be used and the level with respect to reference volume at which the talker is to speak. The test conditions for the apparatus may be devised to separate out effects due to simple couplings from those due to non-linearity in common equipment, or may attempt to simulate the worst conditions from all causes when handling traffic.

To meet this need it was decided to design a source which should be equivalent to the output from a telephone transmitter when spoken into by a human voice. Such a source could be amplified or attenuated to give any desired testing level and applied to as many circuits simultaneously as the test required, provided that precautions were taken to avoid the simultaneous application of peak power to all channels.

An "artificial voice" should fulfil as far as possible the following conditions:

- (1) It should produce a spectrum derived from the fundamental frequency of the average human voice, and should be weighted in accordance with the relative amplitudes and occurrence of the components at normal conversational level.
- (2) The output should fulfil the conditions of (1), but should be further weighted in accordance with the frequency characteristic of an average telephone transmitter.

Information on condition (1) could have been obtained only by lengthy investigation into the characteristics of the human voice, but fortunately such information was already available¹. Information on the frequency characteristics of telephone instruments was also readily available, and the standard Post Office Telephone No. 162 was chosen as a representative type.

Fig. 1 shows (a) the peak pressure of speech from a composite test of three male voices, each value

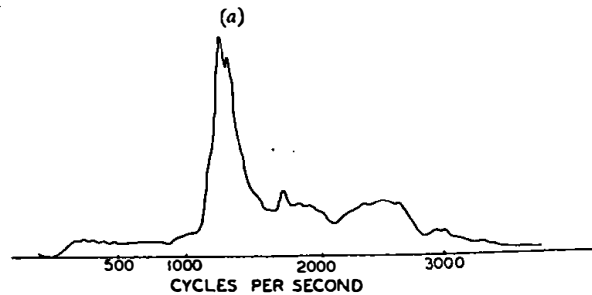
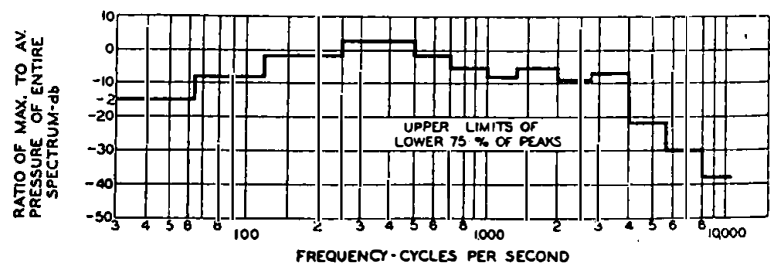

FIG. 1.—(a) PEAK PRESSURE OF SPEECH.
(b) FREQUENCY RESPONSE OF P.O. TELEPHONE No. 162.

¹ Speech and Hearing, Harvey Fletcher, *B.S.T.J.*, Oct. 1929. C.C.I.F. Proceedings 1931 (App. IV to Q.1 to the 4th Committee).

being the ratio of the maximum instantaneous pressure integrated over $\frac{1}{3}$ second to the average total pressure and (b) the frequency characteristic of the telephone transmitter (Post Office Telephone No. 162).

Fig. 2 shows the required frequency characteristic of the artificial voice weighted in accordance with the

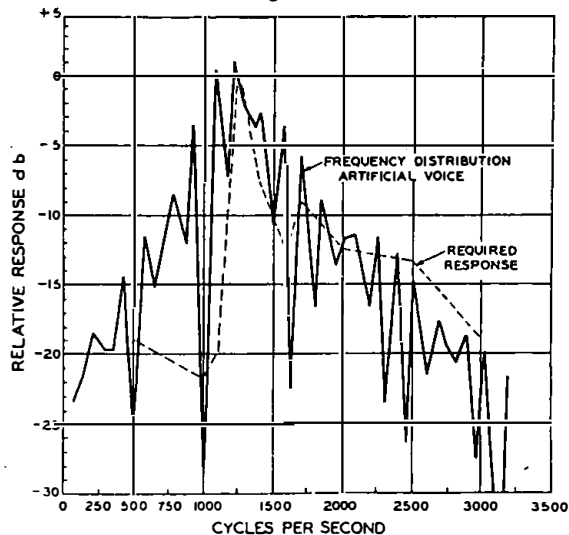

FIG. 2.—OUTPUT FREQUENCY CHARACTERISTIC OF THE ARTIFICIAL VOICE.

conditions of Fig. 1 and the output spectrum as obtained from the device which is now to be described.

The "Artificial Voice."

The design of this artificial voice can best be described with reference to the schematic circuit shown in the diagram of Fig. 3.

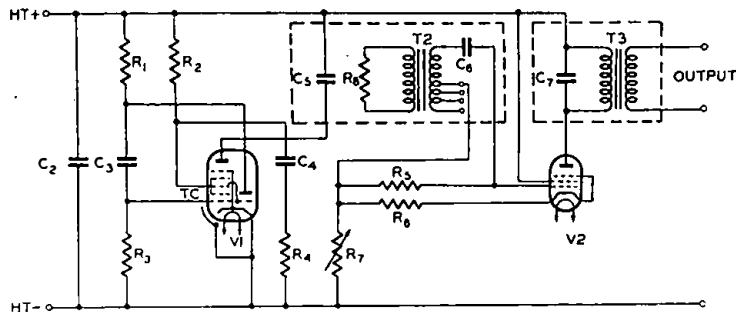

FIG. 3.—SCHEMATIC DIAGRAM OF ARTIFICIAL VOICE UNIT.

The triode hexode V1 is cross-coupled between grids and anodes to function as a multivibrator, the fundamental frequency of about 100 c/s being determined by the values of condensers C_3 and C_4 and the resistances R_3 and R_4 . The output from the hexode anode is fed into the amplifying valve V2 through a transformer network T2. The frequency response characteristic of this network, in conjunction with the transformer T3, gives an output substantially in accordance with the broken line of Fig. 2. Tappings on the secondary winding of T2 compensate for different characteristics of the multivibrator valve

V1, and resistance R_7 in the feedback circuit of valve V2 provides the main output control. An analysis of the spectrum made with a wave analyser is shown in the full line of Fig. 2, from which it will be seen that the output below 1,000 c/s is in excess of requirements. Since a modification to correct this appeared to be complicated it was decided to retain the greater output, and tolerate the rather more severe conditions of test.

The equipment for which this source was first designed required three speakers with measurements on a fourth channel. Accordingly three units such as described were required, and it was found necessary to use different fundamental frequencies for each unit or large amplitude beats of very low frequency were produced between the three units. Such an arrangement is also desirable since the fundamental frequencies of three voices would in general be different; accordingly the three units were made to have fundamental frequencies of 90, 110, and 130 c/s, respectively.

The source produces a continuously repeated spectrum at reference volume, the output being monitored on a decibelmeter previously standardised on a speech voltmeter.

Measurement of "Continuous Peak" Interference.

As a source of interference for crosstalk measurements on apparatus, it must be remembered that continuous peak energy is produced by the artificial voice, thus the conditions are not quite the same as occur with talkers speaking at a certain level with respect to reference volume.

For the test conditions using the human voice, it is laid down that the peaks of speech shall reach a certain level with respect to reference volume, and the peak reading of the psophometer shall not then exceed a given value. Thus an observer using a psophometer under these conditions is handling an instrument the meter deflection of which is changing rapidly from instant to instant, and is trying to assess peak values which occur at irregular intervals and may last only a short time. In this respect the observed deflection is a function of the dynamic characteristic of the measuring instrument. It is the usual practice when making these measurements to ignore large peaks the duration of which is too short to observe their maximum reading, and to observe the value which re-occurs at short intervals and retains its maximum long enough to be read with certainty.

When a source is used which produces a continuous peak signal it follows that a continuous peak reading is obtained, a feature which makes observations easier to record and to repeat and less dependent on the damping of the meter.

Use of a Transmission Measuring Set preceded by a Weighting Network.

The psophometer is a relatively costly and complicated piece of apparatus. It seems uneconomical to

provide a high grade transmission measuring set for checking the insertion gains and losses of the various parts of the apparatus, and, in addition, a psophometer of equal or greater complexity to measure the unwanted transmission between the parts of the equipment.

The difference in the units of calibration of these two instruments is not really significant. Although crosstalk is usually specified in millivolts, as an E.M.F. or a P.D. according to the conditions of the connected circuit, the severity or otherwise is usually judged by the signal-to-noise ratio. To obtain this the crosstalk voltage must be converted to a decibel ratio with respect to zero test level for the particular circuit, so that a direct measurement in this form eliminates the conversion. Thus the addition to a normal transmission measuring set of a weighting network and, if needed, some extra amplification, produces the equivalent of a psophometer so far as a single frequency calibration applies.

Linear rectification may, however, be employed in the transmission measuring set, whereas square law rectification is specified for a psophometer. In the particular T.M.S. employed, diode rectification was used as the linear method has advantages in the design. Increased sensitivity together with the weighted characteristic was obtained by adding a 2-valve unit in front of the T.M.S. The weighting network formed the interstage coupling between the first and second valves and determined the response of the system. The output from the second valve was connected to the first stage of the T.M.S.

Fig. 4 shows a photograph of a testing apparatus trolley, which includes the transmission measuring set, a crosstalk measuring attachment and the panel which provides three sources of artificial voice.

It is in the rectifier system that the arrangement described departs from the practice of the psophometer and most noise meters, in that a linear and not a quadratic system is used. For a sine wave input to either type the ratio of current outputs for the two conditions is well known. For a complex wave, the relation is not so easily stated, and for the linear system depends upon the relative phases of the component waves. In any case it is assumed that the frequencies of the complex wave are not harmonically related, and do not combine together to give an absolute peak at any time. If the number of components is large, this assumption is justified.

The output from the square law rectifier will be the root mean square of the outputs of the several components of the wave. The output from the linear rectifier cannot be expressed so simply, but it has been shown that if the components are of equal magnitude and not in harmonic relationship, then for two components the average output is about 1.27 times the individual outputs, and for four components it is about 1.8 times, and as the number of components increases the rule of summation approaches nearly that of the root mean square addition.

Comparison of Psophometer and Weighted T.M.S.

The checking of the weighting network was a straightforward insertion loss measurement using a

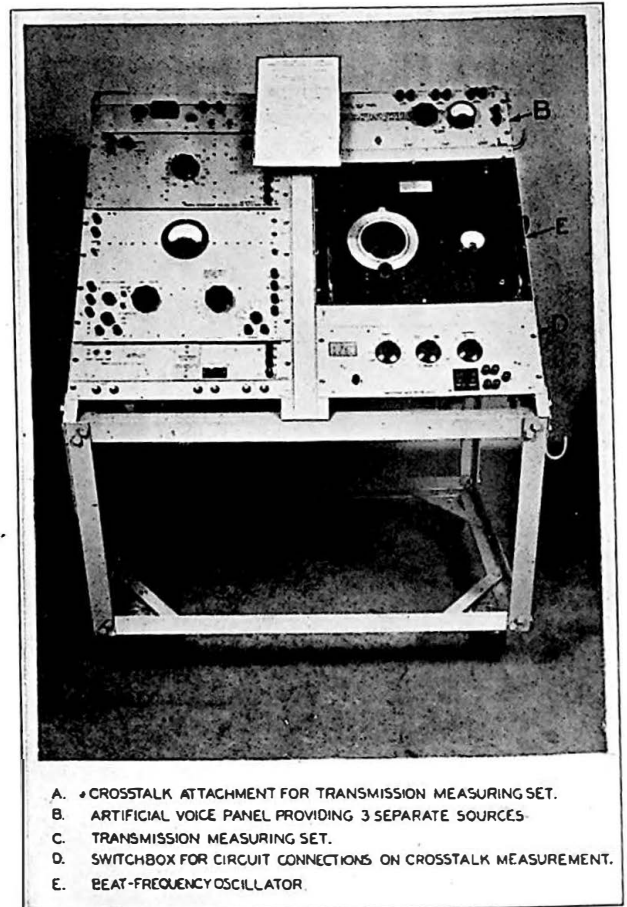

A. CROSSTALK ATTACHMENT FOR TRANSMISSION MEASURING SET.
 B. ARTIFICIAL VOICE PANEL PROVIDING 3 SEPARATE SOURCES.
 C. TRANSMISSION MEASURING SET.
 D. SWITCHBOX FOR CIRCUIT CONNECTIONS ON CROSSTALK MEASUREMENT.
 E. BEAT-FREQUENCY OSCILLATOR.

FIG. 4.—TESTING APPARATUS TROLLEY.

pure source of tone, taking care that correct readings were obtained with input levels at low frequencies.

The behaviour with complex waves was checked in several ways, since in this respect differences were expected.

The summation law of the detectors was checked by applying 900 and 1,100 c/s individually to each instrument, adjusting the inputs to give equal readings and then applying both tones together, and reducing the input of each until the same deflection was obtained.

The dynamic characteristic of each indicating instrument was checked, applying first an overshoot test for damping and secondly an inertia test using a pure tone impulse of 200 mS duration. These two tests are in accordance with the recommendations for instruments used in speech voltmeters and similar to the conditions for the instrument used in the latest volume indicators².

Comparative measurements were made with speech and the artificial voice. When testing with speech, two different types of telephone were used, one a normal local battery instrument and the other a type F field telephone. In all conditions the input

² Proc. I.R.E., Jan. 1940.

speech level was observed on a speech voltmeter and maintained, as far as possible, at constant level, Fig. 5 shows the relation between input and observed output with both measuring instruments, for both types of telephone and for the artificial voice. It

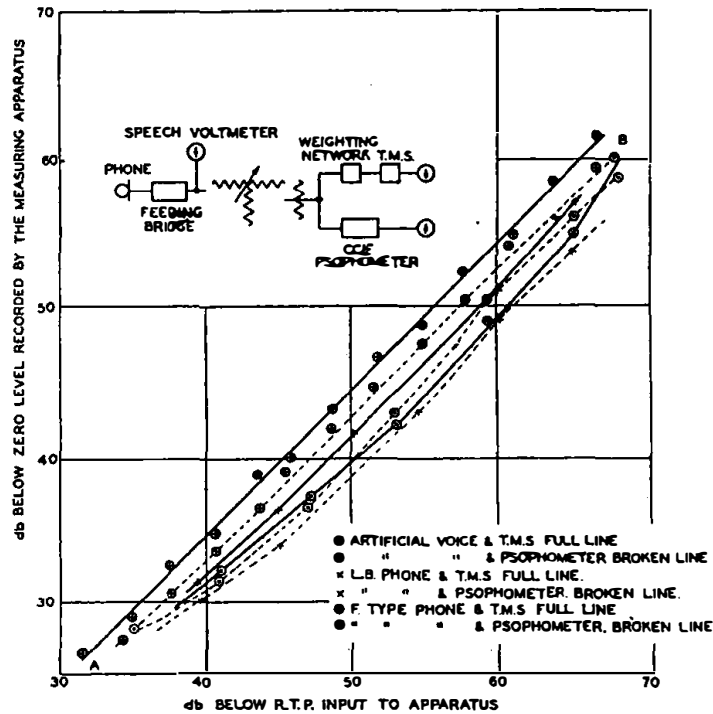

FIG. 5.—INPUT/OUTPUT MEASUREMENTS WITH SPEECH AND ARTIFICIAL VOICE.

will be seen that for all sources, the readings of the psophometer and the T.M.S. differ little and that the artificial voice output agrees fairly well with the F type and LB type telephones. The difficulty of measurements with the human voice as a source of tone is shown by the dispersion of the points on either side of the line, in comparison with the points obtained from the artificial voice source. Errors of some 2 db. arise from the inability of the talker to maintain a constant output from the microphone. The results show a good measure of agreement between the natural and the artificial sources, and between the two types of measuring instrument.

Crosstalk Measurements with Natural and Artificial Voices.

Comparative tests were made on a carrier system, where the crosstalk to be measured as noise consists of a mixture of inverted speech, intermodulation and power supply hum. Two terminal equipments of Apparatus Carrier Telephone (1 + 4) Mark 2 were used for the test. This a four-channel carrier system in which the channels in one direction are obtained by the modulation of carrier frequencies in the range below 16 kc/s; for the opposite direction, the same band is group modulated into the frequency range between 19 and 32 kc/s³.

³ P.O.E.E.J., Vol. 38, p. 1.

The measurements were made with three speakers, natural or artificial, on three carrier channels, with the resulting noise measured on the fourth channel. The input level was -10 db. below R.T.P. in each case, and the noise measured on the weighted T.M.S. in db. below zero level. With all possible combinations of near- and far-end crosstalk with A and B station connections, 32 measurements were made.

Measurements with P.O. 162 type phones and the artificial voice showed that the artificial voice produced consistently greater noise than natural voices, the average difference being 5 db. with a worst case of of 14 db. A plot of the readings is shown in Fig. 6. Such a result is to be expected,

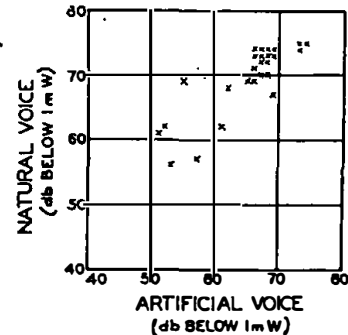

FIG. 6.—COMPARISON OF CROSSTALK VALUES FOR TELEPHONE AND ARTIFICIAL VOICE SOURCES.

since Fig. 2 shows that the artificial voice has a greater response below 1 kc/s than the telephone. A second check was then made with United States Army telephones EE.8.A, which have a better low frequency response than the telephone No. 162, when the average of the 32 readings showed 4 db. more noise from the artificial voice with a worst case of only 7 db.

Conclusions.

The apparatus described has proved of great practical value in production testing, saving much time and labour, and has given consistent results over a period of two years. Although the results obtained are not identical with the standard method of measurement, the error is not large and is consistent. The purpose of the test on production equipment is to show that the noise due to couplings and overloading does not exceed a specified amount. It has been shown that the test applied is somewhat more severe than the normal conditions of voice testing. It is hoped that further investigations to be undertaken when time permits will result in closer agreement between the two methods; when the full benefits of time saving and reproducibility will be realised.

Acknowledgments are due to Messrs. Siemens Brothers & Co., Ltd., for permission to publish the results of work carried out in their laboratories; to Mr. G. H. Foot, who designed the apparatus, and to Mr. W. C. Newman, who carried out the measurements made in connection with the work.

Approximate Formulæ for the Calculation of Attenuation from Open and Closed Impedances

P. R. BRAY, M.Sc. (Eng.), A.M.I.E.E.

U.D.C. 621.317.341

It is normally very tedious to calculate the attenuation of cables from open and closed impedance measurements when the attenuation is more than about 16 db. One difficulty lies in the manner in which the attenuation formulæ, quite rigid in themselves, are expressed. Two such formulæ are discussed, approximate forms being developed from one of them, and reference is made to approximate formulæ of a similar nature already in use.

Introduction.

A CABLE impedance of modulus Z and angle ϕ may be measured by obtaining its equivalent in a bridge circuit with known resistance and reactance components. Since these components have to be varied until the bridge is balanced, it is usual to obtain the reactance with a variable condenser, which is more easily constructed than a variable inductance.

Two basic forms of bridge, with equal ratio arms, are shown in outline in Fig. 1 with the components a) in parallel and (b) in series.

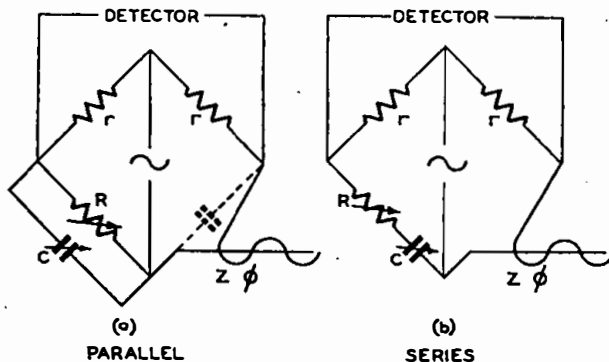

FIG. 1. BASIC FORMS OF A.C. BRIDGE.

A common method of solving the bridges in cable work is first to obtain the angle ϕ by:—

$$(a) \phi = \tan^{-1} \omega CR \text{ (Parallel Bridge)}$$

$$\text{or } (b) \phi = \tan^{-1} \frac{1}{\omega CR} \text{ (Series Bridge)}$$

$$\text{and then } (a) Z = R \cos \phi \text{ or } (b) Z = \frac{R}{\cos \phi}$$

The impedance of the cable is obtained with the far end open-circuited and then short-circuited. This alteration in the far end conditions affects the cable impedance by completely reversing the phase of the reflected waves of current and voltage. The magnitude of the change in impedance is dependent on the magnitudes of these reflected waves when they arrive at the bridge. Since the reflections are attenuated by the cable, the impedance change may be used to measure the cable attenuation.

With the bridges arranged as shown in Fig. 1, the angle ϕ will be negative, since the reactance of a condenser is negative. This is convenient, because a cable impedance normally has a negative angle. Should the reflections from the far end or other irregularities cause the angle of the cable impedance

to become positive, the capacitance in the parallel bridge is connected as shown by the dotted lines in Fig. 1 (a). In the series bridge, the capacitance is placed in series with the line instead of in series with the resistance for positive angles.

The parallel bridge is often to be preferred in cable measurements, because if the cable impedance contains very little reactance (small angle) the capacitance in the series bridge becomes inordinately large unless special arrangements are made by adding capacitance to the other side of the bridge.

It is not possible to describe bridges or bridge methods in detail, and they have been dealt with elsewhere.^{1, 2} It might, however, be mentioned that for balanced circuits (i.e. balanced to earth), at frequencies above 5 kc/s, the "ratio arms" are obtained by balanced transformer windings, and transformers may also be employed for measuring on unbalanced cables (e.g. co-axial).

Normal Attenuation Formulæ.

The vector ratio $\sqrt{Z_c/Z_o}$ gives the value of $\tanh \gamma l$ where Z_c and Z_o are the cable impedances with the far end respectively closed and open. The propagation constant γ is complex, and may be written in the form of $\alpha + j\beta$, the real part α being called the attenuation constant. The quantity αl may be calculated once the value of $\tanh \gamma l$ has been determined in modulus and angle. In the expressions which follow Z_c and Z_o will refer to the modulus of the closed and open impedances, and the respective angles denoted by ϕ_c and ϕ_o . Other symbols used will be those customarily employed in particular formulæ.

An exact equation² extensively employed for attenuation calculation is:—

$$\alpha l = 5 \log_{10} \frac{1 + M + 2\sqrt{M} \cos \mu}{1 + M - 2\sqrt{M} \cos \mu} \text{ db} \dots \dots (1)$$

$$\text{where } M = \frac{Z_c}{Z_o} \text{ and } \mu = \frac{1}{2} (\phi_c - \phi_o)$$

The expression is reasonably convenient for values of αl up to 12 db. using four-figure log tables. For higher values a difficulty is introduced by the form of the denominator. When the electrical length of the cable increases, the closed and open impedances become more nearly equal, and consequently M and \sqrt{M} approach unity. Furthermore, since the values of ϕ_c and ϕ_o converge, μ approaches zero and, there-

¹ B. Hague. "Alternating Current Bridge Methods."

² W. T. Palmer. "Outline Notes on Telephone Transmission Theory."

fore, $\cos \mu$ approaches unity. It then becomes necessary to calculate the small difference $(1 + M) - 2\sqrt{M} \cos \mu$ where both terms are approximately equal to 2. By calculating M and $2\sqrt{M} \cos \mu$ separately, to four significant figures, the small difference may be lost entirely, or at least determined very inaccurately. The use of seven-figure log tables may enable the difference to be found more accurately, but the calculation is correspondingly more tedious.

Equation (1) may be re-arranged in the following way:—

$$\text{Let } \tanh \gamma l = u + jv \quad (= \sqrt{M}/\mu)$$

$$\text{Then } u = \sqrt{M} \cos \mu \text{ and } v = \sqrt{M} \sin \mu$$

$$\begin{aligned} al &= 5 \log_{10} \frac{1 + M + 2\sqrt{M} \cos \mu}{1 + M - 2\sqrt{M} \cos \mu} \text{ db.} \\ &= 5 \log_{10} \frac{1 + (\sqrt{M})^2 1 + 2u}{1 + (\sqrt{M})^2 1 - 2u} \text{ db.} \\ &= 5 \log_{10} \frac{1 + (\sqrt{M})^2 (\cos^2 \mu + \sin^2 \mu) + 2u}{1 + (\sqrt{M})^2 (\cos^2 \mu + \sin^2 \mu) - 2u} \text{ db.} \\ &= 5 \log_{10} \frac{1 + u^2 + v^2 + 2u}{1 + u^2 + v^2 - 2u} \text{ db.} \\ \therefore al &= 5 \log_{10} \frac{(1 + u)^2 + v^2}{(1 - u)^2 + v^2} \text{ db.} \dots \dots \dots (2) \end{aligned}$$

The denominator may now be more easily determined. It is true that arguments against (1) still apply to the term $(1-u)^2$ in equation (2), but the value of v^2 , which is normally a significant part of the denominator as u approaches unity, is now calculated directly and not as the difference of two much larger quantities.

$$v^2 = \frac{Z_c}{Z_i} \sin^2 \frac{\phi_c - \phi_i}{2} \text{ and for high attenuations,}$$

where Z_c is nearly equal to Z_i , the value of the sine is the important term in the product, with $\frac{\phi_c - \phi_i}{2}$

a fairly small angle of a few degrees or less. In evaluating v^2 , therefore, a table of logarithms of sines of small arcs is useful, as it saves interpolation in the part of the main log sin. table, where mean differences are larger and inaccurate. For values of $\frac{\phi_c - \phi_i}{2}$ up to 6° $\sin \frac{\phi_c - \phi_i}{2}$ may be replaced by the value of the angle in radians. This saves a considerable amount of labour and there is no sensible loss of accuracy. 6° is equal to 0.1047 radians and $\sin 6^\circ = 0.1045$.

Equation (2) may be used with four-figure tables up to attenuations of 30 db. At this stage the accuracy is variable, depending on how much the difference of the open and closed impedance is in the angle. In the particular case where the impedance differences make $u=1$, the denominator is most easily calculated, as v^2 is then the only term in it.

Introduction of Bridge Differences into an Exact Formula (Parallel Bridge).

It has already been pointed out that differences between open and closed impedances may be obtained reasonably accurately, and then thrown away as it were by the application of an unsuitable formula.

In this type of cable measurement differences are of primary importance, and a certain amount of error is tolerable in the impedance measurements provided it is common to both the open and closed cases. It is thus possible to make accurate measurements of attenuation by the open and closed method even though the differences of capacitance and resistance involved may be quite small compared with even the residuals of the components used, provided the measured differences may be utilised directly.

The formula which is derived below is not intended to be in any sense a short cut, but merely an exact expression for al which may be calculated by four-figure logarithms or a slide rule with no limitations whatsoever.

Considering equation (1), it has been seen that the form of denominator leads to difficulties at the higher attenuations. The difficulty may be resolved as follows:—

$$\begin{aligned} al &= 5 \log_{10} \frac{1 + M + 2\sqrt{M} \cos \mu}{1 + M - 2\sqrt{M} \cos \mu} \text{ db.} \\ &= 5 \log_{10} \frac{1 + M + 2\sqrt{M} \cos \mu}{1 + M - 2\sqrt{M} \cos \mu} \cdot \frac{1 + M + 2\sqrt{M} \cos \mu}{1 + M + 2\sqrt{M} \cos \mu} \text{ db.} \\ &= 5 \log_{10} \frac{(1 + M + 2\sqrt{M} \cos \mu)^2}{(1 + M)^2 - 4M \cos^2 \mu} \text{ db.} \dots \dots \dots (3) \end{aligned}$$

The denominator is now

$$\begin{aligned} &(1 + M)^2 - 4M \left(\frac{1 + \cos 2\mu}{2} \right) \\ &= \left(1 + \frac{Z_c}{Z_i} \right)^2 - 2 \frac{Z_c}{Z_i} (1 + \cos [\phi_c - \phi_i]) \\ &= 1 + 2 \frac{Z_c}{Z_i} + \left(\frac{Z_c}{Z_i} \right)^2 - 2 \frac{Z_c}{Z_i} - \\ &\qquad\qquad\qquad 2 \frac{Z_c}{Z_i} (\cos \phi_c \cos \phi_i + \sin \phi_c \sin \phi_i) \\ &= \frac{1}{Z_i^2} (Z_i^2 + Z_c^2) - \\ &\qquad\qquad\qquad 2 \frac{Z_c}{Z_i} (\cos \phi_c \cos \phi_i + \sin \phi_c \sin \phi_i) \dots \dots (4) \end{aligned}$$

Let R_c , C_c , and R_i , C_i be the parallel bridge resistance and capacitance readings (in ohms and farads) for the closed and open impedances respectively, at a frequency f cycles per second.

$$\text{The bridge differences may be written as}$$

$$\delta R = R_c - R_i, \quad \delta C = C_c - C_i$$

It will also be convenient to write $R_c^2 = R_c R_i$ and $C_c^2 = C_c C_i$.

The suffix g signifies geometric mean, but in the case of the capacitance it should be noted that since C_c and C_i must always carry their appropriate bridge signs, C_g^2 might on occasions be negative.

$$\begin{aligned} &\text{Since } (R_c - R_i)^2 = \delta R^2 \\ &\text{Then } R_c^2 + R_i^2 - 2R_c R_i = \delta R^2 \\ &\qquad\qquad\qquad \therefore R_c^2 + R_i^2 = \delta R^2 + 2R_g^2 \\ &\text{Similarly } C_c^2 + C_i^2 = \delta C^2 + 2C_g^2 \end{aligned}$$

Reverting now to expression (4):

$$\begin{aligned} &\frac{1}{Z_i^2} (Z_i^2 + Z_c^2) - 2 \frac{Z_c}{Z_i} (\cos \phi_c \cos \phi_i + \sin \phi_c \sin \phi_i) \\ &= \frac{1}{R_i^2 \cos^2 \phi_i} (R_i^2 \cos^2 \phi_i + R_c^2 \cos^2 \phi_i) - \\ &\qquad\qquad\qquad 2 \frac{R_c \cos \phi_c}{R_i \cos \phi_i} (\cos \phi_c \cos \phi_i + \sin \phi_c \sin \phi_i) \end{aligned}$$

$$\begin{aligned}
&= \frac{(1+\omega^2 R_i^2 C_i^2)}{R_i^2} \left(\frac{R_i^2}{1+\omega^2 R_i^2 C_i^2} + \frac{R_c^2}{1+\omega^2 R_c^2 C_c^2} \right) - \\
&\quad 2 \frac{R_c}{R_i} \cos^2 \phi_c + \cos \phi_c \sin \phi_c \tan \phi_i \\
&= \frac{1}{R_i^2 (1+\omega^2 R_c^2 C_c^2)} (R_i^2 [1+\omega^2 R_c^2 C_c^2] + \\
&\quad R_c^2 [1+\omega^2 R_i^2 C_i^2]) - \frac{2 R_c \cos^2 \phi_c}{R_i} (1 + \tan \phi_c \tan \phi_i) \\
&= \frac{1}{R_i^2 (1+\omega^2 R_c^2 C_c^2)} (R_i^2 + R_c^2 + \omega^2 R_i^2 R_c^2 [C_i^2 + C_c^2]) \\
&\quad - \frac{2 R_c}{R_i (1+\omega^2 R_c^2 C_c^2)} (1 + \omega^2 R_i R_c C_i C_c) \\
&= \frac{1}{R_i^2 (1+\omega^2 R_c^2 C_c^2)} (\delta R^2 + 2 R_c^2 + \omega^2 R_c^4 [\delta C^2 + 2 \cdot C_c^2]) \\
&\quad - \frac{2}{R_i (1+\omega^2 R_c^2 C_c^2)} (R_c^2 + \omega^2 R_c^4 C_c^2) \\
&= \frac{1}{R_i^2 (1+\omega^2 R_c^2 C_c^2)} (\delta R^2 + \omega^2 \delta C^2 R_c^4) \dots \dots \dots (5)
\end{aligned}$$

The denominator has thus been reduced to a number of terms, each of which is positive, and it is directly dependent on the measured bridge differences. Inserting expression (5) in equation (3) gives

$$\alpha l = 5 \log_{10} \frac{R_i^2 (1 + \omega^2 R_c^2 C_c^2) (1 + M + 2\sqrt{M} \cos \mu)^2}{\delta R^2 + \omega^2 \delta C^2 R_c^4} \text{ db.}$$

which leads to

$$\alpha l = 5 \log_{10} \frac{Z_i + Z_c + 2Z_o \cos \mu}{(\delta R^2 + \omega^2 \delta C^2 R_c^4) \cos^2 \phi_c \cos^2 \phi_i} \text{ db.} \dots (6)$$

where Z_o is the characteristic impedance ($= \sqrt{Z_i Z_c}$).

Equation (6) has only a limited application in practice. Up to 12 db. or so an equation of the form given by (1) is adequate, and for higher attenuations one or other of the approximate formulæ to follow would probably suffice. It will be shown that when the angles of the impedances are of the order of ten degrees or less, great simplifications are possible, covering cables of long electrical length at frequencies above 10 kc/s.

At lower frequencies, when the cable is sufficiently long to have high attenuation but the angles are rather large, the following modification might be useful :-

Approximate Attenuation Formula of Known Error.

From equation (1)

$$\begin{aligned}
\alpha l &= 5 \log_{10} \frac{1 + M - 2\sqrt{M} \cos \mu + 4\sqrt{M} \cos \mu}{1 + M - 2\sqrt{M} \cos \mu} \text{ db.} \\
&= 5 \log_{10} \left(\frac{4\sqrt{M} \cos \mu}{1 + M - 2\sqrt{M} \cos \mu} + 1 \right) \text{ db.} \\
&= 5 \log_{10} N \text{ db. (say).}
\end{aligned}$$

$$\text{Then } \frac{4\sqrt{M} \cos \mu}{1 + M - 2\sqrt{M} \cos \mu} = N - 1$$

$$\begin{aligned}
\text{and } \alpha l &= 5 \log_{10} \frac{N}{N-1} \cdot \frac{4\sqrt{M} \cos \mu}{1 + M - 2\sqrt{M} \cos \mu} \text{ db.} \\
&= 5 \log_{10} \frac{N}{N-1} + 5 \log_{10} \frac{4\sqrt{M} \cos \mu}{1 + M - 2\sqrt{M} \cos \mu}
\end{aligned}$$

$$\begin{aligned}
&= 5 \log_{10} \frac{N}{N-1} + 5 \log_{10} \frac{4\sqrt{M} \cos \mu}{1 + M + 2\sqrt{M} \cos \mu} \times \\
&\quad \frac{1 + M + 2\sqrt{M} \cos \mu}{1 + M - 2\sqrt{M} \cos \mu} \\
&= 5 \log_{10} \frac{N}{N-1} + 5 \log_{10} \frac{4\sqrt{M} \cos \mu}{1 + M + 2\sqrt{M} \cos \mu} \times \\
&\quad \frac{N}{N-1} \cdot \frac{4\sqrt{M} \cos \mu}{1 + M - 2\sqrt{M} \cos \mu} \\
&= 5 \log_{10} \left(\frac{N}{N-1} \right)^2 + \\
&\quad 5 \log_{10} \frac{16 M \cos^2 \mu}{(1 + M + 2\sqrt{M} \cos \mu) (1 + M - 2\sqrt{M} \cos \mu)} \\
&= 5 \log_{10} \left(\frac{N}{N-1} \right)^2 + 5 \log_{10} \frac{R_i^2 \cdot 16 \frac{R_c \cos \phi_c}{R_i \cos \phi_i} \cdot \cos^2 \mu}{\cos^2 \phi_c (\delta R^2 + \omega^2 \delta C^2 R_c^4)} \\
&= 5 \log_{10} \left(\frac{N}{N-1} \right)^2 + \\
&\quad 5 \log_{10} \frac{16 R_i^2 \cdot \cos^2 \mu}{(\delta R^2 + \omega^2 \delta C^2 R_c^4) \cos \phi_c \cos \mu_i} \text{ db.} \dots \dots \dots (7)
\end{aligned}$$

Any required degree of accuracy may be obtained with equation (7) and it is in a suitable form for logarithmic calculation, being made up chiefly of products. It is necessary to obtain the angles ϕ_c , ϕ_i and hence μ from the bridge readings. The

correction term $5 \log_{10} \left(\frac{N}{N-1} \right)^2$ has been evaluated, and is tabulated below in terms of the attenuation as calculated from the expression

$$5 \log_{10} \frac{16 R_i^2 \cos^2 \mu}{(\delta R^2 + \omega^2 \delta C^2 R_c^4) \cos \phi_c \cos \phi_i} \text{ in equation (7).}$$

Calculated Attenuation db.	Correction Add db.	Calculated Attenuation db.	Correction Add db.
6.000	0.250	10.000	0.043
6.500	0.203	12.000	0.017
7.000	0.163	14.000	0.007
8.000	0.105	16.000	0.002
9.000	0.067	18.000	0.001

The table shows how rapidly the correction required decreases as the calculated attenuation becomes larger, and is less than 0.1 per cent. at 13 db. and above.

Further Approximations.

Neglecting the correction in (7)

$$\alpha l \approx 5 \log_{10} \frac{16 R_i^2 \cdot \cos^2 \mu}{(\delta R^2 + \omega^2 \delta C^2 \cdot R_c^4) \cos \phi_c \cos \phi_i} \text{ db.}$$

Since $\mu = \frac{\phi_c - \phi_i}{2}$ and ϕ_o (angle of Z_o) = $\frac{\phi_c + \phi_i}{2}$, the

$$\begin{aligned}
\text{term } \frac{\cos^2 \mu}{\cos \phi_c \cos \phi_i} &= \frac{\cos^2 \mu}{\cos (\phi_o + \mu) \cos (\phi_o - \mu)} \\
&= \frac{\cos^2 \mu}{(\cos \phi_o \cos \mu - \sin \phi_o \sin \mu) (\cos \phi_o \cos \mu + \sin \phi_o \sin \mu)} \\
&= \frac{\cos^2 \mu}{\cos^2 \phi_o \cos^2 \mu - \sin^2 \phi_o \sin^2 \mu} \\
&= \frac{1}{\cos^2 \phi_o - \sin^2 \phi_o \cdot \tan^2 \mu}
\end{aligned}$$

The angle ϕ_0 has a limiting value of 45° (at an indefinitely low frequency). Its magnitude between this limit and zero is dependent only on the type of cable and the frequency. μ on the other hand depends on the difference between the angles of the open and closed impedances. As the attenuation value increases this difference becomes small, and $\tan^2 \mu$ is then quite small. Above 10 db. μ will normally be less than 8° (usually very much less) and $\tan^2 8^\circ = 0.0198$. This figure is considerably reduced when multiplied by $\sin^2 \phi_0$, the maximum value of which is 0.500. Since the *minimum* value of $\cos^2 \phi_0$ is 0.500, $\sin^2 \phi_0 \cdot \tan^2 \mu$ may thus be neglected in comparison with $\cos^2 \phi_0$ at attenuations above 10 db., except possibly at very low frequencies as ϕ_0 approaches 45° . This possibility is not of frequent occurrence in telephone practice because a circuit of long electrical length at such a low frequency would have a very restricted use.

The fraction $\frac{\sin^2 \phi_0 \cdot \tan^2 \mu}{\cos^2 \phi_0}$ is equal to $\tan^2 \phi_0 \cdot \tan^2 \mu \times 100$ per cent.

The db. error for various values of this fraction when it is neglected is as follows:—4 per cent. = 0.085 db., 3 per cent. = 0.064 db., 2 per cent. = 0.043 db., 1 per cent. = 0.022 db.

Equation (7) then reduces to the approximate form

$$al \approx 5 \log_{10} \frac{16 \cdot R_c^2}{\cos^2 \phi_0 (\delta R^2 + \omega^2 \delta C^2 R_c^4)} \text{ db.} \dots \dots (8)$$

For 12-circuit carrier, balanced pair, and co-axial cables in the working band of frequencies, it is usually found that ϕ_0 is quite small, and $\cos^2 \phi_0$ approaches unity. The final approximation is then

$$al \approx 5 \log_{10} \frac{16 \cdot R_c^2}{\delta R^2 + \omega^2 \delta C^2 \cdot R_c^4} \text{ db.} \dots \dots (9)$$

This will be found to be adequate for the types of cables mentioned at their normal working frequencies and attenuation lengths above 10 db. It might be noted that as δR and δC become small, it is unlikely that they would be determined extremely accurately, except under laboratory conditions, and for field use the degree of approximation in equation (9) is not then unduly severe.

With $\phi_0 = 8^\circ$, the error in writing $\cos^2 \phi_0 = 1$ is 2 per cent., i.e. 0.043 db.

When it is necessary to include the value of $\cos^2 \phi_0$ as in equation (8), then it may normally be assumed that ϕ_0 (the algebraic mean of ϕ_c and ϕ_l) is given by $\tan \phi_0 \approx \omega C_m R_c$ where the suffix m indicates the algebraic mean of the capacitance readings. Then

$$\frac{1}{\cos^2 \phi_0} \approx 1 + \omega^2 \cdot C_m^2 \cdot R_c^2$$

Considering equation (9), two special cases merit attention. If the frequency of test can be suitably selected, it may be arranged that the capacitance does not change when the far end of the cable is open or closed.

Then $\delta C = 0$, and

$$al \approx 5 \log_{10} \frac{16 R_c^2}{\delta R^2} \text{ db.}$$

$$= 10 \log_{10} \frac{4 R_c}{\delta R} \text{ db.} \dots \dots (10)$$

Similarly, if the frequency is such that the resistance reading is unchanged

$$al \approx 10 \log_{10} \frac{4}{\omega \cdot \delta C \cdot R} \text{ db.} \dots \dots (11)$$

where R is the constant resistance.

The conditions under which equation (11) applies are probably the more practicable, as it is easier to construct a variable air condenser having small change of resistance, than it is a variable resistance having a small change of reactance, especially at high frequencies. It will also be noticed that the absolute value of reactance does not appear in the equation. The simplification $\delta R = 0$ or $\delta C = 0$ may, of course, be used when applicable to equations (6), (7) and (8).

References.

An equation due to K. E. Latimer and A. L. Meyers³ is

$$al \approx 10 \log_{10} \frac{4 R_m \sqrt{1 + \omega^2 C_m^2 R_m^2}}{(\delta R^2 + \omega^2 \delta C^2 R_m^4)} \text{ db.} \dots (12)$$

where m signifies the mean of the open and closed parallel bridge readings. Although this equation has been in use for some time, it is believed that it has not previously been published. Equation (8) of the present article corresponds very closely, and represents about the same degree of approximation.

An alternative approach to that adopted here is to work in terms of the hyperbolic tangent

$$\tanh \psi l = \frac{e^{\psi l} - e^{-\psi l}}{e^{\psi l} + e^{-\psi l}}$$

and approximate for the modulus of $e^{\psi l}$ at a suitable stage. This leads to the rather neat approximation⁴

$$al \approx 10 \log_{10} \frac{4 Z_0}{\delta Z} \text{ db.} \dots \dots (13)$$

where Z_0 is the modulus of the characteristic impedance and δZ is the modulus of the vector difference between the open and closed impedances. This equation is not itself in terms of bridge readings, but is readily convertible for use with either a series or parallel bridge. In the latter case, it leads to a solution of the form given by equation (9).

Reference must also be made to the work of Dr. A. Rosen, who has developed some convenient and well-tried formulæ in this field.⁵

Conclusion.

The uses and limitations of "open and closed" attenuation formulæ have been discussed, and bridge readings directly introduced in order to increase the accuracy of calculation. Where approximate forms are developed, it is found that the later stages successively correspond closely to those due to previous contributors to the subject. Equations using series bridge readings could be similarly deduced, but this has not been done here, as a simple series bridge is not suitable for accurate measurements on cables of small angle.

³ T.C. & M. Co., Ltd.

⁴ E. W. Smith. *Journal I.E.E.*, Vol. 73, p. 213.

⁵ A. Rosen. *Journal I.E.E.*, Vol. 68, p. 499.

Notes and Comments

Roll of Honour

The Board of Editors deeply regrets to have to record the deaths of the following members of the Engineering Department :—

While serving with the Armed Forces or on Post Office Duty.

Belfast Telephone Area ..	Kelly, J. ..	Unestablished Skilled Workman	Sergeant, Royal Signals
Birmingham Telephone Area	Thould, J. ..	Skilled Workman, Class II ..	Pilot Officer, R.A.F.
Birmingham Telephone Area	Hanson, L. P. ..	Skilled Workman, Class II ..	Signalman, Royal Signals
Birmingham Telephone Area	Winsper, L. ..	Skilled Workman, Class II ..	Staff Sergeant, A.A.C.
Bradford Telephone Area ..	Berrisford, M. W.	Skilled Workman, Class II ..	Signalman, Royal Signals
Brighton Telephone Area ..	Dyer, W. A. ..	Unestablished Skilled Workman	Sergeant Navigator, R.A.F.
Bristol Telephone Area ..	Walker, J. D. ..	Skilled Workman, Class II ..	Pilot Officer, R.A.F.
Bristol Telephone Area ..	Wardrapper, J. D.	Skilled Workman, Class II ..	Lance Corporal, Royal Signals
Cambridge Telephone Area	Jones, E. S. ..	Unestablished Draughtsman ..	Flight Sergeant, R.A.F.
Colchester Telephone Area	Judd, J. F. ..	Skilled Workman, Class II ..	Flying Officer, R.A.F.
Colchester Telephone Area ..	Whale, H. E. ..	Skilled Workman, Class II ..	Flight Sergeant, R.A.F.
Dundee Telephone Area ..	Streatfield, A. ..	Unestablished Skilled Workman	Sergeant Pilot, R.A.F.
Edinburgh Telephone Area..	Fishbourne, R. D.	Unestablished Skilled Workman	Flight Sergeant, R.A.F.
Edinburgh Telephone Area..	Younger, J. W. ..	Unestablished Skilled Workman	Captain, Deccan Horse
Engineering Department ..	Arthur, L. J. ..	Unestablished Skilled Workman	Sergeant, R.A.F.
Engineering Department ..	Grigsby, G. W.	Chief Cook	On Post Office Duty
Engineering Department ..	McCallum, D. A.	Leading Stoker	On Post Office Duty
Engineering Department ..	Richardson, F. J.	Unestablished Skilled Workman	Sergeant Pilot, R.A.F.
Engineering Department ..	Silverman, A. L.	Clerical Officer	Flight Lieutenant, R.A.F.
Engineering Department ..	Squires, F. W. ..	Inspector	Lieutenant, R.N.V.R.
Engineering Department ..	Thomas, R. J. ..	Unestablished Skilled Workman	Flight Sergeant, R.A.F.
Engineering Department ..	Thornburrow, W.	Fourth Engineer	On Post Office Duty
Glasgow Telephone Area ..	Blackie, C. M. ..	Labourer.. .. .	Corporal, Highland Light Infantry
Glasgow Telephone Area ..	McFadyen, J. M.	Skilled Workman, Class II ..	Lance Corporal, Royal Signals
Gloucester Telephone Area..	Bray, D. ..	Unestablished Skilled Workman	Pilot Officer, R.A.F.
Leeds Telephone Area ..	Tatham, K. R. ..	Skilled Workman, Class II ..	Pilot Officer, R.A.F.
Liverpool Telephone Area..	Baker, W. S. ..	Unestablished Skilled Workman	Flight Lieutenant, R.A.F.
Liverpool Telephone Area ..	Blythe, W. J. ..	Skilled Workman, Class II ..	Lance Corporal, Royal Signals
Liverpool Telephone Area..	Jackson, F. ..	Unestablished Skilled Workman	Aircraftman, Class II, R.A.F.
London Telecommunications Region	Ansell, F. N. ..	Skilled Workman, Class II ..	Sergeant, Royal Air Force
London Telecommunications Region	Ball, D. A. J. W.	Skilled Workman, Class II ..	Flying Officer, R.A.F.
London Telecommunications Region	Benton, D. ..	Skilled Workman, Class II ..	Lieutenant, Royal Signals
London Telecommunications Region	Brodby, J. R. ..	Unestablished Skilled Workman	Flying Officer, R.A.F.
London Telecommunications Region	Cooke, L. A. ..	Unestablished Skilled Workman	Sergeant, R.A.F.
London Telecommunications Region	Ellerker, L. H. ..	Skilled Workman, Class II ..	Flying Officer, R.A.F.
London Telecommunications Region	Hosier, F. ..	Unestablished Skilled Workman	Flying Officer, R.A.F.
London Telecommunications Region	Marshall, W.C. ..	Skilled Workman, Class II ..	Trooper, Staffordshire Yeomanry
London Telecommunications Region	Noyes, P. R. ..	Unestablished Skilled Workman	Pilot Officer, R.A.F.
London Telecommunications Region	Potter, R. G. ..	Unestablished Skilled Workman	Sergeant, R.A.F.
London Telecommunications Region	Pursell, S.H. ..	Skilled Workman, Class II ..	Signalman, Royal Signals

London Telecommunications Region	Roads, G. H. . .	Unestablished Skilled Workman	Aircraftman, Class II, R.A.F.
London Telecommunications Region	Shepherd, P. A. . .	Unestablished Skilled Workman	Flight Sergeant, R.A.F.
London Telecommunications Region	Thomas, K. V. . .	Skilled Workman, Class II	Warrant Officer, R.A.F.
Newcastle - on - Tyne Telephone Area	Cusworth, F. H.	Unestablished Skilled Workman	Flying Officer, R.A.F.
Norwich Telephone Area	Foster, A. J. . .	Skilled Workman, Class II	Flight Sergeant, R.A.F.
Oxford Telephone Area	Greening, L. T. . .	Skilled Workman, Class II	Signalman, Royal Signals
Portsmouth Telephone Area	Elliott, G. H. . .	Skilled Workman, Class II	Flight Sergeant, R.A.F.
Portsmouth Telephone Area	Mumford, M. S. G.	Unestablished Skilled Workman	Flight Sergeant, R.A.F.
Preston Telephone Area	Clement, C. R. . .	Skilled Workman, Class II	Flight Sergeant, R.A.F.
Preston Telephone Area	Hunter, E. . .	Skilled Workman, Class II	Signalman, Royal Signals
Preston Telephone Area	Roach, W. . .	Skilled Workman, Class II	Gunner, Royal Artillery
Reading Telephone Area	Dunstone, F. V. J.	Skilled Workman, Class II	Sergeant, R.A.F.
Reading Telephone Area	Jones, R. R. . .	Skilled Workman, Class II	Flight Sergeant, R.A.F.
Sheffield Telephone Area	Cadman, J. . .	Skilled Workman, Class II	Private, Royal Army Ordnance Corps
Sheffield Telephone Area	Green, B. G. . .	Unestablished Skilled Workman	Flight Sergeant, R.A.F.
Sheffield Telephone Area	Heenan, J. P. . .	Chief Inspector	Lieutenant, Royal Signals
Taunton Telephone Area	Evans, E. J. . .	Unestablished Skilled Workman	Corporal, R.A.F.
Tunbridge Wells Telephone Area	Elkington, G. F.	Skilled Workman, Class I	Flying Officer, R.A.F.

Recent Awards

The Board of Editors has learnt with great pleasure of the honours recently conferred on the following members of the Engineering Department :—

While serving with the Armed Forces, including the Home Guard, or on Post Office Duty.

Aberdeen Telephone Area	Duguid, R. M. . .	Skilled Workman, Class II	Corporal, Royal Signals	American Bronze Star
Belfast Telephone Area	Butten, J. T. . .	Skilled Workman, Class I	Corporal, R.A.F.	Mentioned in Despatches
Belfast Telephone Area	O'Brien, E., D.F.M.	Unestablished Skilled Workman	Flying Officer, R.A.F.	Distinguished Flying Cross
Belfast Telephone Area	O'Brien, E., D.F.C., D.F.M.	Unestablished Skilled Workman	Flying Officer, R.A.F.	Distinguished Service Order
Belfast Telephone Area	Waite, D. . .	Assistant Engineer	Major, Royal Signals	Member of the Order of the British Empire
Birmingham Telephone Area	Morvan, C. A. . .	Unestablished Skilled Workman	Air Fitter (L), Fleet Air Arm	British Empire Medal
Blackburn Telephone Area	Laycock, E. F. . .	Unestablished Skilled Workman	Signalman, Royal Signals	Military Medal
Blackburn Telephone Area	Pilkington, H. . .	Unestablished Skilled Workman	Flying Officer, R.A.F.	Distinguished Flying Cross
Blackburn Telephone Area	Stott, J. . .	Skilled Workman, Class II	Lieut., Royal Signals	Member of the Order of the British Empire and Mentioned in Despatches
Canterbury Telephone Area	Chilton, C. C. H.	Inspector	On Post Office Duty	Commended by H.M. the King
Canterbury Telephone Area	Cornford, R. J. P.	Skilled Workman, Class I	On Post Office Duty	Commended by H.M. the King
Canterbury Telephone Area	Pritchard, D.W.G.	Unestablished Skilled Workman	On Post Office Duty	Commended by H.M. the King
Canterbury Telephone Area	Scutt, R. S. . .	Chief Inspector	On Post Office Duty	British Empire Medal
Cardiff Telephone Area	Rymer, N. B. . .	Inspector	Major, Royal Signals	Member of the Order of the British Empire

Chester Telephone Area	.. Mullinex, H. J. . .	Skilled Workman, Class II	Sergeant, Royal Signals	Mentioned in Despatches
Colchester Telephone Area	.. Downes, T. J., M.M.	Skilled Workman, Class I	Sergeant, Home Guard	British Empire Medal
Edinburgh Telephone Area	Burgess, J. A. . .	Skilled Workman, Class II	Flight Lieut., R.A.F.	Distinguished Flying Cross
Edinburgh Telephone Area	Christie, G. N.	Skilled Workman, Class II	Lance Corporal, Royal Signals	Military Medal
Engineering Department	.. Freestone, A. G., M.M.	Assistant Engineer	Major, Royal Signals	Member of the Order of the British Empire
Engineering Department	.. Hawthorne, A. D.	Skilled Workman, Class I	On Post Office Duty	Commended by H.M. the King
Engineering Department	.. Holmes, N. P. . .	Unestablished Skilled Workman	Flying Officer, R.A.F.	Distinguished Flying Cross
Engineering Department	.. McMillan, D. . .	Executive Engineer	Lieut.-Col., Royal Signals	Mentioned in Despatches
Engineering Department	.. North, H. E. . .	Mechanic	.. A.Q.M.S., North Sherwood Rangers Yeomanry	Mentioned in Despatches
Engineering Department	.. Organ, E. C. H.	Inspector	.. Lieut.-Col., Royal Signals	Member of the Order of the British Empire and Mentioned in Despatches
Engineering Department	.. Saxby, F. H. . .	Inspector	.. Major, Royal Signals	Mentioned in Despatches
Engineering Department	.. Smith, H. G. F.	Clerical Officer	.. C.Q.M.S., Royal Signals	British Empire Medal
Guildford Telephone Area	.. Claydon, G. H.	Skilled Workman, Class II	Lieut., Royal Signals	Croix de Guerre
Guildford Telephone Area	.. Hawkins, H. . .	Skilled Workman, Class I	Lieut., Royal Navy	Distinguished Service Cross
Home Counties Region	.. Ireland, J. C. . .	Assistant Engineer	Major, Royal Signals	Member of the Order of the British Empire
Lincoln Telephone Area	.. Taylor, A. E. . .	Unestablished Skilled Workman	Flying Officer, R.A.F.	Distinguished Flying Cross
London Telecommunications Region	Finch, D. G. . .	Unestablished Skilled Workman	Sergeant (Fl. Engr.), R.A.F.	Distinguished Flying Medal
London Telecommunications Region	Meed, R. H., D.S.C.	Unestablished Skilled Workman	Sub-Lieut., R.N.V.R.	Bar to Distin- guished Service Cross
London Telecommunications Region	Spelling, J. W.	Skilled Workman, Class II	Sergeant, Royal Signals	British Empire Medal
London Telecommunications Region	Vinn, J. M. . .	Skilled Workman, Class I	Sergeant, Royal Signals	British Empire Medal
London Telecommunications Region	Wood, C. J. . .	Skilled Workman, Class I	Sergeant, Royal Signals	Mentioned in Despatches
Manchester Telephone Area	Hall, H. . .	Skilled Workman, Class II	Petty Officer, R.N.	Mentioned in Despatches
Northern Ireland Region	.. Gates, N. P. . .	Inspector	.. Captain, Royal Signals	Member of the Order of the British Empire and Mentioned in Despatches
North-Western Region	.. Hough, F. A., M.B.E.	Executive Engineer	Lieut.-Col. Royal Signals	Mentioned in Despatches
North-Western Region	.. Truman, G. F.	Assistant Engineer	Captain, Royal Signals	Mentioned in Despatches
Norwich Telephone Area	.. Batch, G. B.*	Chief Inspector	.. Major, Home Guard	Member of the Order of the British Empire

* Shown incorrectly in the April, 1945, issue as Ball, H. J.

Norwich Telephone Area	.. Duckett, A. E. . .	Labourer . . .	Sergeant, R.A.C. . .	Military Medal
Norwich Telephone Area	.. Weston, F. . .	Skilled Workman, Class II	Signalman, Royal Signals	Croix de Guerre
Nottingham Telephone Area	Randal, S. E. . .	Skilled Workman, Class II	Lance Corporal, Royal Signals	Mentioned in Despatches
Oxford Telephone Area	.. Benfield, J. A. . .	Skilled Workman, Class II	Signalman, Royal Signals	Mentioned in Despatches
Scotland West Telephone Area	Adam, W. S. . .	Skilled Workman, Class II	Sergeant, Royal Signals	British Empire Medal
Scottish Region	.. Hall, G. K. . .	Assistant Engineer	Lieut.-Col., Royal Signals	Officer of the Order of the British Empire
Sheffield Telephone Area	.. Brewer, J. R. . .	Skilled Workman, Class II	Flying Officer, R.A.F.	Distinguished Flying Cross
South-Western Region	.. Baines, J. . .	Regional Engineer	Lieut.-Col., Royal Signals	Officer of the Order of the British Empire
Swansea Telephone Area	.. Manning, D. J.	Skilled Workman, Class II	Flight.-Lieut. R.A.F.	Distinguished Flying Cross

Birthday Honours

Apart from Post Office personnel whose awards are recorded above, we were pleased to note that the following members of the telecommunications industry were honoured in the Birthday Honours List.

Knight Commander of the Order of the British Empire.

Mr. T. A. Eades, Managing Director, Automatic Telephone and Electric Co., Ltd.

Officers of the Order of the British Empire.

Mr. O. E. Brenner, Works Director, Creed & Co., Ltd.

Mr. F. T. Jackson, Managing Director, Telephone Manufacturing Company.

Mr. A. W. Montgomery, Technical Director, Standard Telephones and Cables, Ltd.

Mr. G. Riley, Telephone Sales Manager, General Electric Co., Ltd.

Members of the Order of the British Empire.

Mr. H. E. Humphries, Telecommunications Department Manager, Siemens Bros. & Co., Ltd.

Mr. S. E. Kirk, Assistant Works Manager, Creed & Co., Ltd.

Regional Notes

London Telecommunications Region

ELGAR AUTOMATIC EXCHANGE

Elgar exchange was opened on Thursday, May 10th, 1945, when approximately 1,800 subscribers' lines were transferred satisfactorily from Willesden manual exchange. The majority of these subscribers were previously working hypothetically on Willesden.

The contract for 2000-type linefinder equipment was placed with the General Electric Company in 1938, but was amended later and uni-selectors substituted for linefinders. On the outbreak of war, it was decided to continue manufacture of the equipment but to store it on site for possible emergencies. In due course, these arose and the main distribution frame consisting of 47 verticals together with the associated fuse mountings and protectors were utilised to form part of the new frame erected at Wood Street building to replace the frame which was lost together with all the automatic equipment, due to enemy action. In addition, all group selectors, banks and racks were used for the conversion of Toll "A" to automatic working. Subsequently, all this equipment was replaced and installation commenced in November, 1943, and completed in March, 1945.

The automatic equipment has a capacity of 3,800 lines initially and 5,400 ultimately. The batteries are plated to a capacity of 1,200 Ah. and have a box capacity of

1,650 Ah. They were installed by the D.P. Battery Co., Ltd. The manual board is at Ladbroke. The numbers of junctions involved at the transfer were 265 outgoing and 314 incoming together with 94 circuits to and from the Ladbroke manual board.
G.A.A.
F.J.W.

LONG-DISTANCE CONTROL GROUP

A heavy programme has been set the Long Distance Telephone Area for 1945-46 to provide new trunk and toll circuits. The extent of the work will be appreciated from the following figures extracted from Headquarters Circular C 78/44. (These figures exclude routes under 25 miles.)

	Existing 1.8.44	Required on Demand Basis 1.4.46	Required on Toll Basis 1.4.46	Net Increase on Toll Basis
Trunk Circuits	2,148	2,668	3,604	1,456
Toll Circuits	1,220	—	1,796	576

In view of the considerable amount of work involved in the setting up and bringing into service such a number of trunk and toll circuits, a Regional Control Group was set up in March for the purpose of investigating causes of delays in bringing circuits into service and to expedite the work generally.

Since the formation of the Group the following additional circuits have been brought into service :—

	March	April
Trunk	34	91
Toll " A " and " B "	38	58

In an effort to relieve the London Trunk exchange of traffic, experiments are about to commence in devolving trunk traffic to the Toll Control positions of certain local exchanges in the London Region. For this purpose a total of forty-three circuits have been set up between London Trunk exchange and the following exchanges :

Forest Hill	3 circuits
Palmers Green	6 circuits
Prospect	10 circuits
Wanstead	9 circuits
Woolwich	15 circuits

EXTENSION OF HAYES EXCHANGE

A number of interesting difficulties were encountered during a recent extension at Hayes T.E. The exchange, a C.B.S. No. 1 multiple type of 15 positions, was already equipped much above the normal capacity for this type of switchboard and accommodation in the building for any normal extension did not exist. A request was received from the traffic staff for an additional four positions (two to be used as information desks), increase of subscribers' multiple from 1,800 to 2,000 lines—normal capacity for this type of switchboard is 800—an additional 220 subscribers' calling equipments, 30 incoming junction jacks, an increase of outgoing junction multiple making seven strips per panel—the designed capacity for the switchboard is six strips—and an additional 50 junction equipments.

The main difficulties in meeting this request were as follows :—

- (1) Provision of MDF/IDF to accommodate the additional circuits—the existing combined MDF/IDF already in two parts had completely outgrown its intended space, and no floor space existed in the room for a further frame.
- (2) Provision of equipment for 50 junctions. The Units Aux. Apps. used at this type of exchange already covered all available wall space in the MDF room, and an overflow of two racks had been fitted in a room on an upper floor used for VF equipment, completely filling same.
- (3) Fitting the four additional positions. This involved cutting the series type multiple and inserting the extra jacks for the new positions and a means of maintaining service on these lines had to be found.
- (4) Provision of one additional strip of outgoing junction multiple in all panels.

To overcome difficulty No. 1 the possibility of removing the wall between the MDF and power rooms was examined. As this proved impracticable consideration was next given to the only available space in the building, the linesmen's room on an upper floor, and it was found that sufficient space existed for three 19-in. mounting type racks. It was therefore decided that if strip-mounted junction equipment was provided on these racks, it was possible to provide the 50 additional circuits (difficulty No. 2), and at the same time transfer approximately 70 circuits being served by equipment on Racks Apparatus No. 6 in main frame room. This

allowed the recovery of two racks in that room and so provided sufficient space for the erection of eight verticals of frame MD.0/240.

Three 19-in. racks approximately 7 ft. high were made and erected in the linesmen's room and the strip mounted apparatus fitted and wired. Before the cables from the new racks could be terminated, it was necessary to shift one of the Racks Apparatus No. 6 sufficiently to allow the erection of two verticals of the new I.D.F. When this was done, and the equipment tested and circuits changed over, the two racks apparatus were recovered and the remaining six verticals of I.D.F. erected (a jumper field was provided between the new and old frames).

While this work was in progress the four additional switchboards (recovered from Waltham Cross) were overhauled and completely rewired. A small cordless type switchboard was fitted for use as a temporary information desk to allow the recovery of the existing two-position desk which occupied the floor space required for the additional four operating positions.

Next, it was decided to dismantle entirely the old C.T.S. and cut all cable ties back along the racking to the I.D.F. for approximately 10 ft. Hooks were then fitted into the ceiling directly above the racking and the cables lifted layer by layer and tied as near to the ceiling as possible. The top ironwork of the new positions was then removed and the positions lined up and fixed in the usual way.

To prevent interruption of service while the cables were cut, a strip of 20 spare calling equipments was fitted on one of the existing positions and cabled to the last of the old positions where the cable was terminated in cords and plugs. By the insertion of the 20 plugs into a strip of multiple jacks, substitute calling equipments were provided for the lines and thus the multiple cable concerned could be cut and the new jacks inserted without interference to the subscriber's service. The multiple for the new positions, each having two jacks, was made up previously. The old multiple cables were then lowered from the ceiling one layer at the time, and by careful measurement for the point to be cut in these cables just sufficient length was obtained for the ends to be stripped, waxed and terminated to the new jacks. A removable designation strip was provided with the temporary calling equipments to enable the operator to record all calls for metering purposes.

Point No. 4 was tackled by fitting pin type labels on all the existing outgoing junction multiple jacks and recovering all designation strips, thus providing space for the additional strips of jacks, but a further difficulty was found in the cable shelf which was completely full, and it was impossible to lower it. This was finally overcome by making a number of small iron brackets and fixing three per position to the underside of the existing cable shelf and arranging the four new multiple cables on them.

The work was completed with the provision of the additional 200 subs. multiple, 220 calling equipments and 30 incoming junction jacks which must make Hayes the largest C.B.S. No. 1 type exchange on record.

The total equipment is as follows :—

Number of positions	19
(2 used as I.D.)	
Subscribers' multiple	2,000
Calling equipments	1,900
Jack-ended junctions	230
O/G junction multiple	380

All positions equipped for dialling and 16 positions for key-sending.

L. P.

AN UNUSUAL LIFT FAULT.

A few months ago an unusual fault was detected in a lift in the Holborn telephone exchange. After the lift had been re-rope a peculiar "knock" was heard when the lift was running. It was fairly regular, and corresponded in frequency to about 8-10 ft. of the travel of the lift. All the obvious possible sources were sought, but without success. Finally, a ride was taken on top of the cage, when it was thought that the origin of the "knock" appeared to be one of the ropes.

Eventually an examination of the driving sheave brought to light the conditions illustrated in Fig. 1. All the grooves

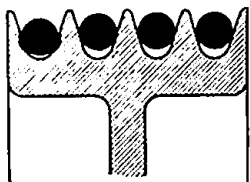

FIG. 1.

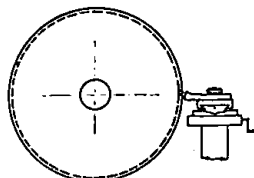

FIG. 2.

of the sheave were worn, but one had worn deeper than the remaining three. Thus the rope in this groove travelled

more slowly than its fellows, and made up the difference by "hopping" forward periodically. Presumably the "hop" occurred when the tension brought about by the difference in the speeds of the ropes had reached a limiting value which was sufficient to overcome the friction with the surface of the groove. In this lift equalising gear was only fitted on the balance weight.

It would have been an expensive matter to have removed the sheave to a lathe for turning the grooves. Instead of this, a tool carriage from a lathe was mounted as shown in Fig. 2, and the grooves turned to a common profile on site. The lift driving motor was fortunately D.C. supply, and was slowed by the insertion of a suitable resistance, and was thus used to drive the sheave for turning. After the grooves were turned, the lift was put back into service, and no further trouble experienced.

The difference in the respective effective depths of the grooves when the fault was discovered was less than $\frac{1}{8}$ in., and it is, of course, possible that in due course the fault may recur, but as the lift had seen nearly twenty years' service before the first appearance of the fault, it would seem that a "repeat" will not be of much consequence.

TELEPHONE AND TELEGRAPH STATISTICS—SINGLE WIRE MILEAGES AS AT MARCH, 1945 THE PROPERTY OF, AND MAINTAINED BY THE POST OFFICE

REGION	OVERHEAD			UNDERGROUND		
	Trunks and Telegraphs	Junctions	Subscribers *	Trunks and Telegraphs †	Junctions ‡	Subscribers ¶
Home Counties	15,840	47,681	336,618	1,693,661	391,051	1,413,815
South Western	7,212	48,436	257,534	893,092	154,254	777,916
Midland	7,836	36,494	201,423	956,113	300,692	1,042,214
Welsh and Border Counties ..	7,832	27,652	144,535	517,419	77,802	321,319
North Eastern	11,094	22,852	171,055	794,891	235,610	986,346
North Western	947	9,169	107,630	631,320	369,522	1,249,913
Northern Ireland	9,786	10,917	33,705	110,784	43,929	139,856
Scottish	23,243	36,687	182,403	752,267	245,394	835,699
Provinces	83,798	239,888	1,435,803	6,349,547	1,818,254	6,767,078
London	467	1,640	74,775	873,090	1,720,108	3,778,674
United Kingdom	84,265	241,528	1,510,578	7,222,637	3,538,362	10,545,752.

* Includes all spare wires.

† All wires (including spares) in M.U. Cables.

‡ All wires (including spares) in wholly Junction Cables.

¶ All wires (including spares) in Sub's. and mixed Junction and Sub's. Cables.

Staff Changes

Promotions

Name	Region	Date	Name	Region	Date
<u>Staff Engr. to Dep. R.D.</u>			<u>S.W.1 to Insp.</u>		
Reid, F.	E.-in-C.O. to N.E. Reg.	1.3.45	Carter, P. E.	S.W. Reg. to E.-in-C.O.	10.3.45
<u>Principal to C.R.E.</u>			Harrison, N. T.	E.-in-C.O.	25.12.44
**Beer, C. A.	Headquarters to N.W. Reg.	1.3.45	Webster, G. J.	E.-in-C.O.	19.11.44
<u>Reg. Engr. to C.R.E.</u>			Hustler, R. H.	E.-in-C.O.	20.5.44
Davis, H. G.	Scot. Reg. to N.W. Reg.	1.3.45	Johnston, P.	E.-in-C.O.	11.12.44
<u>Exec. Engr. to Regl. Engr.</u>			Banner, G. H.	E.-in-C.O.	1.3.45
Millard, C. W.	H.C. Reg. to Scot. Reg.	16.3.45	Barry, M.	E.-in-C.O.	12.2.44
<u>Area Engr. to T.M.</u>			Culkin, H.	N.E. Reg. to E.-in.C.O.	11.2.45
Millen, G. J.	L.T.R. to Preston	1.5.45	Western, M.	Test Sectn, B'ham	11.11.44
<u>Asst. Engr. to Exec. Engr.</u>			Smeaton, J. H.	E.-in-C.O.	11.3.45
Linck, H. C. A.	W. & B.C. Reg.	1.3.45	West, G. E.	E.-in-C.O.	10.4.45
England, A. G.	Scot. Reg. to Mid. Reg.	7.3.45	Taylor, A.	E.-in-C.O.	3.6.45
Hales, A. C.	E.-in-C.O. to Factories Dept.	1.4.45	Bywater, L. E.	E.-in-C.O.	11.3.45
<u>Chief Insp. to Asst. Engr.</u>			Davies, J. H.	E.-in-C.O.	3.6.45
Green, L.	E.-in-C.O.	2.3.45	Mitchell, E.	E.-in-C.O.	4.6.45
Selby, C. H.	W. & B.C.R. to E.-in-C.O.	26.4.45	Parker, E. J.	E.-in-C.O.	18.4.45
**Wheatley, E. K.	L.T.R.	22.3.45	Parnham, G. E.	E.-in-C.O.	11.4.45
Allison, A. J.	L.T.R.	22.3.45	Edmondson, J. S.	E.-in-C.O.	25.6.44
Perkins, J. J.	E.-in-C.O.	8.3.45	Greenhill, S. R.	E.-in-C.O.	4.6.45
<u>Chief Insp. to Chief Insp. with Allee.</u>			Bragg, E. J. W.	E.-in-C.O.	7.4.45
*Arram, H.	L.T.R.	1.1.45	Robinson, J. J.	E.-in-C.O.	13.4.45
Warne, G. C.	E.-in-C.O. to L.T.R.	19.5.45	Dorrell, G. H.	E.-in-C.O.	11.4.45
<u>Insp. to Chief Insp.</u>			Searls, A. W.	E.-in-C.O.	7.4.45
Harrison, H. W.	H.C. Reg.	15.3.45	Anderson, G. P.	E.-in-C.O.	7.4.45
**Rayns, F. H.	E.-in-C.O.	11.3.45	Ephgrave, E. V.	E.-in-C.O.	13.4.45
Woolford, S. W.	E.-in-C.O.	11.3.45	Harris, J. C.	N.W. Reg. to Con-tracts Dept.	15.4.45
Cheek, P.	E.-in-C.O.	1.2.45	Turtle, A. E.	Test Sectn, London	10.10.43
**McBryde, H.	N.E. Reg.	8.4.45	Clarke, L. W. C.	Test Sectn, London	25.1.44
Fradley, W.	N.E. Reg.	8.4.45	Gardner, F. A.	Cable Test Sectn.	2.2.44
Clarkson, W. J.	N.W. Reg.	11.3.45	Simmonds, F. W. N.	Cable Test Sectn.	7.9.43
Bell, G. W.	L.T. Reg.	18.3.45	<u>Asst. R.M.T.O. to M.T.O. II</u>		
Herlock, B. T.	E.-in-C.O.	8.1.45	Finney, C. W. M. S.	Exeter to E.-in-C.O.	23.3.45
Wildig, H.	Mid. Reg.	11.4.45	<u>Tech. Asst. to M.T.O. III</u>		
Banham, S. H.	Test Sectn, London	9.8.43	Swire, W. L.	London to E.-in-C.O.	6.5.45
Torbet, D. K.	N.E. Reg. to W. & B.C. Reg.	29.4.45	<u>Tech. Asst. to Asst. R.M.T.O.</u>		
Neall, E. W.	S.W. Reg.	6.5.45	Mathewson, F. J.	Leeds to N. Ire. Reg.	13.5.45
Freeman, A. W.	Test Sectn, London	1.9.43	<u>Asst. Phys. or Chem. to Phys. or Chem.</u>		
Head, D. E.	E.-in-C.O.	15.4.45	Shotton, D. C.	Test Sectn., B'ham to E.-in-C.O.	24.5.45
Sallis, R. T. G.	E.-in-C.O.	23.4.45	<u>Fifth Engr. to Fourth Engr.</u>		
			Lindsay, J.	H.M.T.S.	21.9.43
			<u>D'sman Cl. II to D'sman Cl. I</u>		
			Rooks, E. W.	N.W. Reg. to H.C. Reg.	3.4.45
			Nichols, A. J.	H.C. Reg. to N. Ire. Reg.	5.4.45

* Shown incorrectly in the April, 1945 issue, as Arram, H.

** In absentia

Retirements

Name	Region	Date	Name	Region	Date
<u>Dep. C.R.E.</u>			<u>M.T.O. III</u>		
Phillips, C. H.	L.T.R.	28.2.45	Salter, F. J.	E.-in-C.O.	28.2.45
<u>Exec. Engr.</u>			<u>Asst. Engr.</u>		
Little, W. R.	L.T.R.	28.2.45	Missen E.	E.-in-C.O.	15.3.45
King, A. G.	W. & B.C. Reg.	28.2.45	Satchwell, W. A.	N.W. Reg.	31.3.45
Drury, R. H.	E.-in-C.O.	31.3.45	Paish, P. B.	H.C. Reg.	31.5.45
			Perie, W.	Scot. Reg.	31.3.45

Retirements—continued.

Name	Region	Date	Name	Region	Date
<i>Chief Insp. with Allee.</i>			<i>Insp. (continued)</i>		
Kenyon, T. ..	N.W. Reg. ..	31.3.45	Abbott, R. W. O. ..	L.T.R. ..	22.3.45
Roberts, W. A. ..	L.T.R. ..	18.5.45	Reeves, F. C. ...	H.C. Reg. ..	16.3.45
<i>Chief Insp.</i>			Wright, W. J. ..	L.T.R. ..	30.3.45
Wordley, E. H. ..	Mid. Reg. ..	10.4.45	Hodgson, F. M. ..	L.T.R. ..	31.3.45
Read, P. J. ..	S.W. Reg. ..	28.4.45	Dodd, V. W. ..	L.T.R. ..	31.3.45
Devon, H. ..	N.W. Reg. ..	31.5.45	Thomas, W. E. ..	E.-in-C.O. ..	31.3.45
McDonald, W. ..	Scot. Reg. ..	31.3.45	Reid, D. ..	Scot. Reg. ..	1.5.45
<i>Insp.</i>			Cooper, W. ..	Scot. Reg. ..	13.5.45
Berry, J. J. ..	S.W. Reg. ..	27.2.45	Bloss, B. ..	L.T.R. ..	13.5.45
Ferris, J. T. ..	S.W. Reg. ..	9.3.45	Hodgson, A. J. ..	S.W. Reg. ..	19.5.45
Rule, C. ..	L.P. Reg. ..	19.3.45	Hanrahan, P. ..	Scot. Reg.-	31.5.45
			<i>Senior D'sman</i>		
			Timberlake, E. ..	E.-in-C.O. ..	31.5.45

Transfers

Name	Region	Date	Name	Region	Date
<i>Staff Engr.</i>			<i>M.T.O. III</i>		
Little, G. J. S., G.M. ..	N.W. Reg. to E.-in-C.O.	1.3.45	Hunt, E. T. ..	E.-in-C.O. to S.W. Reg.	12.3.45
			Stokes, F. W. ..	N. Ire. Reg. to E.-in-C.O.	18.4.45
<i>Area Engr.</i>			<i>Insp.</i>		
Birch, S. ..	Scot. Reg. to E.-in-C.O.	1.4.45	Sutcliffe, N. ..	E.-in-C.O. to N.E. Reg.	12.2.45
			Finnamore, A. J. ..	L.T.R. to E.-in-C.O. ..	1.3.45
			Whiteley, R. G. ...	Contracts Dept. to S.W. Reg.	19.3.45
<i>Asst. Engr.</i>			Reeves, E. S. ..	L.T.R. to E.-in-C.O. ...	26.3.45
Neate, A. D. ..	E.-in-C.O. to H. C. Reg.	1.4.45	<i>D'sman Cl. I</i>		
Smart, J. H. C. ..	Mid. Reg. to N.W. Reg.	1.4.45	Lewis, L. W. ..	N.E. Reg. to S.W. Reg.	25.2.45

Deaths

Name	Region	Date	Name	Region	Date
<i>Insp.</i>			<i>Insp. (continued)</i>		
Brazier, J. H. ..	N.W. Reg. ..	25.1.45	Squires, F. W. ..	E.-in-C.O. (missing, presumed killed)	27.3.45
Hutton, R. W. ..	N.W. Reg. ..	5.2.45	Thompson, L. M. ..	L.T.R. ..	18.4.45
Keefe, C. A. ..	S.W. Reg. ..	14.2.45			

CLERICAL GRADES

Promotions

Name	Region	Date	Name	Region	Date
<i>E.O. to S.O.</i>			<i>C.O. to E.O.</i>		
Batey, T. W. ..	E.-in-C.O. ..	1.4.45	Elston, V. (Miss) ..	E.-in-C.O. ..	1.4.45
Collett, L. C. ..	E.-in-C.O. ..	1.4.45	O'Brien, M. E. M. (Miss)	E.-in-C.O. ..	1.4.45
			Parry, T. R. ..	E.-in-C.O. ..	1.4.45

Retirements

Name	Region	Date	Name	Region	Date
<i>Staff Officer</i>			<i>Staff Officer (continued)</i>		
Lewis, H. E. C. Major ..	E.-in-C.O. (on loan to L.T.R.)	2.3.45	Pursall, S. ..	E.-in-C.O. ..	31.3.45
			Wilcock, S. ..	E.-in-C.O. ..	31.3.45

Junior Section Notes

Doncaster, Grimsby and Lincoln Centres

In view of the changed war conditions it was felt that the time was opportune to revive interest in the Junior Centres in the Lincoln Telephone Area. A good response was apparent and inaugural meetings were therefore held in May, 1945, at Doncaster, Grimsby and Lincoln, at which the Area Engineer, Mr. Smithers, recommended an early revival of the Centres' activities. This was agreed in each case and a Committee was elected forthwith with instructions to arrange for a session to commence in October, 1945.

The officers elected as Chairmen and Secretaries are shown below :—

Centre	Chairman	Secretary and Treasurer
Doncaster ..	L. F. Cary	A. E. Davis
Grimsby ..	A. L. Deighton	T. J. Charlton
Lincoln ..	W. Simpson	L. T. Mullins

Dundee Centre

After a lapse of five years the Dundee centre of the Junior Section has resumed its activities. Four meetings have been held and were well attended. It is hoped to have outings during the summer months. The membership numbers 90. At the Annual General Meeting the following office bearers were elected :—

Chairman : Mr. J. Singer.
Vice-Chairman and Librarian : Mr. A. C. Gow.
Secretary : Mr. D. A. Brown.
Treasurer : Mr. J. Lettice.

Our thanks are extended to the Senior Section for their co-operation during the session.

D. A. B.

Edinburgh Centre

The Annual General Meeting of the above Centre was held on March 14th. The principal item on the agenda was the appointment of the office bearers for the forthcoming year.

Committee elected was as follows :—

Chairman : Mr. J. M. Wright.
Vice-Chairman : Mr. D. Strachan.
Secretary and Treasurer : Mr. G. J. Ford.
Librarian : Mr. H. W. Onwin,

Reviewing the centre's status at the end of its first year, the membership (52) and financial aspects are good, but the attendances at the meetings leave much to be desired ; so we would say to all members : make a date in the winter months with us and keep it ; furthermore, bring along a colleague. G. J. F.

Exeter Centre

The Exeter Branch of the I.P.O.E.E. (Junior Section) was reopened at a special meeting held on November 9th, 1944. Since that date six meetings have been held.

The Officers for the 1945/6 Session are :—

Chairman : Mr. W. J. Foster.
Vice-Chairman : Mr. G. F. Lampert.
Secretary : Mr. F. G. Gill.
Treasurer : Mr. H. I. Lyons.
Librarian : Mr. C. J. Williams.

BOARD OF EDITORS

A. J. GILL, B.Sc., M.I.E.E., F.I.R.E., Chairman.
F. E. NANCARROW, O.B.E., A.R.C.Sc., M.I.E.E.
P. B. FROST, B.Sc., M.I.E.E.
A. H. MUMFORD, B.Sc.(ENG.), M.I.E.E.
C. W. BROWN, A.M.I.E.E.
G. H. S. COOPER.
H. LEIGH, B.Sc.(ENG.), A.M.I.E.E., Acting Managing Editor.
G. E. STYLES, A.M.I.E.E., Acting Assistant Editor.
A. J. BAKER, Secretary-Treasurer.

Copyright

The entire contents of this JOURNAL are covered by general copyright, and special permission is necessary for reprinting long extracts, but Editors are welcome to use not more than one-third of any article, provided credit is given at the beginning or end thus : " From the *Post Office Electrical Engineers' Journal*."

The Board of Editors is not responsible for the statements made or the opinions expressed in any of the articles in this JOURNAL, unless such statement is made specifically by the Board.

Communications

All Communications should be addressed to the Managing Editor, *P.O.E.E. Journal*, Engineer-in-Chief's Office, Alder House, Aldersgate Street, London, E.C.1. Telephone : HEADquarters 1234. Remittances should be made payable to "*The P.O.E.E. Journal*" and should be crossed "& Co."

Binding Cases

Cases for binding are available, and may be obtained from the Local Agents for 1s. 9d. Subscribers can have their copies of Volumes bound, at a cost of 3s., by sending the complete set of parts to the Local Agents or to the *P.O.E.E. Journal*, Engineer-in-Chief's Office, Alder House, Aldersgate Street, London, E.C.1. Orders for binding for Vols. 1-19 should indicate whether the original binding case with black lettering, or the later pattern with gold, is required. Cases with gold lettering are the only type stocked from Vol. 20 onwards.

Back Numbers

The price of the JOURNAL, which is published quarterly, is 1s. (1s. 3d. post free) per copy, or 5s. per annum post free. Back numbers can be supplied, subject to availability of stocks, at 1s. each (1s. 3d. post free). Orders for back numbers may be sent to the Local Agents or to the Publishers.

Advertisements

All communications relating to space reservations should be addressed to the Advertisement Editor, *P.O.E.E. Journal*, Alder House, Aldersgate Street, London, E.C.1. Communications regarding advertisement copy, proofs, etc., should be addressed to the Publishers, Messrs. Birch & Whittington (Prop. Dorling & Co. [Epsom], Ltd.), 49 Upper High Street, Epsom, Surrey.



The AvoMeter is one of a useful range of "Avo" electrical testing instruments which are maintaining on active service and in industry the "Avo" reputation for an unexcelled standard of accuracy and dependability—in fact, a standard by which other instruments are judged.

ONE INSTRUMENT measures:—
 Current, A.C. and D.C. (0 to 10 amps.)
 Voltage, A.C. and D.C. (0 to 1,000 v.)
 Resistance (up to 40 megohms)
 Capacity (0 to 20 mfd.)
 Audio-frequency Power Output (0 to 4 watts)
 Decibels (—25 Db. to + 16 Db.)

Orders can now only be accepted which bear Government Contract Number and Priority Rating.

'AVO'
 Regd. Trade Mark

Meters that Matter

THE Model 7 Universal AvoMeter is the world's most widely used combination electrical measuring instrument. It provides 50 ranges of readings and is guaranteed accurate to B.S. first grade limits on D.C. and A.C. from 25 to 100 cycles. It is self-contained, compact and portable, simple to operate and almost impossible to damage electrically. It is protected by an automatic cut-out against damage through severe overload, and is provided with automatic compensation for variations in ambient temperature.

Sole Proprietors and Manufacturers

THE AUTOMATIC COIL WINDER & ELECTRICAL EQUIPMENT Co. Ltd
 Winder House, Douglas Street, London, S.W.1 Phone : VICTORIA 3404-8

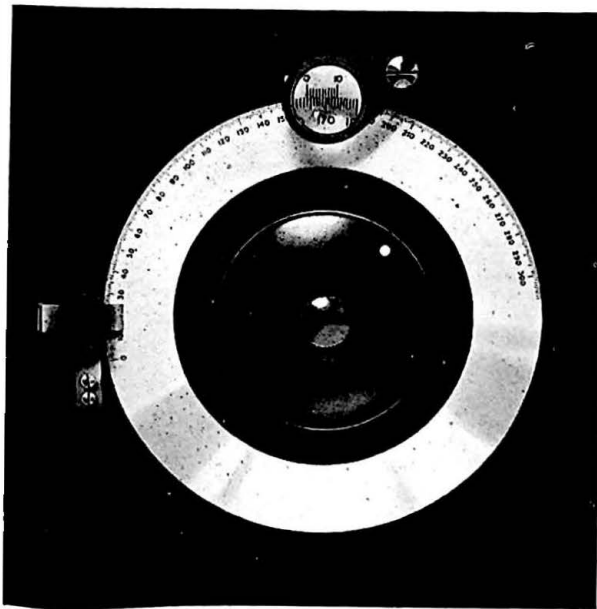

DIAL TYPE D-III

For some purposes, a dial larger than our standard $4\frac{1}{2}$ " type is desirable, and we have therefore introduced a 6" diameter dial, engraved 0-300, over 180°.

It is silvered and lacquered, and is provided with a sprung vernier for accurate reading.

Our standard 50:1 slow motion drive is fitted, and the unit is particularly suitable for use on Wavemeters, Signal Generators, etc.

The Dial can be supplied with or without Dial Lens Type D-112-A and Dial Lock Type D-128-A.

MUIRHEAD

MUIRHEAD & CO. LTD., ELMERS END, BECKENHAM, KENT
 TELEPHONE: BECKENHAM 0041-0042.

FOR OVER 60 YEARS DESIGNERS & MAKERS OF PRECISION INSTRUMENTS



PRINTING TELEGRAPH APPARATUS

TELEPRINTERS
HIGH SPEED MORSE INSTRUMENTS
RELAYS
AND REPEATERS

CREED AND CO. LTD
CROYDON



**How much can you
condense a condenser**



Midget Condensers

Midgets in size but giants in performance are these U.I.C. Miniature Condensers. Especially suitable for use in the latest Service type miniature radio transmitters and receivers, they are efficient and dependable under all climatic conditions. Made to specification K.110. Type approved. Full details on request.

UNITED INSULATOR CO. LTD.
12-22 LAYSTALL ST., LONDON, E.C.1

Tel: TERminus 7383 (5 lines) Grams: Colanel, Smith, London

THE PIONEERS OF LOW-LOSS CERAMICS

EXECUTIVES!

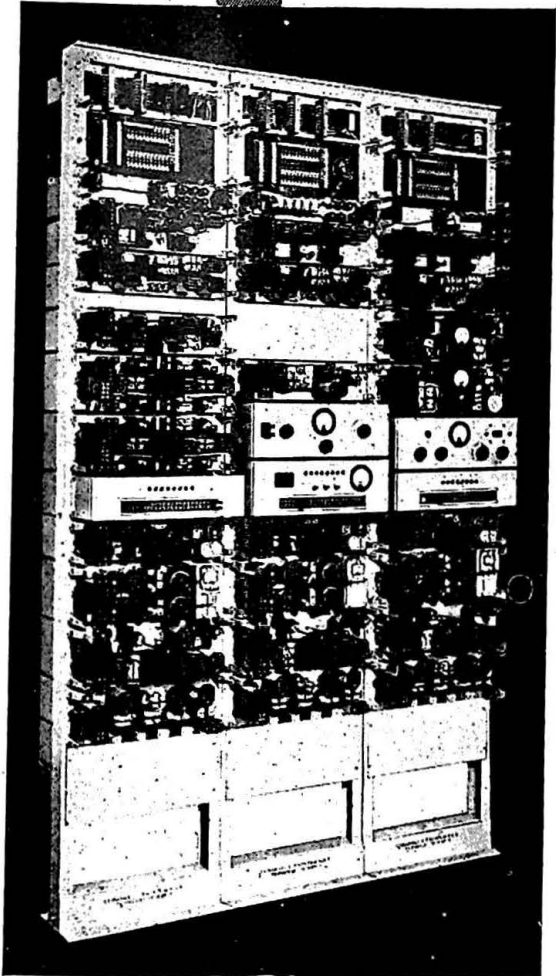

*Typical
Telecommunications
Transmission
Terminal Station.*

MORE TELEGRAPH AND TELEPHONE CIRCUITS WITHOUT EXTRA WIRES

To cater for increased telephone or telegraph traffic it is not necessary to provide costly additional cable or open-wire circuits. The existing route or routes can be canalised to serve extra requirements, and the resultant transmission is superior to normal.

The equipment which renders this possible is the joint product of two Companies of repute. It is the result of years of laboratory research and close technical liaison between the transmission experts of both Companies. It can be relied upon to be the most modern development of its kind.

For telecommunications of the future you will need—

ATE/TMC TELECOMMUNICATIONS TRANSMISSION EQUIPMENT

MANUFACTURERS

Please address enquiries to:—

**AUTOMATIC TELEPHONE & ELECTRIC CO. LTD. • TELEPHONE MANUFACTURING
COMPANY LTD.**

STROWGER WORKS, LIVERPOOL

West Dulwich • London • S.E.21

ENGLAND

and
St. Mary Cray • Kent



ANACOS Wires for
TELEPHONE & TELEGRAPH
 ALSO TAPES & BINDERS
 In Copper, Bronze & Cadmium-Copper

FREDERICK SMITH & CO. LTD. (Incorporated in The London Electric Wire Company and Smiths, Limited.)
ANACONDA WORKS, SALFORD, 3, LANCS.
 Telephone : BLACKFRIARS 8701 (9 lines).
 Telegrams : "ANACONDA" MANCHESTER

for **HIGH • HIGHER and HIGHEST FREQUENCIES!**

TENAPLAX Co-axial Cable



SOME TENAPLAX CABLES HAVE **60% AIR INSULATION**
 Patented method of construction reduces losses to a minimum.

- Plastic Cover
- Electrical Screening
- Alkathene Sleeve
- Braided Alkathene Filaments
- Conductor

We also make : **RADIO SLEEVING** • **INSULATING TUBING**
SPECIAL TUBING FOR CONVEYING LIQUID FOOD, ETC.
COVERED WIRES AND CABLES. Write to :

TENAPLAS LTD., 7 PARK LANE, LONDON, W.1

Specially designed for operation under
ADVERSE ATMOSPHERIC CONDITIONS

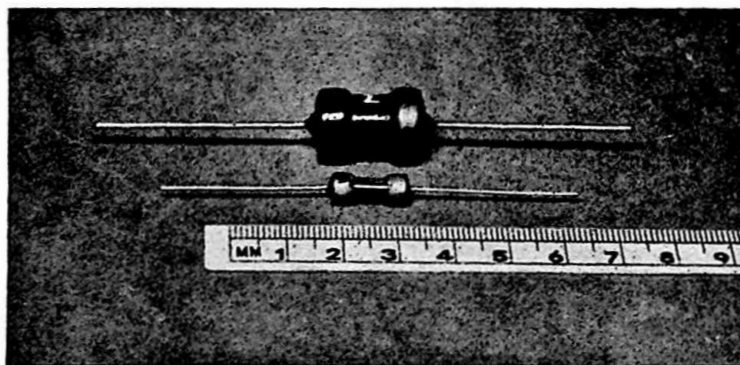

KH (Miniature H type) unit.
 Available with up to six series elements.

Miniature W or WX Westector.
 Available with up to six series elements.

These new miniature Westinghouse Metal Rectifiers have many advantages over the older types. Their size allows them to be suspended in the wiring of the apparatus, or they may be fixed on a "group board." End wires are provided for soldered connections.

Specially sealed for use in damp atmospheres—"fungus" proof—and can be treated to provide stable characteristics at high temperatures.
 We shall be pleased to send you full details.



METAL RECTIFIERS
 WESTINGHOUSE BRAKE & SIGNAL CO. LTD.,
 Pew Hill House, Chippenham, Wilts.



SIEMENS

TELECOMMUNICATION EQUIPMENT *for service in all parts of the world*

Contractors for
supply and installation of
complete Automatic and
Manual Telephone Exchanges for
Public and Private Service,
Automatic and Manual Trunk
Exchanges, all types of Telephone
Cables for Trunk and Local
Service, and Carrier-Current
and Repeater Equipment for
Telephone Lines.

Siemens Telecommunication
Equipment is giving thoroughly
efficient service in all parts of
the world.

PRIVATE TELEPHONE SYSTEMS

PUBLIC TELEPHONE EXCHANGES

CARRIER-CURRENT EQUIPMENT

TELEPHONE INSTRUMENTS

of all types

PROTECTIVE APPARATUS

RELAYS

TELEPHONE CABLES

CARRIER-CURRENT CABLES

LOADING COILS

CELLS and BATTERIES

Dry, Fluid, and Inert

SIEMENS BROTHERS & CO., LTD · WOOLWICH · S · E

Telephone: WOOLWICH 2020

Ericsson

66 years of steady progress in telephony and its applications sees Ericssons in their extensive plant to-day utilising Modern Plastics for the improvement of telephone design and efficiency. Ericssons have unrivalled experience in the production of telephone equipment required to function under tropical and similar extreme conditions—taking full advantage of the application of Plastics in this connection. Enquiries welcomed.

ERICSSON TELEPHONES LTD., Head Office: 56, Kingsway, London, W.C.2. Tel.:—HOL. 6936. Works Beeston, Notts.



CAPCO

REGISTERED TRADE MARK

QUARTZ CUTTING MACHINES WITH

AUTOMATIC, GRAVITY or HAND FEED

ALSO

JIGS — FIXTURES and ATTACHMENTS

available for dealing with "QUARTZ" of every known size or type
LATEST DESIGN

*incorporates higher cutting speeds. Totally enclosed transparent splash guards
giving greater protection for the operator from cutting Lubricants*

WRITE FOR DETAILS.

CAPLIN ENGINEERING CO. LTD.

25 years of service to the engineering
and allied trades.

Well over one thousand "CAPCO"
machines in use to-day, including hun-
dreds of special machines and apparatus.
"CAPCO" is synonymous with accuracy.

*Designers and manufacturers of Capco Sound-on-Film recorders and equipment. Capco built recorders are in use at
Elstree, Pathe News and Universal Talking News, etc. Patentees and manufacturers of Capco Enamelled Wire
Cleaning machines.*

BEACONSFIELD RD WILLESDEN, LONDON, N.W.10

Sole Agents : CAPCO (Sales) LTD.

Telephone : WILlesden 0067-3



x

STANDARD WITH THE BRITISH POST OFFICE

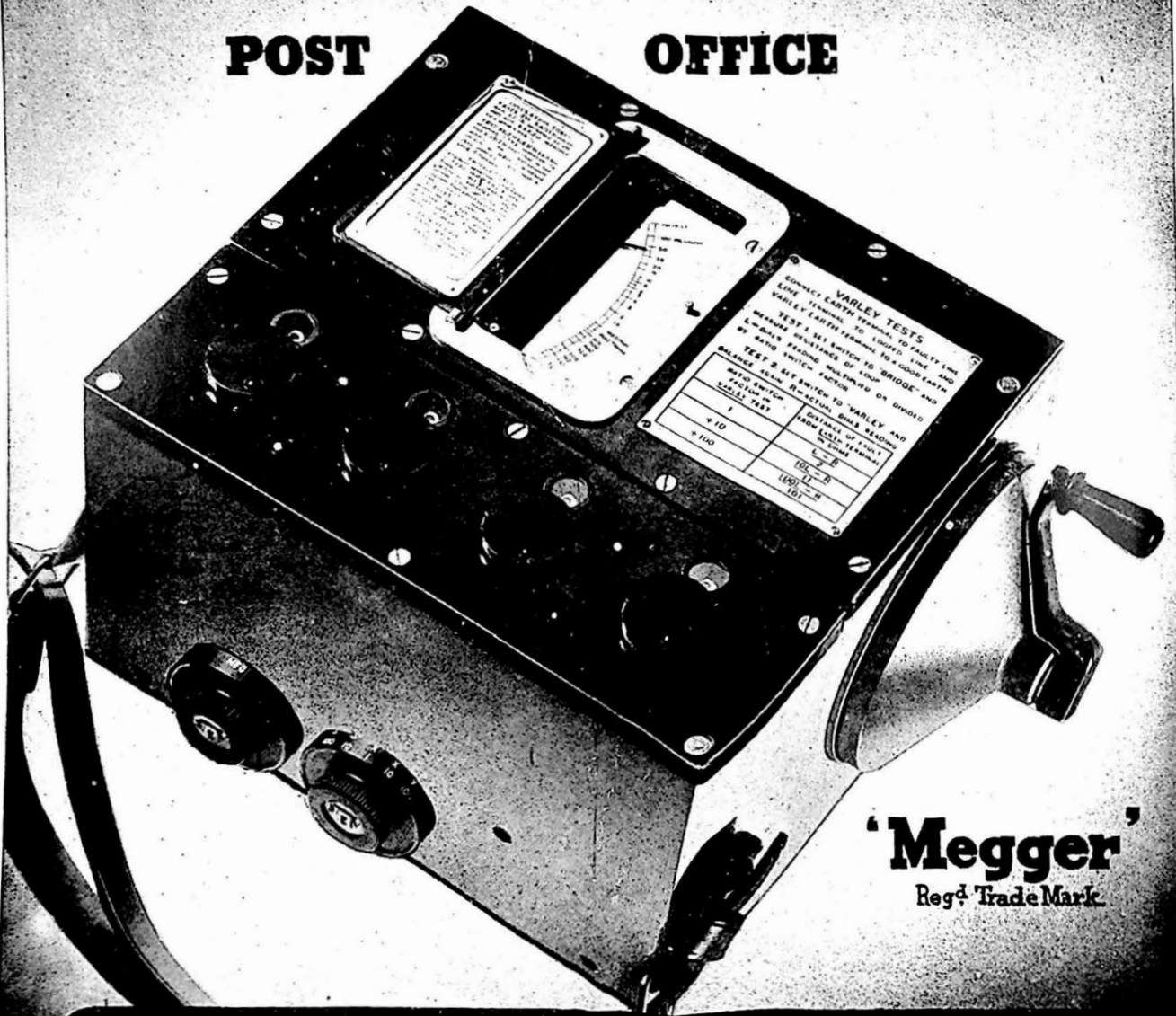

'Megger'
Regd Trade Mark

THE BRIDGE-MEG TESTING SET used by the British Post Office is a portable, self-contained instrument combining the functions of an Insulation Tester and a Wheatstone Bridge; it can be used for fault location by the Varley Loop method. Facilities can also be provided whereby, with the use of an external galvanometer and resistance box, the instrument may be used for making Murray Loop tests. Insulation range 100 megohms at 500 volts. Bridge range 0.01 to 999,900 ohms. Size $7 \times 8\frac{3}{4} \times 12$ ins. Weight $12\frac{3}{4}$ lbs. Mains operated instruments are also supplied to the British Post Office. Ask for list X 267.

EVERSHED & VIGNOLES LTD., CHISWICK, LONDON, W.4
TELEPHONE: CHISWICK 1370 * TELEGRAMS: "MEGGER" CHISK, LONDON



*'The best
of prophets
of the future
is the past'*—BYRON

BEHIND Alton stationary batteries stands a great tradition of painstaking effort and progressive improvement. To-day the result is reflected by the high standard of performance of Alton batteries in Power Houses, Telephone Exchanges and Broadcasting Stations. Because Alton practice is rooted in such fine tradition, to-morrow Alton batteries will be chosen for the maintenance of power supply in vital installations.

ALTON

BATTERIES OF MERIT

THE ALTON BATTERY COMPANY LIMITED
(Sole Suppliers of FULLER Stationary Batteries)
ALTON, HANTS

Phone: Alton 2267 and 2268 Grams: 'Battery, Alton'

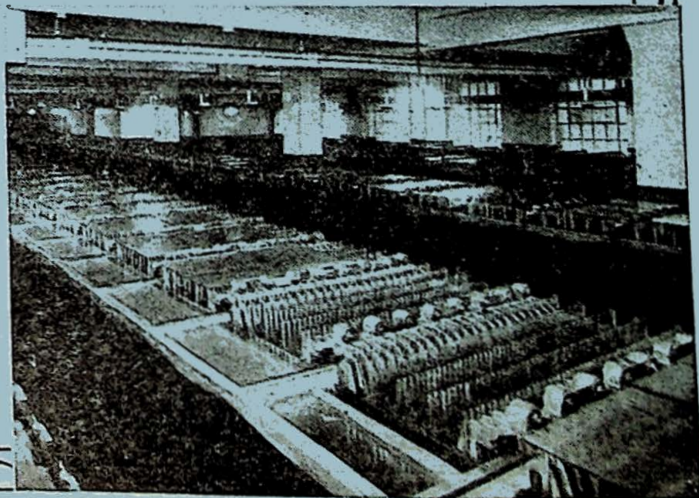

MAINTAINING EFFICIENCY

THE HIGH STANDARD OF EFFICIENCY
OF PIRELLI - GENERAL TELEPHONE
CABLES IS MAINTAINED BY THE
CONTINUOUS RESEARCH WORK OF
AN EXPERIENCED TECHNICAL STAFF.

TELEPHONE
SOUTHAMPTON
2141 (5 lines)

PIRELLI-GENERAL
CABLE WORKS, Ltd., SOUTHAMPTON.

TELEGRAMS
"PIRELLI-KAYBEL"
SOUTHAMPTON

$\frac{3}{100}$ of an Inch X 1 mile

and the Three Cores
of Flux are there

We make Ersin Multicore Solder Wire as fine as 22 S.W.G. (.028 in.) and it has three cores of Ersin Flux throughout a continuous length of one mile. We mention 22 S.W.G. to emphasise the fact that, if the three cores of flux are always there in this fine gauge, then they are certainly present in the more commonly used larger gauges—13 to 18 S.W.G. Use Ersin Multicore and

1. You need not worry whether or not the flux is present. 3 cores ensure it.
2. You get Ersin Flux—the fastest action, non-corrosive, safety flux (approved by A.I.D. and G.P.O.) which speeds up soldering and obviates "H.R." or "dry" joints.

If you are engaged on Government contracts, write for technical information and samples.



ERSIN MULTICORE

The Solder Wire with 3 Cores of Non-Corrosive Ersin Flux.

MULTICORE SOLDERS LTD. COMMONWEALTH HOUSE, NEW OXFORD ST., LONDON, W.C.1. Tel. CHAncery 5171/2