

THE POST OFFICE ELECTRICAL ENGINEERS' JOURNAL

VOL. 36

JULY, 1943

PART 2

CONTENTS

	PAGE
A VERTICAL MAILS ELEVATOR—W. R. J. Lowe, B.Sc.(Eng.), A.M.I.E.E.	33
MEASUREMENTS ON HIGH-FREQUENCY CABLES AND FEEDERS—PART I—TUNED CIRCUIT SUBSTITUTION METHODS—R. F. J. Jarvis, Ph.D., and J. C. Simmonds, Ph.D. . .	37
EMISSION-TYPE PHOTO-ELECTRIC CELLS—A. C. Lynch, M.A., and J. R. Tillman, Ph.D.	43
AIR RAID DAMAGE TO POST OFFICE TELECOMMUNICATIONS—PART IV—DAMAGE TO OVERHEAD PLANT—E. C. Baker	46
THE LONDON TELECOMMUNICATIONS REGION POWER SECTION WORKSHOPS—C. A. R. Pearce, M.Sc., A.M.I.E.E.	48
CABLE TEST—LONDON—A. E. Mercer	51
SOME AMERICAN ARMY LINE CONSTRUCTION TOOLS—H. F. Daniels and E. J. V. Turner	53
BOOK REVIEWS	56, 64
NOTES AND COMMENTS	57
REGIONAL NOTES	59
STAFF CHANGES	63

Price 1/6 net

THE INSTITUTION OF POST OFFICE ELECTRICAL ENGINEERS

GE CALLOY

RADIO CORES

MAIN ADVANTAGES

- Greater magnification.
- Higher selectivity.
- Small size.
- Reduced costs.
- Robust construction.
- Simple adjustment.
- Non-rusting.

SALFORD ELECTRICAL INSTRUMENTS LTD.

PEEL WORKS, SALFORD, 3. Telephones: BLAckfriars 6688 (6 lines). Telegrams and Cables: "Sparkless, Manchester"
 PROPRIETORS: THE GENERAL ELECTRIC Co. Ltd., OF ENGLAND

STABILITY

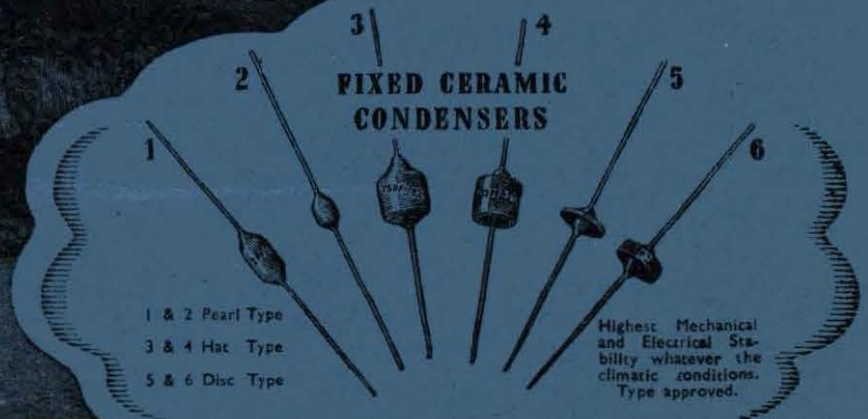
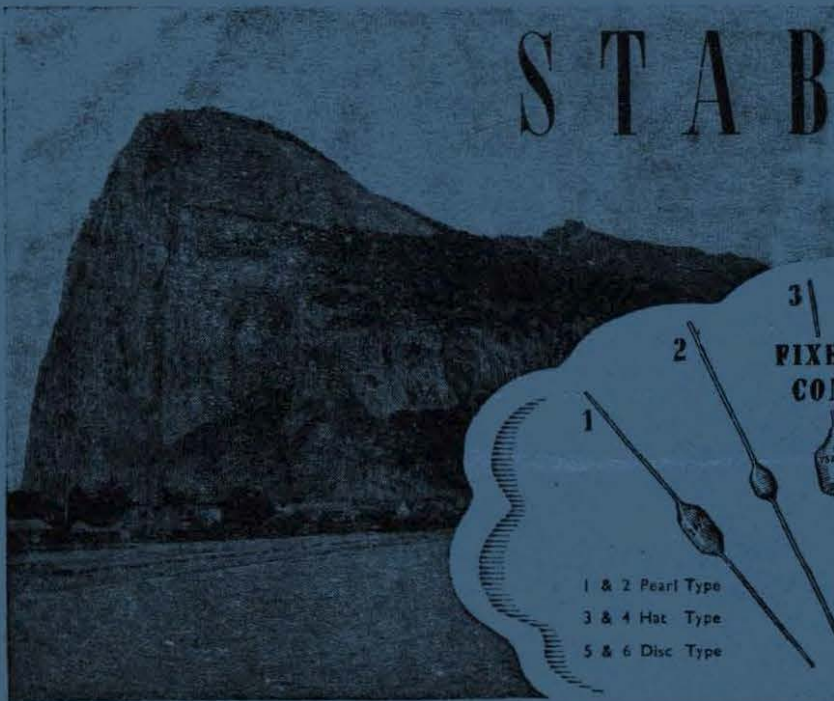

UNITED INSULATOR CO. LTD.

12-20 LAYSTALL STREET, LONDON, E.C.1

Phone: TERminus 7383

Grams: Calanel, Phone, London

*The
Pioneers
of low-loss
Ceramics*

THE POST OFFICE ELECTRICAL ENGINEERS' JOURNAL

Vol. XXXVI

July, 1943

Part 2

A Vertical Mails Elevator

W. R. J. LOWNE, B.Sc. (Eng.), A.M.I.E.E.

U.D.C. 383:621.867
621.876

A conveyor system is described, a novel feature of which is a vertical elevator for lifting baskets of mail. It consists of a band on which are mounted arms which hold the baskets during the vertical motion and fold over the drum at the top, discharging the baskets on to a horizontal conveyor of normal design.

Introduction.

THE Head Post Office at Birmingham consists of two buildings connected by a bridge over the street which separates them. Owing to floor space limitations it has been necessary to house the Postmen's Office on the ground floor of the east building and the Letter Sorting Office on the first floor of the west building. Incoming letter mail is received at both buildings, but is sorted in the west building only; after sorting, the faced letters are conveyed to the Postmen's Office in the east building, from whence they go out for delivery in the town. It therefore becomes necessary to transfer mail (comprising letter packets, faced letters and loaded bags) to and fro between the two buildings. This is effected by the elevator and conveyor system, which forms the subject of this article.

Arrangement of Conveyor System.

The layout of the elevator and conveyor system is shown in Fig. 1. Mail is conveyed from the ground

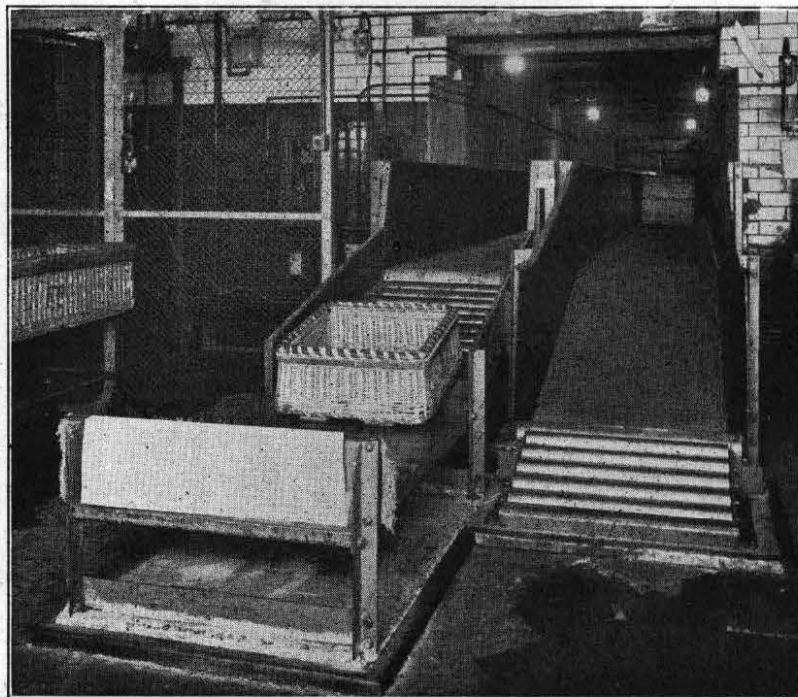

FIG. 2.—HORIZONTAL CONVEYOR BANDS SEEN FROM WEST BUILDING.

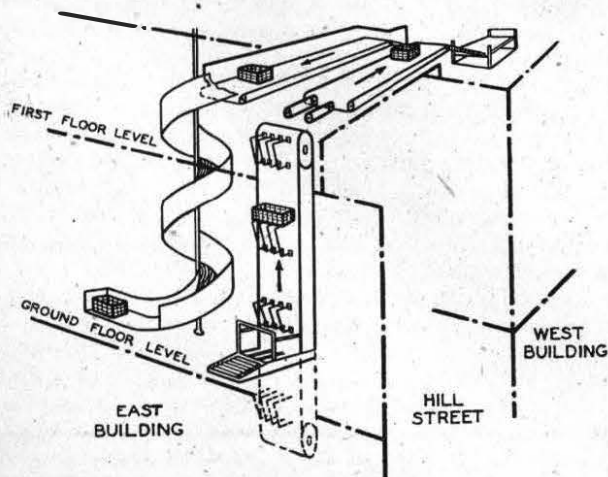

FIG. 1.—LAYOUT OF ELEVATOR AND CONVEYOR SYSTEM.

floor to the first floor of the east building by the vertical elevator, which discharges on to a horizontal band conveyor running underneath the street bridge. Mail from the west building is loaded on to a second horizontal band conveyor running beside the first but in the opposite direction, and at the east end of the bridge the mail is discharged into a spiral chute, which conveys it to the ground floor of the east building.

Horizontal Conveyor Bands and Spiral Chute.

Fig. 2 shows a view of the horizontal conveyors as seen from the west building. The loading and discharging rollers and the two types of basket used can be seen in the figure. As the horizontal band conveyors and the spiral chute are of conventional type, it is proposed to describe in detail only the vertical elevator which is a novelty in Post Office

practice. It may be mentioned in passing, however, that as a result of experiments on a model at the makers' works, the best angle for the chute was found to be 25° , and it was established that baskets of faced letters discharged on to the chute at the speed of the horizontal band conveyor (130 ft. per minute) would not sway or check in transit. The experiment also indicated that an inner side to the chute was unnecessary. Nevertheless, as an additional safeguard, provision was made in the specification for the incorporation of a slowing device on the chute should it be found that the baskets were arriving at too high a speed. Such a device has not been found necessary, and the chute, as constructed, is capable of dealing with either full bags or full or empty baskets without difficulty.

Elevator.

The quest for a robust, trouble-free vertical mails elevator has for long occupied the attention of engineers concerned with postal mechanisation. The two types of elevator available in the past have been the ordinary flat band elevator and the twin band elevator. Of these the former suffers from the

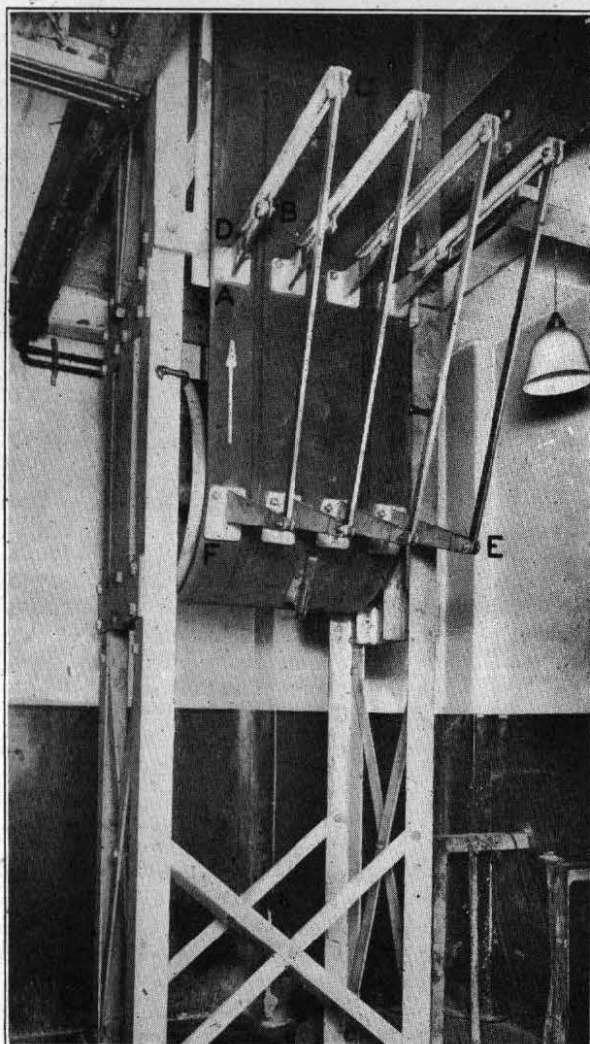

FIG. 3.—SUPPORTING TOWER AND LOWER DRUM.

disadvantage that it will not function at an angle much in excess of 17° to the horizontal if backsliding is to be avoided, although with the addition of slats it could work up to an angle of 30° . The slats, if high enough to prevent slipping, were, however, liable to be torn out. With the twin band conveyor

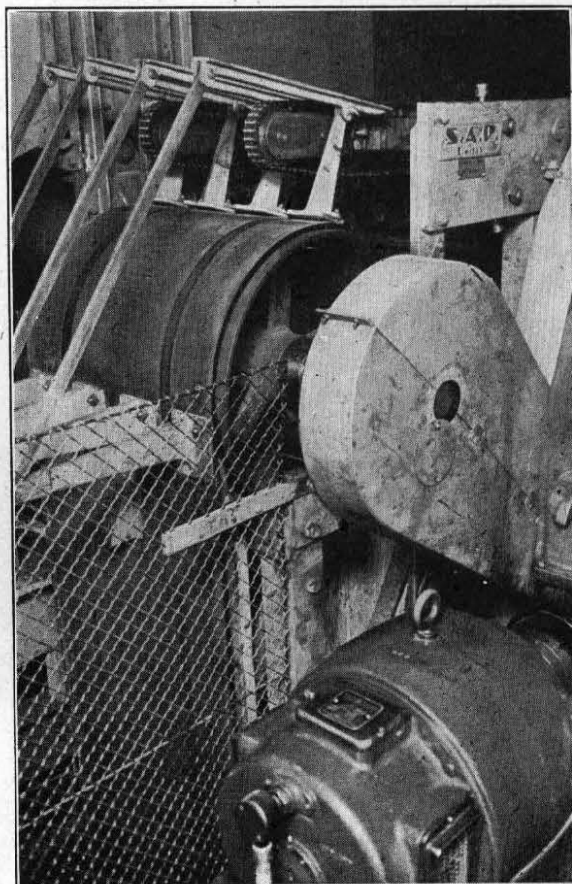

FIG. 4.—TOP OF BAND SHOWING CHAIN DRIVES AND MOTOR.

the maximum angle was about 60° to the horizontal. Both these types of elevator are extravagant users of floor space, which is so valuable in sorting offices.

The vertical elevator about to be described was introduced by S.A.P.Ltd., a year or two before the outbreak of war: elevators of this type, although much smaller, have been installed by them in a number of the national newspaper offices. Although it is yet too early to say that this elevator will prove entirely satisfactory as a basis for a standard design, it has now been in service for more than twelve months, no major troubles have been encountered, and the elevator has fulfilled all the claims made for it by the makers.

The principle of the elevator is illustrated in Fig. 3. The cradle linkage consists of a rigid arm AB bolted to the band at A and carrying a link CBD pivoted at B. This link has a flat upper surface $1\frac{1}{2}$ in. wide, on which the baskets are supported. The lengths of the various links are so proportioned that when passing over the top of the upper drum the link CBD pivots on the pin-joint B and remains approximately horizontal while the arm AB travels to the vertical

position normal to the surface of the upper drum. This action can be seen in Fig. 4, which shows a cradle going over the top of the elevator at the moment after the basket has been discharged on to the "take away" chains. The end C of the link CBD is pin-jointed to the link CE, which in its turn is pin-jointed at E to the arm EF, which is bolted to the band at F. To press the baskets against the elevator belt and prevent wobbling in transit, the linkage is arranged so that when the cradle is travelling vertically the upper portion CBDA is inclined at an angle of approximately 20° to the horizontal. The lengths of the various links on this elevator are :

AB	...	9 $\frac{1}{4}$ "
CB	...	17"
CD	...	22 $\frac{1}{2}$ "
CE	...	32 $\frac{1}{2}$ "
EF	...	15 $\frac{3}{4}$ "

The elevator is supported on a lattice steel tower secured to the basement floor. The band is of fine cotton and rubber and is 2 ft. wide and $\frac{1}{2}$ in. thick ; the speed of the band is 70 ft. per minute. its length is 70 ft. and the actual lift of the elevator is 28 ft. A straightforward type of screw tension gear for taking up stretch of the belt and adjusting the alignment is provided at the lower drum. There are eight cradles attached to the elevator band.

As already stated, the vertical elevator discharges on to a horizontal band conveyor, and to get a smooth discharge the take-away chains which provide the link between the elevator and the horizontal band conveyor must run at a higher speed than the conveyor band. The take-away chains can be seen in Fig. 4, and on this elevator they run at 144 ft. per minute, whereas the horizontal band conveyor runs at 130 ft. per minute. The take-away chains have an adjustment to enable the end nearest the elevator to be raised or lowered with respect to the end nearest the conveyor, which is fixed at $\frac{1}{2}$ in. above the conveyor belt. Actually, the chains on this elevator are set horizontally.

Two sizes of wicker basket are used for containing the mail, viz :—

25 in. square by 21 $\frac{1}{2}$ in. deep for packets and bags,

and 25 in. square by 11 in. deep for faced letters ; the weight of the larger and smaller baskets when fully loaded is 110 lbs. and 76 lbs. respectively.

The baskets are fitted with two sets of wooden battens along the bottom to serve as runners and so enable them to be easily pushed on to the loading platform.

Loading Platform.

The loading platform is shown in Fig. 5. A number of 3 in. diameter steel rollers, each 2 ft. long spaced 4 in. apart with a rise of 1 in 6, provide a ramp up which the baskets are fed on to the conveyor. The wooden runners on the bottom of the baskets align with the fixed "fingers" (consisting of narrow rollers clearly visible in Fig. 5) on which the basket rests. Presently the cradle fingers rise between the fixed fingers, as can be seen from the illustration, and lift

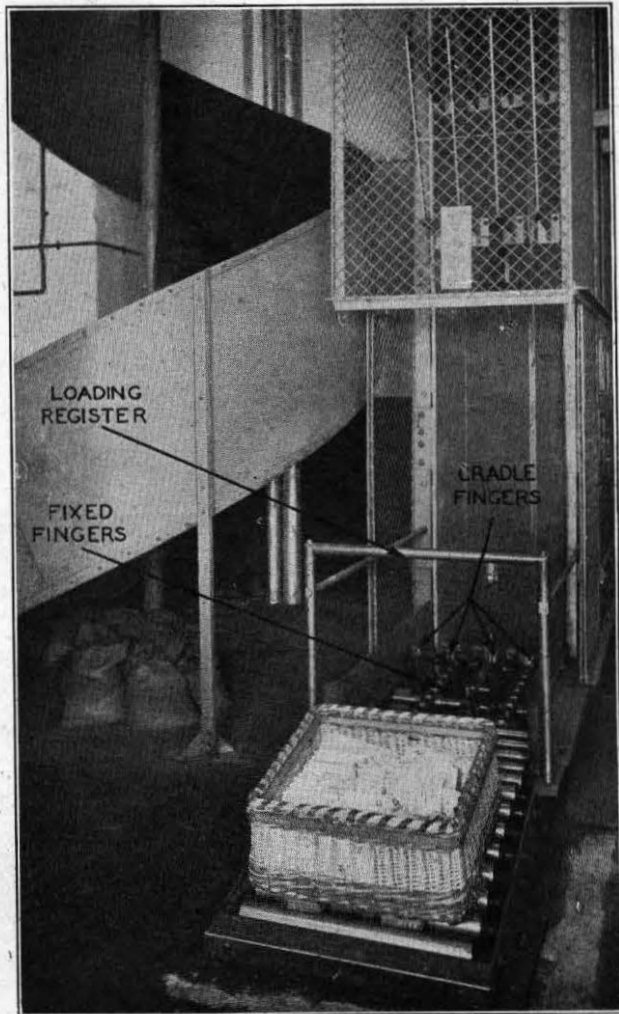

FIG. 5.—LOADING PLATFORM.

the baskets off the platform. Also shown in the photograph is the horizontal bar fitted as a "loading register" to prevent any baskets filled to a greater height than 27 in. from being pushed on to the elevator.

Some form of mechanical interlock on the feeding platform was necessary to guard against two dangers.

- (a) Baskets being pushed on to the fixed loading fingers before the previous cradle has moved sufficiently far away to prevent the basket or any of its contents fouling the lower arms EF of the cradle.
- (b) To prevent baskets being pushed on to the fixed loading fingers when the oncoming cradle is too close to the underside of the fixed loading fingers. If such a result were possible, it would be extremely likely that baskets would be raised when only half-way on to the cradle, and over-balance and crash to the floor.

The device adopted is shown in Fig. 6, and consists of a very robust spring-loaded cam-operated pin stop. Cam 1 operates the bell crank levers 2 and 3, compressing the spring between them and lowering the

stop, the lower end of which is of latch form. This end engages with the retaining latch 4, which with its spring and bell crank lever 5 are free. The stop is held down by the retaining latch 4 until the second cam 6 operates the bell crank lever 5 and releases the latch end of the stop. The spring of the stop levers 2

Signalling.

The starter is the usual heavy duty type contactor switch remote controlled by push buttons. The elevator and the horizontal band conveyor which it feeds are of course interlocked so that the elevator cannot be started without the conveyor and, when stopping, a time lag of 39 secs. is introduced to ensure that all baskets are cleared before the conveyor band stops.

A green signal lamp, which lights when the conveyor is started and remains alight so long as the conveyor is running, is provided at each discharge point. A green signal lamp is also provided at the loading platform to indicate that the horizontal band conveyor has started and is running. Emergency stop buttons are provided at a number of selected points to enable the elevator and conveyors to be quickly shut down in case of necessity.

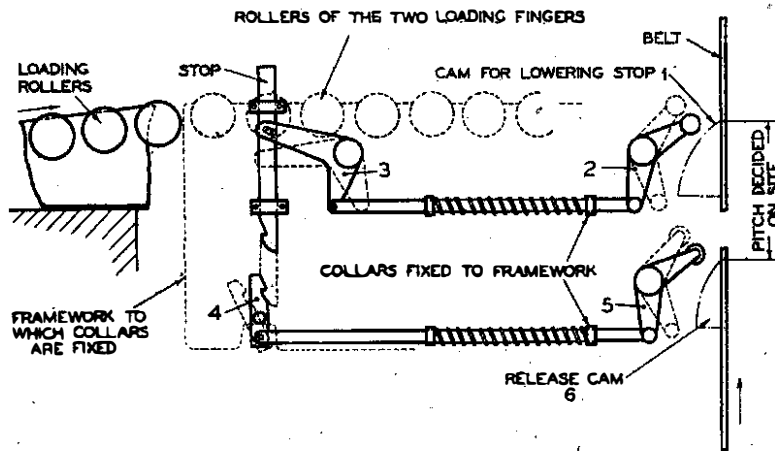

FIG. 6.—MECHANICAL INTERLOCK ON LOADING PLATFORM.

and 3 which had previously been compressed by the movement of cam 1 immediately raises the stop into the position shown in Fig. 6. The lowering and raising cams and their respective levers are fitted on opposite sides of the centre line of the belt.

The interval of loading, i.e. the pitch of the cams 1 and 6, has been made as long as possible consistent with a good reserve capacity for peak-load periods, and was determined experimentally on site.

The interlock has worked very satisfactorily in practice.

The motor driving the elevator is of 6 B.H.P., running at 750 R.P.M., and drives a worm wheel reduction gear with a ratio of 30 to 1. The elevator drum and the take away chains are driven by chain and sprocket gear from the worm wheel.

Conclusion.

This elevator was of a somewhat experimental nature because it had to stand up to much heavier duty than the standard type manufactured by the makers for use in newspaper publishing rooms. These types usually have two to three linkage members per cradle instead of the four which have been provided on this installation, and further modifications in design were also necessary to fulfil Post Office requirements. The elevator has proved very satisfactory in performance, and the stability of the cradles and the smoothness of the discharge on to the horizontal conveyor have been exceptionally good. Little maintenance attention beyond greasing of bearings and occasional taking up of tension on the band has been necessary.

The horizontal conveyors and spiral chute were provided by Sovex Ltd.

TELEPHONE AND TELEGRAPH STATISTICS—SINGLE WIRE MILEAGES AS AT MARCH 1943 THE PROPERTY OF, AND MAINTAINED BY, THE POST OFFICE

REGION	OVERHEAD			UNDERGROUND		
	Trunks and Telegraphs	Junctions	Subscribers *	Trunks and Telegraphs †	Junctions ‡	Subscribers ¶
Home Counties	14,989	44,764	301,885	1,236,386	277,245	1,243,580
South Western	9,012	40,070	230,807	575,729	118,801	678,133
Midland	8,940	28,693	193,280	803,230	285,149	980,404
Welsh & Border Counties	9,054	25,533	131,938	419,175	69,745	272,597
North Eastern	12,064	24,934	160,442	676,573	211,216	935,960
North Western	1,982	8,733	107,812	538,962	338,486	1,149,247
Northern Ireland	9,392	8,572	30,002	94,625	34,143	118,409
Scottish	23,784	34,206	173,573	595,267	197,108	726,781
Provinces	89,217	215,505	1,329,739	4,939,947	1,531,893	6,105,111
London	677	1,539	71,737	721,775	1,586,037	3,672,378
United Kingdom	89,894	217,044	1,401,476	5,661,722	3,117,930	9,777,489

* Includes all spare wires.

† All wires (including spares) in wholly M.U. Cables.

‡ All wires (including spares) in wholly Junction Cables.

¶ All wires (including spares) in Sub's. and mixed Junction and Sub's. Cables.

Measurements on High-Frequency Cables and Feeders

R. F. J. JARVIS, Ph.D., and
J. C. SIMMONDS, Ph.D.

Part I. Tuned Circuit Substitution Methods

U.D.C. 621.317.33 : 621.315.2

This part deals mainly with the methods of determining the propagation content and characteristic impedance of samples of cable by measuring the damping effects they produce when included in tuned circuits.

Introduction

DURING the past decade high-frequency cables have been used to an increasing extent by the Post Office, and many hundreds of miles have been laid. The introduction of these cables has meant that high-frequency measuring technique has had to be improved, and in some cases special methods devised. When measurements were first made by the Post Office on high-frequency cables, high-frequency measuring technique had not reached a very advanced stage; in fact, the rapid development which has taken place during the past decade was probably due to the introduction of the high-frequency cable and the consequent need for more accurate measurements. The apparatus described was designed during this period of rapid development and is not, therefore, always the best form now available. It has, however, been in use over a period of years, and has given satisfactory results.

MEASUREMENTS USUALLY MADE ON HIGH-FREQUENCY CABLES

The various types of measurement usually made on high-frequency cables are enumerated below:—

1. The open- and closed-circuit impedances of a short length of cable. By "short," a length not greater than about one-eighth of a wavelength is implied.
2. The open- and closed-circuit resistances on lengths of cable which are a multiple of one-quarter of a wavelength long.
3. Characteristic impedance and input impedance.
4. Insertion loss and insertion phase shift.
5. Cross-talk attenuation.
6. Fault localisation.
7. Impedance irregularities.

From the open- and closed-circuit impedances of a short length of cable it is possible to calculate the primary and secondary constants of the cable, either by the exact methods given in text books,¹ or by approximate methods.^{2, 3}

It can be shown that the open- and closed-circuit impedances of cables at certain frequencies, called resonance frequencies, are pure resistances and that at these frequencies the electrical length of the cable is a multiple of a quarter of a wavelength.⁴ From the open- and closed-circuit resistances the characteristic impedance and the attenuation can be found; also from the resonance frequency and a

knowledge of the approximate velocity of phase propagation the actual velocity of phase propagation can be calculated. The theory of the method depends upon the fundamental assumption that the characteristic impedance is a pure resistance; this assumption is not always justified, but formulæ which give the errors likely to be introduced have been given.⁵ Insertion loss is usually measured by applying a fixed voltage to an impedance A connected in series with an impedance B. If the voltage which appears across impedance B is V_1 when impedance A is connected directly to impedance B, and V_2 when the cable is inserted between them, then the insertion loss of the cable between impedance A and impedance B is $20 \log_{10} V_1/V_2$ db.

The measurement of insertion phase shift has been dealt with elsewhere⁶ and will not be considered in the present paper.

It should perhaps be pointed out that apparatus designed for measurements on cables generally has a much wider field of application. Thus, apparatus designed for open- and closed-circuit measurements on short lengths of cable is also suitable for measurements on components. Apparatus designed for measurements on cables at resonance frequencies is also suitable for measurements on resistors and generally for other impedance measurements. Apparatus designed for measurement of insertion loss or phase shift of cables is equally suitable for such measurements on any four-terminal network. Thus, although the apparatus and measuring methods dealt with below are described with particular reference to cable measurements, it should be borne in mind that they have a wide variety of other uses.

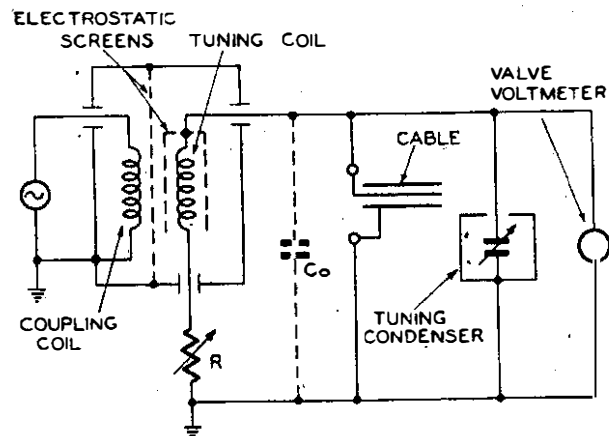

FIG. 1.—BASIC CIRCUIT OF TUNED CIRCUIT, SERIES RESISTANCE, SUBSTITUTION METHOD.

¹ "Outline Notes on Telephone Transmission Theory," W. T. Palmer, p. 134.

² *J. Sci. Insts.*, 1942, No. 4, p. 53.

³ *Phil. Mag.*, 1942, p. 688.

⁴ "Communication Engineering," Everitt, Chapter V.

⁵ *Phil. Mag.*, 1942, p. 904.

⁶ *P.O.E.E.J.*, 1941, p. 162.

TUNED CIRCUIT, SERIES RESISTANCE, SUBSTITUTION METHOD OF MEASUREMENT OF IMPEDANCE

In this method, which has been developed for measurements on short lengths of cable over the frequency range 100-4,000 kc/s, the capacitance of the unknown impedance is determined by the necessary change in the tuning condenser of a resonance circuit when the unknown impedance is connected across the circuit. The resistive component of the

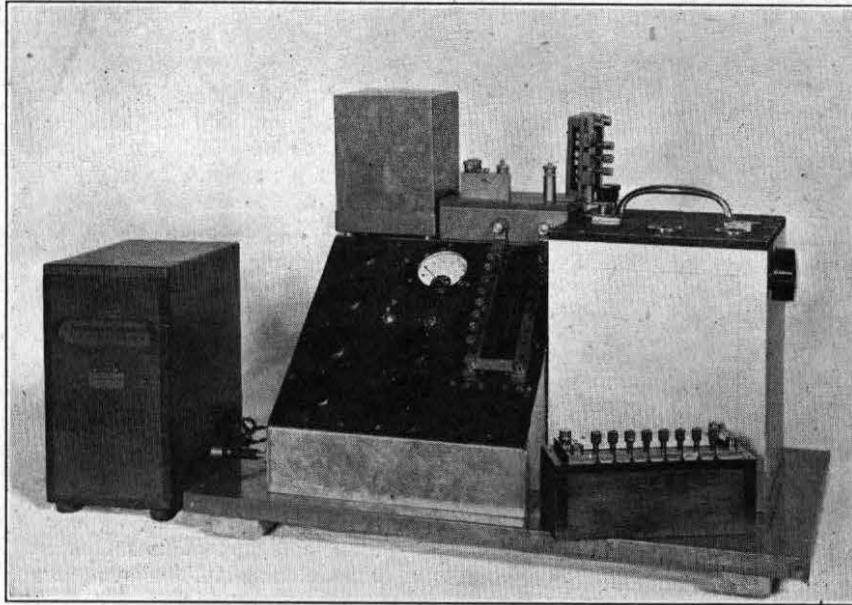

FIG. 2.—TUNED CIRCUIT, SERIES RESISTANCE, SUBSTITUTION APPARATUS.

impedance is calculated from the change in the series resistance required to damp the circuit to the same extent as the addition of the impedance. Fig. 1 shows the basic circuit of the apparatus⁷, a photograph of the latest form of the apparatus being shown in Fig. 2. Two of the constant inductance resistance boxes referred to below may also be seen in this photograph. A slide-back valve voltmeter with a "backing-off" circuit and galvanometer is employed as a resonance indicator because of its great sensitivity to small percentage changes in input voltage. Resistance can be inserted in series with the tuning inductance by the plug type resistance box R, the inductance of which is constant⁸. Constant inductance is obtained by constructing each resistance element of a loop of eureka wire and a loop of copper wire, of equal inductance, connected in series. By shorting a copper loop and bringing a eureka loop into circuit, the resistance can be changed by a known amount while the inductance remains constant. To reduce the number of positions necessary in the box, and so reduce the total inductance and capacitance of the box to a minimum, the increments of resistance increase geometrically. This, of course, makes the box less convenient to use. Two such resistance boxes have been found to cover all requirements. One box has a maximum value of 2.55 Ω , and the other a maximum value of 12.75 Ω . Similar boxes

⁷ P.O.E.D. Radio Report No. 566.

⁸ P.O.E.D. Radio Report No. 453.

are now being manufactured commercially. From the measured series inductance and parallel capacitance of the boxes it is estimated that their H.F. resistance is within + 0.5 per cent. of the D.C. resistance at 5,000 kc/s. The resistance box could be placed in other positions, but the one shown is thought to be the best and has the following advantages:—

(a) The resistance box is shunted only by its own earth capacitance. If it were connected in series with the main tuning condenser in the low potential side, it would be shunted by the earth capacitance of the condenser screen.

(b) It is free from effects of hand capacitance. If it were connected in series with the tuning condenser on the high potential side, it would require double screening.

(c) The absolute value of the circuit resistance is not required but only its changes in value. The absolute value of the effective inductance of the resistance box does not matter in this position providing it is independent of the amount of resistance in the box. This condition is achieved as explained above by the

special construction of the box.

To obtain accuracy in the final result, the residual inductance and resistance of the tuning condenser, which is of precision type, must be known and corrected for and can conveniently be determined by the method described below. Actually a 0.750 $\mu\mu\text{F}$ condenser is used with plug type, silvered mica, condensers to extend the maximum capacitance to 4,250 $\mu\mu\text{F}$. It is, of course, essential to correct for the residual parameters of these fixed condensers, but they can be found once those of the 0.750 $\mu\mu\text{F}$ condenser are known.

The capacitive component of an impedance is simply given by the change in the tuning condenser necessary to restore resonance when the unknown impedance is connected across the circuit, providing no change is made in the resistance box setting while this operation is being performed. To determine the resistive component of the impedance the following procedure must be carried out. With the unknown impedance connected across the circuit, the tuning condenser is adjusted to give resonance and the reading of the valve voltmeter noted. After disconnecting the impedance, resonance is restored and the voltmeter brought to its previous value by inserting resistance in the plug-box. If it is not possible to bring the voltmeter exactly to the original reading, the meter scale can be used for interpolation. If the unknown impedance is $R_x - j/\omega C_x$,

$$R_x = \frac{R_b}{C_x^2} (C_o + C)^2$$

where R_b is the change in the resistance box.

C_x is the capacitive component of the unknown.

C_o is the total stray capacitance to earth (see Fig. 1).

C is the capacitance in the tuning condenser when the unknown is connected.

This expression is an approximation, and if the power factor of the total capacitance of the circuit, including the unknown, is large, errors are introduced due to the difference between voltage and current resonance⁹. However, if this power factor is less than 0.15 the error is less than 1 per cent., so that almost invariably this error is quite negligible. It will be observed that C_o enters into this expression. For this reason, the tuning coil is screened in such a manner that the coil size does not affect C_o (see Fig. 1).

Since the input impedance of a close-circuited cable is inductive and of low value it cannot be connected directly across the tuned circuit. When close-circuit measurements are to be made on cables it is, therefore, necessary to measure them in series with a small fixed condenser, the capacitance and resistance of which can be determined by a separate measurement, and then to calculate the inductance and resistance from the apparent change in capacitance and resistance of this condenser due to the introduction of the cable.

As previously stated, to obtain accuracy at the higher frequencies of the range it is necessary to apply corrections for the power factor and inductance of the tuning condenser. If at any one frequency the condenser loss can be represented by a constant series resistance, regardless of the setting, and, if the inductance can also be regarded as independent of the setting, these two quantities can be found from simple observations on the tuned circuit apparatus. The method has been described in the technical press^{10, 11} since it was first used in the Post Office, but a brief description will be given here as it does not appear to be very well known. To determine the inductance, a small fixed condenser of capacitance C_m and resistance R_m is connected across the tuning condenser, which is adjusted to give resonance. Let the value of capacitance required be C_1 . The fixed condenser is then removed and the tuning condenser increased to, say, C_2 , so that resonance is again attained. In these circumstances the inductance L of the condenser is given by the relation:—

$$C_2 - C_1 = C_m - \omega^2(C_2^2 - C_1^2) L$$

where $\omega = 2\pi \times \text{frequency}$.

By repeating the above procedure at the same frequency but at different settings of the tuning condenser it is possible to plot values of $(C_2 - C_1)$ against values of $\omega^2(C_2^2 - C_1^2)$. Providing the assumption that L is independent of condenser setting is justified, the curve obtained is a straight line whose slope is equal to L .

The series resistance, R_x , of the tuning condenser may be found in an almost identical way. First the

circuit is tuned to resonance as before and then the fixed condenser is removed and the circuit retuned. Now, however, the additional resistance, R_b , say, is inserted so as to damp the circuit to the same extent as the fixed condenser. Then,

$$(C_o + C_2)^2 R_b = C_m^2 R_m - (C_2^2 - C_1^2) R_x$$

Again, by repeating the measurement at different settings of the condenser and plotting the values of $(C_o + C_2)^2 R_b$ against $(C_2^2 - C_1^2)$, a graph can be drawn, which is a straight line if R_x is independent of condenser setting, from which R_x can be found.

Apparatus built on the lines outlined above has been in almost constant use during the last eight years for measurements on short lengths of cables and also for measurements of capacitance, inductance, resistance and power factor at frequencies up to 4 Mc/s. The accuracy obtained depends upon the quantity being measured, but, when all the necessary corrections are applied, is such that all the primary and secondary constants of a short length of cable can be found, with an error less than ± 2 per cent, and some of the constants with a much better accuracy than this. The errors were estimated in the first instance but have since been checked by measurements on different lengths of the same cable. A very good check on cable measuring apparatus can be obtained by making measurements on different lengths of the same cable, because the quantities to be measured on the different lengths are quite different but, providing the cable is uniform, the corresponding constants calculated from these quantities should be equal.

TUNED CIRCUIT, PARALLEL RESISTANCE, SUBSTITUTION METHOD OF MEASUREMENT OF RESISTANCE

This method was devised for measurements at resonance frequencies on lengths of balanced cable, and has been used satisfactorily at frequencies as high as 50 Mc/s. The reactance variation method mentioned later, if built in balanced form would, it is thought, be more reliable and the range of resistance measurement would be less restricted, but it would be a good deal more costly and also less robust. The method about to be described can be recommended as long as it is used intelligently by an operator who

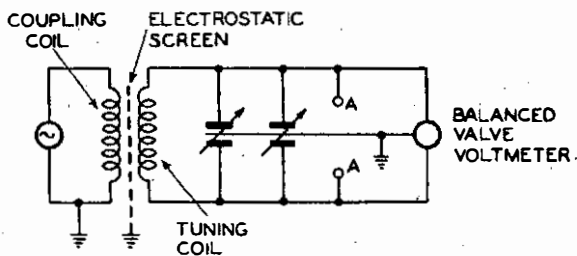

FIG. 3.—BASIC CIRCUIT OF TUNED CIRCUIT, PARALLEL RESISTANCE, SUBSTITUTION METHOD.

appreciates its limitations. Fig. 3 shows the basic circuit, which consists simply of a balanced tuned circuit, with an earth on the centre point of the tuning condenser but not on the coil. This circuit is excited by a coupling coil from which it is electrostatically screened. A balanced voltmeter is used to indicate the voltage produced across the tuned circuit and

⁹ "Radio-Frequency Measurements," L. Hartshorn, p. 24.

¹⁰ Proc. I.R.E., 1936, p. 253.

¹¹ Wireless Engineer, June, 1940, p. 257.

consists of two anode-bend rectifiers, one having a reflecting galvanometer and "backing-off" arrangement in its anode circuit.

Resonance frequencies of the cable to be measured are found in a manner similar to that described later in connection with the reactance variation method. Having found the resonance frequency, the cable is connected across the circuit and the resonance voltage reading on the galvanometer noted. The cable is then replaced by a solid carbon composition type resistor of value such that the voltmeter reading is approximately equal to the initial reading. Another value of resistance is then found so that a reading on the other side of the initial reading is obtained. Then, by interpolation, the resistance of the cable at resonance can be found. To check the validity of linear interpolation and also to check that one of the resistors has not some high frequency fault, it is advantageous to use three or even four resistors. Resistors of the type suggested for use vary appreciably with weather conditions, but this is immaterial because the D.C. resistance can be measured directly after an H.F. measurement has been made, and the D.C. and H.F. values taken as equal. Owing to distributed capacitance along the resistors, the H.F. resistance tends to be lower than the D.C. value^{12, 13} but so long as the frequency and the resistance value are not too great the difference is negligible. The probable error can be estimated, however, and providing care is taken the results obtained are reliable. Measurements made by this method and also by other methods are shown in

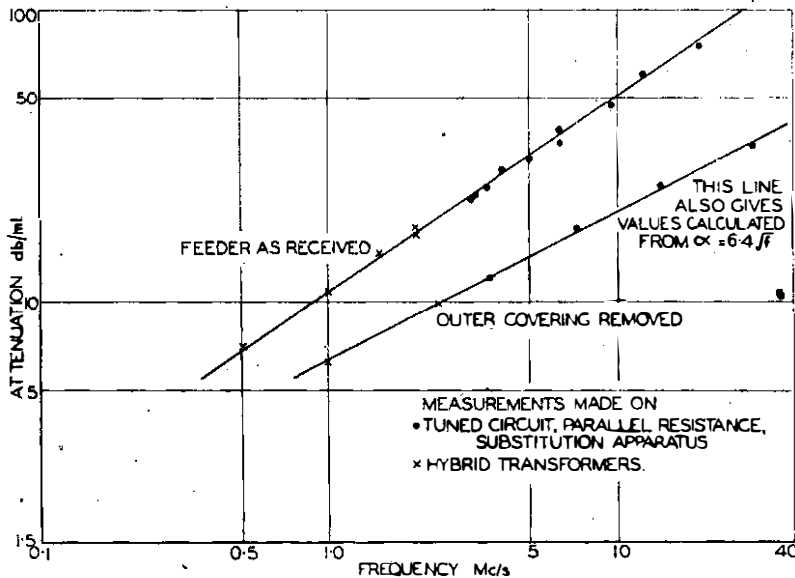

FIG. 4.—UNSHIELDED TWIN FEEDER ATTENUATION CHARACTERISTICS.

Fig. 4. This particular feeder was of considerable interest because the polythene, used to separate the two conductors, was covered by several layers of inferior dielectric material. Removing these layers effected a great decrease in the attenuation, as shown in the figure. No other method is at the moment

available to obtain check measurements at the higher frequencies, but check measurements with other methods at lower frequencies and measurements on different lengths of the same feeder indicate that the errors are not greater than ± 3 per cent. even at 50 Mc/s.

REACTANCE VARIATION METHOD OF MEASUREMENT OF IMPEDANCE

The reactance variation method of resistance measurement is widely used and has an extensive literature.¹⁴ Since the resistance is measured in terms of a capacitance, which can usually be determined very accurately even at quite high frequencies, the method is suitable for use at high frequencies. Apparatus employing this principle, but specially designed for dielectric power-factor measurements at frequencies up to 100 Mc/s, has been described by Hartshorn and Ward.¹⁵ This circuit has since been

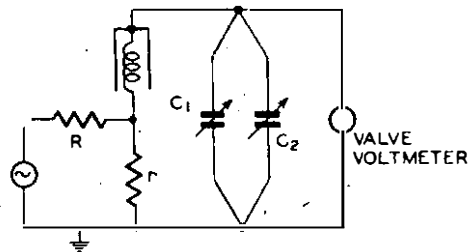

FIG. 5.—REACTANCE VARIATION CIRCUIT, 5-50 Mc/s.

used for measurements on coaxial cables and feeders.¹⁶

Fig. 5 shows the basic circuit and Fig. 6 a photograph of apparatus operating upon this principle but specially designed for measurements on coaxial cables at frequencies up to 50 Mc/s. From the circuit diagram it will be observed that the "Q meter" method of feed is used. This has the advantage that no coupling coil is required but has the disadvantage that a large current is required from the exciting oscillator because the resistance 'r' must be kept small. Two variable condensers are included in the apparatus. One, which has a maximum capacitance of about 150 $\mu\mu\text{F}$, is used to tune the circuit to resonance at the operating frequency, and is constructed to have as low a series inductance and resistance as possible. The other has a maximum capacitance of about 15 $\mu\mu\text{F}$ and consists of a micrometer plunger arranged to screw into the fixed member of the larger condenser. This condenser is

used to measure the reactance variation. An anode bend detector is used to indicate the voltage developed across the tuned circuit and a special calibrating circuit, supplied from a 1,000 c/s stabilised oscillator of good waveform, is included so that the indicator can be calibrated to a voltage equal

¹² *Wireless Engineer*, 1935, p. 291, and 1940, p. 471.

¹³ *Wireless Engineer*, 1938, p. 363.

¹⁴ *Proc. I.R.E.*, 1938, No. 12, p. 1466.

¹⁵ *J.I.E.E.*, 1936, p. 597.

¹⁶ *J.I.E.E.*, 1942, p. 213.

to $1/\sqrt{2}$ of the resonance voltage developed across the circuit. From the difference in the two values of tuning capacitance in the circuit at which the voltage across the circuit is reduced to $1/\sqrt{2}$ of the voltage at resonance, the equivalent loss resistance of the circuit can be determined.

Obviously the value of any unknown resistance can be determined by finding this equivalent loss

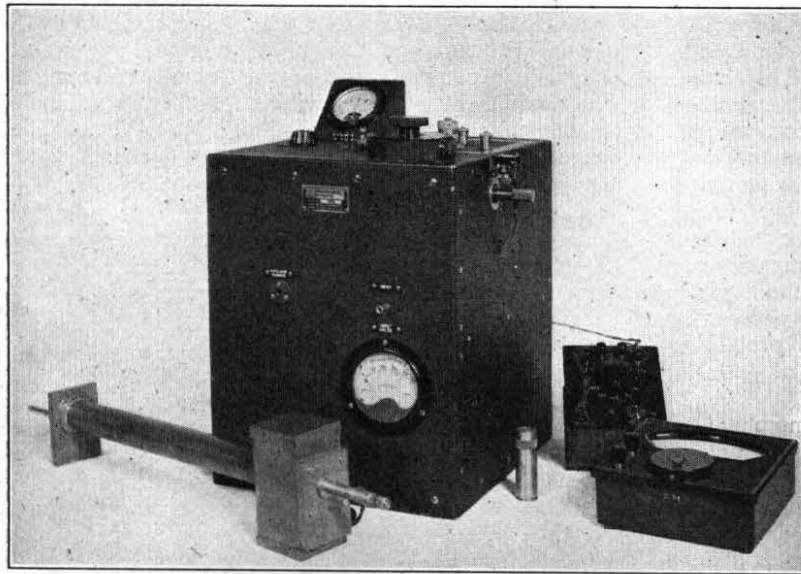

FIG. 6.—REACTANCE VARIATION APPARATUS. 5-50 Mc/s AND 50-250 Mc/s.

resistance, first for the circuit alone and then with the resistance connected in parallel. The method is suitable only for fairly high values of resistance, which do not damp the circuit too much. Low resistances can be measured by connecting them in series with a small fixed condenser, whose constants are determined by a separate measurement, or, alternatively, the resistance can be connected in series with the tuned circuit. This latter method is not suitable for cable measurements. Between the high and low resistance values there is a range of values which are very difficult to measure by this method, for they are too small to connect directly across the circuit and too large to connect in series with any but a condenser so small that the effect of stray capacitance is appreciable.

It is often very useful to plot the expression $\sqrt{(V_r/V)^2 - 1}$ against capacitance in the apparatus, V_r being the voltage across the circuit at resonance and V the voltage at any other condition. The curve obtained is a straight line if the apparatus is working correctly and its slope is equal to ωR , R being the equivalent parallel resistance of the whole circuit.

Although this apparatus is capable of measuring the open- and closed-circuit impedances of a short length of cable, it is usually employed for resonance measurements on longer lengths of cable. The reason for this is that measurements made at resonance frequencies are no more difficult to perform than at other frequencies and the calculations necessary to obtain the attenuation and characteristic impedance are very simple. At low frequencies it is not always

possible to obtain sufficient cable to make resonance measurements, for at 100 kc/s about 750 yards of cable would be required. However, at the high frequencies for which this apparatus is intended the difficulty of length of cable required does not arise and, therefore, measurements at resonance frequencies are preferred.

Consider first the measurement of the cable when its input impedance is a high resistance. Although the frequency at which this will occur can be calculated with a fair degree of accuracy, it has to be found exactly as part of the measurement, and this requires a certain amount of skill on the part of the operator. The experimental procedure is to tune the apparatus to the estimated frequency and then to connect the cable across the circuit. If the cable behaves as a pure resistance no adjustment of the tuning condenser will be necessary to obtain the maximum voltage across the circuit. If any adjustment is required then the frequency must be altered slightly and the procedure repeated. Once the correct frequency is found, the measurement is exactly the same as for a resistance. When the input impedance of the cable is a low resistance it must be connected in series with a small condenser, as stated previously. In these circum-

stances the resonance frequency is such that no adjustment of the tuning condenser is required to give resonance when the cable is in circuit or when it is shorted out (providing the reactance of the condenser is much greater than the resistance of the cable) and the frequency must be adjusted until this condition is obtained. The resistance of the combination can then be determined as before and from this and the result of a separate measurement on the condenser the cable resistance can be found.

In making the separate measurement on the condenser, a fairly large change in the tuning condenser must be made when the condenser is removed from circuit and, therefore, to avoid errors, either the loss of the tuning condenser must be negligible or corrections must be applied. Because of this difficulty, usually only the high resistance values are determined and the characteristic impedance is assumed equal to the value at lower frequencies, where it can conveniently be measured by other methods. This assumption has been found to be justified, but the characteristic impedance must be measured at a sufficiently high frequency to allow the skin effects to become fully established. The attenuation can then be calculated from the very simple expression

$$\alpha = \text{Tanh}^{-1} \frac{Z_0}{R_{\max}} \text{ nepers,}$$

where α is the attenuation, Z_0 is the characteristic impedance at lower frequencies and R_{\max} is the high resistance of the cable at resonance. Measurements made on known resistors, on different lengths of the same cable and by other apparatus have shown that

resistances and attenuation can be measured at frequencies up to 50 Mc/s without the errors exceeding ± 2 per cent.

In addition to attenuation and resistance measurements the apparatus can be used to measure the phase constant of cables, from which the velocity of propagation can be calculated. To obtain these quantities it is necessary to determine only the resonance frequencies of the cable, for at these frequencies the phase delay is known to be an exact multiple of $\pi/2$. Thus, if the velocity of propagation is known approximately, the phase constant can be found and thence the exact velocity of propagation. The accuracy of this type of measurement depends upon the accuracy with which the resonance frequency can be found and measured, upon the impedances of the connecting leads and upon the impedances which are unavoidable at the end of the cable whether it is open- or close-circuited. Measurements have been made on low-loss cables, the resonance frequencies of which are very sharply defined, by this method, with an estimated error of the order of ± 0.1 per cent. If great care were exercised it appears probable that the error could be reduced to the order of ± 0.01 per cent.

The apparatus as constructed at the moment is suitable for measurements on coaxial cables only, but the method appears to be eminently suited for balanced cable measurements because all the components necessary can readily be made in balanced form, and a balanced form of the apparatus is being developed.

THE APPLICATION OF THE REACTANCE VARIATION METHOD TO HIGHER FREQUENCIES

The form of apparatus just considered cannot be applied to very high frequencies, and probably the limit is not greater than 100 Mc/s. The main reason for this is that the linear dimensions of the circuit elements become an appreciable fraction of a wavelength at higher frequencies, and consequently "lumped" circuit theory cannot be applied. Various methods have been evolved for measurements at higher frequencies^{17, 18}, but these involve the use of transmission lines and are not really suitable for use below about 250 Mc/s because of the large dimensions of the lines required. By reducing the size of the reactance-variation equipment, particularly the

dimensions of the condenser, it is possible to increase the maximum frequency to over 200 Mc/s, and thus to overlap the frequency range made possible by transmission line methods. Actually a variable condenser of very small dimensions has been described with which it is claimed reliable measurements can be made at frequencies up to 300 Mc/s.¹⁹

Apparatus has been developed by the Post Office on the above lines for the measurement of resistances at frequencies from 50 to some 250 Mc/s. This was achieved by replacing the tuning inductance by a coaxial transmission line of adjustable length and the tuning condenser by a very small micrometer condenser formed by screwing a plunger into a hole in the inner conductor of the coaxial line. The overall dimensions of this condenser are less than

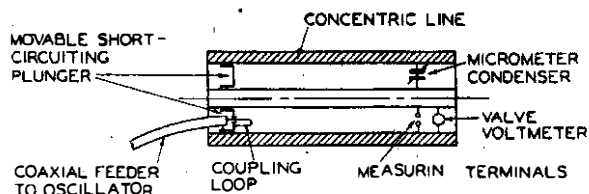

FIG. 7.—REACTANCE VARIATION CIRCUIT. 50-250 Mc/s.

2 cm. A diagrammatic arrangement is given in Fig. 7, the apparatus being at the front of Fig. 6.

Current is fed through a small loop near the short-circuited end of the line to provide the excitation, and the voltage developed across the condenser is measured by a diode valve voltmeter. In this apparatus the voltmeter has been made to give an indication very nearly proportional to the peak voltage, and this avoids the calibrating necessary with the apparatus described previously. The apparatus is operated in just the same way as the lower frequency apparatus and, apart from the fact that it is rather more difficult to find the resonance frequencies, the operation is just as simple. Measurements made with this apparatus on known resistors, on different lengths of the same cable and by other apparatus at lower frequencies indicate that resistances and attenuation can be measured with an error less than ± 5 per cent. at frequencies at least up to 200 Mc/s.

With some cables it is possible, of course, to connect the variable condenser directly across them, and feed the circuit thus formed by stray coupling from the oscillator. This avoids the use of the adjustable line and the losses it introduces.

¹⁷ *J. Applied Physics*, 1939, p. 27.

¹⁸ *Hoch. u. Elek.*, 1939, p. 61.

¹⁹ *R.C.A. Review*, 1938, p. 156.

Emission-Type Photo-Electric Cells

U.D.C. 621.383

A. C. LYNCH, M.A., and
J. R. TILLMAN, Ph.D.

The performance of emission-type photo-electric cells is described, and circuits are given for their use for measurement of light intensities, for operation of triggering devices, and for reproduction of sound-film.

Introduction.

THERE are three types of device, all known as "photo-electric cells," in which light¹ produces electrical effects. They are:

- (1) The "conductivity" cell, the resistance of which is reduced by incident light;
- (2) The "barrier-layer" cell, which generates an E.M.F. when light falls on it;
- (3) The "emission" cell, in which electrons are released from a metal surface (the cathode) by the light.

Selenium cells belong to one or other of the first two classes.

Conductivity cells are comparatively slow in response, and sometimes erratic in performance.

use with amplifiers or for the measurement of very weak sources of light; for these purposes emission-cells are greatly to be preferred, and this article is confined to the characteristics and methods of use of this type of cell.

In an emission-type cell the electrons released from the cathode are collected by a second electrode (the anode) maintained at a positive potential by an external supply. The currents so obtained are very small, and for many purposes amplification within the photo-electric cell is desirable. The following types of emission cell have consequently been developed:—

(a) The "vacuum" cell, in which the liberated electrons are collected directly;

(b) The "gas-filled" cell, in which the electrons, accelerated by the applied voltage, ionise, by collision, molecules of a gas—usually argon—which is present at a suitable low pressure. These ions are formed in pairs: one electron and one molecule from which the electron was detached, and which therefore carries a unit positive charge (equal and opposite to that of an electron). In this type of cell, one electron emitted from the cathode may result in the collection at the electrodes of perhaps five pairs of ions, and therefore, including the primary electrons, six times the current obtainable in a vacuum cell.

(c) The "secondary-emission" cell, or "electron multiplier." This is a vacuum cell in which the primary electrons, after being accelerated, bombard the surface of an intermediate electrode. The material of this electrode is chosen to be one which emits up to 8 or 10 secondary electrons for each primary electron incident on it. This process can, if desired, be repeated at a number of surfaces in succession.

In appearance and dimensions (Fig. 1) these cells are generally similar to thermionic valves; they frequently have the same types of base and holder.

CHARACTERISTICS

Electrical Equivalent.

An emission-type photo-electric cell is equivalent to a high-impedance (and therefore constant-current) source, shunted by the inter-electrode capacitance of the cell, of the order of $5 \mu\mu\text{F}$ in a typical commercial cell. It would be possible to reduce this capacitance by increasing the separation of the electrodes; but in general this process would not improve the per-

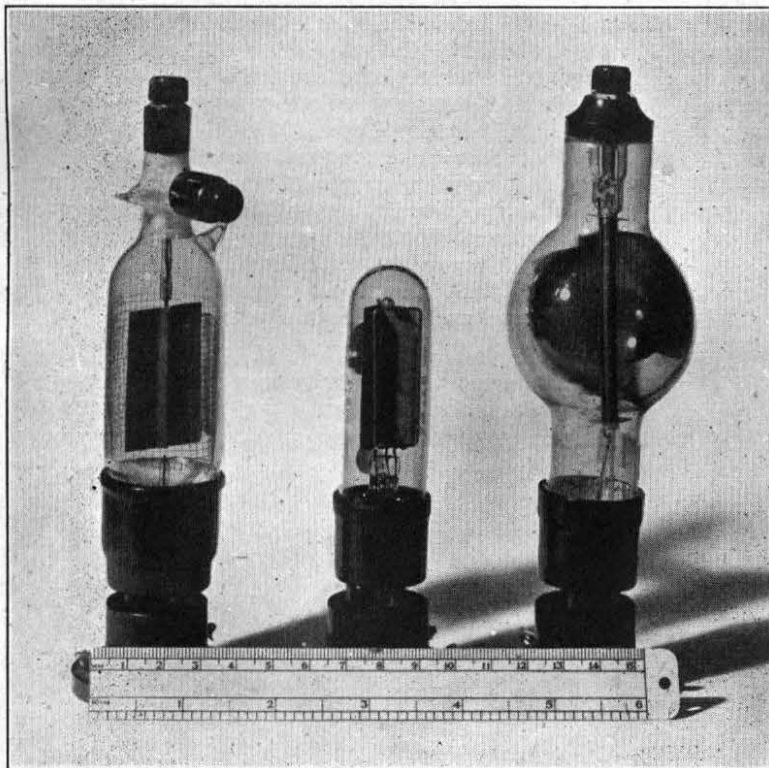

FIG. 1.—VACUUM GAS-FILLED SECONDARY-EMISSION PHOTO-CELLS. TYPICAL COMMERCIAL TYPES.

They are used for burglar alarms, for control of artificial lighting, and for slow counting of moving objects. For quantitative work, however, they are obsolete. Barrier-layer cells are in extensive use for photographic exposure meters and for "foot-candle" meters. They are not, however, very convenient for

¹ Photo-electric cells, unlike bolometers and thermopiles, are insensitive to radiation of wavelength much longer than that of visible light. They are insensitive to radiant heat as such.

formance of the cell at high frequencies owing to transit-time effects.

Sensitivity.

The sensitivity of a cell is expressed in μA per lumen. (1 lumen is the total amount of light falling on a surface of 1 sq. ft. at a distance of 1 ft. from a source of 1 candle-power.) This figure for the rating of the cell does not depend on the size of the sensitised cathode, for an increase of cathode area will increase the amount of light (measured in lumens) collected. The sensitivity of a "caesium" cathode, the commonest in commercial use, is about $15 \mu\text{A}$ per lumen; most others are less sensitive, but a cathode has recently been produced for which a sensitivity of $50 \mu\text{A}$ per lumen is claimed. Owing to the selective colour-response of cathodes it is necessary to specify the colour-characteristics of the light with which the measurement is made; this is equivalent to fixing the temperature of the lamp-filament used. The generally adopted standard is an incandescent lamp at a temperature of $2,850 \text{ deg. K.}$; this is advantageous in being the type of source with which photo-electric cells are frequently used. Sensitivities quoted in this article refer to this type of light. The sensitivity to daylight is, unfortunately, not capable of accurate measurement, owing to the wide variation of colour of daylight. The sensitivity of an ordinary "caesium" cathode is from 4 to $8 \mu\text{A}$ per lumen of daylight instead of the $15 \mu\text{A}$ per lumen of the light from an incandescent lamp.

In gas-filled and secondary-emission cells the sensitivity is greater; for example, using the above-mentioned cathode giving $15 \mu\text{A}$ per lumen in a gas-filled cell, a sensitivity of $75 \mu\text{A}$ per lumen is obtained. A one-stage secondary emission cell using this cathode will give $200 \mu\text{A}$ per lumen, and sensitivities up to 2A per lumen are obtainable in experimental multi-stage electron-multipliers.

In practice, damage to the cell may result from attempts to draw currents corresponding to illuminations greater than, say, $\frac{1}{10}$ lumen.

The sensitivity of an emission cell usually depends on the polarising voltage applied to it. (Fig. 2.) That of a vacuum cell, however, is substantially

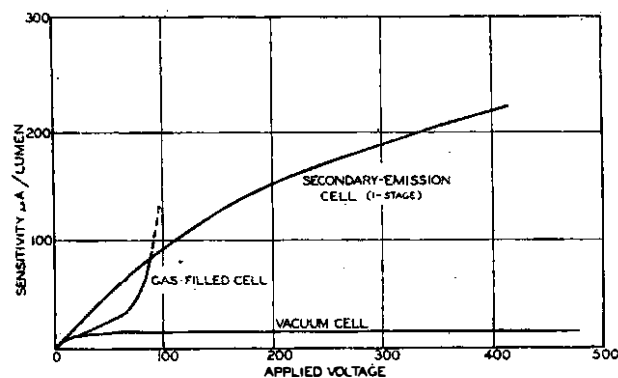

FIG. 2.—VARIATION OF SENSITIVITY WITH APPLIED VOLTAGE.

independent of voltage when the voltage exceeds about 20; this condition is known as saturation, and is very desirable for accurate quantitative work.

The sensitivity of a secondary-emission cell is at a maximum at a voltage of the order of 500 per stage, and is fairly good at 100 to 150 V per stage. If the potential applied to a gas-filled cell be increased, the sensitivity rises steadily at low values of this potential; then, as a certain value of the order of 100 V is approached, the increase becomes very rapid. At potentials higher than this value a glow discharge is maintained in the gas independently of the incident light. The curves of Fig. 2 represent the behaviour of the three types of cell, assuming the same type of cathode in each case.

Linearity of Response.

The vacuum cell, when used under saturation conditions, gives an accurately linear response over a wide range of values (10,000 : 1) of incident illumination. The secondary-emission cell, being essentially a vacuum cell, is nearly as good. The gas-filled cell, though inferior, gives a substantially linear response except when used with high polarising voltages or high illuminations.

Dark Current.

The cathode material usually emits electrons at a small rate even in the dark; this is simply thermionic emission. This dark-current is largest in caesium cells; a better ratio of sensitivity to dark-current is obtained with other cathodes (e.g., potassium) which are therefore used, in spite of their lower sensitivity, for some precision measurements.

Unless, however, a guard-ring is used between anode and cathode there will be a leakage current over the insulation which greatly exceeds the thermionic dark-current; e.g., 10^{-9} A leakage current compared with thermionic currents of 10^{-11} A in a caesium cell and 10^{-13} A in a potassium cell.

Colour Response.

Approximate curves for various cathodes are given in Fig. 3. It should be noted that the colour response

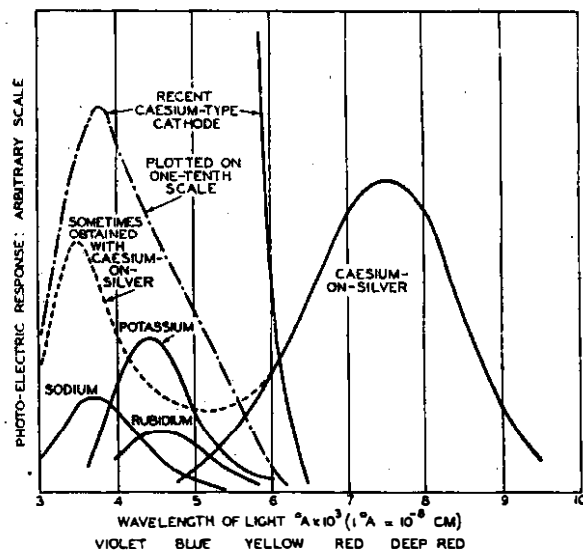

FIG. 3.—COLOUR CHARACTERISTICS OF VARIOUS CATHODES.

of "caesium" cathodes is very dependent on the material on which the caesium is deposited and on the method of manufacture.

These curves show that, apart from a recently developed caesium-on-antimony cathode, not yet generally available in this country, the caesium-on-silver cathode is the most sensitive for all ordinary work; its strong maximum in the deep red is ideal for use with incandescent lamps, while the good general sensitivity renders it somewhat better than other cathodes for use with daylight.

Frequency Response to Interrupted Light.

Vacuum and secondary-emission cells respond satisfactorily to the variations in light interrupted at frequencies up to about 1 Mc/s, above which the inter-electrode capacitance limits the load impedance which can be used. In a gas-filled cell, however, the comparatively slowly-moving ions require a time of the order of 10^{-5} sec. to reach the electrodes. For this reason the response to frequencies higher than about 5,000 c/s is progressively reduced. In cells using the high gas-pressures which are necessary to obtain high gas-magnification, this effect occurs most strongly.

Life.

The life of a well-made and properly-used vacuum cell is indefinitely long. Barring mechanical damage, failure can be due only to changes in the properties of the cathode, possibly through the chemical action of impurities, either originally present in the cathode or slowly evolved from the glass envelope. The cathode of a gas-filled cell is liable to the above troubles, and is also subject to the normal bombarding action of the gas molecules; even so, cells generally have lives of many years.

USES AND CIRCUITS

The circuits in which emission-type cells are used may be classified as D.C. (using galvanometers, etc.) or A.C. (using valve amplifiers). The source of intermittent light responsible for generating A.C. may be, for example, the light transmitted through sound-film or the scanning beam used in television. Intermittent sources also include beams of light otherwise steady but interrupted at regular intervals by a shutter, and the light from flashing lamps (e.g., gas-discharge lamps operating on A.C.).

D.C. Methods.

The D.C. output of a cell may be measured by a sensitive high-resistance galvanometer. A protective resistance (of say $\frac{1}{2}$ megohm) should be connected in series with the cell to guard against accidental heavy currents which might damage not only the galvanometer but also the cell.

For precision work vacuum cells are preferable, since their sensitivity is less dependent on the applied potential. For great sensitivity to weak illumination the galvanometer may be substituted by an electrometer.² A convenient circuit is shown, in principle, in Fig. 4; it can be adapted to form a null method. In this circuit the electrometer measures the rate of charging of a condenser. Even greater sensitivity has been obtained by using a Geiger-Muller counter³

(a triggering device responding to single electrons), with which currents of the order of 2×10^{-20} A—i.e., 0.1 electrons per second—have been detected.

These methods are essentially quantitative. They are used for lamp photometry, and for the measurement of intensity of weak sources such as stars; they are also used for the measurement of the optical transmission and reflection of various materials, for colour matching (using colour filters), and so on.

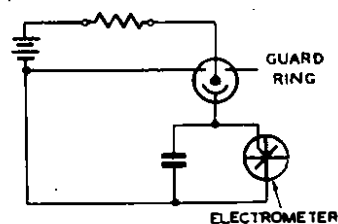

FIG. 4.—CELL USED UNDER D.C. CONDITIONS.

A.C. Methods.

The small currents available from a cell, although unsuitable for the direct operation of mechanical devices, may be made to operate relays, etc., by means of valve amplifiers or gas-filled relays. The cell may be used with a load whose value is limited only by the characteristics of the following valve; 2 megohms may be permissible, and if so a response of the order of 1 volt for 0.01 lumen is obtainable.

Fig. 5 shows alternative circuits for connecting a cell to a valve or gas-filled relay. When an interrupted source is used as suggested above it is often useful to tune the amplifier to the frequency of interruption.

These methods are useful for alarm systems and for mechanical counting devices. With suitable pre-

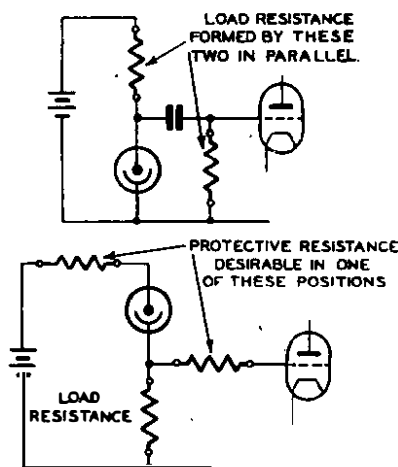

FIG. 5.—CELL USED UNDER A.C. CONDITIONS.

cautions in the matter of amplifier stability they can also be used quantitatively for purposes such as those listed in the section on D.C. methods.

Reproduction of Sound-Film.—For sound reproduction from film a gas-filled caesium cell is normally used, as it has high sensitivity without requiring abnormally high voltages and it has sufficient frequency range. With the usual type of exciter lamp (an over-run lamp of up to 75 W) and optical system, the output from the cell is of the order of 10 mV in 500,000 Ω . The circuits of Fig. 5 are used.

Generation of Television Signals.—The high frequencies required for modern television (up to about 5 Mc/s) prohibits the use of gas-filled cells. The difficulty of working over this wide frequency-band without introducing excessive noise in the early stages of the amplifier led to the use of secondary-

² e.g., Rayleigh, *Proc. Roy. Soc.*, A 124, p. 395 (1929).

³ Locher, *Phys. Rev.*, 42, p. 525 (1932).

emission cells. These, however, are now largely superseded by the "Iconoscope," a device which introduces a new principle—that of storage of the signal, with electrical scanning of a large number of elements of the cathode area. By accumulating the signal over a much greater time than is available in the usual mechanical scanning process, reasonable sensitivity is achieved with a vacuum-type cell.

Notes on Intensity of Sources.

In calculations of the response to be expected from a photo-electric cell, it should be remembered that only a small part of the light emitted by a lamp can be collected by any practicable lens system; for example, a conventional condenser lens rarely collects more than one-sixteenth of the light from a lamp. A deep parabolic reflector can collect nearly half the light; but such reflectors are rare. Of the 4π lumens emitted per candle-power, therefore, less than 1 is likely to be useful in an optical system.

COMMERCIAL USE OF PHOTO-ELECTRIC CELLS

It will be seen that photo-electric cells are as easy to use as thermionic valves, both for laboratory measurements and in engineering apparatus. The cells are robust and have excellent stability and life. It might also appear that the cells could be manufactured as easily and cheaply as lamps or valves, but for several reasons this is not so. The demand for photo-electric cells has hitherto been small, and is likely to remain so, if only because of the long life. Also there are manufacturing difficulties. Great care must be taken at all stages in the handling of the cathode, caesium being a substance particularly sensitive to contamination and to thermal effects;

further, the impossibility of using a "getter" to remove unwanted gases entails unusually thorough pumping. Up to the present, commercial production has scarcely left the laboratory stage, and the fundamental physics of the cathode surfaces used is not well understood.

The colour-response of the more sensitive types is so very different from that of the eye that correcting filters must be employed if cells are used for colour matching (as required in the dyeing industry), and for lamp photometry; these filters reduce the sensitivity so much as to restrict the use of photo-electric methods.

Emission-type cells cannot be used in photographic exposure meters or in foot-candle meters because, again, the colour response is wrong; also, the polarising battery and sensitive galvanometer are inconvenient. The inability of these cells to operate mechanical devices without auxiliary apparatus limits their industrial use—e.g., in counting devices.

Possible future developments include the use of emission-type cells for the conversion of an infra-red to a visible image; the development of cathodes having a colour-response similar to that of the eye, and therefore suitable for use in colour-matching without loss of sensitivity; and greater total sensitivity—the theoretical limit has not yet been approached.

Future Post Office uses may include the wider adoption of "speaking" devices such as the Speaking Clock and the Delay Announcer; and there have been references in recent patents to the use of photo-electric cells to detect lamp signals given in automatic telephone switching. Considerable use in the handling and sorting of postal packets is technically possible.

Air Raid Damage to Post Office Telecommunications

E. C. BAKER

Part IV.—Damage to Overhead Plant

U.D.C. £23.45:621315.1

Overhead plant has not suffered damage from air raids to the same extent as internal equipment and underground cables, but the author gives examples of such damage as has been incurred due to enemy action.

Damage to Overhead Plant.

AFTER recording some of the damage done to telephone exchange buildings and underground plant it is to risk an anti-climax to review air raid damage to overhead plant. Such damage has been very small compared, for instance, with that caused by the freak storm at the end of January, 1940. That storm was, from its effect on overhead plant, the worst ever experienced in the South of England. After weeks of bitterly cold weather there was a continuous fall of fine rain which froze on coming to rest, and within two days the exceptional ice loading on the open wires had wrought great havoc. The continuing bad weather, and the isolated areas in which much of the damage occurred, hampered restoration work. All the air raids together have caused damage nowhere near the extent of this, nor in such isolated areas or in

such quantities at a time as to embarrass seriously the external staff.

The earliest damage by enemy airplane reported was on February 3rd, 1940, when a Heinkel bomber was shot down two miles to the west of Whitby. This was the first of enemy planes to be brought down in this country during the present war. As it crashed the raider carried away five spans of a line of eight telephone wires—the damage was repaired the same day.

The next instance of damage by enemy aircraft attracted a certain amount of attention when just after eleven o'clock on the night of April 30th a Heinkel 111, engaged on mine laying, crashed at Clacton-on-Sea and its cargo blew up. To the two night operators on duty at the manual exchange it seemed from the lamps that lit that almost every subscriber had, on hearing the explosion, gone

straight to his 'phone. Some lamps on the switch-board were glowing because subscribers' instruments had been blown off tables or desks by the explosion. Several members of the public called up to ask the exchange staff questions. A number of London reporters put through trunk calls with requests to the supervisor to be connected to a subscriber near the accident: requests that were quite properly refused. Within a few minutes of the explosion two members of the staff off duty arrived to assist in handling the rush of traffic.

There was blast damage within a 350 yards radius of the exploded mines, but of the 108 subscribers in this area only 22 circuits were faulty of which 12 were led from one distribution pole. The remaining faults were simple—wires twisting or breaking in a single span to cause short-circuits. It was recorded that apparatus was recovered on twelve exchange lines—with half of these the apparatus was badly damaged and the owners of the other houses decided to leave: All of which, while it caused some excitement at the time, is very insignificant in the light of subsequent events.

Balloon Barrage Damage.

Overhead plant proved vulnerable to another form of damage which in a negative sense was a result of air raids. This made its effect first felt the day before the war started, when a barrage balloon fouled the grid electric supply system near a north-east town and thus interrupted the power supply to teleprinters for two hours. Escaping barrage balloons have brought down a number of overhead lines with their trailing cables and on a few occasions their exact path across country to the sea could be determined from the spans of wire that they brought down *en route*. This sort of damage can usually be handled expeditiously. Nor are there likely to be any hard feelings on the part of the external staff called upon to do the work especially when, as was once reported from South Wales, the balloon had brought down an enemy plane before breaking away. Sometimes a stray balloon would damage poles as when, in a gale on the South Coast, one got out of control and its cable twisted around a 45 ft. medium pole pulling it right out of the ground to leave a clean circular hole! The balloon then carried the pole into an adjoining street where the cable snapped to deposit the pole into the forecourts of some private houses. Such extractions were not always so clean: we learn of a balloon-hawser wrapping itself around a 36 ft. light pole, carrying 16 wires, wrenching it out of the ground and carrying it some 500 yards when the pole snapped in two and the lower portion dropped into a playing field, the upper portion being carried a further 400 yards before coming to rest in the garden of a house. On another occasion a balloon being prepared for ascent became entangled with a light pole because of the gusty weather. The R.A.F. team in charge of the balloon decided that the only way to free it was to saw off the pole, four feet from the butt. The balloon then rose suddenly to carry the 18 ft. top of the pole a thousand feet high in the air, whereupon it worked free and plunged to earth striking the ground

near the motor winch; fortunately this incident caused no damage other than to the pole itself and the wires it was carrying.

Damage to Poles.

A number of poles have been burnt by incendiary bombs, or by fires started by incendiary bombs. Others have been broken or deflected, but it is true that poles near bomb explosions often escaped displacement or damage. In one southern town a distribution pole, which had stood for 31 years, was but a few feet from an exploding bomb that made a large crater in the road. The condition of nearby houses showed that the pole was in the direction of the blast, but there was no sign of injury to it although the wires radiating from it were blown down.

After a heavy raid on one town the survey party reported that a 55 ft. distribution pole had vanished. This was sufficiently unusual for an investigation to seem worth while: When a large quantity of debris had been removed from the site the stump of the pole was discovered, but of the remaining 50 ft. there was no trace. The officer in charge was unable to think of an explanation for the disappearance of such a large quantity of timber and so had to content himself with a request to the foreman of the survey party to keep his "eye open"! A few days later the foreman phoned him to give the information. It appeared that the force of a bomb explosion had pitched the pole over a 30 ft. building into the next street where it crashed through the roof of a public house, coming to rest on what our informant describes as "the right—or service—side of the counter." He adds, darkly, that "it was an ex-National Telephone Company's pole."

Damage to Aerial Cables.

There have been a number of instances of damage to aerial cables by anti-aircraft shell splinters. On one occasion a machine-gun bullet was found embedded in an aerial cable—where it had put all the circuits out of action. An unusual fault which proved difficult to locate was a transient intermittent fault eventually found to be in a 15-pair aerial cable out in a remote rural district. This cable was carefully examined throughout its length and in three or four places it was found that its lead sheath bore fairly deep serrations—clearly caused by the cable rings. There was no acute angle or constructional defect, which might have been a contributory factor to this malformation. The lead sheath though crimped and slightly elongated at the point of suspension was not cracked or perforated. The discovery was made after a most detailed examination that, although to visual inspection the copper conductors appeared undamaged, the paper insulation on several of these conductor wires was clearly broken, thus leaving the wires bare. This was the actual cause of the intermittent faults, but there is little doubt that the primary cause of the trouble was blast from a bomb. A bomb had exploded in the ground nearby about eight months before. Although the lead sheath would give under the sudden strain imposed by the explosion the paper insulation, having negligible elasticity, would be broken.

The London Telecommunications Region Power Section Workshops

C. A. R. PEARCE,
M.Sc., A.M.I.E.E.

U.D.C. 621.9

New workshops are described which are equipped to undertake miscellaneous ironwork in the London Telecommunications Region. Examples of work executed in these workshops are given.

Introduction

MOST Regions are provided with workshops for constructing exchange ironwork and undertaking small repair jobs, etc., but the

necessary, although emergency repairs were carried out and provided a temporary relief. The opportunity was taken to build shops more suited to their intended purpose than the buildings they replaced, thus affording the increased accommodation necessary to deal with the greater volume of work.

The new shops are now complete, and have been equipped and occupied, and the time seems opportune to describe this feature of the work of the London Telecommunications Region which is unlikely to be met elsewhere. Adjacent workshops house staffs of carpenters, painters, etc., but in this article only the work of the engineering fitters is dealt with.

The New Shops.

The new buildings consist of twin bays of standard wartime factory buildings, which afford a floor area of 69 ft. × 89 ft., and constitute the main workshops, together with a smaller building and which is used as a smithy. (Fig. 1.)

The main framework of the new workshops consists of reinforced concrete sections bolted together. The roof is of asbestos sheets and the walls of 4½ in. brick, on 9 in. brick foundations with a 6 in. concrete floor. The whole design of this type of building centres on the need for speedy erection, and the buildings are not

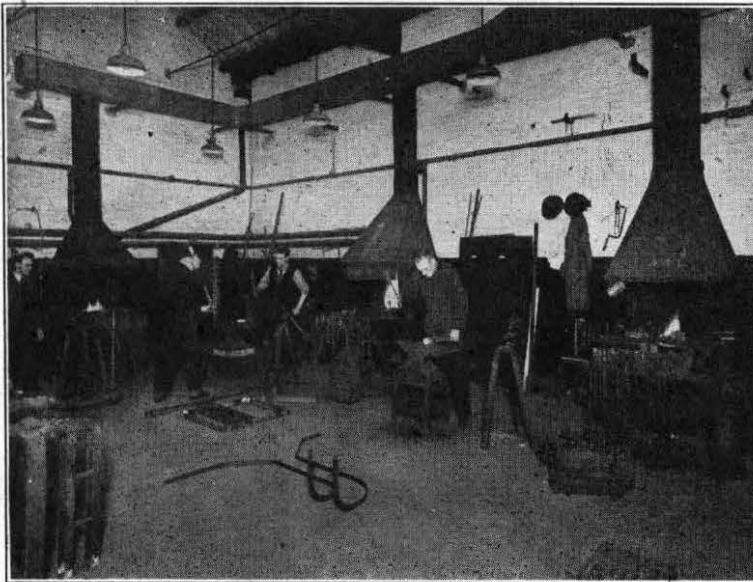

FIG. 1.—BLACKSMITH'S SHOP.

greater concentration of the London Region has permitted this feature to be developed to a degree not profitable elsewhere. For many years a staff of tradesmen fitters formed part of the C.T.O. Section of the London Engineering District. They were housed in premises originally provided for a very different purpose, and carried on their work under some difficulty because of this. The great increase in the amount of internal construction work carried out by the Post Office by direct labour, brought about by the war and the events leading up to it, had its repercussions on the Regional workshops. By the beginning of the war, the number of staff employed in the fitters' shops had increased to such an extent as to make the accommodation uncomfortably crowded, and plans for rebuilding were well under way when the outbreak of hostilities caused them to be shelved.

In September, 1940, however, the blast from a land mine which fell on a nearby building so damaged the shops as to make complete rebuilding

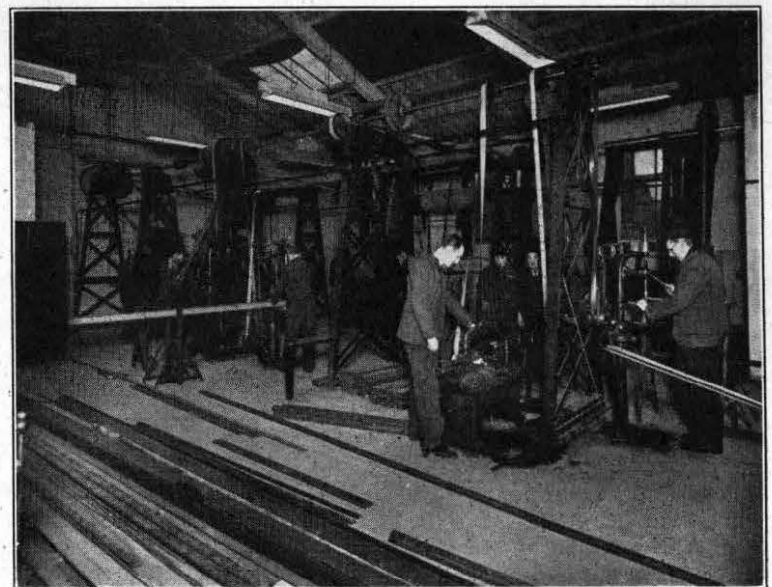

FIG. 2.—PART OF MAIN WORKSHOP.

expected to last for any considerable time after the war. An important feature of the design from the point of view of the occupier is the flimsy nature of the walls which cannot be used for carrying loads. All loads must, therefore, be carried by the floor, and braced frameworks are used to support the line shafting driving the machine tools. These lattice frameworks, which were designed in the Power Section Drawing Office, are part riveted and part welded, and were constructed and erected by the workshop staff. Fig. 2 shows the section of the shops given over to machines. These are of the usual types necessary for straightforward fitting work, i.e., lathes, drilling machines, machine hacksaws, etc.

A feature of the machine tool equipment is the relatively large proportion of machine hacksaws used. In making up cable racking, bearers, apparatus frames, etc., many of the parts are simply cut from the straight, but are of too heavy section to be dealt with by manually operated shears, and the high first cost of power driven shears cannot be justified. Hence the machine hacksaw plays an important part in turning out the work at minimum cost.

The general lighting of the shops is by fluorescent type 80 watt fittings. This follows the present general trend in industrial lighting practice. The cost of a lighting installation employing fluorescent fittings is higher than an equivalent layout employing incandescent lamps, but the saving in current resulting from the higher efficiency of the former, offsets this higher first cost to an extent which depends on the period for which the artificial lighting must be employed and the cost of energy on the site. In these workshops not only is current expensive but artificial lighting is required for a high proportion of working hours. In addition a high standard of lighting is now recognised as essential in workshops, not only because of its effect on health and efficiency, but because it mitigates against accidents. This factor also operates in favour of the use of fluorescent lighting, because its colour correction and the large area forming the source of light, permit of the use of high illumination intensities without giving rise to discomfort from "glare." Heating is by a hot water system. Both the lighting and heating installation work was carried out by the staff of the Section.

Nature of Work Undertaken.

The workshops form part of the London Telecommunications Region's Power Section, and undertake a wide variety of engineering fitting work. The officer in charge on the site is a Chief Inspector, and the workman staff consists of some seventy engineering fitters, most of whom are tradesmen. They include blacksmiths, welders, turners and millwrights.

In planning a new exchange to be housed in an empty and modern building, the designer can generally avoid any considerable number of bends and sets in the cable racking, but when Post Office staff are installing P.B.X.s in old and

already congested buildings, or are adding equipment to exchanges not initially designed to contain it, there is not the same freedom of design, and a much larger proportion of the racking consists of awkward bends and sets, necessitating work by blacksmiths, and an important part of the work falls to these men. Some of it calls for very skilled smithing.

The standard method of construction employed in the past, and still largely the vogue, was riveting, but in telephone engineering, as elsewhere, the welder is tending to displace the riveter and blacksmith, and an important and growing proportion of the work of the shops is carried out by welders.

At present the only welding process employed is oxy-acetylene, and this, to some extent, limits the sphere of application. Owing to the intense local heating inherent in this process, and the consequent warping it produces, it is in general unsuited to the fabrication of the larger types of framework. The electric welding process largely obviates this warping, but, on the other hand, the plant required involves a high first cost which so far has not been found to be justified. The distortion of a large framework due to oxy-acetylene welding can sometimes be removed by straightening the members after the welding is completed, but this again is relatively costly, and usually a better course with large or complex frameworks is a compromise involving part fabrication by welding and then assembly into the final complete framework by riveting after a preliminary "straightening-up."

Fig. 3 shows some of the welders at work. One of the men can be seen working on a large circular tacking bar intended to carry cables up a vertical circular shaft 12 ft. diameter.

Although the workshops do not normally carry out work of a repetitive nature there are occasions when, because of special considerations work is undertaken in a sufficient quantity to make it worth while to build jigs, and at times even to purchase special

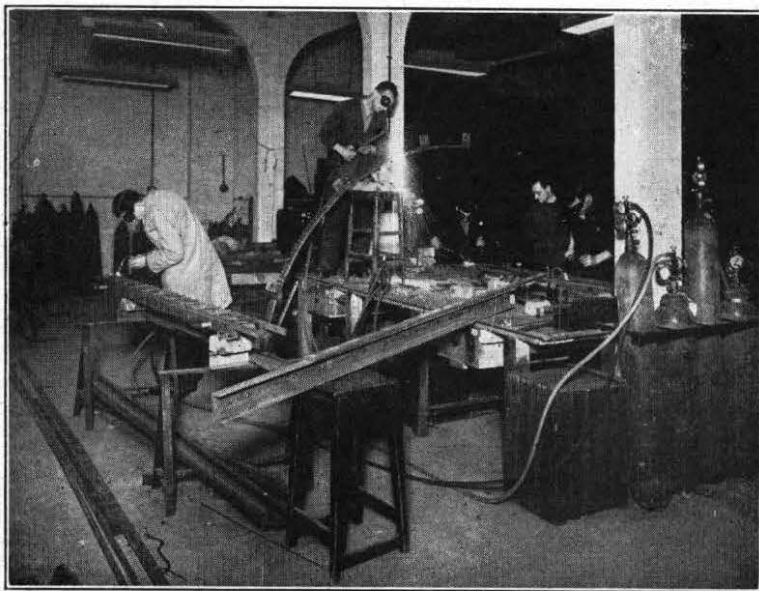

FIG. 3.—WELDER'S BENCH.

tools to ensure that a minimum of labour is expended. One such job was the manufacture of several hundreds of the cable bearer illustrated in Fig. 4. These bearers were required quickly, and each of them had to be fitted initially with three of the eight cantilever brackets which they will ultimately carry. The main channels were delivered cut to length at small extra cost, and a jig was designed to facilitate the rapid drilling of the holes of which each channel requires sixteen. Using a jig and a high speed drill with power

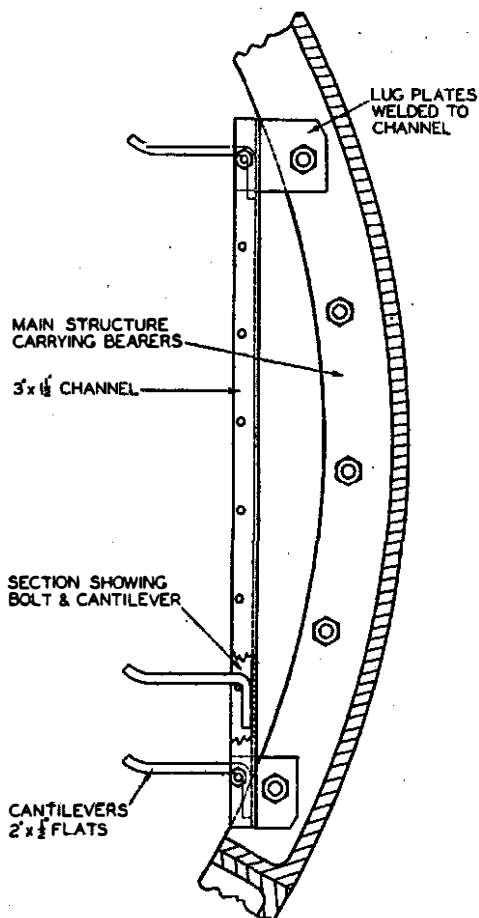

FIG. 4.—CABLE BEARER.

feed, one man was able to drill each channel, which is $\frac{1}{4}$ in. thick, with sixteen $\frac{1}{8}$ in. holes at the rate of 70 or more channels per $8\frac{1}{2}$ hour day, which is an average rate of about two holes a minute. An ordinary carbon steel drill working under these conditions was found to require regrinding about once every half an hour, but with the high speed tungsten steel drill referred to, it was not necessary to "touch-up" the tool even as much as once a day. The lug plates were secured to the channels by welds along two of their edges instead of the usual four, and this was tested and proved to be easily able to carry the full cable load on the bearers. The cantilevers were bent up cold, the lips being set in a hydraulic bending machine, and the angles on an ordinary lever type hand bender. This job is typical of the class of work carried out by the shops, except as regards the quantity.

The workshops also carry out repairs to emergency charging plant for the whole of the London Telecommunications Region, and Fig. 5 shows an interesting example of this type of job. A petrol engine was recently fitted in one of the 67 kilowatt standby

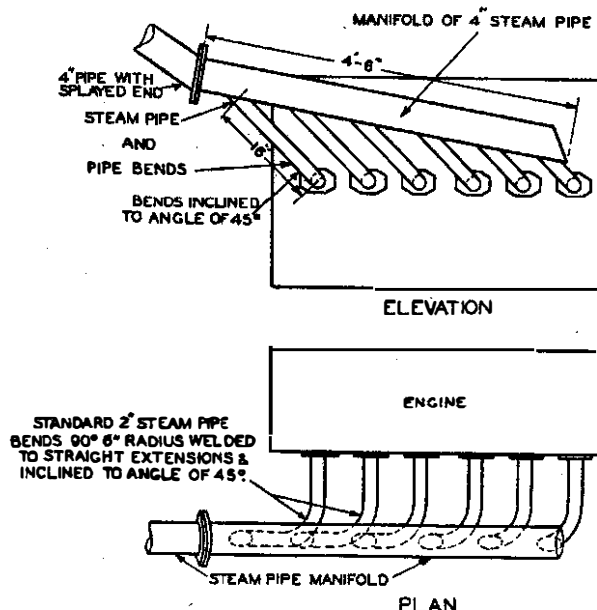

FIG. 5.—FABRICATED EXHAUST-MANIFOLD FOR 67 kW PETROL ELECTRIC SET.

sets in place of the original Diesel engine. When the set was delivered by the contractors, the engine not only failed to develop its rated power, but the exhaust system quickly reached a bright red heat, which, apart from other undesirable effects, infringed the black-out regulations at night. The trouble was traced by the fitters to the turbulence set up in the exhaust system by the large number of bends which it incorporated. The exhaust system was redesigned and among other things a new manifold was constructed. This is shown in Fig. 5. It was constructed from ordinary quarter pipe bends by the welders. This, again, is a job calling for a fairly high degree of skill from the workmen. With the redesigned and rebuilt exhaust system, the engine was found to give its full output and the temperature of the exhaust box, etc., was reduced to a dull purple.

Another job of this kind was to mount one of the six kilowatt emergency charging sets on pneumatic tyres and a sprung chassis, suitable for towing behind a lorry. When the original sets of this type were delivered they were mounted on small diameter block type cast iron wheels without tyres, and could only be moved any distance by road by first loading them on to a low loading freighter. Unless overhead lifting tackle was available, this preliminary operation was in itself an awkward process, and liable to involve some delay in getting the set to its working site. Recently the modification of these sets to render them suitable for towing on the road has been going on throughout the country. The prototype of the new chassis was designed and constructed by the staff of the Power Section workshops. The modified sets

have been safely towed at 35 m.p.h. The modifications were made without dismantling the set, the main channels at the base being used to attach angles carrying the springs. Both hand-operated and automatic braking from the tow bar is provided.

The last example of the work of these shops is the cable bridge shown in Fig. 6. During the "blitz" on London, it was decided that transportable cable bridges should be constructed, so as to be available for carrying heavy cable routes over large bomb craters which might occupy the whole available width of a road, and a lattice type sectional bridge was designed in the Chief Regional Engineer's office, and constructed in the workshops. The bridge can be erected from either three or five sections; the three section bridge gives a length of 36 ft. and is capable of carrying almost any likely load across a clear span of 33 ft. With five sections added together, a clear span of 56 ft. is available to carry a distributed load of some eight tons. If a central support can be arranged for the longer bridge, then again almost any number of cables which can be placed on the bridge can be safely carried by it. The bridges are of riveted construction except in one case in which welding was tried to see what advantages it offered, but in this instance it was found that there was nothing to be gained by its use, owing to the warping which was brought about by the local heating of the section members, and the resultant difficulty of straightening up afterwards.

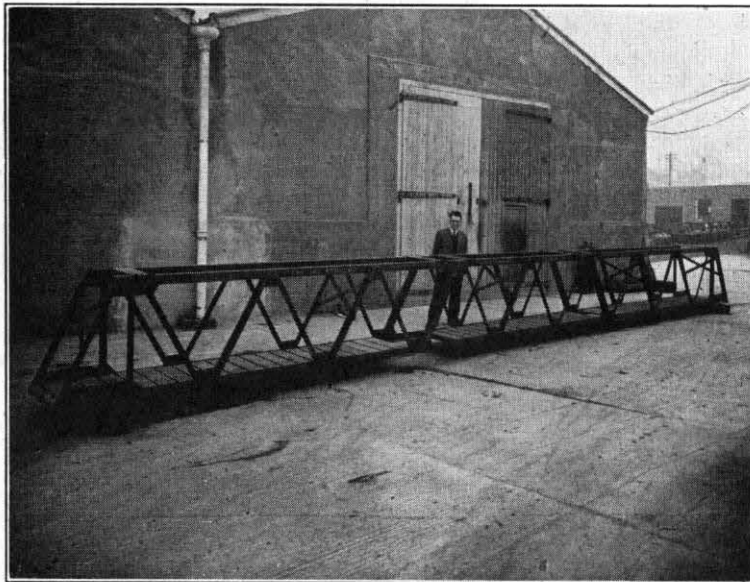

FIG. 6.—3-SECTION EMERGENCY CABLE BRIDGE.

The examples of work carried out by the L.T.R. fitters are not exhaustive, but they serve to illustrate the variety of work undertaken by the shops. A great deal of the day-to-day work consists of making and erecting cable racking, main frames, special apparatus racks, etc.

It is hoped that this short article will have served to convey some idea of a phase of Post Office work which has received very little publicity, but which nevertheless takes a share in many of the major works undertaken by the L.T.R.

Cable Test—London

A. E. MERCER.

U.D.C. 621.315.68:621.317.33

This article describes the functions and method of working of a group known as "Cable Test—London," which was set up in 1941 to deal with breakdowns of trunk and junction cables, particularly those due to air-raid damage.

Introduction.

PRIOR to 1941 all trunk and junction cable breakdown repairs in the London Region were controlled by the Toll A test room staff. This method of working was satisfactory in normal times, but under blitz conditions it was considered that added efficiency would be obtained by forming a separate group to deal with these breakdowns. Such a group, known as Cable Test, London, was established in January, 1941, and is staffed on a 24-hour basis.

The function of the group is to locate breakdowns on all trunk and junction cables controlled by London Trunk Exchange, to advise the Area concerned of the location of the fault and to keep the controlling groups in the Regional Engineer's and Long Distance Area Engineer's offices informed of the nature and extent of the breakdown, progress of repairs, etc.

A slip number is obtained as a reference and check from each group so advised.

System adopted for Fault Location and Clearance.

When a breakdown occurs the fault is localised in conjunction with an external gang in the normal manner. Usually the cable has to be opened, and for most faults it is advantageous to establish a speaker circuit between Cable Test and the jointer as early as possible.

If the breakdown necessitates running lengths of new or interruption cable the method of jointing to be adopted has to be decided. This depends partly on whether intermediate joints are involved. In general, one of three methods is adopted:—

- (a) to copy the existing joint;
- (b) to connect straight through at one joint and number out at the other;

(c) to prepare and work to a jointing schedule.

Co-operation with the jointer in this matter is an important factor in the speedy restoration of cables.

As the jointing proceeds the jointer advises Cable Test that certain pairs are ready for testing. Depending on the method of jointing adopted these pairs may or may not be in correct numerical sequence. If the pairs are connected through in the same order as before the breakdown the testing is carried out by a frame-to-frame test, but if the order is changed the testing is undertaken at the Test Desk. Tests are made to ensure continuity, satisfactory insulation, and freedom from A and B reversals, contacts and split pairs. On completion of the work the Chief Regional Engineer's Group, the Long Distance Area Group and the Long Distance Traffic Division Control are advised by telephone that the cable is restored to normal working, reference numbers being obtained from each. Similar procedure is followed for both temporary and permanent repairs.

It is essential that the Long Distance Traffic Division Control be advised early of the restoration of a cable, since they adjust the location and distribution of the operating staff accordingly. At times a cable breakdown may necessitate the opening of "interception" exchanges, and it is obviously important that the staff at these exchanges should return to their parent exchanges as soon as the breakdown has been rectified.

Localisation of faults on individual wires or pairs is also carried out from Cable Test, the results being given to the Area concerned. Faults of an incipient nature, split quads, etc., are passed to the Precision Testing Officer to deal with.

Work under "Blitz" Conditions.

The load carried by Cable Test during the period of heavy bombing raids on London in 1940-41 was considerable. The nature of this load was naturally

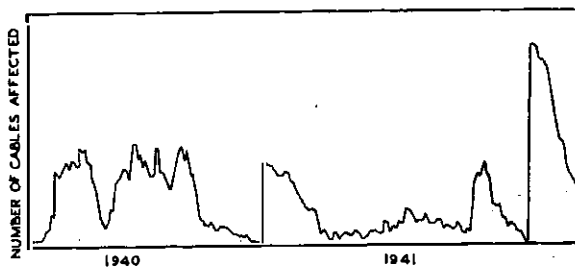

FIG. 1.—GRAPH ILLUSTRATING INCIDENCE OF CABLE FAULTS.

very peaky, as shown by Fig. 1, which also illustrates the rapid manner in which cables were restored to service, although for security reasons no value can be given to the co-ordinates.

An added difficulty in the location of faults was that, on occasion, more than one breakdown existed on the same route. To assist in the rapid location of faults under these conditions normal testing methods were supplemented by visual examinations of sections of the route, and an inspection of bomb craters. At times this work was somewhat hazardous due to fires and the danger of buildings collapsing.

A typical repair was one carried out in the spring of 1941 close to the Cable Test headquarters. A collapsing building within four yards of the work added to the difficulties of repair, and eventually necessitated a certain amount of demolition. This breakdown was of particular interest in that it involved a co-axial cable, a considerable length of which had disappeared. Twin I.R.V. cable was used as a temporary replacement, the method of jointing the I.R.V. to the co-axial cable being shown in Fig. 2. The temporary repair was successful and remained in service until the winter of that year.

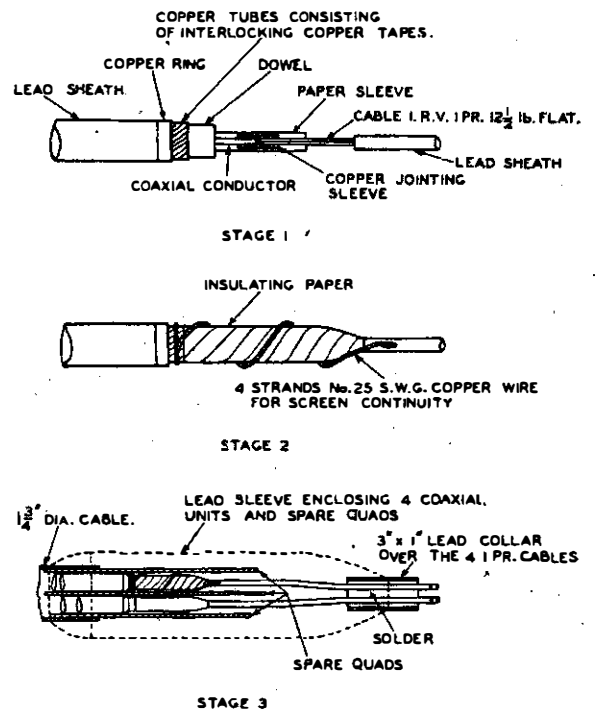

FIG. 2.—TEMPORARY REPAIR TO COAXIAL CABLE.

Permanent Repairs.

After mid-summer of 1941 damage due to air-raids fortunately subsided and enabled Cable Test, in conjunction with the Precision Testing Officer, to concentrate on the restoration of the trunk and junction cable network to its normal standard, and to give attention to faults on individual circuits.

Some American Army Line Construction Tools

U.D.C. 621.315.17 621.315.29

Lt. F. DANIELS* and
E. J. V. TURNER

This article describes some of the tools and mechanical aids with which the American Army Signal Corps is equipped. These include an earth auger and a winch driven from the engine of the vehicles concerned.

Introduction

A SIGNALS unit of the U.S. Army stationed in the Home Counties Region extended an offer of help to the Post Office Engineering Department's staff after an air raid. This offer was gladly accepted by the Post Office, and it was thus possible to see the American tools and mechanised aids in use, and to learn their value by practical experience. Some of these tools are described in this article.

UTILITY VEHICLES

Mobile Earth Boring Machine

On level ground the earth boring machine incorporated in this vehicle (Fig. 1) will bore holes up

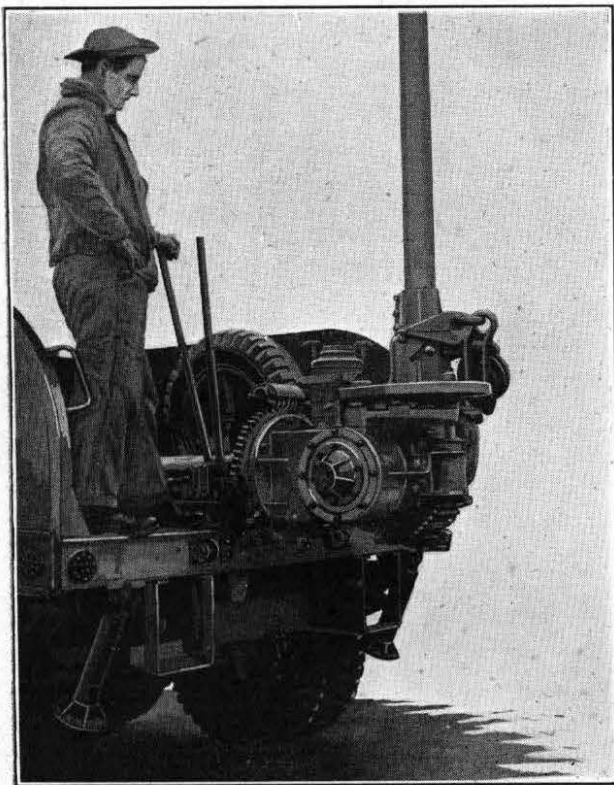

FIG. 1.—EARTH BORING MACHINE

to 30 in. diameter and 8 ft. 4 in. deep. A 2½-in. rock drill, 6, 9, 12, 26, 20, 24 and 30-in. augers and an auger extension are used with this machine. Double-bladed augers with gates to trap the dirt are best adapted for digging in sand or gravel;

* American Army Signals Cons. AVN.

whereas the single-bladed augers (Fig. 2) are better for loam, clay and particularly where rocks are involved. Rocks up to 10 or 12 ins. in diameter may be raised without damage to the machine or undue difficulty.



FIG. 2.—SINGLE-BLADED EARTH AUGUR.

For travelling, the boom containing the rack shaft is lowered forward until its upper extremity rests upon the truck cab. To operate the borer, the boom is first raised to the working position and the truck manoeuvred on to the desired spot. The raising of the boom is accomplished by power from the engine of the vehicle, and the boom is adjusted to a vertical position or to such an angle as may be required by two levelling gears operated by hand-cranks. Once the boom is in position all the boring operations are controlled by movement of the two levers, which can be seen in Fig. 1.

While boring is in progress one man operates the levers attached to the boring machine and another sits in the driver's cab and controls the engine throttle and manipulates the gears to provide slow or fast boring speeds to suit the various types of soil.

Suitable levers in the cab transfer the power from the engine shaft to the road wheels, earth borer or winch as required.

The instructions to bore are as follows :—

Signal for boring speed which ordinarily is high speed of the transmission or one speed lower. Pull hard on left-hand lever, which controls the vertical motion of the borer, and push easy on right hand, which controls the rotary motion. When the auger is near the ground, push hard on both levers and bore until the auger is buried to a depth of 18 ins. To raise auger pull hard on right-hand control lever, push easy on left-hand control lever until auger rises 18 ins. above the ground, then push on both levers to throw off drillings. This is accomplished by centrifugal force. Repeat these operations until the hole is bored to the required depth.

When the hole has been bored the pole may be erected by moving the truck about 2 ft. forward and giving the boom a slight rake aft. The steel wire from the winch drum situated behind the driver's cab is then passed over the sheave in the top of the boom, and by an S-hook in the eye splice the wire is secured around the pole. Then by applying power to the winch the pole may be first pulled to position from anywhere within reach of the winch rope, then raised and lowered into the hole prepared for it.

Thus the hole is bored, the pole brought, raised and set in position without any manual effort at all, the only handling necessary being the guiding of the butt into position.

The four-wheel drive of the truck on which the auger is mounted is invaluable for backing into and emerging from ditches, etc., bordering roadside verges and hedge-banks in which poles have to be erected.

The Line Construction Truck (Fig. 3)

This also is a triumph of co-operation between



FIG. 3.—LINE CONSTRUCTION TRUCK.

the U.S. telephone engineers and the truck designers and manufacturers. Its main features are :—

- (i) Power-operated winch driven off the engine shaft through variable gears ahead and reverse.

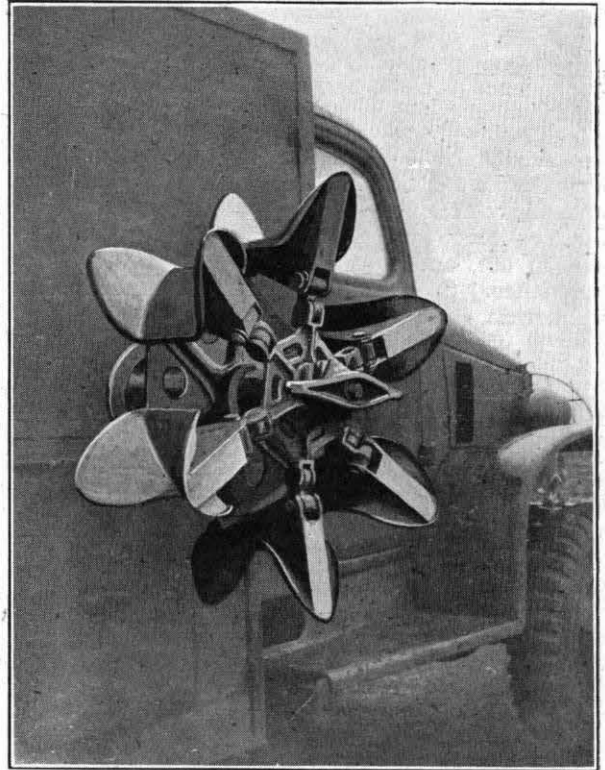

FIG. 4.—DETACHABLE CABLE DRUM.

- (ii) Specially designed detachable drum with collapsible outer flange (Fig. 4) for attachment to an extension of the winch spindle outside the truck, and for use in paying in and paying out wire or aerial or underground cable. The variable speed gears of the winch make this a very useful addition, and the collapsible outer flange of the drum allows coils of wire to be taken off after winding in or out.
- (iii) Derrick and adjustable prop (Fig. 5) which, together with the winch and steel rope, enable pole lifting, erection and recovery, to be performed without manual labour.
- (iv) Sliding roof which allows the erection of the derrick and rope, yet provides suitable covering when the former are struck and stowed in the locker alongside the truck.

- (v) Well-designed lockers for all tools and stores with diagram fixed to locker door to indicate the correct position for every tool and fitting carried on the truck.

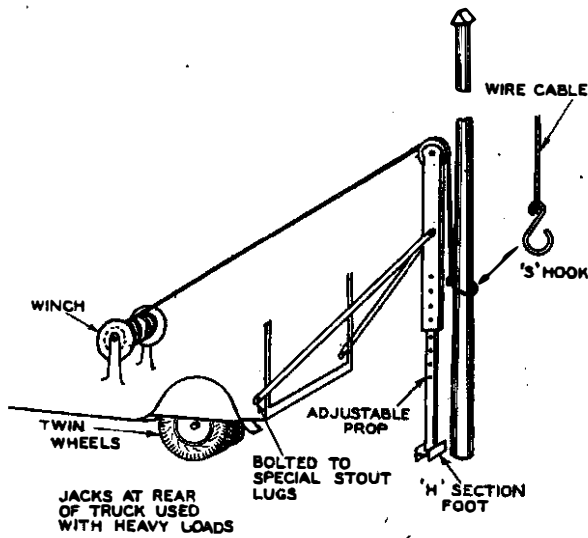

FIG. 5.—RECOVERING POLE WITH DERRICK AND WINCH.

- (vi) An insulated tank which holds 2-3 gallons of drink for the crew and maintains the liquid temperature either hot or cold for several hours.

The truck is of the four-wheel drive type with double rear wheels and can negotiate fairly soft land without getting stuck.

In addition to the uses outlined above, the derrick may be used for such other purposes as:—

- (a) Unloading poles from rail trucks.
- (b) Loading poles into lorries.
- (c) Erecting or recovering loading pots on aerial lines.
- (d) Erecting or recovering loading pots from underground manholes, etc.

HAND TOOLS

A number of small items and hand tools appear worthy of special note, in particular the following:—

Lag Wrench (Fig. 6)

This tool fits all the nuts on a P.O. pole, and being 18 ins. overall, gives extra leverage; at the same time

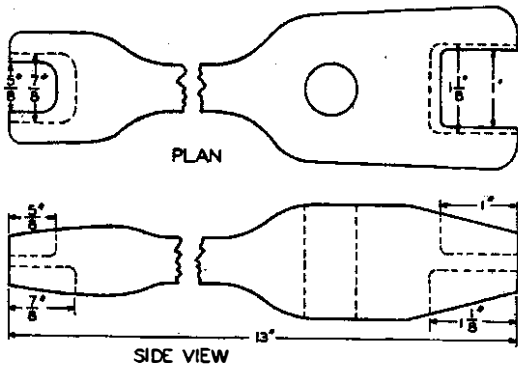

FIG. 6.—LAG WRENCH.

its tapered jaw enables it to be used at such an angle as to clear other adjacent fittings.

Eccentric Point Type Connecting Pin (Fig. 7)

This pin is locked in place when the point is turned through 180° from the position in which it is inserted in the hole. When used as a pivot pin the head of the pin is flattened so that it will rest against a stop on the member or mounting bracket to prevent turning, since turning might unlock the point. The pins are short enough so that the point cannot be turned unless the flat section of the head is against the stop. The point of the pin has a hole drilled in it for the insertion of a nail to assist in turning the

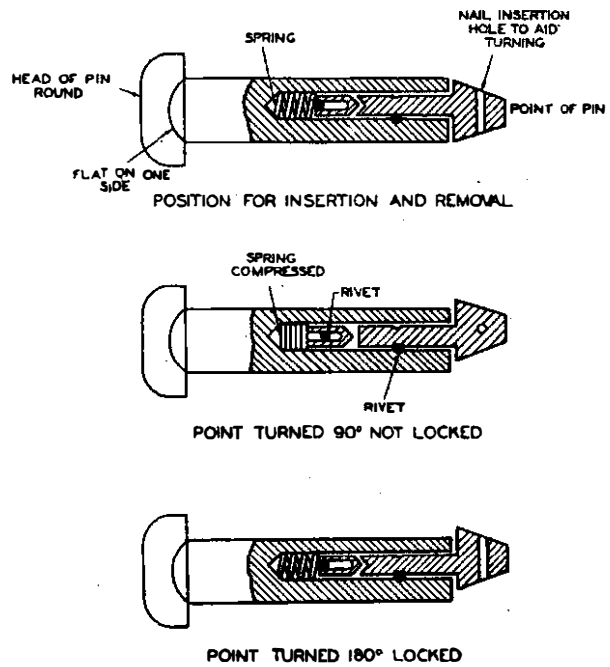

FIG. 7.—ECCENTRIC POINT CONNECTING PIN.

point if it is difficult to turn with the fingers. No cotter pin need be used with this type of pin, which can be used as a locking pin in telescopic members such as derrick legs, truck jacks and for many similar purposes.

Wire Tensioning Tongs (Fig. 8)

This tool is called by the American Army the "Come along," and comprises a grasshopper lever

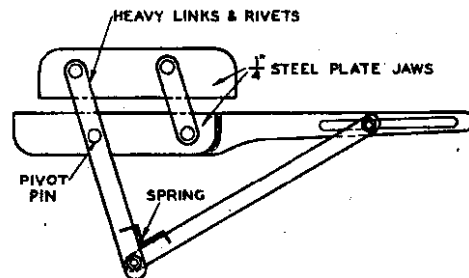

FIG. 8.—WIRE TENSIONING TONGS.

link jaw of robust design at each extremity connected by a sash line through a system of blocks and sheaves giving treble purchase.

The tool as it is might be very useful on long straight lines when pulling up slack on both sides of a central pole, but P.O. workmen found the sash line very cumbersome to use, and on account of terminations which are apparently not so frequently used in the U.S.A. it was often impossible to use the tool as intended.

The point of special interest, however, is the jaw.

Its main features are :—

- (i) Extra length of jaw plus parallel action and long lever beyond pivot pin gives better grip, and this tool will not slip on new 40 lb. cadmium copper wire as did older P.O. types with semi-circular grooves.
- (ii) Robust construction resists wear and damage.
- (iii) Stout rivets and links close together prevent wires, particularly 40 lb., getting wedged

between jaw and link after a short period of use.

- (iv) Spring in grasshopper lever link keeps jaws locked on wire while adjusting vice in position.
- (v) One vice of this design (jaw portions only) can be used for several different gauges of conductor, thus saving tools, weight and space on vehicles.

Conclusion

In conclusion may it be stated that the material benefit derived from association with our American friends was not the only consideration in this venture. Their voluntary and ready assistance, coming as it did after three years of war from newcomers fresh in the fight, filled with enthusiasm and a keenness to get things moving, was a tonic to our spirits which was much appreciated.

Book Review

"Electric Power System Control." By H. P. Young, M.I.E.E., M.A.I.E.E. 319 pp. 214 ill. Chapman & Hall, 25s. net.

This book is the first edition of a further volume in the publisher's series of monographs on electrical engineering and the author is the general editor of the series.

The book begins by dealing shortly with the parallel operation of D.C. generators and at greater length with A.C. machines; this is followed in the second chapter by the voltage control of A.C. generators covering exciter and generator instability and methods of automatic voltage control. This last subject is continued in the next chapter in which the Brown Boveri, Metropolitan Vickers, carbon pile and electronic automatic voltage regulators are dealt with in detail. Chapter 4 deals with automatic synchronising of A.C. generators, two methods being described in detail. The fifth chapter discusses the short-circuit capacity of A.C. generators and short-circuit currents, following on to the use of reactors; types of reactors are described briefly and their installation in generator and feeder circuits and between busbar sections is dealt with. Vector diagrams are used freely here and throughout the book. A chapter on circuit breakers follows next and after some notes on arc extinction, some types of oil circuit breakers are described. The air blast circuit breaker, a type which has been developed to a considerable extent abroad and in which greater interest is now being taken in this country, is mentioned briefly, as are H.R.C. fuses. Power station

switch gear arrangements, sectioning busbars and the calculation of short-circuit current for several specific systems assuming symmetrical three-phase short-circuits are also dealt with. Chapters 8 and 9 deal respectively with the inter-connection of power stations and with the apparatus for inter-connector control including the conditions for transfer of load between stations, voltage control by tap changing, static boosters and induction regulators. The last chapter describes methods of automatic supervisory control and of remote metering permitting control over a system to be exercised from one central point; in this the uniselector plays a considerable part.

The aim of this series is the presentation of the up-to-date outlook on each subject, condensed into a volume of moderate size. In doing this the author of the present volume has drawn upon I.E.E. papers, information furnished to him by manufacturers and other sources and the present volume shows that he has exercised the wisdom and judgment in the choice of material that the successful attainment of this aim requires. The book is an excellent summary of the present position in this branch of electrical engineering and should be of value both to engineers actually engaged in it and to others who wish to keep abreast of modern practice and, as might be expected from its author, it is written in a style that makes it very suitable for students. Its mathematics do not go beyond simple calculus and its production is excellent.

H. R. M.

Notes and Comments

Roll of Honour.

The Board of Editors deeply regrets to have to record the deaths of the following members of the Engineering Department :—

While serving with the Armed Forces, including Home Guard

Bournemouth Telephone Area	Coles, S. A.	... Skilled Workman, Class II	... Flying Officer, Royal Air Force
Bradford Telephone Area ...	Kidwell, J. A.	... Unestablished Skilled Workman	Driver, Royal Artillery
Brighton Telephone Area ...	Barrett, C. R.	... Draughtsman, Class II...	... Flight Lieutenant, Royal Air Force
Brighton Telephone Area ...	Redford, L. H.	... Unestablished Skilled Workman	Sergeant, Royal Air Force
Brighton Telephone Area ...	Temple, R.	... Unestablished Skilled Workman	Signalman, Royal Corps of Signals
Cambridge Telephone Area	Jenkinson, L.	... Unestablished Skilled Workman	Sergeant, Parachute Battalion
Edinburgh Telephone Area	Murdoch, W.	... Skilled Workman, Class II	... Sergeant, Royal Corps of Signals (Airborne)
Engineering Department ...	Franklin, G.	... Assistant Engineer	... Lieutenant, Royal Corps of Signals
Engineering Department ...	Hastings, C. P.	... Motor Cleaner	... Trooper, Hussars
Engineering Department ...	Maynard, G. E. C.	... Unestablished Skilled Workman	Lieutenant, Royal Corps of Signals
Engineering Department ...	McHugh, S.	... Skilled Workman, Class I	... Pilot Officer, Royal Air Force
Engineering Department ...	Plant, F. S., M.M.	... Motor Mechanic...	... Sergeant, Royal Corps of Signals
Exeter Telephone Area ...	Strong, R. A.	... Skilled Workman, Class II	... Gunner, Royal Artillery
Gloucester Telephone Area	Hatfield, G.	... Unestablished Skilled Workman	Signalman, Royal Corps of Signals
Gloucester Telephone Area	Kirton, J. E. W.	... Unestablished Skilled Workman	Acting Leading Airman, Fleet Air Arm
Gloucester Telephone Area	Talbot, W. A. J.	... Unestablished Skilled Workman	Signalman, Royal Corps of Signals
Lancaster Telephone Area...	Higgins, A.	... Skilled Workman, Class II	... Private, Royal Electrical and Mechanical Engineers
Leeds Telephone Area ...	Marshall, L. D.	... Skilled Workman, Class II	... Lance Corporal, Royal Corps of Signals
Liverpool Telephone Area...	Good, C. A.	... Skilled Workman, Class II	... Sergeant Pilot, Royal Air Force
Liverpool Telephone Area...	Hulme, R.	... Inspector	... Sergeant Pilot, Royal Air Force
Liverpool Telephone Area...	Irwin, W. G.	... Unestablished Skilled Workman	Signalman, Royal Corps of Signals
Liverpool Telephone Area...	Lunt, J. J.	... Inspector	... Signalman, Royal Corps of Signals
London Postal Region ...	Burke, J.	... Skilled Workman, Class I	... Chief Engine Room Artificer, Royal Navy
London Telecommunications Region	Bailey, N. F.	... Skilled Workman, Class II	... Sergeant, Royal Air Force
London Telecommunications Region	Baker, F. J.	... Labourer...	... Able Seaman, Royal Navy
London Telecommunications Region	Burrige, T.	... Unestablished Skilled Workman	Fusilier, Royal Fusiliers
London Telecommunications Region	Cornish, F. D.	... Unestablished Skilled Workman	Signalman, Royal Corps of Signals
London Telecommunications Region	Cox, W. A.	... Skilled Workman, Class II	... Corporal, Queen's Own Royal Regiment
London Telecommunications Region	Doughty, A. W.	... Unestablished Draughtsman	... Flight Sergeant, Royal Air Force
London Telecommunications Region	Freeland, W. E. G.	... Labourer...	... Signalman, Royal Corps of Signals

London Telecommunications Region	Greengrass, L. C.	Labourer...	Private, Norfolk Regiment
London Telecommunications Region	Haddock, A. L.	Skilled Workman, Class II	Private, Home Guard
London Telecommunications Region	Hankins, C. A.	Labourer...	Stoker, Class I, Royal Navy
London Telecommunications Region	Horner, R. W.	Unestablished Skilled Workman			Gunner, Royal Artillery
London Telecommunications Region	Hyland, N. A.	Skilled Workman, Class II	S/Sergeant, Royal Electrical and Mechanical Engineers
London Telecommunications Region	Lees, M.	Unestablished Skilled Workman			Sergeant, Royal Air Force
London Telecommunications Region	Lines, G. C.	Skilled Workman, Class II	Signalman, Royal Corps of Signals
London Telecommunications Region	Orridge, G. W.	Labourer...	Private, King's Own Scottish Borderers
London Telecommunications Region	Swettenham, R. V.	Unestablished Skilled Workman			Lieutenant, Royal Corps of Signals
London Telecommunications Region	Wallington, L. J.	Unestablished Skilled Workman			Signalman, Royal Corps of Signals
London Telecommunications Region	Watson, D. M.	Youth-in-Training	Leading Aircraftman, Royal Air Force
London Telecommunications Region	White, C.	Labourer...	Able Seaman, Royal Navy
London Telecommunications Region	Williams, F. W.	Unestablished Skilled Workman			A/Sergeant, Royal Corps of Signals
London Telecommunications Region	Wilson, R. B.	Skilled Workman, Class II	Sergeant, Rifle Brigade
Manchester Telephone Area	Carberry, J.	Inspector	Engineer Artificer, Royal Navy
Manchester Telephone Area	Morrison, W.	Unestablished Skilled Workman			Able Seaman, Royal Navy
Manchester Telephone Area	Stopford, N. G.	Skilled Workman, Class II	Sergeant, Royal Air Force
Newcastle-on-Tyne Telephone Area	Deed, S. V.	Youth-in-Training	Sergeant Navigator, Royal Air Force
Norwich Telephone Area	Frostick, F. R. W.	Unestablished Skilled Workman			Leading Aircraftman, Royal Air Force
Norwich Telephone Area	Grant, C. C.	Labourer	Driver, Royal Army Service Corps
P.O. (London) Railway	Cowan, H.	Labourer...	Corporal, Royal Northumberland Fusiliers
Sheffield Telephone Area	Boardman, C.	Unestablished Skilled Workman			Signalman, Royal Corps of Signals
Sheffield Telephone Area	Goodhand, H. H.	Skilled Workman, Class II	Signalman, Royal Corps of Signals
Shrewsbury Telephone Area	Russell, D. H.	Inspector	Signalman, Royal Corps of Signals
Southampton Telephone Area	Jones, T. G.	Labourer...	Leading Naval Airman, Fleet Air Arm

Recent Awards.

The Board of Editors has learnt with great pleasure of the honours recently conferred on the following members of the Engineering Department :—

While serving with the Armed Forces, including Home Guard

Birmingham Telephone Area	Beard, D. R.	Skilled Workman, Class II	Flight Sergeant, Royal Air Force	Distinguished Flying Medal
Engineering Department	Plant, F. S.	Motor Mechanic	P/A Sergeant, Royal Corps of Signals	Military Medal
Leicester Telephone Area	Harris, S. H.	Unestablished Skilled Workman	Able Seaman, Royal Navy	Mentioned in Despatches

Birthday Honours

The Board of Editors offers its congratulations to the following members of the Engineering Department who have been honoured by H.M. the King in the recent Birthday Honours List:—

Mr. P. J. Ridd	.. Deputy Engineer-in-Chief	Commander of the Order of the British Empire
Mr. T. H. Flowers	.. Executive Engineer, Engineering Department	..	Member of the Order of the British Empire
Mr. S. A. Hobbs	.. Skilled Workman, Class I, Bristol	British Empire Medal
Mr. H. Miller	.. Inspector, Lincoln	British Empire Medal

Colonel N. F. CAVE-BROWNE-CAVE.

Post Office Engineers throughout the country will learn with regret of the death of Col. N. F. Cave-Browne-Cave at the age of 58.

Malvern College; Birmingham University; Stafford, Hanley and Birmingham Engineering Sections; Foreign service with the Royal Engineers (Signals); mentioned in despatches; Birmingham Test Branch; Eastern Engineering District; American Commission; Telecommunications Investigation Group; and lastly—Deputy Regional Director, Home Counties Region and Zone Commander, Post Office Home Guard, such is the outline of Cave's lifetime of energetic and devoted service.

As chairman of numerous Engineering Headquarters Committees—which he handled with a rare combination of tact, patience and good humour—he showed a thorough grasp of fundamentals whilst his original thinking was an inspiration to his colleagues. His belief in the value of training was unshakable. His capacity for devising and digesting statistics enabled him to detect weaknesses in management with an accuracy little short of wizardry—weaknesses which he would pursue with a tenacity aptly phrased in the family motto, "Cave."

One of the original Local Defence Volunteers, he threw himself heart and soul into the heavy task of organising the 8,000 members of the Home Counties Zone of the P.O. H.G. which he commanded.

Cave served on the Council of the I.P.O.E.E. and contributed more than a dozen papers on widely differing subjects. In his day captain of his University cricket and hockey teams, Cave could still play a good round of golf and beat many youngsters at a hard fought game of table tennis. He could string together a number of carefully chosen humorous stories and anecdotes to form a well-balanced and entertaining speech appropriate to the occasion.

Those who knew him well will remember not least the human qualities which lay beneath the transparent mask of a disciplinarian who asked of his subordinates no more than he gave himself. They will remember his sincere regard for the well-being of his staff, his sympathetic consideration for personal and domestic difficulties and his encouragement to the disappointed.

The untimely death of his only son Roger, with the R.A.F. at Singapore, was a cruel blow which he bore with magnificent fortitude—a fortitude which enabled him to write a few days before his death. "My courage is well up."
L. G. S.

Regional Notes

Home Counties Region

IN THE FRONT LINE

No doubt many of the Female Engineering Assistants now employed on P.O. Engineering work are familiar with sneak raiders with their bombs and machine guns as they go about their daily work, but it is hoped that the experience that befell one of the F.E.A.'s employed in the Portsmouth Area will not become too common.

This F.E.A. in company with a S.W.2 fitter, had been installing some apparatus in a "secret" establishment situated on the outskirts of a much-bombed small coastal town, and were returning over a cliff road in a small P.O. van. As motorists will appreciate, they did not realise that an "alert" was on as they travelled along, and the first intimation they had of "imminent danger" was a swooping attack by a fast raiding plane, firing cannon shells at their vehicle. The vehicle was struck repeatedly and soon the S.W.2 fitter, who was driving, was struck in the shoulder by one of these substantial missiles, losing control of the van, which was overturned. Fortunately, assistance was available, and the fitter and his assistant were extricated, the former obviously badly hurt and unconscious. The F.E.A. despite the shock of the occurrence, and the fact that she sustained several

"splinter" wounds, assisted in the removal of her workmate, and, what is more remarkable, had the presence of mind and high sense of duty to remove from the van some confidential diagrams and papers relating to the "secret" establishment where they had been working. She retained personal custody of these papers until visited in the hospital by her inspector later in the day. It is thought that many of her colleagues all over the country will be pleased and proud to read this short account of a very praiseworthy action.

F. J. G.

A VETERAN EXCHANGE

On the 16th April, 1916, when the last Great War was settling down to the stalemate on the Western Front, and November 11th, 1918, with its glorious climax was still hardly visualised by even the most "wishful" thinkers, Portsmouth telephone exchange was opened for service. Little did any of the staff at that time (and two or three venerable gentlemen are still serving in the Area) imagine that the same installation, with certain additions and modifications, would be working during an ever greater world catastrophe twenty-seven years later.

The installation was one of the first automatic switching systems to be put into service in a large town. The

individual subscribers' equipment at the exchange end was Keith line switches, and the two selectors and connector (as the finals were then described) were the open type of switch with the relays mounted on various knobby excrescences all over the switch frame. During the early years, communications engineers from practically every country in the world came to wonder at the robot gyrations of these switches. Japanese, Chinese, Siamese and Indians, Americans, French, yes, and Germans, all testified, in the visitors' book, to the wonders of the new system. All of the Engineers-in-Chief of the G.P.O., from Sir William Slingo to Sir William Purves, visited the installation in their official capacity some time or another, and, on one occasion, no fewer than nine superintending engineers arrived in a body to inspect the plant.

After some time, naturally, its pristine glory faded, and in the years 1932-33 a major overhaul was instituted during which some thousands of relay springs were changed, thousands of yards of new wiper cords were fitted, and numerous relay coils and mechanical parts, worn by sixteen years of hard work on the public service, and, not unimportant this, in training a nucleus of auto switchmen, were replaced. Progressive efforts at modernisation were made at various intervals, such as the application of "tones" the introduction of the "eleventh step," and the automatic routiner. It must be recorded that the old installation did not seem to take kindly to these and other innovations. In some respects it was like fitting a Parsons turbine into H.M.S. Victory.

The outbreak of the present war stopped work on a much-needed change-over to a new installation in other premises. Naturally, some difficulty has been experienced with certain of the rather archaic circuit features, such as the Keith line switches and the master switches that control them, during the war years. Even in peace time the "spare part" situation in respect of some of these components was rather precarious, and these difficulties have been accentuated by the war. In addition to this, the building the apparatus is housed in has been well shaken and blasted by enemy action, much to the detriment of the ancient apparatus and wiring. So once again another drive to resuscitate the installation by a thorough overhaul and a judicious use of the small quantity of replacement parts that are available is in progress. Sufficient has been done to effect some appreciable measure of improvement, although a reduction in the number of exchange faults to a figure comparable with that for a modern type installation is rather too much to expect.

F. J. G.

TELEPRINTERS No. 7—RAPID METHODOICAL CHECK OF ADJUSTMENTS

One-day courses of instruction in the salient adjustments scheduled in Table 8 of E.I. Telegraph Teleprinter C 5020 were given at Cambridge Branch of Regional Engineers, H.Q. & S., over the periods 5th-9th and 12th-16th April, 1943. The courses were attended by 105 supervising officers, i.e. Inspectors and higher grades, and the prime object of the instruction was to help supervising officers without previous teleprinter training, to carry out a rapid methodical check of the adjustments vitally affecting the good working of Teleprinters No. 7.

For the purpose of the course a Teleprinter No. 7, Gauges Tension No. 8 and Gauges Feeler No. 3, were provided for each student and each student was given for retention an abridged schedule of adjustments. Demonstrations together with descriptive talks were given and the students were methodically drilled in the

method of carrying out the adjustment checks. The response was extremely good and after practice the average time taken to carry out the methodical check was about five minutes.

Representatives from the Engineer-in-Chief's Training School, who were invited to attend the courses as observers, expressed themselves as favourably impressed.

A schedule of adjustments relating to the Teleprinter No. 3 is being prepared, and, if necessary, a similar course will be provided for those supervising officers who are concerned with Teleprinters No. 3, but who have not attended any of the No. 7 Teleprinter courses already held.

I. H. W.

London Telecommunications Region

WALTHAM CROSS AUTO EXCHANGE

This exchange, of the '2,000' non-director type with subscribers' uniselectors, was opened on the 8th April, 1943. 1,221 subscribers' direct exchange lines and 159 incoming and outgoing junctions were transferred from the existing manual C.B.S. No. 1 exchange, which was the last of its kind in the North Area. Equipment for 2,100 subscribers' lines (multiple) has been provided. The power plant is of the parallel battery automatic charge type. Each battery has a capacity of 800 Ah. The manual board circuits are terminated on the Tottenham automatic exchange.

On the day prior to the transfer a gale arose which increased to a velocity of 70 miles per hour and caused considerable damage to the subscribers' line plant. Over 90 per cent. of the subscribers in this area are served overhead. Urgent and special arrangements had to be implemented forthwith; but due to the commendable energy and zeal displayed by the external staff concerned and the co-operation of the internal testing staff who had to deal with abnormal demands made for testing and fault localisation on the day of the opening of the auto exchange, the transfer was brought to a successful conclusion.

The auto equipment was manufactured and installed by Standard Telephones and Cables, Limited. The batteries were provided by the Hart Accumulator Company, Limited.

H. A.

LONDON TRUNK EXCHANGE AND REPEATER STATION

The opening on the 21st November, 1942, of the first two suites, comprising 76 positions, of a total of six suites of a new trunk exchange, test room, and repeater station in a new building, marks the completion of the first stage in the development of this building for reinforcing the long distance communications network.

Exchange.

The ultimate provision will involve suites A to F containing a total of 204 positions. In addition to these, there will be 131 miscellaneous positions, comprising record tables, information desks, directory enquiry, route and rate positions and personal call monitor positions. Suites A—E will be set aside for trunk demand calls and suite F for incoming trunk circuits. Both the incoming and outgoing suites of positions will be virtually an extension of the existing trunk exchange situated in Faraday North Building. This has involved the provision of direct external cables to link up outgoing multiples and calling appearances in the various exchanges necessitating the provision of 21 external tie cables, containing 2-wire, 3-wire and 4-wire connections, to give full flexibility in certain trunk exchanges. When

the final stage of completion has been reached, there will be a total of 1,059 positions set aside for the trunk demand service.

The following types of circuits have been connected to the new exchange :

Outgoing and Bothway Trunk circuits ...	550
" " Toll " ...	91
" 4-digit Junctions ...	98
" Manual Junctions ...	102
Manual Board 1st Code Selectors ...	60
Incoming Auto. Junctions ...	322
Incoming Manual Junctions ...	102
Trunk Lending Lines outgoing ...	30
Trunk Lending Lines incoming ...	26

Test Room.

The new trunk test room is a separate controlling testing office with 12 trunk test racks, 3 junction test racks and 3 trunk and junction record positions with busy-key facilities. The trunk test racks are equipped with A.C. testing apparatus to enable the test clerks to perform the full D.C. and A.C. duties and thus relieve the repeater station of routine testing and other A.C. testing duties. Owing to the complexity of faulting arrangements between the various trunk exchange switchrooms, 2 V.F. auto. and trunk 7-digit auto equipment, embracing scattered test rooms and repeater stations, a special faulting procedure has been introduced centralised in the fault clearance record officer. This officer is provided with telephone facilities to the various fault control centres and is in a position to note the disposition of all faults in hand at any time of the day:

Repeater Station.

The transmission portion of this equipment is of the latest type and consists of transformer and line corrector racks and Panels Amplifying No. 32, with the associated terminating, signalling and testing equipments. 88 groups of Carrier System No. 2 have also been transferred to this station. The Carrier System No. 7 and co-axial equipments will be brought into service at a later stage. There are 2,112 Amplifiers No. 32 and 1,800 4-wire terminations installed at present. Of these approximately 1,800 and 800 respectively have been brought into service.

Power Plants.

The power plant provided and installed for the new Trunk Exchange is a divided battery float system, consisting of two 50-volt batteries, each of 4,000 ampere-hour capacity, three 50 V motor-generator sets, two of 500 ampere output and one of 200 ampere output, with the usual smoothing equipment. The input supply to the motors is 400-volts, 3-phase, 50-cycles. The 200 ampere machine and one of the 500 ampere machines are equipped with automatic voltage regulators.

The repeater station plant consists of 2 motor generator sets, each consisting of an A.C. motor coupled to one A generator and one B generator complete with smoothing equipment. Two A batteries of 3000 ampere-hour capacity are floated at 25-volts and similarly two B batteries of 1300 ampere hours are floated at 130-volts.

Transfer.

Complications in connection with the transfer of circuits to the new equipment were caused owing to the necessity for making comprehensive changes in the layout of the circuits concerned. These involved both cable changes and alterations in the positions of repeater equipments and in this connection approximately 2,000 forms A 886 were received and dealt with. Test rack facilities were not available at the outset—hence it

became necessary to arrange for all circuits to be retained temporarily on the existing test racks for control purposes.

To keep trunk, toll and junction circuits working and to arrange for a smooth change-over without interruption to present services, approximately 90,000 jumpers were provided.

The first cable was transferred to the new equipment on the 7th June, 1942, and since that date the whole of the work has been brought to a satisfactory conclusion within the short period of five months.

W. H. S.

North Eastern Region

ALNWICK TELEPHONE EXCHANGE AND AMPLIFYING STATION TRANSFERS

A new building was completed at Alnwick, Northumberland, shortly after the outbreak of war to house the post office, telephone exchange and amplifier station, each of which at that time was situated in a separate building all within some 150 yards radius of the new building. The transfer from magneto to automatic working was deferred, but the subsequent urgent need for extension and the congested state of the old magneto exchange made it necessary to instal a magneto multiple exchange in the new building, the layout of this equipment being arranged in such a manner as not to interfere with the eventual installation of the automatic exchange. This work was successfully completed and the new exchange opened for service on September 12th, 1942.

Accommodation was not available for equipment extension at the old amplifying station and it was decided to remove the whole of the amplifying equipment (6 Equipments Amplifying No. 20A 20/20; 15 Units Terminating No. 5A; Power Switchboard TL 2596; LT and HT Secondary Cells; 2 Rectifiers No. 35 and 2 Rectifiers No. 36) to the new building. This permitted all external cables to be terminated in their correct positions—a very convenient arrangement for future transfer to auto. A separate suite of 0/480 M.D.F.'s provided for the termination of the temporary magneto exchange, served as an I.D.F. for the new amplifying station, a suitable jumper field being provided between the two frames. This arrangement leaves the whole of the internal side of the M.D.F. free for the contractor's operations when conversion to automatic working takes place. Cable runs have been arranged likewise.

The transfer of working circuits to the new equipment presented no serious difficulties, but careful planning was necessary owing to the shortage of spare pairs in tie cables. The actual transfer operations were carried out over a period of three days and completion was effected without incident.

J. E.

Welsh and Border Counties Region.

SUB-AQUEOUS CABLE REPAIRS

A fault developed on a sub-aqueous cable PCQT. 122/20 R.C. armoured 36/6 .553 miles in length laid across an estuary in the W. & B.C. Region. Precision tests proved the faults to be in the centre of the main channel and a joint which existed at this point was suspected. In order to hold back the penetration of the water at the fault CO₂ was pumped into the cable from both ends. The channel is 28 ft. deep in the centre at low water with a sand and shingle bed. The tides at "Spring" run at 5 knots and are often 18 ft. high.

Assistance from the submarine cable staff was obtained and two motor-boats, one being a converted ship's life-boat and the other a converted pinnace, were hired. These boats were fastened together by light poles lashed athwart them and a hand winch was mounted on a

platform. Grappling for the cable with old anchors enabled a line to be passed under the cable to the winch. Several efforts to raise the cable sufficiently to get it on to a cable sheave fixed on the boats were made without success due to silting, and the weight of the cable. The condition of the boats was such that it was feared that continuation of the attempts to raise the cable by this means might result in damage to the boats or accident to the crews. It was, therefore, decided to pick up the cable where it crossed a mussel bank which at low water was comparatively shallow. This was done and the cable was cut here and sealed. A further cut was made on the shore on the other side of the fault, oil drums were fixed to the ends to act as buoys.

Headquarters, who had been advised of the position, forwarded a 300 yard length of recovered cable PCQT 122/20 R.C. armoured with 60/12 steel wires for cutting out the faulty length. Since the submarine cable staff had been recalled to their ship for other urgent work, it was decided to carry out the job of raising the faulty length and the insertion of the replacing length by Area staff. Some thirty 40-gallon and forty 10-gallon oil drums were obtained and at low tide each day a number of 40-gallon drums were secured to the faulty cable until the drums had raised the cable sufficiently to enable it to be got across one of the boats from bow to stern; the boat was then pulled along the cable and further drums attached at intervals of six yards until the cable was floating.

Incidentally, it was found that only with great difficulty was it possible to release the cable from the sand at the shore end, where apparently a bight had formed in the cable and about a dozen men hauling on ropes and the assistance of the effect of the tide on the boat were necessary to release about four yards of cable from the sand. The cable was finally floated up the estuary at high tide and landed on the quay. The joint was stripped and it was found that the sheath was fractured near both wipes. The cause of these fractures will, no doubt, be decided later, but it is considered that some other method than that adopted should be used for protection of joints in sub-aqueous L.C. and armoured cable. A long coupling in which the armouring on each side of the joint can be clamped and the filling of the coupling with a low temperature compound seems desirable. Although the fault had been on for some time it was found that the water had only penetrated about 20 yards on each side of the joint and 155 yards out of the 200 yards length cut out was recovered in good condition.

The replacing length which had been in use elsewhere, was, during tests for unbalances, etc., found to have a contact in a quad about 60 yards from one end and since it was desired that one of the joints between replacing and existing cable should be on shore above low water, and that more heavily armoured cable should be used in the main channel, it was decided to dig up a 372

yards length from the shore and substitute this for the replacing length. This was done but the cable had to be reversed so that the joint in this length could be situated on shore. This cable was floated across the estuary for a joint to be made at the point of cut at the mussel bank, the end here having been hauled up to a break-water to facilitate jointing which was carried out during the night.

The cable was then floated back across the channel to desired position for sinking and the drums detached. The 240 yards length of 60/12 armoured cable was then floated from the opposite shore about half a mile away, beached, and carried to the trench to take the place of the cable dug up and the final joint made.

A. H. R.

UNUSUAL DUCT OBSTRUCTION

A somewhat unusual duct obstruction which caused some mystification before it was removed was recently encountered in the Cardiff area. The stoppage occurred in a length of single way duct (containing 2 cables—54/40 and 15/10) on a slight down grade and was first noticed when complaints were received that a nearby low-lying cottage was being flooded by a flow of water which appeared to emanate from the P.Q. duct line.

Examination proved that whereas the manhole on the higher end of the length was full of water, and actually overflowing, there was little or no water entering the jointing chamber at the lower end. It was clear that a stoppage somewhere in the length was impeding the flow along the duct and resulted in a water-logging of the ground and consequent ingress of water into the cottage.

A slight obstruction was noticed when the length was rodded and its position was noted, but no difficulty was experienced in pulling through a knotted 3 in. rope.

After these operations had been completed the water flowed freely into the lower jointing chambers and the flooding of the cottage ceased.

Within a few days, however, conditions were as bad as ever and it was decided to break down on the track at the point where the obstruction was felt.

To the foreman's astonishment it was found that a root of a tree on the far side of a substantial stone wall had penetrated the conduit at a duct joint and had swollen out into a matted fibrous mass, completely filling the free duct space for a length of 8 ft. Whilst forming an effective water stopper, the root, owing to its spongy nature, permitted the rods and the rope to pass with little hindrance. The surprising fact is that a growth of this size should have taken place in the three years that the conduit had been laid.

Leaf samples were taken to the Cardiff City Parks Superintendent who identified the tree as a Balsam-Poplar, the roots of which, he said were noted for their powers of penetration and rapidity of growth.

A. B.

Staff Changes

Promotions

Name	Region	Date	Name	Region	Date
<i>Asst. Engr. to Exec. Engr.</i>			<i>Insp. to Chief Insp.—contd.</i>		
Johnson, E. W.	L.T.R.	31.5.43	Fox, G.	W. & B.C. Reg.	1.3.43
<i>Chief Insp. to Asst. Engr.</i>			Nolli, L. M.	N.E. Reg.	21.3.43
Wilcock, A.	E.-in-C.O.	1.4.43	Hough, J. H.	N.W. Reg.	1.4.43
Gormley, L. V.	L.T.R.	7.4.43	Lamb, W. H.	L.T.R.	7.2.43
<i>Chief Insp. to Physicist</i>			Durrant, H. L.	L.T.R.	7.2.43
Paul, W. A. J.	E.-in-C.O.	5.5.43	Worthy, P.	E.-in-C.O.	1.11.42
<i>Insp. to Chief Insp.</i>			<i>Draughtsman Class II to Draughtsman Class I.</i>		
Miller, E. W.	H.C. Reg.	14.3.43	Cooke, F. D.	N.W. Reg. to H.C. Reg.	
Kirk, J. H.	N.W. Reg.	22.2.43	<i>S.W.1 to Insp.</i>		
Sturges, A.	Test Section (Ldn.)	1.3.43	Coombes, R. F.	L.T.R. to E.-in-C.O.	7.4.42
Carter, R. E.	E.-in-C.O. to Test Section (Ldn.)	1.3.43	Goldup, P. H.	E.-in-C.O.	8.4.42
			Stanton, G. H.	Test Section (Bm.)	29.3.43
			Harris, R.	Test Section (London)	18.1.43
			Child, M. R.	E.-in-C.O.	18.4.43
			Ridler, G. H.	E.-in-C.O.	23.4.43
			Bagster, C. J.	Test Section (London)	3.4.43

All promotions acting.

Retirements

Name	Region	Date	Name	Region	Date
<i>Area Engr.</i>			<i>Insp.—c nid.</i>		
Parker, T.	N.E. Reg.	20.5.43	Hamilton, H.	N.Ire. Reg.	24.1.43
<i>Chief Insp. with Allee.</i>			Waugh, J.	Scot. Reg.	31.1.43
Williams, W. A.	L.T.R.	4.5.43	Aitchison, A.	Scot. Reg.	31.1.43
<i>Chief Insp.</i>			Blackie, J. H.	Scot. Reg.	31.1.43
Heighton, C. G.	W. & B.C. Reg.	28.2.43	McLean, A.	Scot. Reg.	31.1.43
Crosse, J.	N.Ire. Reg.	10.3.43	Haig, J.	Scot. Reg.	31.1.43
Waugh, W.	N.E. Reg.	20.3.43	Foster, J. F.	N.E. Reg.	22.3.43
Davey, J.	N.W. Reg.	31.3.43	Tuck, G. E.	H.C. Reg.	21.3.43
Randle, W.	Mid. Reg.	31.3.43	James, W. T.	N.E. Reg.	3.4.43
Mullins, W.	N.W. Reg.	31.3.43	Bunney, C. H. H.	L.T.R.	28.4.43
<i>Insp.</i>			Ward, C. F.	L.T.R.	1.5.43
Biggs, F. J.	L.P.R.	7.1.43	Henderson, H. G.	S.W. Reg.	10.5.43
			King, M. E.	L.T.R.	14.5.43

Deaths

Name	Region	Date	Name	Region	Date
<i>Exec. Engr.</i>			<i>Insp.</i>		
Franklin, G.	E.-in-C.O.	28.5.40-2.6.40	Carberry, J.	N.W. Reg.	22.5.41
<i>Asst. Engr.</i>			Killed on Active Service		
McKinnon, N.	Scot. Reg.	15.4.43	Hulme, R.	N.W. Reg.	8.4.43
			Killed on Active Service		
			Stacey, T. E.	L.T.R.	11.3.43

Transfers

Name	Region	Date	Name	Region	Date
<i>Regl. Engr.</i>			<i>Insp.</i>		
Palmer, W. T.	H.C. Reg. to Mid. Reg.	27.5.43	How, R. C.	L.T.R. to E.-in-C.O.	11.4.43
<i>Asst. Engr.</i>			Myers, A. J.	N.W. Reg. to E.-in-C.O.	27.4.43
Cunningham, J. F.	N.W. Reg. to H.C. Reg.	7.4.43	Ince, W. C.	L.T.R. to Cable Test Section	1.5.43
Sherriff, L.	E.-in-C.O. to S.W. Reg.	7.5.43	Harbord, E. G.	E.-in-C.O. to H.C. Reg.	1.6.43

Appointments

Name	Region	Date	Name	Region	Date
<i>Insp. to A.T.S.</i>			<i>Insp. to A.T.S.—con'd.</i>		
Daniel, R. G.	H.C. Reg. to L.T.R.	13.1.42	Oates, L. A. J.	S.W. Reg.	19.1.43

Book Review

"Switchgear Practice." By Arthur Arnold, A.M.I.Mech.E., A.M.I.E.E. 238 pp. 133 ill. Chapman & Hall, 22s. net.

The design and construction of electrical switchgear has developed greatly during recent years concurrently with the increase in severity of the conditions it has to meet, and a book setting out the present practice will be welcomed by the many users who are not specialists in this work. The book begins with normal and specialised D.C. circuit breakers, goes on to D.C. motor starters of various types and the methods of controlling their rate of action, and then to D.C. switchboards dealing with general details of generator and feeder panels and battery switchgear. A chapter on A.C. motor starters follows, succeeded by one on A.C. busbar layout. Chapter 8 deals with types of A.C. switchgear, cubicle, truck, draw out, etc., and with neutral switching and the following chapters with heavy duty circuit breakers (giving very briefly the theory of arc control), isolators, and interlocks, including the Castell

Key method. Switchgear testing, protective devices, instrument and control boards are also dealt with and there are chapters on lightning arrestors and fire protection; oil-less circuit breakers are dealt with briefly. B.S. specifications referring are quoted and there is a bibliography of recent articles, papers and reports. The illustrations include some photographs of apparatus and a number of schematic line diagrams showing the principles of apparatus and layouts.

This volume is eminently a practical work dealing mainly with the requirements to be met and the principles on which the types of apparatus have been built to meet these requirements; it does not deal with design, calculations, short-circuit current, etc. The engineer who requires to know practical points involved in the choice and arrangement of switchgear will find this book of great value as should the student engaged on practical work and who wishes to know the why and wherefore of the design of the apparatus he sees in use.

H. R. M.

BOARD OF EDITORS

A. J. GILL, B.Sc., M.I.E.E., F.I.R.E., Chairman.
F. E. NANCARROW, A.R.C.Sc., M.I.E.E.
P. B. FROST, B.Sc., M.I.E.E.
A. H. MUMFORD, B.Sc.(ENG.), M.I.E.E.
C. W. BROWN, A.M.I.E.E.
G. H. S. COOPER.
H. LEIGH, B.Sc.(ENG.), A.M.I.E.E., Acting Managing Editor.
G. E. STYLES, A.M.I.E.E., Acting Assistant Editor.
A. J. BAKER, Secretary-Treasurer.

Copyright

The entire contents of this JOURNAL are covered by general copyright, and special permission is necessary for reprinting long extracts, but Editors are welcome to use not more than one-third of any article, provided credit is given at the beginning or end thus: "From the *Post Office Electrical Engineers' Journal*."

The Board of Editors is not responsible for the statements made or the opinions expressed in any of the articles in this JOURNAL, unless such statement is made specifically by the Board.

Communications

All Communications should be addressed to the Managing Editor, *P.O.E.E. Journal*, Engineer-in-Chief's Office, Alder House, Aldersgate Street, London, E.C.1. Telephone: HEADquarters 1234. Remittances should be made payable to "*The P.O.E.E. Journal*" and should be crossed "& Co."

Binding Cases

Cases for binding are available, and may be obtained from the Local Agents for 1s. 0d. Subscribers can have their copies of Volumes bound, at a cost of 3s., by sending the complete set of parts to the Local Agents or to the *P.O.E.E. Journal*, Engineer-in-Chief's Office, Alder House, Aldersgate Street, London, E.C.1. Orders for binding for Vols. 1-19 should indicate whether the original binding case with black lettering, or the later pattern with gold, is required. Cases with gold lettering are the only type stocked from Vol. 20 onwards.

Back Numbers

The price of the JOURNAL, which is published quarterly, is 1s. (1s. 3d. post free) per copy, or 5s. per annum post free. Back numbers can be supplied, subject to availability of stocks, at 1s. each (1s. 3d. post free). Orders for back numbers may be sent to the Local Agents or to the Publishers.

Advertisements

All communications relating to space reservations should be addressed to the Advertisement Editor, *P.O.E.E. Journal*, Alder House, Aldersgate Street, London, E.C.1. Communications regarding advertisement copy, proofs, etc., should be addressed to the Publishers, Messrs. Birch & Whittington (Prop. Dorling & Co. [Epsom], Ltd.), 49 Upper High Street, Epsom, Surrey.



The AvoMeter is one of a useful range of "Avo" electrical testing instruments which are maintaining on active service and in industry the "Avo" reputation for an unexcelled standard of accuracy and dependability—in fact, a standard by which other instruments are judged.

ONE INSTRUMENT

measures :—
 Current, A.C. and D.C. (0 to 10 amps.)
 Voltage, A.C. and D.C. (0 to 1,000 v.)
 Resistance (up to 40 megohms)
 Capacity (0 to 20 mfd.)
 Audio-frequency Power Output (0 to 4 watts)
 Decibels (—10 Db. to + 15 Db.)

Some delay in delivery of Trade Orders is inevitable, but we shall continue to do our best to fulfil your requirements as promptly as possible.

'AVO'
 Regd. Trade Mark

Meters that Matter

THE Model 7 Universal AvoMeter is the world's most widely used combination electrical measuring instrument. It provides 46 ranges of readings and is guaranteed accurate to B.S. first grade limits on D.C. and A.C. from 25 to 100 cycles. It is self-contained, compact and portable, simple to operate and almost impossible to damage electrically. It is protected by an automatic cut-out against damage through severe overload, and is provided with automatic compensation for variations in ambient temperature.

Sole Proprietors and Manufacturers

THE AUTOMATIC COIL WINDER & ELECTRICAL EQUIPMENT Co. Ltd.
 Winder House, Douglas Street, London, S.W.1
 Phone : VIctoria 3404-7

★ *When considering additions to your Laboratory — or components for your new designs — consult MUIRHEAD.*

FOR RESISTANCE NETWORKS. PRECISION CONDENSERS. BRIDGES AND ACCESSORIES. OSCILLATORS & WAVEMETERS. TIMING DEVICES AND FREQUENCY STANDARDS

COMPONENTS : MICA & PAPER CONDENSERS. SLOW MOTION DRIVES SWITCHES OF ALL TYPES. TRANSFORMERS. SCREENED LEADS, ETC.

MUIRHEAD & COMPANY LIMITED, ELMERS END, BECKENHAM, KENT. TELEPHONE: BECKENHAM 0041-2

MUIRHEAD

FOR OVER 60 YEARS DESIGNERS & MAKERS OF PRECISION INSTRUMENTS

PROGRESS IN TELEPRINTER TRANSMISSION

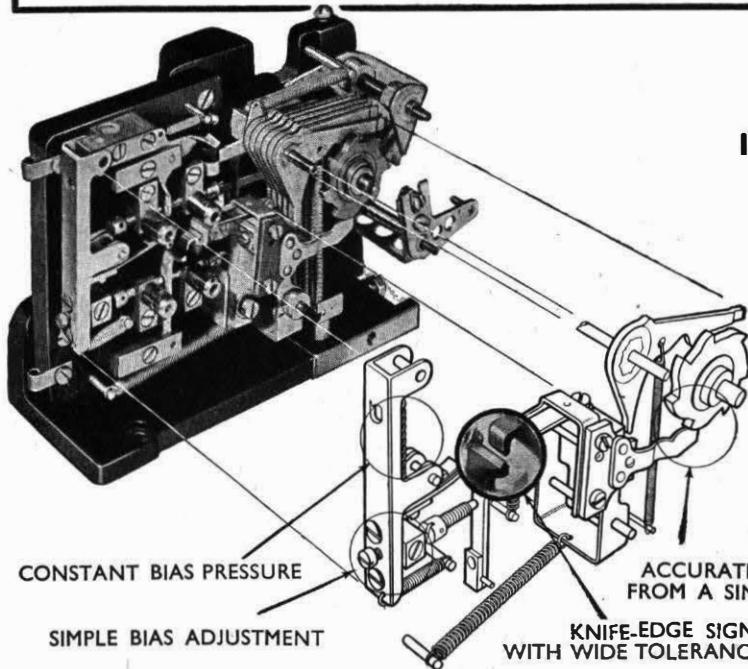

**IMPROVED PERFORMANCE WITH
REDUCED MAINTENANCE**

THE NEW CREED TELEPRINTER TRANSMITTING UNIT S2184

CONSTANT BIAS PRESSURE

SIMPLE BIAS ADJUSTMENT

ACCURATE TIMING
FROM A SINGLE CAM

KNIFE-EDGE SIGNAL SELECTION
WITH WIDE TOLERANCE OF BIAS VARIATION

CREED & COMPANY LIMITED  TELEGRAPH HOUSE, CROYDON

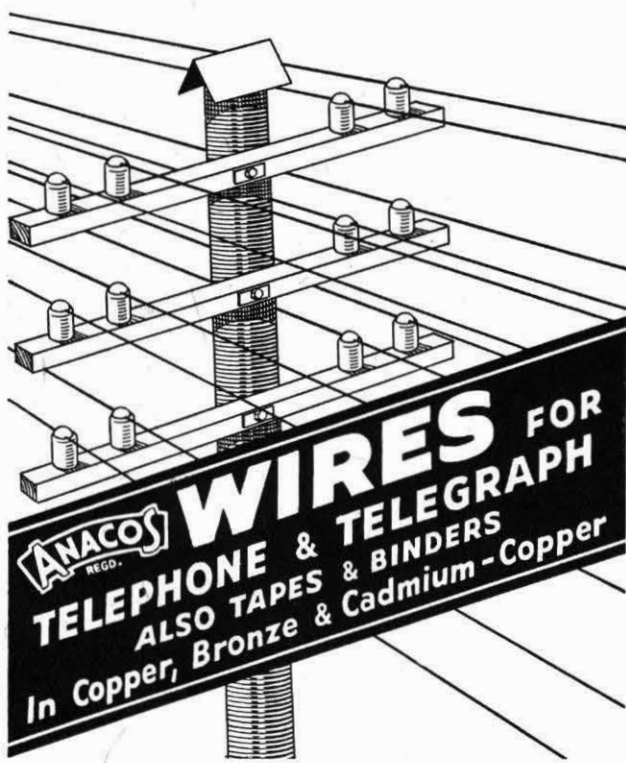

ANACOS WIRE REGD.
**WIRES FOR
TELEPHONE & TELEGRAPH**
ALSO TAPES & BINDERS
In Copper, Bronze & Cadmium-Copper

FREDERICK SMITH & CO. LTD. (Incorporated in The London Electric Wire Company and Smiths, Limited.)
ANACONDA WORKS, SALFORD, 3, LANCS.
Telephone : BLACKFRIARS 8701 (8 lines) Telegrams : 'ANACONDA' MANCHESTER

Tenaplas

EXTRUDED PLASTICS

will play a large part in post-war developments and the Tenaplas process opens up many possibilities for the enterprising manufacturer. Tenaplas Specialists can extrude plastic coverings of dimensional accuracy, in a variety of colours to wire, rope and other flexible materials. Perhaps your products could be improved by the help of Tenaplas. Why not ask their advice ?

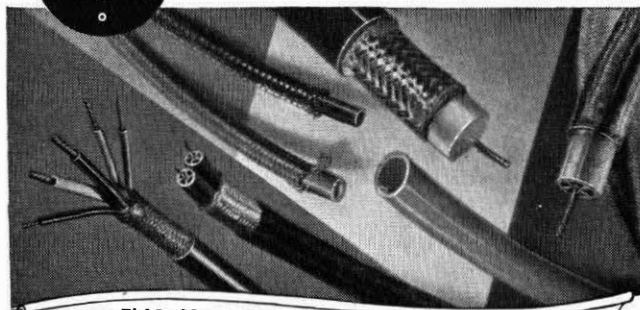

TENAPLAS LTD., Head Office, 7 PARK LANE LONDON. W. 1.

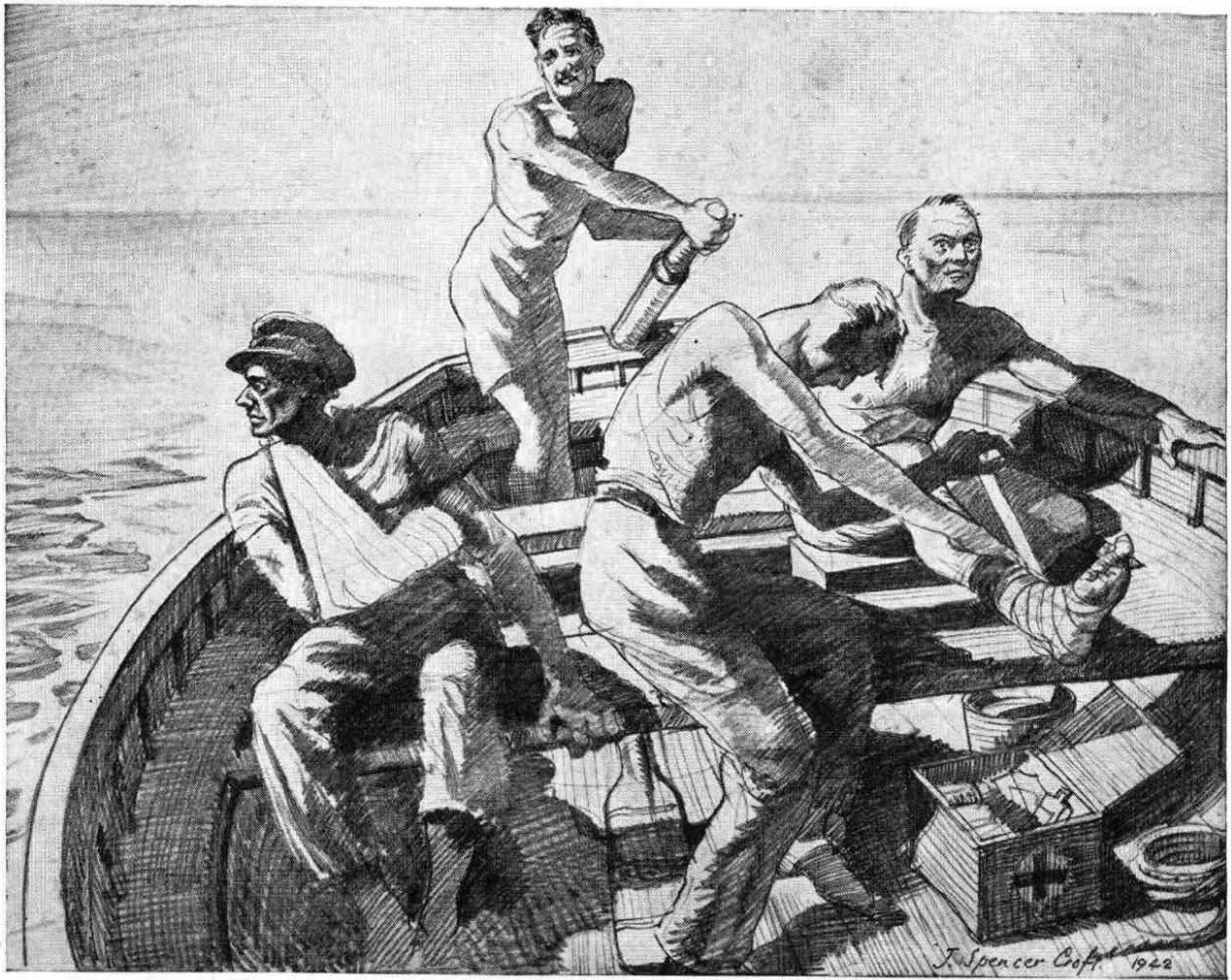

S.S. "Anglo Saxon," sunk mid-Atlantic, August 21st, 1940.

Seven men left the sinking ship, smashed by a German raider. Most of them were wounded, some gravely. As the mate wrote in the log, they had "British Determination," but their needs were great and their equipment was inadequate—a small boat, little first-aid kit, practically no food and only three gallons of water. Wounds and weather, hunger and thirst claimed five of them. After seventy terrible days—sailing more than 2,000 miles—two were saved. Their adventures live as an epic of the sea.

This announcement is a tribute to the bravery of these and many other gallant souls whose stories of battling against adversity with inadequate equipment will never be told.

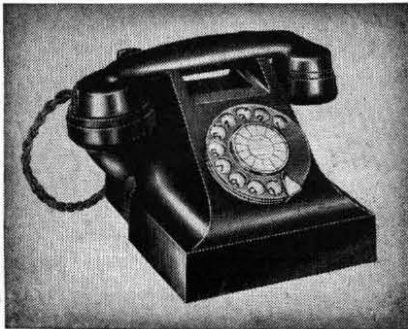

The Will alone is not enough—

Need is the measure of the value of equipment . . . The re-organisation which will inevitably have to be undertaken in all countries after the war will be rendered immeasurably more difficult if there is failure to recognise the importance of telecommunications. But the will alone is not enough . . . to enable restoration plans to be promptly co-ordinated, Telephone, Carrier and Radio equipment will have to be brought into service in the shortest possible time. Those State or private concerns which possess Strowger Automatic Telephone equipment will be particularly fortunate, for even though exchanges may have been damaged or denuded of parts for military communications, the standardised nature of the apparatus facilitates speedy rehabilitation. This same quality enables the rapid manufacture and installation of new exchanges wherever such may be necessary. For expert advice on every phase of telecommunications, consult



Automatic Telephone & Electric Co. Ltd.

L O N D O N & L I V E R P O O L

Manufacturers of · Strowger Automatic Telephone Equipment · Carrier Current and Transmission Equipment · Street Traffic Signals · Street Fire Alarm Apparatus · Supervisory Remote Control Equipment for Power Networks · Mine Telephones and Signalling Apparatus, etc

FOR JOBS OF NATIONAL IMPORTANCE

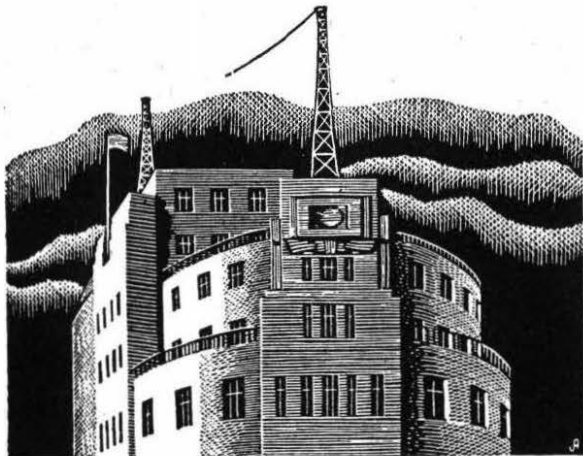

THEY CHOOSE

TUDOR

ACCUMULATORS

Tudor Accumulators are doing a big job in the control room of Broadcasting House, and in many other places all over the country Tudor Accumulators are relied upon for jobs of high importance. In many of Britain's power stations, for instance, Tudor Accumulators are installed. Where complete reliability is essential, therefore, no better choice can be made than Tudor.

SAFETYLYTE

(Licensed under Patent No. 313248). The Tudor Emergency Lighting System completely meets the risk of a sudden plunge into darkness. Should the normal supply be interrupted through causes beyond the control of Electricity Undertakings, the control panel that keeps the Tudor Accumulator charged automatically brings it into circuit.

THE TUDOR ACCUMULATOR CO., LTD.
50 GROSVENOR GARDENS, LONDON, S.W.1
Telephone: SLOane 016819. W.T.6



Chemical analysis plays an essential part in the selection of suitable material for use in WESTINGHOUSE PRODUCTS.

One process carried out in our laboratories is volumetric analysis of tin content in a non-ferrous alloy by titration.

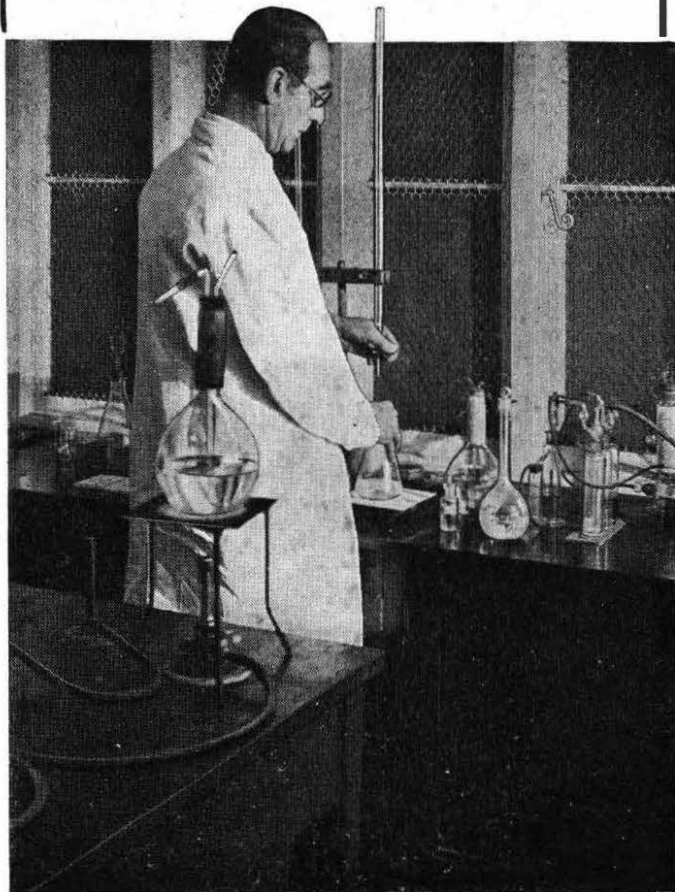

Though Westinghouse Rectifiers are unfortunately in short supply, the groundwork of research and experiment is laying the foundation of the advanced Rectifiers of tomorrow. May the day soon dawn when these Rectifiers once more will be available for all uses.

*Westinghouse
Rectifiers*

**WESTINGHOUSE BRAKE & SIGNAL CO. LTD.,
PEW HILL HOUSE,
CHIPPENHAM, WILTS.**

SIEMENS PRODUCTS

backed by over 80 years' Electrical Experience

Contractors for
the manufacture, laying and main-
tenance of Submarine and Land
Cables for Telegraphy, Telephony
and the Electric Transmission of
Power, for the erection and main-
tenance of Overland Telegraph,
Telephone and Power Transmission
Lines, Marine Wireless Telegraph
and Telephone Installations, Public
and Private Telephone Exchanges
and Carrier Equipment for
Telephone Lines.

Manufacturers of

Electric Lamps of all types for
Domestic, Industrial and Street
Lighting, including "Sieray" Electric
Discharge Lamps, Fluorescent Tubes,
Motor Car Lamps, Projectors, etc.



**ELECTRIC
WIRES & CABLES**

**CABLE
JOINT BOXES**

TELEPHONE CABLES
Aerial, Underground, Submarine

**OVERHEAD
LINE MATERIAL**

CELLS & BATTERIES
Dry, Fluid & Inert

**ELECTRICAL
MARINE APPARATUS**

**ELECTRIC
LAMPS**

**PRIVATE
TELEPHONE SYSTEMS**

**PUBLIC
TELEPHONE EXCHANGES**

**CARRIER-CURRENT
EQUIPMENT**

**WIRELESS EQUIPMENT
FOR SHIPS**

"ZED" FUSES
L.T. SWITCH & FUSE GEAR

SIEMENS BROTHERS & CO., LTD.
WOOLWICH, LONDON, S.E. 18

SIEMENS ELECTRIC LAMPS & SUPPLIES LTD., 38-39 UPPER THAMES STREET, LONDON, E.C. 4



The War has not been allowed to interfere with Ericsson quality . . . our telephone apparatus remains at that peerless efficiency that ensures trouble-free service. ERICSSON TELEPHONES LIMITED, 56, KINGSWAY, LONDON, W.C.2. (Tel.: HOLborn 6936.)

capco

REGISTERED TRADE MARK

**QUARTZ
CUTTING
MACHINE**

**LIGHT & HEAVY DUTY MACHINES
HAVE BEEN RE-DESIGNED & IMPROVED
• • • DETAILS ARE NOW AVAILABLE**

CAPLIN ENGINEERING CO. LTD.

**1918 • • • 1943
SILVER JUBILEE YEAR**

25 years of service to the engineering and allied trades.

Well over one thousand "CAPCO" machines in use to-day, including hundreds of special machines and apparatus. "CAPCO" is synonymous with accuracy.

Designers and manufacturers of Capco Sound-on-Film recorders and equipment. Capco built recorders are in use at Elstree, Pathé News and Universal Talking News, etc. Patentees and manufacturers of Capco Enamelled Wire Cleaning machines,

BEACONSFIELD RD WILLESDEN, LONDON, N.W.10

Sole Agents : CAPCO (Sales) LTD.

Telephone : WILlesden 0067-8

STANDARD WITH THE BRITISH POST OFFICE

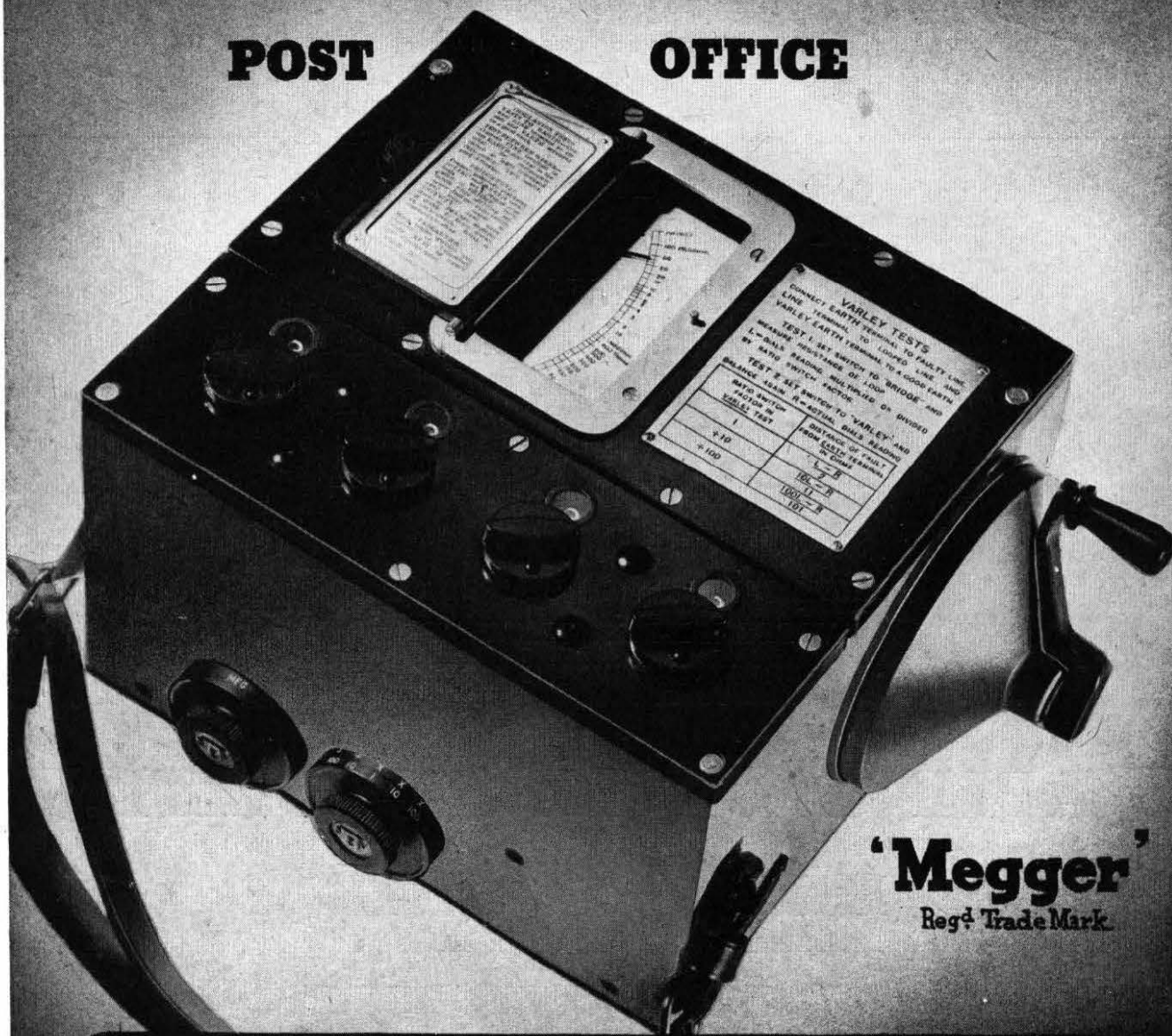

'Megger'
Reg^d Trade Mark

THE BRIDGE-MEG TESTING SET used by the British Post Office is a portable, self-contained instrument combining the functions of an Insulation Tester and a Wheatstone Bridge; it can be used for fault location by the Varley Loop method. Facilities can also be provided whereby, with the use of an external galvanometer and resistance box, the instrument may be used for making Murray Loop tests. Insulation range 100 megohms at 500 volts. Bridge range 0.01 to 999,900 ohms. Size 7 x 8 $\frac{3}{4}$ x 12 ins. Weight 12 $\frac{3}{4}$ lbs. Mains operated instruments are also supplied to the British Post Office. Ask for list X 267.

EVERSHED & VIGNOLES LTD., CHISWICK, LONDON, W.4
TELEPHONE: CHISWICK 1370 * TELEGRAMS: "MEGGER" CHISK, LONDON

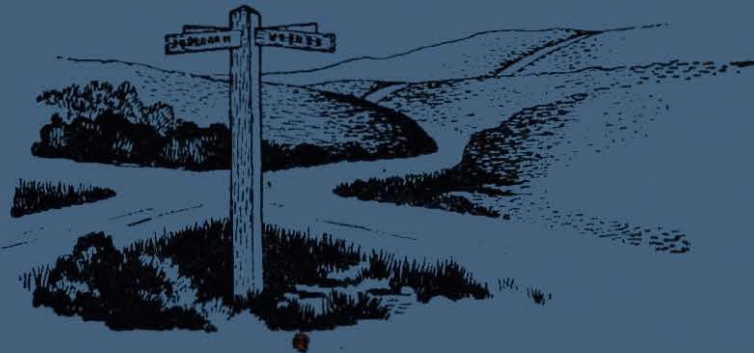

“**T**he roads of the present
lie deep in the past”

FOR every purpose demanding a dependable high standard of performance, Alton stationary batteries are installed. Behind them is a tradition of craftsmanship in battery design and manufacture and of efficient and reliable performance in service.

The established traditions associated with the name of Alton define the standard of the future and point to the choice of Alton batteries for services of vital importance.

ALTON

BATTERIES OF MERIT

THE ALTON BATTERY COMPANY LIMITED
(Sole Suppliers of FULLER Stationary Batteries)
ALTON, HANTS

Telephone: Alton 2267 and 2268
Telegrams: 'Battery, Alton'



MAINTAINING EFFICIENCY

THE HIGH STANDARD OF EFFICIENCY
OF PIRELLI - GENERAL TELEPHONE
CABLES IS MAINTAINED BY THE
CONTINUOUS RESEARCH WORK OF
AN EXPERIENCED TECHNICAL STAFF.

TELEPHONE
SOUTHAMPTON
2141 (5 lines).

PIRELLI-GENERAL
CABLE WORKS, Ltd., SOUTHAMPTON.

TELEGRAMS
"PIREKAYBEL"
SOUTHAMPTON



The finest cored Solder in the world which is speeding up and increasing the efficiency of the War Effort. Firms engaged upon Government Contracts are invited to write for free samples

MULTICORE SOLDERS LIMITED, BUSH HOUSE, W.C.2. 'Phone Temp. Bar 5583/4