

THE POST OFFICE ELECTRICAL ENGINEERS' JOURNAL

VOL. 33

APRIL, 1940

PART 1

CONTENTS

	PAGE
LONDON TRUNK EXCHANGE—INTRODUCTION OF 2 V.F. AND SEVEN-DIGIT AUTOMATIC WORKING—M. G. Holmes, B.Sc.(Eng.), A.M.I.E.E.	1
CURRENT POWER PLANT PRACTICE IN AUTOMATIC TELEPHONE EXCHANGES—F. R. Davey	12
REPLACEMENT OF THE MAIN AERIAL SYSTEM AT RUGBY RADIO STATION—F. Hollinghurst, B.Sc.(Eng.), A.M.I.E.E., and H. F. Mann	22
CONTROL OF WIRELESS TRANSMITTERS AND OTHER ELECTRICAL APPARATUS UNDER THE DEFENCE REGULATIONS, 1939—E. F. H. Gould, B.Sc., A.M.I.E.E. . .	28
STORM DAMAGE, JANUARY, 1940	33
A NEW SUBSCRIBERS' INTERCOMMUNICATING TABLE TELEPHONE SET—L. W. Ellen and S. C. Gordon	39
NOTES AND COMMENTS	43
LOCAL CENTRE NOTES	44
REGIONAL NOTES	44
STAFF CHANGES	50
BOOK REVIEWS	48, 49, 52

Price 1/- net

THE INSTITUTION OF POST OFFICE ELECTRICAL ENGINEERS

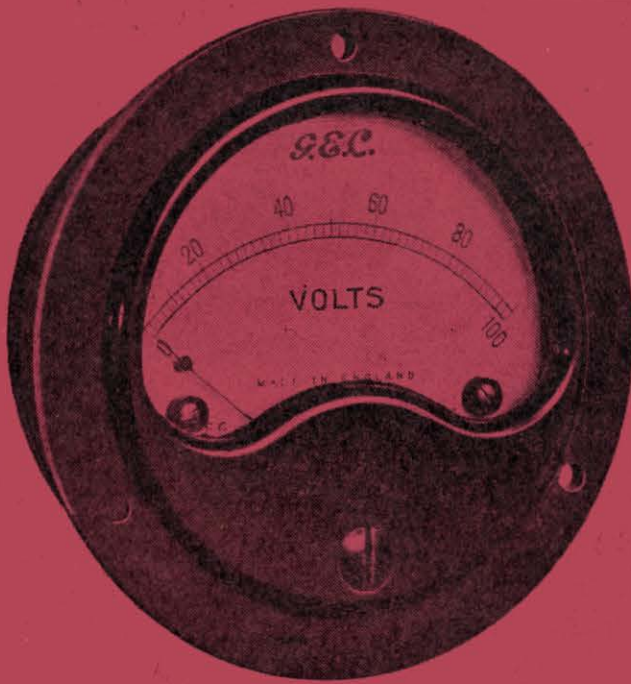

G.E.C.

ACCURATE MEASUREMENT

Accurate measurement, the essential of progress, necessitates the use of good instruments, and nowhere is this more important than in radio.

Good instruments can be designed and produced consistently only as the result of great experience in experiment and research extending over many years.

Salford Electrical Instruments Ltd. have been making first quality instruments for half a century, and their products are to be seen in constant use in Power Houses, Test Rooms and Laboratories all over the world.

Instruments in sizes from 2" upwards are available for almost every electrical measurement. The 2½" flush or projecting types are specially suited for radio purposes, and may be supplied as:—Milliammeters, Microammeters, Ammeters, and Voltmeters, D.C. and A.C.

Portable types are also made in most of these ranges. For H.F. measurements a range of Valve Voltmeters is available.

Please write for descriptive list S.27, and state particular instruments in which you are interested.



SALFORD ELECTRICAL INSTRUMENTS LTD.
PEEL WORKS, SALFORD, 3.

Telephones: BLackfriars 8888 (3 lines) Telegrams and Cables: "SPARKLESS, MANCHESTER"

PROPRIETORS: THE GENERAL ELECTRIC CO., LTD., OF ENGLAND



IN CITY

OR SETTLEMENT



Telephone service stands in the foreground.

It is a necessity to the efficient conduct of business and an asset to social life, whether the background to conversations be the roar of a bustling metropolis or the rustle of palm fronds heard through a wide-open tropic window.

Strowger automatic telephony is justly claimed to-day as the World's Standard.

It is in use in London—greatest city of the greatest Empire in the world—and it has penetrated to remote places in far-off lands. There are two reasons for the pre-



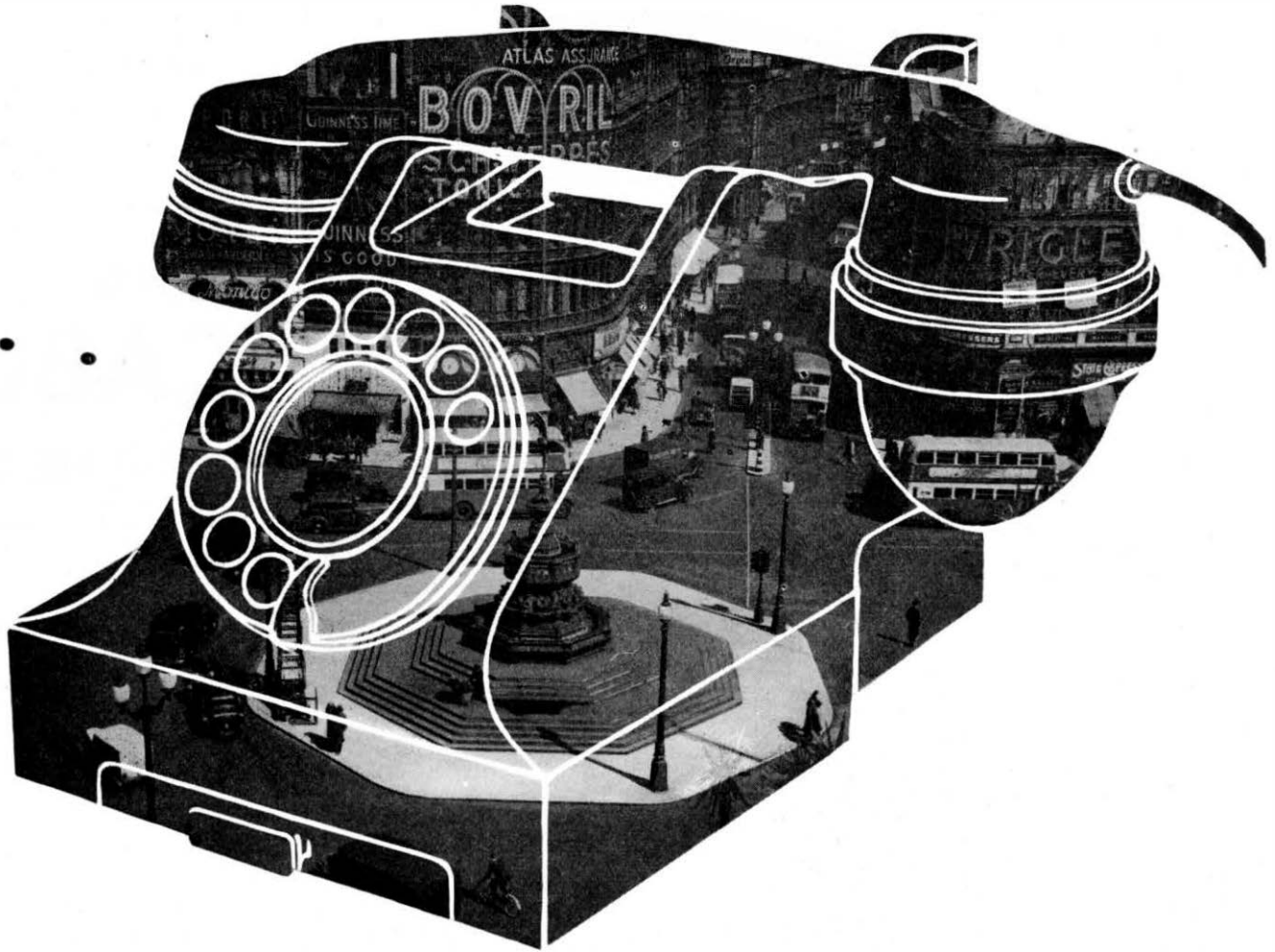

eminence of Strowger. The first is the intensive thought unceasingly applied to its development so that the highest possible standard of service can always be provided. The second is the skill and care employed in the manufacture of every component part so that unvarying efficiency and unfailing reliability are always present under the most exacting operating conditions.

The British Post Office and many of the world's greatest Telephone Administrations have standardised Strowger for all future use, whilst many thousands of private users are enjoying its advantages in Strowger Private Automatic Exchanges.

THE STROWGER DIAL ROTATES WITH THE WORLD



AUTOMATIC TELEPHONE & ELECTRIC CO. LTD.

NORFOLK HOUSE, NORFOLK ST., STRAND, W.C.2

Phone Temple Bar 9262 Grams Autelco. Estrand London

STROWGER WORKS, LIVERPOOL, 7

Phone Stoneycroft 4830 Grams Strowger. Liverpool



SIEMENS

CONTRACTORS FOR THE
MANUFACTURE AND LAYING OF
TELEPHONE CABLES

AERIAL • UNDERGROUND • SUBMARINE WITH CONTINUOUS
OR COIL LOADING
LOADING COILS



LAYING SUBMARINE TELEPHONE

SIEMENS BROTHERS

WOOLWICH, LONDON

Telephone : Woolwich



US
NG



THE CABLE ACROSS AN ESTUARY

RS & CO. LIMITED

LONDON, S.E.18

WOOLWICH 2020

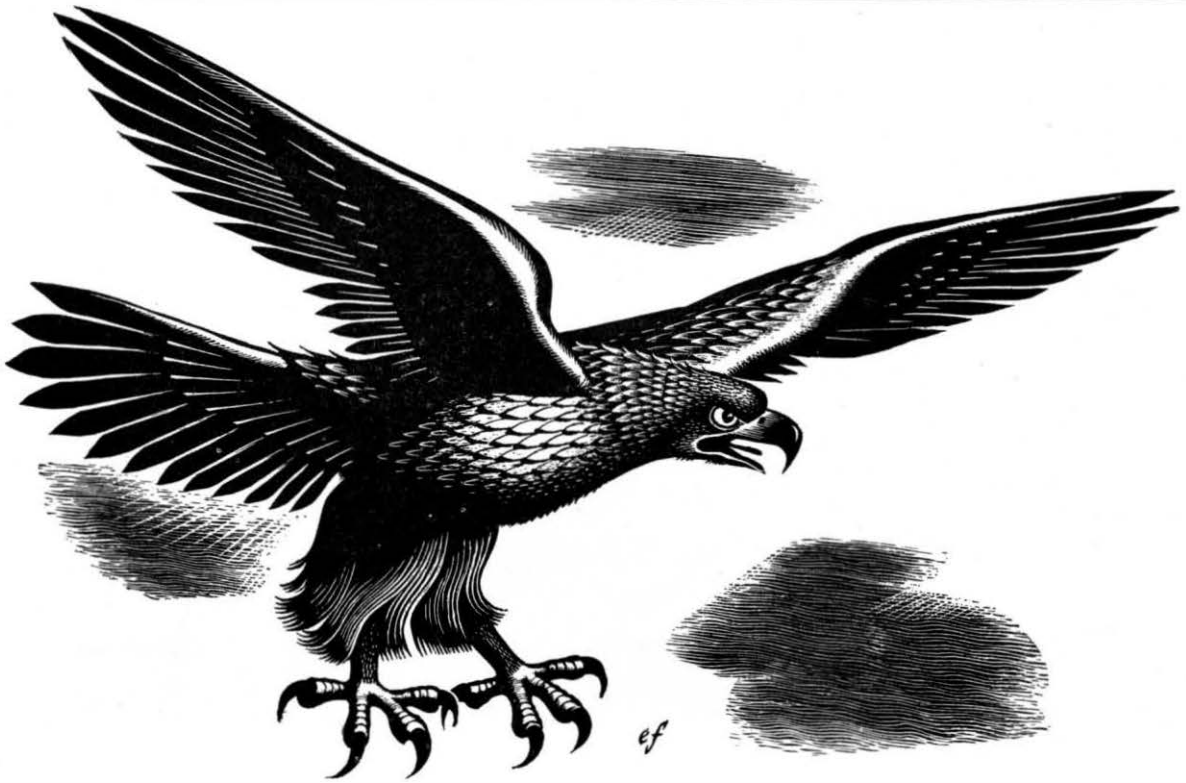

***'You cannot fly like an eagle with
the wings of a wren'***

W. H. Hudson

And a business cannot be built up to the stage the Alton Company has reached unless the quality of its products and the integrity of its policy are as high as its ambitions. Probably the development of the Alton Company could have been even faster—but only at a price not worth paying. The Com-

pany has never deviated from its policy of employing the most expert workmen and the finest materials; it has always quoted prices consistent with the highest possible quality, and it has won client after client purely by the excellence of its products and the reasonableness of their cost.

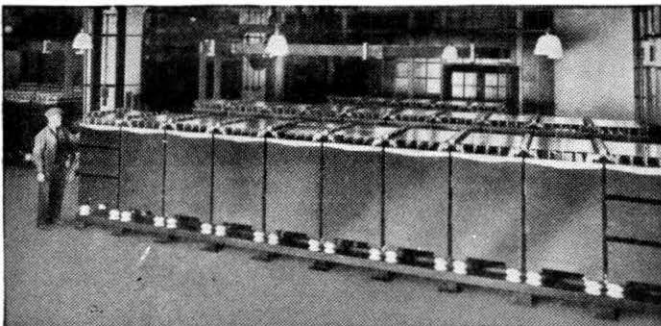

Two batteries of Alton Cells at Blackfriars Telephone Exchange, Manchester.

ALTON

Batteries of Merit

THE ALTON BATTERY COMPANY LTD

(Incorporating Fuller Accumulator Co. (1926) Ltd.)

ALTON, HANTS

Telephone: Alton 2267 and 2268

Telegrams: 'Battery, Alton'

DO NOT CONCENTRATE ON WAR

Do not concentrate your thoughts upon war subjects. You will find it very worrying and very bad for the nerves.

Read, write, sketch, paint, study your vocation : anything that will occupy your mind and your time. Make use of the long dark nights by concentrating upon something useful.

During the last war many people learned how to write short stories, etc., to-day a number of them are world-famed authors.

By becoming efficient in your vocation you can give the best service to your country and to yourself. The more you increase your earning power the better it is for the country and for yourself personally.

War or no war, earning power always brings its possessor to the front. It is no use waiting for better times. The ideal opportunity never arrives. We have to make the best of existing conditions. Therefore, delay is useless ; it is worse, it is harmful.

YOU CANNOT MAKE MONEY BY SAVING

If you save 10s. per week for 10 years you have only got £260, but if you spend 2s. 6d. per week for 12 or 18 months on a correspondence course, you give your brains a chance to earn thousands of pounds, then there is no need to save. Savings are likely to vanish, but earning capacity is a permanent investment.

DO ANY OF THESE SUBJECTS INTEREST YOU ?



Accountancy Examinations
Advertising and Sales Management
Agriculture
A.M.I. Fire E. Examinations
Applied Mechanics
Army Certificates
Auctioneers and Estate Agents
Aviation Engineering
Banking
Blue Prints
Boilers
Book-keeping, Accountancy and Modern Business Methods
B.Sc. (Eng.)
Building, Architecture and Clerk of Works
Builders' Quantities
Cambridge Senior School Certificate
Civil Engineering
Civil Service
All Commercial Subjects
Commercial Art
Concrete and Structural Engineering

Draughtsmanship. All branches
Engineering. All branches, subjects and Examinations
General Education
G.P.O. Engineering Dept.
Heating and Ventilating
Industrial Chemistry
Institute of Housing
Insurance
Journalism
Mathematics
Metallurgy
Metriculation
Mining. All subjects
Mining. Electrical Engineering
Motor Engineering
Motor Trade
Municipal and County Engineers
Naval Architecture
Novel Writing
Pattern Making
Play Writing
Police, Special Course
Preceptors, College of

Press Tool Work
Pumps and Pumping Machinery
Radio Communication
Radio Service Engineering
Road Making and Maintenance
Salesmanship, I.S.M.A.
Sanitation
School Attendance Officer
Secretarial Exams.
Sheet Metal Work
Shipbuilding
Shorthand (Pitman's)
Short Story Writing
Speaking in Public
Structural Engineering
Surveying
Teachers of Handicrafts
Telephony and Telegraphy
Television
Transport Inst. Exams.
Weights and Measures Inspector
Welding
Wireless Telegraphy and Telephony
Works Managers

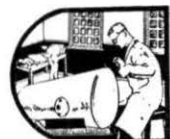

If you do not see your own requirements above, write to us on any subject. Full particulars free.

STUDY AT HOME IN YOUR SPARE TIME



CAN YOU CHANGE MY EXPRESSION ?
IF SO, YOU MAY BE THE ARTIST THAT COMMERCE IS WAITING FOR.

Just try it for yourself. Trace or draw the outline and then put in the features.

There are hundreds of openings in connection with Humorous Papers, Advertisement Drawing, Posters, Calendars, Catalogues, Trade Designs, Book Illustrations, etc.

60 per cent. of Commercial Art Work is done by "Free lance Artists" who do their work at home and sell it to the highest bidder. Many Commercial Artists draw "retaining fees" from various sources, others prefer to work full-time employment or partnership arrangement. We teach you not only how to draw what is wanted, but how to make buyers want what you draw. Many of our students who originally took up Commercial Art as a hobby have since turned it into a full-time paying profession with studio and staff of assistant artists; there is no limit to the possibilities. Let us send full particulars for a FREE TRIAL and details of our course for your inspection. You will be under no obligation whatever.

Jim Duck ART DEPT. 24

I HAVE HELPED THOUSANDS OF OTHERS . .

. . . and when I say thousands, I do not exaggerate, as I can produce well over 10,000 unsolicited testimonials from grateful students who, through our Postal Training, have achieved



their life's ambition.

If it is your desire to make progress and establish yourself in a good career, write to us for free particulars on any subject which interests you, or if your career is undecided, write and tell us of your likes and dislikes, and we will give you practical advice as to the possibilities of a vocation and how to succeed in it. You will be under no obligation whatever.

John Smith



Dept. 24, THE BENNETT COLLEGE, SHEFFIELD

EVERY DEPARTMENT IS A COMPLETE COLLEGE : EVERY STUDENT IS A CLASS TO HIMSELF

JOURNALISM

Short Story, Novel and Play Writing

There is money and pleasure in Journalism and in Story Writing. No apprenticeship, no pupillage, no examinations, no outfit necessary. Writing for newspapers, novels or pictures is not a gift; it is a science that can be acquired by diligent application and proper guidance. It is the most fascinating way of making part-time profitable. Trained ability only is required, we do the training by post. Let us tell you about it.

DEPARTMENT OF LITERATURE 24

If you attend to this now, it may make a wonderful difference to your future.

COUPON— CUT THIS OUT

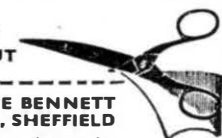

To Dept. 24, THE BENNETT COLLEGE LTD., SHEFFIELD
Please send me (free of charge)

Particulars of
Your private advice about
(Cross out line which does not apply)

PLEASE WRITE IN BLOCK LETTERS

Name

Address



COMMUNICATION EQUIPMENT

Telephones & Telephone Apparatus

Carrier & Repeater Equipment

Radio - Broadcasters & Receivers

Short - Wave Master Receivers
(for Relaying Empire Broadcasting)

Speech & Music Amplifying Systems

Power Cables Telephone Cables

Selenium Metal Rectifiers

Testing Equipment



*Technical literature on any of the above
subjects will be supplied upon request*



Standard Telephones and Cables Limited

CONNAUGHT HOUSE, ALDWYCH, LONDON, W.C.2

Telephone Holborn 8765

THE POST OFFICE ELECTRICAL ENGINEERS' JOURNAL

Vol. XXXIII

April, 1940

Part I

London Trunk Exchange—Introduction of 2 V.F. and Seven-Digit Automatic Working

U.D.C. 621.395.342

M. G. HOLMES,
B.Sc.(Eng.), A.M.I.E.E.

This article describes the work which has been carried out in the past few months in bringing into use 7-digit dialling from the London Trunk Exchange to director exchanges in the London network, followed by 2 V.F. dialling to and from zone centres in the provinces, notably Bristol and Plymouth.

Introduction.

SEVERAL articles and papers¹ have already been published on the purely technical aspect of 2 V.F. working, both on manually operated trunk circuits and on similar circuits over which zone centre operators can dial into the automatic network associated with another zone centre. This article is intended to convey an impression of the main features of the automatic equipment which has been installed in the London Trunk exchange, together with the large amount of complicated work in the change-over to automatic working of certain trunk circuits and the outgoing junctions connected to London director automatic exchanges.

GENERAL METHOD OF WORKING

Zone Centres.

As far as dialling from the London Trunk exchange to provincial zone centres is concerned, outgoing and bothway trunk circuits appear in the outgoing multiple of the sleeve control demand positions in Faraday Building to which London subscribers are connected, by dialling the code TRU from an automatic exchange or over signal junctions from a manual exchange. The trunk circuits have associated with them (Fig. 1) the appropriate outgoing sleeve control relay set, or on bothway circuits, the outgoing and incoming relay sets, together with a 2 V.F. receiver by which all operations concerned with signalling and dialling are converted into the appropriate voice frequency signal, which at the distant end operates a 2 V.F. receiver connected to the necessary relay set and automatic switching equipment.

It is not proposed to elaborate on the method of transmission of V.F. impulses and their conversion to supervisory and dialling signals, but Fig. 2 gives an outline of the main operations and signals given on calls dialled over a trunk line between two zone centres, utilising the two signalling frequencies of 750 and 600 c/s, known as X and Y respectively.

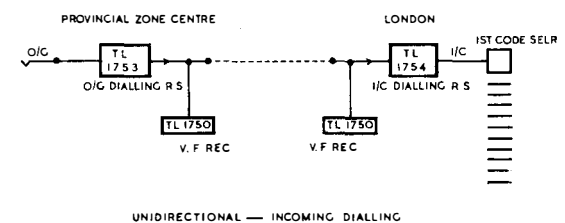
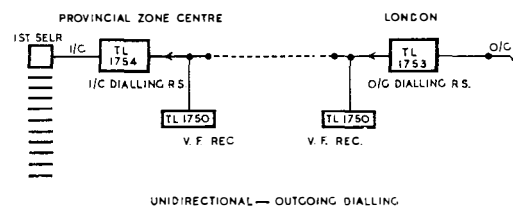
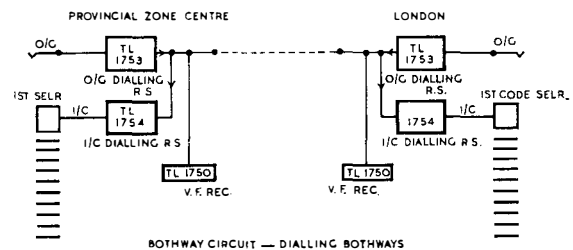

FIG. 1.—METHOD OF WORKING.

Each zone centre trunk circuit incoming to London, or the incoming side of a bothway circuit, is similarly associated with a 2 V.F. receiver and incoming dialling relay set, and thence connected to a trunk first code selector (see Fig. 1), which is the first switch in the train of connections to the objective automatic exchange in the London 12½-mile circle, embracing the director area. Access to the junctions to the automatic exchanges in the director area is obtained via first, second and third code switches, the last two types of selectors being standard group

¹P.O.E.E.J., Vol. 29, page 41.

I.P.O.E.E., Printed Paper No. 162.

O/G END		SIGNALS		I/C END	
OPERATION	SIGNAL	SENT ALONG LINE	CONDITION	OPERATION	
OPERATOR PLUGS INTO MULTIPLE OR CIRCUIT SEIZED FROM SELECTOR BANKS.	SUPERVISORY LAMP FLICKERS.	X 100	RELAY SET PREPARED FOR IMPULSING AND SWITCH SEIZED.		
DIAL KEY THROWN.	FLICKER SIGNAL CEASES		A DIALLING SIGNAL -AMP OF TONE - IS SENT BACK ONLY FROM DIRECTOR AREAS.		
OPERATOR DIALS		X X 66 33 66	SWITCH STEPS.		
OPERATOR RESTORES DIALLING KEY	SUPERVISORY TONES HEARD.		WHEN FINAL DIGIT HAS BEEN DIALLED, RINGING, N.U. OR BUSY TONE (WITH-OUT FLASH) IS TRANSMITTED. RINGING & N.U. TONES ARE INTERRUPTED FOR 1 SEC EVERY 5 SEC.		
	SUPERVISORY LAMP GLOWS.				CALLED SUB. ANSWERS.
	SUPERVISORY LAMP DIMS.				
	SUPERVISORY LAMP GLOWS.				SUB. CLEARS
OPERATOR CLEARS OR CIRCUIT RELEASED BY SELECTORS.		X X 300 33 SECS IF CALLED SUB HAS NOT ANSWERED, 1.5 SECS IF CALLED SUB HAS ANSD.	CIRCUIT CLEARS.		

NOTE.—THE ARROWS REPRESENT THE DIRECTIONS OF THE SIGNALS.
 - LETTERS - " FREQUENCIES - " " IN MILLISECONDS.
 - FIGURES - " DURATIONS - " " " "

FIG. 2.—MAIN OPERATIONS AND CORRESPONDING V.F. SIGNALS.

selectors, whereas the first code selector is of special design for trunk and 2 V.F. working.

The first code selectors have access, as in the standard director system, to A digit selectors and directors which translate the three code digits of a subscriber's number to route the call via the first, second and third code selectors to the appropriate junction group. In effect the automatic equipment, with the exception of the first code selectors, is equivalent to the code portion of a standard director exchange, except that routing to objective automatic exchanges is carried out entirely over direct junction groups with no tandem or sub-tandem routing. Zone centre operators obtain manual exchanges in the director area by dialling "O," thereby obtaining a London operator who completes the call over direct junctions in the outgoing junction multiple.

Group Centres.

At the present stage it is not proposed that provincial group centres, of which there are a large number having direct circuits to London Trunk exchange, shall be equipped with 2 V.F. apparatus, and calls in both directions will continue to be handled by the existing manual methods, as far as the trunk lines are concerned. Before the introduction of automatic working in the London Trunk exchange, every exchange, both manual and automatic, in the London Director Area, had direct junctions appearing in the outgoing junction multiple, trunk operators obtaining automatic subscribers by dialling the four digit numbers over the junction. This junction network is comprised of high-grade junctions suitable for trunk calls and is entirely separate from the local junction routes. With the growth of incoming traffic the outgoing junction multiple was rapidly becoming exhausted, resulting in increasing difficulty due to re-arrangements

necessary to accommodate new groups and extra junctions on existing groups. Owing to the large size of the multiple there was also general difficulty in completing incoming calls as expeditiously as was desirable. It was therefore decided that incoming calls to London automatic exchanges from provincial group centres, and zone centres not yet converted to 2 V.F. working, should be completed from the multiple by dialling seven digits over a common group of manual first code selectors having access to the junctions appearing on the banks of the second and third code selectors. The only exception was that four digit junction groups should be retained in part for certain large exchanges in the City and West End which receive a very large proportion of the incoming traffic, at least during the day busy hour. As a result a considerable reduction in working multiple space has been effected and will be maintained as further manual exchanges are converted to automatic working.

EQUIPMENT, DESIGN AND LAY-OUT

Main Equipment.

Fig. 3 shows the trunking scheme for the director equipment which has been installed by Messrs. Standard Telephones & Cables, Ltd., on various floors of Faraday Building, North. It will be noted that all code selectors are of the 200 outlet type. Level 1 of the first code selectors is reserved for assistance traffic and this level will mainly be used for through calls, that is, calls to other trunk centres and to exchanges obtained via the London Toll A exchange, in addition to calls necessitating special enquiries or assistance from a London operator for their completion, e.g., calls to London manual exchanges. Levels 21, 31, 41, 51, 61, 71, 81, 91, and 01 are trunked out to third code selectors which give access to groups of junctions to automatic exchanges, in addition to those from 2nd code levels. Eighty-one 2-digit translations and ninety-three 3-digit translations exist for working exchanges, and other levels are reserved for new exchanges as and when they are brought into service.

Fig. 3 also shows the cabling of the main items of equipment including code selectors, A digit selectors, directors, 2 V.F. relay sets, incoming, outgoing and bothway relay sets for trunk lines, and indicates how these items of equipment are cabled to and from the main frame and I.D.F.'s on the ground and second floors of Faraday Building, North.

It should be noted that arrangements are in hand to take all outgoing automatic junctions through standard test jacks for testing purposes, and to provide an outgoing junction routiner with access equipment covering a total of 1,400 junctions, which is roughly double the number of junctions existing before the change-over to automatic working, although this total will not be achieved for some considerable time. Fig. 4 shows one of the trunk test positions with the new test jacks. The change-over to automatic switching methods has, of course, resulted in an increase of junctions to automatic exchanges. The bringing into use of these junctions will be dealt with at a later stage.

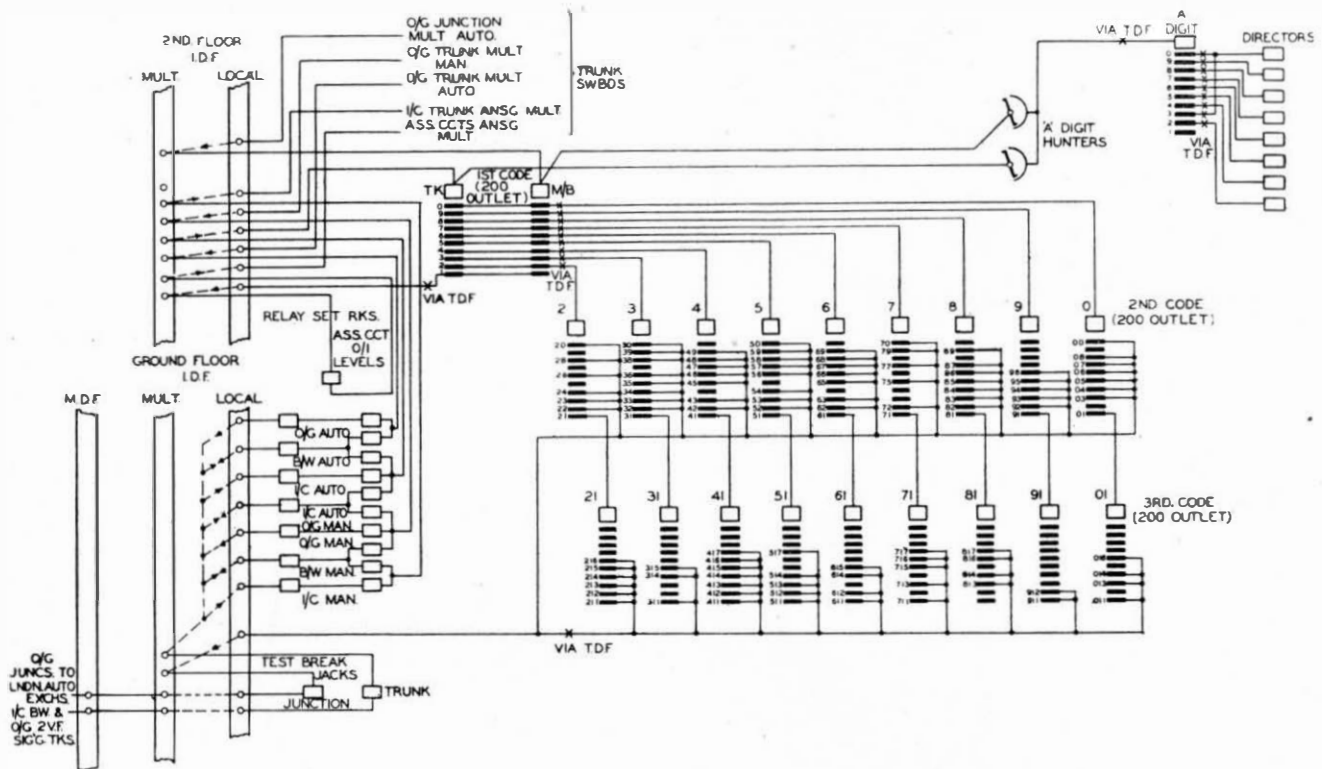

FIG. 3.—TRUNKING DIAGRAM.

As far as line relay set provision is concerned this has been limited to outgoing and incoming dialling relay sets (diagrams TL.1753 and 1754). Racks and wiring have, however, been provided to accommodate, at a later stage when it is decided to work group centres on a V.F. dialling basis, outgoing and incoming manual relay sets (TL. 1751 and 1752) to cater for circuits to and from certain automatic group centre exchanges which, owing to the nature of the equipment concerned, cannot be worked on a 2 V.F. dialling basis in one or other direction. These exchanges are Southampton, Hull, Dundee and Burton-on-Trent. Southampton will be worked entirely on a manual basis for incoming, outgoing and bothway circuits unless the Southampton system, which is Siemens' No. 5 inverse ratio impulsing, is changed before 2 V.F. working is introduced at this group centre. Hull, which is a local corporation system, will be worked dialling-in as far as incoming and the incoming side of bothway circuits is concerned, and manual 2 V.F. for outgoing and the outgoing side of bothway circuits. Burton-on-Trent and Dundee circuits are at present completely bothway and will be worked 2 V.F. dialling incoming and manual outgoing unless the systems are changed before the introduction of 2 V.F. working at group centres. Figs. 5-8 are photographs of certain of the more important equipment items.

Owing to general accommodation difficulties in Faraday Building, North, it was not possible to lay-out the equipment in a manner absolutely ideal

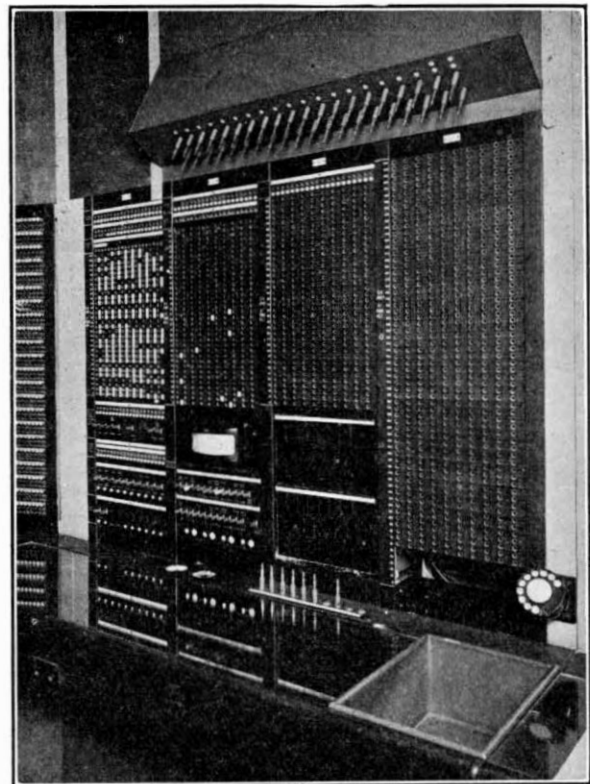

FIG. 4.—TRUNK TEST POSITION WITH NEW TEST JACKS.

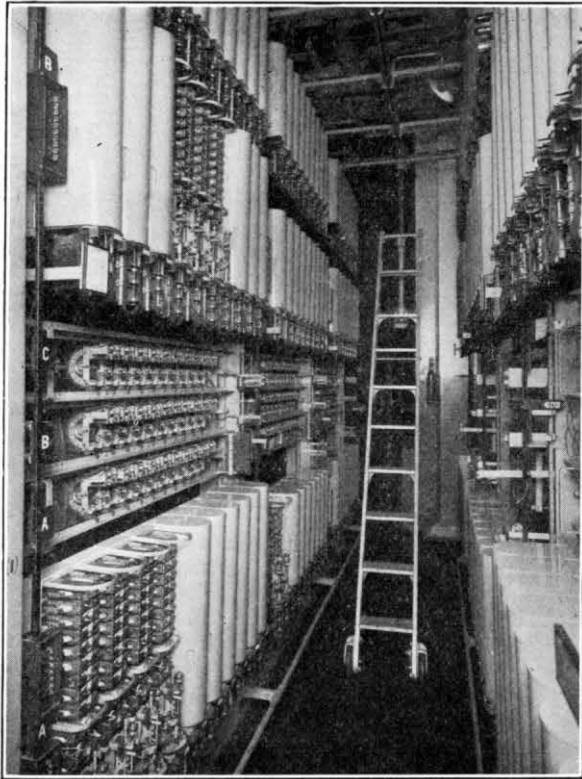

FIG. 5.—TRUNK 1ST CODE SELECTORS.

for maintenance conditions, but every endeavour was made to avoid splitting equipment of the same type over different floors. Table I shows the apparatus, number of racks, equipment and wiring for each item, with the floor on which they are situated.

TABLE I

Items of Equipment	Floor	No. of Racks	Equipment	Wiring
O/G Auto-Relay Sets and 2 V.F. Receivers ..	Gd.	18	360	520
B/W Auto-Relay Sets and 2 V.F. Receivers ..	Gd.	28	410	960
O/G Manual-Relay Sets and 2 V.F. Receivers ..	Gd.	1	—	20
I/C Manual-Relay Sets and 2 V.F. Receivers ..	Gd.	2	—	50
2nd Code Selectors ..	Gd.	36	1,836	2,160
3rd Code Selectors ..	Gd.	9	297	360
B/W - O/G Manual I/C Auto-Relay Sets and 2 V.F. Receivers ..	1st	2	—	30
B/W - O/G Manual I/C Manual-Relay Sets and 2 V.F. Receivers ..	1st	2	—	30
A digit Selectors ..	2nd	3	121	180
Directors ..	2nd	21	154	210
Assistance Relay Sets ..	2nd	10	783	900
Trunk 1st Code Selectors—Ordinary ..	3rd	54	1,455	1,620
Trunk 1st Code Selectors—Manual Board ..	3rd	16	480	480
I/C Auto-Relay Sets and 2 V.F. Receivers ..	3rd	15	360	625

Miscellaneous Equipment.

In addition to normal switching equipment one control rack and five access racks have been provided for traffic recorder purposes. Special facilities for testing 2 V.F. receivers also had to be afforded and two testers, one on the ground and one on the second floor, have been provided. Among other items of plant provided to facilitate efficient maintenance of the equipment is a special faults telephone system appearing on telephones on the ground and third floors, with joint access from the manual board, divisional supervisors' desks and trunk test racks, the test racks having 2 V.F. supply connected to them for testing on trunk lines. Circuits to the Holborn Central Fault P.A.X. are also provided, one line terminating on telephones fitted on the second and third floors. A separate bothway circuit is provided on the ground floor, the X line terminating on the test racks and the Y line on a telephone by the ground floor equipment. Telephones with exchange line facilities on Central and City automatic exchanges are also fitted in various positions for use in tracing faults on calls to the London network.

Manual testers have been provided for the 2 V.F. first code selectors, but a routiner is being designed for this equipment and, it is hoped, will be installed in the near future. Standard routiners have been supplied for A digit selectors, directors and group selectors. Additional busy keys and break-jacks were provided on the test racks on the ground floor for the additional junctions provided under automatic switching conditions.

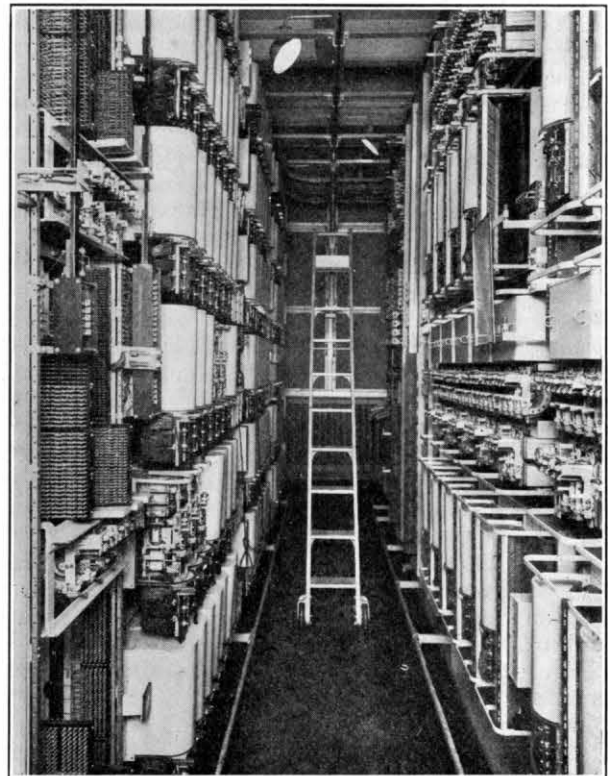

FIG. 6.—A DIGIT SELECTORS AND DIRECTORS.

Observation equipment is being supplied and will ultimately comprise three trunk demand positions with one cord circuit each, modified for observation on outgoing traffic, and four incoming positions similarly modified for incoming traffic. The observation facilities afforded are as follows :—

- (a) Repetition of supervisory signals given on the controlling position cord circuit by the cord circuit supervisory on the observation position.
- (b) A switching key to permit the use of a position for normal operating or observation work as required.
- (c) A low loss tapping circuit incorporating two amplifiers (No. 19).

To provide observation facilities at the introduction of 2 V.F. working, one position was modified initially and gives facilities for observation on 50 "O" level circuits and 100 outgoing circuits.

Power Plant.

One of the major problems in connection with the scheme was the arrangement to be employed for providing the power requirements for the system. A detailed study of the circuit loads and incidence of traffic for the equipment in the Faraday Building North Block at the end of the five year period revealed that an estimated load of 40,000 Ah per day at 50 V with a peak load of 6,000 A would be required. Many methods of providing for a load of such considerable magnitude were considered, including the provision of a separate power plant system for the

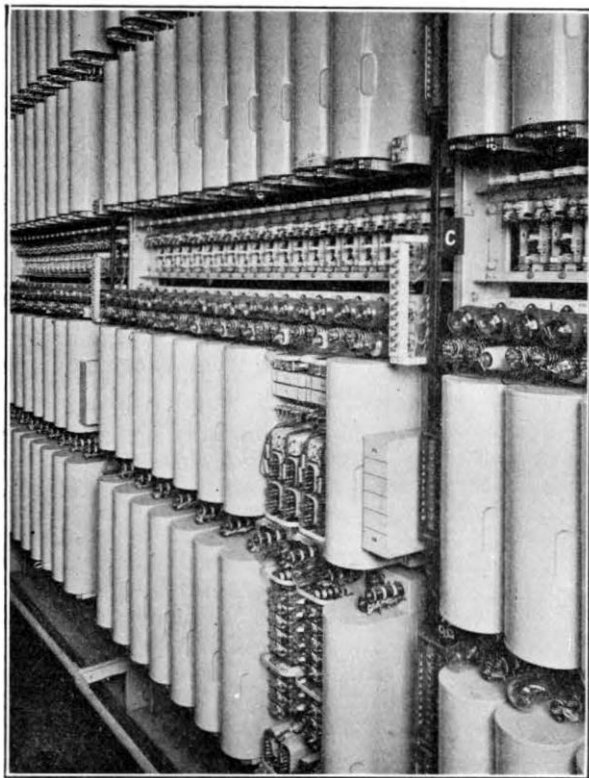

FIG. 7.—O/G AUTO RELAY SETS AND 2 V.F. RECEIVERS.

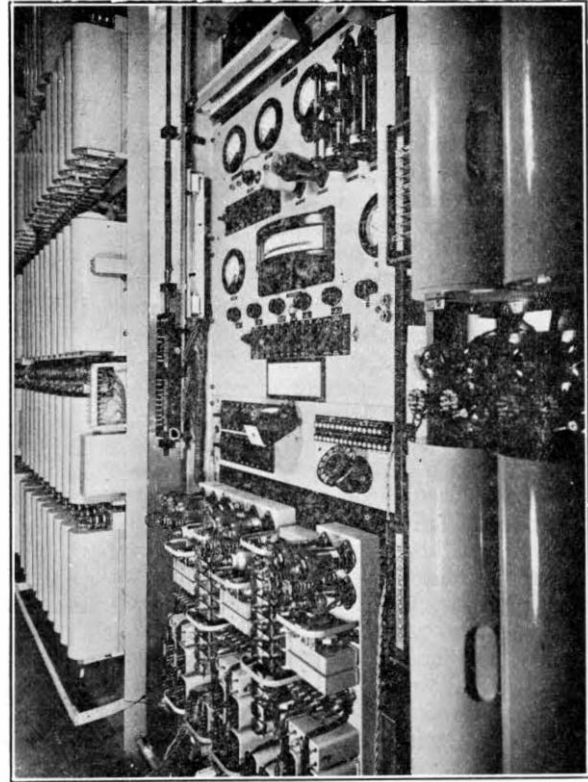

FIG. 8.—2 V.F. RELAY SET TESTER WITH B/W RELAY SETS AND 2 V.F. RECEIVERS.

2 V.F. equipment alone. It was finally decided to undertake a complete re-organisation of the 50 V power plant in the North Block involving the installation of a common plant to serve both the existing Trunk and Toll exchanges and 2 V.F. signalling equipment.

The conversion of the plant involved considerable structural alterations and extensive rearrangements in transference of other miscellaneous power plant to alternative positions. The power plant conversion has now been effected and was a remarkable engineering achievement. The work was beset by many difficulties, as is to be expected in any large job entailing the substituting of new plant for old. The object of effecting the change with as little structural alterations as possible and of retaining the maximum amount of existing plant consistent with complete modernisation were kept in mind, and much ingenuity was exercised in dismantling existing power boards and substituting new ones without interrupting the continuity of supply to the exchange.

Prior to the conversion the power plant serving the Trunk and Toll exchanges comprised two 50 V, 1,200 A, motor generators and two 50 V, 7,800 Ah batteries, the plant operating on the charge-discharge system. The new plant is operated on the divided battery float system and consists of two 50 V, 10,750 Ah batteries with four generators, two large and two small. The two large generators, driven by 400 V, 3-phase, 50 cycle, wound rotor induction motors, have a rated output of 50 V, 2,200 A, and the small generators each have a rated output of 50 V, 1,200 A,

and are driven by auto-synchronous motors connected to the 400 V A.C. supply. This L.T. supply is obtained via transformers from duplicate 11,000 V 3-phase mains from the City of London Electric Light Co., Ltd., and the Central London Electricity Co., Ltd. The normal supply is provided by either one or both of the large generators, together with the assistance of the small generators, floating across either of the main batteries. Each generator is provided with a smoothing filter to maintain audio frequency disturbance across the floating battery within the specified limits. Each machine is also provided with a circuit-breaker to protect the generator under overload or machine failure conditions. Both large generators are fitted with auto-voltage regulators which maintain the supply within the limits of 50.5 to 51.75 V at all periods of load. Each battery is floated alternately for a period of a week, the idle battery being on continuous trickle charge during the idle week to replenish any losses sustained during the float period.

The power board has been equipped, and accommodation arranged for provision of two more 2,200 A generators at a later date to meet the ultimate requirements.

The two frequencies of 600 and 750 c/s required for the 2 V.F. equipment are provided from a standard power panel of the type used by the Post Office for four frequency key-sending equipment.

Notable points concerning the power plant are given below :—

- (1) Battery busbars and main feeders are designed to carry 6,000 A. Each feeder in the battery

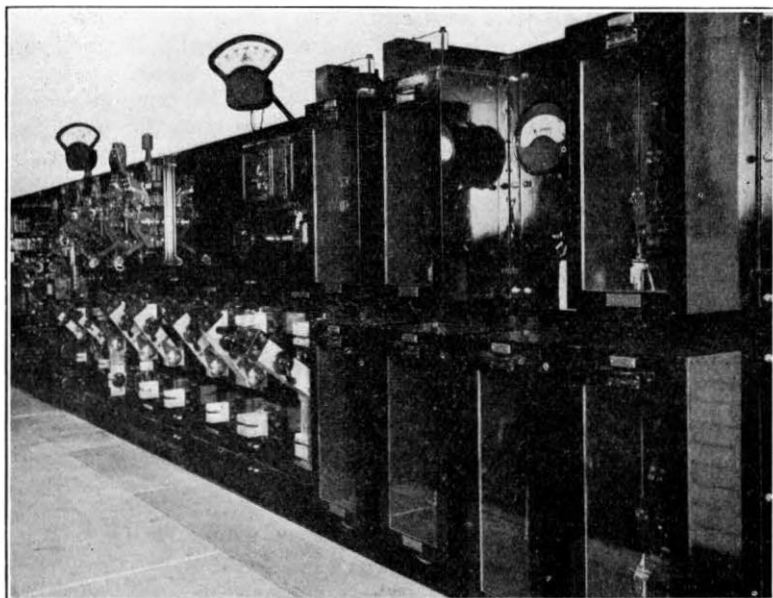

FIG. 9.—POWER BOARD.

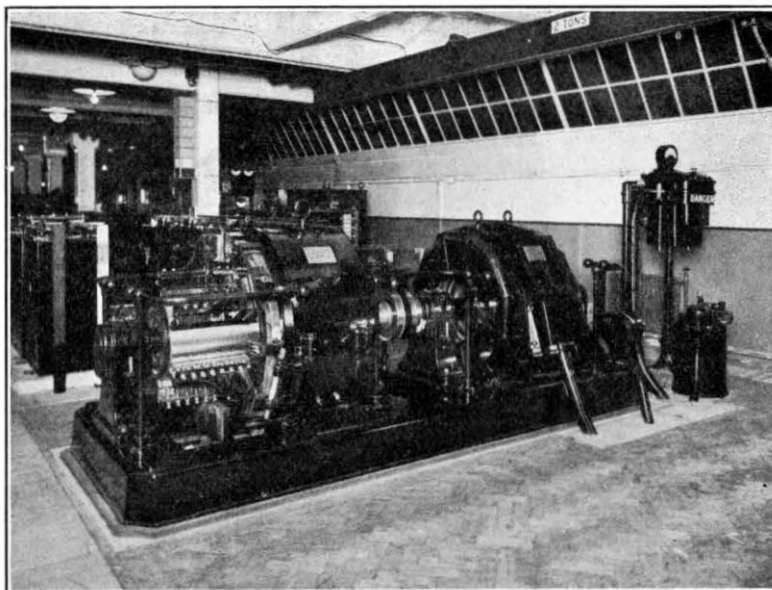

FIG. 10.—LARGE GENERATOR WITH FILTER.

room has a cross sectional area of 18 sq. in. and the total weight of the battery bus-bar work is estimated to be $5\frac{1}{2}$ tons.

- (2) Each floor of the building is served by a separate feeder from the power room, and an overload circuit-breaker is connected in each feeder. The circuit-breakers are fitted with a copper strap for the purpose of short-circuiting the breaker, when maintenance attention on the item is required.
- (3) The main discharge switch on the power board is of the knife pattern (make-before-break type) and is rated to carry 6,000 A. Owing to the weight of copper required, the change-over is usually effected by two men.
- (4) The length of the power board for 50 V equipment is approximately 19 ft.
- (5) Ringing and tones are supplied from the trunk exchange ringing machine.
- (6) Makers of large generators and smoothing filters :—
Messrs. Bruce, Peebles, Edinburgh.
- (7) Makers of small generators and smoothing filters :—
Messrs. Electric Construction Co., Wolverhampton.
- (8) Power plant installed by S.T. & C., Ltd.

Figs. 9 and 10 show the power board, and one of the large generators with the smoothing filters.

INTRODUCTION OF SEVEN-DIGIT DIALLING FROM INCOMING TRUNK POSITIONS

General.

The programme of equipment provision, including the installation of director equipment, manual board first code selectors, 2 V.F. relay sets and line relay sets at London, together with 2 V.F. equipment at Bristol and Plymouth, was so arranged that the director equipment and manual first codes at London were the first to be completed. This enabled the introduction of 7-digit dialling from the London Trunk positions to be effected as a first stage before any transfer to 2 V.F. dialling incoming to or outgoing from London was carried out.

The Post Office call through test on the manual first code selectors, A digit selectors, directors, second and third code selectors was completed early in January, 1939, and, in the meantime, preparatory arrangements were being made for the change-over to automatic working of the outgoing junctions which were working on a 4-digit manual basis from the incoming trunk positions.

Owing to the various suites of positions being divided between various floors, large junction routes were segregated into two or more groups from two or more outgoing junction multiples, whereas smaller groups were common to the multiple of several floors. Under the conversion to automatic working it was, of course, necessary to increase the number of outgoing junctions owing to the change from manual to automatic selection, and, as in the majority of exchanges the whole group was transferred to automatic working, opportunity was taken to clarify the coding of outgoing junctions which had become unduly complicated owing to the large number of floors from which they were accessible.

Change-over Arrangements.

Owing to junction line plant limitations it was not possible to provide new junctions equal in number to the total new requirements, so that it became necessary to utilise the existing 4-digit junctions plus a number of new junctions to make up the automatic group. To 23 large exchanges in the City and West End a 4-digit route was retained from the second-floor suites, Main and Annexe (combined multiple), to simplify the completion of traffic from the group centres and unconverted zone centres, which is exceptionally heavy during the busy hour. In addition, to 19 of the 23 exchanges mentioned above, the separate 4-digit group from the International suite on the first floor was retained for international traffic, the greater part of which originates from or is directed to these exchanges.

As far as the junctions to the automatic exchanges were concerned, including the 23 exchanges mentioned above, it was necessary to connect the additional junctions direct to the grading from the code selectors, whereas the existing junctions had to be wired via change-over keys enabling disconnection from the manual board and connection to the grading to be effected by the simple operation of throwing the key. Fifteen automatic exchanges had to be omitted from this arrangement at the outset and retain 4-digit

dialling for some time as it was not possible, owing to temporary junction cable exhaustion, to provide the additional junctions required for automatic selection. When 2 V.F. working was introduced it was necessary for the provincial operator to dial "O" for a London operator to complete calls to these exchanges as for calls to manual exchanges.

The new junctions were connected to the end of the grading in order to retain the numbering sequence as far as possible. A diagram of the wiring of the change-over key for a junction circuit is shown in Fig. 11. In the normal position of the key the junction

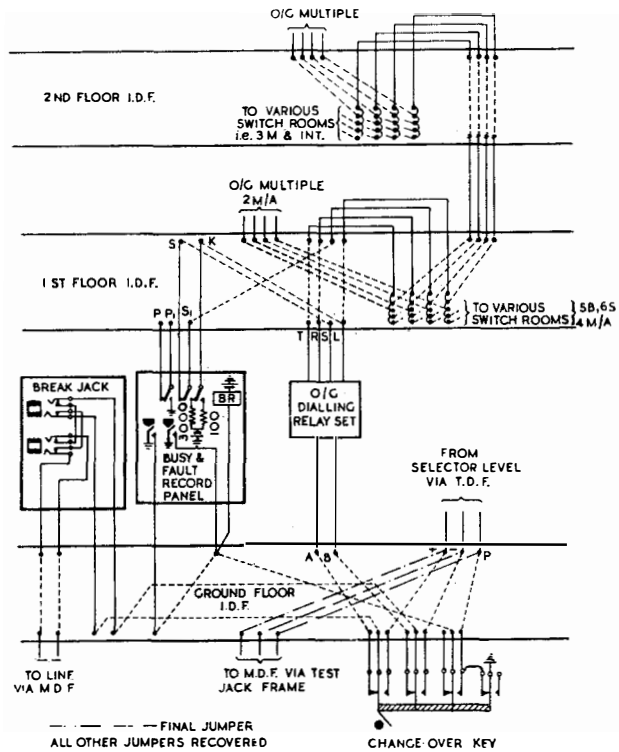

FIG. 11.—JUNCTION CHANGE-OVER ARRANGEMENTS.

line passes through the break-jacks via the key to the outgoing dialling relay set, thence to the outgoing junction multiple via the first floor I.D.F., further connection being made to the second floor I.D.F. and other multiples via tie circuits. The P wire of the selector level is busied by an earth from the key.

Under normal conditions the operation of the push button on the busy and fault record panel puts an engaged condition on the sleeve of the multiple jack and also causes the free line signal relay to operate. With the change-over key thrown the junction is connected to the selector level and the earth on the P wire is removed. The outgoing dialling relay set is disconnected and the relay on the busy and fault record panel operates, putting engaged condition on all the multiple jacks in addition to operating the free line signal relay. The final jumpering arrangement is also shown on the diagram.

It was necessary to change over approximately 650 junctions initially and the trunk circuits in various batches at a later date and it was decided to use one key per circuit for this purpose. Eight

hundred keys (No. 73) fitted on a suitable framework were installed at the end of the trunk test I.D.F. on the ground floor and were cabled to 120 strips connection (3 × 20) fitted on the last twelve verticals on the multiple side of the trunk test I.D.F. The A and B lines of circuits to be transferred were connected via the change-over keys and the P wires of the code switch outlets connected via the make springs of the keys to the junction BR relay tags on the multiple side of the I.D.F. Additional outgoing junctions were, of course, connected via the I.D.F. in the normal manner. Fig. 12 shows the keys fitted on the framework.

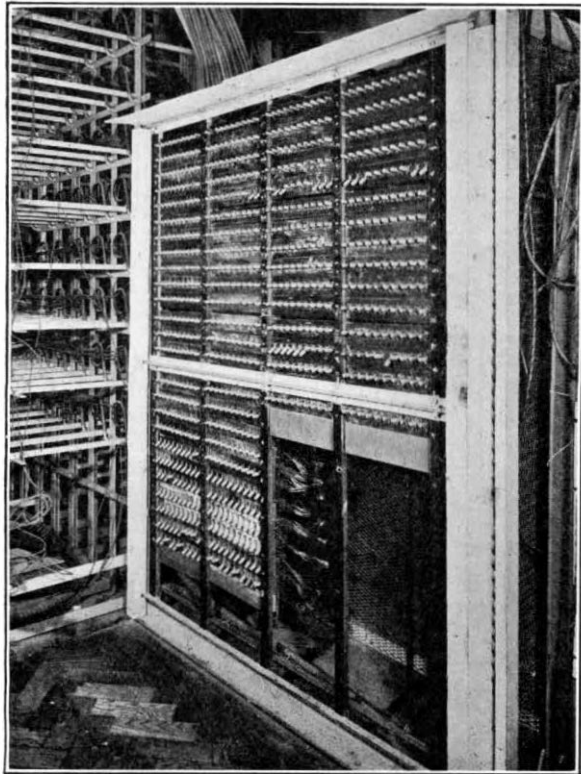

FIG. 12.—CHANGE-OVER KEYS.

At the incoming ends the additional circuits were connected direct to the first numerical selectors, whereas the existing junctions were connected via break-jacks to the local auto-manual board for trunk offering purposes. The manual connection was cut out after the transfer to automatic working was completed. No change-over arrangements were necessary at the incoming ends, with the exception of Ambassador, Central and City, for which exchanges an entirely new group of junctions was provided, but owing to the fact that the number of spare first numerals was limited, arrangements had to be made to change over the existing first numerals to the new circuits.

Engineering tests on the existing and new junctions, followed by traffic trials, occupied a period of approximately four weeks, completion being effected in the middle of February, 1939. The tests proved to be quite satisfactory, except that a high percentage, namely

10 per cent., of busy tones was recorded for certain exchanges; this was found, however, to be due to inadvertent overloading of the gradings due to an abnormal number of calls being passed to the same final selector units.

Cut-over.

The cut-over of the junctions was carried out in four groups over four succeeding week-ends, commencing on March 4th. The necessity for carrying out the transfer in four stages was occasioned by the limitation of spare multiple capacity in the outgoing junction multiple, and before the first stage of the change-over spare space was only available for about 25 per cent. of the total manual board first code selectors, namely, 480. Approximately 650 existing junctions were changed over during the four week-ends, and the total number brought into use was 1,370. The numbers in the four stages were 360, 390, 350 and 270, covering 29, 24, 17 and 18 routes respectively.

Engineering and traffic tests were carried out before the cut-over on each junction route from the manual board first code selectors, both as regards existing and new junctions, and the whole route was re-tested immediately afterwards. Following each week-end cut-over it was necessary to clear the multiple of the manual groups which had been changed over, certain re-arrangements made in regard to multiple jacks and free line signals, and additional manual board first code selectors jumped up ready for the next week-end. All these operations were carried out successfully with minimum interference with the service, and some idea of the magnitude of the work may be ascertained from the following figures:—

Miles of 4-wire jumper provided ..	=	32
Miles of 3-wire and single-wire jumper provided	=	61
Miles of 4-wire jumper recovered ..	=	27
Number of labels recovered and replaced	=	70,000
Numbers of groups of circuits on which free line signal re-arrangements were concerned	=	180

The whole of this work was necessary to provide additional director outlets from the multiples, spare jacks to facilitate the change-over to 2 V.F. signalling and new positions for the outgoing junction routes which retain a number of 4-digit circuits.

In this way the greater part of the automatic network from London Trunks was brought into use on a 7-digit dialling basis ready for the introduction of 2 V.F. dialling from provincial zone centres. Six of the automatic routes which could not be provided at the outset were cut over early in June, 1939, and the remainder in December.

Trunk Offering.

Mention should be made here of the fact that, under automatic working, the procedure for trunk offering has been somewhat modified. Under the 4-digit dialling system, if the trunk operator found the subscriber busy, she dropped the connection and

dialled the exchange to which the subscriber is connected, followed by 0109, which enabled her to connect with the trunk-offering operator at the local auto-manual board and ask the local operator to interrupt on Junction No. . . . The local operator offered the trunk call to the subscriber over the trunk-offering circuit after breaking in, via a break-jack on the auto-manual board, to the junction over which the trunk operator has dialled 0109, thus dropping the latter circuit. In the meanwhile, the trunk operator dialled over another junction the first three digits of the subscriber's number, and when she heard the local subscriber hang up upon request from the local operator and also received a clear when the local operator withdrew the plug from the break-jack, she dialled the last digit of the subscriber's number and thus completed the trunk call.

Under 7-digit dialling conditions the trunk operator obtains the 0109 circuit required and asks the local operator to interrupt for a trunk call, "junction unknown." The expression "junction unknown" is the indication that the junction on which the request is made cannot be picked up at the local exchange on a break-jack. The trunk-offering operator, having repeated the number required, inserts the associated calling cord into a TKO circuit, and obtaining connection to the required subscriber, asks him if he will accept the trunk call. The trunk operator remains in circuit during the whole of these operations. If the subscriber agrees to accept the call he hangs up and the trunk offering operator's calling supervisory lamp glows, whereupon she clears down immediately both calling and answering cords, thus giving a clear to Trunks. During the course of these operations the London trunk operator will have set up a new connection on a different junction to the required subscriber and, in the ordinary course, will have dialled the three exchange code digits, followed by the first three digits of the numerical position of the subscriber's number; the fourth digit is dialled when a clear is given to trunks via the trunk-offering operator and the connection is completed.

Service.

As is general with new methods of working, various troubles which gave rise to failures on public traffic after the cut-over had to be eradicated and a special series of test calls totalling 10,000 calls in all was carried out to ascertain the nature of these troubles. The number of failures was approximately 4 per cent. of the total calls as far as engineering plant was concerned, and this, of course, included all engineering defects in the London network.

Special efforts made both by engineering and traffic staff resulted in a general improvement in the service, and there is little doubt now that the 7-digit method of dialling into the London system is proving quite satisfactory.

CUT-OVER OF BRISTOL AND PLYMOUTH TRUNK CIRCUITS TO 2 V.F. DIALLING

General.

During the period of junction tests and traffic trials on the 7-digit equipment extended engineering

trials on 2 V.F. receivers were carried out between London and Bristol, 30 2 V.F. receivers being loaned to Bristol for this purpose. Delay in provision of 2 V.F. receivers at Bristol and Plymouth resulted in engineering tests on the permanent equipment having to be commenced later than was originally envisaged. Complete field trials of each trunk route were made and subsequently a skeleton number of receivers were made ready at Bristol for the cut-over of ten bothway circuits, 29 outgoing circuits, and three incoming circuits on the London-Bristol route. At the same time a large number of calls were passed into London over the Newcastle-London route with the object of testing the London Director equipment under 2 V.F. conditions, although the Newcastle equipment as a whole will not be ready for working until early in 1940.

Methods of Change-over.

Owing to the complicated nature of the 2 V.F. terminations as compared with the arrangements under manual conditions, it was necessary to adopt a special scheme for the change-over of circuits for engineering and traffic trials and the ultimate cut-over.

The transfer of zone trunk circuits from generator signalling to 2 V.F. auto working was carried out, using the existing change-over keys previously used for the junction change-over. To avoid an unduly complicated jumpering scheme, a set of spare multiple jacks known as "hospital" jacks were jumpered to

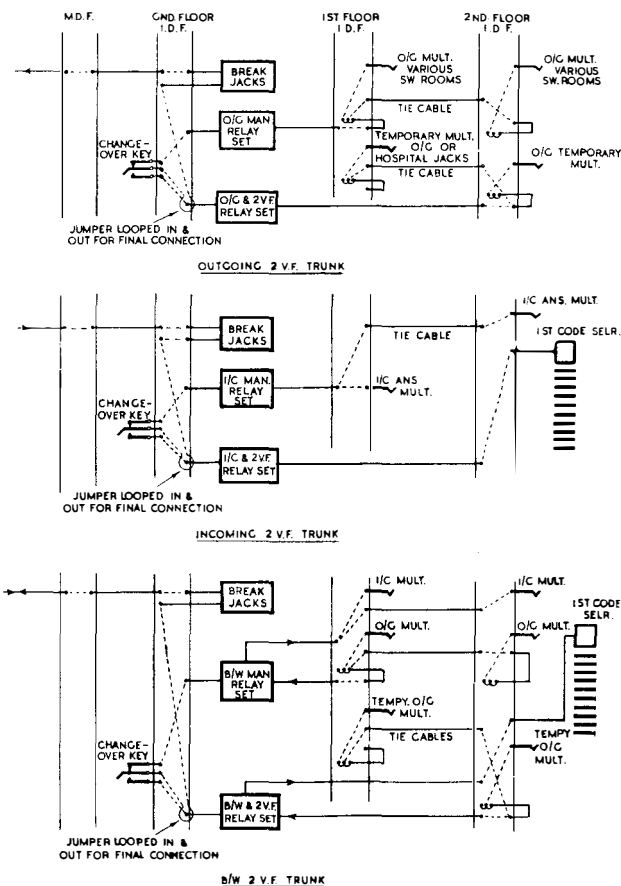

FIG. 13.—SCHEMATIC TRUNK CHANGE-OVER ARRANGEMENTS.

the 2 V.F. relay sets for the outgoing circuits and the outgoing side of the bothway circuits. A schematic of these arrangements is shown in Fig. 13.

As indicated previously, the spare jacks were obtained after the transfer to 7-digit working by re-arrangement of manual and 4-digit junction groups. The transfer of a trunk circuit from manual to 2 V.F. working was effected by throwing the appropriate change-over key. The normal multiple jacks were pegged temporarily during test periods. After the actual cut-over, followed by satisfactory tests, the circuits were restored to their normal jacks and the junction jacks thrown spare.

Fig. 14 shows the details of jumpering and key arrangements for a 2 V.F. bothway circuit. This

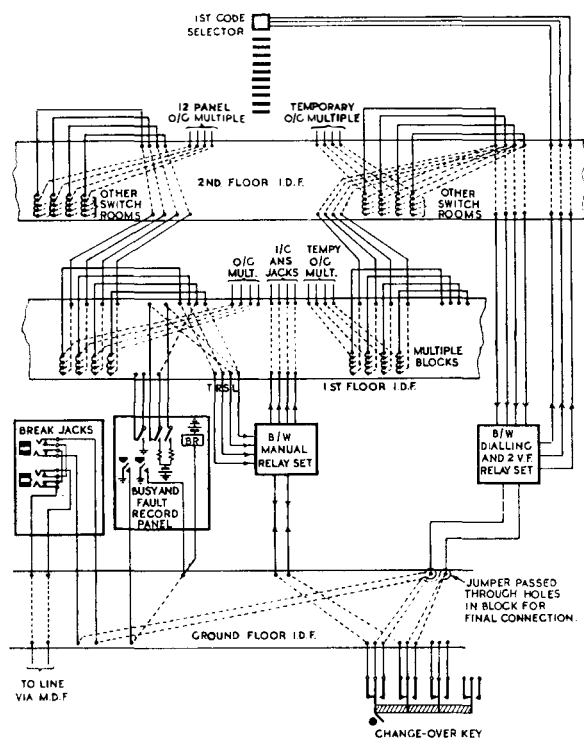

FIG. 14.—DETAILED CHANGE-OVER ARRANGEMENTS FOR B/W TRUNK CIRCUIT.

will suffice to show the general principles applied to all circuits. The line passes via the break-jacks to the moving springs of the change-over key which, in the normal position, connects to the bothway manual relay set; this relay set is connected on one side to the incoming answering equipment, and on the other side to one of the outgoing multiples via the first floor I.D.F. Connection is also made to other multiples via the second floor I.D.F.

The temporary jacks are teed to the outgoing side of the relay sets associated with the 2 V.F. relay sets and the other side of these relay sets is connected to the first code selector. When the change-over key is thrown, the whole of the manual connections are cut out. The permanent jumpering, including the jumpering of the outgoing side to the original multiple jacks, was completed after the transfer. Under normal manual conditions operation of the push button on the busy and fault record panel puts an

engaged test on the sleeve by means of the associated relay. It will be seen from the diagram that the use of the "hospital" jacks considerably facilitated the testing and cutting over of the trunk circuits.

Testing and Change-over.

Engineering tests on the London-Bristol route were completed on June 22nd and, after traffic trials, ten bothway circuits, 29 outgoing and three incoming were cut-over on June 25th. The traffic trial results gave 4 per cent. failures on 1,000 calls, but this figure was probably a little lower than would be expected under working conditions, as many of the calls were directed to definite service points and there was also a certain percentage of "O" level calls.

Various problems arose during the tests. A considerable number of "lock-ups" had occurred on the experimental manual 2 V.F. circuits between London and Bristol, and views had been expressed that similar trouble might be expected on the dialling circuits. It was found, however, that during the trials made on the dialling equipment prior to the transfer, over 10,000 calls had been passed and only a very small number of "lock-ups" had occurred. Further, all of these were due to the same cause and a simple cure was found and applied.

Another feature which required investigation was the possibility of static and harmonics causing trouble on 2 V.F. receivers when the circuits were connected to radio and carrier channels. Certain tests were carried out and very little trouble was experienced, but arrangements were made to carry out further tests, more especially when considerable atmospheric interference was present on the radio circuits.

An interesting aspect of the change-over of the Bristol circuits was that certain of the ringers at Bristol were of the G.E.C. type and therefore formed integral parts of the line termination. To remove these ringers from the circuit, which was essential for 2 V.F. working, involved a considerable amount of circuit modification. It was therefore necessary to take the circuits concerned out of service before the transfer in order to afford sufficient time for this work to be completed. The remaining circuits at Bristol and the circuits at London and Plymouth did not present this difficulty since their ringers could be removed simply by shifting "U" links.

Certain of the circuits transferred to 2 V.F. working are used as part-time private wires; for this purpose ringers are necessary and arrangements have, therefore, been made for the ringers on these circuits to be restored by simple means as and when required.

In connection with the transfer scheme, notice had also to be taken of the alterations of multiple pegging at London Trunks and the engineering and traffic aspects of the number of circuits to be transferred in stages. It was finally decided that the first part of the Bristol route should be transferred as follows:—

- (a) London released the outgoing circuits to Bristol at 9 a.m. and transferred at 2 p.m. to 2 V.F. working.
- (b) Bothway circuits were released at 2 p.m. and transferred to 2 V.F. working at 4 p.m.

This transfer on June 25th was followed on October 15th by the Plymouth route, comprising 13 outgoing circuits, 12 bothway and 11 incoming. The remainder of the Bristol route, namely, 28 circuits, was transferred on November 19th.

Future Programme.

The remaining zone centre routes to and from London, with their proposed dates of conversion as envisaged at the time of writing, are as follows :—

Manchester =Jan., 1940	Glasgow =July, 1940
Newcastle =Feb., 1940	Leicester =Aug., 1940
Birmingham =Apr., 1940	Sheffield =Nov., 1940
Belfast =May, 1940	Edinburgh =Dec., 1940
Nottingham =May, 1940	Liverpool =Jan., 1941
Leeds =June, 1940	Aberdeen =Mar., 1941

General Organisation.

A large transfer of this nature could not be effected without close co-operation between the many parties concerned with the equipment, traffic and line aspects. A committee was set up consisting of representatives

from the Telecommunications Department, Engineer-in-Chief's Office (Equipment and Telephone Branches), London Telecommunications Region Engineering and Telephone Branches (Long Distance), London Telecommunications Region City Construction Section and Long Distance Section. A considerable number of meetings was held to discuss every phase of the transfer, including testing-out, traffic trials, change-over arrangements, multiple re-arrangements, observation results, etc. Considerable credit is due to the engineering staff of the City Construction and Long Distance Sections, together with the operating staff of the London Telecommunications Region (Long Distance), by whose efforts and co-operation the work was carried out so successfully. The advice and help afforded by the various headquarters officers, engineering and traffic, were invaluable.

In conclusion, thanks are due to colleagues in the engineering branch of the London Telecommunications Region for information and diagrams connected with the change-over, and also the photographic section of the Editorial Branch of the Engineer-in-Chief's Office for the photographs.

TELEGRAPH AND TELEPHONE PLANT IN THE UNITED KINGDOM
TELEPHONES AND WIRE MILEAGES. THE PROPERTY OF, AND MAINTAINED BY, THE POST OFFICE IN EACH
REGION AND ENGINEERING DISTRICT AS AT 31st DECEMBER, 1939.

NO. OF TELEPHONES	OVERHEAD WIRE MILEAGES			REGION OR DISTRICT	UNDERGROUND WIRE MILEAGES		
	Trunks and Telegraphs	Junctions	Subscribers *		Trunks and Telegraphs †	Junctions ‡	Subscribers ¶
\$1,201,977	826	1,456	64,223	London Region	476,585	1,311,044	3,365,971
151,158	2,151	9,517	72,753	South Eastern	218,988	53,135	407,876
189,988	9,333	24,786	145,606	South Western	255,932	47,872	403,098
135,702	8,646	19,080	118,609	Eastern	342,567	65,533	291,944
155,114	8,327	17,909	114,016	North Midland	363,324	65,684	327,325
177,367	5,132	15,318	108,566	South Midland	327,624	87,410	448,390
102,035	4,654	15,723	76,238	South Wales	204,762	42,323	174,934
79,586	7,187	16,356	79,871	North Wales	225,506	22,656	137,331
145,195	2,060	5,253	36,829	Birmingham	194,428	142,891	344,891
370,111	2,709	7,964	99,284	N. Western Region	467,350	206,366	1,018,131
43,735	8,808	6,950	23,128	Northern Ireland	41,924	13,656	94,810
317,419	14,072	20,875	146,288	N. Eastern Region	517,458	152,691	778,228
294,879	24,915	31,723	146,027	Scottish Region	439,011	119,916	587,496
3,364,266	98,820	192,910	1,231,438	Totals	4,075,459	2,331,177	8,380,425
3,330,307	101,020	194,292	1,207,292	Totals as at 30th September, 1939	4,003,134	2,248,697	8,285,803

* Includes all spare wires. † All wires (including spares) in MU cables. ‡ All wires (including spares) in wholly Junction cables.
 ¶ All wires (including spares) in Subscribers' and mixed Junction and Subscribers' cables. § Quarterly review replaced by six-monthly review from September, 1939.
 || Figure amended since issue of September return.

Current Power Plant Practice in Automatic Telephone Exchanges

U.D.C. 621.311.8 : 621.395.722

F. R. DAVEY

The present standard power plant systems for automatic telephone exchanges have been established in service for approximately two years and the Author reviews the systems employed and describes some of the interesting points regarding their performance.

Introduction.

WHEN visiting a modern telephone exchange, one's primary interest is usually centred on the multifarious racks of equipment, the type of system employed and the general appearance of the automatic exchange equipment as a whole. There is, however, a portion of the exchange which may easily be passed unnoticed and yet is the nerve centre without which the exchange cannot function. Very few articles are written on the subject of power plant, and for this reason the arrangements for the supply of power to an automatic telephone exchange are often regarded as a branch of engineering separate from the general functioning of the exchange. Although this may be so to a certain extent, the specialist in one branch can and should acquire an acquaintance with the technical activities of another, and this task is considerably simplified if those who are familiar with a particular branch of engineering give an outline of their subject. It is with this view in mind that this article is written.

The operating principles of modern systems for supplying power at telephone exchanges have been previously described¹; but since that time experience of the performance of the systems has shown various modifications to be desirable.

The standard power plant systems are divided into four categories, and the system installed at any particular exchange is dependent on the 24-hour consumption at the ultimate life of the exchange. The basis on which the power plant systems are installed is given in Table I.

TABLE I.

Installation	Ultimate Consumption Ah per day	Mains Supply Available
Divided Battery Float System	2,000-10,000	A.C. or D.C.
Parallel Battery Automatic System	200- 2,000	A.C. or D.C.
Single Battery Automatic System	Up to 200	A.C.
Double Battery Charge-Discharge System	Up to 200	D.C. or no supply

DIVIDED BATTERY FLOAT SYSTEM

This system is usually employed at the larger type exchanges, e.g., director exchanges having upwards of approximately 5,000 D.E.L.'s. The number of lines is typical only, owing to the fact that the power consumption has no direct relation to the number of lines, but is largely dependent on the calling rate and incidence of traffic individual to the exchange concerned.

In considering the fundamental principles of the system, an elementary description of the floating conditions may be of interest. A simple explanatory circuit of the scheme is shown in Fig. 1.

¹ I.P.O.E.E., Paper No. 156.

The power supply to the exchange is served direct from a continuously running D.C. generator in series with a filter unit, a floating battery being placed in parallel with the exchange. The filter unit is designed to be capable of suppressing any audio frequency disturbance of sufficient magnitude to interfere with the commercial use of the exchange. By use of an automatic voltage regulator, the voltage across the battery is maintained between the limits of 50.5

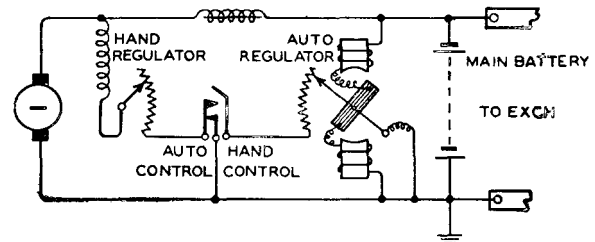

FIG. 1.—SIMPLE FORM OF FLOAT SCHEME.

and 51.75 volts regardless of the normal working exchange loads. Under these conditions the battery may be regarded as idle, receiving no charge nor yielding any discharge. Actually the conditions are analogous to the power attendant continuously adjusting the generator field regulator to maintain constant voltage under load changes on the exchange. The primary function of the battery is to provide an automatic stand-by in the event of a mains supply failure, or breakdown of the generator. If 100 per cent. continuity of supply were obtainable from the generator, the battery could be dispensed with and the exchange be served direct from the generator alone.

Originally this scheme was designed on the basis of the battery having a capacity to meet the exchange requirements for the twelve busiest hours of the day which is found generally to represent approximately 90 per cent. of the 24-hour load. It has recently been decided, however, to increase the battery capacity to provide a 24-hour reserve, and all new installations are being provided on this basis. During the floating or idle condition a gradual deterioration of the battery capacity occurs owing to self-discharge by local action and slight occasional momentary discharges. In practice this loss of capacity is replaced by employing two separate batteries. The batteries are floated alternately for a period of one week, and the idle battery is given a continuous trickle charge during the idle week to restore the capacity lost during the float period. This battery is trickle-charged at a rate such that the charge is terminated between 12 and 18 hours before the change-over of batteries is due to take place. It is found in service that the average loss of capacity during floating is of the order of 3 per cent. per day, which means that the battery must be continuously trickle-charged at approximately the 800 hour rate.

In the event of a mains supply failure, facilities are available for paralleling the batteries if necessary. The employment of two batteries instead of a single battery has an added advantage that battery repair work can be carried out on one battery without interruption of the other. The basis of battery provision is shown in Table 2.

TABLE 2

Ultimate Load Ah per day	Box Capacity of Battery Ah
2,000 to 3,000	1,500
3,001 to 4,000	2,100
4,001 to 5,000	2,600
5,001 to 6,000	3,000
6,001 to 8,000	4,000
8,001 to 10,000	5,000

Note.—The batteries are not necessarily fully plated when installed and initial plating capacity is determined by the daily ampere-hour consumption at the 12-year period.

Automatic Voltage Regulators.

There are two types of auto voltage regulator employed on the Divided Battery Float system—(a) moving coil type, (b) carbon pile type. A further type of the vibrating contact pattern is used by the Post Office, but up to the present it has not been used on telephone exchange power plant installations.

Both types of regulator function on the same principle, the main difference being the method of varying the generator field excitation. Explanatory sketches showing the principles of operation of each type are shown in Fig. 2.

Each type of regulator has a moving system which functions on the "dynamometer" principle, the amount of deflection being dependent on the

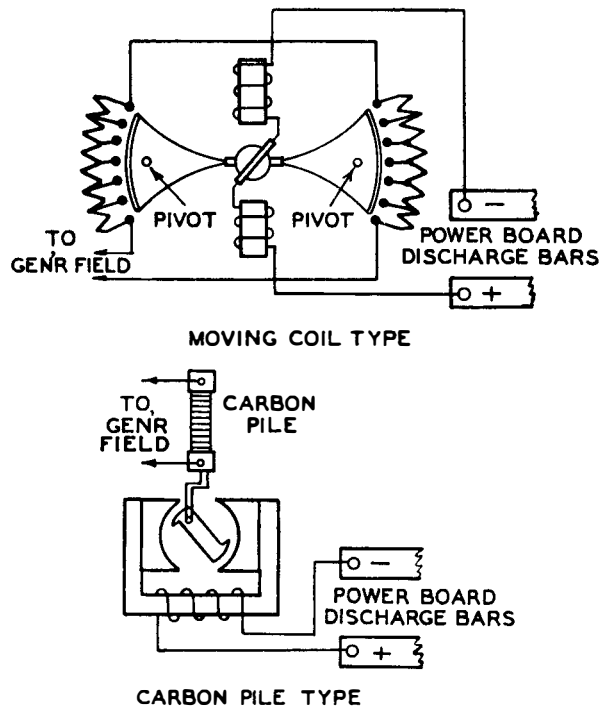

FIG. 2.—AUTOMATIC VOLTAGE REGULATORS.

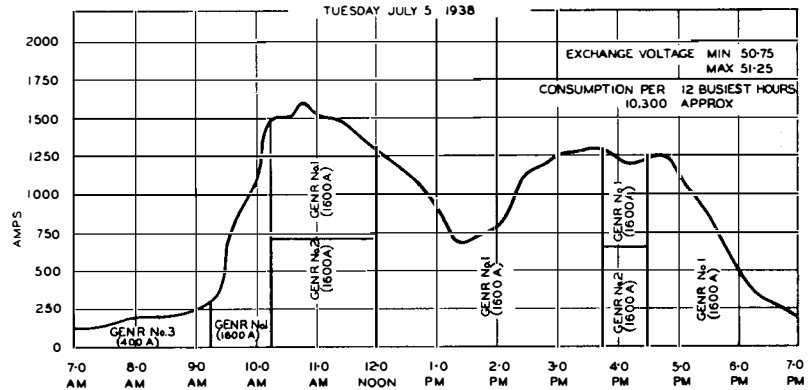

FIG. 3.—TYPICAL DAILY EXCHANGE LOAD.

voltage across the exchange discharge bars. It will be seen from Fig. 1 that any change in battery voltage as a result of load variation, however slight, will cause the auto voltage regulator to vary the generator field excitation and cause the generator output to change according to the load requirements at any given moment. A constant voltage across the battery is thus maintained. A typical performance graph of the efficiency of auto-voltage regulation is illustrated by Fig. 3, which represents an actual daily load record taken at Mansion House and Avenue exchanges, where both exchanges are served by a common power plant operating on the divided battery float system.

Under all conditions of load the exchange voltage variation was within 0.5 volts, and this is typical of the performance at other exchanges where the system is installed.

Motor Generators.

The basis of provision of motor generators is divided into six standard plant sizes as shown in Table 3, using five standard sizes of generators.

TABLE 3.

Ultimate Consumption Ah per day	Number of Motor Generator Sets				
	100 Amps.	200 Amps.	300 Amps.	400 Amps.	500 Amps.
2,000 to 3,000	1	2	—	—	—
3,001 to 4,000	1	—	2	—	—
4,001 to 5,000	1	—	—	2	—
5,001 to 6,000	—	1	—	2	—
6,001 to 8,000	—	1	—	—	2
8,001 to 10,000	—	1	—	—	3

The total output of the machines operating in parallel is required to meet the peak load at the ultimate date and to allow of charge-discharge working temporarily in the event of a failure of the mains supply. The total number of machines is not necessarily installed initially and machine provision is based on the summation of the outputs of the small machine operating in parallel with such others as may be necessary to meet the peak load at the five year period. The small machine is

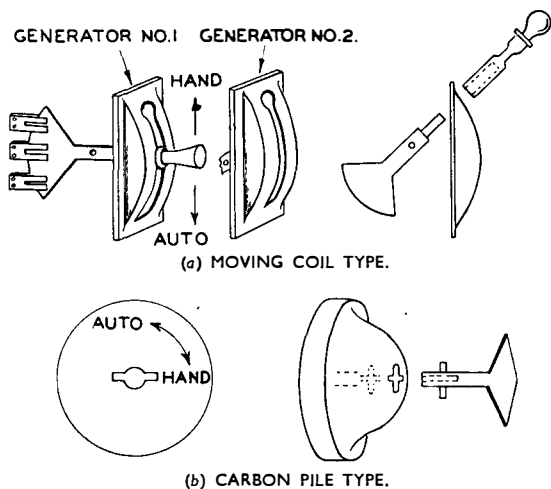

FIG. 4.—AUTO VOLTAGE REGULATOR SWITCHES.

provided for running at night or other periods of light loads to secure high machine efficiency and consequent reduced power costs. An auto voltage regulator is provided for the small machine and for one of the large machines. By means of switches each regulator can be cut out when required and the generator regulated by hand. When two or more machines are operated in parallel, one machine is controlled by its own automatic voltage regulator, and the other, or others, are controlled by hand regulation. The machines under hand regulation are adjusted to share a suitable proportion of the load, and the machine which is controlled automatically will deal with the varying load in excess of the output of the hand-regulated machines. An interesting feature of the switching scheme is shown in Fig. 4.

The automatic voltage regulator switches are operated by a transferable handle which can only be fitted to, or removed from, any switch when it is in the "Hand" regulated position. This arrangement is fool-proof and prevents the possibility of more than one auto-voltage regulator being in use at one time.

When a machine is switched for auto regulation, a portion of the resistance of the hand field regulator is gradually taken out until the automatic voltage regulator takes control. The extent to which the field regulator resistance must be reduced is found by tests when the machines are installed on site and, when determined, the appropriate stud of the field regulator is marked for the guidance of the power attendant and represents the position at which the hand field regulator must always be set when the machine is operating under automatic control.

Audio Frequency Disturbance.

One of the most important features of the divided battery float system is the suppression of generator ripple under floating conditions. To limit the audio frequency disturbance on the exchange under floating conditions, it is specified that the noise E.M.F. produced across the exchange battery shall

not exceed a noise equivalent to 2 millivolts at 800 c/s when the maximum number of machines is operating in parallel and delivering full load to supply the exchange. To meet this requirement each machine is provided with a smoothing filter. The design of the filters varies, since the arrangement is dependent on the electrical characteristics of the generator and the inductance of the battery loop across which the generator is floating. For the purpose of design a curve giving the weighting factor/frequency is issued to the contractor and an average inductance of $20 \mu\text{H}$ for the battery loop is assumed. Psophometric measurements are made at the contractors' works and sometimes also on site to ensure that the specification requirements are met.

Typical filter arrangements are shown in Fig. 5.

It may be of interest to mention that the disposition of the smoothing filters in the power room is of considerable importance, and careful consideration is necessary when planning the layout of the plant to avoid induction from extraneous sources. The position of smoothing condensers in relation to the chokes is also of importance, and it has been found necessary in several exchanges to restrict the route length of the condenser leads to a maximum of 6 ft. and for the cross section of the leads to be not

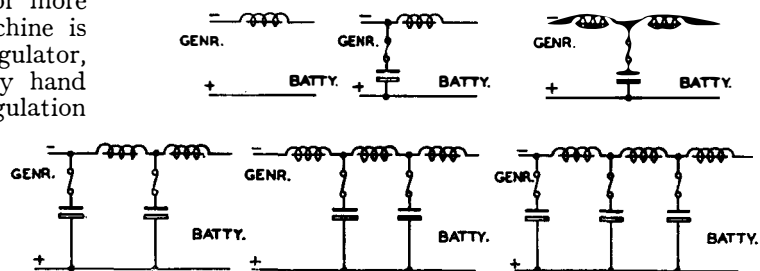

FIG. 5.—TYPICAL CONNECTIONS OF SMOOTHING FILTERS.

less than 0.0225 sq. ins., otherwise the impedance of the leads becomes comparable with the impedance of the condensers. The condenser fuses are rated as high as possible commensurate with the current-carrying capacity of the cable as a further precaution in reducing the impedance of the condenser leads to a minimum.

The circuit arrangements of the divided battery float system are given in Fig. 6.

The switching arrangements on the power board provide the following facilities:—

(a) Either battery can be floated by changing over the "discharge" switch (make-before-break type) together with the appropriate "generator" switch.

(b) By changing over the "parallel" switch under emergency conditions of mains power supply failure, both batteries are connected in parallel to secure the maximum capacity on discharge.

(c) One or more machines can be simultaneously used for floating either battery.

(d) When the exchange load is within the capacity of one machine, the generator switches of the machines not in use allow the battery not on

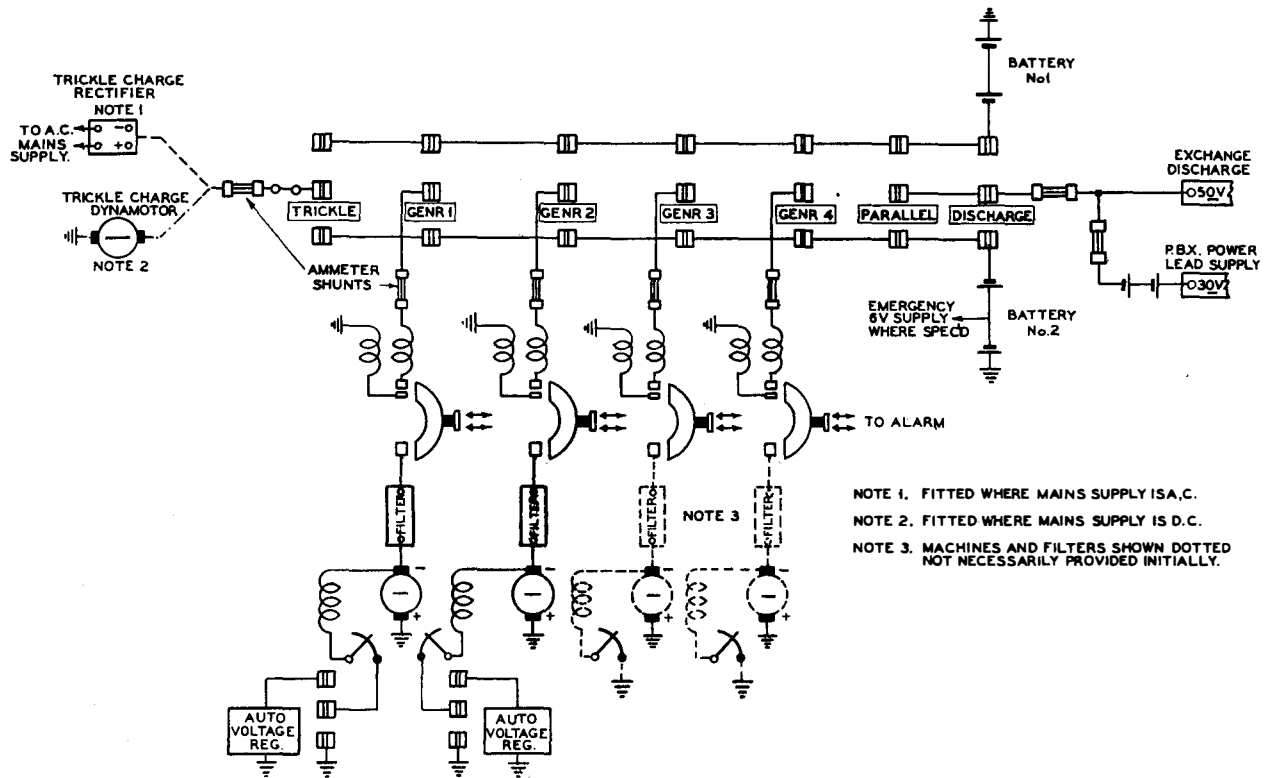

FIG. 6.—CIRCUIT ARRANGEMENTS, DIVIDED BATTERY FLOAT SYSTEM.

float to be charged. This permits re-charging either battery following discharge due to mains supply failure, etc. Any machine not floating at any given time will be available for charging. Emergency operation on this basis provides sufficient capacity to meet the load requirements.

The power board is equipped with an overload and reverse current circuit breaker for each machine and each circuit breaker is fitted with contact springs to provide an alarm in the event of the circuit breaker being tripped.

The main discharge bus-bars to supply the exchange are designed to carry the peak load current at the ultimate date, and the cross-sectional area of the conductors is based on a potential drop of one volt between the battery lugs (including fuse or breaker) and the furthest feeder point in the exchange.

50-volt Positive Battery Supply.

Where this supply is required the method of provision is determined by the load requirements. Dry cells are used when the load is light, otherwise the supply is furnished from a small single battery of 25 secondary cells. The circuit arrangements are shown in Fig. 7.

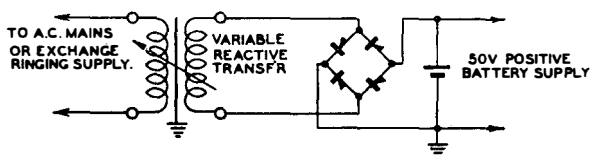

FIG. 7.—50V POSITIVE BATTERY SUPPLY CIRCUIT.

The battery is continuously trickle-charged from a small copper oxide rectifier having an adjustable output of 57 V, 0.25 amps. Where an A.C. 200/250 volt, 50 c/s mains supply is not available, the rectifier is fed from the continuous ringing supply. The trickle-charge rate is determined by the average daily load and is adjusted to such a value that any loss of capacity during the day shall be restored to the battery within the remainder of the 24 hours.

An interesting feature of the rectifier is the method by which the D.C. output is adjusted, the rectifier being fitted with a variable reactive transformer which is so constructed that the yoke is adjustable. This permits the air gap to be varied and thereby alters the reluctance of the magnetic circuit. The secondary voltage to the rectifier can therefore be increased or decreased as required.

6-volt Supply.

This supply is required for multiple answering and free line signal lamps. These loads are generally small even for large exchanges and have in the past been supplied from a tap off the main batteries. This arrangement is not used in floating systems owing to the desirability of maintaining the whole of the main battery in a fully charged condition.

Multiple Answering Lamps.—Where the mains supply is D.C., a separate 6-volt battery is used. The battery is charged from the 50-volt exchange supply through a resistance under the control of an ampere-hour meter.

Where the mains supply is A.C. the normal 6-volt supply is served direct from the mains via a step-down transformer, and a 6-volt tap on the main battery is provided for emergency use under mains failure conditions.

Free Line Signal Lamps.—Where mains supply is D.C., power is provided from the main 50-volt battery and groups of the 6-volt lamps are connected in series with suitable dropping resistances. Where the mains supply is A.C. the normal supply is served direct from the mains via a step-down transformer. No stand-by supply is provided under mains supply failure conditions as the operators can revert to the "click" engaged test.

Explanatory circuit arrangements of the 6-volt supply are shown in Fig. 8.

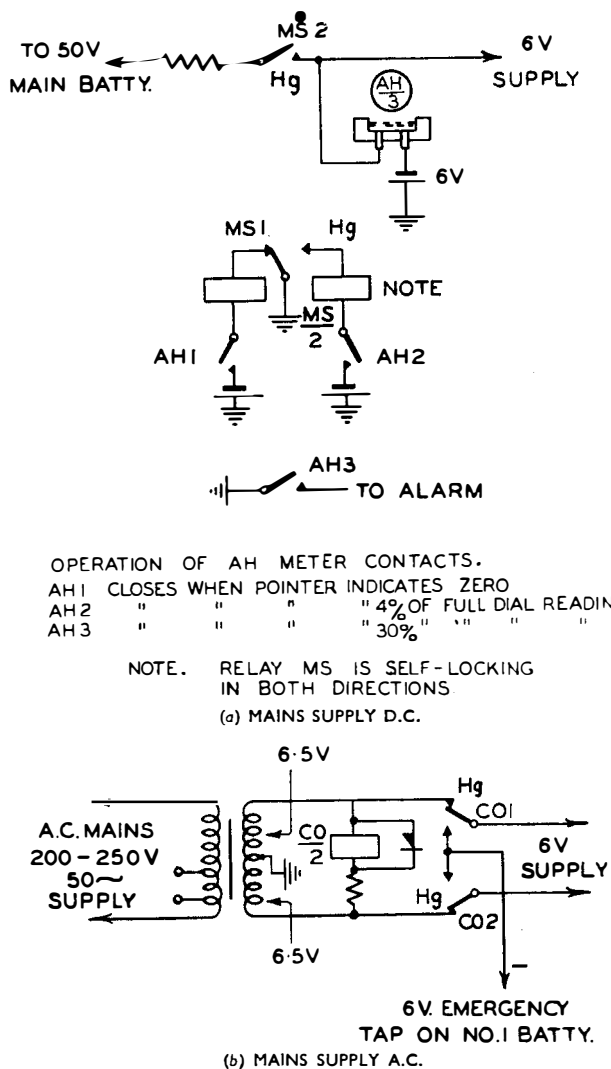

FIG. 8.—6-VOLT SUPPLY ARRANGEMENTS

Power Lead Supply.

The supply for P.B.X. power leads is obtained from the main floating battery via seven counter E.M.F. cells. The current carrying capacity of the cells is based on the P.B.X. peak load at the ultimate date.

PARALLEL BATTERY AUTOMATIC SYSTEM

This system is generally installed at medium size director and non-director exchanges and at exchanges of the U.A.X. No. 14 type. The system is fully automatic and requires no attention beyond periodical cleaning and battery inspection.

The operation of the system differs from the divided battery float system in that single battery working is employed and an alternative method of auto-voltage regulation is used. The main battery comprises two batteries paralleled and connected to the exchange bus-bars. The reason for employing two batteries instead of one is to enable battery repairs to be carried out to either battery without interruption of the supply to the exchange.

Main Battery.

The battery capacity provided is based on approximately a 24-hour reserve being available, and to effect this the total battery capacity is about 10 per cent in excess of that required for the daily load. On the basis of an automatic exchange having an ultimate life of twenty years, five standard sizes are employed as shown in Table 4.

TABLE 4

Ultimate Load Ah	Battery Capacity Ah
100 to 200	120 + 120
201 to 550	300 + 300
551 to 900	500 + 500
901 to 1,450	800 + 800
1,451 to 2,000	1,100 + 1,100

Circuit Operation.

Owing to the comprehensive nature of this circuit and limitation of diagram space, it is not possible to give a detailed circuit description of the system, but for simplicity, the main operating principles only will be described.

An abridged circuit diagram is shown in Fig. 9.

The main battery is connected to the exchange supply feeders, via the ampere-hour meter, which is actuated in reverse directions by charge and discharge currents. The ampere-hour meter is fitted with three local contacts which are arranged to close as follows:—

- AH 1 when the pointer indicates zero.
- AH 2 when the pointer indicates 4 per cent. of the full dial reading.
- AH 3 when the pointer indicates 30 per cent. of the full dial reading.

To give an excess charge over discharge the meter is 20 per cent. slower in the charge than in the discharge direction.

The charge is controlled by a mercury tube switch, which in turn is controlled by the ampere-hour meter.

Four sets of counter E.M.F. cells, normally short-circuited by four contactors, are inserted in the discharge circuit to the exchange as required to keep the bus-bar voltage within the prescribed limits of 46 V–52 V when the battery voltage rises due

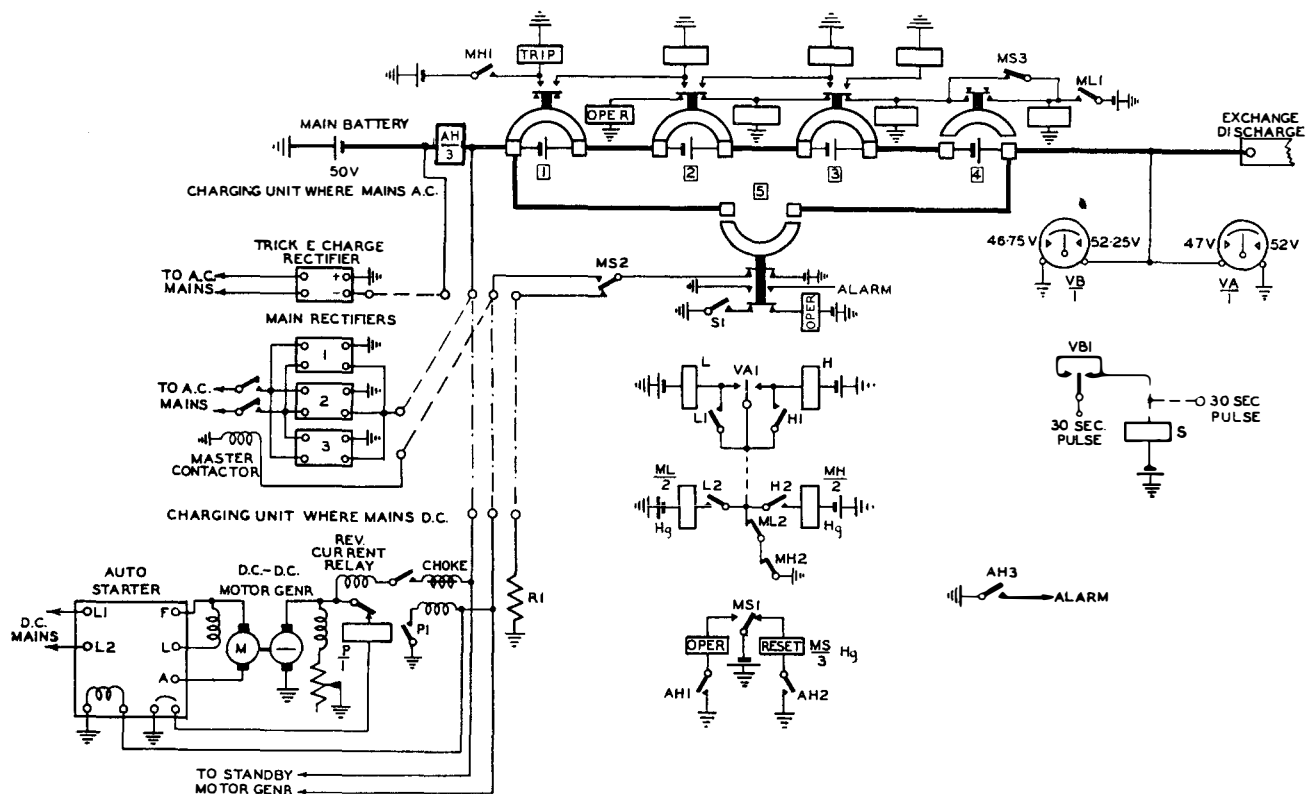

FIG. 9.—CIRCUIT ARRANGEMENTS OF PARALLEL BATTERY AUTOMATIC SYSTEM.

to the charging current. The contactors are mechanically latched when operated, and are tripped and operated as required by mercury tube switches under the control of a contact voltmeter.

To make good local action losses of the main battery and leakage discharges too small to operate the ampere-hour meter, the battery is given a constant trickle charge. A small rectifier is used for this purpose where the public supply is A.C. Where the public supply is D.C. a small permanent load R1 is connected at such times as the battery is not being charged and ensures that the ampere-hour meter does not remain stationary.

Circuit Notes.

When 4 per cent. of the battery capacity has been discharged AH 2 closes and operates relay switch MS, which changes over its mercury tubes. MS2 controls the input to the charging unit which then starts up. If the exchange load exceeds the output of the charging unit the whole of the latter is absorbed by the load, the deficit being obtained from the battery and duly recorded on the ampere-hour meter. If the exchange load is less than the output of the charging unit the surplus serves to charge the battery. Charging continues until the ampere-hour meter indicates zero, when AH 1 closes to restore switch MS and shut down the charging unit.

During the charging period the exchange voltage rises to the upper limit (52 volts). VA 1 then closes and operates relay H. H 1 holds relay H and guards the voltmeter contact against sparking. MH operates and causes H and MH to restore. The mercury in

tube MH 2 is trapped and takes approximately five seconds to make the contact. Immediately MH operates, MH 1 closes and completes the trip circuit of the 1st contactor. The mercury of tube MH 1 is trapped and takes approximately five seconds to break the contact. When the first contactor trips it removes the short-circuit across the one group of counter E.M.F. cells, the voltage of which quickly builds up and reduces the busbar voltage so that the contact voltmeter assumes an intermediate position.

The C.E.M.F. cells used are of the alkaline type and are specially designed to meet the circuit requirements. Each cell consists primarily of two plate sections comprising a number of mild steel plates, nickel plated, immersed in a solution of pure potassium hydroxide (KOH) in distilled water, the whole being housed in a glass container. The cells may be regarded as having no capacity and can be short-circuited with impunity. The current under short-circuit conditions is not sustained but diminishes to zero within a few seconds of the short-circuit being applied. On removal of the short-circuit and when current is allowed to pass through the cell, an E.M.F. dependent on the value of current passing through the cell is brought up within a few seconds. The working voltage range of each cell is 1.5 to 2 volts. Approximately 10 seconds after the contactor is tripped the auxiliary contacts close to prepare the trip circuit of the second contactor. Subsequent voltage rises during the charge period cause re-operation of relay H and relay switch MH, and trip contactors Nos. 2, 3 and 4 in turn cutting in the appropriate counter E.M.F. cells.

When the busbar voltage falls to the lower limit, VA 1 closes and operates relay L. Relay switch ML operates and restores immediately in a manner similar to relay switch MH. The contactors operate in turn, in the reverse order to which they were tripped and short-circuit the counter E.M.F. cells.

Should the high or low voltage condition persist due to failure of a contactor or other causes, relay S is operated from the 30-second time pulse to complete the circuit for contactor No. 5. The operation of contactor No. 5 causes the charging unit to shut down via its auxiliary contacts, and also short-circuits all counter E.M.F. cells in the discharge circuit, so that the exchange is connected directly to the battery which is not now on charge and therefore its voltage is nominal. An alarm is also given. Contactor No. 5 is reset manually, but special features in the design of the contactor permit of re-setting the contactor partially to enable the sequence of operations of the contactors 1 to 4 to be tested without disturbing the voltage across the exchange. At the end of charge the battery voltage falls rapidly and it is necessary to cut out two groups of counter E.M.F. cells together. If the fourth group of cells is in circuit, MS 3 enables contactors Nos. 3 and 4 to operate together and short-circuit groups 3 and 4 simultaneously.

In the event of failure of the charge, or a heavy load causing the battery to discharge more than 30 per cent., an alarm is given via AH 3.

If a high or low voltage condition fails to complete the circuit condition controlled by voltmeter VA, the duplicate voltmeter VB operates via the 30-second pulse and operates contactor No. 5 as already described.

Charging Units.

Where the public supply is A.C. the charging current is supplied by three rectifier units connected in parallel. The rectifiers are usually either of the mercury arc or copper oxide types. Two rectifiers are provided initially and provision is made for a third at a later date to meet the ultimate requirements. The sizes of rectifiers are divided into five standard sizes as shown in Table 5.

TABLE 5

Ultimate Load Ah per day	Nominal Current Output amps.
101 to 200	5
201 to 550	15
551 to 900	22.5
901 to 1,400	35
1,401 to 2,000	50

The input connections to the rectifiers are paralleled and controlled by a master contactor which is operated by the ampere-hour meter via MS 1. The rectifiers are thus automatically started up when 4 per cent. of the main battery capacity has been discharged. When the battery is fully charged MS 1 releases, followed by the master con-

tactor, which disconnects the mains supply to the rectifier. Each rectifier is fitted with a suitable smoothing filter to suppress audio-frequency disturbance.

The trickle-charge unit is of the copper oxide type, and three standard sizes are used as shown in Table 6.

TABLE 6

Ultimate Load Ah per day	Nominal Current Output amps.
101 to 200	1.5
201 to 550	1.5
551 to 900	3
901 to 1,400	3
1,401 to 2,000	5

At exchanges where the mains supply is D.C. the charging current is served by a D.C.-D.C. motor generator which is equipped with an automatic two-step starter. When the machine is automatically started up, relay P remains unoperated until the generator voltage builds up to a value slightly in excess of the battery voltage. This prevents an undesirable rush of current in the output leads when the circuit is completed.

The output of the machine is capable of meeting the load requirements at the ultimate date. Two machines are provided initially, one being used for normal working and the other to function as a stand-by in the event of a breakdown of the other.

Audio-frequency disturbance is suppressed by the insertion of a smoothing filter connected in the generator output circuit.

Where required the arrangements for the 50-volt positive, 6-volt negative supply and P.B.X. power leads are similar to those already described for the divided battery float system.

SINGLE BATTERY AUTOMATIC SYSTEM

This power plant system is the present standard for exchanges of the U.A.X. No. 12 and 13 types at which an A.C. supply is available. The plant is fully automatic and embodies somewhat similar principles to those of the parallel battery automatic system. Since the peak exchange load is generally light, the provision of heavy duty contactors with associated control equipment for short-circuiting the C.E.M.F. cells cannot be economically justified. Mercury tube switches of the make-before-break type are employed for switching in or out the C.E.M.F. cells which are of the lead acid type. Lead C.E.M.F. cells cannot be short-circuited without damage, and a low resistance is inserted in the circuit during the switching operation to limit the current while the cells are cut in or out. Two sets only of C.E.M.F. cells (two cells per set) are used, which further simplifies this system. The average voltage attained by the cells is 10, and to ensure, therefore, that the exchange voltage does not exceed 52, the battery voltage must not exceed 62. Experience has shown that using a 25-cell battery, a final voltage of 62 will be reached at the end of the charge if the cells are charged at approximately the

130-hour rate. The average output of the charging unit must be capable of furnishing the daily load plus a margin for battery efficiency in 24 hours.

On light loads during the charge period, the battery will receive the maximum charge current; and to ensure that the end-of-charge voltage does not exceed 62, the battery capacity would require to be approximately six times the daily ampere-hour consumption. A battery of 24 cells is therefore used which can be charged at the 75-hour rate and the maximum voltage not exceed 62. To fulfil these conditions a charging unit with an average output of the 60-hour rate is provided. Since the charging unit must be capable of supplying the ultimate daily load in 24 hours, the battery capacity must be approximately three times the daily load in ampere-hours. It will be seen that the battery provision is greater in proportion than that of the parallel battery auto system for a given daily consumption, and therefore the single battery auto system is limited to small installations on economical grounds.

All the plant details are standard rate book items and installation is carried out by the Post Office.

Four standard sizes of plant are employed, and the basis of provision is shown in Table 7.

TABLE 7

Maximum Load Ah per day	Battery Capacity Ah	Rectifier Output amps.
15	50	0.75
30	75	1.5
60	200	3.0
100	300	5.0

The circuit arrangements are shown in Fig. 10.

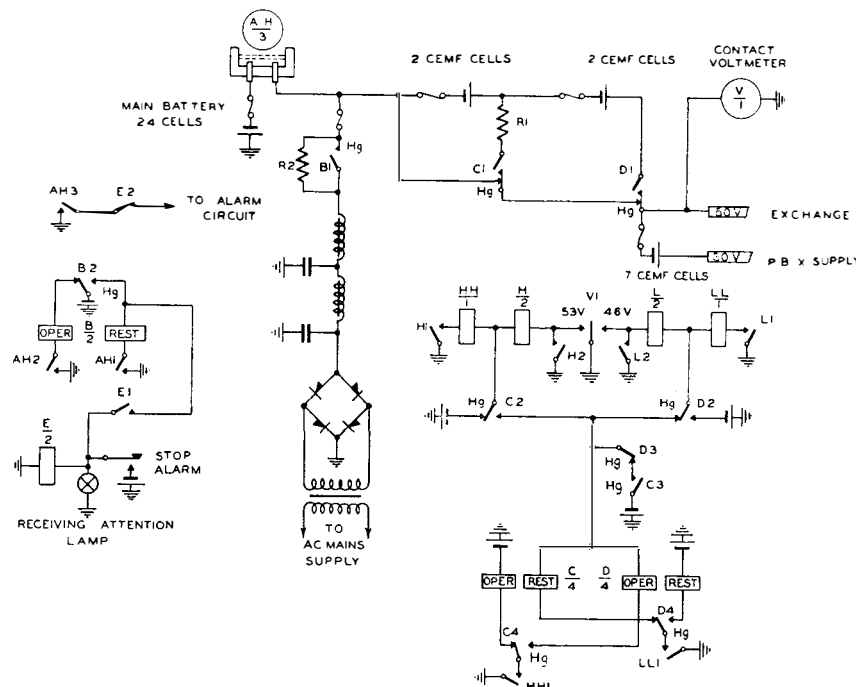

FIG. 10.—CIRCUIT ARRANGEMENTS OF SINGLE BATTERY AUTOMATIC SYSTEM.

Operation.

When the ampere-hour meter records a discharge of approximately 4 per cent. of the full dial reading, contact AH2 closes and causes the operation of switch B via B2. B1 connects the rectifier (supplying current at approximately the 60-hour rate) in parallel with the battery. Charging continues until the meter indicates "0" when contact AH1 closes and causes switch B to disconnect the charging current and the cycle of events is repeated. Switch B is self-locking in both directions.

When the voltage across the exchange equipment rises to the upper limit, due to the battery being on charge, relay H will operate, and H1 operates relay HH. Switch C is operated and mercury tube C1, which is "make before break," cuts in the first group of C.E.M.F. cells via an 0.1 ohm resistor (R1) and reduces the voltage across the exchange equipment. The contact voltmeter assumes an intermediate position, and contact V1 releases. Mercury tube C2 disconnects battery from relays H and HH, which release. After a period of 5 to 10 seconds, mercury tube C3 connects battery to the operate solenoid of switch D and to the restoring solenoid of switch C, in readiness for a further rise or fall of voltage. If a further voltage rise to the upper limit occurs, relays H and HH re-operate. Switch D is operated and D1 cuts in the second group of C.E.M.F. cells. D3 disconnects battery from relays H and HH, which release.

When the voltage falls to the lower limit, relays L and LL operate. Switch D restores and D2 causes relays L and LL to release and cut out the second group of C.E.M.F. cells. When only the first group of C.E.M.F. cells is in circuit, and the exchange voltage falls to the lower limit, a similar sequence of operations results in the release of switch C. Tube C1 switches out the first group of C.E.M.F. cells.

The main battery is given a continuous trickle charge via R2 to cover line leakage which may be below the minimum operating current of the ampere-hour meter and also serves as compensation for local action. The trickle charge is adjusted to approximately the 1,000-hour rate of the main battery.

In the event of a failure of the charge or a heavy load causing the battery to discharge more than 30 per cent. an alarm is given via AH3.

Audio-frequency disturbance is suppressed by a small filter consisting of a coil retard and two electrolytic condensers connected in the output of the rectifier. The connections shown are typical only and are varied according to the size of plant installed.

When required, the positive battery supply is obtained from a

small battery of 39 primary cells.

DOUBLE BATTERY CHARGE-DISCHARGE SYSTEM

The operating principles of the charge-discharge system are already well known, but their application to the power plant used for small automatic exchanges presents several interesting features which justify a description of the arrangements made and the facilities provided. The charge-discharge system is the present standard for small automatic exchanges where:—

(a) An A.C. mains supply is not available.

(b) The ultimate daily load does not exceed 100 ampere-hours.

At exchanges where a D.C. mains supply is available the charging unit is a dynamotor or motor generator (dependent on the size of installation). Where a mains supply is not available the charging unit is a petrol engine set. The batteries are charged and discharged alternately, the circuit conditions being set up manually at the commencement of a charge and disconnected automatically at the end of a charge. Since the small types of exchanges for which this system caters, are normally unattended and frequently situated in remote areas, long journeys are often involved in travelling to the exchange to set up the charging conditions for the battery. From this point of view, together with the periodical attention required to the petrol engine set and machines, the maintenance charges are much greater than those for the single battery automatic system already described. Furthermore, the employment of two batteries increases the cost of plant per installation. On these two factors alone it has been found that the savings effected by the single battery automatic system are such that high leading-in charges for the provision of the A.C. mains supply can be economically justified. The charge-discharge system is therefore only installed where an A.C. supply is actually unobtainable or where the cost of such is prohibitive.

Four standard sizes of plant are employed, and the basis of provision is shown in Table 8.

Charging Units.

The motor generator used for D.C. mains supply consists of a D.C. motor directly coupled to a D.C. shunt-wound generator. The output of the generator is hand regulated by a field rheostat mounted on an angle iron panel adjacent to the machine. A circuit breaker is connected in the input leads of the motor to facilitate the shutting down of the machine automatically at the end of a charge.

The dynamotor used for D.C. mains supply consists of a combined motor and generator arranged in one casting with a common field and a double-wound armature. The armature has two distinct

TABLE 8.

Maximum Load Ah per Day	Capacity of each Battery Ah	Charging Unit			
		D.C. Mains Supply Available		No Mains Supply Available	
		Type	Output	Type	Output
15	50	Dynamotor	52/62 volt 7·2/4·5 amp.	Petrol Engine Set	50/68 volt 10/8 amp.
30	125	Dynamotor	52/62 volt 18/11·5 amp.	Petrol Engine Set	50/68 volt 30/24 amp.
60	200	Motor Generator	50/68 volt 30/22 amp.	Petrol Engine Set	50/68 volt 30/24 amp.
100	300	Motor Generator	50/68 volt 30/22 amp.	Petrol Engine Set	50/68 volt 30/24 amp.

windings, each with its own commutator, one commutator being fitted at each end of the rotor. The machine output is hand regulated by a brush rocker which enables the position of the brushes to be altered. To avoid the necessity of manual regulation of the output during the progress of charging the battery (during which time the maintenance officer may not be in attendance), a "compensator" which consists of a number of iron wires connected in parallel is inserted in series with the negative output lead of the machine. As the charge progresses the battery voltage rises, and unless the output voltage of the machine were increased or, alternatively, the resistance of the charging circuit reduced, the charging current would diminish to a low value and unduly prolong the time required to complete the charge. The "compensator" functions to prevent the current diminishing, and its action is due to the temperature coefficient of iron, in that its electrical resistance rises rapidly as its temperature is increased. The temperature of the iron wire in the compensator is controlled by the current flowing through it. At the beginning of the charge, when the current has its greatest value, the temperature and resistance of the wire are at their maximum values. As the battery voltage rises during the charge and the charging current consequently falls, the temperature and resistance of the iron wire decrease and the charging current is automatically maintained at a satisfactory value throughout the charge.

The petrol engine sets used where a mains supply is not available are of the water-cooled 2-stroke type. The engine is directly coupled to a shunt-wound generator. Two types of engine are employed, one having a gravity petrol feed and the other having a pump petrol feed. To cover fire risk the fuel tank is fitted on the wall outside the building. The engine is stopped at the end of a charge by an electrically operated mechanically locked relay, which cuts off the petrol supply to the engine. The relay is fitted outside the building with the petrol tank, and ensures that no petrol remains inside the building when the engine is stopped. The water circulation system is provided by a water tank situated inside the building, and the engine exhaust is led away to the outside of the building by piping through a hole

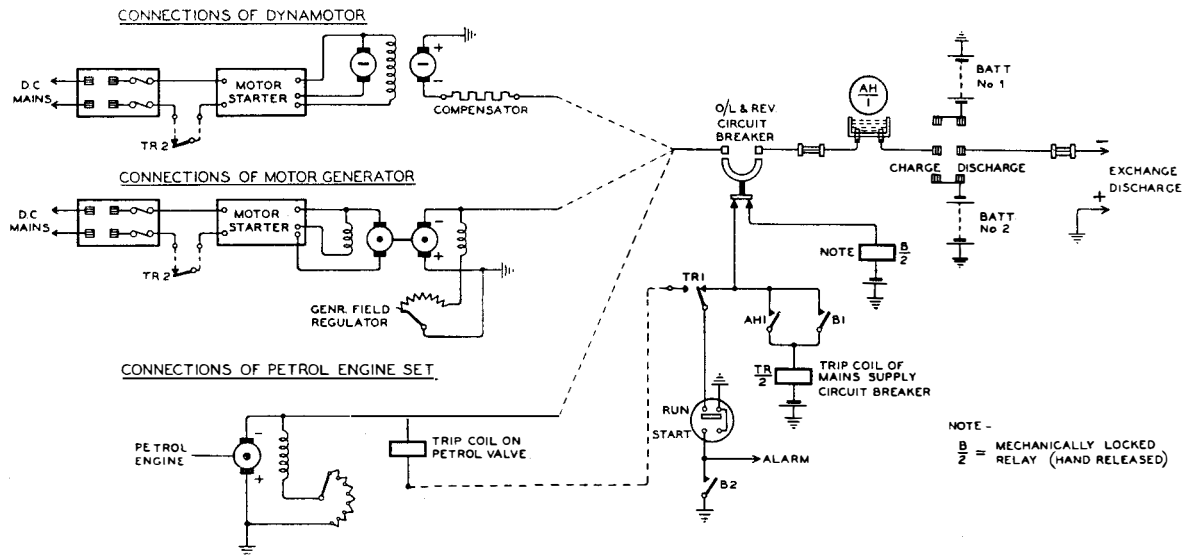

FIG. 11.—CIRCUIT ARRANGEMENTS OF CHARGE-DISCHARGE SYSTEM.

in the wall. The lubrication is effected by the "petroil" system.

The circuit arrangements are shown in Fig. 11.

Circuit Operation.

The tumbler switch is placed in the "start" position and the ampere-hour meter set to the requisite number of ampere hours to be put into the battery. After the charging unit has been started up, the generator voltage is adjusted to exceed slightly that of the battery to be charged. The charge switch is then thrown and the circuit breaker manually closed. When a slight charging current is observed on the ammeter, the machine output is adjusted to the correct charging rate and switch thrown to the "running" position.

When Petrol Engine Set is Used.—During the charge condition contacts of relay B are open and the circuit breaker is closed. At the end of the charge the ampere-hour meter contact AH1 closes and operates trip coil TR. TR1 operates the trip coil on the petrol valve which disconnects the petrol supplied to the engine. The engine continues to run for a short period until the petrol in the petrol chamber is used up, and then shuts down. The battery is then automatically disconnected from the generator by the circuit breaker.

When a Dynamotor or Motor Generator is Used.—During the charge conditions the contacts of relay B are open and the circuit breaker closed. At the end of charge, the ampere-hour meter contact AH1 closes and operates trip coil TR. TR2 disconnects the input supply to the dynamotor or motor generator which then shuts down. The battery is then automatically disconnected from the generator by the circuit breaker.

Charge Fail Alarm.—If the charging current fails during charge the circuit breaker releases and disconnects the battery from the generator. A circuit is then completed for relay B via the auxiliary

contacts of circuit breaker. When relay B operates a circuit is completed for the alarm from earth at B2. B1 completes a circuit for TR, and TR completes a circuit for shutting down the charging unit at TR1 (if a petrol engine set is used) or TR2 (if a dynamotor or motor generator is used).

Operation of Circuit Breaker.

The circuit breaker is closed manually and held mechanically during charging. The circuit breaker is fitted with a series coil and shunt coil. The series coil is connected in the negative charging lead and the shunt coil is connected across the positive and negative charge leads. During the charge condition the charging current passes through both coils in such direction that the windings are magnetically opposed. When the charging current falls to zero i.e., on completion of the charge or failure of the charge current, a current from the battery is built up through the series winding in the opposite direction, and this change of direction of current reverses the magnetic flux of the series coil. As there is no change in the polarity of the circuit the flux due to the shunt coil remains in the same direction as before. The two coils are no longer in magnetic opposition, and under these conditions the circuit breaker is tripped.

Conclusion.

The new power plant systems described in this article have proved satisfactory in service, and since their introduction it has been found economical to convert several existing exchange power plant installations from the charge-discharge system to the new divided battery float system. In these exchanges the existing plant has been utilised and the modifications have enabled far greater exchange loads to be carried than hitherto with but little cost for additional plant. Furthermore, for the converted installations maintenance charges have been reduced considerably.

Replacement of the Main Aerial System at Rugby Radio Station

F. HOLLINGHURST, B.Sc. (Eng.), A.M.I.E.E.
and H. F. MANN

U.D.C. 621.396.67

The authors describe the design of new aerials to replace those which had been in service on the long wave telegraphy transmitter at Rugby since 1926, and the method by which the aerials were erected without damage to themselves or interruption to other services.

Introduction.

THE original aerial system at Rugby Radio Station used in connection with the long-wave telegraphy transmitter (call sign GBR) was erected in 1925, and was brought into regular service in January, 1926. This aerial system consisted of a number of "sausages" in series and was supported on eight 820 ft. masts to the south of the station buildings arranged 440 yards apart in the form of an irregular octagon. Each span of this aerial was composed of eight 7/14 S.W.G. bronze wires symmetrically spaced at 6 ft. radii around a centre stranded steel triatic wire by ten steel spreaders. The connection between the aerial and the building was by eight similar wires in the form of a 6-in. diameter trunk.

In 1926 a shorter aerial was completed for the long-wave trans-atlantic telephone service on the two 820 ft. masts to the north of the station buildings. The spans of this aerial were also composed of eight 7/14 S.W.G. stranded wires arranged at 6-ft. radii round a centre stranded steel triatic wire, but the aerial wires were of copper-clad steel, known as "copper weld."

At the end of 1927 the long-wave telegraphy aerial was extended via an external connection consisting of twelve 7/16 S.W.G. bronze wires spaced round 6-in. diameter aluminium spreaders, passing over the building and then dividing into two 6-in. diameter trunks to new spans between the remaining outer pairs of masts on the north side of the station buildings. These spans were made up of six 7/16 S.W.G. bronze wires on 6-ft. diameter spreaders supported by a stranded steel wire, and were continued from the mast for 800 ft. to meet the lead-up trunk.

A third aerial was erected early in 1927 for the medium wave telegraph transmitter, and comprised a T aerial immediately above the buildings. It consisted of six 7/16 S.W.G. bronze wires arranged on 6-ft. diameter spreaders supported by a stranded steel wire triatic stay.

The area within the 820 ft. masts is crossed at various points by pole routes carrying transmission lines connecting the short-wave aerials on other parts of the site. An overhead 416 V, 3-phase power line also crosses the area.

Construction of the Old Aerial.

The main telegraphy aerial consisted of seven "sausages" or spans in series, each span being one-quarter mile long

and supported between adjacent mast halyards. Each span was constructed of eight 7/14 S.W.G. bronze wires supported at regular intervals by ten 12 ft. diameter spreaders mounted on a 2.625 in. circumference steel wire rope. The spreader was constructed of ½ in. diameter high tensile strength steel tube, carried by two independent split hubs which were clamped on to the triatic wire. Near the ends of each span were spreaders 2 ft. in diameter. The 7/14 S.W.G. bronze aerial wires were fastened to bronze pillars attached to the radial arms of the spreaders, by copper binding wire and, at the ends of the spans, were clamped to the steel triatic wire by bronze clamps. At points midway between spreaders the aerial wires were connected by a circumferential 7/19 S.W.G. bronze wire to minimise relative displacement of the component wires of each span. The spans were connected at each mast insulator by shackling the triatic wires and the insulator together; each of the aerial wires in one span was connected to the corresponding wire in the adjacent span by a "married" joint.

Fault History.

In May, 1934, the 6-in. aluminium spreaders in the long-wave telegraphy aerial lead-up trunk failed due to disintegration. The spreaders were found to have become very brittle and, when subjected to mechanical stress, broke into minute pieces. This fault was due to impurities in the aluminium. The

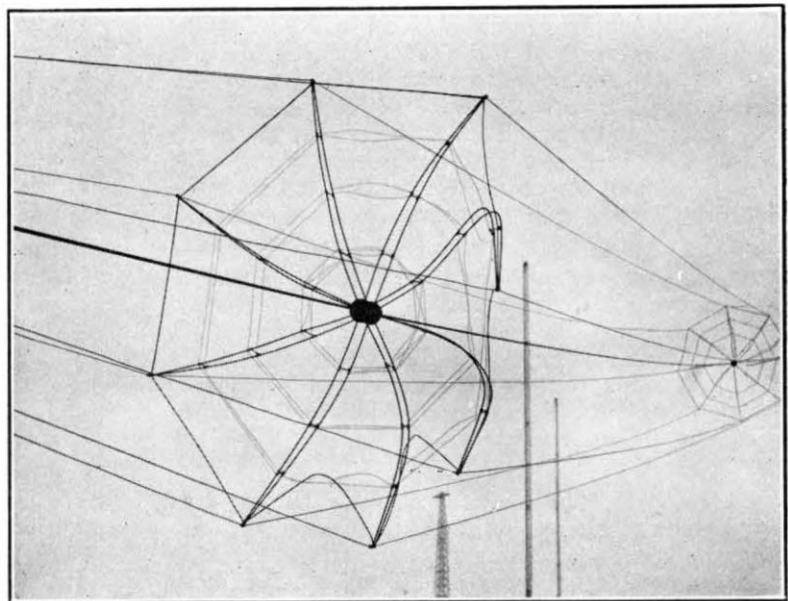

FIG. 1.—OLD DISTORTED SPREADER BEING LOWERED.

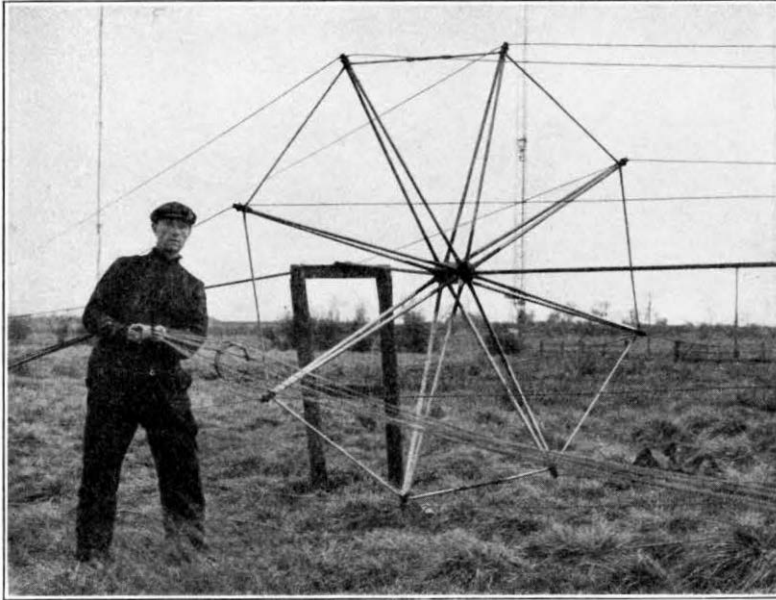

FIG. 2.—NEW SPREADER.

aluminium obtainable when these spreaders were manufactured was evidently below the high standard of purity required for external use. These aluminium spreaders were replaced by phosphor bronze spreaders.

At the end of 1936 the 12 ft. diameter aerials showed signs of deterioration. Friction between the aerial wires and the circumferential wires midway between the spreaders had worn through several strands of the aerial wires in many places, and in a few places the aerial wires were completely severed. The spreaders at each end of several spans had distorted into a saucer shape, and in some spans one or two aerial wires had severed or had become detached from the spreaders.

During the summer of 1937 the spans were each lowered in turn and, as a temporary measure, the end 12 ft. spreaders of each span were replaced by spare 12 ft. diameter spreaders modified to 9 ft. diameter, the broken wires were repaired and the loose wires fastened to the spreaders where necessary. In some places, spreaders were strengthened by the addition of wire bracing. At the same time a thorough examination of the spans was made. As a result of this examination it was decided to renew the aerial wires and spreaders. The wires were found to have broken strands at the places where they passed round the spreader fixing pillar and atmospheric corrosion had considerably weakened the spreaders. The galvanised steel triatic wires, however, were found to be in good condition. Fig. 1 shows an old distorted spreader which has been braced with wire being lowered for final replacement.

Details of the Design of the New Aerial.

The design of the new aerial was prepared by the Post Office. It was decided that a reduction in the diameter of the sausages from 12 ft. to 8 ft. would not affect the performance of the whole aerial to any appreciable extent, but would permit of a very considerable increase of strength being attained. The new design accordingly incorporated a more robust spreader (Fig. 2) which was 8 ft. in diameter.

The old type of spreader was carried on two independent hubs, and one cause of failure was that relative rotation of the hubs (due to the slackening of the grip on the steel triatic wire) seriously weakened each radial arm as a cantilever. Further, each arm in itself, although strong in an axial direction, was relatively weak in the plane of the spreader.

The new spreader consists of a single fabricated steel hub, with radial arms of $\frac{3}{8}$ in. (outside diameter) tube. The strength of each arm is ample in all directions. The hub and tube sockets, and also the hub clamps for fastening the spreader to the triatic wire, were welded. The radial tubes were soldered and pinned to the tube sockets, and the arms were braced circumferentially with $\frac{3}{8}$ -in. (outside diameter) tubes. A steel pillar for attaching the aerial wires was provided at the end of each radial arm. An experimental spreader was tested at Rugby by clamping the spreader hub to a steel wire rope and loading the arms in an axial direction. The test revealed that some strengthening was still needed at one or two joints, and when the necessary modifications had been carried out, the modified spreader withstood a load of 800 lb. on each arm. The final

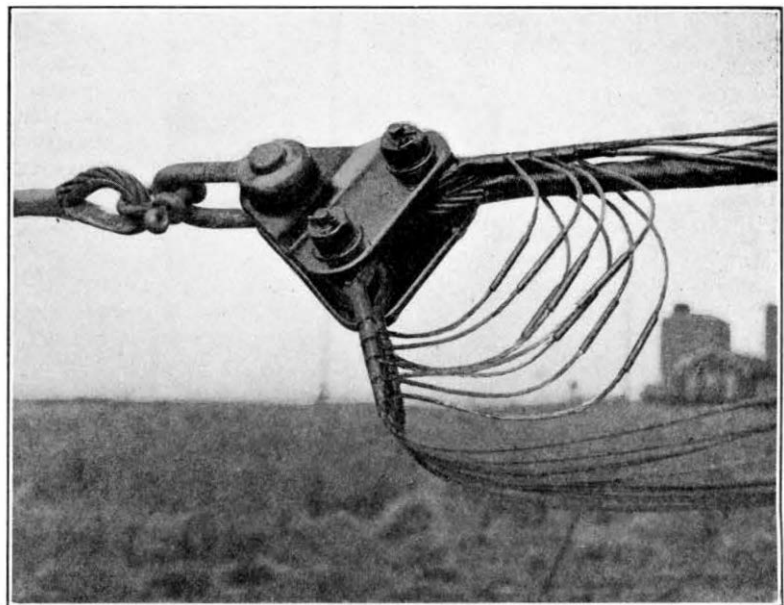

FIG. 3.—TRIANGULAR COUPLING FOR LINKING ADJACENT SPANS.

spreaders were protected from atmospheric corrosion by galvanising.

To improve the method of linking adjacent spans and the aerial insulator at each mast, a triangular coupling was developed from a suggestion submitted by members of the Rugby external staff. The coupling is illustrated in Fig. 3. A 2-in. hole accommodates the pin of the shackle by which the aerial is suspended from the insulators, and the 1½-in. bolts, which are fitted with sleeve distance pieces, accommodate the aerial triatic and the aerial wires. The eight aerial wires are terminated on two thimbles, four wires on each, and are threaded on the bolt with one each side of the triatic wire. This coupling ensures that the three forces at the outer end of the insulators are in one plane, and each aerial wire is firmly anchored.

The aerial insulators comprise four porcelain tubes 3 ft. long by 6 in. diameter arranged as shown in Fig. 4. These insulators had previously been joined together in the centre by rigid steel plate links giving flexibility in one plane only, but, to relieve the insulators of bending stresses, three-link chains are now fitted in the centres.

The connecting trunks between the aerials and the transmitter lead-out formerly consisted of eight 7/14 S.W.G. bronze wires attached to 6-in. diameter bronze spreaders, supported on a 1.875-in. circumfer-

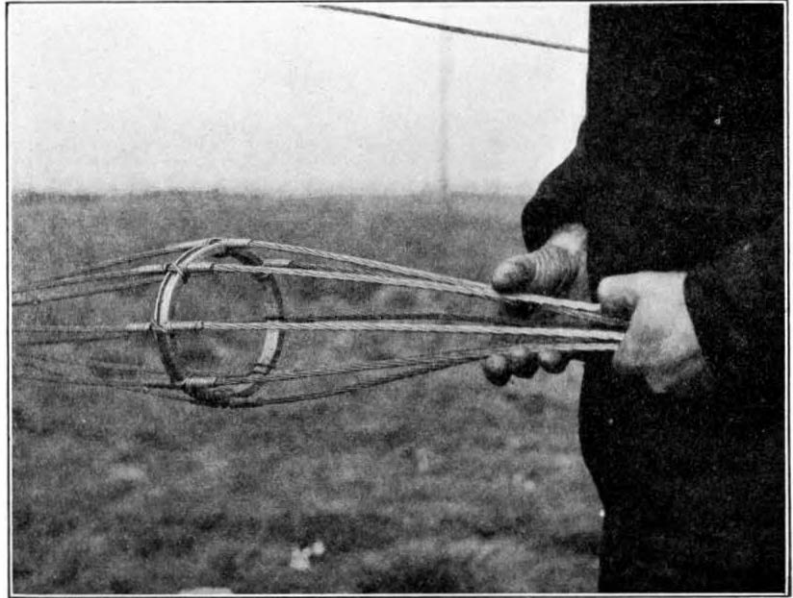

FIG. 5.—CONNECTING TRUNKS BETWEEN THE AERIAL AND THE TRANSMITTER.

ence steel wire rope. In the rebuilding it was decided to dispense with the steel wire rope, to build the lead up on hubless 6-in. diameter bronze spreaders, and to terminate the 7/14 S.W.G. bronze wires on two thimbles in groups of four wires. This method of construction reduces the risk of any of the component wires becoming slack. The connecting trunk is illustrated in Figs. 2 and 5, and Fig. 3 shows the trunk from the lead-out jointed to the end of an aerial span with the triangular coupling plates and shackle ready for attachment to a masthead insulator. The use of copper sleeves for the joints was found to be a neater, quicker and more reliable method than the multiple married joints previously employed and should be particularly useful in facilitating future maintenance work.

It was assumed that each "sausage" would hang in the form of a parabola, having a dip of 70 ft. in a span of approximately one-quarter mile. The actual length of each span varies according to its position, but the slight differences involved are not of such a magnitude as to invalidate the calculation. This parabola is the form assumed by the steel triatic wire and on it, at regular intervals of 124 ft., the spreaders were arranged to lie in planes perpendicular to the parabola. The position in space of the pillars at the spreader arm extremities was calculated, and the individual 7/14 S.W.G. bronze wires were arranged to be in parabolas between these points. The central span of 7/14 S.W.G. bronze wire was allowed a dip which would ensure that it would never contact with the main steel triatic wire if it oscillated laterally under gale conditions. The lengths of adjacent spans of 7/14 S.W.G. bronze wires were then designed so that the resultants of the tensions in the spans on each side of any spreader lay in the plane of the spreader itself, thus balancing the cantilever loads on the arms.

The effects of ice and wind were allowed for, the strength of a spreader being such that it could hold

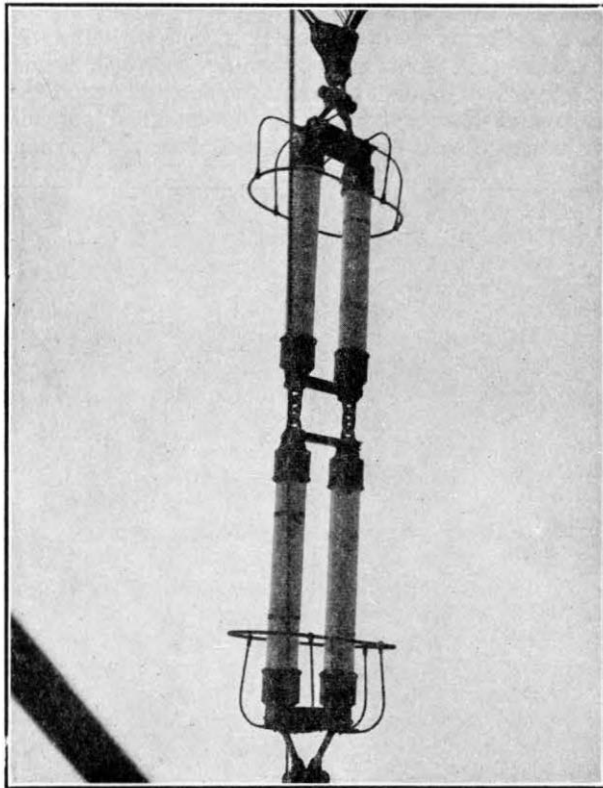

FIG. 4.—AERIAL INSULATORS.

all the wires on one side if all those on the other side were broken in a gale of 100 miles per hour with an ice coating $\frac{3}{8}$ -in. diameter.

Building the New Aerial.

Since the masts are arranged in the form of an irregular octagon, the aerial triatic wires are not all the same length for equal dip and loading on each span. The masts, however, are symmetrical on each side of their north to south centre line. To keep the triatic wires in each span the correct length and at the same time to retain the whole of the aerial in commission between renewal operations with the minimum provision of new triatic wires, two new triatic wires were obtained, and the first spans built on these. The triatic wires recovered were then used for the spans with lengths equal to those from which they were recovered.

The spans were built on the ground in the position from which they were eventually raised. Wooden trestles of sufficient height to allow the spreaders to clear the ground, were let into the earth at intervals equal to the spacing of the spreaders and the triatic wire was laid along the trestles. One end was fastened to an earth screw and the other end was connected to the winding rope of a motor-driven tractor winch (Fig. 6) with a swivel eye between the triatic wire and the winding rope. The triatic wire was then stretched out by the winch, the swivel allowing it to take up its natural "lay," and ensure that the span would not twist when hoisted and was held by the tractor winch in this position while the span was built up. The spreader positions were then measured off and marked by wire binders, and the portion of the triatic wire to be covered by the spreader hub was cleaned and coated with a protective fluid, after which the spreaders were clamped on to the rope. The 7/14 S.W.G. bronze wires which were delivered from the manufacturer in coils of sufficient

length to eliminate joints in the span, were run out, and looped over the spreader binding pillars.

The lengths of 7/14 S.W.G. bronze wires had to be adjusted with great accuracy, to ensure that the "sausage" would hang correctly in its final position. The lengths of the individual wires differ by small fractions of an inch, and to attain the necessary degree of accuracy in measurement thereof and to allow for unavoidable inaccuracies in measurement elsewhere, the individual wire lengths were measured by adjusting the dip in the wire as it hung between pillars on adjacent spreaders.

To terminate the aerial wires at the ends, they were tensioned equally, and each group of four wires on either side of the vertical centre line made off on a thimble which registered with the hole in the triatic thimble. The aerial wires were bound and the wires led out separately ready for jointing. The whole termination was sweated and finally coated with a marine deck varnish. The termination is illustrated in Fig. 3. The triatic wire was finally cleaned and coated with a protective fluid.

Erection of the Aerial.

The masts are provided with electrically-driven winding gear for both the lift cage and the aerial halyard, one driving unit serving both purposes. Separate drums are provided for the lift and aerial halyards and selector gearing allows either to be connected to the power unit. Hand brakes are fitted to each drum and an automatic solenoid brake operates on the electric motor. The connection between the motor control equipment and the power line is by flexible cable and plug and socket connection, which allows the mast to be completely insulated when power is not required. The mast winch is controlled from a position on the mast platform which is about 40 feet from the ground.

The aerial halyard passes from the winch drum up the centre of the mast and through the top platform. On the top platform is a cat head which can rotate in a horizontal plane and supports sheave-wheels over which the aerial halyard passes to the aerial insulators. A swivel eye is provided between the insulators and the halyard.

Each mast is stayed at five places on each of the three sides. One of the line of stays is towards the area enclosed by the octagon and the other two equally spaced behind.

Two 30 H.P. petrol/paraffin tractors, fitted with winches, are available for use at the masts that carry more than one aerial halyard, for lowering and raising the aerial; they also serve to haul the aerial away from the stays when being lowered. The winches are driven from the tractor engine through an hydraulic variable speed gear which provides continuous variation of speed between zero and full speed in either direction. The winch drums are capable

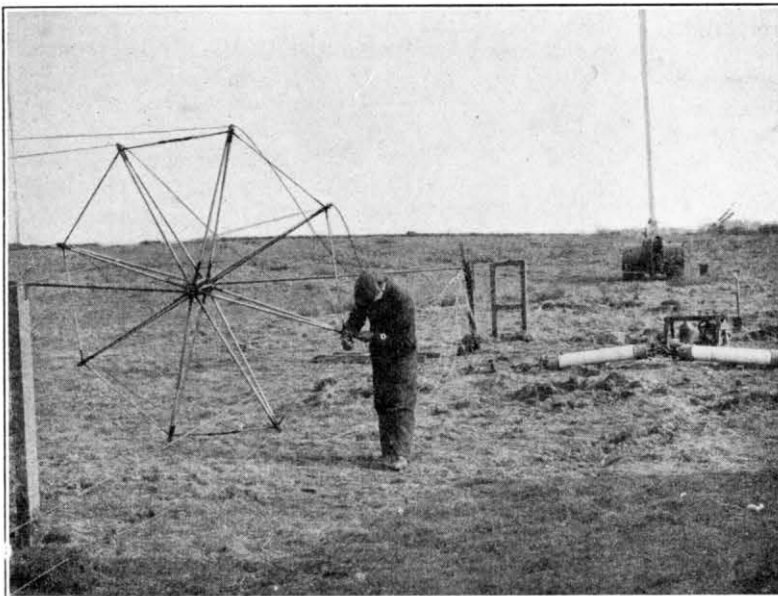

FIG. 6.—A SPAN UNDER CONSTRUCTION.

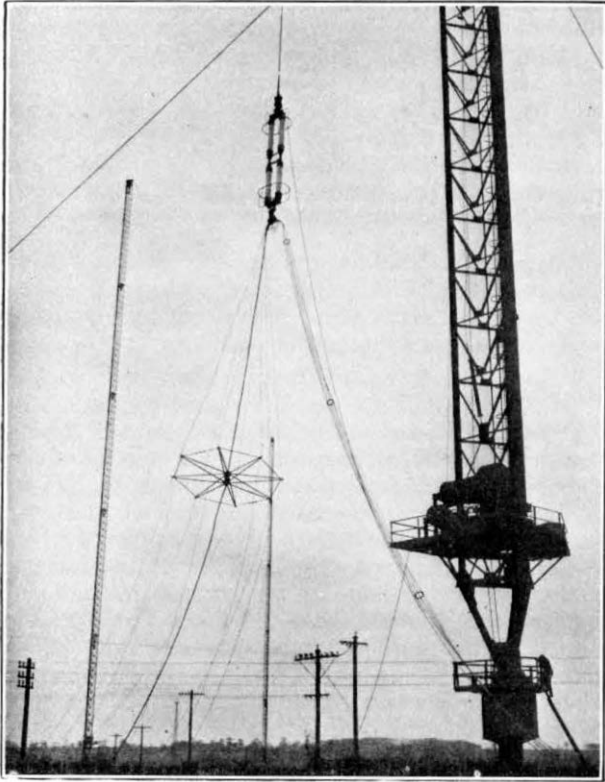

FIG. 9.—NEW SPAN AND LEAD-UP TRUNK BEING RAISED.

By hoisting at mast 4 and maintaining enough tension on the end B by the tractor winch, many of the spreaders of the new span were lifted off the ground. At the spreaders that were not lifted, men were stationed to ease them along, to eliminate damage. When the end B had been manoeuvred to the anchor block C at mast 5 it was anchored to it. The aerial at mast 5 was lowered and the span 5-6 anchored to enable it to be connected to the end of the new span B and jointed, thus completing the continuity of the aerial. The hoisting was then completed, the tractor winches being used where necessary to avoid the aerial touching the stays.

To erect the spans near the building to which the six-inch lead-up trunk was connected, it was necessary to pass the six-inch trunk over the mast stay when the aerial had been hoisted about three-quarters of its full height (see Fig. 8). The operation of passing the six-inch trunk over the stay was done with the two tractors. Both their winch ropes were attached to the end of the six-inch trunk, and while one held it the other was manoeuvred to a position in advance of it towards the final position, and then the second tractor would wind in while the first let out until the second tractor held the six-inch trunk, the first tractor then manoeuvred into a new position nearer the final position, and the operation repeated until the final position was reached, where the

connection to the corresponding six-inch trunk leading to the aerial on the other side and to the lead-in to the transmitter could be made. Fig. 9 shows a new span and lead-up trunk being hoisted into position.

Each span presented its special problem in handling long lengths of a flexible structure under heavy mechanical strains and with a variety of obstructions to circumvent. During the whole of the renewal the weather was poor and on the Sundays selected for the replacement operations adverse winds, rain and bad ground conditions were met. During the operation of passing the six-inch trunk over the stay of number 2 mast the back axle and bearing housing of one of the tractors broke due to the tractor sinking into the soft ground. The result was a hard and anxious day in which all had to pull their hardest to compensate for the broken tractor.

Without the mobile winches (Fig. 10), the work could never have been undertaken in the time. Their ability to manoeuvre into the desired position under their own power and immediately undertake winding without any anchoring made them invaluable.

The work was carried out by the external maintenance staff at Rugby reinforced, when extra man-handling was necessary, by labourers from the internal staff. The programme was arranged for renewal work to occupy alternate Sundays so that in the interval a new span could be built on a recovered triatic wire without undue interference with other external maintenance. Some of the intermediate Sundays were also required to be free for essential painting of upper sections of the 820-ft. masts since some of this work can be done in safety only when the transmitters are not working.

The authors desire to express their indebtedness to Mr. L. L. Hall, who was responsible for the design of the new aerial.

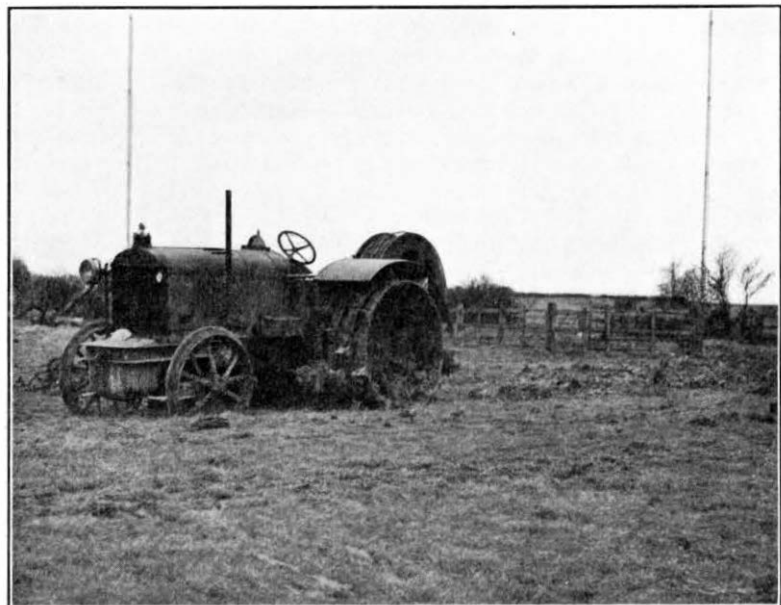

FIG. 10.—TRACTOR WINCH.

Control of Wireless Transmitters and other Electrical Apparatus under the Defence Regulations, 1939

E. F. H. GOULD, B.Sc., A.M.I.E.E.

U.D.C. 654.16.011.1

The article quotes the text of the three Statutory Rules and Orders governing the possession, use and sale or purchase of wireless transmitters and components, and explains the permit system under which such transactions may take place.

Introduction.

UNDER powers granted by the Defence Regulations, 1939, the Postmaster-General, on November 24th, 1939, issued three orders dealing with wireless apparatus. These orders are known as Statutory Rules and Orders, 1939, Nos. 1687, 1688 and 1689, and they are given in full at the end of this article.

It will be seen that under Order No. 1687 no person shall, except with a permit from the Postmaster-General, possess any wireless transmitter, wireless apparatus components capable of being assembled to form a wireless transmitter, or a wireless receiver designed to be used also as a wireless transmitter or which can readily be adapted for the purpose.

At the outbreak of war, with few exceptions, all wireless experimental licences were cancelled and under the conditions of the licences the apparatus was taken into custody by the Post Office. The Post Office, however, had no power to take action against the owners of wireless transmitters which were unlicensed unless these were wireless telegraph transmitters (which term includes wireless telephone transmitters) and were installed. The order, therefore, is much more stringent than the Acts, as it applies to any type of transmitter, and applies whether the transmitter is installed or not. The order was made on the 24th November, 1939, but did not come into effect until December 15th in order to provide an interval in which persons in possession of transmitters could divest themselves of the same or obtain permits for their retention.

Order No. 1688 makes it an offence for any person, except under a licence or permit granted by the Postmaster-General, to use a wireless transmitter. The effect of this order is to bring under control all types of wireless transmitters and to make unlawful use subject to higher penalties than are prescribed by the Wireless Telegraphy Acts.

Order No. 1689 prohibits without a permit the disposal or acquisition of wireless transmitters and certain other electrical apparatus. This other apparatus includes certain parts of wireless transmitters, high frequency equipment and electronic valves capable of an anode dissipation exceeding 10 W.

This order does not apply to Government Departments, but it applies to firms supplying Government Departments; and in order to avoid any impediment of such contracts, the leading contractors were issued with continuing permits authorising them to supply controlled articles to Government Departments. Steps were also taken to issue general permits to sub-contractors of contractors to Government

Departments. In order to avoid any delay or interruption in the work of dealing with applications, the necessary staff were evacuated to Harrogate before the coming into effect of the orders.

The Permit System.

Although it is essential that a complete control of the articles named in the order should be maintained, it is desirable that legitimate trade should experience as little interference as possible. In some classes of transactions it has been found possible, without defeating the objectives of the order, to issue a continuing permit provided that suitable records are kept of the transfer of controlled articles from one concern to another. These records are kept by the recipients of the continuing permits, and they must be open to inspection at any time by an authorised representative of the Postmaster-General.

For example, it is quite a usual thing for the sound-reproducing equipment in cinemas to be supplied on a maintenance service contract and for service engineers to inspect the apparatus at regular intervals and replace any valves which are faulty. The great majority of these valves come within the scope of the order and a permit would be necessary for this replacement. As the replacement of a valve has to be recorded and the old valve taken away, the Postmaster-General has issued continuing permits to the firms who are engaged in the business of maintaining the cinema equipment, for the supply of valves as replacements, provided their records are open to inspection. Continuing permits have also been issued to the owners of those cinemas where the installation is maintained in this manner authorising them to receive the replacement valves. On the other hand those cinema owners who maintain their own equipment have to obtain a permit before purchasing any replacement valve controlled by the order.

As one might expect, by far the largest number of permits applied for are in connection with valves. The wording of the clause in the order, dealing with valves, is as follows: "electronic valves capable of an anode dissipation exceeding 10 W." For the present it has been decided that, with few exceptions, the makers' advertised characteristic and anode rating will be taken as a guide in deciding whether or not the valve is capable of an anode dissipation exceeding 10 W. A notable exception is that all transmitting valves are included in the controlled list although a few have declared ratings of less than 10 W. This is because it is known that, although their useful life will be shortened if operated under such conditions, they are capable of an anode dissipation in excess of 10 W.

A fairly complete list of the valves which at the present time are subject to control is given in Tables 1, 2 and 3. From these it will be seen that many of the types commonly employed in domestic radio receivers are included. The number of transactions in new and second-hand radio sets and replacement valves in which controlled valves are involved is probably of the order of 200,000 per annum, which gives some idea of the magnitude of the work involved in maintaining control.

To facilitate the distribution of wireless receiving sets, continuing permits for the sale and purchase of valves with an anode dissipation exceeding 10 W but not exceeding 25 W are being issued to valve makers, set makers and valve wholesalers. The conditions of issue of these permits are similar to those which apply to continuous permits for cinemas. This scheme will soon be extended to approved radio retailers, but a separate permit will continue to be necessary for transactions between retailers and the members of the public in which controlled articles are involved.

When a permit is issued authorising the purchase of a controlled article it is essential, for the completion of the transaction, that a permit authorising the sale should at the same time be issued to the supplier. The form of application for a permit is T.99.G, a reduced reproduction of which is shown in Fig. 1. If the permit is authorised, Part A is retained, Part B is sent to the purchaser and Part C to the vendor. All three parts of the form must be completed before the form is submitted, and failure to do this or other common omissions, such as not stating the number and type of valves, leads to delay in the issue of the permit. Extensive modifications to this form are at present under consideration to reduce the liability to such errors and also to reduce the clerical work in dealing with the applications.

Orders 1687, 1688 and 1689 apply to Great Britain and Northern Ireland and, with certain minor differences, similar orders cover the Channel Islands and the Isle of Man. Firms outside these places are not bound by the order, but their customers or suppliers in the places named must have a permit to purchase and sell respectively. The permits issued by the Postmaster-General are additional to any other licences which are necessary to comply with the orders of other Government Departments, e.g., export licences required by the orders of the Board of Trade.

STATUTORY RULES AND ORDERS 1939

No. 1687

The Postmaster General in the exercise of the powers conferred on him by Regulation 8 of the Defence Regulations, 1939, hereby orders that on and after the 15th day of December, 1939, no person shall, except under the authority of a written permit granted by the Postmaster General for the purpose, have in his possession or under his control (1) any wireless transmitter which is designed to be used for communicating by wireless telegraphy, wireless telephony or wireless television; or as a navigational beacon or landing beacon or otherwise for the purpose of indicating position or direction; or for the purpose

of the remote control of machinery, or (2) wireless apparatus components capable of being assembled to form such a wireless transmitter, or (3) any wireless receiving apparatus which is designed to be used also as a wireless transmitter or which can be adapted for the purpose of being used as a wireless transmitter by the operation of a switch or by the changing of screwed or plug connections.

This order shall not apply in relation to any apparatus in respect of which there is in force a licence under the Wireless Telegraphy Acts, 1904 to 1926, authorising the use of the apparatus for transmission.

Applications for permits should be made to the Engineer-in-Chief of the Post Office, stating full particulars of the apparatus or article concerned, the purpose for which it is required, and the name, address and occupation of the person or company in whose possession or under whose control the apparatus or article is to be retained.

Dated this 24th day of November 1939.

G. C. Tryon.

No. 1688

The Postmaster General in the exercise of the powers conferred on him by Regulation 8 of the Defence Regulations 1939, hereby orders that on and after the 25th day of November, 1939, no person shall, except under a licence or permit granted by the Postmaster General, use a wireless transmitter for communicating by wireless telegraphy, wireless telephony or wireless television; or as a navigational beacon or landing beacon or otherwise for the purpose of indicating position or direction; or for the purpose of the remote control of machinery.

This order shall not apply in relation to any apparatus used in accordance with the terms of a licence in force under the Wireless Telegraphy Acts 1904 to 1926 authorising the use of the apparatus for transmission.

Applications for licences or permits should be made to the Engineer-in-Chief of the Post Office, stating full particulars of the apparatus concerned, the purpose for which it is to be used and the name, address and occupation of the person or company who wishes to use it.

Dated this 24th day of November 1939.

G. C. Tryon.

No. 1689

The Postmaster General in the exercise of the powers conferred on him by Regulation 55 of the Defence Regulations, 1939, hereby orders that on and after the 25th day of November, 1939, no person shall, except under the authority of a permit granted by the Postmaster General for the purpose, sell, purchase, let, hire, supply, dispose of, acquire or distribute any of the under-mentioned articles:

- (a) Wireless transmitters which are designed to be used or are capable of being used for communicating by wireless telegraphy, wireless telephony or wireless television; or as navigational beacons, or landing beacons, or otherwise for the purpose of indicating position or direction; or for the purpose of the remote control of machinery.

For Official Use
Only

Reference No. **W.**

Checked by.....Date

For Official Use
Only

Reference No. **W.**

This number must be quoted to the supplier before delivery of the apparatus can be taken.

Valid for one month from date of issue

Application on behalf of a firm must be made by a responsible individual member of the firm.

Sufficient detail must be given to identify the apparatus.

If required for replacement, this should be stated. If a licence or permit is already held covering the possession or use of wireless transmitting apparatus, this fact should also be stated.

Authority will only be given to obtain from a specific supplier.

PART A (To be filled in by applicant).

1. Full name of applicant **T. Atkins,**
Address **1, Britannia Parade,**
Ploughgate.

2. Nationality **British.**

3. Age (if under 21) **Over.**

4. Description of apparatus to be obtained :—
2-KT 33C Osram Valves.

5. Purpose for which apparatus is required :—
Replacement in Domestic
Radio Set.
“ Stray ” Radiogram Model. N.B.

6. Address at which apparatus will be housed and used :—
1, Britannia Parade,
Ploughgate.

7. Full name or title of supplier
Marianne Radio Ltd.,
Address of supplier **2, Main Street,**
Ploughgate.

Signature of Applicant :—

Tommy Atkins

Date :—
25th day of **January** 19 **40**

PERMIT TO OBTAIN CONTROLLED ELECTRICAL APPARATUS
(Not valid until authorized by Engineer-in-Chief, Radio Branch, G.P.O.)

PART B (To be filled in by applicant)

To agree with
PART A (1).

1. Name of applicant **T. Atkins,**
Address **1, Britannia Parade,**
Ploughgate.

To agree with
PART A (4).

2. Description of apparatus :—
2-KT 33 C Osram Valves.

To agree with
PART A (7).

3. Name of supplier **Marianne Radio Ltd.**
Address **2, Main Street,**
Ploughgate.

For Official Use
Only

Reference No. **W.**

This number must be quoted by the applicant before the apparatus may be handed over to him.

Valid for one month from date of issue

PERMIT TO SUPPLY CONTROLLED ELECTRICAL APPARATUS
(Not valid until authorized by Engineer-in-Chief, Radio Branch, G.P.O.)

PART C (To be filled in by applicant)

To agree with
PART A (7).

1. Name of supplier **Marianne Radio Ltd.**
Address **2, Main Street,**
Ploughgate.

To agree with
PART A (4).

2. Description of apparatus :—
2-KT 33C Osram Valves.

To agree with
PART A (1).

3. Name of applicant **T. Atkins,**
Address **1, Britannia Parade,**
Ploughgate.

FIG. 1.—APPLICATION FORM FOR PERMIT.

- (b) The following articles intended for use as parts of wireless transmitters, namely: high frequency inductors, spark coils, quenched and rotary spark gaps.
- (c) Any wireless receiving apparatus which is designed to be used also as a wireless transmitter or which can be adapted for the purpose of being used as a wireless transmitter by the operation of a switch or by the changing of screwed or plug connections.
- (d) Line carrier telegraph equipment or line carrier telephone equipment.
- (e) High frequency equipment (being equipment which generates or uses high frequency current at frequencies greater than 10,000 cycles per second and having a maximum output exceeding 10 watts), including such equipment intended for use in connection with furnaces and medical apparatus.

- (f) Electronic valves capable of an anode dissipation exceeding 10 watts.
- (g) Piezo electric quartz plates or piezo electric tourmaline plates cut to oscillate at any specified frequency.

Applications for permits should be made to the Engineer-in-Chief of the Post Office, on forms obtainable at any Head Post Office or from the Engineer-in-Chief, stating full particulars of the article concerned, the purpose for which it is required and the name, address and occupation of the person or company who wishes to obtain it and of the person or company from whom it would be obtained.

Dated this 24th day of November 1939.

G. C. Tryon.

TABLE 1

RECEIVING AND POWER AMPLIFIER VALVES OTHER THAN AMERICAN TYPES

Note.—Valves similar to the following but incorporating diodes fall into the same classes

MAKER'S NAME	RATED ANODE DISSIPATION	
	Over 10 watts and up to and including 25 watts	Over 25 watts
B.T.H.	—	TV250, TV845, V503
COSSOR	2XP, 4XP, 42SPT, PT41B	420XP, 440XP
DARIO	TL54, TD24, TF104, TF364	—
EDISWAN.. .. .	—	ES60, ES75, ES75H, ES75X, ES100, ES250M
EKCO	OP41	—
EUROPA	AC/PX4, AC/PX15	AC/PTE, AC/PX25, AC/PX25A
EVER READY	S30C, S30D, A70E	—
FERRANTI	P4, LP4	—
HIVAC	PX5, PX41	—
MARCONI OSRAM	KT33, KT33C, KT44, KT66, PT16, PT25, PT25H, PX4, PX25, PX25A, LS5a, LS5b, B63, B30, BL62	DA30, DA41, DA60, DA100, DA250, DEM2, DEM3
MAZDA	PA20, PP3/250, PP5/400, AC4/Pen, AC6/Pen, Pen 44, Pen 46, PP3521	PA40
MULLARD	AC042, AC044, D020, D024, D025, D026, PM24B, PM24C, PM24D, PM24E, PenB4, Pen 428, Pen 650, EL6, EL50, AC084N	D030, D040A, MZ05-60, MZ05-20, MZ1-70, MZ1-75, MZ1-76, MZ1-100, MZ2-200, MZ2-250, MX4-400
PHILIPS	F443N, EL50, 4641, 4683, E406N, E408N, 4688	E707, 4642 (MC1/60), 4643, MC2/200, MC1/50
RECORD	AC/PX4, AC/PX15, AC/PTE	AC/PX25, AC/PX25A
TRIOTRON	P469, K480, K435/10	—
TUNGSRAM	P-12/250, P-15/250, EL5, EL6, APP4E, O-15/400, OS-18/600, P-25/450, P-25/500, P-26/500, P-27/500, P-28/500	P-30/500, OP-37/600, OP-38/600, P-40/800, P-41/800, O-40/1000, P-60/500, OP-70/1000, O-75/1000, P-101/1000, P-100/1250, OQQ-150/3000, O-240/2000, O-250/2000

TABLE 2
AMERICAN TYPE VALVES, BRITISH AND IMPORTED

RATED ANODE DISSIPATION	
Over 10 watts and up to and including 25 watts	Over 25 watts
2A3, 6A3, 6A5G, 6A6, 6B4G, 6B5, 6L6, 6N6G, 6N7, 6V6, 7C5, 46, 50, 53, 59, 79, 250, 2151. <i>Note.</i> —Valves having coding similar to the above but with additional suffixes, e.g., E, EG, G, GT, also fall into this class.	845, 842, 841, 807, 35T, 825, 300A, RK31, 756, RK20, RK46, 203B, 830B, 203Z, ZB120, WE242A, WE284D, 203A, 838, 852, RK38, 211, 805, HD203A, 150T, HK354, 822, 250TH, WE212E, 300T, 849, 500T

TABLE 3
GAS-FILLED TRIODES AND RECTIFIERS

Maker	Gas-filled Valves	Rectifiers
B.T.H.	—	U. 150/1100
COSSOR	—	405BU, 225DU
EDISWAN	M.R.75, M.R.300	MU1, EHT10, EHT15, ESU75, ESU150, ESU150X, ESU204, ESU206, ESU300, ESU400, ESU450, ESU1500, V1901
MARCONI OSRAM	G.T.5E, G.T.25E	GU1, GU5, U17, MR1, MR2, MR4, MR6, MR7A, MR9, MR10, U2A, U6, U15, CAR2, CAR4, CAR6, GU2, GU7, GU8, GU20, GU21, GU9, GU50
MAZDA	—	UD41
MULLARD	—	RG1-125, RG1-240, RG1-250, RG2-1000, RG3-250, RG3-1250, RZ1-150, RZ1-250, RV2-125, RX3-120, RX8-50, RX10-80, RX10-200, RG5-500, RG5-1500, RG5-6000, RG10-1500
PHILIPS	—	4649, 4646, DC1/50, 4647 (DC1/60), 4648 (DC2/200)
STANDARD TELEPHONES AND CABLES	—	4059-A, 4007A, 4008-B, 4222-A, 4017B, 4049C, 4064A, 4064B, 4077A, 4078A, 4079A, 4080A
TUNGSRAM	—	PV-75/1000, PV-100/2000, RG250/1000, RG250/3000, RG1000/3000, V21/7000

Storm Damage, January, 1940

U.D.C. 621.315.1.056.5

The following account of the damage caused to Post Office plant by the severe snow and ice conditions experienced in the South of England at the end of January, has been compiled from notes sent in by the Regions principally concerned.

Introduction.

ALTHOUGH the O.E.D. does not sanction the use of the word storm to describe the somewhat unusual weather experienced in the Southern Counties on the afternoon and night of January 28th, some license can assuredly be granted to those whose interests in bad weather centre on consequences rather than on cause or degree; and when damage caused by bad weather has to be made good under a strict accounting system with strict accounting nomenclature, there might be no alternative but to disregard the O.E.D. Measured solely by its effect on Post Office plant, the January storm, as presumably it will have to be called, was the worst ever experienced in the South of England.

Towards the end of January, after several weeks of bitterly cold weather, the temperature had fallen to nearly 30 deg. F below freezing point, and stretches of the Thames were completely frozen over. On the night of Saturday, January 27th, the roads were glazed over by a frost following rain, but late in the morning of the 28th the ice melted in some coastal areas and there was a thin mist, probably caused by the meeting of moist air driven up from the Channel with colder air over the land. In the early afternoon the temperature dropped again, and it could be seen that the surfaces of leaves, branches, and so forth, were taking on a thin coating of ice. Raindrops from spasmodic showers of fine rain froze as they touched solid things, and cold metallic surfaces were



FIG. 1.—A TYPICAL ICE-COATED WIRE, WORCESTER.

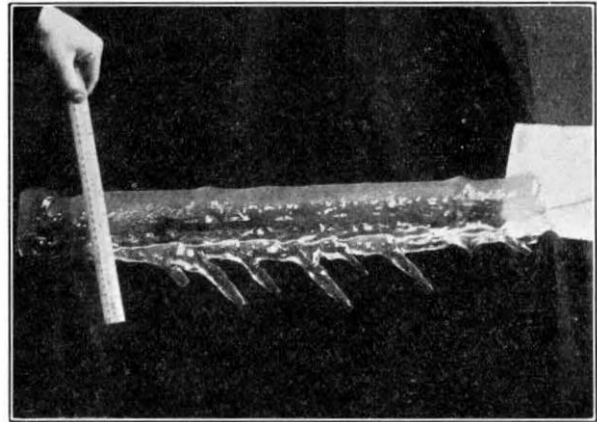

FIG. 2.—AN ICE-COATED WIRE PHOTOGRAPHED AT BRISTOL.

rapidly coated with ice. There was a marked temperature gradient during the afternoon and the glazing had the appearance of slowly settling down from the tree tops. There was practically no wind, but by the following morning many wires and poles were down under weight of ice alone. In some districts on that Sunday evening a heavy snowfall commenced and continued until many roads were impassable, while transport, both rail and road, became excessively difficult, and in some areas impossible. The load of snow on overhead plant already ice-covered imposed a strain so abnormal that poles snapped; stout, well-constructed routes simply collapsed, at times causing serious road obstruction.

Although the primary trouble was failure of plant under severe ice loading, considerable damage was caused by falling branches. The trees with wide spreading branches were most hit, and for once the oak was more troublesome than the elm. Trees along water courses suffered severely. The greater part of the damage to line plant showed up on the night of the 28th and the morning of the 29th, but the ice loading did not materially change for three days and much of the damage caused by falling branches occurred as the thaw set in.

On January 31st a thaw commenced and the snow melted rapidly, again exposing the ice underneath. Serious flooding of low-lying roads and excessively slippery conditions followed, together with considerable fog in some parts, while the relaxation of ice coatings resulted in many more falling branches. One telephone exchange of about 90 subscribers was flooded to a depth of between 2 and 3 ft.

Home Counties Region.

The interruptions to service in the Home Counties Region included 110 exchanges isolated, 1,200 trunks, junctions, and private wires, and 33,000 subscribers' circuits, out of order. The damage to plant may be



FIG. 3.—DEFLECTED POLES AT CYNCOED, CARDIFF.

put at 600 poles down and broken, 8,000 poles deflected, 150,000 span-wire breaks, 15 aerial cables broken down, and hundreds of thousands of wires pulled through binders or stretched beyond the material's elastic limit. These figures give some idea of the damage, but it would be as well to mention that the lesson learnt in this storm that stands out beyond all others is that bare figures of this sort lose their significance, and can be misleading, if due allowance is not made for the extent to which plant is spread. Forty wires down in 10 consecutive spans present a different problem from 4 wires down in 100 spans scattered over a truly rural area, and the clearance of a fault caused by wires down in one span is a different proposition from the clearance of one fault due to wires down in 50 spans. The damage was widespread and localised only to the extent of its being most severe on high ground where the temperature was lowest. The higher land on Salisbury Plain was the black spot, if this region can be called a spot without fear of misleading any one as to its size.

The work of clearing the roads—in these times a matter of even greater importance than usual—was commenced on the 29th, and the whole engineering staff, with the exception of certain exchange and repeater station maintenance men and a handful of men on urgent fitting work, was mobilised for surveys of damage and for the control and execution of repairs. Gangs were strengthened by men drawn from the nearest army depots, and additional gangs from other regions less seriously affected have been coming in from time to time. The first completely equipped foreign gang arrived on February 4th; 22 additional gangs have arrived at the time of writing, and others have been promised. The organisation devised for storm repairs has shown up in excellent light, and it would be difficult to level any constructive criticism against it.

It was not until February 8th that all the isolated exchanges were given an outlet—even then at least four of them had only the exchange kiosk working—

and service restored on all, or on practically all, of the P.W. and E.C. circuits. A contributory cause to the delay in effecting temporary restoration of essential services is to be found in the fact that practically every pole in some areas was coated with ice up to 3 ins. in thickness for three clear working days.

As might be expected, the supply companies were badly hit in rural areas. The grid of the C.E.B., the H.T. distribution lines of the Area Distribution Companies, and the L.T. lines of the local companies were all affected by broken line conductors, by iced-up insulators and ice-clad switches. The power supplies in one area of roughly 900 square miles served by some 60 rural exchanges were disconnected for periods of from 2-14 days. Service in the greater part of this area was restored by the end

of the third day, but, even so, some anxious moments were experienced. It was particularly fortunate that there was a large percentage of manual exchanges—the two most important military areas are served by magneto exchanges and primary

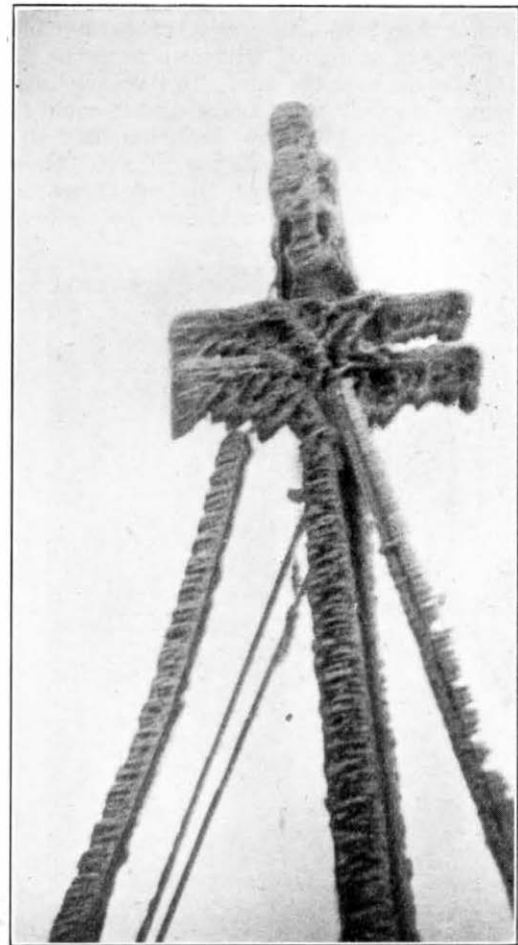

FIG. 4.—POLE HEAD ENCASED IN ICE.

batteries—and a good percentage of auto exchanges with petrol engine charging sets. It was an additional relief to know that there were no P.B.X.'s served by the new power float system. One 6 kW set—one amplifier station was involved—one 3 kW set, and one 1 kW set, sufficed to keep things going.

Some detailed observations on damage and on degree of ice loading may be of interest. In regard to ice loading: the accumulated ice took many forms from concentric to elliptical with the conductor near the upper edge, to, in one case at least, a wall of ice built up on the upper surface of the conductor. Measurements of typical elliptical forms gave an ice circumference of as much as 7½ in. with 4-in. icicles at intervals along the mass. Aerial cables, suspension wires and rings were iced into a solid block; one pole top comprising six eight-way arms was a solid block of ice, arms, spindles and insulators being enclosed, and the doors at a number of U.A.X.'s were sheeted with a thick layer of ice.

Midland Region.

In common with many other areas, the snowstorm during the last week-end in January caused serious dislocation to services, particularly in the Birmingham Telephone Area. This was reminiscent of the great blizzard that occurred during the last war—in March, 1916—and the depleted staffing resources arising out of the war made it a somewhat comparable matter. Then, snow and wind, heavy and strong enough to uproot whole pole routes; now, snow and ice, but happily very little wind excepting in the Bridgnorth corner of the area.

The snowfall, probably the heaviest in this part of the country in living memory, coming during the greatest frost in nearly 50 years, rendered many roads both in town and rural districts entirely impassable

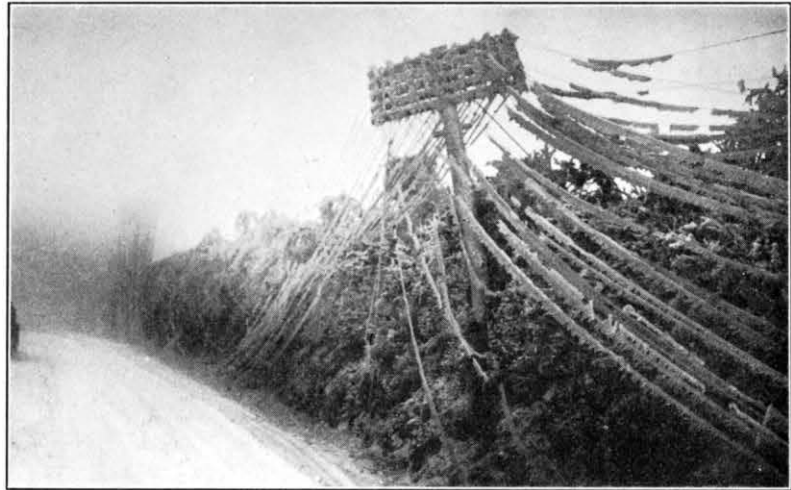

FIG. 6.—TYPICAL SECTION OF THE EXFORD-SIMONSBATH ROUTE.

to transport, and therefore seriously impeded the repair operations. These conditions continued until the following week-end, when they were eased slightly by a slow thaw lasting for two days only, when a return of the Arctic conditions occurred.

Despite these conditions, however, over 11,000 faults on subscribers' circuits were cleared within fourteen days, and service restored to 35 out of the 38 exchanges—mainly U.A.X.'s in the more exposed portions of the area—that had been completely isolated by the storm.

Some interesting exhibits of the storm were many single wires found in the Worcester and Evesham Control Areas, neatly centred in a covering of ice 8½ in. in diameter, weighing 3 lb. to the foot.

As these ice-bound conditions continued for a week after the snowfall, and in some areas trees and thick branches brought down by weight of snow and ice were strewn across roads and the Department's routes, some idea can be obtained of the difficulties that had to be contended with by the staff in their efforts during this period to effect repairs.

Of a total of 145,000 stations in the area, the maximum numbers of subscribers' lines and junctions out of service at any one period were approximately 6,200 and 275 respectively. The number of poles broken amounted to 170 and over 2,000 were deflected. Approximately 2,300 miles of wire were brought down and 4,000 miles required re-regulating.

In an area in which the fault rate had been consistently declining month by month, until in the month prior to the storm it fell to the record low level of 1.19, the publication of the subsequent statistics is not being looked for with the same pleasurable anticipation as hitherto. A consoling reflection in the previous fault figures is that but for earlier efforts the storm results might have been far worse.

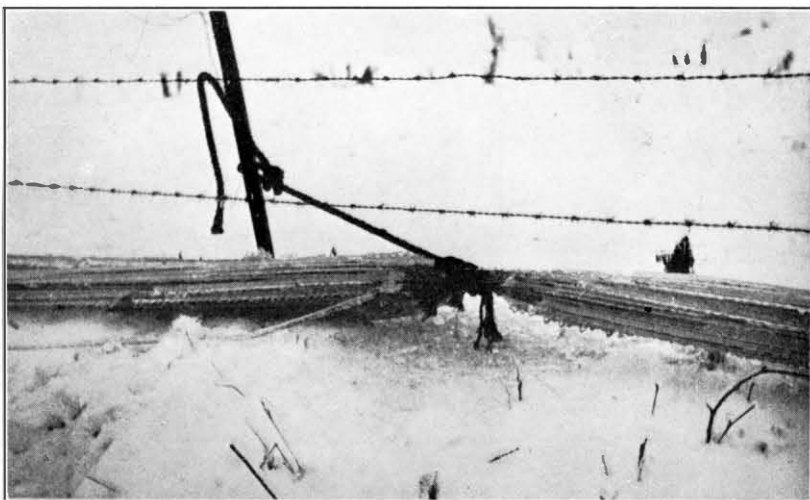

FIG. 5.—FALLEN WIRES FROZEN IN SOLID MASS ON THE OXFORD-WANTAGE ROUTE.



FIG. 7.—DAMAGE IN THE BRISTOL AREA.

South-Western Region.

The freak weather conditions experienced in January resulted in very severe damage to overhead plant in the South Western Region. Altogether more than 10,000 subscribers' circuits and 1,000 trunks and junctions were affected, and 109 exchanges isolated following the night of January 28th, 1940. The damage to plant involved 10,000 poles deflected, 700 broken poles, the re-erection of 6,000 miles of wire and the re-regulation of wire at more than 200,000 insulating points. The estimated total man-hours exceeded 400,000 and more than 50 per cent. of the damage occurred in the Bristol Telephone Area, in which 50 exchanges were isolated and more than 5,000 subscribers' circuits put out of order.

A feature of this storm was that the routes on high ground were mainly affected, thus in the South-Western Region the damage was most severe on routes crossing the Mendips, Exmoor, Dartmoor and other high ground in Somerset, Devon and Dorset. Practically no damage occurred west of the Tamar Valley. In some instances the extent of the damage was almost proportional to the height above sea level—this was particularly noticeable on routes crossing Exmoor.

An interesting feature was the manner in which aerial cable routes withstood the damage, although in the same localities open wire routes were completely wrecked. In normal conditions the stresses due to an aerial cable are equivalent to a considerable number of wires, but under conditions of ice loading the

aerial cable provides only one gathering surface and the increase in stress is, therefore, much less rapid than with open wires.

It was noticed that in many of the pole breakages the pole collapsed under torsion and did not fracture cleanly. The maximum torsion appeared to be at a point about 2 ft. from ground level.

Repair work was rendered extremely difficult immediately following the damage, as the majority of the roads were almost impassable for some days. Poles were so coated with ice that they were dangerous to climb and the general conditions rendered even preliminary clearing a protracted and dangerous operation. The extent of the damage necessitated the withdrawal of all gangs from normal construction work for some weeks and the recruitment of additional staff and in addition valuable assistance was rendered by the

military authorities. The existence of the control organisation set up in connection with the defence communications and repair of air-raid damage considerably facilitated control of the repair work, so that service was restored to all exchanges in the South-Western Region by February 16th, 1940. A severe snowstorm occurring on February 16th, however, undid much of the repair work already done, 39 exchanges being isolated, and the general repair work was considerably delayed in consequence.

It is anticipated that by the time this article is published the bulk of the repairs will have been completed.

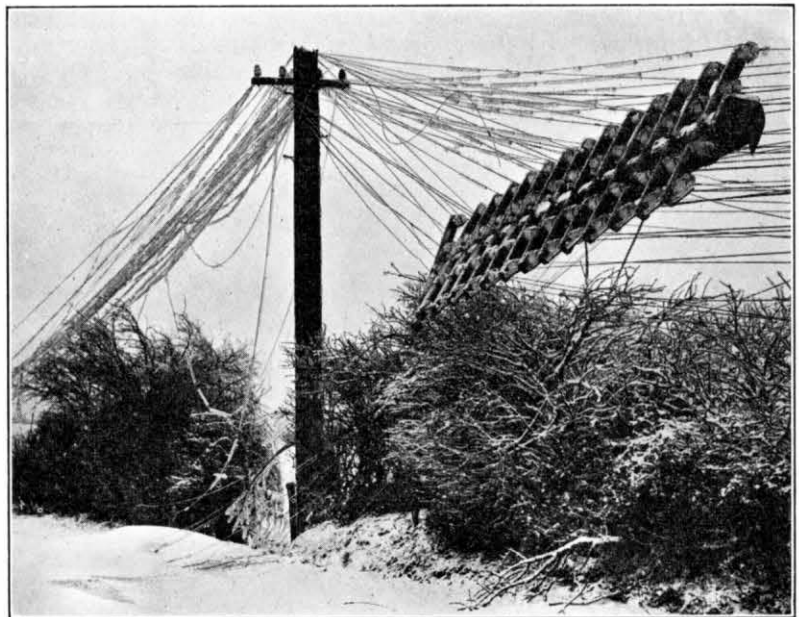

FIG. 8.—BROKEN POLE "SOMEWHERE IN SOMERSET."

Welsh and Border Counties Region.

In the Welsh and Border Counties Region many pole arms, combiners and insulators were encased in ice ; poles collapsed under the strain, and fallen wires were frozen fast to the road surface. 190 exchanges were isolated and 1,300 trunk and junction circuits and 17,000 subscribers' circuits affected ; 1,500 poles were broken and at least 15,000 deflected ; failure of the power supply due to breakdown of overhead power lines contributed to the isolation of some exchanges and use had to be made of emergency charging apparatus.

For several days after the breakdown the persistence of ice on poles and wires and continued damage to plant through branches of trees collapsing under the weight of ice made it impracticable to do much work other than clearing obstructions. Wires cut down could not be coiled up as the ice could not be removed. Adverse transport difficulties were encountered and many roads were impassable owing to deep snow drifts so frozen on the surface that the crust could not be broken, indeed some isolated exchanges could not be approached by car or van at a closer distance than ten miles. Some idea of the severity of the weather may be gleaned from the fact that birds were frozen to death in the trees, and animals found completely encased in ice.

Until the ice accumulation had begun to be dispersed by the thaw, a condition which did not arrive for about ten days after the storm, the efforts of the staff were severely handicapped in spite of all kinds of temporary expedients to remove low insulation due to ice formation on the pole insulators such as the use of fire pots and braziers. Again when the thaw did occur it was found that deflected poles which hitherto could not be attended to owing to the frozen nature of the ground collapsed as the ground became softer, thus contributing to the damage. A further unusual feature illustrating the difficulties met with in the early stages of restoration was that at altitudes of 600 ft. and upwards, of which there



FIG. 9.—THE SHREWSBURY ROAD LINE NEAR CHIPPING NORTON.

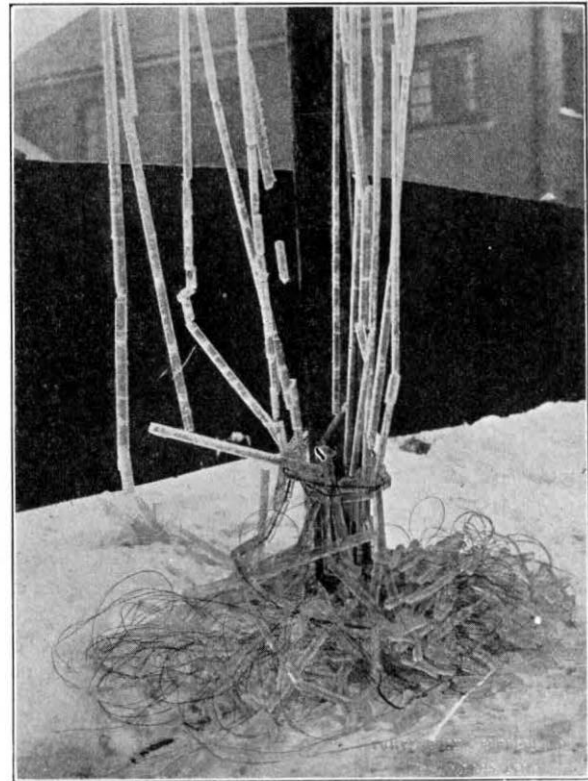

FIG. 10.—ICE-COATED WIRES AT PORTSDOWN HILL, SOUTHAMPTON AREA.

are many in this region, low-lying clouds continued to cause further ice accumulation on wires temporarily repaired so that they were again put out of action.

The whole of the available resources of the Region were mobilised to restore service ; assistance was obtained from other Regions ; casual labour was engaged ; and, by courtesy of the military authorities, timely assistance was given by troops. All possible means were adopted to give temporary service.

Interruption cable, aerial cable and one-pair braided cable were extensively used, and circuits were transferred to alternative routes or new cables were drawn into existing ducts to obviate permanent restoration of overhead routes scheduled for diversion. A further measure adopted in special cases to expedite temporary service to distant subscribers was to group them on a party line basis.

Tribute to the Staff.

It is desired to place on record an appreciation of the devotion to duty and resource displayed by the staff under most discouraging weather conditions.



FIG. 11.—FALLEN WIRES ON THE SOUTHAMPTON-WINCHESTER ROUTE.

Many acts deserving of commendation have been reported, and it is true to state that, without exception, every member of the staff employed on the restoration work showed more than ordinary initiative in coping with the many difficulties that continually arose. Thanks are also due to the military for their unstinted help, weekdays and Sunday alike, which went a long way to meeting the problem of staff shortage.

Illustrations.

Acknowledgement is due to the *Bristol Evening*

World; Southern Newspapers, Ltd.; *Bath and Wiltshire Chronicle*; Portsmouth and Sunderland Newspapers, Ltd.; Frank Packer, Chipping Norton; R. Kingsley Tayler, Minehead; and A. D. McQuirk, Worcester, for permission to publish some of the photographs in this article.

Thanks are also tendered to the many Post Office officers who sent in these and the other photographs published, as well as the very large number which space limitations preclude us from publishing.

Recent Changes to Equipment on Test Desks

Face Equipment.

To meet the increase in the type and character of the circuits used under present-day conditions in automatic telephone exchanges, it has been necessary to increase the number of testing circuits to the test desk, and modify existing testing facilities. To do this has necessitated a revised lay-out of the face equipment of a modern test desk in order that the maximum efficiency shall be obtained by the test clerk in dealing with the many and varied classes of circuits he is now called upon to control.

It was considered whether it would be advisable to supersede the test desk by a trunk test rack, thereby obtaining more panel space. However, after due consideration it was decided to retain the test desk, other than, of course, in trunk exchanges and rather small exchanges.

In arranging the new lay-out care has been taken to ensure that all circuits of similar type are kept together. For example all the incoming lines (E.N.G. Faultmen, Automatic and Manual Board, etc.) appear in panel 3 of the testing section, and all outgoing lines are provided in the miscellaneous panel.

The provision of 30 lines to Test Selector in panel 1 of the testing section presented some difficulty as the circuit employed "lever" type keys which occupied 2 in. of vertical panel space; it was arranged, however, for the Private Control keys to be of the "plunger" type which requires only $\frac{1}{2}$ in. space.

The revised lay-out cannot, of course, be applied to existing desks but it will be used for new suites, and it is thought that its application will facilitate the work of all using the test desks.

Rear Equipment.

At present each contractor works to his own particular lay-out and steps are being taken to standardise the wiring and lay-out. Several new wiring and cabling features are being incorporated, for example, to facilitate cabling the test bell lamps on the M.D.F., all the test bell circuit leads are being concentrated on a connection strip situated in the first test desk position in the suite, and from there one multiple cable (switchboard or lead-covered) will be run to the lamp box.

J. A. C.

A New Subscribers' Intercommunicating Table Telephone Set

L. W. ELLEN and
S. C. GORDON

U.D.C. 621.395.331

The authors describe a new bell set and associated telephone which give intercommunication facilities between a main station and one or two extension instruments. The new telephone has several marked advantages over previous equipment of this type.

Introduction.

ONE of the most popular extension telephone arrangements is that known officially as "Plan No. 7" whereby two telephones, "main" and "extension," can use an exchange line, either with or without secrecy against each other, and can also intercommunicate, with the exchange line held or free, as required. From the year 1925 until recently the necessary switching conditions at the main station for such an installation were obtained by the use of a Bell Set No. 20. This consists of a 4-position rotary type switch and a flag indicator mounted in a wooden box together with a magneto bell and generator. It is suitable only for wall mounting, and since the subscriber usually needs to operate the switch quite frequently, this is a serious drawback in certain situations, such as offices where desks are at a distance from the walls.

With the introduction of the moulded table instrument and the increasing popularity of table telephones generally, attention was directed towards the design of a table set incorporating the switching arrangements required for Plan No. 7. It was also desired to cater for Plans Nos. 5A and 5, which are similar arrangements providing for two extensions, with and without secrecy against the main station respectively, but limited to internal extensions.

The recently introduced Bell Set No. 39 and Telephone No. 248 (Fig. 1) meet these requirements for C.B. and automatic areas. It was decided not to design similar equipment for use on C.B.S. and magneto exchange lines in view of the obsolescent

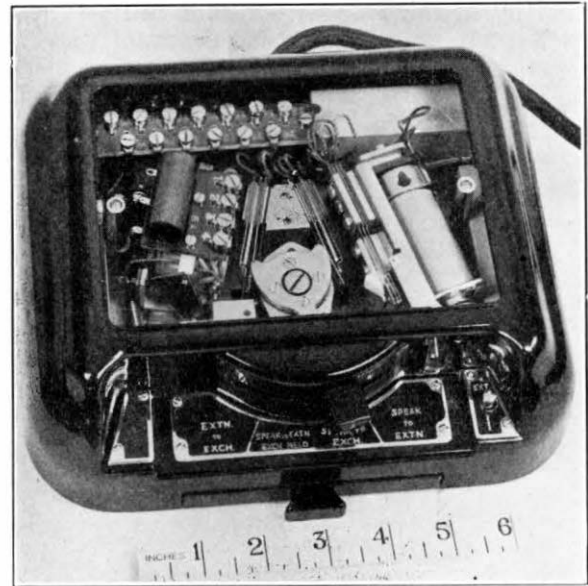

FIG. 2.—BELL SET NO. 39.

nature of these exchanges. At the extension standard instruments are used either incorporating a bell push or with this item mounted separately at internal extensions and with a separate hand generator at external extensions.

Facilities Provided.

The bell set is fitted at the main instrument where exchange calls are normally received, and four switching positions set up conditions so that :

- (1) A conversation can be carried on between the main instrument and an extension, the main calling internal extensions by operating the appropriate press button on the bell set.
- (2) The main station can make calls to, or receive calls from, another subscriber via the public exchange, this being the normal position of the switch.
- (3) The main station can speak to an extension while holding an exchange call without the distant subscriber overhearing.
- (4) The extension can call the exchange direct (subject to the discretion of the main station) in which event a visual indicator on the bell set at the main instrument shows that the exchange line is in use.



FIG. 1.—TELEPHONE NO. 248 WITH BELL SET NO. 39.

General Design.

The basis of design of the new instrument is the familiar two-piece combined table telephone set, the bell set (Fig. 2) being mounted underneath the telephone (supplied "minus base").

A large number of components is required at the main station, and it is clearly impracticable to mount all of them in a table set of reasonable dimensions. The magneto bell or bells are therefore mounted externally in the form of standard bell sets (Bell Sets No. 26). A separate hand generator when an

An extension of the switch arm is fitted with a moulded knob and moves in a horizontal arc in the front of the instrument, an engraved label showing the four switching conditions:—Speak to Extension; Speak to Exchange; Speak to Extension, Exchange Held; Extension to Exchange.

The contact springs are mounted in a vertical plane in four sets, the third set being underneath the first. Access to the lower springs for cleaning purposes is gained through three slots in the metal base plate, the directory tray slide having first been removed. Twin contacts are fitted, and the switch is designed to give a contact pressure of about 150 grammes. Faults on the switch should be comparatively rare, and it is not intended that the local staff should carry out maintenance adjustments.

Press Buttons.

Two press buttons, each operating a single "make" spring set, are provided, one on each side of the switch label, for ringing the extension (Plan No. 7 or 7A internal) or extensions (Plan Nos. 5 and 5A). Either or both the press buttons may be blanked out when not required (i.e., on a Plan 7 or 7A installation) by dummy plates, the plungers being stored in the bends of the lower springs of the spring sets. Alternatively, the dummy plates can be stored by fixing to the filter bracket with the small screw provided for this purpose.

The lower spring is bent up to form a carrier for a moulded saddle which takes the plunger, the complete assembly being self-centring in a conical hole in the bell-set cover.

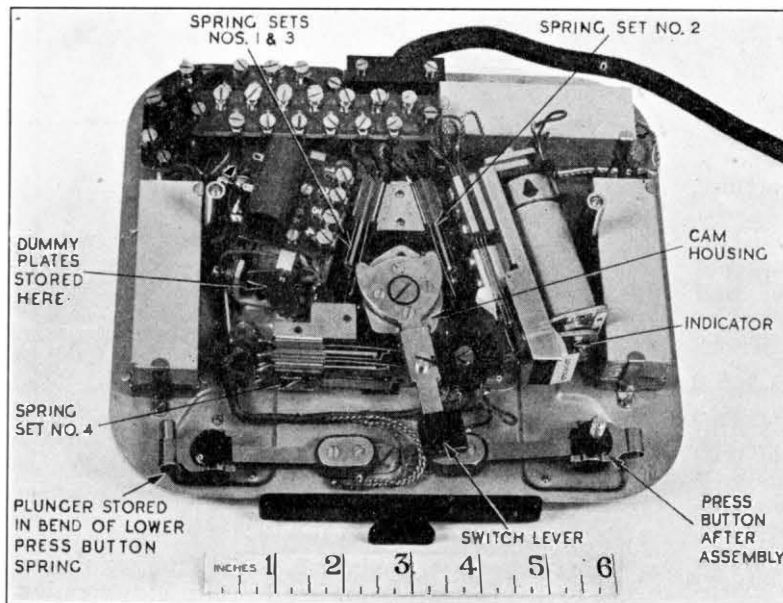

FIG. 3.—BELL SET CHASSIS.

external extension is concerned, and a three-cell Leclanche battery are also provided. The cradle switch, induction coil and dial are accommodated in the usual way in the telephone, while the remaining apparatus, described in some detail in the following paragraphs and shown in Fig. 3, is mounted on the metal baseplate which forms the chassis of the bell set. A sliding tray to accommodate a subscriber's personal directory is provided underneath the bell set.

Switch Unit.

The switch unit is of very robust construction. Fig. 4 shows the principle of the construction adopted. A machined block of metal forms the body of the mechanism and is fixed to the baseplate by four screws. It houses a solid brass cam and is drilled to take 4 steel ball bearings (only 3 are shown in Fig. 4) which are pressed against the cam by flat steel springs. The cam is rotated by the switch lever, and in each of the four positions one or more of the ball bearings is pressed into cavities in the cam. The corresponding movement of the steel springs allows the appropriate contact springs to operate.

A pleasing snap action is thus obtained, and there is little chance of the switch lever being left in an intermediate position.

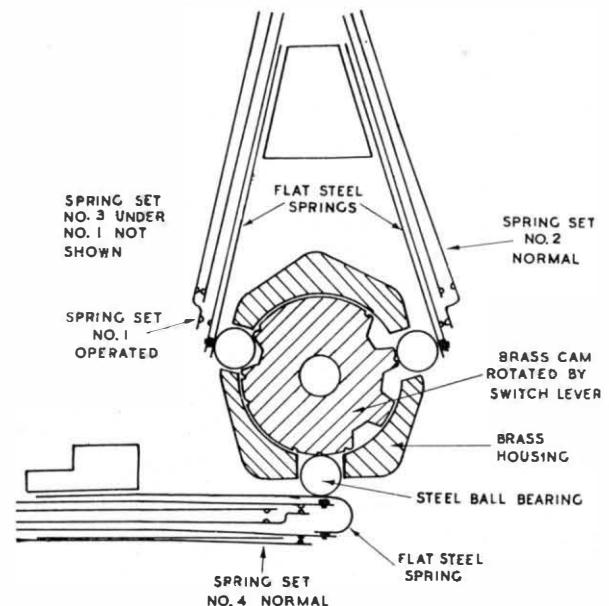

FIG. 4.—SWITCH UNIT (PART SECTION), SWITCH IN "SPEAK TO EXCHANGE" POSITION.

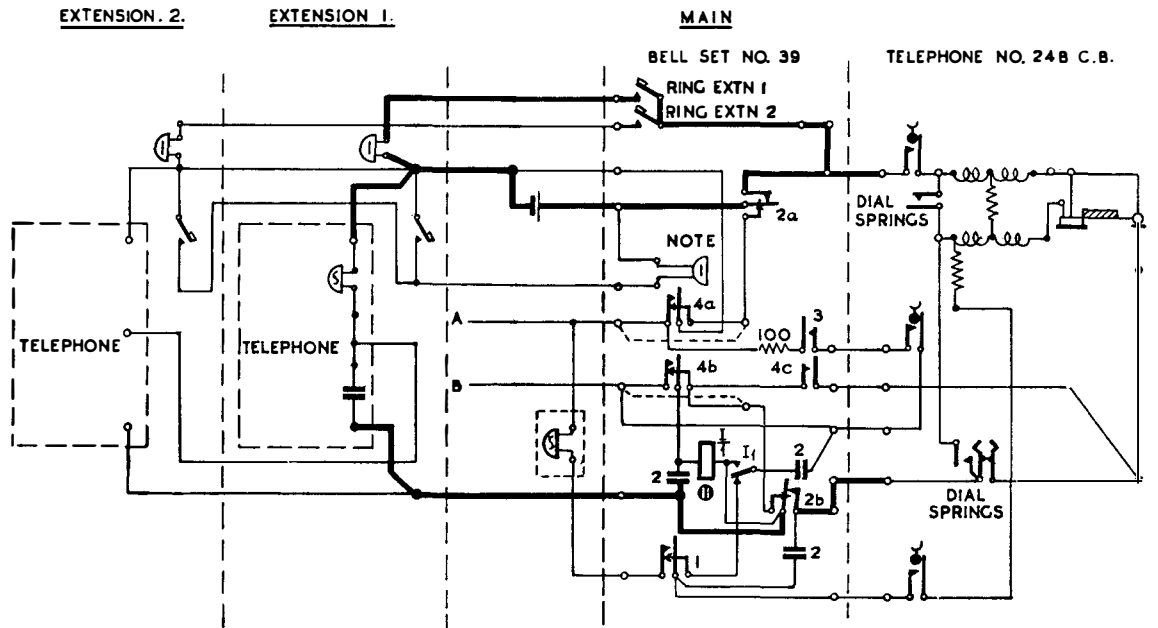

FIG. 5.—DIAGRAM OF BELL SET AND TELEPHONE SHOWING "SPEAK TO EXTENSION" CONDITION.

Indicator.

The indicator is provided to show when the extension is using the exchange line and consists of a 3,000-type relay having one change-over spring set and a flag attachment which shows the word "ENGAGED" through a small glass window in the bell-set cover when the relay is operated.

The indicator is designed to operate on a current of 30 mA and to hold during dialling on a current of 50 mA interrupted for $66\frac{2}{3}$ mS ten times a second. The total resistance during dialling is therefore limited on this account to 1,000 ohms on a 50-volt exchange. With a feeding bridge of $200 + 200$ ohms the limit of total line resistance is thus about 600 ohms, which is somewhat higher than that on transmission considerations. The resistance of the winding is 50 ohms and the transmission loss introduced by the indicator is less than 1 db.

Other Components of Bell Set.

The remaining components are standard items. A buzzer (Buzzer No. 24A) is provided to enable internal extensions to call the main, a filter unit being fitted to prevent radio interference. The exchange line "holding" loop consists of a 100 ohm resistor and a number of standard condensers is also included.

Connections to the bell set are made via two connection strips carrying a total of 25 terminals.

Telephone.

The special telephone introduced for use with the bell set (Telephone No. 248 C.B. minus base) is an ordinary C.B. anti-sidetone hand microphone instrument, but with an additional pair of cradle switch contacts to control the "hold" facility.

Circuit Description.

Fig. 5 is an explanatory diagram of the new bell set and telephone with the necessary wiring for connection to two internal extensions (i.e., Plan No. 5 or 5A). The contact springs operated under the various switching conditions are as follows:—

<i>Position of Switch</i>	<i>Springs Operated</i>
Speak to Exchange	1
Speak to Extension	2
Speak to Extension, Exch. held	2 & 3
Extension to Exchange ..	4

The "speak to exchange" condition is shown in Fig. 6. The exchange ringing circuit is from the

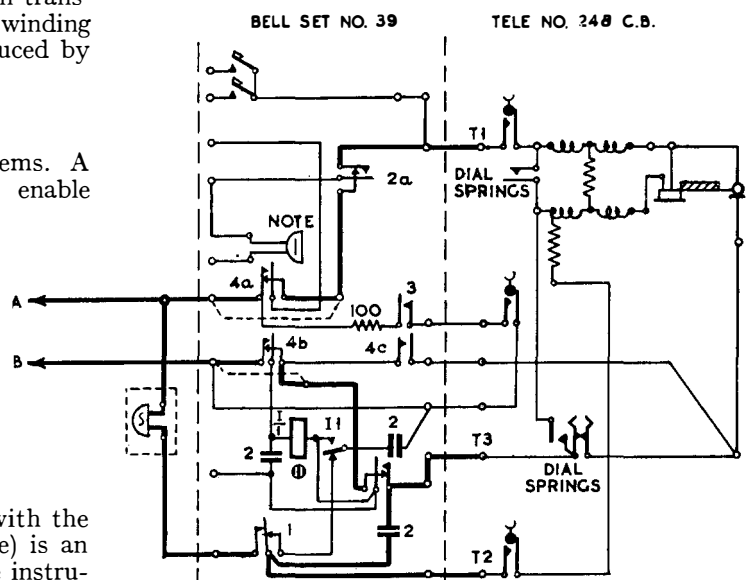

NOTE: BUZZER WITH SUPPRESSOR UNIT.
FIG. 6.—"SPEAK TO EXCHANGE" CONDITION.

A line, through the magneto bell in the external bell set, switch springs 1 operated, $2\ \mu\text{F}$ condenser in the Bell Set No. 39, switch springs 2b and 4b normal to the B line. The exchange speaking circuit is from A wire, through switch springs 4a and 2a normal to telephone terminal T1, from B wire through switch springs 4b and 2b normal to telephone terminal T3, and from the junction of the magneto bell and $2\ \mu\text{F}$ condenser to telephone terminal T2. The connections of the telephone from T1, T2 and T3 are those of a standard C.B. anti-

sidetone telephone. The exchange "hold" circuit is disconnected at switch springs 3 normal.

The main station cannot ring the extensions with the switch in this position, since the press buttons are disconnected from the local battery at contacts 2a normal. Depression of either of the press buttons at the extensions, however, operates the buzzer at the main station by application of the local battery.

In the "speak to extension" position of the switch (Fig. 5) switch springs 2a and 2b disconnect the main telephone from the exchange line and connect it to the extension speaking wires in series with the local battery. The magneto bell is left across the exchange line via the indicator contact I1 (normal) and a different $2\ \mu\text{F}$ condenser. The first condenser remains in the telephone circuit to complete the anti-sidetone balance. Switch springs 2a also prepare the main to extension press-button calling circuit.

In the "speak to extension, exchange held" position of the switch the conditions are similar, but switch springs 3 are operated in addition, placing a 100 ohm loop across the exchange pair in series with the extra cradle switch springs. Thus the exchange line is not engaged if the switch is inadvertently left in this position with the telephone on its cradle.

In the position, "extension to exchange" (Fig. 7), switch springs 4a, b and c are operated. The exchange A wire is connected direct to the extension via the switch springs 4a, and the B wire is connected through the indicator, which is shunted by a $2\ \mu\text{F}$ condenser. The magneto bell at the main instrument remains across the line in series with a $2\ \mu\text{F}$ condenser until the receiver is lifted at the extension, when the operation of the indicator disconnects this bell, and places an additional $2\ \mu\text{F}$ condenser across the indicator. The disconnection of the bell is required to prevent it tinkling when the extension dials.

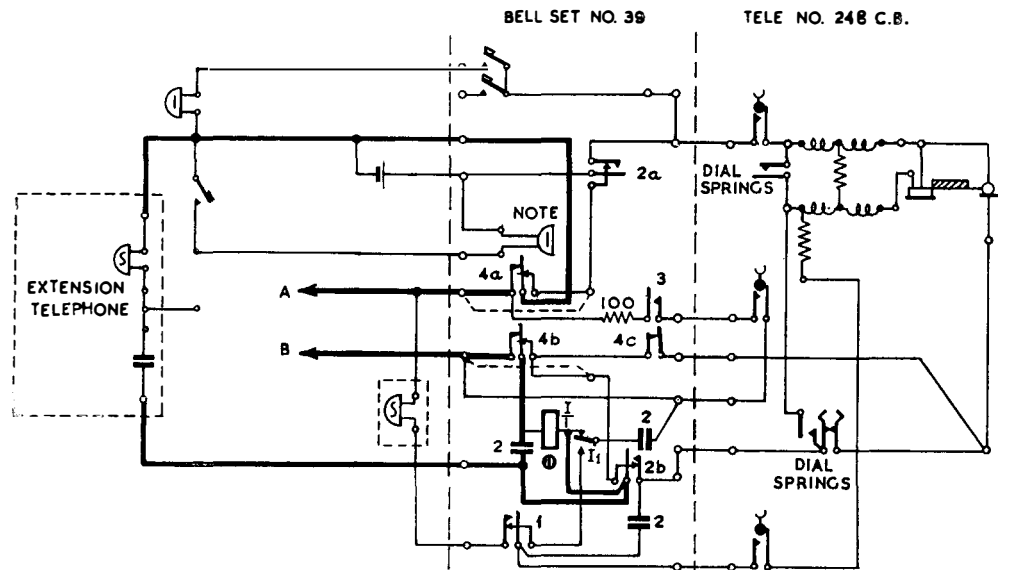

NOTE: BUZZER WITH SUPPRESSOR UNIT.

FIG. 7.—"EXTENSION TO EXCHANGE" CONDITION.

If secrecy against the main station on extension to exchange calls is not required, springs 4a and 4b are strapped, and the main instrument is not then disconnected. Switch springs 4c short-circuit the dial-impulsing springs of the main telephone, preventing this station from dialling and thus tinkling the bells at the extensions. This also prevents the distortion of impulses by the bells and condensers since a caller from the main station must place the switch in the correct position (speak to exchange) in order to dial out.

When the bell set is used with an external extension the battery calling circuits are disconnected and condensed generators are provided at each end of the extension pair while an additional condensed magneto bell is connected at the main station.

Conclusion.

The new instrument is a considerable improvement on the previous equipment, and should meet a long-felt want.

It overcomes two serious circuit difficulties which existed on its predecessor—the "hold" cannot be accidentally left on the exchange line, since it is disconnected by the cradle switch. Also, the impulse springs of the dial at the main station are short-circuited while the switch is in the "Exch. to Extn." position, thus preventing wrong number trouble due to distorted impulses caused by the extension's bell and condenser being connected across the line.

The combined set is more convenient to use and of more pleasing appearance than the old pattern equipment, and its robust construction and easy accessibility should ensure that there will be little trouble from faults.

The instrument has been developed in collaboration with Messrs. General Electric Company, Ltd., of Coventry.

Notes and Comments

Post Office Roll of Honour

We deeply regret to have to record the deaths, while serving with the Armed Forces, of the following members of the Engineering Department :—

Belfast Area : Mulcahy, H., Skilled Workman, Class II, Rifleman, Royal Ulster Rifles.

Blackburn Area : Gooding, R. A., Unestablished Skilled Workman, Signaller, Royal Corps of Signals.

Brighton Area : Fuller, A. J., Unestablished Skilled Workman, Telegraphist, Royal Navy.

Bristol Area : Cook, W. L., Unestablished Skilled Workman, Stoker, Royal Navy.

Edinburgh Area : Crosbie, W. H., Unestablished Skilled Workman, Signaller, Royal Corps of Signals. McGuinness, D. H. G., Unestablished Skilled Workman, Signaller, Royal Corps of Signals.

London Area : Kemp, A. J., Labourer, Able Seaman, Royal Navy. Bridger, H. G., Skilled Workman, Class II, Signaller, Royal Corps of Signals.

Portsmouth Area : Underwood, A. W., Unestablished Skilled Workman, Chief Petty Officer, Royal Navy.

Reading Area : Turner, C., Unestablished Skilled Workman, Private, Royal Berkshire Regiment.

Sheffield Area : Gledhill, E., Skilled Workman, Class II, Signaller, Royal Corps of Signals.

York Area : Sullivan, W. M., Unestablished Skilled Workman, Signaller, Royal Corps of Signals. Taylor, C. H., Unestablished Skilled Workman, Signaller, Royal Corps of Signals.

Col. R. E. B. Crompton

The death of Col. R. E. B. Crompton at the ripe age of ninety-four removes one whose name has been associated with the public supply of electricity from its earliest stages.

Col. Crompton's career was as varied as it was remarkable for, at the age of ten, he served as a naval cadet in the Crimean War before joining the army, which he tried to mechanise sixty years before mechanisation was accepted. Later, in the South

African and Great Wars, he was also called upon to busy himself with mechanisation, and he played a leading part in the development of the tank.

In the electrical field his interests were catholic ; but he will chiefly be remembered for his early work in connection with the introduction of the dynamo and the arc lamp. He was twice President of the Institution of Electrical Engineers and was elected an honorary member in 1923.

Mr. T. O. K. Wylie

A shadow was cast over the evacuation of part of the Engineer-in-Chief's staff to Harrogate by the sudden death of Mr. T. O. K. Wylie, who was in charge of the Telephone Development and Maintenance Branch contingent. Mr. Wylie caught cold on the journey to Harrogate which developed into pneumonia from which he died. His loss has been keenly felt among his large circle of friends, for "Toc" Wylie, as he was affectionately called, was widely known both in his official capacity and in Office and Civil Service sporting circles.

Ten Year Index

Readers will recollect that in 1935 the Board of Editors published a Ten Years' Index to the Journal. It was, at that time, the intention of the Board to revise this Index every five years, and the first revision is therefore now due. In view, however, of the shortage of paper and the increased printing costs, the Board has been compelled to postpone the re-issue of this Index until after the present hostilities. At the same time the Board would point out that a limited number of copies of the original issue is still available, price 6d. per copy, and that annual indexes are published in the fourth part of each volume (January issue).

Cover Paper

Owing to the shortage of paper the JOURNAL has not been able to follow its previous practice of changing the colour of the cover with each new volume, and the colour used during the War will have to depend on the availability of supplies.

Local Centre Notes

London Centre

The Committee of the London Centre, anxious to safeguard the interests of those members who are evacuated to Harrogate, suggested, with the approval of the Council of the Institution, that these would be most satisfactorily served by the formation of a separate group of the London Centre at Harrogate.

To give effect to this suggestion, the following Committee has been elected by the membership at Harrogate:

Chairman, G. F. O'dell, B.Sc., M.I.E.E.; Vice-Chairman, E. S. Ritter, D.F.H., M.I.E.E.; and the following, Messrs. H. O. Ellis, F. C. Foord, W. J. Pemberton, F. T. Perkins, A. G. Stapleton and C. H. Wright, with E. W. Norfolk as Local Secretary and Librarian.

Suitable accommodation has been found and it is proposed to hold the inaugural meeting of the Group early in April, at which the chairman will give an introductory talk.

Scottish Centres

The outbreak of war has been responsible for a severe reduction in the number of students attending workmen's classes in the Scottish Region. The Co-ordinating Committee of the Scottish Centres have decided, nevertheless, to continue the award of prizes to students

taking first and second places in the Grouped Courses and first place in Non-Grouped Classes in Telecommunications subjects at each of the Post Office workmen's classes held within the Scottish Region.

The prizes will be awarded during the current Evening Class Session as follows:—

GLASGOW.

Grouped Courses.—1st Year, 1st 15/–, 2nd 10/–; 2nd Year, 1st 20/–, 2nd 15/–; 3rd Year, 1st 20/–.

Non-Grouped Classes.—1st Year, 1st 10/– (Tech. Elec. I); 2nd Year, 1st 10/– (Telephony I); 3rd Year, 1st 15/– (Telephony II); 4th Year, 1st 15/– (Telephony III).

ABERDEEN.

Grouped Courses.—1st Year, 1st 15/–, 2nd 10/–; 2nd Year, 1st 20/–; 3rd Year, 1st 20/–.

Non-Grouped Classes.—2nd Year, 1st 15/– (Tech. Elec. II and Radio I).

EDINBURGH.

Grouped Courses.—1st Year, 1st 15/–, 2nd 10/–; 2nd Year, 1st 20/–, 2nd 15/–; 3rd Year, 1st 20/–.

Non-Grouped Classes.—1st Year, 1st 10/– (Tech. Elec. I).

The prizes are known as the Scottish I.P.O.E.E. prizes, and funds for their provision are being raised by subscription from members, associate members and associates of the Institution in Scotland.

Regional Notes

London Telecommunications Region

ORSETT U.A.X. ISOLATED BY SNOW

During the evening of January 29th, 1940, the emergency maintenance officer was called out to attend to a fault at Orsett U.A.X. He endeavoured to reach the exchange driving a Morris Minor van, but found that the roads were blocked by snowdrifts and, in the dark, he was unable to get nearer than three or four miles from the exchange. The following morning, in the daylight, he drove as far as possible, and completed the journey on foot, one hour ten minutes' walking, and cleared the fault.

Although it may be fairly common to experience similar or much worse transport difficulties in other Regions, it is probably unique for weather conditions to make it impossible to reach an exchange in the London Telecommunications Region except on foot.

OPENING OF TADWORTH U.A.X. No. 14

Tadworth is the first U.A.X. No. 14 to be installed in the London Region. The opening took place at 1.30 p.m. on January 17th, when 540 subscribers were transferred from Burgh Heath manual exchange. The initial capacity of the exchange is 680 lines and the ultimate 800. The equipment was installed by Messrs. Ericsson Telephones Limited. A parallel float power plant has been provided with a battery capacity of 120 Ah.

The auto-manual board is located at Burgh Heath manual exchange.

"DAILY NEWS," BOUVERIE STREET, E.C.4

This subscriber was served by a Relay P.A.B.X. 24 V equipment with a capacity of 180 lines, 17 trunks and 5 manual positions, but owing to an extension of premises the present accommodation was not suitable. Three rooms in the new premises were accepted for a new line finder automatic equipment, manual switchboard and batteries respectively, the automatic equipment and manual switchboards being provided and installed by Messrs. Automatic Electric & Telephone Co., Ltd., and the batteries and charging plant by the Department. The new equipment provides for 400 lines and 6 manual positions, leaving ample space for extension.

P.B.X. REMOVAL

Owing to the difficulty of obtaining equipment, a very busy suite of four No. 9 B.E.C.B. switch-sections and associated equipment was completely removed from Provincial House, Cannon Street, to Eagle House, Cannon Street, during Saturday afternoon and Sunday. The change, which was satisfactorily effected, reflects no small amount of credit on the engineering staffs concerned.

FARADAY BUILDING REPEATER STATION AND TRUNK AND TOLL POWER PLANTS

During the last two years considerable rearrangement of power plant, cabling and battery work in Faraday Building has been undertaken by contractors and the Department, with the following results:—

London Repeater Station.

The development of long distance communication has progressed so rapidly that within three years of the installation of the first separate power plant for the London repeater station, it was decided in 1938 to provide a new installation.

The original plant installed by Newton Bros., Derby, Ltd., in June, 1935, consisted of two "A" batteries of 2,000 Ah capacity and two "B" batteries of 230 Ah capacity on Divided Battery Float system, using two 24 V, 300 A "A" generators and two 130 V, 40 A "B" generators. The output of these machines was controlled by Isenthal automatic voltage regulators. The motors were of squirrel-cage type with star-delta starters.

During 1935 the discharge load for the repeater equipment was approximately 100 A for the "A" battery and 5 A for the "B" battery, and in 1936 gradually increased to 600 A and 20 A respectively.

In 1937 Messrs. Austinlite, Ltd., of Birmingham, were given a contract for the extension of the power plant to provide two new "A" generators and two new "B" generators of similar output to the machines already in service and an entirely new switchboard. The capacity of the A and B discharge switches was increased to 1,200 A and 50 A respectively. Isenthal automatic voltage regulators were again provided with compound windings to permit paralleling the machines. The additional generators had one motor common to both A and B generators.

The capacity of the batteries was not increased at this stage.

Between 1935 and the end of 1937 the A battery discharge load had increased to 1,000 A, and it became necessary at times to float with four machines to meet the requirements of the station.

During 1938 Messrs. G.E.C., Ltd., Witton, were given the contract to provide an entirely new power plant. To provide accommodation for the new equipment, the existing four A and B generators were removed from their beds and placed on temporary wooden structures with temporary cabling between the switchboard and machines.

The new machines, which were brought into service in December, 1939, comprise two sets of A and B generators and a motor on a common shaft, each motor being 145 B.H.P. induction type with wound rotor short-circuited when running at normal speed of 585 r.p.m., taking 199 A at 400 V A.C. on load.

The A generators are 24/32 V at 2,500 A (63 kW) and the B generators 130/175 V at 200 A (27 kW).

Between the machines and the switchboard smoothing circuits have been installed for each machine, the chokes for the A generators being the largest installed in a Post Office repeater station.

The voltage regulators are of the carbon pile type manufactured by Messrs. Stones, Ltd., Deptford, and the main discharge switchgear has a carrying capacity of 3,000 A.

Two new "A" batteries of 8,000 Ah capacity and two "B" batteries of 600 Ah capacity have been provided.

The present daily load is now:—"A" battery (24 V), 36,000 Ah; "B" battery (130 V), 1,680 Ah.

Trunk Exchange Power Plant.

January this year has seen the completion of approximately three years' work in connection with the rearrangement of the trunk exchange power plant and the provision of a new power switchboard and additional motor generators.

The whole of this plant is now situated in one large room in the sub-basement of the exchange building. The work was commenced early in 1937 by the provision of temporary 24 V panels removed from the old City exchange switchboard to which was connected a new 24 V battery of 7,500 Ah capacity. The removal of two old City manual exchange 10,000 Ah batteries made available space for the two 50 V 10,750 Ah batteries for the Trunk and Toll A exchanges, the capacity of the old Trunk battery being 7,500 Ah. The whole of this work was undertaken by the Department.

Early in 1938 the Standard Telephones & Cables Co., Ltd., transferred the Central 1,600 Ah motor-generator set from the old Central test room to the new site, and also the City 24 V 1,200 Ah set to another bed in the new room. These were connected to the 24 V switchboard to supply current to the radio telephone terminal and Toll A on a discharge basis, but floating may be resorted to when necessary. These motor sets are of the induction type with wound rotors.

The next step in the reorganisation of the 50 V Trunk switchboard was brought about by supplying various floors with separate cable leads and breakers for individual floors. Particulars of breakers are as follows:—

Ground floor	1,600 A
1st floor	1,200 A
2nd floor	600 A
3rd floor	800 A
4th floor	400 A
5th floor, S Block		250 A
5th floor, N Block		800 A

The panel accommodating the breakers is equipped with an ammeter and switch which enables the current discharge readings to be taken for each floor.

The battery room floor was then strengthened to take the extra weight of new apparatus and machines, and was actually raised to a new floor level with approximately 7½ in. of concrete above the old floor. It was not necessary to move the position of the existing 1,200 A 50 V synchronous machines, which are driven by 104 h.p. motors, but two new motor generators with output of 2,200 A, driven by 167 B.H.P. motors of the induction type operating from 400 V A.C. mains, have been lined up with the existing machines. The new machines were provided by Messrs. Bruce Peebles, Ltd., Edinburgh. Suitable chokes have been connected to each of the generators to minimise machine noise.

The whole of the new plant works on a Divided Battery Float System, the 2,200 A generators being controlled by automatic voltage regulators. A new discharge switch panel has been installed, the capacity of the main switches varying from 3,000 A to 6,000 A. The shunt in the discharge circuit has a carrying capacity of 6,000 A, and is made up of two 3,000 A shunts erected as a single unit. It is understood this is the largest of its kind in the country.

The work has involved a considerable amount of cable rearrangements and the provision of new cable runs, and temporary panels have been installed from time to time in order not to affect in any way the service to the 10 Trunk and Toll exchanges, and was carried out, in the main, by the Standard Telephones & Cables, Ltd., in conjunction with the Department.

Home Counties Region

DAMAGE CAUSED BY BURST WATER MAIN

During the early evening of February 7th, 1940, a cracked 6-in. water main in Gordon Street, Luton, Beds, caused a considerable subsidence of the carriage-way and footway, the moving soil allowing a 9-way duct carrying two large cables to become very much out of alignment.

The effect of this movement was to take up the slack of the cables in the adjoining manholes and to cause one of these cables to act as a support to the duct line. As a result, the cable was found to be pulling hard against the mouth of the duct. As approximately 600 local circuits were working in this cable, great concern was felt, but actually no faults occurred.

Adjacent to this 9-way duct and the building line is a 5-way duct carrying, with other trunk and local cables, the TSX-BM coaxial cable, and as some anxiety was felt in respect of this track, poles were placed across the gap—caused by the subsidence—on to solid ground.

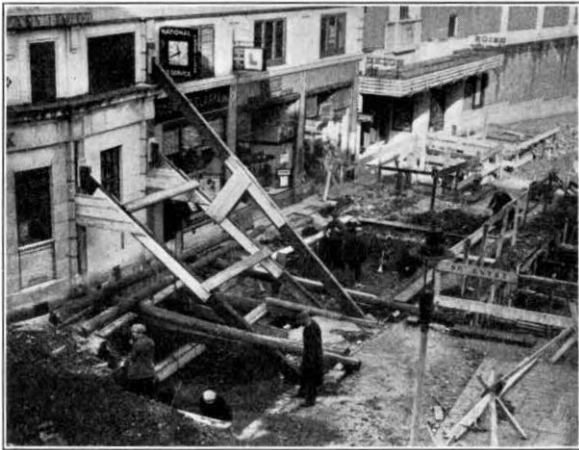

Both duct lines were eventually suspended from these poles. The slack on the cables was then pulled back into the manhole, and the 9-way duct line lifted back into its original position.

Apart from the damage to this Department's plant it was feared the adjoining buildings were in danger of being affected as the subsidence disturbed the soil up to the footings; therefore precautionary measures had to be taken as will be seen in the photograph, by courtesy of the *Luton News*.

FLOODING AT BEXHILL TELEPHONE EXCHANGE

As dampness is generally regarded as an undesirable element in a telephone exchange switchroom, the presence of two inches of water on the floor and a steady cascade through the ceiling on to the switchboard of Bexhill exchange, on the night of January 21st, provided a pretty problem for the engineers and a situation with which no adjective in Departmental terminology could adequately cope. The sudden and unexpected arrival of so much superfluous liquid was due to the failure of an unlagged water pipe in a loft overhead—a legacy of the recent great "freeze-up." When the water came in, the circuits went out; all incoming junctions and 150 subscribers were the first casualties. An S.O.S. was sent out at 7.10 p.m.; emergency linemen, despite appalling road conditions, rounded up all suitable staff available. Meantime, the Engineer-in-Charge, assisted

by a lineman, set about restoring the junction service, and by midnight 50 per cent. of the circuits from London and Hastings were working, and the remainder were restored four hours later.

With the arrival of the "rescue" party, equipment and switchboard cable runs were opened up and hot air applied from a vacuum cleaner adapted as a blower. By 8.0 a.m. only four subscribers' circuits were out of service and these were soon in order. Subsequently, some faults of short duration were observed. A peculiar discolouration of wires and equipment indicated the presence of impurities in the water, with a consequent deleterious effect on the metals. A close examination of all equipment and cables together with insulation tests, showed that the corrosive action of the water had seriously affected the lower rows of answering jacks and cabling. Extensive renewals are now proceeding.

Not content with sabotaging the switchroom, some of the water percolated to the battery room below, and found its way into the main batteries. A drop of 8 degs. in S.G. of one cell resulted; the necessary attention was accordingly bestowed.

Moral.—If you must have water pipes over a switchroom, lag them.

EPPING TELEPHONE EXCHANGE

On Saturday, February 3rd, 1940, at 2 p.m., the first transfer to take place since the formation of the Home Counties Region was successfully carried out: namely, the conversion of Epping Exchange from C.B.S.2 to automatic working. The new exchange is of the Non Director 2,000-type with uniselectors, and is the first of its kind to be installed by Messrs. Standard Telephones & Cables, Ltd. The equipment, which is housed in a two-storey building pleasantly situated just off the main London road, provides for 700 lines multiple initially with a 7-position manual board, capacity being provided for 1,200 lines multiple. The exchange is served by a standard parallel battery float power plant with 300 Ah batteries and two, with an ultimate of three, 15A mercury arc rectifier units with automatic control.

The transfer of 445 subscribers' lines and 78 junctions was carried out, and interdialling has been provided between the U.A.X.'s connected to Epping. It is worthy of mention that in spite of the most severe weather conditions during the preceding week and the ice and snow-bound conditions prevailing at the time of the transfer, only three faults were recorded during the normal testing period after the transfer.

Midland Region

The opening of the Midland Region removes another landmark of the Post Office Engineering Department, viz., the office of the Superintending Engineer, North Midland District, Nottingham. The North Midland District, which covered the telephone areas of Coventry, Leicester, Peterborough and Nottingham has now been merged with the telephone area of Birmingham to form the Midland Region under the directorship of Mr. J. J. McKichan, O.B.E., with Regional headquarters at Birmingham. The telephone area of Stoke-on-Trent will be included in the Region in the near future.

Major L. H. Harris, the late Superintending Engineer of the North Midland District, has been appointed Chief Regional Engineer of the new Region, but owing to his absence on military service the duties of Chief Regional Engineer have been taken over by Mr. A. Speight, Staff Engineer of the Engineer-in-Chief's Office.

The Engineering Branch of the Regional Headquarters, for the time being, is being retained at

Nottingham, but will be transferred to Birmingham when accommodation is available.

The activities of the Institution will still be carried on in the old North Midland District by the retention of the Nottingham Branch, and will cover the telephone areas of Leicester, Peterborough and Nottingham. A new branch of the Institution will be formed at Birmingham, to cater for the requirements of the telephone areas of Birmingham, Coventry and Stoke-on-Trent. Both branches will be under the chairmanship of the Chief Regional Engineer, Midland Region.

BIRMINGHAM TELEPHONE AREA

The automatising of the Birmingham Telephone Area is steadily progressing. With one exception the Director Area is now completed. Worcester and Kidderminster were successfully transferred in mid-October. Bearwood and Lichfield will, it is hoped, be converted by the date of this publication. It is well known that Kidderminster is the birthplace of Sir Rowland Hill, and the Office of Works have provided an unusual type of building, particular points of interest being the interior decoration in the main hall and staircase.

North-Eastern Region

DURHAM COUNTY COUNCIL AND POLICE HEADQUARTERS SWITCHBOARD

The Police Headquarters switchboard, a C.B.9 multiple type with two sections, is one of the most important installations in County Durham and is the centre of a network of circuits which carry A.R.P. traffic.

Some weeks before the outbreak of war, the police authorities considered that its position on the first floor of the building was too vulnerable in event of air raids, and requested removal to the ground floor where better protection could be afforded.

As the switchboard carries heavy traffic and is continuously attended, it was intended to install new switchboards on the ground floor and arrange a simultaneous transfer.

Two weeks before the outbreak of war, however, the police authorities made a request for the work to be carried out at the earliest possible moment. The new switchboards had not arrived, and enquiries to Controller of Stores and other possible sources of supply, showed that delivery could not be expected for several months. As the police authorities were alarmed at the vulnerability of the boards and were very anxious for early completion, it was suggested that a large hole be cut in the floor and the installation lowered en bloc to the floor below. After consultation with the Borough Surveyor, this was agreed, and a date, which proved to be an eventful one, viz., Sunday, September 3rd, 1939, was fixed for the operation. The preliminary work of lengthening the cables to the existing M.D.F., fixing a new M.D.F., etc., was put in hand forthwith, and at 10.0 a.m. on September 3rd the actual removal commenced. The switchboards were raised on to a timber raft which was to be lowered by block and tackle from beams specially erected above the boards. In order that the telephone service would not be interrupted, the raft was constructed large enough to accommodate the operators, who would attend to calls during the lowering. At approximately 11.0 a.m. the raft carrying

the switchboards and one operator was raised a few inches to remove the weight, approximately 12 cwt., from the floor, while a squad of carpenters commenced cutting away the floor joists and boards. The work had hardly begun when the first air-raid warning of the War was sounded, and a second operator was necessary to handle the telephone traffic. The removal operations were, of course, temporarily suspended for the period of the alarm. When the work was resumed, the switchboards and operator were lowered through the hole in the floor without further unexpected incident. During the whole of the operation not a single call was lost or delayed, and continuous service was maintained.

The floor was then replaced by steel and concrete to afford maximum protection, this work being commenced by the builders on the same day immediately Post Office operations permitted.

PROVISION OF EMERGENCY SERVICES AUGUST-SEPTEMBER, 1939

In common with most parts of the country the Bradford Area found itself faced with a formidable task at the beginning of the war. The staff responded well, and new line completions during four very busy weeks were 100 per cent. above normal.

Though we had the ready co-operation of the Stores Department—to whom tribute is due—a daily watch on the stores position was necessary, and resulted in there being no serious delay through lack of stores.

SNOW STORM, FEBRUARY, 1940

Heavy falls of snow late in January—with drifts 15 ft. deep for long sections along one trunk route—caused no major breakdowns, but changing conditions and hard frosts early in February caused ice up to 2½ in. in diameter to form on the wires. Complete details of the damage are not yet available, but the damage is extensive. Broken routes are mostly on high ground in open country.

One interesting feature was an aerial cable which remained intact and undamaged after the pole head had broken off with all its open wires. In another place small cables were severed in iron conduits due to ice expansion, most of these faults being in leads-in to kiosks.

Numerous exchanges were isolated, and great difficulty was experienced in getting through the abnormal snow drifts to effect repairs.

The staff have worked well in bad weather conditions. Vehicles have been taken as near as possible to the damaged routes, but often stores, tools and ladders have been carried over the snowdrifts. Solid blocks of ice covering the arms and insulators have added further to the difficulties.

One of the lessons to be learnt from this storm is that it is not economical to leave a large number of spare wires on trunk routes.

COL. J. C. CHAMBERS, C.B.

A link with the earliest days of the telephone in Leeds was broken by the death, on February 6th, of Col. J. C. Chambers, who was a friend of Graham Bell.

Col. Chambers was manager of the first telephone exchange in Leeds at a time when there were only ten subscribers in that city, and he later served with the National Telephone Company, from which company he retired in 1911. He was 83 when he died.

Book Reviews

"History of the Institution of Electrical Engineers (1871-1931)." Published by the Institution. Price, 12s. 6d. to Members, 18s. 6d. to Non-members. 342 pp.

In 1931 the Institution of Electrical Engineers completed sixty years of existence, and the Council decided that a history of this period should be prepared and published. By a wise choice they entrusted Commander Rollo Appleyard, O.B.E., with the task of writing this history, and the resulting volume is a credit to the author and to the History Sub-committee under whose advice the work was produced.

The book consists of an introduction, eight chapters and eight appendices. The introduction gives a brief outline of the development of electrical knowledge from the time of Gilbert who published his work "De Magnete" in 1601 down to about the time when the Institution was founded in 1871 under the title of the Society of Telegraph Engineers. The years immediately preceding the formation of the Society had been ones of great activity in the field of electrical research marked particularly by the great discoveries of Faraday which changed the whole course of electrical development and by the advances in telegraphy culminating with the completion of the first successful Atlantic cable in 1866. The internal telegraph system in Great Britain had been taken over by the Post Office early in 1870. Thus the stage was set for the inauguration of a society to interest itself in the new technique, and on May 17th, 1871, eight persons met in No. 2 Westminster Chambers, Victoria Street, S.W., to consider the expediency of forming such a society. They were W. Whitehouse, Capt. P. H. Colomb, R.N., Major R. H. Stotherd, R.E., Louis Loeffler, Capt. C. E. Webber, R.E., Capt. E. D. Malcolm, R.E., Robert Sabine, Major Frank Bolton. At a meeting on May 31st the Society was inaugurated, C. W. Siemens being elected president and Lord Lindsey and Frank Ives Scudamore, vice-presidents. Siemens, afterwards Sir Charles Siemens, F.R.S., had become a naturalised Englishman in 1859 and had established the electrical works at Charlton in 1866. Lord Lindsey was a gifted amateur (in the true sense of the word) in electricity and other sciences; while Scudamore was Secretary to the Post Office and had been largely instrumental in carrying out the transfer of the telegraph service from private to public ownership. Scudamore succeeded Siemens to the Presidency of the Society in 1873. In his turn he was succeeded in 1874 by the most famous personality to hold this position, William Thomson, afterwards Lord Kelvin.

The first chapter, entitled "The Founders," deals in detail with the eight members at the preliminary meeting and also with the original 66 members. It is interesting to note among these original members many who rose to high rank in the Post Office Engineering Department—for example, R. S. Culley, E. Graves and W. H. Preece.

The second chapter, entitled "The First Decade," deals with the progress of the society during that period. H. R. Kemp, although not an original member, was one of the early associates. In these early days the finances of the Society were not by any means in a flourishing condition, and it required careful management to make both ends meet. In 1874 the Society acquired offices in Broad Sanctuary, Westminster, at a rental of £150 per annum, and the Secretary's salary at this time was also £150 per annum, having been increased from an original figure of £100 per annum.

It is interesting to note that the Society applied for a Royal Charter of Incorporation in 1880, but this request

was refused; as a result steps were taken to register the Society under the Companies Acts.

The third chapter, "The Transition," deals with the period from about 1881 to 1889. This period seems to have been marked by the development of electric lighting and the development of the telephone.

In December, 1880, a General Meeting carried a proposal to change the title of the Society to "The Society of Telegraph Engineers and of Electricians." In course of time the second "of" was dropped. The change of name was an indication of the widening interests of the Society, and this change was followed in 1887 by a second change to The Institution of Electrical Engineers. Appropriately, Lord Kelvin was again elected President, and so became the first president of the Institution under its present title.

The remaining chapters are entitled "The Institution in Being," covering the period 1889 to 1900; "The Pre-War Period, 1900 to 1914"; "The War Period"; "The Restoration and Advance, 1918 to 1931"; and, finally, "The Precincts."

During the last war the total membership was just under 7,000; over 1,600 members served in the fighting forces, and 162 gave their lives. An alphabetical list of those who fell is contained in the chapter on "The War Period."

The final chapter is one of the most interesting. The site on which the present Institution building stands is one of great historical importance, and its history is outlined by the author in a most interesting narrative. The inclusion of reproductions of old prints and maps adds to the interest.

The volume is completed by a biographical list of presidents, with photographs, and by various other appendices, including the text of the Royal Charter and that of the first Wiring Rules; the latter make very amusing reading.

The book is written in a most attractive style, and is full of topical and often amusing anecdotes and quotations which lighten the subject and hold the attention. Little intimate touches relating to many of the great figures of the time such as Faraday, Hughes, Heaviside, Clark Maxwell and many others are included. The Institution has identified itself with Faraday so closely even to the adoption of his profile as the seal of the Institution, that one feels some little regret that the information regarding him is not more extensive and in a more collected form rather than being dispersed as it is throughout the book, but no doubt exigencies of space prevented this. It is a volume which every member of the Institution and everyone else interested in the history and development of electrical engineering, should possess.

A. J. G.

"Problems in Radio Engineering." E. T. A. Rapson, M.Sc.(Eng.), A.C.G.I., D.I.C., A.M.I.E.E., A.Inst.R.E., F.P.S. 123 pp., 14 ill. Pitman. 3s. 6d.

This book, the fourth edition of which has just been published, is primarily intended to provide exercises for students of radio engineering. It is divided into 44 sections dealing with different branches of the subject. Each section consists of a number of questions extracted from examination papers of the City and Guilds Institute, the Institution of Electrical Engineers and the University of London, and generally the questions are preceded by statements or brief clear explanations of the more important formulæ related to that portion of the subject. The answers to numerical problems are

given at the end of the book, and frequently the working is given in full.

Some ambiguity has crept in on page 42 where T is rather loosely defined as the step-up ratio of an output transformer; it is necessary to inspect the expression in which T is used in order to discover that T is really the ratio of the primary turns to the secondary turns. The first part of section 26 could also be improved; the expression for the field at a distance from an antenna array is given as:—

$$F = F_1 \frac{\sin(N\alpha/2)}{\sin(\alpha/2)}$$

“where
 α = phase difference between consecutive aerials
 also $\alpha = 2\pi a \sin \theta/\lambda$ ”

This double-barrelled and not entirely correct definition of α should read:—

$$\alpha = 2\pi a \sin \theta/\lambda + \Phi$$

where Φ = phase difference between currents in adjacent aerials.”

Just below, F, it is stated, vanishes when $N\alpha/2 = 0$ or π . This is not so. $N\alpha/2$ becomes zero when $\alpha = 0$ and the numerator and denominator in the expression for F both vanish. By taking the limit to which F tends as α approaches zero it can be shown that when $N\alpha/2 = 0$, $F = F_1 N$.

Apart from the examples quoted, the book appears to be exceptionally free from errors. It is a cheap investment which every student who wishes to obtain practice in answering examination questions should buy.

H. S.

“Mathematics Applied to Electrical Engineering.”
 A. G. Warren. With a foreword by Alexander Russell, F.R.S. 400 pp. 132 ill. Chapman & Hall. 15s.

This book is the ninth volume of a series of monographs on electrical engineering edited by Mr. H. P. Young. The aim of the series is to enable engineers to obtain works on special subjects which are either ignored or inadequately dealt with in standard textbooks. In this monograph the author has included those parts of mathematics which, during some thirty years' experience in engineering education, he has found of most assistance in his work. There are chapters on harmonic and vector quantities, symmetrical components, partial differentiation, differential equations, Bessel functions, Fourier series and harmonic analysis, Heaviside's operational calculus, and conjugate functions. There are worked examples on the operation of transformers and alternating-current generators, valve oscillators, moving-coil speakers, high-frequency resistance, inductive heating, flux waves, transmission of waves, etc. The author has turned out a book that will be useful to engineers. The type is easy to read and the diagrams are clearly constructed. There is much to praise and little to blame. But, as space is limited here, we shall leave out the praising: a few critical remarks are likely to be more useful in the long run.

On page 135 the author discusses differentiation under the integral sign, but omits the most important case of variable limits. In view of the fact that the practical application of the fundamental theorem of electric circuit theory, namely,

$$I(t) = \frac{d}{dt} \int_0^t A(t-\psi) E(\psi) d\psi$$

involves the differentiation of a definite integral with variable limits, the author's omission of this case is remarkable.

Although the book is, on the whole, commendably free from any straining after rigour, one feels that the treatment of the coaxial cable and other problems involving Bessel functions in Chapter 18 is so very brief and condensed that the student will be compelled to consult Russell's "Alternating Currents" to obtain a satisfactory discussion.

The author's discussion of Heaviside's operational calculus is too brief to be of much use to the engineer. On page 306 there are some critical comments on Heaviside's methods. One reads that Heaviside . . . "gave no adequate discussion of his methods. Theorems were used without any real indication of their validity." This is fudge and fiddlesticks. Heaviside proved his theorems many times and in many ways. For example, he proved his expansion theorem twice, although this fact remained unrecognised by many, until Mr. M. S. Vallarta rearranged and presented the first proof and called attention to the second. Another fact that still remains unrecognised by many writers is that the famous Carson integral theorem was first demonstrated by Heaviside in his "Electromagnetic Theory," Vol. III, p. 237. Heaviside did not rely on this theorem to establish operational formulæ: but rather employed it to evaluate infinite integrals when the result of the corresponding operational expression was known. It is of use either way. Since there are other valid ways of substantiating operational formulæ beside the integral theorem, the expansion theorem or series developments following Volterra or Wiener, the use that Heaviside made will probably become the more valuable process as operational schemes are further developed. H. J. J.

“Notes on Soldering of Lead Pipes and Sheet Metal.”
 The International Tin Research and Development Council.

This booklet is issued for guidance in the use of solder for plumbing and sheet-metal working and gives quick reference to the properties of various grades of solder. Wiped joints are dealt with at length, each operation being treated separately. Special emphasis is laid on the importance of temperature in relation to joint porosity and kindred defects.

The book, which is well illustrated in line and half-tone should be of particular interest to all who are concerned with plumbed joints.

Copies are available, gratis, from:—International Tin Research and Development Council, Fraser Road, Greenford, Middlesex. P.D.M.

Staff Changes

Promotions

Name	Region	Date	Name	Region	Date
<i>From Exec. Engr. to A.S.E.</i>			<i>From Dr'man Cl. I to Senior Dr'man.</i>		
Rumley, B. C. H.	.. S.W. Reg. 8.12.39	Lipscombe, C. A. D.	.. E.-in-C.O. 22.1.40
Hollinghurst, F.	.. Rugby R.S. to E.-in-C.O. 11.12.39	<i>From Chief Insp. to Asst. Engr.</i>		
Harrison, R. H.	.. E.-in-C.O. 11.12.39	Woodhead, H. C.	.. Rugby R.S. 12.12.39
Smith, H. S.	.. E.-in-C.O. 6.3.40	Gaunt, G. L.	.. Scot. Reg. to E.-in-C.O. 29.12.39
<i>From Exec. Engr. to Reg. Engr.</i>			Blight, A.	.. L.T. Reg. 11.1.40
Hodge, G. W.	.. H.C. Reg. to N. Ire. Reg. 13.2.40	Denney, E.	.. L.T. Reg. 11.1.40
<i>From Asst. Engr. to Exec. Engr.</i>			Symonds, A. E. J.	.. E.-in-C.O. 22.2.40
Vickers, G. H.	.. Rugby R.S. 12.12.39	Buy, H. A.	.. H.C. Reg.	.. To be fixed later
Davis, L. H.	.. E.-in-C.O. 30.12.39	Greenwood, G. C.	.. H.C. Reg.	.. To be fixed later
Gill, O. W.	.. E.-in-C.O. 30.12.39	Peddle, H. W.	.. Mid. Reg. to E.-in-C.O.	.. To be fixed later
Stanton, E. P.	.. E.-in-C.O. 30.12.39	Watt, J.	.. E.-in-C.O. 22.2.40
Hamilton, R. N.	.. H.C. Reg.	To be fixed later	Grant, C. G.	.. E.-in-C.O. 22.2.40
Salt, R. S.	.. L.T. Reg. 30.12.39	<i>From Chief Insp. to Chief Insp. with allowance</i>		
Knight, N. V.	.. L.T. Reg. to Stoke	To be fixed later	Manton, C. H.	.. L.P. Reg. 31.12.39
Neale, J.	.. E.-in-C.O. 30.12.39	<i>From Insp. to Chief Insp.</i>		
Brock, P. R. W.	.. E.-in-C.O. 30.12.39	Jimpson, S. J.	.. E.-in-C.O. 25.10.39
Metson, G. H.	.. N. Ire. Reg. to E.-in-C.O. 30.12.39	Lynes, F. A.	.. Oxford R.S. 23.10.39
Cawsey, A. J.	.. S.W. Reg. 2.1.40	Ottaway, A. C.	.. L.P. Reg. 1.1.40
Cherry, D. W.	.. Test Secn. Ldn. 2.1.40	Wilson, L. P.	.. E.-in-C.O. 14.1.40
Farren, P. E.	.. W. & B.C. Reg. 2.1.40	Marshall, W. J.	.. E.-in-C.O. 22.2.40
Brown, H. R.	.. E.-in-C.O. 1.3.40	Shearing, M. R.	.. E.-in-C.O. 1.2.40
Ellis, H. O.	.. E.-in-C.O. 2.1.40	Wilcock, A.	.. E.-in-C.O. 1.2.40
Freebody, J. W. H.	.. E.-in-C.O. 1.3.40	Edwards, W. W.	.. Mid. Reg. 27.3.39
Mitchell, H. T.	.. E.-in-C.O. 17.2.40	<i>From S.W.1 to Insp.</i>		
Williams, F. E.	.. E.-in-C.O. 17.2.40	Roberts, C. A.	.. E.-in-C.O. 14.7.39
Rhodes, J.	.. E.-in-C.O. 17.2.40	Winson, R. W.	.. E.-in-C.O. 13.8.39
Wood, A. E.	.. E.-in-C.O. 17.2.40	Middleton, K. M.	.. Portishead R.S. to St. Erth 2.9.39
Robinson, R. P.	.. H.C. Reg. 10.1.40	Evans, J. R. W.	.. St. Albans R.S. to Lydd 8.8.39
Rousell, S. M. E.	.. L.T. Reg. 30.12.19	Webber, C. W. A.	.. Portishead R.S. to Thurso 20.8.39
Preston, S.	.. N.E. Reg. 21.1.40	Hopkins, A. J.	.. Baldock R.S. 29.7.39
Charles, F. N.	.. Mid. Reg. to H.C. Reg. 14.1.40	Hugman, H. L.	.. R.T.T. 16.4.39
Atkinson, J.	.. N.W. Reg. to Scot. Reg. 17.1.40	Foster, H. W.	.. E.-in-C.O. 12.11.39
Bland, F. E.	.. Mid. Reg. to Scot. Reg. 28.1.40	Chapman, H. L.	.. Rugby R.S. 11.12.39
West, A. S.	.. S.W. Reg. 17.2.40	Glanville, E. W. J.	.. Rugby R.S. to Leafield	To be fixed later
Flanagan, W. J. C.	.. E.-in-C.O. to Mid. Reg. 16.3.40	Whitfield, L.	.. Rugby R.S. to Leafield	To be fixed later
Mew, G. M.	.. L.T. Reg. to H.C. Reg. 17.2.40			

Name	Region	Date
<i>Submarine Cable Staff</i>		
Firmin, E. W. Cmdr. " Monarch " to Actg. Sub-Supt. E.-in-C.O. To be fixed later
Leech, W. H. Asst. Sub-Supt. E.-in-C.O. to Actg. Cmdr. " Ariel " To be fixed later
Wallis, R. H. J. Chief Officer " Monarch " to Actg. Cmdr. " Monarch " To be fixed later
Troops, A. E. 2nd Officer " Monarch " to Actg. Chief Officer " Ariel " To be fixed later
Oates, J. G. B. 3rd Officer " Monarch " to Actg. Chief Officer " Monarch " To be fixed later
Betson, J. P. F. 4th Officer " Monarch " to Actg. Chief Officer " Alert " To be fixed later
Elston, F. A. 3rd Officer " Alert " to Actg. 2nd Officer " Ariel " To be fixed later
Wood, R. 4th Officer " Alert " to Actg. 2nd Officer " Monarch " To be fixed later

Transfers

Name	Region	Date	Name	Region	Date
<i>Exec. Engr.</i>			<i>Prob. Asst. Engrs.—continued</i>		
Milton, G. P.	.. E.-in-C.O. to L.T. Reg. 1.2.40	Goodwin, A. E.	.. Bristol to E.-in-C.O. 1.2.40
<i>Asst. Engrs.</i>			Adams, W. E.	.. Preston to E.-in-C.O. 11.2.40
Sulston, W. J.	.. E.-in-C.O. to Scot. Reg. 26.11.39	Watt-Carter, D. E.	.. L.T. Reg. to E.-in-C.O. 11.2.40
Watson, L. R.	.. S. Mid. to L.T. Reg. 10.12.39	<i>Chief Insp.</i>		
Vann, C. J.	.. E.-in-C.O. to S.W. Reg. 14.1.40	Abel, G. P.	.. E.-in-C.O. to W. & B.C. Reg. 11.2.40
Mabe, W. S.	.. E.-in-C.O. to L.T. Reg. 21.1.40	Venus, W. A. H.	.. E.-in-C.O. to L.T. Reg. 25.2.40
Prickett, W.	.. E.-in-C.O. to S.W. Reg. 1.2.40	<i>Insp.</i>		
Matthews, W.	.. H.C. Reg. to L.T. Reg. 18.3.40	Fradley, W.	.. E.-in-C.O. to N.E. Reg. 1.2.40
Brooke, C. H.	.. E.-in-C.O. to L.T. Reg. To be fixed later	<i>Prob. Insp.</i>		
<i>Prob. Asst. Engrs.</i>			Cridlan, D. E.	.. L.T. Reg. to E.-in-C.O. 12.3.40
Burr, D. W.	.. Nott'm. to E.-in-C.O. 4.2.40	Quellin, A. A.	.. N.W. Reg. to E.-in-C.O. 4.2.40
Triffitt, L. A.	.. Lancaster to E.-in-C.O. 4.2.40	Harbord, C.	.. N.W. Reg. to E.-in-C.O. 10.3.40
Forty, A. J.	.. Oxford to E.-in-C.O. 4.2.40			

Retirements

Name	Region	Date	Name	Region	Date
<i>Exec. Engr.</i>			<i>Chief Insps.—continued</i>		
Dipple, H. W.	E.-in-C.O.	31.12.39	Elsley, W.	L.T. Reg.	31.12.39
<i>Chief Insps.</i>			Macdonald, N. M.	W. & B.C. Reg.	4.1.40
Green, W.	H.C. Reg.	18.11.39	<i>Insp.</i>		
Heathcote, A.	N.W. Reg.	31.12.39	Bowles, J. T...	Mid. Reg.	31.12.39
Dent, F.	N.E. Reg.	31.12.39			

Resignation

Name	Region	Date	Name	Region	Date
<i>Insp.</i>					
Weller, E. H.	H.C. Reg.	6.4.40			

Deaths

Name	Region	Date	Name	Region	Date
<i>A.S.E.</i>			<i>Chief Insps.</i>		
Wylie, T. O. K.	E.-in-C.O.	29.1.40	Rafferty, A.	L.T. Reg.	28.1.40
			Norman, W. H. B. D.	N.W. Reg.	1.3.40

CLERICAL GRADES

Promotions

Name	Region	Date	Name	Region	Date
<i>From E.O. to Staff Officer</i>			<i>From C.O. to E.O.—continued</i>		
Kennedy, W. E. H.,			Jeffreys, W. L.	E.-in-C.O.	12.1.40
M.C.	E.-in-C.O.	1.1.40	Brimmer, W. L.	E.-in-C.O.	4.12.39
Harrison, F. A.	E.-in-C.O.	12.1.40	Carstairs, G.	E.-in-C.O.	23.2.40
<i>From H.C.O. to Chief Clerk</i>			<i>From C.O. to H.C.O.</i>		
Schofield, W. H.	Reading Sub. Reg. to Bedford T.M.O.	8.1.40	Baker, C. P.	Manchester T.M.O. to Birmingham	3.12.39
<i>From C.O. to E.O.</i>			Roberts, F. J.	Shrewsbury	7.11.39
Binmore, H. P.	L.T.R. to E.-in-C.O.	17.5.39	Blower, H. O.	Coventry to Oxford T.M.O.	4.12.39
Page, E. A.	E.-in-C.O.	18.12.39	Farrand, S.	Preston T.M.O. to Birmingham	13.12.39
Weatherley, J. S.	E.-in-C.O.	18.12.39	Berry, E. A.	Peterboro' to Oxford T.M.O.	4.12.39
Winnett, M. S.	E.-in-C.O.	13.12.39	Ayers, R. J.	Norwich T.M.O.	17.11.39
Wright, E. K. (Miss)	E.-in-C.O.	1.1.40	Gander, A. J.	Bedford T.M.O.	8.1.40
Chappell, W. R.	E.-in-C.O.	12.1.40			

Appointment

Name	Region	Date	Name	Region	Date
<i>E.O.</i>					
Parker, J. A. T.	E.-in-C.O.	4.9.39			

Retirements

Name	Region	Date	Name	Region	Date
<i>Staff Officer</i>			<i>H.C.O.</i>		
Stephenson, W. H.	E.-in-C.O.	31.12.39	Brown, R. H.	Preston	30.11.39

Death

Name	Region	Date	Name	Region	Date
<i>E.O.</i>					
Smith, H. J.	E.-in-C.O.	29.1.40			

Book Reviews

"Telephony: Supplement to Volume II." T. E. Herbert, A.M.I.E.E., and W. S. Procter, A.M.I.E.E. 97 pp. 83 ill. Pitman. 3s. 6d.

It is inevitable that a work of the magnitude of that written by Messrs. Herbert and Procter concerning a subject which is developing as rapidly as telephony, should be out of date in some respects before it is published. The authors made an effort to catch up with the latest developments by the inclusion of two appendices in Volume II dealing with the 2,000-type selector mechanism and float power plants. The present work is a further appendix issued in the form of a separate supplement. It deals almost exclusively with 2,000-type selector circuits commencing with a 20-page general section dealing with group and final selectors, followed by approximately 70 pages devoted to a detailed study of the circuits of U.A.X.'s Nos. 13 and 14. A final section of 3 pages describes the inductor tone generator. Director and non-director circuits, other than those relating to group and final selectors, are not included.

The style and layout of the book is identical with that of the main work. Many of the circuits are admirably dissected and the various facilities dealt with separately. It is, however, a supplement dealing purely with circuit descriptions; 90 per cent. of the diagrams are circuits, and there is not a single photograph included. From this it will be appreciated that

the supplement is not complete in itself, and must be read in conjunction with Volume II of the main work if a comprehensive picture of the equipment, its facilities and methods of operation is to be obtained.

The symbols used are claimed to be in accordance with the latest recommendations of the British Standards Institution and therefore differ in some respects from those used in the parent volume. It is noticed, however, that three different symbols have been used to represent a two-motion selector on circuit diagrams, and that on several diagrams the same symbol is used to represent both uniselectors and two-motion switches. This is, however, one of the few blemishes noticed. H. L.

"Tables for Converting Rectangular to Polar Co-Ordinates." J. C. P. Miller. 16 pp. Scientific Computing Service. 2s.

The main object of these tables is to facilitate the conversion of rectangular co-ordinates (x, y) to polar co-ordinates (r, θ) by use of the relations $r^2 = x^2 + y^2$ and $\tan \theta = y/x$.

The engineer will find the tables useful for the evaluation of impedance and phase angle from resistance and reactance. The evaluation of the magnitude and direction of a vector from rectangular components and the conversion of complex numbers from the form $x + jy$ to the form $r \exp(j\theta)$ are further applications.

H. J. J.

BOARD OF EDITORS

A. J. GILL, B.Sc., M.I.E.E., M.I.R.E., Chairman.
F. E. NANCARROW, A.R.C.Sc., M.I.E.E.
P. B. FROST, B.Sc., M.I.E.E.
A. H. MUMFORD, B.Sc.(ENG.), A.M.I.E.E.
C. W. BROWN, A.M.I.E.E.
R. E. JONES, M.Sc., A.M.I.E.E.
H. LEIGH, B.Sc.(ENG.), A.M.I.E.E., Acting Managing Editor.

Copyright

The entire contents of this JOURNAL are covered by general copyright, and special permission is necessary for reprinting long extracts, but Editors are welcome to use not more than one-third of any article, provided credit is given at the beginning or end thus: "From the *Post Office Electrical Engineers' Journal*."

The Board of Editors is not responsible for the statements made or the opinions expressed in any of the articles in this JOURNAL, unless such statement is made specifically by the Board.

Communications

All Communications should be addressed to the Managing Editor, *P.O.E.E. Journal*, Engineer-in-Chief's Office, Alder House, Aldersgate Street, London, E.C.1. Telephone: HEADquarters 1234. Remittances should be made payable to "*The P.O.E.E. Journal*" and should be crossed "& Co."

Binding Cases

Cases for binding are available, and may be obtained from the Local Agents for 1s. 9d. Subscribers can have their copies of Volumes bound, at a cost of 3s., by sending the complete set of parts to the Local Agents or to the *P.O.E.E. Journal*, Engineer-in-Chief's Office, Alder House, Aldersgate Street, London, E.C.1. Orders for binding for Vols. 1-19 should indicate whether the original binding case with black lettering, or the later pattern with gold, is required. Cases with gold lettering are the only type stocked from Vol. 20 onwards.

Back Numbers

The price of the JOURNAL, which is published quarterly, is 1s. (1s. 3d. post free) per copy, or 5s. per annum post free. Back numbers can be supplied, subject to availability of stocks, at 1s. each (1s. 3d. post free). Orders for back numbers may be sent to the Local Agents or to the Publishers.

Advertisements

All communications relating to space reservations should be addressed to the Advertisement Editor, *P.O.E.E. Journal*, Alder House, Aldersgate Street, London, E.C.1. Communications regarding advertisement copy, proofs, etc., should be addressed to the Publishers, Messrs. Birch & Whittington (Prop. Dorling & Co. [Epsom], Ltd.), 49 Upper High Street, Epsom, Surrey.

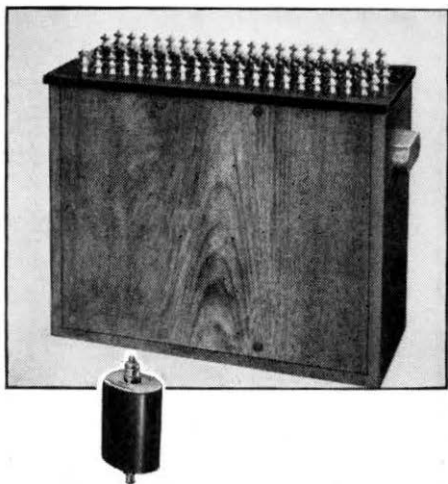
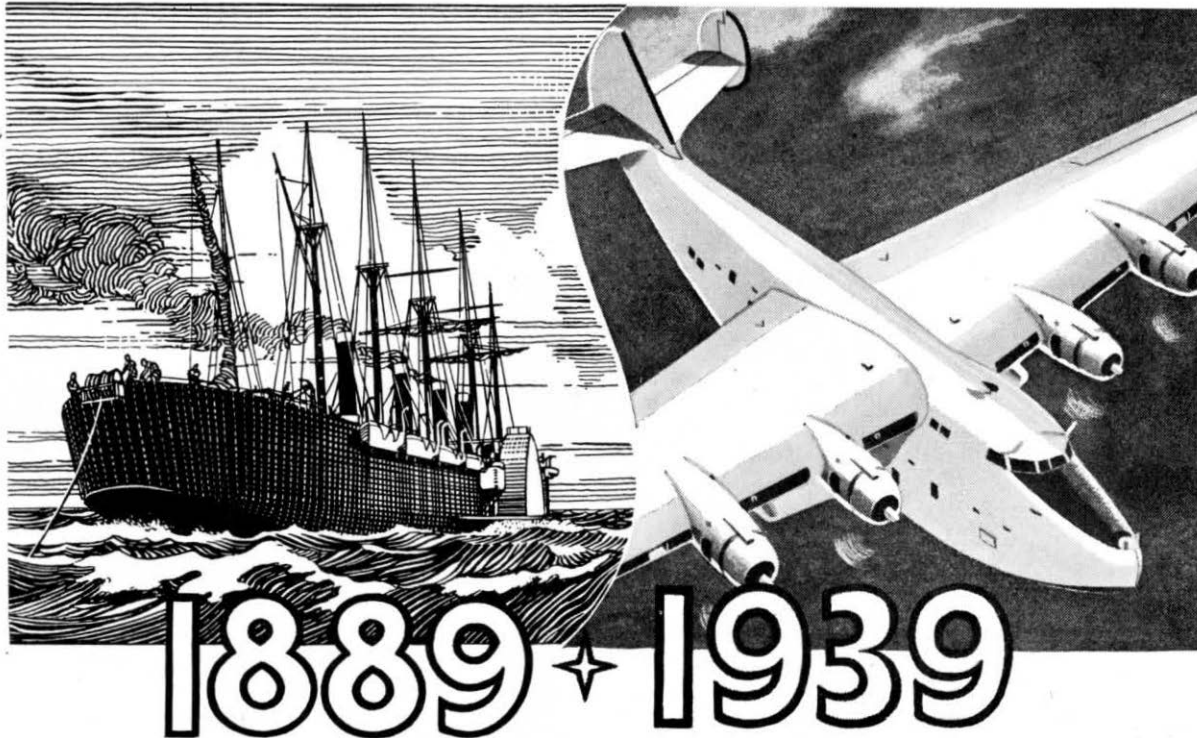

MUIRHEAD

THESE TWO MUIRHEAD CONDENSERS MAKE history. The one above is retiring after 50 years' faithful service in a circuit where high insulation is essential. It is being pensioned off because 2 of its 40 sections are now below standard, though the remainder still have an insulation resistance of 17,000 megohms per micro-farad at 20° C. ! The lower condenser, specially designed for use in aircraft flying alternately in arctic and tropical conditions, has a different form but the same character. It is just starting on its career, and we have no fear of the story which will be written about *this* condenser 50 years from now.

MUIRHEAD AND COMPANY LIMITED • ELMERS END, BECKENHAM, KENT • TELEPHONE: BECKENHAM 0041-0042

FOR OVER 60 YEARS DESIGNERS & MAKERS OF PRECISION INSTRUMENTS

C. R. Casson 22

CAPCO

REGISTERED TRADE MARK

Quartz Cutting Machine

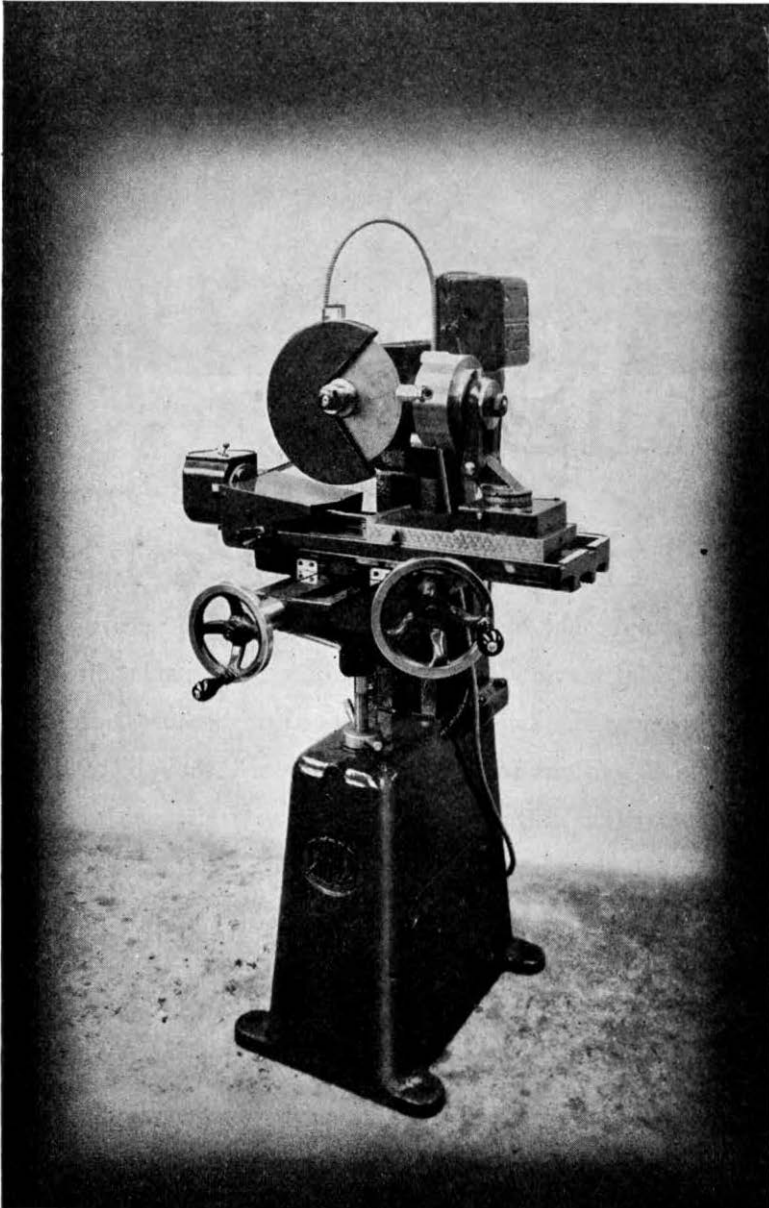

Designers and Manufacturers of Capco Sound-on-Film recorders and equipment. Patentees and Manufacturers of Capco Enamelled Wire cleaning machines.

Illustration shows latest Model of the Quartz Cutting Machine developed and designed in collaboration with engineers of the Radio Branch of the Post Office.

Similar machines have been supplied to the Post Office and to the leading Telephone and Radio Manufacturers.

Standard and heavy duty cutting machines with high rates of cutting to accuracies of .001 in.

Fixtures to hold any shape of crystal can be supplied.

Heavy Duty Machine can now be supplied with nine rates automatic feed through specially designed gear box, sensitive instantaneous stop through specially designed clutch.

Acknowledged to be the finest machines of their kind for this class of work.

Manufacturers :

CAPLIN

ENGINEERING CO. LTD.

Precision Engineers

BEACONSFIELD RD., WILLESDEN
LONDON, N.W.10

Telephone :
WILlesden 0692.

Cables :
Caplinko, London.

ESTABLISHED 1918

SERVICE

such as this proves

Westinghouse

RELIABILITY



1. Installed in March, 1929, at Victoria and Exchange Station, Manchester, L.M. & S., these Westinghouse Metal Rectifiers have been in constant use ever since, operating D.C. point machines direct from a 3-phase A.C. supply. Two rectifiers are employed, each having a capacity of 3 K.W.

2. Two rectifier equipments used for trickle charging batteries for operation of electric point machines, installed at Brighton Station, Southern Railway. These have been in service for over seven years.

3. A three-bank rectifier set for direct operation of 110-volt D.C. point machines, brought into service at St. Enoch Station, Glasgow, L.M. & S., in 1933.

4. Rectifiers for charging H.T. and L.T. Batteries at the G.P.O. Radio Telephony Receiving Station, Baldock, Herts. Output 200 volts 3 amperes (H.T.) and 20 volts 25 amperes (L.T.). These rectifiers have given satisfactory service over a period of more than ten years.

Westinghouse Metal Rectifiers require no renewals or attention. They contain no glass bulbs, filaments, or other fragile parts, and their robust all-metal construction enables them to maintain their reliability and efficiency under all conditions of service.

Write for descriptive pamphlet No. 11 to Department P.O.E.J.
WESTINGHOUSE BRAKE & SIGNAL CO., LTD.
Pew Hill House, Chippenham, Wilts.

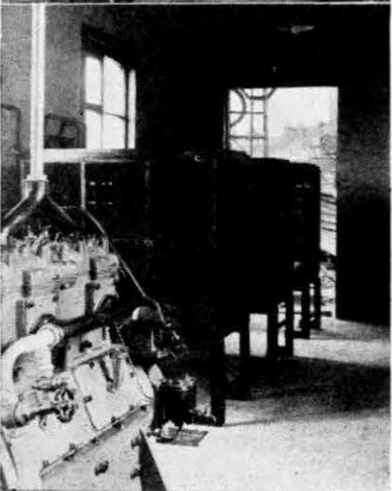
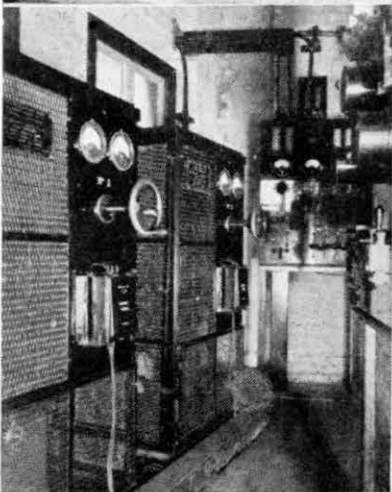

The New Star of the Telephone World

THE new Ericsson Automatic Telephone No. 1002 shown here has a casework of black moulded bakelite in a modern, distinctive and pleasing design. It incorporates a form of cradle or micro-telephone rest which is not readily damaged should the instrument get violently knocked or fall to the ground.

The whole of the interior apparatus which is mounted on a frame can be removed as a unit, the base plate which incorporates a useful sliding tray fitment being first removed. Dimensions, 6 by $9\frac{1}{2}$ by $8\frac{1}{2}$ inches ; weight, 6 lbs.

NOW AVAILABLE TO P.O. SUBSCRIBERS

Full particulars from makers :

ERICSSON TELEPHONES LTD.

HEAD OFFICE : 22 LINCOLN'S INN FIELDS, LONDON, W.C.2.

Works : Beeston, Notts.

(Telephone : HOLborn 6936)



CREATED BY

Ericsson

TELEPHONES LTD.



NO FUEL SHORTAGE FOR 'ELECTRICS'

THERE is no restriction on 'Electrics' nor on the 'fuel' they use. This gives them another overwhelming advantage for short distance transport. Furthermore anyone with road sense learns to drive an 'electric' in a very little while.

To secure maximum economy and reliability for 'electrics' they must be equipped with strongly built batteries that sustain their

voltage under all conditions throughout a long and trouble-free life.

Ever since 'electrics' first appeared the Chloride Company have put their full resources behind perfecting batteries for this purpose—and Chloride are the biggest battery makers in the British Empire. They also have the most effective after-sales service organisation in the country.

Exide-Ironclad BATTERIES

Still keep going
when the rest
have stopped'

* For further details about electric vehicles and batteries write to The Chloride Electrical Storage Co., Ltd., Battery Traction Dept., Exide Works, Clifton Junction, near Manchester. London Office, 137, Victoria St., S.W.1.



G.E.C.

VIEW OF BUILDING IN WHICH IS HOUSED THE FIRST PUBLIC AUTOMATIC TELEPHONE EXCHANGE IN THE DUTCH EAST INDIES, RECENTLY SUPPLIED AND INSTALLED BY THE GENERAL ELECTRIC COMPANY, LTD.

IN CONFORMITY WITH THE NATIONAL POLICY OF INCREASING THE VOLUME OF EXPORTS THE GENERAL ELECTRIC COMPANY TELEPHONE WORKS WISHES TO ASSURE ITS CLIENTS OVERSEAS THAT, NOTWITHSTANDING PRESENT CONDITIONS, ITS PRODUCTION OF TELEPHONE EQUIPMENT FOR EXPORT IS BEING FULLY MAINTAINED. FACTORY CAPACITY HAS BEEN RESERVED FOR THIS PURPOSE THUS ENSURING NORMAL DELIVERY TIMES.

THE GENERAL ELECTRIC CO. LTD. OF ENGLAND

TELEPHONE WORKS

COVENTRY

ENGLAND

Coventry 4111 (10 lines)

Springjack, Coventry

HEAD OFFICE : MAGNET HOUSE, KINGSWAY, LONDON, W.C.2

AUTHORITATIVE CORRESPONDENCE TRAINING for ENGINEERING QUALIFICATIONS

- POST OFFICE ENGINEERING
- A.M.Inst.C.E., A.M.I.E.E., A.F.R.Ae.S., B.Sc.(Eng.), C. & G., etc.

25 FIRST PLACES and INSTITUTION PRIZES

and HUNDREDS of PASSES have been gained by T.I.G.B. students in the above examinations. The T.I.G.B. Guarantees Training until Successful for the one fee.

Write to-day for "The Engineer's Guide to Success" — Free — which alone gives the Regulations for Engineering Qualifications and contains the world's widest choice of engineering courses — over 200 — including Electrical Engineering, Telephony, Telephonic Transmission, Telegraphy, Radio Engineering, Wireless and High Frequency Engineering, Sound Reproduction, Television, etc. Mention branch, post or qualification that interests you.



THE TECHNOLOGICAL INSTITUTE OF GREAT BRITAIN

115 Temple Bar House, London, E.C.4
FOUNDED 1917 20,000 SUCCESSES

Austinlite

AUTOMATIC STANDBY PLANT

Recently completed AUSTIN-LITE STANDBY PLANTS range in size from a 200 k.w. Automatic Plant for a large Municipal Power Station to a 2½ k.w. Plant for an A.R.P. Shelter.

Whatever the size and purpose of the plant the same stringent test conditions are applied.

AUSTINLITE LTD.

Proprietors:
CHANCE BROTHERS & CO. LIMITED
LIGHTHOUSE WORKS, SMETHWICK

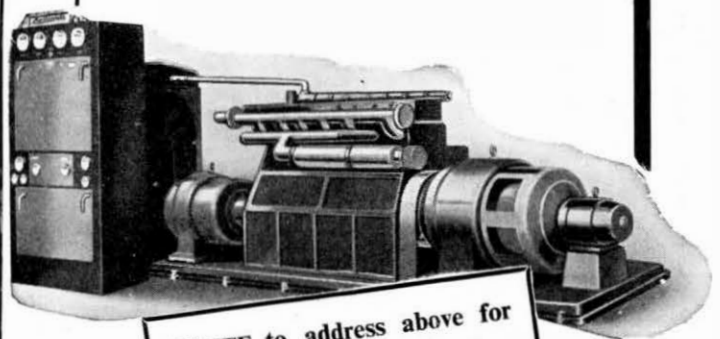

WRITE to address above for full details and specifications covering your requirements.

Sullivan-Griffiths
**DIRECT READING Universal
 PRECISION INDUCTANCE BRIDGE**

Range $1\mu\text{H}$ to 100H .

Direct Reading Accuracy better than 0.1% or $0.1\mu\text{H}$.

Negligible frequency error.

Direct Reading Measurements of
RESISTANCE 0.01Ω to $10\text{M}\Omega$

and by means of simple attachments

Direct Reading Measurements of
 both Inductance and Losses of

IRON CORED INDUCTANCES
 with superposed D.C. up to 2 Amperes

and

Direct Reading Measurements of
CAPACITANCE $10\mu\text{F}$ to $1\mu\text{F}$.

Both D.C. and A.C. resistance tests may be made
 on the one bridge without handling the coil.

Accuracy is unaffected by temperature owing to
 temperature compensated standard inductances.

List No. A.C.1100

H. W. SULLIVAN LIMITED

LONDON, S.E.15

Telephones :
 NEW CROSS 3225 (P.B.X.)

Telegrams :
 STANDELECT PECK LONDON.

"Sullivan" guarantees accuracy



EDISWAN

TELEPHONE LINE PROTECTOR PANELS

EDISWAN-SHOTTER-GREETHAM PATENT

(British Patent No. 353924)

**for the protection of telephone systems
 against surges induced by faults on
 neighbouring power lines**

Of the difficulties attendant upon the employment of overhead systems one of the most serious is to ensure uninterrupted working of the telephone system, by providing adequate protection against induced surges caused by switching or line faults in adjacent power lines or by lightning.

The Ediswan Patent Protectors provide the solution. They are inert at the normal working pressure of the telephone line, they keep the voltage on the line down to a pre-determined figure by providing a path of low resistance to earth whereby the surge is cleared and they again become inert immediately the surge is cleared.

They ensure simultaneous discharge of both lines and are capable of clearing heavy discharges without detriment to the system or the protector.

**Ediswan Telephone Line Protectors have now been in
 use by Supply Companies for many years.**

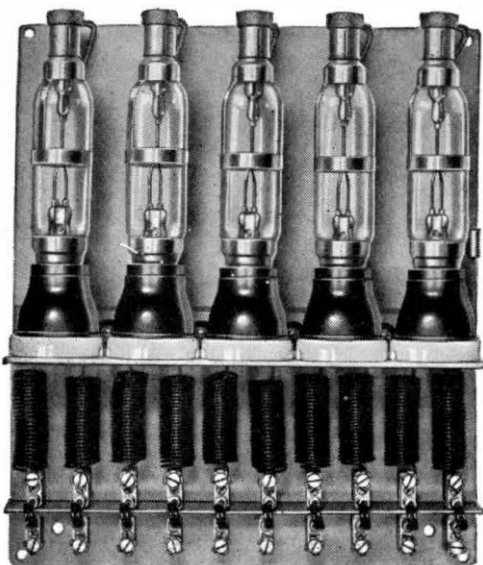

5-circuit panel for overhead lines incorporating choke coils,
 spark gaps, etc.

THE EDISON SWAN ELECTRIC CO. LTD.,  155 CHARING CROSS ROAD, LONDON, W.C.2

INDEX TO ADVERTISERS

Alton Battery Co., Ltd., The	viii
Austinlite, Ltd.	xviii
Automatic Coil Winder & Electrical Equipment Co., Ltd.	iii
Automatic Telephone & Electric Co., Ltd. ..	iv & v
Bennett College	ix
Caplin Engineering Co., Ltd.	xii
Edison Swan Electric Co., Ltd., The	xix
Elliott Bros. (London), Ltd.	xxiii
Ericsson Telephones, Ltd.	xiv & xv
Evershed & Vignoles, Ltd.	xxii
Exide	xvi
Ferranti, Ltd.	xxi
General Electric Co., Ltd., The	ii & xvii
Hall Telephone Accessories (1928), Ltd.	xxi
International Correspondence Schools, Ltd.	xxi
Muirhead & Co., Ltd.	xi
Pirelli-General Cable Works, Ltd.	xxiv
Siemens Brothers & Co., Ltd.	vi & vii
Smith, Frederick, & Co.	xxiii
Standard Telephones & Cables, Ltd.	x
Sullivan, H. W., Ltd.	xix
Technological Institute of Great Britain, The	xviii
Telephony Publishing Corporation	xx
Turner, Ernest	xx
Westinghouse Brake & Signal Co., Ltd.	xiii

For New Telephone Developments—Technical, Plant, Commercial, Traffic, as well as late news affecting use of telephones—**READ**

TELEPHONY!

The weekly journal of the telephone industry. In these changing times the best investment a telephone man can make is to invest in himself. Competent men—the men who are well informed about their particular work and the business as well—are the ones who win promotion. "TELEPHONY" covers every department of the telephone industry. It is informative, factual, inspirational; it publishes the latest developments, tells the approved telephone practices and current telephone news.

READ TELEPHONY!

Subscription price, \$5.00 per year; 52 issues. Published since 1901.

Address: Odhams Press, Ltd., Technical Book Dept., 85 Long Acre, London, W.C.2 (Telephone: Temple Bar 2448) for a sample copy of TELEPHONY, or write direct to:

TELEPHONY PUBLISHING CORPN.
608 S. Dearborn Street, Chicago, Ill., U.S.A.

TURNER DIFFERENTIAL MILLIAMMETERS G.P.O. No. 17 & No. 18

Meet the most exacting demands for balancing currents in multiplex telegraph circuits. —A quality product of outstanding merit—

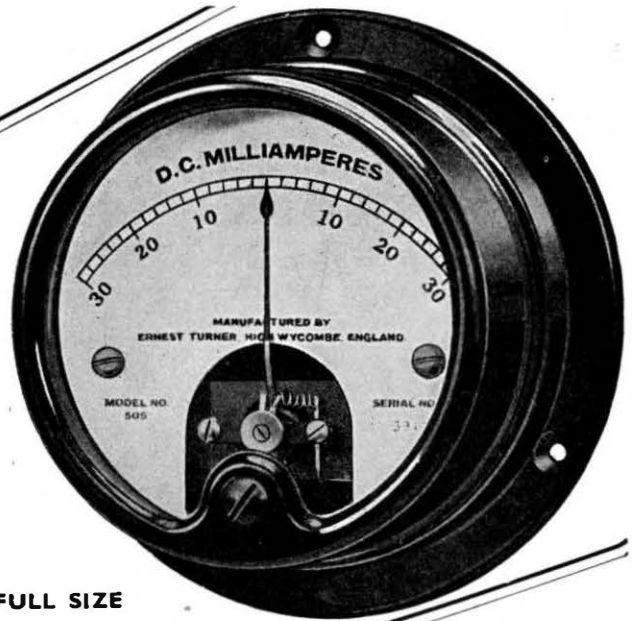

FULL SIZE

Also manufacturers of G.P.O. Detector No. 4, and a comprehensive line of instruments for precision electrical measurements.

ERNEST TURNER ELECTRICAL INSTRUMENTS, Ltd.

**CHILTERN WORKS,
49-73 TOTTERIDGE AVENUE,
HIGH WYCOMBE,**

BUCKS, ENGLAND

Telephone: High Wycombe 1301, 1302.
Telegrams: Gorgeous, High Wycombe.



Spare-Time Training by Post in all Electrical Subjects

The International Correspondence Schools, largest and most successful institution of its kind in the world, offers thoroughly sound Courses of Instruction to cover the following Examinations :

GRADUATESHIP, I.E.E.

**CITY AND GUILDS ELECTRICAL ENGINEERING PRACTICE.
ELECTRIC INSTALLATION AND TELECOMMUNICATIONS.
G.P.O. PROBATIONARY ASSISTANT ENGINEER (LIMITED).
G.P.O. PROBATIONARY INSPECTOR (ENGINEERING DEPT.).
ASSISTANT TRAFFIC SUPERINTENDENT, TELEPHONE SERVICE.**

**P.M.G. CERTIFICATE FOR WIRELESS OPERATORS.
PROVISIONAL CERTIFICATE IN RADIO TELEPHONY AND TELEGRAPHY FOR AIRCRAFT.**

INSTITUTE OF WIRELESS TECHNOLOGY.

Other Courses meet the requirements of all who desire to qualify for responsible positions in Electric Power, Light and Traction Stations. Equally successful is our instruction for Telegraph and Telephone Engineers, Telegraphists and Telephonists, Radio Engineers, Radio Servicemen, and those who wish to study Television.

Instruction is by correspondence from textbooks specially prepared by many experts in tuition by post.

WRITE FOR OUR SPECIAL BOOKLET

stating Examination or Subject in which you are interested.

**INTERNATIONAL
CORRESPONDENCE SCHOOLS LTD.**

DEPT. 108

International Buildings, Kingsway, London, W.C.2



Hall Telephone Accessories (1928) Limited

Suppliers to the British Post Office, Air Ministry, Admiralty, War Office and Foreign Government Departments.

Manufacturers of prepayment telephone multi-coin collectors, gas leak indicators, precision instruments, automatic stamp selling and ticket selling machines, automatic slot machines and fire alarm apparatus.

Registered

*Office & Works: 70, DUDDEN HILL LANE,
WILLESDEN,*

Tel. WILLESDEN 5141/2/3. LONDON, N.W.10

Also GUEST WORKS, DOWLAIS, STH. WALES

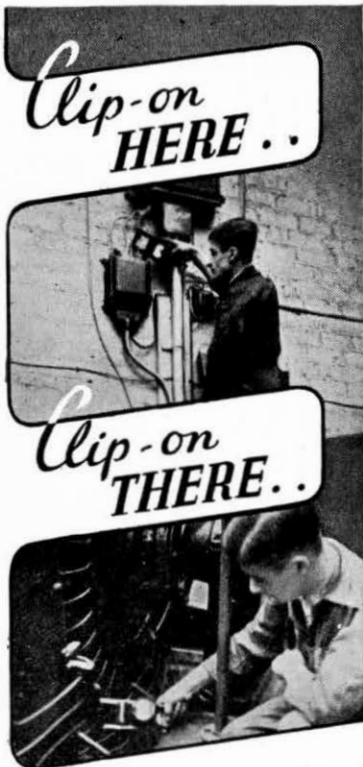

*Clip-on
almost
EVERYWHERE*



The range of the instrument is changed by a half turn of the switch.

Comprehensive Ranges	Available :
0-100-500	0-7.5-75 0-20-100
0-100-1000	0-10-50 0-25-150
0-200-1000	0-15-75 0-50-250
0-300-1500	

Quick Change to New Range

Write for List IN.11.

**FOR CHECKING CURRENT IN
BUSBARS, FUSES & CABLES**

FERRANTI
DUAL RANGE
Clip-on **AMMETER**

FERRANTI LTD., HOLLINWOOD, LANCS.
London Office: Bush House, Aldwych, W.C.2.

STANDARD WITH THE BRITISH POST OFFICE

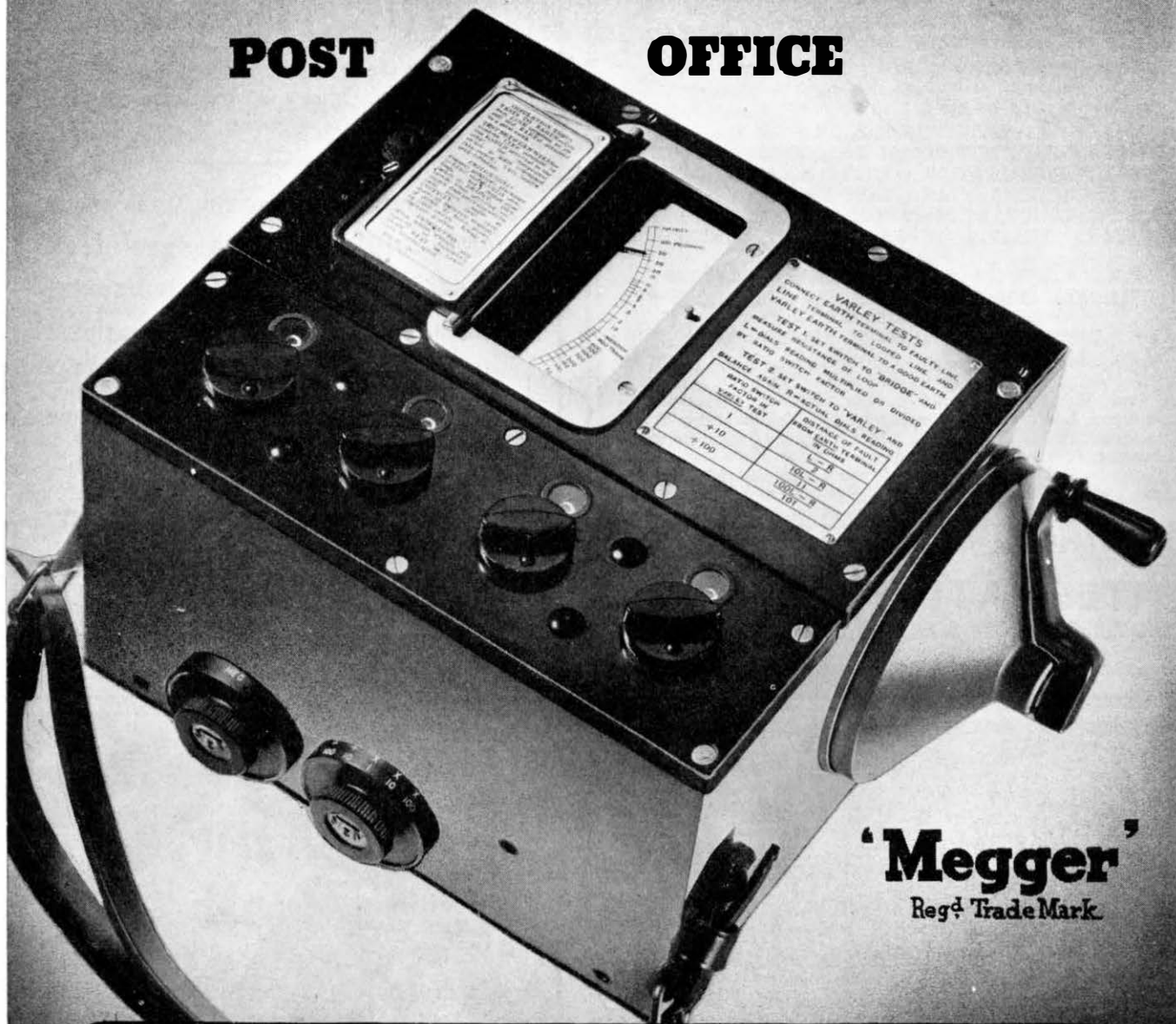

'Megger'
Regd TradeMark

THE BRIDGE-MEG TESTING SET used by the British Post Office is a portable, self-contained instrument combining the functions of an Insulation Tester and a Wheatstone Bridge; it can be used for fault location by the Varley Loop method. Facilities can also be provided whereby, with the use of an external galvanometer and resistance box, the instrument may be used for making Murray Loop tests. Insulation range 100 megohms at 500 volts. Bridge range 0.01 to 999,900 ohms. Size $7 \times 8\frac{3}{4} \times 12$ ins. Weight $12\frac{3}{4}$ lbs. Mains operated instruments are also supplied to the British Post Office. Ask for list X 267.

EVERSHED & VIGNOLES LTD., CHISWICK, LONDON, W.4
TELEPHONE: CHISWICK 1370 * TELEGRAMS: "MEGGER" CHISK, LONDON

For **BARE COPPER** *Electrical Connections*

Use
ANACOS
REGD.



**COPPER STRIP · COPPER BUSBARS
ROUND, SQUARE & HEXAGONAL BARS
COMMUTATOR BARS · LINE WIRES
TAPES & BINDERS · EARTH RODS**

PRODUCED BY SPECIALISTS IN COPPER AND ALLOY CONDUCTORS FOR 75 YEARS

TELEPHONE
BLACKFRIARS
8701 (8 lines)

FREDERICK SMITH & COMPANY
(INCORPORATED IN THE LONDON ELECTRIC WIRE COMPANY AND SMITHS LIMITED)
ANACONDA WORKS, SALFORD, 3, LANCS.

TELEGRAMS
"ANACONDA"
MANCHESTER

Differential Moving Coil **MILLIAMMETERS**

For Telegraph Circuits



T. 1098. WALL MOUNTING TYPE.

British
Instruments
for
British
Industries

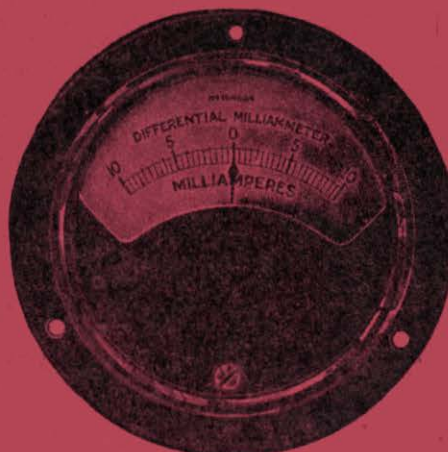

T. 1089. PANEL MOUNTING TYPE.



T. 1097. TABLE MOUNTING TYPE.

**TABLE, WALL AND PANEL
MOUNTING TYPES**

INVALUABLE as line Milliammeters
on Differential Duplex, Sub-Audio
Frequency and many other Telegraph Systems, also for testing
purposes in connection with Land Lines and Radio Communication.

Particulars will be sent on request.

ELLIOTT BROTHERS (London) LTD., Century Works, Lewisham, S.E.13

in association with

SIEMENS BROTHERS & COMPANY, LIMITED, Woolwich, London, S.E.18

Telephone :
Tideway 3232

Telephone :
Woolwich 2020

OVER **2½ MILLION** YARDS

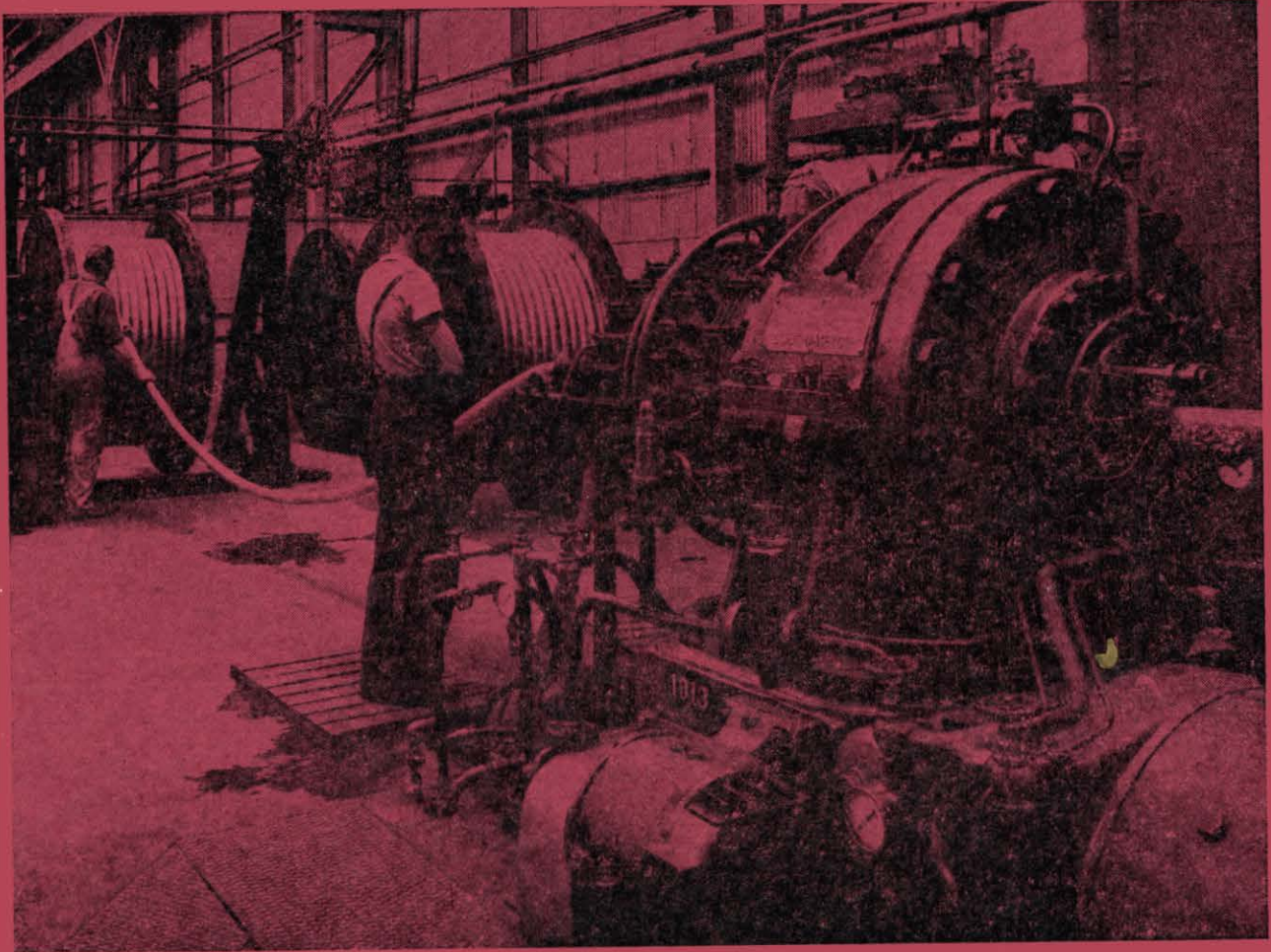

OF AIR SPACE TELEPHONE AND
SUPERTENSION CABLES HAVE
NOW BEEN SHEATHED ON THE
PIRELLI-GENERAL CONTINUOUS
LEAD EXTRUDING MACHINES.

TELEPHONE:
SOUTHAMPTON
2141 (5 lines).

PIRELLI-GENERAL
CABLE WORKS, Ltd., SOUTHAMPTON.

TELEGRAMS
"PIGEKAYBEL"
SOUTHAMPTON

Proprietors: PIRELLI, Ltd., and THE GENERAL ELECTRIC CO., LTD.