

# THE POST OFFICE ELECTRICAL ENGINEERS' JOURNAL

**VOL. 32**

**JANUARY, 1940**

**PART 4**

## CONTENTS

	PAGE
NEW DEVELOPMENTS IN POWER CIRCUIT GUARDING— R. E. Rimes, B.Sc. . . . .	219
THE ESSENTIAL CHARACTERISTICS OF TELEVISION CIRCUITS—R. F. J. Jarvis, Ph.D., and E. C. H. Seaman, B.Sc. . . . .	224
MELBOURNE CITY WEST EXCHANGE—W. Cornell and B. Draper . . . . .	237
ADDITION AND SUBTRACTION LOGARITHMS—F. Addey, B.Sc., F.R.A.S., M.I.E.E. . . . .	244
THE OPERATION AND UTILISATION OF ECHO- SUPPRESSORS—R. E. Jones, M.Sc., A.M.I.E.E. . . . .	247
BALDOCK RADIO-TELEPHONE RECEIVING STATION— G. T. Evans and J. E. Luckhurst . . . . .	256
STREAM-DAMMING—A. T. Soons . . . . .	261
NOTES AND COMMENTS . . . . .	264
JUNIOR SECTION NOTES . . . . .	264
REGIONAL NOTES . . . . .	265
BOOK REVIEW . . . . .	267
STAFF CHANGES . . . . .	268
INDEX TO VOLUME 32 . . . . .	271

Price 1/- net

**THE INSTITUTION OF POST OFFICE ELECTRICAL ENGINEERS**

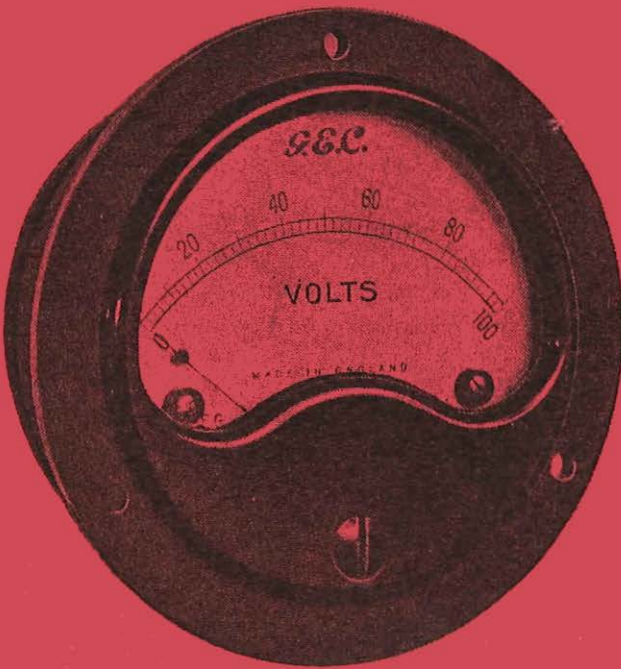

# G.E.C.

## ACCURATE MEASUREMENT

Accurate measurement, the essential of progress, necessitates the use of good instruments, and nowhere is this more important than in radio.

Good instruments can be designed and produced consistently only as the result of great experience in experiment and research extending over many years.

Salford Electrical Instruments Ltd. have been making first quality instruments for half a century, and their products are to be seen in constant use in Power Houses, Test Rooms and Laboratories all over the world.

Instruments in sizes from 2" upwards are available for almost every electrical measurement. The 2½" flush or projecting types are specially suited for radio purposes, and may be supplied as:—Milliammeters, Microammeters, Ammeters, and Voltmeters, D.C. and A.C.

Portable types are also made in most of these ranges. For H.F. measurements a range of Valve Voltmeters is available.

*Please write for descriptive list S.27, and state particular instruments in which you are interested.*



**SALFORD ELECTRICAL INSTRUMENTS LTD.**  
**PEEL WORKS, SALFORD, 3.**

Telephones : BLAckfriars 8888 (3 lines) Telegrams and Cables : " SPARKLESS, MANCHESTER "

PROPRIETORS: THE GENERAL ELECTRIC CO., LTD., OF ENGLAND

# SIMPLIFIED SERVICING MAINTENANCE & FAULT FINDING

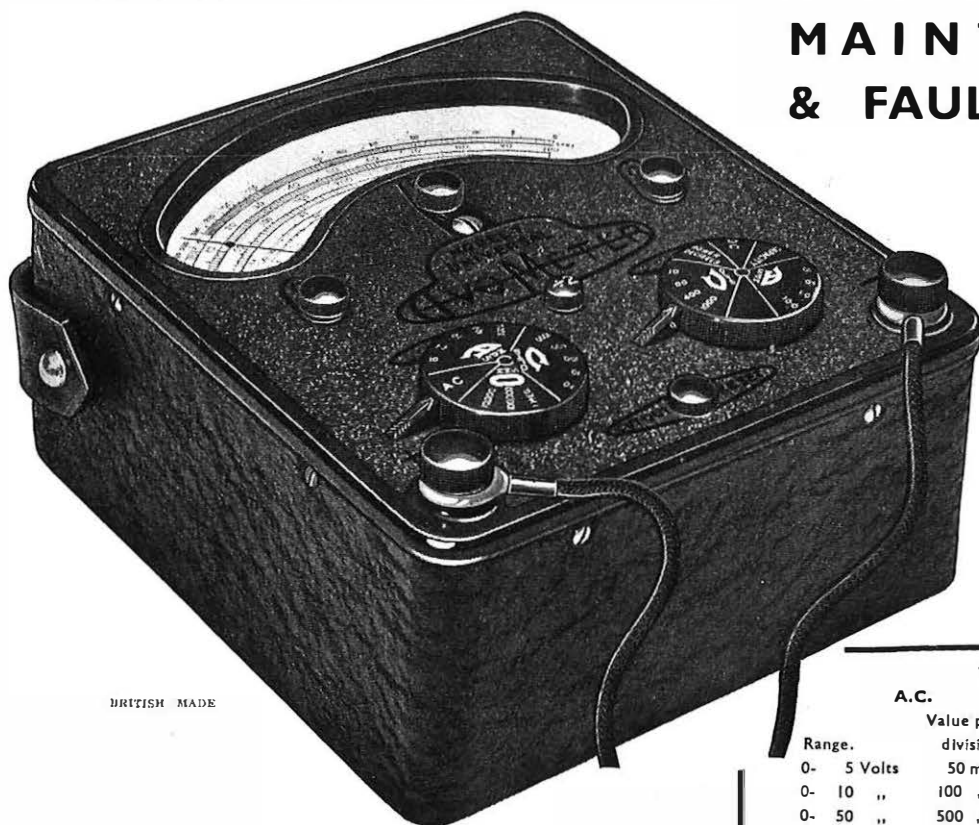

BRITISH MADE

**DESIGNED** by technicians who have made a special study of the service and maintenance engineers' problems, the Model 7 Universal AvoMeter is acknowledged throughout the world as the one indispensable combination testing instrument. A single meter, yet at the touch of two simple switches it provides for any one of the 46 ranges of measurements for testing and tracing all electrical faults.

Entirely self-contained, the Model 7 Universal AvoMeter is essentially portable and, above all, simple to use. It is dead-beat in action, has a 5-inch hand-calibrated scale with anti-parallax mirror, and conforms to B.S. 1st Grade accuracy requirements. It is fully protected by an automatic cut-out against damage through overload.

#### Also available :

Model 7 Resistance range Extension Unit (for measurements down to 1/100th. ohm.)	36-range Universal AvoMeter 22-range D.C. AvoMeter Leather Carrying Case
--	--

• Write for fully descriptive pamphlet.

Sole Proprietors and Manufacturers :

The Automatic Coil Winder & Electrical Equipment Co., Ltd.,  
Winder House, Douglas Street, London, S.W.1. Telephone: Victoria 3404/7

**46 Ranges**  
of  
Direct  
Readings

VOLTAGE			
A.C.		D.C.	
Range.	Value per division	Range.	Value per division
0- 5 Volts	50 mV.	0- 50 mV	0.5 mV
0- 10 "	100 "	0- 100 mV	1 "
0- 50 "	500 "	0- 500 mV	5 "
0- 100 "	1 Volt	0- 1 Volt	10 "
0- 200 "	2 "	0- 5 "	50 "
0- 400 "	4 "	0- 10 "	100 "
0- 500 "	5 "	0- 50 "	500 "
0-1,000 "	10 "	0- 100 "	1 Volt
		0- 200 "	2 "
		0- 400 "	4 "
		0- 500 "	5 "
		0-1,000 "	10 "
CURRENT			
A.C.		D.C.	
Range.	Value per division	Range	Value per division
0- 5 mA	50 $\mu$ A	0- 1 mA	10 $\mu$ A
0- 10 "	100 "	0- 2 "	20 "
0- 50 "	500 "	0- 5 "	50 "
0-100 "	1 mA	0- 10 "	100 "
0-500 "	5 "	0- 50 "	500 "
0- 1 Amp.	10 "	0-100 "	1 mA
0- 5 "	50 "	0-500 "	5 "
0- 10 "	100 "	0- 1 Amp.	10 "
		0- 5 "	50 "
		0- 10 "	100 "
RESISTANCE			
Range.	First indication.		
0-10,000 ohms	0.5 ohms	} using internal 1½-volt cell.	
0-100,000 "	5 "	} using internal 9-volt battery.	
0- 1 megohm	50 "	} using external source of	
0-10 "	500 "	} A.C. or D.C. voltage.	
0-40 "	2,000 "		
CAPACITY		POWER	
0 to 20 mFd.		in 4,000 $\Omega$	
First Indication		Internal resistance	
0.01 mFd.		0 to 4 watts	
		First indication	
		1 mW	
DECIBELS			
reference level			
50 mW			
		-10 Db. to	
		+15Db.	

The 46-RANGE UNIVERSAL  
**AVOMETER**  
Regd. Trade Mark  
Electrical Measuring Instrument *Model 7*

---



---

**capco**

---



---

REGISTERED TRADE MARK

# Quartz Cutting Machine

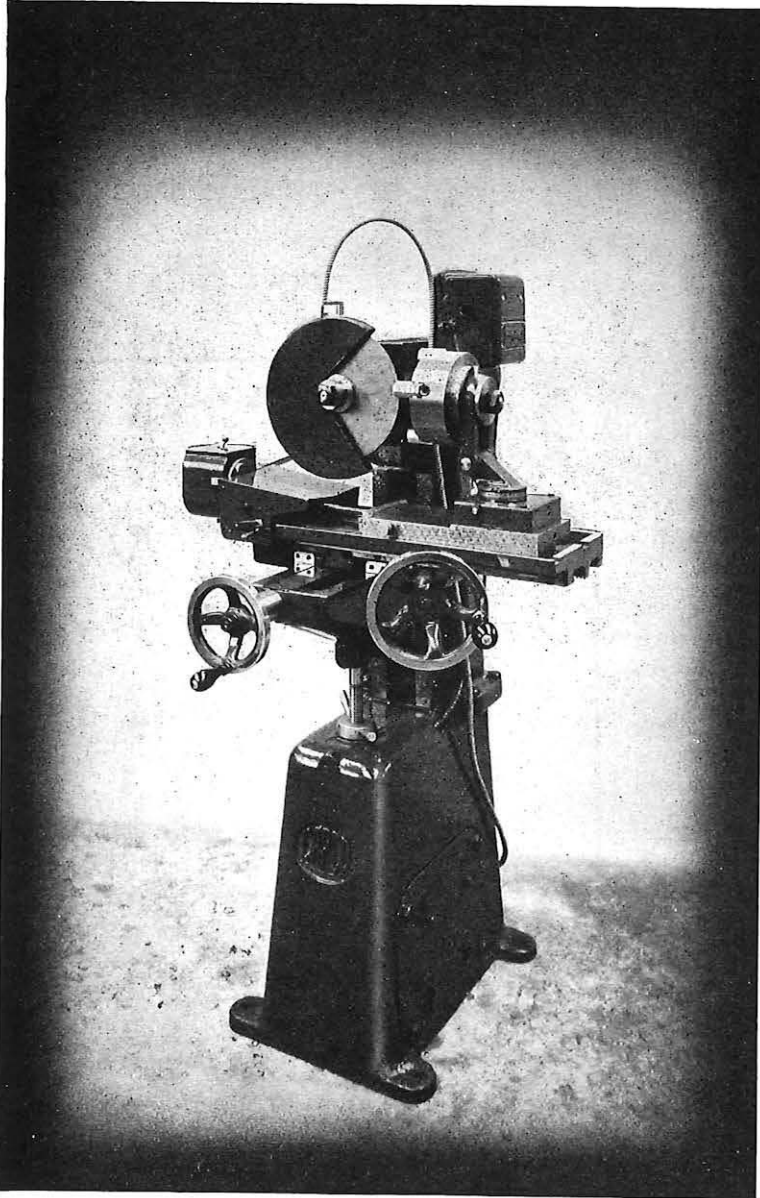

*Designers and Manufacturers of Capco Sound-on-Film recorders and equipment. Patentees and Manufacturers of Capco Enamelled Wire cleaning machines.*

Illustration shows latest Model of the Quartz Cutting Machine developed and designed in collaboration with engineers of the Radio Branch of the Post Office.

Similar machines have been supplied to the Post Office and to the leading Telephone and Radio Manufacturers.

Standard and heavy duty cutting machines with high rates of cutting to accuracies of .001 in.

Fixtures to hold any shape of crystal can be supplied.

Heavy Duty Machine can now be supplied with nine rates automatic feed through specially designed gear box, sensitive instantaneous stop through specially designed clutch.

Acknowledged to be the finest machines of their kind for this class of work.

*Manufacturers :*

**CAPLIN**  
**ENGINEERING CO. LTD.**

Precision Engineers

**BEACONSFIELD RD., WILLESDEN**  
**LONDON, N.W.10**

Telephone :  
WILlesden 0692.

Cables :  
Caplinko, London.

ESTABLISHED 1918

---



---

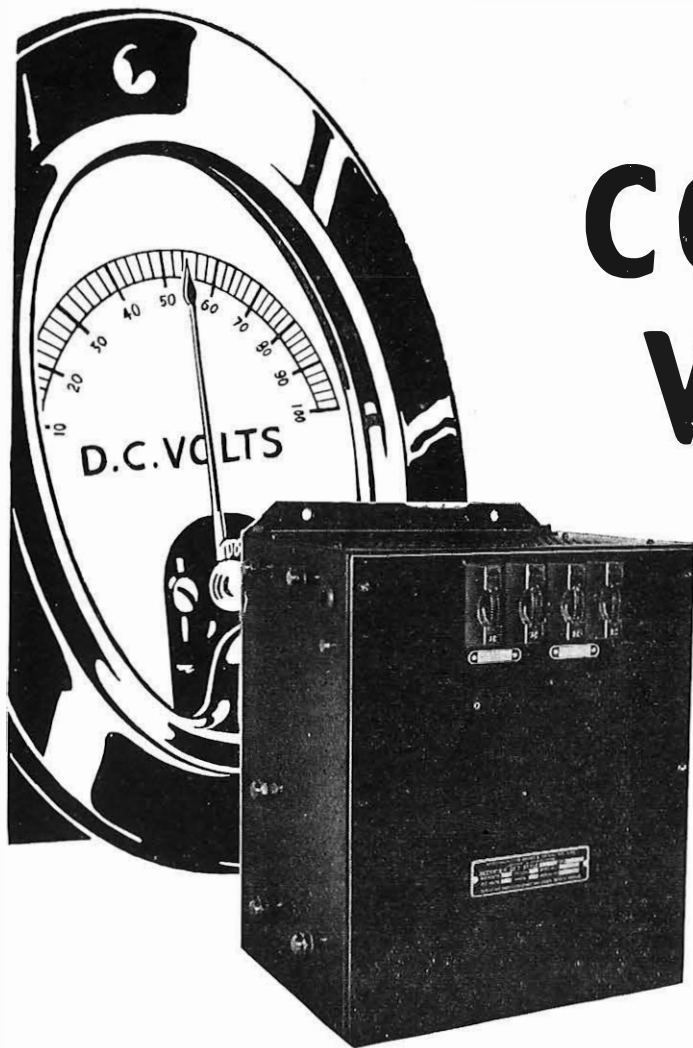

# CONSTANT VOLTAGE

irrespective of load  
current variations  
or mains fluctuations

A completely new system, comprising  
rectifier, two transformers, condenser  
and choke, for floating and recharging  
a battery.

The "Westat" constant voltage rectifier for use with batteries combines all the inherent advantages of the Westinghouse Metal Rectifier with ability to meet all the requirements of floating battery work. It's reliable, efficient and cheap; and it maintains the voltage constant irrespective of load current variations or mains fluctuations.

The feature of this development is that two transformers are energised by a current displaced by about 90°, and are connected to form a Scott group, the secondaries being associated with a three-phase bridge rectifier. Constant D.C. voltage with variations in load is obtained by the injection of the third-phase voltage, while the design of the transformers compensates for variations in mains pressure.

## Westinghouse

### "WESTAT" CONSTANT VOLTAGE RECTIFIER FOR USE WITH BATTERIES

Write for descriptive pamphlet No. 11 (Suppt. F.) to Dept. P.O.E.J.

WESTINGHOUSE BRAKE & SIGNAL CO., LTD., PEW HILL HOUSE, CHIPPENHAM, WILTS

# SIEMENS

CONTRACTORS FOR THE  
MANUFACTURE AND LAYING OF  
**TELEPHONE CABLES**

AERIAL • UNDERGROUND • SUBMARINE WITH CONTINUOUS  
OR COIL LOADING

## LOADING COILS



LAYING SUBMARINE TELEPHONE CABLES

### SIEMENS BROTHERS

WOOLWICH, LONDON

Telephone : WOLWICH

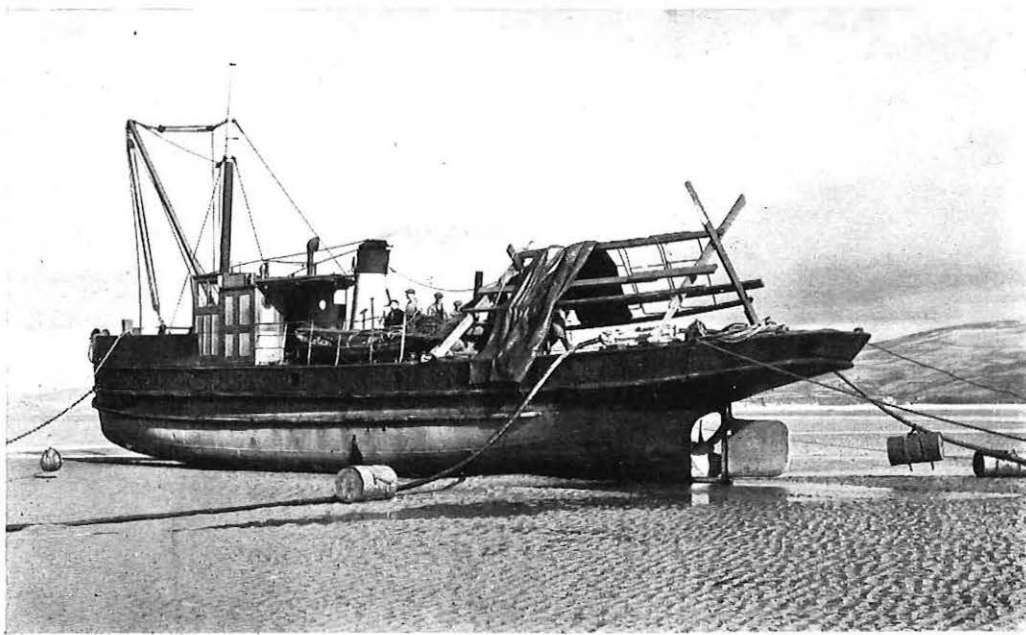

CABLE ACROSS AN ESTUARY

**RS & CO. LIMITED**

LONDON, S.E.18

OLWICH 2020

Completely Self-Contained

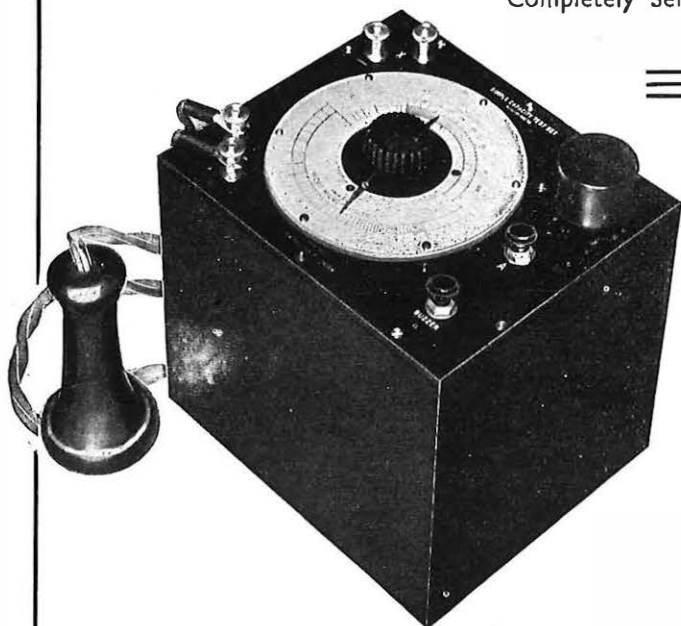

# ≡ CAPACITESTER ≡

FOR PRODUCTION OR FAULT LOCALISING

This tester gives a direct reading on a single dial of any capacitance between  $50 \mu\mu\text{F}$  and  $5 \mu\text{F}$  with an accuracy 1 to 2 per cent.

Its extreme portability renders it most useful for testing components assembled inside large equipment, while a special feature of design minimises the necessity of having to disconnect the condenser under test from its circuit.

The price of this tester is £6 . 10 . 0 + 5% + 5%.

Two other models are available :—  
One having a slightly better accuracy with a range from 0 to  $8000 \mu\mu\text{F}$  and another specially suitable for cable fault localising.

Refer to our Catalogue No. A.C.820 (page 120).

## H. W. SULLIVAN LIMITED

LONDON, S.E.15

Telephones  
NEW CROSS 3225 (P.B.X.)

Telegrams :  
STANDELECT, PECK, LONDON

*"Sullivan" guarantees accuracy*

# EDISWAN

## TELEPHONE LINE PROTECTOR PANELS

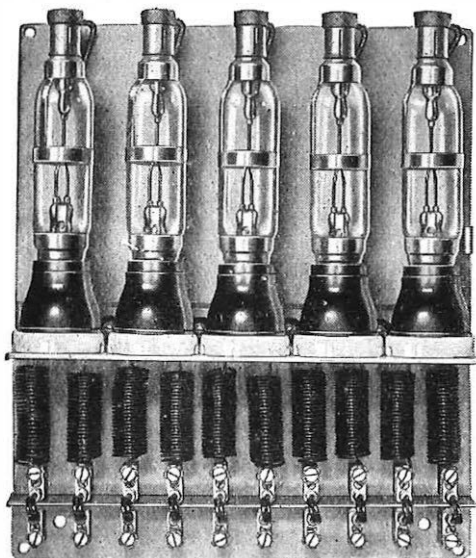

5-circuit panel for overhead lines incorporating choke coils, spark gaps, etc.

EDISWAN-SHOTTER-GREETHAM PATENT

(British Patent No. 353924)

for the protection of telephone systems against surges induced by faults on neighbouring power lines

Of the difficulties attendant upon the employment of overhead systems one of the most serious is to ensure uninterrupted working of the telephone system, by providing adequate protection against induced surges caused by switching or line faults in adjacent power lines or by lightning.

The Ediswan Patent Protectors provide the solution. They are inert at the normal working pressure of the telephone line, they keep the voltage on the line down to a pre-determined figure by providing a path of low resistance to earth whereby the surge is cleared and they again become inert immediately the surge is cleared.

They ensure simultaneous discharge of both lines and are capable of clearing heavy discharges without detriment to the system or the protector.

**Ediswan Telephone Line Protectors have now been in use by Supply Companies for many years.**

THE EDISON SWAN ELECTRIC CO. LTD.,  155 CHARING CROSS ROAD, LONDON, W.C.2



# RAWLPLUG TOOLS & DRILLS



IN addition to being the manufacturers of Rawlplugs and other well known fixing devices, the Rawlplug Co., Ltd., have for many years made a wide range of boring tools. Introduced originally to make the holes to accommodate Rawlplug Fixing devices, the range of tools has been extended year by year until today there is a Rawlplug boring tool suitable for boring holes of all sizes in all materials.

In order to bring Rawlplug Tools to their high standard of efficiency, thousands of pounds have been spent in research, with the result that the tools are manufactured from a special steel, produced to our own secret formula. This special steel ensures both efficiency and long life. *Please write today for fully illustrated literature of complete range.*

THE RAWLPLUG CO. LTD., CROMWELL ROAD, LONDON, S.W.7

**RAWLDRILLS  
TILE DRILLS  
TUBULAR DRILLS  
STAR DRILLS**

B 231



MODEL NO 3A TAPE TELEPRINTER



MODEL NO 5 PM.  
MURRAY KEYBOARD PERFORATOR

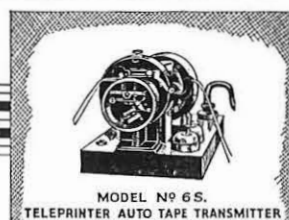

MODEL NO 6 S.  
TELEPRINTER AUTO TAPE TRANSMITTER

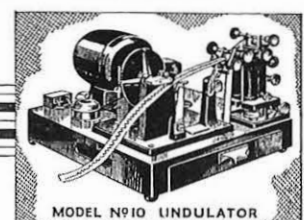

MODEL NO 10 INDULATOR

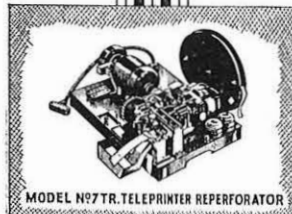

MODEL NO 7 TR. TELEPRINTER REPERFORATOR

ILLUSTRATED are some of the instruments manufactured to provide printing telegraph machines to meet all modern communication requirements.

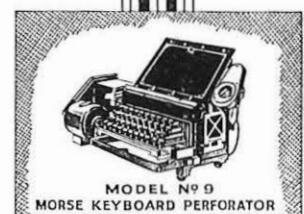

MODEL NO 9  
MORSE KEYBOARD PERFORATOR



MODEL NO 11  
MORSE AUTOMATIC TAPE TRANSMITTER



MODEL NO 7  
PAGE TELEPRINTER  
WITH COMMERCIAL TYPEWRITER KEYBOARD

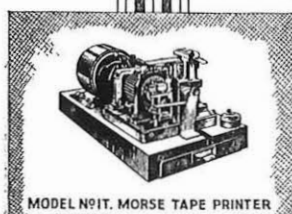

MODEL NO 1 T. MORSE TAPE PRINTER

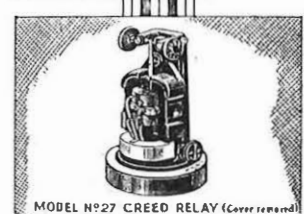

MODEL NO 27 CREED RELAY (Cover removed)

## CREED & CO. L<sup>TD.</sup>

Telephone:—  
Croydon 2121

Telegraph House  
CROYDON

Telex:—  
Croydon Telex 1082



# SELENIUM RECTIFIERS IN SERVICE

No. 2.

## STARTING OF INTERNAL COMBUSTION ENGINES



OWING to its good regulation and relatively small size and weight, the **Standard** Selenium Rectifier is particularly suitable for replacing a battery when heavy currents are required for short periods. The illustration shows one of a group of portable units employing Selenium Rectifiers for starting aeroplane engines in the field, and marketed by Messrs. Rotax Ltd. This unit has a normal output of 300 amperes at 12 volts or 150 amperes at 24 volts, and much heavier currents can be drawn momentarily. Similar units of non-portable type are in service for starting engines on the test bench. *Full particulars of these starters will be supplied on application.*

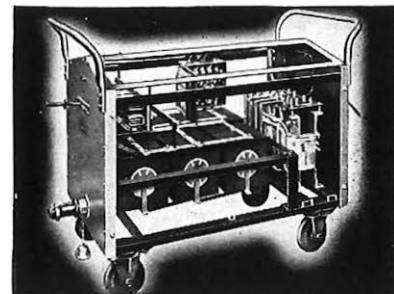

A Portable Unit employing Selenium Rectifiers  
(Cover removed)

## *Standard Telephones and Cables Limited*

OAKLEIGH ROAD, NEW SOUTHGATE, LONDON, N.11

TELEPHONE: ENTERPRISE 1234

# THE POST OFFICE ELECTRICAL ENGINEERS' JOURNAL

Vol. XXXII

January, 1940

Part 4

## New Developments in Power Circuit Guarding R. E. RIMES, B.Sc.

U.D.C. 621.315.1 : 621.316.963

New joint high and low voltage overhead power distribution systems have necessitated a review of Post Office regulations regarding separating distances and guarding. Details of tests made and of the new regulations are given.

### Introduction

**D**URING the last few years there has been considerable growth in the number of overhead power lines erected in rural areas, and development continues. The supply of electricity to outlying villages and small hamlets, mainly for domestic purposes, has greatly increased the difficulty of maintaining the voltage drop within the statutory limit of  $\pm 6$  per cent. of the declared voltage. The power undertaker has at his disposal several ways of meeting this difficulty, but much depends upon the character of the area to be served. In compact villages the high voltage supply can be brought to the outskirts of the village and low voltage distribution conveniently extended with little or no difficulty as regards voltage drop. Other areas to be served may consist of scattered houses and farmsteads, making it necessary to bring into use heavier conductors for distribution purposes than would otherwise be needed. Alternatively existing single phase distribution lines can be converted to 3-phase working with balanced loads, or a high voltage feed to the area can be extended to additional step-down transformers situated near the load centres. In all cases the revenue to be obtained from these new areas of supply will obviously be small, and consequently permissible expenditure is small.

The system of distribution which has recently been developed by several large power undertakers is similar to that which is in extensive use in America, and has been made possible in this country by some relaxation of the Electricity Commissioners' regulations governing high voltage lines. To encourage the development of the new schemes, the Electricity Commissioners have given their special consent to the erection of smaller line conductors than had hitherto been permissible, thus making it possible in certain circumstances to run high voltage feeders on existing poles carrying low voltage distributors. It was soon realised, however, that in many situations in which P.O. plant was involved, little use could be made of the Electricity Commissioners' relaxed regulations, unless the P.O. rules regarding separating distances and guarding could also be somewhat relaxed. Accordingly, the arbitrary P.O. rules were very carefully reviewed to see how they could be re-framed to suit the new conditions without sacrificing safety.

### Joint H.V. and L.V. Distribution.

The new system of distribution provides for the extension of an existing high voltage feed via conductors erected wherever possible on the same poles as the low voltage distributors, the voltage being stepped-down by pole-mounted transformers at, or near, the load centres as desired. The high voltage extension feeders operate at voltages not exceeding 6.6 kV to earth. To meet the requirements of sparsely populated areas single phase feeders are provided, and the system is worked with one conductor earthed. The earthed line is run vertically below the live conductor, and consequently acts as a guard wire, an essential safeguard for the public where the lines run along the highway. A typical example of a single phase 6.6 kV single phase line showing this type of construction is seen in Fig. 1.

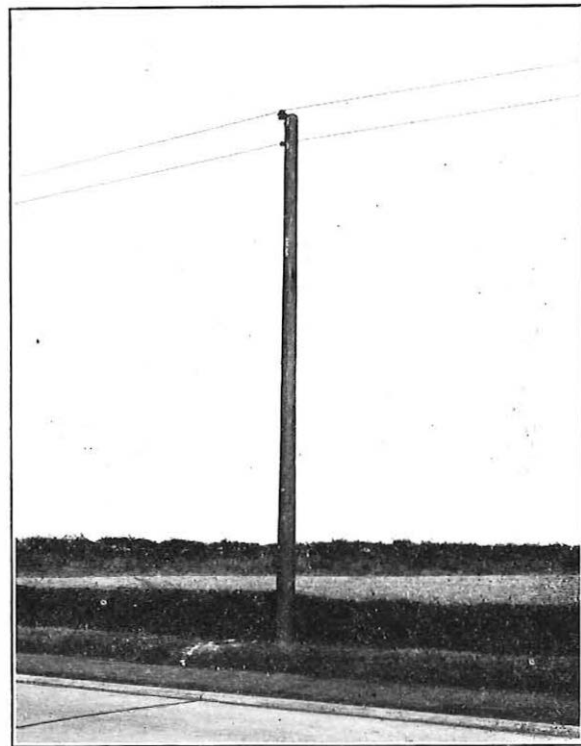

FIG. 1.—TYPICAL 6.6 kV SINGLE PHASE LINE.

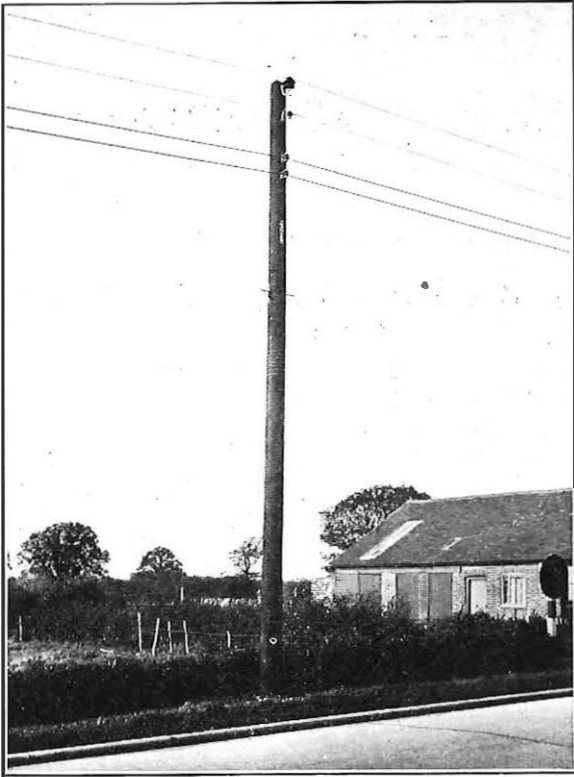

FIG. 2.—6.6 kV SINGLE PHASE FEEDER WITH LOW VOLTAGE DISTRIBUTION ON SAME POLE.

Fig. 2 shows a 6.6 kV single phase feeder with single phase low voltage distribution on the same pole.

The application of the existing Post Office regulations as regards physical clearance would have the effect of prohibiting the erection of these light rural high voltage lines on many relatively narrow country roads already occupied by Post Office overhead routes. Moreover, the provision of elaborate cradle guards at crossings or the underground cabling of the Post Office wires to meet the Department's requirements would probably defeat the power undertakers' purpose of cheapening erection costs.

The Department's contribution to the arrangement was a relaxation of the existing Post Office regulations as regards permissible separating distance and protective measures to be applied at crossings.

#### Distance between Power and P.O. Lines.

So far as separating distance is concerned there has been no departure from the basic principles which have been followed for more than 30 years, namely, that high voltage power lines and telegraph and telephone lines should be so placed that neither line shall foul the other in the event of one of them overturning. Where, however, it had previously been considered necessary

to make an allowance for the possibility of comparatively light telephone wires being blown on to the power lines in a high wind by calling for a minimum separation equal to one and a half times the height of the telephone line, provided that this clearance was greater than the height of the power line, the new special P.O. requirements provide that the separation shall be such that "if the power line overturns in the direction of the Post Office line, no part of any non-earthed conductor of the high voltage system shall pass within 6 ft. of any Post Office wire, and conversely if the Post Office line should overturn in the direction of the power line no part of any Post Office wire shall pass within 12 ft. of any non-carthed power conductor."

In formulating this new rule an effort has been made to take into consideration the actual travel of an overturning route, and to make sufficient allowance for the flying-out of broken wires on either route under gale conditions.

Tables have been prepared which give the required separation with given pole heights to conform with the new clearance rules, although the same object can be achieved by a nomogram or specially constructed slide rule. The latter method has been adopted by several power undertakers, but the process involves the evaluation of the expression:—

$$c = \sqrt{d^2 + b^2} - a$$

where three of the terms are known (see Fig. 3). It will be seen that the value of "a" will be 6 or 12 according to which pole is assumed to overturn.

Where an existing low voltage power line is to be modified to carry high voltage conductors in addition, the factor "a" needs to be determined from known values of "a," "b" and "c."

Where both lines must occupy opposite sides of a public road other considerations, however, arise. It is an established principle that telephone or telegraph wires must always cross below high voltage power conductors, and consequently the power poles must be of such a height that when they carry a full complement of wires including low voltage distri-

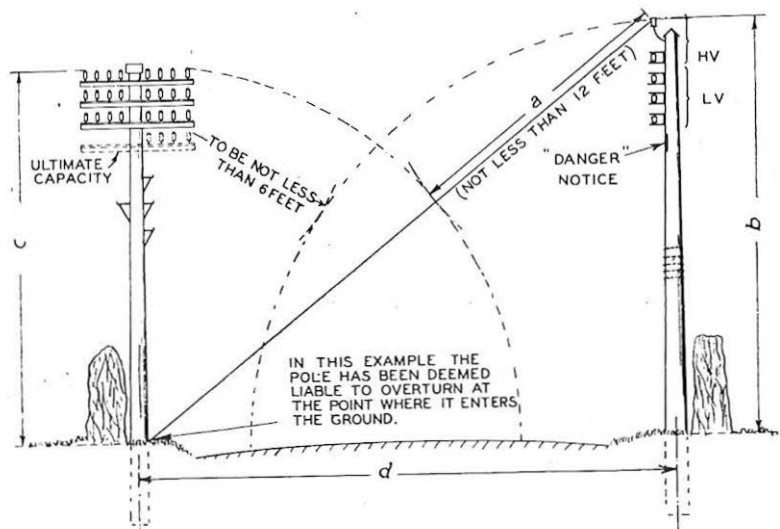

FIG. 3.—DISTANCE BETWEEN POWER AND P.O. LINES.

butors, it will still be possible for the Post Office to run subscribers' services across the road and thence under the power wires with adequate clearance, above the road and below the power conductors. This double requirement sometimes necessitates a higher power pole which, however, itself leads to the need for greater separation than the limits of the public road permit. Where no solution of this difficulty can be found by setting back a few P.O. poles, alternative routing of the high voltage line may become unavoidable.

To reduce the clearance without increasing the risk of contact, attachment of P.O. subscribers' wires to the power poles at crossings is regarded as the best solution. Consequently, the new P.O. requirements are that it shall be possible to attach subscribers' drops to power poles up to a maximum of four single P.B.J. covered wires or four twin P.B.J. covered wires, with certain safeguards.

#### *Protection Against Leakage.*

In the event of leakage over the insulators supporting the high voltage conductors, an appreciable voltage drop may appear on the pole itself; but to guard against this condition it is a requirement that the metal work supporting the insulators to which the earthed high voltage conductor is attached shall be electrically connected to the earthed high voltage conductor. Furthermore, the power undertaker must ensure that under normal conditions the earthed phase of the high voltage system shall not at any point attain a voltage to earth exceeding 60 V.

The earthed conductor is accepted as a guard wire provided it is in the same vertical plane and immediately below the live conductors. If any other formation is adopted which may render the guard wire ineffective, a conductor-catching device electrically connected to the earthed conductor must be fitted under each live line at each end of the span on either side of the attachment pole. The device normally consists of a series of vertical galvanised iron spikes welded to a horizontal arm and bracket for attachment to the pole. The bracket projects about 2 ft. out from the pole, in such a position that the spikes are approximately 6 in. below the live H.V. conductors. Where low voltage distributors or consumers' service wires are also attached to the pole, the neutral or earthed conductor must occupy the lowermost position; and provided that all the conductors are in vertical formation the neutral or earthed conductor may be regarded as a guard wire for the prevention of direct contact between a falling live low voltage conductor and the telephone wires below. If any other arrangement is used the live low voltage conductors must be insulated.

To reduce further the risk of leakage to the pole from faulty insulators, the end of the binding wire on the bare neutral low voltage conductor is taken under the nut at the bottom of the pin supporting the insulator to bond the metalwork to the low voltage earthed wire. If there are no low voltage conductors to be provided on the pole the metal brackets for supporting the P.O. insulators must be separately earthed at the base of the pole, and

some form of barrier such as an earthed guard wire fitted immediately above the telephone wires to prevent the Department's linemen touching any power wires above the telephone wires.

It is a rigid requirement that the telephone wires where they are attached to the power undertaker's pole shall be insulated with a covering of P.B.J., because a light bare telephone wire is liable to be blown about by high winds into dangerous proximity to the power wires. The P.B.J. covered telephone wires should be attached to the pole not less than 1 ft. 9 in. below the neutral or earthed low voltage conductor, and not less than 3 ft. below the earthed high voltage conductor.

There must always be a "DANGER" notice between the telephone wires and the lowest power conductor. A typical example of attachment of telephone wires to a pole carrying a single phase 6.6 kV and single phase low voltage line is shown in Fig. 4.

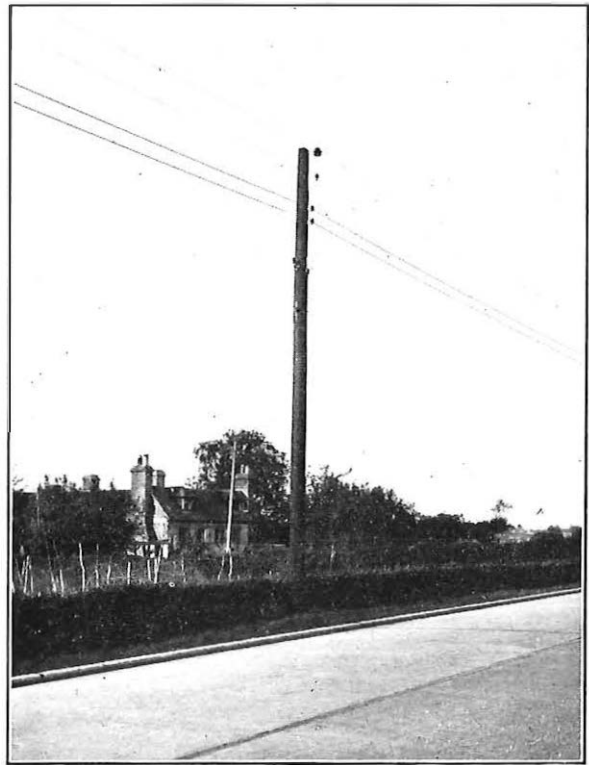

FIG. 4.—ATTACHMENT OF TELEPHONE WIRES TO POLE CARRYING 6.6 kV AND LOW VOLTAGE LINES.

#### *Tests with Falling Conductors.*

Since the P.B.J. insulation on the telephone wires can afford no protection against high voltage the possibility of contact between a high voltage conductor and the telephone wires calls for careful consideration. Tests on a representative type of power line construction have been made to determine as far as possible the travel of a falling high voltage conductor. As a first consideration it may reasonably be assumed that breakage of the conductor will generally occur at or near the binding to its supporting insulator. For the tests, therefore, it was

arranged to cut the conductor near the insulator and to record by a relay set giving visual indication the number and order of any contacts, and to obtain contact times from an oscillographic record. A schematic arrangement for the test is shown in Fig. 5.

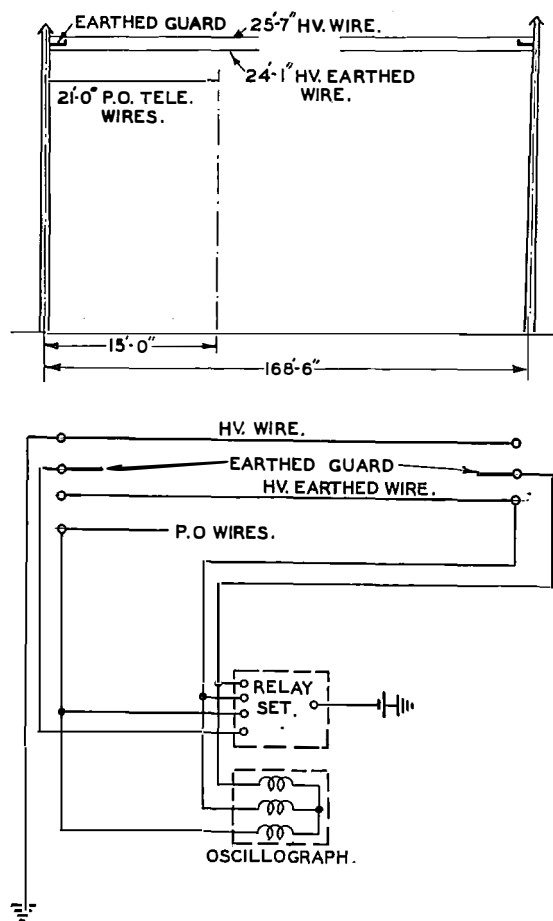

FIG. 5.—TEST CIRCUIT.

The relay set recorded on a series of coloured lamps the sequence in which contacts occurred. Seven successive breaks were made, the conductor being re-erected to normal sag after each test. Alternative forms of earth bar were tried, and the last two tests were made after the conductor had been strained. The telephone wires consisted of a pair of 40 lb. cadmium copper wire run out for a distance of 15 ft. under the high voltage conductors, and cross-laced at intervals of 1 ft. to ensure that a contact would be recorded even though the falling conductor would, under the conditions of test and in the absence of the cross-lacing, have fallen between the wires. The most significant result of the tests was the consistent recording of contact between the falling H.V. conductor and the earthed conductor before contact was made with the earthed bar at the end of the span remote from the break. With the earthed conductor in position no contacts with the telephone wires were recorded, irrespective of whether the conductor under test had been previously strained or not. One contact with the telephone wires was,

however, registered after the earth conductor had been removed and the high voltage conductor under test had been previously overstressed. An average time interval of 240 milliseecs or approximately  $\frac{1}{4}$  sec. elapsed between the cutting of the conductor and contact with the earthed wire, and a further average time interval of 200 milliseecs until the first fleeting contact with the distant earth bar was recorded.

For several of the tests continuous contact with the earthed wire was registered simultaneously with a series of fleeting contacts with the distant earthed bar. The average time interval before permanent contact with the earthed bar was recorded was 1.7 secs., and therefore the conductor may be regarded as continuously earthed throughout the period  $\frac{1}{4}$  sec. after the break. The effect of omitting the spikes on the earthed bar is to delay the first fleeting contact, but to shorten the period before permanent contact is secured.

The tests demonstrated that the earthed conductor forms an efficient guard wire, but the earthed bars also proved to be useful additional safeguards. In the normal attachment the angle between the power lines and the telephone wires when viewed in plan will not be less than 30 deg. so that there should be a large margin of safety from the point of view of possible contact due to breakage of a high voltage conductor at or near the attachment pole.

#### Additional Safeguards.

Where the number of wires on the Post Office route makes it undesirable to negotiate a crossing by attachment, arrangements must be made to catch a falling high voltage conductor, and thus to prevent contact with the telephone wires crossing below. To achieve this a cradle guard of lighter construction than normally employed on heavier lines is used consisting mainly of a duplicate earthed high voltage wire cross-laced in the neighbourhood of the crossing. A typical example of such a guard is shown in Fig. 6. If the power line carries also low voltage conductors in the crossing span the normal requirements for low voltage guarding must be applied additionally.

Mention should be made of the earthing and circuit control on the power system. The earthed high voltage conductor is earthed at one point only, namely, at the main step-down transformer, and a fuse is provided in each live phase. The low voltage conductors are fused on the L.V. side of the 6.6 kV/L.V. pole-mounted transformer at which point it has been the common practice to earth the neutral of the L.V. system. As it is necessary to earth the transformer tank at the pole there would be a risk that the potential of the low voltage system with respect to earth may rise considerably on the occurrence of a high voltage fault to the earthed tank. This risk is obviated by connecting the low voltage neutral to earth at a point at least one span away from the transformer pole.

The provision of self-reclosing circuit breakers avoids transitory interruptions in the supply due to such line trouble as may be caused by birds or accumulation of wet straws or hay blown by the wind on to the line wire near the insulators and metal-

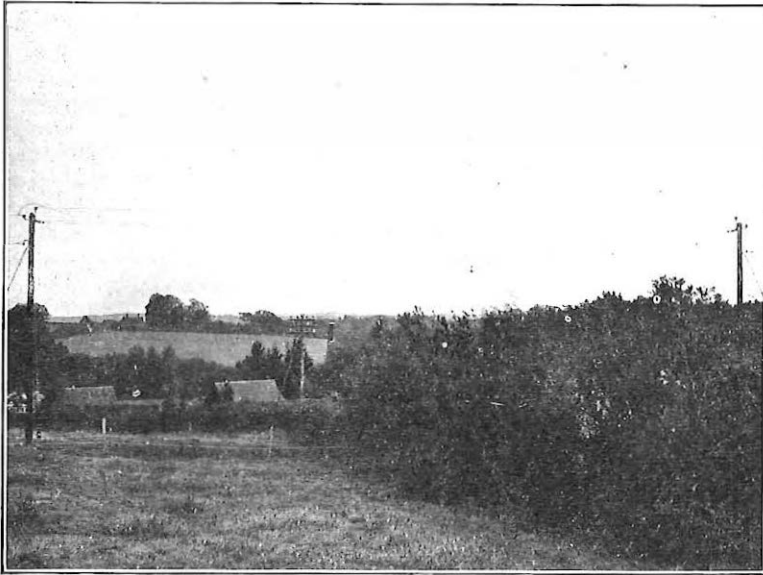

FIG. 6.—CRADLE GUARD FOR HIGH VOLTAGE CONDUCTOR CROSSING P.O. WIRES.

work ; but in the event of breakage of a live high voltage conductor it is reasonably assured that contact will first be made with the earthed conductor and continuous contact later with the earthed bar, thus tripping the circuit breaker permanently or blowing a fuse that was not blown by a fleeting contact.

The short-circuit current on these light rural lines is relatively small, and consequently serious longitudinal voltages will not be induced in telephone circuits paralleling the power lines.

## Carrier Frequency Synchronisation

The introduction of 2 V.F. signalling on trunk routes will make it necessary to provide synchronisation of carrier frequencies on all carrier systems over which the new signalling scheme will operate. Efforts have already been made to maintain the carrier frequency errors as small as possible on all systems because of their effect on speech transmission, and more particularly on V.F. telegraphs. The requirements of the 2 V.F. signalling system are, however, such that in order to ensure satisfactory working at all times a programme of complete carrier synchronisation was decided upon.

The first installation of the signalling equipment was put in service on the London-Bristol-Plymouth route in July, 1939, and, consequently, carrier synchronisation has been provided on the 12-channel carrier systems on this route in advance of a decision as to the most suitable method of synchronisation for standardisation. The method adopted in this case is, briefly, as follows :—

Noise interference by electro-magnetic induction into the untransposed loop of neighbouring telephone circuits is similarly unlikely to arise. So far no case of noise interference with the telephone system has arisen, and calculation shows that the voltages induced electro-magnetically are not likely to produce any trouble. However, it would appear that the voltages on the telephone wires arising from electric induction may approach the limits of safety for P.O. personnel if the parallel is as long as two miles at normal roadway separation. Such extensive parallels have not been encountered, but experiments are in hand to verify these calculations and to determine the limit of power system voltage and length of parallel which can be permitted.

### Conclusions.

The erection of high voltage power lines along the side of public roads in close proximity to telephone and telegraph poles and wires calls for a high standard of maintenance to ensure that the required factors of safety are maintained. Furthermore, close co-operation between the power undertaker and the Post Office is essential at the planning stage if both services are to be developed as economically as possible.

Thanks are due to the Central Sussex Electricity Co. for their co-operation in the tests on falling conductors.

A pilot signal of 9 and 10 kc/s tones derived from a standard 1 kc/s supply is transmitted from London over a London-Bristol system. A pilot signal of this nature can evidently be used on a working system without interference with the traffic channels. At Bristol this signal is demodulated, producing a 1 kc/s tone; this is then converted to 4 kc/s and used to lock the master 4 kc/s oscillator. From the output of this oscillator, a 4 kc/s pilot signal is sent over a working system to Plymouth, where it is used to lock the master oscillator there. The whole system is in this way locked to a standard 1 kc/s tone at London. The above scheme has been set up without difficulty and is now working satisfactorily in service. No spare equipment is yet provided, however; ultimately, automatic change-over facilities will be provided. Also, the system will be extended to Birmingham.

It is hoped to publish an article giving details of this scheme at an early date.

# The Essential Characteristics of Television Circuits

U.D.C. 621.397.2 : 621.397.8

R. F. J. JARVIS, Ph.D., and  
E. C. H. SEAMAN, B.Sc.

A brief summary of the published data regarding the characteristics of various television circuits is given but no tests to determine the deteriorating effect of circuits with various known responses have yet been made. Three methods are suggested, however, whereby this problem can be analysed. The results of tests of the interfering effect of random and single frequency noise are given and values for overall gain stability are suggested. It is suggested that non-linear distortion in circuits not employing frequency translation should be defined by graphical limits to the output versus input voltage characteristic of the circuit.

## Introduction.

WHEN new systems of communication are developed the need soon arises for a knowledge of the limits which must be imposed on the characteristics of the system to achieve the desired results. For television systems it was some time before the need for a proper knowledge of such limits was fully appreciated and before it was even fully realised what a wide frequency band-width was necessary to achieve good definition. No complete scientific study of this problem has yet been published, and it is proposed in this article to indicate several methods by which the permissible limits of attenuation and phase response of a television system might be determined and to give a brief summary of the limits of signal-to-noise ratio found to be necessary experimentally. The article is intended to be only a preliminary examination of the subject and a considerable amount of work remains to be done to carry out all the suggestions outlined for determining the desired limits of attenuation and phase response. The limits which are examined are those which must be applied to the overall circuit from the picture producing source to the received picture. The effects of aperture distortion at the transmitter and receiver are not separately considered as aperture distortion can be regarded as part of the electrical circuit distortion, the effects of aperture distortion being reproducible by electrical circuits and also capable of correction by such circuits. The final division of the overall limits between the various parts of the circuit is not considered, and is, of course, a question which must ultimately be determined largely on economic grounds.

## The Essential Characteristics.

The usually accepted essential characteristics of a television circuit on which limits should be imposed are:—

- (a) The frequency band for which limits of response are to be specified.
- (b) The attenuation-frequency response in this band.
- (c) The phase delay-frequency response over this band.
- (d) The minimum signal-to-noise ratio with various types of noise.
- (e) The overall gain stability.
- (f) Non-linear distortion.

It will be noted that the first three of these characteristics are stated in terms of the steady state frequency response of the circuit. These characteristics

can be replaced by a single characteristic, namely the time response of the circuit to a unit impulse voltage applied in the transmitting branch, and the use of this characteristic as an alternative to (a), (b) and (c) will be considered briefly.

## THE EFFECTIVE FREQUENCY BAND-WIDTH NECESSARY

In order that the average brightness of the picture may be faithfully reproduced it is necessary to transmit all lower frequencies down to and including zero. The lower frequencies can, however, be attenuated and the D.C. or zero frequency component completely removed in one part of the circuit, providing these are reconstituted later by bringing the bottoms of the synchronising pulses, or the black level in the picture signal, to a constant level by a rectifier circuit. If such reconstitution is carried out the allowable loss at low frequencies depends partly on the efficiency of the D.C. restoring circuit and partly on the maximum permissible reduction of brightness across the picture. With the most efficient D.C. restoring circuits the latter is the predominant factor. If the low frequency loss is brought about by a single resistance-capacitance coupled stage of amplification with a loss of 3 db. at 50 c/s, the change of brightness across the picture is approximately 3 per cent. in 405 line pictures with a picture frequency of 25 c/s. This change of 3 per cent. has been regarded in some quarters as the maximum tolerable.

Various methods have been suggested for estimating the maximum frequency which it is desirable to

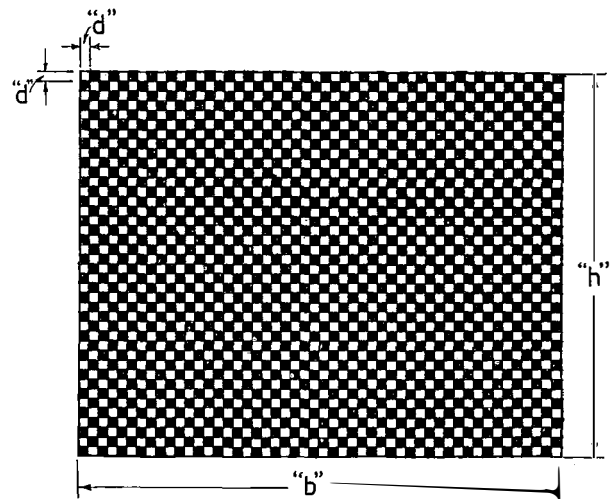

FIG. 1.—DIVISION OF THE PICTURE INTO BLACK AND WHITE SQUARES, WITH SIDES EQUAL TO THE LINE THICKNESS.



transmit. The usual method is to consider a picture consisting of alternate black and white squares, the side of each square being equal to the thickness of a line, as shown in Fig. 1. Such a picture has equal fineness of detail in the vertical and horizontal directions, and the detail in the vertical direction is the finest possible with the line structure employed in scanning.

- Let  $b$  = width of visible picture.  
 $h$  = height of visible picture.  
 $r$  = aspect ratio =  $b/h$ .  
 $n$  = total number of lines.  
 $n_p$  = number of lines in the visible picture.  
 $d$  = thickness of a line =  $h/n_p$ .  
 $\alpha$  =  $\frac{\text{time taken to scan visible part of line.}}{\text{total periodic time of each line.}}$   
 $\beta$  =  $n_p/n$ .  
 $f_p$  = number of pictures per second.

Then the total number of squares having sides equal to the thickness of a line, in the visible part of a line

$$= \frac{bn_p}{h}$$

The time taken to scan the visible part of the line

$$= \frac{\alpha}{f_p n} \text{ seconds}$$

and the time taken to scan two elementary squares is

$$\frac{\alpha}{f_p n} \div \frac{1}{2} \frac{bn_p}{h} = \frac{2h\alpha}{f_p bn_p} \text{ seconds.}$$

Hence the fundamental frequency obtained by scanning the black and white squares is

$$\frac{1}{2} \cdot \frac{\beta}{\alpha} \cdot r f_p n^2 \text{ cycles per second} \dots\dots\dots(1)$$

In the E.M.I. system employed at Alexandra Palace<sup>1</sup>

$$\begin{array}{ll} \alpha = 0.845 & f_p = 25 \\ \beta = 0.951 & n = 405 \\ r = 1.25 & \end{array}$$

and the frequency given by equation (1) is 2.88 Mc/s.

It has been suggested that equation (1) gives the maximum frequency necessary to ensure equal definition in the horizontal and vertical directions, but there is some doubt about this point. For example, if the spot scanning a picture of the form shown in Fig. 1 is moved downwards by the thickness of half a line the signal obtained will be a constant level and the picture at the receiver will consist of a uniform grey surface. On the other hand if all the black squares are arranged in vertical rows, so that the picture consists of alternate black and white vertical bars, the fundamental frequency produced by scanning is given by equation (1) irrespective of any vertical displacement of the scanning spot. If the picture being scanned consists of horizontal black and white bars of thickness equal to the line thickness, the resultant picture at the receiving end may consist of a true replica of the picture being transmitted, or of a uniform grey surface, or of a result between these two extremes, depending on the

vertical position of the scanning spot at the transmitter relative to the horizontal lines being scanned. This suggests that, from the point of view of resolution of detail, a system having a maximum effective frequency of transmission given by equation (1) will give, on the average, a better definition in the horizontal direction than in the vertical. From the point of view of minimum transition distance on the picture from full black to full white, or vice-versa, it will be shown later that, for the maximum frequency given by equation (1), this distance is equal to the thickness of a line in the horizontal direction, while it is clear that in the vertical direction it may lie anywhere between zero and the thickness of a line, depending on the position of the scanning spot relative to the horizontal black and white edge being scanned. Thus from this point of view the definition in the vertical direction is, on the average, better than that in the horizontal direction in a system having a maximum frequency given by equation (1). It would appear that, on the whole, this frequency is a good compromise to the value required to obtain approximately equal resolution of detail and sharpness of black and white edges in the vertical and horizontal directions. It has been suggested that it may not be desirable to aim at equal definition in the two directions, but it is not proposed to discuss this in the present article.

#### *Limits Attained in Various Practical Television Circuits.*

Before considering the limits of attenuation and phase delay which are desirable, it is proposed to give a brief summary of the limits which have been attained in various television circuits, according to published data.

According to data regarding the modulation amplifiers in the Marconi-E.M.I. 405 line transmitter at Alexandra Palace,<sup>2</sup> the overall attenuation response of these amplifiers was flat to within  $\pm 0.05$  db. at frequencies up to 1 Mc/s, and to within  $\pm 0.1$  db. at frequencies up to 2.5 Mc/s. Data regarding the output stage and aerial system of this transmitter<sup>3</sup> show that the input impedance at the transmitter end of the aerial transmission line with the aerial connected varied between 73 and 83 $\Omega$  over the frequency range from 43 to 47 Mc/s (i.e.,  $45 \pm 2$  Mc/s). The output impedance of the output stage of the transmitter feeding this line is fairly high compared with 78 $\Omega$  and the loss on the transmission line is only about 0.2 db. It therefore follows that the overall fidelity of the Alexandra Palace transmitter from the output of the modulator to the modulated aerial current must have been flat to within  $\pm 0.5$  db. over the modulation frequency range 0–2 Mc/s. Thus allowing for the  $\pm 0.1$  db. in the modulator the overall fidelity of the transmitter must have been flat to within  $\pm 0.6$  db. from 0 to 2 Mc/s.

The results obtained on the Marconi-E.M.I. balanced cable television system in London are also of interest in this connection. This network

<sup>1</sup> *I.E.E.J.*, Vol. 83, pp. 758, 801.

<sup>2</sup> *Loc. cit.*

<sup>3</sup> *I.E.E.J.*, Vol. 84, pp. 448, 467.

consists of one repeater section  $7\frac{1}{4}$  miles in length, and another repeater section of variable length up to a maximum of 8 miles. When first set up with a length of 4.3 miles in the variable section, the overall attenuation of the system was constant to within  $\pm 0.5$  db. from 50 c/s to 2.0 Mc/s. The overall phase characteristic of the system was not measured but the designers stated that a phase shift linear to within  $\pm 3^\circ$  had been aimed at to as high a frequency as practicable, although this was probably not obtained up to 2 Mc/s. When this network was properly adjusted it was very difficult to detect any difference between the transmitted and received picture.

Some details of the early German experiments on the transmission of 180 line pictures by cable were given by A. Agricola.<sup>4</sup> The vision frequency band width was only 500 kc/s, the television signal being transmitted on the cable as a single sideband modulation for a 800 kc/s carrier frequency. The measured precision of correction of attenuation distortion over two repeater sections, each of about 22 miles in length, was  $\pm 1.2$  db. within the frequency range 800-1,300 kc/s, and it was stated that the quality of the transmitted and received pictures was indistinguishable. The differential delay was corrected to within  $\pm 0.05 \mu\text{S}$ , which was considerably better than was really essential for the definition employed.

In 1937 the Bell Telephone Laboratories made experiments on the transmission of 240 line television signals on a coaxial cable circuit between New York and Philadelphia.<sup>5</sup> In these experiments single sideband transmission was employed with a carrier frequency of 144 kc/s and a vision frequency band of 800 kc/s. The overall attenuation on the line was equalised to within  $\pm 1.2$  db. in the transmitted frequency range. The overall phase delay characteristic over the same range was equalised to within  $\pm 0.3 \mu\text{S}$ , which corresponded to the time taken to scan half the width of a picture element. It was claimed that the quality of the received picture was as good as that of the transmitted picture.

It will be seen later that it is probably undesirable to endeavour to define the limits of attenuation and phase delay in terms of single figures applicable over the whole frequency range, as in the examples quoted above. Experiments carried out by the Post Office on transmission of television signals on coaxial cables have shown that a given departure from flatness of frequency response has a much more marked effect on the picture if it occurs in the region of 10-500 kc/s than it does at the top end of the vision frequency spectrum, i.e., about 2.5 Mc/s for 405 line pictures.

#### EXPERIMENTAL DETERMINATION OF THE DESIRABLE LIMITS OF ATTENUATION AND PHASE DELAY.

Apart from the general experience obtained with television circuits the allowable limits in the attenuation and phase delay characteristic of a television circuit might be determined experimentally by passing high quality television signals through

various networks by which variations of these characteristics could be produced, and their effect on various types of picture noted. It will be appreciated that a very large number of observations would be required and the quality of the test signal would have to be as high as possible so that the deteriorating effects of the circuit were fully apparent. Although observations of this type will ultimately have to be made it is thought that simpler and more fundamental methods of estimating the permissible limits are desirable initially. In this connection it is advisable to point out here that the attenuation and phase delay characteristics of a physical circuit are not mutually independent, and this must be borne in mind in the analysis of the problem.

A method is suggested in the next section for determining the allowable limits of attenuation and phase distortion by analysing the effects of imperfect transmission at single frequencies. Circuits producing distortion only over a narrow band of frequencies might be usefully employed in a direct experimental determination of the allowable limits of attenuation and phase distortion with different types of picture. It appears desirable that the observers employed in this type of test should be unbiased by any scientific knowledge of the subject so that their view shall represent, as far as possible, that of an average member of the public.

#### *Determination of the Desirable Limits of Attenuation and Phase Delay based on the Analysis of the Circuit Response to Square Waveform Signals.*

A television signal produced by scanning a fixed picture can be analysed by Fourier analysis into single frequency components which are harmonics of the picture frequency. In general, those components which are multiples of the line frequency have the maximum amplitudes, and the amplitudes decrease with increase in frequency. If, however, the picture consists of vertical black and white bars, a large amount of energy may be concentrated at high frequencies, depending on the width of the bars. Such picture signals would, therefore, appear to be very suitable for examining the effect of variations in the high frequency response of the circuit and this method has been applied by F. Ring.<sup>6</sup> Ring assumed the new German standard of 441 lines, 25 pictures per second and  $4 \times 10^6$  picture elements per second. It is interesting to note here that  $4 \times 10^6$  picture elements per second is smaller than the number of black and white squares scanned per second calculated according to Fig. 1. If the picture aspect ratio is to be  $4/3$ , and  $\beta/\alpha$  (see equation 1) is assumed to be unity, the latter number would be  $6.48 \times 10^6$ , and if the definition is to be the same in the horizontal direction as in the vertical direction this number is probably required. If only  $4 \times 10^6$  picture elements per second are considered necessary the maximum frequency that must be transmitted need only be 2 Mc/s, but if  $6.48 \times 10^6$  picture elements per second are necessary the maximum frequency must be 3.24 Mc/s. Ring then assumed that the picture con-

<sup>4</sup> T.F.T., Dec., 1937.

<sup>5</sup> Bell Lab. Record, Vol. 16, pp. 188, 195, and Elec. Eng., June, 1938, p. 249.

<sup>6</sup> Fernsehen und Tonfilm, May, 1938.

sisted of alternate vertical black and white bars, each 9 picture elements in width, the type of picture being illustrated in Fig. 2. When a picture of this

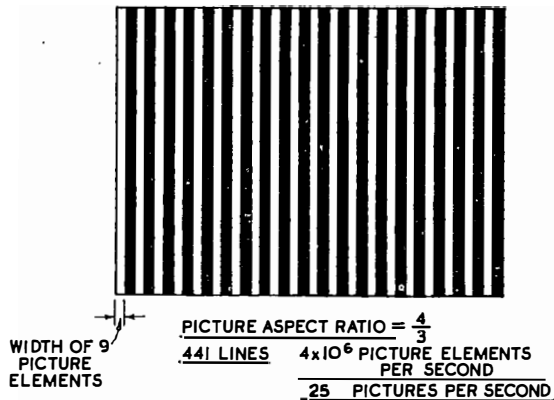

FIG. 2.—PICTURE CONSIDERED BY F. RING.

type is scanned the picture signal resulting has the form of a periodic rectangular wave as shown in Fig. 3. This, of course, illustrates the "picture"

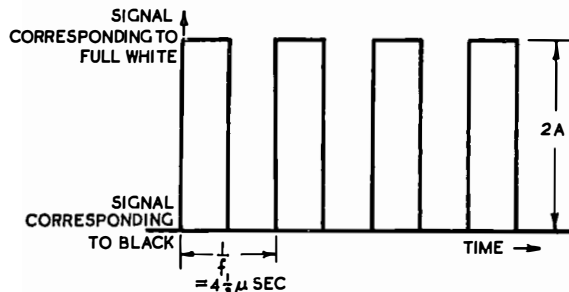

FIG. 3.—SIGNAL PRODUCED BY SCANNING FIG. 2.

signal, the synchronising pulses normally placed below the black level being omitted. This rectangular periodic signal can be expanded by Fourier analysis into the following form:—

$$E = A + \frac{4A}{\pi} \left\{ \sin \omega t + \frac{1}{3} \sin 3\omega t + \frac{1}{5} \sin 5\omega t + \dots \right\} \quad (2)$$

where  $2A$  = overall amplitude between black and full white, generally known as the "double amplitude peak" magnitude of the signal.

and  $\omega = 2\pi \times$  the fundamental frequency.

In the example taken by Ring the fundamental frequency was 222.2 kc/s. He then assumed that all harmonics above the 9th, corresponding to the fundamental picture element frequency of 2 Mc/s ( $4 \text{ by } 10^6 \text{ picture elements per second}$ ) were completely eliminated by the transmission path, and considered the shape of the wave received over transmission paths with various attenuation and phase characteristics in the frequency range 0 to 2 Mc/s.

The waveform of the received wave when all frequencies up to 2 Mc/s are faithfully transmitted is shown in Fig 4. It will be noted from this that the received signal rises nearly to its maximum value in a time equal to the duration of a picture element,

i.e.,  $\frac{1}{4} \mu\text{S}$ . in this case. This time is, of course, half the periodic time of the maximum frequency transmitted (i.e., 2 Mc/s). It will also be noted that the amplitude overshoots its average value (over one complete half-cycle) by 8.7 per cent., and that the amplitude oscillates about this average value with a quasi-period of about  $\frac{1}{2} \mu\text{S}$ , i.e., the periodic time of the maximum frequency transmitted. This oscillation of amplitude may be visible in a receiver with a well focused spot, and the sharp transition from white to black, or vice versa, in the received picture may be followed by a vertical striation of diminishing magnitude. Ring did not discuss this aspect of the result in his article, and the result should be compared with the similar result obtained later in discussing the transient response of a tele-

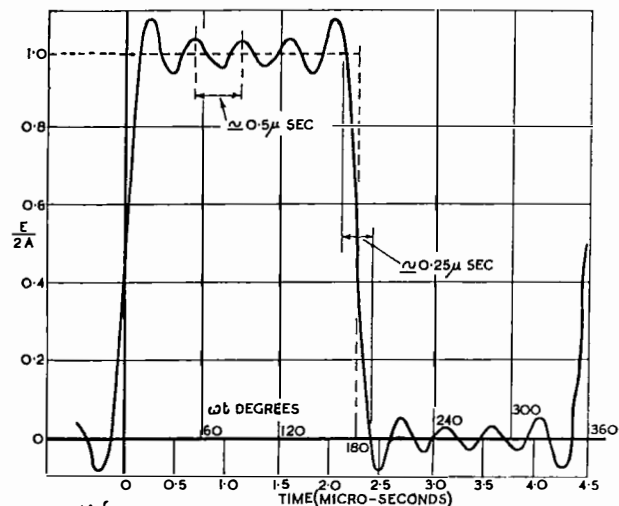

$$E = A + \frac{4A}{\pi} \left\{ \sin \omega t + \frac{1}{3} \sin 3\omega t + \frac{1}{5} \sin 5\omega t + \frac{1}{7} \sin 7\omega t + \frac{1}{9} \sin 9\omega t \right\}$$

FIG. 4.—WAVE FORM OF SIGNAL FORMED BY THE FIRST NINE HARMONICS OF A RECTANGULAR WAVE.

vision circuit. In addition to working out the waveform of the received signal obtained with perfect transmission up to 2 Mc/s, Ring also worked out this waveform for the following transmission characteristics:—

A. With constant phase delay:—

(a) Attenuation rising linearly with frequency by a total amount of 0.9 or 1.4 nepers in the frequency range 0 to 2 Mc/s.

(b) Attenuation falling linearly with frequency by a total amount of 0.4 or 1.0 nepers in this frequency range.

B. With constant attenuation:—

(a) Group transmission time or differential delay ( $d\beta/d\omega$ ) rising linearly with frequency to values of  $\frac{1}{8}$ ,  $\frac{1}{4}$ ,  $\frac{3}{8}$ ,  $\frac{1}{2}$ ,  $\frac{3}{4}$ , 1 and  $1\frac{1}{2} \mu\text{S}$ . at 2 Mc/s.

(b) Differential delay rising quadratically with frequency to values of  $\frac{3}{8}$ ,  $\frac{3}{4}$  and  $\frac{7}{8} \mu\text{S}$ . at 2 Mc/s.

(c) Differential delay rising with the square root of the frequency to values of  $\frac{3}{16}$ ,  $\frac{3}{8}$  and  $\frac{9}{16} \mu\text{S}$ . at 2 Mc/s.

(d) Differential delay a minimum in the middle of the frequency range and rising quadratically to maximum values of  $\frac{3}{16}$ ,  $\frac{3}{8}$  and  $\frac{9}{16} \mu\text{S}$ . at the edges

(e) Group transmission time a minimum at  $\frac{1}{3}$  of the maximum frequency and rising quadratically to a maximum value of  $\frac{1}{2}$ , 1 and  $1\frac{1}{2} \mu\text{S}$ .

Waveform curves for all the above conditions were published, but in this article no definite conclusions were drawn regarding the allowable limits. The attenuation and phase response of a passive network are not mutually independent, a fact which will be apparent later in equations 16, 17, 18 and 19. It is, therefore, doubtful whether the combinations of attenuation and phase response assumed by Ring are physically realisable in practice in linear, passive networks.

It would appear that if conclusions are to be drawn from the waveforms determined in this manner they must be based on the following considerations:—

(a) The minimum perceptible difference in brightness for various average brightness values, if perfect results are desired. Alternatively, the maximum permissible variation in brightness in parts of the picture which should be of even brightness, if the results are to be of an acceptable standard.

(b) The minimum rate of change of brightness permissible at a black and white edge.

According to Fechner's law the minimum perceptible percentage difference of brightness is nearly constant over a wide range of brightness and is equal to about 1-2 per cent. Although no separate tests have been made by the Post Office specially to confirm this, the results of tests indicate that noise is just visible with a ratio of double amplitude peak picture signal to peak noise of about 42 db. at the grid of the cathode ray tube with random noise and about 48 db. with single frequency noise. A ratio of 46 db. would indicate a minimum perceptible percentage difference of brightness of 1 per cent. and 40 db. of 2 per cent. The maximum tolerable difference of brightness in parts of the picture which should be of even brightness is probably of the order of 3 per cent. This figure is suggested by the minimum tolerable signal/noise ratios obtained in the above-mentioned tests.

With regard to the minimum rate of change of brightness at a black and white edge it is obviously desirable that the time taken to change from nearly full white to nearly full black, or vice versa, should not greatly exceed the time required to scan a distance equal to the thickness of the line, if the definition in the horizontal direction is to be as good as that in the vertical. It is interesting to note that this standard would be reached if perfect transmission were obtained up to the frequency given by equation (1).

If limits of this type are to be imposed on the shapes of the received waveforms obtained with rectangular transmitted waveforms then the received waveform must lie within limits such as those suggested in Fig. 5. It is clear that one method whereby the permissible limits of attenuation and phase distortion could be determined would consist of

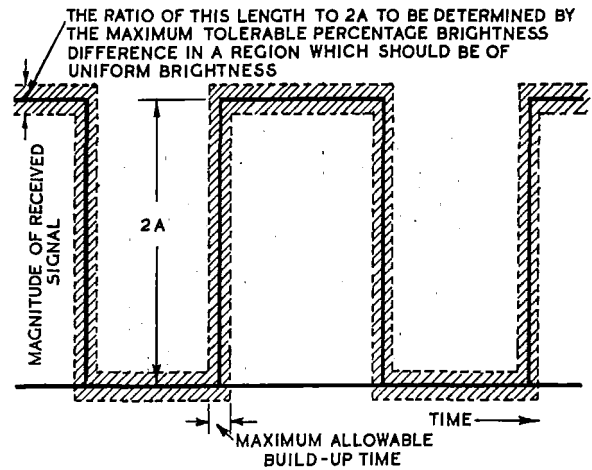

FIG. 5.—LIMITS OF THE RECEIVED WAVEFORM OF A RECTANGULAR TRANSMITTED WAVE.

assuming a range of response waveforms within these limits and analysing these by Fourier analysis. By comparing the magnitudes and phases of the harmonic components of the received wave with those of the rectangular transmitted wave the limits of attenuation and phase distortion at various parts of the frequency spectrum might be determined. The process would be repeated for a range of fundamental transmitted frequencies. It is interesting to note here that this process is essentially the same as that suggested later in dealing with the problem from the point of view of the indicial transfer admittance of the circuit. The latter method is, in effect, a special case of that considered above in which the periodic time of the transmitted rectangular wave is taken as infinite. The limitations pointed out later in this article in connection with the determination of limits of attenuation and phase response from the limits of transient response may also apply here to the square waveform response, and this must be considered in further study of the problem.

*Determination of the Allowable Limit of Attenuation and Phase Delay based on the Interfering Effect of Unwanted Components Introduced by Attenuation and Phase Distortion.*

The method of analysing the response to rectangular transmitted waveforms of various frequencies obviously involves a large amount of labour, and a somewhat simpler method by which the allowable tolerances in the attenuation and phase response might be estimated will now be outlined. The method will be applicable either to the square waveform signals produced by scanning vertical black and white bars or to the signals obtained by scanning any fixed picture.

As previously mentioned, when a fixed picture is scanned the signal produced can be analysed into single frequency components which are harmonics of the picture frequency, and in general those components which are multiples of, or nearly multiples of the line frequency have the maximum amplitudes, and the amplitudes decrease with increase in frequency. In the special case where the picture

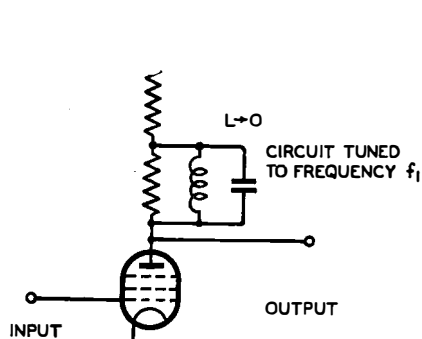
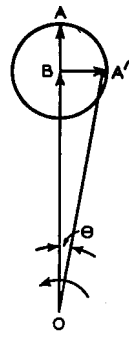

FIG. 6a.—SIMPLE VALVE CIRCUIT WHICH WILL TRANSMIT ALL FREQUENCIES PERFECTLY EXCEPT  $f_1$ .



$\omega_1 (=2\pi f_1)$  RADS. PER SEC.  
FIG. 6b.—EFFECT OF IMPERFECT TRANSMISSION OF ONE COMPONENT FREQUENCY.

consists of  $N$  black and  $N$  white vertical bars the fundamental frequency in the picture signal (omitting synchronising pulses) obtained by scanning is  $Nf_L$  where  $f_L$  is the line frequency ( $=nf_p$ ).

Now suppose that the circuit transmits all frequencies perfectly except that of one of the components. It is theoretically possible for such a circuit to exist, a simple example being indicated in Fig. 6a. Assume that the component frequency  $f_1$  say, which is incorrectly transmitted is represented by the vector  $OA$  in Fig. 6b, but that if it were transmitted perfectly (i.e., with the same attenuation and phase delay as the remaining frequencies) it would be represented by the vector  $OB$ . It is then clear that the television signal received over this circuit will consist of a perfect reproduction of the original signal together with a single frequency component at frequency  $f_1$  represented by the vector  $BA$ . The effect of this component will be the same as if the circuit were perfect but a component of this frequency, magnitude and phase were introduced from an interfering source. Actually the interfering effect of the unwanted component is not likely, in general, to depend much on its phase, and the interfering effect will probably be much the same for any position of the end of the vector  $OA$  on the circle with  $B$  as centre and  $BA$  as radius.

The maximum ratio which can be tolerated between the magnitude of  $BA$  and the double amplitude peak magnitude of the received picture signal can be determined by tests in which a varying proportion of the frequency  $f_1$  is superimposed on the picture signal and the visible effects noted. (This is dealt with again later in considering signal-to-noise ratio.) Fig. 7 shows the results of tests made to determine the maximum visible and the maximum tolerable values of this ratio for various interfering frequencies on the British standard transmissions, and is referred to in detail later.

The maximum ratio which can be tolerated between the magnitude of  $BA$  and the magnitude of  $OB$  will, obviously, also depend on the ratio of the magnitude of  $OB$  to the double amplitude peak magnitude of the received picture signal. This will depend on the nature of the picture and the frequency  $f_1$ . The most difficult type of picture to transmit probably consists

of alternate vertical black and white bars, and the frequency spectrum of the signal produced by scanning this type of picture has already been examined. In this picture the ratio of the magnitude of the fundamental component (neglecting the synchronising pulses) to the double amplitude peak magnitude of the picture signal is  $-3.9$  db. If the fundamental frequency is less than about 500 kc/s it then appears from the results indicated in Fig. 7 that the maximum tolerable ratio of  $BA$  to  $OB$  at this fundamental frequency will be about 0.03 or  $-30$  db., and the maximum phase angle  $\theta$  (see Fig. 6b) about  $2^\circ$ . At 2,000 kc/s, however, the ratio could be 0.45 or  $-7$  db., and the angle  $\theta$ ,  $24^\circ$ . On this basis, therefore, it would appear that the attenuation of the circuit must be constant within  $\pm 0.3$  db. at frequencies up to about 500 kc/s, and that above this frequency the attenuation may depart from the average value below 500 kc/s by an increasing amount up to about  $\pm 3.2$  db. at 2,000 kc/s. In addition the phase angle must be linear to within

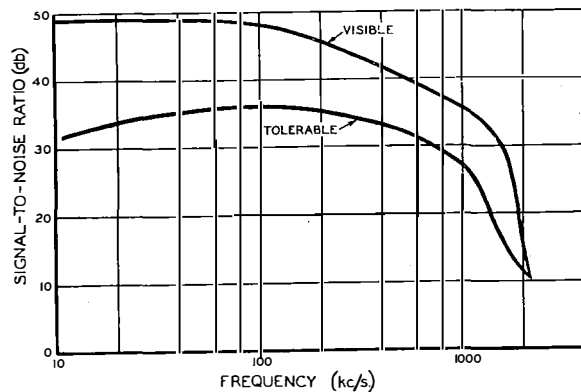

FIG. 7.—INTERFERING EFFECT OF SINGLE FREQUENCY NOISE.

$\pm 2^\circ$  at all frequencies up to 500 kc/s, and above this frequency may show an increasing departure from linearity up to about  $\pm 24^\circ$  at 2,000 kc/s. In terms of phase delay these figures indicate the following approximate permissible variations from average phase delay at different frequencies.

Frequency kc/s	Permissible departure from average phase delay in micro-seconds
10	$\pm 0.55$
20	$\pm 0.28$
50	$\pm 0.11$
100	$\pm 0.05$
250	$\pm 0.02$
500	$\pm 0.01$
1,000	$\pm 0.02$
2,000	$\pm 0.03$

It should be noted in connection with the above figures that the tolerable limits of interference at frequencies above 1,000 kc/s were probably too high, as the focus of the monitoring receiver employed in their determination was not perfect. The above figures have been based on the maximum tolerable relative level of single frequency interference and must be

reduced by about 13 db., i.e., a ratio of 4.5, if the interfering effect of the imperfect transmission at frequency  $f_1$  is to be imperceptible (see Table No. 1).

TABLE NO. 1  
THE INTERFERING EFFECT OF SINGLE FREQUENCY INTERFERENCE

Frequency of interference (approx.) kc/s	Signal/Noise Ratio (db.)	
	Visible	Tolerable
20.25	49	34
101	48	36
500	40	32
1,000	36	27
1,500	31	17
2,000	17	11

(See Note 1)

Note 1.—The tolerable level was largely determined by the general increase in brightness of the picture due to the presence of the noise, which suggests that the focus of the receiving tube was not good enough to make the effects of this frequency interference fully apparent.

The pictures formed by black and white vertical bars represent rather extreme cases, particularly when the width of the bars is only a few spot widths. In the latter case a large amount of energy is concentrated at high frequencies, but in the average type of picture the high frequency energy is comparatively small, and in this case greater tolerances in the attenuation and phase response at high frequencies may be permissible. Before this aspect of the problem can be fully analysed a thorough investigation of the energy distribution in the frequency spectrum of television signals is necessary.

In the above method of estimating the limits allowable for attenuation and phase distortion it was assumed that only the fundamental of the rectangular periodic picture signal was imperfectly transmitted. If two or more harmonics are imperfectly transmitted it is clear that the "virtual interfering components" (i.e., the components represented by the vector BA in each case) must be examined at all the frequencies of imperfect transmission and the resultant of these components determined. It is probable that an investigation on these lines would show that the limits determined by considering only one imperfectly transmitted component were sometimes on the high side, particularly at the lower end of the frequency spectrum. The fact that only one imperfectly transmitted frequency has been considered is offset, however, by the nature of the picture considered in the above analysis. This consisted of black and white vertical bars of such width that the fundamental frequency produced by scanning them was equal to the imperfectly transmitted frequency. A large percentage of the picture energy was thus concentrated at the imperfectly transmitted frequency.

*Examination of the Required Transmission Limits from the Transient Point of View.*

So far the determination of the required transmission limits has been considered by examining the

effect of various circuit conditions on the transmission of periodic signals. The problem can also be examined by considering the response of a circuit to a suddenly applied unit voltage, and this method of approach will now be considered briefly, as this method has some considerable advantages.

It is shown in Fourier integral analysis<sup>7</sup> that any transient time function encountered in practice can be represented by—

$$f(t) = \int_{-\infty}^{+\infty} g(\omega) d\omega \epsilon^{j\omega t} \dots\dots\dots(3)$$

and that  $g(\omega)$  can be expressed in terms of  $f(t)$  by the relation:—

$$g(\omega) = \frac{1}{2\pi} \int_{-\infty}^{+\infty} f(t) dt \epsilon^{-j\omega t} \dots\dots\dots(4)$$

$g(\omega)$  is, in general, a complex function of the angular frequency  $\omega$ .

The restrictions on the form of  $f(t)$  for the above to apply are:—

(a) The function  $f(t)$  must be continuous over all intervals of finite lengths. At points of discontinuity, say  $t = a$ , the value of the function shall be understood to be the arithmetic mean, i.e.

$$f(a) = \frac{1}{2} \{ f(a - 0) + f(a + 0) \}$$

(b) The integral of the magnitude  $f(t)$  over the region  $-\infty < t < +\infty$  must be finite, i.e.

$$\int_{-\infty}^{+\infty} |f(t)| dt \text{ must exist}$$

Now consider the network shown in Fig. 8. It is

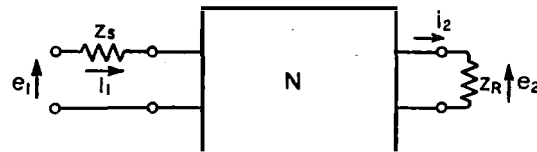

FIG. 8.—DIAGRAM ILLUSTRATING THE MEANING OF THE COMPLEX TRANSFER ADMITTANCE FUNCTION.

generally required to know the response of this system in terms of the output voltage or current time functions  $e_2(t)$  or  $i_2(t)$  for an arbitrary time function  $e_1(t)$  impressed in the transmitting branch. It is easily shown<sup>8</sup> that if

$$e_1(t) = \int_{-\infty}^{+\infty} g(\omega) d\omega \epsilon^{j\omega t} \dots\dots\dots(5)$$

$$\text{then } i_2(t) = \int_{-\infty}^{+\infty} g(\omega) \cdot Y_{12}(\omega) \cdot d\omega \cdot \epsilon^{j\omega t} \dots\dots(6)$$

<sup>7</sup> *Communication Networks, Guillemin, Vol. 2, p.468.*

<sup>8</sup> *Ibid, p. 475.*

where  $Y_{12}(\omega)$  is the complex transfer admittance function determined from the network parameters and the terminal impedances in the usual manner.

Now suppose that  $e_1(t)$  has the form shown in Fig. 9. It can then be shown that

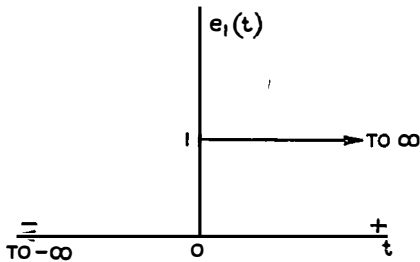

FIG. 9.—DIAGRAM ILLUSTRATING THE FORM OF THE UNIT IMPULSE VOLTAGE.

$$e_1(t) = \frac{1}{2\pi j} \int_{-\infty}^{+\infty} \frac{\epsilon^{j\omega t}}{\omega} \cdot d\omega \dots\dots\dots(7)$$

$$= \frac{1}{2} + \frac{1}{2\pi} \int_{-\infty}^{+\infty} \frac{\sin \omega t}{\omega} \cdot d\omega \dots\dots\dots(8)$$

$$\text{and } i_2(t) = \frac{1}{2\pi j} \int_{-\infty}^{+\infty} \frac{Y_{12}(\omega)}{\omega} \cdot \epsilon^{j\omega t} \cdot d\omega \dots\dots\dots(9)$$

=  $A_{12}(t)$  say

This last expression  $A_{12}(t)$  may be called the "indicial transfer admittance" between the input and output meshes of the circuit.

The problem is now whether, if the form of  $A_{12}(t)$  is known,  $Y_{12}(\omega)$  can be determined from it.

It is shown by Carson<sup>9</sup> that for any other form of  $e_1(t)$  setting in at time  $t = 0$ , the current  $i_2(t)$  is given by

$$i_2(t) = A_{12}(0) \cdot e_1(t) + \int_0^t A'_{12}(\tau) \cdot e_1(t-\tau) d\tau \dots\dots(10)$$

$$= e_1(0) \cdot A_{12}(t) + \int_0^t \dot{e}_1(t-\tau) \cdot A_{12}(\tau) d\tau \dots\dots(11)$$

where the dash suffixes represent differentiation with respect to time.

Suppose now that  $e_1(t)$  is in the form of a sine oscillation at angular frequency  $\omega$ , commencing at time  $t = 0$ , e.g.

$$e_1(t) = e_1 \sin(\omega t + \phi) \text{ from } t = 0 \text{ to } t = \infty.$$

Then the final steady state current resulting at time  $t = \infty$  is seen from equation (10) to be

$$i_2 = e_1 \sin(\omega t + \phi) \left[ A_{12}(0) + \int_0^\infty \cos \omega \tau \cdot A'_{12}(\tau) d\tau \right. \\ \left. - e_1 \cos(\omega t + \phi) \int_0^\infty \sin \omega \tau A'_{12}(\tau) d\tau \right] \dots\dots(12)$$

From equation (11) we obtain

$$i_2 = e_1 \cos(\omega t + \phi) \cdot \omega \int_0^\infty \cos \omega \tau A_{12}(\tau) d\tau \\ + e_1 \sin(\omega t + \phi) \cdot \omega \int_0^\infty \sin \omega \tau A_{12}(\tau) d\tau \dots\dots(13)$$

providing  $A_{12}(t) \rightarrow 0$  as  $t \rightarrow \infty$ , or in other words providing there is no D.C. transmission. If there is D.C. transmission equation (12) must be employed to account for this.

Now suppose the complex transfer admittance function between the input and output meshes of the network is

$$Y_{12}(\omega) = \alpha(\omega) + j\beta(\omega) \text{ say } \dots\dots\dots(14)$$

$$\text{Then } i_2 = \left[ \alpha(\omega) + j\beta(\omega) \right] e_1 \sin(\omega t + \phi) \\ = e_1 \alpha(\omega) \sin(\omega t + \phi) + e_1 \beta(\omega) \cos(\omega t + \phi) \dots\dots\dots(15)$$

Comparing equations (12) and (15) we have

$$\alpha(\omega) = A_{12}(0) + \int_0^\infty \cos \omega \tau \cdot A'_{12}(\tau) \cdot d\tau \dots\dots(16)$$

$$\beta(\omega) = - \int_0^\infty \sin \omega \tau \cdot A'_{12}(\tau) \cdot d\tau \dots\dots\dots(17)$$

and by comparing equations (13) and (15) we have

$$\alpha(\omega) = \omega \int_0^\infty \sin \omega \tau A_{12}(\tau) \cdot d\tau \dots\dots\dots(18)$$

$$\text{and } \beta(\omega) = \omega \int_0^\infty \cos \omega \tau \cdot A_{12}(\tau) d\tau \dots\dots\dots(19)$$

It is thus clear that the complex transfer admittance function,  $\alpha(\omega) + j\beta(\omega)$ , can be determined from the indicial transfer admittance,  $A_{12}(t)$ , providing the above integrals can be evaluated.

Such integrals can be evaluated by the inter-graphs of T. S. Grey and S. Bush<sup>10</sup>, or by harmonic analysers of continuously adjustable basic length as described by G. V. Bekeşy<sup>11</sup>. Bekeşy actually discusses the determination of the frequency variability of transmission systems by transients according to the above theory. Dr. N. W. J. Lewis of the P.O. Engineering Department has suggested that Hollerith calculating machines,<sup>12</sup> which are of the punched card type and include automatic reproducing punches and summary multipliers, should be used for analysing indicial transfer admittance characteristics. No study has yet been made by the Post Office of the relative advantages and disadvantages of the various

<sup>9</sup> *Electric Circuit Theory and the Operational Calculus.*

<sup>10</sup> *J. Franklin Inst.*, Vol. 77, pp. 77 and 477.

<sup>11</sup> *Akust. Zeits.*, Sept., 1937.

<sup>12</sup> *P.O.E.E.J.*, Vol. 32, p. 94.

methods available for analysing these characteristics.

Dr. Lewis has suggested that limits could be imposed on the indicial transfer admittance characteristic of a television circuit, and from these the limits of the attenuation and phase components of the steady state transfer admittance could be determined by one of the methods suggested above.

The nature of the limits which could be applied to the indicial transfer admittance characteristic will be considered briefly. Referring to Fig. 10 it is

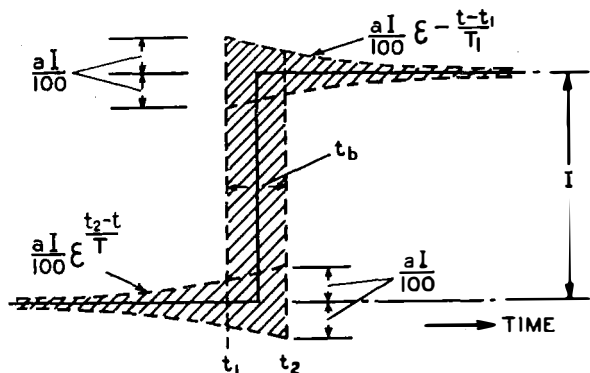

FIG. 10.—LIMITS TO THE INDICIAL TRANSFER ADMITTANCE FUNCTION NEAR THE BUILD-UP PERIOD.

clear that the following aspects of the indicial transfer admittance will have to be specified :—

- (a) Build-up time.
- (b) Overswing.
- (c) Rate of decay of overswing.

Limits to these three factors can be imposed by requiring the indicial transfer admittance to lie within a shaded area such as that shown in the figure. Thus  $t_b (=t_2-t_1)$  represents the maximum build-up time allowable in order that the black and white edge shall be sharp enough to transmit the required detail.

If this build-up time is equal to the time taken to scan a distance equal to the thickness of a line (i.e., the spot width), then it is equal to

$$\frac{\alpha}{\beta} \cdot \frac{1}{n^2 f_r} \text{ seconds} \dots \dots \dots (20)$$

The factor "a" represents half the maximum permissible percentage difference of brightness in a region of uniform brightness. According to Fechner's law the minimum perceptible percentage change of brightness is about 1 per cent. over a wide range of brightness. The results of the tests of the interfering effect of single frequency and random interference, given later in the article, suggest that the maximum permissible value of 2a is of the order of 2-4.

The rate of decay of overswing is expressed by the time constant  $T_1$ . It is clear that  $T_1$  will be determined by the rate of repetition of sudden changes from black to white and vice-versa. If after a sudden change from black to white another sudden change from white to black occurs before the overswing has decayed sufficiently, the overswing on the next change may add to the previous one and will then exceed the permissible limit. It is clear that  $T_1$  will be the most difficult factor to specify as it will depend so

much on the type of picture. It may be best to specify a maximum rate of repetition of sudden changes from black to white and vice-versa and determine  $T_1$  for that rate. Owing to the necessity for doing this it is doubtful whether the analysis of the response of the circuit to the unit impulse voltage is better than the analysis of its response to rectangular wave-form signals, and in some respects the latter is definitely preferable.

In the example shown in Fig. 10 it was assumed that the D.C. component of the signal was transmitted by the system. When this component is eliminated by the system the indicial transfer admittance will be in the form of a pulse as indicated in Fig. 11.

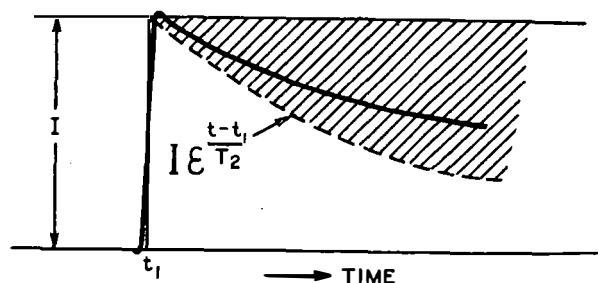

FIG. 11.—LIMITS TO THE INDICIAL TRANSFER ADMITTANCE FUNCTION AFTER THE BUILD-UP PERIOD.

The slowly decaying part of this pulse must lie somewhere in the shaded area indicated. The time constant  $T_2$  of the exponential decay curve forming the boundary of this area will be determined either by the allowable change in brightness from one side to the other of the picture, when the brightness of the transmitted picture is uniform, or by the properties of the circuit employed for reconstituting the D.C. and low frequency components. If perfect rectifiers were employed in the latter circuit the former requirement would be the only one to be considered. It has been suggested by the engineers of the Marconi-E.M.I. Television Co., that the maximum permissible change in brightness across the picture due to low frequency attenuation is 3 per cent. In the present British standard system employing 405 lines, 25 pictures per second, the duration of a line is 1/10,125 second, and the value of  $T_2$  will thus be given by

$$1 - \epsilon^{\frac{1}{10125} T_2} = 0.03$$

whence  $T_2 = 0.0033$  second.

It is now clear that if limits such as those indicated by the shaded areas in Figs. 10 and 11 are determined, then various indicial transfer admittance functions can be drawn to lie within these limits, and the limits of the complex transfer admittance function determined by the method described above. The limits of attenuation and phase response are, of course, contained in the limits of the complex transfer admittance function.

It is important to consider here the exact meaning of limits of attenuation and phase response determined in this manner. It is clear that various indicial transfer admittance functions lying within the prescribed limits will lead to various attenuation and



phase responses and possibly, at any particular frequency, the departure of attenuation or phase response from the ideal will be a maximum for a particular form of transfer indicial admittance function. Supposing that such maximum values are determinable at all frequencies it does not necessarily follow that any attenuation and phase responses lying within the envelope of these maximum limits will necessarily lead to indicial transfer admittance functions lying within the prescribed limits, assuming, of course, that the proper restrictions are placed on the attenuation and phase responses to ensure that they can exist simultaneously in a physical network. These considerations suggest that strict limitations to the maximum departures permissible in attenuation and phase response at all frequencies may not be sufficient, and that the transient time response of the circuit is the only one on which strict limitations can be conveniently placed. This aspect of the problem obviously needs further study.

There is one indicial transfer admittance function of considerable interest which will be briefly considered here, namely that of a circuit having idealised low pass filter characteristics.

The complex transfer admittance function of an idealised low-pass filter circuit can be written in the form

$$Y_{12}(\omega) = \alpha(\omega) + j\beta(\omega)$$

where over the range  $-\omega_1 < \omega < \omega_1$

$$\alpha(\omega) = k$$

$$\text{and } \beta(\omega) = \omega t_d$$

and outside this range of  $\omega$ ,  $\alpha(\omega) = 0$  and  $\beta(\omega)$  is therefore immaterial.

It can then be shown<sup>13</sup> that the indicial transfer admittance function is given by

$$A_{12}(t) = k \left\{ \frac{1}{2} + \frac{1}{\pi} \text{Si} \left[ \omega_1 (t - t_d) \right] \right\} \dots (21)$$

where  $\text{Si}(x) = \int_0^x \frac{\sin u}{u} \cdot du$

The form of  $A_{12}(t)$  is shown in Fig. 12. It will be noted that the major part of the indicial transfer admittance function is delayed behind the unit impulse input voltage function by the delay-time  $t_d$ .

The horizontal scale in Fig. 12 is shown in terms of  $\omega_1 t$ , and not  $t$ , in order to generalise it for any value of  $\omega_1$ . It will also be noted that unless  $t_d$  is infinite the current in the output branch will change from zero before the input voltage does so, which is obviously physically impossible. It would naturally be expected that the infinitely sharp cut-off in the  $\alpha(\omega)$  characteristic could only be obtained by the use of an infinite number of filter sections and hence of an infinite delay time.

If at the point where  $A_{12}(t) = k/2$  a tangent is drawn as indicated by the dotted line in Fig. 12, then the time interval  $\tau_a$  between the intercepts of this tangent with the time axis and the final value

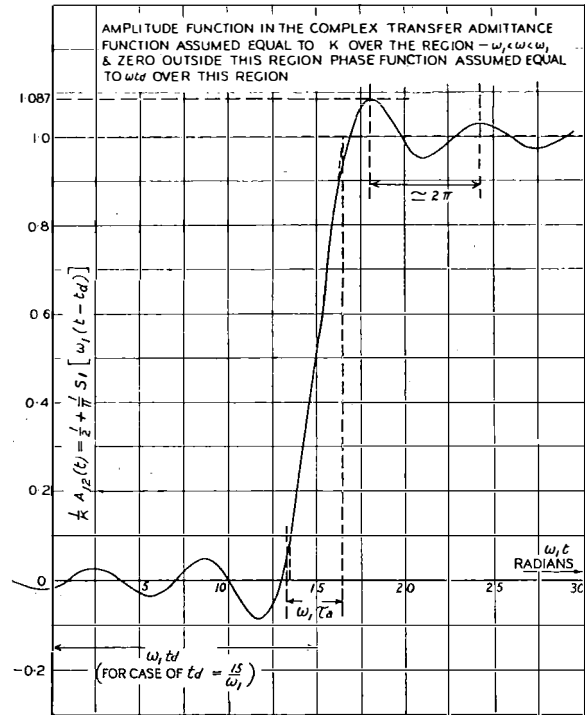

FIG. 12.—FORM OF INDICIAL TRANSFER ADMITTANCE FUNCTION OF A CIRCUIT WITH IDEALISED LOW-PASS FILTER CHARACTERISTICS.

$k$  represents what may be called the “build-up time.” It can be shown that

$$\tau_a = \frac{\pi}{\omega_1}$$

This reveals the important fact that the time of build-up is inversely proportional to the width of the transmission frequency band. If the cut-off frequency  $\omega_1$  of a television system is calculated by the formula given in equation (1), it is easily seen that  $\tau_a$  will be equal to the time taken to scan the width of a spot.

Another important feature of the indicial transfer admittance function obtained with the idealised low-pass filter characteristic is the oscillating nature of the response prior to and following the build-up period. Fig. 12 shows that oscillation occurs with a quasi period of  $2\pi/\omega_1 = 1/f_1$  seconds, and that the maximum value of  $A_{12}(t)$  is 8.75 per cent. greater than the final value. If  $f_1$  is calculated according to equation (1), it will be seen that striæ will follow a black and white picture edge, the width of the striæ being equal to the spot width. Owing to the comparatively large initial overswing such striæ would be fairly obvious at a distance close enough for the individual scanning lines to be visible. This suggests that the response obtained with a television circuit having ideal transmission characteristics up to a frequency determined by equation (1), and zero response beyond that frequency will not be by any means perfect, and suggests that some improvement in visual response may actually be produced by allowing a gradual rise of attenuation before this cut-off frequency is reached. In this way, although the

<sup>13</sup> *Communication Networks, Guilleman*, Vol. 2, p. 479.

build-up time would be increased, the oscillating nature of the indicial transfer admittance response could be reduced until it was no longer visible. It might be considered, alternatively, that the cut-off frequency given by equation (1) is inadequate, and that some appreciable response up to nearly twice this frequency is necessary if the sharpness of vertical black and white edges is to be as good as that of horizontal black and white edges, and no perceptible oscillation of the indicial transfer admittance is to occur.

#### LIMITS REQUIRED IN THE SIGNAL-TO-NOISE RATIO

Interfering noise usually falls in one of the following categories :—

- (a) Thermal agitation noise or valve noise. The frequency spectrum of the former is uniform, and of the latter is also uniform above fairly low frequencies.
- (b) Single frequency interference.
- (c) Noise from impulse excitation, in which the duration of the pulses is small compared with their time separation.

The last form of noise will not normally be encountered in well-shielded line circuits, and it is not proposed to consider it here.

The following tests have been described in detail in a previous article in this JOURNAL<sup>14</sup>, but they will be briefly summarised here as they have a close bearing on the matters already considered in this article. Vision signals derived from 405-line interlaced scanning at 25 pictures per second were employed; their quality and noise content were of the order obtained in the reception of the B.B.C. transmissions under conditions of reasonable freedom from interference. The tests consisted in mixing additional noise with such vision signals, and determining by observation of the picture :—

- (a) The level relative to the signal at which the added noise just became visible against the background of inherent noise, giving the visible signal noise ratio.
- (b) The highest level of noise relative to signal that could be tolerated without serious deterioration of the quality of the picture, or undue irritation to the observer, giving the tolerable signal/noise ratio.

As these relations are subjective, readings were taken by a number of different observers, and the average calculated.

The signal/noise ratio is expressed as the ratio of the double amplitude peak (D.A.P.) vision signal voltage to the peak noise voltage. Referring to Fig. 13, the D.A.P. vision signal voltage is the magnitude *S* of the vision signal between black and full white, synchronising pulses being excluded. The peak noise level is the single amplitude peak value *N*.

The average results of a considerable number of tests made by several observers on a variety of different pictures were as follows :—

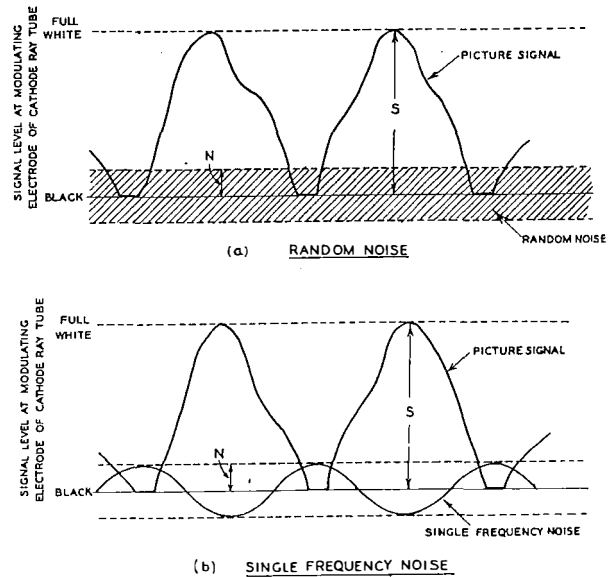

FIG. 13.—METHOD OF EXPRESSING SIGNAL NOISE RATIO.

Visible signal/noise ratio = 35 db.  
Tolerable signal/noise ratio = 28 db.

Tests were also made to determine the lowest level of noise visible on a uniformly illuminated raster<sup>15</sup> in the absence of a vision signal, the masking effect of the noise inherent in the vision signals previously employed being thus obviated. In order that the results should be comparable with those of the preceding tests, the noise level was expressed in relation to the level of the vision signal required to give a good picture on the particular cathode-ray tube used. The average value obtained for the signal/noise ratio at which the noise was just visible was 42 db.

Tests were carried out on the lines described above to determine the "visible" and "tolerable" signal/noise ratios for single frequency interference at frequencies from 20 kc/s to 2 Mc/s. The interference was found to be most objectionable at frequencies equal to, or close to, multiples of the line frequency. The pattern then consisted of vertical bars, alternately black and white, the number of pairs of bars in the width of the picture being equal to the ratio of the interfering frequency to the line frequency. The bar pattern was either stationary or drifting slowly across the picture.

The results for a series of such frequencies are given in Table No. 1 and Fig. 7. It will be seen that the signal/noise ratio at which the noise just became visible decreased from 49 db. to 17 db., and the tolerable signal/noise ratio from 34 db. to 11 db. as the frequency of the noise was increased from 20.25 kc/s to 2,000 kc/s. This reduction may have been partly due to imperfection of focus in the tube of the receiver used, partly to the greater masking effect of the existing random noise at the higher frequencies, and partly to the fact that the finer grain of the interference pattern at the higher

<sup>15</sup> The series of illuminated lines produced on a screen when scanning with an electron beam.

<sup>14</sup> P.O.E.E.J., Vol. 32, p. 193.

frequencies makes it less visible at the normal viewing distance.

No tests were made to determine the level at which single frequency interference became visible on a uniformly illuminated raster in the absence of signal. In view of the regular nature of the interference patterns, however, it is probable that the noise inherent in the vision signals had little masking effect at the lower frequencies.

Fechner's law states that the minimum perceptible percentage difference of brightness is nearly constant and equal to about 1-2 per cent. over a wide range of brightness. A minimum perceptible percentage difference of brightness of 1 per cent. would mean that the ratio of the double amplitude peak magnitude of the signal to the peak magnitude of the noise at which the noise was just visible would be 46 db. This figure is in good agreement with the average figure of 46 db. obtained experimentally with single frequency interference having a frequency up to 500 kc/s.

#### OVERALL GAIN STABILITY

As already stated, the minimum perceptible percentage change of brightness is nearly constant over a wide range of brightness and equal to about 1-2 per cent., corresponding to a db. ratio of 0.1-0.2 db. The maximum tolerable change of brightness is probably of the order of  $\pm 1$  db., but it is thought that a brightness stability of  $\pm 0.5$  db. is desirable and perhaps closer than this if the gain changes are fairly rapid. The permissible figures of gain stability will depend on whether the black level is fixed in the receiver (e.g., by D.C. restoration from the black level), or whether the bottom of the synchronising pulses is the fixed level, as is normal at present, when a gain stability better than  $\pm 0.5$  db. is probably essential for a good service. Experiments to determine these limits more definitely are obviously desirable.

#### NON-LINEAR DISTORTION

A fair amount of effective non-linear distortion occurs in the normal cathode-ray television receiver due to the non-linear relation between spot brightness and modulator grid bias. This distortion is usually such as to increase the light parts of the picture relative to the darker parts, and it has been stated that this is desirable with small pictures owing to the fact that the contrast sensitivity of the eye is reduced by a reduction in the size of the field of vision.

In a line transmission circuit non-linear distortion would generally be opposite to this, i.e., such as to decrease the relative brightness of the light part of the picture. If the synchronising signals are transmitted with the picture signal, and D.C. modulation is not employed, then the necessary limits of non-linear distortion will be much closer than they would be if D.C. modulation were employed, because non-linear distortion would result in changing amplitude of the synchronising pulses and also changing brightness in fixed parts of moving pictures. Changing amplitude of synchronising pulses is very undesirable if the bottoms of the pulses are to be employed for D.C. restoration in the receiver, although

this difficulty could be overcome in a line circuit by D.C. restoration at the receiving end of the line from the black portion of the signal following the line synchronising pulse, the lengths of the synchronising pulses being levelled in a subsequent correcting circuit.

No definite figures are known for the non-linear distortion permissible in the overall circuit. It would probably be best to define limits for this overall non-linear distortion of the system by defining graphically limits to the output versus input voltage characteristic.

So far only the non-linear distortion of a direct transmission circuit has been considered, in which the input video signals occupy the same position in the frequency spectrum throughout the transmission. In a coaxial cable system, however, the input video frequency band is raised, and sometimes inverted. The line transmission and the modulating and demodulating processes at the transmitting and receiving ends of the line may result in components appearing in the final output video signal with frequencies which were not present in the original signal and which do not bear a harmonic relation to the latter frequencies. These unwanted products will have the same effect as noise on the picture and they must be considered as part of the total noise in the circuit. The limitations which must be applied to them are therefore the same as those outlined in connection with other types of noise, taking into account noise already existing from other sources.

#### Conclusions.

The conclusions arrived at so far regarding the desirable limitations to be imposed on the characteristics of television circuit will now be briefly summarised.

First, it is now clear that to obtain the same definition in the horizontal direction as in the vertical all frequencies must be transmitted without appreciable loss up to the frequency given by equation (1).

In the Marconi-E.M.I. system transmissions from Alexandra Palace this frequency was 2.88 Mc/s. A sharp cut-off at this frequency will lead to striæ following a black and white edge which may be visible at a distance where the lines can be distinguished, and a gradual cut-off above this frequency may be desirable in the ideal case.

Practical experience suggests that an attenuation response flat to within  $\pm 0.5$  db. up to at least 500 kc/s is desirable, although satisfaction appears to have been expressed with the results of line tests in other countries where the variation was of the order of twice this value. A great deal depends on the type of picture employed in testing, pictures containing sharply-defined black and white edges needing much better transmission conditions, particularly at higher frequencies, than pictures containing only gradual changes.

Apart from the direct experimental determination of the effect of various transmission conditions on picture quality, three indirect methods of assessing the allowable limits of the attenuation and phase

response of the circuit have been examined.

A preliminary examination of a method based on the interfering effect of unwanted components introduced by attenuation and phase distortion suggests that the attenuation should be kept flat to within  $\pm 0.3$  db. at frequencies up to 500 kc/s, and above this frequency may be allowed to depart by an increasing amount up to about  $\pm 3.2$  db. at 2,000 kc/s. On the same basis the phase shift must be kept linear to within  $\pm 2^\circ$  at all frequencies up to 500 kc/s, and above this frequency may show an increasing departure from linearity up to about  $\pm 24^\circ$  at 2,000 kc/s. These limits must be divided by about 4 if the circuit is to show no perceptible picture distortion for any type of picture.

A preliminary examination of a second method of determining the necessary limits of attenuation and phase response has also been made depending on the response of the circuit to signals of rectangular waveform. Limits to the shape of the received waveform should be based on build-up time at black and white edges and the maximum tolerable percentage brightness difference in regions which should be of uniform brightness. It is suggested that in order to obtain equivalent definition in the horizontal and vertical directions the build-up time must not exceed the time taken to scan a distance equal to the thickness of a line. The maximum tolerable percentage brightness difference in regions which should be of uniform brightness is probably about 3-5 per cent., this figure being based on the interfering effect of single frequency interference.

By harmonic analysis of received waveforms lying within these limits it may be possible to prescribe limits of attenuation and phase response of the circuit, but difficulties may arise here as mentioned below.

The subject has also been studied from the point of view of the transient response of the circuit to a suddenly applied voltage, and it has been shown how limits can be applied to the response characteristic, based, as in the second method, on build-up time and maximum tolerable percentage brightness difference in regions which should be of uniform brightness. Unfortunately, a third limit must be placed on the transient response characteristic, namely, the rate of decay of overswing. It appears that this can only be determined from a knowledge of the rate of repetition of black and white edges in the picture.

It has been shown how the limits of attenuation and phase response might be determined from the limits of the transient response characteristic, but difficulties may arise here. It appears that limitations in simple form may only be applicable strictly to the response to square waveform signals, or the transient response, and that it may not be possible to apply them strictly to attenuation and phase response.

In all these methods of determining the permissible limits in the attenuation and phase response of the circuit, pictures have been considered involving sharp black and white edges, and on this account the limits derived from them may be closer than those

which are necessary in pictures involving few sharp changes in brightness.

Limits to the minimum signal to noise ratio permissible with either random noise or single frequency noise have been determined experimentally. The ratio of the double amplitude peak signal level (excluding synchronising pulses) to the peak noise level at which the noise is just perceptible in the absence of other noise is about 42 db. for random noise and about 49 db. for single frequency noise of frequencies below 500 kc/s, and decreasing for higher frequencies. Both types of noise can be raised about 14 db. above these respective levels before becoming intolerable.

It is suggested that overall gain stability of at least  $\pm 0.5$  db. is necessary, and better than this if D.C. modulation is not employed, or D.C. restoration carried out from the black level.

Limits of non-linear distortion in circuits not employing any frequency translation should be defined graphically. Where frequency translation occurs, components at frequencies not present in the original signal may be produced, and these must be regarded as additional noise in the picture.

It is now clear that the limitations which must be applied to a television circuit are much closer than those necessary in a telephony or music circuit. In transmission of music the first essential is that the output frequencies shall be the same as the input frequencies, and that no additional frequencies of appreciable magnitude shall be introduced. Providing these limitations are met no discords are possible, and fairly wide variations (of the order of  $\pm 3$  db.) in the attenuation response of the system are permissible without appreciable effect on the results. Considerable variations may occur, for instance, due to room reflections in the room when the music is reproduced. In addition, the phase response of the system is of little importance for music transmission. For television signals, however, not only must the output frequencies be exactly equal to the input frequencies, but the variation of the amplitude of the output signal with time must be closely proportional to the variation of the input signal with time, as the eye is able to perceive brightness differences as low as 1 per cent. The result of this is that very close limits of both attenuation and phase response are necessary in a television circuit, in addition to the fact that the frequency bandwidth required for reasonable definition is about 250 times as great as that required in a good music circuit. Even from the present rather scanty data on this subject it is now clear that very close transmission limits are essential in a television circuit if the result is to be comparable with present cinema standards.

The difficulties in obtaining such close limits with existing components and technique, especially on long circuits, will mean that the future development of television will depend to a considerable extent on the development of new types of valves and, perhaps, also on the development of the technique of the use of the very high radio frequencies.

# Melbourne City West Exchange

W. CORNELL and B. DRAPER  
(The General Electric Co. Ltd.)

U.D.C. 621.395.34 621.395.658 621.395.722

A general description is given of the equipment provided at the City West Exchange, Melbourne, with more detailed information where this equipment differs from standard British Post Office practice. Of interest is a new uniselector used for the subscriber's line switch which enables 300 circuits to be mounted on a standard rack.

## Introduction.

THE city of Melbourne, with a population of approximately one million, the second largest city in the Commonwealth of Australia and the capital of the state of Victoria, has nearly 100,000 telephone lines within a single fee network. A very large proportion are connected to automatic exchanges, but the central business part of the city was, until recently, served by a central battery manual exchange opened in 1911. The natural growth of a thriving community has made it necessary to revise this part of the city layout by dividing it into two exchange areas of approximately equal size and known as City West and City East respectively. City West received attention first and an order for the automatic exchange to bear that name was placed with The General Electric Co., Ltd. The switching equipment, which has an initial capacity of 6,000 lines, employs B.P.O. type 2000 selectors, with uniselectors in the subscribers' line circuits.

City West is the largest automatic exchange in the Melbourne network, which has over 50 exchanges, and is defined by a radius of 15 miles from the G.P.O.

## Building.

The building which accommodates City West exchange has seven floors and a basement and is of modern fireproof construction. It stands on a site 102 ft. by 65 ft. and three floors and the basement are occupied by the exchange equipment. The floors are of mushroom construction, that is to say, I-beams of the conventional type are not employed, but rod reinforcements branching radially from floor columns are used for the purposes of affording general reinforcement to the floors. Thus, except for a small amount of "spreading" at the top of the column, the ceiling is left entirely clear of obstruction. An illustration showing this method of reinforcement is given in Fig. 1. A particularly interesting fact is that the total floor thickness is only 10 ins.

## Trunking Diagram.

The Melbourne system is of the non-director, direct dialling type, utilising five- and six-digit numbers, of which the first one or two digits respectively are expressed as letters. The call letter for City West is M. The trunking diagram in Fig. 2 shows a provision for 6,000 lines initially with a final-selector multiple of 7,000 lines.

The levels M1000—M4000 are reserved for P.B.X. services and MU1000—MU3000 for regular lines. All group selectors have 20 outlets per level with the exception of the "M07" and "M09" 4th selectors, where the outgoing circuits connected are few and 10 outlets prove sufficient. The 2/10 P.B.X. final selectors are of 100-line capacity and are provided on the basis of 30 switches and 40 banks per 100 subscribers' lines. Regular final selectors are of 200-

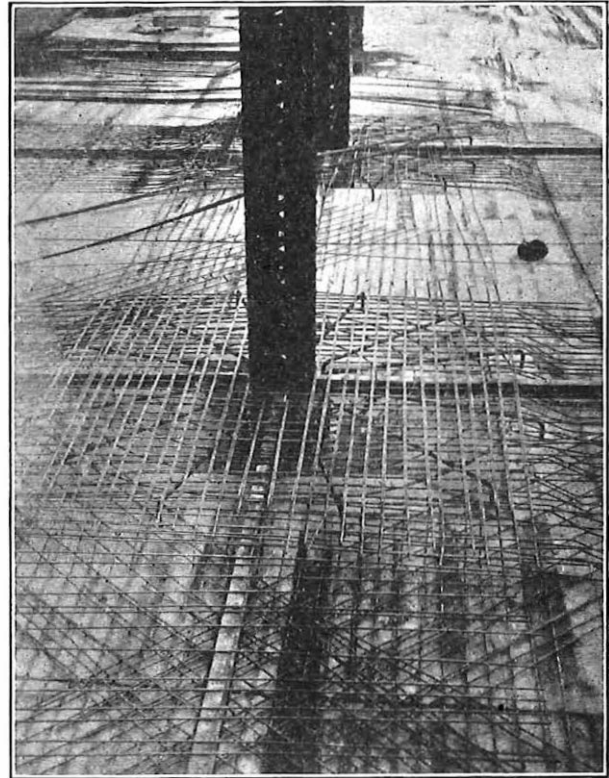

FIG. 1.—METHOD OF FLOOR REINFORCEMENT.

line type and 16 switches and 20 banks are provided per 200 subscribers' lines.

The larger P.B.X. groups are connected to special P.B.X. final selectors, the contacts of which terminate ten lines on each level and are graded to serve groups of more than ten lines.

There are two exchanges, viz. Footscray (MW) and South Melbourne (MX) in which much of the originated traffic is outgoing. In consequence they are arranged as satellites, and all their outgoing traffic is routed to 1st selectors at City West.

The banks of the 1st selectors are graded to the outgoing junction relay sets appropriate to each level, with the exception of level 6, which is connected to the local 2nd selectors.

For the sake of simplicity, the trunking diagram shows the local and incoming 1st selector bank levels tied together, but in practice it is found more convenient to grade the local and incoming banks separately if the total number of junctions for a level exceeds about 150.

Local calls from City West subscribers are completed by dialling via the 2nd, 3rd and 4th group selectors to the final selectors, transmission feed to the called party being applied by the final selector through

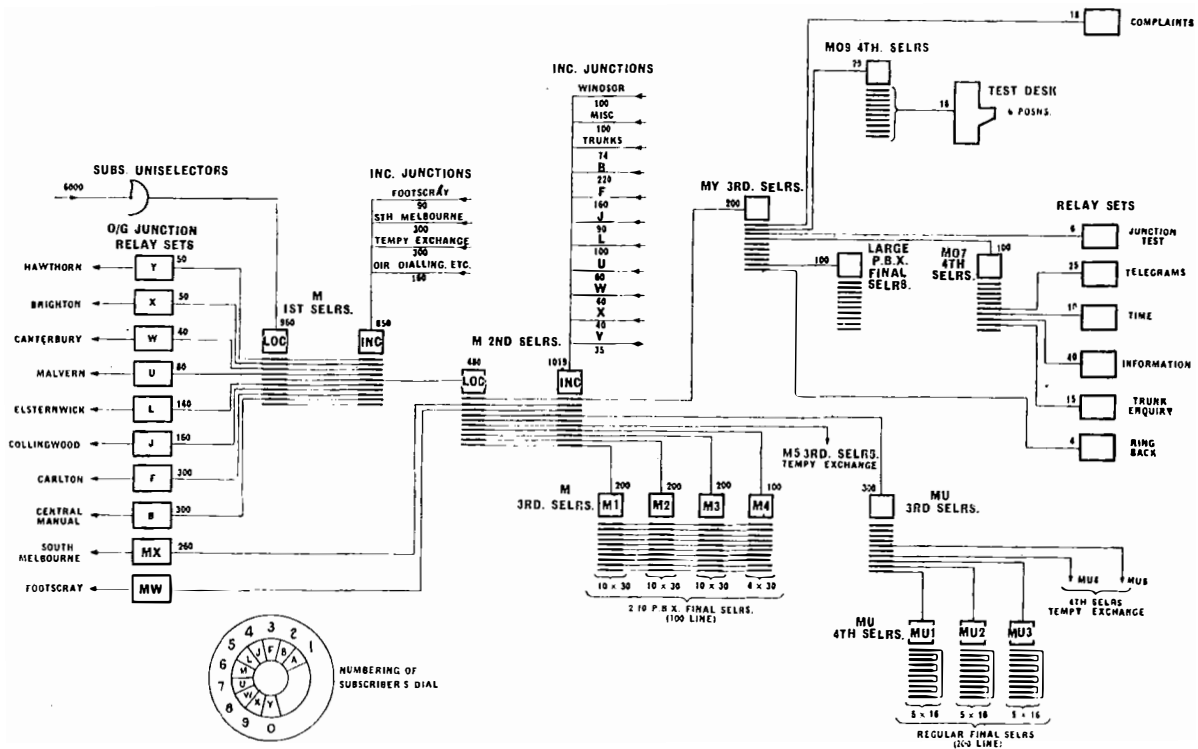

FIG. 2.—TRUNKING DIAGRAM.

ballast resistors. The final selectors are arranged for last party release, the chief purpose of which is to prevent a called subscriber from seizing and holding a first selector should he restore his receiver later than the calling party.

Junctions incoming from other automatic exchanges are terminated direct on 2nd selectors, the first digit being dialled on selectors at the originating exchange. At "Windsor" and "Trunks," which are both manual exchanges, the operators have direct junctions to City West and can therefore dispense with the first digit.

The subscriber's numbering on the large P.B.X. services is as follows:—

- MY 210
- MY 220
- MY 230, etc.

Ten different subscribers can thus be accommodated for each rank of final selectors. It should be noted that the last digit 0 does not control the final selector rotation but is absorbed by the A relay. The purpose in inserting it in the subscriber's number is to maintain five-digit numbers.

Relay sets shown on the right-hand side of the trunking diagram are associated with the special services, of which the following are provided and serve the whole Melbourne network.

- Telegrams M075
- Time M074
- Information M073
- Trunk enquiry M072
- Junction test M08

Complaints M00, and ring-back M01, are used by City West subscribers only.

The subscriber's line circuits are cabled to the local side of the I.D.F. to permit an even distribution of traffic over each graded group. Five unselector racks, i.e., 1,500 circuits, are graded into three selector racks accommodating 80 selectors each, there being four such groups initially.

The main equipment provided at present is as follows:—

- 6,000 subscribers' line circuits.
- 4,854 20-outlet group selectors.
- 120 10-outlet group selectors.
- 1,020 2/10 P.B.X. final selectors, 100 line.
- 240 regular final selectors, 200 line.
- 100 large P.B.X. final selectors.
- 1,530 outgoing junction relay sets.

*Subscriber's Dial.*

The trunking and its association with the numbering scheme is related to the numbering of the subscriber's dial. This is shown in Fig. 2, from which it will be seen that each hole in the finger-plate is allotted a digit and a letter.

*Auto-to-Auto Junction Relay Sets.*

It will be observed that a considerable number of outgoing auto-to-auto relay sets is required for junction working. It frequently happens that three such relay sets are required to work in tandem and a considerable amount of effort was expended in developing a circuit that would perform the required functions with the minimum of adjustment and maintenance of apparatus. By employing the latest technique in the way of ballast resistors in the transmission feed, high-impedance low-resistance A relays, and the use of copper-oxide rectifiers across the shunt-

field relay coil, an extremely efficient circuit was produced. It operates over the whole range of junction resistances normally met with in the area, without the need for each relay set to be adjusted specially to suit the junction to which it is applied. The circuit eliminates the distortion sometimes associated with the first impulse in a train and prevents "pick-up" trouble within the impulsing range.

#### LAYOUT AND CABLING

The automatic switching equipment is arranged on the basement, ground, first and second floors of the building.

The basement accommodates the power plant, the ground floor contains the M.D.F. (Fig. 3),



FIG. 3.—THE MAIN DISTRIBUTION FRAME.

test desks, P.B.X. power panel, and battery room. On the first floor are the subscribers' I.D.F., uniselector racks, final selector racks, meters, and third and fourth group selectors forming the City West exchange. The second floor is equipped with the first selectors, second selectors, and outgoing relay sets required for working the area. The third floor is reserved for City East exchange and the manual board for the Melbourne area is installed on the fifth floor.

All selector racks are of the standard width of 4 ft. 6 in. and height of 10 ft. 6½ in.

The I.D.F. is located on the first floor in the same relative position as the M.D.F. on the ground floor. This permits an interesting arrangement for the cabling between the two frames. During the construction of the building, holes were prepared in the floor between each pair of uprights on the multiple side of the I.D.F., i.e., one hole per pair of uprights. The cables between the I.D.F. and M.D.F. are fed through these holes, thus reducing the length of cables and the congestion which would otherwise have occurred on the cable racks above the I.D.F.

The cable racks are built up from standard items, which consist chiefly of tyre-section runners and

slats of lighter section with the ends turned over and drilled. The slats are fixed by screws into small, tapped slugs, which fit into the section of the runner and permit the slats to be located as desired to accommodate the sections of cables dropping on to suite cable runways. Thus the racking was built up entirely during installation from pre-designed plans and could be adjusted on site to provide the most convenient cable runs.

The M.D.F., which was constructed in the workshops of the P.M.G.'s Department, Melbourne, is arranged to utilise the total available height of 16 feet. It accommodates 300 lines per vertical on the line side and 250 lines on the exchange side.

#### Uniselector Ranks.

The high calling rate (upwards of 0.1 T.U. average per line in the busy hour) coupled with certain seasonal peaks of traffic, was a factor that influenced a decision to use uniselectors for subscribers' line circuits. It was realised, too, that the simpler circuits of the uniselector system would operate more reliably with the type of traffic in the area.

In order to mount subscribers' line circuits in the most economical manner, a special rack was developed with capacity for 300 circuits in the standard width of 4 ft.-6 in. and height of 10 ft.-6½ in. The uniselector illustrated in Fig. 4 was employed to permit this. This uniselector mounts on 1½ in. centres instead of the usual 2 in., and since B.P.O. type 600 relays are used and mounted on the same centres, it was possible to accommodate 25 circuits in the width of the rack instead of 20.

A shelf unit (Fig. 5) was designed to carry two shelves, each of 25 uniselectors, with the associated 100 relays on plates between them. The full capacity of 300 lines is obtained by mounting six such units on a rack. Each unit is provided with a terminal strip for the incoming 50 lines and with a second strip for the outgoing trunks, separate terminals being provided for each shelf of 25.

From Fig. 4 it will be seen that the new uniselector is similar in appearance to its predecessor. Only one operating coil is employed, however, and this is included in a magnetic circuit of higher efficiency, with the result that the permissible voltage limits for a given nominal voltage are wider. The knife-edge suspension of the armature is adjustable to provide more positive adjustment of the armature stroke than was obtainable with the previous design, in which the operating coils themselves had to be moved to adjust armature travel. Life tests have proved that the new uniselector has a life more than equal to that of the old type, and that adjustments are retained for an even longer period than could previously be counted upon.

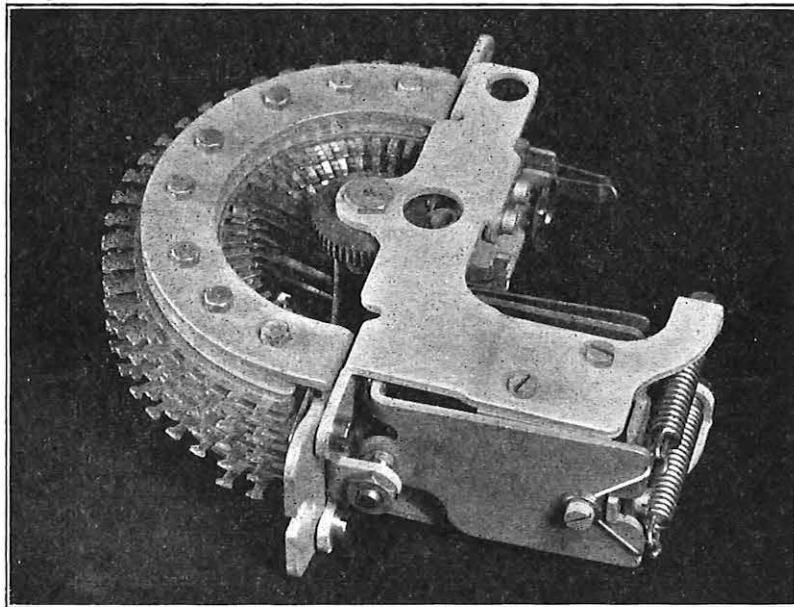
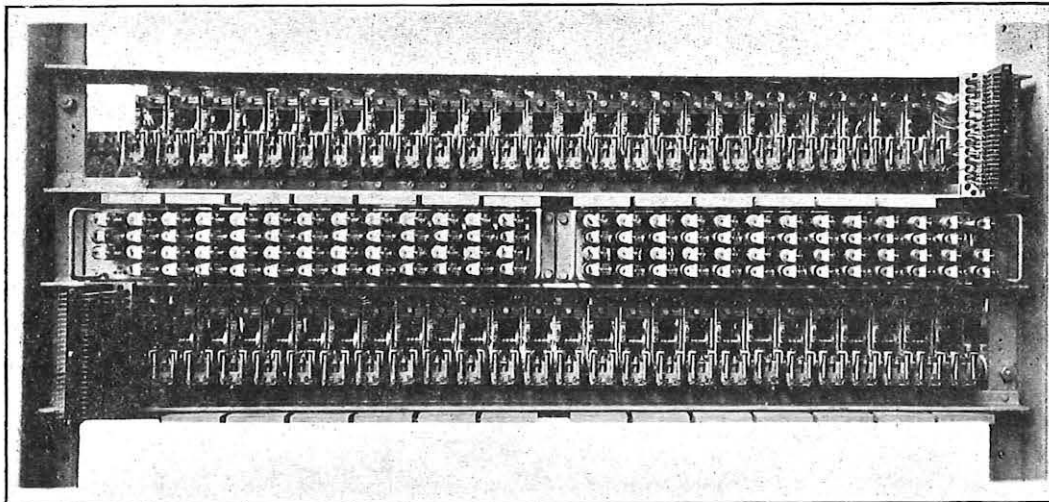

FIG. 4.—NEW SMALL TYPE UNISELECTOR.

Fig. 6 shows the subscriber's line circuit, which contains the following interesting features that are standard on exchanges in Australia :—

- (1) Automatic step-over on open trunks.
- (2) With all trunks busy, the uniselector hunts to the last contact, and returns busy tone to the calling subscriber.

For the first feature, the line circuit is so arranged that when the K relay fails to hold because of the absence of earth from a first selector, relay L is again energised but is slow to operate. In the operating period the driving magnet of the uniselector is energised, and when relay L operates, the wipers step off the open trunk. Although the second feature reduces the number of available outlets to 23, it is considered highly desirable in Australian city networks owing to the



(a) FRONT VIEW.

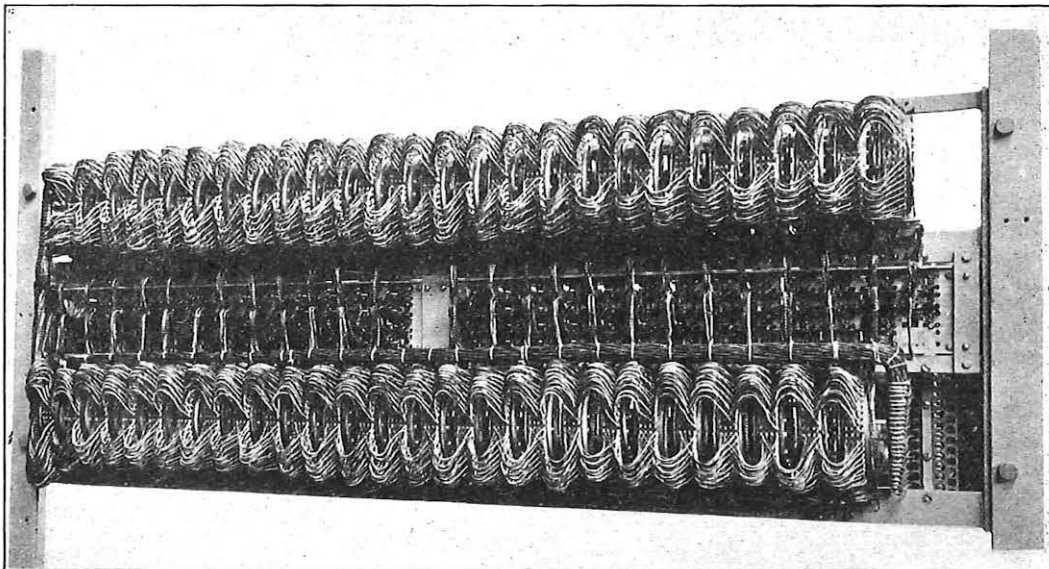

(b) REAR VIEW.

FIG. 5.—SHELF UNIT MOUNTING 50 UNISELECTORS AND L. AND K. RELAYS.





In the impulse counting circuit (Fig. 9) a uniselector is employed to count the impulses and to vary accor-

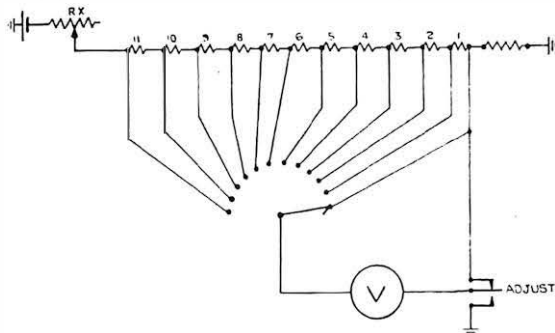

FIG. 9.—IMPULSE COUNTING CIRCUIT.

dingly the shunt across the voltmeter. With the adjust key operated and resistor RX suitably set, a deflection of 11 is obtained on the scale. The resistor remains at that setting and the adjust key is released. Receipt of the impulses steps the uniselector and the shunt it applies governs the voltmeter reading.

Two other distinctive features of the test desk are described under the following headings:—

#### *Release of Switches Held by Faulty Lines.*

This circuit is associated with the test circuit and enables the test clerk to release a switch held by a faulty line.

The line under test is dialled in the usual way over the test distributor and final selector. If the voltmeter test indicates that battery-feed relays are across the line, the circuit is challenged, and if no response to verbal enquiry is obtained, the release key is operated. Earth is connected to one side of the line under test, whereupon the earth-connected winding of relay A in the selector is short-circuited. A booster battery of approximately 54 volts is connected to the other side of the line via the low-resistance winding of relay A in the release circuit. This battery causes a slight reversal of current in the battery-connected winding of the selector A relay which consequently releases. Relay B in the selector is also released and earth is removed from the P wire. The faulty line can now be tested free from exchange connections.

The release circuit A relay acts as a guard relay and its function is to prevent the booster battery from being connected to a line which is earthed or short-circuited close to the M.D.F., when the booster battery current would be excessively high, and relay A is therefore adjusted so that it will operate to a low-resistance earth. It then holds through its 1000-ohm winding and its contacts light the pilot lamp to indicate that the selector must be released by hand.

Relay B is slow operating in order to allow relay A sufficient time to test

the line as described above and, if necessary, to open the booster battery circuit.

#### *Rectifier Circuit for 400-Volts Supply.*

A 400-volts direct supply to the test circuit, enabling the test clerk to perform insulation tests, is provided by rectifiers arranged in a voltage doubler circuit.

#### *Complaints Desk.*

Subscribers experiencing difficulty in the operation of their telephone services are instructed to dial "M00." The circuits from the 3rd selector levels terminate on the banks of a group of finder switches which are equivalent to answering circuits. A pilot lamp, which is provided on each complaints position, glows when a complaint call is received and remains lighted so long as a call remains to be answered. Callers waiting to be answered receive ringing tone, which is disconnected when the clerk answers.

Calls may be extended and metering effected by the test clerk.

The answering key connects the call to the test clerk's telephone circuit. The testing key connects the calling subscriber's line to the test circuit. The dialling key enables the test clerk to extend a call. The release key is operated if it is necessary to release an extended call owing to a dialling error. The registration control key is operated to meter the call against the calling subscriber. The guard lamp commences to glow when the test clerk is connected with a caller.

If only one call is waiting, the pilot lamp will cease to glow when the call is taken over. In the event of two or more test clerks attempting to take over the only waiting call, the guard lamp lights on the answering circuit securing the call and the extinction of the pilot lamp together with no glow on the guard lamp informs the other test clerks that the call has been taken over elsewhere. The guard lamp glows until the caller replaces his handset. The called supervisory lamp is used on extended calls. It glows

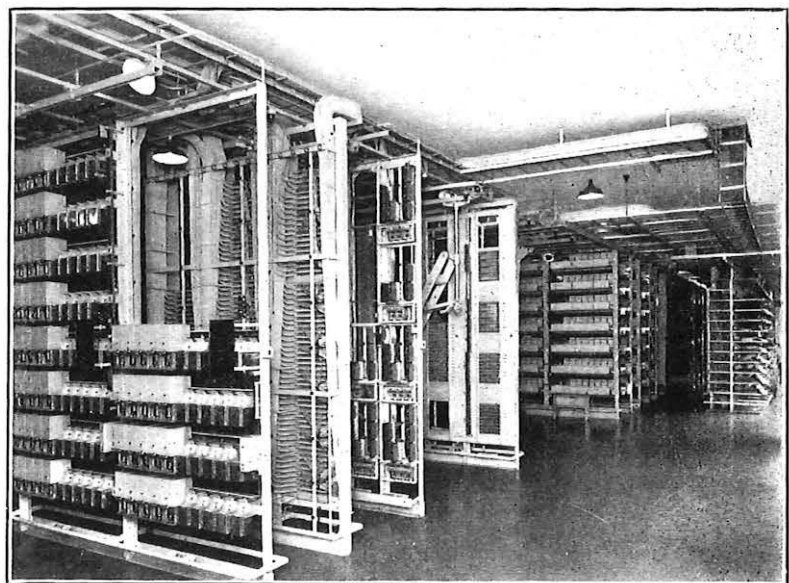

FIG. 10.—GENERAL VIEW OF FIRST FLOOR.

immediately a first selector is obtained and is extinguished when the called subscriber answers.

#### *Auxiliary Equipment.*

*Special Service on Faulty Lines.*—Equipment is provided to maintain service on faulty lines. On a line which is disconnected on one side, service is given by connecting the open line to earth at the subscriber's premises and plugging the auxiliary equipment into the faulty line, which thus becomes a single-wire earth-return circuit. On a short-circuited line, service is given by opening one side of the line at the exchange and earthing the line at the subscriber's instrument.

Dialled impulses are received over one wire of the line, which is so plugged-up that the auxiliary equipment is connected to the sound wire. A relay repeats the dialled impulses to the exchange equipment.

When calling from the exchange, the ringing condition closes a ringing circuit to the subscriber's line over the sound wire.

*Ring-Back Relay Set.*—Relay sets are installed to provide revertive calls on 2-party lines. A subscriber wishing to make such a call dials the ring-back number M01 and then replaces his handset. Connection is established from a 3rd selector to a relay set, which then feeds ringing current to the line. Both bells ring and the calling party waits for cessation of ringing, which denotes that the called party has answered, before lifting his handset again. Battery feed is supplied by the relay set.

*Centralised Observation Circuit.*—This circuit enables observations of subscribers' service for the Melbourne area to be made at City West. Up to twenty line-tapping circuits are associated with a common 4-wire junction circuit. A call is indicated by lamps on the centralised position, together with an indication of the particular line-tapping circuit in use, and means are provided for the observation operator to listen on the call. Any number of junctions may be connected to a central position but as only one at a time can be observed, any junction, after the indication has been given that a call is in progress, will be released unless the observing equipment is free at the time the call is originated.

When a junction is seized by an outgoing call, the call lamp at the observation equipment will glow if the indicating equipment is free. The equipment at the originating exchange transmits impulses to the observation centre, where a lamp glows to indicate the line-tapping circuit on which the call has originated.

The impulses dialled by the subscriber are transmitted over the junction and indicated by lamps on the observation position. By operating the observation key, the observer may listen to the conversation at any time. The call may be released right back to the line-tapping circuit by the release key. If the circuit is found to be faulty, the hold key is operated and the circuit thereby held until the maintenance officer at the exchange concerned is advised and the call taken over by him. Any junction can be cut off from the position by the isolation key.

*Centralised Interception Circuit.*—Subscribers' lines can be intercepted at the M.D.F. and incoming calls

extended to a central position. Calls outgoing from an intercepted line are connected to the exchange equipment via an impulse repeating circuit.

An incoming call for an intercepted line is extended to the centralised interception position if the position is free, and the call is indicated by a lamp. If the junction is already in use, busy tone is given to the caller.

The interception operator ascertains the requirements of the caller and deals with the call in one of two ways :—

- (a) By operating the "through" key; the call is then connected through to the called subscriber's line and the junction made free.
- (b) By operating the "lock-off" key to release the interception and junction circuits, pending the release of the exchange equipment by the caller.

#### *Floor Alarms.*

In order to call attention to a lamp indication, floor lamps and bells are provided on each floor, thus ensuring that an alarm is not overlooked should a particular floor not be staffed.

When the alarm is operated, it can be restored to its normal condition only by actually clearing the fault, except in certain non-urgent cases where the service is not dependent on prompt clearance.

#### *Power Plant.*

The float system, which has been standard in Australia for some years, is used at City West. It employs two batteries, each of which is connected to the exchange bus-bars on alternate weeks. Each battery consists of 26 cells of 4,500 Ah capacity, and is provided with a tapping at the 24th cell. Initially, two charging machines, each of 750 A, 65 V, capacity, may be connected singly or together across either battery, the voltage of the generators being controlled during the floating period by an automatic voltage regulator.

The main discharge lead may be switched to the 24th or 26th cell on either battery by a power-driven make-before-break switch of 3,200 A capacity.

When the load is insufficient to warrant the operation of the generators, the 26 cells are switched in and the battery alone then serves the exchange.

During the major portion of the day when the charging equipment is required, the generators are connected across the 26 cells, the exchange operating from 24 cells only.

When the two end cells become fully charged, the generator is connected across the exchange bus-bars with the 24-cell battery floating.

The estimated loadings of the discharge leads are as follows :—

Positive lead	3,100 A
50 V negative lead	3,100 A
Positive battery lead	10 A
P.B.X. fuse panel lead	200 A

The power distribution is by copper bus-bars suitably supported on porcelain insulators suspended from the ceiling. A circuit breaker protects the negative feed to the equipment on each floor, and fuses are used to give protection on the feeds to each suite or pair of suites.

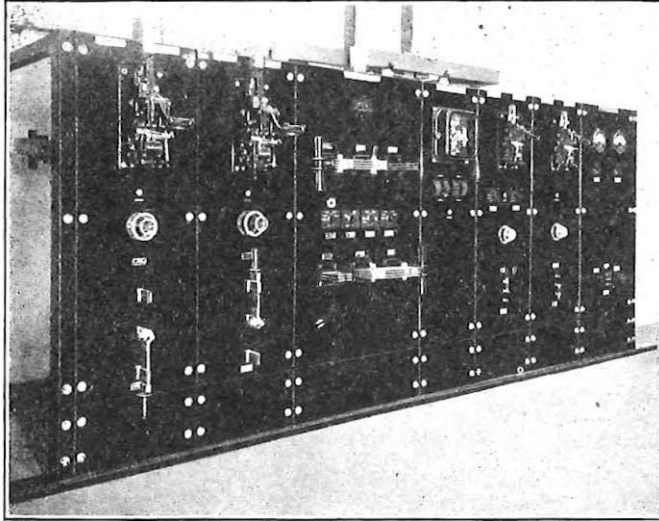

FIG. 11.—POWER BOARD.

Fig. 11 shows the power board for controlling the charging or floating of the main batteries and subsidiary equipment. A second power board, for controlling the discharge circuits, is installed on the first floor.

Two ringing and tone generators are supplied, and each has a capacity of 300 W at 75 V. One operates from the 230 V mains and the other from the exchange battery. Automatic change-over is employed in the event of a failure of output from the mains-driven machine.

The tones, which are generated by an inductor tone generator and passed to the subscriber via a third winding on the selector A relay, are noticeable by their good quality and freedom from inducing cross-talk.

### Cutting-Over.

Before the establishment of the City West exchange, the call letter M had been allocated to South Melbourne exchange; in consequence, before any subscribers could be accepted on the new equipment, it was necessary to convert South Melbourne to a branch exchange with the call letters MX. This entailed the routing of calls via incoming first selectors, second selectors, and outgoing junction relay sets at City West prior to the cutting of City West into service. It will be appreciated that each main exchange in the Melbourne network had to relinquish its junctions to South Melbourne exchange and to establish a direct route to the City West incoming second selectors without any interruption in the service. As directory number changes were involved, each conversion had to coincide with the normal directory issue, which, in Melbourne, occurs in May and November of each year.

The conversion of South Melbourne to six figure working was made in November 1937, thus enabling the initial City West subscribers' cut-over to occur in May 1938, with a further transfer of subscribers in November, 1938. The fact that some of the equipment had been in service for about a year prior to the final change-over provided a useful guide as to the liability of faults under practical conditions but it is pleasing to report that these were singularly few and no important changes were either made or contemplated in the original equipment.

### Acknowledgment

Indebtedness is expressed to The Postmaster General's Department, Melbourne, and to The General Electric Co., Ltd., for the supply of the diagrams and photographs that accompany this article.

## Addition and Subtraction Logarithms

F. ADDEY, B.Sc., F.R.A.S., M.I.E.E.

U.D.C. 518.2

Logarithms for multiplication and division are well known. The author describes and explains the use of another series of logarithms for addition and subtraction purposes.

It is sometimes necessary in the course of a computation to obtain  $\log(a + b)$  or  $\log(a - b)$  when  $\log a$  and  $\log b$  have been found at an earlier stage in the computation. This may be done without the intermediate steps of finding  $a$  and  $b$  from their logarithms, by functions known as "addition logarithms" and "subtraction logarithms."

The derivation of these functions and the methods by which they are used, are explained below.

In what follows  $a$  is assumed to be greater than  $b$ .

### Addition Logarithms.

Since  $a + b = a(1 + b/a)$ ,  $\log(a + b) = \log a + \log(1 + b/a)$ .  $\log(1 + b/a)$  is called the "addition logarithm." Addition logarithms are tabulated with  $\log a/b$ , or  $\log a - \log b$ , as argument.

### Example.

Given  $\log a = 1.93470$  and  $\log b = 1.86570$ , to find  $\log(a + b)$ .

$$\begin{array}{r} \log a = 1.93470 \\ \log b = 1.86570 \\ \hline \end{array}$$

$$\log a - \log b = 0.06900$$

Entering the table of addition logarithms with the argument 0.06900, the corresponding addition logarithm is found to be 0.26790.

Then :

$$\begin{array}{r} \log a = 1.93470 \\ \text{Adn. log} = 0.26790 \\ \hline \end{array}$$

$$\text{Sum} = 2.20260 = \log(a + b).$$

This result can be confirmed by performing the calculation without the use of addition logarithms, thus :

$$\begin{array}{r} \log a = 1.93470 \quad a = 86.04 \\ \log b = 1.86570 \quad b = 73.40 \\ \hline a + b = 159.44 \\ \log(a + b) = 2.20260 \end{array}$$

#### Subtraction Logarithms.

$$\text{Since } a - b = a(1 - b/a) = a \div \frac{1}{1 - b/a},$$

$$\log(a - b) = \log a - \log \frac{1}{1 - b/a}.$$

$\log \frac{1}{1 - b/a}$  is called the "subtraction logarithm."

As with addition logarithms, subtraction logarithms are tabulated with  $\log a/b$ , or  $\log a - \log b$ , as argument.

#### Example.

Given  $\log a = 0.57345$  and  $\log b = 0.23147$ , to find  $\log(a - b)$ .

$$\begin{array}{r} \log a = 0.57345 \\ \log b = 0.23147 \\ \hline \end{array}$$

$$\log a - \log b = 0.34198$$

Entering the table of subtraction logarithms with the argument 0.34198, the corresponding subtraction logarithm is found to be 0.26361.

Then :

$$\begin{array}{r} \log a = 0.57345 \\ \text{Subn. log} = 0.26361 \\ \hline \end{array}$$

$$\text{Difference} = 0.30984 = \log(a - b).$$

This result can be confirmed thus :

$$\begin{array}{r} \log a = 0.57345 \quad a = 3.74498 \\ \log b = 0.23147 \quad b = 1.70400 \\ \hline a - b = 2.04098 \\ \log(a - b) = 0.30984 \end{array}$$

Since  $b$  is not greater than  $a$ , the value of  $b/a$  ranges from 1 when  $b = a$ , to 0 when  $b = 0$ . Thus the values of the addition logarithms range from  $\log 2$  to  $\log 1$ , or from 0.301030 to 0. The corresponding arguments,  $\log a - \log b$ , range from 0 to  $\infty$ , but in practice the range is limited. The value of the addition logarithm decreases as the argument increases, and when  $\log a - \log b = 6$  the addition logarithm, to six places of decimals, is 0, so that six place tables need not be taken beyond the argument 6. For subtraction logarithms, the arguments range from 0 to  $\infty$ , while the range of the corresponding subtraction logarithms is from  $\log \infty$  (when  $b = a$ ) to  $\log 1$  (when  $b = 0$ ), or from  $\infty$  to 0.

This inconveniently long range is, however, shortened in practice. In the first place, similarly to addition logarithms, the value of the subtraction logarithm decreases as the argument increases, and when  $\log a - \log b = 6$ , the subtraction logarithm, to six places of decimals, is 0, so that six place tables

do not need to be taken to arguments greater than 6. Furthermore, the argument need not be taken below 0.3, because for lower values of the argument the tables so limited can be used reversed, the argument being looked up in the body of the table, and the corresponding subtraction logarithm being found in the argument column. This can be shown as follows :

For the argument  $\log a - \log b$  the table gives  $\log \frac{1}{1 - b/a}$ , the subtraction logarithm.

Let  $a - b = b'$ , so that  $b = a - b'$ .

Then the argument  $\log a - \log b$  becomes  $\log a - \log(a - b') = \log \frac{a}{a - b'} = \log \frac{1}{1 - b'/a}$ , which is the subtraction logarithm for finding  $\log(a - b')$ .

Also the subtraction logarithm corresponding to  $\log a - \log b$ , i.e.  $\log \frac{1}{1 - b/a} = \log \frac{a}{a - b} = \log a$

$-\log(a - b) = \log a - \log b'$ , which is the argument for finding the subtraction logarithm for obtaining  $\log(a - b')$ . Thus argument and corresponding subtraction logarithm are reversed.

Since between  $b = a$  and  $b = 0$  the range of the argument is from 0 to  $\infty$ , and that of the corresponding subtraction logarithm from  $\infty$  to 0, there is some value for which the argument and subtraction logarithm are equal. At this point we have  $\log a - \log b = \log \frac{1}{1 - b/a}$ , or  $\log a/b = \log a/(a - b)$ .

Therefore at this point  $a/b = a/(a - b)$ ,  $b = a - b$  or  $a = 2b$ . Thus when the argument and subtraction logarithm are equal,  $a = 2b$ , and  $\log a = \log 2 + \log b$ , or  $\log a - \log b = \log 2 = 0.301030$ .

Thus it is only necessary to tabulate the argument from 0.301030 (in practice from 0.3) upwards. The body of the table then contains subtraction logarithms from 0.301030 downwards. For arguments less than 0.3 the argument is sought in the body of the table, and the corresponding subtraction logarithm is found in the normal argument column.

#### Example :

Given  $\log a = 0.57229$  and  $\log b = 0.42959$ , to find  $\log(a - b)$ .

$$\begin{array}{r} \log a = 0.57229 \\ \log b = 0.42959 \\ \hline \end{array}$$

$$\log a - \log b = 0.14270$$

This argument is less than 0.3, so that it must be looked for in the body of the table. 0.14270 in the table corresponds to 0.55276 in the argument column, so that 0.55276 is the subtraction logarithm.

Then :

$$\begin{array}{r} \log a = 0.57229 \\ \text{Subn. log} = 0.55276 \\ \hline \end{array}$$

$$\text{Difference} = 0.01953 = \log(a - b).$$

To confirm this :

$$\begin{array}{r} \log a = 0.57229 \quad a = 3.735 \\ \log b = 0.42959 \quad b = 2.689 \\ \hline \end{array}$$

$$a - b = 1.046$$

$$\log(a - b) = 0.01953.$$

In the examples which have been given it will be seen that the finding of  $\log(a \pm b)$ , when  $\log a$  and  $\log b$  are known, necessitates three references to tables when ordinary logarithms are used, but only one reference when addition or subtraction logarithms are employed. Of course, for a single short computation this saving in time is negligible, but it becomes appreciable with a long computation involving several such steps, or when the number of computations is large. As an example of the saving which is effected, the following calculation of an impedance is carried out, first with ordinary logarithms throughout, and then with addition and subtraction logarithms. References to tables are indicated by asterisks, and it will be seen that in the first method there are 11 such references, whereas there are only 7 in the second.

To evaluate  $\sqrt{R^2 + \left(\omega L - \frac{1}{\omega C}\right)^2}$ , where :

- $\omega = 2\pi f, = 942.477$
- when  $f = 150$  cycles per second
- $R = 36$  ohms
- $L = 0.7$  henry
- $C = 15 \times 10^{-6}$  farads.

*Ordinary Logarithms.*

$\omega$	*log 952.477 = 2.97427
$\omega L$	log $\omega = 2.97427$ *log 0.7 = 1.84510 log $\omega L = 2.81937$ *Antilog = 659.73
$\frac{1}{\omega C}$	log $\omega = 2.97427$ *log $15 \times 10^{-6} = 5.17609$ log $\omega C = 2.15036$ log $1/\omega C = 1.84964$ *Antilog = 70.74
$\left(\omega L - \frac{1}{\omega C}\right)^2$	*log difference = 2.77011 ← Difference = 588.99 $\times 2 = 5.54022$ *Antilog = 346920
$R^2$	*log 36 = 1.55630 $\times 2 = 3.11260$ *Antilog = 1296
$\sqrt{R^2 + \left(\omega L - \frac{1}{\omega C}\right)^2}$	*log sum = 5.54185 ← Sum = 348216 $\div 2 = 2.77093$ *Antilog = 590.1

*Addition and Subtraction Logarithms.*

The procedure is the same as before as far as the finding of  $\log 1/\omega C$ , except that the antilog of  $\log \omega L$  is not found.

The calculation then proceeds as follows :

log $\omega L = 2.81937$	
log $\frac{1}{\omega C} = 1.84964$	
log $\omega L - \log \frac{1}{\omega C} = 0.96973$	
*Subtraction log = 0.04925	
log $\omega L - \text{subn. log} = 2.77012 = \log \left(\omega L - \frac{1}{\omega C}\right)$	
$\times 2 = 5.54024 = \log \left(\omega L - \frac{1}{\omega C}\right)^2$ (a)	
*log 36 = 1.55630	
$\times 2 = 3.11260 = \log R^2$ . . . . . (b)	
(a) - (b) = 2.42764	
*Addition log = 0.00162	
(a) + addn. log = 5.54186 = log	
$\left(R^2 + \left(\omega L - \frac{1}{\omega C}\right)^2\right)$	
$\div 2 = 2.77093 = \log$	
$\sqrt{R^2 + \left(\omega L - \frac{1}{\omega C}\right)^2}$	
*Antilog = 590.1 = $\sqrt{R^2 + \left(\omega L - \frac{1}{\omega C}\right)^2}$ .	

Although addition and subtraction logarithms seem to be little known in this country outside the ranks of professional computers, they are by no means new. They were first proposed by Z. Leonelli, in his "Théorie des logarithmes additionnels et déductifs," published in 1803 at Bordeaux. Leonelli calculated a table to 14 places, but only the specimen portion of this table which was included in his book as an illustration was ever printed.

During the early years of the nineteenth century addition and subtraction logarithms were made widely known by Gauss, and because of this they are frequently known as Gaussian logarithms. The first full table actually published was due to Gauss. It was to five decimal places, and was printed in 1812 in Zach's "Monatliche Korrespondenz."

Until recently nearly all the tables of these functions have been published either in Germany or France. This year, however, a second edition of Cohn's "Tables of addition and subtraction logarithms to six decimals," originally published in 1909 at Leipzig, has been brought out by Scientific Computing Service, Ltd., 23 Bedford Square, W.C.1. This edition contains a preface in English giving full explanations of the use of the tables, as well as the original preface in German.

In addition to this set of tables there are four-figure tables of addition and subtraction logarithms, with full explanations, in the collection of "Standard Four-figure Mathematical Tables," by Milne-Thomson and Comrie, published in 1931 by Macmillan & Co.

# The Operation and Utilisation of Echo-Suppressors

R. E. JONES, M.Sc., A.M.I.E.E.

U.D.C. 621.395.648.1

In this article the main types of echo-suppressor are discussed, together with a consideration of the factors that affect their operation and utilisation.

## Introduction.

**A**N echo-suppressor, as the name implies, is a device intended to eliminate undesired effects due to reflected currents in a telephone circuit. These reflected or echo currents, which are returned to both talker and listener, are not of importance when they are heard substantially at the same time as the speech signals, but become increasingly important as the echo delay time becomes greater. The order of echo delay times that are encountered in practice can be estimated from a knowledge that, whereas on non-loaded or aerial line systems velocities of transmission of 150-180 miles per millisecond are obtained, on coil-loaded lines the velocity falls to values of 20 and even 10 miles per millisecond. Echoes having delays of up to 20 milliseconds are difficult to detect as separate sounds, and it will be seen that these correspond to lengths of echo paths varying from 3,600 to 200 miles for the types of circuit referred to, which, for simple 4-wire circuits, correspond to route lengths of 1,800 to 100 miles. It is, therefore, evident that, particularly on low velocity coil-loaded underground cable circuits, echo delay times considerably greater than 20 milliseconds will quite often occur. The annoyance value of echo is determined not only by the delay but also by the loss in the echo path and these two factors combine to produce the total impairment. The effect of echo is different for talker and listener. For the former, the main effect, to those familiar with the phenomenon, is that it interferes with the smooth flow of conversation; whereas for those to whom it is strange, it appears as the effort of another talker endeavouring to interrupt. For the listener, however, echo operates as a direct reduction of intelligibility. In the study of impairment due to echo, it is necessary, therefore, to consider the two conditions separately. It will be readily understood, however, that although the delays in listener and talker echo paths are equal, the loss is greater in the listener paths and hence, almost always, talker echo is found to be the limiting condition.

Echo-suppressors are operated by the speech signals themselves and when operated introduce sufficient loss into the return direction of transmission to reduce the volume of the echo to negligible or, at least, tolerable proportions. It follows that the point in the circuit at which they are introduced must be where the directions of transmission are separated, *i.e.*, where the construction is 4-wire. Where echo-suppressors are installed on circuits which are normally of 2-wire construction, the point at which the echo-suppressor is introduced must be equipped with 2-wire/4-wire termination sets. By far the big majority of echo-suppressors are, however, installed on audio circuits which are of 4-wire construction, in coil-loaded underground cables. Carrier

systems which operate on non-loaded underground cables will not normally require the installation of echo-suppressors by virtue of the small delay times that occur.

Various types of echo suppressor have been developed and this article describes the main types and the factors governing their employment.

## Types of Echo Suppressor.

Echo-suppressors have been classified under two main groups which are known as units having (a) discontinuous action and (b) continuous action. The former class comprises those in which the suppression loss is obtained by the operation of a mechanical switch so that the suppression loss characteristic passes immediately from the quiescent to the fully operated condition and, in a similar manner, during the release operation, the loss, when it is removed, is removed suddenly and the circuit restored to its quiescent condition.

The second class, of continuous acting units, comprises those in which the transition from the quiescent state to the operated state is more or less gradual, depending on the design. Where the steepness of the characteristic of the continuous acting type approaches that of the mechanical switch, it is justifiable and common practice to refer to such a device as an electrical switch.

Up to the present time, echo-suppressors utilised in the U.S.A. have been of the discontinuous type and those utilised in Europe have been of the continuous type.

## Methods of Obtaining Suppression.

There are three main methods of obtaining suppression loss which have been utilised in echo-suppressors. They are as follows:

- (1) Relay operation.
- (2) Grid-jamming.
- (3) Rectifier attenuation networks.

*Relay Operation.*—This method has been utilised in America. The echo-suppressor consists essentially of an amplifier-rectifier having controllable time characteristics, in the output circuit of which is a relay which short-circuits the return direction of transmission. This echo-suppressor is described in a paper by Clark and Mathes<sup>1</sup>.

*Grid-jamming.*—This method was developed by Robinson and Chamney<sup>2</sup>, of the British Post Office, and has been used in a number of European countries. The echo-suppressor consists essentially of an amplifier-rectifier having controllable time characteristics, the rectified voltage output of which is applied in a negative sense in the grid-cathode circuit of an amplifying valve in the return direction of trans-

<sup>1</sup> *A.J.E.E.J.*, June, 1925.

<sup>2</sup> British Patent 225603.

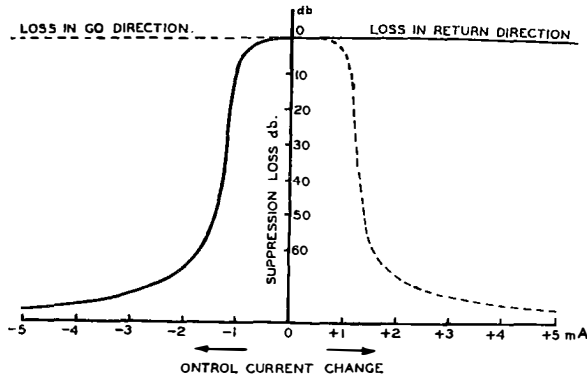

FIG. 1.—LOSS CHARACTERISTIC OF RECTIFIER ATTENUATION TYPE ECHO-SUPPRESSOR.

mission, in such a manner as to nullify its amplification. Hence the derivation of the term "grid-jamming" for this type of operation. Approximately 600 echo-suppressors of this type have been installed in Gt. Britain.

There is no reason why this method, on theoretical grounds, should not be entirely satisfactory. There are two practical difficulties, however, which influence its utilisation. These are, first, that the design of the valve which is to be grid-jammed is more complicated than it would otherwise be, to ensure that the application of a reasonable negative potential to the grid does effectively nullify the amplification of the valve, and, secondly, in order to prevent undesired surge signals due to the collapse of the anode current, it is desirable that the suppressed amplifier should be of balanced (push-pull) construction, with consequent complication to the amplifier design.

This method of grid-jamming has, however, been used quite extensively in Europe up to the introduction of rectifier-attenuation networks, which is the third and generally adopted method for all new designs.

**Rectifier Attenuation Networks.**—The properties of dry plate metal rectifier elements have been known for many years and in 1930 the general problem of their utilisation for the construction of loss networks was actively investigated.<sup>3</sup> In earlier articles in this JOURNAL, detailed descriptions have been given of the form of variable attenuation network used in the Post Office No. 3 and No. 5 type echo-suppressors.<sup>4</sup> The networks consist essentially of non-linear resistance elements (dry plate rectifier elements) inserted in series and shunt arrangements in the transmission line, the impedance and hence the transmission loss of such networks being determined by a control current. The type of loss characteristic obtained in terms of the control current is shown diagrammatically in Fig. 1, although it will be appreciated that the actual shape can be varied, depending on the network arrangement employed.

Metal-rectifier attenuation networks have very considerable advantages from the standpoint of size, cost and reliability. Their performance as a switch can be made to approach very nearly that of a mechanical switch, without the disadvantage of the

maintenance adjustments that appertain to the latter. The suppression loss obtained can be arranged to be amply sufficient for all normal purposes. They are substantially free from contact resistance troubles.

#### Prevention of False Operation by Pre-Echo.

The echo-suppressor in its simplest form consists of two independent half units S1 and S2 at positions ab and cd in a telephone circuit AB as shown in Fig. 2a. Positions ab and cd will be, in general, intermediate points in the circuit and it will be observed that they are arranged with regard to the direction of transmission so that a point of suppression occurs before the point at which an input is derived. If this were not so, the echo signals themselves would be capable of causing false operation.

Such an arrangement is still liable to false operation (by signals transmitted from A to B) due to echo signals that pass the point b before the operation of S1 is complete. This pre-echo signal, as it is termed, may partially or fully operate S2 leading to partial or full mutilation of the A-B transmission.

This is normally prevented by maintaining the effective sensitivities of S1 and S2 approximately equal and by arranging that the transmission time aBb (or cAd) is equal to or greater than the operating

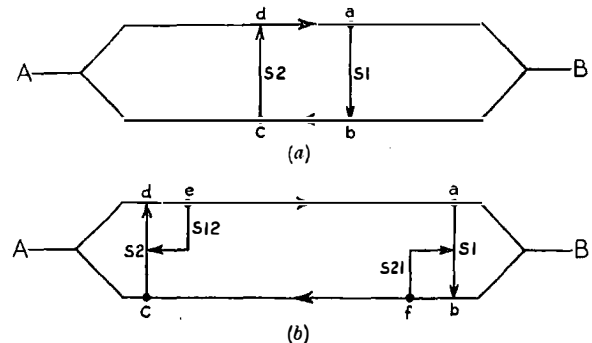

FIG. 2.—PRINCIPLE OF OPERATION.

time of S1 (or S2). The latter requirement cannot be fulfilled when the echo-suppressor is required to be installed at the terminal station. It can be approached by making the operating time of S1 and S2 very short, so that an inappreciable amount of pre-echo exists, either as a false-operating signal or as an annoyance. This time has been determined at 1.5 milliseconds for peak signals. It follows, however, that for continuous-acting types, considerable operating times are encountered near the operating limit and this fact, coupled with possible differences in effective sensitivity, may still lead to a degree of false operation. An investigation into this effect is described in an article by Strecker.<sup>5</sup>

Two methods have been developed to eliminate false operation. They are normally referred to as "suppressor-suppressor action" and "differential operation." The former is possibly a more natural line of action and comprises the disablement of the unwanted suppressor by an auxiliary suppressor-suppressor. It has an advantage regarding lock-out to which reference will be made later. The latter

<sup>3</sup> French Patent 708559.

<sup>4</sup> P.O.E.E.J., Vol. 28, p. 27, and Vol. 30, p. 186.

<sup>5</sup> T.F.T., August, 1937.



method is novel and is due to L. E. Ryall, of the British Post Office.

*Suppressor-Suppressor Action.*—The operation of this method will be described with reference to Fig. 2b, in which it will be observed that the suppressor units are shown at terminal stations, the auxiliary suppressors being marked S12 and S21. A signal transmitted from A to B operates, in turn, the suppressor-suppressor S12 and then the echo-suppressor S1. The latter must be fast-operating, however, to guard against S21 delaying or preventing its operation. By virtue of the transmission time in the path eBc, the operating time of S12 (and S21) can be greater than that of S1 (and S2). The real purpose of suppressor-suppressor action is considered to lie, however, in the prevention of lock-out rather than in the prevention of false operation, on account of the reaction of S21 on S1 referred to above. The necessity of guarding against lock-out will be considered in due course. The British Post Office has not so far adopted the use of the suppressor-suppressor principle.

*Differential Operation.*—This method has been adopted by the Post Office for all recent developments in echo-suppressors and like equipments. The essential feature lies in the interlock arrangement whereby when one direction is operated to become of high loss, the other direction is biased back by an equal amount to remain of no loss, so that it is not possible for both directions to be of high loss at the same time. The principle of differential operation is, of course, independent of the method used for obtaining suppression loss, but will be illustrated in its application in conjunction with rectifier attenuation networks. In Fig. 1 is shown a typical loss characteristic of the type of network employed in terms of the control current which determines this loss. Fig. 3 shows how this control current is obtained. The two networks N1 and N2 are, in respect to the control current, arranged in a bridge formation, so that each network receives a quiescent current of 1.2 mA for example. The out-of-balance in this condition is zero, which fixes the point shown as zero in Fig. 1. In this condition both networks are of no loss. It is apparent that if the impedance of one valve in the bridge arrangement is changed, by the application of rectified speech voltages in a positive manner in the grid-cathode circuit for instance, an out-of-balance current will flow across the bridge in such a manner as to cause one network to remain of low loss, whereas the other

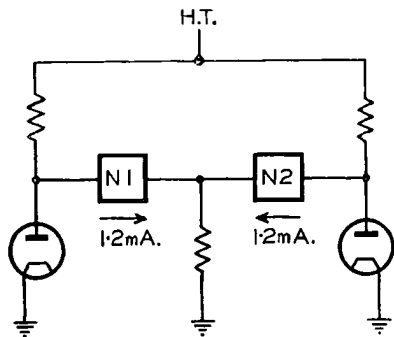

FIG. 3.—DERIVATION OF THE CONTROL CURRENT.

network, on account of the reversal of the control current, will become of high loss. It is equally apparent that it is not possible for both networks to be of high loss simultaneously. In this manner, by maintaining the operating characteristics of the two halves approximately equal, a complete safeguard against false operation is obtained. Other advantages accrue from the use of differential operation. A safeguard against noise operation is obtained in the following manner. If, for example, there is present at both inputs a small amount of noise signals, then both bridge valves will tend to be actuated in a like manner with the result that the bridge will tend to remain balanced; whereas with other types, partial operation of the two halves independently would have resulted. Or again, if there should be weak speech in one direction which is not strong enough to operate the echo-suppressor fully, it will tend to prevent any noise in the reverse direction from falsely operating the suppressor, since the noise voltage will now have to overcome the bias set up by the weak speech signals. The differential arrangement therefore enables speech signals to hold the suppressor more easily against noise signals present in the opposite direction.

#### *False Operation of Terminal Echo-Suppressors.*

An echo-suppressor located at a terminal of a 4-wire circuit is liable to a particular form of false operation. This is best illustrated by Fig. 4. This shows a 4-wire circuit terminated at A having a transmit direction

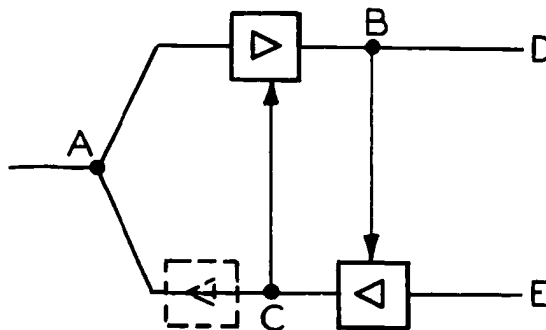

FIG. 4.—TERMINAL ECHO-SUPPRESSORS SUBJECT TO FALSE OPERATION.

AD and a receive direction EA. A full double-acting echo-suppressor is derived at B and C. A signal applied at the 2-wire line at A will be at a level of  $+n_1$  db. at B and at a level of  $-n_2$  at C. In this country these values are generally  $+10$  db. and  $-10$  db. respectively. Since the local sensitivities of the echo-suppressor at B and C are equal, it follows that there is a bias of  $(n_1 + n_2)$  db. in favour of operation in the correct direction, which in the example quoted, is a bias of 20 db. It will be apparent, however, that this bias will no longer be obtained should there be suppression loss present in the path AB. This occurs when the signal applied at A follows immediately after or simultaneously with a signal received from E. Should the suppression loss introduced in this way exceed 20 db., a condition favourable to false operation would be obtained. With speech signals this effect has not been found

to be serious, since the discontinuous envelope of speech sounds always enables the echo-suppressor to take control in the right direction, with substantially no clipping. Experience has only been obtained with continuous type echo-suppressors, however, and it is probable that a considerably more serious degree of false operation would be obtained with relay type units, unless the suppression loss were limited to an adequate but not excessive amount. With continuous tone signals this effect is naturally much more serious, and hence it becomes necessary where echo-suppressors are used in conjunction with systems such as the 2 V.F. signalling scheme, to ensure that such false operation cannot occur.

The most obvious method of preventing this type of false operation is to insert a buffer amplifier between points A and C. It is seldom found possible to use the gain of this amplifier usefully, and such provision is accordingly uneconomic.

Adequate safeguard against false-operation can, however, be obtained by the use of a hybrid coil instead of an amplifier in the manner shown in Fig. 5. This scheme is cheaper both on first cost and annual charges.

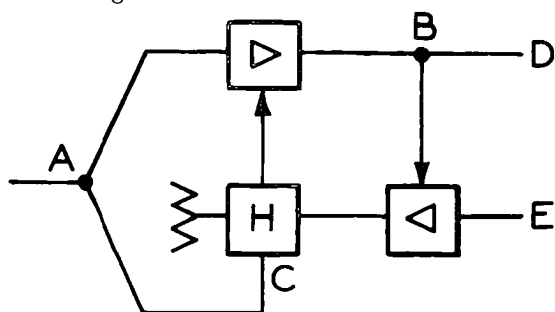

FIG. 5.—USE OF HYBRID COIL AS SAFEGUARD AGAINST FALSE OPERATION.

Another method, which depends on the use of signals in phase opposition, has already been described in this Journal.<sup>6</sup>

Other methods have been investigated but have proved to be less satisfactory than those already mentioned

#### *Factors Affecting the Effective Speech Sensitivity of Echo-Suppressors.*

The four main factors that determine the effective speech sensitivity of echo-suppressors are (a) the tone sensitivity setting; (b) the shape of the sensitivity-frequency characteristic; (c) the operating time-input level characteristic and the restoring time-input level characteristic.

#### *Sensitivity and Sensitivity-Frequency Characteristic.*

A certain amount of tuning of the sensitivity-frequency characteristic is unavoidable on account of the frequency spectrum of speech compared to that of noise, in order to obtain the maximum advantage to speech. This tuning differs in different territories according to the types of noise encountered. In this country, the limiting noise has been established to be due to switchroom noise picked up in the operator's

<sup>6</sup> P.O.E.E.J., Vol. 30, p. 186

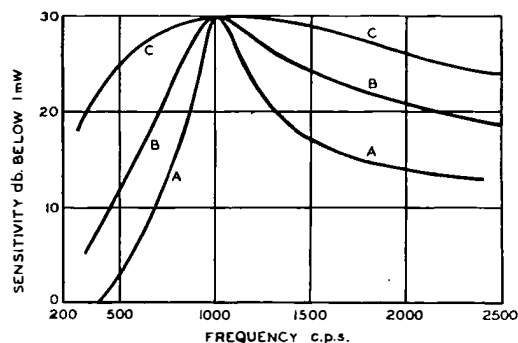

FIG. 6.—SENSITIVITY-FREQUENCY CHARACTERISTIC.

headset and has a spectrum like that of speech, due to the weighting of the transmitter characteristic. This ignores certain special cases such as radio channel noise regarding which special steps will need to be taken. The shape of the sensitivity-frequency characteristic employed in this country is shown in curve C of Fig. 6 compared to that of types used elsewhere. The effect of this shaping on the effective speech sensitivity will be described later. Having determined the shaping to be employed, the sensitivity level can be fixed to give a margin of safety against noise operation. The value employed in this country is such that a level of -30 db. at 800 c.p.s. at a zero level point gives rise to a suppression loss of 30 db. This is in substantial agreement with the recommendation of the C.C.I.F., which states that this level, for a suppression loss of 6 db., should lie between -22 and -31 db.

The shaping of the sensitivity-frequency characteristic recommended by the C.C.I.F. has been made somewhat indefinite in order to accommodate the conflicting requirements of various administrations. The recommendation states that the frequency of maximum sensitivity should lie between 700 and 1,200 c.p.s., that the effective width of the frequency band at 1.0 neper from maximum sensitivity should be at least 500 c.p.s., and at 1.5 nepers should be at least 1,000 c.p.s.; together with a general recommendation that the curvature of the characteristic should be less at high than at low frequencies.

*Operating and Restoring Time-Input Level Characteristics.*—In order to obtain a high effective speech sensitivity, it is desirable that the operating time should be small and constant over as wide a portion of the working range of input signals as possible. On the other hand, the restoring time should be maintained reasonably long in order to bridge the weak syllables in speech sounds. One limit to the length of the restoring time is fixed by the possibility of initial clipping of responding speech signals, transmitted along the return path. Tests carried out in Gt. Britain with terminal echo-suppressors, where this effect would be most pronounced, have shown that inappreciable initial clipping occurs with restoring times up to 250 milliseconds. On the other hand, unnecessary reduction of restoring time will detract from speech sensitivity. Close adjustment of restoring time is never desirable. The restoring time should also be reasonably constant over as wide a range of working

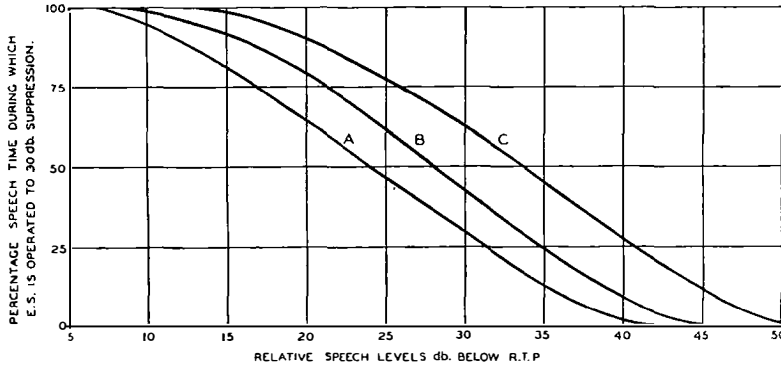

FIG. 7.—EFFECT OF SENSITIVITY-FREQUENCY CHARACTERISTIC.

input levels as possible. This independence of the time factors on input level is normally obtained by a saturation device, which, for the later types of suppressor used in this country, is arranged to be operative for signals 20 db. below peak loading. The C.C.I.F. has made the following recommendations regarding the time characteristic of echo-suppressors :

Operating time : at the frequency of maximum sensitivity

Input Level	Operating Time
(a) 20 db. above normal sensitivity.	1 to 2.5 milliseconds.
(b) 6 db. above normal sensitivity.	less than 15 milliseconds.

Restoring time : at the frequency of maximum sensitivity

Input Level	Restoring Time
(a) 20 db. above normal sensitivity.	Equal to 2.25 times the time between the echo-suppressor and the end of the circuit plus 50 milliseconds.
(b) 6 db. above normal sensitivity.	At least one-quarter the value determined above.

It is further recommended that the restoring time (a) should be rounded off to one of three values 50, 150 or 250 milliseconds and should never exceed 250 milliseconds.

*Measurements of Effective Speech Sensitivity.*—Tests are being carried out to assess the importance of the various factors that determine the effective speech sensitivity of an echo-suppressor by measuring the percentage of the speaking time during which the suppressor under test is operated to a loss of 30 db. The percentage is determined by a comparison of the times during which the working suppressor and another of considerably greater sensitivity are operated from

regulated speech signals. Adequate precautions are taken against noise operation.

*The Effect of the Sensitivity-Frequency Characteristic.*—In Fig. 7 are shown three curves A, B and C, corresponding to the response characteristics given in Fig. 6. Curve C applies to the modern suppressors used in this country (Nos. 3, 4 and 5) and curves A and B to other types in use.

It will be observed that at 50 per cent. operation, the change of effective speech sensitivity can be as much as 10db. This fact emphasises the undesirability of sharp tuning of the suppressor characteristic.

*The Effect of Operating and Restoring Time.*—Fig. 8 shows two curves relating to existing types of echo-suppressor in use in this country. The No. 2 suppressor is of the old grid-jamming type having a frequency characteristic approximately that of curve B in Fig. 6, whereas the No. 5 is of the attenuation network type having a frequency characteristic approximately that of curve C in Fig. 6. The operating and restoring times are shown in the table on Fig. 8. Although this investigation is still in hand and the actual numerical values are subject to alteration, there is evidence that, although the increased restoring time tends to offset the loss of sensitivity due to increased operating time and sharper tuning, the No. 2 type is in the order of 9 db. less sensitive than the No. 5 for equal tone sensitivities. Since half this amount is due to the sharper tuning, the remainder is on account of the time characteristic.

*Lock-out.*—In general, on circuits equipped with two or more echo-suppressors, a condition of lock-out can arise due to the suppressors being operated in such a manner as to prevent either subscriber from hearing the other.

The true extent to which lock-out could adversely affect a built-up connection had not been investigated until recently,<sup>7</sup> with the result that the danger from

<sup>7</sup> E.F.D., October, 1934. and B.S.T.J., April, 1938.

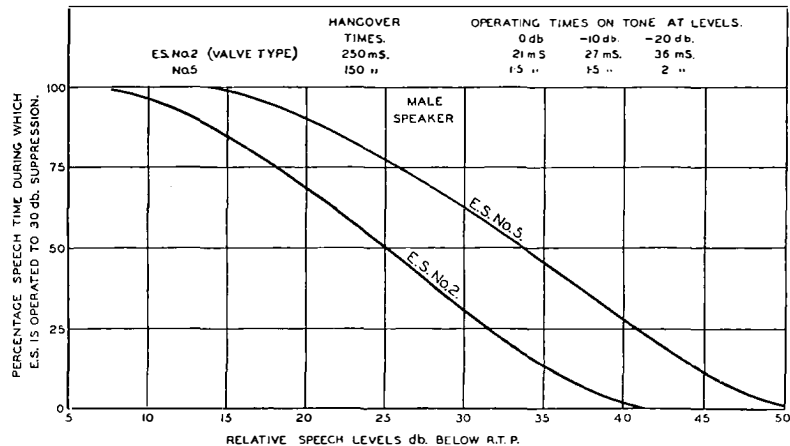

FIG. 8.—SPEECH SENSITIVITIES OF ECHO SUPPRESSORS NOS. 2 AND 5.

this form of false operation has in the past tended to be over-estimated. It is, for instance, considered to have influenced the layout of suppressors used in certain countries in the manner shown in Fig. 2b, but without suppressor-suppressor action, in order that intermediate and unwanted half suppressors in a built-up connection could be switched out of circuit. This was advocated as recently as 1934.<sup>8</sup> It is understood, however, that it is no longer intended to do this in those territories where such layouts apply. It has also led to the development of suppressor-suppressor action as described earlier which reduces but does not eliminate the chance of lock-out occurring.

Since no precautions had been taken in Gt. Britain against the danger of lock-out on built-up connections, tests were carried out on specially set-up connections up to a maximum transmission time between echo-suppressors of 300 milliseconds. The number and durations of the lock-out periods were measured, and specially trained observers were employed to record speech repetitions, those coinciding with a state of lock-out being recorded

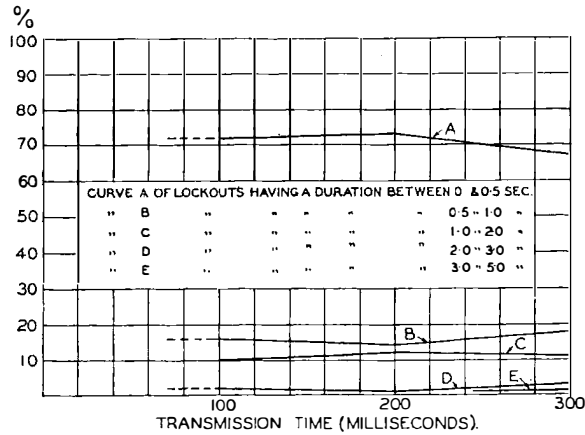

FIG. 9.—PERCENTAGE OF LOCKOUTS ACCORDING TO DURATION.

separately. For convenience in analysis, lock-out periods were grouped in steps of 0 to 0.5 seconds, 0.5 to 1 second, and then in 1 second steps.

From the percentage of lock-outs of various durations in terms of the transmission time between the echo-suppressors given in Fig. 9, two facts are outstanding. First, the distribution is independent of the transmission time between the echo-suppressors and, secondly, a very large proportion of the total lock-outs which occur are of very short duration and are ineffective in interfering with the conversation. Since, as will be seen later in the correlation of lock-out durations and repetition rate, only a proportion of lock-outs greater than 1 second duration need be taken into account, it follows that between 80 and 90 per cent. of the lock-outs that occur in practice are of negligible impairment value.

In Fig. 10 is shown the number of lock-outs of various durations per 100 seconds of conversation time in terms of the transmission time between the echo-suppressors. These figures should be studied in

<sup>8</sup> VOE—*Fachbesichte*, 1934.

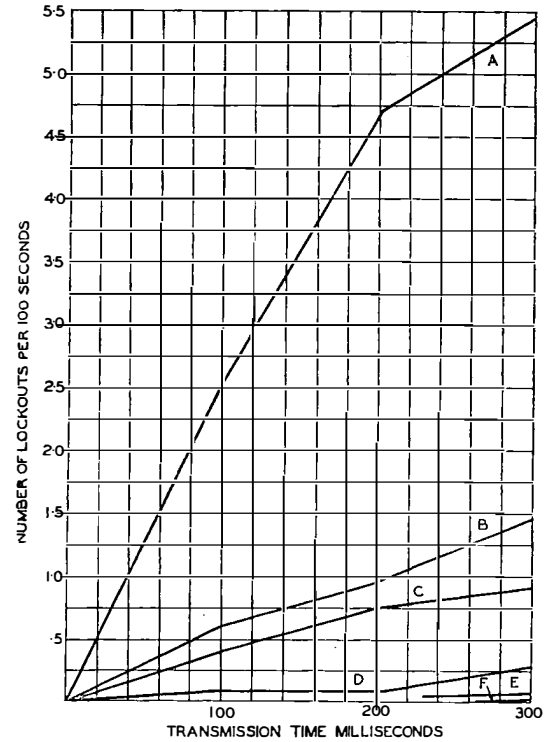

FIG. 10.—NUMBER OF LOCKOUTS PER 100 SECONDS HAVING A DURATION OF

- A. Between 0 and 0.5 secs. D. Between 2.0 and 3.0 secs.  
 B. " 0.5 " 1.0 " E. " 3.0 " 4.0 "  
 C. " 1.0 " 2.0 " F. " 4.0 " 5.0 "

conjunction with Fig. 11, which shows in curve A the total repetition rate for the various circuit conditions, and in curve B the rate determined by experiment to be due to lock-out.

The high repetition rate values are mostly due to the long transmission times between talkers and the transient distortion which, at the high and low frequencies in the speech band, exceeded 50 milliseconds for the longest connections.

By inspection of the number of repetitions and the number of lock-outs of various durations occurring in 100 seconds can be deduced the complete unimportance of short period lock-outs.

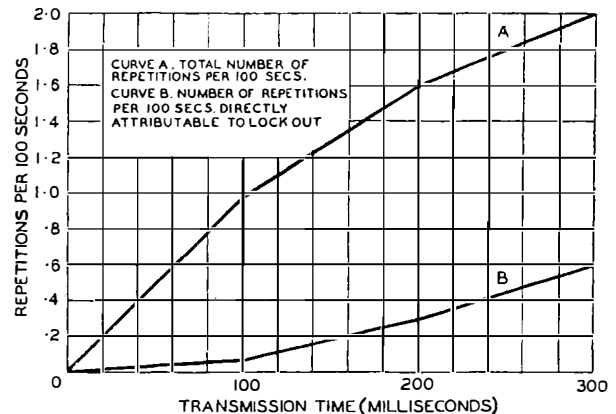

FIG. 11.—NUMBER OF REPETITIONS PER 100 SECONDS.

To assess the importance of lock-out, at 100, 200 and 300 milliseconds transmission time, the transmission index (T.I.) both with and without lock-out is shown in the following table. The index is a factor given by the expression  $T.I. = 50 (1 + \log r)$  where  $r$  is the repetition rate.

Transmission Time mS.	Transmission Index		
	Total	Without Lock-out	Difference
300	65	57	8
200	60	55	5
100	50	48	2

Present experience in connection with effective transmission has shown that the values of T.I. can be regarded as a measure of the effective transmission and the differences can be regarded as impairment values in decibels. It is noteworthy that the impairment increases nearly proportionally with transmission time. This means that there is no value of transmission time at which the impairment increases rapidly: if this were so, it would give a means of fixing the maximum permissible time between echo-suppressors. On the other hand, it is evident that the effect exists at all transmission times and it only remains to assess the relative value of the impairment. As a basis of comparison, the impairment due to the average room noise measured at telephone stations in London is estimated to be 12 db. and at 30 per cent. of stations values greater than 20 db. occur for appreciable lengths of time.

As a result of this analysis it can be stated quite definitely that lock-out is not an important factor in degrading telephone transmission; that the impairments obtained are quite negligible where the transmission time between echo-suppressors does not exceed 150 milliseconds and that for times in excess of this, the impairment increases in approximately direct proportion to the transmission time and only reaches appreciable dimensions where the time of transmission approaches the present limit for commercial transmission, namely, 250 milliseconds.

Tests carried out in Germany and in the U.S.A. confirm the conclusion regarding the relative unimportance of lock-out. The German conclusion is, substantially, that lock-out is not a determining factor regarding the maximum permissible transmission time between echo-suppressors, the impairment being less than that due to the transmission time itself. The American attitude is more cautious and, although the unimportance of lock-out is established, the provisional limit of 100 milliseconds maximum time spacing between echo-suppressors is maintained.

#### Utilisation of Echo-Suppressors.

Echo-suppressors are provided on all 4-wire circuits which, on account of the delay and audibility of echo currents, are capable of causing annoyance to the subscribers. In order to estimate whether

or not an echo-suppressor should be fitted for this purpose, experimental investigations have been carried out by all the major administrations to determine the maximum tolerable amount of echo at various delay times. Chiefly on account of the limitation of echo-suppressor sensitivity, which is due to the possibility of noise operation, voice operation is normally incomplete and it is necessary, therefore, to determine in the same way the maximum tolerable amount of residual and pre-echo. This work has recently been summarised and the results of the various administrations co-ordinated by the C.C.I.F. The standards adopted and the manner in which they are utilised in echo calculations have been fully described in this JOURNAL by A. C. Timmis.<sup>9</sup>

The work carried out in the U.S.A. regarding the determination of experimental curves relating to echo loss and delay has been described by Abraham,<sup>10</sup>

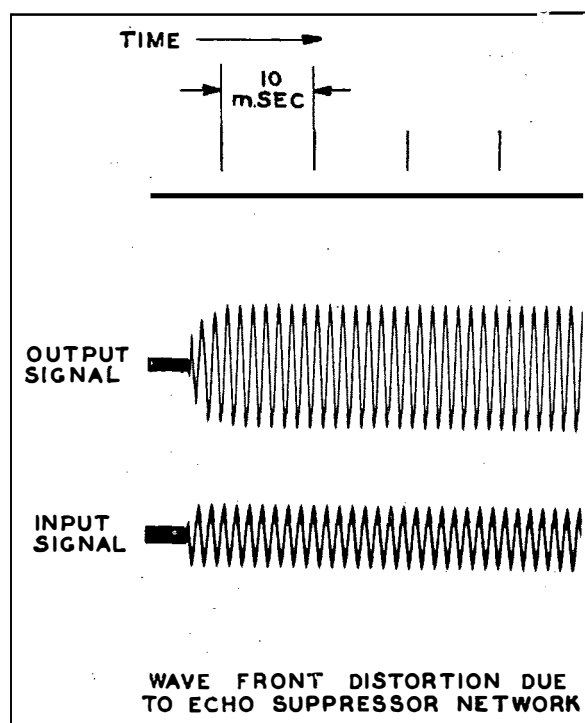

FIG. 12.—OSCILLOGRAM ILLUSTRATING WAVE FRONT DISTORTION.

and that carried out in Germany has been described by Strecker.<sup>11</sup>

In the transmission of speech signals, a relatively large amount of transient distortion is permissible. Advantage of this fact was taken in the design of certain echo-suppressors employing metal-rectifier attenuation networks, to simplify and cheapen the design. Small control currents have been used when the networks rest in the quiescent condition, so that correspondingly small charges are necessary to effect a certain degree of suppression. The networks in the quiescent condition have, accordingly, a small power-handling capacity, although they do, by

<sup>9</sup> P.O.E.E.J., Vol. 31, p. 16.

<sup>10</sup> B.S.T.J., October, 1933.

<sup>11</sup> Loc. cit.

design, have adequate capacity when fully operated. This leads to a form of transient distortion which is commonly referred to as "wave-front distortion" in its reaction on continuous tone signalling systems. A typical oscillogram (Fig. 12) shows the nature of the effect. Although the amounts of distortion obtained are not serious, it will be necessary on all new types of echo-suppressor to take special account of the requirements of the new signalling systems, since these are in many respects more severe than those for speech.

Echo-suppressors have also been used in Gt. Britain on 4-wire circuits in the zero loss trunk network, to guard against interference that might otherwise arise due to uncontrolled singing, occasioned by both ends of the trunk line being left disconnected or by a fault condition. An alternative arrangement would be to employ modified echo-suppressors having, in addition to the loss which is introduced into the echo path, a stabilising loss which is normally in either one or both of the forward transmission paths and which is removed from circuit by the action of the forward transmitted signals. Such a device is properly referred to as a singing-suppressor. The amount of loss in the forward transmission paths in the quiescent condition can be made as small or as large as desired. In most singing-suppressors at present in use, this loss is quite large and it is necessary to ensure that the speech operation does effectively remove the loss. To enable this to be done special measures are taken which cannot be economically applied to echo-suppressors for trunk line operation.

It will be apparent that the amount of the stabilising loss provided by the suppressor will serve not only as a preventive against singing, but in the non-operated or partially operated condition during the passage of weak speech signals will reduce the echo level and thus improve the performance of the circuit from the echo standpoint. It is possible, therefore, to design a singing and echo-suppressor having a small loss in the forward transmission paths which, under present sensitivity conditions, will not appreciably degrade the forward transmission due to partial or non-operation under certain speech conditions but will, under such conditions, improve the performance of the circuit from the echo standpoint.

Tests have shown that a modification of this type could be fairly readily applied to the No. 5 echo-suppressor. Experimental singing-suppressors have

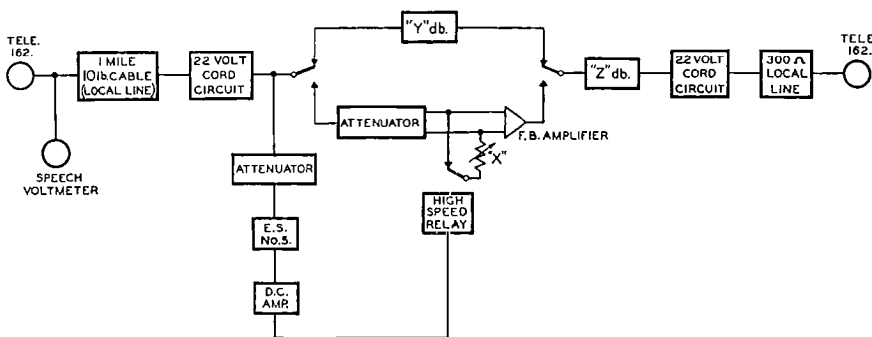

FIG. 13.—SCHEMATIC OF CIRCUIT FOR DETERMINING IMPAIRMENT DUE TO PARTIAL OPERATION OF SINGING-SUPPRESSORS.

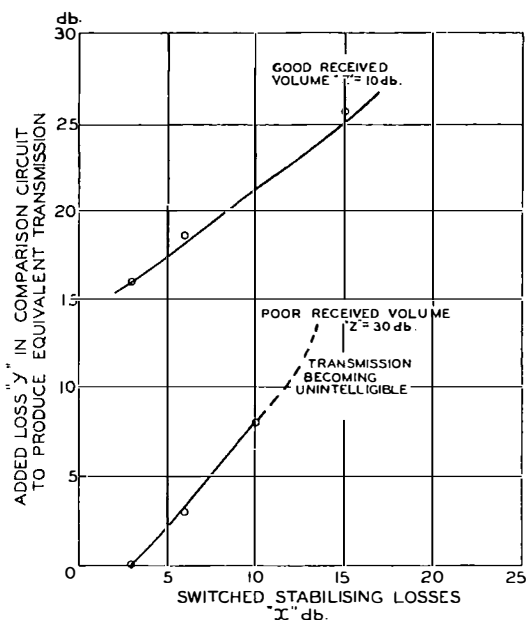

FIG. 14.—IMPAIRMENT OF TRANSMISSION DUE TO PARTIAL SPEECH OPERATION OF A SINGING-SUPPRESSOR.

also been constructed and submitted to field trials on international circuits.

#### Impairment Due to Partial Operation of Singing-Suppressors.

A circuit was set up containing a singing-suppressor (of fast operating time) which, on operation, removed a stabilising loss  $x$  from the transmission path. The layout of the apparatus is shown in Fig. 13. The observers were asked to listen to passages of simple text over this circuit and indicate whether or not they preferred it to an alternative straight circuit containing an attenuation  $y$  db. By manual adjustment, the suppressor was controlled so that the stabilising loss was continually being switched in and out. The transmission elements common to both systems are indicated in the diagram. Four values of stabilising loss were investigated, namely, 3, 6, 10 and 15 db. The tests were carried out with a number of preset values of  $y$  applied in random sequence. For each value, the percentage of observers which preferred  $y$  was recorded and the value at 50 per cent. was taken to be the impairment due to the switching of  $x$ .

In Fig. 14 are shown two curves of impairment for a range of stabilising pads up to 15 db. for two received volumes corresponding to good and poor transmissions.

It will be observed that much larger values of  $y$  are required to express the impairment when the received volume is loud than when it is faint. This is to be expected since added attenuation does not degrade the transmission provided there is sufficient received volume for comfortable listening. The 16 db.

impairment corresponding to a 3 db. stabilising loss for the curve at good volume marks the point at which further loss begins to degrade the standard of transmission, and the zero value of  $y$  for the 3 db. loss at faint volume indicates that a stabilising loss of less than this value is difficult to detect under any reasonable circumstances. It is possible, therefore, to deduce the following impairment values :—

Stabilising Pad db.	Impairment	
	Loud Call	Faint Call
3	0	0
6	2.5	3.0
10	5.5	8
15	9	—

For larger values of stabilising pad, the possible impairment values under partial switching conditions are such as to render the call unintelligible. Partial operation of an echo-suppressor is often caused by loss in the local line and since this also attenuates the amount of echo, the effects are compensating. In fact, it is generally agreed that additional loss in the local line always reacts favourably in respect of echo annoyance. If, however, with a singing-suppressor, in order not to introduce the above impairment into the forward

transmission path, it becomes necessary to rely on operation for, say, 90 per cent. of the speech time, present indications are that, for a zero level sensitivity of  $-30$  db., between 30 and 40 per cent. of calls will be degraded.

It is the present intention of the British Post Office, therefore, that, where echo-suppressors having stability margin are employed on trunk lines and have a zero level sensitivity of  $-30$  db., the stabilising pad shall have a value not exceeding 5 db.

#### Conclusion.

It has been the intention to set out, in this article, the present state of the art regarding the development and operation of echo-suppressors. The factors which influence their proper functioning by the transmitted signals have been described. No special mention has been made regarding any special requirements for such systems as 2 V.F. signalling and dialling or V.F. telegraph (TELEX), since these have actually been covered in the general problem of proper operation. It should be stated, however, that systems such as these, which are more critical regarding the operation of echo-suppressors, would almost certainly be adversely affected by the introduction of stabilising echo-suppressors (singing-suppressors) due to the initial clipping distortion that would be encountered.

### TELEGRAPH AND TELEPHONE PLANT IN THE UNITED KINGDOM WIRE MILEAGES. THE PROPERTY OF, AND MAINTAINED BY THE POST OFFICE IN EACH REGION AND ENGINEERING DISTRICT AS AT 30th SEPTEMBER, 1939.

OVERHEAD WIRE MILEAGES			REGION OR DISTRICT	UNDERGROUND WIRE MILEAGES		
Trunks and Telegraphs	Junctions	Subscribers*		Trunks and Telegraphs §	Junctions †	Subscribers ‡
826	1,456	63,508	London Region	451,431	1,282,868	3,354,681
2,160	9,555	72,695	South-Eastern	215,955	53,082	397,605
9,280	24,385	142,038	South-Western	246,816	44,720	389,696
9,116	19,934	116,298	Eastern	342,072	61,786	279,776
9,041	17,862	110,522	North Midland	363,315	59,291	320,985
5,145	15,499	106,337	South Midland	326,790	87,211	441,702
5,032	16,197	74,028	South Wales	176,645	40,958	171,009
9,742	22,018	114,377	North Wales	419,928	164,834	470,943
2,655	7,870	98,326	N. Western Region	467,349	206,364	1,010,698
8,776	6,724	22,560	Northern Ireland	41,924	13,656	92,024
14,068	21,179	142,705	N. Eastern Region	515,254	144,550	770,205
25,179	31,613	143,898	Scottish Region	435,178	89,377	586,479
101,020	194,292	1,207,292	Totals	4,002,657	2,248,697	8,285,803
106,460	197,413	1,178,530	Totals as at 30th June, 1939	3,951,849	2,159,456	8,093,676

\* Includes all spare wires. § All wires (including spares in MU cables.) † All wires (including spares in wholly junction cables).  
‡ All wires (including subscribers and mixed junction and subscribers cables).

# Baldock Radio-Telephone Receiving Station

U.D.C. 621.396.722

G. T. EVANS and  
J. E. LUCKHURST

The article gives a general description of the equipment provided at Baldock, serving the overseas radio-telephone links from 12 different countries as well as from liners on the North Atlantic route.

## Introduction.

FOLLOWING the marked success of the pioneer radio-telephone circuit opened in 1927, linking England and the U.S.A., and the successful results of communication by short wave which subsequently developed, telephone subscribers in Great Britain have, through the engineering effort of the British Post Office, been placed in communication with practically the remainder of the important telephone areas of the world. The important facility of radio-telephone communication to the overseas Dominions, not to mention the historic broadcast programmes which have been received and transmitted over these circuits, has been wholly developed during the past decade. Although these services have been temporarily interrupted by the outbreak of hostilities it is thought that a general description of the Baldock receiving station might be of interest as marking the progress of the art up to the present time.

The British Post Office overseas radio-telephone receiving station is situated near Baldock in Hertfordshire, 40 miles from London. The station is alongside the Icknield Way, a prehistoric trackway that leads from the Berkshire Downs across the Thames and along the Chilterns to Cambridge. It is about 4 miles south of the point where Ermine Street—the Roman road to the north—crosses the Icknield Way. Burial mounds, of the bronze age and the Roman period nearby, are witnesses of the site's antiquity. Adjacent are one or two examples of the moated homestead of the 12th-14th centuries when such protection was necessary against wolves and other enemies.

In 1929 a site of 900 acres in extent was acquired for

the concentration of short wave telephony reception from overseas. The ultimate capacity of the station then envisaged was for one long wave and sixteen short wave receiving systems. Such a large site for the receiving station was chosen for several reasons, notable among which was the far sighted policy of securing improved communication by the building of elaborate directive receiving antennae, termed "arrays." These arrays give an improvement of 20 db. or so in the reduction of atmospheric disturbance, except when the direction of the atmospheric is coincident with that of the arriving signal, thus the use of the array is relatively as effective as a 100 times increase in the power of the distant transmitter. The augmented input on weak signals is also an important factor in increasing the ratio of signal to thermal noise which is generated in first circuits of the receiver. The arrays are led into a central receiving building by open wire transmission lines much after the fashion of ordinary land-wire routes. A photograph of the building is given in Fig. 1.

## Long-Wave Receiving System.

The main long wave transatlantic receiving station is situated at Cupar (Fife). Its northerly location is an important factor in the improved performance of the long wave radio-telephone circuit to the U.S.A. as a substantial reduction in atmospheric disturbances is achieved in higher latitudes. As a reserve near to London in the event of interruption to the main receiver equipment, or to the 400-mile underground line to London, the Baldock station is equipped with receiving plant for reception of the single sideband transmission from the U.S.A. on the wave-length of 5,000 metres. This long wave receiver at Baldock is fed from a directive type of antenna aligned on Rocky Point, Long Island. The manner in which this directivity is accomplished is largely due to the forethought of Sir George Lee who fostered the project.

The antenna system consists of four large loops with associated vertical antenna, arranged in pairs as in Fig. 2. Each loop aerial is spaced 0.25 of a wavelength, i.e., 1,250 metres, from its partner in the direction of the received signal and spaced 0.62 of a wavelength apart in a direction at right angles to that of the received signal. Each loop consists of four turns of bronze wire, spaced 4 ft. apart between turns, and supported between two 130 ft. steel towers, 200 yds. apart, the bottom of the loop being 20 ft. from the ground. Eight towers in all are employed. The vertical antenna is a single wire stretched between the two towers with a down lead to a small hut situated



FIG. 1.—BALDOCK RADIO-TELEPHONE RECEIVING STATION.



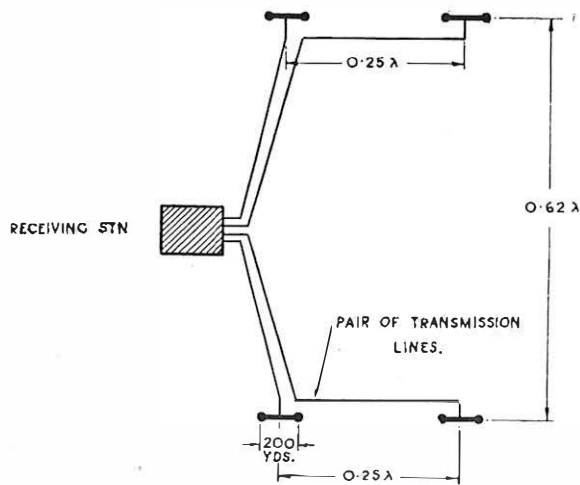

FIG. 2.—LONG-WAVE ANTENNAE SYSTEM.

at the centre between the towers. From the combination of the loop and vertical antenna a partial cardioid diagram is obtained similar to the well-known sense condition on a radio-goniometer. The combined output is fed via screened transformers and open wire transmission lines and lead-in cable to the antenna combining unit of the receiver. Here the signals are again combined in necessary amplitude and phase relationship to give the desired directional effects for reception as shown in Fig. 3. By the application of a direct current to the loops from the station, the vertical antenna can be disconnected. This facility is extremely useful when atmospheric arrivals from the southerly direction, and also when

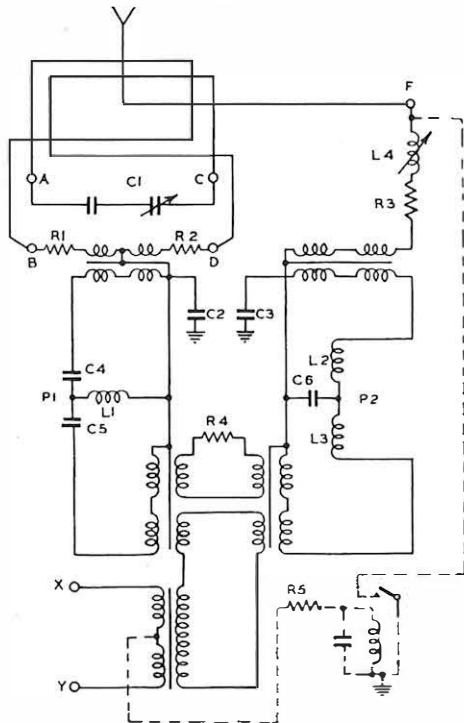

FIG. 3.—LOOP AND VERTICAL AERIAL COMBINING APPARATUS.

electrified rain storms are present. The latter produce hissing sounds which are minimised by disconnecting the vertical antenna. The following measured values of the antenna system may be of interest :—

- Inductance Loop = 5,000  $\mu$ H
- Capacitance Loop = 1,000  $\mu$  $\mu$ F
- Capacitance Vertical = 1,285  $\mu$  $\mu$ F
- Inductance Vertical = 340  $\mu$ H

#### Long-wave Receiver

The receiver is designed for the reception of single sideband telephone signals at suppressed carrier frequencies between 50 and 75 kc/s and was manufactured by Marconi's Wireless Telegraph Company to a Post Office specification, drawn up on experience

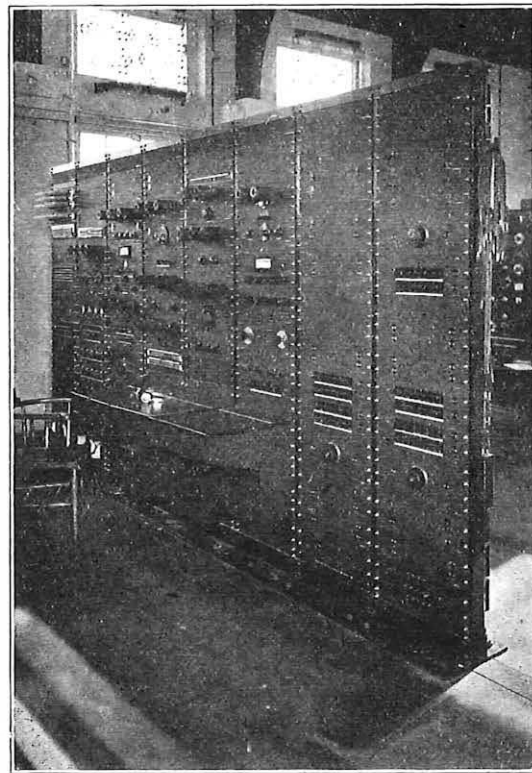

FIG. 4.—LONG-WAVE RECEIVER.

gained at Cupar. The receiver proper comprises antenna filters, first oscillator-demodulator, intermediate frequency filters and amplifiers and a second oscillator-demodulator.

The single sideband signals received are only changed in frequency by the first oscillator-demodulator, and it is not until the second oscillator-demodulator is reached that the equivalent of the suppressed carrier is reintroduced. Hence the bandwidth of all the apparatus preceding the second demodulator output transformer is that necessary for a single sideband. It can also be seen that the original suppressed carrier frequency must be equal to either the sum or difference of the frequencies of the receiver oscillators, according to the method of overall

working adopted. At Baldock the difference of the two receiver oscillator frequencies is used.

The oscillator-demodulator output is taken through low- and high-pass filter sections to the intermediate frequency amplifiers, so that these amplifiers shall not be affected by the unneeded sidebands produced in the demodulation. The demodulator is also made of the balanced type to reduce the output of the first oscillator frequency.

To reduce noise, the two intermediate frequency amplifiers are succeeded by a high-pass filter and then by a low-pass filter, the latter being designed also to eliminate any harmonics produced by the intermediate frequency amplifiers. From these filters, the output passes to a second oscillator-demodulator of the balanced type, the voice frequency output of which is transmitted to line via low-frequency filters and a line amplifier. A photograph of the receiver is shown in Fig. 4.

#### SHORT - WAVE RECEIVING SYSTEM

Particulars of the countries with which there is directive reception at Baldock, together with the dates of the opening of the several services, are given in the table on this page.

For these services over 40 short-wave receiving arrays and 20 dipoles are at present employed at Baldock. As is well known the characteristics of short-wave propagation vary according to the period of the day and season of the year and, in order to provide a service covering the 24 hours of the day, as many as three or more frequencies must be employed for long distance communication.

This necessarily involves the provision at the receiving station of a similar number of receiving arrays as the frequency response of the array, and hence its electrical performance is limited by the mechanical dimensions of the array and its associated reflector. The arrays are of several types, known as single and double Bruce, vertical and horizontal Koomans, and Horizontal T.W. type developed by

Dr. T. Walmsley<sup>1</sup>; the recently developed Rhombic loop antennæ<sup>2</sup> are also employed. The arrays and Rhombics have their maximum receiving sensitivity fixed in the direction of the corresponding distant transmitter, and the angle of reception is generally confined to about 10 degrees on either side of the great circle bearing of the distant transmitter, the amount of signal or noise received beyond this angle being

Country Terminal in brackets	Location of Station		Distance between Circuit Terminals (Statute Miles)	Date Service opened
	Transmitting	Receiving		
U.S.A. (new York) Channel 1 (long Wave) Channel 2 Channel 3	Rocky Point	Houlton Maine	3,450	7.1.27
	Lawrenceville	Netcong	3,450	6.6.28
	Lawrenceville	Netcong	3,450	1.6.29
				(single channel) 18.12.38
Channel 4	Lawrenceville	Netcong	3,450	(twin channel) 1.12.29
				(single channel) 1.8.38
				(twin channel)
Australia (Sydney)	Pennant Hills	La Perouse	10,560 (short route) 13,800 (long route)	30.4.30
Canada (Montreal)	Drummondville	Yamachiche	3,250	11.7.32
South Africa (Cape Town)	Klipheuveel	Milnerton	6,010	1.2.32
Brazil* (Rio de Janeiro)	Sepetiba	Taquara	5,770	21.5.31
	Marapiece	Jacarepagua	5,770	26.4.37
Argentina* (Buenos Aires)	Monte Grande	Villa Elisa	6,920	12.12.30
	Hurlingham	Platanos	6,920	12.12.30
India (Bombay)	Kirkee	Dhond	4,470	1.5.33
Egypt (Cairo)	Abou Zabal	Mahdi	2,180	22.6.32
Japan (Tokio)	Nazaki	Komuro	5,940	13.3.35
Iceland (Reykjavik)	Vatnsendahad	Gufumes	1,180	1.8.35
Kenya (Nairobi)	Kabete	Ngong	4,250	7.3.36
Portugal (Lisbon)	Alfragide	Vandas Novas	950	10.8.37
Marine Service (Large Liners on Nth. Atlantic trip)	—	—	3,450 (Maximum)	3.1.30

\* There are two separate radio telephone organisations at these places.

generally reduced by about 14 to 22 db. of that on this axis. A description of a similar type of array employed for transmission at the Rugby station was given in the April issue of this JOURNAL<sup>3</sup>. A measured

<sup>1</sup>Journal I.E.E., 1931, Vol. 69, p. 299.

<sup>2</sup>Proc. I.R.E., 1935, p. 24.

<sup>3</sup>P.O.E.E.J., Vol. 32, p. 16.

polar diagram of a T.W. array is shown in Fig. 5.

At present there are 27 steel latticed towers, each 120 ft. high (Fig. 6) and two wooden towers 100 ft. high supporting the arrays. The towers are of the self-supporting type.

The overhead transmission lines, from the arrays to the station, are distributed to the appropriate receivers by a flexible system of open wire lines within the receiving room, which permits of interconnection of any array to any receiver. Lightning arresters are provided both at the array and the receiver

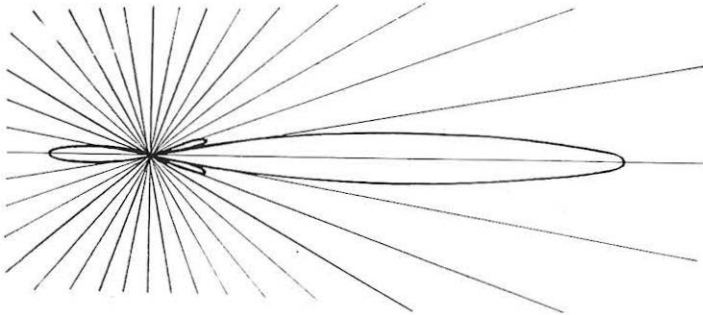

FIG. 5.—POLAR DIAGRAM OF "TW" ARRAY.

terminations: these take the form of neon discharge tubes associated with a tuned circuit placed across the transmission line.

It is interesting to note that, depending on the daylight track between Australia and this country, the waves may be received at Baldock from at least two directions in the great circle path. One known as the short route, of 10,500 miles, is over Asia and Scandinavia and the other of nearly 14,000 miles across the South Pacific, S. America and the Atlantic. The Australian array has therefore been made reversible. This is accomplished by the provision of separate transmission lines to the aerials and reflectors, the direction of reception being readily reversible.

Another reversible array serves Buenos Aires and Shanghai<sup>4</sup> at alternate periods. It so happens that Baldock is situated on the great circle path between these centres. Only one transmission line is used for this array, the switching being done at the array itself by a small motor switch remotely controlled from the receiving room approximately half a mile away.

#### Short-wave Receivers.

Thirteen short-wave and one long-wave receivers are contained in one large room. The receivers are constructed on the unit principle mounted on standard 19 in. racks 6 ft. 6 in. high. The normal frequency range of the S.W. receivers is from 21 Mc/s to 3 Mc/s (13-100 metres), and to ensure that wavechanging can be done quickly

<sup>4</sup>The service to China is suspended owing to hostilities.

most receivers have three separate R.F. input circuits. Each receiver is allocated to a particular service. It should be kept in mind that the design of the receivers is dependent to a large extent on the nature and characteristics of the particular service and distant emission respectively. Two of the receivers, for example, are of the single sideband, double channel type enabling the reception of two conversations simultaneously on each receiver as previously described in this JOURNAL<sup>5</sup>. Another receiver is provided with six input circuits designed to operate two services on a forked basis, or when two services are shared at short periods on the same receiver, a rapid changeover thus being possible. A schematic diagram of such a receiver is shown in Fig. 7.

The normal type of receiver at Baldock employs the double detection (superheterodyne) method of reception and is provided with automatic gain control arrangements which are effective over a range of 50 db. variation in signal strength. Most of the selectivity of the receiver is provided in the intermediate frequency filter. Usually there are two stages of amplification before the first demodulator, thus ensuring adequate image channel discrimination. Then follows the intermediate frequency filter and variable attenuator preceding the I.F. amplifier, in which three or more stages provide most of the gain of the receiver, which is approximately 120 db. For the reception of music broadcast programmes the frequency bandwidth of the receiver is extended to 5,000 c/s from the 3,000 c/s normally employed for speech. Severe interference would be experienced if the pass-band were extended beyond the former figure on account of the frequency allocation for other commercial services. The output of the receivers is fed through a central monitoring position which is connected to the radio terminal at Carter Lane, London, by underground cable.

<sup>5</sup>P.O.E.E.J., Vol. 11, p. 24.

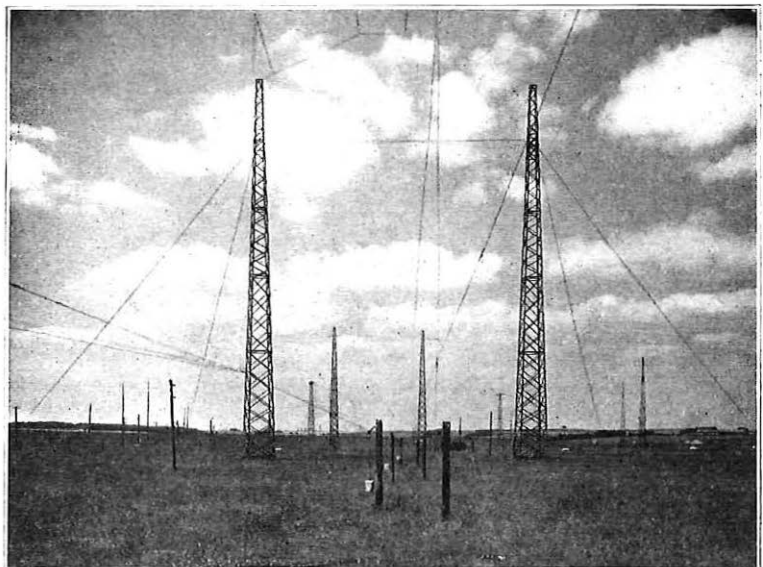

FIG. 6.—120 FT. MASTS FOR SHORT-WAVE RECEIVING ARRAYS.

FIG. 7.—SCHEMATIC DIAGRAM OF SHORT-WAVE RECEIVER FOR FORK WORKING.

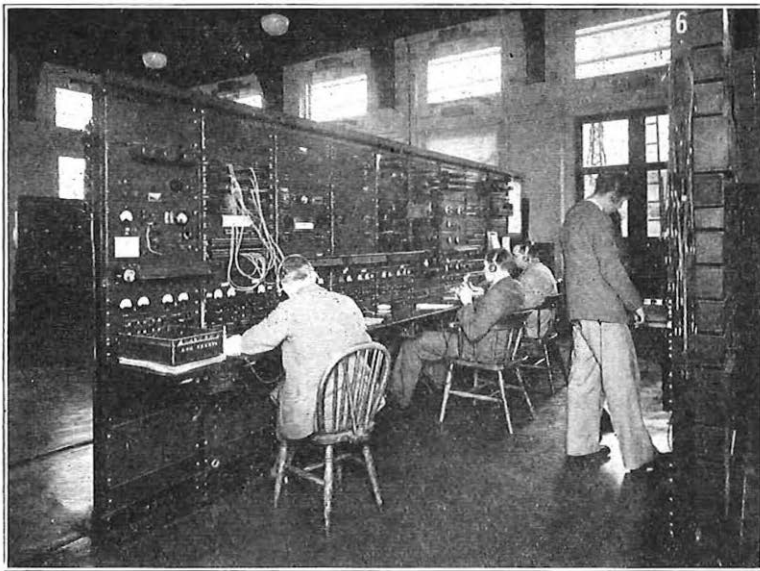
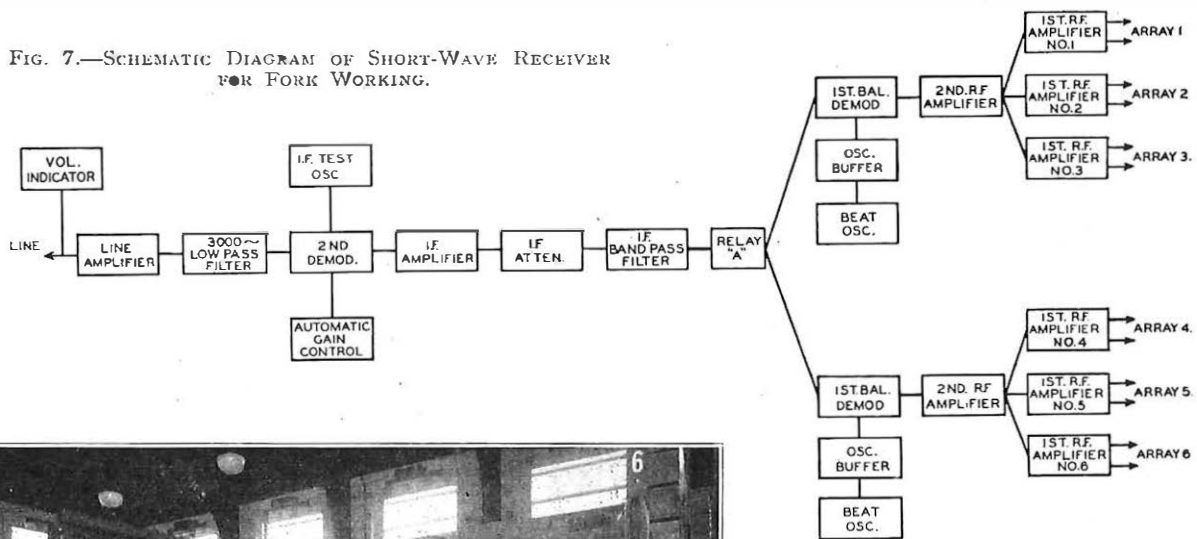

FIG. 8.—RECEIVING ROOM CENTRAL TEST AND CONCENTRATOR POSITIONS.

*Central Monitoring Position.*

Monitoring of the receivers is concentrated at the central position in the receiving room. Facilities are provided for continuous monitoring by one operator of up to four radio receivers. Two meters for each

circuit are provided, one for the audio output and the other to indicate the strength of the received carrier. A view of the Central monitoring position is shown in Fig. 8.

*Power and Water Supplies.*

The station power supply is obtained from the North Metropolitan Power Company. Rectifier and storage batteries provide 24 V and 120-200 V D.C. supplies. The capacity of the L.T. battery is 1,400 Ah. In the event of failure an emergency power plant is provided from a 27 h.p. oil engine; automatic starting of this engine takes place immediately the normal power supply fails. The station water supply is obtained from an artesian well, the water being fed to the reservoir by an electrically driven pump.

# Stream-Damming

U.D.C. 627.4 : 621.315.285

A. T. SOONS

The author gives some practical notes on the methods adopted to dam small watercourses to allow the laying of conduits and gives references to other articles dealing with the crossing of larger, navigable rivers.

## Introduction.

AS a departure from the ordinary run of conduit-laying works the crossing of small non-navigable rivers and streams by conduit routes trenched in river beds may be cited, as the operations call for rather more than ordinary care and advance planning. This work, like tunnelling under streets, is necessarily costly, and is only resorted to when there is no possibility of following the course of the highway over a bridge spanning the stream. Failure to obtain accommodation on the bridges may be due to narrowness and/or shallow depth of the roadway, or to weakness of the structure or to other difficulties that rule out the possibility of carrying steel pipes on the outsides of bridge structures.

Other methods of negotiating the stream must then necessarily be considered, and where a single cable will meet ultimate requirements the cheapest form of construction is to trench the river bed and lay an armoured cable. Where more than one cable is required, the laying of steel pipes in the bed of the stream may be considered.

With the exception of streams that have dried up

## Survey.

Such preliminaries as wayleaves and agreed working conditions having already been arranged with the "body having control of the stream," in the absence of reliable local knowledge a careful survey of the bed of the stream should be undertaken prior to commencement of damming operations. Soundings should first be taken to determine the depth and the gradient between the water's edge at each bank and the centre of the stream. Where the stream is too deep to allow this operation to be carried out by men in waders, a boat or raft will be required. The vessel will be worked across the stream along a hawser made fast to each bank, and at predetermined intervals soundings are taken with a lead-weighted line, showing the depth from the water level to the bed of the stream (Fig. 1).

The readings are recorded and a "bed" contour plotted to scale. This diagrammatic record (Fig. 2) serves the dual purpose of indicating the depth of the stream and providing means for setting out to scale a template for bending the steel pipes to conform to the contour of the bed of the stream.

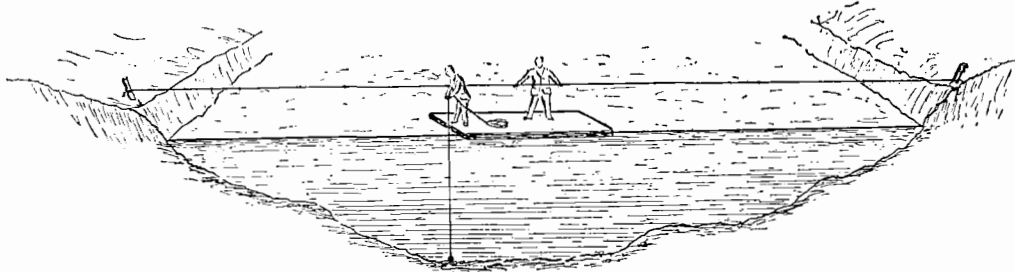

FIG. 1.—TAKING READINGS OF THE DEPTH OF THE RIVER BED.

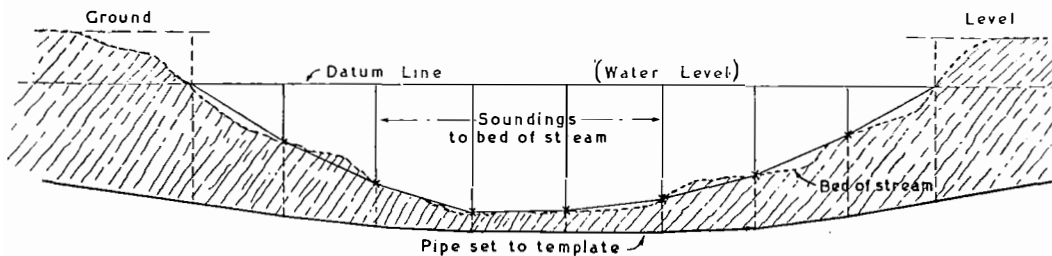

FIG. 2.—BED CONTOUR.

during a spell of dry weather, or those which are small and very narrow when an under-water trench can be excavated by men wearing waders, or where the use of a drag scoop is possible, the usual method of crossing streams of fair width is to form a dam to control the water while pipe-laying operations are in progress. The methods of damming to be employed for controlling the water will vary according to site conditions, e.g. consideration of width and depth, nature of bed, rate of flow, and tidal or non-tidal nature of the stream. The dam walls may be comprised of steel piling, timber piling, fenders filled with clay or barriers formed of clay-filled bags.

Distance from Bank	Depth from Water Level	Bank Height above Water Level
Feet	Inches	Inches
6	15	17
12	27	—
18	35	—
24	34	—
30	32	—
36	26	—
42	13	19

### *Damming and Coffer-damming.*

Where the stream is so very small and shallow that trenching and pipe-laying can be completed within a few hours, complete stoppage of the water is probably permissible by constructing a simple "dam" or single barrier, in earth or clay, behind which the water may be allowed to "head up" during progress of the work.

Where, however, the flow of the stream is beyond the scope of this method it becomes necessary to construct a "coffer-dam." This is a box-like enclosure built in the stream.

#### *Construction of a Coffer-Dam.*

Coffer-dams may be constructed of bags filled with clay, timber piles or metal piling sheets. Where clay-filled bags are used, these are "laid to bond" (Fig. 3) in a similar manner to bricklaying, i.e. each

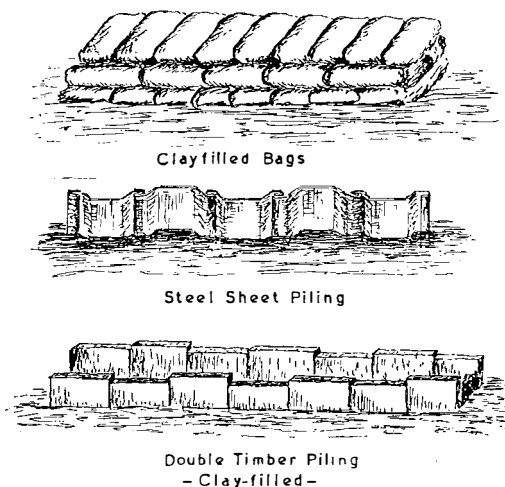

FIG. 3.—METHODS OF DAM CONSTRUCTION.

tier of bags is laid alternately to header and stretcher course, and the interstices between the bags are pugged with clay to minimise the percolation of water. Where timber or metal piling is used, care must be exercised to select a length which will give sufficient depth of penetration into the bed of the stream and a safe height above the water level.

If pile driving is necessary a raft must be constructed from which to work a simple pile-driving

device, such as is shown in Fig. 4. It will be seen that the raft is constructed with a bay at one end, which provides room for men to move about on either side of the pile-driver, to steady the pile while it is being driven. Furthermore, the bay extension assists in maintaining an even distribution of weight, minimises tipping and allows the raft to be moved along without disturbance of the last-driven pile.

The simple manually-controlled pile-driving device is a winch erected upon sheer-legs together with a suitable weight (called the monkey) as a rammer. The driving wheel, or rack wheel, is a cogged wheel with one quadrant cut away. This wheel is geared to the pinion of a horizontal capstan upon which a rope attached to the "monkey" is wound. The "monkey" is drawn up a guide to the top of the sheer-legs by turning the crank handle attached to the driving wheel, and as soon as the driven pinion enters the "cut-away quadrant" section of the driving wheel the capstan is released allowing the "monkey" to drop upon the pile; this operation is repeated until the pile is driven to the required depth.

Steel piling is comprised of sections of rolled steel sheeting, trough-shaped to secure maximum stiffness of individual members, and provided with interlocking edges to form a self-supporting continuous wall that will stand firmly against a considerable head of water and be reasonably water tight against seepage through the interlocking joints.

If steel piling is used a single wall only is necessary, but if timber is used a double wall having a cavity 9 to 12 in. in width must be erected. Clay is well punned into the cavity to make a water-tight enclosure and to reduce seepage to a manageable level.

Where a horizontal fender is to be used it is first necessary to drive separate wood piles (6 in. to 9 in square) into the stream bed at, say, 6-ft. intervals. Stout boards are secured, by timber dogs, to each side of the driven pile, so forming a cavity into which clay is placed and solidly punned. As the clay is punned into the cavity the water is forced out and a water-tight wall is secured.

#### *Half and Full-width Dams.*

Where the rate of flow of the stream is considerable it may be advisable to divide the work into two

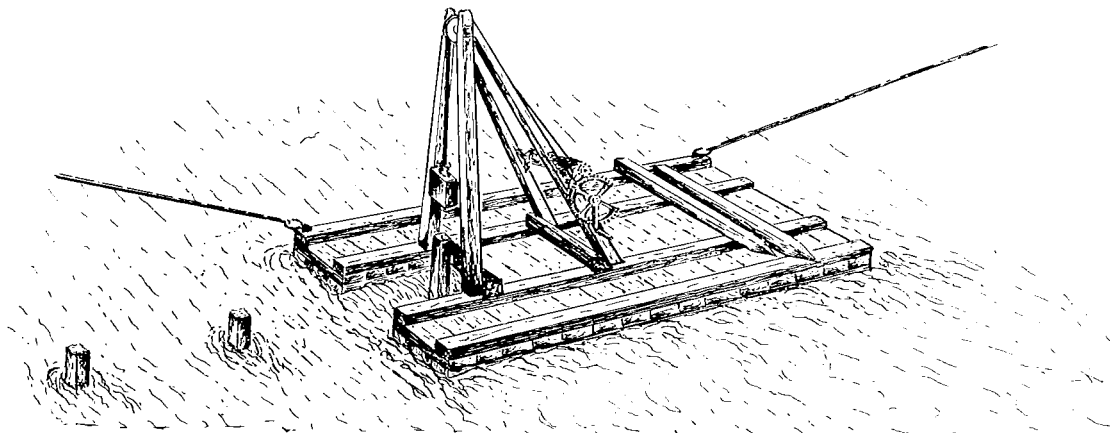

FIG. 4.—SIMPLE PILE-DRIVING RAFT.

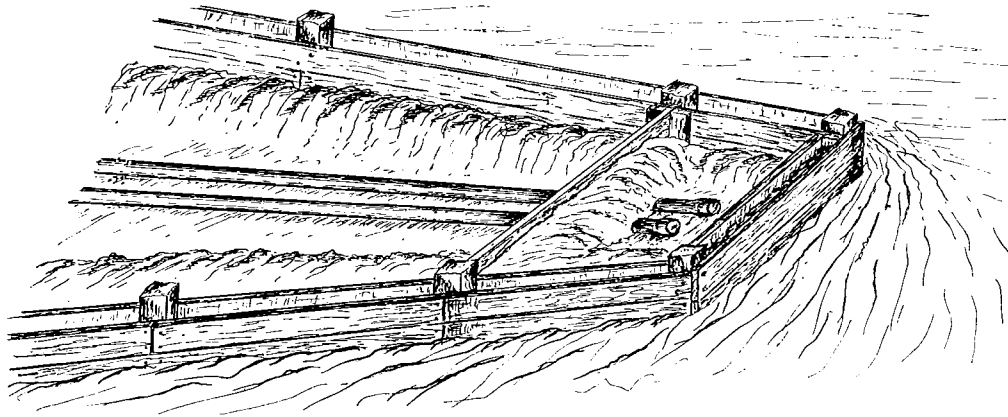

FIG. 5.—COFFER-DAM AND BULKHEAD.

portions by constructing a coffer-dam extending, say half-way across the stream and terminating in a short section constructed as a water-tight bulkhead (Fig. 5) for use when changing over to the second portion. This bulkhead is a short section about 6 ft. in length at the forward end of the dam, and is partly filled with clay after the pipes have been laid in it. After the trench has been filled in the first half of the coffer-dam is demolished to allow the stream to resume its course, and the damming of the remaining portion of the stream is then proceeded with.

When the stream is deep but the flow not so fast as to preclude "heading-up" to a considerable extent, a coffer-dam may be constructed for the whole width of the stream and provided with a sluice or water run-way across the centre (Fig. 6).

When practicable this method is preferable, as the trenching and pipe-laying work can be carried to completion before the dam is demolished.

#### *Pipe-laying and Jointing.*

Additional precautions in pipe-jointing should be

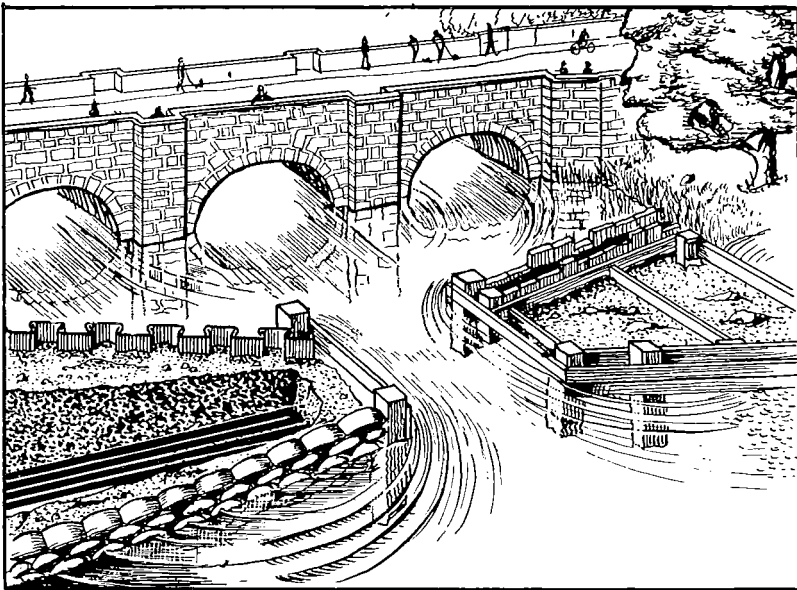

FIG. 6.—SKETCH OF MODEL CONSTRUCTED TO DEMONSTRATE METHODS OF DAMMING.

taken to prevent water gaining entry via the joints of the pipes, e.g. the joints may be welded in situ by a portable welding plant or alternatively screwed collars may be used. Whatever method of jointing is adopted, it is important to serve the exposed metal work at joints with approved preservative compound before filling in the trench.

The above methods are, as stated at the outset, limited to crossings of small non-navigable water-courses.

#### *Larger Works.*

The Post Office has carried out numerous crossings of navigable rivers and estuaries. Modern practice favours the excavation of a trench by a drag-scoop operated from bank to bank, an armoured cable being laid immediately the trench is dredged to the required depth. The trench is then allowed to fill by natural silting, supplemented where necessary by broken stone tipped from barges.

Pipe formations have been laid similarly, the pipes being assembled ashore on a runway, towed across the stream on a series of floats and lowered into the trench.

Subaqueous tunnelling has not been undertaken extensively by the Post Office, although many of its cables are "lodgers" in subaqueous tunnels and culverts provided by other undertakers. One subaqueous tunnel, however, was constructed in connection with the Manchester auto area underground scheme when a 36-way route was laid in a brick tunnel under the Manchester-Rochdale Canal. The work was described in an article by Mr. J. Cleaver in *P.O.E.E. Journal*, January, 1930.

Subaqueous thrust-boring has been carried out successfully, but does not call for comment other than reference to abnormal depth of working shafts and long lengths of boring.

#### *Bibliography.*

The following short bibliography is given to facilitate reference to the various recorded methods of subaqueous trenching for cables and pipe-lines:

Manchester-Rochdale Canal.

*P.O.E.E. Journal*, Vol. 22.

Booth Ferry (River Ouse).

*P.O.E.E. Journal*, Vol. 24.

Channel Sea River, Stratford. *The Engineer*, April 22nd, 1921.

# Notes and Comments

## Recent Appointments

Owing to the large number of staff changes consequent upon the extension of regionalisation it has not been possible to publish the usual personal paragraphs concerning the newly-appointed Staff Engineers, Chief Regional Engineers, etc., but we would like to take this opportunity of congratulating the following engineering officers on their recent appointments and wish them, on behalf of their many friends and colleagues, success and happiness in their new spheres :—

Mr. N. F. Cave-Brown-Cave, Deputy Regional Director, Home Counties Region.

Col. H. Carter, T.D., Deputy Regional Director, Scottish Region.

Mr. H. Faulkner, Deputy Regional Director, Welsh and Border Counties Region.

Mr. H. G. S. Peck, Staff Engineer, Equipment Branch, E.-in-C.'s Office.

Major L. H. Harris, Chief Regional Engineer, Midland Region.

Mr. L. E. Semple, Chief Regional Engineer, Home Counties Region.

Mr. J. Morgan, Chief Regional Engineer, South-Western Region.

Major H. A. Ashdowne, Chief Regional Engineer, Scottish Region.

Mr. H. A. Smith, Chief Regional Engineer, Welsh and Border Counties Region.

During the absence on military service of Major Harris and Major Ashdowne, the Chief Regional Engineerships of the Midland and Scottish Regions will be filled by Messrs. E. A. Speight and H. C. Davis respectively.

## A.R.P. Lighting Restrictions

The Electric Lamp Manufacturers Association of Great Britain, Ltd., has called our attention to the exhibition of lighting under war-time conditions which they are holding at their Lighting Service Bureau, 2 Savoy Hill, London, W.C.2. The Association is anxious to help as many people as possible to obtain the maximum benefit from their lighting during war time.

## Lt.-Col. W. A. J. O'Meara, C.M.G., R.E.

We regret to record the death at Guildford, on November 16th, 1939, of Lt.-Col. W. A. J. O'Meara, C.M.G., R.E., at the age of 76. The older of our readers will recall that, after distinguished service in the Royal Engineers, during one period of which he was engaged on Post Office engineering work in the Southern District of England, he—as Major O'Meara—was appointed Assistant Engineer-in-Chief in April, 1902, and succeeded Sir John Gavey, C.B., as Engineer-in-Chief, in March, 1907. He retired from that position in February, 1912, shortly after the transfer of the National Telephone Company's undertaking, and, on the outbreak of war in 1914, returned to the Army and served on the general staff to the end of the war. He was a man of wide professional interests, and at the age of 50 was called to the Bar. He was associated during the period from 1902 to 1912 with many developments and changes of practice affecting the Post Office Engineering Department—looked at retrospectively, the most important was probably the introduction of Civil Service competitions for the purpose of filling a proportion of the vacancies for Assistant Engineers and Inspectors.  
J.W.A.

# Junior Section Notes

## Chichester Centre

Prevailing conditions have not yet adversely affected the Centre and, contrary to expectations, the present session opened very briskly. With possibly one exception every paper will be given by a local member and, for the first time, the Essay Competition will include entries from Chichester.

The Chairman and Officers of the Committee are :—

Chairman—M. W. V. Brown.

Vice-Chairman—H. V. Titcombe.

Local Secretary—H. J. Robinson.

Local Treasurer—J. W. Scutt.

And the programme for the session is as follows :—

September 29th.—“Gases and Incendiary Bombs.”  
Mr. Trotter.

October 20th.—“Voice Frequency Telegraphy.”  
Mr. F. W. Greenaway.

November 27th.—“U.A.X.s 7 and 14.” Mr. R. H. Scutt.

December 15th.—“Youths - in - Training, 'A' Course.” Mr. R. Smith.

January 19th.—“Sound.” Mr. H. S. Pennicott.

February 23rd.—“Road Traffic Signals.” Mr. C. E. Lund.

March 29th.—“Automatic Telephony.” Mr. F. S. Huggett.

April 26th.—“An Outline of Transmission.” Mr. F. J. Bridger.

May 10th.—General Meeting. Election of Officers, Session 1940-41.

A further item of interest is the recent decision of the Centre to procure a bookcase to hold the Centre's file of Engineering Instructions and other technical literature which is the property of the Centre. The bookcase is to be placed in the External Linemen's Room at Chichester Head Post Office.



### London Centre

By this time members will have heard that the arrangements made for the 1939/40 programme have been cancelled. They should, however, note that library facilities and periodicals are still available, and the issue of an improved type of diary is to hand.

It is hoped that the response to the recent appeal for outstanding subscriptions will enable the commitments of the Centre to be met.

The congratulations of the Centre are passed to Messrs. C. M. Murdoch-Smith and T. D. Juden, who were successful in obtaining Senior Section awards for papers read at local meetings last session.

Best wishes and good luck are extended to those of our members serving with H.M. Forces, and it is hoped that circumstances will soon permit the return to our normal activities.

### Slough Centre

At the last meeting of the Section the existing officers were re-elected. Due to the present upheaval no meetings have been possible, and the proposed visits to Trunks and the B.B.C. have had to be cancelled. The Committee have an excellent programme of talks arranged, but have decided that in view of the lighting and travelling restrictions, the session shall be held towards the middle of 1940. Members will be advised via the notice boards of any matters of importance.

## Regional Notes

### Home Counties Region

#### CABLE FAULT AT SHOREHAM-BY-SEA

A rather unusual type of cable fault was encountered at Shoreham-by-Sea on July 21st, 1939.

Two subaqueous cables cross Shoreham Harbour at a point where the River Adur drains into the sea. At low tide the sea flows out of the harbour leaving a mud bed with a narrow channel through which the river water passes.

The cables were originally laid on the bed of the harbour and across the basin of the river channel at a depth of 3 ft. This channel has become silted up during recent months at the same time that the river bed became eroded. The river water at low tide has followed a new course through the harbour and a deep gully about 20 ft. wide has been cut by erosion leaving the cables suspended from one side to the other. During the wet season of the year, a large quantity of water flows out of the river, and at low tide this cascades through the gully. The force of the water beating against the suspended armoured cables caused a mechanical oscillation which lasted during the low-water period of each tide. The amplitude of this oscillation could be seen to be about 3 in., and this finally caused a series of fractures in one of the lead sheaths. The cable, on being dug up, was found to be at 6 in. depth with the chains laid as weights almost entirely gone. This is a 300 pair/6½ lb. lead-covered cable and armoured with two steel tapes and 33-No. 8 steel wires.

### London Telecommunication Region

#### LONDON TRUNK EXCHANGE 2 V.F. EQUIPMENT

On October 15th and November 19th, 1939, further steps in the introduction of 2 V.F. Trunk Working were made when the 2 V.F. dialling facilities were extended to Plymouth and to an additional 34 incoming Bristol circuits.

A total of 112 circuits have now been transferred to trunk 2 V.F. dialling. The disposition of the circuits is as follows:—

Trunk Bristol Area—29 outgoing circuits.  
37 incoming.  
10 bothway.

Trunk Plymouth Cts.—12 outgoing.  
12 incoming.  
12 bothway.

The change-over has been effected without any difficulties and the service is working satisfactorily.

### North-Western Region

#### DUCT LAYING ACROSS THE RIVER EAMONT

The laying of an 8-way duct in connection with the Leeds-Carlisle-Edinburgh route over the River Eamont, near Penrith, presented rather a unique problem for the Lancaster engineers. The bridge, which forms part of the main A6 road, is very narrow and has a severe hump. The road authority had a proposal in hand for reconstructing and widening the bridge, but this could not be put in hand simultaneously with the duct-laying. It was therefore decided to lay eight 3½ in. W.I. screwed pipes under the river bed and terminate them in a man-hole at each end. The section length is approximately 90 yards. The method adopted was to dam one-half of the river at a time and divert the water from this half into the other half. To do this, a quantity of sandbags were filled with soil and placed in position in the river bed to form three sides of a rectangle, the river bank forming the fourth side. In a fairly dry period the sandbags were built up from the river bed



to above water level, and were allowed a day or two to consolidate, after which the water was pumped out of the rectangular enclosure and all leakages plugged up with clay. No difficulty was experienced in keeping the water inside the rectangle at a level low enough to permit of the trench being excavated.

Timbering of the trench was necessary due to the loose nature of the river bed. The trench was excavated rather more deeply than required for the pipes, thus providing a "sump" for water percolating through from the river, but a 4 in. pump adequately dealt with this water.

The laying of the pipes from one end presented no difficulty but, to prevent any water entering the pipes, they were supported above the level of the water in the sump during the progress of the work. On completion of the laying of the pipes and filling-in of the trench, a bulkhead was formed across the trench near the mid-stream ends of the pipes, sufficient length of the pipes being left to project through the bulkhead to allow for coupling them to the pipes to be laid in the second half of the river. The pipe ends were sealed with wood plugs. From this bulkhead the sandbags forming the dam for the first portion of the work were diverted to form the dam for the second. As the second half of the river was deeper than the first portion, the dam on the



up-stream side, instead of being formed to make a right angle with the river bank, was constructed so that the angle made with the river bank was greatly reduced; this facilitated the easy flow of the river.

The trench excavating and pipe-laying were then carried out in a similar manner to the first portion.

One difficulty, however, was encountered in this portion of the work, and that was due to the wood blocks sealing the ends of the pipes in mid-stream becoming swollen, and in the efforts to release them the bulkhead was weakened and resulted in an inrush of water. This, however, was eventually overcome and the work proceeded satisfactorily.

The photographs give some idea of the nature of the work.

A. S. C.

## North-Eastern Region

MR. R. S. DACOMBE

Many of our JOURNAL readers will have learnt with deep regret of the sudden death at Leeds, on October 16th, 1939, of Reginald S. Dacombe, Senior Draughtsman. It is some little consolation to know that he experienced no lingering illness and that his passing occurred within one hour of his customary cheerful "Good-night" to his colleagues.

After serving the ex-N.T. Co. as a draughtsman for eight years, Mr. Dacombe was transferred to the Post Office in January, 1912, taking up duty at Shrewsbury. Four years later he moved to the Birmingham Sectional Engineer's drawing office. During the 1914-1918 War, Mr. Dacombe served for a period of eighteen months as draughtsman on a naval training ship, and during this period gained considerable knowledge of submarines—how they are located, sighted and destroyed. At the end of his service with the Navy in 1919 he had attained the rank of Chief Petty Officer.

Shortly after his return to civilian duties, Mr. Dacombe was promoted Draughtsman Cl. I, and controlled the Birmingham drawing office for a period of seventeen years. The fact that the complement of draughtsmen in the Birmingham office rose during this period from six to eighteen is some indication of the post-war increase in engineering activities and developments.

Mr. Dacombe's next promotion was attained in August, 1936, and he was transferred to Leeds as Senior Draughtsman for the North-Eastern Region. This post was the first of its kind outside London, and placed him in control of eight drawing offices with a staff distributed among the Telephone Managers' Offices within the Region, and numbering approximately one hundred. During the three years he held this post, Mr. Dacombe had placed his valuable general knowledge of drawing office procedure at the disposal of all and sundry within the Region, and his likeable personality was reflected in his constant efforts to encourage and assist.

His loss is deeply mourned by all who knew him because they were all his friends.

## South-Western Region

INTRODUCTION OF 2 V.F. DIALLING

The conversion of the Bristol-London, Bristol-Plymouth and Plymouth-London trunks to V.F. dialling was completed on November 19th, 1939. All calls routed over the trunks connecting the Bristol, Plymouth and London zones are now completed by dialling from the O/G end. The necessity for the intervention of an operator to connect incoming calls to the respective multi-area is therefore eliminated.

The conversion had to be carried out in two stages to fit in with "emergency" conditions. The first emergency was of a traffic nature and called for a measure of relief to incoming traffic at Bristol; this was met by advancing the conversion of I/C circuits at Bristol to June, 1939, prior to completion of the installation of equipment by the contractors, Messrs. A. T. & E. Co., Ltd. The second emergency, a national one, necessitated postponement of the final conversion from September to November, 1939.

In view of the special requirements for 2 V.F. dialling in respect of adjustment to switches and associated relays, the introduction of this new feature has been most successful. Tribute is due to the work of Officers in the Engineer-in-Chief's office and the London and South-Western Regions and of the Contractor's Staff

engaged on the installation who have thus successfully completed this further stage in the development of long-distance signalling.

#### DAMAGE TO PLANT BY ESCAPED BALLOONS.

The recent high winds have been the cause of a number of unusual cross-country "events" in which the quarry has been one or more escaped balloons. In some instances the escaped balloon has dragged a trailing length of mooring cable behind it, and the course followed by the balloon before it could be captured and anchored has been clearly marked by a trail of damage caused to overhead plant in the neighbourhood. In the course of its sixty-mile flight one of these balloons brought down twenty-three spans of wire in eight widely separated localities, uprooted a 28-ft. M pole, isolated a small rural exchange and burnt out a leading-in cable. This last item of damage might have been

much more serious as it was caused by the trailing cable making contact between the Department's route and an H.T. route a considerable distance away, and indicates the necessity for extreme caution in carrying out repairs to any damage thought to have been caused by escaped balloons.

#### TRURO NEW EXCHANGE

The C.B. No. 12 Equipment at Truro was thrown spare by conversion to automatic working on September 26th, 1939; 754 subscribers and 171 trunks and junctions were cut over with only seven reported faults.

Truro Group Centre carries the major portion of the seasonal holiday traffic from Cornwall, and the new auto-manual exchange of 1,000 lines multiple and 17 positions will afford considerably improved facilities for handling this heavy volume of traffic.

## Book Review

"Modern Radio Communication," Volume I. 7th edition. J. H. Reyner, B.Sc., A.C.G.I., D.I.C., A.M.I.E.E., M.Inst.R.E. 334 pp. with 156 ill. Pitman. 5s.

When a book, a textbook moreover, runs to seven editions, it may well be considered a success. That this is so with "Modern Radio Communication, Volume I," is no doubt due in part to the fact that Mr. Reyner has judged to a nicety the breadth and depth of a book suitable for the Preliminary and Intermediate Examinations in Radio of the City and Guilds Institute. It is probably true to say that the great majority of candidates for these examinations are students at evening schools where the time for instruction is strictly limited. In these circumstances it is very helpful for a teacher to be able to recommend to his students a book in which they may find much of the material that he himself cannot find time to present.

The book comprises some 330 pages well printed and liberally illustrated. Mathematics have been introduced only where necessary, and those used are of a standard that should be well within the capabilities of the average evening class student in his second or third year. The first part of the book is devoted to simple D.C. and A.C. theory including the use of the  $j$  operator, and to descriptions of the physical construction of inductors, condensers, etc., used in radio. The study of radio communication itself is then introduced in easy stages and continued, until, by the time the end of the book is reached, many branches of the subject have been touched, ranging from direction finding to radio-frequency measurements and loudspeakers to the elimination of interference. Most of the chapters are followed by one or more numerical exercises, the answers to which are given at the end of the book. There are two appendices: one is devoted to simple trigonometry and the other introduces the decibel and describes certain attenuators; incidentally, Fig. 155 in the latter appendix is incorrect.

The style adopted is simple, and in this respect it is suitable for elementary students, but it is not always the style one would wish the students themselves to adopt. At times, for example, the choice of adverbs appears to be a little inelegant: on page 12 one may

read "... the variation ... which is almost invariably positive may be practically entirely offset ...". And later, on page 116: "The early receiver ... used tuning circuits of a size and construction not greatly less than at the transmitter." Occasionally the imagination is stimulated by such phrases as "thus the grid and anode move in opposition" (p. 140); and "... whereby it is possible to speak and receive concerts from America, Australia and other far-flung climes" (p. 179). In fact, when one reads in the paragraph following the last quotation that "Condenser microphones are very faithful but very insensitive," one can almost hear them breathe.

In view of the fact that this is the seventh edition it is surprising to find a number of important mistakes, some of which do not appear to be of recent origin. The author seems to be under the impression that the slope of the anode-current/grid-voltage characteristic of a valve gives a direct indication of the amplification factor. On page 128 it is stated that this slope is much steeper for a screen-grid valve than for a triode, owing to the greatly increased amplification factor. Both parts of this statement are, of course, wrong. The slope is not much steeper, and in any case it only gives an indication of the mutual conductance. The high amplification factor of a screen-grid valve is indicated by the closeness of the mutual characteristics for various anode voltages. On page 143 and again on page 222 we are told that if two oscillations of frequency  $f_1$  and  $f_2$  are added together the resultant oscillation has a frequency of  $(f_1 + f_2)/2$ ; fortunately for those authorities whose duty it is to maintain some sort of order in the ether, this is not so. A final example will be given from page 289: "We have seen that a normal electro-magnetic wave consists of vertical electric fields, following each other, first in one direction and then in the other. Such a wave is said to be *horizontally polarised*." Unfortunately the italics are the author's!

In spite of these criticisms the virtues of the book are outstanding. The author has clearly tried to make the path of the student easy and has succeeded. He will no doubt be rewarded by seeing his work remain a best-seller in its latest edition.

H. S.

# Staff Changes

## Promotions

Name	District	Date	Name	District	Date
<i>From M.T.O., Cl. I, to C.M.T.O.</i>			<i>From S.W.1 to Insp.</i>		
Burns, W. C.	E.-in-C.O.	25.10.39	Lowe, W. A.	N.E. Reg.	1.4.39
<i>From Exec. Engr. to A.S.E.</i>			Pullen, E. W. W.	Test Secn., I.dn.	27.4.39
Cox, W. S.	N. Mid. to N. Wa.	9.7.39	Smithson, W.	N.E. Reg.	3.7.39
Edwards, J. J.	E.-in-C.O.	1.9.39	Outhwaite, O.	N.E. Reg.	3.7.39
Plymen, H. S.	E.-in-C.O.	6.11.39	Denny, R. E.	N.E. Reg.	3.7.39
<i>From Exec. Engr. to Reg. Engr.</i>			Kelsey, T. G.	E.-in-C.O.	5.7.39
Ryall, L. E.	E.-in-C.O. to Scot. Reg.	23.11.39	Axford, C. J.	E.-in-C.O.	5.7.39
<i>From M.T.O., Cl. II, to M.T.O., Cl. I</i>			Hill, W. H.	E.-in-C.O.	5.7.39
Benzies, A.	E.-in-C.O.	25.10.39	Boraston, E. G. C.	E.-in-C.O.	5.7.39
<i>From Asst. Engr. to Exec. Engr.</i>			Young, S. A.	E.-in-C.O.	5.7.39
Wilson, F.	E.-in-C.O.	1.7.39	Elstree-Wilson, E. C.	E.-in-C.O.	5.7.39
Durkin, T.	N.E. Reg. to N.W. Reg.	2.7.39	Turner, G.	E.-in-C.O.	5.7.39
Campbell, P. J.	E.-in-C.O. to N. Ire. Reg.	3.7.39	Beacon, R. L.	E.-in-C.O.	5.7.39
Sturgess, H. E.	E.-in-C.O.	14.7.39	Whiddett, S. D.	E.-in-C.O.	5.7.39
Skeet, T. S.	N. Midland	17.7.39	Southwell, R. A. W. J.	E.-in-C.O.	5.7.39
Duff, J.	N.E. Reg. to N.W. Reg.	13.8.39	Johnston, J. A.	E.-in-C.O.	5.7.39
Hough, F. A.	Scot. Reg. to N.W. Reg.	12.9.39	Wicks, A. G. W.	E.-in-C.O.	5.7.39
Thatcher, C. H.	L.P. Reg.	28.9.39	Keansley-Brown, R. H. G.	E.-in-C.O.	5.7.39
Markey, J. M.	N.E. Reg.	29.10.39	Cook, W. H.	L.T. Reg.	2.5.39
Bevis, W. F.	E.-in-C.O.	1.11.39	Everett, J. W.	L.T. Reg.	26.4.39
Romain, W. A. B.	L.T. Reg.	20.11.39	Wright, F. M.	L.T. Reg.	24.4.39
<i>From A.T.O. to R.M.T.O.</i>			Lester, E. W.	L.T. Reg.	25.2.39
Wright, F. V.	B'ham to Edin. Area	21.11.39	Punshon, R. W.	L.T. Reg.	3.5.39
<i>From Physicist to Sen. Physicist</i>			Sparrow, L. F.	L.T. Reg.	7.5.39
Glover, D. W.	E.-in-C.O.	20.11.39	Moon, W. J.	L.T. Reg.	7.5.39
<i>From Chief Insp. to Asst. Engr.</i>			Hill, W. J.	L.T. Reg.	28.5.39
Benson, W. K.	N.W. Reg.	7.7.39	Coe, H. S. C.	L.T. Reg.	2.6.39
Carrette, A. D.	N.E. Reg.	9.7.39	Walters, F.	L.T. Reg.	18.6.39
Piggott, E. C. C.	N. Wa. to N. Mid.	21.8.39	Stevens, R. E.	L.T. Reg.	12.6.39
Horn, T.	E.-in-C.O.	21.8.39	Borwick, F. B.	L.P. Reg.	29.7.39
Gerrard, J.	E.-in-C.O.	24.8.39	Smith, A. F.	Eastern	9.9.39
Madgwick, J. M.	N.E. Reg.	1.9.39	Sutton, W. A.	Test Secn., B'ham.	11.9.39
Allies, H. J.	N.W. Reg. to N.E. Reg.	7.9.39	Jeffery, E. G.	Test Secn., Ldn.	11.9.39
Naylor, W. H. J.	E.-in-C.O.	12.9.39	Jones, T. S.	S. Wales	2.10.39
Wilcox, A.	E.-in-C.O.	12.9.39	Hodgson, A. J.	S. Wales	2.10.39
Voss, L. C.	Test Secn. Ldn.	6.10.39	Cecil, C. H.	S. Wales	2.10.39
Lumsden, R. S.	Scot. Reg.	6.10.39	Cook, F. F.	S. Wales	2.10.39
Browning, W. H.	L.P. Reg.	15.11.39	Davies, T. Y.	S. Wales	2.10.39
Hamilton, D. F.	Scot. Reg.	7.12.39	Bossom, R. C.	S. Wales	2.10.39
Boyd, W. J.	N. Ire. Reg.	7.12.39	Regan, D. J.	S. Wales	2.10.39
<i>From Asst. Physicist to Physicist</i>			Gould, J. S.	S. Wales	2.10.39
Rickard, E. F.	Test Secn., Ldn.	21.8.39	Thomas, E. B.	N. Wales	6.10.39
<i>From Chief Insp. to Chief Insp. with allowance</i>			Newson, H. F.	Eastern	9.10.39
Thomson, A.	Scot. Reg.	2.7.39	Rolfe, E. J.	E.-in-C.O.	5.10.39
<i>From Tech Asst. to Asst. R.M.T.O.</i>			Bruce, S. J.	E.-in-C.O.	5.10.39
Stokes, F. W.	Ldn. to N. Ire. Reg.	31.7.39	Williams, R. M.	E.-in-C.O.	5.10.39
<i>From Insp. to Chief Insp.</i>			Tait, W. A.	E.-in-C.O.	5.10.39
Brown, E. B.	L.T. Reg.	8.7.39	Croxson, V. E.	E.-in-C.O.	5.10.39
Postance, J. C. E.	E.-in-C.O. to N. Mid.	30.7.39	Butterworth, G.	E.-in-C.O.	5.10.39
Clark, R. J.	N. Wales	21.8.39	Warwick, H. A.	E.-in-C.O.	5.10.39
Smart, H. W.	S. Western	21.9.39	Blanchard, A. J.	E.-in-C.O.	5.10.39
			Steer, A. E.	E.-in-C.O.	5.10.39
			Lowne, H. R. B.	E.-in-C.O.	5.10.39
			Heptinstall, D. L.	E.-in-C.O.	5.10.39
			Thomas, E. A.	E.-in-C.O.	5.10.39
			Bale, A. E.	Test Secn., Ldn.	16.11.39
			Pawlett, W. K.	N. Midland	22.11.38
			Dixon, W.	N. Midland	22.11.38
			<i>From Mech.-in-Charge, Gde I, to Tech. Asst.</i>		
			Waterfield, A. J. B.	N. Ire. to Ldn.	20.8.39

## Transfers

Name	District	Date	Name	District	Date
<i>Exec. Engrs.</i>			<i>Asst. Engrs.</i>		
Taylor, H. M.	N.W. Reg. to S.W. Dist.	20.8.39	Webber, F. W. J.	E.-in-C.O. to S.W. Reg.	27.9.39
Hemborough, J. R.	E.-in-C.O. to Cardiff	20.8.39	Cohen, A. J.	E.-in-C.O. to W. & B.C. Reg.	25.9.39
Ackerman, H. M. V.	E.-in-C.O. to H.C. Reg.	17.9.39	Thorn, B. K.	E.-in-C.O. to Mid. Reg.	25.9.39
Hibbs, A.	Liverpool to Southampton	1.11.39	<i>Chief Insps.</i>		
Mead, F. C.	E.-in-C.O. to Liverpool	1.11.39	Gray, R. E.	S.W. to S. Mid.	5.6.39
<i>Asst. Engrs.</i>			Grew, A. W.	E.-in-C.O. to H.C. Reg.	17.9.39
Rousell, S. M. E.	E.-in-C.O. to L.T. Reg.	1.6.39	Banks, W. R.	E.-in-C.O. to H.C. Reg.	17.9.39
Bardwell, W. J.	E.-in-C.O. to H.C. Reg.	17.9.39	Thorn, F. W. J.	E.-in-C.O. to W. & B.C. Reg.	25.9.39
Naylor, W. H. G.	E.-in-C.O. to H.C. Reg.	17.9.39	Hancock, L.	E.-in-C.O. to Mid. Reg.	25.9.39
Gambier, J. E.	E.-in-C.O. to S.W. Reg.	27.9.39	Pritchard, F. E.	E.-in-C.O. to Mid. Reg.	25.9.39

**Retirements**

Name	District	Date	Name	District	Date
<i>A.S.E.'s</i>			<i>Asst. Engrs.—continued</i>		
Struthers, G. A.	E.-in-C.O.	31.5.39	Stradling, W. A.	E.-in-C.O.	31.8.39
Day, W.	E.-in-C.O.	31.8.39	Davis, H.	Test Secn., Ldn.	30.9.39
<i>Reg. Engr.</i>			<i>Chief Insps.</i>		
Johnson, A. S. A.	L.T. Reg.	31.5.39	Cattle, F.	Test Secn., Ldn.	31.8.39
<i>Area Engr.</i>			<i>Insps.</i>		
Craddock, G. W.	Manchester	2.8.39	Naylor, G.	S. Western	20.9.39
<i>Asst. Engrs.</i>			<i>Insps.</i>		
Moody, S.	S. Midland	30.6.39	Stace, R. J.	L.T. Reg.	27.7.39
Glass, B.	E.-in-C.O.	30.6.39	Towe, E. A.	L.T. Reg.	12.6.39
Jones, J. C.	E.-in-C.O.	30.6.39	Hatfield, W.	L.T. Reg.	11.6.39
Pinnock, A. E.	N.E. Reg.	31.8.39	Mason, C. A.	E.-in-C.O.	30.6.39

**Deaths**

Name	District	Date	Name	District	Date
<i>Area Engr.</i>			<i>Insp.</i>		
Smith, H. G.	Bournemouth	23.7.39	Noble, H.	N. Wales	14.8.39

**Appointments**

Name	District	Date	Name	District	Date
<i>Prob. Asst. Engrs.</i>			<i>Prob. Insps.—continued</i>		
Laver, F. J. M.	E.-in-C.O.	1.9.39	Sinnicks, A. C.	E.-in-C.O.	8.5.39
Harris, R. J.	E.-in-C.O.	1.9.39	Tresidder, W. M.	E.-in-C.O.	1.5.39
Lynch, A. C.	E.-in-C.O.	1.9.39	Neal, N. W.	E.-in-C.O.	1.5.39
Bomford, K. D.	E.-in-C.O.	1.9.39	Walker, E. H.	E.-in-C.O.	19.5.39
Broad, E. R.	E.-in-C.O.	1.9.39	Garnett, W. H.	E.-in-C.O.	1.5.39
Spinks, J.	E.-in-C.O.	1.9.39	Bailey, N. G.	E.-in-C.O.	1.5.39
Greenman, L. H.	N.W. Reg.	1.9.39	Marks, D. J.	E.-in-C.O.	1.5.39
Dobbie, A. K.	E.-in-C.O.	1.9.39	Gordon, S. C.	E.-in-C.O.	8.5.39
Martin, B. R.	N.E. Reg.	1.9.39	Yemm, H.	E.-in-C.O.	1.5.39
Stead, L. G.	E.-in-C.O.	1.9.39	Dafforn, D. G.	E.-in-C.O.	1.5.39
Jones, P. H.	E.-in-C.O.	1.9.39	Lee, L. R.	E.-in-C.O.	10.5.39
Ayers, E. W.	E.-in-C.O.	1.9.39	Bowers, F.	N. Western	
Hansford, R. N.	S. Eastern	25.9.39	Palmer, J. E.	N. Western	18.5.39
White, R. W.	E.-in-C.O.	1.9.39	Boyle, C.	N. Western	10.5.39
Janes, J. D. W.	E.-in-C.O.	1.9.39	Lewis, H.	N. Western	26.5.39
Ireland, J. C.	S. Eastern	1.9.39	Mackereth, W. W.	N. Western	1.5.39
Blake, K.	S. Midland	1.9.39	Gates, R. E.	S. Lancs	1.5.39
Jones, D. G.	S. Eastern	1.9.39	Hulme, R.	S. Lancs	5.5.39
Pilling, T.	N. Wales	1.9.39	Wright, G.	S. Lancs	1.5.39
Hales, A. C.	E.-in-C.O.	1.9.39	Powell, G. F.	S. Lancs	1.5.39
Draper, J. H. P.	L.T. Reg.	1.9.39	Carnson, L. B.	S. Lancs	22.5.39
Warner, M. G. R.	N. Wales	1.9.39	Rimmer, E. G.	S. Lancs	7.5.39
<i>Prob. Insps.</i>			<i>Prob. Insps.—continued</i>		
Burchell, J. R. L.	E.-in-C.O.	1.5.39	Whittaker, E. N.	N. Midland	1.5.39
Jones, D. C.	E.-in-C.O.	1.5.39	Reid, H. A.	N. Midland	1.5.39
Galloway, J.	E.-in-C.O.	1.5.39	Astle, E.	N. Midland	10.5.39
Hunt, C. S.	E.-in-C.O.	1.5.39	Norfolk, J. D.	N. Midland	3.5.39
Keep, J. F.	E.-in-C.O.	1.5.39	Thorne, N. W.	N. Midland	1.5.39
Gausden, S. H.	E.-in-C.O.	1.5.39	Emms, W. G.	S. Midland	8.5.39
Masdin, R. M.	E.-in-C.O.	1.5.39	Unwin, J. H.	S. Midland	1.5.39
Seager, E. F.	E.-in-C.O.	1.5.39	Harvey, A. G.	S. Midland	3.5.39
Smith, A. F. C.	E.-in-C.O.	1.5.39	Pearce, H. J.	S. Midland	31.5.39
Hales, J. T.	E.-in-C.O.	1.5.39	Pelt, H.	S. Midland	29.5.39
Venus, A. L.	E.-in-C.O.	1.5.39	Saxey, A. E.	S. Midland	25.5.39
King, E. S. F.	E.-in-C.O.	1.5.39	Stubbington, C. J.	S. Midland	
Davidson, C. F.	E.-in-C.O.	8.5.39	Wooster, C. B.	Eastern	1.5.39
Looser, R. C.	E.-in-C.O.	1.5.39	Barley, N.	Eastern	6.5.39
Mills, R. J.	E.-in-C.O.	1.5.39	Fenwell, J. A.	Eastern	1.5.39
Phillips, G. J. A.	E.-in-C.O.	4.5.39	Linney, H. H.	N. Wales	1.5.39
Roberts, F. F.	E.-in-C.O.	1.5.39	Eley, A. C.	N. Wales	1.5.39
Haworth, J. E.	E.-in-C.O.	1.5.39	Eccles, J.	N. Wales	1.5.39
Ansell, G. V.	E.-in-C.O.	4.5.39	Soames, G. A.	S. Wales	3.5.39
Thompson, J.	E.-in-C.O.	3.5.39	Sheppard, J.	S. Wales	1.5.39
Stead, L. G.	E.-in-C.O.	1.5.39	Longyear, J. W.	S. Wales	1.9.39
Littler, C.	E.-in-C.O.	1.5.39	Horne, J. K.	S. Western	1.5.39
Parker, P. N.	E.-in-C.O.	1.5.39	Saunders, J. C.	S. Western	1.5.39
Roberts, T. N. D.	E.-in-C.O.	29.7.39	Tough, J. L.	S. Western	1.5.39
Norman, J. M.	E.-in-C.O.	1.5.39	Batland, T. K.	S. Western	1.5.39
Cobbe, B. M.	E.-in-C.O.	1.5.39	Farrow, C. F.	S. Western	1.5.39
Row, L. N.	E.-in-C.O.	1.5.39	Ward, C. V.	S. Western	3.5.39
Bourne, K. W.	E.-in-C.O.	24.5.39	Upchurch, S. W. J.	S. Eastern	1.5.39
Croisdale, A. C.	E.-in-C.O.	10.5.39	Slingo, F. W.	S. Eastern	1.5.39
Light, R. W.	E.-in-C.O.	1.5.39	Lane, G. W. H.	N. Ireland	1.5.39
Bennett, R. O.	E.-in-C.O.	3.5.39	Harvey, V. J.	Test Bch.	1.5.39
Woodford, R. A.	E.-in-C.O.	1.5.39	Lunt, L. S.	Test Bch.	1.5.39
			Stafford, L.	Test Bch.	1.5.39

CLERICAL GRADES

Promotions

Name	District	Date	Name	District	Date
<i>From H.C.O. to Staff Officer</i>					
Peak, H. C. . . . .	Brighton T.M.O. . . . .	3.6.39	Devonshire, A. E. . . . .	E.-in-C.O. . . . .	4.11.39
Gentleman, H. . . . .	Scot. West. . . . .	3.6.39	Griffiths, C. . . . .	E.-in-C.O. . . . .	29.10.39
<i>From E.O. to Staff Officer</i>					
La Croix, A. . . . .	E.-in-C.O. . . . .	5.6.39	Magness, W. H. . . . .	E.-in-C.O. . . . .	29.10.39
Oliver, S. R. . . . .	E.-in-C.O. . . . .	5.6.39	Winfield, A. L. . . . .	E.-in-C.O. . . . .	17.11.39
Dummer, J. F. . . . .	E.-in-C.O. . . . .	1.8.39	Samuels, W. H. . . . .	E.-in-C.O. . . . .	26.10.39
Foord, F. C. . . . .	E.-in-C.O. . . . .	5.6.39	Ellis, J. F. . . . .	E.-in-C.O. . . . .	4.12.39
Harrison, A. E. . . . .	E.-in-C.O. . . . .	1.8.39	Ledger, F. H. . . . .	E.-in-C.O. . . . .	4.12.39
Boyd, R. . . . .	E.-in-C.O. . . . .	23.10.39	<i>From C.O. to H.C.O.</i>		
Buxton, A. D. . . . .	E.-in-C.O. . . . .	13.11.39	Tooke, F. J. . . . .	N. Wa. to B'ham. T.M.O. . . . .	1.8.39
Glover, G. . . . .	E.-in-C.O. . . . .	13.11.39	Kemp, T. E. . . . .	Nottingham T.M.O. . . . .	28.6.39
<i>From H.C.O. to Chief Clerk</i>					
Fewster, T. . . . .	N.E. Reg. to Norwich . . . . .	3.7.39	Potts, J. . . . .	Newcastle T.M.O. . . . .	3.7.39
Mills, H. R. . . . .	Scot. Reg. to Sheffield . . . . .	1.7.39	Chapman, G. . . . .	S. Eastern . . . . .	3.7.39
Buckeridge, R. P. . . . .	Oxford . . . . .	4.12.39	Cheshire, C. E. . . . .	Edinburgh . . . . .	1.7.39
<i>From C.O. to E.O.</i>					
Jones, A. E. . . . .	E.-in-C.O. . . . .	12.6.39	Wilkinson, F. L. . . . .	Leeds . . . . .	17.7.39
Johnson, H. . . . .	E.-in-C.O. . . . .	12.6.39	Stockwell, H. L. P. . . . .	Canterbury . . . . .	14.8.39
Harnett, W. L. . . . .	E.-in-C.O. . . . .	15.6.39	Keir, W. S. . . . .	Scot. W. to Brighton . . . . .	6.8.39
Lambert, F. . . . .	E.-in-C.O. . . . .	21.6.39	Smith, W. H. P. . . . .	Bristol . . . . .	1.10.39
Fox, A. S. . . . .	E.-in-C.O. . . . .	11.7.39	White, G. J. . . . .	Leeds . . . . .	17.6.39
East, W. A. . . . .	E.-in-C.O. . . . .	21.9.39	Bartlett, H. F. W. . . . .	Taunton . . . . .	4.6.39
			Holmes, S. . . . .	Gloucester to Cardiff . . . . .	1.11.39
			Speers, R. . . . .	Croydon to Oxford . . . . .	4.12.39
			McGinlay, J. . . . .	Scot. W. . . . .	3.7.39
			Till, H. J. . . . .	Portsmouth . . . . .	15.11.39

Transfers

Name	District	Date	Name	District	Date
<i>E.O.'s</i>			<i>H.C.O.'s</i>		
Culff, A. R. . . . .	E.-in-C.O. to Min. of Supply . . . . .	21.8.39	Harding, H. J. . . . .	Reading to Bournemouth . . . . .	7.9.39
Smith, H. A. . . . .	E.-in-C.O. to Min. of Supply . . . . .	1.8.39	Chapman, G. . . . .	B'mouth to Canterbury . . . . .	29.8.39
Schutte, J. A. . . . .	E.-in-C.O. to Min. of Supply . . . . .	1.8.39	Roberts, L. . . . .	B'ham to Min. of Supply . . . . .	1.8.39

Retirements

Name	District	Date	Name	District	Date
<i>S.O.'s</i>					
Young, A. . . . .	E.-in-C.O. . . . .	31.5.39	Hellyer, J. . . . .	Cardiff . . . . .	30.9.39
Robinson, W. D. . . . .	E.-in-C.O. . . . .	31.7.39			

Deaths

Name	District	Date	Name	District	Date
<i>S.O.</i>					
Martin, H. E. . . . .	E.-in-C.O. . . . .	10.6.39			

BOARD OF EDITORS

A. J. GILL, B.Sc., M.I.E.E., M.Inst.R.E., Chairman.  
 F. E. NANCARROW, A.R.C.Sc., M.I.E.E., M.Inst.R.E.  
 P. B. FROST, B.Sc., M.I.E.E.  
 A. H. MUMFORD, B.Sc.(ENG.), A.M.I.E.E.  
 C. W. BROWN, A.M.I.E.E.  
 R. E. JONES, M.Sc., A.M.I.E.E.  
 H. LEIGH, B.Sc.(ENG.), A.M.I.E.E., Acting Managing Editor.

Copyright

The entire contents of this JOURNAL are covered by general copyright, and special permission is necessary for reprinting long extracts, but Editors are welcome to use not more than one-third of any article, provided credit is given at the beginning or end thus: "From the *Post Office Electrical Engineers' Journal*."

The Board of Editors is not responsible for the statements made or the opinions expressed in any of the articles in this JOURNAL, unless such statement is made specifically by the Board.

Communications

All Communications should be addressed to the Managing Editor, *P.O.E.E. Journal*, Engineer-in-Chief's Office, Alder House, Aldersgate Street, London, E.C.1. Telephone: HEADquarters 1234. Remittances should be made payable to "The *P.O.E.E. Journal*" and should be crossed " & Co."

Binding Cases

Cases for binding are available, and may be obtained from the Local Agents for 1s. 9d. Subscribers can have their copies of Volumes bound, at a cost of 3s., by sending the complete set of parts to the Local Agents or to the *P.O.E.E. Journal*, Engineer-in-Chief's Office, Alder House, Aldersgate Street, London, E.C.1. Orders for binding for Vols. 1-19 should indicate whether the original binding case with black lettering, or the later pattern with gold, is required. Cases with gold lettering are the only type stocked from Vol. 20 onwards.

Back Numbers

The price of the JOURNAL, which is published quarterly, is 1s. (1s. 3d. post free) per copy, or 5s. per annum post free. Back numbers can be supplied, subject to availability of stocks, at 1s. each (1s. 3d. post free). Orders for back numbers may be sent to the Local Agents or to the Publishers.

Advertisements

All communications relating to space reservations should be addressed to the Advertisement Editor, *P.O.E.E. Journal*, Alder House, Aldersgate Street, London, E.C.1. Communications regarding advertisement copy, proofs, etc., should be addressed to the Publishers, Messrs. Birch & Whittington (Prop. Dorling & Co. [Epsom], Ltd.), 49 Upper High Street, Epsom, Surrey.

# Post Office Electrical Engineers' Journal

Volume XXXII, April 1939—March 1940

## INDEX

A	PAGE NO.	F	PAGE NO.
Abbott, G. A. O., and R. W. Palmer. A Mobile Automatic Telephone Exchange .. .. .	1	Fairweather, A., and F. C. Williams. A "Chopped Signal" Vacuum Tube Generator with Good Voltage Regulation .. .. .	104
Addey, F. Calculation of Great Circle Bearings ..	142	Filters in Parallel, The Operation of .. .. .	135
.. Addition and Subtraction Logarithms ..	244	Financial Effects of Recent Reductions in Telephone Charges (Inland Service), The .. .. .	165
Addition and Subtraction Logarithms .. .. .	244	Finchley Road and Swiss Cottage Metropolitan Railway Improvements, The Post Office Work in Conjunction with .. .. .	39
Additional Group Modulated Carrier Systems between Stranraer and Belfast .. .. .	112	Furneaux, E. G., and E. M. Richards. The Nevin-Dublin Carrier System for Telephony and V.F. Telegraphs .. .. .	118
Angwin, A. S. Appointment as Engineer-in-Chief ..	146		
Application of Hollerith Accounting Machines to the Distribution of Engineering Instructions, The ..	94	G	
Artificial Life Tests of Cords and Flexible Conductors..	130	Gracie, J. A. Rugby Radio Station .. .. .	16
Atherton, W. S. A New Power Plant for P.M.B.X.'s..	212	Great Circle Bearings, Calculation of .. .. .	142
		Group Modulated Carrier Systems between Stranraer and Belfast, Additional .. .. .	112
B		Guest, F. Local Line Development Plant .. .. .	200
Baldock Radio-Telephone Receiving Station .. .. .	256	H	
Barnett, H. E., and W. A. H. Venus. The Application of Hollerith Accounting Machines to the Distribution of Engineering Instructions .. .. .	94	Hall, L. L., H. S. Lloyd and C. E. Richards. The Localisation of Small Leaks in the Underground Transmission Line System at Cooling Radio Station .. .. .	138
Barron, D. A. Post Office Cabling in the Mersey Tunnel .. .. .	79	Halsey, R. J., and F. Scowen. Additional Group Modulated Carrier Systems between Stranraer and Belfast .. .. .	112
Book Reviews .. .. . 38, 55, 62, 141, 183, 190, 199,	267	Harrold, E. J., and M. G. Holmes. Opening of Headquarters Exchange .. .. .	159
Booth, C. F., and C. F. Sayers. The Production of Quartz Resonators for the London-Birmingham Coaxial Cable System .. .. .	7, 88	Hartwell, C. H. The New Kingston (London) Exchange Headquarters Exchange, Opening of .. .. .	124
Bray, W. J., and W. R. H. Lowry. A new Short-wave Transatlantic Radio Receiver .. .. .	24	Hinchcliff, J. D. The Pendant Telephone .. .. .	59
		Hollerith Accounting Machines, The Application of, to the Distribution of Engineering Instructions ..	94
C		Holmes, M. G., and E. J. Harrold. Opening of Headquarters Exchange .. .. .	159
Calculation of Great Circle Bearings .. .. .	142	I	
Carr, G. E. Special Events—Telegraph Arrangements	174	Institution of Post Office Electrical Engineers.. ..	216
Chasmar, W. P., and H. E. Morrish. The Post Office Work in Conjunction with the Finchley Road and Swiss Cottage Metropolitan Railway Improvements "Chopped Signal" Vacuum Tube Generator with Good Voltage Regulation, A .. .. .	104	J	
Comité Consultatif International Téléphonique: Meeting of the Sub-Committees, London, December 1938	52	Jarvis, R. F. J., and E. C. H. Seaman. The Effect of Noise and Interfering Signals on Television Transmission .. .. .	193
Constant Impedance Equalisers: Simplified Method of Design and Standardisation .. .. .	204	.. and E. C. H. Seaman. The Essential Characteristics of Television Circuits..	224
Cooling Radio Station, The Localisation of Small Leaks in the Underground Transmission System at ..	138	Jones, R. E. Non-Linear Distortion of Music Channels with Particular Reference to the Bristol-Plymouth System .. .. .	45
Cords and Flexible Conductors, Artificial Life Tests of Cornell, W., and B. Draper. Melbourne City West Exchange .. .. .	237	.. The Operation and Utilisation of Echo-Suppressors .. .. .	247
Cornish, H. E. The Submarine Cable to Pangkor, Malaya .. .. .	85	Josephs, H. J. Note on the Resistance Noise in a Coaxial Pair .. .. .	61
Crosstalk, The Reduction of, on Trunk Circuits, by the Use of the Volume Range Compressor and Expander	32	Junior Section Notes .. .. .	67, 148, 264
D		K	
Damming, Stream- .. .. .	261	Kingston (London) Exchange, The New .. .. .	124
District Notes .. .. . 68, 150, 217,	265		
Draper, B., and W. Cornell. Melbourne City West Exchange .. .. .	237		
E			
Echo-Suppressors, The Operation and Utilisation of ..	247		
Effect of Noise and Interfering Signals on Television Transmission, The .. .. .	193		
Equalisers, Constant Impedance: Simplified Method of Design and Standardisation .. .. .	204		
Essential Characteristics of Television Circuits, The	224		
Evans, G. T., and J. E. Luckhurst. Baldock Radio-Telephone Receiving Station .. .. .	256		

<b>L</b>	PAGE NO.
Lawton, J. The Reduction of Crosstalk on Trunk Circuits by the Use of the Volume Range Compressor and Expander .. .. .	32
Lee, Retirement of Sir George .. .. .	145
Lidstone, F. J. W., and O. S. Stiles. Artificial Life Tests of Cords and Flexible Conductors .. .. .	130
Lloyd, H. S., C. E. Richards and L. L. Hall. The Localisation of Small Leaks in the Underground Transmission Line System at Cooling Radio Station .. .. .	138
Local Centre Notes .. .. .	66, 148
Localisation of Small Leaks in the Underground Transmission Line System at Cooling Radio Station, The .. .. .	138
Local Line Development Plant .. .. .	200
Logarithms, Addition and Subtraction .. .. .	244
Lowry, W. R. H., and W. J. Bray. A New Short-wave Transatlantic Radio Receiver .. .. .	24
Luckhurst, J. E., and G. T. Evans. Baldock Radio-Telephone Receiving Station .. .. .	256
<b>M</b>	
Malaya, The Submarine Cable to Pangkor .. .. .	85
Melbourne City West Exchange .. .. .	237
Mersey Tunnel, Post Office Cabling in the .. .. .	79
Mew, G. M. The Supply of Power for Telephone Exchanges .. .. .	184
Mobile Automatic Telephone Exchange, A .. .. .	1
Morrish, H. G., and W. P. Chasmar. The Post Office Work in Conjunction with the Finchley Road and Swiss Cottage Metropolitan Railway Improvements .. .. .	39
Music Channels, Non-Linear Distortion of, with Particular Reference to the Bristol-Plymouth System .. .. .	45
<b>N</b>	
Nevin-Dublin Carrier System for Telephony and V.F. Telegraphs, The .. .. .	118
New Developments in Power Circuit Guarding .. .. .	219
New Power Plant for P.M.B.X.'s, A .. .. .	212
Noise and Interfering Signals, Effect of, on Television Transmission .. .. .	193
Non-Linear Distortion of Music Channels with Particular Reference to the Bristol-Plymouth System .. .. .	45
Note on the Resistance Noise in a Coaxial Pair .. .. .	61
Notes and Comments .. .. .	63, 144, 216, 264
Notes, District .. .. .	68, 150, 216, 265
Notes, Junior Section .. .. .	67, 148, 264
Notes, Local Centre .. .. .	66, 148
Notes, Regional .. .. .	265
<b>O</b>	
O'dell, G. F. Promotion to Assistant Engineer-in-Chief .. .. .	147
Opening of Headquarters Exchange .. .. .	159
Operation and Utilisation of Echo-Suppressors, The .. .. .	247
Operation of Filters in Parallel, The .. .. .	135
<b>P</b>	
Palmer, R. W., and G. A. O. Abbott. A Mobile Automatic Telephone Exchange .. .. .	1
Pendant Telephone, The .. .. .	59
Post Office Cabling in the Mersey Tunnel .. .. .	79
Post Office Work in Conjunction with the Finchley Road and Swiss Cottage Metropolitan Railway Improvements .. .. .	39
Power Circuit Guarding, New Developments in .. .. .	219
Power Plant for P.M.B.X.'s, A New .. .. .	212
Power Supply for Telephone Exchanges, The .. .. .	184
Production of Quartz Resonators for the London-Birmingham Coaxial Cable System, The .. .. .	7, 88
Pyrah, F. Constant Impedance Equalisers: Simplified Method of Design and Standardisation .. .. .	204

<b>Q</b>	PAGE NO.
Quartz Resonators for the London-Birmingham Coaxial Cable System, The Production of .. .. .	7, 88
<b>R</b>	
Radio Receiver, A New Transatlantic Short-wave .. .. .	24
Reduction of Crosstalk on Trunk Circuits by the Use of the Volume Range Compressor and Expander, The .. .. .	32
Regional Notes .. .. .	265
Resistance Noise in a Coaxial Pair, Note on the .. .. .	61
Richards, C. E., L. L. Hall and H. S. Lloyd. The Localisation of Small Leaks in the Underground Transmission System at Cooling Radio Station .. .. .	138
Richards, E. M., and E. G. Furneaux. The Nevin-Dublin Carrier System for Telephony and V.F. Telegraphs .. .. .	118
Ridd, P. J. Promotion to Deputy Engineer-in-Chief .. .. .	147
Rimes, R. E. New Developments in Power Circuit Guarding .. .. .	219
Rugby Radio Station .. .. .	16
<b>S</b>	
Sayers, C. F., and C. F. Booth. The Production of Quartz Resonators for the London-Birmingham Coaxial Cable System .. .. .	7, 88
Scowen, F., and R. J. Halsey. Additional Group Modulated Carrier Systems between Stranraer and Belfast .. .. .	112
Seaman, E. C. H., and R. F. J. Jarvis. The Effect of Noise and Interfering Signals on Television Transmission .. .. .	193
.. .. . and R. F. J. Jarvis. The Essential Characteristics of Television Circuits .. .. .	224
Soons, A. T. Stream-Damming .. .. .	261
Special Events—Telegraph Arrangements .. .. .	174
Staff Changes .. .. .	77, 156, 268
Stanesby, H. The Operation of Filters in Parallel .. .. .	135
Stiles, O. S., and F. J. W. Lidstone. Artificial Life Tests of Cords and Flexible Conductors .. .. .	130
Stranraer - Belfast, Additional Group Modulated Carrier Systems between .. .. .	112
Stream-Damming .. .. .	261
Submarine Cable to Pangkor, Malaya, The .. .. .	85
Supply of Power for Telephone Exchanges, The .. .. .	184
Swanwick Convention, The .. .. .	191
Swiss Cottage and Finchley Road Metropolitan Railway Improvements. The Post Office Work in Conjunction with .. .. .	39
<b>T</b>	
Telegraph Special Event Arrangements .. .. .	174
Television Circuits, The Essential Characteristics of .. .. .	224
Television Transmission. The Effect of Noise and Interfering Signals on .. .. .	193
Townshend, H. The Financial Effects of Recent Reductions in Telephone Charges (Inland Service) .. .. .	165
Transatlantic Radio Receiver, A New Short-wave .. .. .	24
<b>U</b>	
Universal Decimal Classification of Information, The .. .. .	56
<b>V</b>	
Venus, W. A. H., and H. E. Barnett. The Application of Hollerith Accounting Machines to the Distribution of Engineering Instructions .. .. .	94
<b>W</b>	
Williams, F. C., and A. Fairweather. A "Chopped Signal" Vacuum Tube Generator with Good Voltage Regulation .. .. .	104
Wright, J. E. The Universal Decimal Classification of Information .. .. .	56



---

## *Miniature tuning forks for frequency standards or filters*

---

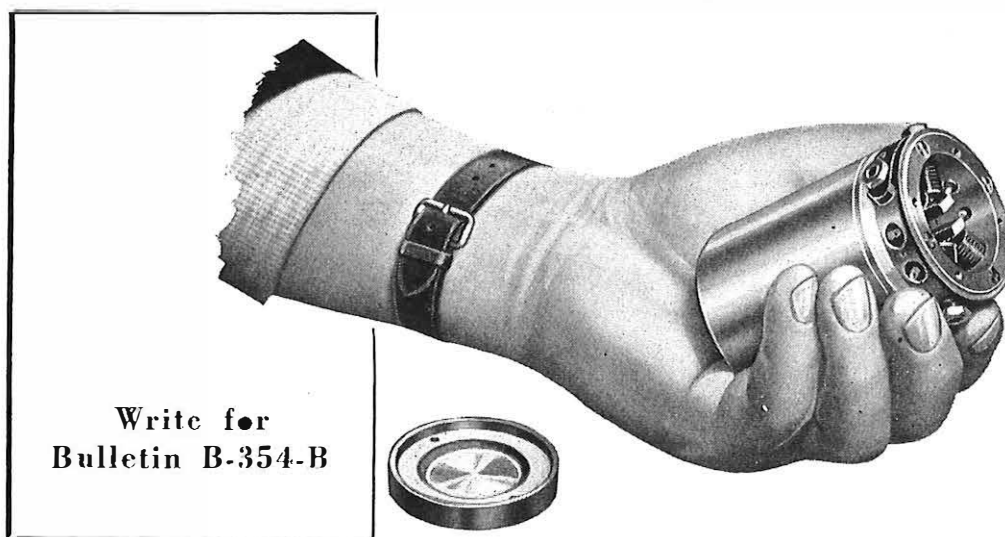

In the past, the design of tuning forks has rather tended to run on "heavy engineering" lines. We have, however, recently experimented with forks of less generous proportions and have found that considerable advantages are obtained. As a frequency standard, the small dimensions of these miniature tuning forks simplify oven design and enable temperature control to  $0.1^{\circ}\text{C}$ . to be obtained with a very simple thermostat. A new driving circuit gives extremely good stability with changes in thermionic conditions. The complete equipment, temperature and pressure controlled and providing half a watt output of stabilised frequency, only occupies a panel 19 in. by  $10\frac{1}{2}$  in. Any single frequency between 500 cps. and 4,000 cps. may be provided. As a filter one of these 1,000 cps. forks will give a discrimination of 40 db. at 5 cps. off the resonant frequency. *Prices: Mains Operated Frequency Standard £70. Filter Fork £15.*

**MUIRHEAD**

MUIRHEAD AND COMPANY LIMITED, ELMERS END, BECKENHAM, KENT. TELEPHONE: BECKENHAM 0041-0042  
FOR OVER 60 YEARS DESIGNERS & MAKERS OF PRECISION INSTRUMENTS

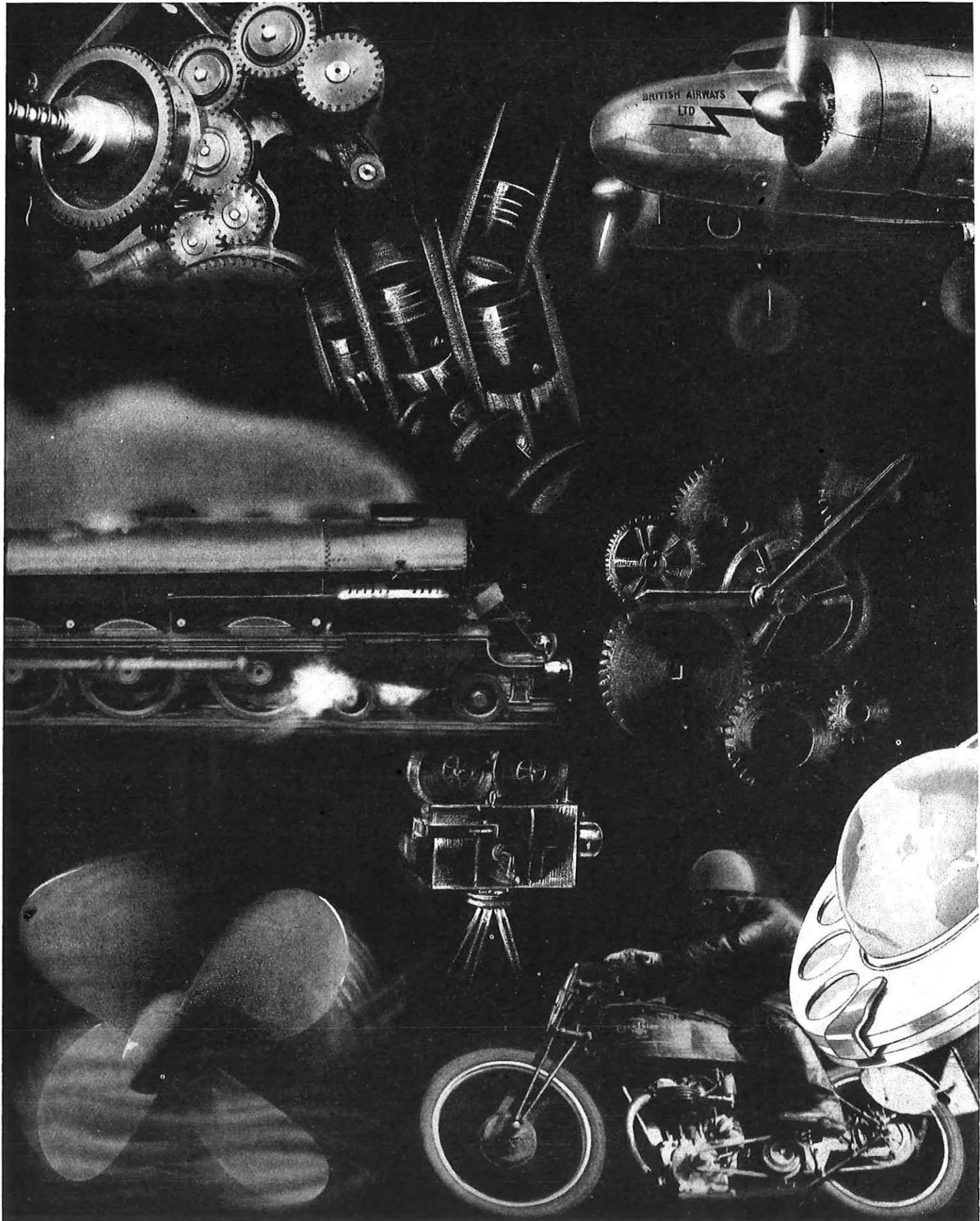

# THE STROWGER DIAL.

ROTATES WITH THE WORLD

Industry . . . commerce . . . transport . . . social life . . . in some form or another of the world's activities wheels rotate unceasingly. Inextricably merged with their movements—initiating, maintaining or controlling them—are Strowger automatic telephone dials. The part which Strowger automatic telephones play in this respect can be judged from the fact that Strowger dials rotate on an average more than a billion times each week, enabling conversations to take place between twelve million Strowger subscribers located throughout the world.

Practical experience has proved that the introduction of Strowger automatic telephony results in considerable economic expansion. More wheels begin to turn, and to keep pace

more Strowger equipment is required. Thus the world progresses.

Not only the great State and other telephone administrations of the world, but also many thousands of private organisations operate Strowger telephones. Factories, offices, institutions, and many others find in Strowger telephony the means for pursuing their activities with efficiency and despatch.



## AUTOMATIC TELEPHONE & ELECTRIC CO. LTD.

NORFOLK HOUSE, NORFOLK ST., STRAND, W.C.2

'Phone Temple Bar 9262 'Grams "Autelco, Estrand, London"

STROWGER WORKS, LIVERPOOL, 7

'Phone Stoneycroft 4830 'Grams "Strowger, Liverpool"



# NO FUEL SHORTAGE FOR 'ELECTRICS'

HOWEVER the fuel problem develops ample power is assured for 'electrics' in war-time. This gives them another overwhelming advantage for short distance transport. Furthermore anyone with road sense learns to drive an 'electric' in a very little while. To secure maximum economy and reliability for 'electrics' they must be equipped with strongly built batteries that sustain their

voltage under all conditions throughout a long and trouble-free life.

Ever since 'electrics' first appeared the Chloride Company have put their full resources behind perfecting batteries for this purpose—and Chloride are the biggest battery makers in the British Empire. They also have the most effective after-sales service organisation in the country.

## Exide-Ironclad BATTERIES

Still keep going  
when the rest  
have stopped'

\* For further details about electric vehicles and batteries write to The Chloride Electrical Storage Co., Ltd., Battery Traction Dept., Exide Works, Clifton Junction, near Manchester. London Office, 137, Victoria St., S.W.1.

# G.E.C.



## RURAL AUTOMATIC EXCHANGES

Set amidst tropic vegetation or where the snow crunches underfoot, G.E.C. rural automatic exchanges operate under a climatic range that is as wide as the range of facilities they provide. With capacities from 10 lines upwards, these unattended exchanges bring to subscribers outside towns and cities a telephone service in which there are:—

**NO OPERATORS ● NO DELAY ● NO WRONG NUMBERS**  
**TWENTY-FOUR-HOUR SERVICE**

Catalogue No. 20 gives full particulars

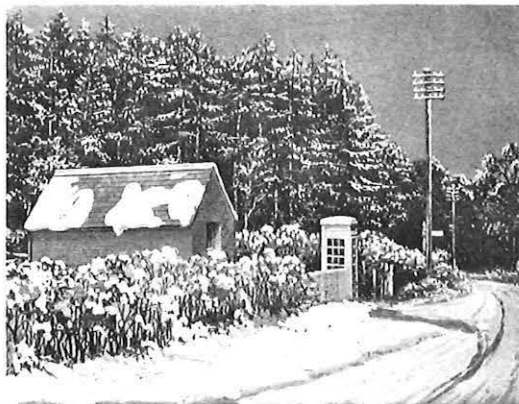

**THE GENERAL ELECTRIC CO. LTD. OF ENGLAND**

**TELEPHONE WORKS**

**COVENTRY**

**ENGLAND**

Coventry 4111 (10 lines)

Springjack, Coventry

HEAD OFFICE: MAGNET HOUSE, KINGSWAY, LONDON, W.C.2

## INDEX TO ADVERTISERS

Austinlite, Ltd. . . . .	xx
Automatic Coil Winder & Electrical Equipment Co., Ltd. . . . .	iii
Automatic Telephone & Electric Co., Ltd. . . . .	xii & xiii
British Institute of Engineering Technology, The . . . . .	xvii
Caplin Engineering Co., Ltd. . . . .	iv
Creed & Co., Ltd. . . . .	ix
Edison Swan Electric Co., Ltd., The . . . . .	viii
Elliott Bros. (London), Ltd. . . . .	xxi
Ericsson Telephones, Ltd. . . . .	xviii & xix
Exide . . . . .	xiv
Ferranti, Ltd. . . . .	xvii
General Electric Co., Ltd., The . . . . .	ii & xv
Hall Telephone Accessories (1928), Ltd. . . . .	xx
International Correspondence Schools, Ltd. . . . .	xx
Muirhead & Co., Ltd. . . . .	xi
Pirelli-General Cable Works, Ltd. . . . .	xxii
Rawplug Co., Ltd., The . . . . .	ix
Siemens Brothers & Co., Ltd. . . . .	vi & vii
Smith, Frederick, & Co. . . . .	xxi
Standard Telephones & Cables, Ltd. . . . .	x
Sullivan, H. W., Ltd. . . . .	viii
Telephony Publishing Corporation . . . . .	xvi
Turner, Ernest . . . . .	xvi
Westinghouse Brake & Signal Co., Ltd. . . . .	v

For All the Latest News and  
Technical Data about the  
Telephone Field—READ

## TELEPHONY

The best investment a telephone man can make is TO INVEST IN HIMSELF. Whether you are new in the business or an old-timer, TELEPHONY will give you practical and up-to-the-minute ideas for doing your work better. There is no other magazine covering every department of the telephone business as comprehensively. Know all the latest approved telephone practices and all the current telephone news. Read TELEPHONY. Subscription price \$5.00 per year. Published since 1901.

## TELEPHONY

Address: Odhams Press, Ltd., Technical Book Dept., 85 Long Acre, London, W.C.2 (Telephone: Temple Bar 2468) for a sample copy of TELEPHONY, or write direct to:

**TELEPHONY PUBLISHING CORPN.**  
608 S. Dearborn Street, Chicago, Ill., U.S.A.

## TURNER DIFFERENTIAL MILLIAMMETERS G.P.O. No. 17 & No. 18

Meet the most  
exacting demands  
for balancing currents  
in multiplex telegraph circuits.

—A quality  
product of outstanding  
merit—

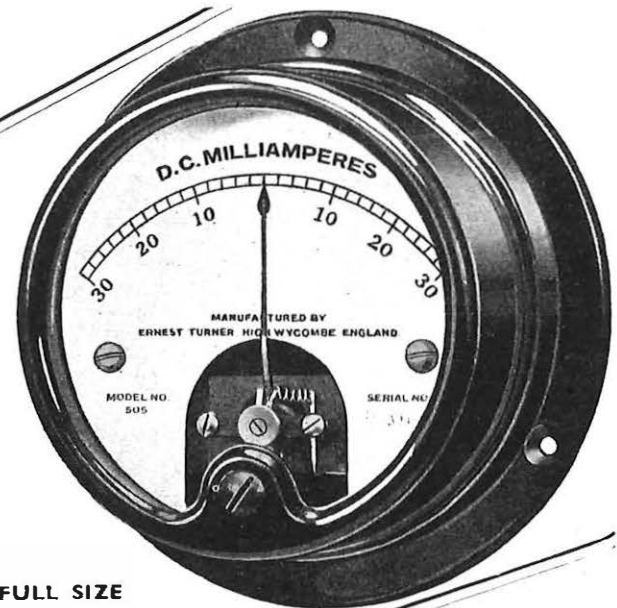

FULL SIZE

Also manufacturers of G.P.O. Detector No. 4, and a comprehensive line of instruments for precision electrical measurements.

**ERNEST TURNER ELECTRICAL INSTRUMENTS, Ltd.**

**CHILTERN WORKS,  
49-73 TOTTERIDGE AVENUE,  
HIGH WYCOMBE,  
BUCKS, ENGLAND**

Telephone: High Wycombe 1301, 1302.  
Telegrams: Gorgeous, High Wycombe.

# Ferranti

## CLIP-ON AMMETER

Just turn  
the switch  
to change  
the range.

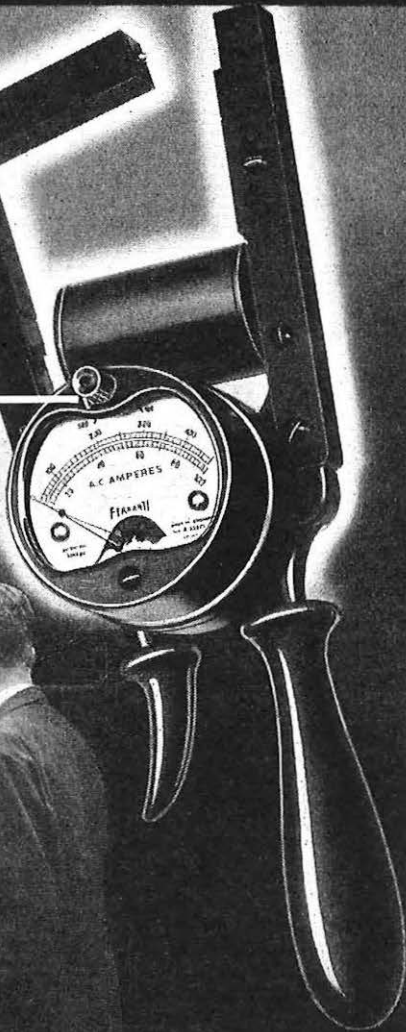

THE CLIP-ON AMMETER has become established as an indispensable instrument for the rapid measurement of currents in busbars, fuses and cables.

You simply take the instrument in one hand, clip round the conductor and observe the reading!

Don't worry if the conductor is bare—the core is completely insulated and the frame is of moulded bakelite.

#### COMPREHENSIVE RANGES AVAILABLE :

0 - 100 - 500	0 - 7.5 - 75	0 - 20 - 100
0 - 100 - 1000	0 - 10 - 50	0 - 25 - 150
0 - 200 - 1000	0 - 15 - 75	0 - 50 - 250
0 - 300 - 1500		

Write for List IN II.

**FERRANTI LTD., HOLLINWOOD, LANCS.**  
London Office, BUSH HOUSE, ALDWYCH, W.C.2.

Fl.33a

# PROMOTION

## COMMENCE YOUR PREPARATION IMMEDIATELY.

Since the B.I.E.T. was founded twelve years ago, we have specialised in preparing candidates for leading Technical Examinations, and our success may be gauged from the following remarkable results :

### FIVE 1st PLACES

In the Probationary Inspectors and Assistant Superintendents of Traffic Examinations held in 1932-1938, B.I.E.T. candidates obtained **Five First Places.**

### FIRST THREE PLACES

In the 1937 Competitions for Probationary Inspectors, B.I.E.T. candidates secured **First, Second and Third Places.**

### 239 SUCCESSES

In the Probationary Inspectors and Assistant Superintendents of Traffic Examinations held in 1934-1938, **239 B.I.E.T. candidates passed the Examinations.**

We teach successfully by correspondence and definitely guarantee—

### “NO PASS—NO FEE”

You are advised to send for a copy of our General Prospectus “ENGINEERING OPPORTUNITIES.” This Handbook contains 268 pages of most useful information. It also contains particulars of all leading Engineering Examinations, including

**Probationary Inspectors** (Open and Limited Competitions).

**Probationary Assistant Engineers** (Limited Competition).

**Assistant Superintendent of Traffic** (Open and Limited Competitions).

**City and Guilds, I.E.E., B.Sc., A.M.I.C.E., A.M.I.Mech.E., London Matric., etc., etc.**

The Handbook also outlines “up-to-the-minute” courses of Home-Study in *all branches* of Engineering.

Special Courses are offered in **Telegraphy, Manual Telephony, Automatic Telephony, Telephone Transmission, Electrical Technology, Wireless and High Frequency, Radio Communication, Alternating Currents, etc., etc.**

Our 268 pages Handbook should be on your Book-shelf. It will be gladly sent on request, **FREE** and without obligation. (*Please state subject or Examination of most interest.*)

## British Institute of Engineering Technology

369 Shakespeare House,

17, 18 & 19 Stratford Place, Oxford Street,  
London, W.1

# The New Star of the Telephone World

**T**HE new Ericsson Automatic Telephone No. 1002 shown here has a casework of black moulded bakelite in a modern, distinctive and pleasing design. It incorporates a form of cradle or micro-telephone rest which is not readily damaged should the instrument get violently knocked or fall to the ground.

The whole of the interior apparatus which is mounted on a frame can be removed as a unit, the base plate which incorporates a useful sliding tray fitment being first removed. Dimensions, 6 by  $9\frac{1}{2}$  by  $8\frac{1}{2}$  inches ; weight, 6 lbs.

**NOW AVAILABLE TO P.O. SUBSCRIBERS**

*Full particulars from makers :*

**ERICSSON TELEPHONES LTD.**

**HEAD OFFICE : 22 LINCOLN'S INN FIELDS, LONDON, W.C.2.**

*Works : Beeston, Notts.*

*(Telephone : HOLborn 6936)*





CREATED BY

**Ericsson**

TELEPHONES LTD.





## Spare-Time Training by Post in all Electrical Subjects

The International Correspondence Schools, largest and most successful institution of its kind in the world, offers thoroughly sound Courses of Instruction to cover the following Examinations:

**GRADUATESHIP, I.E.E.**

**CITY AND GUILDS ELECTRICAL ENGINEERING PRACTICE.  
ELECTRIC INSTALLATION AND TELECOMMUNICATIONS.  
G.P.O. PROBATIONARY ASSISTANT ENGINEER (LIMITED).  
G.P.O. PROBATIONARY INSPECTOR (ENGINEERING DEPT.).  
ASSISTANT TRAFFIC SUPERINTENDENT, TELEPHONE SERVICE.**

**P.M.G. CERTIFICATE FOR WIRELESS OPERATORS.  
PROVISIONAL CERTIFICATE IN RADIO TELEPHONY AND  
TELEGRAPHY FOR AIRCRAFT.**

**INSTITUTE OF WIRELESS TECHNOLOGY.**

Other Courses meet the requirements of all who desire to qualify for responsible positions in Electric Power, Light and Traction Stations. Equally successful is our instruction for Telegraph and Telephone Engineers, Telegraphists and Telephonists, Radio Engineers, Radio Servicemen, and those who wish to study Television.

Instruction is by correspondence from textbooks specially prepared by many experts in tuition by post.

**WRITE FOR OUR SPECIAL BOOKLET**

stating Examination or Subject in which you are interested.

**INTERNATIONAL  
CORRESPONDENCE SCHOOLS LTD.**

DEPT. 108

International Buildings, Kingsway, London, W.C.2



## Hall Telephone Accessories (1928) Limited

Suppliers to the British Post Office, Air Ministry, Admiralty, War Office and Foreign Government Departments.

**Manufacturers of prepayment telephone multi-coin collectors, gas leak indicators, precision instruments, automatic stamp selling and ticket selling machines, automatic slot machines and fire alarm apparatus.**

*Registered*

**Office & Works: 70, DUDDEN HILL LANE,  
WILLESDEN,**

**TEL. WILLESDEN 5141/2/3. LONDON, N.W. 10**

**Also GUEST WORKS, DOWLAIS, STH. WALES**

# Austinlite

## AUTOMATIC STANDBY PLANT

Recently completed AUSTIN-LITE STANDBY PLANTS range in size from a 200 k.w. Automatic Plant for a large Municipal Power Station to a 2½ k.w. Plant for an A.R.P. Shelter.

Whatever the size and purpose of the plant the same stringent test conditions are applied.

**AUSTINLITE LTD.**

*Proprietors:*

**CHANCE BROTHERS & CO. LIMITED  
LIGHTHOUSE WORKS, SMETHWICK**

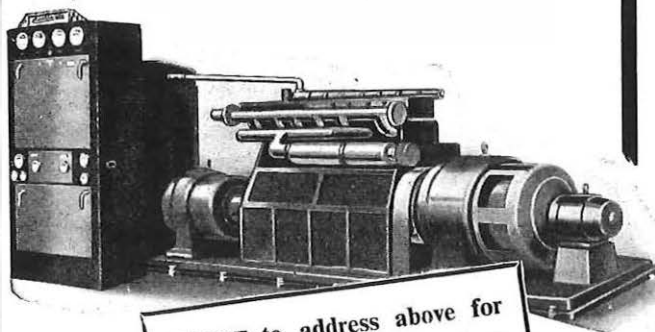

**WRITE to address above for  
full details and specifications  
covering your requirements.**

# ANACOS

REGD.

## WIRES

in

### BRONZE AND CADMIUM-COPPER

AS SUPPLIED TO H.M. POST OFFICE  
FOR TELEPHONE LINES

SEND US PARTICULARS OF YOUR JOB  
AND OUR TECHNICAL ENGINEERS WILL  
PROVIDE YOU WITH THE DATA YOU NEED



TELEPHONE  
BLACKFRIARS  
8701 (8 lines)

**FREDERICK SMITH & COMPANY**  
(INCORPORATED IN THE LONDON ELECTRIC WIRE COMPANY AND SMITHS, LIMITED)  
ANACONDA WORKS, SALFORD, 3, LANCS.

TELEGRAMS  
"ANACONDA"  
MANCHESTER

## Differential Moving Coil MILLIAMMETERS For Telegraph Circuits



T. 1098. WALL MOUNTING TYPE.

British  
Instruments  
for  
British  
Industries

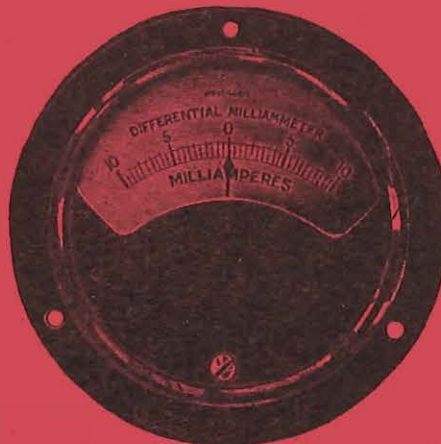

T. 1089. PANEL MOUNTING TYPE.

Particulars will be sent on request.

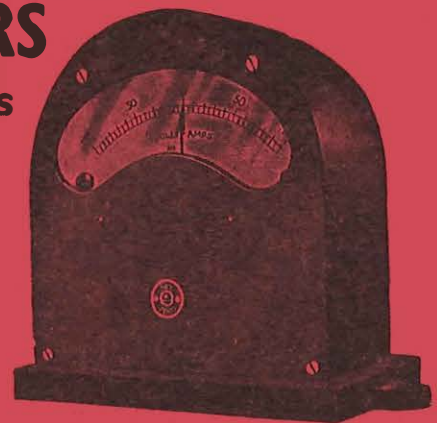

T. 1097. TABLE MOUNTING TYPE.

### TABLE, WALL AND PANEL MOUNTING TYPES

INVALUABLE as line Milliammeters  
on Differential Duplex, Sub-Audio  
Frequency and many other Telegraph Systems, also for testing  
purposes in connection with Land Lines and Radio Communication.

**ELLIOTT BROTHERS (London) LTD., Century Works, Lewisham, S.E.13**

in association with

**SIEMENS BROTHERS & COMPANY, LIMITED, Woolwich, London, S.E.18**

Telephone :  
Tideway 3232

Telephone :  
Woolwich 2020

OVER **2½ MILLION** YARDS

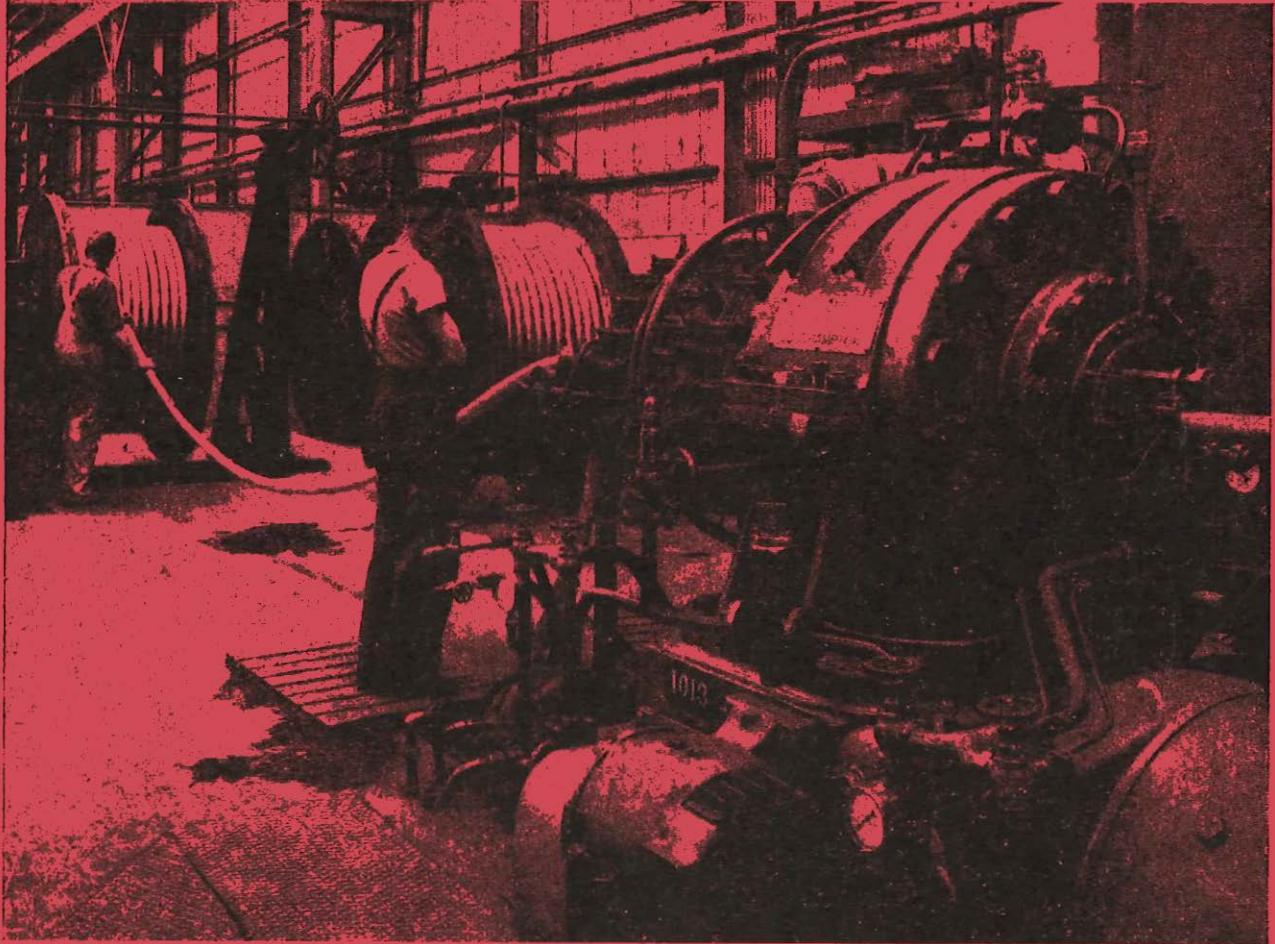

OF AIR SPACE TELEPHONE AND  
SUPERTENSION CABLES HAVE  
NOW BEEN SHEATHED ON THE  
PIRELLI-GENERAL CONTINUOUS  
LEAD EXTRUDING MACHINES.

TELEPHONE:  
SOUTHAMPTON  
2141 (5 lines).

**PIRELLI-GENERAL**  
CABLE WORKS, Ltd., SOUTHAMPTON.

TELEGRAMS  
"PIGEKAYBEL"  
SOUTHAMPTON.

Proprietors: PIRELLI, Ltd., and THE GENERAL ELECTRIC CO., LTD.